

ENGINE

Engine Oil Level

This single cylinder engine is a wet-sump engine, meaning the oil is contained in the bottom of the crankcase. To check the oil level follow the procedure listed below:

1. Position vehicle on a level surface.
2. Place the transmission in Park (P).
3. Be sure engine OFF has not been run for at least 3 minutes.

IMPORTANT: Do not run the machine and then immediately check the dipstick.

4. Locate the engine oil dipstick:
 - **RZR 570 - Located on the RH side of the engine case; accessible through the RH rear wheel well area.**

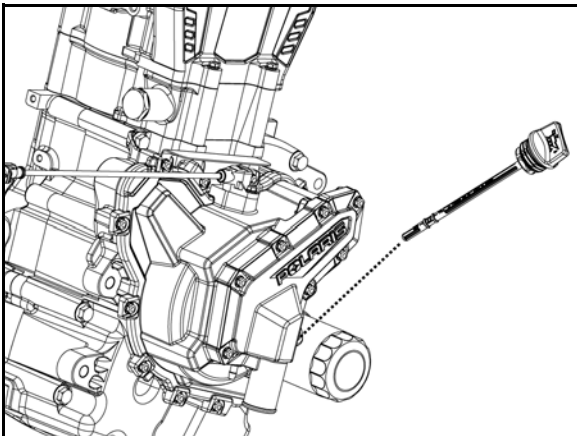

5. Be sure to clean area around dipstick to ensure no dirt / debris falls into the dip stick hole.
6. Unscrew and remove dipstick and wipe dry with a clean cloth.
7. Reinstall the dipstick completely.

NOTE: Make certain the dipstick is threaded all the way into the engine case.

8. Unscrew and remove dipstick and check to see that the oil level is in the SAFE (XX) range. Add oil as indicated by the level on the dipstick. Do not overfill (see NOTE below!).



NOTE: A rising oil level between checks in cool weather driving can indicate contaminants such as gas or moisture collecting in the crankcase. If the oil level is over the full mark, change the oil immediately.

9. Reinstall the dipstick and hand tighten.

Engine Oil and Filter Service

Always change engine oil and filter at the intervals outlined in the Periodic Maintenance Chart. Always change the oil filter whenever changing the engine oil.

IMPORTANT: Thoroughly clean engine around the oil drain plug, oil filter and oil dipstick to prevent contamination from entering the engine.

! WARNING

Personal injury can occur when handling used oil. Hot oil can cause burns or skin damage.

Recommended Engine Oil:

**PS-4 Plus Synthetic 4-Cycle Engine Oil
(PN 2876244) (Quart)**

1. Position vehicle on a level surface.
2. Place the transmission in PARK (P).

3. Start the engine. Allow it to idle for two to three minutes until warm. Stop the engine.

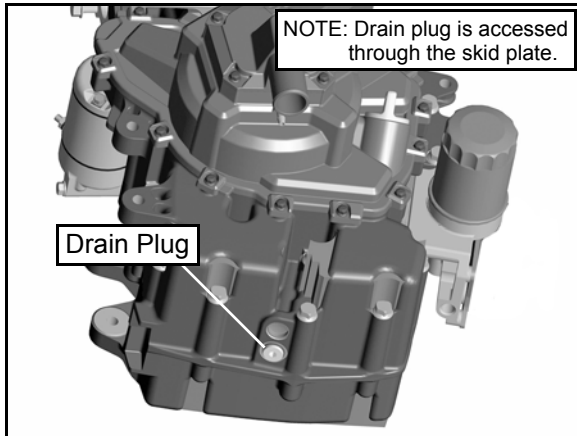

CAUTION

Oil may be hot. Do not allow hot oil to come into contact with skin, as serious burns may result.

4. Place a drain pan beneath engine crankcase and remove the drain plug.
 5. Allow oil to drain completely.
 6. Replace the sealing washer on drain plug.
- NOTE: The sealing surface on the drain plug should be clean and free of burrs, nicks or scratches.**
7. Reinstall drain plug and torque to **12 ft. lbs. (16 Nm)**.
 8. Place a drain pan under vehicle below the oil filter.
 9. Place shop towels beneath oil filter. Using Oil Filter Wrench (PU-50105) and a 3/8" extension, turn the oil filter counter-clockwise to remove it.

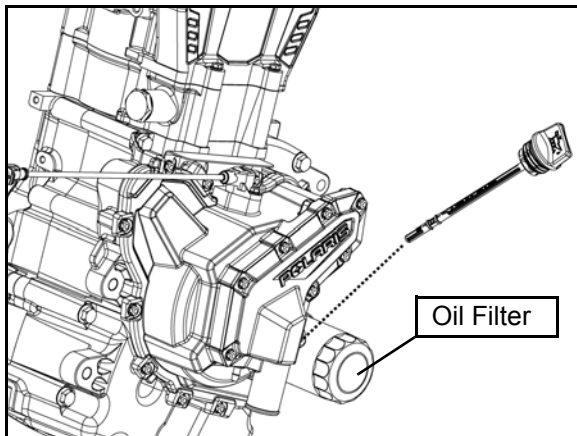

10. Using a clean dry cloth, clean filter sealing surface on the crankcase.

11. Lubricate O-ring on new filter with a film of fresh engine oil. Check to make sure the O-ring is in good condition.
12. Install new filter and turn by hand until filter gasket contacts the sealing surface, then turn an additional 1/2 turn.
13. Remove the engine oil dipstick (see "Engine Oil Level").
14. Using a long funnel, fill the sump with 2 qts. (1.9 l) of PS-4 Plus Synthetic Engine Oil (2876244).



Crankcase Drain Plug Torque:
12 ft. lbs. (16 Nm)

Oil Filter Torque:
Turn by hand until filter gasket contacts sealing surface, then turn an additional 1/2 turn

Oil Filter Wrench:
PU-50105: 2.5" (64 mm)

15. Verify the transmission is still positioned in PARK (P).
16. Start the engine and let it idle for one to two minutes.
17. Stop the engine and inspect for leaks.
18. Re-check the oil level on the dipstick and add oil as necessary to bring the level to the upper mark on the dipstick.
19. Dispose of used oil and oil filter properly.