

# Owner's Manual & Safety Instructions

**Save This Manual** Keep this manual for the safety warnings and precautions, assembly, operating, inspection, maintenance and cleaning procedures. Write the product's serial number in the back of the manual near the assembly diagram (or month and year of purchase if product has no number). Keep this manual and the receipt in a safe and dry place for future reference.

19a

**CHICAGO**  **ELECTRIC**  
POWER TOOLS

**61971**

## 10" SLIDING COMPOUND MITER SAW



**Note: Blade sold separately.**

Visit our website at: <http://www.harborfreight.com>

Email our technical support at: [productsupport@harborfreight.com](mailto:productsupport@harborfreight.com)

When unpacking, make sure that the product is intact and undamaged. If any parts are missing or broken, please call 1-888-866-5797 as soon as possible.

Copyright© 2013 by Harbor Freight Tools®. All rights reserved.

No portion of this manual or any artwork contained herein may be reproduced in any shape or form without the express written consent of Harbor Freight Tools. Diagrams within this manual may not be drawn proportionally. Due to continuing improvements, actual product may differ slightly from the product described herein.

Tools required for assembly and service may not be included.

### **WARNING**

Read this material before using this product. Failure to do so can result in serious injury. **SAVE THIS MANUAL.**

# Table of Contents





Safety .....	2	Maintenance .....	14
Specifications .....	7	Parts List and Diagram .....	17
Setup .....	8	Warranty .....	20
Operation.....	10		

SAFETY

# CHICAGO ELECTRIC<sup>®</sup> POWER TOOLS

SETUP

## WARNING SYMBOLS AND DEFINITIONS

	This is the safety alert symbol. It is used to alert you to potential personal injury hazards. Obey all safety messages that follow this symbol to avoid possible injury or death.
	Indicates a hazardous situation which, if not avoided, will result in death or serious injury.
	Indicates a hazardous situation which, if not avoided, could result in death or serious injury.
	Indicates a hazardous situation which, if not avoided, could result in minor or moderate injury.
	Addresses practices not related to personal injury.

OPERATION

## IMPORTANT SAFETY INFORMATION

### General Tool Safety Warnings

#### WARNING

**Read all safety warnings and all instructions.**

*Failure to follow the warnings and instructions may result in electric shock, fire and/or serious injury.*

**Save all warnings and instructions for future reference.**

- KEEP GUARDS IN PLACE and in working order.
- REMOVE ADJUSTING KEYS AND WRENCHES. Form habit of checking to see that keys and adjusting wrenches are removed from tool before turning it on.
- KEEP WORK AREA CLEAN. Cluttered areas and benches invite accidents.
- DON'T USE IN DANGEROUS ENVIRONMENT. Don't use power tools in damp or wet locations, or expose them to rain. Keep work area well lighted.
- KEEP CHILDREN AWAY. All visitors should be kept safe distance from work area.
- MAKE WORKSHOP KID PROOF with padlocks, master switches, or by removing starter keys.
- DON'T FORCE TOOL. It will do the job better and safer at the rate for which it was designed.
- USE RIGHT TOOL. Don't force tool or attachment to do a job for which it was not designed.

MAINTENANCE

## General Tool Safety Warnings (continued)

**Table A: RECOMMENDED MINIMUM WIRE GAUGE FOR EXTENSION CORDS (120 VOLT)**

NAMEPLATE AMPERES (at full load)	EXTENSION CORD LENGTH			
	25'	50'	100'	150'
0 – 6	18	16	16	14
6.1 – 10	18	16	14	12
10.1 – 12	16	16	14	12
12.1 – 16	14	12	<b>Do not use.</b>	

9. **USE PROPER EXTENSION CORD.** Make sure your extension cord is in good condition. When using an extension cord, be sure to use one heavy enough to carry the current your product will draw. An undersized cord will cause a drop in line voltage resulting in loss of power and overheating. Table A shows the correct size to use depending on cord length and nameplate ampere rating. If in doubt, use the next heavier gauge. The smaller the gauge number, the heavier the cord.
10. **WEAR PROPER APPAREL.** Do not wear loose clothing, gloves, neckties, rings, bracelets, or other jewelry which may get caught in moving parts. Non-slip footwear is recommended. Wear protective hair covering to contain long hair.
11. **ALWAYS USE SAFETY GLASSES.** Also use face or dust mask if cutting operation is dusty. Everyday eyeglasses only have impact resistant lenses, they are NOT safety glasses.
12. **SECURE WORK.** Use clamps or a vise to hold work when practical. It's safer than using your hand and it frees both hands to operate tool.
13. **DON'T OVERREACH.** Keep proper footing and balance at all times.
14. **MAINTAIN TOOLS WITH CARE.** Keep tools sharp and clean for best and safest performance. Follow instructions for lubricating and changing accessories.
15. **DISCONNECT TOOLS** before servicing when changing accessories, such as blades, bits, cutters, and the like.
16. **REDUCE THE RISK OF UNINTENTIONAL STARTING.** Make sure switch is in off position before plugging in.
17. **USE RECOMMENDED ACCESSORIES.** Consult the owner's manual for recommended accessories. The use of improper accessories may cause risk of injury to persons.
18. **NEVER STAND ON TOOL.** Serious injury could occur if the tool is tipped or if the cutting tool is unintentionally contacted.
19. **CHECK DAMAGED PARTS.** Before further use of the tool, a guard or other part that is damaged should be carefully checked to determine that it will operate properly and perform its intended function – check for alignment of moving parts, binding of moving parts, breakage of parts, mounting, and any other conditions that may affect its operation. A guard or other part that is damaged should be properly repaired or replaced.
20. **DIRECTION OF FEED.** Feed work into a blade or cutter against the direction of rotation of the blade or cutter only.
21. **NEVER LEAVE TOOL RUNNING UNATTENDED. TURN POWER OFF.** Don't leave tool until it comes to a complete stop.

## Grounding Instructions

### ⚠️ WARNING



**TO PREVENT ELECTRIC SHOCK AND DEATH FROM INCORRECT GROUNDING WIRE CONNECTION:**

Check with a qualified electrician if you are in doubt as to whether the outlet is properly grounded. Do not modify the power cord plug provided with the tool. Never remove the grounding prong from the plug. Do not use the tool if the power cord or plug is damaged. If damaged, have it repaired by a service facility before use. If the plug will not fit the outlet, have a proper outlet installed by a qualified electrician.

## 110-120 VAC Grounded Tools: Tools with Three Prong Plugs

1. In the event of a malfunction or breakdown, grounding provides a path of least resistance for electric current to reduce the risk of electric shock. This tool is equipped with an electric cord having an equipment-grounding conductor and a grounding plug. The plug must be plugged into a matching outlet that is properly installed and grounded in accordance with all local codes and ordinances.
2. Do not modify the plug provided – if it will not fit the outlet, have the proper outlet installed by a qualified electrician.
3. Improper connection of the equipment-grounding conductor can result in a risk of electric shock. The conductor with insulation having an outer surface that is green with or without yellow stripes is the equipment-grounding conductor. If repair or replacement of the electric cord or plug is necessary, do not connect the equipment-grounding conductor to a live terminal.
4. Check with a qualified electrician or service personnel if the grounding instructions are not completely understood, or if in doubt as to whether the tool is properly grounded.
5. Use only 3-wire extension cords that have 3-prong grounding plugs and 3-pole receptacles that accept the tool's plug.
6. Repair or replace damaged or worn cord immediately.

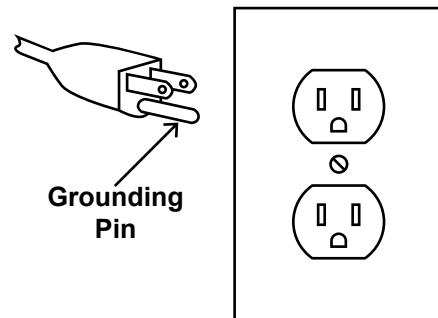

**Figure A: 125 VAC 3-Prong Plug and Outlet (for up to 125 VAC and up to 15 A)**

7. This tool is intended for use on a circuit that has an outlet that looks like the one illustrated above in **Grounding**. The tool has a grounding plug that looks like the plug illustrated above in **Grounding**.
8. The outlet must be properly installed and grounded in accordance with all codes and ordinances.
9. Do not use an adapter to connect this tool to a different outlet.
10. The tool must be plugged into an appropriate outlet, properly installed and grounded in accordance with all codes and ordinances. The plug and outlet should look like those in the preceding illustration. **(See 3-Prong Plug and Outlet.)**

## Miter Saw Safety Warnings

**For Your Own Safety Read Instruction Manual Before Operating Miter Saw**

1. Wear eye protection.
2. Keep hands out of path of saw blade.
3. Do not operate saw without guards in place.
4. Do not perform any operation freehand.
5. Never reach around saw blade.
6. Turn off tool and wait for saw blade to stop before moving workpiece or changing settings.
7. Disconnect power before changing blade or servicing.

## Miter Saw Safety Warnings (continued)

8. Return all guards to original position if any are moved during blade replacement. Check all guards for proper operation after service.
9. Always use blades with correct size and shape (diamond versus round) of arbor holes. Blades that do not match the mounting hardware of the saw will run eccentrically, causing loss of control.
10. Never use damaged or incorrect blade washers or bolt. The blade washers and bolt were specially designed for your saw, for optimum performance and safety of operation.
11. Do not use to cut logs, tree limbs, or uneven lumber.
12. Wet lumber, green (unseasoned) lumber, and pressure treated lumber all have an increased potential for kickback and should only be cut with a blade for cutting that lumber type. Wear a NIOSH-approved respirator and have appropriate ventilation whenever cutting pressure treated lumber.
13. Do not use blades made from high-speed steel, abrasive blades, metal-cutting blades or masonry-cutting blades. The guards of this saw are not designed to protect against the failure of such blades.
14. Blades must be rated to at least the maximum speed marked on the tool.
15. **DO NOT OPERATE WITH ANY GUARD DISABLED, DAMAGED, OR REMOVED. Moving guards must move freely and close instantly.**
16. The use of accessories or attachments not recommended by the manufacturer may result in a risk of injury to persons.
17. When servicing use only identical replacement parts.
18. Do not depress the Spindle Lock when starting or during operation.
19. Only use safety equipment that has been approved by an appropriate standards agency. Unapproved safety equipment may not provide adequate protection. Eye protection must be ANSI-approved and breathing protection must be NIOSH-approved for the specific hazards in the work area.
20. Stay alert, watch what you are doing and use common sense when operating a power tool. Do not use a power tool while you are tired or under the influence of drugs, alcohol or medication. A moment of inattention while operating power tools may result in serious personal injury.
21. Industrial applications must follow OSHA guidelines.
22. Maintain labels and nameplates on the tool. These carry important safety information. If unreadable or missing, contact Harbor Freight Tools for a replacement.
23. Avoid unintentional starting. Prepare to begin work before turning on the tool.
24. People with pacemakers should consult their physician(s) before use. Electromagnetic fields in close proximity to heart pacemaker could cause pacemaker interference or pacemaker failure.
25. The warnings, precautions, and instructions discussed in this instruction manual cannot cover all possible conditions and situations that may occur. It must be understood by the operator that common sense and caution are factors which cannot be built into this product, but must be supplied by the operator.

## Vibration Safety

This tool vibrates during use. Repeated or long-term exposure to vibration may cause temporary or permanent physical injury, particularly to the hands, arms and shoulders. To reduce the risk of vibration-related injury:

1. Anyone using vibrating tools regularly or for an extended period should first be examined by a doctor and then have regular medical check-ups to ensure medical problems are not being caused or worsened from use. Pregnant women or people who have impaired blood circulation to the hand, past hand injuries, nervous system disorders, diabetes, or Raynaud's Disease should not use this tool. If you feel any medical or physical symptoms related to vibration (such as tingling, numbness, and white or blue fingers), seek medical advice as soon as possible.
2. Do not smoke during use. Nicotine reduces the blood supply to the hands and fingers, increasing the risk of vibration-related injury.
3. Use tools with the lowest vibration when there is a choice between different processes.
4. Include vibration-free periods each day of work.
5. Grip tool as lightly as possible (while still keeping safe control of it). Let the tool do the work.
6. To reduce vibration, maintain the tool as explained in this manual. If any abnormal vibration occurs, stop use immediately.

# Symbology

SAFETY

	Double Insulated
<b>V</b>	Volts
~	Alternating Current
<b>A</b>	Amperes
n <sub>0</sub> xxxx/min.	No Load Revolutions per Minute (RPM)

	WARNING marking concerning Risk of Eye Injury. Wear ANSI-approved safety goggles with side shields.
	Read the manual before set-up and/or use.
	WARNING marking concerning Risk of Fire. Do not cover ventilation ducts. Keep flammable objects away.
	WARNING marking concerning Risk of Electric Shock. Properly connect power cord to appropriate outlet.



**SAVE THESE INSTRUCTIONS.**

SETUP

OPERATION

MAINTENANCE

## Specifications

Electrical Rating	120 VAC / 60 Hz / 15 A	
Motor No Load Speed	4800 RPM	
Arbor Diameter	5/8"	
Recommended Blade Type	General Purpose with Carbide Tips	
Maximum Blade Diameter	10"	
Positive Table Stops	0°, 15°, 22.5°, 30° and 45° Left and Right	
Positive Bevel Stops	0° and 45° Left only	
Blade Tilt Range	0°– 45° Left and Right Miter 0°– 45° Left Bevel	
Scale	1° per scale mark	
Cutting Capacity	90° Straight cut	2-3/4" Deep x 12" Wide
	45° Miter cut	2-3/4" Deep x 8-1/4" Wide
	45° Straight Bevel cut	1-9/16" Deep x 12" Wide
	45° Compound cut L/R	1-9/16" Deep x 8-1/4" Wide

## List of Contents

Description	Qty
Compound Sliding Miter Saw	1
Carbon Brush Set	1
Table Extensions	2
Dust Collection Bag	1
Hex Key	1

## Setup - Before Use:



Read the **ENTIRE IMPORTANT SAFETY INFORMATION** section at the beginning of this manual including all text under subheadings therein before set up or use of this product.

### **WARNING**

**TO PREVENT SERIOUS INJURY FROM ACCIDENTAL OPERATION:** Turn the Power Switch of the tool off and unplug the tool from its electrical outlet before performing any procedure in this section.

**Note:** For additional information regarding the parts listed in the following pages, refer to *Parts List and Diagram* on page 17.

## Assembly

1. Insert the ends of the Table Extensions into the holes in the sides of the Base. Tighten the Wing Screws to hold the Extensions in place. The upper edge of the Extensions will be level with the surface of the saw. This provides a wider base for the work material to rest on.
2. Thread the Miter Knob into the end of the Table below the Miter Lock until securely in place.
3. Slip the Dust Bag over the Dust Outlet at the rear of the saw.

## Mounting the Saw

Use the four bolt holes provided in the Base to mount the Miter Saw to a stable support before use. Mounting hardware not included.

## Functions

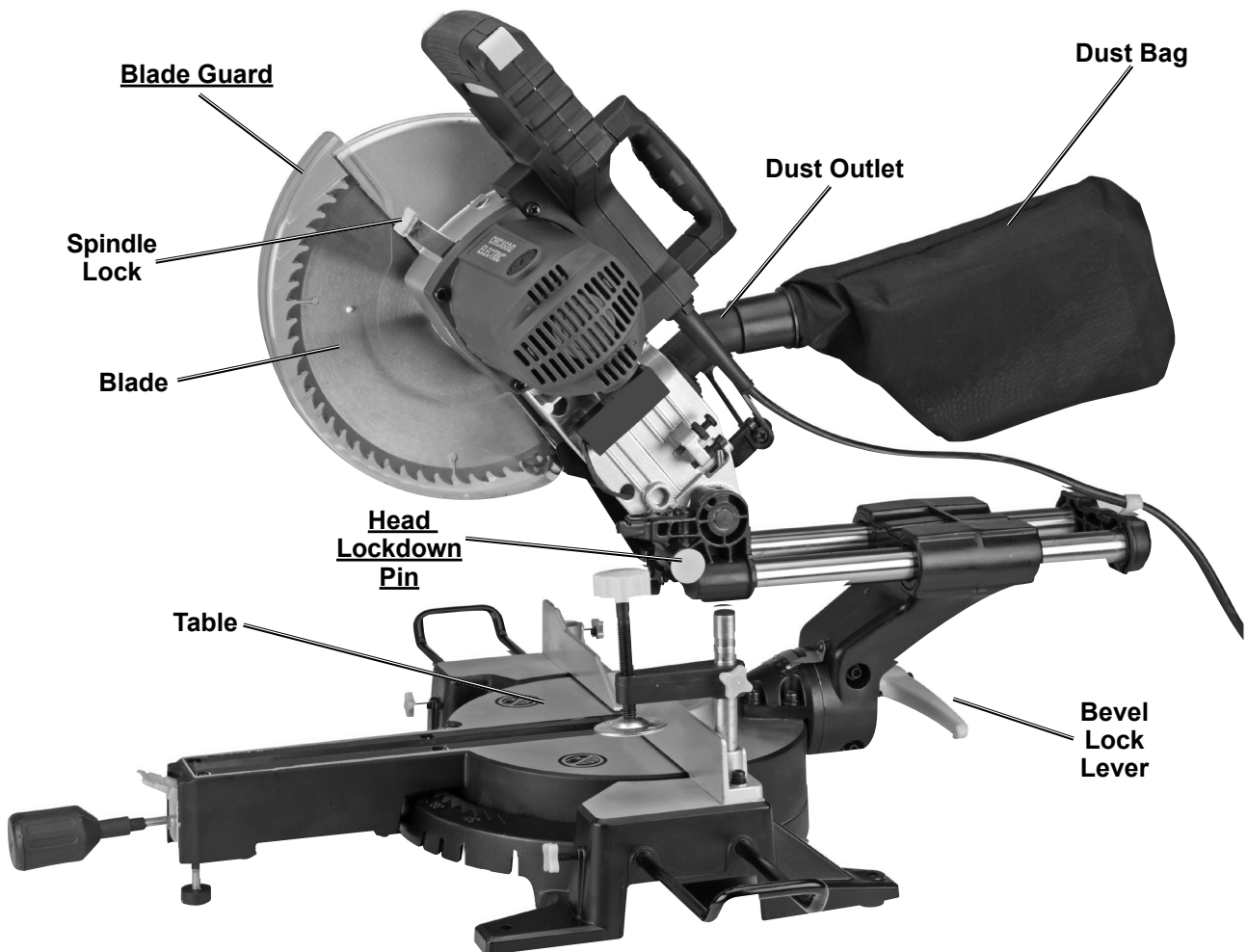



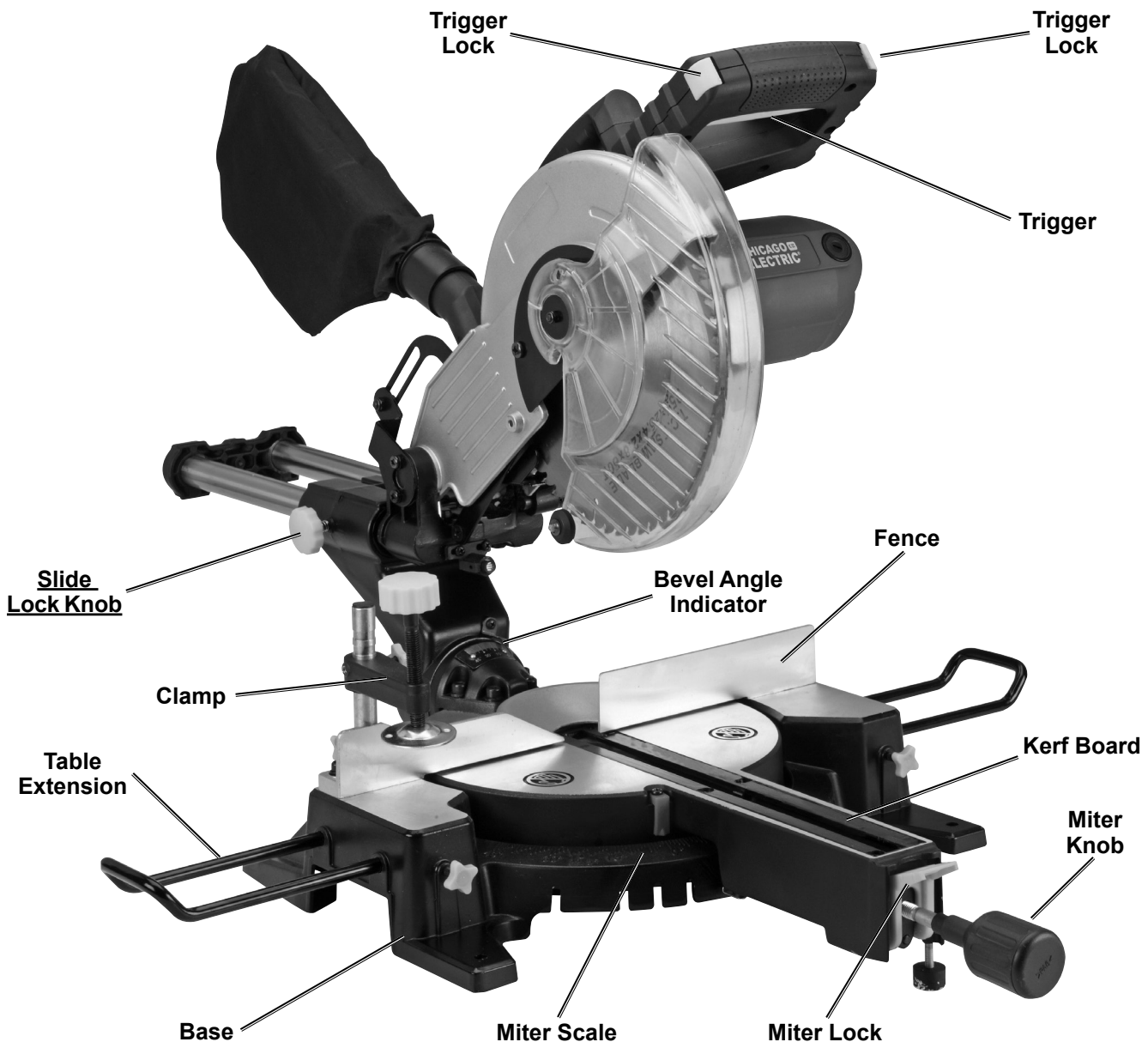

## Description of Selected Functions

### Head Lockdown Pin:

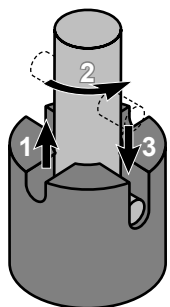

Align pin with **deep groove** to lock cutting head.

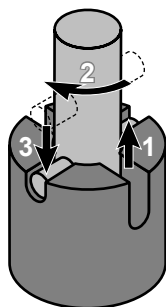

Align pin with **shallow groove** to unlock cutting head.

### Blade Guard operation:

When the cutting head is lowered, the Blade Guard raises automatically. When the cutting head is raised the Blade Guard returns to its safety position. Keep hands clear of the Blade when the Handle is lowered. Do not interfere with the proper movement of the Blade Guard.

### Slide Lock Knob:

Tighten this to prevent the cutting head from sliding back and forth for chopping cuts. Loosen this to allow the cutting head to slide.

**Note:** Additional functions are explained elsewhere in the manual.

## Operating Instructions



Read the **ENTIRE IMPORTANT SAFETY INFORMATION** section at the beginning of this manual including all text under subheadings therein before set up or use of this product.

## TOOL SET UP

### **WARNING**

**TO PREVENT SERIOUS INJURY FROM ACCIDENTAL OPERATION:** Turn the Power Switch of the tool off and unplug the tool from its electrical outlet before performing any procedure in this section.

**TO PREVENT SERIOUS INJURY: DO NOT OPERATE WITH ANY GUARD DISABLED, DAMAGED, OR REMOVED.** Moving guards must move freely and close instantly.

## Replacing the Blade

**Note:** Blade sold separately.

1. Unplug the tool from its power source.
2. Lock the cutting head in the raised position using the Head Lockdown Pin.
3. Raise the Blade Guard (119) up until the recess in the Blade Guard is above the Spindle Bolt (71).
4. Press firmly on the Spindle Lock (96) and use the supplied Hex Key (70) to slowly rotate the Spindle Bolt\* **CLOCKWISE**. The Spindle Lock will engage within one rotation.

**\*IMPORTANT:** The Spindle Bolt has a left-handed thread and removes by turning **CLOCKWISE**.

5. Continue to press in the Spindle Lock and remove the Spindle Bolt (71), Washer (72) and Outer Flange (73) – see Figure C.

**Note:** Make sure the Inner Flange (76) stays in place on the Spindle.

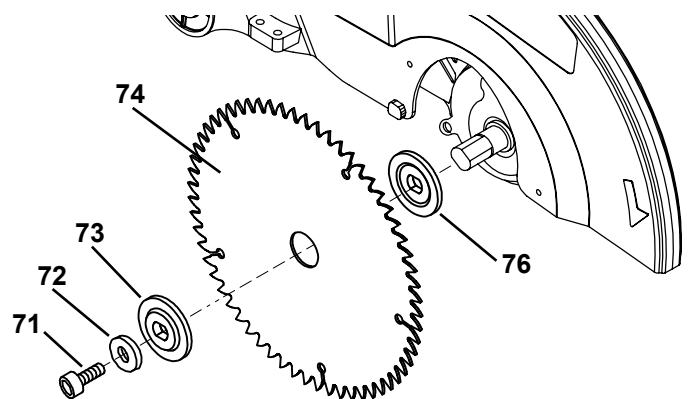

Figure C

6. Remove the Blade (74). Install the new Blade. Make sure that the Blade's rotation arrow points in the same direction as the rotation arrow on the Saw Head (86).
7. Replace the Outer Flange, Washer and Spindle Bolt. Position the cupped side of the Flange against the blade. Hold in the Spindle Lock and wrench-tighten the Spindle Bolt by turning it **COUNTERCLOCKWISE**. Release the Spindle Lock.
8. Move the Blade Guard back into place.

**WARNING!** Make sure the Blade Guard operates smoothly and properly protects from the Blade before using the saw.

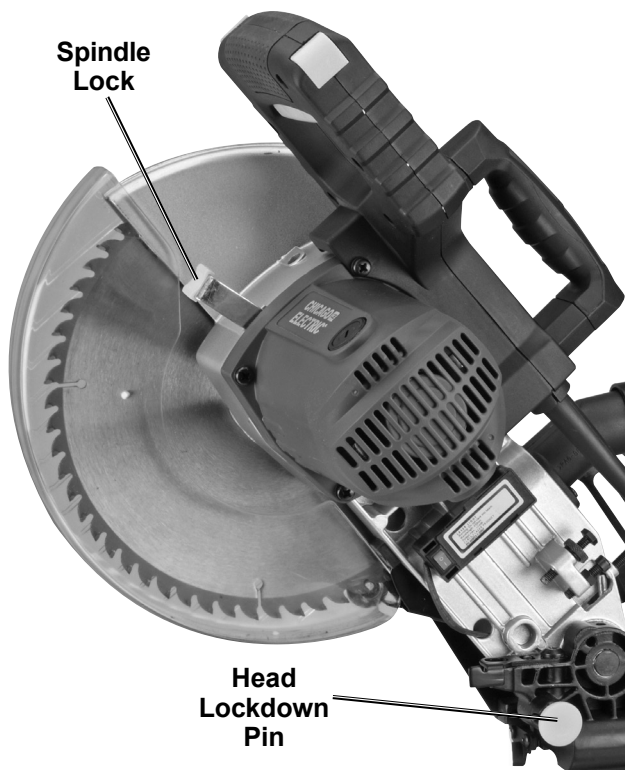

Figure B

## Using the Workpiece Extension Supports

1. The Table Extensions are inserted into each side of the Base, and locked in place using the Wing Screws.
2. When properly installed, the upper face of the Table Extensions are level with the Table, and provide a wider support surface for the workpiece.
3. Support the workpiece to be level with the Table, and so that after the cut is made the cut off pieces will not fall. Use sawhorses or other supports (not included) to support longer workpieces.
4. If the workpiece is not level, an unintentional bevel cut will be made in the material. If the workpiece is not supported, it will bind the blade and may cause the material to kick back, potentially causing injury.

## Adjusting the Miter Angle

A miter cut is one that is at an angle across the horizontal surface of the material. 45° miter cuts to join two pieces in a right angle corner are common. A 30° cut is often used for a scarf joint or to make a chamfered end.

1. Loosen the Miter Knob by turning it approximately 2 turns counterclockwise.
2. Press down the Miter Lock to unlock the Table. While holding the Miter Lock down, move the Table to the desired angle.
3. The Miter Angle Indicator will indicate the selected angle. While the Miter Lock is released, the table will lock into place at often used miter angles, including 22.5°, 30°, 45°, and 90° on both left and right sides.
4. Tighten the Miter Knob after adjusting the miter angle.
5. With the Table adjusted to the desired angle, place the workpiece flush against the Fence, secure it with the Clamp and make the cut.

## Adjusting the Bevel Angle

A bevel cut is one that is at an angle vertically. Bevel cuts can be used to cut a miter in relatively wide and thin material. Bevel cuts can be used in combination with a miter cut to form a compound angle. Compound angle cuts are often used in crown moldings, picture frames and similar trim materials.

1. Loosen the Bevel Lock Lever at the rear of the saw.
2. Move the blade assembly to the desired angle. Read the angle on the Bevel Angle Indicator.
3. Lock the blade assembly into position by rotating the Bevel Lock Lever clockwise. Tighten firmly but do not over-tighten.
4. Make a sample cut in a piece of scrap to confirm that the bevel angle is correct. If it is not, correct the angle before cutting.

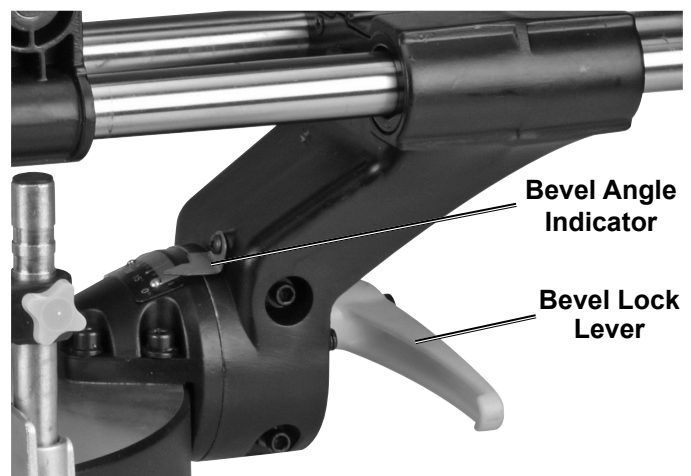

Figure D

## Using the Depth Stop

If a kerfing or rabbet cut which does not cut through the workpiece is desired, use the Depth Stop Bolt to control the depth of the cut.

**WARNING!** Only adjust the front Depth Stop Bolt. The rear Bolt is used to prevent the Blade from cutting the Table during normal cutting. Do not adjust the rear Depth Bolt.

1. Unlock the Head Lockdown Pin – see page 9.
2. Raise the saw head assembly.
3. **Push the Depth Stop to the right to use the Depth Stop Bolt setting.**
4. Pull down on the saw head to check the current setting.
5. To change the setting, first loosen the knurled Depth Adjustment Nut on the Depth Stop Bolt. Turn the Depth Stop Bolt clockwise to decrease depth and counterclockwise to increase depth. Tighten the Depth Adjustment Nut down against the saw housing after setting depth.
6. **If needed, push the Depth Stop to the left to temporarily disable it.**

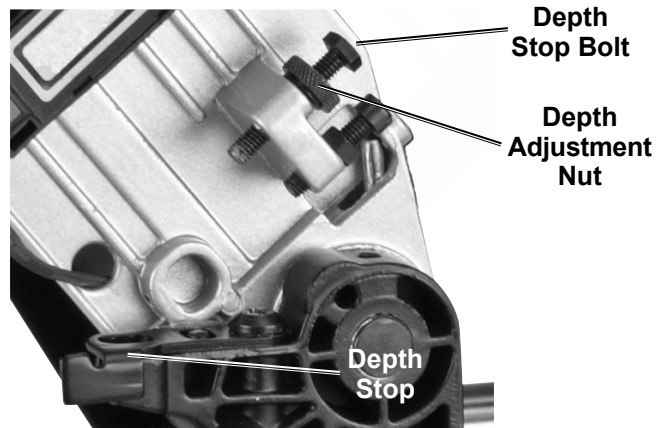

Figure E

## Workpiece and Work Area Set Up

1. Designate a work area that is clean and well lit. The work area must not allow access by children or pets to prevent distraction and injury.
2. Route the power cord along a safe route to reach the work area without creating a tripping hazard or exposing the power cord to possible damage. The power cord must reach the work area with enough extra length to allow free movement while working.
3. Allow room on both left and right of saw for extended workpieces.
4. Use a saw table, saw stand or other means to support the workpiece. Mount the Miter Saw so that the surface is level to the ground, and additional supports provide a surface on the same level as the saw table. If the work surface and any workpiece supports are not level, and on the same level, unwanted bevel angles will appear in the cuts resulting in poor joinery.
5. Secure workpieces to the saw table using the Clamp or other clamping devices (not included). Securing the workpiece will provide safety by preventing kick back and by removing the need to hold workpieces near the blade by hand. Clamping the workpiece will also improve cutting accuracy by preventing the workpiece from moving during the cutting operation.

## General Operating Instructions

**⚠ DANGER**



**MITER SAWS CAN QUICKLY AMPUTATE FINGERS IF MISUSED.**  
Keep hands well clear of cutting area.

1. Unlock the Head Lockdown Pin. Refer to page 9.
2. Make sure all adjustment knobs are tight (Miter Knob, Bevel Lock Lever, Fence and Table Extension Knobs).
3. Blow any sawdust or debris away from the Fence. Place the work material against the Fence.
4. Align the marked location of the cut on the work material with the saw blade.

**Note:** To prevent your workpiece from being cut too short, align the edge of the Blade with your measured mark, keeping the rest of the Blade on the waste side of the cut.

5. Hold the work material in place using the Clamp. Ensure that the work material is level and supported securely. Use saw horses or supports if necessary.
6. Grip the Saw Handle, press one of the Trigger Locks with your thumb, and squeeze the Trigger to start the Saw.
7. With narrow material, press down lightly to cut the workpiece. Press straight down, “chopping” the material. Do not bear down on the material—use light downward pressure. If the material binds the blade, release the Trigger.

8. With wide material, move the Blade across the workpiece while cutting as follows:
  - a. Loosen Slide Lock Knob and pull Saw Head Assembly forward.
  - b. Press down on the Saw Handle.
  - c. Push the Saw Head toward the rear to make the cut. Refer to Figure G.

Do not bear down on the material—use light downward and lateral pressure. If the material binds the blade, release the Trigger.

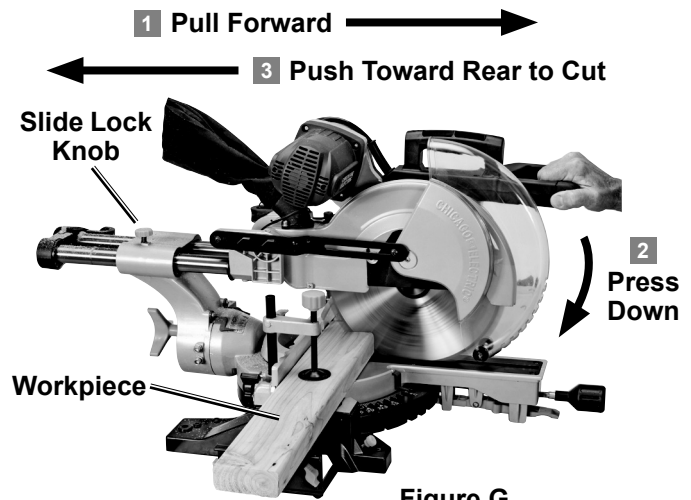

9. When the cut is completed, raise the Saw Head, release the Trigger and wait for the Blade to stop turning. Release the Clamp and remove the workpiece from the Saw.
10. To prevent accidents, turn off the tool and disconnect its power supply after use. Clean, then store the tool indoors out of children's reach.

**CHICAGO**  **ELECTRIC®**  
**POWER TOOLS**

## Maintenance and Servicing



Procedures not specifically explained in this manual must be performed only by a qualified technician.

### **WARNING**

**TO PREVENT SERIOUS INJURY FROM ACCIDENTAL OPERATION:**

Turn the Power Switch of the tool off and unplug the tool from its electrical outlet before performing any procedure in this section.

**TO PREVENT SERIOUS INJURY FROM TOOL FAILURE:**

Do not use damaged equipment. If abnormal noise or vibration occurs, have the problem corrected before further use.

SAFETY

## Cleaning, Maintenance, and Lubrication

1. **BEFORE EACH USE**, inspect the general condition of the tool. Check for:
  - loose hardware
  - misalignment or binding of moving parts
  - damaged cord/electrical wiring
  - cracked or broken parts
  - any other condition that may affect its safe operation.
2. **AFTER USE**, wipe external surfaces of the tool with clean cloth.
3. **WARNING!** If the supply cord of this power tool is damaged, it must be replaced only by a qualified service technician.

SETUP

## Checking and Calibrating the Fence

The Fence holds the workpiece in a fixed position while the Table and/or the blade assembly are adjusted in a miter or bevel angle.

To make accurate cuts, the Fence must be perpendicular (at a 90° angle) to the Saw Blade.

1. Before beginning work, make a test cut on scrap material with the Table set at 90°.
2. Check the cut with an accurate square. You can also reverse the two pieces, hold the cut ends together, and hold a good straight edge along the side of the pieces.
3. If either test reveals that the cut is not a true 90° angle, adjust the Fence before beginning work.

### **If Fence needs adjustment:**

1. First unplug the tool.
2. Lower the blade assembly and lock it in place using the Head Lockdown Pin.
3. Lay a carpenter's square on the Table with one edge along the Blade and the other along the Fence. Any inaccuracy should be visible.

**NOTE:** The square must contact the surface of the Blade, not the teeth, for an accurate reading.

4. The Fence is held in place with bolts at each end. Loosen the bolts slightly, and gently tap the Fence into position using a soft mallet. Retighten the bolts and make another test cut. Repeat the process until the Fence is adjusted accurately.
5. Once the Fence is accurately adjusted, tighten the bolts firmly in place. Recheck one last time, then proceed to work.

OPERATION

MAINTENANCE

## Calibrating the Miter Angle Indicator

After checking or adjusting the Fence to confirm that it is at 90° to the Blade, check the accuracy of the Miter Angle Indicator.

1. Loosen the screw holding the Angle Indicator in place.
2. Rotate it until the pointer is exactly on 90°.
3. Retighten the screw.

## Calibrating the Bevel Angle

For making accurate cuts, the Saw Blade must be adjusted to be exactly vertical to the Table.

1. To check the angle, have the blade assembly in its normal upright position. Make a cut on a piece of flat sided, fairly thick scrap material.
2. Check the cut with an accurate square. The cut should be at exactly 90°.
3. Angle can also be checked by rotating one cut-off piece 180° and holding the cut ends together. If the cut is not exactly vertical, the two pieces will form a slight angle.
4. If necessary, the bevel angle can be corrected by adjusting the Bevel Adjustment Screw on the right side under the Bevel Locking Lever.
5. Once the bevel angle is adjusted, adjust the Bevel Angle Indicator to read 0° when the Saw Blade is in the vertical position. Loosen the screw holding the Indicator in place, adjust it to be exactly over the 0° mark, then retighten the screw.

## Adjusting or Replacing the Kerf Board

If the Kerf Board becomes damaged it must be replaced.

### **To adjust the Kerf Board:**

1. Remove the four screws holding the Kerf Board in place.
2. Install a new Kerf Board. Replace the four screws and tighten them slightly.
1. Lower the blade assembly and lock it down with the Head Lockdown Pin.
2. Adjust the Kerf Board so the right side of the Blade slightly clears the edge of the Kerf Board.
3. Loosen the Bevel Locking Lever and set the bevel angle at 45° left.
4. Ensure that the left side of the Blade clears the Kerf Board.
5. Tighten the four screws holding the Kerf Board in place.

# Troubleshooting

SAFETY

SETUP

OPERATION

MAINTENANCE

Problem	Possible Causes	Likely Solutions
Tool will not start	<ol style="list-style-type: none"> <li>1. No power at outlet.</li> <li>2. Cord not connected.</li> </ol>	<ol style="list-style-type: none"> <li>1. Check power at outlet.</li> <li>2. Check that cord is plugged in.</li> </ol>
Tool operates sporadically or at low power	<ol style="list-style-type: none"> <li>1. Low power supply or improper extension cords.</li> <li>2. Worn or cracked Carbon Brushes.</li> </ol>	<ol style="list-style-type: none"> <li>1. Check power supply and power cords.</li> <li>2. Check Carbon Brushes. Replace if damaged or worn.</li> </ol>
Wood burns at ends when cut	<ol style="list-style-type: none"> <li>1. Dirty Blade.</li> <li>2. Material is binding.</li> </ol>	<ol style="list-style-type: none"> <li>1. Clean Blade using blade cleaner or mineral spirits.</li> <li>2. Check position of work material on Table. Material must be flat, flush against Fence and supported on ends.</li> </ol>
Material frays or chips out.	<ol style="list-style-type: none"> <li>1. Finished side is down.</li> <li>2. Blade chipped or dull.</li> <li>3. Blade inappropriate for material.</li> <li>4. Material is unsupported.</li> </ol>	<ol style="list-style-type: none"> <li>1. Keep finished side of material up or facing operator. Bottom and back side are prone to chip out.</li> <li>2. Check for damaged teeth. Sharpen or replace blade.</li> <li>3. Check blade manufacturer's recommendations for material being cut. For cross cutting hard wood and for precision cuts use a thin kerf blade with 60 or more teeth.</li> <li>4. Use a thin piece of scrap material, such as 1/4" plywood, underneath or behind the material to support the edges of the material as it is being cut.</li> </ol>
Blade binds, slowing or stopping saw.	<ol style="list-style-type: none"> <li>1. Material is misaligned on the saw or ends are not supported.</li> <li>2. Material is wet, contaminated or inappropriate blade is being used.</li> </ol>	<ol style="list-style-type: none"> <li>1. Material must be flat on table, flush against the fence and supported on both ends.</li> <li>2. Check condition of material and check compatibility of blade to material.</li> </ol>
 <p><b>Follow all safety precautions whenever diagnosing or servicing the tool. Disconnect power supply before service.</b></p>		



### PLEASE READ THE FOLLOWING CAREFULLY

THE MANUFACTURER AND/OR DISTRIBUTOR HAS PROVIDED THE PARTS LIST AND ASSEMBLY DIAGRAM IN THIS MANUAL AS A REFERENCE TOOL ONLY. NEITHER THE MANUFACTURER OR DISTRIBUTOR MAKES ANY REPRESENTATION OR WARRANTY OF ANY KIND TO THE BUYER THAT HE OR SHE IS QUALIFIED TO MAKE ANY REPAIRS TO THE PRODUCT, OR THAT HE OR SHE IS QUALIFIED TO REPLACE ANY PARTS OF THE PRODUCT. IN FACT, THE MANUFACTURER AND/OR DISTRIBUTOR EXPRESSLY STATES THAT ALL REPAIRS AND PARTS REPLACEMENTS SHOULD BE UNDERTAKEN BY CERTIFIED AND LICENSED TECHNICIANS, AND NOT BY THE BUYER. THE BUYER ASSUMES ALL RISK AND LIABILITY ARISING OUT OF HIS OR HER REPAIRS TO THE ORIGINAL PRODUCT OR REPLACEMENT PARTS THERETO, OR ARISING OUT OF HIS OR HER INSTALLATION OF REPLACEMENT PARTS THERETO.

### Parts List

Part	Description	Qty
1	Table Extension	2
2	6x15 Wing Screw	2
3	Rubber Foot	4
4	Base	1
5	M8x50 Hex Bolt	1
6	Turntable Plate	3
7	Table	1
8	Ø5 Spring Washer	2
9	M5x10 Cross Pan Head Screw	4
10	Small Spring	1
11	Miter Angle Rod	1
12	Lateral Pin	1
13	Miter Knob	1
14	Miter Lock	1
15	Bracket	1
16	Friction Plate	1
17	Miter Angle Indicator	1
18	M5x12 Cross Pan Head Screw	3
19	M5x8 Cross Pan Head Screw	8
20	Kerf Board	1
21	Ø8 Flat Washer	1
22	M6 Lock Nut	1
23	Ø2.5x4 Rivet	2
24	Bevel Scale	1
25	M10x55 Double Head Bolt	1
26	M10x50 Double Head Bolt	1
27	M4x6 Cross Head Screw	1
28	Rubber Screw	1
29	M6x30 Inner Hex Screw	1
30	Bevel Angle Indicator	1
31	M6x25 Inner Hex Screw	6
32	M6 Nut	2
33	Ø6 Flat Washer	5
34	Angle Adjusting Spring	1
35	Ø10 Flat Washer	2
36	M10 Lock Nut	1
37	Bevel Lock Lever	1

Part	Description	Qty
38	Rubber Plug	2
39	Bearing Cover	2
40	Pin Cover	4
41	M6x25 Slide Lock Knob	1
42	Slide Lock Spring	1
43	Turntable Support	1
44	Saw Head Lockdown Knob	1
45	Saw Head Lockdown Spring	1
46	Saw Head Lockdown Pin	1
47	M6x8 Inner Hex Screw	5
48	Bevel Hinge	1
49	Ø3x16 Roll Pin	1
50	Fence	1
51	Hinge Pin	1
52	Torsion Spring	1
53	Hinge Pin Support	1
54	Ø6 Spring Washer	5
55	M6x14 Cross Pan Head Screw	2
56	Depth Stop	1
57	Ø8 Wave Washer	1
58	Hemispherical Head Screw	1
59	Slide Rail	2
60	Ø25xØ40x35 Linear Bearing	4
61	Bracket Cover	1
62	Cable Clamp	1
63	M4x8 Cross Pan Head Screw	2
64	Clamp Locating Pin	1
65	Clamp Connecting Bar	1
66	M5 Non-Standard Screw w/Step	1
67	Clamp Press Plate	1
68	Ø5 Flat Washer	1
69	Clamp	1
70	Hex Key	1
71	M8x16 Spindle Bolt (LH thread)	1
72	Ø8 Flat Washer	1
73	Outer Flange	1
74	Blade (sold separately)	-

## Parts List (continued)

SAFETY

SETUP

OPERATION

MAINTENANCE

Part	Description	Qty
76	Inner Flange	1
77	M5x16 Cross Pan Head Screw	2
78	Bearing Cover	1
79	Spindle	1
80	Woodruff Key 4	1
81	6023 Bearing	1
82	Bearing Housing	1
83	Large Gear	1
84	Ø17 Circlip	1
85	HK121610 Needle Bearing	1
86	Saw Head	1
87	M4x8 Screw	2
88	Saw Head Bracket	1
89	M5x10 Screw	1
90	Rubber Block	1
91	Saw Head Label	1
92	Depth Adjustment Nut	1
93	M6x35 Depth Stop Bolt	1
94	6202 Bearing	1
95	Rotor Self-Locking Spring	1
96	Spindle Lock	1
97	Spindle Lock Sheath	1
98	Rotor	1
99	Carbon Brush	2
100	6000 Bearing	1
101	Air Seal Ring	1
102	ST4.8x60 Self-Tapping Screw	2
103	Stator	1
104	6x50 Wing Screw	2
105	Bracket	1
106	Turntable Locking Pin	1
107	Miter Lock Support	1
108	Turntable Connector	1
109	Ø8 Spring Washer	4
110	M8x30 Inner Hex Angle Screw	4
111	Dust Outlet	1
112	Dust Bag	1
113	M6 Lock Nut	1

Part	Description	Qty
114	Connecting Bar	1
115	M5 Lock Nut	2
116	Connecting Bar Bushing	1
117	Non-Standard Screw	1
118	Washer	1
119	Blade Guard	1
120	Blade Guard Spring	1
121	M6x8 Cross Pan Head Screw	2
122	Blade Guard Pivot Plate	1
123	Blade Guard Locating Board	1
124	M5x20 Cross Pan Head Screw	2
125	M6x10 Screw	2
126	Short Link Bar	1
127	Blade Guard Roller	2
128	Ø5 Retaining Ring	2
129	Half Ball Shaft Shoulder Screw	1
130	ST6x18 Self-Tapping Screw	2
131	Lift Handle	1
132	ST3.9x16 Self-Tapping Screw	6
133	Upper Handle	1
134	M5x40 Cross Pan Head Screw	2
135	Power Cord	1
136	Cable Sleeve	1
137	ST3.9x14 Self-Tapping Screw	2
138	Power Cord Clamp	1
139	Lower Handle	1
140	Locking Pin	2
141	Trigger Lock Connector	1
142	Right Trigger Lock Button	1
143	Trigger	1
144	Switch	1
145	Left Trigger Lock Button	1
146	Switch Torsion Spring	1
147	Motor Housing Label	1
148	Motor Housing	1
149	Brush Holder	1
150	Brush Holder Cap	1
151	M6x35 Cross Pan Head Screw	4

Record Product's Serial Number Here: \_\_\_\_\_

**Note:** If product has no serial number, record month and year of purchase instead.

**Note:** Some parts are listed and shown for illustration purposes only, and are not available individually as replacement parts.

# Assembly Diagram

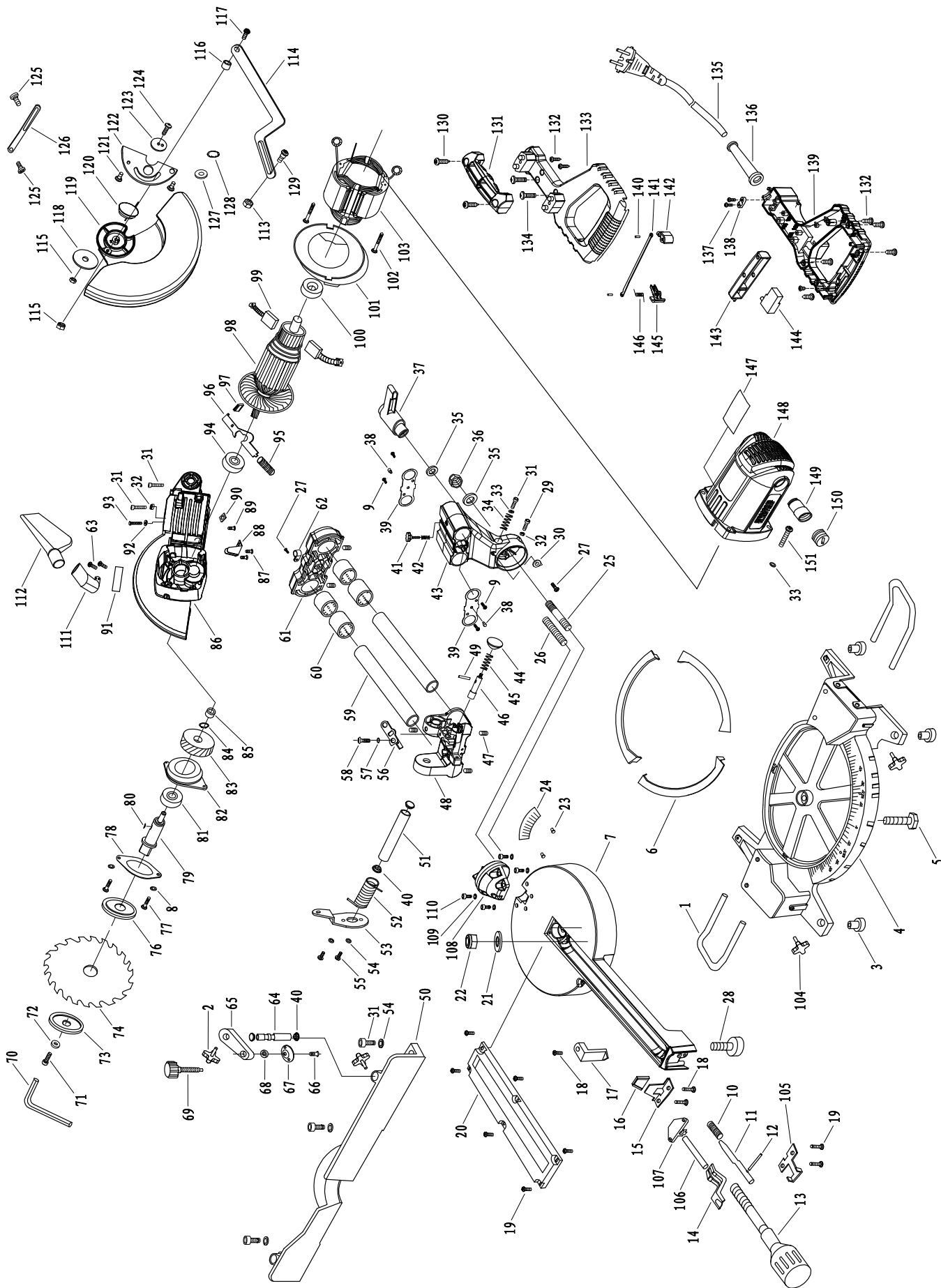

SAFETY

SETUP

OPERATION

MAINTENANCE

## Limited 90 Day Warranty

Harbor Freight Tools Co. makes every effort to assure that its products meet high quality and durability standards, and warrants to the original purchaser that this product is free from defects in materials and workmanship for the period of 90 days from the date of purchase. This warranty does not apply to damage due directly or indirectly, to misuse, abuse, negligence or accidents, repairs or alterations outside our facilities, criminal activity, improper installation, normal wear and tear, or to lack of maintenance. We shall in no event be liable for death, injuries to persons or property, or for incidental, contingent, special or consequential damages arising from the use of our product. Some states do not allow the exclusion or limitation of incidental or consequential damages, so the above limitation of exclusion may not apply to you. THIS WARRANTY IS EXPRESSLY IN LIEU OF ALL OTHER WARRANTIES, EXPRESS OR IMPLIED, INCLUDING THE WARRANTIES OF MERCHANTABILITY AND FITNESS.

To take advantage of this warranty, the product or part must be returned to us with transportation charges prepaid. Proof of purchase date and an explanation of the complaint must accompany the merchandise. If our inspection verifies the defect, we will either repair or replace the product at our election or we may elect to refund the purchase price if we cannot readily and quickly provide you with a replacement. We will return repaired products at our expense, but if we determine there is no defect, or that the defect resulted from causes not within the scope of our warranty, then you must bear the cost of returning the product.

This warranty gives you specific legal rights and you may also have other rights which vary from state to state.

**CHICAGO  ELECTRIC<sup>®</sup>**  
**POWER TOOLS**

26541 Agoura Road • Calabasas, CA 91302 • 1-888-866-5797