

Grotime[®]
Innovating children's furniture

BACKSAVER

3 in 1 cot with drawer



Two adults required to assemble this cot.



The manufacturer's assembly instructions must be followed in detail to ensure the safety features to the cot are not compromised.

HARDWARE INVENTORY

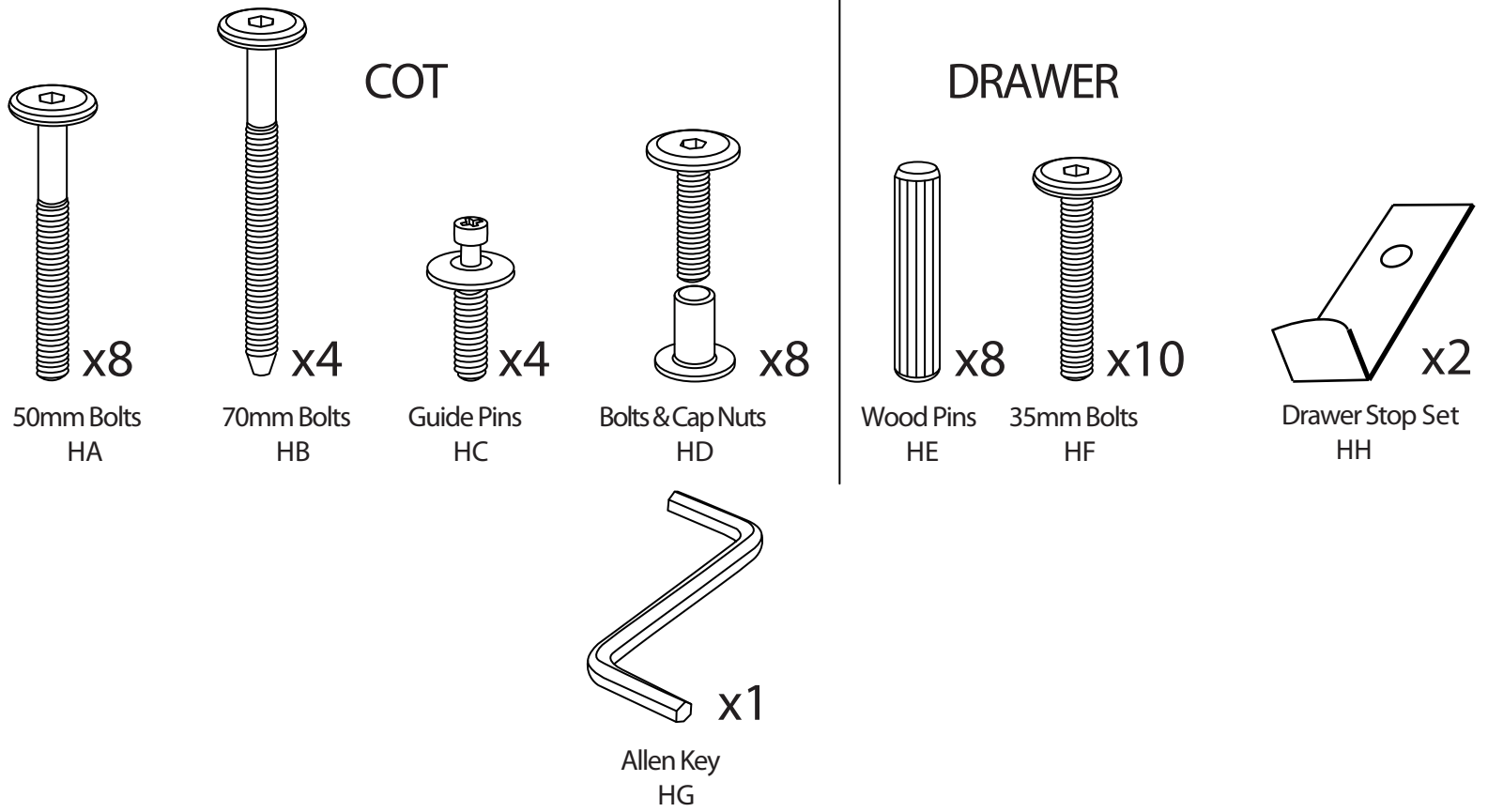

PRE-INSTALLED HARDWARE

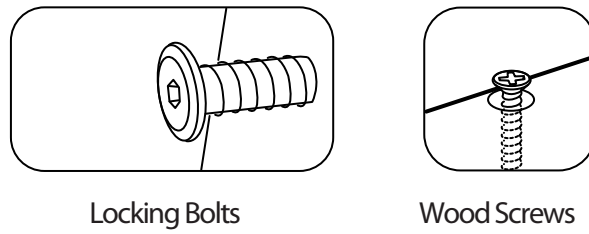

PARTS LIST

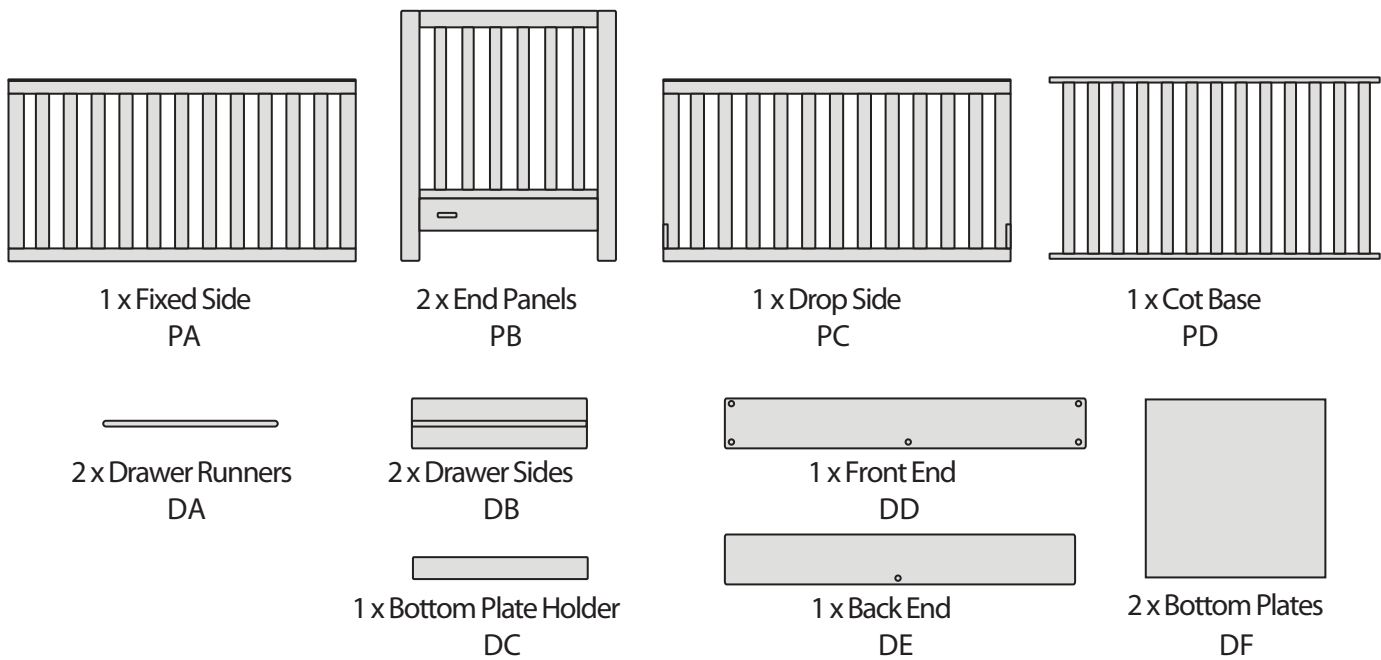

STEP 1

ASSEMBLE COT DRAWER RUNNERS IN THE COT ENDS

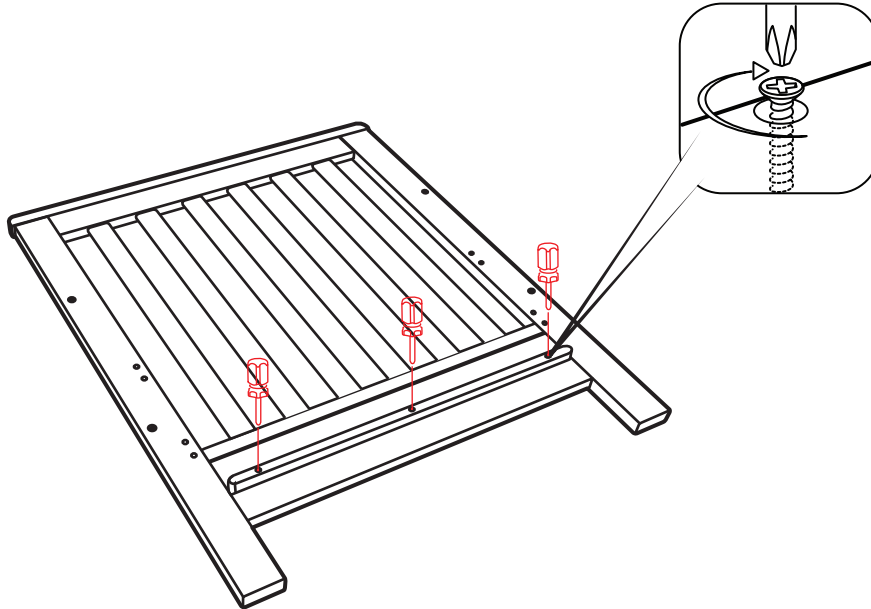
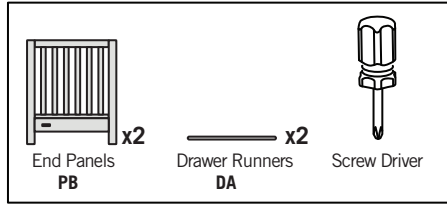

STEP 2

ASSEMBLE THE TWO OUTER ENDS TO THE BASE

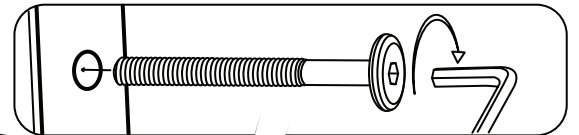
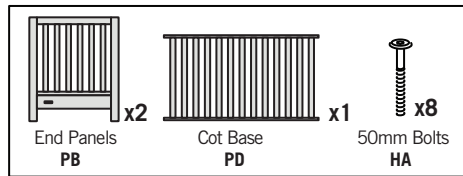

! Do not tighten bolts at this stage

! Chose high or low position for mattress base

HIGH
Bassinet level

LOW
Toddler level

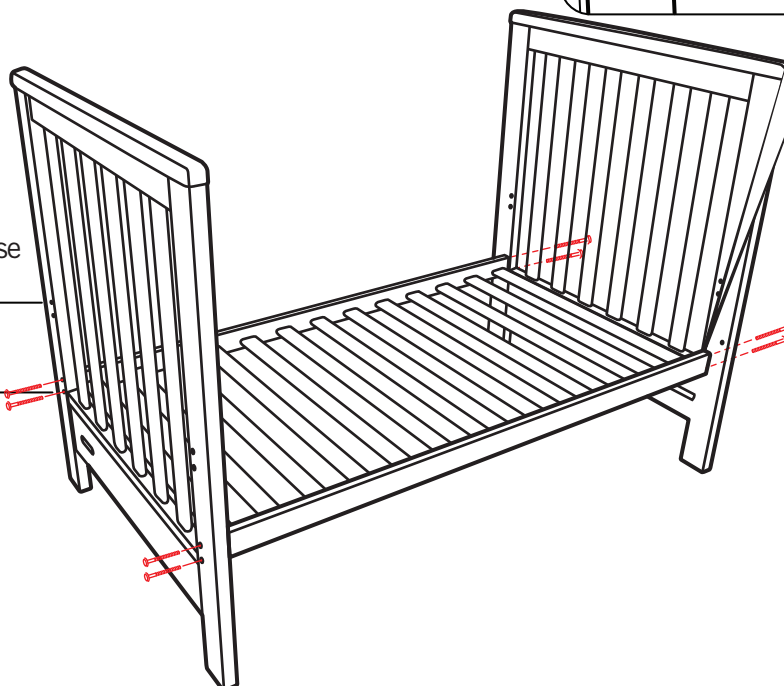

STEP 3

ASSEMBLE FIXED SIDE TO ENDS

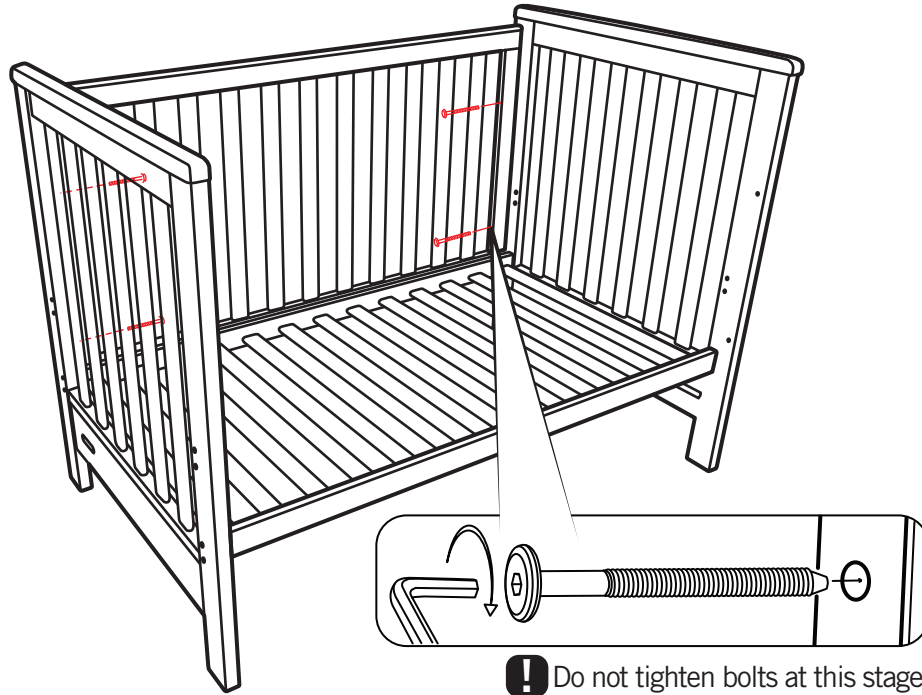
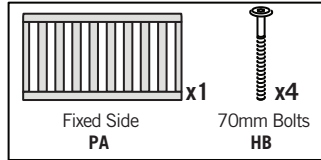

STEP 4

SCREW FOUR GUIDE PINS INTO ENDS FIRMLY

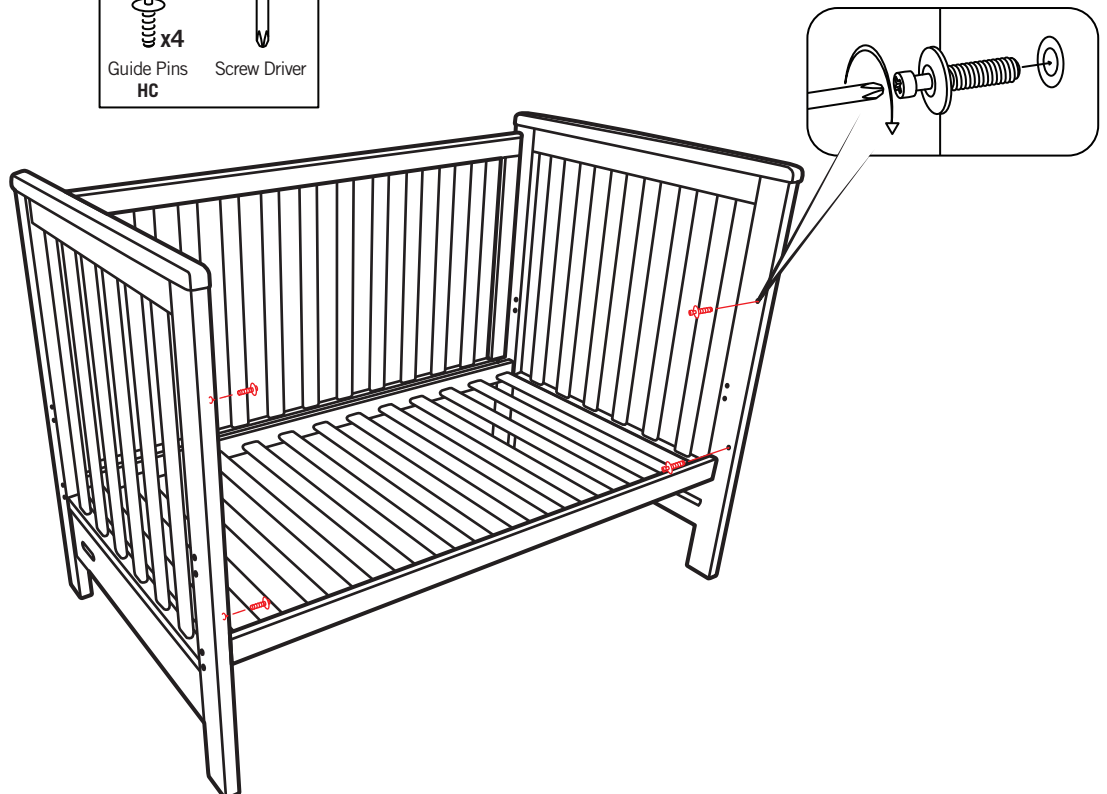
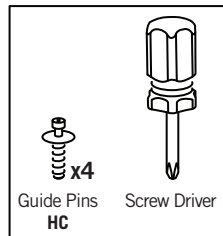

STEP 5 ASSEMBLE DROP SIDE

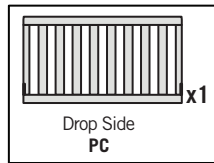

Align two access holes in the built-in runner with the guide pins on one end. Now repeat on other end.



STEP 6 FULLY SCREW IN LOCKING BOLTS

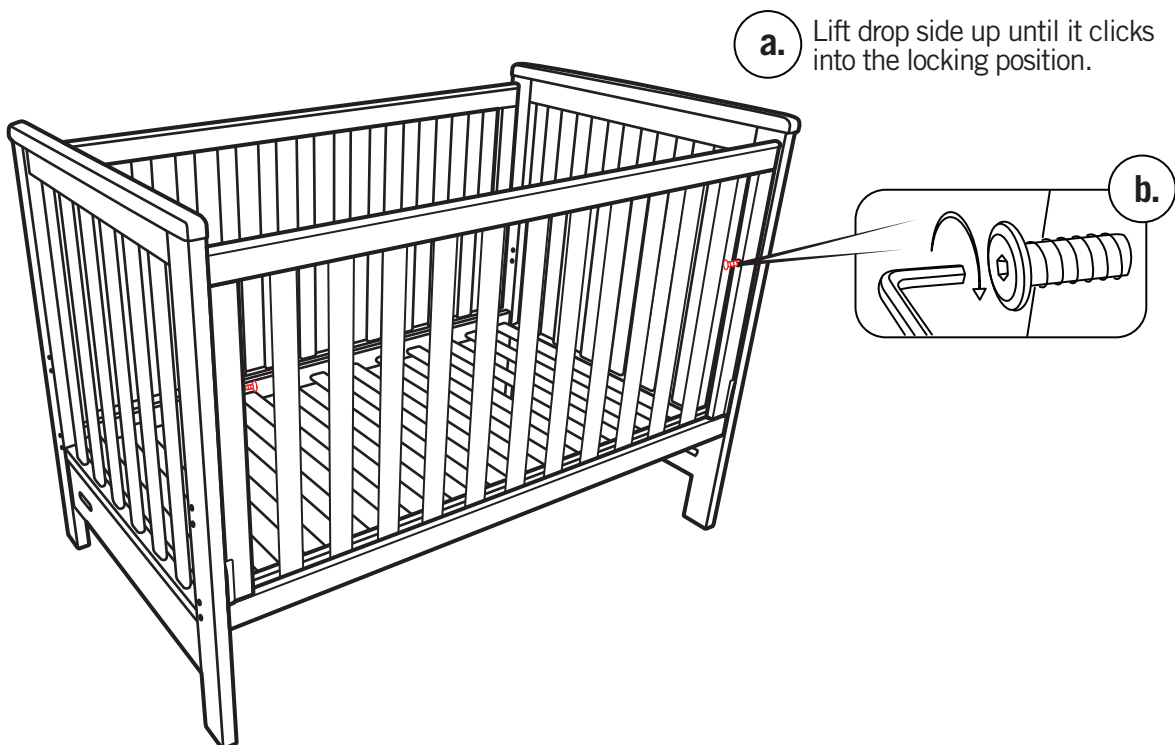

STEP 7

TIGHTEN ALL BOLTS AND

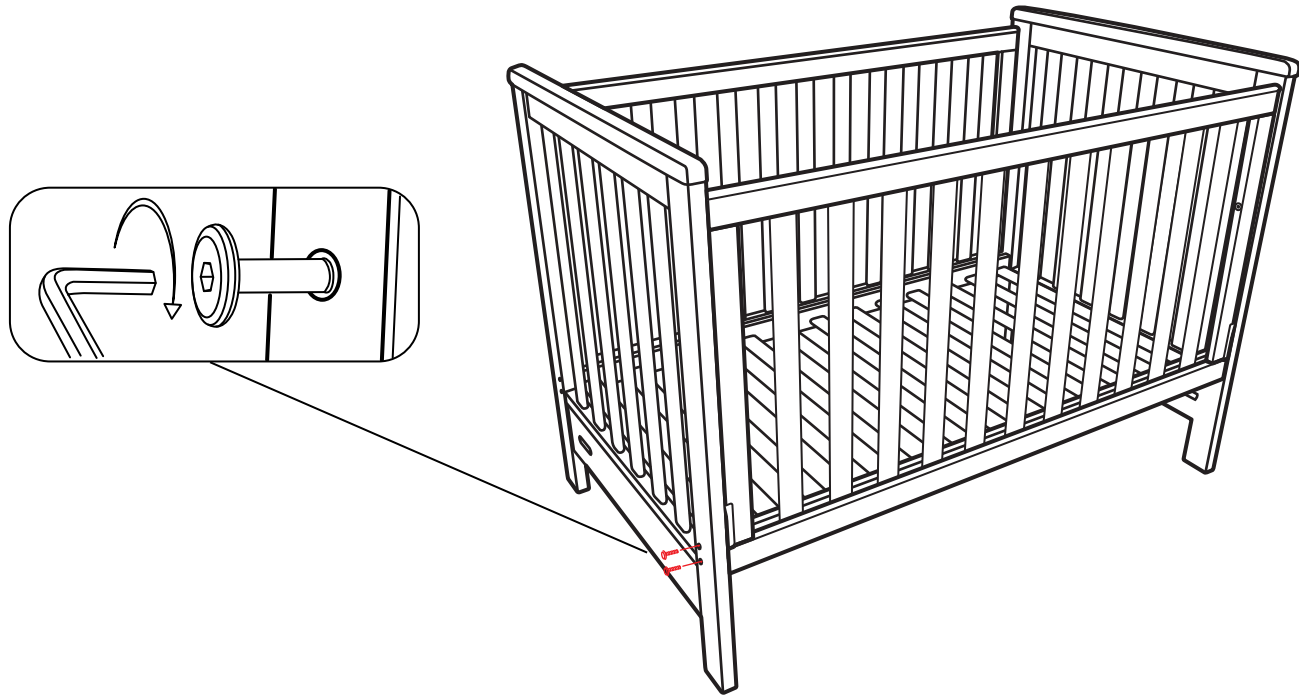

STEP 8

OPERATION

To lower drop side, lift from centre of top rail, hold side in that position while using your leg to push inward on centre of bottom rail. Then allow to slide gently down.

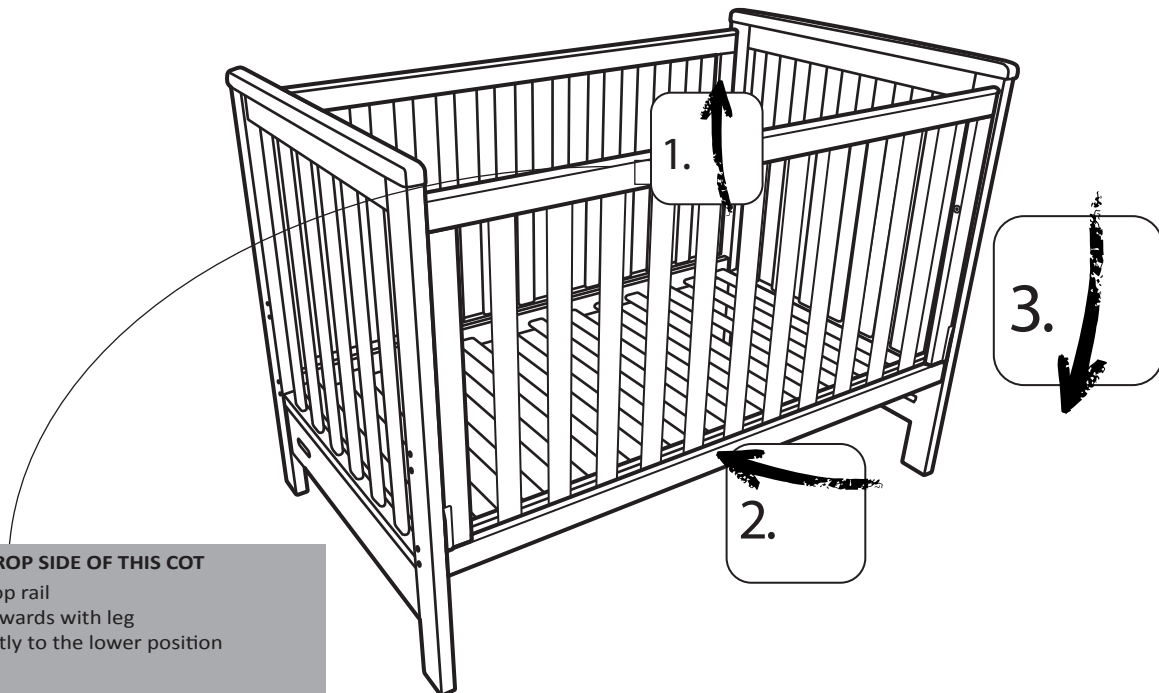

HOW TO OPERATE DROP SIDE OF THIS COT

- 1) Lift side up using top rail
- 2) Push bottom rail inwards with leg
- 3) Lower the side gently to the lower position

To raise side;
Lift side until it 'clicks' into the locked upper position

DAY BED CONVERSION

Remove dropside by reversing to step 4.

! Remove dropside guide pins (HC) from the ends to prevent injury.

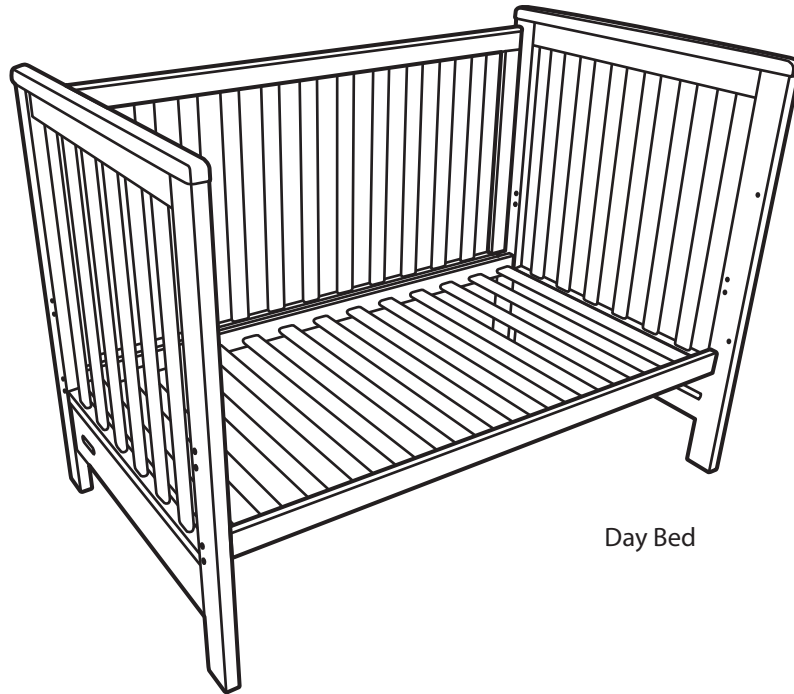

COT BED CONVERSION

a. Remove dropside by reversing to step 4.

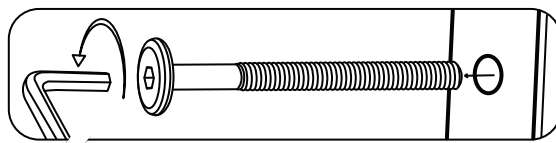

b. Remove fixed side

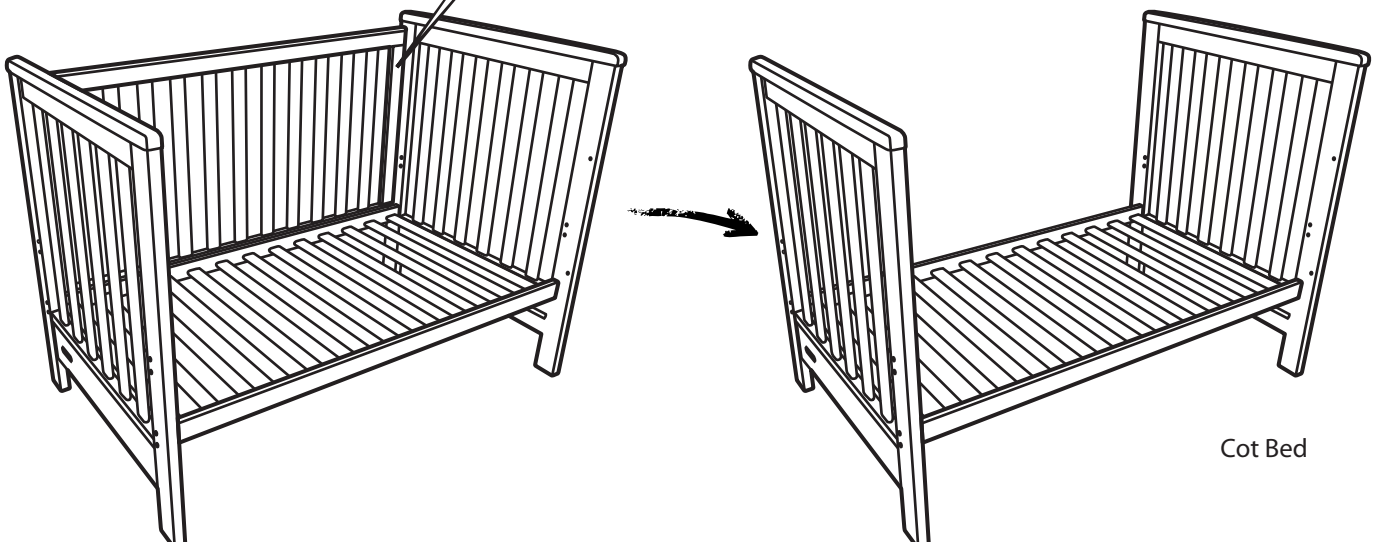

DRAWER ASSEMBLY

STEP 1

INSERT WOOD PINS INTO THE DRAWER SIDES

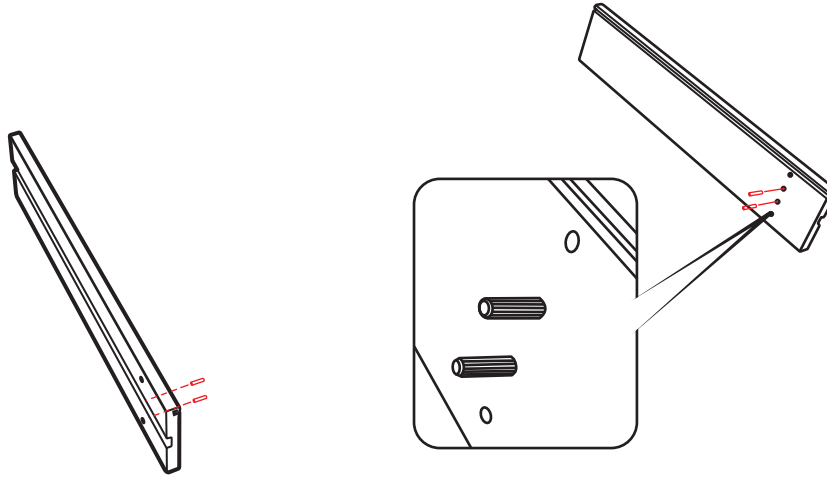
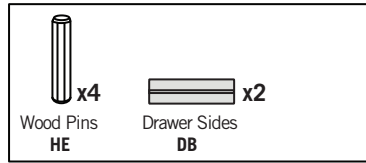

STEP 2

ASSEMBLE THE BACK END TO SIDES

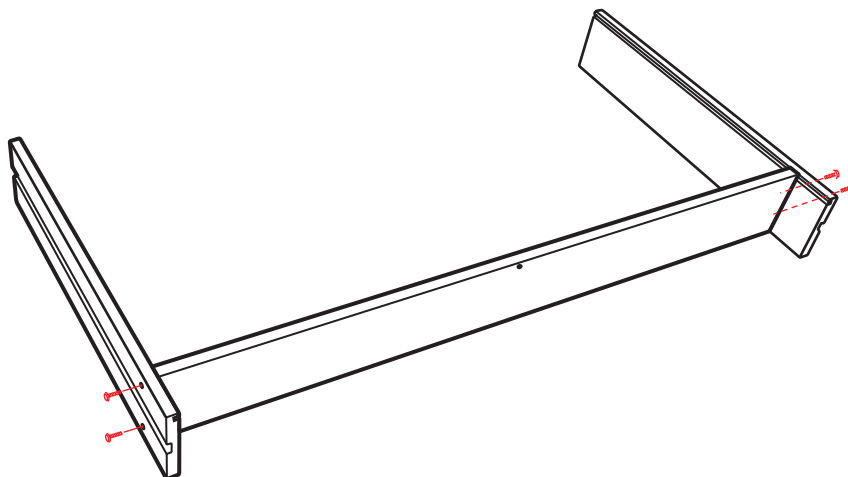
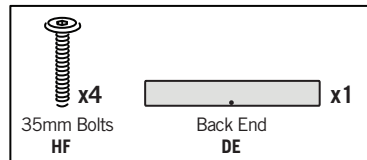

STEP 3

ASSEMBLE THE BOTTOM PLATE HOLDER TO BACK END

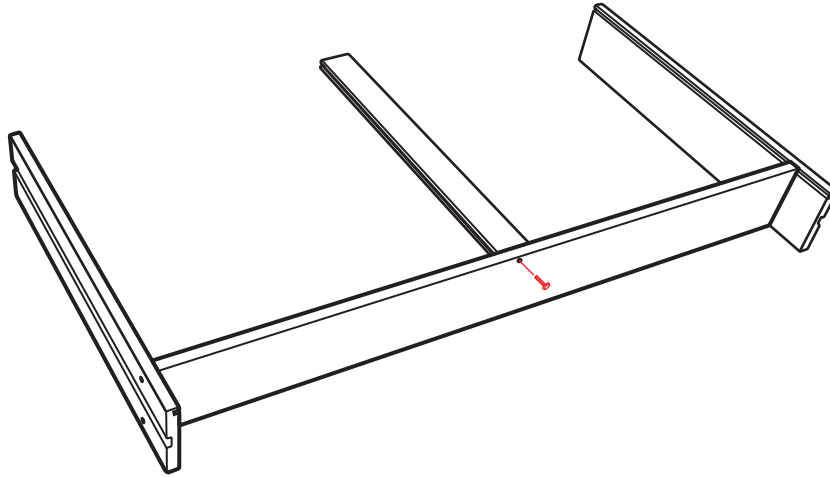
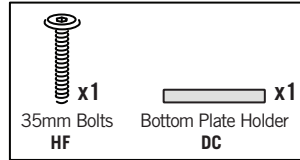

STEP 4

INSERT THE BOTTOM PLATES

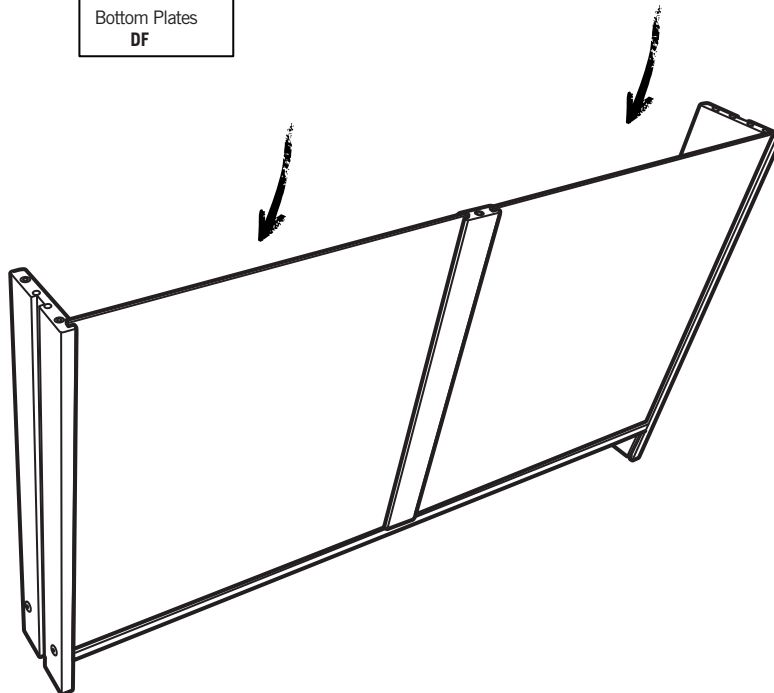
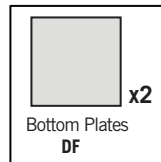

STEP 5

INSERT WOOD PINS INTO THE FRONT END

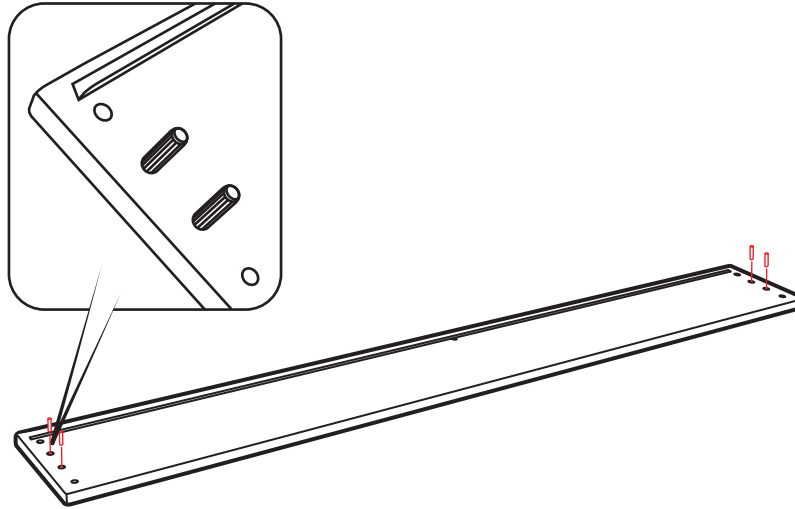
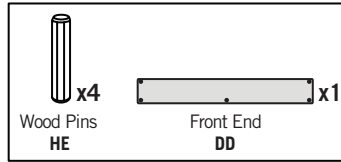

STEP 6

ASSEMBLE THE FRONT END

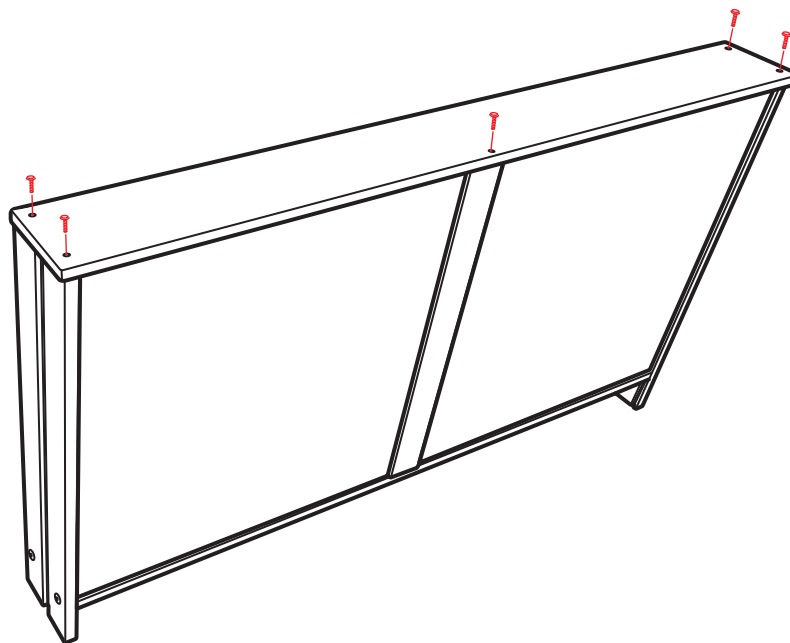
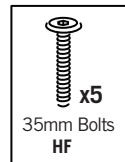

STEP 7

SLIDE THE DRAWER UNDERNEATH THE COT

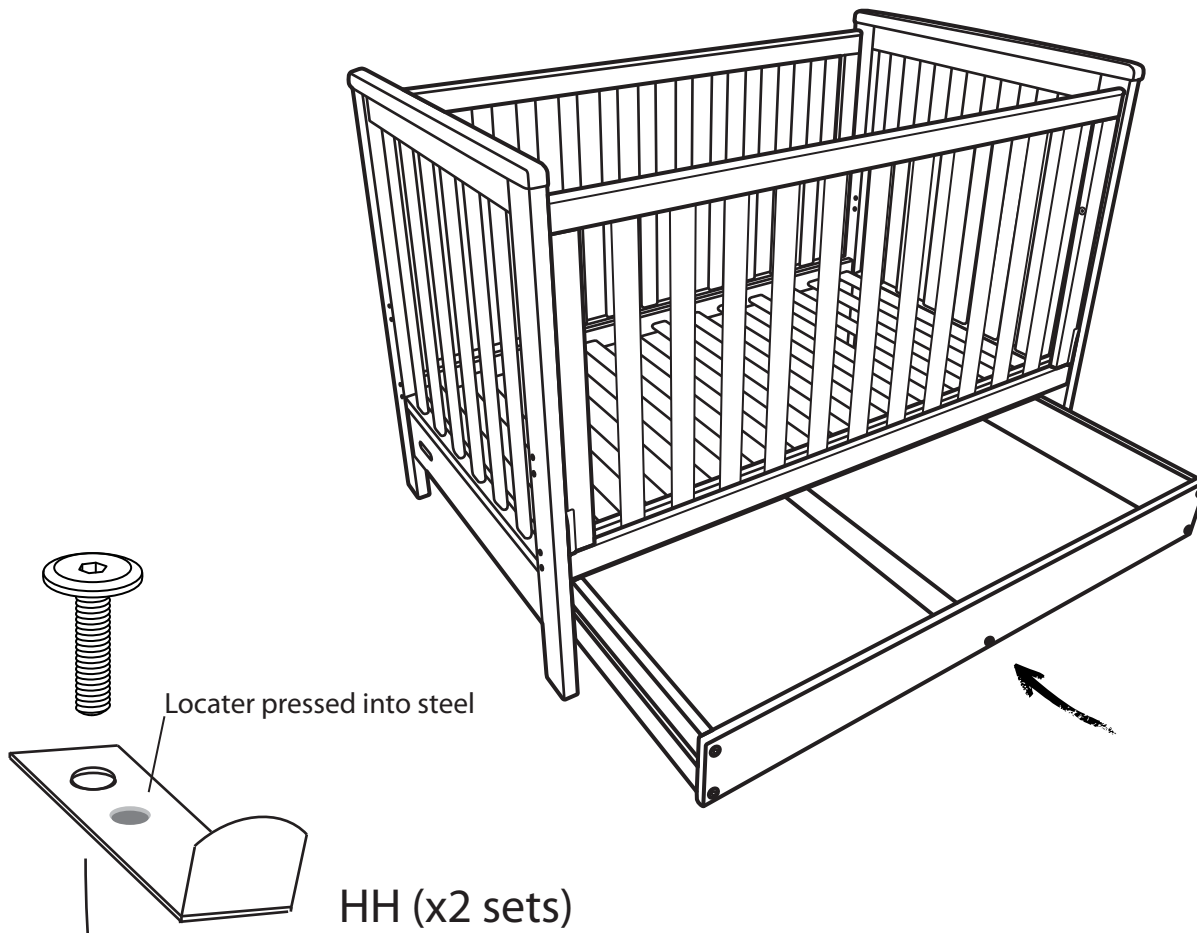

Bolt Drawer Stop Brackets onto drawer sides once drawer is in place. This stops the drawer coming right out. Locater holds bracket in place while tightening bolt



Your cot is now complete.

MAINTENANCE

Check your cot regularly. Retighten all bolts. For after sales service contact Grotime Service Australia on 1300 799 912; or New Zealand on 0508 476 932;

RECOMMENDED MATTRESS SIZE

This cot has been manufactured for use with a mattress which measures 760mm in width and 1300mm in length and 130mm in thickness. The width and length are specified because it is important that the gaps between the mattress and the sides and ends of the cot will not exceed 40mm. This is to minimise the risk of the child's limb becoming caught in the gap. The thickness of the mattress has been specified to ensure that the depth of the cot is greater than 500mm with the mattress base in the lowest position to minimise the risk of a child climbing or falling out of the cot.

5 YEAR NURSERY FURNITURE WARRANTY

1. Our goods come with guarantees that cannot be excluded under the Australian Consumer Law. You are entitled to a replacement or refund for a major failure and for compensation for any other reasonably foreseeable loss or damage. You are also entitled to have the goods repaired or replaced if the goods fail to be of acceptable quality and the failure does not amount to a major failure.
2. In order for your claim to be processed in an efficient timely manner please follow the warranty claims process as out lined below.
 - Fill in the online customer service form found on the following link <http://grotime.net/customer-service-form>
 - If you are unable for any reason to process your warranty claim using the online customer service form please call our Grocorp aftersales service department on toll free 1300 799 912 or email sales@grocorp.net.au
 - In order for your claim to be processed you will need to provide to Grocorp with an original proof of purchase. For example original retailer purchase receipt, bill of sale, invoice, lay-by docket, credit card receipt or similar proof of purchase.
 - Note; providing attached photographs with your claim will greatly enhance the speed in which your claim is processed.
3. This warranty does not obligate Grocorp to bear transportation costs incurred in the repair or replacement of any defective parts and excludes any superficial scratches, dents, scrapes or blemishes to paint work or timber surfaces. This Warranty does not cover faults or defects caused by:
 - Unsuitable, improper use or use not in accordance with the manufactures specifications;
 - Incorrect installation or installation not in accordance with instructions provided;
 - Normal wear and tear;
 - Inadequate or complete lack of maintenance;
 - Chemical, electrochemical or electrical influences; or
 - Harsh detergents or abrasive cleaners used on product finishes.
4. To the fullest extent permitted by law, Grocorp excludes all liability for damage or injury to any person, damage to any property, and any indirect consequential or other loss or damage.

WARNING

TO PREVENT FALLS, THE MATTRESS BASE OF THIS COT SHOULD BE ADJUSTED TO THE LOWEST POSITION BEFORE CHILD CAN SIT UP.

WARNING

ENSURE YOUR CHOSEN LOCATION FOR THE COT IS A REASONABLE DISTANCE FROM CURTAINS, BLINDS, HEATERS, AND POWER POINTS. ALWAYS KEEP MEDICATION, STRING, ELASTIC, SMALL TOYS OR SMALL ITEMS SUCH AS MONEY OUT OF REACH FROM ANY POSITION IN THE COT. BEFORE ASSEMBLING THE COT, ENSURE YOU HAVE A CLEAR AREA ON CARPET OR A THICK BLANKET OR RUG. NEVER ASSEMBLE ON A HARD SURFACE.

CONTACT US

AUSTRALIA - 10 Martini Parade Lithgow NSW 2790
Phone 1300 799 912 Email sales@grocorp.net.au Web www.grotime.net
NEW ZEALAND - 9 Greenacres Road North Richmond, Nelson 7050
Phone 0508 476 932 Email sales@groyears.co.nz Web www.grotime.co.nz