

# KENWOOD

## **Document Copyrights**

Copyright 2006 by Kenwood Corporation. All rights reserved.

No part of this manual may be reproduced, translated, distributed, or transmitted in any form or by any means, electronic, mechanical, photocopying, recording, or otherwise, for any purpose without the prior written permission of Kenwood.

## **Disclaimer**

While every precaution has been taken in the preparation of this manual, Kenwood assumes no responsibility for errors or omissions. Neither is any liability assumed for damages resulting from the use of the information contained herein. Kenwood reserves the right to make changes to any products herein at any time for improvement purposes.

VHF FM TRANSCEIVER

# TK-790/(B)

# TK-790H(B)

## SERVICE MANUAL REVISED

# KENWOOD

© 2001-6 PRINTED IN JAPAN  
B51-8438-10 (N) 1234

This service manual applies to products with 30300001 or subsequent serial numbers. (KCH-10 and KCH-11 are applicable to the productions June 2001 and after.)

In terms of the products with the serial numbers earlier than 30300001, refer to the TK-790/(B)/H(B) service manual as per part No. B51-8438-00 and the TK-790(B) service manual as per part No. B51-8456-00.

### TK-790 or TK-790(B) with KCH-10



### KCH-11



### TK-790H(B)



# TK-790/(B)/H(B)

## CONTENTS / GENERAL

<b>GENERAL</b> .....	<b>2</b>
<b>SYSTEM SET-UP</b> .....	<b>4</b>
<b>OPERATING FEATURES</b> .....	<b>5</b>
<b>INSTALLATION</b> .....	<b>16</b>
<b>DISASSEMBLY FOR REPAIR</b> .....	<b>22</b>
<b>CIRCUIT DESCRIPTION</b> .....	<b>26</b>
<b>SEMICONDUCTOR DATA</b> .....	<b>32</b>
<b>DESCRIPTION OF COMPONENTS</b> .....	<b>36</b>
<b>PARTS LIST</b> .....	<b>39</b>
<b>EXPLODED VIEW</b> .....	<b>57</b>
<b>PACKING</b> .....	<b>61</b>
<b>ADJUSTMENT</b> .....	<b>65</b>
<b>TERMINAL FUNCTION</b> .....	<b>74</b>
<b>WIRING</b> .....	<b>77</b>
<b>PC BOARD VIEWS / CIRCUIT DIAGRAMS</b>	
<b>DISPLAY UNIT (X54-3190-20) : KCH-10</b> .....	<b>79</b>
<b>DISPLAY UNIT (X54-3200-20) : KCH-11</b> .....	<b>81</b>
<b>CONTROL UNIT (X57-5610-XX) (B/3)</b> .....	<b>87</b>
<b>FINAL UNIT (X57-5610-XX) (C/3) : TK-790/(B)</b> .....	<b>97</b>
<b>TX-RX UNIT (X57-5610-XX) (A/3)</b> .....	<b>101</b>
<b>FINAL UNIT (X45-3560-10) : TK-790H(B)</b> .....	<b>113</b>
<b>BLOCK DIAGRAM</b> .....	<b>117</b>
<b>SPECIFICATIONS</b> .....	<b>119</b>

## GENERAL

### INTRODUCTION

#### SCOPE OF THIS MANUAL

This manual is intended for use by experienced technicians familiar with similar types of commercial grade communications equipment. It contains all required service information for the equipment and is current as of this publication date. Changes which may occur after publication are covered by either Service Bulletins or Manual Revisions, which are issued as required.

#### ORDERING REPLACEMENT PARTS

When ordering replacement parts or equipment information, the full part identification number should be included. This applies to all parts : components, kits, and chassis. If the part number is not known, include the chassis or kit number of which it is a part and a sufficient description of the required component, for proper identification.

### PERSONNEL SAFETY

The following precautions are recommended for personnel safety :

- DO NOT transmit if someone is within two feet (0.6 meter) of the antenna.
- DO NOT transmit until all RF connectors are secure and any open connectors are properly terminated.
- SHUT OFF this equipment when near electrical blasting caps or while in an explosive atmosphere.
- All equipment should be properly grounded before power-up for safe operation.
- This equipment should be serviced by only qualified technicians.

## GENERAL

### PRE-INSTALLATION CONSIDERATIONS

#### 1. UNPACKING

Unpack the radio from its shipping container and check for accessory items. If any item is missing, please contact KENWOOD immediately.

#### 2. LICENSING REQUIREMENTS

Federal regulations require a station license for each radio installation (mobile or base) be obtained by the equipment owner. The licensee is responsible for ensuring transmitter power, frequency, and deviation are within the limits permitted by the station license.

Transmitter adjustments may be performed only by a licensed technician holding an FCC first, second or general class commercial radiotelephone operator's license. There is no license required to install or operate the radio.

#### 3. PRE-INSTALLATION CHECKOUT

##### 3-1. Introduction

Each radio is adjusted and tested before shipment. However, it is recommended that receiver and transmitter operation be checked for proper operation before installation.

##### 3-2. Testing

The radio should be tested complete with all cabling and accessories as they will be connected in the final installation. Transmitter frequency, deviation, and power output should be checked, as should receiver sensitivity, squelch operation, and audio output. QT equipment operation should be verified.

#### 4. PLANNING THE INSTALLATION

##### 4-1. General

Inspect the vehicle and determine how and where the radio antenna and accessories will be mounted.

Plan cable runs for protection against pinching or crushing wiring, and radio installation to prevent overheating.

##### 4-2. Antenna

The favored location for an antenna is in the center of a large, flat conductive area, usually at the roof center. The trunk lid is preferred, bond the trunk lid and vehicle chassis using ground straps to ensure the lid is at chassis ground.

#### 4-3. Radio

The universal mount bracket allows the radio to be mounted in a variety of ways. Be sure the mounting surface is adequate to support the radio's weight. Allow sufficient space around the radio for air cooling. Position the radio close enough to the vehicle operator to permit easy access to the controls when driving.

#### 4-4. DC Power and wiring

1. This radio may be installed in negative ground electrical systems only. Reverse polarity will cause the cable fuse to blow. Check the vehicle ground polarity before installation to prevent wasted time and effort.
2. Connect the positive power lead directly to the vehicle battery positive terminal. Connecting the Positive lead to any other positive voltage source in the vehicle is not recommended.
3. The cable provided with the radio is sufficient to handle the maximum radio current demand. If the cable must be extended, be sure the additional wire is sufficient for the current to be carried and length of the added lead.

#### 5. INSTALLATION PLANNING – CONTROL STATIONS

##### 5-1. Antenna system

Control station. The antenna system selection depends on many factors and is beyond the scope of this manual. Your KENWOOD dealer can help you select an antenna system that will best serve your particular needs.

##### 5-2. Radio location

Select a convenient location for your control station radio which is as close as practical to the antenna cable entry point. Secondly, use your system's power supply (which supplies the voltage and current required for your system). Make sure sufficient air can flow around the radio and power supply to allow adequate cooling.

### SERVICE

This radio is designed for easy servicing. Refer to the schematic diagrams, printed circuit board views, and alignment procedures contained in this manual.

# TK-790/(B)/H(B)

## SYSTEM SET-UP

### Before Reading About System Set-up

The TK-790(B)/H(B) is a transceiver main unit (without a panel or speaker) that you complete by adding options.

The options are classified into three types according to operation and function.

1. Install the front panel kit (controller) directly on a radio to operate it. (Form : Radio + KCH-10/11)
2. Remotely control one radio with one controller. (Form : Radio + KRK-5 + KCH-10/11 + KCT-22M/M2/M3)

3. Remotely control one radio with two controllers. (Form : Radio + KRK-6DH + KCH-10/11 (two) + KCT-22M/M2/M3 (two))
4. Remotely control two radios with one controller. (Form : Radios (two) + KRK-7DB + KCH-10/11 + KCT-22M/M2/M3)
5. Remotely control two radios with two controllers. (Form : Radio (two) + KRK-8DBH + KCH-10/11 (two) + KCT-22M/M2/M3 (two))

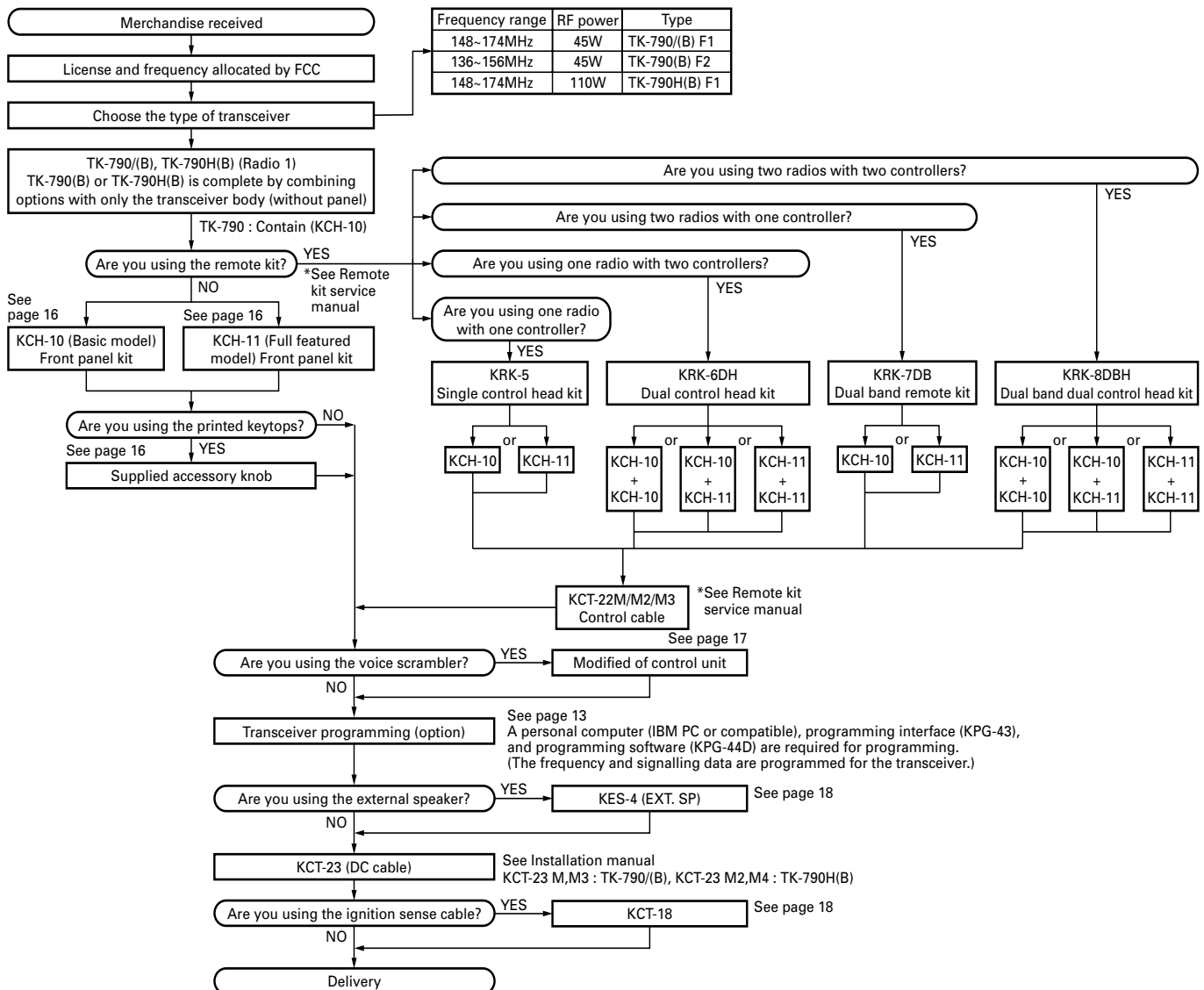

\*Service manual parts No. list

Model	Parts No.
KRK-5/6DH	B51-8445-00
KRK-7DB/8DBH	B51-8452-00

## OPERATING FEATURES

### 1. Controls and Functions

#### 1-1. Basic Function Panel

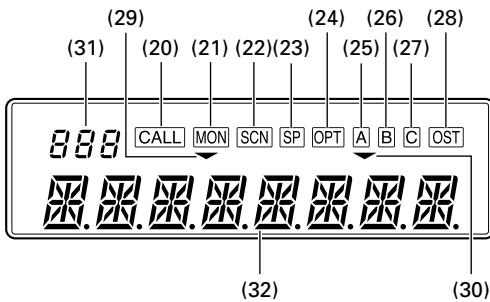
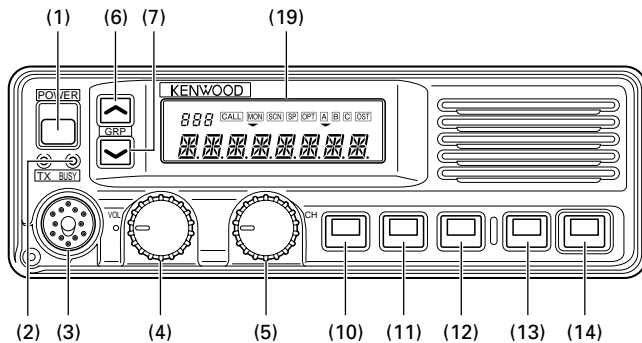

#### 1-2. Full Function Panel

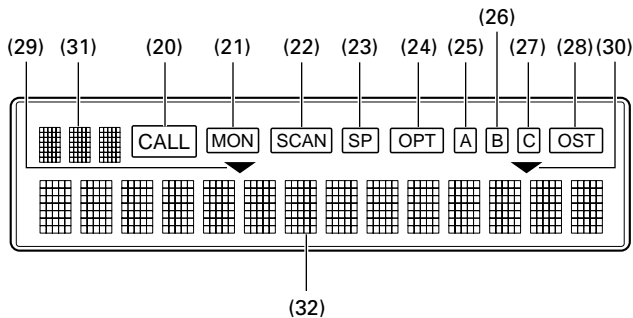
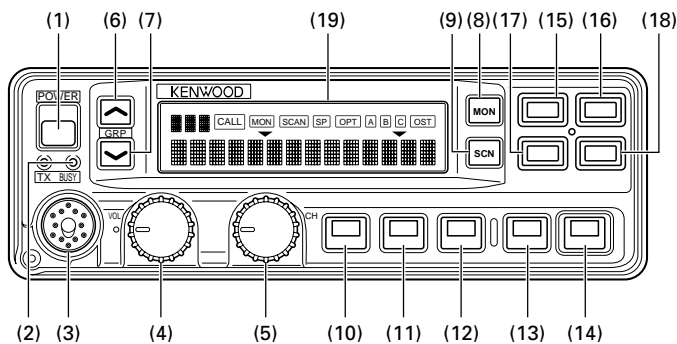

- (1) POWER Switch  
Press to turn the power ON and OFF.
- (2) TX/BUSY Indicator  
The TX Indicator (Red LED) shows that you are transmitting.  
The BUSY Indicator (Green LED) shows that the channel is in use.
- (3) Microphone Connector
- (4) Volume Knob  
To increase the volume level, turn clockwise (CW).  
To decrease the volume level, turn counterclockwise (CCW).
- (5) UP/DOWN Knob  
The function of this Knob can be programmed by the FPU.

Function	Description	Note
Channel UP/DOWN	Channel selector. To increase the channel, turn CW. To decrease the channel, turn CCW.	Default setting.
Group UP/DOWN	Group selector. To increase the group, turn CW. To decrease the group, turn CCW.	

- (6) GR UP Key, (7) GR DW Key, (8) MON Key, (9) SCN Key, (10)~(18) PF1-9 Key  
The function of these Keys can be programmed by the FPU.

Function	Description	Note
[ ] : Key top name		
No Function	No function.	Default setting of PF1~9.
Monitor [MON]	If [MON] is pressed once while the RADIO is waiting for reception, all signalling* squelch is canceled. If [MON] is held down for 2 seconds, noise squelch is canceled and the audio is unmuted.	Default setting of MON. (Full function panel) all signalling; QT/DQT & 2 TONE/DTMF
Scan [SCN]	Start and stop the scanning sequence.	Default setting of SCN. (Full function panel)
Public Address [PA]	The RADIO works as a PUBLIC ADDRESS amplifier.	
Horn Alert [HA]	When the RADIO receives a the optional signalling calls that are assigned to the channel, the HA relay turns on.	
Talk Around [TA]	Use this function to communicate with other operators directry, without using a repeater.	
Intercom [IC]	Use this function to communicate between the HEAD1 and HEAD2 operator without transmitting.	Dual HEAD configuration only.

## OPERATING FEATURES

Function [ ] : Key top name	Description	Note
Channel Name [AN]	Switches the display between Group-Channel No. and Group channel name.	
Speaker Internal/ External [SP]	Switch the audio output between Internal speaker and PA speaker.	
Delete/ Add [D/A]	Changes the Scan DELETE/ADD setting of each channel or group.	Press and hold [D/A] for more than 2 seconds to toggle a Group DEL and ADD.
Squelch Level [SQL]	Press to enter Squelch Level Adjust Mode. The Squelch level can be adjusted by using the UP/DOWN Knob, or the preprogrammed channel Up/Down key or Group Up/Down key.	
Operator Selectable Tone [OST]	Select signalling from the pre-programmed QT/DQT list.	
Scrambler [OPT]	The optional board on and off.	Install the Scrambler board.
AUX A [AUXA]	Turns AUX A port on and off.	
AUX B [AUXB]	Turns AUX B port on and off.	
AUX C [AUXC]	Turns AUX C port on and off.	
Home Channel (Fixed) [HC]	Switches to the pre-programmed Home Channel.	
Home Channel (Toggle) [HC]	When pressed once, switches to the Home Channel. Press again to returns to the previous channel.	
CH1 Direct [CH1]	Switches to the GR1-CH1 directry.	
CH2 Direct [CH2]	Switches to the GR1-CH2 directry.	
CH3 Direct [CH3]	Switches to the GR1-CH3 directry.	
CH4 Direct [CH4]	Switches to the GR1-CH4 directry.	
CH5 Direct [CH5]	Switches to the GR1-CH5 directry.	
Channel Recall [RCL]	When pressed once, switches to the last called channel. Press again to return to the previous channel.	The [RCL] Key works in Scan Mode only.
Dimmer [DIM]	Use this function to adjust the LCD backlight brightness, Key backlight, TX/BUSY LED, and DTMF Mic Key backlight ON/OFF.	

Function [ ] : Key top name	Description	Note
Speaker 1-2 Mute [SPM]	Each speaker audio can be manually disabled from the other control head.	Dual HEAD configuration only.
Channel UP [ ^ ]	If [ ^ ] is pressed once, the channel increases by one step. If [ ^ ] is held down for 1 second, the channel increases continuously.	
Channel DOWN [ v ]	If [ v ] is pressed once, the channel decreases by one step. If [ v ] is held down for 1 second, the channel decreases continuously.	
Group UP [ ^ ]	If [ ^ ] is pressed once, the group increases by one step. If [ ^ ] is held down for 1 second, the group increases continuously.	
Group DOWN [ v ]	If [ v ] is pressed once, the group decreases by one step. If [ v ] is held down for 1 second, the group decreases continuously.	
Mobile Relay Station [RPT]	The RADIO works as a repeater.	Dual BAND configuration only.
Emergency Call [EMG]	To start an Emergency Call, press [EMG].	This function needs the ANI board.

### (19) LCD Display

	Description	Note
(20) CALL	Flashes when the RADIO is called by proper Optional Signalling (DTMF or 2Tone).	If Signalling has been set "AND", CALL lights after transmitting.
(21) MON	Lights when [MON] is pressed. Signalling squelch is disabled.	
(22) SCN	Indicates when scan mode is enabled.	
(23) SP	Lights when "PA speaker" is selected for audio output.	
(24) OPT	Lights when the optional board*, that is installed inside the RADIO, is enabled.	Optional Board : - Scrambler
(25) A	Lights when [AUXA] is pressed. The PF Port that is programmed with "AUX A" is ON.	
(26) B	Lights when [AUXB] is pressed. The PF Port that is programmed with "AUX B" is ON.	

## OPERATING FEATURES

	Description	Note
(27) C	Lights when [AUXC] is pressed. The PF Port that is programmed with "AUX C" is ON.	
(28) OST	Lights when [OST] is pressed, Operator Selectable Tone is enabled.	
(29) ▼ (Group Add Status)	If the selected group is in the multi group scan sequence, the indicator appears at the group.	
(30) ▼ (Channel Add Status)	If the selected channel is in the scan sequence, the indicator appears at the channel.	
(31) • BASIC FUNCTION PANEL 7 SEGMENT display • FULL FUNCTION PANEL DOT MATRIX (S) display	Displays the channel status. P1 : Lights when a PRIORITY 1 channel is shown on the display. P2 : Lights when a PRIORITY 2 channel is shown on the display. PP : Lights when a PRIORITY 1 & 2 channel is shown on the display. HC : Lights when a Home Channel is selected by [HC] key. TA : Lights when the RADIO is in Talk Around mode. RCL : Lights when recall channel is selected by [RCL] key. R1-R15 : Lights when remote channel is selected by PF port.	
(32) • BASIC FUNCTION PANEL 13 SEGMENT display • FULL FUNCTION PANEL DOT MATRIX (L) display	Displays the operating Group-Channel number (Channel display), or name (Alphanumeric display) programmed by the FPU. Also displays the status of some features.	

### 1-3. Microphone

Press PTT (Push To Talk) to transmit, then speak into the microphone.

### 2. Receive

- (1) To turn on the RADIO:  
Press the Power Switch. The display and graphics illuminate to indicate the RADIO is ON.
- (2) To adjust the volume level:  
Turn the Volume Knob CW to increase the volume level.  
Turn the Volume Knob CCW to decrease the volume level.
- (3) To select a Group:  
Select a Group by rotating the UP/DOWN Knob which has been programmed with "Group UP/DOWN" or by pressing the Keys which have been programmed with "Group UP" and "Group DOWN".  
If the "Channel Tracking Function" is enabled, the channel number will not change.
- (4) To Select a Channel:  
Select a Channel by rotating the UP/DOWN Knob which has been programmed with "Channel UP/DOWN" or by pressing the keys which have been programmed with "Channel UP" and "Channel DOWN".
- (5) To enter carrier squelch mode:  
If you want to monitor a channel, press [MON] Key. If the "OFF HOOK Decode" function has been disabled, you can also enter monitor mode by taking the microphone off HOOK.

### 3. Transmit

- (1) Normal ON HOOK Scan Mode  
First, lift the microphone from the HOOK. The scanning stops temporarily and the OFF HOOK revert channel is displayed. Listen for a few seconds to make certain the channel is not being used.  
OFF HOOK Scan MODE  
If scanning, pressing the PTT switch will stop the RADIO on the OFF HOOK revert channel and begin transmission immediately.  
Not Scan Mode  
Pressing PTT starts transmission at the selected channel.
- (2) Press PTT and start speaking. For best results, hold the microphone 1 to 1.5 inches from your mouth. Release PTT when your message is complete. Listen for a response.
- (3) When your conversation is finished, replace the microphone on its hook.

### 4. Scan Operation

#### 4-1. General

There are two "Mic HOOK" scan modes in which the RADIO can be programmed to operate.

- ON HOOK Scan  
Normal method of scanning that requires the microphone to be ON HOOK (hanged on the Mic Hanger) to initiate scan.
- OFF HOOK Scan  
The microphone does not have to be ON HOOK to initiate scan or to scan channels.

## OPERATING FEATURES

- (1) The scan feature is initiated by pressing the [SCN] Key.
- (2) A single confirmation tone sounds, and scanning starts. If there is only one or no added channels, an error tone will sound and scanning will not start.
- (3) The display shows "SCN" icon, and "SCAN" or the OFF HOOK Revert Channel Number (FPU setting).
- (4) If the RADIO receives a proper signal while scanning, scanning stops temporarily, audio is unmuted, and the channel number or name is displayed.  
If either "Priority1" or "Priority2" is programmed and scanning stops at a Normal Channel by receiving a signal, the RADIO watches for a signal on the Priority Channel periodically. When a signal exists on the Priority Channel, the channel will change from the Normal Channel to Priority Channel.  
If both "Priority1" and "Priority2" are programmed and scanning stops at the Priority2 Channel by receiving a signal, the RADIO watches a signal on the Priority1 Channel periodically. When a signal exists on the Priority1 Channel, the channel will change from the Priority2 Channel to the Priority1 Channel.  
If there is no Priority Channel programmed, the scanning stops at a channel and receives only that channel.
- (5) If the [SCN] Key pressed again, Scan Mode ends at the revert channel, and two confirmation tones sound.

### 4-2. To Delete Undesired Channels

To temporarily delete undesirable channels, press [D/A] Key while the channel is displayed, and scanning resumes. (To temporarily delete Priority Channel 1 or 2, set the "Priority Temporary D/A" function to "YES".)

You can't delete a channel in Scan Mode under the following conditions:

- Priority Scan  
There is only channel beside the Priority Channel in the scan sequence.
- Non-priority Scan  
There are only 2 channels in the scan sequence. To restore the original scan sequence, either turn scan off and on or turn the RADIO off and on.

### 4-3. To Enter Carrier Squelch Scan While Scan is On

If you have pressed the [MON] Key, the MON indicator is turned on and the RADIO operates in carrier squelch scan.

## 5. Adding Channels and Groups to the Scan Sequence

- (1) Channels  
To add the currently displayed channel to the scan sequence, press [D/A] Key. The CH ADD indicator (▼) lights, and the channel is added to the scan sequence.
- (2) Groups  
To add the currently displayed group of channels to the scan sequence, hold down the [D/A] Key for 2 seconds. The GR ADD indicator (▼) lights, and the group is added to the scan sequence.

## 6. Deleting Channels and Groups from the Scan Sequence

- (1) Channels  
To delete a channel from the scan sequence press [D/A] Key. The CH ADD indicator (▼) goes off, and the channel is deleted from the scan sequence.
- (2) Groups  
To delete the currently displayed group of channels from the scan sequence, hold down [D/A] Key for 2 seconds. The GR ADD indicator (▼) goes off, and all the channels in the group are deleted from the multi group scan sequence.

## 7. Operator Selectable Priority

- (1) Operator Selectable Priority1  
If Priority1 has been set to "Operator Selectable", you can set the currently displayed channel as Priority1. To set the currently displayed channel as Priority1, hold down the [SCN] Key and press the [MON] Key three times.
- (2) Operator Selectable Priority2  
If Priority2 has been set to "Operator Selectable" you can set the currently displayed channel as Priority2. To set the currently displayed channel as Priority2, hold down the [SCN] Key and press the [MON] Key twice.

## 8. Talk Around (TA)

Talk Around is useful when you are close to other mobiles you want to talk to, or are outside the range of your repeater system.

Press the [TA] Key. A confirmation tone sounds, and "TA" (BASIC Panel : 7 segment, FULL Panel : DOT MATRIX (S)) is displayed. You can communicate without using a repeater.

To use a repeater, press [TA] again. A confirmation tone sounds, and "TA" goes off.

## 9. Horn Alert (HA)

If you are called from the base station using 2Tone/DTMF while you are away from your transceiver, you will be alerted by the vehicle horn or some other type of external alert. To turn the horn alert function on, press the [HA] Key. A confirmation tone sounds, and the display shows HORN ALERT (or HA).

If [HA] is pressed again, the horn alert function is turned off.

## OPERATING FEATURES

### 10. Public Address (PA)

Public Address amplifies the microphone audio, and outputs it through a PA speaker. PA is activated by pressing the [PA] Key. A confirmation tone sounds, and the display shows PUBLIC ADDRESS (or PA). PA can be activated at anytime (scanning or non-scanning).

The RADIO continues to scan & receive calls while in PA mode. Pressing PTT activates PA, and will override an incoming call at anytime ; however, no RADIO transmission takes place. If [PA] is pressed again, a confirmation tone will sound, the display will return to the normal channel or SCAN display, and the PA function will turn off.

### 11. Speaker Internal/External (SP)

SP amplifies the received audio from the RADIO and outputs it through a PA speaker. SP is activated by pressing the [SP] Key. A confirmation tone sounds and the SP icon is displayed. SP can be activated at anytime (scanning or non-scanning).

The RADIO transmits and operates normally while SP is activated, but all received calls will be output through the PA speaker. If [SP] is pressed again, a confirmation tone sounds, the SP icon goes off and the SP function will turn off.

### 12. Channel Name (AN)

This function switches the 13-segment display (BASIC Panel) or DOT MATRIX (L) display (FULL Panel) between alphanumeric and Group-Channel number.

If you want to change from alphanumeric display to channel display, press [AN] Key. A confirmation tone sounds, and the alphanumeric display changes to the channel display.

If [AN] is pressed again, a confirmation tone sounds, and the channel display changes back to the alphanumeric display.

### 13. Intercom (IC) ; Dual Head Configuration only

Intercom (IC) allows one control head operator to talk to the another control head operator. IC mode is activated by pressing the [IC] Key. A confirmation tone sounds and the display shows INTERCOM. IC can be activated at anytime (scanning or non-scanning).

The RADIO continues to scan & receive calls while in IC mode. Pressing PTT activates IC and will override an incoming call at anytime ; however, no RADIO transmission takes place. If [IC] is pressed again, a confirmation tone sounds, the display returns to the normal channel or SCAN display, and the IC function will turn off.

### 14. Home Channel (HC)

This feature allows the radio operator to immediately select a pre-determined "Home Channel" by pressing the [HC] Key. HC can be activated as follows.

	CASE1 : HC has been set as "HC (Fixed)"		
	Non-Scan Mode	Scanning	Scan temporary stopping
press [HC] once	Change to Home Channel		
press [HC] again	No effect		
	CASE2 : HC has been set as "HC (Toggle)"		
	Non-Scan Mode	Scanning	Scan temporary stopping
press [HC] once	Change to Home Channel		
press [HC] again	Return to current channel	Change to Revert Channel	Return to current channel

### 15. Squelch Level (SQL)

This function allows the radio operator to manually adjust the squelch threshold in 16 steps (Level 0~15) via the front panel controls. To adjust the squelch level:

- (1) Press the [SQL] Key. A confirmation tone sounds, and the RADIO enters Squelch Level Adjust Mode. In this mode, all signalings are canceled and audio is unmuted. The display shows SQUELCH XX (or SQL XX). (XX= squelch level)
- (2) Change the squelch level by pressing [ ^ ] and [ v ] Keys, or rotating the UP/DOWN Knob.
- (3) Press [SQL] again. A confirmation tone sounds, the display returns to the normal channel, the level setting is memorized, and Squelch Level Adjust Mode will turn off.

\* This feature can be initiated when the RADIO is not in scanning mode.

### 16. Operator Selectable Tone (OST)

This function allows the radio operator to change the pre-set decode QT/DQT, encode QT/DQT. You can select Dec/Enc OFF or from up to 16 decode/encode pairs (Pair No. 1~16) programmed by the FPU. To select the Dec/Enc pairs:

- (1) Press the [OST] Key. A confirmation tone sounds, and the display shows the OST Name which is memorized in the channel for 2 seconds. The "OST" icon lights, and OST is enabled.  
Press [OST] again, and the OST icon goes off and OST is disabled.
- (2) When the [OST] Key is held down, a confirmation tone sounds and the RADIO enters OST Select Mode.
- (3) Select the Dec/Enc pair by pressing the [ ^ ] and [ v ] Keys, or rotating the UP/DOWN Knob. The display shows TONE XX (XX=Dec/Enc pair number) or the OST Name.
- (4) Press [OST] again, a confirmation tone sounds, the display returns to the normal channel, the pair is memorized and OST Mode will turn off.

\* You can select a Dec/Enc pair on each channel.

# TK-790/(B)/H(B)

## OPERATING FEATURES

### 17. Option Board (OPT)

If an optional Scrambler board has been installed in the RADIO, Scrambler is activated by pressing the [OPT] Key. A confirmation tone sounds, and the OPT icon is displayed. If [OPT] is pressed again, a confirmation tone sounds, the OPT icon goes off and the Scrambler will turn off.

If [OPT] is held down, the RADIO enters SCR Code Set Mode. A confirmation tone sounds, and the display shows CODE XX (XX=SCR Code). Change the SCR Code by pressing the [^] and [v] Keys, or rotating the UP/DOWN Knob.

Press [OPT] again, a confirmation tone sounds, the display returns to channel (SCR is ON), the SCR Code setting is memorized, then SCR Code Set Mode will turn off.

### 18. AUX A, AUX B, AUX C

This function switches the accessory PF Output ports which have been programmed with AUX A, AUX B and AUX C.

Press [AUXA] Key. A confirmation tone sounds, the A icon is displayed, and the AUX A Port is switched on (Low level). If [AUXA] is pressed again, a confirmation tone sounds, the A icon goes off and the AUX A Port is switched off (open collector).

In the same way, [AUXB] Key controls the AUX B Port, and [AUXC] Key controls the AUX C Port.

### 19. Direct Channel Access

This feature allows the radio operator to immediately select CHANNELS 1~5 which are contained in GROUP 1. To select GR1-CH1, press [CH1]. To select GR1-CH2~5, press [CH2] ~ [CH5],

### 20. Channel Recall (RCL)

This feature is enabled in scan mode.

This feature allows the radio operator to immediately access the last called (Unmuted) channel by pressing [RCL]. The 3-digit display shows "RCL". Press [RCL] again, and the radio returns to the previous channel.

### 21. Dimmer (DIM)

To adjust the brightness of the display backlight, TX/BUSY LED, panel Keys backlight and microphone keys backlight, press the [DIM] Key.

[DIM] controls the brightness at the same time as follows.

	Display backlight	TX/BUSY LED	Panel Keys backlight	Microphone Keys backlight
Default	High	High	High	High
Press [DIM] once	Medium	↓	↓	↓
Press again	Low	↓	↓	↓
Press again	OFF	OFF	OFF	OFF
Press again	return to High	return to High	return to High	return to High

\* The brightness setting is memorized.

### 22. Speaker 1-2 Mute (SPM)

#### ; Dual Head Configuration only

This feature allows the radio operator to manually disable the speaker audio of another control head.

Press the [SPM] Key, a confirmation tone sounds, and the other head speaker is muted. Both head displays shows X MUTE (X=Muted HEAD number).

This muted condition is canceled by both head keys without PTT and Mic HOOK which is connected to Un-muted head.

### 23. Mobile Relay Station (RPT)

#### ; DUAL BAND Configuration only

This function allows the radio operator to use the RADIO as a repeater.

- (1) Both "Repeater Channel 1" and "Repeater Channel 2" must be pre-programmed by the FPU. Each channels must be on different bands.
- (2) Press the [RPT] Key, then both the VHF and UHF units move to the repeater channel, and enter Repeater mode. Displays of both heads show "REPEATER".
- (3) If one unit receives a proper signal, the other unit will start transmitting (repeating).
- (4) If the signal stops, the repeat action will stop. If one of the units detects another signal, the repeat action will restart.
- (5) Press [RPT] again, both units return to their previous channels, and exit the Repeater mode. However, during the repeating mode, pressing [RPT] has no effect.

### 24. Emergency Call (EMG)

If the [EMG] Key is held down, the RADIO enters the Emergency Mode. In the Emergency Mode, the channel changes to the "Emergency Channel (set by the FPU)" internally. The display depends on "Emergency Channel Display" setting, and the Emergency Call (None, DTMF, MSK or ANI board) is transmitted.

If "ANI Board" is selected for the Emergency Type, turn the transceiver off, then turn it on again to recover "Normal Mode".

If "ANI Board" is not selected for the Emergency Type, press and hold [EMG] key to recover "Normal Mode".

## OPERATING FEATURES

### 25. Busy Channel Lockout (BCL), BCL Override

The Busy Channel Lockout function prevents interference with other stations that may be using the same channel.

While the selected channel is in use, pressing PTT causes the RADIO to sound a warning tone, and transmission is inhibited. To stop the warning tone, release PTT.

If BCL Override has been enabled, pressing PTT within 500msec again will cancel BCL, and transmission is enabled.

### 26. 2Tone Signalling

2Tone signalling opens the squelch only when the RADIO receives a proper 2Tone code that is the same as the pre-programmed 2Tone for the channel. When the RADIO receives a 2Tone code, the CALL icon flashes.

If Transpond has been programmed, the RADIO will return an acknowledgment signal automatically after receiving the 2Tone code.

If Call Alert has been programmed, an Alert Tone sounds after receiving a 2Tone code. You can configure "Normal" (an alert tone beeps once) or "Continuous" (an alert tone beeps every 5 seconds) for the Call Alert. Unmute condition is canceled and the CALL icon goes off when ; (1) pressing the [MON] Key, (2) hanging the microphone on its hook, (3) muting continues for 10 seconds. (If "Auto Reset" has been programmed)

### 27. DTMF Signalling

DTMF Signalling opens the squelch only when the RADIO receives a proper DTMF code that is the same as the pre-programmed "Primary Code (Individual ; 1~7digits)" or "Secondary Code (Group ; 1~7digits)". When the RADIO receives a correct code, the CALL icon flashes.

If Transpond has been programmed, the RADIO will return an acknowledgment signal automatically after receiving the DTMF code.

If Call Alert has been programmed, an Alert Tone sounds after receiving a DTMF code. You can configure "Normal" (an alert tone beeps once) or "Continuous" (an alert tone beeps every 5 seconds) for the Call Alert. Unmute condition is canceled and the CALL icon goes off when ; (1) pressing the [MON] Key, (2) hanging the microphone on its hook, (3) muting continues for 10 seconds (If "Auto Reset" has been programmed), and (4) receiving reset code. (Primary code + "#" or secondary code + "#")

### 28. Time Out Timer

#### (Possible to configure to each group)

The Time Out Timer function interrupts continuous transmission after a specified time elapses.

Holding down PTT for longer than the programmed time causes the RADIO to stop transmitting and sound a warning tone. To stop the warning tone, release PTT.

### 29. Signalling AND/OR

#### (Possible to configure to each group)

The RADIO will be unmuted with a combination of QT/DQT and 2Tone/DTMF. The AND/OR setting works as follows.

#### 29-1. AND

The audio is unmuted when the RADIO receives the correct QT/DQT and 2Tone/DTMF. After transmitting, 2Tone/DTMF will be canceled.

#### 29-2. OR

The audio is unmuted when the RADIO receives the correct QT/DQT. 2Tone/DTMF is used just as an individual call or group call.

### 30. Off Hook Decode

If the OFF HOOK Decode function has been enabled, removing and replacing the microphone on the HOOK has no effect for decoding QT/DQT and 2Tone/DTMF.

### 31. TX Audio Monitor

#### ; Dual Head Configuration only

This function allows the radio operator to hear another operator's voice which is transmitted through another control head.

If the TX Audio Monitor function is set to "w/Talk Interrupt" and one operator is transmitting, the other operator's control head displays "INTERCOM" and he/she can speak to the transmitting control head by pressing PTT.

### 32. Roll Over/Dead End

#### 32-1. Roll Over

When [ ^ ] (CH UP) is pressed, or the CH UP/DOWN Knob is turned CW from the Maximum channel, the channel changes to the Minimum channel.

When [ v ] (CH DOWN) is pressed, or the CH UP/DOWN Knob is turned CCW from the Minimum channel, the channel changes to the Maximum channel.

#### 32-2. Dead End

When [ ^ ] (GR UP) is pressed, or the GR UP/DOWN Knob is turned CW from the Maximum group, the group doesn't change.

When [ ^ ] (CH UP) is pressed, or the CH UP/DOWN Knob is turned CW from the Maximum channel, the channel doesn't change.

When [ v ] (GR DOWN) is pressed, or the GR UP/DOWN Knob is turned CCW from the Minimum group, the group doesn't change.

When [ v ] (CH DOWN) is pressed, or the CH UP/DOWN Knob is turned CCW from the Minimum channel, the channel doesn't change.

## OPERATING FEATURES

### 33. Minimum Volume

When the Volume Knob is adjusted fully counterclockwise, the audio level is set to the Minimum Volume level which is programmed by the FPU.

### 34. Dead Beat Disable (DBD)

If the RADIO receives a DBD Code (1~7digits), the RADIO returns an acknowledgment signal automatically, and transmission is disabled. This TX INHIBIT condition is memorized.

If the RADIO receives a DBD Reset Code (DBD Code + #), the RADIO returns an acknowledgment signal automatically, and transmission is Enabled.

### 35. ANI Board

The ANI board contains functions which you can use. To use the function, you select that function on the ANI board.

### 36. Accessory Programmable Function Port (PF Port)

The RADIO has 13 PF Ports.

HEAD (12 pin) : PF Input Port 2, PF Output Port 2

DECK (Dsub 25 pin) : PF Input Port 5, PF Output Port 4

Each Port can be programmed with a function from next Table.

#### 36-1. PF Input Port

External HOOK	Open → OFF HOOK, Low → ON HOOK
CH Select A	The Channel changes to Remote Channel
CH Select B	1~15. If CH Select A~D are set "H" or "Open", the channel is selected by using the [ ^ ]/[ v ] keys or UP/DOWN Knob. (User Channel)
CH Select C	
CH Select D	
External PTT	Open → PTT OFF, Low → PTT ON
Scan	Open → Scan OFF, Low → Scan ON
Home Channel	Open → Current Channel, Low → Home Channel
Light Sense	Open → LCD Backlight is controlled by [DIM], Low → LCD Backlight is set "Low"
Repeater SW	Open → Repeater inactive, Low → Repeater Active * Dual BAND configuration only
External Monitor	Open → Monitor OFF, Low → Monitor ON

#### 36-2. PF Output Port

AUX A	Pressing [AUXA] once → Low, Pressing [A] [AUXA] again → OPEN-COLLECTOR
AUX B	Pressing [AUXB] once → Low, Pressing [B] [AUXB] again → OPEN-COLLECTOR
AUX C	Pressing [AUXC] once → Low, Pressing [C] [AUXC] again → OPEN-COLLECTOR
TOR	Receiving correct QT/DQT → Low, Not receiving correct QT/DQT → OPEN-COLLECTOR
COR	BUSY → Low, Not BUSY → OPEN-COLLECTOR

### 37. Timed Power Off

This function works as "Automatic Power Switch Off".

Timed Power Off timer starts from the ignition-off. After the timer expires, the RADIO will automatically turn off. The timer will be reset if the ignition is turned on and off.

This function requires ignition-sense. Connect the ignition-line to the 9-pin connector which is located at the rear of the RADIO.

After the timer expires, you can turn the transceiver on again with 2 methods below.

- 1) Timed power off function (Default)  
Press the power switch.
- 2) Ignition function & Timed power off function  
Turn the ignition on.

### 38. Emergency

- **Active tome**  
Automatic transmission period in the emergency mode.
- **Interval Time**  
Interval time between the automatic transmissions.
- **Duration of Locator Tone 1**  
Duration of an alert tone before the automatic transmission is performed.
- **Duration of Locator Tone 2**  
Duration of an alert tone after the automatic transmission is performed.
- **Emergency Channel Display**  
Setting for the display in the emergency mode.  
The transceiver can be programmed to display "EMERGENCY" channel name when it is in emergency mode.  
If you set to "off" by KPG-44D the transceiver shows selected group/channel/status before entering to the emergency mode however the transceiver is in an emergency mode.

## OPERATING FEATURES

- **Emergency Mode Type**

Speaker mute on or off in the emergency mode.

- **Emergency Type**

Select an Emergency code format from DTMF, MSK, ANI board or OFF (Disabled).

- **Emergency DTMF ID**

The emergency DTMF ID code when you select DTMF in the emergency type.

- **Emergency Call Fleet**

The emergency fleet number when you select MSK in the emergency type.

- **Emergency Call ID**

The ID number when you select MSK in the above emergency type.

### 39. MSK PTT ID

- **Side Tone**

A tone to notify the voice transmission is allowed after sending the MSK PTT ID (Connect ID).

- **Fleet (Own)**

- **ID (Own)**

Configure the Fleet/ID of the MSK PTT ID (Fleet Sync Format).

- **Data TX Mod. Delay**

Delay time of transmitting the MSK ID after the transceiver enters the transmission mode.

### 40. Power On Text

To display the Power on text for approximately 2 seconds when the transceiver is turned on.

### 41. Data Programming (PC Mode)

#### 41-1. Preparation and Connection

TK-790 transceiver is programmed by using a personal computer, programming interface cable KPG-43, and programming software KPG-44D.

The programming software can be used with an IBM-PC or compatible machine. Figure 1 shows the setup for programming.

#### 41-2. Programming Interface Cable KPG-43 Description

The KPG-43 is required to interface TK-790 to the computer. It has a circuit in its D-sub 25 pin connector case that converts RS-232C logic level to TTL level.

KPG-43 is used to connect between TK-790 microphone connector and RS-232C serial port of computer.

#### 41-3. Programming Software KPG-44D Description

KPG-44D is the programming software for TK-790 supplied on a 3.5" floppy disk. This software runs under MS-DOS version 3.1 or later on an IBM-PC/XT, AT, or PS2 or compatible machine.

The data can be input to or read from TK-790 and edited on the screen. The programmed or edited data can be printed out. It is also possible to tune the transceiver.

We recommend that install KPG-44D for example to harddisk first then use it.

KPG-44D instruction manual part No. : B62-1011-XX.

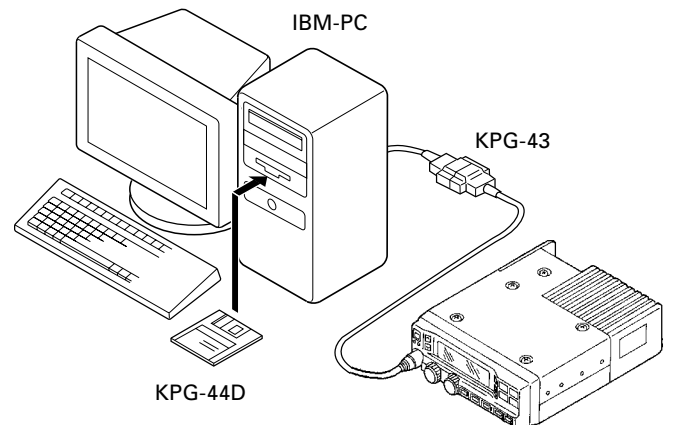
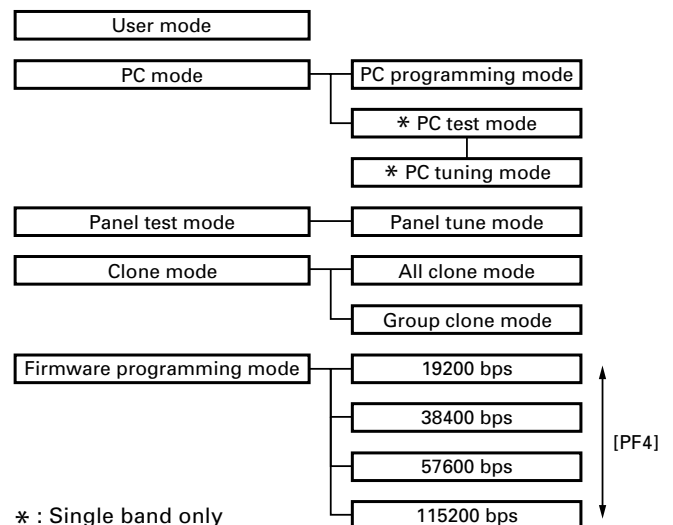

Fig. 1

### 42. Mode



# TK-790/(B)/H(B)

## OPERATING FEATURES

Mode	Function
User mode	Customer use this mode
PC mode	Communication between the radio and PC (IBM compatible). It requires the KPG-44D.
Panel test mode (Refer to ADJUSTMENT)	Dealer uses to check the fundamental characteristics.
Panel tune mode (Refer to ADJUSTMENT)	Dealer uses to tune the radio.
Clone mode	Programmed data is transferred from one transceiver to another by using a cloning cable.
Firmware programming mode	Re-write the firmware of the flash ROM. <b>Note</b> : When programming the firmware, it is best to copy the data from the floppy disk to your hard disk, then from the hard disk to the CPU. Directly copying from the floppy disk to the CPU may not work because the access speed is too slow.

### 42-1. How to Enter Each Mode

Mode	Operation
User mode	Power on
PC mode	Connect the PC and turn the power on. Then the radio can be controlled by the FPU.
Panel test mode	Hold down the [PF1] key, turn the radio power on.
Panel tune mode	Press the [GR ^] key from the panel test mode.
Clone mode	Hold down the [PF5] key, turn the radio power on.
Firmware programming mode	Hold down the [PF2] key, turn the radio power on.

### 43. PC Tuning Mode

When making adjustment while in PC tuning mode, modify the KPG-43 programming interface cable as described below.

1. Remove the two screws from the plug cover, then lift the cover from the plug.

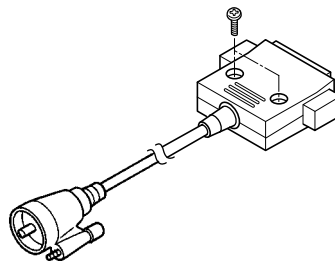

2. Solder the lead wire onto the MIC tab on the PCB, and the ground wire onto the ME tab.

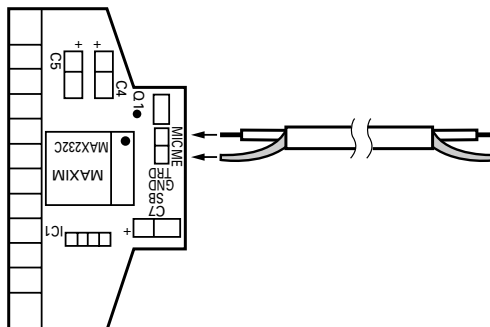

3. Create a hole in the casing (as shown in the illustration) then fit the cable into the hole. Replace the cover and secure it using the two screws.

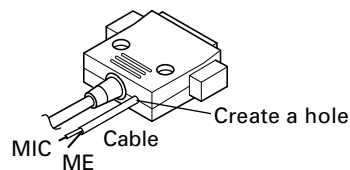

## OPERATING FEATURES

### 44. Clone Modes

There are two clone modes : "All Clone Mode", in which all data programmed in one transceiver with the "FPU" is copied to another transceiver, and "Group Clone Mode", in which group data in one transceiver is copied to a group in another transceiver.

The cloning operation is performed from the master side transceiver.

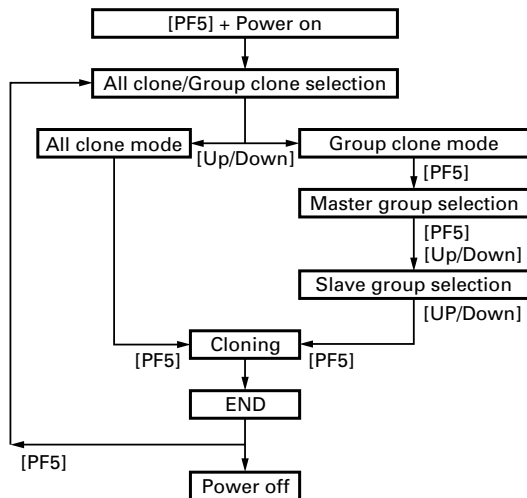

#### 44-1. To Enter the Clone Mode and Connect Transceivers

- (1) Hold down the [PF5] key and turn on the power switch on the master side transceiver.  
Turn on the power switch on the slave side transceiver as usual.
- (2) Connect the master and slave side transceivers with a cloning cable.

#### 44-2. All Clone

1. Enter the All Clone Mode from the clone mode with the [Up/down] knob.
2. Press the [PF5] key to start cloning.

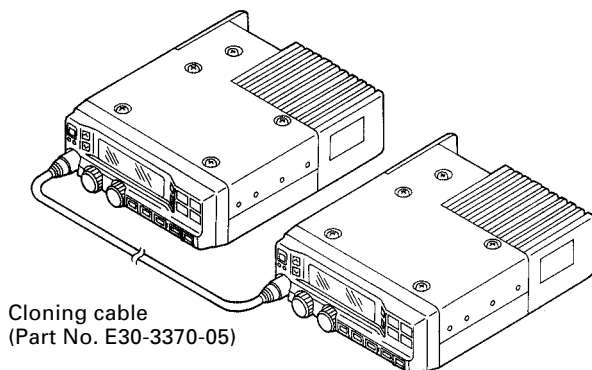
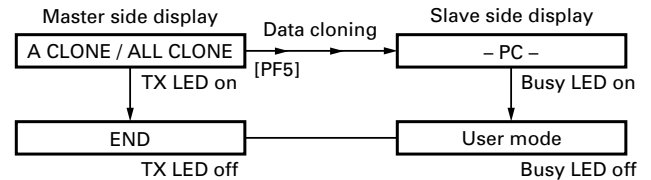

Fig. 2

#### 44-3. Group Clone

1. Enter the group clone mode from the clone mode with [Up/Down] knob.
2. Press the [PF5] key to enter the master group select mode. Select the master group with [Up/Down] knob.



3. Press the [PF5] key to enter the slave group select mode. Select the slave group with [Up/Down] knob.
4. Press the [PF5] key to start cloning.

**Note :** The transceiver does not enter the clone mode if it is disabled with the FPU. To clone the transceiver both transceivers must be same. If the panels, frequency ranges, optional board are different, they cannot be cloned.

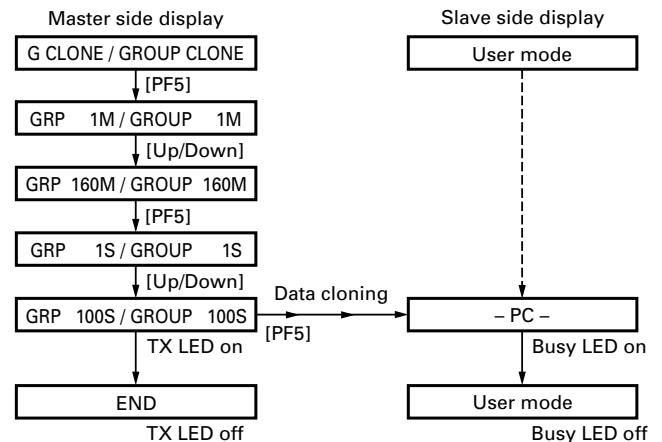

# TK-790/(B)/H(B)

## INSTALLATION

### 1. Contents

- Front panel kit (KCH-10, KCH-11)  
Description and use of the knob supplied with the KCH-10/11
- Optional voice scrambler function  
Voice scrambler use and connection
- Optional ANI function  
ANI board connection
- Ignition sense cable (KCT-18)  
Description of the ignition function and timed power off function and connection
- External speaker (KES-4)  
KES-4 connection method and modification for increasing the speaker output of the control head
- Horn alert function  
Modification for changing the function of the ACC terminal for horn alert
- Accessory terminal function  
Description and use of D-SUB 25-pin ACC terminals, "MI/DI" and "SB"
- Connection with remote kit  
Modification of the radio to use KRK-5, KRK-6DH, KRK-7DB, or KRK-8DBH

### 2. Front Panel Kit (KCH-10, KCH-11)

#### 2-2. Connection with TK-790(B)/H(B)

1. Remove the upper and lower halves of the case of the TK-790(B)/H(B).
2. Connect the lead (W501) with a connector of the control unit (X57-561 B/3) to CN1 of the KCH-10 or KCH-11.
3. Install the KCH-10 or KCH-11 on the radio using the screws (N32-3006-46) ( ❶ ) supplied with the front panel kit. Take care not to get the lead between the KCH-10 or KCH-11 and an edge of the case. (You can install the panel upside down if necessary to install the radio.)
4. Reinstall the upper and lower halves of the case.
5. Connection the short plug for the accessory connector (9-pins) on the rear of the radio.

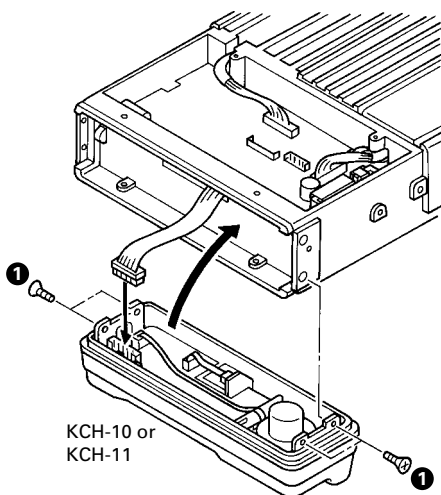

Fig. 1

### 2-3. Install the accessory knobs

When a function is set by the programming software (KPG-44D), the key legend can be changed by inserting the accessory knobs into PF1 to PF9 of the KCH-11 (PF1 to PF5 : KCH-10). The accessory contains a set of 30 knobs : AN, D/A, DIM, HA, HC, IC, MON, OPT, OST, PA, RCL, RPT, SCN, SP, SPM, SQ, TA, ^, v, CH1, CH2, CH3, CH4, CH5, AUX A, AUX B, AUX C, EMG, and blank.

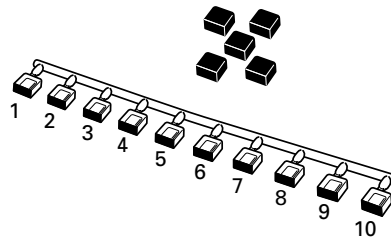
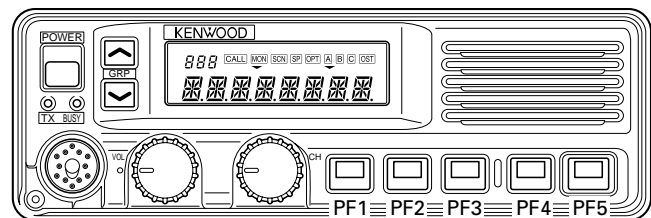

Fig. 2

No.	K29-5276-*3	K29-5277-*3	K29-5305-*3
1	AN	RCL	CH1
2	D/A	RPT	CH2
3	DIM	SCN	CH3
4	HA	SP	CH4
5	HC	SPM	CH5
6	IC	SQ	AUX A
7	MON	TA	AUX B
8	OPT	^	AUX C
9	OST	v	EMG
10	PA	No printing	

#### KCH-10



#### KCH-11

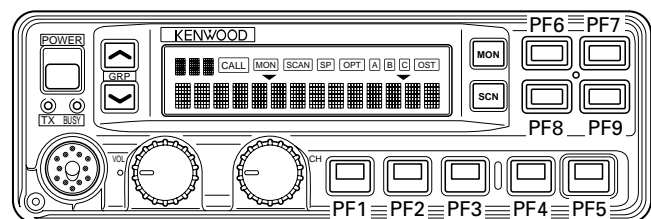
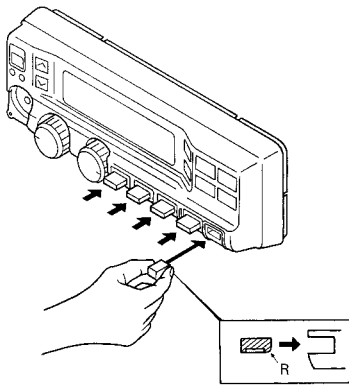
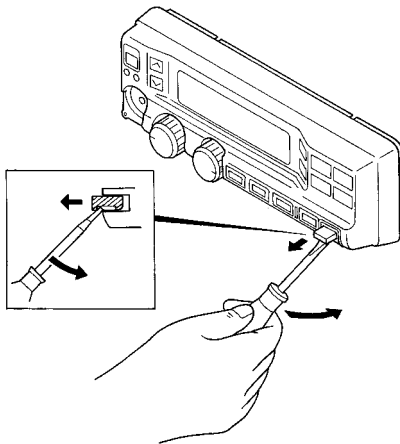

Fig. 3

## INSTALLATION



**Fig. 4-1 Knob insertion**



**Fig. 4-2 Knob removal**

### 3. Optional Voice Scrambler Function

The optional voice scrambler function can be used by two methods.

1. Assign this function to the OPT key by using the programming software (KPG-44D).  
When the OPT key is pressed, the **[OPT]** indicator comes on, and the optional (scrambler) function is enabled. When the key is pressed again, the **[OPT]** indicator goes off and the function is disabled.
2. Assign the optional scrambler function to each channel by using the programming software (KPG-44D). The optional scrambler function can be used without pressing the OPT key.

#### 3-1. Code setting

The code can be set by two methods.

1. Hold down the OPT key to enter the code setting mode. Codes 1 to 16 will be displayed. Set a code by turning the [Up/Down] knob. When the OPT key is pressed again, the code setting mode terminates.
2. Set a code for each channel by using the programming software (KPG-44D).

#### 3-2. Voice scrambler board connection

##### • Modification

1. Remove the upper half of the case of the TK-790.
2. Remove R515 and R604 on the control unit (X57-561 B/3) (Refer to page 21).

##### • Connection

The functions of pins of CN508 on the control unit (X57-561 B/3) are shown in the figure.

Join the CN508 connector to the voice scrambler board via the E37-0808-05 connector cable.

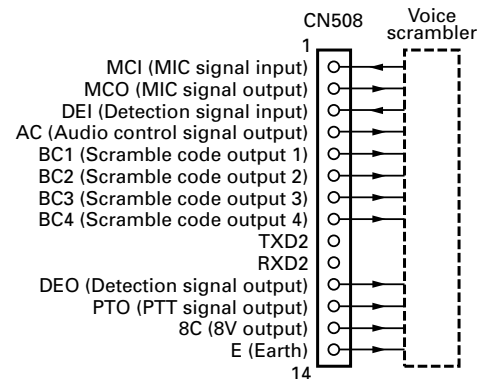
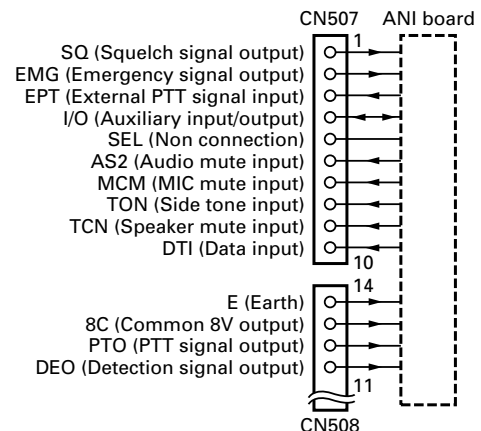

**Fig. 5**

### 4. Optional ANI Function

##### • Connection

Join the CN507 connector to the ANI board via the E37-0809-05 connector cable, and the CN508 connector to the ANI board via the E37-0808-05 connector cable.



**Fig. 6**

## INSTALLATION

### 5. Ignition Sense Cable (KCT-18)

The KCT-18 is an optional cable to use the following functions:

#### 5-1. Ignition function

The ignition function allows you to turn the transceiver's power on and off with the ignition key of your car. When you are driving with the ignition key on, the horn alert function is disabled.

#### 5-2. Timed power off function

The timed power off function turns the transceiver's power off the time specified with the programming software (KPG-44D) after the ignition key is turned off. When you are driving with the ignition key on, the horn alert function is disabled.

The ignition sense function and the timed power off function can be used at the same time.

#### 5-3. Modification

##### • If the TK-790 and KCH-10 or KCH-11 are used

1. Remove the short plug from the accessory connector (9 pins) on the back of the transceiver.
2. Insert the KCT-18 into pin 1 (IGN).
3. Remove the upper half of the case of the TK-790.
4. Set jumper resistors (0 ohm), R504, R506, R742 and R743, on the control unit (X57-561 B/3) as shown in Table 1 (Refer to page 21).
5. Reinstall the upper half of the case.

##### • When the remote kit is used

If the accessory connector (9 pins) on the rear of the transceiver is available, use the method described above. (If the KRK-7DB or KRK-8DBH is used, use the accessory connector (9 pins) on the back of radio 1.)

If the accessory connector (12 pins) on the back of the control head is used:

1. Remove the plug from the accessory connector (12 pins) on the back of the control head.
2. Cut off the end of the rubber cap (accessory), insert the KCT-18 into the cap, and insert it into pin 1 (IGN) of the short plug.
3. Install the short plug and rubber cap on the connector on the rear of the control head, then clamp the bottom of the rubber cap with the supplied tie wrap.
4. Remove the upper half of the case of the TK-790.
5. Set jumper resistors (0 ohm), R504, R506, R742 and R743, on the control unit (X57-561 B/3) as shown in Table 1 (Refer to page 21).
6. Reinstall the upper half of the case.

**Note :** If the KCT-18 is used for the KRK-8DBH, use the 9-pin plug on the back of radio 1 or the 12-pin plug on the back of head 1. The plugs on radio 2 and head 2 cannot be used. If the KCT-18 is used for the KRK-7DB, use the 9-pin plug on the back of radio 1 or the 12-pin plug on the back of the head. The plug on radio 2 cannot be used.

Available function when KCT-18 is connected	R504	R506	R742	R743
Horn alert function OFF during driving, Timed power off function (Default)	Present	Absent	Present	Absent
Horn alert function OFF during driving, Ignition function	Absent	Present	Present	Absent
None (The transceiver cannot be turned on.)	Absent	Absent	Present	Absent
HA function OFF during driving, Ignition function & Timed power off function	Present	Absent	Absent	Present

**Table 1 R504, R506, R742 and R743 setup chart (Refer to page 21)**

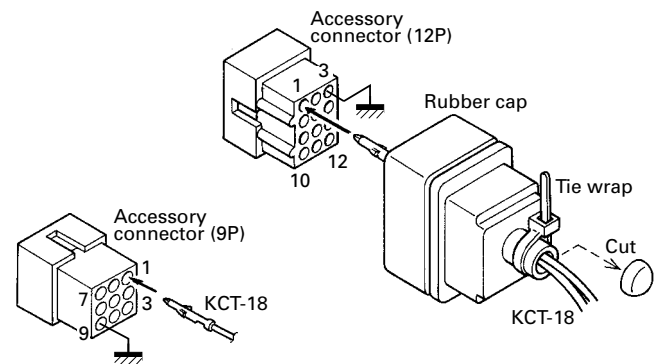

**Fig. 7**

### 6. External Speaker (KES-4)

The speaker output from the TK-790 is as follows:

1. The KCH-10 has a built-in speaker (3W/8 ohms).
2. The KCH-11 does not have a built-in speaker.
3. The external speaker output from the accessory connector (9 pins) on the back of the transceiver is 13W/4 ohms. Use the KES-4.
4. The speaker output from the accessory connector (12 pins) on the back of the control head is 2W/4 ohms. If the remote kit (KRK-5, KRK-6DH, KRK-7DB or KRK-8DBH) is used, use the KSP-1A or KES-4. If the KSP-1A is used, do not attempt to modify the transceiver to increase the audio output.

**Note :** Since the TK-790 uses a BTL audio amplifier, do not ground the speaker output pin.

## INSTALLATION

### 6-1. Connection for the KES-4 with the TK-790

- **When taking the AF output from the accessory connector (9-pin) on the rear of the radio**

The following tools are required for changing the connector.

#### Extracting tool

the following extracting tool is recommended :  
Molex Inc. Order No. : 11-03-0002

1. Remove the connector with jumper from the external speaker connector on the rear panel of the radio (Fig. 8-1).

Note : Save the jumper, which is required when the radio is used without the external speaker.

2. Remove the terminals with the jumper from the connector housing holes number 3 and 6 using the extracting tool.

#### Removing the jumper lead (Fig. 8-2)

- 1) Insert the extracting tool (11-03-0002) into the connector while pushing the jumper lead in the direction of (a).
  - 2) Push the extracting tool into collapse the barbs of the crimp terminal.
  - 3) Pull out the lead while continuing to push the extracting tool in the direction (b).
3. Reinsert the terminal with the black and white stripe lead into hole number 2, and the terminal with the black lead into hole number 6 (Fig. 8-3).
  4. Attach the connector to the external speaker connector on the radio.

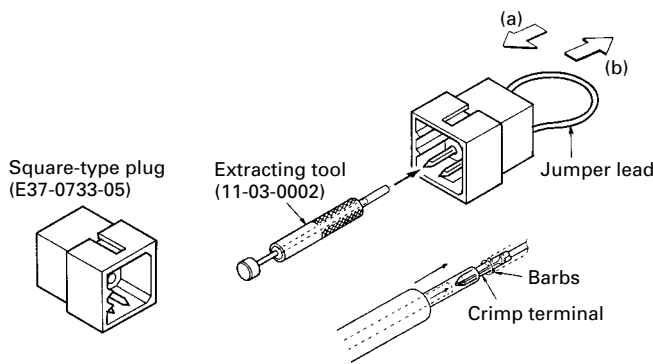

Fig. 8-1

Fig. 8-2

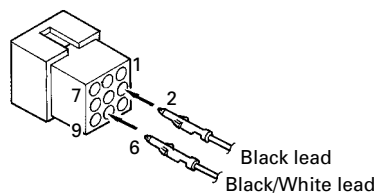

Fig. 8-3

### 6-2. Connection for the KES-4 with the remote kit (KRK-5, KRK-6DH, KRK-7DB, KRK-8DBH) (When output is from the 12-pin accessory connector on the rear of the control head : remote operation)

- **Modification of plug (12-pin)**

1. Remove the plug from the accessory connector (12-pins) on the rear of the control head.
2. Cut off the end of the rubber cap, insert the KES-4 speaker cable into the cap, and insert it into pins 10 and 11.
3. Install the plug and rubber cap on the accessory connector on the rear of the control head, then clamp the bottom of the rubber cap with the supplied tie wrap.

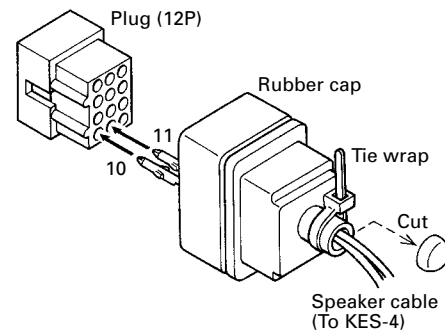

Fig. 9

- **If the KCH-10 is used**

If the KSP-1A or KES-4 is connected to the 12-pin accessory connector, cut the internal speaker wire at the base of the speaker.

If the internal speaker is used, cut the wire connected to pins 10 and 11 of the 12-pins accessory connector at the base of the connector (Fig. 10).

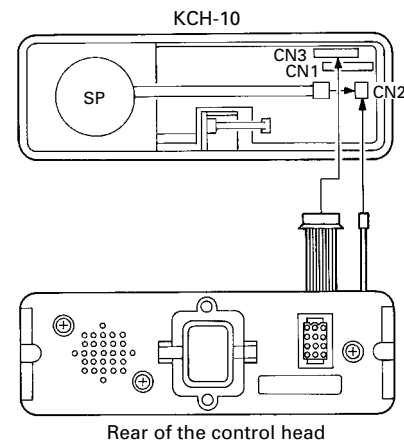

Fig. 10

## INSTALLATION

### 6-3. Modification to increase the audio output of the control head

The speaker output can be increased to 13W by moving jumper resistor (0 ohm) R628 on the control unit (X57-561 B/3) to R627. In this case, the KCH-10 internal speaker cannot be used because the maximum input (3W) of the internal speaker is exceeded. Therefore, use the KES-4.

**Note :** Even if the KRK-6DH is modified in this way, the audio output of head 2 cannot be increased. To increase the audio output of head 2 of the KRK-8DBH, modify radio 2 in the same manner.

### 6-4. Use as public address speaker

1. Remove the short plug from the 9-pin accessory connector on the rear of the radio. (Remove the jumpers as described in Section 5-1.)
2. Insert the KES-4 speaker leads into pins 7 and 8.
3. If you remove jumper shorting pins 3 and 6, the 20W PA (public address) voice signal is output from pins 7 and 8. (Only when the PA or SP switch is on.)
4. If you use the radio with pins 3 and 6 shorted, the internal speaker is available (when the KCH-10 is used). The KCH-11 does not contain a speaker.

**Note :** Relation ship between accessory connector (9-pins) connection and speaker output.  
When pins 3 and 6 are shorted ; The 3W internal speaker is used (KCH-10 only).  
When pins 3 and 6 are open and output is from pins 7 and 8 ; The 20W external speaker is used.

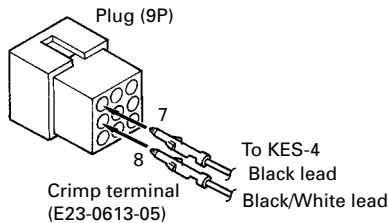

Fig. 11

## 7. Horn Alert Function

The HR1 pin of the accessory connector (9-pin) on the rear of the transceiver is an open collector and the maximum current is 100mA. The maximum available current can be increased to 1A by installing a relay.

1. Remove the upper half of the case of the TK-790.
2. Move jumper resistor (0 ohm) R691 on the control unit (X57-561 B/3) to R692. To make the HR2 pin, remove R692 (Refer to page 21).
3. Remove screws and erect the PC board. Install and solder relay K501 (Part No. : S76-0407-05).
4. Reinstall the PC board and the upper half of the case.

	Default	Modification 1	Modification 2
R690	Present	Present	Absent
R691	Present	Absent	Absent
R692	Absent	Present	Present
State			

Table 2 (Refer to page 21)

## 8. Accessory Terminal Function

### 8-1. 25-pin accessory terminal

#### • Pin 13

MI/DI (MIC Signal Input/Output or Data Audio Input)  
This pin has one of the two functions listed in Table 3 by setting jumper resistors (0 ohm) R640 and R641 on the control unit (X57-561 B/3) (Refer to page 21).

#### 1) MIC signal input/output

This pin is directly connected to the MIC input pin of the transceiver, so it has the same function as the MIC input pin. When the input is 5mV/3 kHz, DEV (600 ohms) modulation is obtained. The MIC input is output from the transceiver panel as it is.

#### 2) Data audio input

The signal from this pin passes through the LPF (fc: about 10kHz), is summed with the MIC AMP output, and goes to the modulator. Therefore, it is not preemphasized.

#### • Pin 14

SB (DC Power Output After Power Switch)  
The maximum output (13.6V : TK-790/(B), 13.4V : TK-790H(B) / 0.5A) can be obtained by modifying the control unit as follows:  
Short the land of the print pattern near CN505 of the control unit (X57-561 B/3).

R640	R641	Function
Present	Absent	MIC signal input/output
Absent	Present	DATA audio input : Default

Table3 (Refer to page 21)

## 9. Connection with the Remote Kit

When the KRK-5, KRK-6DH, KRK-7DB or KRK-8DBH is used, set chip resistors and transistors as shown in the table below.

	KRK-5	KRK-6DH	KRK-7DB	KRK-8DBH
Radio 1	Unnecessary			
Radio 2	-		Remove R546 and R661 Move R602 to R705.	

Table 4 (Refer to page 21)

## INSTALLATION

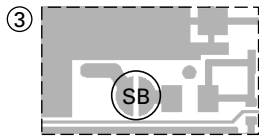
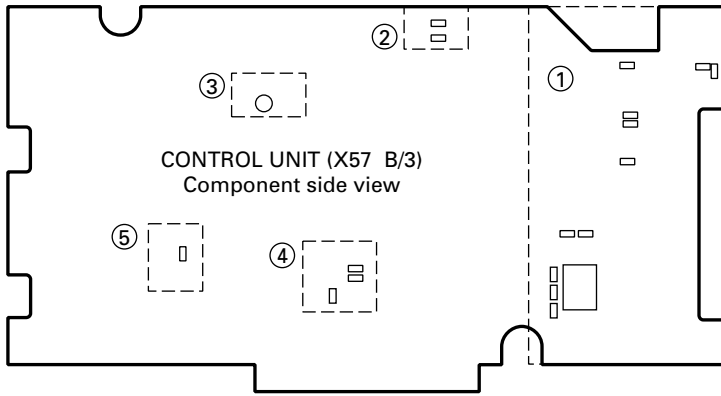

Accessory terminal function (Page 20)

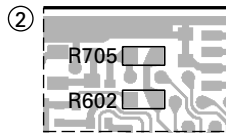

Connection with the remote kit (Page 20)

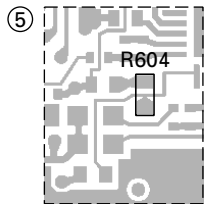

Voice Scrambler (Page 17)

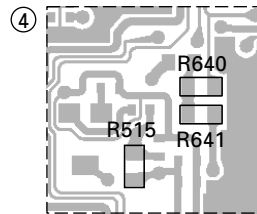

R515 : Voice Scrambler (Page 17)

R640,641 : Accessory terminal function (Page 20)

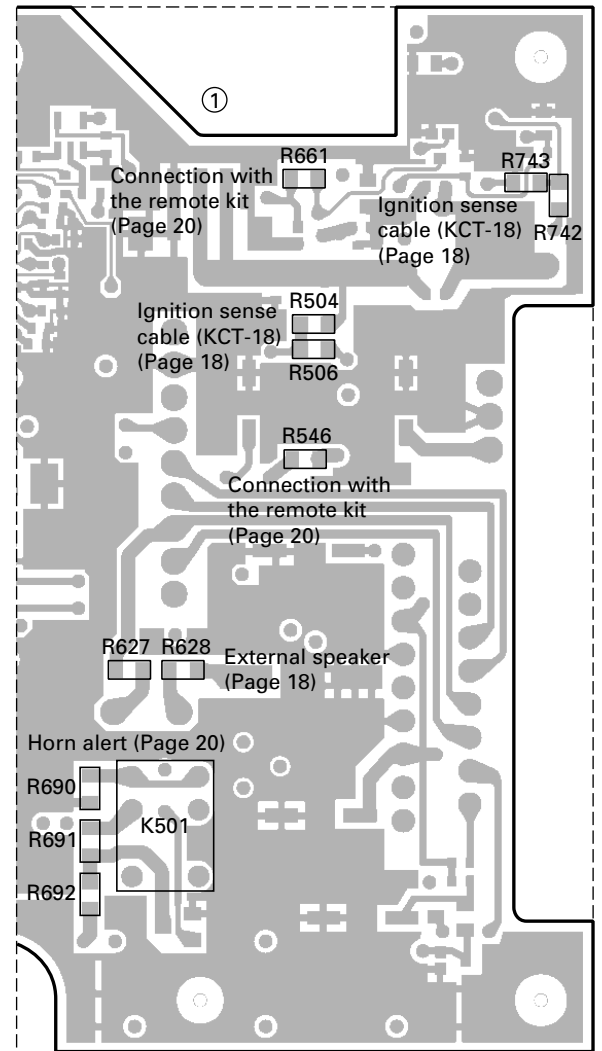

# TK-790/(B)/H(B)

## DISASSEMBLY FOR REPAIR (TK-790/(B))

### 1. Removing the Case and Shield Cover

1. Remove the 9 screws ( ❶ ), and remove the upper and lower halves of the case. (Remove the 4 screws holding the upper half and the 5 screws holding the lower half.)
2. Remove the shield cover ( ❷ ).

### 2. Removing the TX-RX Unit (X57-561 A/3)

1. Remove the 7 screws ( ❸ ), and remove the PLL shield case.
2. Remove the connector (CN201) and coaxial plugs (CN104, CN203) from the final unit, and remove the flat cable (CN202) upwards from the control unit (CN502).
3. Remove the 5 screws ( ❹ ).

### 3. Removing the Final Unit (X57-561 C/3)

1. Remove the 2 screws ( ❺ ) holding the power module to the frame.
2. With a screwdriver, remove the leaf spring ( ❻ ) holding the Q2 to the frame.
3. Desolder the power module.
4. Remove the 2 screws holding the lead terminal from DC connector (2P) on the rear.
5. Remove the 8 screws ( ❼ ) holding the PC board.
6. Desolder CN4 on the antenna connector.

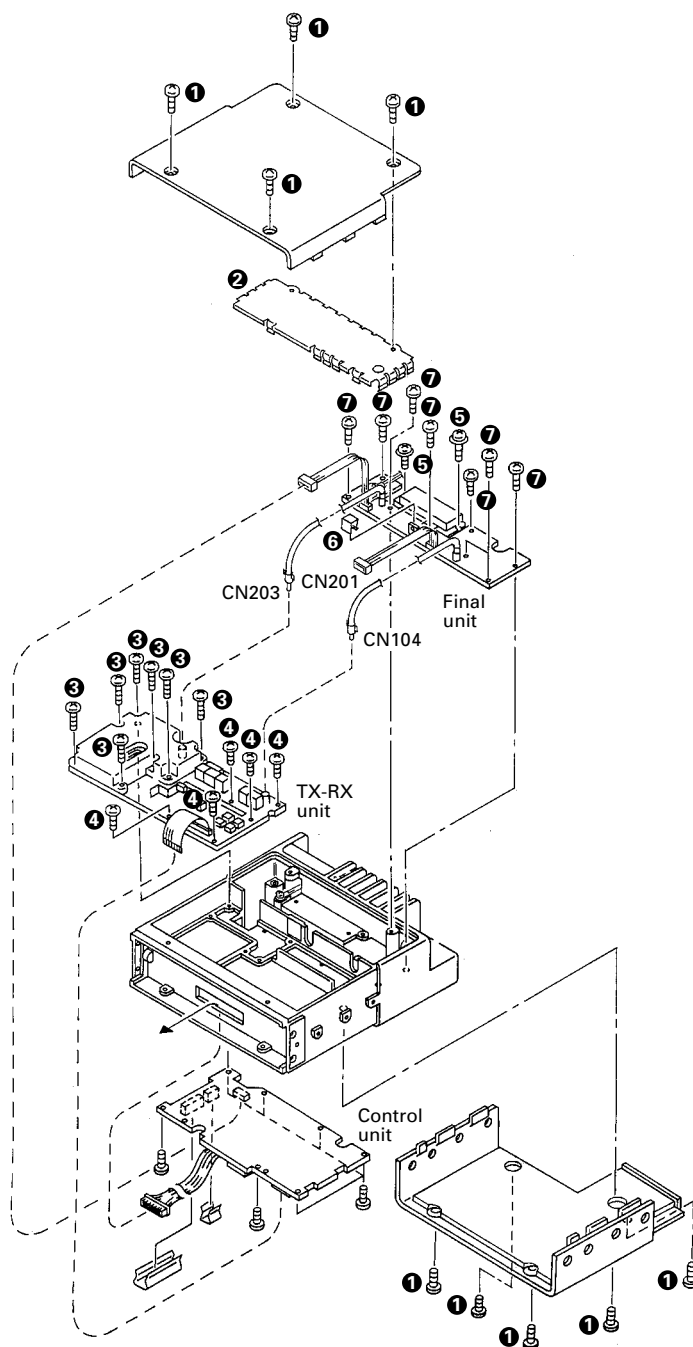

## DISASSEMBLY FOR REPAIR (TK-790H(B))

### 1. Removing the Case and Shield Cover

1. Remove the 12 screws ( ❶ ), and remove the upper and lower halves of the case. (Remove the 6 screws holding the upper half and the 6 screws holding the lower half.)
2. Remove the 2 screws ( ❷ ), and remove the shield cover.

### 2. Removing the TX-RX Unit (X57-561 A/3)

1. Remove the 7 screws ( ❸ ), and remove the PLL shield case.
2. Remove the connector (CN201) and coaxial plugs (CN104, CN203) from the final unit, and remove the flat cable (CN202) upwards from the control unit (CN502).
3. Remove the 5 screws ( ❹ ).

### 3. Removing the Final Unit (X45-356)

1. Remove the 2 hexagonal bosses ( ❺ ).
2. Remove the 3 screws ( ❻ ) holding the power module and transistor to the frame.
3. Desolder the power module.
4. Remove the 1 screw ( ❼ ) holding TH1.
5. Remove the 4 screws ( ❼ ) holding the final transistor.
6. Remove the 2 screws ( ❸ ) holding the lead terminal from DC connector (4P) on the rear.
7. Remove the 13 screws ( ❾ ) holding the PC board.
8. Desolder W3 on the antenna connector.

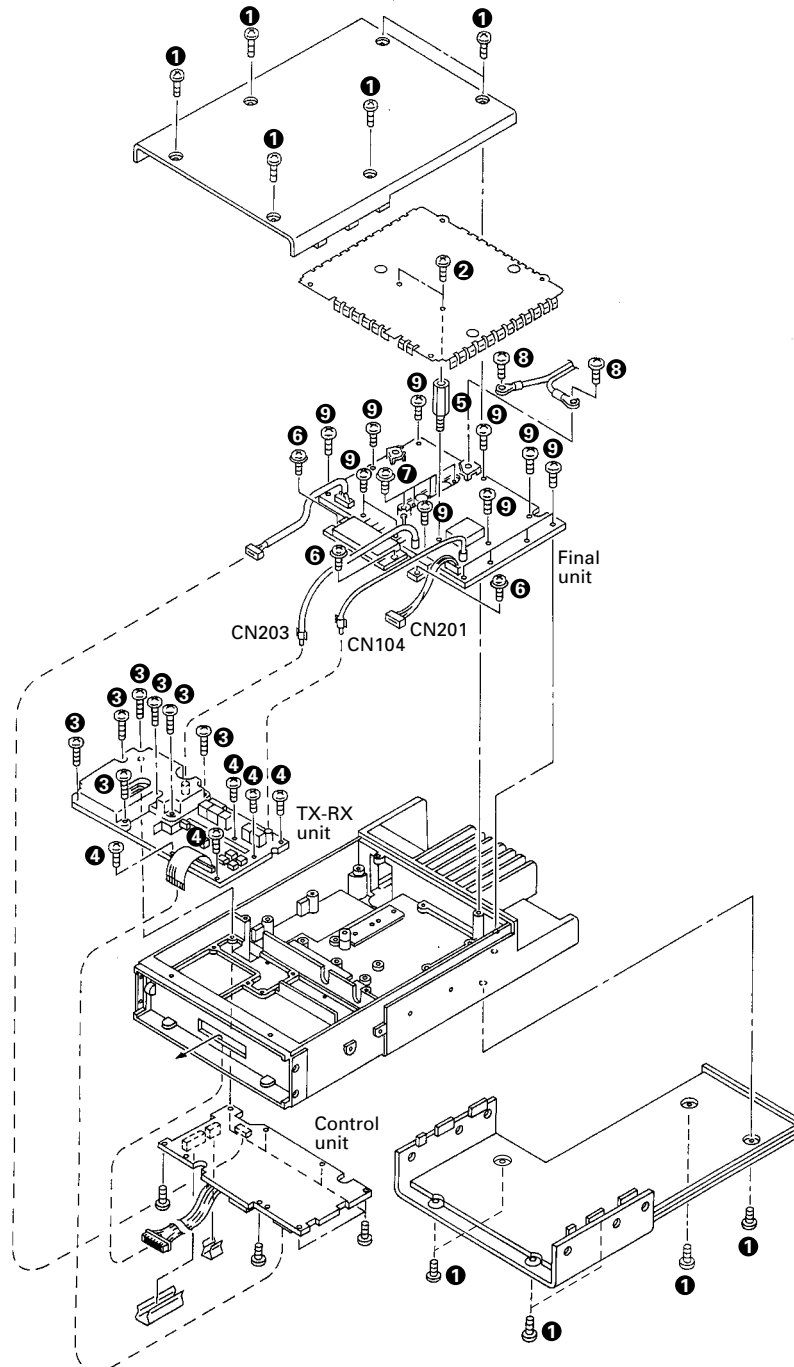

# TK-790/(B)/H(B)

## DISASSEMBLY FOR REPAIR

### 4. Removing the Control Unit (X57-561 B/3)

1. Remove the 8 screws ( ❶ ).
2. With a screwdriver, remove the 2 leaf springs holding the ICs to the frame ( ❷ ).
3. Remove the flat cable (CN502).
4. Remove the 2 connectors CN501 and CN506.
5. Remove the connector (CN505) from D-sub connector (25P) on the rear.

### 5. Removing the Accessory Connector on the Rear

1. Confirm that the screw holding +DC cable (red) and the screw holding -DC cable (black) of the final unit are removed, and that CN506 of the control unit (X57-561 B/3) is disconnected. Remove the 4 screws on the rear ( ❸ ).
2. Pull out the connector. (Take the connector terminals out through the opening in the frame.)

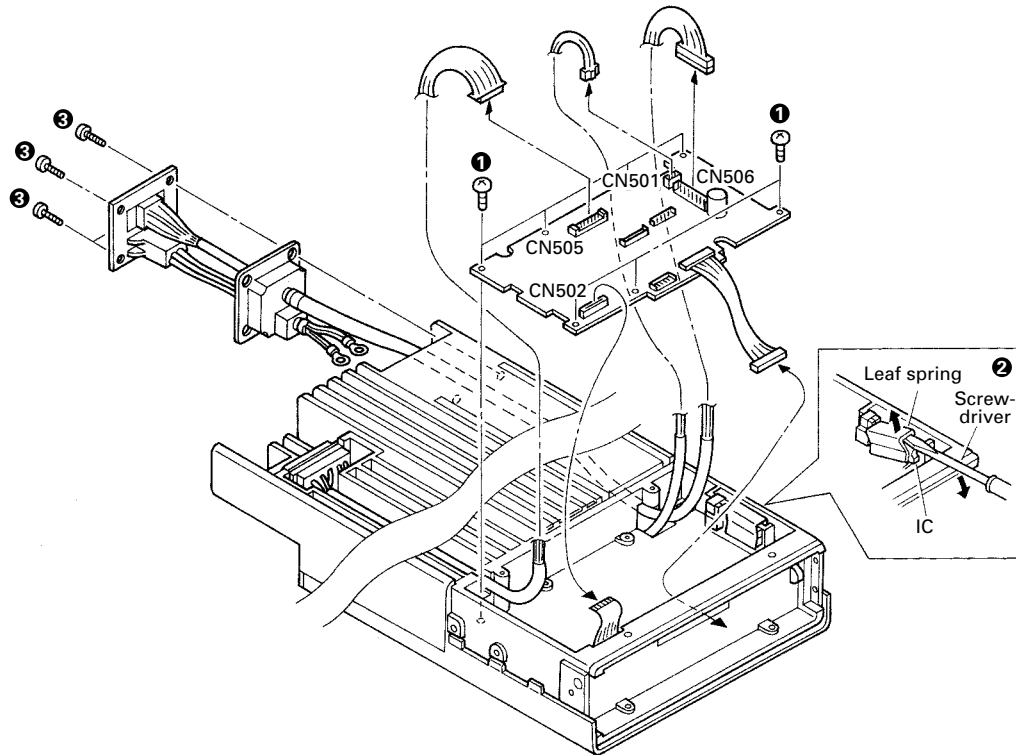

## DISASSEMBLY FOR REPAIR

### 6. Disassembly of the Display Unit (X54-3190) : KCH-10

1. Pull out the VOL and UP/DOWN knobs ( ❶ ).
2. Remove the 2 hexagonal nuts ( ❷ ).
3. Disconnect the 2 connectors (CN2 and CN4) of the display unit (X54-3190 A/3). You can remove the UP/DOWN encoder ( ❸ ).
4. Remove the waterproof seal ( ❹ ).
5. Remove the 4 screws ( ❺ ) holding the speaker and PC board fitting.
6. Remove the 3 screws ( ❻ ). You can remove the display units (X54-3190 A/3 and C/3) ( ❼ and ❽ ).
7. Remove the 3 screws ( ❾ ), and remove the sub-panel ( ❿ ) and keytop ( ⓫ ).

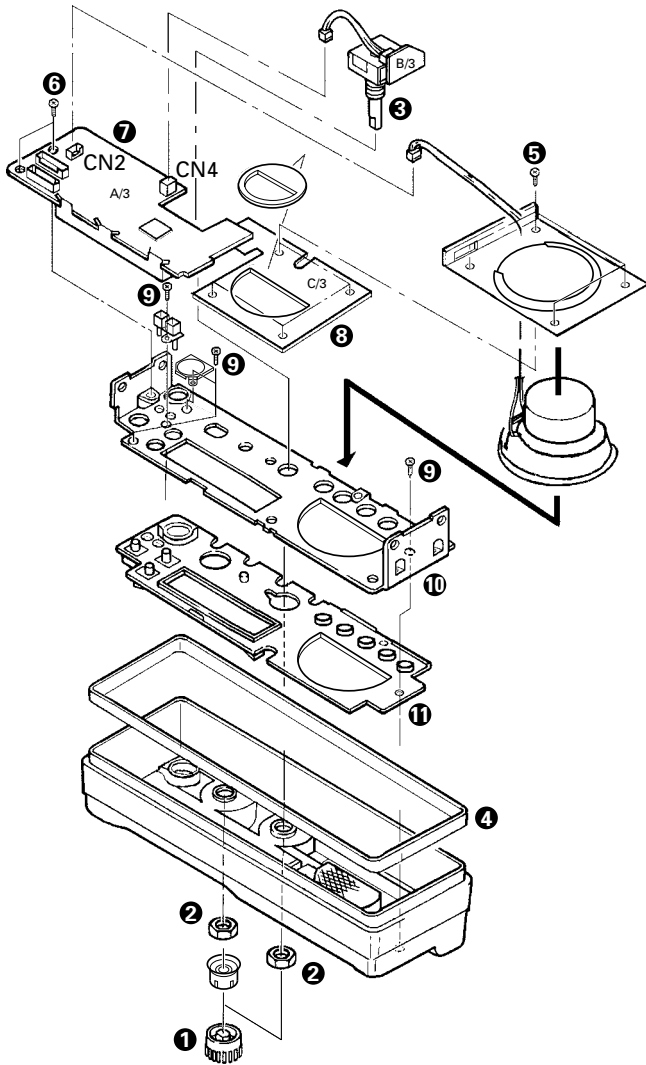

### 7. Disassembly of the Display Unit (X54-3200) : KCH-11

1. Pull out the VOL and UP/DOWN knobs ( ❶ ).
2. Remove the 2 hexagonal nuts ( ❷ ).
3. Remove the waterproof seal ( ❸ ).
4. Disconnect the connector (CN4) of the display unit (X54-3200 A/2), and remove the 5 screws ( ❹ ). you can remove the up/down encoder ( ❺ ) and display unit.
5. Remove the 4 screws ( ❻ ), and remove the sub-panel ( ❼ ) and keytop ( ❸ ).

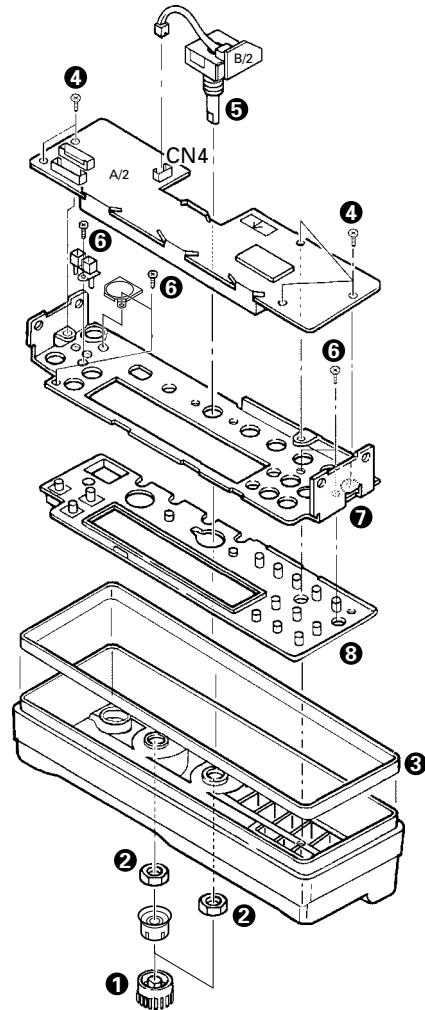

## CIRCUIT DESCRIPTION

### 1. Transmitter Circuit

#### 1-1. Microphone amplifier section (X57 B/3)

The audio input from the microphone is attenuated by VR501 and passes through the active high-pass filter (pre-emphasis circuit) in IC505, the compressor circuit in IC504, the IDC (limiter circuit) in IC505, the summing amplifier circuit in IC510, the active low-pass filter in IC510, the summing amplifier circuit in IC513, and the D/A converter in IC512, and is output from the CN502 to the CN202. Q504 is used as a microphone mute switch.

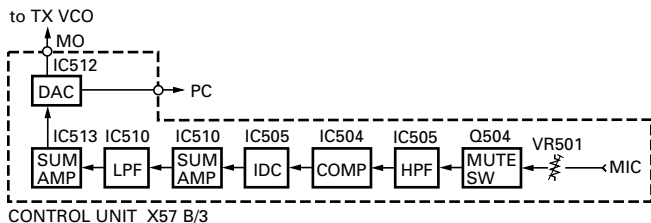

Fig. 1

#### 1-2. Modulation section (X57 A/3)

The signal from the MO terminal of the CN202 goes to D305 in the VCO, and the VCO is directly modulated. The transmit signal output from the VCO passes through switch D306, is amplified by Q201 and Q204, and is output from the CN203 to the CN1.

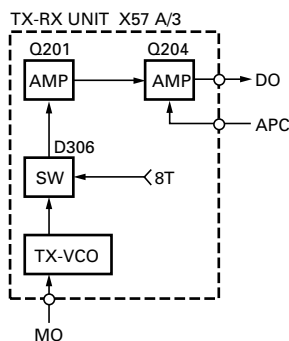

Fig. 2

#### 1-3. Final amplifier section (X57 C/3) : TK-790/(B)

The signal from the DO terminal of the CN1 is applied to drive the power module and the output is fed through transmit/receive switching diode ; D3,D4, low-pass filter, and CM coupler to the antenna connector.

CM coupler is a line for detecting traveling and reflected waves. Traveling waves are detected by D5 and fed through the APC control to differential amplifiers Q5, which compare the signal level with the reference voltage of PC tuned.

The output is amplified by DC amplifier Q1 to control APC DC amplifier Q2. Q1 controls the power supply voltage for the power module, keeping the transmitter output constant. To protect the transmitter power amplifier stages, there is protection circuit, against abnormal antenna loading.

If an abnormal antenna load is connected the reflected wave level increases. Reflected waves are detected by D6 and the output level is fed to the differential amplifier, leading to the transmitter output power being reduced in the way already described.

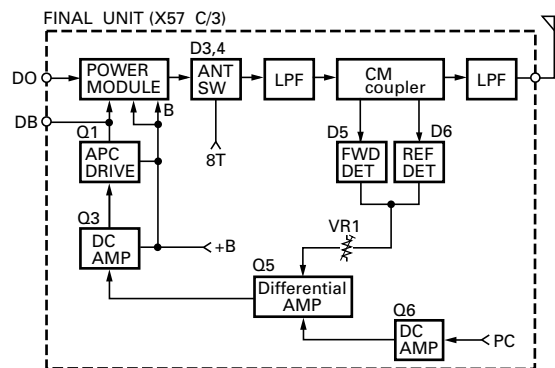

Fig. 3

#### 1-4. Final amplifier section (X45) : TK-790H(B)

The signal from the DO terminal of the CN1 is applied to drive the power module, and the output is divided into two signals which are amplified by Q6 and Q7. The signals are mixed and the resulting signal is fed through CM coupler, transmit/receive switching relay ; K1, and the low-pass filter to the antenna connector.

CM coupler is a line for detecting traveling and reflected waves. Traveling waves are detected by D1, D3 and fed through the APC control to differential amplifiers Q5, which compare the signal level with the reference voltage of PC tuned.

The output is amplified by DC amplifier Q4 to control APC DC amplifier Q2. Q4 controls the power supply voltage for the power module, keeping the transmitter output constant. To protect the transmitter power amplifier stages, there are two protection circuits which one is against abnormal antenna loading and the other is against overheating.

If an abnormal antenna load is connected, the reflected wave level increases. Reflected waves are detected by D2, D3 and the output level is fed to the differential amplifier Q5, leading to the transmitter output power being reduced in the way already described. If an abnormal high temperature is detected by the thermistor TH1, DC SW Q1 is made to reduce the reference voltage of the PC tuned. This also leads to the transmitter output power being reduced. Antenna switching is done by a relay K1 with 8R.

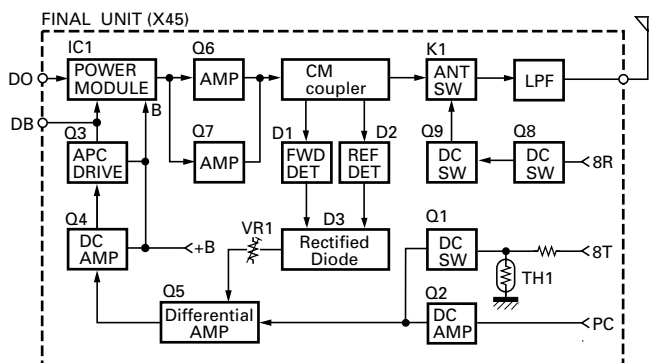

Fig. 4

## CIRCUIT DESCRIPTION

### 2. Receiver Circuit

Incoming signals from the antenna pass through a low-pass filter in the final unit of the transmitter system, and are switched to the front-end of the receiver system via a receive/transmit switch (switching diode D3 and D4 : TK-790/(B), switching relay K1 : TK-790H(B)).

The signal is then passed through an antenna matching coil. After passing through the BPF (L.C filter), it is amplified by the RF amplifier (Q101). The tuned varactor BPF (L110~112) is then passed, and it enters the 1st mixer.

The 1st mixer use a double balanced mixer (A101). The DBM is an excellent IM (intermodulation distortion) and image. The 1st mixer mixes the signal with the 1st local oscillator frequency and converts it to the 1st IF (44.85MHz). The signal is amplified by the 1st IF amplifier 1 (Q102).

The signal then passes through two monolithic crystal filters (XF101 : Wide, XF102 : Narrow) to remove unnecessary nearby frequency components. The signal from the XF101 or XF102 is used as the 1st IF signal.

The 1st IF signal is amplified by 1st IF amplifier 2 (Q107) and fed into IC101 in the FM IF IC. The IF signal is then mixed with the 2nd local oscillator frequency of 45.305MHz to generate the 2nd IF of 455kHz. The 455kHz signal is then passed through a ceramic filter (CF101, CF103 : Wide, CF102, CF104 : Narrow) and fed back into IC101 for additional amplification.

The AF signal output from IC101 then passes through the control unit's HPF and D/A converter IC. After entering the AF power amplifier (IC522), the signal is output from the speaker.

Item	Rating
Nominal center frequency	44.85MHz
Pass bandwidth	±5.5~7.5kHz or more at 3dB
Attenuation bandwidth	±25kHz or less at 40dB
Ripple	1.0dB or less
Insertion loss	3.0dB or less
Guaranteed attenuation	85dB or more at fo+400~+1000kHz fo-200~-1000kHz
Terminating impedance	3.2kΩ / -1.0pF

**Table 1 Crystal filter (L71-0512-05) : Wide (TX-RX unit XF101)**

Item	Rating
Nominal center frequency	44.85MHz
Pass bandwidth	±3.5kHz or more at 3dB
Attenuation bandwidth	±15kHz or less at 40dB
Ripple	1.0dB or less
Insertion loss	4.0dB or less
Guaranteed attenuation	85dB or more at fo+400~+1000kHz fo-200~-1000kHz
Terminating impedance	3.0kΩ / -0.5pF

**Table 2 Crystal filter (L71-0513-05) : Narrow (TX-RX unit XF102)**

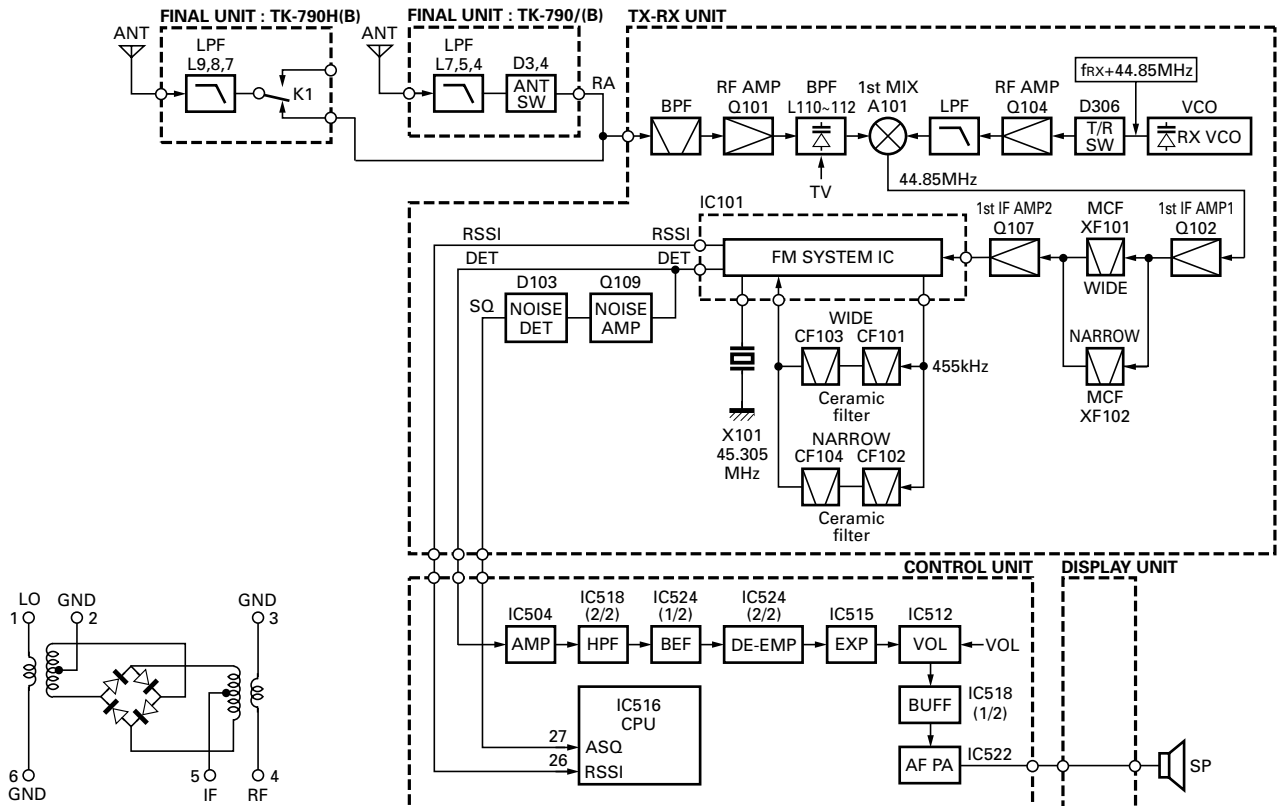

**Fig. 6 Double balanced mixer**

**Fig. 5 Receiver circuit**

## CIRCUIT DESCRIPTION

### 3. Squelch Circuit

The output from IC101 enters FM IC again, then passed through a band-pass filter. The noise component output from IC101 is amplified by Q109 and rectified by D103 to produce a DC voltage corresponding to the noise level.

The DC voltage is sent to the analog port of the CPU (IC516/pin 27). And IC101 output a DC voltage (RSSI) corresponding to the input of the IF amplifier. The CPU reads the RSSI signal via pin 26. IC101 determines whether to output sounds from the speaker by comparing the input voltage of pin 27 with the present value.

Only during scan, the RSSI DC voltage is used together with the noise wave detection pin's DC voltage (pin 27).

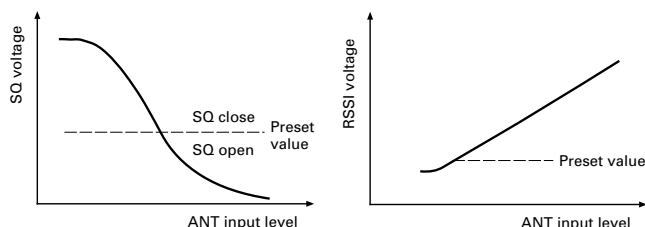

**Fig. 7 Squelch and RSSI voltage vs ANT input level**

### 4. RX BPF (L110~112)

The signals are then fed into band-pass filter that uses varactor diode tuning to reject unwanted signal components, and is fed to the 1st mixer.

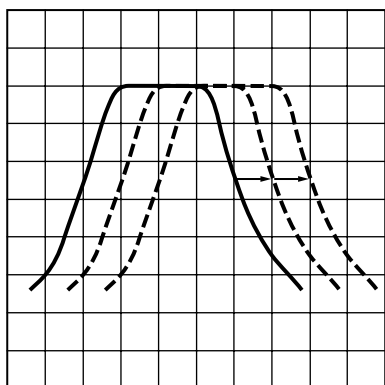

**Fig. 8**

### 5. VCO/PLL Circuit

The VCO of TK-790 consists of two VCO circuits which one oscillates the transmit signal with Q306 and the other does the first local receive signal with Q305.

Each oscillators are switched by turning the source line for Q307, Q308 and Q309 on and off. The signal output of the VCO is amplified by the buffer amplifier Q310 and divided into two signals which one is amplified by Q312 and the other is done by Q311. The signal from Q312 passes through D306 which is transmit/receive switch, is amplified by Q201 and Q204, and is output from the CN203.

The signal from Q311 passes through the low-pass filter and is applied to IC301 which is PLL frequency synthesizer with VCXO ; X301. The VCXO of which the frequency stability is within 2.0ppm (temperature range of -30 to +60°C) generates 16.8MHz. The PLL-IC consists of three modulus prescaler, fractional divider, reference divider, digital phase comparator with charge pump output.

This PLL-IC is Fractional-N type synthesizer and performs is 40 or 50 or 60kHz reference signal which is eighth of the channel step (5 or 6.25 or 7.5kHz). The input signal from the pins 5 and 8 of the PLL-IC is divided down to the 40 or 50 or 60kHz and compared at digital phase comparator.

The pulsed output signal of the digital phase comparator is applied to the charge pump and transformed into DC signal. The DC signal from the pin 14 of the PLL-IC passes through the active low-pass filter (loop filter), is applied to the VCO and controls to keep the frequency of the VCO.

The serial data (DT, CP, EP) of the microprocessor IC516 is input to the PLL-IC. And PLL lock condition is always monitored by the pin 28 (UL) of IC516.

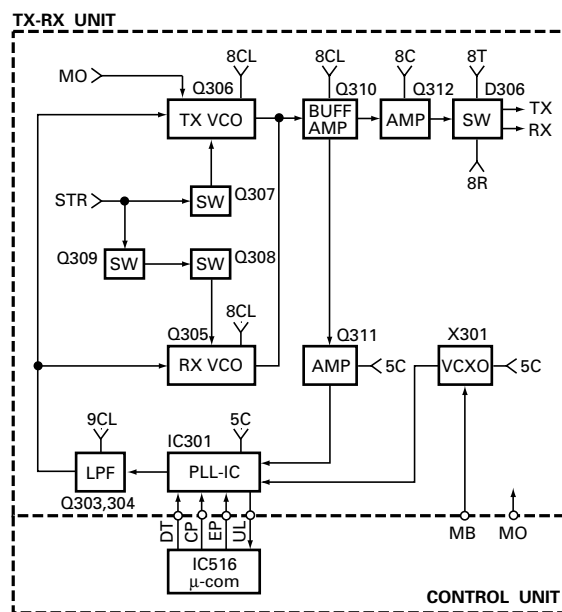

**Fig. 9 VCO/PLL circuit**

## CIRCUIT DESCRIPTION

### 6. Control Circuit

The control unit consists of microprocessor IC and its peripheral circuits. It controls the TX-RX unit and transfers data to and from the control unit. The CPU (IC516) mainly performs the following :

- 1) Switching between transmission and reception according to the PTT signal.
- 2) Reading channel, frequency, and program data from the memory circuit.
- 3) Sending frequency data to the PLL.
- 4) Turning the squelch on and off according to the voltage from the squelch circuit.
- 5) Controlling the audio mute circuit according to input decode data.
- 6) Sending encode data (QT, DQT).
- 7) Sending data to the D/A converter.

#### 6-1. Memory circuit

A flash memory (IC519) with a capacity of 2Mbits contains the transceiver control program for the CPU (IC516) and data such as transceiver channels and operating features.

This program can be easily written from an external devices. Data, such as DTMF memories and operating status, tuning data are programmed into the EEPROM (IC514).

#### 6-2. Shift register

IC517 and IC523 are an interface IC for I/O port expansion. It is used to expand the CPU (IC516) output ports.

#### 6-3. D/A converter

IC512 is used as a conventional semi-fixed-resistor converter. It sets the following :

- 1) RX sensitivity
- 2) Transmission power
- 3) Modulation level
- 4) Audio power
- 5) Frequency

#### 6-4. Power supply circuit

D507 is a protection diode for the excess voltage

- 1) Turning the transceiver on/off with a power switch. Each time you press the power switch, the IC501 output is alternated. The output is feed through Q501, Q503 to turn Q519 on. The power source is always supplied to the IGN terminal. If 24V DC is supplied to the transceiver by mistake, Q502 is turned on then Q503 and Q519 are turned off to protect the transceiver (turned off).
- 2) Turning the transceiver on with a power switch, then turning the transceiver off with the Timed Power Off (TPO) function. POF is controlled by CPU's TPO function. POF is to turn the transceiver off. The POF logic signal is feed through Q507 and Q506 then 8 pin of IC501 to turn the transceiver off.
- 3) Turning the transceiver on with IGN SENS, then turning the transceiver off with TPO function. If IGN is turned on, Q543 and Q542 are turned on then the IC501 detects the change. IC501 outputs the signal to turn Q541 off, then Q503 and Q519 are turned on. When POF is detected by 6 pin of IC501, Q541 is turned on then Q503 and Q519 are turned off.

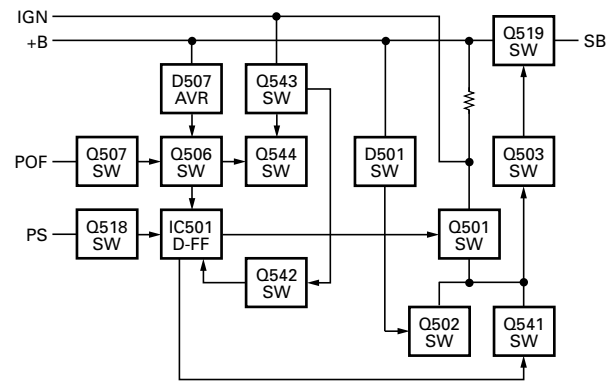

Fig. 10 Power supply circuit

### 7. Signalling Circuit

#### 7-1. Encode

##### • QT, DQT

The CPU (IC516) transmits the encode data selected by the program. The data items are output from CPU pin 34.

The signal from this pin passes through the CR low-pass filter and goes to the summing amplifier (IC510) in the microphone amplifier.

##### • DTMF

The DTMF-encoder (IC511) transmits the encode data. The encode data is passed to the D/A convertor (IC512) for DTMF deviation adjustment, and goes to IC505 in the IDC circuit of the microphone amplifier.

#### 7-2. Decode

##### • QT, DQT

The demodulated signal from CN502 pin 5 is amplified by IC521 and passes through a low-pass filter (IC502) to remove audio components. The signal is input to pin 25 of the CPU. The CPU digitizes this signal, and decodes the signal.

##### • 2 TONE

The demodulated signal from CN502 pin 5 is amplified by IC504 and passes through a high-pass filter (IC518) and a band-elimination filter (IC524) to remove QT and DQT.

This signal is amplified by IC521 and inputs pin 91 of the CPU.

##### • DTMF

The demodulated signal from CN502 pin 5 is amplified by IC504 and passes through a high-pass filter (IC518) and band-elimination filter (IC524) to remove QT and DQT.

This signal inputs pin 1 of the DTMF decoder (IC525).

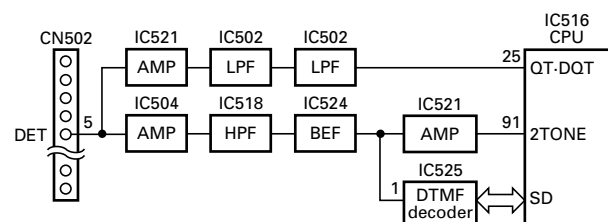

Fig. 11 Decode

# TK-790/(B)/H(B)

## CIRCUIT DESCRIPTION

### 8. Display Unit

The optional display unit (front panel unit) for the TK-790(B)/H(B) comes in two models : KCH-10 and KCH-11

#### 8-1. KCH-10 (Contain : TK-790)

This display unit consists of a CPU (IC4) containing the LCD driver, a reset IC (IC2), 5V AVR (IC1), EEPROM (IC3), and other components.

#### • Encoder

Channels are changed by the rotary encoder (ENC). The up/down pulses from the rotary encoder enter the CPU (IC4), and converted to a serial data signal, and are sent to the control unit.

#### • Power supply

Power is supplied to the CPU by converting SB from the control unit to 5V by IC1. And SB is supplied to the LED for backlight.

#### • CPU (containing LCD driver)

The on/off signals of keys other than the power switch, and the PTT and HOOK signals, are converted to serial data and sent to the control unit. Data is displayed on the 13-segments, 8-digits LCD and 7-segments, 3-digits LCD by the built-in LCD driver.

#### • Dimmer function

From the control of the CPU's DM1/DM2 port, you can switch the LCD/KEY backlight, busy/TX LED, or the optional KMC-28 key backlight as shown in the following table.

Dimmer setting	LCD	KEY	Busy/TX	KMC-28
H	H	ON	ON	ON
M	M	ON	ON	ON
L	L	ON	ON	ON
OFF	OFF	OFF	OFF	OFF

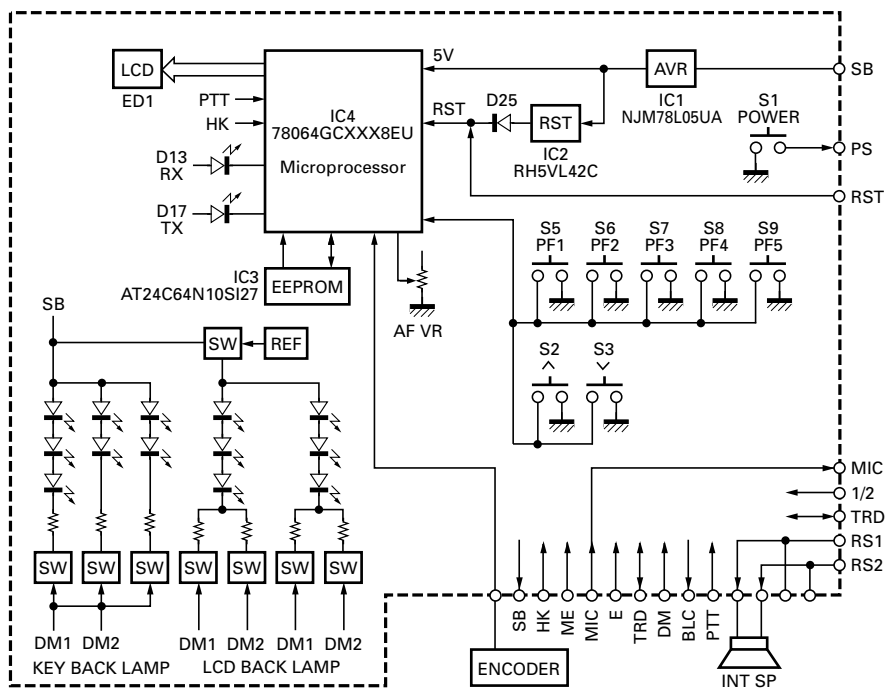

Fig. 12 KCH-10 block diagram

## CIRCUIT DESCRIPTION

### 8-2. KCH-11

This display unit consists of a CPU (IC4) a reset IC (IC2), 5V AVR (IC1), EEPROM (IC3), and other components.

#### • Encoder

Channels are changed by the rotary encoder (ENC). The up/down pulses from the rotary encoder enter the CPU (IC4), and converted to a serial data signal, and are sent to the control unit.

#### • Power supply

Power is supplied to the CPU by converting SB from the control unit to 5V by IC1. And SB is supplied for the LED of backlight.

#### • CPU

The on/off signals of keys other than the power switch, and the PTT and HOOK signals, are converted to serial data and sent to the control unit. Data is displayed on the 14-digits and 3-digits dot matrix alphanumeric display.

#### • Dimmer function

From the control of the CPU's DM1/DM2 port, you can switch the LCD/KEY backlight, busy/TX LED, or the optional KMC-28 key backlight as shown in the following table.

Dimmer setting	LCD	KEY	Busy/TX	KMC-28
H	H	ON	ON	ON
M	M	ON	ON	ON
L	L	ON	ON	ON
OFF	OFF	OFF	OFF	OFF

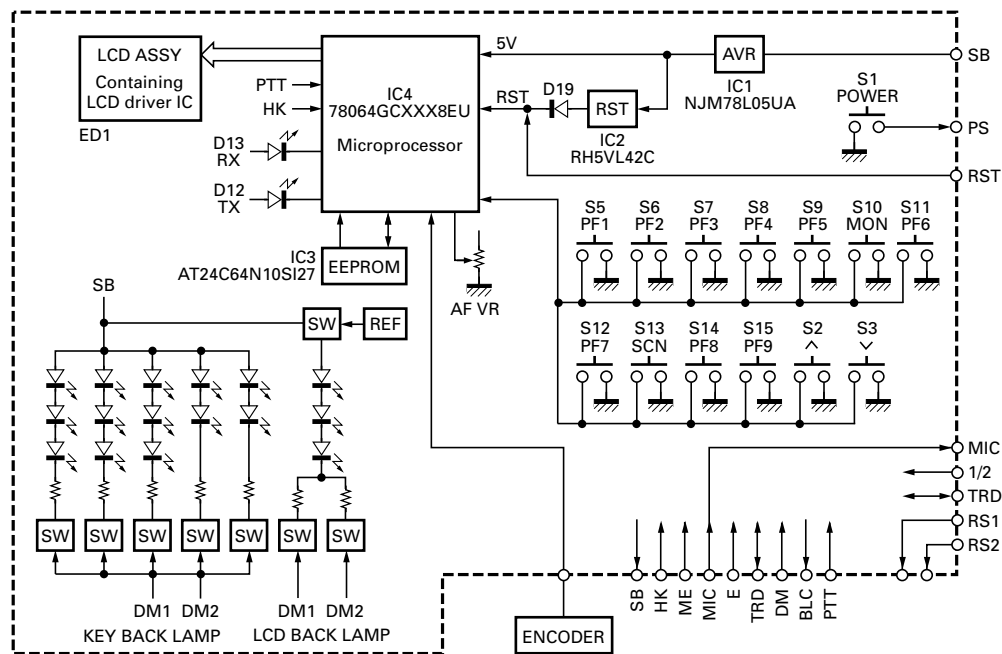

Fig. 13 KCH-11 block diagram

# TK-790/(B)/H(B)

## SEMICONDUCTOR DATA

### Microprocessor : 784214GCXXX8EU (Control Unit IC516)

#### • Terminal function

Pin No.	Pin name	I/O	Action	Pin No.	Pin name	I/O	Action
1	FCLR	O	Modem FCLR	40	RXD1	I	Serial interface RXD
2	CK	O	Common CLOCK	41	TXD1	O	Serial interface TXD
3	EM	O	D/A converter CS	42	STB	O	Modem STB
4	MSKE	O	Modem MSKE	43	EC1	O	Shift register1 (Control) CS
5	DIN	O	Modem DIN	44	EI	O	Shift register (Interface) CS
6	EP	O	PLL LE	45	SEL	I/O	GE-STAR I/O
7	SCL	O	DTMF encoder CLOCK	46	EPT	I	GE-STAR EPT
8	SDT	O	DTMF encoder DATA	47	EMG	O	GE-STAR EMG
9	VDD		+5V	48~71			Flash ROM access port
10,11	X2, X1		X'tal	72	VSS		GND
12	VSS		GND	73~74			Flash ROM access port
13	XT2		Open	75			Flash ROM (4Mbit) access port
14	XT1		GND	76			Not used.
15	RESET		CPU reset	77~78			Flash ROM access port
16	TEST	I	Serial interface TEST	79	POF	O	Timed Power OFF.
17	TRD	I	Modem TRD	80			Not used.
18	RTM	I	Modem RTM	81	VDD		+5V
19	STD	I	DTMF decoder STD	82	EN2	O	D/A converter (Interface) CS
20	EC2	O	Shift register 2 (Control) CS	83	CLK	O	EEPROM CLOCK
21	DT	O	Common DATA	84	SDA	I/O	EEPROM DATA
22	ACK	O	DTMF decoder CLOCK	85	RSV1	O	Reserved
23	AVDD		+5V	86	AI1	I	Acc PF Input 1
24	AVREF0		+5V	87	AI2	I	Acc PF Input 2
25	TI	I	QT/DQT IN	88	AI4	I	Acc PF Input 4
26	RSI	I	RSSI IN	89	AI3	I	Acc PF Input 3
27	ASQ	I	Analog squelch IN	90	AI5	I	Acc PF Input 5
28	UL	I	PLL UNLOCK	91	2TN	I	2tone pulse IN
29	SD	I	DTMF decoder SD	92	KEY	O	TX power SW
30	RDT	I	Modem RDT	93	SQ	O	Acc SQ OUT L : BUSY, H : Not BUSY
31	RSV2	I	Reserved	94	TEST		GND
32	IGN	I	Ignition IN	95	AO1	O	Acc PF Output 1
33	AVSS		GND	96	AO2	O	Acc PF Output 2
34	TO	O	QT/DQT OUT	97	AO3	O	Acc PF Output 3
35	CP	O	PLL CLOCK	98	AO4	O	Acc PF Output 4
36	AVREF1		+5V	99	1/2	I	Deck 1/2 L : Deck 1, H : Deck 2
37	RXD2	I	Acc RXD	100	SFT	O	Beat shift
38	TXD2	O	Acc TXD				
39	ES	O	Shift register (TX/RX) CS				

## SEMICONDUCTOR DATA

## Microprocessor : 78064GCXXX8EU (Display Unit IC4)

## • Terminal function

Pin No.	Pin name	I/O	Action	Pin No.	Pin name	I/O	Action
1	PTT	I	MIC PTT L : ON, H : OFF	74			Not used
2	K5	I	[MON] key L : ON, H : OFF	75	RXD	I	Serial interface RXD
3	K6	I	[PF6] key L : ON, H : OFF	76	TXD	O	Serial interface TXD
4	K7	I	[PF1] key L : ON, H : OFF	77			Not used
5	K8	I	[PF2] key (Full) L : ON, H : OFF	78		-	GND
6	K9	I	[PF3] key (Full) L : ON, H : OFF	79	X2	-	X'tal 4.19MHz
7	K10	I	[PF7] key (Full) L : ON, H : OFF	80	X1	-	X'tal 4.19MHz
8	AVDD	-	+5V	81	VDD	-	+5V
9	AVREF	-	+5V	82,83			Not used
10	RED	O	TX LED (Red) L : ON, H : OFF	84	RST	-	Reset
11	GRN	O	BUSY LED (Green) L : ON, H : OFF	85	END	I	Encoder data
12	E	-	GND	86	K3	I	[GR ^] Key L : ON, H : OFF
13	DM1	O	Backlight (Dimmer)	87	K4	I	[GR v] Key L : ON, H : OFF
14	DM2	O	Backlight (Dimmer)	88	ENI	I	Encoder interrupt
15		I	Not used	89	TEST	I	Serial interface test
16	K11	I	[SCN] key (Full) L : ON, H : OFF	90	AO2	O	Programable AUX output B
17	K12	I	[PF8] key (Full) L : ON, H : OFF	91	AO1	O	Programable AUX output A
18	K13	I	[PF9] key (Full) L : ON, H : OFF	92	AI2	I	Programable AUX input B
19	K1	I	[PF4] key L : ON, H : OFF	93	AI1	I	Programable AUX input A
20	K2	I	[PF5] key L : ON, H : OFF	94	BLC	O	MIC backlight ON/OFF L : ON, H : OFF
21	1/2	I	HEAD 1/2 jumper HEAD 1 : Jumper installed, HEAD 2 : Jumper removed	95,96			Not used
22	B/F	I	Panel type Jumper Basic panel : Jumper installed. Full panel : Jumper removed	97	DM	I	DTMF MIC key pad data input
23~26	COM0~3	O	LCD drive common 0~3	98	HK	I	MIC hook L : ON, H : OFF
27	BIAS		LCD drive bias	99	AVSS	-	GND
28~30	VLC0~2		LCD drive power supply	100	VOL	I	AF volume
31	VSS		GND				
32~67	S0~35	O	LCD drive segment 0~35				
68	S36	O	LCD drive segment 36 (Basic)				
	CE		DOT matrix driver CE (Full)				
69	S37	O	LCD drive segment 37 (Basic)				
	CL		DOT matrix driver CL (Full)				
70	S38	O	LCD drive segment 38 (Basic)				
	DI		DOT matrix driver DI (Full)				
71	S39	O	LCD drive segment 39 (Basic)				
	DO	I	DOT matrix driver DO (Full)				
72	SCK	O	EEPROM serial clock				
73	SDT	I/O	EEPROM serial data				

## Shift Register Output

## • Shift register 1 on control unit (IC523)

Pin No.	Port	Name	Action
4	Q1	PTO	GE-STAR/Scrambler PTO
5	Q2	BC4	Scrambler BC4
6	Q3	BC3	Scrambler BC3
7	Q4	BC2	Scrambler BC2
14	Q5	AC	Scrambler AC
13	Q6	BC1	Scrambler BC1
12	Q7	HR	Acc HR
11	Q8	CMP	Compander H : ON, L : OFF

# TK-790/(B)/H(B)

## SEMICONDUCTOR DATA

### • Shift register 2 on control unit (IC517)

Pin No.	Port	Name	Action
4	Q1	MM	MIC mute H : Mute, L : Unmute
5	Q2	AS	Audio line SW RX BPF↔DE-EMP
6	Q3	DS	DET line SW DET↔RX BPF
7	Q4	AM1	Audio mute 1
14	Q5	RG1	Modem RG1
13	Q6	RG2	Modem RG2
12	Q7	MS	MOD line SW MIC AMP↔RX BPF
11	Q8	AM2	Audio mute 2

### • Shift register on TX-RX (IC201)

Pin No.	Port	Name	Action
4	Q1	STR	TX/RX VCO SW
5	Q2		Not used
6	Q3		Not used
7	Q4		Not used
14	Q5	8R	8R SW
13	Q6	W/N	Wide/Narrow SW H : Narrow, L : Wide
12	Q7		Not used
11	Q8		Not used

### Audio Power Amplifier

#### : TDA8561Q (Control Unit IC522)

#### • Terminal description

Pin No.	Symbol	Description
1	-INV1	Non-inverting input 1
2	GND (S)	Signal ground
3	INV 2	Inverting input 2
4	RR	Supply voltage ripple rejection
5	VP1	Supply voltage
6	OUT 1	Output 1
7	GND1	Power ground 1
8	OUT 2	Output 2
9	NC	Not connected
10	OUT 3	Output 3
11	GND2	Power ground 2
12	OUT 4	Output 4
13	VP2	Supply voltage
14	MODE	Mode select switch input
15	INV 3	Inverting input 3
16	VDIAG	Diagnostic output
17	-INV 4	Non-inverting input 4

### • Block diagram

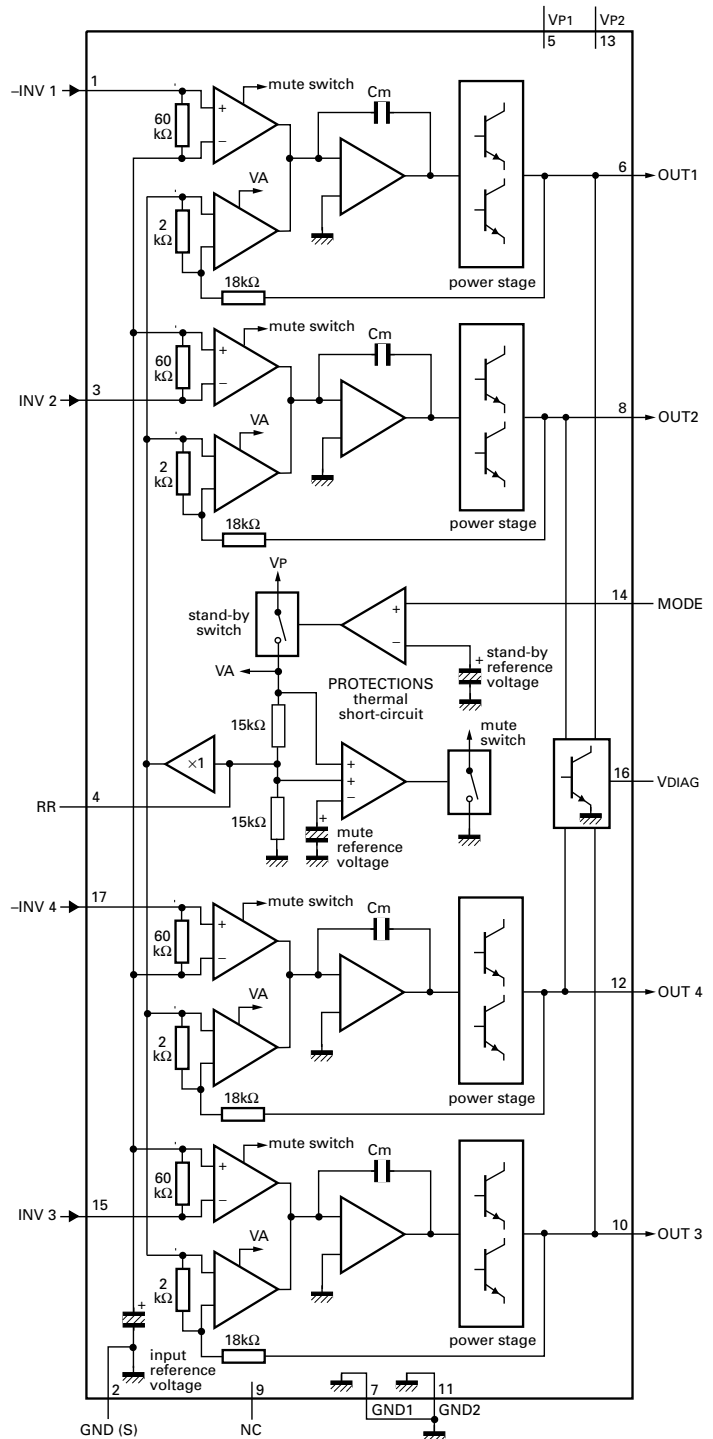

## SEMICONDUCTOR DATA

### Flash ROM : AT29C020-90TI (Control Unit IC519)

• Terminal description

Pin Name	Function
A0~A17	Addresses
$\overline{CE}$	Chip enable
$\overline{OE}$	Output enable
$\overline{WE}$	Write enable
I/O0~I/O7	Data inputs/outputs
NC	No connect

• Block diagram

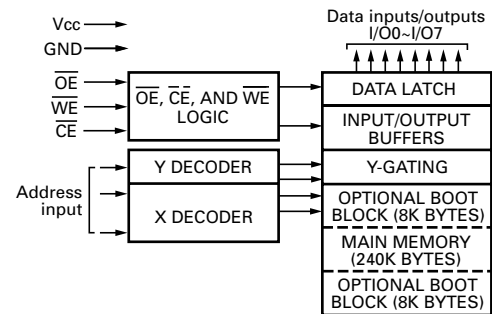

### Power Amplifier : M68702H (Final Unit IC1) TK-790/(B) K type : M68702L (Final Unit IC1) TK-790(B) K2 type

• Equivalent circuit

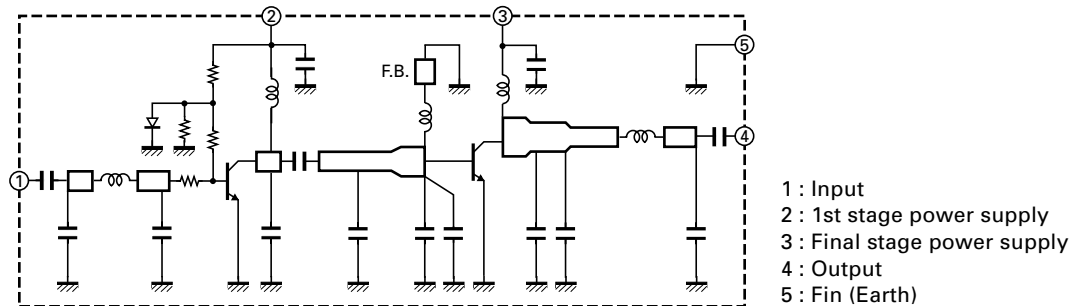

### Final Amplifier : 2SC2782 (Final Unit Q6, Q7) TK-790H(B)

• Absolute maximum ratings

T<sub>c</sub> = 25°C unless otherwise noted

Symbol	Parameter	Conditiona	Rating
V <sub>CB0</sub>	Collector-base voltage		36V
V <sub>EB0</sub>	Emitter-base voltage		4V
V <sub>CE0</sub>	Collector-emitter voltage	R <sub>BE</sub> = ∞	16V
I <sub>c</sub>	Collector current		20A
P <sub>c</sub>	Collector dissipation		220W
T <sub>j</sub>	Junction temperature		175°C
T <sub>stg</sub>	Storage temperature		-65 to 175°C

# TK-790/(B)/H(B)

## DESCRIPTION OF COMPONENTS

### General : TK-790/(B)

Ref. No.	Use/Function	Operation/Condition
IC1	Power amplifier	

### General : TK-790H(B)

Ref. No.	Use/Function	Operation/Condition
IC1	TX drive amplifier	
Q6,7	Final amplifier	

### Final Unit (X45-3560-10) : TK-790H(B)

Ref. No.	Use/Function	Operation/Condition
Q1	DC amplifier	APC controller
Q2	DC switch	
Q3	APC controller	
Q4	DC amplifier	APC controller
Q5	APC comparator	APC controller
Q8	TX/RX switch	On when RX
Q9	TX/RX switch	ON when RX
Q10,11	DC switch	
D1	Forward wave rectification	
D2	Reflected wave rectification	
D3	Combiner	
D4,5	Surge absorption	
D6	Voltage reference	
D7	Protect of reverse connection	

### TX-RX Unit (X57-5610-XX) (A/3)

-10 : TK-790/(B) K    -11 : TK-790(B) K2    -12 : TK-790H(B) K

Ref. No.	Use/Function	Operation/Condition
IC101	FM IC	1, 2 : Oscillator (45.305MHz) 3 : Mixer output    4 : Vcc 5 : IF input (455kHz) 7 : Noise filter output 8 : Noise filter input 9 : DET output (AF OUT) 10 : Quad input 12 : RSSI output 16 : Input (44.85MHz)
IC201	Shift register	
IC202	AVR	Input : 8V    Output : 5V

Ref. No.	Use/Function	Operation/Condition
IC203	AVR	Input : SB    Output : 9V
IC301	PLL IC	1 : CP    2 : DT    3 : EP 4 : Vss    5 : Fin    7 : Vcc 8 : REFin (16.8MHz) 14 : Charge pump output 18 : UL ("H" when lock) 20 : VDD (5V)
Q101	1st amplifier	RX frequency
Q102	IF amplifier	44.85MHz
Q104	Mix local amplifier	(RX frequency + 44.85)MHz
Q105	DC switch	ON when wide
Q106	DC switch	On when narrow
Q107	IF amplifier	44.85MHz
Q108	DC switch	On when wide
Q109	SQL amplifier	(Noise amplifier)
Q201	TX pre-drive amplifier	
Q202	8T switch	8V when TX
Q203	8T switch	On when TX
Q204	TX pre-drive amplifier	
Q205	8R switch	On when RX
Q206	8R switch	8V when RX
Q301	Ripple filter	8CL
Q302	Ripple filter	9CL
Q303,304	Loop filter	
Q305	OSC	RX-VCO
Q306	OSC	TX-VCO
Q307	DC switch	On when TX
Q308	DC switch	On when RX
Q309	DC switch	Off when TX
Q310	Buffer amplifier	
Q311,312	Amplifier	
D101	DC switch	On when TX
D102	BPF tuning	Vari-cap tuning
D103	Noise detector	
D104,105	BPF tuning	Vari-cap tuning
D106~109	IF switch	Wide/Narrow
D201,202	TX pre-drive bias	
D301	Frequency controller	TX-VCO
D302	Frequency controller	RX-VCO
D303	Frequency controller	TX-VCO
D304	Frequency controller	RX-VCO
D305	Modulator	
D306	RF switch	TX/RX
A101	DBM	

## DESCRIPTION OF COMPONENTS

## Control Unit (X57-5610-XX) (B/3)

-10 : TK-790/(B) K -11 : TK-790(B) K2 -12 : TK-790H(B) K

Ref. No.	Use/Function	Operation/Condition
IC501	D FF	
IC502	LPF	
IC503	AVR	Input : SB, Output : 8V
IC504	Audio processor	
IC505	HPF/IDC	
IC506	AVR	Input : 8V, Output : 5V
IC508	Limiter/Buffer amplifier	
IC509	Buffer amplifier	
IC510	Summing amplifier/LPF	
IC511	DTMF encoder	
IC512	D/A converter	
IC513	LPF/Summing amplifier	
IC514	EEPROM	
IC515	Analog switch	
IC516	CPU	
IC517	Shift register	
IC518	Buffer amplifier	
IC519	Flash ROM	
IC520	NOR gate	
IC521	Buffer amplifier/ Amplifier	
IC522	Audio power amplifier	
IC523	Shift register	
IC524	Buffer amplifier/ De-emphasis	
IC525	DTMF decoder	
IC526	Compander amplifier	
Q501	DC switch	
Q502	DC switch	On when 18V or more
Q503	DC switch	On when the power switch on
Q504	Muting switch	MIC mute
Q505	DC switch	
Q506,507	DC switch	Timed power off switch
Q509	DC switch	Off when P/A
Q510	DC switch	Off when EXT SP
Q511	DC switch	Off when INT SP
Q512	DC switch	Off when RX busy
Q513	DC switch	
Q514	Muting switch	On when AF mute
Q516,517	DC switch	On when on signalling code
Q518	DC switch	On when push the power switch
Q519	Power switch	On when the power switch on
Q520	DC switch	On when horn alert
Q522	Beat shift switch	On when beat shift

Ref. No.	Use/Function	Operation/Condition
Q523	DC switch	Serial data inverter
Q524	DC switch	Serial data transmitter
Q525	DC switch	
Q526,527	DC switch	On when compander on
Q528,529	DC switch	On when compander off
Q530~532	DC switch	On when compander on
Q533~540	DC switch	On when output port on
Q541	DC switch	On when timed power off
Q542,543	DC switch	IGN switch
Q544	DC switch	Timed power off switch
D501	Voltage reference	Protection of high voltage
D502	Reverse current prevention	
D503	Surge absorption	
D504	Voltage reference	
D505,506	DC switch	
D507	Voltage reference	
D508	DC switch	
D511	DC switch	
D512	Reverse current prevention	
D513~517	Surge absorption	
D519	Surge absorption	
D521	Surge absorption	
D523,524	Surge absorption	
D526,527	Surge absorption	
D528,529	Reverse current prevention	

## Final Unit (X57-5610-XX) (C/3)

-10 : TK-790/(B) K -11 : TK-790(B) K2

Ref. No.	Use/Function	Operation/Condition
Q1	DC amplifier	APC controller
Q2	APC controller	
Q3,4	DC switch	
Q5	APC comparator	APC controller
Q6	DC switch	
D1	Protection of reverse connection	
D2	Surge absorption	
D3,4	ANT switch	
D5	Forward wave rectification	
D6	Reflected wave rectification	

# TK-790/(B)/H(B)

## DESCRIPTION OF COMPONENTS

**Display Unit (X54-3190-20) : KCH-10**

Ref. No.	Use/Function	Operation/Condition
IC1	AVR	Input : SB Output : 5V
IC2	Reset	
IC3	EEPROM	
IC4	CPU/LCD driver	
Q1	9V AVR	
Q3	DC switch	Dimmer "Hi", "Low" : ON
Q4	DC switch	^ , v key lighting : ON
Q5	DC switch	Dimmer "Hi", "Mid" : ON
Q6	DC switch	Dimmer "Hi", "Low" : ON
Q7	DC switch	Dimmer "Hi", "Mid" : ON
Q9	DC switch	"PF1", "PF2", "PF3" key lighting : ON
Q11	DC switch	"PF4", "PF5" key lighting : ON
Q12,13	TRD switch	
Q14,15	DC switch	On when output port on
D1,2	Surge absorption	
D5	Voltage reference	
D6~11	LCD backlight	
D12	BUSY LED	
D13	TX LED	
D16,17	Surge absorption	
D19~21	Surge absorption	
D24	DC switch	Key lighting : ON
D25	DC switch	

**Display Unit (X54-3200-20) : KCH-11**

Ref. No.	Use/Function	Operation/Condition
IC1	AVR	Input : SB Output : 5V
IC2	Reset	
IC3	EEPROM	
IC4	CPU	
Q1	9V AVR	
Q2	DC switch	^ , v key lighting : ON
Q3	DC switch	Dimmer "Hi", "Low" : ON
Q4	DC switch	"MON", "PF6", "PF7" key lighting : ON
Q5	DC switch	"PF1", "PF2", "PF3" key lighting : ON
Q6	DC switch	Dimmer "Hi", "Mid" : ON
Q7	DC switch	"SCN", "PF8", "PF9" key lighting : ON
Q8	DC switch	"PF4", "PF5" key lighting : ON
Q9,10	TRD switch	
Q14,15	DC switch	On when output port on
D1,2	Surge absorption	
D5	Voltage reference	
D6	BUSY LED	
D7	TX LED	
D11,12	Surge absorption	
D14~16	Surge absorption	
D18	DC switch	Key lighting : ON
D19	DC switch	

## PARTS LIST

\* New Parts.  $\Delta$  indicates safety critical components.

Parts without **Parts No.** are not supplied.

Les articles non mentionnés dans le **Parts No.** ne sont pas fournis.

Teile ohne **Parts No.** werden nicht geliefert.

**L** : Scandinavia

**Y** : PX (Far East, Hawaii)

**Y** : AAFES (Europe)

**K** : USA

**T** : England

**X** : Australia

**P** : Canada

**E** : Europe

**M** : Other Areas

**TK-790**  
**TK-790(B)**

Ref. No.	Address	New parts	Parts No.	Description	Desti-nation	Ref. No.	Address	New parts	Parts No.	Description	Desti-nation
<b>TK-790</b>											
1	3A		A01-2161-02	CABINET (UPPER)		A	2B		N09-2292-05	HEXAGON HEAD SCREW	
2	1A		A01-2162-02	CABINET (LOWER)		B	2A,2B		N32-3006-46	FLAT HEAD MACHINE SCREW	
3	2B	*	A10-1388-11	CHASSIS		C	1A,3B		N33-3006-45	OVAL HEAD MACHINE SCREW	
4	2A	*	A62-0606-13	PANEL ASSY (KCH-10)		D	1A,2A		N35-3006-46	BINDING HEAD MACHINE SCREW	
6	3A,3B		B42-2455-04	STICKER (M4X8MAX)		E	2B		N67-3008-46	PAN HEAD SEMS SCREW W	
7	1J		B46-0470-00	WARRANTY CARD ACSY		-			N87-2605-46	BRAZIER HEAD TAPTITE SCREW (KCH-10)	
8	1J	*	B62-0970-10	INSTRUCTION MANUAL		G	2A,3B		N87-2606-46	BRAZIER HEAD TAPTITE SCREW	
-		*	B72-1450-24	MODEL NAME PLATE		-			N87-2608-46	BRAZIER HEAD TAPTITE SCREW (KCH-10)	
11	2B		E04-0167-05	RF COAXIAL PECEPTACLE (M)		J	1A		N87-2612-46	BRAZIER HEAD TAPTITE SCREW	
12	1I	*	E30-3318-15	DC CORD ASSY ACSY		-			N87-3006-46	BRAZIER HEAD TAPTITE SCREW (KCH-10)	
13	2A		E31-3269-05	LEAD WIRE WITH MINIPIN PLUG (RA/DO)		L	1B,2B		N87-3008-46	BRAZIER HEAD TAPTITE SCREW	
14	2B		E37-0708-05	LEAD WIRE WITH CONNECTOR (ACC:9P)		59	2I		N99-0321-05	SCREW SET ACSY	
15	1B		E37-0728-05	LEAD WIRE WITH CONNECTOR (DC:2P)		-			T07-0265-05	SPEAKER (KCH-10)	
16	1B,2I		E37-0733-05	SHORT PLUG (SP) ACSY		62	1I	*	T91-0587-25	MICROPHONE (KMC-27) ACSY	
17	2B	*	E37-0772-15	LEAD WIRE WITH CONNECTOR (D-SUB:25P)		<b>TK-790(B)</b>					
18	3A		E37-0776-05	FLAT CABLE (CONT-TX:18P)		1	3A		A01-2161-02	CABINET (UPPER)	
-			E37-0787-05	LEAD WIRE WITH CONNECTOR (KCH-10)		2	1A		A01-2162-02	CABINET (LOWER)	
21	2I		F05-1537-05	FUUSE (BLADE) (15A/32V) ACSY		3	2B	*	A10-1388-11	CHASSIS	
23	2B		F09-0445-05	CAP (D-SUB)		6	3A,3B		B42-2455-04	STICKER (M4X8 MAX)	
24	1B		F10-1479-03	SHIELDING PLATE (FINAL)		7	1J		B46-0470-00	WARRANTY CARD ACSY	
22	2I		F29-0472-04	INSULATING COVER ACSY		8	1J	*	B62-0970-10	INSTRUCTION MANUAL	
26	2A		G02-0599-04	FLAT SPRING (APC)		-		*	B72-1450-24	MODEL NAME PLATE	K
27	3A		G02-0709-04	FLAT SPRING (AUDIO AMP)		-		*	B72-1452-24	MODEL NAME PLATE	K2
28	3A		G02-0715-04	FLAT SPRING (AVR)		11	2B		E04-0167-05	RF COAXIAL PECEPTACLE (M)	
29	2B		G53-0712-03	PACKING (DC,ACC)		13	2A		E31-3269-05	LEAD WIRE WITH MINIPIN PLUG (RA/DO)	
-			G53-0838-03	PACKING (KCH-10:PANEL ASSY)		14	2B		E37-0708-05	LEAD WIRE WITH CONNECTOR (ACC:9P)	
-			G53-0839-14	PACKING (KCH-10:SP)		15	1B		E37-0728-05	LEAD WIRE WITH CONNECTOR (DC:2P)	
32	3B		G53-0869-03	PACKING (CABINET UPPER)		16	1B,2I		E37-0733-05	SHORT PLUG (SP) ACSY	
33	1A		G53-0870-03	PACKING (CABINET LOWER)		17	2B	*	E37-0772-15	LEAD WIRE WITH CONNECTOR (D-SUB:25P)	
-		*	G53-1523-04	PACKING (KCH-10:VOL)		18	3A		E37-0776-05	FLAT CABLE (CONT-TX:18P)	
36	2J		H10-6621-02	POLYSTYRENE FOAMED FIXTURE		23	2B		F09-0445-05	CAP (D-SUB)	
35	1J		H11-0896-04	POLYSTYRENE FOAMED BOARD		24	1B		F10-1479-03	SHIELDING PLATE (FINAL)	
38	1I		H12-1403-04	PACKING FIXTURE		22	2I		F29-0472-04	INSULATING COVER ACSY	
39	2J		H13-1066-04	CARTON BOARD		26	2A		G02-0599-04	FLAT SPRING (APC)	
40	2I		H25-0029-04	PROTECTION BAG (60/110/0.07)		27	3A		G02-0709-04	FLAT SPRING (AUDIO AMP)	
42	2I		H25-0103-04	PROTECTION BAG (125/250/0.07)		28	3A		G02-0715-04	FLAT SPRING (AVR)	
43	2I		H25-0117-04	PROTECTION BAG (80/250/0.07)		29	2B		G53-0712-03	PACKING (DC,ACC)	
44	1J		H25-0194-04	PROTECTION BAG (280/400/0.07)		32	3B		G53-0869-03	PACKING (CABINET UPPER)	
41	2I	*	H25-2063-04	PROTECTION BAG (80/120/0.03)		33	1A		G53-0870-03	PACKING (CABINET LOWER)	
45	3J		H52-1227-02	ITEM CARTON CASE		36	2J		H10-6621-02	POLYSTYRENE FOAMED FIXTURE	
46	2I		J19-1584-05	HOLDER (MIC) ACSY		37	2J		H11-0892-04	POLYSTYRENE FOAMED BOARD	
47	1B		J21-8346-04	HARDWARE FIXTURE (DC,ACC)		35	1J		H11-0896-04	POLYSTYRENE FOAMED BOARD	
-		*	J21-8417-04	HARDWARE FIXTURE (KCH-10:MIC CONNECTOR)		38	1I		H12-1403-04	PACKING FIXTURE	
48	2I		J29-0422-13	BRACKET ACSY		39	2J		H13-1066-04	CARTON BOARD	
-			J39-0625-04	SPACER (KCH-10:TX-BUSY)		42	2I		H25-0103-04	PROTECTION BAG (125/250/0.07)	
50	2I		J61-0307-05	BAND ACSY		44	1J		H25-0194-04	PROTECTION BAG (280/400/0.07)	
-			K29-4664-04	KNOB (KCH-10:VOL,UP/DOWN)		41	2I	*	H25-2063-04	PROTECTION BAG (80/120/0.03)	
53	2I		K29-4704-04	KNOB ACSY		45	3J		H52-1228-12	ITEM CARTON CASE	
-			K29-5251-12	KEY TOP (KCH-10)		47	1B		J21-8346-04	HARDWARE FIXTURE (DC,ACC)	
55	2I		K29-5276-03	KNOB ACSY							
56	2I		K29-5277-03	KNOB ACSY							
57	2I		K29-5305-03	KNOB ACSY							

# TK-790/(B)/H(B)

## PARTS LIST

TK-790(B)  
TX-RX UNIT (X57-5610-XX) : TK-790/(B)

Ref. No.	Address	New parts	Parts No.	Description	Destination	Ref. No.	Address	New parts	Parts No.	Description	Destination
50	2I		J61-0307-05	BAND ACSY		C102,103			CC73GCH1H220J	CHIP C 22PF J	
A	2B		N09-2292-05	HEXAGON HEAD SCREW		C104			CC73GCH1H180J	CHIP C 18PF J	
C	1A,3B		N33-3006-45	OVAL HEAD MACHINE SCREW		C105			CC73GCH1H101J	CHIP C 100PF J	
D	1A,2A		N35-3006-46	BINDING HEAD MACHINE SCREW		C106			CK73GB1H103K	CHIP C 0.010UF K	
E	2B		N67-3008-46	PAN HEAD SEMS SCREW W		C107			CC73GCH1H101J	CHIP C 100PF J	
G	2A,3B		N87-2606-46	BRAZIER HEAD TAPTITE SCREW		C108			CC73GCH1H100D	CHIP C 10PF D	
J	1A		N87-2612-46	BRAZIER HEAD TAPTITE SCREW		C110			CC73GCH1H100D	CHIP C 10PF D	K
L	1B,2B		N87-3008-46	BRAZIER HEAD TAPTITE SCREW		C110			CC73GCH1H150J	CHIP C 15PF J	K2
59	2I		N99-0365-05	SCREW SET ACSY		C111			CC73GCH1H020C	CHIP C 2.0PF C	
						C112			CK73GB1H103K	CHIP C 0.010UF K	
<b>TX-RX UNIT (X57-5610-XX) -10 : TK-790/(B) K -11 : TK-790(B) K2</b>						C113			CK73GB1H102K	CHIP C 1000PF K	
C1			CK73GB1H102K	CHIP C 1000PF K		C114			CC73GCH1H100D	CHIP C 10PF D	K
C2			C92-0747-05	ELECTRO 33UF 25WV		C114			CC73GCH1H150J	CHIP C 15PF J	K2
C3			C92-0721-05	ELECTRO 330UF 25WV		C116			CC73GCH1H020C	CHIP C 2.0PF C	
C4			CK73FB1E104K	CHIP C 0.10UF K		C117			CC73GCH1H680J	CHIP C 68PF J	
C5			CK73FB1H472K	CHIP C 4700PF K		C118			CC73GCH1H080D	CHIP C 8.0PF D	K
C6			C92-0721-05	ELECTRO 330UF 25WV		C118			CC73GCH1H120J	CHIP C 12PF J	K2
C7			CK73FB1H102K	CHIP C 1000PF K		C119			CC73GCH1H180J	CHIP C 18PF J	
C8			CK73GB1H102K	CHIP C 1000PF K		C120			CC73GCH1H120J	CHIP C 12PF J	
C9			C92-0747-05	ELECTRO 33UF 25WV		C121			CC73GCH1H101J	CHIP C 100PF J	
C10			CK73FB1E104K	CHIP C 0.10UF K		C123			CC73GCH1H221J	CHIP C 220PF J	
C11			CK73FB1E103K	CHIP C 0.010UF K		C124			CC73GCH1H330J	CHIP C 33PF J	
C12			CK73GB1H102K	CHIP C 1000PF K		C125			CK73GB1H103K	CHIP C 0.010UF K	
C13			C92-0724-05	ELECTRO 10UF 50WV		C126			CC73GCH1H150J	CHIP C 15PF J	
C14			CK73FB1H472K	CHIP C 4700PF K		C127			CC73GCH1H151J	CHIP C 150PF J	
C15			CK73FB1H102K	CHIP C 1000PF K		C128			CC73GCH1H030C	CHIP C 3.0PF C	
C16			C93-0561-05	CHIP C 12PF J		C129			CC73GCH1H101J	CHIP C 100PF J	
C17			C92-0725-05	ELECTRO 10UF 35WV		C130			CC73GCH1H270J	CHIP C 27PF J	
C18			C92-0720-05	ELECTRO 100UF 25WV		C131			CK73GB1H102K	CHIP C 1000PF K	
C19			C93-0562-05	CHIP C 15PF J		C132			CC73GCH1H030C	CHIP C 3.0PF C	
C20,21			CK73GB1H102K	CHIP C 1000PF K		C133			CC73GCH1H270J	CHIP C 27PF J	
C22			C93-0563-05	CHIP C 18PF J	K	C134,135			CK73GB1H103K	CHIP C 0.010UF K	
C22			C93-0564-05	CHIP C 22PF J	K2	C138-140			CC73GCH1H030C	CHIP C 3.0PF C	
C23,24			CK73GB1H102K	CHIP C 1000PF K		C141			CC73GCH1H040C	CHIP C 4.0PF C	
C25			CK73FB1H102K	CHIP C 1000PF K		C143			CK73GB1H102K	CHIP C 1000PF K	
C26			C93-0603-05	CHIP C 1000PF K		C144			CC73GCH1H101J	CHIP C 100PF J	
C27,28			CK73GB1H102K	CHIP C 1000PF K		C145,146			CC73GCH1H030C	CHIP C 3.0PF C	
C29			C93-0562-05	CHIP C 15PF J	K	C147			CC73FCH1H090D	CHIP C 9.0PF D	
C29			C93-0563-05	CHIP C 18PF J	K2	C147			CC73FCH1H120J	CHIP C 12PF J	K
C30			C93-0566-05	CHIP C 33PF J		C148			CK73GB1H102K	CHIP C 1000PF K	K2
C31			CC73FCH1H150J	CHIP C 15PF J		C151,152			CK73GB1H103K	CHIP C 0.010UF K	
C32			CC73GCH1H471J	CHIP C 470PF J		C153,154			CK73GB1H102K	CHIP C 1000PF K	
C33			C93-0560-05	CHIP C 10PF D	K	C155			CC73GCH1H100D	CHIP C 10PF D	
C33			C93-0563-05	CHIP C 18PF J	K2	C156			CK73FB1E104K	CHIP C 0.10UF K	
C34			CK73GB1H102K	CHIP C 1000PF K		C157			CC73GCH1H090D	CHIP C 9.0PF D	
C36			CC73FCH1H180J	CHIP C 18PF J	K	C158			CC73GCH1H101J	CHIP C 100PF J	
C36			CC73FCH1H220J	CHIP C 22PF J	K2	C159			CC73GCH1H220J	CHIP C 22PF J	
C37			CK73FB1H102K	CHIP C 1000PF K		C160			CK73GB1H102K	CHIP C 1000PF K	
C38,39			CK73GB1H102K	CHIP C 1000PF K		C161-163			CK73GB1H103K	CHIP C 0.010UF K	
C40			C93-0563-05	CHIP C 18PF J	K2	C165			C92-0560-05	CHIP-TAN 10UF 6.3WV	
C40			C93-0564-05	CHIP C 22PF J	K	C166			CC73GCH1H080D	CHIP C 8.0PF D	
C41			C93-0557-05	CHIP C 7.0PF D	K	C167			CC73GCH1H270J	CHIP C 27PF J	
C41			C93-0560-05	CHIP C 10PF D	K2	C168			CK73FB1E104K	CHIP C 0.10UF K	
C42			C93-0561-05	CHIP C 12PF J	K	C169			CK73GB1H103K	CHIP C 0.010UF K	
C42			C93-0563-05	CHIP C 18PF J	K2	C170,171			CC73GCH1H221J	CHIP C 220PF J	
C101			CK73GB1H103K	CHIP C 0.010UF K		C172			CK73GB1H472K	CHIP C 4700PF K	
						C173			CK73GB1H103K	CHIP C 0.010UF K	
						C174			CK73FB1E104K	CHIP C 0.10UF K	
						C175			CK73GB1C333K	CHIP C 0.033UF K	
						C176			C92-0003-05	CHIP-TAN 0.47UF 25WV	

## PARTS LIST

TX-RX UNIT (X57-5610-XX) : TK-790/(B)

Ref. No.	Address	New parts	Parts No.	Description	Desti-nation	Ref. No.	Address	New parts	Parts No.	Description	Desti-nation
C177			CK73GB1H102K	CHIP C 1000PF K		C328			CC73GCH1H180G	CHIP C 18PF G	K
C178			CK73GB1H103K	CHIP C 0.010UF K		C328			CC73GCH1H270J	CHIP C 27PF J	K2
C179-182			CC73GCH1H470J	CHIP C 47PF J		C329			CK73GB1H102K	CHIP C 1000PF K	
C183-185			CC73GCH1H150J	CHIP C 15PF J		C330			CC73GCH1HR75C	CHIP C 0.75PF C	
C186			CC73GCH1H270J	CHIP C 27PF J	K2	C331			CC73GCH1H150J	CHIP C 15PF J	K
C186			CC73GCH1H330J	CHIP C 33PF J	K	C331			CC73GCH1H180J	CHIP C 18PF J	K2
C187,188			CC73GCH1H120J	CHIP C 12PF J		C332			CK73FB1C474K	CHIP C 0.47UF K	
C189			CK73GB1E223K	CHIP C 0.022UF K		C333			CC73GCH1H150J	CHIP C 15PF J	K
C190			CK73GB1H102K	CHIP C 1000PF K		C333			CC73GCH1H180J	CHIP C 18PF J	K2
C191			CK73GB1E223K	CHIP C 0.022UF K		C334,335			CC73GCH1H120J	CHIP C 12PF J	K
C192			CK73FB1C334K	CHIP C 0.33UF K		C334,335			CC73GCH1H150J	CHIP C 15PF J	K2
C193			CK73GB1H102K	CHIP C 1000PF K		C336			CC73GCH1H150J	CHIP C 15PF J	K
C194			C92-0560-05	CHIP-TAN 10UF 6.3WV		C336			CC73GCH1H180J	CHIP C 18PF J	K2
C195			CK73GB1H102K	CHIP C 1000PF K		C337-339			CK73GB1H102K	CHIP C 1000PF K	
C201			CK73GB1H471K	CHIP C 470PF K		C340,341			CC73GCH1H020C	CHIP C 2.0PF C	
C202			CC73GCH1H101J	CHIP C 100PF J		C342,343			CK73GB1H102K	CHIP C 1000PF K	
C203-205			CK73GB1H102K	CHIP C 1000PF K		C344			CC73GCH1H100D	CHIP C 10PF D	K
C206			CK73GB1H103K	CHIP C 0.010UF K		C344			CC73GCH1H150J	CHIP C 15PF J	K2
C207			C92-0044-05	CHIP-ELE 47UF 10WV		C345-349			CK73GB1H102K	CHIP C 1000PF K	
C208			CK73GB1H102K	CHIP C 1000PF K		C350			CC73GCH1H470J	CHIP C 47PF J	
C209			C92-0023-05	CHIP-ELE 1.0UF 50WV		C351-355			CK73GB1H102K	CHIP C 1000PF K	
C210			CK73GB1H102K	CHIP C 1000PF K		C356			C92-0606-05	CHIP-TAN 4.7UF 10WV	
C211			CC73GCH1H270J	CHIP C 27PF J		C357			C92-0560-05	CHIP-TAN 10UF 6.3WV	
C213,214			CK73GB1H102K	CHIP C 1000PF K		C358			CK73GB1H102K	CHIP C 1000PF K	
C215			CK73FB1E104K	CHIP C 0.10UF K		C359			CC73GCH1H100D	CHIP C 10PF D	K
C216			CK73GB1C473K	CHIP C 0.047UF K		C359			CC73GCH1H150J	CHIP C 15PF J	K2
C217			C92-0008-05	CHIP-TAN 3.3UF 16WV		C360			CC73GCH1H050C	CHIP C 5.0PF C	
C218,219			CK73GB1H102K	CHIP C 1000PF K		C361			CK73FB1C474K	CHIP C 0.47UF K	
C220			CC73FCH1H220J	CHIP C 22PF J		C362			CC73GCH1H270J	CHIP C 27PF J	
C221			CK73GB1H102K	CHIP C 1000PF K		C363,364			CC73GCH1H030C	CHIP C 3.0PF C	
C222			C92-0044-05	CHIP-ELE 47UF 10WV		C365,366			CC73GCH1H150J	CHIP C 15PF J	
C223			CK73GB1H102K	CHIP C 1000PF K		C370			CK73GB1H102K	CHIP C 1000PF K	
C224			CK73FB1E104K	CHIP C 0.10UF K		C371			CK73FB1H473K	CHIP C 0.047UF K	
C225-227			CK73GB1H102K	CHIP C 1000PF K		C501			CC73GCH1H101J	CHIP C 100PF J	
C301,302			CK73GB1H102K	CHIP C 1000PF K		C524			CK73GB1H102K	CHIP C 1000PF K	
C303			CK73GB1H103K	CHIP C 0.010UF K		C525			CK73FB1E683K	CHIP C 0.068UF K	
C304			CK73FB1E104K	CHIP C 0.10UF K		C526,527			CK73GB1H471K	CHIP C 470PF K	
C305			CK73GB1H102K	CHIP C 1000PF K		C528			CC73GCH1H101J	CHIP C 100PF J	
C306,307			CK73GB1H103K	CHIP C 0.010UF K		C529			C92-0585-05	CHIP-TAN 4.7UF 16WV	
C308,309			CK73FB1E104K	CHIP C 0.10UF K		C530			CK73GB1E123K	CHIP C 0.012UF K	
C310			C92-0633-05	CHIP-TAN 22UF 10WV		C531			C92-0560-05	CHIP-TAN 10UF 6.3WV	
C311			C90-4016-05	ELECTRO 47UF 16WV		C532			CK73GB1H222K	CHIP C 2200PF K	
C312			C92-0001-05	CHIP C 0.1UF 35WV		C533			C92-0560-05	CHIP-TAN 10UF 6.3WV	
C313			C92-1341-05	ELECTRO 100UF 16WV		C534			CK73FB1E104K	CHIP C 0.10UF K	
C314			C90-4016-05	ELECTRO 47UF 16WV		C535			C92-0560-05	CHIP-TAN 10UF 6.3WV	
C315			CC73GCH1H100D	CHIP C 10PF D	K	C536,537			CK73FB1E104K	CHIP C 0.10UF K	
C315			CC73GCH1H150J	CHIP C 15PF J	K2	C538			CK73GB1E223K	CHIP C 0.022UF K	
C316,317			CK73GB1H103K	CHIP C 0.010UF K		C539			CC73GCH1H470J	CHIP C 47PF J	
C318,319			C92-0514-05	CHIP-TAN 2.2UF 10WV		C540			CK73FB1E104K	CHIP C 0.10UF K	
C320			CK73FB1E224K	CHIP C 0.22UF K		C541			CK73GB1H102K	CHIP C 1000PF K	
C321			C92-0003-05	CHIP-TAN 0.47UF 25WV		C542			CK73FB1E104K	CHIP C 0.10UF K	
C322			CK73GB1H102K	CHIP C 1000PF K		C543			CK73GB1H102K	CHIP C 1000PF K	
C323			CC73GCH1H240J	CHIP C 24PF J	K	C544			CC73GCH1H121J	CHIP C 120PF J	
C323			CC73GCH1H390J	CHIP C 39PF J	K2	C545			CK73GB1E103K	CHIP C 0.010UF K	
C324			CK73GB1H102K	CHIP C 1000PF K		C546			CK73FB1E104K	CHIP C 0.10UF K	
C325			CC73GCH1H360J	CHIP C 36PF J	K	C547			CK73GB1E223K	CHIP C 0.022UF K	
C325			CC73GCH1H390J	CHIP C 39PF J	K2	C548			C92-0507-05	CHIP-TAN 4.7UF 6.3WV	
C326			CC73GCH1H050C	CHIP C 5.0PF C	K	C549			CK73GB1H222K	CHIP C 2200PF K	
C326			CC73GCH1H070D	CHIP C 7.0PF D	K2	C550			CK73FB1E104K	CHIP C 0.10UF K	
C327			CC73GCH1H470J	CHIP C 47PF J		C551			CK73FB1E333K	CHIP C 0.033UF K	

# TK-790/(B)/H(B)

## PARTS LIST

TX-RX UNIT (X57-5610-XX) : TK-790/(B)

Ref. No.	Address	New parts	Parts No.	Description	Destination	Ref. No.	Address	New parts	Parts No.	Description	Destination
C552			CC73GCH1H470J	CHIP C 47PF J		C626			C92-0004-05	CHIP-TAN 1.0UF 16WV	
C553,554			CK73FB1E104K	CHIP C 0.10UF K		C627,628			CK73FB1E104K	CHIP C 0.10UF K	
C555			CK73GB1H102K	CHIP C 1000PF K		C629,630			CK73GB1H102K	CHIP C 1000PF K	
C557			CK73GB1E223K	CHIP C 0.022UF K		C631			CC73GCH1H101J	CHIP C 100PF J	
C558			C92-0507-05	CHIP-TAN 4.7UF 6.3WV		C632-639			CK73GB1H102K	CHIP C 1000PF K	
C559			C92-0036-05	CHIP-ELE 4.7UF 16WV		C640			C92-0560-05	CHIP-TAN 10UF 6.3WV	
C562			CK73GB1E103K	CHIP C 0.010UF K		C641,642			CK73FB1E104K	CHIP C 0.10UF K	
C563			CK73GB1H102K	CHIP C 1000PF K		C666-680			CC73GCH1H101J	CHIP C 100PF J	
C565			C92-0003-05	CHIP-TAN 0.47UF 25WV		C681			CK73GB1H102K	CHIP C 1000PF K	
C566			CC73GCH1H100D	CHIP C 10PF D		C682,683			CC73GCH1H101J	CHIP C 100PF J	
C567			CK73GB1E223K	CHIP C 0.022UF K		C684			CK73GB1H102K	CHIP C 1000PF K	
C568			CK73GB1H102K	CHIP C 1000PF K		C685			CC73GCH1H101J	CHIP C 100PF J	
C570			C92-0036-05	CHIP-ELE 4.7UF 16WV		C686			CK73GB1H102K	CHIP C 1000PF K	
C571			C92-0585-05	CHIP-TAN 4.7UF 16WV		C687			CK73GB1E103K	CHIP C 0.010UF K	
C572,573			CC73GCH1H030C	CHIP C 3.0PF C		C688,689			CC73GCH1H101J	CHIP C 100PF J	
C574			CK73GB1H472K	CHIP C 4700PF K		C690			CK73FB1E104K	CHIP C 0.10UF K	
C575			C92-0628-05	CHIP-TAN 10UF 10WV		C691,692			CC73GCH1H101J	CHIP C 100PF J	
C576			CC73GCH1H470J	CHIP C 47PF J		C693			CK73GB1E103K	CHIP C 0.010UF K	
C578			C92-0507-05	CHIP-TAN 4.7UF 6.3WV		C694			C92-0633-05	CHIP-TAN 22UF 10WV	
C579			CK73GB1H472K	CHIP C 4700PF K		C695			CC73GCH1H101J	CHIP C 100PF J	
C580-582			CK73GB1H102K	CHIP C 1000PF K		C696			C92-0628-05	CHIP-TAN 10UF 10WV	
C583			C92-0546-05	CHIP-TAN 68UF 6.3WV		C697			CK73GB1E103K	CHIP C 0.010UF K	
C584			CK73FB1E104K	CHIP C 0.10UF K		C698-700			C92-0560-05	CHIP-TAN 10UF 6.3WV	
C585			CC73FCH1H751J	CHIP C 750PF J		C701			C92-0566-05	CHIP-TAN 10UF 6.3WV	
C586			CC73GCH1H180J	CHIP C 18PF J		C703-705			CK73FB1E104K	CHIP C 0.10UF K	
C587			CK73GB1H122K	CHIP C 1200PF K		C706			C92-0507-05	CHIP-TAN 4.7UF 6.3WV	
C588			CC73GCH1H070D	CHIP C 7.0PF D		C707			CC73GCH1H560J	CHIP C 56PF J	
C589			CC73GCH1H181J	CHIP C 180PF J		C708			CK73FB1E104K	CHIP C 0.10UF K	
C590			CK73GB1H332K	CHIP C 3300PF K		C709			CC73GCH1H560J	CHIP C 56PF J	
C591			CC73GCH1H180J	CHIP C 18PF J		C710			CK73GB1E123K	CHIP C 0.012UF K	
C592			CK73GB1H102K	CHIP C 1000PF K		C711			CC73GCH1H101J	CHIP C 100PF J	
C593			C92-0633-05	CHIP-TAN 22UF 10WV		C712			CK73GB1E473J	CHIP C 0.047UF J	
C594			CK73GB1E103K	CHIP C 0.010UF K		TC301,302			C05-0393-05	CERAMIC TRIMMER CAP (8PF)	
C595-597			CK73GB1H102K	CHIP C 1000PF K		CN1			E04-0154-05	PIN SOCKET	
C598,599			CK73FB1E104K	CHIP C 0.10UF K		CN2			E23-0902-05	TERMINAL	
C600			C92-0507-05	CHIP-TAN 4.7UF 6.3WV		CN3			E04-0154-05	PIN SOCKET	
C601			CK73GB1H102K	CHIP C 1000PF K		CN4			E23-1118-05	TERMINAL	
C602			CK73GB1H562K	CHIP C 5600PF K		CN101			E04-0154-05	PIN SOCKET	
C603			CK73GB1H102K	CHIP C 1000PF K		CN102,103			E40-5538-05	PIN ASSY	
C604,605			CK73GB1H562K	CHIP C 5600PF K		CN104			E04-0154-05	PIN SOCKET	
C606			C92-0507-05	CHIP-TAN 4.7UF 6.3WV		CN201			E40-5752-05	PIN ASSY	
C607			CK73GB1H102K	CHIP C 1000PF K		CN202			E40-5978-05	FLAT CABLE CONNECTOR	
C608			CK73GB1H332J	CHIP C 3300PF J		CN203			E04-0154-05	PIN SOCKET	
C609			CK73GB1H272J	CHIP C 2700PF J		CN501			E40-5703-05	PIN ASSY	
C610			CK73FB1E104K	CHIP C 0.10UF K		CN504			E40-5661-05	PIN ASSY SOCKET	
C611			CK73GB1H272J	CHIP C 2700PF J		CN505			E40-5960-05	PIN ASSY	
C612			C92-1341-05	ELECTRO 100UF 16WV		CN506			E40-5066-05	PIN ASSY	
C613			C92-0040-05	CHIP-ELE 47UF 16WV		CN507			E40-5751-05	PIN ASSY	
C614			CK73GB1H102K	CHIP C 1000PF K		CN508			E40-5701-05	PIN ASSY	
C615			CK73GB1H272J	CHIP C 2700PF J		W1			E37-0705-05	LEAD WIRE WITH CONNECTOR	
C616			CK73GB1E103K	CHIP C 0.010UF K		W2			E37-0704-05	LEAD WIRE WITH CONNECTOR	
C617			CK73FB1E104K	CHIP C 0.10UF K		W501			E37-0707-05	LEAD WIRE WITH CONNECTOR	
C618			CK73GB1H272J	CHIP C 2700PF J		A102			F10-2278-04	SHIELDING PLATE (MCF)	
C619			C92-0721-05	ELECTRO 330UF 25WV		F501			F53-0128-05	FUSE (0.5A)	
C620			CK73GB1E103K	CHIP C 0.010UF K		F502			F53-0108-05	FUSE (1.8A)	
C621			CK73FB1E104K	CHIP C 0.10UF K		CF101			L72-0916-05	CERAMIC FILTER (455KHZ)	
C622			CK73GB1H102K	CHIP C 1000PF K		CF102			L72-0939-05	CERAMIC FILTER (455KHZ)	
C623			C92-0040-05	CHIP-ELE 47UF 16WV		CF103			L72-0916-05	CERAMIC FILTER (455KHZ)	
C624			CK73GB1H102K	CHIP C 1000PF K		CF104			L72-0939-05	CERAMIC FILTER (455KHZ)	
C625			CK73GB1E103K	CHIP C 0.010UF K							

## PARTS LIST

TX-RX UNIT (X57-5610-XX) : TK-790/(B)

Ref. No.	Address	New parts	Parts No.	Description	Desti-nation	Ref. No.	Address	New parts	Parts No.	Description	Desti-nation
L1			L34-4519-05	AIR-CORE COIL		R12			RK73FB2A101J	CHIP R 100 J 1/10W	
L2			L34-4523-05	AIR-CORE COIL		R13			RK73GB1J223J	CHIP R 22K J 1/16W	
L3-5			L34-4520-05	AIR-CORE COIL		R14			RK73GB1J102J	CHIP R 1.0K J 1/16W	
L6			L34-4523-05	AIR-CORE COIL		R15			RK73FB2A470J	CHIP R 47 J 1/10W	
L7			L34-4519-05	AIR-CORE COIL		R101			RK73GB1J470J	CHIP R 47 J 1/16W	
L8			L40-1585-48	SMALL FIXED INDUCTOR (150NH)		R102			RK73GB1J472J	CHIP R 4.7K J 1/16W	
L101			L40-8272-48	SMALL FIXED INDUCTOR		R103			RK73GB1J102J	CHIP R 1.0K J 1/16W	
L102			L40-3382-48	SMALL FIXED INDUCTOR		R104			RK73GB1J120J	CHIP R 12 J 1/16W	
L103			L40-3372-48	SMALL FIXED INDUCTOR		R105			RK73GB1J821J	CHIP R 820 J 1/16W	
L104			L40-3382-48	SMALL FIXED INDUCTOR		R106			RK73GB1J330J	CHIP R 33 J 1/16W	
L105			L40-8272-48	SMALL FIXED INDUCTOR		R107			RK73GB1J821J	CHIP R 820 J 1/16W	
L107			L40-2782-48	SMALL FIXED INDUCTOR		R108			RK73GB1J334J	CHIP R 330K J 1/16W	
L109			L40-6885-34	SMALL FIXED INDUCTOR (680NH)		R109			RK73GB1J332J	CHIP R 3.3K J 1/16W	
L110-112			L34-4080-05	COIL		R110,111			RK73GB1J104J	CHIP R 100K J 1/16W	
L114,115			L40-3375-34	SMALL FIXED INDUCTOR (33NH)		R112			RK73GB1J102J	CHIP R 1.0K J 1/16W	
L117			L34-4527-05	COIL		R113-115			RK73GB1J104J	CHIP R 100K J 1/16W	
L118,119			L34-4526-05	COIL		R116			R92-1252-05	CHIP R 0 OHM	
L120			L34-4527-05	COIL		R117			RK73GB1J101J	CHIP R 100 J 1/16W	
L121			L40-3975-34	SMALL FIXED INDUCTOR (39NH)	K	R118			RK73GB1J473J	CHIP R 47K J 1/16W	
L121			L40-4775-34	SMALL FIXED INDUCTOR (47NH)	K2	R119			RK73GB1J560J	CHIP R 56 J 1/16W	
L122			L34-4526-05	COIL		R120			RK73GB1J102J	CHIP R 1.0K J 1/16W	
L123			L34-4527-05	COIL		R121			RK73FB2A821J	CHIP R 820 J 1/10W	
L126			L40-1095-34	SMALL FIXED INDUCTOR (1UH)		R122			RK73FB2A5R6J	CHIP R 5.6 J 1/10W	
L127			L34-4530-05	COIL		R123			RK73GB1J270J	CHIP R 27 J 1/16W	
L128			L40-1885-34	SMALL FIXED INDUCTOR (180NH)		R124			RK73FB2A821J	CHIP R 820 J 1/10W	
L129			L40-1281-37	SMALL FIXED INDUCTOR (0.120UH)		R125-127			RK73GB1J222J	CHIP R 2.2K J 1/16W	
L130			L40-3381-37	SMALL FIXED INDUCTOR (0.330UH)		R128			RK73GB1J223J	CHIP R 22K J 1/16W	
L131			L40-3375-34	SMALL FIXED INDUCTOR (33NH)		R129			R92-1252-05	CHIP R 0 OHM	
L132,133			L40-2772-48	SMALL FIXED INDUCTOR	K	R132			RK73GB1J103J	CHIP R 10K J 1/16W	
L132,133			L40-3372-48	SMALL FIXED INDUCTOR	K2	R133			RK73GB1J472J	CHIP R 4.7K J 1/16W	
L134			L40-1095-34	SMALL FIXED INDUCTOR (1UH)		R134			RK73GB1J330J	CHIP R 33 J 1/16W	
L135,136			L40-1005-34	SMALL FIXED INDUCTOR (10UH)		R135			RK73GB1J220J	CHIP R 22 J 1/16W	
L201			L40-6875-34	SMALL FIXED INDUCTOR (68NH)		R136-138			RK73GB1J222J	CHIP R 2.2K J 1/16W	
L202			L40-8271-34	SMALL FIXED INDUCTOR (82NH)		R139			RK73GB1J473J	CHIP R 47K J 1/16W	
L301-304			L33-1268-15	SMALL FIXED INDUCTOR		R141			RK73GB1J102J	CHIP R 1.0K J 1/16W	
L305,306		*	L34-4592-05	AIR-CORE COIL		R142			RK73GB1J472J	CHIP R 4.7K J 1/16W	
L307-309			L33-1268-15	SMALL FIXED INDUCTOR		R143			RK73GB1J470J	CHIP R 47 J 1/16W	
L310			L40-8271-34	SMALL FIXED INDUCTOR (82NH)		R144			RK73GB1J153J	CHIP R 15K J 1/16W	
L311			L40-1085-34	SMALL FIXED INDUCTOR (100NH)		R145,146			RK73GB1J223J	CHIP R 22K J 1/16W	
L312			L92-0148-05	FERRITE CHIP		R148			RK73GB1J223J	CHIP R 22K J 1/16W	
L313,314			L40-3975-34	SMALL FIXED INDUCTOR (39NH)		R149			RK73GB1J274J	CHIP R 270K J 1/16W	
L501,502			L40-1005-34	SMALL FIXED INDUCTOR (10UH)		R150,151			RK73GB1J223J	CHIP R 22K J 1/16W	
X101			L77-1736-05	CRYSTAL RESONATOR (45.305MHZ)		R152			RK73GB1J472J	CHIP R 4.7K J 1/16W	
X301		*	L77-1798-05	VCXO (16.8MHZ)		R153			RK73GB1J182J	CHIP R 1.8K J 1/16W	
X501			L77-1708-05	CRYSTAL RESONATOR (3.579545MHZ)		R155			RK73GB1J472J	CHIP R 4.7K J 1/16W	
X502			L77-1863-05	CRYSTAL RESONATOR (12.0MHZ)		R156,157			RK73GB1J332J	CHIP R 3.3K J 1/16W	
XF101			L71-0512-05	MCF (44.85MHZ WIDE)		R158			RK73GB1J821J	CHIP R 820 J 1/16W	
XF102			L71-0513-05	MCF (44.85MHZ NARROW)		R159			RK73GB1J5R6J	CHIP R 5.6 J 1/16W	
R1			RK73FB2A821J	CHIP R 820 J 1/10W		R160			RK73GB1J821J	CHIP R 820 J 1/16W	
R2,3			RK73FB2A100J	CHIP R 10 J 1/10W		R161			R92-1252-05	CHIP R 0 OHM	
R4			RK73FB2A821J	CHIP R 820 J 1/10W		R162			RK73GB1J682J	CHIP R 6.8K J 1/16W	
R5			RK73GB1J104J	CHIP R 100K J 1/16W		R163			RK73GB1J182J	CHIP R 1.8K J 1/16W	
R6			R92-1214-05	CHIP R 120 J 1/2W		R164			RK73GB1J101J	CHIP R 100 J 1/16W	
R7			RK73GB1J392J	CHIP R 3.9K J 1/16W		R165			RK73GB1J393J	CHIP R 39K J 1/16W	
R8			RK73GB1J472J	CHIP R 4.7K J 1/16W		R166			RK73GB1J220J	CHIP R 22 J 1/16W	
R9			RK73GB1J103J	CHIP R 10K J 1/16W		R167			RK73GB1J102J	CHIP R 1.0K J 1/16W	
R10			RK73GB1J331J	CHIP R 330 J 1/16W	K2	R201			RK73GB1J271J	CHIP R 270 J 1/16W	
R10			RK73GB1J471J	CHIP R 470 J 1/16W	K	R202			RK73GB1J180J	CHIP R 18 J 1/16W	
R11			RK73GB1J102J	CHIP R 1.0K J 1/16W		R203			RK73GB1J102J	CHIP R 1.0K J 1/16W	
						R204			RK73GB1J271J	CHIP R 270 J 1/16W	

# TK-790/(B)/H(B)

## PARTS LIST

### TX-RX UNIT (X57-5610-XX) : TK-790/(B)

Ref. No.	Address	New parts	Parts No.	Description	Destination	Ref. No.	Address	New parts	Parts No.	Description	Destination
R205			RK73GB1J222J	CHIP R 2.2K J 1/16W		R358			RK73GB1J331J	CHIP R 330 J 1/16W	
R206			RK73GB1J103J	CHIP R 10K J 1/16W		R361			RK73GB1J102J	CHIP R 1.0K J 1/16W	
R207			RK73GB1J100J	CHIP R 10 J 1/16W		R366			R92-1252-05	CHIP R 0 OHM	
R208			RK73GB1J222J	CHIP R 2.2K J 1/16W		R501			RK73GB1J333J	CHIP R 33K J 1/16W	
R209			RK73GB1J560J	CHIP R 56 J 1/16W		R502			RK73GB1J471J	CHIP R 470 J 1/16W	
R210			RK73GB1J470J	CHIP R 47 J 1/16W		R504			R92-0670-05	CHIP R 0 OHM	
R211			RK73GB1J152J	CHIP R 1.5K J 1/16W		R505			RK73GB1J103J	CHIP R 10K J 1/16W	
R212			RK73GB1J472J	CHIP R 4.7K J 1/16W		R507			RK73GB1J223J	CHIP R 22K J 1/16W	
R213			RK73GB1J473J	CHIP R 47K J 1/16W		R508			RK73GB1J102J	CHIP R 1.0K J 1/16W	
R214			RK73GB1J100J	CHIP R 10 J 1/16W		R509-511			RK73GB1J473J	CHIP R 47K J 1/16W	
R215			RK73GB1J473J	CHIP R 47K J 1/16W		R512			RK73GB1J184J	CHIP R 180K J 1/16W	
R216			R92-0685-05	CHIP R 22 J 1/2W		R513			RK73GB1J223J	CHIP R 22K J 1/16W	
R217			RK73GB1J472J	CHIP R 4.7K J 1/16W		R514			RK73GB1J184J	CHIP R 180K J 1/16W	
R218			RK73FB2A821J	CHIP R 820 J 1/10W		R515			R92-0670-05	CHIP R 0 OHM	
R219,220			RK73FB2A100J	CHIP R 10 J 1/10W		R516			RK73GB1J104J	CHIP R 100K J 1/16W	
R221			RK73FB2A821J	CHIP R 820 J 1/10W		R517		*	RK73GH1J104D	CHIP R 100K D 1/16W	
R301-304			RK73GB1J103J	CHIP R 10K J 1/16W		R518			R92-1252-05	CHIP R 0 OHM	
R305			R92-1252-05	CHIP R 0 OHM		R519			RK73GB1J104J	CHIP R 100K J 1/16W	
R306			RK73GB1J560J	CHIP R 56 J 1/16W		R520		*	RK73GH1J334D	CHIP R 330K D 1/16W	
R307,308			RK73GB1J100J	CHIP R 10 J 1/16W		R521			RK73GB1J102J	CHIP R 1.0K J 1/16W	
R309			R92-1252-05	CHIP R 0 OHM		R522			RK73GH1J913D	CHIP R 91K D 1/16W	
R310,311			RK73GB1J152J	CHIP R 1.5K J 1/16W		R523			RK73GB1J474J	CHIP R 470K J 1/16W	
R312			RK73GB1J682J	CHIP R 6.8K J 1/16W		R524			RK73GH1J224D	CHIP R 220K D 1/16W	
R313			RK73GB1J223J	CHIP R 22K J 1/16W		R525			RK73GB1J472J	CHIP R 4.7K J 1/16W	
R314,315			RK73GB1J221J	CHIP R 220 J 1/16W		R526			RK73GB1J104J	CHIP R 100K J 1/16W	
R316			RK73GB1J222J	CHIP R 2.2K J 1/16W		R527			RK73GB1J223J	CHIP R 22K J 1/16W	
R317			RK73GB1J474J	CHIP R 470K J 1/16W		R528			RK73GB1J104J	CHIP R 100K J 1/16W	
R318			RK73FB2A152J	CHIP R 1.5K J 1/10W		R529,530			RK73GB1J334J	CHIP R 330K J 1/16W	
R319			RK73GB1J102J	CHIP R 1.0K J 1/16W		R531			RK73GB1J154J	CHIP R 150K J 1/16W	
R320-323			R92-1252-05	CHIP R 0 OHM		R532			RK73GB1J474J	CHIP R 470K J 1/16W	
R324			RK73GB1J223J	CHIP R 22K J 1/16W		R533			RN73GH1J473D	CHIP R 47K D 1/16W	
R325			RK73GB1J103J	CHIP R 10K J 1/16W		R534			RN73GH1J563D	CHIP R 56K D 1/16W	
R326			RK73GB1J330J	CHIP R 33 J 1/16W		R535			RK73GB1J103J	CHIP R 10K J 1/16W	
R327			RK73GB1J104J	CHIP R 100K J 1/16W		R536			RK73GB1J681J	CHIP R 680 J 1/16W	
R328			RK73GB1J330J	CHIP R 33 J 1/16W		R537			RK73GB1J472J	CHIP R 4.7K J 1/16W	
R329			RK73GB1J471J	CHIP R 470 J 1/16W	K	R539			RK73GB1J561J	CHIP R 560 J 1/16W	
R329			RK73GB1J561J	CHIP R 560 J 1/16W	K2	R541			R92-0670-05	CHIP R 0 OHM	
R330			RK73GB1J271J	CHIP R 270 J 1/16W	K2	R542			RK73GB1J470J	CHIP R 47 J 1/16W	
R330			RK73GB1J331J	CHIP R 330 J 1/16W	K	R543			RK73GB1J220J	CHIP R 22 J 1/16W	
R331,332			RK73GB1J472J	CHIP R 4.7K J 1/16W		R545			RK73GB1J564J	CHIP R 560K J 1/16W	
R333			RK73GB1J470J	CHIP R 47 J 1/16W		R546			R92-0670-05	CHIP R 0 OHM	
R334			RK73GB1J472J	CHIP R 4.7K J 1/16W		R547			R92-1252-05	CHIP R 0 OHM	
R335			RK73GB1J470J	CHIP R 47 J 1/16W		R549			RK73GB1J153J	CHIP R 15K J 1/16W	
R336,337			RK73GB1J472J	CHIP R 4.7K J 1/16W		R550			RK73GB1J683J	CHIP R 68K J 1/16W	
R338			RK73GB1J473J	CHIP R 47K J 1/16W		R552			RK73GB1J101J	CHIP R 100 J 1/16W	
R339			RK73GB1J103J	CHIP R 10K J 1/16W		R553			RK73GB1J822J	CHIP R 8.2K J 1/16W	
R340			RK73GB1J330J	CHIP R 33 J 1/16W		R557,558			RK73GB1J104J	CHIP R 100K J 1/16W	
R341			RK73GB1J331J	CHIP R 330 J 1/16W		R559			RK73GB1J473J	CHIP R 47K J 1/16W	
R342			RK73GB1J223J	CHIP R 22K J 1/16W		R561			RK73GB1J102J	CHIP R 1.0K J 1/16W	
R343			RK73GB1J103J	CHIP R 10K J 1/16W		R562			RK73GB1J274J	CHIP R 270K J 1/16W	
R344			RK73GB1J223J	CHIP R 22K J 1/16W		R563			RK73GB1J104J	CHIP R 100K J 1/16W	
R345			RK73GB1J103J	CHIP R 10K J 1/16W		R564			RK73GB1J474J	CHIP R 470K J 1/16W	
R346			RK73GB1J330J	CHIP R 33 J 1/16W		R565			RK73GB1J123J	CHIP R 12K J 1/16W	
R347			RK73GB1J471J	CHIP R 470 J 1/16W		R566			RK73GB1J153J	CHIP R 15K J 1/16W	
R348			RK73GB1J331J	CHIP R 330 J 1/16W		R567			RK73GB1J224J	CHIP R 220K J 1/16W	
R349			RK73GB1J330J	CHIP R 33 J 1/16W		R568			R92-1252-05	CHIP R 0 OHM	
R350			RK73GB1J101J	CHIP R 100 J 1/16W		R570			RK73GB1J223J	CHIP R 22K J 1/16W	
R351,352			RK73GB1J102J	CHIP R 1.0K J 1/16W		R572			RK73GB1J104J	CHIP R 100K J 1/16W	
R354,355			RK73GB1J220J	CHIP R 22 J 1/16W		R573			RK73GB1J274J	CHIP R 270K J 1/16W	
R357			R92-1252-05	CHIP R 0 OHM		R574			RK73GB1J102J	CHIP R 1.0K J 1/16W	

## PARTS LIST

TX-RX UNIT (X57-5610-XX) : TK-790/(B)

Ref. No.	Address	New parts	Parts No.	Description	Destination	Ref. No.	Address	New parts	Parts No.	Description	Destination
R575,576			RK73GB1J104J	CHIP R 100K J 1/16W		R665			RK73GB1J104J	CHIP R 100K J 1/16W	
R577			RK73GB1J122J	CHIP R 1.2K J 1/16W		R666,667			R92-0670-05	CHIP R 0 OHM	
R578			RK73GB1J102J	CHIP R 1.0K J 1/16W		R668			R92-1252-05	CHIP R 0 OHM	
R579,580			RK73GB1J823J	CHIP R 82K J 1/16W		R670			R92-0670-05	CHIP R 0 OHM	
R581,582			RK73GB1J683J	CHIP R 68K J 1/16W		R671			RK73GB1J683J	CHIP R 68K J 1/16W	
R583			R92-0670-05	CHIP R 0 OHM		R672			RK73GB1J473J	CHIP R 47K J 1/16W	
R584			RK73GB1J333J	CHIP R 33K J 1/16W		R674,675			RK73GB1J472J	CHIP R 4.7K J 1/16W	
R586			RK73GB1J104J	CHIP R 100K J 1/16W		R676			RK73GB1J473J	CHIP R 47K J 1/16W	
R587			R92-0670-05	CHIP R 0 OHM		R677			RK73GB1J472J	CHIP R 4.7K J 1/16W	
R588			RK73GB1J473J	CHIP R 47K J 1/16W		R678,679			RK73GB1J332J	CHIP R 3.3K J 1/16W	
R589			RK73GB1J223J	CHIP R 22K J 1/16W		R680			RK73GB1J104J	CHIP R 100K J 1/16W	
R591,592			RK73GB1J124J	CHIP R 120K J 1/16W		R690,691			R92-0670-05	CHIP R 0 OHM	
R594-597			RK73GB1J473J	CHIP R 47K J 1/16W		R693			RK73GB1J103J	CHIP R 10K J 1/16W	
R598			RK73GB1J332J	CHIP R 3.3K J 1/16W		R695			R92-1252-05	CHIP R 0 OHM	
R599,600			RK73GB1J473J	CHIP R 47K J 1/16W		R697			R92-1252-05	CHIP R 0 OHM	
R601			RK73GB1J472J	CHIP R 4.7K J 1/16W		R698			RK73GB1J472J	CHIP R 4.7K J 1/16W	
R602			RK73FB2A473J	CHIP R 47K J 1/10W		R699			R92-1252-05	CHIP R 0 OHM	
R603			RK73GB1J103J	CHIP R 10K J 1/16W		R700			RK73GB1J220J	CHIP R 22 J 1/16W	
R604			R92-0670-05	CHIP R 0 OHM		R701			RK73GB1J103J	CHIP R 10K J 1/16W	
R605			RK73GB1J333J	CHIP R 33K J 1/16W		R702			RK73GB1J472J	CHIP R 4.7K J 1/16W	
R606			RK73GB1J154J	CHIP R 150K J 1/16W		R703			RK73GB1J473J	CHIP R 47K J 1/16W	
R607			R92-1252-05	CHIP R 0 OHM		R706			R92-0670-05	CHIP R 0 OHM	
R608			RK73GB1J123J	CHIP R 12K J 1/16W		R707-713			RK73GB1J474J	CHIP R 470K J 1/16W	
R609			RK73GB1J153J	CHIP R 15K J 1/16W		R714			RK73GB1J104J	CHIP R 100K J 1/16W	
R611			RK73GB1J474J	CHIP R 470K J 1/16W		R715			RK73GB1J474J	CHIP R 470K J 1/16W	
R612			RK73GB1J823J	CHIP R 82K J 1/16W		R716			RK73GB1J104J	CHIP R 100K J 1/16W	
R613			RK73GB1J393J	CHIP R 39K J 1/16W		R717			RK73GB1J102J	CHIP R 1.0K J 1/16W	
R615			RK73GB1J122J	CHIP R 1.2K J 1/16W		R718			RK73GB1J333J	CHIP R 33K J 1/16W	
R616			RK73GB1J152J	CHIP R 1.5K J 1/16W		R719			RS14DB3D2R2J	FL-PROOF RS 2.2 J 2W	
R617			RN73GH1J274D	CHIP R 270K D 1/16W		R720			R92-0670-05	CHIP R 0 OHM	
R618			RN73GH1J334D	CHIP R 330K D 1/16W		R721			RK73GB1J393J	CHIP R 39K J 1/16W	
R619,620			RN73GH1J274D	CHIP R 270K D 1/16W		R722			RK73GB1J184J	CHIP R 180K J 1/16W	
R621			RK73GB1J472J	CHIP R 4.7K J 1/16W		R723			R92-0670-05	CHIP R 0 OHM	
R622			RK73GB1J473J	CHIP R 47K J 1/16W		R724			RK73GB1J683J	CHIP R 68K J 1/16W	
R623			RN73GH1J274D	CHIP R 270K D 1/16W		R725			RK73GB1J333J	CHIP R 33K J 1/16W	
R624			RK73GB1J103J	CHIP R 10K J 1/16W		R726			RK73GB1J122J	CHIP R 1.2K J 1/16W	
R625			RK73GB1J684J	CHIP R 680K J 1/16W		R727			RK73GB1J473J	CHIP R 47K J 1/16W	
R626			RK73GB1J822J	CHIP R 8.2K J 1/16W		R728			R92-0670-05	CHIP R 0 OHM	
R627			RN73GH1J274D	CHIP R 270K D 1/16W		R729-736			RK73GB1J472J	CHIP R 4.7K J 1/16W	
R628			R92-0670-05	CHIP R 0 OHM		R740,741			RK73GB1J103J	CHIP R 10K J 1/16W	
R629			RN73GH1J563D	CHIP R 56K D 1/16W		R742			R92-0670-05	CHIP R 0 OHM	
R630			RN73GH1J473D	CHIP R 47K D 1/16W		R744			RK73GB1J104J	CHIP R 100K J 1/16W	
R631			RK73GB1J104J	CHIP R 100K J 1/16W		R746			R92-1252-05	CHIP R 0 OHM	
R632			RK73GB1J102J	CHIP R 1.0K J 1/16W		R747			R92-0670-05	CHIP R 0 OHM	
R633,634			RK73GB1J103J	CHIP R 10K J 1/16W		R748			R92-1252-05	CHIP R 0 OHM	
R635			R92-0670-05	CHIP R 0 OHM		VR1			R12-6427-05	TRIMMING POT. (47K)	
R636		*	RK73GH1J104D	CHIP R 100K D 1/16W		VR501			R12-6417-05	TRIMMING POT. (1K)	
R638			RK73GH1J223D	CHIP R 22K D 1/16W		D1			DSA3A1-FK	DIODE	
R639			RK73GB1J473J	CHIP R 47K J 1/16W		D2			22ZR-10D	SURGE ABSORBER	
R641			R92-0670-05	CHIP R 0 OHM		D3			MA4PH633	DIODE	
R642-648			RK73FB2A102J	CHIP R 1.0K J 1/10W		D4			MI809	DIODE	
R652			RK73FB2A102J	CHIP R 1.0K J 1/10W		D4			XB15A709	DIODE	
R654-656			RK73FB2A102J	CHIP R 1.0K J 1/10W		D5,6			HSM88AS	DIODE	
R657			R92-0670-05	CHIP R 0 OHM		D101			1SS355	DIODE	
R658			RK73GB1J473J	CHIP R 47K J 1/16W		D102			1SV269	VARIABLE CAPACITANCE DIODE	
R659			RK73GB1J563J	CHIP R 56K J 1/16W		D103			MA742	DIODE	
R661			R92-0670-05	CHIP R 0 OHM		D104,105			1SV269	VARIABLE CAPACITANCE DIODE	
R662			RK73GB1J472J	CHIP R 4.7K J 1/16W		D106-109			DAN235K	DIODE	
R663			RK73GB1J473J	CHIP R 47K J 1/16W		D201,202			DA204K	DIODE	
R664			RK73GB1J333J	CHIP R 33K J 1/16W							

# TK-790/(B)/H(B)

## PARTS LIST

TX-RX UNIT (X57-5610-XX) : TK-790/(B)  
TK-790H(B)

Ref. No.	Address	New parts	Parts No.	Description	Destination	Ref. No.	Address	New parts	Parts No.	Description	Destination
D301-304			1SV282	VARIABLE CAPACITANCE DIODE		Q107			2SC4215(Y)	TRANSISTOR	
D305			1SV214	VARIABLE CAPACITANCE DIODE		Q108			DTC144EUA	DIGITAL TRANSISTOR	
D306			DAN235K	DIODE		Q109			2SC4617(S)	TRANSISTOR	
D501			02CZ18(X,Y)	ZENER DIODE		Q201			2SC3357	TRANSISTOR	
D502,503			1SS355	DIODE		Q202			2SB1132(Q,R)	TRANSISTOR	
D504			02CZ5.6(X,Y)	ZENER DIODE		Q203			DTC114EUA	DIGITAL TRANSISTOR	
D505			1SS355	DIODE		Q204			2SC2954	TRANSISTOR	
D506			1SS301	DIODE		Q205			DTC114EUA	DIGITAL TRANSISTOR	
D507			02CZ15(X,Y)	ZENER DIODE		Q206			2SB1132(Q,R)	TRANSISTOR	
D508			1SS355	DIODE		Q301,302			2SC4116(GR)	TRANSISTOR	
D511			1SS301	DIODE		Q303,304			2SC3722K(S)	TRANSISTOR	
D512			1SS355	DIODE		Q305,306			2SK508NV(K52)	FET	
D513-517			DA204U	DIODE		Q307,308			2SC4116(Y)	TRANSISTOR	
D519			DA204U	DIODE		Q309			DTC114EUA	DIGITAL TRANSISTOR	
D521			DA204U	DIODE		Q310,311			2SC4215(Y)	TRANSISTOR	
D523,524			DA204U	DIODE		Q312			2SC3120	TRANSISTOR	
D526,527			DA204U	DIODE		Q501			DTA114EUA	DIGITAL TRANSISTOR	
D528,529			1SS355	DIODE		Q502,503			DTC114EUA	DIGITAL TRANSISTOR	
IC1			M68702H	IC (RF POWER MODULE)	K	Q504			DTC363EK	DIGITAL TRANSISTOR	
IC1			M68702L	IC (RF POWER MODULE)	K2	Q505			DTC144EUA	DIGITAL TRANSISTOR	
IC101			TA31136FN	IC (FM IC)		Q506			DTA114YUA	DIGITAL TRANSISTOR	
IC201			BU4094BCF	IC (SHIFT REGISTER)		Q507			DTC114YUA	DIGITAL TRANSISTOR	
IC202			NJM78L05UA	IC (AVR)		Q509-513			DTC144EUA	DIGITAL TRANSISTOR	
IC203			AN8009M	IC (AVR)		Q514			DTA144TKA	DIGITAL TRANSISTOR	
IC301			SA7025DK	IC (PLL IC)		Q516			DTA114TUA	DIGITAL TRANSISTOR	
IC501			TC4013BF(N)	IC (D FF)		Q517			DTC144EUA	DIGITAL TRANSISTOR	
IC502			NJM4558M	IC (LPF)		Q518			DTA114EUA	DIGITAL TRANSISTOR	
IC503			TA7808S	IC (AVR)		Q519			2SJ506(S)	FET	
IC504			TC35453F	IC (AUDIO PROCESSOR)		Q520			DTD114EK	DIGITAL TRANSISTOR	
IC505			NJM4558M	IC (HPF/IDC)		Q522			2SC4215(Y)	TRANSISTOR	
IC506			L78LR05B-FA	IC (AVR)		Q523,524			DTC114TU	DIGITAL TRANSISTOR	
IC508			NJM4558M	IC (LIMITER/BUFFER AMP)		Q525			DTC144EUA	DIGITAL TRANSISTOR	
IC509			MC33172D	IC (BUFFER AMP)		Q526			DTA114TUA	DIGITAL TRANSISTOR	
IC510			NJM4558M	IC (SUMMING AMP/LPF)		Q527			DTC144EUA	DIGITAL TRANSISTOR	
IC511			PCD3312CT	IC (DTMF ENCODER)		Q528			DTA114TUA	DIGITAL TRANSISTOR	
IC512			M62364FP	IC (D/A CONVERTER)		Q529,530			DTC144EUA	DIGITAL TRANSISTOR	
IC513			NJM4558M	IC (LPF/SUMMING AMP)		Q531			DTA114TUA	DIGITAL TRANSISTOR	
IC514			AT24C64N10SI27	IC (EEPROM)		Q532-536			DTC144EUA	DIGITAL TRANSISTOR	
IC515			BU4066BCF	IC (ANALOG SWITCH)		Q537-540			DTD114EK	DIGITAL TRANSISTOR	
IC516		*	784214GC0518EU	IC (CPU)		Q541			DTC114EUA	DIGITAL TRANSISTOR	
IC517			BU4094BCF	IC (SHIFT REGISTER)		Q542			DTA114EUA	DIGITAL TRANSISTOR	
IC518			NJM4558M	IC (BUFFER AMP)		Q543,544			DTC114EUA	DIGITAL TRANSISTOR	
IC519			AT29C020-90TI	IC (FLASH ROM)		TH101			157-503-53006	THERMISTOR	
IC520			TC7S02F	IC (NOR GATE)		TH501			157-302-53008	THERMISTOR	
IC521			NJM4558M	IC (BUFFER AMP)		A101			W02-1939-05	DBM	
IC522			TDA8561Q	IC (AUDIO POWER AMP)		<b>TK-790H(B)</b>					
IC523			BU4094BCF	IC (SHIFT REGISTER)		101	3D		A01-2163-01	CABINET (UPPER)	
IC524			NJM4558M	IC (BUFFER AMP/DE-EMPHASIS)		102	1C		A01-2164-01	CABINET (LOWER)	
IC525			LC73872M	IC (DTMF DECODER)		103	2D		A10-1389-01	CHASSIS	
IC526			TA75S01F	IC (COMPANDER AMP)		106	3C,3D		B42-2455-04	STICKER (M4X8 MAX)	
Q1			2SA1162(Y)	TRANSISTOR		107	1K		B46-0470-00	WARRANTY CARD	ACSY
Q2			2SD2399	TRANSISTOR		108	1K	*	B62-0970-10	INSTRUCTION MANUAL	
Q3			2SC2712(Y)	TRANSISTOR		-		*	B72-1453-34	MODEL NAME PLATE	
Q4			DTC144EUA	DIGITAL TRANSISTOR		111	2D		E04-0167-05	RF COAXIAL PECEPTACLE (M)	
Q5			FMW1	TRANSISTOR							
Q6			2SC2712(Y)	TRANSISTOR							
Q101,102			2SC3357	TRANSISTOR							
Q104			2SC3357	TRANSISTOR							
Q105			DTA144EUA	DIGITAL TRANSISTOR							
Q106			DTC144EUA	DIGITAL TRANSISTOR							

## PARTS LIST

TK-790H(B)  
FINAL UNIT (X45-3560-10) : TK-790H(B)

Ref. No.	Address	New parts	Parts No.	Description	Destination	Ref. No.	Address	New parts	Parts No.	Description	Destination
113	2C		E31-3301-05	LEAD WIRE WITH MINIPIN PLUG (RA/DO)		C22,23			CM73F2H681J	CHIP C 680PF J	
114	2D		E37-0709-05	LEAD WIRE WITH CONNECTOR (ACC:9P)		C24,25			CM73F2H201J	CHIP C 200PF J	
115	2D		E37-0731-05	LEAD WIRE WITH CONNECTOR (DC:2P)		C26,27			CK73FB1H102K	CHIP C 1000PF K	
116	2D,1L		E37-0733-05	SHORT PLUG (SP) ACSY		C28-31			CM73F2H271J	CHIP C 270PF J	
117	2D	*	E37-0773-25	LEAD WIRE WITH CONNECTOR (D-SUB:25P)		C32-35			CM73F2H221J	CHIP C 220PF J	
118	3C		E37-0776-05	FLAT CABLE (CONT-TX:18P)		C36,37			CK73FB1H102K	CHIP C 1000PF K	
123	2D		F09-0445-05	CAP (D-SUB)		C38			CK73FB1H103K	CHIP C 0.010UF K	
124	1D		F10-1488-02	SHIELDING PLATE (FINAL)		C39			CK73FB1E104K	CHIP C 0.10UF K	
122	1L		F29-0472-04	INSULATING COVER ACSY		C40,41			CM73F2H681J	CHIP C 680PF J	
127	3C		G02-0709-04	FLAT SPRING (AUDIO AMP)		C42			CK73FB1H102K	CHIP C 1000PF K	
128	3C		G02-0715-04	FLAT SPRING (AVR)		C43			CM73F2H620J	CHIP C 62PF J	
129	2D		G53-0715-03	PACKING (DC,ACC)		C44			C92-0736-05	ELECTRO 10UF 50WV	
132	3D		G53-0871-03	PACKING (CABINET UPPER)		C45			CK73FB1H103K	CHIP C 0.010UF K	
133	1C		G53-0872-03	PACKING (CABINET LOWER)		C46			CM73F2H620J	CHIP C 62PF J	
135	1K		H02-0604-03	INNER PACKING CASE		C47			CK73FB1H102K	CHIP C 1000PF K	
136	2L		H10-6617-11	POLYSTYRENE FOAMED FIXTURE		C48			CK73FB1E104K	CHIP C 0.10UF K	
137	1L		H11-0815-04	POLYSTYRENE FOAMED BOARD		C49			CM73F2H470J	CHIP C 47PF J	
138	2L		H11-0853-04	POLYSTYRENE FOAMED BOARD		C50			C92-0736-05	ELECTRO 10UF 50WV	
139	2K		H11-0892-04	POLYSTYRENE FOAMED BOARD		C51			CM73F2H180J	CHIP C 18PF J	
140	2K		H12-1410-04	PACKING FIXTURE		C52			CK73FB1H102K	CHIP C 1000PF K	
141	2L		H12-1442-04	PACKING FIXTURE		C53			CC73FCH1H220J	CHIP C 22PF J	
142	2K		H13-1066-04	CARTON BOARD		C55			CK73FB1H102K	CHIP C 1000PF K	
144	1L		H25-0103-04	PROTECTION BAG (125/250/0.07)		C57-59			CK73FB1H102K	CHIP C 1000PF K	
145	1K		H25-0724-04	PROTECTION BAG (300/500/0.07)		C60			CC73FCH1H020C	CHIP C 2.0PF C	
143	1L	*	H25-2063-04	PROTECTION BAG (80/120/0.03)		C61-63			CK73FB1H102K	CHIP C 1000PF K	
146	3L		H52-1229-12	ITEM CARTON CASE		C64			CM73F2H100D	CHIP C 10PF D	
147	2D		J21-8347-04	HARDWARE FIXTURE (DC,ACC)		C65			C92-0729-05	ELECTRO 330UF 25WV	
148	1D		J32-0919-04	HEXAGON BOSS (FINAL)		C66		*	CM73F2H360F	CHIP C 36PF F	
150	1L		J61-0307-05	BAND ACSY		C67			C92-0729-05	ELECTRO 330UF 25WV	
M	2D		N09-2292-05	HEXAGON HEAD SCREW		C68,69			CK73FB1H102K	CHIP C 1000PF K	
N	1C,3D		N33-3006-45	OVAL HEAD MACHINE SCREW		C70		*	CM73F2H360F	CHIP C 36PF F	
O	1D		N35-3006-46	BINDING HEAD MACHINE SCREW		C71			CM73F2H080D	CHIP C 8.0PF D	
P	2C,2D		N67-3008-46	PAN HEAD SEMS SCREW W		C72			CM73F2H180J	CHIP C 18PF J	
Q	1C,1D		N68-4006-46	PAN HEAD SEMS SCREW A		C73,74			CK73FB1H102K	CHIP C 1000PF K	
R	2C,3D		N87-2606-46	BRAZIER HEAD TAPTITE SCREW		C75,76			CK73FB1H103K	CHIP C 0.010UF K	
S	2C		N87-2612-46	BRAZIER HEAD TAPTITE SCREW		C77,78			CK73FB1E104K	CHIP C 0.10UF K	
T	2D		N87-3008-46	BRAZIER HEAD TAPTITE SCREW		C79			CK73FB1H103K	CHIP C 0.010UF K	
159	2L		N99-0365-05	SCREW SET ACSY		C80			CK73FB1E104K	CHIP C 0.10UF K	
						C81			CK73FB1H103K	CHIP C 0.010UF K	
						C82			CK73FB1E104K	CHIP C 0.10UF K	
<b>FINAL UNIT (X45-3560-10) : TK-790H(B)</b>						CN1,2			E04-0154-05	PIN SOCKET	
						CN3,4			E23-1116-05	RELAY TERMINAL	
						W1,2			E37-0783-05	PROCESSED LEAD WIRE	
						W4			E37-0706-05	LEAD WIRE WITH CONNECTOR	
						W5			E37-0701-05	LEAD WIRE WITH CONNECTOR	
C1-6			CK73FB1H102K	CHIP C 1000PF K		L1			L34-1039-05	AIR-CORE COIL	
C7			C92-0736-05	ELECTRO 10UF 50WV		L2			L39-0421-04	COIL	
C8			CK73FB1E104K	CHIP C 0.10UF K		L3,4			L34-1231-15	AIR-CORE COIL	
C9			C90-2020-05	ELECTRO 15UF 25WV		L5			L34-1246-15	AIR-CORE COIL	
C10			C92-0727-05	ELECTRO 220UF 35WV		L6			L34-1247-05	AIR-CORE COIL	
C11,12			CK73FB1H102K	CHIP C 1000PF K		L7,8			L34-1232-15	AIR-CORE COIL	
C13			CM73F2H160J	CHIP C 16PF J		L9			L34-1231-15	AIR-CORE COIL	
C14			C92-0736-05	ELECTRO 10UF 50WV		L10			L34-1088-05	AIR-CORE COIL	
C15			CK73FB1H102K	CHIP C 1000PF K		L11			L40-1885-34	SMALL FIXED INDUCTOR (180NH)	
C16			CM73F2H430J	CHIP C 43PF J		R1			RK73FB2A100J	CHIP R 10 J 1/10W	
C17			CK73FB1H102K	CHIP C 1000PF K		R2			RK73FB2A473J	CHIP R 47K J 1/10W	
C18			C92-0726-05	ELECTRO 47UF 25WV		R4			RK73FB2A103J	CHIP R 10K J 1/10W	
C19			CM73F2H161J	CHIP C 160PF J		R5			RK73FB2A471J	CHIP R 470 J 1/10W	
C20			CK73FB1H102K	CHIP C 1000PF K		R6			RK73FB2A472J	CHIP R 4.7K J 1/10W	
C21			CM73F2H201J	CHIP C 200PF J							

# TK-790/(B)/H(B)

## PARTS LIST

FINAL UNIT (X45-3560-10) : TK-790H(B)

TX-RX UNIT (X57-5610-12) : TK-790H(B)

Ref. No.	Address	New parts	Parts No.	Description	Destination	Ref. No.	Address	New parts	Parts No.	Description	Destination
R7			RK73FB2A392J	CHIP R 3.9K J 1/10W		C125			CK73GB1H103K	CHIP C 0.010UF K	
R8			RD14DB3A3R3J	SMALL-RD 3.3 J 1W		C126			CC73GCH1H150J	CHIP C 15PF J	
R9,10			RS14DB3D2R2J	FL-PROOF RS 2.2 J 2W		C127			CC73GCH1H151J	CHIP C 150PF J	
R11			RK73FB2A182J	CHIP R 1.8K J 1/10W		C128			CC73GCH1H030C	CHIP C 3.0PF C	
R12			RK73FB2A102J	CHIP R 1.0K J 1/10W		C129			CC73GCH1H101J	CHIP C 100PF J	
R13			RD14DB3A3R3J	SMALL-RD 3.3 J 1W		C130			CC73GCH1H270J	CHIP C 27PF J	
R16,17			R92-1221-05	CHIP R 82 J 1/4W		C131			CK73GB1H102K	CHIP C 1000PF K	
R18			RK73FB2A122J	CHIP R 1.2K J 1/10W		C132			CC73GCH1H030C	CHIP C 3.0PF C	
R19			RK73FB2A103J	CHIP R 10K J 1/10W		C133			CC73GCH1H270J	CHIP C 27PF J	
R20			RK73FB2A821J	CHIP R 820 J 1/10W		C134,135			CK73GB1H103K	CHIP C 0.010UF K	
R21			RK73FB2A100J	CHIP R 10 J 1/10W		C138-140			CC73GCH1H030C	CHIP C 3.0PF C	
R22			RK73FB2A821J	CHIP R 820 J 1/10W		C141			CC73GCH1H040C	CHIP C 4.0PF C	
R23			RK73FB2A104J	CHIP R 100K J 1/10W		C143			CK73GB1H102K	CHIP C 1000PF K	
R24			RK73FB2A561J	CHIP R 560 J 1/10W		C144			CC73GCH1H101J	CHIP C 100PF J	
R25			R92-1061-05	JUMPER REST 0 OHM		C145,146			CC73GCH1H030C	CHIP C 3.0PF C	
VR1			R12-6421-05	TRIMMING POT. (4.7K)		C147			CC73FCH1H090D	CHIP C 9.0PF D	
K1			S51-1437-05	RELAY		C148			CK73GB1H102K	CHIP C 1000PF K	
D1,2			HSM88AS	DIODE		C151,152			CK73GB1H103K	CHIP C 0.010UF K	
D3			1SS184	DIODE		C153,154			CK73GB1H102K	CHIP C 1000PF K	
D4			22ZR-10D	SURGE ABSORBER		C155			CC73GCH1H100D	CHIP C 10PF D	
D5			1SS193	DIODE		C156			CK73FB1E104K	CHIP C 0.10UF K	
D6			02CZ10(X,Y)	ZENER DIODE		C157			CC73GCH1H090D	CHIP C 9.0PF D	
D7			SG-5L(R)	DIODE		C158			CC73GCH1H101J	CHIP C 100PF J	
IC1			M67741H-32	IC (RF POWER MODULE)		C159			CC73GCH1H220J	CHIP C 22PF J	
Q1,2			2SC2712(Y)	TRANSISTOR		C160			CK73GB1H102K	CHIP C 1000PF K	
Q3			2SD2531	TRANSISTOR		C161-163			CK73GB1H103K	CHIP C 0.010UF K	
Q4			2SA1162(Y)	TRANSISTOR		C165			C92-0560-05	CHIP-TAN 10UF 6.3WV	
Q5			FMW1	TRANSISTOR		C166			CC73GCH1H080D	CHIP C 8.0PF D	
Q6,7			2SC2782	TRANSISTOR		C167			CC73GCH1H270J	CHIP C 27PF J	
Q8			FMC2	DIGITAL TRANSISTOR		C168			CK73FB1E104K	CHIP C 0.10UF K	
Q9			2SD1624(S)	TRANSISTOR		C169			CK73GB1H103K	CHIP C 0.010UF K	
Q10			2SC2712(Y)	TRANSISTOR		C170,171			CC73GCH1H221J	CHIP C 220PF J	
Q11			DTC144EUA	DIGITAL TRANSISTOR		C172			CK73GB1H472K	CHIP C 4700PF K	
TH1			PTH9M04BC471TS	THERMISTOR		C173			CK73GB1H103K	CHIP C 0.010UF K	
						C174			CK73FB1E104K	CHIP C 0.10UF K	
						C175			CK73GB1C333K	CHIP C 0.033UF K	
						C176			C92-0003-05	CHIP-TAN 0.47UF 25WV	
						C177			CK73GB1H102K	CHIP C 1000PF K	
						C178			CK73GB1H103K	CHIP C 0.010UF K	
						C179-182			CC73GCH1H470J	CHIP C 47PF J	
<b>TX-RX UNIT (X57-5610-12) : TK-790H(B) K</b>											
C101			CK73GB1H103K	CHIP C 0.010UF K		C183-185			CC73GCH1H150J	CHIP C 15PF J	
C102,103			CC73GCH1H220J	CHIP C 22PF J		C186			CC73GCH1H330J	CHIP C 33PF J	
C104			CC73GCH1H180J	CHIP C 18PF J		C187,188			CC73GCH1H120J	CHIP C 12PF J	
C105			CC73GCH1H101J	CHIP C 100PF J		C189			CK73GB1E223K	CHIP C 0.022UF K	
C106			CK73GB1H103K	CHIP C 0.010UF K		C190			CK73GB1H102K	CHIP C 1000PF K	
C107			CC73GCH1H101J	CHIP C 100PF J		C191			CK73GB1E223K	CHIP C 0.022UF K	
C108			CC73GCH1H100D	CHIP C 10PF D		C192			CK73FB1C334K	CHIP C 0.33UF K	
C110			CC73GCH1H100D	CHIP C 10PF D		C193			CK73GB1H102K	CHIP C 1000PF K	
C111			CC73GCH1H020C	CHIP C 2.0PF C		C194			C92-0560-05	CHIP-TAN 10UF 6.3WV	
C112			CK73GB1H103K	CHIP C 0.010UF K		C195			CK73GB1H102K	CHIP C 1000PF K	
C113			CK73GB1H102K	CHIP C 1000PF K		C201			CK73GB1H471K	CHIP C 470PF K	
C114			CC73GCH1H100D	CHIP C 10PF D		C202			CC73GCH1H101J	CHIP C 100PF J	
C116			CC73GCH1H020C	CHIP C 2.0PF C		C203-205			CK73GB1H102K	CHIP C 1000PF K	
C117			CC73GCH1H680J	CHIP C 68PF J		C206			CK73GB1H103K	CHIP C 0.010UF K	
C118			CC73GCH1H080D	CHIP C 8.0PF D		C207			C92-0044-05	CHIP-ELE 47UF 10WV	
C119			CC73GCH1H180J	CHIP C 18PF J		C208			CK73GB1H102K	CHIP C 1000PF K	
C120			CC73GCH1H120J	CHIP C 12PF J		C209			C92-0023-05	CHIP-ELE 1.0UF 50WV	
C121			CC73GCH1H101J	CHIP C 100PF J		C210			CK73GB1H102K	CHIP C 1000PF K	
C123			CC73GCH1H221J	CHIP C 220PF J		C211			CC73GCH1H270J	CHIP C 27PF J	
C124			CC73GCH1H330J	CHIP C 33PF J		C213,214			CK73GB1H102K	CHIP C 1000PF K	

## PARTS LIST

TX-RX UNIT (X57-5610-12) : TK-790H(B)

Ref. No.	Address	New parts	Parts No.	Description	Desti-nation	Ref. No.	Address	New parts	Parts No.	Description	Desti-nation
C215			CK73FB1E104K	CHIP C 0.10UF K		C525			CK73FB1E683K	CHIP C 0.068UF K	
C216			CK73GB1C473K	CHIP C 0.047UF K		C526,527			CK73GB1H471K	CHIP C 470PF K	
C217			C92-0008-05	CHIP-TAN 3.3UF 16WV		C528			CC73GCH1H101J	CHIP C 100PF J	
C218,219			CK73GB1H102K	CHIP C 1000PF K		C529			C92-0585-05	CHIP-TAN 4.7UF 16WV	
C220			CC73FCH1H220J	CHIP C 22PF J		C530			CK73GB1E123K	CHIP C 0.012UF K	
C221			CK73GB1H102K	CHIP C 1000PF K		C531			C92-0560-05	CHIP-TAN 10UF 6.3WV	
C222			C92-0044-05	CHIP-ELE 47UF 10WV		C532			CK73GB1H222K	CHIP C 2200PF K	
C223			CK73GB1H102K	CHIP C 1000PF K		C533			C92-0560-05	CHIP-TAN 10UF 6.3WV	
C224			CK73FB1E104K	CHIP C 0.10UF K		C534			CK73FB1E104K	CHIP C 0.10UF K	
C225-227			CK73GB1H102K	CHIP C 1000PF K		C535			C92-0560-05	CHIP-TAN 10UF 6.3WV	
C301,302			CK73GB1H102K	CHIP C 1000PF K		C536,537			CK73FB1E104K	CHIP C 0.10UF K	
C303			CK73GB1H103K	CHIP C 0.010UF K		C538			CK73GB1E223K	CHIP C 0.022UF K	
C304			CK73FB1E104K	CHIP C 0.10UF K		C539			CC73GCH1H470J	CHIP C 47PF J	
C305			CK73GB1H102K	CHIP C 1000PF K		C540			CK73FB1E104K	CHIP C 0.10UF K	
C306,307			CK73GB1H103K	CHIP C 0.010UF K		C541			CK73GB1H102K	CHIP C 1000PF K	
C308,309			CK73FB1E104K	CHIP C 0.10UF K		C542			CK73FB1E104K	CHIP C 0.10UF K	
C310			C92-0633-05	CHIP-TAN 22UF 10WV		C543			CK73GB1H102K	CHIP C 1000PF K	
C311			C90-4016-05	ELECTRO 47UF 16WV		C544			CC73GCH1H121J	CHIP C 120PF J	
C312			C92-0001-05	CHIP C 0.1UF 35WV		C545			CK73GB1E103K	CHIP C 0.010UF K	
C313			C92-1341-05	ELECTRO 100UF 16WV		C546			CK73FB1E104K	CHIP C 0.10UF K	
C314			C90-4016-05	ELECTRO 47UF 16WV		C547			CK73GB1E223K	CHIP C 0.022UF K	
C315			CC73GCH1H100D	CHIP C 10PF D		C548			C92-0507-05	CHIP-TAN 4.7UF 6.3WV	
C316,317			CK73GB1H103K	CHIP C 0.010UF K		C549			CK73GB1H222K	CHIP C 2200PF K	
C318,319			C92-0514-05	CHIP-TAN 2.2UF 10WV		C550			CK73FB1E104K	CHIP C 0.10UF K	
C320			CK73FB1E224K	CHIP C 0.22UF K		C551			CK73FB1E333K	CHIP C 0.033UF K	
C321			C92-0003-05	CHIP-TAN 0.47UF 25WV		C552			CC73GCH1H470J	CHIP C 47PF J	
C322			CK73GB1H102K	CHIP C 1000PF K		C553,554			CK73FB1E104K	CHIP C 0.10UF K	
C323			CC73GCH1H240J	CHIP C 24PF J		C555			CK73GB1H102K	CHIP C 1000PF K	
C324			CK73GB1H102K	CHIP C 1000PF K		C557			CK73GB1E223K	CHIP C 0.022UF K	
C325			CC73GCH1H360J	CHIP C 36PF J		C558			C92-0507-05	CHIP-TAN 4.7UF 6.3WV	
C326			CC73GCH1H050C	CHIP C 5.0PF C		C559			C92-0036-05	CHIP-ELE 4.7UF 16WV	
C327			CC73GCH1H470J	CHIP C 47PF J		C562			CK73GB1E103K	CHIP C 0.010UF K	
C328			CC73GCH1H180G	CHIP C 18PF G		C563			CK73GB1H102K	CHIP C 1000PF K	
C329			CK73GB1H102K	CHIP C 1000PF K		C565			C92-0003-05	CHIP-TAN 0.47UF 25WV	
C330			CC73GCH1HR75C	CHIP C 0.75PF C		C566			CC73GCH1H100D	CHIP C 10PF D	
C331			CC73GCH1H150J	CHIP C 15PF J		C567			CK73GB1E223K	CHIP C 0.022UF K	
C332			CK73FB1C474K	CHIP C 0.47UF K		C568			CK73GB1H102K	CHIP C 1000PF K	
C333			CC73GCH1H150J	CHIP C 15PF J		C570			C92-0036-05	CHIP-ELE 4.7UF 16WV	
C334,335			CC73GCH1H120J	CHIP C 12PF J		C571			C92-0585-05	CHIP-TAN 4.7UF 16WV	
C336			CC73GCH1H150J	CHIP C 15PF J		C572,573			CC73GCH1H030C	CHIP C 3.0PF C	
C337-339			CK73GB1H102K	CHIP C 1000PF K		C574			CK73GB1H472K	CHIP C 4700PF K	
C340,341			CC73GCH1H020C	CHIP C 2.0PF C		C575			C92-0628-05	CHIP-TAN 10UF 10WV	
C342,343			CK73GB1H102K	CHIP C 1000PF K		C576			CC73GCH1H470J	CHIP C 47PF J	
C344			CC73GCH1H100D	CHIP C 10PF D		C578			C92-0507-05	CHIP-TAN 4.7UF 6.3WV	
C345-349			CK73GB1H102K	CHIP C 1000PF K		C579			CK73GB1H472K	CHIP C 4700PF K	
C350			CC73GCH1H470J	CHIP C 47PF J		C580-582			CK73GB1H102K	CHIP C 1000PF K	
C351-355			CK73GB1H102K	CHIP C 1000PF K		C583			C92-0546-05	CHIP-TAN 68UF 6.3WV	
C356			C92-0606-05	CHIP-TAN 4.7UF 10WV		C584			CK73FB1E104K	CHIP C 0.10UF K	
C357			C92-0560-05	CHIP-TAN 10UF 6.3WV		C585			CC73FCH1H751J	CHIP C 750PF J	
C358			CK73GB1H102K	CHIP C 1000PF K		C586			CC73GCH1H180J	CHIP C 18PF J	
C359			CC73GCH1H100D	CHIP C 10PF D		C587			CK73GB1H122K	CHIP C 1200PF K	
C360			CC73GCH1H050C	CHIP C 5.0PF C		C588			CC73GCH1H070D	CHIP C 7.0PF D	
C361			CK73FB1C474K	CHIP C 0.47UF K		C589			CC73GCH1H181J	CHIP C 180PF J	
C362			CC73GCH1H270J	CHIP C 27PF J		C590			CK73GB1H332K	CHIP C 3300PF K	
C363,364			CC73GCH1H030C	CHIP C 3.0PF C		C591			CC73GCH1H180J	CHIP C 18PF J	
C365,366			CC73GCH1H150J	CHIP C 15PF J		C592			CK73GB1H102K	CHIP C 1000PF K	
C370			CK73GB1H102K	CHIP C 1000PF K		C593			C92-0633-05	CHIP-TAN 22UF 10WV	
C371			CK73FB1H473K	CHIP C 0.047UF K		C594			CK73GB1E103K	CHIP C 0.010UF K	
C501			CC73GCH1H101J	CHIP C 100PF J		C595-597			CK73GB1H102K	CHIP C 1000PF K	
C524			CK73GB1H102K	CHIP C 1000PF K		C598,599			CK73FB1E104K	CHIP C 0.10UF K	

# TK-790/(B)/H(B)

## PARTS LIST

TX-RX UNIT (X57-5610-12) : TK-790H(B)

Ref. No.	Address	New parts	Parts No.	Description	Destination	Ref. No.	Address	New parts	Parts No.	Description	Destination
C600			C92-0507-05	CHIP-TAN 4.7UF 6.3WV		CN102,103			E40-5538-05	PIN ASSY	
C601			CK73GB1H102K	CHIP C 1000PF K		CN104			E04-0154-05	PIN SOCKET	
C602			CK73GB1H562K	CHIP C 5600PF K		CN201			E40-5752-05	PIN ASSY	
C603			CK73GB1H102K	CHIP C 1000PF K		CN202			E40-5978-05	FLAT CABLE CONNECTOR	
C604,605			CK73GB1H562K	CHIP C 5600PF K		CN203			E04-0154-05	PIN SOCKET	
C606			C92-0507-05	CHIP-TAN 4.7UF 6.3WV		CN501			E40-5703-05	PIN ASSY	
C607			CK73GB1H102K	CHIP C 1000PF K		CN504			E40-5661-05	PIN ASSY SOCKET	
C608			CK73GB1H332J	CHIP C 3300PF J		CN505			E40-5960-05	PIN ASSY	
C609			CK73GB1H272J	CHIP C 2700PF J		CN506			E40-5066-05	PIN ASSY	
C610			CK73FB1E104K	CHIP C 0.10UF K		CN507			E40-5751-05	PIN ASSY	
C611			CK73GB1H272J	CHIP C 2700PF J		CN508			E40-5701-05	PIN ASSY	
C612			C92-1341-05	ELECTRO 100UF 16WV		W501			E37-0707-05	LEAD WIRE WITH CONNECTOR	
C613			C92-0040-05	CHIP-ELE 47UF 16WV		A102			F10-2278-04	SHIELDING PLATE (MCF)	
C614			CK73GB1H102K	CHIP C 1000PF K		F501			F53-0128-05	FUSE (0.5A)	
C615			CK73GB1H272J	CHIP C 2700PF J		F502			F53-0108-05	FUSE (1.8A)	
C616			CK73GB1E103K	CHIP C 0.010UF K		CF101			L72-0916-05	CERAMIC FILTER (455KHZ)	
C617			CK73FB1E104K	CHIP C 0.10UF K		CF102			L72-0939-05	CERAMIC FILTER (455KHZ)	
C618			CK73GB1H272J	CHIP C 2700PF J		CF103			L72-0916-05	CERAMIC FILTER (455KHZ)	
C619			C92-0721-05	ELECTRO 330UF 25WV		CF104			L72-0939-05	CERAMIC FILTER (455KHZ)	
C620			CK73GB1E103K	CHIP C 0.010UF K		L101			L40-8272-48	SMALL FIXED INDUCTOR	
C621			CK73FB1E104K	CHIP C 0.10UF K		L102			L40-3382-48	SMALL FIXED INDUCTOR	
C622			CK73GB1H102K	CHIP C 1000PF K		L103			L40-3372-48	SMALL FIXED INDUCTOR	
C623			C92-0040-05	CHIP-ELE 47UF 16WV		L104			L40-3382-48	SMALL FIXED INDUCTOR	
C624			CK73GB1H102K	CHIP C 1000PF K		L105			L40-8272-48	SMALL FIXED INDUCTOR	
C625			CK73GB1E103K	CHIP C 0.010UF K		L107			L40-2782-48	SMALL FIXED INDUCTOR	
C626			C92-0004-05	CHIP-TAN 1.0UF 16WV		L109			L40-6885-34	SMALL FIXED INDUCTOR (680NH)	
C627,628			CK73FB1E104K	CHIP C 0.10UF K		L110-112			L34-4080-05	COIL	
C629,630			CK73GB1H102K	CHIP C 1000PF K		L114,115			L40-3375-34	SMALL FIXED INDUCTOR (33NH)	
C631			CC73GCH1H101J	CHIP C 100PF J		L117			L34-4527-05	COIL	
C632-639			CK73GB1H102K	CHIP C 1000PF K		L118,119			L34-4526-05	COIL	
C640			C92-0560-05	CHIP-TAN 10UF 6.3WV		L120			L34-4527-05	COIL	
C641,642			CK73FB1E104K	CHIP C 0.10UF K		L121			L40-3975-34	SMALL FIXED INDUCTOR (39NH)	
C666-680			CC73GCH1H101J	CHIP C 100PF J		L122			L34-4526-05	COIL	
C681			CK73GB1H102K	CHIP C 1000PF K		L123			L34-4527-05	COIL	
C682,683			CC73GCH1H101J	CHIP C 100PF J		L126			L40-1095-34	SMALL FIXED INDUCTOR (1UH)	
C684			CK73GB1H102K	CHIP C 1000PF K		L127			L34-4530-05	COIL	
C685			CC73GCH1H101J	CHIP C 100PF J		L128			L40-1885-34	SMALL FIXED INDUCTOR (180NH)	
C686			CK73GB1H102K	CHIP C 1000PF K		L129			L40-1281-37	SMALL FIXED INDUCTOR (0.120UH)	
C687			CK73GB1E103K	CHIP C 0.010UF K		L130			L40-3381-37	SMALL FIXED INDUCTOR (0.330UH)	
C688,689			CC73GCH1H101J	CHIP C 100PF J		L131			L40-3375-34	SMALL FIXED INDUCTOR (33NH)	
C690			CK73FB1E104K	CHIP C 0.10UF K		L132,133			L40-2772-48	SMALL FIXED INDUCTOR	
C691,692			CC73GCH1H101J	CHIP C 100PF J		L134			L40-1095-34	SMALL FIXED INDUCTOR (1UH)	
C693			CK73GB1E103K	CHIP C 0.010UF K		L135,136			L40-1005-34	SMALL FIXED INDUCTOR (10UH)	
C694			C92-0633-05	CHIP-TAN 22UF 10WV		L201			L40-6875-34	SMALL FIXED INDUCTOR (68NH)	
C695			CC73GCH1H101J	CHIP C 100PF J		L202			L40-8271-34	SMALL FIXED INDUCTOR (82NH)	
C696			C92-0628-05	CHIP-TAN 10UF 10WV		L301-304			L33-1268-15	SMALL FIXED INDUCTOR	
C697			CK73GB1E103K	CHIP C 0.010UF K		L305,306	*		L34-4592-05	AIR-CORE COIL	
C698-700			C92-0560-05	CHIP-TAN 10UF 6.3WV		L307-309			L33-1268-15	SMALL FIXED INDUCTOR	
C701			C92-0566-05	CHIP-TAN 10UF 6.3WV		L310			L40-8271-34	SMALL FIXED INDUCTOR (82NH)	
C703-705			CK73FB1E104K	CHIP C 0.10UF K		L311			L40-1085-34	SMALL FIXED INDUCTOR (100NH)	
C706			C92-0507-05	CHIP-TAN 4.7UF 6.3WV		L312			L92-0148-05	FERRITE CHIP	
C707			CC73GCH1H560J	CHIP C 56PF J		L313,314			L40-3975-34	SMALL FIXED INDUCTOR (39NH)	
C708			CK73FB1E104K	CHIP C 0.10UF K		L501,502			L40-1005-34	SMALL FIXED INDUCTOR (10UH)	
C709			CC73GCH1H560J	CHIP C 56PF J		X101			L77-1736-05	CRYSTAL RESONATOR (45.305MHZ)	
C710			CK73GB1E123K	CHIP C 0.012UF K		X301	*		L77-1798-05	VXCO (16.8MHZ)	
C711			CC73GCH1H101J	CHIP C 100PF J		X501			L77-1708-05	CRYSTAL RESONATOR (3.579545MHZ)	
C712			CK73GB1E473J	CHIP C 0.047UF J		X502			L77-1863-05	CRYSTAL RESONATOR (12.0MHZ)	
TC301,302			C05-0393-05	CERAMIC TRIMMER CAP (8PF)		XF101			L71-0512-05	MCF (44.85MHZ WIDE)	
CN101			E04-0154-05	PIN SOCKET		XF102			L71-0513-05	MCF (44.85MHZ NARROW)	

## PARTS LIST

TX-RX UNIT (X57-5610-12) : TK-790H(B)

Ref. No.	Address	New parts	Parts No.	Description	Desti-nation	Ref. No.	Address	New parts	Parts No.	Description	Desti-nation
R101			RK73GB1J470J	CHIP R 47 J 1/16W		R209			RK73GB1J560J	CHIP R 56 J 1/16W	
R102			RK73GB1J472J	CHIP R 4.7K J 1/16W		R210			RK73GB1J470J	CHIP R 47 J 1/16W	
R103			RK73GB1J102J	CHIP R 1.0K J 1/16W		R211			RK73GB1J152J	CHIP R 1.5K J 1/16W	
R104			RK73GB1J120J	CHIP R 12 J 1/16W		R212			RK73GB1J472J	CHIP R 4.7K J 1/16W	
R105			RK73GB1J821J	CHIP R 820 J 1/16W		R213			RK73GB1J473J	CHIP R 47K J 1/16W	
R106			RK73GB1J330J	CHIP R 33 J 1/16W		R214			RK73GB1J100J	CHIP R 10 J 1/16W	
R107			RK73GB1J821J	CHIP R 820 J 1/16W		R215			RK73GB1J473J	CHIP R 47K J 1/16W	
R108			RK73GB1J334J	CHIP R 330K J 1/16W		R216			R92-0685-05	CHIP R 22 J 1/2W	
R109			RK73GB1J332J	CHIP R 3.3K J 1/16W		R217			RK73GB1J472J	CHIP R 4.7K J 1/16W	
R110,111			RK73GB1J104J	CHIP R 100K J 1/16W		R218			RK73FB2A821J	CHIP R 820 J 1/10W	
R112			RK73GB1J102J	CHIP R 1.0K J 1/16W		R219,220			RK73FB2A100J	CHIP R 10 J 1/10W	
R113-115			RK73GB1J104J	CHIP R 100K J 1/16W		R221			RK73FB2A821J	CHIP R 820 J 1/10W	
R116			R92-1252-05	CHIP R 0 OHM		R301-304			RK73GB1J103J	CHIP R 10K J 1/16W	
R117			RK73GB1J101J	CHIP R 100 J 1/16W		R305			R92-1252-05	CHIP R 0 OHM	
R118			RK73GB1J473J	CHIP R 47K J 1/16W		R306			RK73GB1J560J	CHIP R 56 J 1/16W	
R119			RK73GB1J560J	CHIP R 56 J 1/16W		R307,308			RK73GB1J100J	CHIP R 10 J 1/16W	
R120			RK73GB1J102J	CHIP R 1.0K J 1/16W		R309			R92-1252-05	CHIP R 0 OHM	
R121			RK73FB2A821J	CHIP R 820 J 1/10W		R310,311			RK73GB1J152J	CHIP R 1.5K J 1/16W	
R122			RK73FB2A5R6J	CHIP R 5.6 J 1/10W		R312			RK73GB1J682J	CHIP R 6.8K J 1/16W	
R123			RK73GB1J270J	CHIP R 27 J 1/16W		R313			RK73GB1J223J	CHIP R 22K J 1/16W	
R124			RK73FB2A821J	CHIP R 820 J 1/10W		R314,315			RK73GB1J221J	CHIP R 220 J 1/16W	
R125-127			RK73GB1J222J	CHIP R 2.2K J 1/16W		R316			RK73GB1J222J	CHIP R 2.2K J 1/16W	
R128			RK73GB1J223J	CHIP R 22K J 1/16W		R317			RK73GB1J474J	CHIP R 470K J 1/16W	
R129			R92-1252-05	CHIP R 0 OHM		R318			RK73FB2A152J	CHIP R 1.5K J 1/10W	
R132			RK73GB1J103J	CHIP R 10K J 1/16W		R319			RK73GB1J102J	CHIP R 1.0K J 1/16W	
R133			RK73GB1J472J	CHIP R 4.7K J 1/16W		R320-323			R92-1252-05	CHIP R 0 OHM	
R134			RK73GB1J330J	CHIP R 33 J 1/16W		R324			RK73GB1J223J	CHIP R 22K J 1/16W	
R135			RK73GB1J220J	CHIP R 22 J 1/16W		R325			RK73GB1J103J	CHIP R 10K J 1/16W	
R136-138			RK73GB1J222J	CHIP R 2.2K J 1/16W		R326			RK73GB1J330J	CHIP R 33 J 1/16W	
R139			RK73GB1J473J	CHIP R 47K J 1/16W		R327			RK73GB1J104J	CHIP R 100K J 1/16W	
R141			RK73GB1J102J	CHIP R 1.0K J 1/16W		R328			RK73GB1J330J	CHIP R 33 J 1/16W	
R142			RK73GB1J472J	CHIP R 4.7K J 1/16W		R329			RK73GB1J471J	CHIP R 470 J 1/16W	
R143			RK73GB1J470J	CHIP R 47 J 1/16W		R330			RK73GB1J331J	CHIP R 330 J 1/16W	
R144			RK73GB1J153J	CHIP R 15K J 1/16W		R331,332			RK73GB1J472J	CHIP R 4.7K J 1/16W	
R145,146			RK73GB1J223J	CHIP R 22K J 1/16W		R333			RK73GB1J470J	CHIP R 47 J 1/16W	
R148			RK73GB1J223J	CHIP R 22K J 1/16W		R334			RK73GB1J472J	CHIP R 4.7K J 1/16W	
R149			RK73GB1J274J	CHIP R 270K J 1/16W		R335			RK73GB1J470J	CHIP R 47 J 1/16W	
R150,151			RK73GB1J223J	CHIP R 22K J 1/16W		R336,337			RK73GB1J472J	CHIP R 4.7K J 1/16W	
R152			RK73GB1J472J	CHIP R 4.7K J 1/16W		R338			RK73GB1J473J	CHIP R 47K J 1/16W	
R153			RK73GB1J182J	CHIP R 1.8K J 1/16W		R339			RK73GB1J103J	CHIP R 10K J 1/16W	
R155			RK73GB1J472J	CHIP R 4.7K J 1/16W		R340			RK73GB1J330J	CHIP R 33 J 1/16W	
R156,157			RK73GB1J332J	CHIP R 3.3K J 1/16W		R341			RK73GB1J331J	CHIP R 330 J 1/16W	
R158			RK73GB1J821J	CHIP R 820 J 1/16W		R342			RK73GB1J223J	CHIP R 22K J 1/16W	
R159			RK73GB1J5R6J	CHIP R 5.6 J 1/16W		R343			RK73GB1J103J	CHIP R 10K J 1/16W	
R160			RK73GB1J821J	CHIP R 820 J 1/16W		R344			RK73GB1J223J	CHIP R 22K J 1/16W	
R161			R92-1252-05	CHIP R 0 OHM		R345			RK73GB1J103J	CHIP R 10K J 1/16W	
R162			RK73GB1J682J	CHIP R 6.8K J 1/16W		R346			RK73GB1J330J	CHIP R 33 J 1/16W	
R163			RK73GB1J182J	CHIP R 1.8K J 1/16W		R347			RK73GB1J471J	CHIP R 470 J 1/16W	
R164			RK73GB1J101J	CHIP R 100 J 1/16W		R348			RK73GB1J331J	CHIP R 330 J 1/16W	
R165			RK73GB1J393J	CHIP R 39K J 1/16W		R349			RK73GB1J330J	CHIP R 33 J 1/16W	
R166			RK73GB1J220J	CHIP R 22 J 1/16W		R350			RK73GB1J101J	CHIP R 100 J 1/16W	
R167			RK73GB1J102J	CHIP R 1.0K J 1/16W		R351,352			RK73GB1J102J	CHIP R 1.0K J 1/16W	
R201			RK73GB1J271J	CHIP R 270 J 1/16W		R354,355			RK73GB1J220J	CHIP R 22 J 1/16W	
R202			RK73GB1J180J	CHIP R 18 J 1/16W		R357			R92-1252-05	CHIP R 0 OHM	
R203			RK73GB1J102J	CHIP R 1.0K J 1/16W		R358			RK73GB1J331J	CHIP R 330 J 1/16W	
R204			RK73GB1J271J	CHIP R 270 J 1/16W		R361			RK73GB1J102J	CHIP R 1.0K J 1/16W	
R205			RK73GB1J222J	CHIP R 2.2K J 1/16W		R366			R92-1252-05	CHIP R 0 OHM	
R206			RK73GB1J103J	CHIP R 10K J 1/16W		R501			RK73GB1J333J	CHIP R 33K J 1/16W	
R207			RK73GB1J100J	CHIP R 10 J 1/16W		R502			RK73GB1J471J	CHIP R 470 J 1/16W	
R208			RK73GB1J222J	CHIP R 2.2K J 1/16W		R504			R92-0670-05	CHIP R 0 OHM	

# TK-790/(B)/H(B)

## PARTS LIST

TX-RX UNIT (X57-5610-12) : TK-790H(B)

Ref. No.	Address	New parts	Parts No.	Description	Destination	Ref. No.	Address	New parts	Parts No.	Description	Destination
R505			RK73GB1J103J	CHIP R 10K J 1/16W		R584			RK73GB1J333J	CHIP R 33K J 1/16W	
R507			RK73GB1J223J	CHIP R 22K J 1/16W		R586			RK73GB1J104J	CHIP R 100K J 1/16W	
R508			RK73GB1J102J	CHIP R 1.0K J 1/16W		R587			R92-0670-05	CHIP R 0 OHM	
R509-511			RK73GB1J473J	CHIP R 47K J 1/16W		R588			RK73GB1J473J	CHIP R 47K J 1/16W	
R512			RK73GB1J184J	CHIP R 180K J 1/16W		R589			RK73GB1J223J	CHIP R 22K J 1/16W	
R513			RK73GB1J223J	CHIP R 22K J 1/16W		R591,592			RK73GB1J124J	CHIP R 120K J 1/16W	
R514			RK73GB1J184J	CHIP R 180K J 1/16W		R594-597			RK73GB1J473J	CHIP R 47K J 1/16W	
R515			R92-0670-05	CHIP R 0 OHM		R598			RK73GB1J332J	CHIP R 3.3K J 1/16W	
R516			RK73GB1J104J	CHIP R 100K J 1/16W		R599,600			RK73GB1J473J	CHIP R 47K J 1/16W	
R517		*	RK73GH1J104D	CHIP R 100K D 1/16W		R601			RK73GB1J472J	CHIP R 4.7K J 1/16W	
R518			R92-1252-05	CHIP R 0 OHM		R602			RK73FB2A473J	CHIP R 47K J 1/10W	
R519			RK73GB1J104J	CHIP R 100K J 1/16W		R603			RK73GB1J103J	CHIP R 10K J 1/16W	
R520		*	RK73GH1J334D	CHIP R 330K D 1/16W		R604			R92-0670-05	CHIP R 0 OHM	
R521			RK73GB1J102J	CHIP R 1.0K J 1/16W		R605			RK73GB1J333J	CHIP R 33K J 1/16W	
R522			RK73GH1J913D	CHIP R 91K D 1/16W		R606			RK73GB1J154J	CHIP R 150K J 1/16W	
R523			RK73GB1J474J	CHIP R 470K J 1/16W		R607			R92-1252-05	CHIP R 0 OHM	
R524			RK73GH1J224D	CHIP R 220K D 1/16W		R608			RK73GB1J123J	CHIP R 12K J 1/16W	
R525			RK73GB1J472J	CHIP R 4.7K J 1/16W		R609			RK73GB1J153J	CHIP R 15K J 1/16W	
R526			RK73GB1J104J	CHIP R 100K J 1/16W		R611			RK73GB1J474J	CHIP R 470K J 1/16W	
R527			RK73GB1J223J	CHIP R 22K J 1/16W		R612			RK73GB1J823J	CHIP R 82K J 1/16W	
R528			RK73GB1J104J	CHIP R 100K J 1/16W		R613			RK73GB1J393J	CHIP R 39K J 1/16W	
R529,530			RK73GB1J334J	CHIP R 330K J 1/16W		R615			RK73GB1J122J	CHIP R 1.2K J 1/16W	
R531			RK73GB1J154J	CHIP R 150K J 1/16W		R616			RK73GB1J152J	CHIP R 1.5K J 1/16W	
R532			RK73GB1J474J	CHIP R 470K J 1/16W		R617			RN73GH1J274D	CHIP R 270K D 1/16W	
R533			RN73GH1J473D	CHIP R 47K D 1/16W		R618			RN73GH1J334D	CHIP R 330K D 1/16W	
R534			RN73GH1J563D	CHIP R 56K D 1/16W		R619,620			RN73GH1J274D	CHIP R 270K D 1/16W	
R535			RK73GB1J103J	CHIP R 10K J 1/16W		R621			RK73GB1J472J	CHIP R 4.7K J 1/16W	
R536			RK73GB1J681J	CHIP R 680 J 1/16W		R622			RK73GB1J473J	CHIP R 47K J 1/16W	
R537			RK73GB1J472J	CHIP R 4.7K J 1/16W		R623			RN73GH1J274D	CHIP R 270K D 1/16W	
R539			RK73GB1J561J	CHIP R 560 J 1/16W		R624			RK73GB1J103J	CHIP R 10K J 1/16W	
R541			R92-0670-05	CHIP R 0 OHM		R625			RK73GB1J684J	CHIP R 680K J 1/16W	
R542			RK73GB1J470J	CHIP R 47 J 1/16W		R626			RK73GB1J822J	CHIP R 8.2K J 1/16W	
R543			RK73GB1J220J	CHIP R 22 J 1/16W		R627			RN73GH1J274D	CHIP R 270K D 1/16W	
R545			RK73GB1J564J	CHIP R 560K J 1/16W		R628			R92-0670-05	CHIP R 0 OHM	
R546			R92-0670-05	CHIP R 0 OHM		R629			RN73GH1J563D	CHIP R 56K D 1/16W	
R547			R92-1252-05	CHIP R 0 OHM		R630			RN73GH1J473D	CHIP R 47K D 1/16W	
R549			RK73GB1J153J	CHIP R 15K J 1/16W		R631			RK73GB1J104J	CHIP R 100K J 1/16W	
R550			RK73GB1J683J	CHIP R 68K J 1/16W		R632			RK73GB1J102J	CHIP R 1.0K J 1/16W	
R552			RK73GB1J101J	CHIP R 100 J 1/16W		R633,634			RK73GB1J103J	CHIP R 10K J 1/16W	
R553			RK73GB1J822J	CHIP R 8.2K J 1/16W		R635			R92-0670-05	CHIP R 0 OHM	
R557,558			RK73GB1J104J	CHIP R 100K J 1/16W		R636		*	RK73GH1J104D	CHIP R 100K	
R559			RK73GB1J473J	CHIP R 47K J 1/16W		R638			RK73GH1J223D	CHIP R 22K	
R561			RK73GB1J102J	CHIP R 1.0K J 1/16W		R639			RK73GB1J473J	CHIP R 47K J 1/16W	
R562			RK73GB1J274J	CHIP R 270K J 1/16W		R641			R92-0670-05	CHIP R 0 OHM	
R563			RK73GB1J104J	CHIP R 100K J 1/16W		R642-648			RK73FB2A102J	CHIP R 1.0K J 1/10W	
R564			RK73GB1J474J	CHIP R 470K J 1/16W		R652			RK73FB2A102J	CHIP R 1.0K J 1/10W	
R565			RK73GB1J123J	CHIP R 12K J 1/16W		R654-656			RK73FB2A102J	CHIP R 1.0K J 1/10W	
R566			RK73GB1J153J	CHIP R 15K J 1/16W		R657			R92-0670-05	CHIP R 0 OHM	
R567			RK73GB1J224J	CHIP R 220K J 1/16W		R658			RK73GB1J473J	CHIP R 47K J 1/16W	
R568			R92-1252-05	CHIP R 0 OHM		R659			RK73GB1J563J	CHIP R 56K J 1/16W	
R570			RK73GB1J223J	CHIP R 22K J 1/16W		R661			R92-0670-05	CHIP R 0 OHM	
R572			RK73GB1J104J	CHIP R 100K J 1/16W		R662			RK73GB1J472J	CHIP R 4.7K J 1/16W	
R573			RK73GB1J274J	CHIP R 270K J 1/16W		R663			RK73GB1J473J	CHIP R 47K J 1/16W	
R574			RK73GB1J102J	CHIP R 1.0K J 1/16W		R664			RK73GB1J333J	CHIP R 33K J 1/16W	
R575,576			RK73GB1J104J	CHIP R 100K J 1/16W		R665			RK73GB1J104J	CHIP R 100K J 1/16W	
R577			RK73GB1J122J	CHIP R 1.2K J 1/16W		R666,667			R92-0670-05	CHIP R 0 OHM	
R578			RK73GB1J102J	CHIP R 1.0K J 1/16W		R668			R92-1252-05	CHIP R 0 OHM	
R579,580			RK73GB1J823J	CHIP R 82K J 1/16W		R670			R92-0670-05	CHIP R 0 OHM	
R581,582			RK73GB1J683J	CHIP R 68K J 1/16W		R671			RK73GB1J683J	CHIP R 68K J 1/16W	
R583			R92-0670-05	CHIP R 0 OHM		R672			RK73GB1J473J	CHIP R 47K J 1/16W	

## PARTS LIST

TX-RX UNIT (X57-5610-12) : TK-790H(B)

Ref. No.	Address	New parts	Parts No.	Description	Destination	Ref. No.	Address	New parts	Parts No.	Description	Destination
R674,675			RK73GB1J472J	CHIP R 4.7K J 1/16W		D521			DA204U	DIODE	
R676			RK73GB1J473J	CHIP R 47K J 1/16W		D523,524			DA204U	DIODE	
R677			RK73GB1J472J	CHIP R 4.7K J 1/16W		D526,527			DA204U	DIODE	
R678,679			RK73GB1J332J	CHIP R 3.3K J 1/16W		D528,529			1SS355	DIODE	
R680			RK73GB1J104J	CHIP R 100K J 1/16W		IC101			TA31136FN	IC (FM IC)	
R690,691			R92-0670-05	CHIP R 0 OHM		IC201			BU4094BCF	IC (SHIFT REGISTER)	
R693			RK73GB1J103J	CHIP R 10K J 1/16W		IC202			NJM78L05UA	IC (AVR)	
R695			R92-1252-05	CHIP R 0 OHM		IC203			AN8009M	IC (AVR)	
R697			R92-1252-05	CHIP R 0 OHM		IC301			SA7025DK	IC (PLL IC)	
R698			RK73GB1J472J	CHIP R 4.7K J 1/16W		IC501			TC4013BF(N)	IC (D FF)	
R699			R92-1252-05	CHIP R 0 OHM		IC502			NJM4558M	IC (LPF)	
R700			RK73GB1J220J	CHIP R 22 J 1/16W		IC503			TA7808S	IC (AVR)	
R701			RK73GB1J103J	CHIP R 10K J 1/16W		IC504			TC35453F	IC (AUDIO PROCESSOR)	
R702			RK73GB1J472J	CHIP R 4.7K J 1/16W		IC505			NJM4558M	IC (HPF/IDC)	
R703			RK73GB1J473J	CHIP R 47K J 1/16W		IC506			L78LR05B-FA	IC (AVR)	
R706			R92-0670-05	CHIP R 0 OHM		IC508			NJM4558M	IC (LIMITER/BUFFER AMP)	
R707-713			RK73GB1J474J	CHIP R 470K J 1/16W		IC509			MC33172D	IC (BUFFER AMP)	
R714			RK73GB1J104J	CHIP R 100K J 1/16W		IC510			NJM4558M	IC (SUMMING AMP/LPF)	
R715			RK73GB1J474J	CHIP R 470K J 1/16W		IC511			PCD3312CT	IC (DTMF ENCODER)	
R716			RK73GB1J104J	CHIP R 100K J 1/16W		IC512			M62364FP	IC (D/A CONVERTER)	
R717			RK73GB1J102J	CHIP R 1.0K J 1/16W		IC513			NJM4558M	IC (LPF/SUMMING AMP)	
R718			RK73GB1J333J	CHIP R 33K J 1/16W		IC514			AT24C64N10SI27	IC (EEPROM)	
R719			RS14DB3D2R2J	FL-PROOF RS 2.2 J 2W		IC515			BU4066BCF	IC (ANALOG SWITCH)	
R720			R92-0670-05	CHIP R 0 OHM		IC516	*		784214GC0518EU	IC (CPU)	
R721			RK73GB1J393J	CHIP R 39K J 1/16W		IC517			BU4094BCF	IC (SHIFT REGISTER)	
R722			RK73GB1J184J	CHIP R 180K J 1/16W		IC518			NJM4558M	IC (BUFFER AMP)	
R723			R92-0670-05	CHIP R 0 OHM		IC519			AT29C020-90TI	IC (FLASH ROM)	
R724			RK73GB1J683J	CHIP R 68K J 1/16W		IC520			TC7S02F	IC (NOR GATE)	
R725			RK73GB1J333J	CHIP R 33K J 1/16W		IC521			NJM4558M	IC (BUFFER AMP)	
R726			RK73GB1J122J	CHIP R 1.2K J 1/16W		IC522			TDA8561Q	IC (AUDIO POWER AMP)	
R727			RK73GB1J473J	CHIP R 47K J 1/16W		IC523			BU4094BCF	IC (SHIFT REGISTER)	
R728			R92-0670-05	CHIP R 0 OHM		IC524			NJM4558M	IC (BUFFER AMP/DE-EMPHASIS)	
R729-736			RK73GB1J472J	CHIP R 4.7K J 1/16W		IC525			LC73872M	IC (DTMF DECODER)	
R740,741			RK73GB1J103J	CHIP R 10K J 1/16W		IC526			TA75S01F	IC (COMPANDER AMP)	
R742			R92-0670-05	CHIP R 0 OHM		Q101,102			2SC3357	TRANSISTOR	
R744			RK73GB1J104J	CHIP R 100K J 1/16W		Q104			2SC3357	TRANSISTOR	
R746			R92-1252-05	CHIP R 0 OHM		Q105			DTA144EUA	DIGITAL TRANSISTOR	
R747			R92-0670-05	CHIP R 0 OHM		Q106			DTC144EUA	DIGITAL TRANSISTOR	
R748			R92-1252-05	CHIP R 0 OHM		Q107			2SC4215(Y)	TRANSISTOR	
VR501			R12-6417-05	TRIMMING POT. (1K)		Q108			DTC144EUA	DIGITAL TRANSISTOR	
D101			1SS355	DIODE		Q109			2SC4617(S)	TRANSISTOR	
D102			1SV269	VARIABLE CAPACITANCE DIODE		Q201			2SC3357	TRANSISTOR	
D103			MA742	DIODE		Q202			2SB1132(Q,R)	TRANSISTOR	
D104,105			1SV269	VARIABLE CAPACITANCE DIODE		Q203			DTC114EUA	DIGITAL TRANSISTOR	
D106-109			DAN235K	DIODE		Q204			2SC2954	TRANSISTOR	
D201,202			DA204K	DIODE		Q205			DTC114EUA	DIGITAL TRANSISTOR	
D301-304			1SV282	VARIABLE CAPACITANCE DIODE		Q206			2SB1132(Q,R)	TRANSISTOR	
D305			1SV214	VARIABLE CAPACITANCE DIODE		Q301,302			2SC4116(GR)	TRANSISTOR	
D306			DAN235K	DIODE		Q303,304			2SC3722(K,S)	TRANSISTOR	
D501			Q2CZ18(X,Y)	ZENER DIODE		Q305,306			2SK508NV(K52)	FET	
D502,503			1SS355	DIODE		Q307,308			2SC4116(Y)	TRANSISTOR	
D504			Q2CZ5.6(X,Y)	ZENER DIODE		Q309			DTC114EUA	DIGITAL TRANSISTOR	
D505			1SS355	DIODE		Q310,311			2SC4215(Y)	TRANSISTOR	
D506			1SS301	DIODE		Q312			2SC3120	TRANSISTOR	
D507			Q2CZ15(X,Y)	ZENER DIODE		Q501			DTA114EUA	DIGITAL TRANSISTOR	
D508			1SS355	DIODE		Q502,503			DTC114EUA	DIGITAL TRANSISTOR	
D511			1SS301	DIODE		Q504			DTC363EK	DIGITAL TRANSISTOR	
D512			1SS355	DIODE		Q505			DTC144EUA	DIGITAL TRANSISTOR	
D513-517			DA204U	DIODE		Q506			DTA114YUA	DIGITAL TRANSISTOR	
D519			DA204U	DIODE		Q507			DTC114YUA	DIGITAL TRANSISTOR	

# TK-790/(B)/H(B)

## PARTS LIST

TX-RX UNIT (X57-5610-12) : TK-790H(B)

KCH-10

DISPLAY UNIT (X54-3190-20) : KCH-10

Ref. No.	Address	New parts	Parts No.	Description	Destination
Q509-513			DTC144EUA	DIGITAL TRANSISTOR	
Q514			DTA144TKA	DIGITAL TRANSISTOR	
Q516			DTA114TUA	DIGITAL TRANSISTOR	
Q517			DTC144EUA	DIGITAL TRANSISTOR	
Q518			DTA114EUA	DIGITAL TRANSISTOR	
Q519			2SJ506(S)	FET	
Q520			DTD114EK	DIGITAL TRANSISTOR	
Q522			2SC4215(Y)	TRANSISTOR	
Q523,524			DTC114TU	DIGITAL TRANSISTOR	
Q525			DTC144EUA	DIGITAL TRANSISTOR	
Q526			DTA114TUA	DIGITAL TRANSISTOR	
Q527			DTC144EUA	DIGITAL TRANSISTOR	
Q528			DTA114TUA	DIGITAL TRANSISTOR	
Q529,530			DTC144EUA	DIGITAL TRANSISTOR	
Q531			DTA114TUA	DIGITAL TRANSISTOR	
Q532-536			DTC144EUA	DIGITAL TRANSISTOR	
Q537-540			DTD114EK	DIGITAL TRANSISTOR	
Q541			DTC114EUA	DIGITAL TRANSISTOR	
Q542			DTA114EUA	DIGITAL TRANSISTOR	
Q543,544			DTC114EUA	DIGITAL TRANSISTOR	
TH101			157-503-53006	THERMISTOR	
TH501			157-302-53008	THERMISTOR	
A101			W02-1939-05	DBM	
<b>KCH-10</b>					
201	3E	*	A62-0606-13	PANEL ASSY	
203	1F		E37-0787-05	LEAD WIRE WITH CONNECTOR (SP)	
205	3F		G53-0838-03	PACKING (PANEL ASSY)	
206	1E		G53-0839-14	PACKING (SP)	
207	3E	*	G53-1523-04	PACKING (VOL)	
208	2N		H10-6622-02	POLYSTYRENE FOAMED FIXTURE	
209	1M		H11-0894-04	POLYSTYRENE FOAMED BOARD	
210	1N		H13-1059-04	CARTON BOARD	
211	1N		H25-0029-04	PROTECTION BAG (60/110/0.07)	
212	2M		H25-0103-04	PROTECTION BAG (125/250/0.07)	
213	2N		H25-0117-04	PROTECTION BAG (80/250/0.07)	
214	3M		H52-1271-02	ITEM CARTON CASE	
217	2E	*	J21-8417-04	HARDWARE FIXTURE (MIC CONNECTOR)	
216	2E		J39-0625-04	SPACER (TX-BUSY)	
218	3E		K29-4664-04	KNOB (VOL,UP/DOWN)	
219	2N		K29-4704-04	KNOB ACSY	
220	2E		K29-5251-12	KEY TOP	
221	2N		K29-5276-03	KNOB ACSY	
222	2N		K29-5277-03	KNOB ACSY	
223	2N		K29-5305-03	KNOB ACSY	
U	1E		N87-2605-46	BRAZIER HEAD TAPTITE SCREW	
V	1E,1F		N87-2608-46	BRAZIER HEAD TAPTITE SCREW	
W	2E,2F		N87-3006-46	BRAZIER HEAD TAPTITE SCREW	
225	1N		N99-0364-05	SCREW SET ACSY	
227	2F		T07-0265-05	SPEAKER	

Ref. No.	Address	New parts	Parts No.	Description	Destination
<b>DISPLAY UNIT (X54-3190-20) : KCH-10</b>					
-			B11-1148-14	ILLUMINATION GUIDE	
-			B11-1149-04	FILTER	
D6-11			B30-2140-05	LED (YEL)	
D12			B30-2194-05	LED (GREEN)	
D13			B30-2193-05	LED (RED)	
ED1			B38-0800-05	LCD	
C11			CC73GCH1H101J	CHIP C 100PF J	
C17			CC73GCH1H101J	CHIP C 100PF J	
C20			CK73GB1H102K	CHIP C 1000PF K	
C22			CK73GB1E103K	CHIP C 0.010UF K	
C23,24			CC73GCH1H101J	CHIP C 100PF J	
C25			CK73GB1E103K	CHIP C 0.010UF K	
C27			CK73GB1E223K	CHIP C 0.022UF K	
C28,29			CK73GB1E103K	CHIP C 0.010UF K	
C30			CC73GCH1H101J	CHIP C 100PF J	
C32			CC73GCH1H101J	CHIP C 100PF J	
C35-37			CK73GB1E103K	CHIP C 0.010UF K	
C43-47			CC73GCH1H101J	CHIP C 100PF J	
C48-50			CK73GB1H102K	CHIP C 1000PF K	
-		*	E29-1192-04	INTER CONNECTOR	
CN1			E40-5953-05	PIN ASSY	
CN2			E40-5704-05	PIN ASSY	
CN3			E40-5952-05	PIN ASSY	
CN4			E40-5738-05	PIN ASSY	
CN5			E40-5957-05	PIN ASSY SOCKET	
CN6			E40-5958-05	PIN ASSY	
J1		*	E56-0410-15	RF COAXIAL RECEPTACLE (MIC CONNECTOR)	
W1			E37-0703-05	LEAD WIRE WITH CONNECTOR	
X1			L78-0043-05	RESONATOR (4.19MHZ)	
R1,2			RK73GB1J102J	CHIP R 1.0K J 1/16W	
R5			RK73FB2A561J	CHIP R 560 J 1/10W	
R7			RK73FB2A331J	CHIP R 330 J 1/10W	
R8			R92-2023-05	CHIP R 820 J 1/2W	
R9			RK73FB2A181J	CHIP R 180 J 1/10W	
R10			R92-0670-05	CHIP R 0 OHM	
R11			RK73FB2A331J	CHIP R 330 J 1/10W	
R12			RK73FB2A181J	CHIP R 180 J 1/10W	
R13,14			RK73GB1J102J	CHIP R 1.0K J 1/16W	
R15			RK73FB2A151J	CHIP R 150 J 1/10W	
R16			RK73GB1J103J	CHIP R 10K J 1/16W	
R17			RK73GB1J331J	CHIP R 330 J 1/16W	
R18			R92-1281-05	FUSE R 4.7 J 1/4W	
R21			RK73GB1J473J	CHIP R 47K J 1/16W	
R23			RK73GB1J473J	CHIP R 47K J 1/16W	
R24			RK73GB1J101J	CHIP R 100 J 1/16W	
R26			RK73GB1J102J	CHIP R 1.0K J 1/16W	
R29-33			RK73GB1J102J	CHIP R 1.0K J 1/16W	
R34,35			RK73GB1J473J	CHIP R 47K J 1/16W	
R36			RK73GB1J102J	CHIP R 1.0K J 1/16W	
R38			R92-1252-05	CHIP R 0 OHM	
R39,40			RK73GB1J102J	CHIP R 1.0K J 1/16W	
R41-43			RK73GB1J473J	CHIP R 47K J 1/16W	
R45			R92-2063-05	CHIP R 680 J 1/2W	
R47			R92-2023-05	CHIP R 820 J 1/2W	
R48			RK73GB1J472J	CHIP R 4.7K J 1/16W	
R49-51			RK73GB1J473J	CHIP R 47K J 1/16W	

## PARTS LIST

DISPLAY UNIT (X54-3190-20) : KCH-10

KCH-11

DISPLAY UNIT (X54-3200-20) : KCH-11

Ref. No.	Address	New parts	Parts No.	Description	Destination
R52			RK73GB1J822J	CHIP R 8.2K J 1/16W	
R54			RK73GB1J103J	CHIP R 10K J 1/16W	
R55			RK73GB1J682J	CHIP R 6.8K J 1/16W	
R67			R92-1252-05	CHIP R 0 OHM	
VR1			R31-0607-05	VARIABLE RESISTOR (10K)	
S1			S40-1420-05	TACT SWITCH	
S2,3			S70-0410-15	TACT SWITCH	
S5-9			S70-0410-15	TACT SWITCH	
D1,2			DA204U	DIODE	
D5			02CZ9.1(X,Y)	ZENER DIODE	
D16,17			DA204U	DIODE	
D19-21			DA204U	DIODE	
D24			1SS301	DIODE	
D25			MA2S111	DIODE	
IC1			NJM78L05UA	IC (AVR)	
IC2			RH5VL42C	IC (RESET)	
IC3			AT24C64N10SI27	IC (EEPROM)	
IC4		*	78064GCA458EU	IC (CPU/LCD DRIVER)	
Q1			2SC2873(Y)	TRANSISTOR	
Q3-7			DTC144EU	DIGITAL TRANSISTOR	
Q9			DTC144EU	DIGITAL TRANSISTOR	
Q11			DTC144EU	DIGITAL TRANSISTOR	
Q12,13			DTC114TU	DIGITAL TRANSISTOR	
Q14,15			DTD114EK	DIGITAL TRANSISTOR	
S4			W02-0393-05	ENCODER	
<b>KCH-11</b>					
301	3G	*	A62-0607-13	PANEL ASSY	
303	3H		G53-0838-03	PACKING (PANEL ASSY)	
304	3G	*	G53-1523-04	PACKING (VOL)	
305	2P		H10-6622-02	POLYSTYRENE FOAMED FIXTURE	
306	10		H11-0894-04	POLYSTYRENE FOAMED BOARD	
307	1P		H13-1059-04	CARTON BOARD	
308	2P		H25-0029-04	PROTECTION BAG (60/110/0.07)	
309	20		H25-0103-04	PROTECTION BAG (125/250/0.07)	
310	2P		H25-0117-04	PROTECTION BAG (80/250/0.07)	
311	30		H52-1271-02	ITEM CARTON CASE	
312	1G	*	J21-8417-04	HARDWARE FIXTURE (MIC CONNECTOR)	
313	1G		J39-0625-04	SPACER (TX-BUSY)	
315	3G		K29-4664-04	KNOB (VOL,UP/DOWN)	
316	2P		K29-4704-04	KNOB ACSY	
317	2H		K29-5252-12	KEY TOP	
318	2P		K29-5276-03	KNOB ACSY	
319	2P		K29-5277-03	KNOB ACSY	
320	2P		K29-5305-03	KNOB ACSY	
X	1G		N87-2605-46	BRAZIER HEAD TAPTITE SCREW	
Y	1G,1H		N87-2608-46	BRAZIER HEAD TAPTITE SCREW	
Z	1G,2H		N87-3008-46	BRAZIER HEAD TAPTITE SCREW	
322	1P		N99-0364-05	SCREW SET ACSY	

Ref. No.	Address	New parts	Parts No.	Description	Destination
<b>DISPLAY UNIT (X54-3200-20) : KCH-11</b>					
D6			B30-2194-05	LED (GREEN)	
D7			B30-2193-05	LED (RED)	
ED1		*	B38-0801-15	LCD ASSY	
C9			CC73GCH1H101J	CHIP C 100PF J	
C14			CC73GCH1H101J	CHIP C 100PF J	
C20			CK73GB1H102K	CHIP C 1000PF K	
C22			CK73GB1E103K	CHIP C 0.010UF K	
C23,24			CC73GCH1H101J	CHIP C 100PF J	
C25			CK73GB1E103K	CHIP C 0.010UF K	
C27			CK73GB1E223K	CHIP C 0.022UF K	
C28,29			CK73GB1E103K	CHIP C 0.010UF K	
C30			CC73GCH1H101J	CHIP C 100PF J	
C32			CC73GCH1H101J	CHIP C 100PF J	
C35,36			CK73GB1E103K	CHIP C 0.010UF K	
C40			CK73GB1E103K	CHIP C 0.010UF K	
C50-60			CC73GCH1H101J	CHIP C 100PF J	
C61-67			CK73GB1H102K	CHIP C 1000PF K	
CN1			E40-5953-05	PIN ASSY	
CN2			E40-5704-05	PIN ASSY	
CN3			E40-5952-05	PIN ASSY	
CN4			E40-5738-05	PIN ASSY	
CN5			E40-5823-05	FLAT CABLE CONNECTOR	
J1		*	E56-0410-15	RF COAXIAL RECEPTACLE (MIC CONNECTOR)	
W1			E37-0703-05	LEAD WIRE WITH CONNECTOR	
X1			L78-0043-05	RESONATOR (4.19MHZ)	
R1,2			RK73GB1J102J	CHIP R 1.0K J 1/16W	
R5			RK73FB2A561J	CHIP R 560 J 1/10W	
R6			R92-2023-05	CHIP R 820 J 1/2W	
R7			R92-0670-05	CHIP R 0 OHM	
R8,9			RK73GB1J102J	CHIP R 1.0K J 1/16W	
R10			RK73FB2A151J	CHIP R 150 J 1/10W	
R11			RK73GB1J103J	CHIP R 10K J 1/16W	
R12			RK73GB1J331J	CHIP R 330 J 1/16W	
R13			R92-1281-05	FUSE R 4.7 J 1/4W	
R14			RK73GB1J473J	CHIP R 47K J 1/16W	
R16			RK73GB1J473J	CHIP R 47K J 1/16W	
R19,20			RK73GB1J473J	CHIP R 47K J 1/16W	
R21			RK73GB1J102J	CHIP R 1.0K J 1/16W	
R22			RK73GB1J101J	CHIP R 100 J 1/16W	
R24			RK73GB1J102J	CHIP R 1.0K J 1/16W	
R26			RK73GB1J472J	CHIP R 47K J 1/16W	
R28-32			RK73GB1J102J	CHIP R 1.0K J 1/16W	
R33,34			RK73GB1J473J	CHIP R 47K J 1/16W	
R35			RK73GB1J102J	CHIP R 1.0K J 1/16W	
R37,38			RK73GB1J102J	CHIP R 1.0K J 1/16W	
R39			RK73FB2A331J	CHIP R 330 J 1/10W	
R40,41			R92-2063-05	CHIP R 680 J 1/2W	
R42			RK73FB2A181J	CHIP R 180 J 1/10W	
R43			R92-2063-05	CHIP R 680 J 1/2W	
R44			R92-2023-05	CHIP R 820 J 1/2W	
R45-56			RK73GB1J473J	CHIP R 47K J 1/16W	
R57-62			RK73GB1J102J	CHIP R 1.0K J 1/16W	
R63			RK73GB1J473J	CHIP R 47K J 1/16W	
R65			RK73GB1J103J	CHIP R 10K J 1/16W	
R66			RK73GB1J682J	CHIP R 6.8K J 1/16W	
R67			R92-1252-05	CHIP R 0 OHM	

# TK-790/(B)/H(B)

## PARTS LIST

DISPLAY UNIT (X54-3200-20) : KCH-11

Ref. No.	Address	New parts	Parts No.	Description	Destination	Ref. No.	Address	New parts	Parts No.	Description	Destination
VR1			R31-0607-05	VARIABLE RESISTOR (10K)							
S1			S40-1420-05	TACT SWITCH							
S2,3			S70-0410-15	TACT SWITCH							
S5-15			S70-0410-15	TACT SWITCH							
D1,2			DA204U	DIODE							
D5			02CZ9.1(X,Y)	ZENER DIODE							
D11,12			DA204U	DIODE							
D14-16			DA204U	DIODE							
D18			1SS301	DIODE							
D19			MA2S111	DIODE							
IC1			NJM78L05UA	IC (AVR)							
IC2			RH5VL42C	IC (RESET)							
IC3			AT24C64N10SI27	IC (EEPROM)							
IC4		*	78064GCA458EU	IC (CPU)							
Q1			2SC2873(Y)	TRANSISTOR							
Q2-8			DTC144EU	DIGITAL TRANSISTOR							
Q9,10			DTC114TU	DIGITAL TRANSISTOR							
Q14,15			DTD114EK	DIGITAL TRANSISTOR							
S4			W02-0393-05	ENCODER							

# TK-790/(B)/H(B)

## EXPLODED VIEW (TK-790/(B))

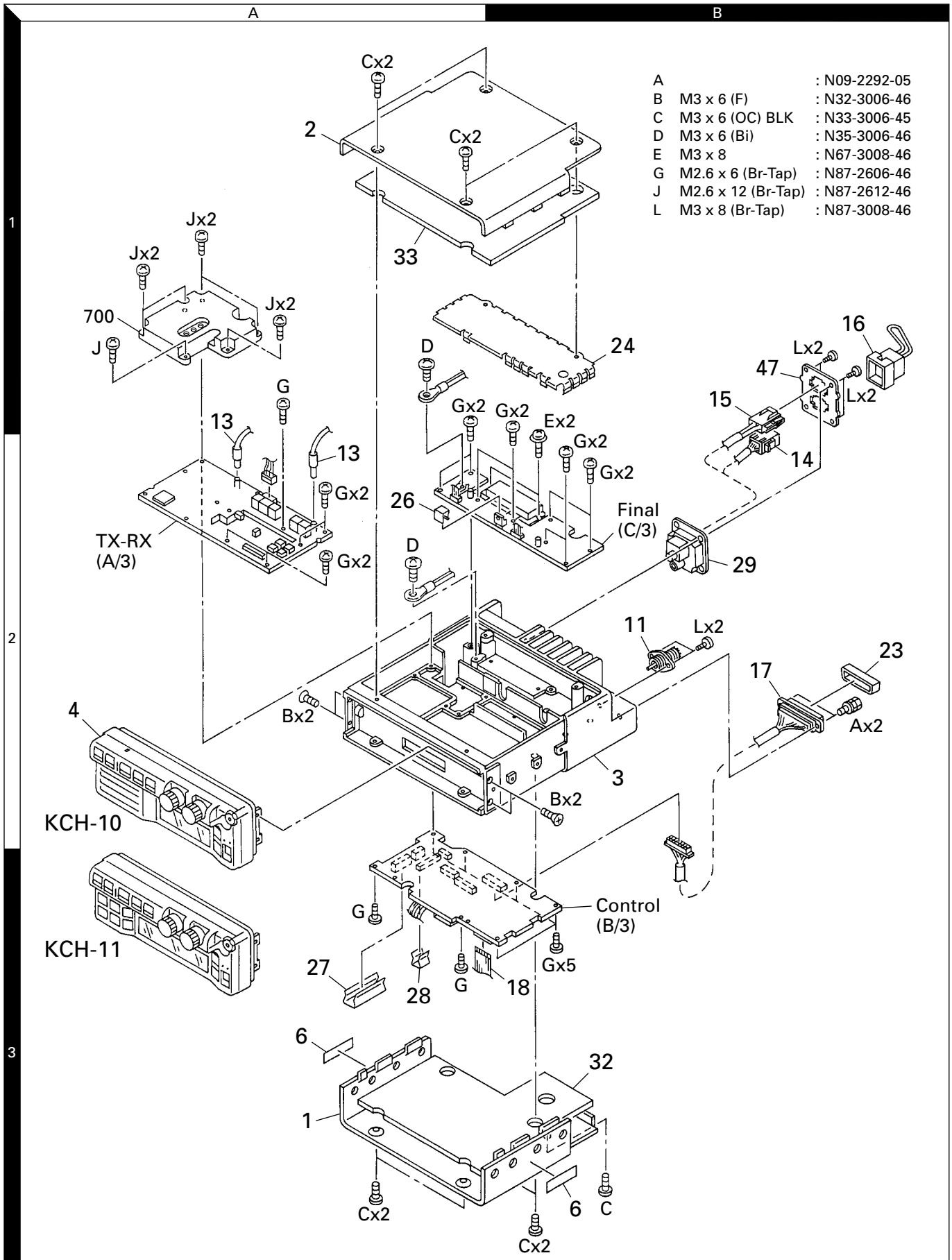

A	: N09-2292-05
B	M3 x 6 (F) : N32-3006-46
C	M3 x 6 (OC) BLK : N33-3006-45
D	M3 x 6 (Bi) : N35-3006-46
E	M3 x 8 : N67-3008-46
G	M2.6 x 6 (Br-Tap) : N87-2606-46
J	M2.6 x 12 (Br-Tap) : N87-2612-46
L	M3 x 8 (Br-Tap) : N87-3008-46

Parts with the exploded numbers larger than 700 are not supplied.

# TK-790/(B)/H(B)

## EXPLODED VIEW (TK-790H(B))

M	:	N09-2292-05
N	M3 x 6 (OC) BLK	: N33-3006-45
O	M3 x 6 (Bi)	: N35-3006-46
P	M3 x 8	: N67-3008-46
Q	M4 X 8	: N68-4006-46
R	M2.6 x 6 (Br-Tap)	: N87-2606-46
S	M2.6 x 12 (Br-Tap)	: N87-2612-46
T	M3 x 8 (Br-Tap)	: N87-3008-46

1

2

3

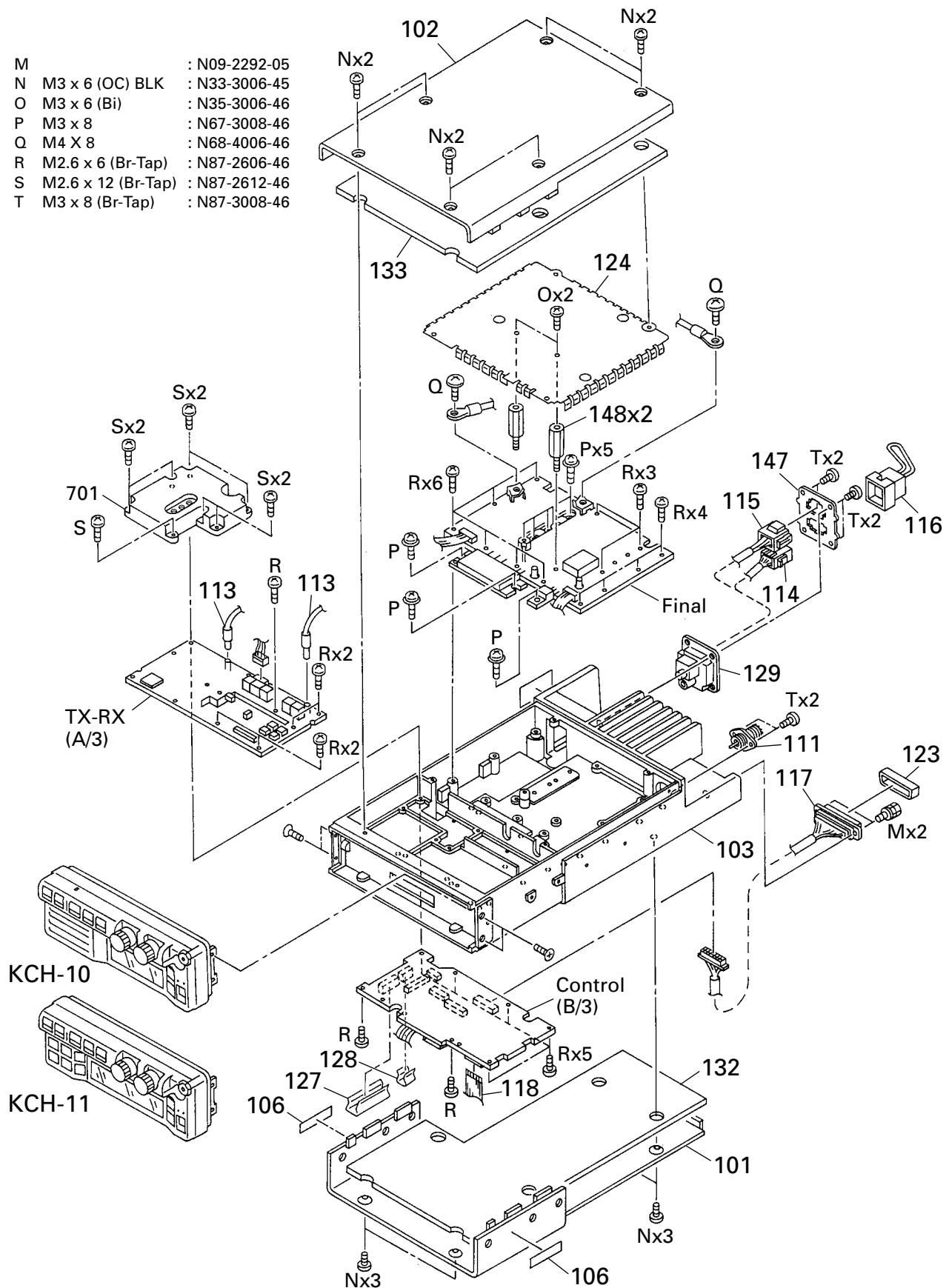

## EXPLODED VIEW (KCH-10)

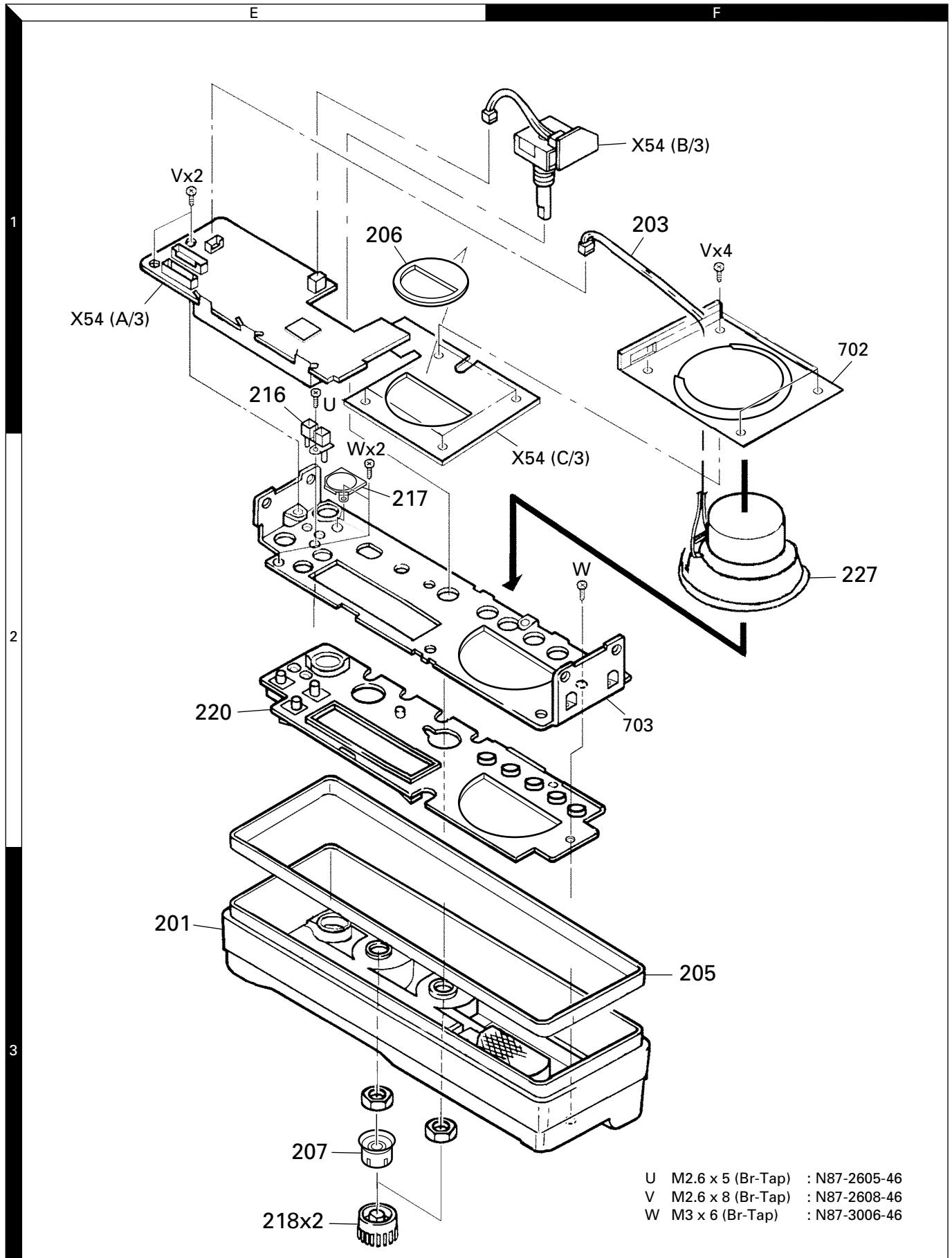

Parts with the exploded numbers larger than 700 are not supplied.

# TK-790/(B)/H(B)

## EXPLODED VIEW (KCH-11)

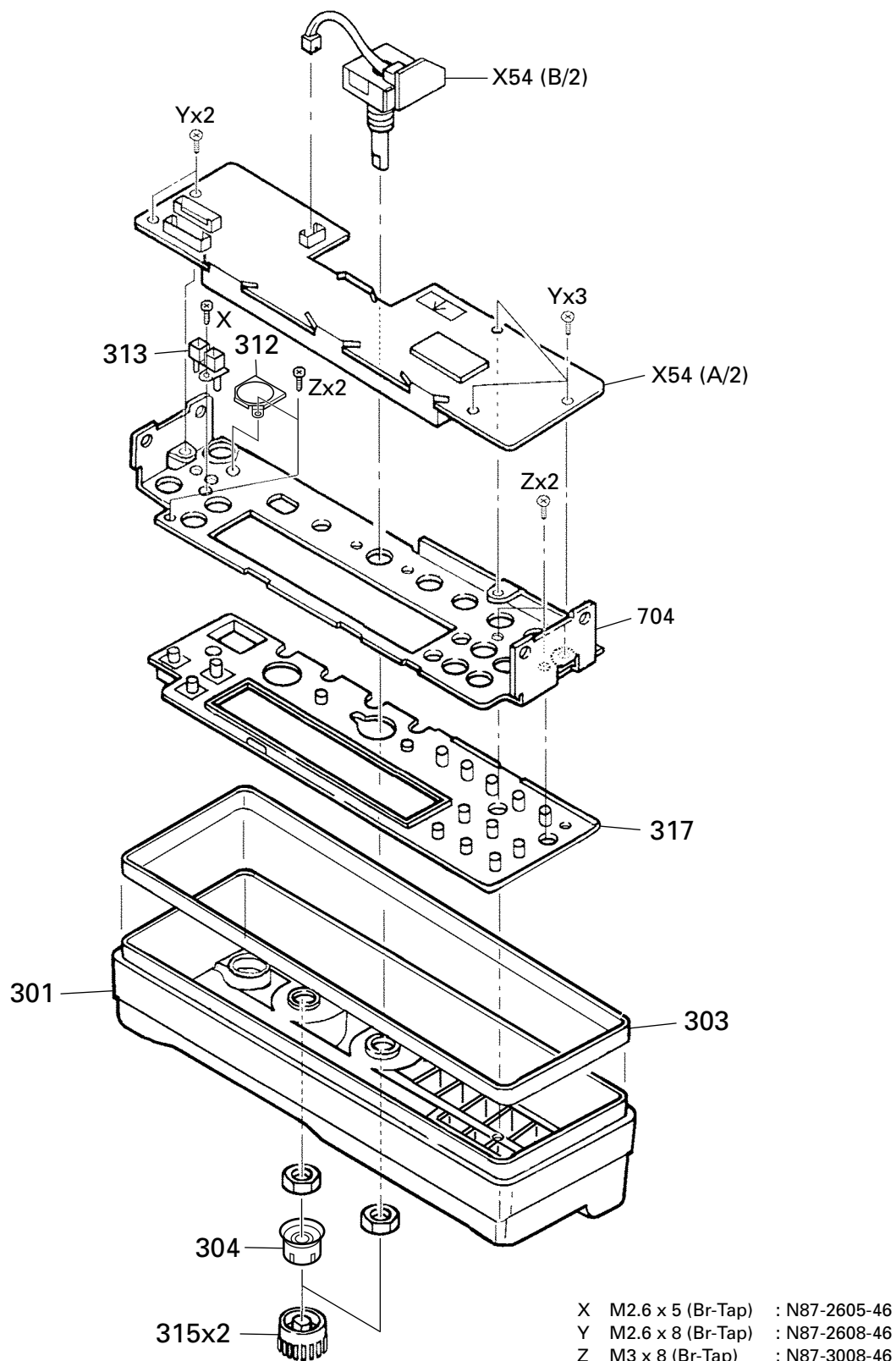

## PACKING (TK-790/(B))

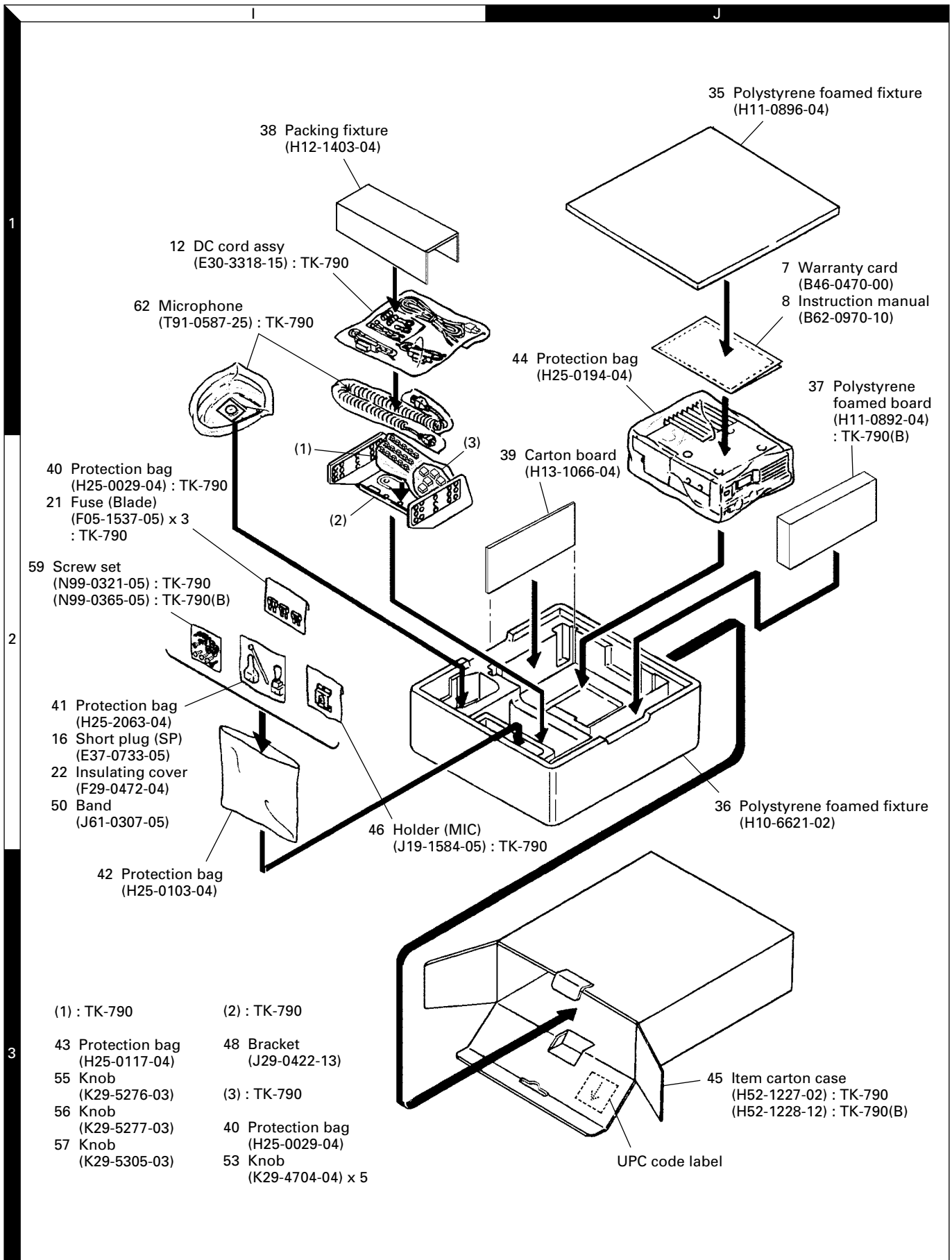

# TK-790/(B)/H(B)

## PACKING (TK-790H(B))

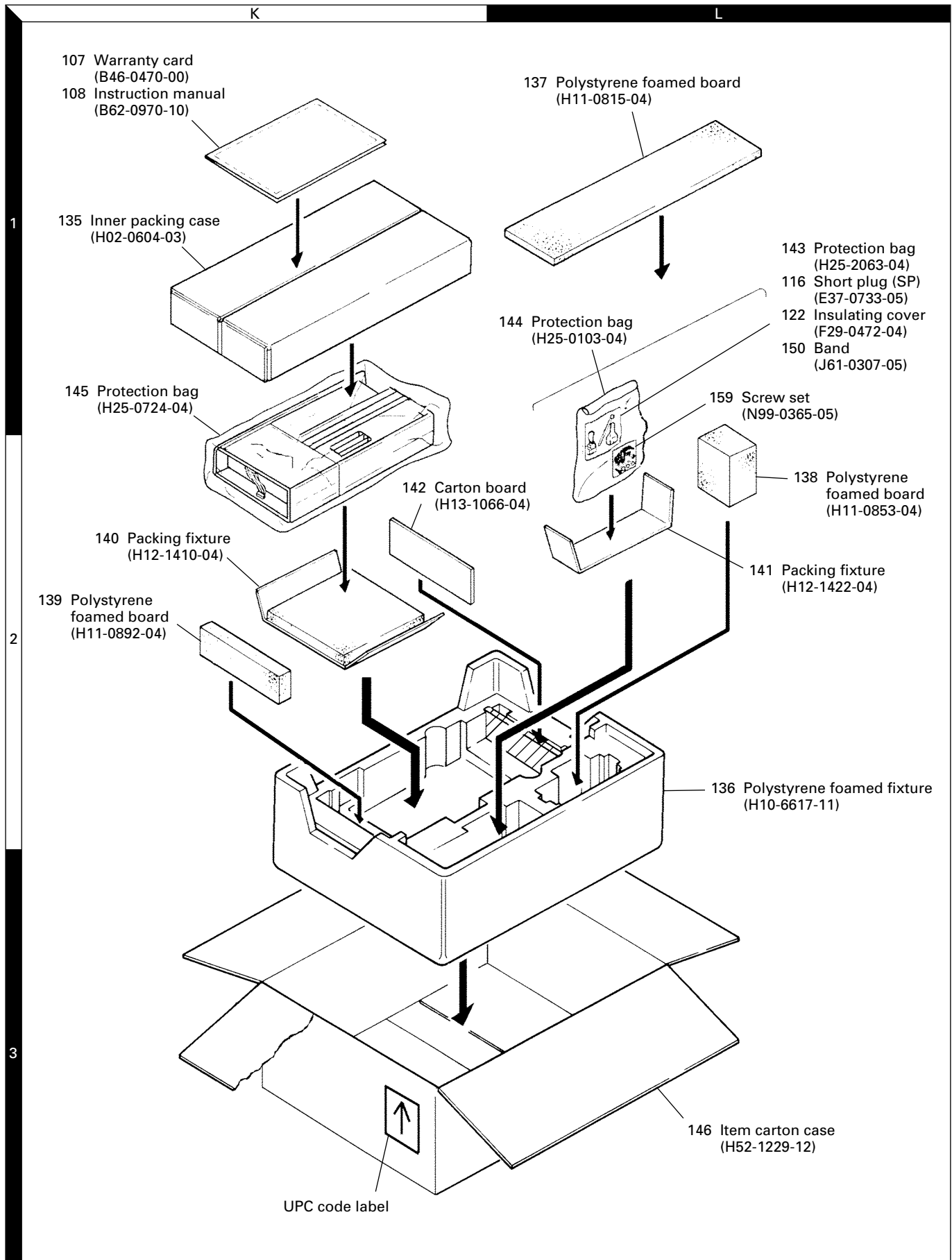

## PACKING (KCH-10)

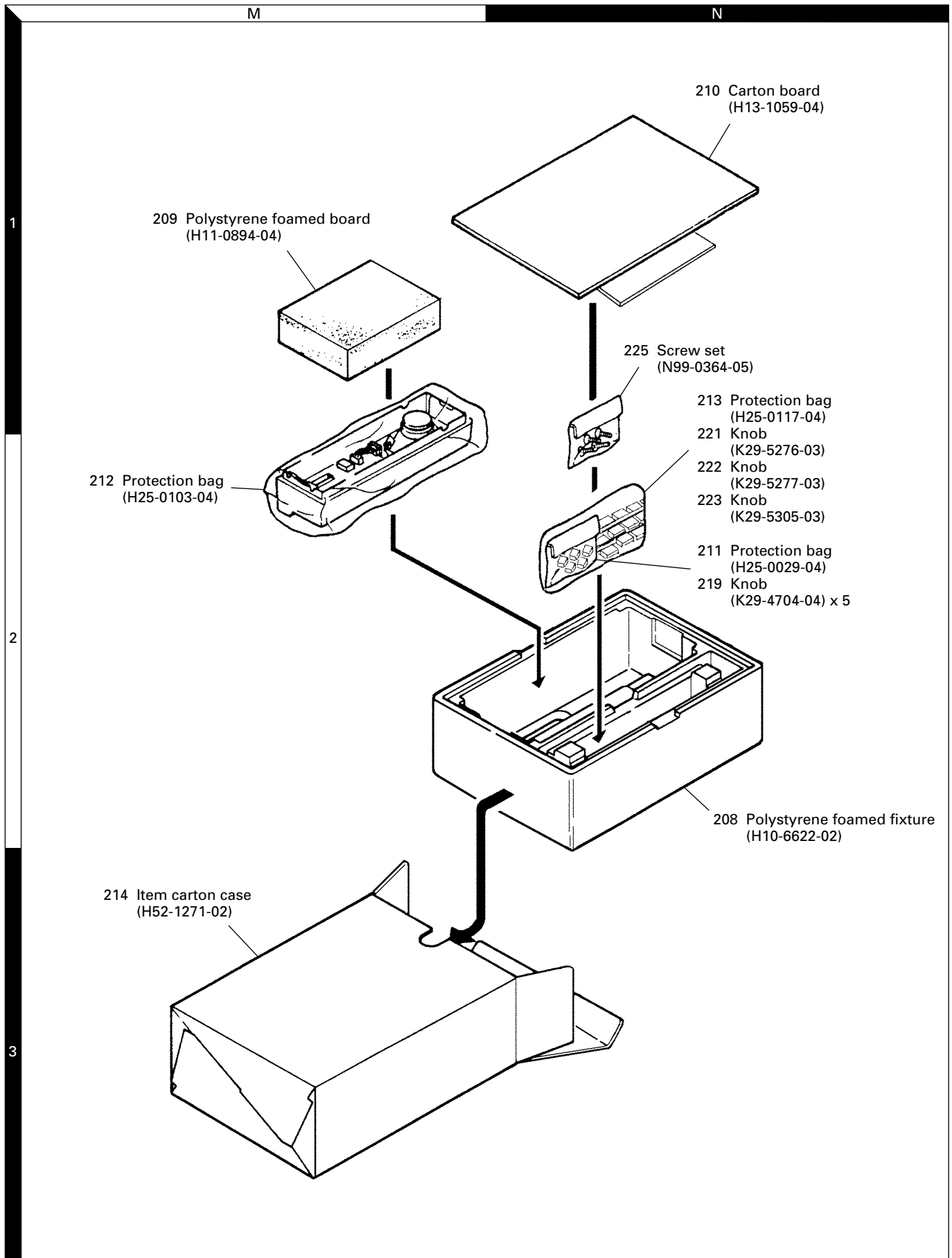

Parts with the exploded numbers larger than 700 are not supplied.

## PACKING (KCH-11)

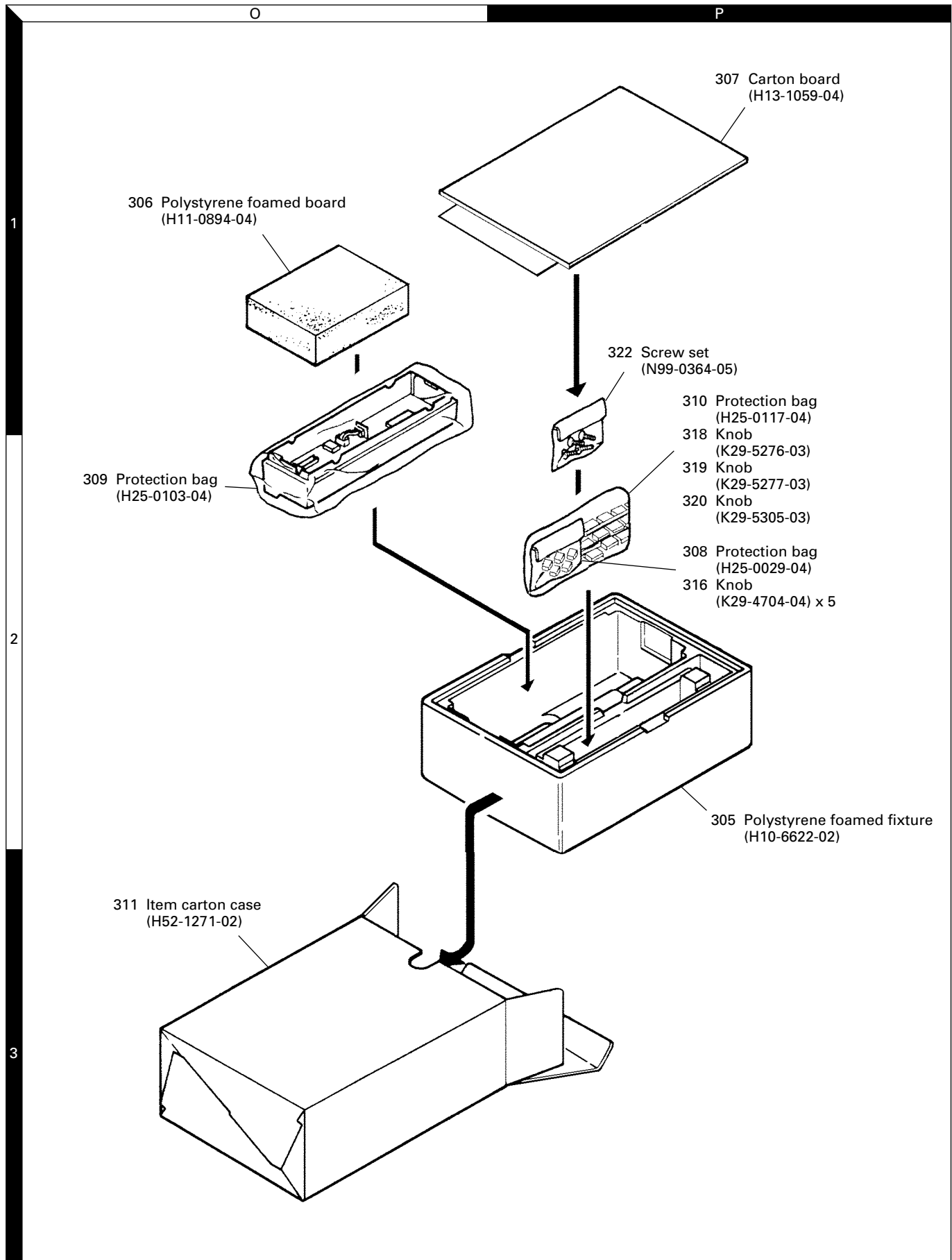

## ADJUSTMENT

### Key Functions in Panel Test Mode and Panel Tune Mode

Knob/Key	Test mode	Tune mode
GRP UP	Test mode/Tune mode changeover	
GRP DOWN	Monitor ON/OFF	
UP/DOWN	Narrow/Wide changeover	
PF1	Frequency CH down	Tuning item down
PF2	Frequency CH up	Tuning item up
PF3	Signalling CH down	Tuning value down
PF4	Signalling CH up	Tuning value up
PF5	Not used	Tuning value backup

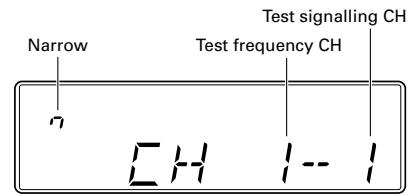

**Note :** When a key other than GRP down is pressed, the optional signalling is reset.

#### • Test frequency channel (MHz)

CH	K : TK-790/(B), 790H(B)		K2 : TK-790(B)	
	TX	RX	TX	RX
1	161.000	161.100	146.000	146.100
2	148.000	148.100	136.000	136.100
3	174.000	173.900	156.000	155.900
4	161.000	161.000	146.000	146.000
5	161.200	161.200	146.200	146.200
6	161.400	161.400	146.400	146.400
7	-	-	162.000	161.900

### Basic function panel

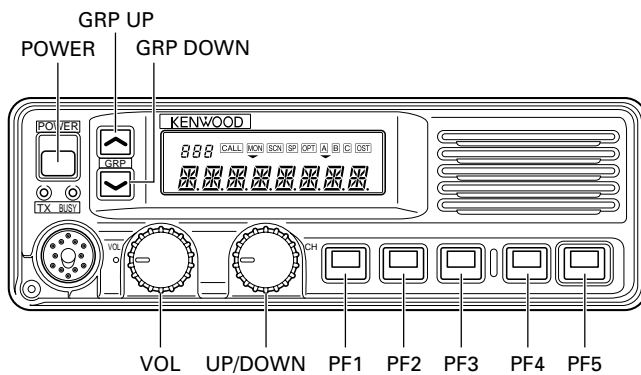

### Full function panel

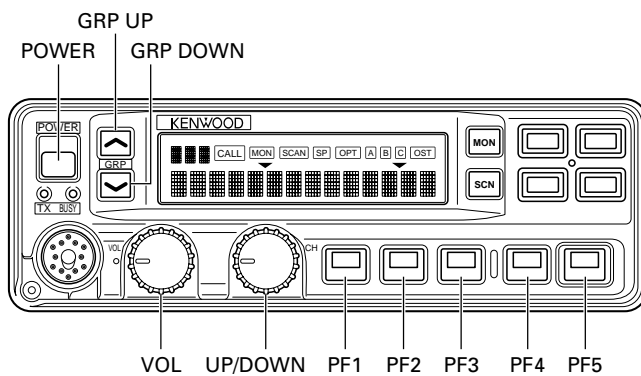

#### • Test signalling channel

CH No.	Encode tone	Decode tone
1	None	None
2	100Hz square wave	None
3	QT 67.0Hz	QT 67.0Hz
4	QT 151.4Hz	QT 151.4Hz
5	QT 250.3Hz	QT 250.3Hz
6	DQT 023N	DQT 023N
7	Single tone 1633Hz	2 tone 321.7/928.1Hz
8	DTMF [9]	DTMF [159]
9	MSK	None

### Panel Test Mode

The transceiver's transmission output, receive sensitivity, and other items are measured and QT, DQT, 2tone and DTMF signalling is decoded in this mode.

#### • To enter the panel test mode

Hold down [PF1] and turn the power switch on to enter this mode. The test frequency channel and test signalling channel will be displayed.

### Panel Tune Mode

The transceiver is adjusted in this mode.

#### • To enter the panel tune mode

Press the [GRP ^] key in the panel test mode.

In this mode, QT and DQT signalling is decoded, but 2tone and DTMF signalling is not decoded.

The adjustment items, the frequency and signalling, other than the maximum deviation and sensitivity, return to the values that were effective for the test frequency channel and test signalling channel before entering the panel tune mode.

## ADJUSTMENT

### • Tuning item and display (XXX : 0~255)

Tuning item	Basic display	Full display	Note
Frequency	FREQ_XXX	FREQUENCY_XXX_	
RF power	_POW_XXX	POWER_ _ _ _XXX_	
RF low power	LPOW_XXX	LOW_POWER_XXX_	
Max. deviation	MXDV_XXX	MAX_DEV_ _ _XXX_	Wide/Narrow item
Max. deviation (Low)	MXDV_XXX	MAX_DEV_ _ _XXX_	Three digits on the upper left side: " _ _ L" Transmission and reception at the low edge
Max. deviation (Center)	MXDV_XXX	MAX_DEV_ _ _XXX_	Three digits on the upper left side: " _ _ C" Transmission and reception at the center
Max. deviation (High)	MXDV_XXX	MAX_DEV_ _ _XXX_	Three digits on the upper left side: " _ _ H" Transmission and reception at the high edge
DQT balance	BLNC_XXX	DQT_BLNCE_XXX_	Wide/Narrow item
QT deviation	QTDV_XXX	QT_DEV_ _ _XXX_	Wide/Narrow item
DQT deviation	DQDV_XXX	DQT_DEV_ _ _XXX_	Wide/Narrow item
DTMF deviation	DTDV_XXX	DTMF_DEV_ _XXX_	Wide/Narrow item
MSK deviation	MSDV_XXX	MSK_DEV_ _ _XXX_	Wide/Narrow item
Sensitivity	SENS_XXX	RX_SENSE_ _XXX_	Wide/Narrow item
Sensitivity (Low)	SENS_XXX	RX_SENSE_ _XXX_	Three digits on the upper left side: " _ _ L" Transmission and reception at the low edge
Sensitivity (Center)	SENS_XXX	RX_SENSE_ _XXX_	Three digits on the upper left side: " _ _ C" Transmission and reception at the center
Sensitivity (High)	SENS_XXX	RX_SENSE_ _XXX_	Three digits on the upper left side: " _ _ H" Transmission and reception at the high edge
Squelch tight point	SQ_T_XXX	SQL_TIGHT_XXX_	Wide/Narrow item
Squelch open point	SQ_O_XXX	SQL_OPEN_ _XXX_	Wide/Narrow item

### Basic display

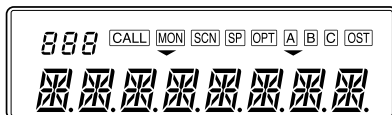

### Full display

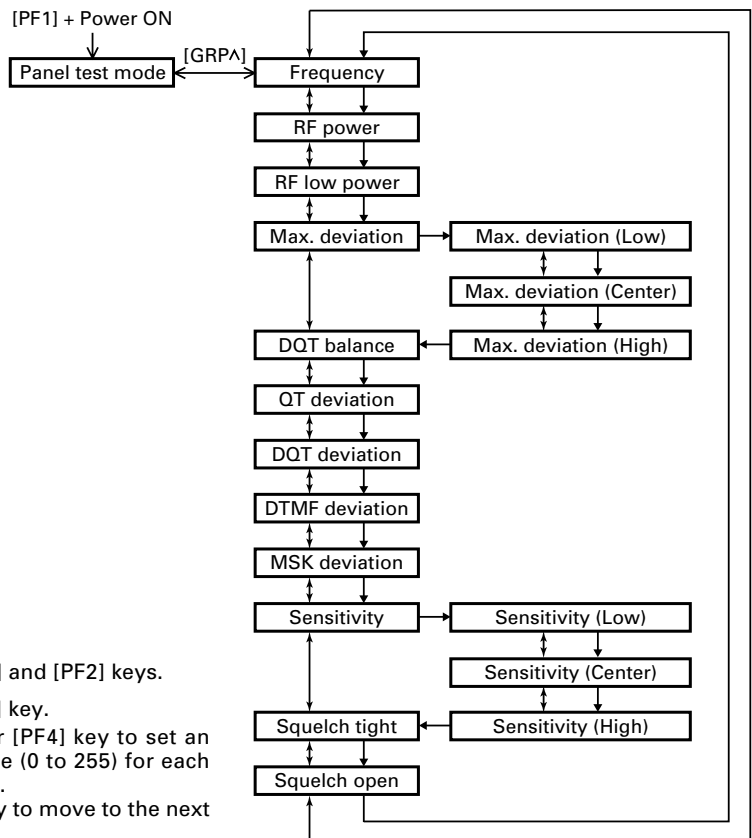
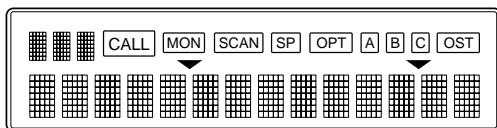

## ADJUSTMENT

### Test Equipment Required for Alignment

No.	Test Equipment	Major Specifications	
1	Standard Signal Generator (SSG)	Frequency Range Modulation Output	100 to 200MHz. Frequency modulation and external modulation. 0.1μV to greater than 1mV.
2	Power Meter	Input Impedance Operation Frequency Measurement Capability	50Ω. 100 to 200MHz or more. Vicinity of 200W.
3	Deviation Meter	Frequency Range	148 to 174MHz.
4	Digital Volt Meter (DVM)	Measuring Range Accuracy	1 to 20V DC. High input impedance for minimum circuit loading.
5	Oscilloscope		DC through 30MHz.
6	High sensitivity Frequency Counter	Frequency Range Frequency Stability	10Hz to 200MHz. 0.2ppm or less.
7	Ammeter		30A.
8	AF Volt Meter (AF VTVM)	Frequency Range Voltage Range	50Hz to 10kHz. 3mV to 3V.
9	Audio Generator (AG)	Frequency Range Output	50Hz to 5kHz or more. 0 to 1V.
10	Distortion Meter	Capability Input Level	3% or less at 1kHz. 50mV to 10Vrms.
11	Voltmeter	Measuring Range Input Impedance	10 to 1.5V DC or less. 50kΩ/V or greater.
12	4Ω Dummy Load		Approx. 4Ω 30W.
13	Regulated Power Supply		(Adjustable from 9 to 17V, 30A). Useful if ammeter equipped.

### Caution

Since the RX AF output is a BTL output, there is a DC Component. Isolate this with a capacitor or transformer as shown in the figure.

#### MIC connector (Front view)

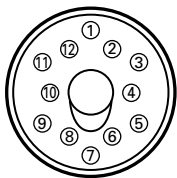

- 1 : SB
- 2 : HOOK
- 3 : MICG
- 4 : MIC
- 5 : Earth
- 6 : TRD
- 7 : NC
- 8 : DM
- 9 : BLC
- 10 : PTT
- 11 : NC
- 12 : NC

#### Test cable for microphone input

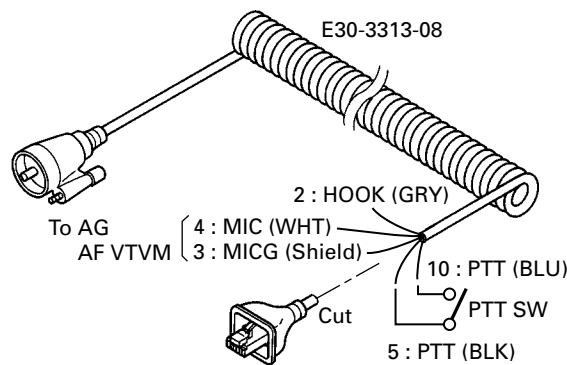

#### Test cable for speaker output

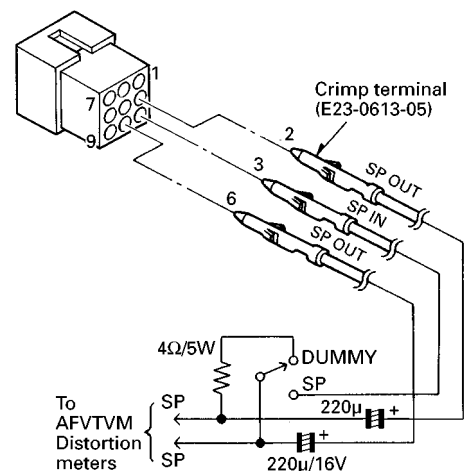

# TK-790/(B)/H(B)

## ADJUSTMENT

### Adjustment Points

#### • TK-790/(B)

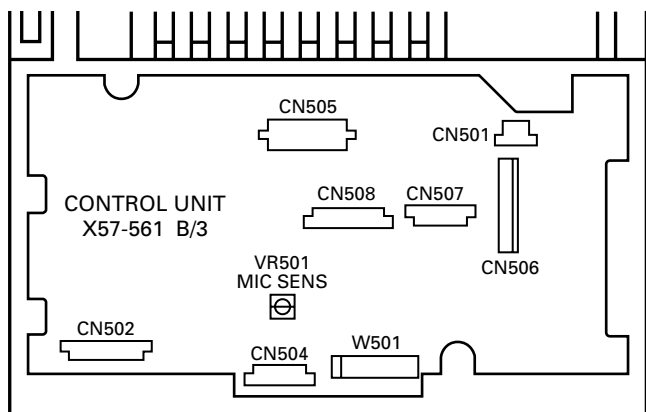
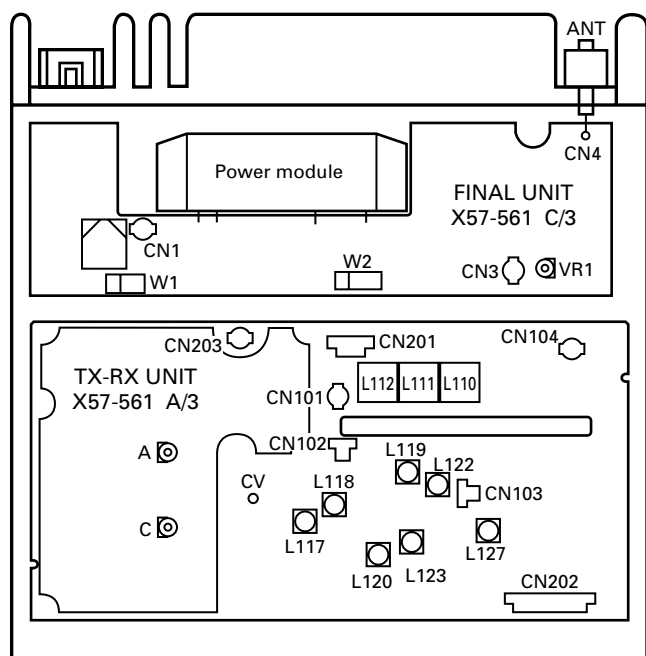

#### • TK-790H(B)

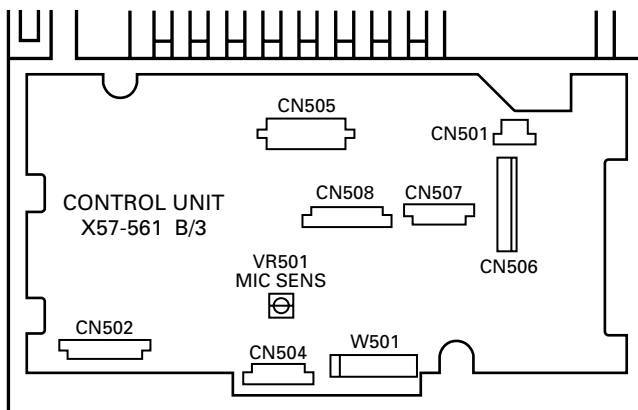
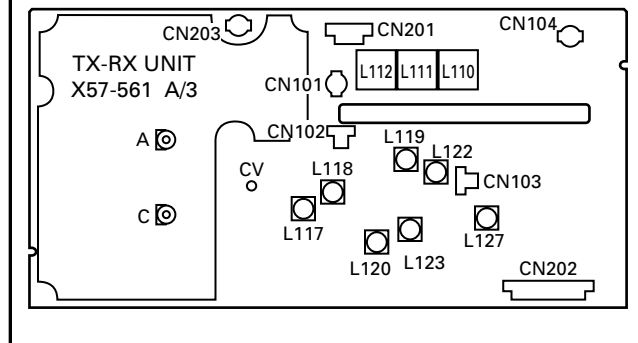
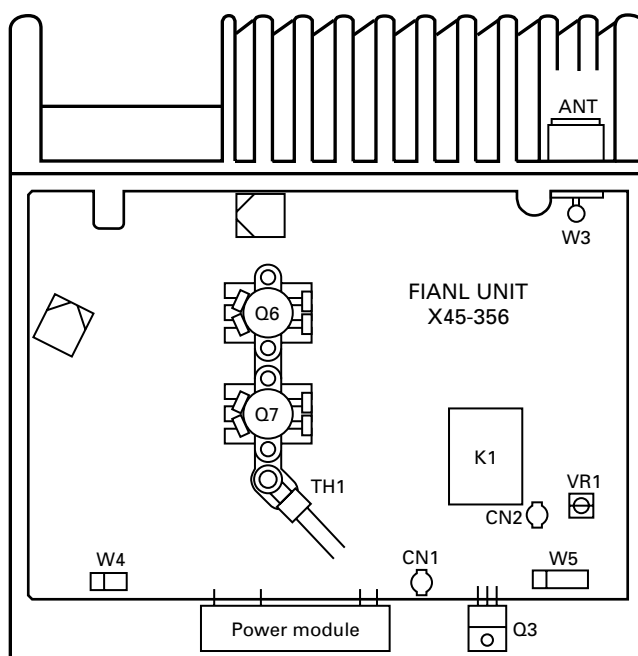

## ADJUSTMENT

### Common Section

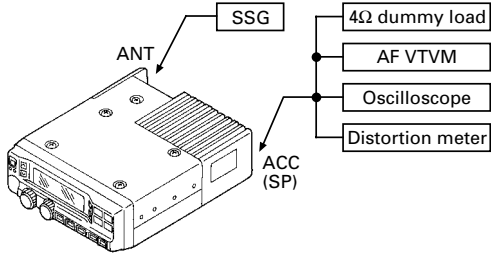
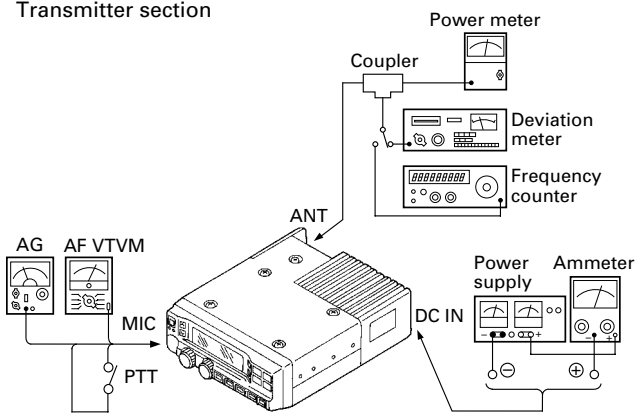
Item	Condition	Measurement			Adjustment			Specifications/Remarks																																																																								
		Test-equipment	Unit	Terminal	Unit	Parts	Method																																																																									
1. Frequency list	<ul style="list-style-type: none"> <li>Frequency range (MHz) K : 148~174 (TK-790/(B), 790H(B)) K2 : 136~156 (TK-790(B))</li> <li>Adjustment frequency (MHz)</li> </ul> <table border="1"> <thead> <tr> <th rowspan="2">CH</th> <th colspan="2">K</th> <th colspan="2">K2</th> </tr> <tr> <th>TX</th> <th>RX</th> <th>TX</th> <th>RX</th> </tr> </thead> <tbody> <tr><td>1</td><td>161.000</td><td>161.100</td><td>146.000</td><td>146.100</td></tr> <tr><td>2</td><td>148.000</td><td>148.100</td><td>136.000</td><td>136.100</td></tr> <tr><td>3</td><td>174.000</td><td>173.900</td><td>156.000</td><td>155.900</td></tr> <tr><td>4</td><td>161.000</td><td>161.000</td><td>146.000</td><td>146.000</td></tr> <tr><td>5</td><td>161.200</td><td>161.200</td><td>146.200</td><td>146.200</td></tr> <tr><td>6</td><td>161.400</td><td>161.400</td><td>146.400</td><td>146.400</td></tr> <tr><td>7</td><td>-</td><td>-</td><td>162.000</td><td>161.900</td></tr> </tbody> </table>	CH	K		K2		TX	RX	TX	RX	1	161.000	161.100	146.000	146.100	2	148.000	148.100	136.000	136.100	3	174.000	173.900	156.000	155.900	4	161.000	161.000	146.000	146.000	5	161.200	161.200	146.200	146.200	6	161.400	161.400	146.400	146.400	7	-	-	162.000	161.900				<ul style="list-style-type: none"> <li>Signalling</li> </ul> <table border="1"> <thead> <tr> <th>CH No.</th> <th>Encode tone</th> <th>Decode tone</th> </tr> </thead> <tbody> <tr><td>1</td><td>None</td><td>None</td></tr> <tr><td>2</td><td>100Hz square wave</td><td>None</td></tr> <tr><td>3</td><td>QT 67.0Hz</td><td>QT 67.0Hz</td></tr> <tr><td>4</td><td>QT 151.4Hz</td><td>QT 151.4Hz</td></tr> <tr><td>5</td><td>QT 250.3Hz</td><td>QT 250.3Hz</td></tr> <tr><td>6</td><td>DQT 023N</td><td>DQT 023N</td></tr> <tr><td>7</td><td>Single tone 1633Hz</td><td>2 tone 321.7/928.1Hz</td></tr> <tr><td>8</td><td>DTMF [9]</td><td>DTMF [159]</td></tr> <tr><td>9</td><td>MSK</td><td>None</td></tr> </tbody> </table>	CH No.	Encode tone	Decode tone	1	None	None	2	100Hz square wave	None	3	QT 67.0Hz	QT 67.0Hz	4	QT 151.4Hz	QT 151.4Hz	5	QT 250.3Hz	QT 250.3Hz	6	DQT 023N	DQT 023N	7	Single tone 1633Hz	2 tone 321.7/928.1Hz	8	DTMF [9]	DTMF [159]	9	MSK	None	
CH	K		K2																																																																													
	TX	RX	TX	RX																																																																												
1	161.000	161.100	146.000	146.100																																																																												
2	148.000	148.100	136.000	136.100																																																																												
3	174.000	173.900	156.000	155.900																																																																												
4	161.000	161.000	146.000	146.000																																																																												
5	161.200	161.200	146.200	146.200																																																																												
6	161.400	161.400	146.400	146.400																																																																												
7	-	-	162.000	161.900																																																																												
CH No.	Encode tone	Decode tone																																																																														
1	None	None																																																																														
2	100Hz square wave	None																																																																														
3	QT 67.0Hz	QT 67.0Hz																																																																														
4	QT 151.4Hz	QT 151.4Hz																																																																														
5	QT 250.3Hz	QT 250.3Hz																																																																														
6	DQT 023N	DQT 023N																																																																														
7	Single tone 1633Hz	2 tone 321.7/928.1Hz																																																																														
8	DTMF [9]	DTMF [159]																																																																														
9	MSK	None																																																																														
2. Setting	<ul style="list-style-type: none"> <li>Receiver section The indicated SSG output level are for maximum output. Whenever there is no modulation designation, standard modulation (MOD : 1kHz, DEV : 3kHz (Wide), DEV : 1.5kHz (Narrow)) is indicated.</li> </ul>  <p>Connect the front panel (KCH-10) to the transceiver's body.</p>			<ul style="list-style-type: none"> <li>Transmitter section</li> </ul> 																																																																												
3. PLL lock voltage	1) CH-SIG : 3-1 <b>K</b> CH-SIG : 7-1 <b>K2</b> 2) CH-SIG : 3-1 <b>K</b> CH-SIG : 7-1 <b>K2</b> PTT : ON 3) CH-SIG : 2-1 4) CH-SIG : 2-1 PTT : ON	DC VM Power meter	TX-RX (A/3)	CV	TX-RX (A/3)	A (TC301) C (TC302)	1.5V	±0.1V																																																																								
							Check	8.0V or less																																																																								
4. Transmit frequency	1) CH-SIG : 1-1 Select FREQ_XXX in tune mode PTT : ON	Power meter f. counter	Rear	ANT	Panel	PF3 key PF4 key	CH-1 frequency	±70Hz																																																																								

## ADJUSTMENT

Item	Condition	Measurement			Adjustment			Specifications/Remarks
		Test-equipment	Unit	Terminal	Unit	Parts	Method	
5. BPF	1) CH-SIG : 2-1 Spectrum analyzer Span : 50MHz Scale : 5dB div Tracking generator Output : -20dBm	Spectrum analyzer  Tracking generator	TX-RX (A/3)  Rear	CN101  ANT	TX-RX (A/3)	L112 L111 L110	Adjust the coils in the following order : L112, L111, L110	
6. MCF • Wide  • Narrow	1) CH-SIG : 1-1 Spectrum analyzer Span : 25kHz Scale : 2dB div Center frequency : 44.850MHz Tracking generator Output : -20dBm	Spectrum analyzer  Tracking generator	TX-RX (A/3)	CN103  CN102	TX-RX (A/3)	L118 L119 L122	Adjust it to make gain maximum, and make the band flat as shown in the below.	
	1) Up/down knob : Set the narrow "n_ _" appear on the LCD					L117 L120 L123		
7. Distortion	1) CH-SIG : 1-1 (Wide) SSG output : -53dBm/501μV AF output : 2V/4Ω	SSG Distortion meter AF VTVM Oscilloscope 4Ω dummy load	Rear	ANT EXT.SP			Check	3% or less If the distortion value exceeds 3%, you must adjust L127 to obtain a minimum distortion value.
8. RF power • High power model (High power)  (Low power)	1) CH-SIG : 1-1 Select _POW_XXX in tune mode PTT : ON	Power meter Ammeter	Rear	ANT	Final	VR1	Maximum clockwise	115W or more
							110W adj.	110W±5W, 25A or less
	1) CH-SIG : 1-1 Select LPOW_XXX in tune mode PTT : ON				Panel	PF3 key PF4 key	Check 45W adj.	110W ±5W 45W±1W

## ADJUSTMENT

Item	Condition	Measurement			Adjustment			Specifications/Remarks	
		Test-equipment	Unit	Terminal	Unit	Parts	Method		
<ul style="list-style-type: none"> <li>Med power model (High power)</li> <li>(Low power)</li> </ul>	1) CH-SIG : 1-1 Select _POW_XXX in tune mode PTT : ON	Power meter Ammeter	Rear	ANT	TX-RX (C/3)	VR1	Maximum clockwise	47W or less	
							45W adj.	45W±1W, 12A or less	
					Panel	PF3 key PF4 key	Check	45W±1W	
							5W adj.	5W±1W	
9. Maximum deviation <ul style="list-style-type: none"> <li>Wide</li> <li>Narrow</li> </ul>	1) Select __L MXDV_XXX in tune mode PTT : ON Deviation meter filter HPF : OFF LPF : 15kHz De-emphasis : OFF AG : 1kHz/50mV	Power meter Deviation meter AF VTVM AG Oscilloscope	Rear	ANT	Panel	PF3 key PF4 key	Wide ±4.1kHz	±0.1kHz	
	2) Select __C MXDV_XXX in tune mode PTT : ON		Panel						MIC
	3) Select __H MXDV_XXX in tune mode PTT : ON								
	1) Up/down knob : Set the narrow n_L MXDV_XXX in tune mode PTT : ON								
	2) Select n_C MXDV_XXX in tune mode PTT : ON								
	3) Select n_H MXDV_XXX in tune mode PTT : ON								
	10. MIC sensitivity Wide only		1) CH-SIG : 1-1 PTT : ON Deviation meter filter HPF : OFF LPF : 15kHz De-emphasis : OFF AG : 1kHz/5mV						

## ADJUSTMENT

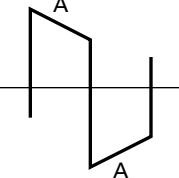
Item	Condition	Measurement			Adjustment			Specifications/Remarks
		Test-equipment	Unit	Terminal	Unit	Parts	Method	
11. DQT balance	1) CH-SIG : 1-2 Select BLNC_XXX in tune mode PTT : ON Deviation meter filter HPF : OFF LPF : 3kHz De-emphasis : OFF	Power meter Deviation meter AF VTVM AG Oscilloscope	Rear	ANT	Panel	PF3 key PF4 key	Wide/Narrow Make the demodulation waveform neat.	Flat the a parts. 
	Panel		MIC	2) Up/down knob : Set the narrow n__ BLNC_XXX in tune mode PTT : ON				
12. QT deviation	1) CH-SIG : 1-4 Select QTDV_XXX in tune mode PTT : ON Deviation meter filter HPF : OFF LPF : 3kHz De-emphasis : OFF						Wide $\pm 0.75\text{kHz}$	$\pm 0.05\text{kHz}$
	2) Up/down knob : Set the narrow n__ QTDV_XXX in tune mode PTT : ON						Narrow $\pm 0.35\text{kHz}$	$\pm 0.025\text{kHz}$
13. DQT deviation	1) CH-SIG : 1-6 Select DQDV_XXX in tune mode PTT : ON Deviation meter filter HPF : OFF LPF : 3kHz De-emphasis : OFF						Wide $\pm 0.75\text{kHz}$	$\pm 0.05\text{kHz}$
	2) Up/down knob : Set the narrow n__ DQDV_XXX in tune mode PTT : ON						Narrow $\pm 0.35\text{kHz}$	$\pm 0.025\text{kHz}$
14. DTMF deviation	1) CH-SIG : 1-8 Select DTDV_XXX in tune mode PTT : ON Deviation meter filter HPF : OFF LPF : 15kHz De-emphasis : OFF						Wide $\pm 3.0\text{kHz}$	$\pm 0.1\text{kHz}$
	2) Up/down knob : Set the narrow n__ DTDV_XXX in tune mode PTT : ON						Narrow $\pm 1.5\text{kHz}$	$\pm 0.05\text{kHz}$

## ADJUSTMENT

Item	Condition	Measurement			Adjustment			Specifications/Remarks
		Test-equipment	Unit	Terminal	Unit	Parts	Method	
15. MSK deviation	1) CH-SIG : 1-9 Select MSDV_XXX in tune mode PTT : ON Deviation meter filter HPF : OFF LPF : 15kHz De-emphasis : OFF	Power meter Deviation meter AF VTVM AG Oscilloscope	Rear	ANT	Panel	PF3 key PF4 key	Wide $\pm 3.0$ kHz	$\pm 0.1$ kHz
	Panel		MIC	Narrow $\pm 1.5$ kHz			$\pm 0.05$ kHz	
16. Sensitivity	1) CH-SIG : 2-1 Select __L SENS_XXX in tune mode SSG output : $-116$ dBm/ $0.35$ $\mu$ V AF output : $2$ V/ $4$ $\Omega$	SSG  AF VTVM Distortion meter Oscilloscope $4$ $\Omega$ dummy load	Rear	ANT			Wide low check	SINAD 12dB or more
	2) CH-SIG : 1-1 Select __C SENS_XXX in tune mode		EXT.SP	Wide center check				
	3) CH-SIG : 3-1 Select __H SENS_XXX in tune mode		Wide high check					
	4) CH-SIG : 1-1 Up/down knob : Set the narrow n_C SENS_XXX in tune mode		Narrow center check					
17. Squelch tight point	1) CH-SIG : 1-1 Select SQ_T_XXX in tune mode SSG output : Value when 6dB is added from the sensitivity value of 12dB SINAD.					Adjust to point of opening squelch	Set the value to 255. Adjust the SSG output to "Condition". Then, decrease the value to the point of opening the squelch.	
	2) Up/down knob : Set the narrow n__ SQ_T_XXX in tune mode							
18. Squelch open point	1) CH-SIG : 1-1 Select SQ_O_XXX in tune mode SSG output : Value when 3dB is subtracted from the sensitivity value of 12dB SINAD.							
	2) Up/down knob : Set the narrow n__ SQ_O_XXX in tune mode							
	3) SSG output : OFF					Wide/Narrow check	Squelch must be closed.	

## TERMINAL FUNCTION

Connector No.	Terminal No.	Terminal Name	I/O	Terminal Function
<b>FINAL UNIT (X45-3560-10) : TK-790H(B)</b>				
CN1 To TX-RX unit	1	DO	I	Transmission drive input. Coaxial connector.
CN2 To TX-RX unit	1	RA	O	Receiver signal output. Coaxial connector.
CN3	1	+B	I	Power supply input (13.4V±15%).
CN4	1	E	-	Earth.
W4 To Control unit	1 2 3	E +B +B	- O O	Earth. Power supply output (13.4V±15%). Power supply output (13.4V±15%).
W5 To TX-RX unit	1 2 3 4 5	DB E 8R 8T PC	O - I I I	Transmission drive control voltage output (APC). Earth. 8V input during reception. 8V input during transmission. TX power control signal input.
<b>TX-RX UNIT (X57-5610-XX) (A/3)</b>				
CN104 To Final unit	1	RA	I	Receiver signal input. Coaxial connector.
CN201 To Final unit	1 2 3 4 5	PC 8T 8R E DB	O O O - I	TX power control signal output. 8V output during transmissioin. 8V output during reception. Earth. Transmission drive control voltage input (APC).
CN202 To Control unit	1 2 3 4 5 6 7 8 9 10 11 12 13 14 15 16 17 18	NC UL EP CP MO MB SB DT ES CK KEY 8C E DET SQL RSI TV PC	- O I I I I I I I I I I - O O O I I I I	Not used. Lock detect output for PLL. "H" : Lock, "L" : Unlock ENABLE input for PLL. CLOCK input for PLL. Modulation signal input for VCO. Modulation and frequency control signal input for VCXO. Power output after power switch (13.6V or 13.4V±15%). DATA input. ENABLE input for shift register. CLOCK input for shift register. KEY signal input. "H" : TX Common 8V (8V±5%). Earth. Detection signal output. Squelch signal output. RSSI signal output. Tuning voltage signal input for RX BPF. TX power control signal input.
CN203 To Final unit	1	DO	O	Transmission drive output. Coaxial connector.

Connector No.	Terminal No.	Terminal Name	I/O	Terminal Function
<b>CONTROL UNIT (X57-5610-XX) (B/3)</b>				
W501 To Display unit	1 2 3 4 5 6 7 8 9 10 11	RS2 RS1 SB IGN PS TRD 1/2 RST E MIC ME	O O O I I I/O O O - I -	Output for remote speaker. Output for remote speaker. Power output after power switch (13.6V or 13.4V±15%). Ignition input. Power swith control signal input. TX data output/RX data input. Remote head 1 signal output. RESET signal output. Earth. MIC signal input. MIC earth.
CN501 To Final unit	1 2 3	+B +B E	I I -	Power supply input (13.6V or 13.4V±15%). Power supply input (13.6V or 13.4V±15%). Earth.
CN502 To TX-RX unit	1 2 3 4 5 6 7 8 9 10 11 12 13 14 15 16 17 18	PC TV RSI SQL DET E 8C KEY CK ES DT SB MB MO CP EP UL NC	O O I I I - O O O O O O O O O O I -	TX power control signal output. Tuning voltage signal output for RX BPF. RSSI signal input. Squelch signal input. Detection signal input. Earth Common 8V (8V±5%). KEY signal output. "H" : TX CLOCK output for shift register. ENABLE output for shift register. DATA output. Power output after power switch (13.6V or 13.4V±15%). Modulation and frequency control signal output for VCXO. Modulation signal output for VCO. CLOCK output for PLL. ENABLE output for PLL. Lock detect input for PLL. "H" : Lock, "L" : Unlock. Not used.
CN504 To Control cable (Remote kit)	1 2 3 4 5 6 7 8 9 10	AFO DE3 E EI CK DT RST 5C PSC CS	O I/O - O O O I/O O I/O O	RX audio signal output for head 2. Detection signal input from Radio 2. Earth ENABLE output for shift register. CLOCK output for shift register. DATA output for shift register. RESET signal output for Radio 2. Common 5V (5V±5%). Power switch control signal input/output. Chip select output for D/A converter.
CN505 To Acc 25 pin D-sub connector	1 2 3 4 5 6 7 8 9 10 11 12 13	RSI NC (SB) AI1 RSV1 AI2 RSV2 AI3 AFO AI4 E AI5 DEO E	O O I O I I I O I - I O -	RSSI signal output. Non connection. Auxiliary input 1 (FPU selectable). Reserved Auxiliary input 2 (FPU selectable). Reserved. Auxiliary input 3 (FPU selectable). RX audio signal output. Auxiliary input 4 (FPU selectable). Earth. Auxiliary input 5 (FPU selectable). Detector signal output. Earth.

# TERMINAL FUNCTION

Connector No.	Terminal No.	Terminal Name	I/O	Terminal Function	Connector No.	Terminal No.	Terminal Name	I/O	Terminal Function
	14	AO1	O	Auxiliary output 1 (FPU selectable).	CN3	1	RA	O	Receiver signal output.
	15	AO2	O	Auxiliary output 2 (FPU selectable).	To				Coaxial connector.
	16	AO3	O	Auxiliary output 3 (FPU selectable).	TX-RX				
	17	TXD2	O	Serial data output.	unit				
	18	AO4	O	Auxiliary output 4 (FPU selectable).	W1	1	E	-	Earth.
	19	RXD2	I	Serial data input.	To	2	+B	O	Power supply output (13.6V±15%).
	20	SQ	O	Squelch signal output. "H" : Busy, "L" : Not busy	Control	3	+B	O	Power supply output (13.6V±15%).
	21	TXS	O	TX sense signal output. "H" : TX, "L" : Another	unit				
	22	SPM	I	Speaker mute signal input. "H" : Mute on	W2	1	DB	O	Transmission drive control voltage output (APC).
	23	MCM	I	MIC mute signal input. "H" : Mute on	To	2	E	-	Earth
	24	ME	-	MIC earth.	TX-RX	3	8T	I	8V input during transmission.
	25	MI/DI	I	Mic/Data signal input 1. (Default : DI)	unit	4	PC	I	TX power control signal input.
	26~30	-	-	Non connection.	<b>DISPLAY UNIT (X54-3190-20) : KCH-10 (X54-3200-20) : KCH-11</b>				
CN506	1	IGN	I	Ignition sense input.	CN1	1	ME	-	MIC earth.
To Acc	2	E	-	Earth.	To	2	MIC	O	MIC signal output.
9 pin	3	HR1	O	Horn alert signal output 1.	Control	3	E	-	Earth.
connector	4	HR2	O	Horn alert signal output 2.	unit	4	RST	I	RESET signal input.
	5	OS1	O	BTL output for external speaker B (PA).		5	1/2	I	Remote head 1/2 signal input. "L" : Head 1, "H" : Head 2
	6	OS2	O	BTL output for external speaker B (PA).		6	TRD	I/O	TX data output/RX data input.
	7	ES2	O	BTL output for external speaker A.		7	PS	O	Power switch control signal output.
	8	ES1	O	BTL output for external speaker A.		8	IGN	O	Ignition sense output.
	9	RS1	I	Remote speaker switch.		9	SB	I	Power input after power switch (13.6V or 13.4V±15%).
CN507	1	SQ	O	Squelch signal output. "H" : Busy, "L" : No signal		10	RS1	I	Remote speaker input.
To	2	EMG	O	Emergency signal output.		11	RS2	I	Remote speaker input.
ANI	3	EPT	I	External PTT signal input.	CN2	1	RS1	O	Remote speaker output.
board	4	IO	I/O	Auxiliary input/output.	To	2	RS2	O	Remote speaker output.
	5	SEL	-	Non connection.	Remote				
	6	AS2	I	Audio mute input. "HiZ" : No change, "L" : Mute	speaker				
	7	MCM	I	MIC mute input. "HiZ" : No change, "L" : Mute	CN3	1	IGN	I	Ignition sense input.
	8	TON	I	Sidetone input.	To Acc	2	SB	O	Power output after power switch (13.6V or 13.4V±15%).
	9	TCN	I	Speaker mute input. "HiZ" : No change, "L" : Unmute	connector	3	E	-	Earth.
	10	DTI	I	Data input.		4	MIC	I	MIC signal input.
CN508	1	MCI	I	MIC signal input.		5	ME	-	MIC earth.
To	2	MCO	O	MIC signal output.		6	AI1	I	Auxiliary input 1 (FPU selectable).
voice	3	DEI	I	Detection signal input.		7	AI2	I	Auxiliary input 2 (FPU selectable).
scrambler	4	AC	O	Audio control signal output. "H" : OPT SW off, "L" : On		8	AO1	O	Auxiliary output 1 (FPU selectable).
	5	BC1	O	Scramble code output.		9	AO2	O	Auxiliary output 2 (FPU selectable).
	6	BC2	O	Scramble code output.	J1	1	SB	O	Power output after power switch (13.6V or 13.4V±15%)
	7	BC3	O	Scramble code output.	(MIC	2	HK	I	Hook signal input. "L" : On hook, "H" : Off hook
	8	BC4	O	Scramble code output.	jack)	3	ME	-	MIC earth.
	9	TXD2	O	TX data output 2.		4	MIC	I	MIC signal input.
	10	RXD2	I	RX data input 2.		5	E	-	Earth.
	11	DEO	O	Detection signal output.		6	TRD	I/O	TX data output/RX data input.
	12	PTO	O	PTT signal output.		7	NC	-	Not used.
	13	8C	O	Common 8V output.		8	DM	I/O	Serial data input/output for keypad MIC.
	14	E	-	Earth.		9	BLC	O	MIC backlight control signal output. "H" : On, "L" : Off
<b>FINAL UNIT (X57-5610-XX) (C/3) : TK-790/(B)</b>						10	PTT	I	PTT signal input. "L" : TX, "OPEN" : RX
CN1	1	DO	I	Transmission drive input.		11	NC	-	Not used.
To				Coaxial connector.		12	NC	-	Not used.
TX-RX									
unit									
CN2	1	+B	I	Power supply input (13.6V±15%).					

## TERMINAL FUNCTION

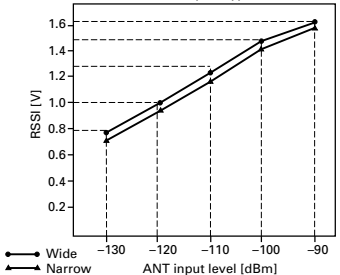
Connector No.	Terminal No.	Terminal Name	I/O	Terminal Function
<b>Acc 25 pin D-sub connector</b>				
	1	RSSI	O	RSSI signal output. 
	2	AI1	I	Auxiliary input 1 (FPU selectable).
	3	AI2	I	Auxiliary input 2 (FPU selectable).
	4	AI3	I	Auxiliary input 3 (FPU selectable).
	5	AI4	I	Auxiliary input 4 (FPU selectable).
	6	AI5	I	Auxiliary input 5 (FPU selectable).
	7	E	-	Earth
	8	AO2	O	Auxiliary output 1 (FPU selectable).
	9	TXD2	O	Serial data output.
	10	RXD2	I	Serial data input.
	11	TXS	O	TX sense signal output. "H" : TX, "L" : Another
	12	MCM	I	MIC mute signal input. "L" : Mute on, "H" : No change
	13	MI/DI	I	MIC/Data signal input 1. (Default : DI) Input impedance DI : 10kΩ or more MI : 600Ω Coupling DI : DC coupling MI : DC coupling Frequency response DI : ~9.6kHz +1/-3dB (1kHz=0dB) MI : Compliance with TIA/EIA-603 Deviation DI : 60% deviation or more. (1kHz 2.5Vp-p input) MI : 60% deviation (1kHz 5mV±1.5mV input)
	14	NC (SB)	O	Non connection. (SB : 13.6V or 13.4V 0.5A max. Refer to page 20)
	15	RSV1	-	Reserved.
	16	RSV2	-	Reserved.
	17	AFO	O	RX audio signal output (Same as CN504 pin No.1) RX condition : RX audio output. Output level 125mVrms. (Standard modulation) PA condition : MIC output. Output level 300mVrms. (1kHz 5mV input)
	18	E	-	Earth
	19	DEO	O	Detector signal output. Output impedance 1kΩ or less Coupling DC coupling Output level : 100mVrms (Standard modulation)

Connector No.	Terminal No.	Terminal Name	I/O	Terminal Function
				Output frequency response : Wide : 300~4.8kHz +1/-2dB 4.8~9.6kHz +1/-24dB Narrow : 300~4.8kHz +1/-10dB (1kHz=0dB)
	20	AO1	O	Auxiliary output 1 (FPU selectable).
	21	AO3	O	Auxiliary output 3 (FPU selectable).
	22	AO4	O	Auxiliary output 4 (FPU selectable).
	23	SQ	O	Squelch signal output. "L" : Busy, "H" : Not busy
	24	SPM	I	Speaker mute signal input. "L" : Mute on
	25	ME	-	MIC earth.

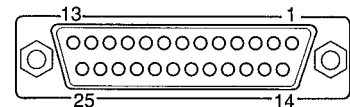

### Acc 9 pin connector

	1	IGN	I	Ignition sense input.
	2	ES2	O	BTL output for external speaker A.
	3	RS1	I	Remote speaker switch
	4	HR1	O	Horn alert signal output 1.
	5	HR2	O	Horn alert signal output 2.
	6	ES1	O	BTL output for external speaker A.
	7	OS1	O	BTL output for external speaker B (PA).
	8	OS2	O	BTL output for external speaker B (PA).
	9	E	-	Earth.

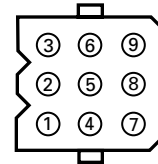

### Acc 12 pin connector (Remote kit)

	1	IGN	I	Ignition sense input.
	2	SB	O	Power output after power switch (13.6V or 13.4V±15%).
	3	E	-	Earth.
	4	MIC	I	MIC signal input.
	5	ME	-	MIC earth.
	6	AI1	I	Auxiliary input 1 (FPU selectable).
	7	AI2	I	Auxiliary input 2 (FPU selectable).
	8	AO1	O	Auxiliary output 1 (FPU selectable).
	9	AO2	O	Auxiliary output 2 (FPU selectable).
	10	RS1	O	Remote speaker output.
	11	RS2	O	Remote speaker output.
	12	-	-	Non connection.

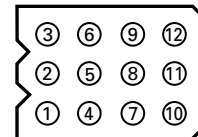

# TK-790/(B)/H(B) TK-790/(B)/H(B)

## WIRING

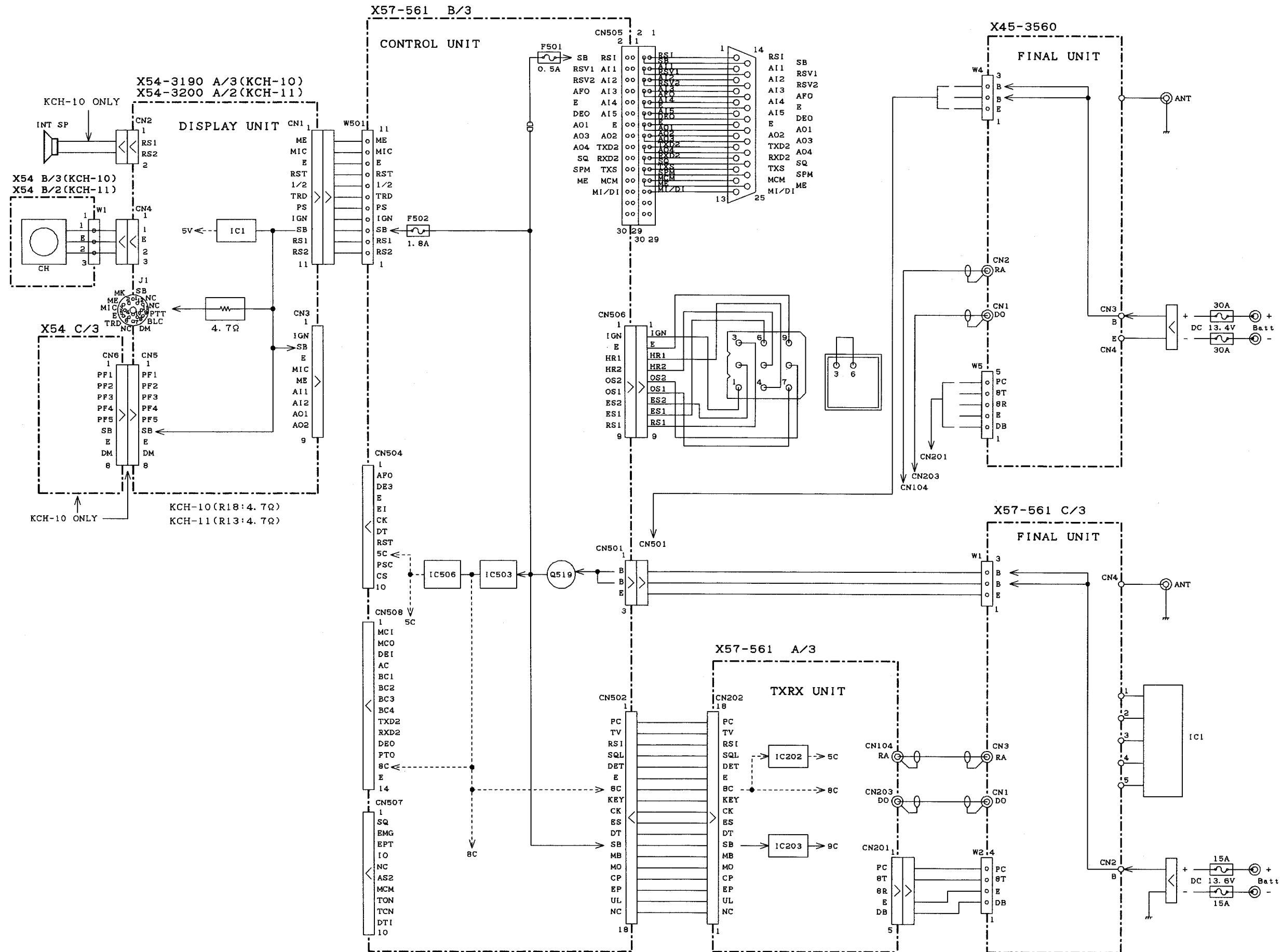

DISPLAY UNIT (X54-3190-20) Component side view : KCH-10

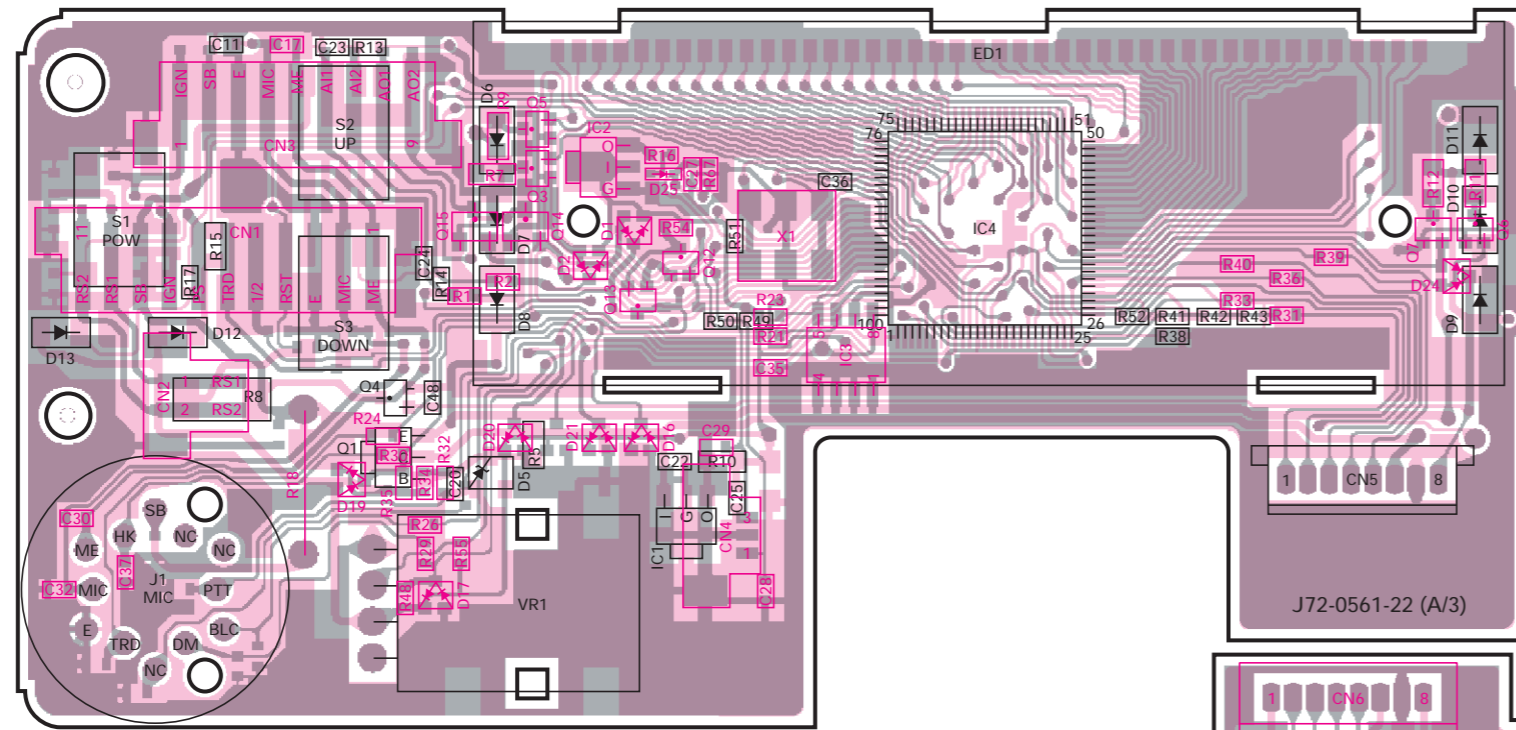

PC BOARD VIEWS TK-790/(B)/H(B)

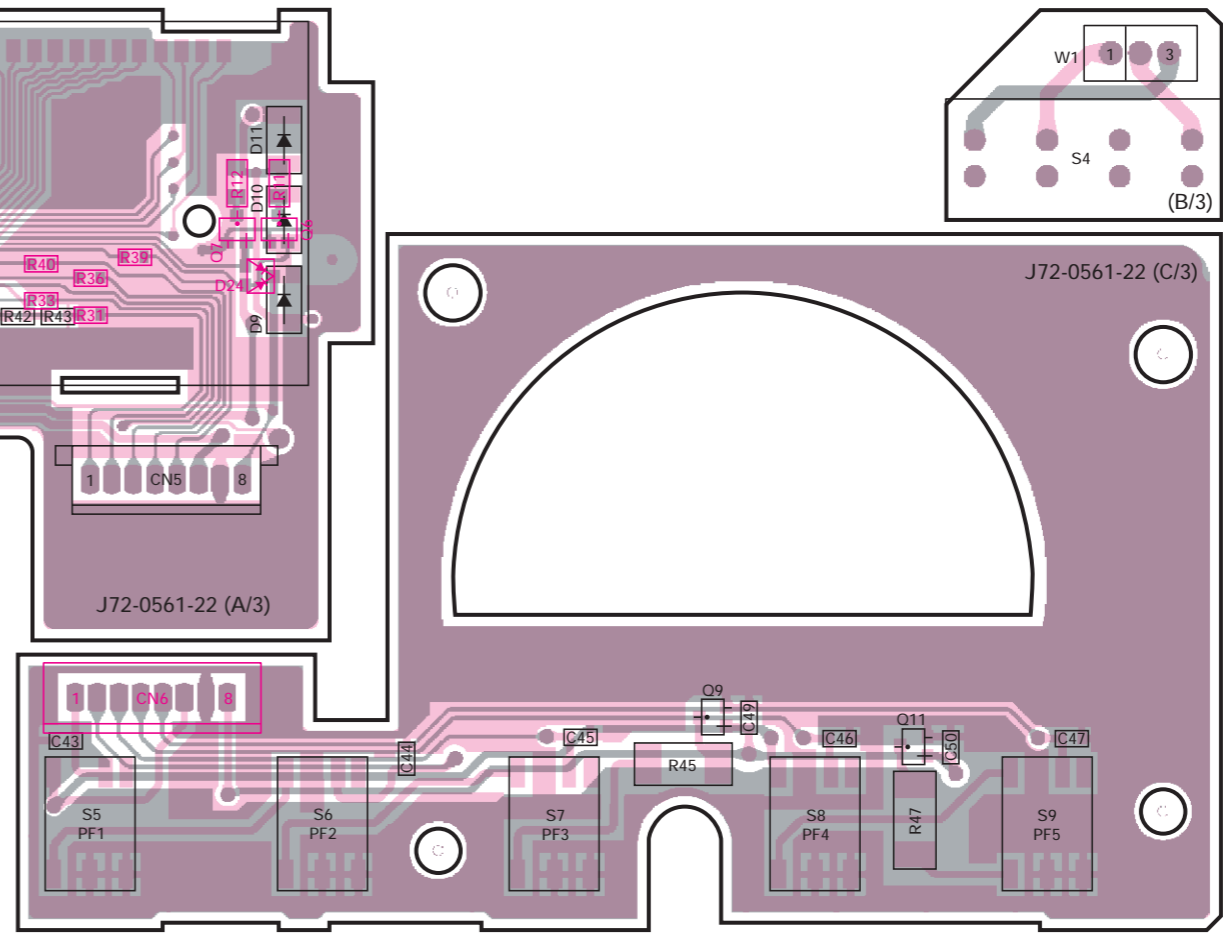

DISPLAY UNIT (X54-3190-20) Foil side view : KCH-10

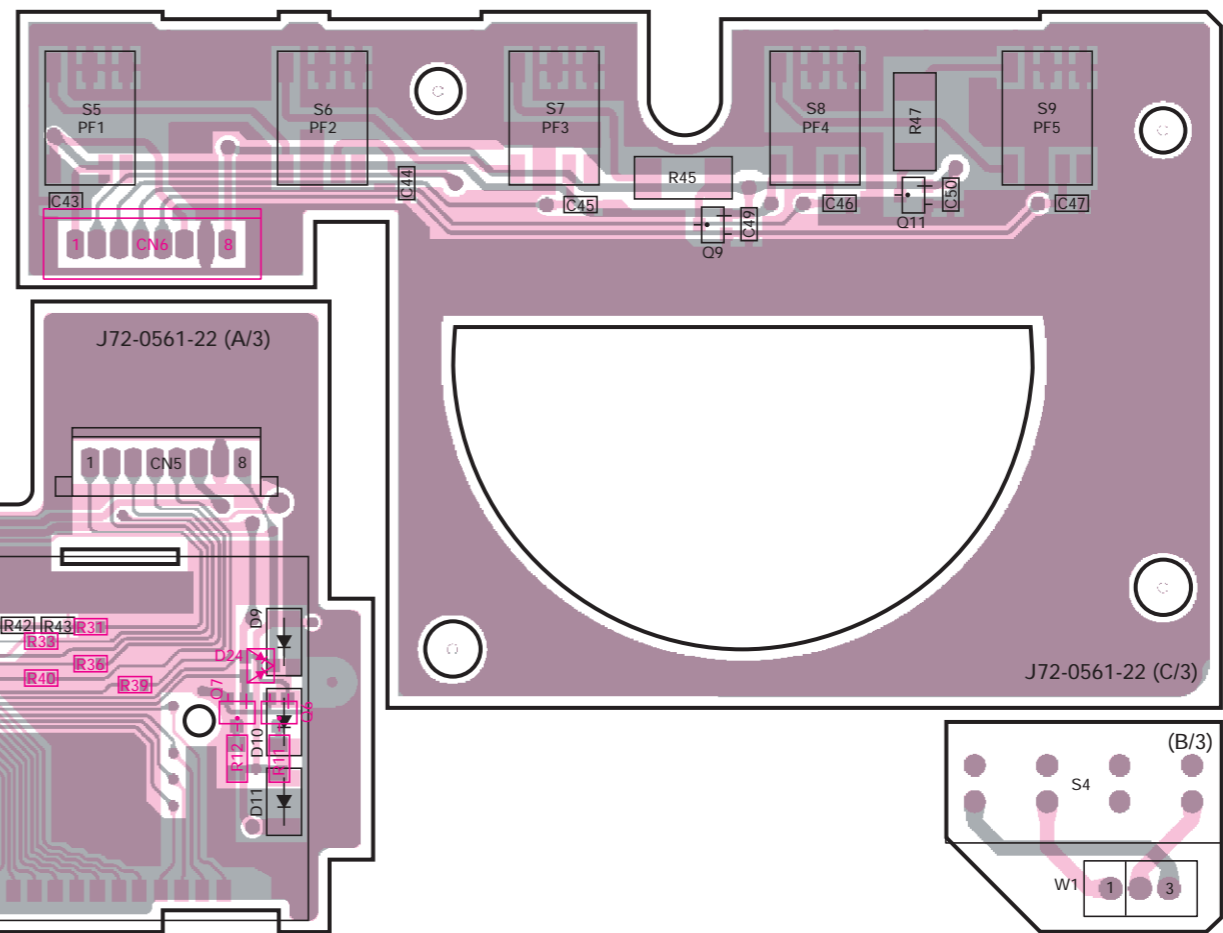
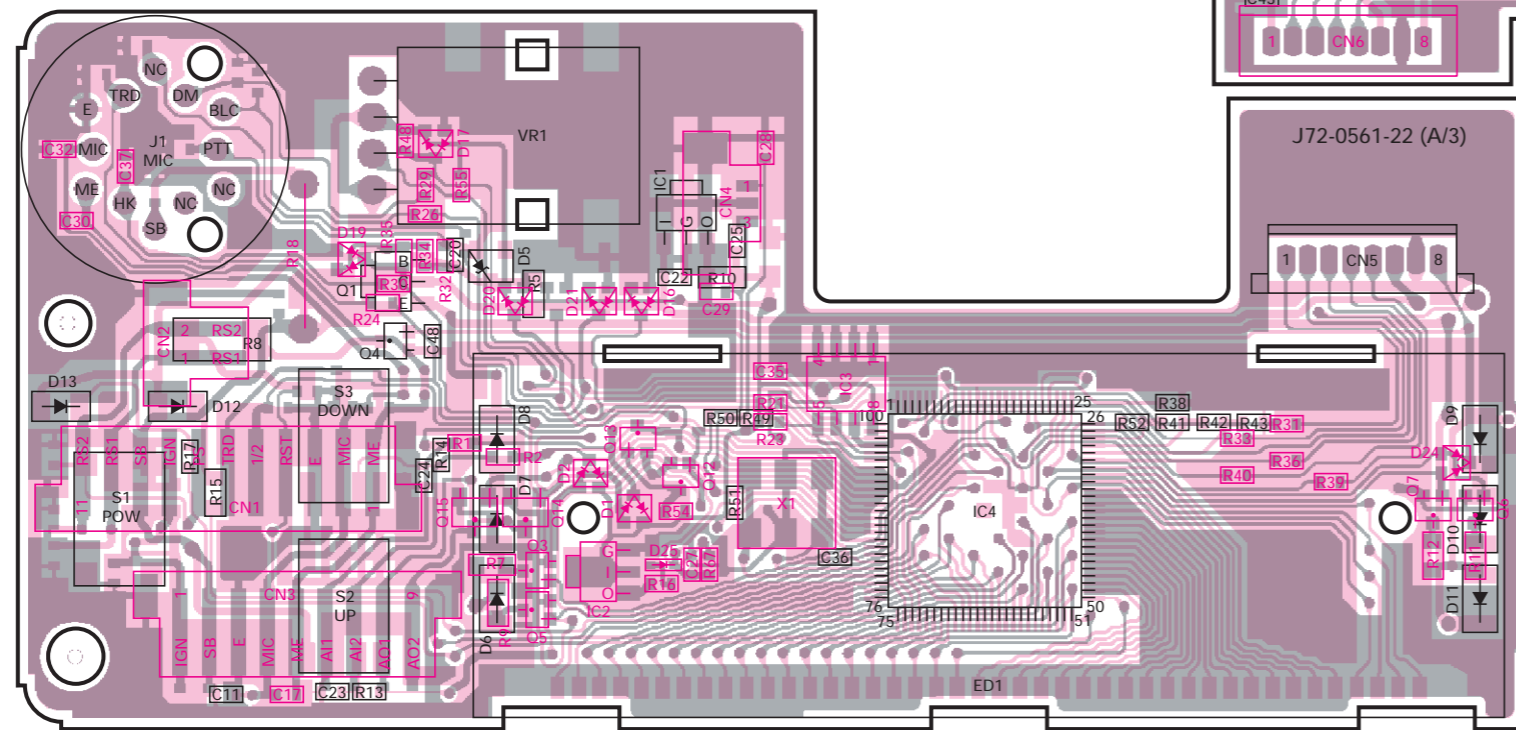

# TK-790/(B)/H(B) PC BOARD VIEWS

Component side  
Foil side

DISPLAY UNIT (X54-3200-20) Component side view : KCH-11

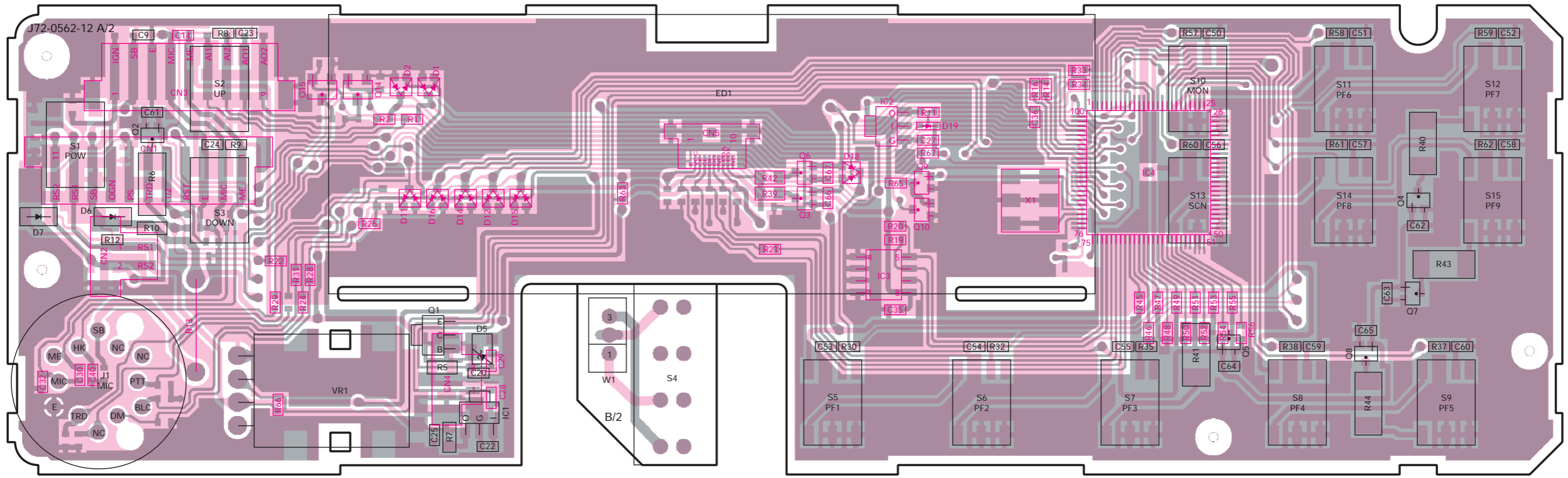

DISPLAY UNIT (X54-3200-20) Foil side view : KCH-11

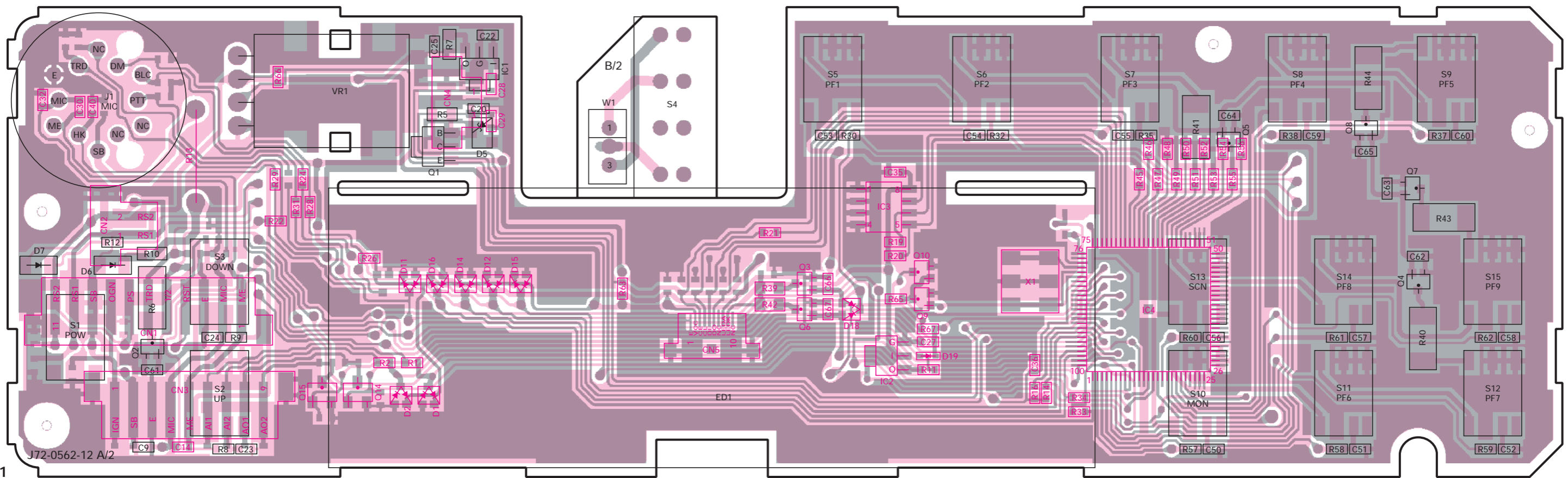

Note : Components marked with a dot (·) are parts of pattern 1.

# CIRCUIT DIAGRAM TK-790/(B)/H(B)

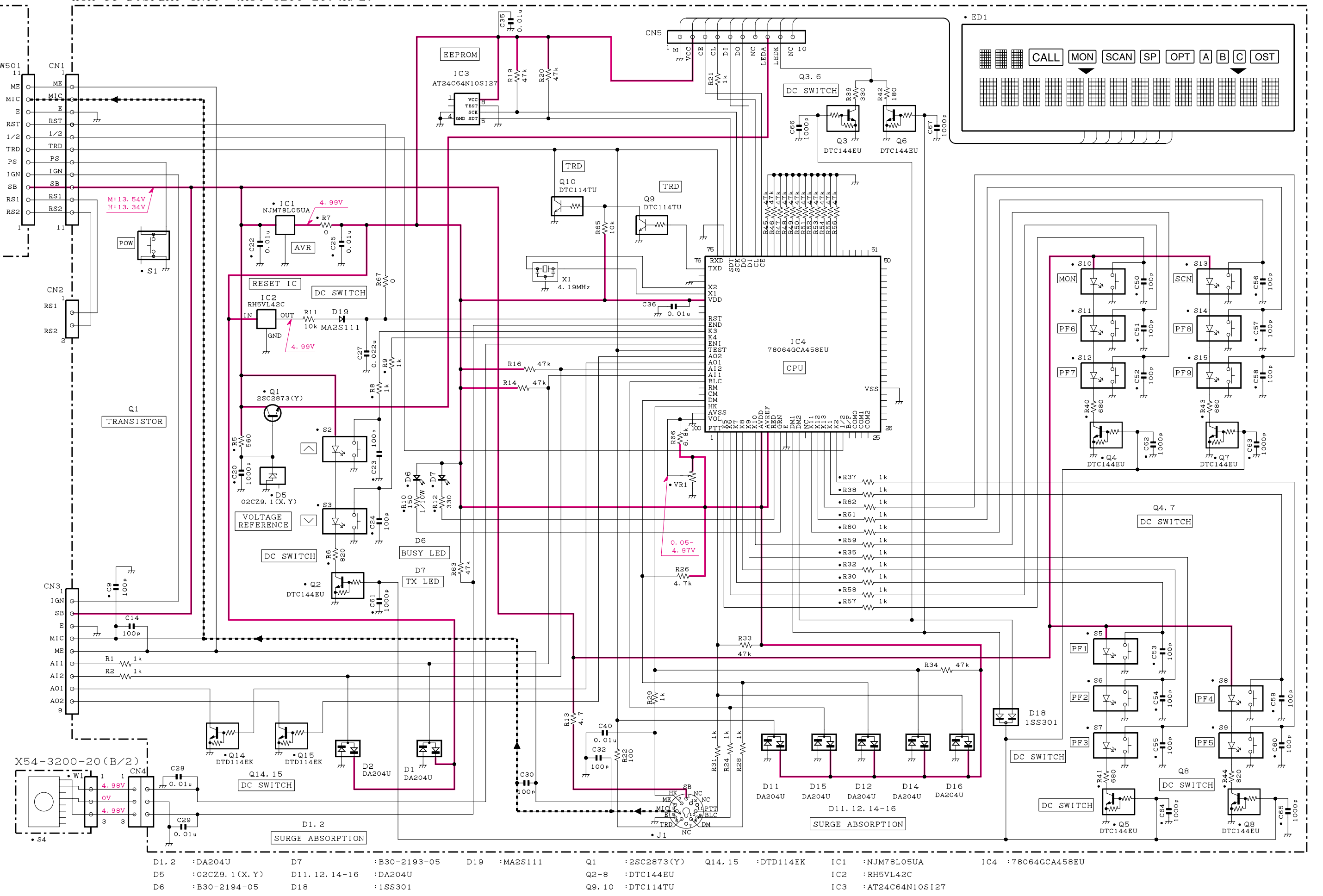
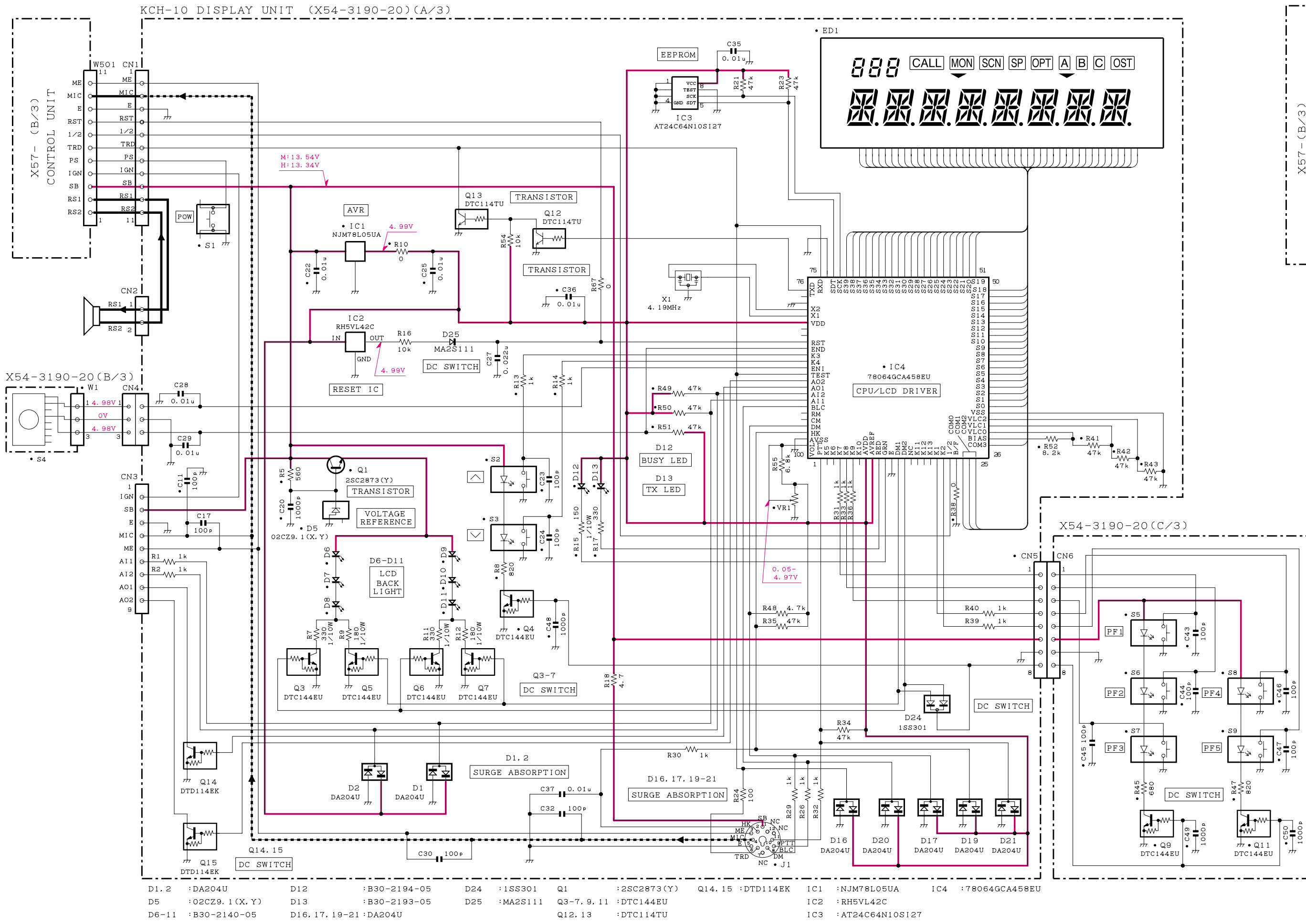

# TK-790/(B)/H(B) CIRCUIT DIAGRAM

Note : Components marked with a dot (·) are parts of pattern 1.

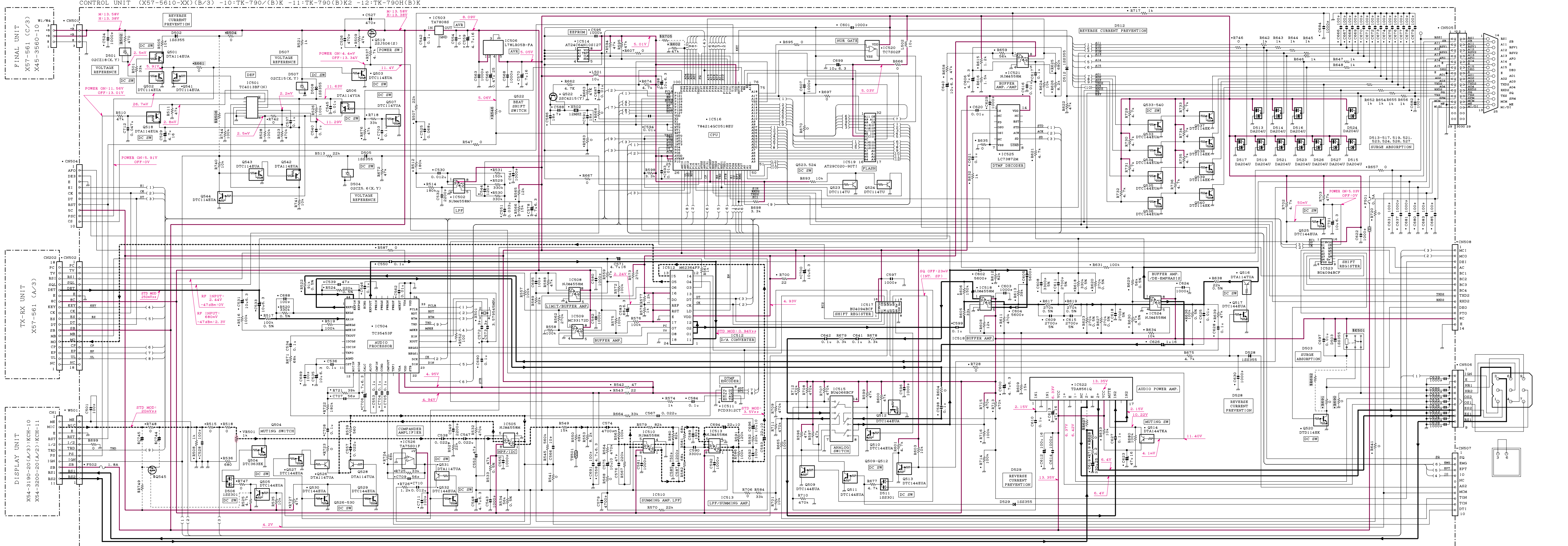

D501	·02C218(X.Y)	D504	·02C25.6(X.Y)	D513-517, 519, 521	·DA204U	Q501, 518, 542	·DTA144UA	Q504	·DTC363EK	Q506	·DTA1147UA	Q516, 526, 528, 531	·DTA1147UA	Q522	·28C4215(Y)	IC501	·TC4013BF(N)	IC503	·T78088	IC509	·MC33172D	IC514	·AT24C64N10S127	IC517, 523	·BU4094BCF	IC522	·TA75501F
D502, 503, 505, 508	·1S3355	D506, 511	·1S8301	523, 524, 526, 527		Q502, 503, 541	·DTC1147UA	Q505, 509-513, 517, 525	·DTC144UA	Q507	·DTC1147UA	Q519	·DTC1147UA	Q523, 524	·DTC1147U	IC502, 505, 508, 510	·NJM4558M	IC504	·TC35453F	IC511	·PCD3312CT	IC515	·BU4066BCF	IC519	·AT29C020-90T1	IC525	·LC73872M
512, 528, 529		D507	·02C215(X.Y)	543, 544		Q527, 529, 530, 532-536		Q514	·DTA144TKA	Q520, 537-540	·DPTD114EK				513, 518, 521, 524		IC506	·L78L05B-PA	IC512	·M62364FP	IC516	·784214G0C0518EU	IC520	·TC7502F	IC526	·TA75501F	



# TK-790/(B)/H(B) PC BOARD VIEW

CONTROL UNIT (X57-5610-XX) (B/3) -10 : TK-790/(B) K -11 : TK-790(B) K2 -12 : TK-790H(B) K Foil side view

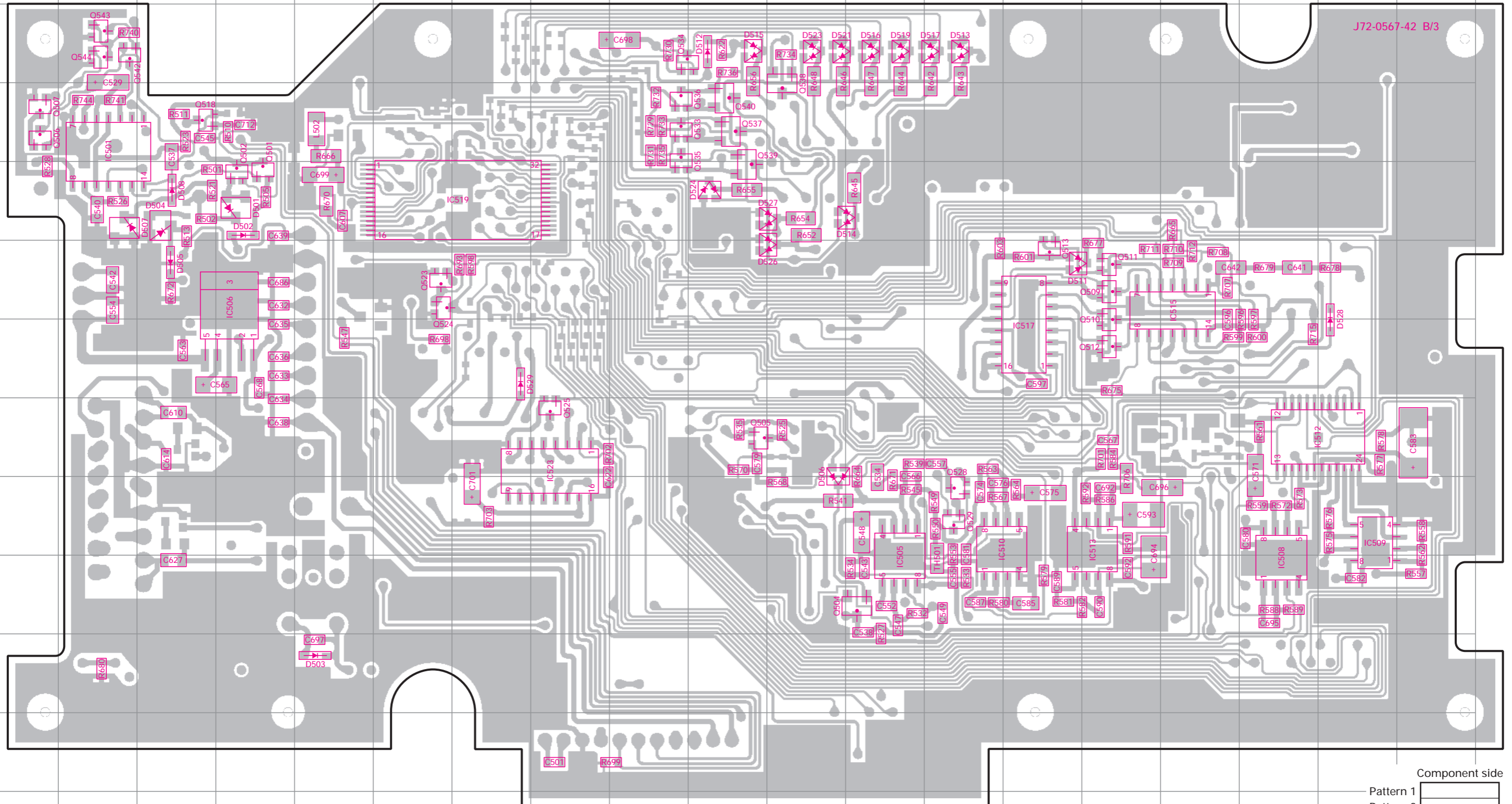

Ref No.	Address	Ref No.	Address	Ref No.	Address	Ref No.	Address	Ref No.	Address	Ref No.	Address	Ref No.	Address	Ref No.	Address	Ref No.	Address	Ref No.	Address		
IC501	3B	IC512	7Q	Q501	4D	Q509	5O	Q523	5F	Q534	2I	Q540	3J	D503	10E	D511	5N	D517	2M	D527	4K
IC505	8L	IC513	8O	Q502	4D	Q510	6O	Q524	5F	Q535	3I	Q542	2B	D504	4C	D512	2J	D519	2L	D528	6R
IC506	5D	IC515	5P	Q504	9L	Q511	5O	Q525	7H	Q536	3I	Q543	2B	D505	5C	D513	2M	D521	2K	D529	6G
IC508	9Q	IC517	6N	Q505	7J	Q512	6O	Q528	8M	Q537	3J	Q544	2B	D506	7K	D514	4L	D523	2K		
IC509	8R	IC519	4G	Q506	3A	Q513	5N	Q529	8M	Q538	2K	D501	4D	D507	4B	D515	2J	D524	4J		
IC510	8M	IC523	7H	Q507	3A	Q518	3C	Q533	3I	Q539	4J	D502	4D	D508	4C	D516	2L	D526	5K		

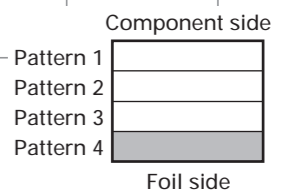



# TK-790/(B) PC BOARD VIEWS

FINAL UNIT (X57-5610-XX) (C/3) -10 : TK-790/(B) K -11 : TK-790(B) K2 Component side view

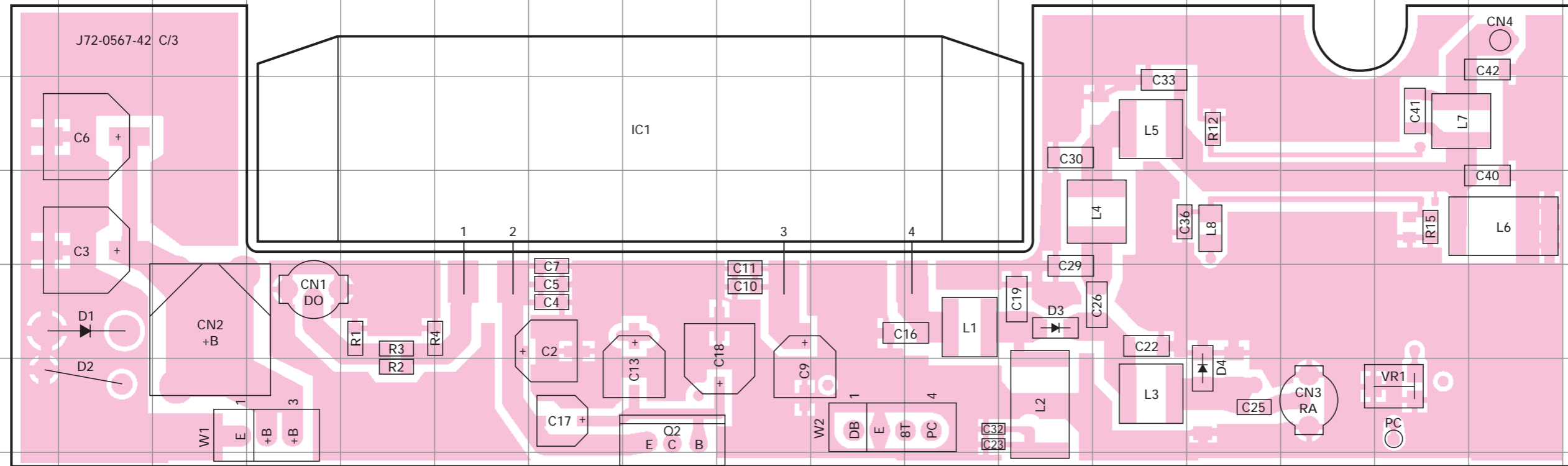

Ref No.	Address
IC1	3H
Q2	6H
D1	5B
D2	6B
D3	5L
D4	6N

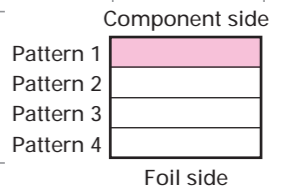

FINAL UNIT (X57-5610-XX) (C/3) -10 : TK-790/(B) K -11 : TK-790(B) K2 Foil side view

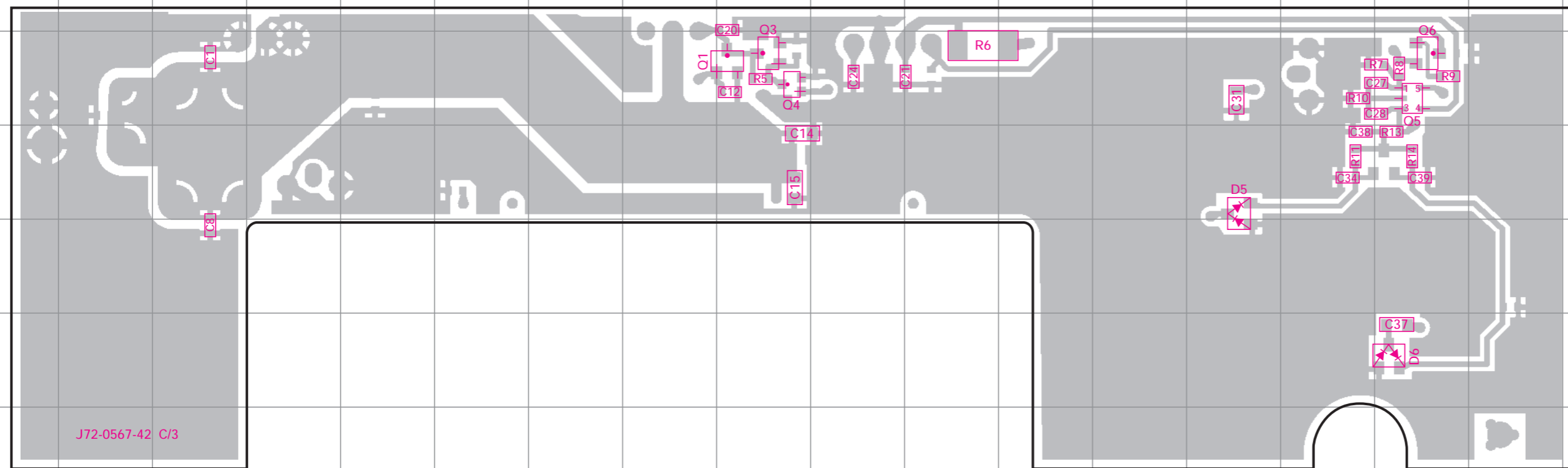

Ref No.	Address
Q1	9I
Q3	9I
Q4	9I
Q5	9P
Q6	9P
D5	10N
D6	12P

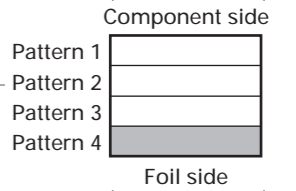

# PC BOARD VIEW TK-790/(B)

FINAL UNIT (X57-5610-XX) (C/3) -10 : TK-790/(B) K -11 : TK-790(B) K2 Component side view + Foil side

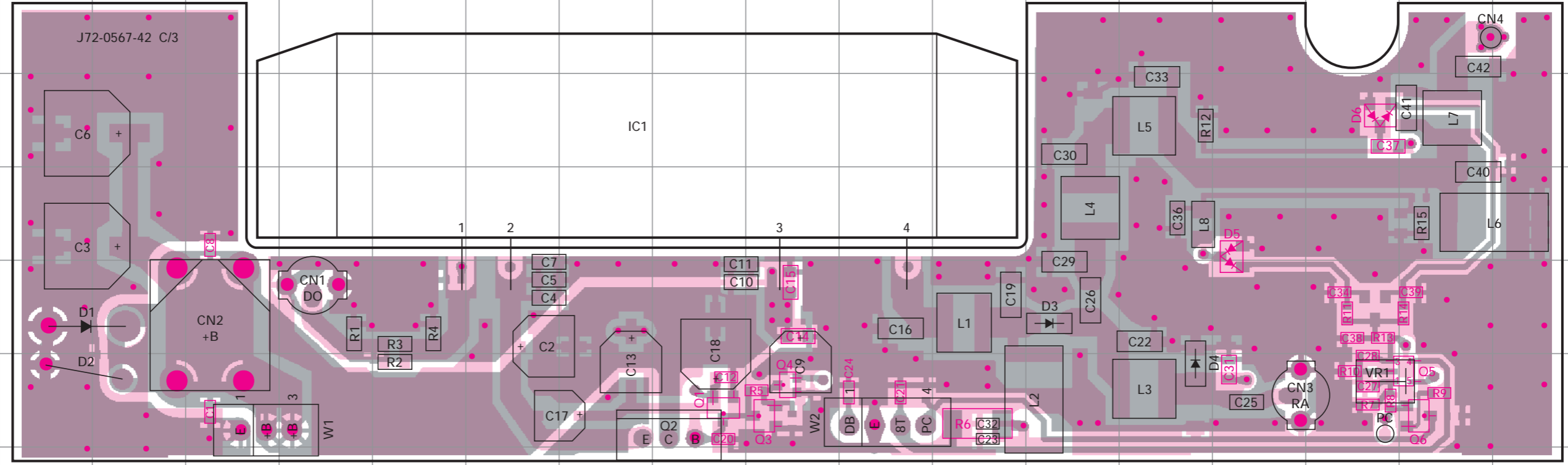

Ref No.	Address	Ref No.	Address	Ref No.	Address
IC1	3H	Q5	6Q	D4	6N
Q1	6I	Q6	6Q	D5	4O
Q2	6I	D1	5B	D6	3P
Q3	6J	D2	6B		
Q4	6J	D3	5M		

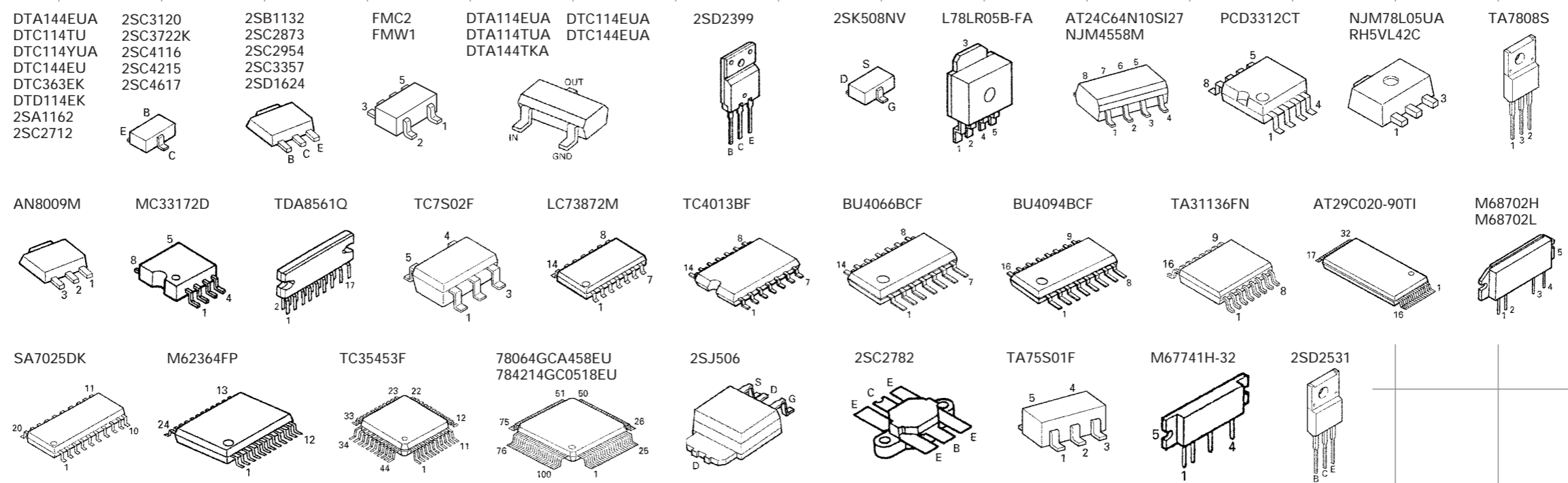
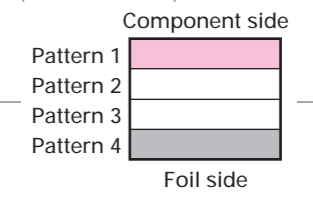



# PC BOARD VIEW TK-790/(B)/H(B)

TX-RX UNIT (X57-5610-XX) (A/3) -10 : TK-790/(B) K -11 : TK-790(B) K2 -12 : TK-790H(B) K Foil side view

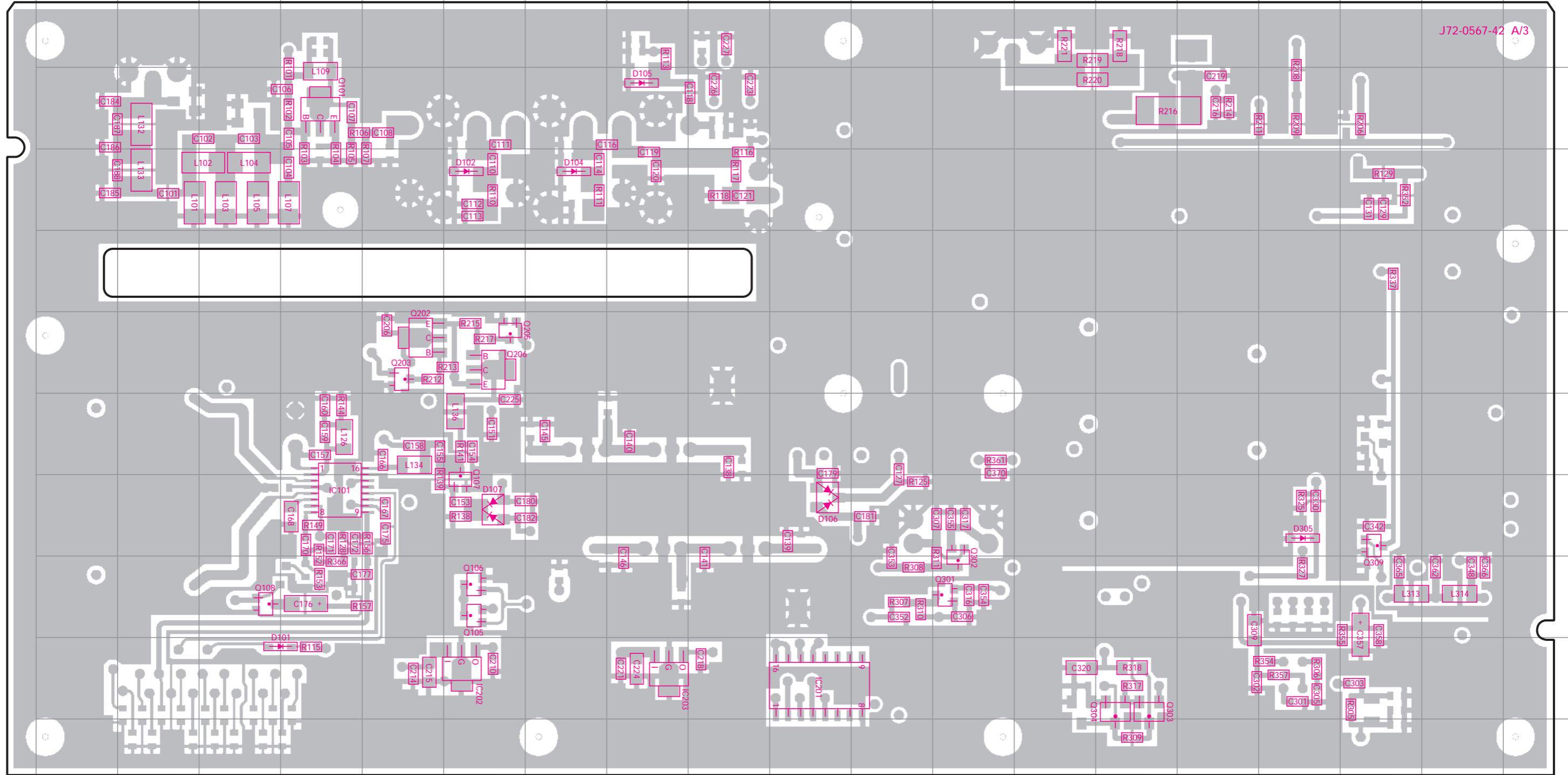

J72-0567-42 A/3

Ref No.	Address	Ref No.	Address	Ref No.	Address	Ref No.	Address
IC101	8D	Q107	8F	Q302	9L	D105	3H
IC201	10J	Q108	9C	Q303	10N	D106	8J
IC202	10F	Q202	6E	Q304	10N	D107	8F
IC203	10H	Q203	6E	Q309	8Q	D305	8P
Q101	3D	Q205	6F	D101	10C		
Q105	9F	Q206	6F	D102	4F		
Q106	9F	Q301	9L	D104	4G		

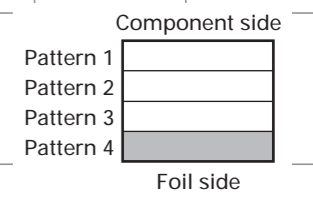

# TK-790/(B)/H(B) PC BOARD VIEW

TX-RX UNIT (X57-5610-XX) (A/3) -10 : TK-790/(B) K -11 : TK-790(B) K2 -12 : TK-790H(B) K Component side view + Foil side

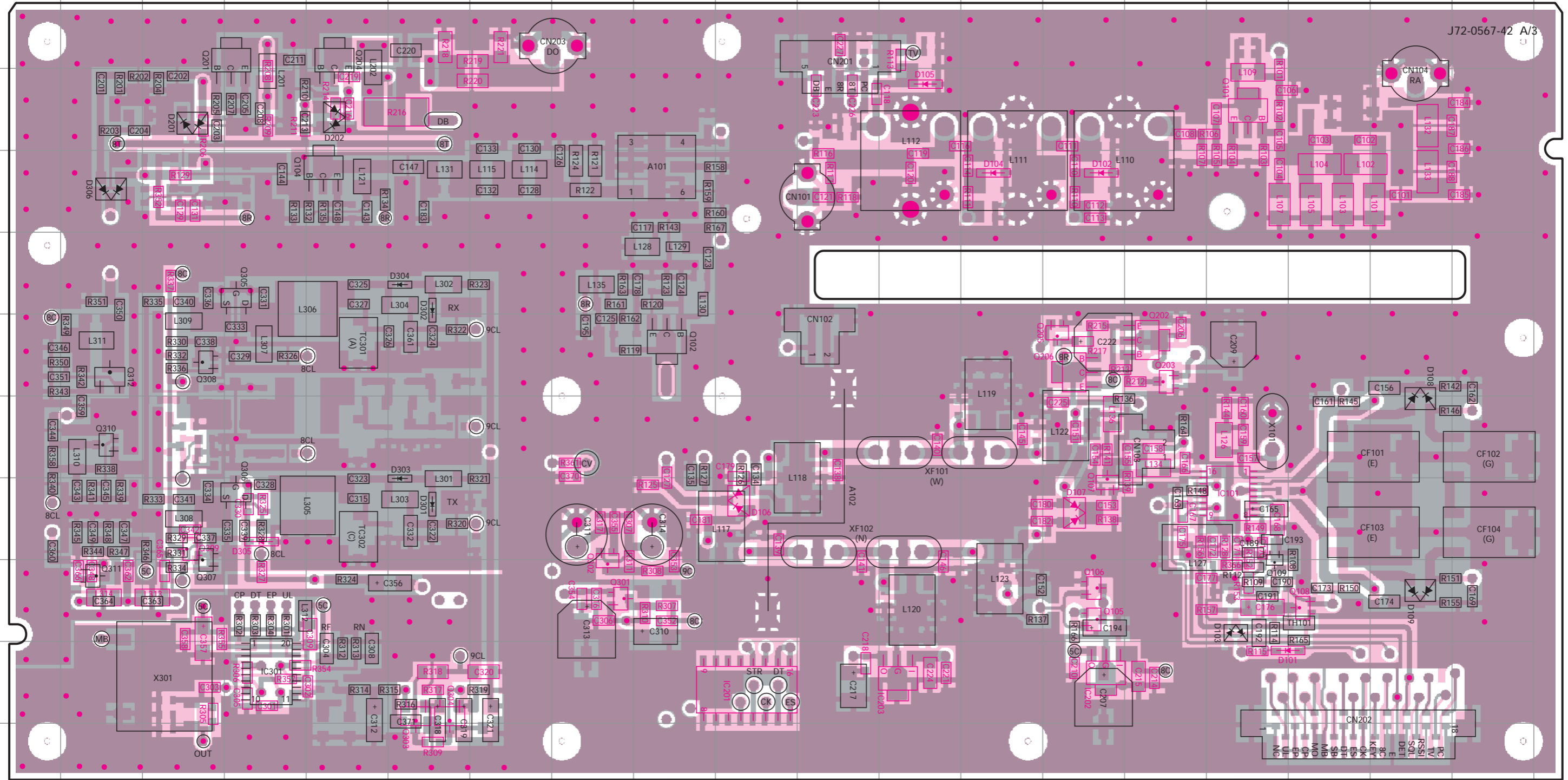

J72-0567-42 A/3

Ref No.	Address	Ref No.	Address	Ref No.	Address	Ref No.	Address	Ref No.	Address	Ref No.	Address	Ref No.	Address
IC101	8P	Q104	4E	Q202	6O	Q303	10F	Q310	7B	D105	3L	D301	8F
IC201	10J	Q105	9N	Q203	6O	Q304	10F	Q311	9B	D106	8J	D302	5F
IC202	10N	Q106	9N	Q204	2E	Q305	5D	Q312	6B	D107	8N	D303	8F
IC203	10L	Q107	8N	Q205	6N	Q306	8D	D101	10Q	D108	7R	D304	5F
IC301	10D	Q108	9Q	Q206	6N	Q307	9C	D102	4N	D109	9R	D305	8D
Q101	3P	Q109	9P	Q301	9H	Q308	6C	D103	9P	D201	3C	D306	4B
Q102	6I	Q201	2D	Q302	9H	Q309	8C	D104	4M	D202	3E		

Component side

Pattern 1

Pattern 2

Pattern 3

Pattern 4

Foil side

● Connect 1 and 4



# TK-790H(B) CIRCUIT DIAGRAM

Note : Components marked with a dot (·) are parts of pattern 1.

TX-RX UNIT (X57-5610-12) (A/3) :TK-790H(B)K

FINAL UNIT (X45-3560-10) :TK-790H(B)K

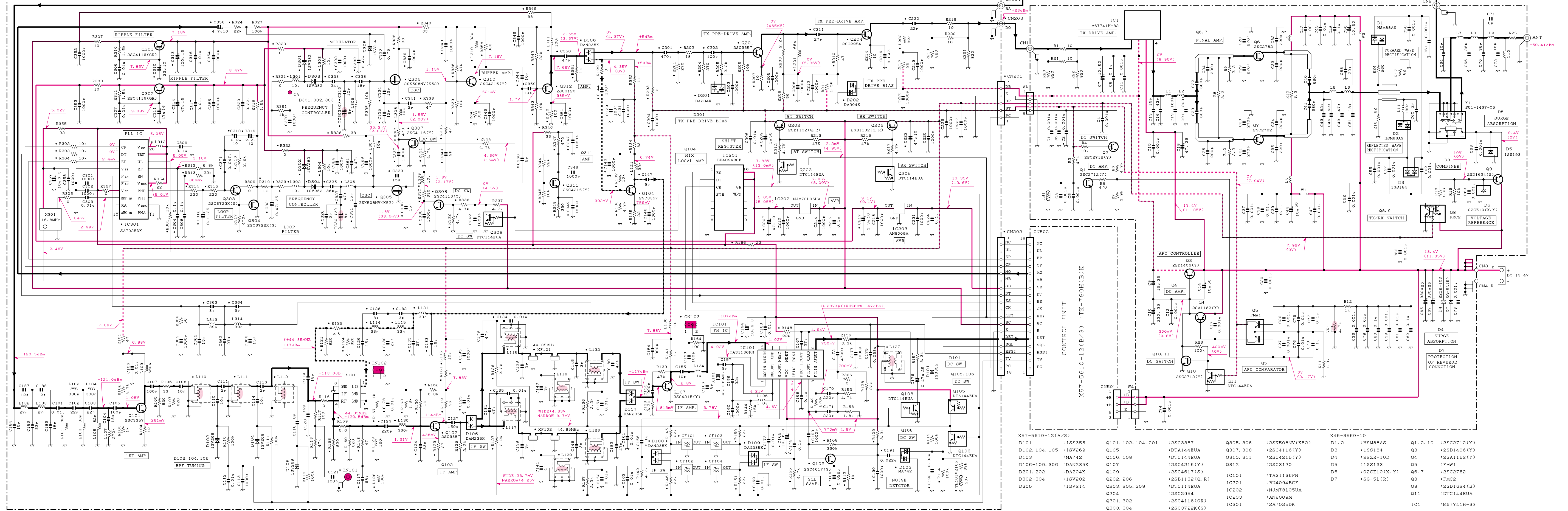

X57-5610-12(A/3)	Q101. 102. 104. 201	:2SC3357	Q305. 306	:2SK508NV(K52)	X45-3560-10	Q1. 2. 10	:2SC2712(Y)
D101	:1SS355	Q105	:DTA144EUA	Q307. 308	:2SC4116(Y)	D3	:1SS184
D102. 104. 105	:1SV269	D103	:MA742	Q310. 311	:2SC4215(Y)	D4	:22Z-10D
D106-109. 306	:DAN235K	Q107	:2SC3120	Q312	:2SC3120	D5	:1SS193
D201. 202	:DA204K	Q109	:2SC4617(S)	IC101	:TA31136FN	D6	:02C210(X.Y)
Q202. 206	:1SV282	Q202. 206	:2SB1132(G.R)	IC202	:NJM78L05UA	Q6. 7	:2SC2782
D302-304	:1SV214	Q203. 205. 309	:DTC114EUA	IC201	:BU4094BCF	D7	:FMC2
D305	:1SV214	Q204	:2SC2954	IC202	:NJM78L05UA	Q8	:2SD1624(S)
		Q301. 302	:2SC2954	IC203	:AN8009M	Q9	:DTC144EUA
		Q303. 304	:2SC3722K(S)	IC301	:SA7025DK	IC1	:M67741H-32

FINAL UNIT (X45-3560-10) Component side view : TK-790H(B)

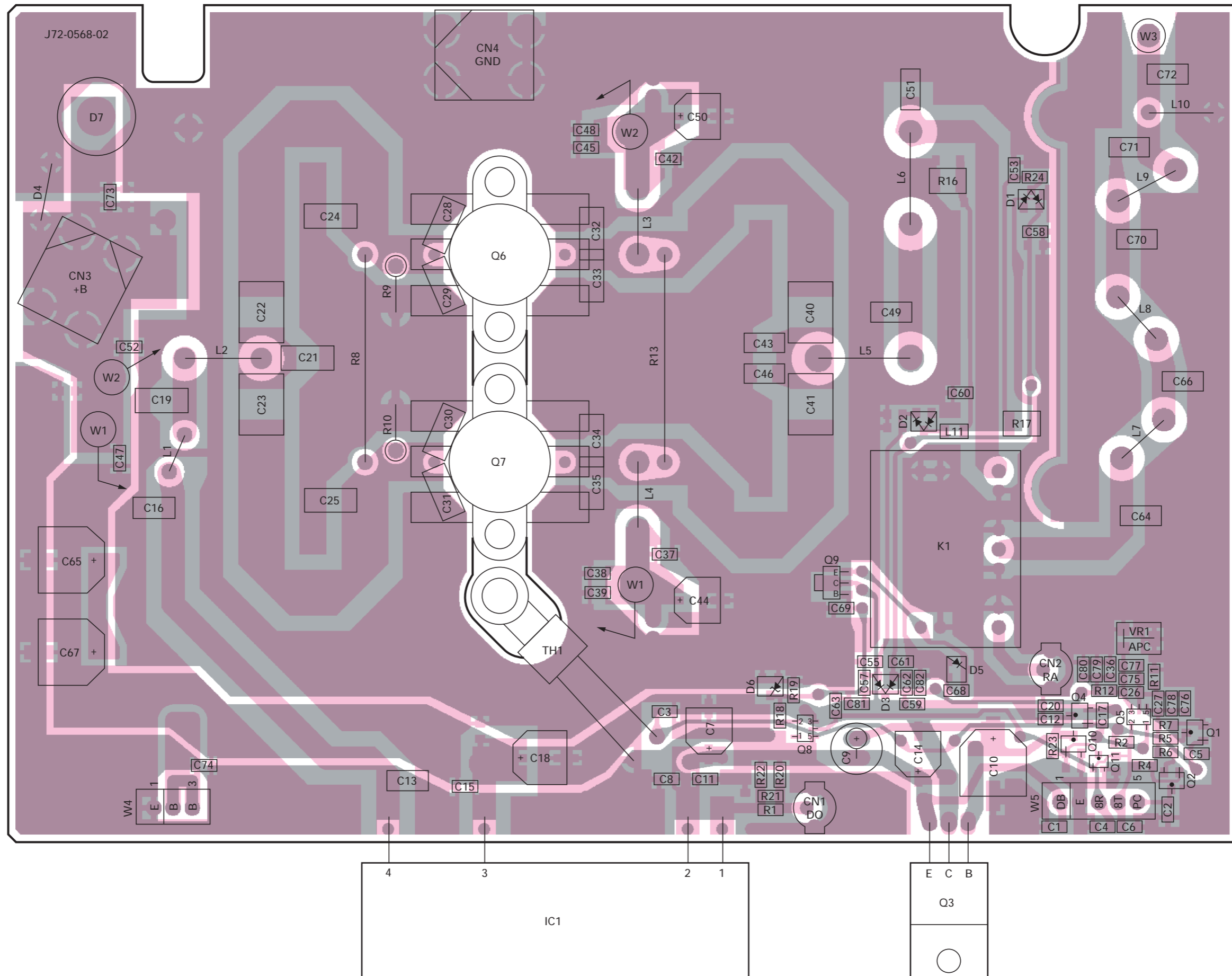

# TK-790/(B)/H(B) TK-790/(B)/H(B)

## BLOCK DIAGRAM

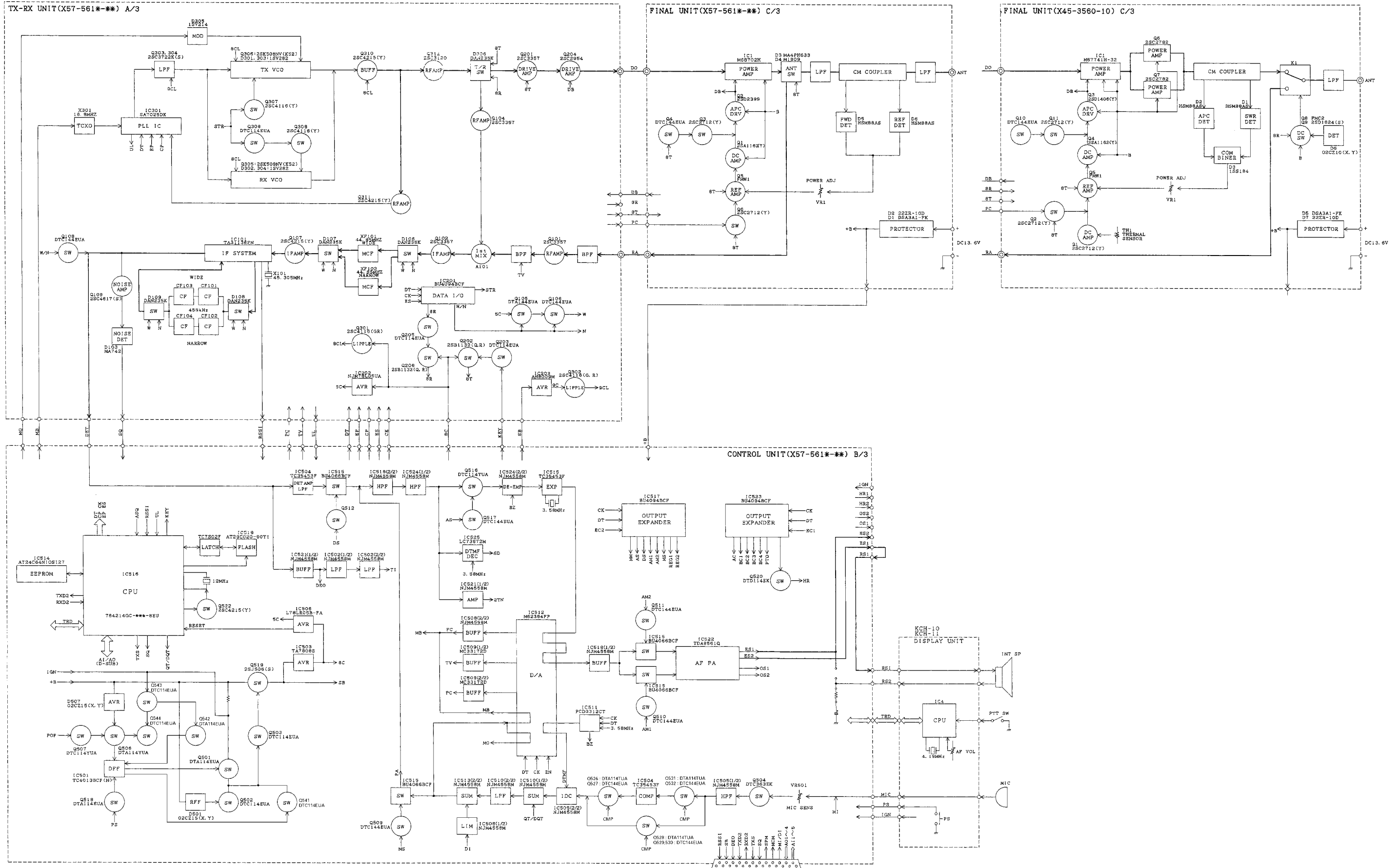

## SPECIFICATIONS

### GENERAL

Frequency Range .....	TK-790 : 148 to 174MHz (K), 136 to 156MHz (K2)	TK-790H : 148 to 174MHz (K)
Number of Channels .....	160 channels	
Channel Spacing .....	30kHz, 25kHz (Wide) / 15kHz, 12.5kHz (Narrow)	
Operating Voltage .....	TK-790 : 13.6V DC±15%, TK-790H : 13.4V DC±15% negative ground	
Current Drain .....	0.6A on standby 2.2A on receive TK-790 : 12A, TK-790H : 25A on transmit	
Duty Cycle .....	Transmit 20%	
Frequency Stability .....	±0.0002% (-30°C to +60°C)	
Operating Temperature Range .....	-30°C to +60°C (-22°F to +140°F)	
Dimensions & Weight .....	TK-790 : 7.01" (178mm) W x 2.36" (60mm) H x 7.68" (195mm) D, 5.61lbs (2.3kg) 7.01" (178mm) W x 2.36" (60mm) H x 8.98" (228mm) D, 5.72lbs (2.6kg) with KCH-10 TK-790H : 7.01" (178mm) W x 2.36" (60mm) H x 12.88" (327mm) D, 7.92lbs (3.6kg)	

### RECEIVER (Measurements made per EIA standard EIA/TIA-240-D)

Antenna Impedance .....	50Ω
Sensitivity .....	12dB SINAD : 0.25μV, 20dB Quieting : 0.35μV
Selectivity .....	85dB (Wide) / 80dB (Narrow)
Intermodulation .....	80dB (Wide) / 75dB (Narrow)
Spurious and Image Rejection .....	90dB
Audio Output .....	13W at 4Ω less than 5% distortion (12W at 4Ω less than 3% distortion)
Band Spread .....	TK-790 : 26MHz (K), 20MHz (K2)      TK-790H : 26MHz (K)

### TRANSMITTER (Measurements made per EIA standard EIA-152-C)

RF Power Output .....	TK-790 : 45W adjustable to 5W, TK-790H : 110W adjustable to 45W
Antenna Impedance .....	50Ω
Spurious Response .....	80dB
Type of Emission .....	16K0F3E (Wide) / 11K0F3E (Narrow)
FM Hum and Noise .....	53dB (Wide) / 47dB (Narrow)
Microphone Impedance .....	600Ω
Audio Distortion .....	Less than 2% at 1000Hz
Band Spread .....	TK-790 : 26MHz (K), 20MHz (K2)      TK-790H : 26MHz (K)

KENWOOD follows a policy of continuous advancement in development. For this reason, specifications may be changed without notice.

### APPLICABLE (MIL-STD)

Military Standard	Method/Procedures		
	810C	810D	810E
Low Pressure	500.1/Procedure I	500.2/Procedure I, II	500.3/Procedure I, II
High temperature	501.1/Procedure I, II	501.2/Procedure I, II Cat, A1	501.3/Procedure I, II Cat, A1
Low Temperature	502.1/Procedure I	502.2/Procedure I, II Cat, C1	502.3/Procedure I, II Cat, C1
Temperature Shock	503.1/Procedure I	503.2/Procedure I Cat, A1,C1	503.3/Procedure I Cat, A1,C1
Solar Radiation	505.1/Procedure I	505.2/Procedure I	505.3/Procedure I
Rain (Procedure I : Control head only)	506.1/Procedure I, II	506.2/Procedure I, II	506.3/Procedure I, II
Humidity	507.1/Procedure II	507.2/Procedure II	507.3/Procedure II
Salt Fog	509.1/Procedure I	509.2/Procedure I	509.3/Procedure I
Dust	510.1/Procedure I	510.2/Procedure I	510.3/Procedure I
Vibration	514.2/Procedure VⅢ, X	514.3/Procedure I Cat, 8	514.4/Procedure I Cat, 8
Shock	516.2/Procedure I, II, V	516.3/Procedure I, IV	516.4/Procedure I, IV

# TK-790/(B)/H(B)

## **KENWOOD CORPORATION**

14-6, Dogenzaka 1-chome, Shibuya-ku, Tokyo 150-8501, Japan

### **KENWOOD SERVICE CORPORATION**

P.O. BOX 22745, 2201 East Dominguez Street, Long Beach, CA 90801-5745, U.S.A.

### **KENWOOD ELECTRONICS CANADA INC.**

6070 Kestrel Road, Mississauga, Ontario, Canada L5T 1S8

### **KENWOOD ELECTRONICS DEUTSCHLAND GMBH**

Rembrücker Str. 15, 63150 Heusenstamm, Germany

### **KENWOOD ELECTRONICS BELGIUM N.V.**

Mechelsesteenweg 418 B-1930 Zaventem, Belgium

### **KENWOOD ELECTRONICS FRANCE S.A.**

13, Boulevard Ney, 75018 Paris, France

### **KENWOOD ELECTRONICS U.K. LIMITED**

KENWOOD House, Dwight Road, Watford, Herts., WD1 8EB United Kingdom

### **KENWOOD ELECTRONICS EUROPE B.V.**

Amsterdamseweg 37, 1422 AC Uithoorn, The Netherlands

### **KENWOOD ELECTRONICS ITALIA S.p.A.**

Via G. Sirtori, 7/9 20129 Milano, Italy

### **KENWOOD IBERICA S.A.**

Bolivia, 239-08020 Barcelona, Spain

### **KENWOOD ELECTRONICS AUSTRALIA PTY. LTD.**

(A.C.N. 001 499 074)

16 Giffnock Avenue, Centrecourt Estate, North Ryde, N.S.W. 2113 Australia

### **KENWOOD ELECTRONICS (HONG KONG) LTD.**

Unit 3712-3724, Level 37, Tower one Metroplaza, 223 Hing Fong Road, Kwai Fong, N.T., Hong Kong

### **KENWOOD ELECTRONICS TECHNOLOGIES(S) PTE LTD.**

Sales Marketing Division

1 Ang Mo Kio Street 63, Singapore 569110

