

SIMATIC

ET 200SP Product information on the documentation of the ET 200SP distributed I/O system

Product Information

Preface

Module overview of
ET 200SP

1



Supplements to ET 200SP
documentation

2

Legal information

Warning notice system

This manual contains notices you have to observe in order to ensure your personal safety, as well as to prevent damage to property. The notices referring to your personal safety are highlighted in the manual by a safety alert symbol, notices referring only to property damage have no safety alert symbol. These notices shown below are graded according to the degree of danger.

 DANGER
indicates that death or severe personal injury will result if proper precautions are not taken.
 WARNING
indicates that death or severe personal injury may result if proper precautions are not taken.
 CAUTION
indicates that minor personal injury can result if proper precautions are not taken.
NOTICE
indicates that property damage can result if proper precautions are not taken.

If more than one degree of danger is present, the warning notice representing the highest degree of danger will be used. A notice warning of injury to persons with a safety alert symbol may also include a warning relating to property damage.

Qualified Personnel

The product/system described in this documentation may be operated only by **personnel qualified** for the specific task in accordance with the relevant documentation, in particular its warning notices and safety instructions. Qualified personnel are those who, based on their training and experience, are capable of identifying risks and avoiding potential hazards when working with these products/systems.

Proper use of Siemens products

Note the following:

 WARNING
Siemens products may only be used for the applications described in the catalog and in the relevant technical documentation. If products and components from other manufacturers are used, these must be recommended or approved by Siemens. Proper transport, storage, installation, assembly, commissioning, operation and maintenance are required to ensure that the products operate safely and without any problems. The permissible ambient conditions must be complied with. The information in the relevant documentation must be observed.

Trademarks

All names identified by ® are registered trademarks of Siemens AG. The remaining trademarks in this publication may be trademarks whose use by third parties for their own purposes could violate the rights of the owner.

Disclaimer of Liability

We have reviewed the contents of this publication to ensure consistency with the hardware and software described. Since variance cannot be precluded entirely, we cannot guarantee full consistency. However, the information in this publication is reviewed regularly and any necessary corrections are included in subsequent editions.

Preface

Validity

This product information supplements the documentation for the ET 200SP and takes precedence over our system manuals, function manuals and product manuals.

Security information

Siemens provides products and solutions with industrial security functions that support the secure operation of plants, systems, machines and networks.

In order to protect plants, systems, machines and networks against cyber threats, it is necessary to implement – and continuously maintain – a holistic, state-of-the-art industrial security concept. Siemens' products and solutions only form one element of such a concept.

Customer is responsible to prevent unauthorized access to its plants, systems, machines and networks. Systems, machines and components should only be connected to the enterprise network or the internet if and to the extent necessary and with appropriate security measures (e.g. use of firewalls and network segmentation) in place.

Additionally, Siemens' guidance on appropriate security measures should be taken into account. For more information about industrial security, please visit (<http://www.siemens.com/industrialsecurity>).

Siemens' products and solutions undergo continuous development to make them more secure. Siemens strongly recommends to apply product updates as soon as available and to always use the latest product versions. Use of product versions that are no longer supported, and failure to apply latest updates may increase customer's exposure to cyber threats.

To stay informed about product updates, subscribe to the Siemens Industrial Security RSS Feed under (<http://www.siemens.com/industrialsecurity>).

Table of contents

	Preface	3
1	Module overview of ET 200SP	5
1.1	Possible combinations of BaseUnits and I/O modules	5
1.2	CPUs.....	11
1.3	Interface modules.....	13
1.4	BaseUnits.....	14
1.5	I/O modules.....	15
1.6	Motor starters.....	17
1.7	Accessories.....	17
2	Supplements to ET 200SP documentation	21
2.1	System manual	21
2.2	CPU manuals.....	22
2.3	Interface module manuals.....	23
2.4	I/O module manuals.....	26
2.4.1	Digital module device manuals	28
2.4.2	Analog module device manuals.....	33
2.4.3	Communications module manuals.....	42

Module overview of ET 200SP

1.1 Possible combinations of BaseUnits and I/O modules

Contents







This product information includes amendments and corrections to the documentation of the ET 200SP distributed I/O system
(<http://support.automation.siemens.com/WW/view/en/55679227/133300>).

1.1 Possible combinations of BaseUnits and I/O modules

Which I/O modules / motor starters fit on a BaseUnit?

The following table provides an overview of the I/O modules / motor starters that fit on the corresponding compatible BaseUnits:

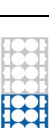
Table 1- 1 Possible combinations of BaseUnits and I/O modules

I/O module	BaseUnit BU15-		BaseUnit BU20-					Color-coded label for process terminals
	BU type A0 P16+A10+2D P16+A0+2D P16+A10+2B P16+A0+2B	BU type A1 P16+A0+12D/T P16+A0+2D/T P16+A0+12B/T P16+A0+2B/T	BU type B0 P12+A4+0B	BU type B1 P12+A0+4B	BU type C0 P6+A2+4D	BU type C1 P6+A2+4B	BU type D0 P12+A0+0B	
Digital I/O modules								
DI 16x24VDC ST	✓							CC00 
DI 8x24VDC ST	✓							CC01 
DI 8x24VDC HF	✓							CC01 
DI 8x24VDC HS	✓							CC01 
DI 8x24VDC BA	✓							CC01 
DI 8x24VDC SRC BA	✓							CC02 
DI 8xNAMUR HF	✓							CC01 









1.1 Possible combinations of BaseUnits and I/O modules

I/O module	BaseUnit BU15-		BaseUnit BU20-						Color-coded label for process terminals	
	BU type A0 P16+A10+2D P16+A0+2D P16+A10+2B P16+A0+2B	BU type A1 P16+A0+12DT P16+A0+2DT P16+A0+12BT P16+A0+2BT	BU type B0 P12+A4+0B	BU type B1 P12+A0+4B	BU type C0 P6+A2+4D	BU type C1 P6+A2+4B	BU type D0 P12+A0+0B	BU type F0 P8+A4+0B		
DI 4x120..230VAC ST				✓					CC41	
DQ 16x24VDC/0.5A ST	✓								CC00	
DQ 4x24VDC/2A ST	✓								CC02	
DQ 8x24VDC/0.5 ST	✓								CC02	
DQ 8x24VDC/0.5A HF	✓								CC02	
DQ 8x24VDC/0.5A BA	✓								CC02	
DQ 8x24VDC/0.5A SNK BA	✓								CC01	
DQ 4x24..230VAC/2A ST				✓					CC41	
DQ 4x24VDC/2A HF	✓								CC02	

1.1 Possible combinations of BaseUnits and I/O modules

I/O module	BaseUnit BU15-		BaseUnit BU20-						Color-coded label for process terminals	
	BU type A0 P16+A10+2D P16+A0+2D P16+A10+2B P16+A0+2B	BU type A1 P16+A0+12D/T P16+A0+2D/T P16+A0+12B/T P16+A0+2B/T	BU type B0 P12+A4+0B	BU type B1 P12+A0+4B	BU type C0 P6+A2+4D	BU type C1 P6+A2+4B	BU type D0 P12+A0+0B	BU type F0 P8+A4+0B		
DQ 4x24VDC/2A HS	✓								CC00	
RQ 4x24VUC/2A CO ST	✓								CC00	
RQ 4x120VDC-230VAC/5A NO ST			✓	✓					---	---
RQ 4x120VDC-230VAC/5A NO MA ST			✓	✓					---	---
Analog I/O modules										
AI 4xRTD/TC 2-/3-/4-wire HF	✓	✓							CC00	
AI 8xRTD/TC 2-wire HF	✓	✓							CC00	
AI 8xU BA	✓	✓							CC02	
AI 2xU ST	✓	✓							CC00	
AI 2xI 2-/4-wire ST	✓	✓							CC05	
AI 4xU/I 2-wire ST	✓	✓							CC03	

1.1 Possible combinations of BaseUnits and I/O modules

I/O module	BaseUnit BU15-		BaseUnit BU20-						Color-coded label for process terminals	
	BU type A0 P16+A10+2D P16+A0+2D P16+A10+2B P16+A0+2B	BU type A1 P16+A0+12DT P16+A0+2DT P16+A0+12BT P16+A0+2BT	BU type B0 P12+A4+0B	BU type B1 P12+A0+4B	BU type C0 P6+A2+4D	BU type C1 P6+A2+4B	BU type D0 P12+A0+0B	BU type F0 P8+A4+0B		
AI 2xU/I 2-/4-wire HF	✓	✓							CC03	
AI 2xU/I 2-/4-wire HS	✓	✓							CC00	
AI 8xI 2-/4-wire BA	✓	✓							CC01	
AI 4xI 2-/4-wire ST	✓	✓							CC03	
AI 4xI 2-wire 4...20mA HART	✓	✓							CC03	
AQ 2xU ST	✓	✓							CC00	
AQ 2xI ST	✓	✓							CC00	
AQ 4xU/I ST	✓	✓							CC00	
AQ 2xU/I HS	✓	✓							CC00	

1.1 Possible combinations of BaseUnits and I/O modules

I/O module	BaseUnit BU15-		BaseUnit BU20-						Color-coded label for process terminals	
	BU type A0 P16+A10+2D P16+A0+2D P16+A10+2B P16+A0+2B	BU type A1 P16+A0+12D/T P16+A0+2D/T P16+A0+12B/T P16+A0+2B/T	BU type B0 P12+A4+0B	BU type B1 P12+A0+4B	BU type C0 P6+A2+4D	BU type C1 P6+A2+4B	BU type D0 P12+A0+0B	BU type F0 P8+A4+0B		
AQ 2xU/I HF	✓	✓							CC00	
AI Energy Meter 400VAC ST							✓		---	---
AI Energy Meter 480VAC ST							✓		---	---
Fail-safe modules										
F-PM-E 24VDC/8A PPM ST					✓				CC52	
F-DI 8x24VDC HF	✓								CC01	
F-DQ 4x24VDC/2A PM HF	✓								CC02	
F-RQ 1x24VDC/24..230 VAC/5A							✓		CC42	
Communication modules										
CM 4xIO-Link	✓								CC04	
CM AS-i Master ST					✓				---	---
F-CM AS-i Safety ST					✓	✓			---	---
CM PtP	✓								---	---
Technology modules										
TM Count 1x24V	✓								---	---
TM PosInput 1	✓								---	---
TM Timer DIDQ 10x24V	✓								---	---
TM Pulse 2x24V				✓					---	---
SIWAREX WP321	✓								---	---

Table 1- 2 Possible combinations of BaseUnits and motor starters

Motor starters	BaseUnit BU30-				Color-coded label for process terminals
	MS1 with infeed 24 V DC and 500 V AC	MS2 with infeed 500 V AC	MS3 with infeed 24 V DC	MS4 without infeed	
Direct starter					
DS 0.3 - 1 A		✓			---
DS 0.9 - 3 A		✓			---
DS 2.8 - 9 A		✓			---
Reversing starter					
RS 0.3 - 1 A		✓			---
RS 0.9 - 3 A		✓			---
RS 2.8 - 9 A		✓			---

1.2 CPUs

CPUs

CPU	Number in pack	Article number
CPU 1510SP-1 PN with server module	Pack of 1	6ES7510-1DJ0x-0AB0
CPU 1510SP F-1 PN with server module	Pack of 1	6ES7510-1SJ0x-0AB0
CPU 1512SP-1 PN with server module	Pack of 1	6ES7512-1DK0x-0AB0
CPU 1512SP F-1 PN with server module	Pack of 1	6ES7512-1SK0x-0AB0
CPU 1515SP PC with server module	Pack of 1	6ES7677-2AAxx-0xx0

Important differences between CPUs...PN				
Features	CPU 1510SP-1 PN	CPU 1510SP F-1 PN	CPU 1512SP-1 PN	CPU 1512SP F-1 PN
Bus connection	PROFINET: BusAdapter (port 1, 2) <ul style="list-style-type: none"> • BA 2xRJ45 (as of firmware version 1.6) • BA 2xFC (as of firmware version V1.6) RJ45, integrated (port 3)		PROFINET: BusAdapter (port 1, 2) <ul style="list-style-type: none"> • BA 2xRJ45 (as of firmware version 1.6) • BA 2xFC (as of firmware version V1.6) • BA 2xSCRJ (as of firmware V1.8)¹ • BA SCRJ/RJ45 (as of firmware V1.8)¹ • BA SCRJ/FC (as of firmware V1.8)¹ • BA 2xLC (as of firmware V2.0)¹ • BA LC/RJ45 (as of firmware V2.0)¹ • BA LC/FC (as of firmware V2.0)¹ RJ45, integrated (port 3)	
	PROFIBUS: PROFIBUS DP connection socket via CM DP communication module			
Number of modules	64			
Data work memory	750 KB	750 KB	1 MB	1 MB
Code work memory	100 KB	150 KB	200 KB	300 KB
Address space	1280 bytes/2560 bytes ²			
Multi hot-swapping	Yes			
Can be used for safety applications (supports PROFIsafe V2.0)	No	Yes	No	Yes

¹ Only with article numbers 6ES7512-1DK01-0AB0 and 6ES7512-1SK01-0AB0

² Only 6ES7510-1DJ01-0AB0, 6ES7512-1SJ01-0AB0, 6ES7512-1DK01-0AB0 and 6ES7512-1SK01-0AB0 with FW version V2.0

Note

The CM AS-i Master ST and F-CM AS-i Safety ST communication modules are supported as of firmware V1.8 of the CPUs. Note the following additional requirements:

CM AS-i Master ST:

- Firmware version of the CM AS-i Master ST: V1.1
- STEP 7 (TIA Portal): V13 SP1 Update 4 or higher

F-CM AS-i Safety ST

- Firmware version of the CM AS-i Safety ST: V1.0
- STEP 7 (TIA Portal): as of V13 SP1 Update 4 and HSP0070 V3.0

1.3 Interface modules

Interface modules

Interface modules	Number in pack	Article number
Interface module IM 155-6 PN BA	Pack of 1	6ES7155-6AR00-0AN0
Interface module IM 155-6 PN ST		
• with BusAdapter BA 2xRJ45 and server module	Pack of 1	6ES7155-6AA00-0BN0
• with server module	Pack of 1	6ES7155-6AU00-0BN0
Interface module IM 155-6 PN HF with server module	Pack of 1	6ES7155-6AU00-0CN0
Interface module IM 155-6 PN HS with server module	Pack of 1	6ES7155-6AU00-0DN0
Interface module IM 155-6 DP HF with PROFIBUS FastConnect bus connector (6ES7972-0BB70-0XA0) and server module	Pack of 1	6ES7155-6BA00-0CN0

Important differences between the interface modules					
Features	IM 155-6 PN BA	IM 155-6 PN ST	IM 155-6 PN HF	IM 155-6 PN HS	IM 155-6 DP HF
Bus connection	PROFINET: 2xRJ45, integrated	PROFINET: BusAdapter <ul style="list-style-type: none"> BA 2xRJ45 (as of firmware V1.0) BA 2xFC (as of firmware V1.0) 	PROFINET: BusAdapter <ul style="list-style-type: none"> BA 2xRJ45 (as of firmware V2.0) BA 2xFC (as of firmware V2.0) BA 2xSCRJ (as of firmware V2.2) BA SCRJ/RJ45 (as of firmware V3.1) BA SCRJ/FC (as of firmware V3.1) BA 2xLC (as of firmware V3.3) BA LC/RJ45 (as of firmware V3.3) BA LC/FC (as of firmware V3.3) 	PROFINET: BusAdapter <ul style="list-style-type: none"> BA 2xRJ45 (as of firmware V4.0) BA 2xFC (as of firmware V4.0) BA 2xSCRJ (as of firmware V4.0) BA SCRJ/RJ45 (as of firmware V4.0) BA SCRJ/FC (as of firmware V4.0) BA 2xLC (as of firmware V4.0) BA LC/RJ45 (as of firmware V4.0) BA LC/FC (as of firmware V4.0) 	PROFIBUS: PROFIBUS DP connection socket
Number of modules	12	32	64	30	32
RESET button	No	Yes	Yes	Yes	Not necessary
Address space (I/O data)	32 bytes	798 bytes	1440 bytes	968 bytes	244 bytes
Multi hot-swapping	No	No	Yes	Yes	Yes

1.4 BaseUnits

Table 1- 3 Station expansion via ET-Connection (mixed configuration ET 200SP/ET 200AL)

Modules	Number in pack	Article number
BU-Send	Pack of 1	6ES7193-6BN00-0NE0
BA-Send 1xFC	Pack of 1	6ES7193-6AS00-0AA0

1.4 BaseUnits

BaseUnits

Table 1- 4 BaseUnits for I/O modules

BU type	BaseUnits (short name)	Color-coded labels*	Packaging unit	Article number
A0	BU15-P16+A10+2D	P16: CC00 to CC05 A10: CC71 to CC73	Pack of 1	6ES7193-6BP20-0DA0
			Pack of 10	6ES7193-6BP20-2DA0
A0	BU15-P16+A0+2D	P16: CC00 to CC05	Pack of 1	6ES7193-6BP00-0DA0
			Pack of 10	6ES7193-6BP00-2DA0
A0	BU15-P16+A10+2B	P16: CC00 to CC05 A10: CC71 to CC73	Pack of 1	6ES7193-6BP20-0BA0
			Pack of 10	6ES7193-6BP20-2BA0
A0	BU15-P16+A0+2B	P16: CC00 to CC05	Pack of 1	6ES7193-6BP00-0BA0
			Pack of 10	6ES7193-6BP00-2BA0
A1	BU15-P16+A0+12D/T	P16: CC00 to CC05 12D: CC74	Pack of 1	6ES7193-6BP40-0DA1
A1	BU15-P16+A0+2D/T	P16: CC00 to CC05	Pack of 1	6ES7193-6BP00-0DA1
A1	BU15-P16+A0+12B/T	P16: CC00 to CC05 12B: CC74	Pack of 1	6ES7193-6BP40-0BA1
A1	BU15-P16+A0+2B/T	P16: CC00 to CC05	Pack of 1	6ES7193-6BP00-0BA1
B0	BU20-P12+A4+0B	A4: CC81 to CC83	Pack of 1	6ES7193-6BP20-0BB0
			Pack of 10	6ES7193-6BP20-2BB0
B1	BU20-P12+A0+4B	P12: CC41	Pack of 1	6ES7193-6BP20-0BB1
C0	BU20-P6+A2+4D	P6: CC51, CC52 A2: CC84 to CC86	Pack of 1	6ES7193-6BP20-0DC0
C1	BU20-P6+A2+4B	P6: CC51 A2: CC84 to CC86	Pack of 1	6ES7193-6BP20-0BC1
D0	BU20-P12+A0+0B	---	Pack of 1	6ES7193-6BP00-0BD0
F0	BU20-P8+A4+0B	P8: CC42	Pack of 1	6ES7193-6BP20-0BF0

* not shipped with the BaseUnit

Table 1- 5 BaseUnits for motor starters

BU type	BaseUnits (short name)	Color-coded labels	Packaging unit	Article number
MS1	BU30-MS1	---	Pack of 1	3RK1908-0AP00-0AP0
MS2	BU30-MS2	---	Pack of 1	3RK1908-0AP00-0CP0
MS3	BU30-MS3	---	Pack of 1	3RK1908-0AP00-0BP0
MS4	BU30-MS4	---	Pack of 1	3RK1908-0AP00-0DP0

1.5 I/O modules

I/O modules

Digital I/O modules	Number in pack	Article number
DI 16x24VDC ST	Pack of 1	6ES7131-6BH00-0BA0
	Pack of 10	6ES7131-6BH00-2BA0
DI 8x24VDC ST	Pack of 1	6ES7131-6BF00-0BA0
	Pack of 10	6ES7131-6BF00-2BA0
DI 8x24VDC HF	Pack of 1	6ES7131-6BF00-0CA0
DI 8x24VDC HS	Pack of 1	6ES7131-6BF00-0DA0
DI 8xNAMUR HF	Pack of 1	6ES7131-6TF00-0CA0
DI 8x24VDC BA	Pack of 1	6ES7131-6BF00-0AA0
	Pack of 10	6ES7131-6BF00-2AA0
DI 8x24VDC SRC BA	Pack of 1	6ES7131-6BF60-0AA0
DI 4x120..230VAC ST	Pack of 1	6ES7131-6FD00-0BB1
DQ 16x24VDC/0.5A ST	Pack of 1	6ES7132-6BH00-0BA0
	Pack of 10	6ES7132-6BH00-2BA0
DQ 8x24VDC/0.5A ST	Pack of 1	6ES7132-6BF00-0BA0
	Pack of 10	6ES7132-6BF00-2BA0
DQ 8x24VDC/0.5A HF	Pack of 1	6ES7132-6BF00-0CA0
DQ 8x24VDC/0.5A BA	Pack of 1	6ES7132-6BF00-0AA0
	Pack of 10	6ES7132-6BF00-2AA0
DQ 8x24VDC/0.5A SNK BA	Pack of 1	6ES7132-6BF60-0AA0
DQ 4x24VDC/2A ST	Pack of 1	6ES7132-6BD20-0BA0
	Pack of 10	6ES7132-6BD20-2BA0
DQ 4x24..230VAC/2A ST	Pack of 1	6ES7132-6FD00-0BB1
	Pack of 10	6ES7132-6FD00-2BB1
DQ 4x24VDC/2A HF	Pack of 1	6ES7132-6BD20-0CA0
DQ 4x24VDC/2A HS	Pack of 1	6ES7132-6BD20-0DA0
RQ 4x24VUC/2A CO ST	Pack of 1	6ES7132-6GD50-0BA0
RQ 4x120VDC-230VAC/5A NO ST	Pack of 1	6ES7132-6HD00-0BB1
	Pack of 10	6ES7132-6HD00-2BB1
RQ 4x120VDC-230VAC/5A NO MA ST	Pack of 1	6ES7132-6MD00-0BB1

1.5 I/O modules

Analog I/O modules	Number in pack	Article number
AI 8xU BA	Pack of 1	6ES7134-6FF00-0AA1
AI 2xU ST	Pack of 1	6ES7134-6FB00-0BA1
AI 4xU/I 2-wire ST	Pack of 1	6ES7134-6HD00-0BA1
	Pack of 10	6ES7134-6HD00-2BA1
AI 2xU/I 2-/4-wire HF	Pack of 1	6ES7134-6HB00-0CA1
AI 2xU/I 2-/4-wire HS	Pack of 1	6ES7134-6HB00-0DA1
AI 8xI 2-/4-wire BA	Pack of 1	6ES7134-6GF00-0AA1
AI 2xI 2-/4-wire ST	Pack of 1	6ES7134-6GB00-0BA1
AI 4xI 2-/4-wire ST	Pack of 1	6ES7134-6GD00-0BA1
AI 8xRTD/TC 2-wire HF	Pack of 1	6ES7134-6JF00-0CA1
	Pack of 10	6ES7134-6JF00-2CA1
AI 4xRTD/TC 2-/3-/4-wire HF	Pack of 1	6ES7134-6JD00-0CA1
	Pack of 10	6ES7134-6JD00-2CA1
AI 4xI 2-wire 4...20mA HART	Pack of 1	6ES7134-6TD00-0CA1
AQ 2xU ST	Pack of 1	6ES7135-6FB00-0BA1
AQ 2xI ST	Pack of 1	6ES7135-6GB00-0BA1
AQ 4xU/I ST	Pack of 1	6ES7135-6HD00-0BA1
AQ 2xU/I HF	Pack of 1	6ES7135-6HB00-0CA1
AQ 2xU/I HS	Pack of 1	6ES7135-6HB00-0DA1
AI Energy Meter 400VAC ST	Pack of 1	6ES7134-6PA01-0BD0
AI Energy Meter 480VAC ST	Pack of 1	6ES7134-6PA20-0BD0

Fail-safe modules	Number in pack	Article number
F-PM-E 24VDC/8A PPM ST	Pack of 1	6ES7136-6PA00-0BC0
F-DI 8x24VDC HF	Pack of 1	6ES7136-6BA00-0CA0
F-DQ 4x24VDC/2A PM HF	Pack of 1	6ES7136-6DB00-0CA0
F-RQ 1x24VDC/24..230VAC/5A	Pack of 1	6ES7136-6RA00-0BF0

Communication modules	Number in pack	Article number
CM 4xIO-Link	Pack of 1	6ES7137-6BD00-0BA0
CM AS-i Master ST	Pack of 1	3RK7137-6SA00-0BC1
F-CM AS-i Safety ST	Pack of 1	3RK7136-6SC00-0BC1
CM PtP	Pack of 1	6ES7137-6AA00-0BA0
CM DP (for CPU)	Pack of 1	6ES7545-5DA00-0AB0

Technology module	Number in pack	Article number
TM Count 1x24V	Pack of 1	6ES7138-6AA00-0BA0
TM PosInput 1	Pack of 1	6ES7138-6BA00-0BA0
TM Timer DIDQ 10x24V	Pack of 1	6ES7138-6CG00-0BA0

Technology module	Number in pack	Article number
TM Pulse 2x24V	Pack of 1	6ES7138-6DB00-0BB1
SIWAREX WP321	Pack of 1	7MH4138-6AA00-0BA0

1.6 Motor starters

Motor starters

Direct starter	Packaging unit	Article number
DS 0.3 - 1 A	Pack of 1	3RK1308-0AB00-0CP0
DS 0.9 - 3 A	Pack of 1	3RK1308-0AC00-0CP0
DS 2.8 - 9 A	Pack of 1	3RK1308-0AD00-0CP0

Reversing starter	Packaging unit	Article number
RS 0.3 - 1 A	Pack of 1	3RK1308-0BB00-0CP0
RS 0.9 - 3 A	Pack of 1	3RK1308-0BC00-0CP0
RS 2.8 - 9 A	Pack of 1	3RK1308-0BD00-0CP0











1.7 Accessories

Accessories











General accessories	Packaging unit	Article number
BusAdapter		
<ul style="list-style-type: none"> BA 2xRJ45 (PROFINET BusAdapter with standard Ethernet socket) 	Pack of 1	6ES7193-6AR00-0AA0
<ul style="list-style-type: none"> BA 2xFC (PROFINET BusAdapter with FastConnect Ethernet connection) 	Pack of 1	6ES7193-6AF00-0AA0
<ul style="list-style-type: none"> BA 2xSCRJ (PROFINET BusAdapter with POF/PCF fiber-optic cable connection) 	Pack of 1	6ES7193-6AP00-0AA0
<ul style="list-style-type: none"> BA SCRJ/RJ45 (media converter, PROFINET BusAdapter with fiber-optic cable FOC ⇔ standard RJ45 connector) 	Pack of 1	6ES7193-6AP20-0AA0
<ul style="list-style-type: none"> BA SCRJ/FC (media converter, PROFINET BusAdapter with fiber-optic cable FOC ⇔ direct connection of bus cable) 	Pack of 1	6ES7193-6AP40-0AA0
<ul style="list-style-type: none"> BA 2xLC (PROFINET BusAdapter with glass fiber-optic cable connection) 	Pack of 1	6ES7193-6AG00-0AA0

1.7 Accessories

General accessories	Packaging unit	Article number
<ul style="list-style-type: none"> BA LC/RJ45 (media converter, PROFINET BusAdapter with glass fiber-optic cable ↔ standard RJ45 connector) 	Pack of 1	6ES7193-6AG20-0AA0
<ul style="list-style-type: none"> BA LC/FC (media converter, PROFINET BusAdapter with glass fiber-optic cable ↔ direct connection of bus cable) 	Pack of 1	6ES7193-6AG40-0AA0
PROFIBUS FastConnect bus connector	Pack of 1	6ES7972-0BB70-0XA0
Server module (spare part)	Pack of 1	6ES7193-6PA00-0AA0
BU cover		
<ul style="list-style-type: none"> 15 mm wide 	Pack of 5	6ES7133-6CV15-1AM0
<ul style="list-style-type: none"> 20 mm wide 	Pack of 5	6ES7133-6CV20-1AM0
Shield connector for BaseUnit (shield contacts and shield terminals)	Pack of 5	6ES7193-6SC00-1AM0
Reference identification label, sheet with 16 labels	Pack of 10	6ES7193-6LF30-0AW0
Labeling strips (for labeling the I/O modules)		
<ul style="list-style-type: none"> Roll, light gray (with a total of 500 labeling strips) 	Pack of 1	6ES7193-6LR10-0AA0
<ul style="list-style-type: none"> Roll, yellow (with a total of 500 labeling strips) 	Pack of 1	6ES7193-6LR10-0AG0
<ul style="list-style-type: none"> DIN A4 sheets, light gray (with a total of 1000 labeling strips) 	Pack of 10	6ES7193-6LA10-0AA0
<ul style="list-style-type: none"> DIN A4 sheets, yellow (with a total of 1000 labeling strips) 	Pack of 10	6ES7193-6LA10-0AG0
Mounting rails, tin-plated steel strip		
<ul style="list-style-type: none"> Length: 483 mm 	Pack of 1	6ES5710-8MA11
<ul style="list-style-type: none"> Length: 530 mm 	Pack of 1	6ES5710-8MA21
<ul style="list-style-type: none"> Length: 830 mm 	Pack of 1	6ES5710-8MA31
<ul style="list-style-type: none"> Length: 2000 mm 	Pack of 1	6ES5710-8MA41

Accessories color-coded labels (push-in terminals), 15 mm wide	Packaging unit		Article number
16 process terminals (see manual for I/O module)			
<ul style="list-style-type: none"> Gray (terminals 1 to 16); color code CC00 	Pack of 10		6ES7193-6CP00-2MA0
<ul style="list-style-type: none"> Gray (terminals 1 to 8), red (terminals 9 to 16); color code CC01 	Pack of 10		6ES7193-6CP01-2MA0
<ul style="list-style-type: none"> Gray (terminals 1 to 8), blue (terminals 9 to 16); color code CC02 	Pack of 10		6ES7193-6CP02-2MA0
<ul style="list-style-type: none"> Gray (terminals 1 to 8), red (terminals 9 to 12), gray (terminals 13 to 16); color code CC03 	Pack of 10		6ES7193-6CP03-2MA0
<ul style="list-style-type: none"> Gray (terminals 1 to 8), red (terminals 9 to 12), blue (terminals 13 to 16); color code CC04 	Pack of 10		6ES7193-6CP04-2MA0
<ul style="list-style-type: none"> Gray (terminals 1 to 12), red (terminals 13 and 14), blue (terminals 15 and 16); color code CC05 	Pack of 10		6ES7193-6CP05-2MA0
10 AUX terminals (for BU15-P16+A10+2D, BU15-P16+A10+2B)			
<ul style="list-style-type: none"> Yellow-green (terminals 1A to 10A); color code CC71 	Pack of 10		6ES7193-6CP71-2AA0
<ul style="list-style-type: none"> Red (terminals 1A to 10A); color code CC72 	Pack of 10		6ES7193-6CP72-2AA0
<ul style="list-style-type: none"> Blue (terminals 1A to 10A); color code CC73 	Pack of 10		6ES7193-6CP73-2AA0
10 add-on terminals (for BU15-P16+A0+12D/T, BU15-P16+A0+12B/T)			
<ul style="list-style-type: none"> Red (terminals 1B to 5B), blue (terminals 1C to 5C); color code CC74 	Pack of 10		6ES7193-6CP74-2AA0

1.7 Accessories

Accessories color-coded labels (push-in terminals), 20 mm wide	Packaging unit	Article number	
12 process terminals (see manual for I/O module)			
<ul style="list-style-type: none"> Gray (terminals 1 to 4), red (terminals 5 to 8), blue (terminals 9 to 12); color code CC41 	Pack of 10		6ES7193-6CP41-2MB0
<ul style="list-style-type: none"> Gray (terminals 1 to 8), red (terminals 9 and 10), blue (terminals 11 and 12), color code CC42 	Pack of 10		6ES7193-6CP42-2MB0
6 process terminals (see manual for I/O module)			
<ul style="list-style-type: none"> Gray (terminals 1 to 4), red (terminal 5), blue (terminal 6); color code CC51 	Pack of 10		6ES7193-6CP51-2MC0
<ul style="list-style-type: none"> Gray (terminals 1, 2 and 5), red (terminals 3 and 4), blue (terminal 6); color code CC52 	Pack of 10		6ES7193-6CP52-2MC0
4 AUX terminals (for BU20-P12+A4+0B)			
<ul style="list-style-type: none"> Yellow-green (terminals 1A to 4A); color code CC81 	Pack of 10		6ES7193-6CP81-2AB0
<ul style="list-style-type: none"> Red (terminals 1A to 4A); color code CC82 	Pack of 10		6ES7193-6CP82-2AB0
<ul style="list-style-type: none"> Blue (terminals 1A to 4A); color code CC83 	Pack of 10		6ES7193-6CP83-2AB0
2 AUX terminals (for BU20-P6+A2+4D, BU20-P6+A2+4B)			
<ul style="list-style-type: none"> Yellow-green (terminals 1A and 2A); color code CC84 	Pack of 10		6ES7193-6CP84-2AC0
<ul style="list-style-type: none"> Red (terminals 1A and 2A); color code CC85 	Pack of 10		6ES7193-6CP85-2AC0
<ul style="list-style-type: none"> Blue (terminals 1A and 2A); color code CC86 	Pack of 10		6ES7193-6CP86-2AC0

Accessories for motor starter	Packaging unit	Article number
3DI / LC module	Pack of 1	3RK1908-1AA00-0BP0
Fan	Pack of 1	3RW4928-8VB00
Additional mechanical bracket for BaseUnit	Pack of 1	3RK1908-1EA00-1BP0
Cover for an empty BaseUnit	Pack of 1	3RK1908-1CA00-0BP0
Touch protection cover for infeed bus	Pack of 1	3RK1908-1DA00-2BP0

Supplements to ET 200SP documentation

2.1 System manual

System manual ET 200SP Distributed I/O system, Edition 12/2015

Section 14.1 Standards and approvals

CE marking



The ET 200SP distributed I/O system meets the requirements and protection targets of the following directives and complies with the harmonized European standards (EN) for programmable logic controllers published in the official gazettes of the European Community:

- 2014/35/EU "Electrical equipment designed for use within certain voltage limits" (Low-Voltage Directive)
- 2014/30/EU "Electromagnetic Compatibility" (EMC directive)
- 2014/34/EU "Equipment and protective systems for use in hazardous areas" (Explosion protection directive)
- The following also applies to ET 200SP F-modules: 2006/42/EC "Machinery Directive"

The EC declarations of conformity are available to the responsible authorities from:

Siemens AG
Digital Factory

Factory Automation
DF FA AS DH AMB
Postfach 1963
D-92209 Amberg

These files are also available for download on the Siemens Industry Online Support Web pages, under the keyword "Declaration of Conformity".

2.2 CPU manuals

Manual CPU 1512SP-1 PN, Edition 09/2016

Section 4.1 Status and error display of the CPU

MT1/MT2 LEDs on BusAdapter BA 2xSCRJ, BA SCRJ/RJ45, BA SCRJ/FC

Table 2- 1 Status and error displays of MT1/MT2 LEDs

LED	Meaning	Solution
MT1/MT2*		
□ Off	No error	---
■ On	<ul style="list-style-type: none"> Fiber-optic error Maintenance demanded: Attenuation through the fiber-optic cable is so high that operation will soon no longer be possible. 	Causes and measures for the transmission route: <ul style="list-style-type: none"> Replacement of fiber-optic cable if damaged or aged Correct installation of the PROFINET connector/PROFINET connections Adherence to maximum length of 50 m for POF cable or 100 m for PCF cable Secure fit of the FOC connector.

* Only available on BusAdapter BA 2xSCRJ

Section 6 Technical specifications

Technical specifications of the BusAdapters BA 2xSCRJ, BA SCRJ/RJ45, BA SCRJ/FC

The maximum length of the PCF-GI fiber-optic cable is 250 m.

2.3 Interface module manuals

Configuration notes on interface modules depending on the I/O modules

Module	Firm-ware version	IM 155-6 PN BA	IM 155-6 PN ST				IM 155-6 PN HF						IM 155-6 PNH S	IM 155-DP HF			
		V3.2	V1.0	V1.1	V3.1	V3.3	V2.0	V2.1	V2.2	V3.0	V3.1	V3.3	V4.0	V1.0	V1.1	V3.0	V3.1
AI 2xI 2-/4-wire ST	V1.0	✓	---	---	✓	✓	---	---	---	✓	✓	✓	✓	---	---	✓	✓
AI 2xU ST	V1.0	✓	---	---	✓	✓	---	---	---	✓	✓	✓	✓	---	---	✓	✓
AI 2xU/I 2-/4-wire HF	V2.0	✓	✓	✓	✓	✓	✓	✓	✓	✓	✓	✓	✓	✓	✓	✓	✓
AI 8xI 2-/4-wire BA	V1.0	✓	---	✓	✓	✓	---	---	✓	✓	✓	✓	✓	---	✓	✓	✓
AI 8xU BA	V1.0	✓	---	✓	✓	✓	---	---	✓	✓	✓	✓	✓	---	✓	✓	✓
AI Energy Meter 400VAC ST	V3.0	✓	✓	✓	✓	✓	✓	✓	✓	✓	✓	✓	✓	✓	✓	✓	✓
AI Energy Meter 480VAC ST	V4.0	✓	---	---	✓	✓	---	---	---	✓	✓	✓	✓	---	---	✓	✓
AQ 2xI ST	V1.0	✓	---	---	✓	✓	---	---	---	✓	✓	✓	✓	---	---	✓	✓
AQ 2xU ST	V1.0	✓	---	---	✓	✓	---	---	---	✓	✓	✓	✓	---	---	✓	✓
DI 8x24VDC BA	V1.0	✓	---	✓	✓	✓	---	---	✓	✓	✓	✓	✓	---	✓	✓	✓
DI 8x24VDC HS	V1.0	✓	---	✓	✓	✓	---	---	✓	✓	✓	✓	✓	---	✓	✓	✓
DI 8x24VDC HF	V2.0	✓	✓	✓	✓	✓	✓	✓	✓	✓	✓	✓	✓	✓	✓	✓	✓
DI 16x24VDC ST	V1.1	✓	✓	✓	✓	✓	✓	✓	✓	✓	✓	✓	✓	✓	✓	✓	✓
DQ 4x24VDC/2A HS	V1.0	✓	---	✓	✓	✓	---	---	✓	✓	✓	✓	✓	---	✓	✓	✓
DQ 4x24VDC/2A HF	V2.0	✓	✓	✓	✓	✓	✓	✓	✓	✓	✓	✓	✓	✓	✓	✓	✓
RQ 4x120VDC-230VAC/5A NO MA ST	V1.0	✓	---	---	✓	✓	---	---	---	✓	✓	✓	✓	---	---	✓	✓
DQ 8x24VDC/0.5A HF	V2.0	✓	✓	✓	✓	✓	✓	✓	✓	✓	✓	✓	✓	✓	✓	✓	✓
DQ 8x24VDC/0.5A BA	V1.0	✓	---	---	✓	✓	---	---	---	✓	✓	✓	✓	---	---	✓	✓
DQ 16x24VDC/0.5A ST	V1.1	✓	✓	✓	✓	✓	✓	✓	✓	✓	✓	✓	✓	✓	✓	✓	✓

--- This combination is not permitted in the configuration

IM 155-6 PN ST manual, Edition 12/2015

Section 3.1 Pin assignment

PROFINET interface X1 Port 2:

If autonegotiation is disabled, the RJ-45 socket (X1 Port 2) has the switch assignment (MDI-X).

Response times

The response time of the IM 155-6 PN ST is made up of:

- Backplane bus cycle time and
- Operating system processing

Note

Validity of the formula

The following formula applies to the ET 200SP backplane bus.

The following formula does not apply to the ET-Connection bus.

Backplane bus cycle time

The backplane bus cycle time is the time the interface module requires to output new output data, read new input data and then copy the data to the PROFINET send buffer.

The backplane bus cycle time is the result of the update time configured for the interface module as IO device and is at least 1 ms.

- If the configured update time ≥ 1 ms, the backplane bus cycle time is equal to the configured update time.
- If the configured update time < 1 ms, the backplane bus cycle time is the product of an integer multiple of the configured update time.

Table 2- 2 Example calculation

Configured update time	Backplane bus cycle time (integer multiple, minimum 1 ms)
250 μ s	4 x 250 μ s = 1000 μ s
750 μ s	2 x 750 μ s = 1500 μ s
1000 μ s	1000 μ s
2000 μ s	2000 μ s

Operating system processing time

The operating system processing time is calculated based on the following formula:

Operating system processing time output

$$\text{Operating system processing time_output}[\mu\text{s}] = 147 + 3.775 \text{ number_m} + 0.275 \text{ bytes_out}$$

Operating system processing time input

Operating system processing time_input[μ s] = 158.3 + 2.325 number_m + 0.325 bytes_in

Explanation of the parameters:

Number_m: Total number of all modules (incl. server module)

Bytes_out: Sum of all output bytes

Bytes_in: Sum of all input bytes

Calculating the response time**Response time output**

The response time output of the IM 155-6 PN ST is made up of:

- Backplane bus cycle time and
- Operating system processing time_output.

Response time input

The response time input of the IM 155-6 PN ST is made up of:

- Backplane bus cycle time and
- Operating system processing time_input.

IM 155-6 PN HF manual, Edition 12/2015**Section 3.1 Pin assignment**

PROFINET interface X1 Port 2:

If autonegotiation is disabled, the RJ-45 socket (X1 Port 2) has the switch assignment (MDI-X).

Section 8 Technical specifications

- Technical specifications of the BusAdapters BA 2xSCRJ, BA SCRJ/RJ45, BA SCRJ/FC:
The maximum length of the PCF-GI fiber-optic cable is 250 m.
- Technical specifications of the BusAdapters BA 2xLC, BA LC/RJ45, BA LC/FC:
Cable length:
 - Multimode graded index fiber 50/125 μ m: 3 km
 - Multimode graded index fiber 62.5/125 μ m: 3 km

IM 155-6 PN HS manual, Edition 09/2016

Section 3.1 Pin assignment

PROFINET interface X1 Port 2:

If autonegotiation is disabled, the RJ-45 socket (X1 Port 2) has the switch assignment (MDI-X).

Section 8 Technical specifications

- PROFINET certification of network class 3 is in preparation.
- Technical specifications of the BusAdapters BA 2×SCRJ, BA SCRJ/RJ45, BA SCRJ/FC: The maximum length of the PCF-GI fiber-optic cable is 250 m.

2.4 I/O module manuals

**Configuration notes on the I/O modules
(supplement to Product overview section in the manual)**

I/O module		Order number	Firmware version	STEP 7 (TIA Portal)	STEP 7 V5.5 SP3
Digital input modules	DI 16x24VDC ST	6ES7131-6BH00-0BA0	V1.1.0	HSP0162 V13 SP1 or higher	HSP0229 V6.0
	DI 8x24VDC BA	6ES7131-6BF00-0AA0	V1.0.0	HSP0126	HSP0229 V5.0
	DI 8x24VDC ST	6ES7131-6BF00-0BA0	V1.1.0	V13 Update 3	HSP0229 V4.0
	DI 8x24VDC HF	6ES7131-6BF00-0CA0	V2.0.0	HSP0163 V13 SP1 Update 4 or higher	HSP0229 V6.0
	DI 8x24VDC HS	6ES7131-6BF00-0DA0	V1.0.2	Integrated as of V14	HSP0229 V5.0

I/O module		Order number	Firmware version	STEP 7 (TIA Portal)	STEP 7 V5.5 SP3
Digital output modules	DQ 8x24VDC/0.5A BA	6ES7132-6BF00-0AA1	V1.0.0	HSP0162 V13 SP1 or higher	HSP0230 V6.0
	DQ 4x24VDC/2A ST	6ES7132-6BD20-0BA0	V1.1.0	V13 Update 3	HSP0230 V4.0
	DQ 8x24VDC/0.5A ST	6ES7132-6BF00-0BA0	V1.1.0	V13 Update 3	HSP0230 V4.0
	DQ 16x24VDC/0.5A ST	6ES7132-6BH00-0BA0	V1.1.0	HSP0162 V13 SP1 or higher	HSP0230 V6.0
	DQ 8x24VDC/0.5A HF	6ES7132-6BF00-0CA0	V2.0.0	HSP0163 V13 SP1 Update 4 or higher	HSP0230 V6.0
	DQ 4x24VDC/2A HF	6ES7132-6BD20-0CA0	V2.0.0	HSP0163 V13 SP1 Update 4 or higher	HSP0230 V6.0
	DQ 4x24VDC/2A HS	6ES7132-6BD20-0DA0	V1.0.2	Integrated as of V14	HSP0230 V5.0
	RQ 4x120VDC-230VAC/5A NO ST	6ES7132-6HD00-0BB1	V1.0.0	HSP0128	HSP0232 V5.0
	RQ 4x120VDC-230VAC/5A NO MA ST	6ES7132-6MD00-0BB1	V1.0.0	HSP0162 V13 SP1 or higher	HSP0232 V6.0
Analog input modules	AI 8xI BA	6ES7134-6FF00-0AA1	V1.0.0	HSP0126	HSP0227 V5.0
	AI 2xU ST	6ES7134-6FB00-0BA1	V1.0.0	HSP0160 V13 SP1 or higher	HSP0227 V6.0
	AI 8xI 2-/4-wire BA	6ES7134-6GF000AA1	V1.0.0	HSP0126	HSP0227 V5.0
	AI 4xI 2-/4-wire ST	6ES7134-6GD00-0BA1	V1.1.0	V13 Update 3	HSP0227 V4.0
	AI 2xI 2-/4-wire ST	6ES7134-6GB00-0BA1	V1.0.0	HSP0160 V13 SP1 or higher	HSP0227 V6.0
	AI 4xU/I 2-wire ST	6ES7134-6HD00-0BA1	V1.1.0	V13 Update 3	HSP0227 V4.0
	AI 2xU/I 2-/4-wire HF	6ES7134-6HB00-0CA1	V2.0.0	HSP0161 V13 SP1 or higher	HSP0227 V6.0 V5.5 SP4 HF7 or higher
	AI 2xU/I 2-/4-wire HS	6ES7134-6HB00-0DA1	V2.0.1	Integrated as of V14	HSP0227 V5.0
	AI Energy Meter 400VAC ST	6ES7134-6PA01-0BD0	V3.0.0	V13 SP1 Update 4 HSP0159	HSP0227 V6.0
	AI Energy Meter 480VAC ST	6ES7134-6PA20-0BD0	V4.0.0	V13 SP1 Update 4 HSP0159	HSP0227 V6.0 V5.5 SP4 HF7 or higher

I/O module		Order number	Firmware version	STEP 7 (TIA Portal)	STEP 7 V5.5 SP3
Analog output modules	AQ 2xU ST	6ES7135-6FB00-0BA1	V1.0.0	HSP0160 V13 SP1 or higher	HSP0228 V6.0
	AQ 2xI ST	6ES7135-6GB00-0BA1	V1.0.0	HSP0160 V13 SP1 or higher	HSP0228 V6.0
	AQ 4xU/I ST	6ES7135-6HD00-0BA1	V1.1.0	V13 Update 3	HSP0228 V4.0
	AQ 2xU/I HS	6ES7135-6HB00-0DA1	V2.0.1	Integrated as of V14	HSP0228 V5.0

2.4.1 Digital module device manuals

Manuals for I/O modules ST, BA

When you have deactivated all channels of the I/O module, a diagnostics alarm is still generated in the case of a fault if the "Missing supply voltage L+" diagnostics is enabled. For the following I/O modules, this behavior is corrected as of firmware version > V1.1.0:

- DI 16x24VDC ST
- DI 8x24VDC ST
- DQ 16x24VDC/0.5A ST
- DQ 8x24VDC/0.5 A ST
- DQ 4x24VDC/0.5A ST

Manuals for digital input modules with wire-break detection

When wire-break detection is configured the module requires a low quiescent current at the digital input in case of "0" signal for the monitoring. The parallel connection of a resistor with 25 kΩ bis 45 kΩ is required in order that this quiescent current can flow when encoder contacts are open.

If wire-break detection is disabled in the configuration, no parallel connection of the resistor is required.

If wire-break detection is configured, connect a resistor with 25 kΩ to 45 kΩ parallel to each mechanical encoder contact.

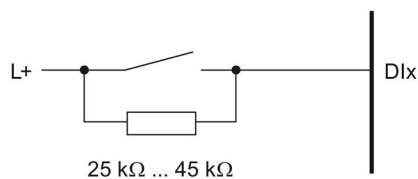

Figure 2-1 Connect mechanical encoder contact with resistor

Manuals DI 4x120...230VAC ST, Edition 02/2014; DQ 4x24...230VAC/2A ST, Edition 02/2014

Section 4.3 Address space

If you have enabled value status, the module returns value status 1, regardless of the state of the connected supply voltage.

Manual DI 8x24VDC HF, Edition 02/2014

Section 6.1 Technical specifications

- 24 V encoder supply
 - Output current, max.: 700 mA, total current

Manual DI 8xNAMUR HF, Edition 02/2014

Section A.2 Parameter assignment and structure of parameter data record

With data records 0 to 7, you can configure individual channels.

When the interface module IM 155-6 DP HF (PROFIBUS DP) is used and data records 0 and 1 are read, the module returns the diagnostics data records and not the parameter data records of the DI 8xNAMUR HF.

DQ 4x24VDC/2A HS manual, Edition 09/2016

Section 6.1 Technical specifications

For this module, the marine approval for the bridge and deck zone is valid from a bus cycle time of at least 250 μ s.

Manual DQ 4x24...230VAC/2A ST digital output module, Edition 03/2015

Section 3.1 Pin assignment

Note

Power limitation

To limit power, each input voltage must have a fuse with a maximum rating of 8 A tripping current. The fuse must be a quick-acting microfuse.

Section 6.1 Technical specifications

Short-circuit protection: No; install a fuse with 8 A tripping current when using a type B1 BU.

Overload protection: No; install a fuse with 8 A tripping current when using a type B1 BU.

The fuse must be a quick-acting microfuse in each case.

DQ 8x24VDC/0.5A ST manual, Edition 07/2014

Section 4.2 Explanation of the parameters (as of functional version FS-05 of DQ 8x24VDC/0.5A ST)

Diagnostics: Wire break:

The module responds to a wire break as follows:

- Disabled:
 - Channel status LED lit green
 - Output voltage present at channel
- Enabled:
 - Channel status LED is off
 - Output is switched off
 - In addition, the wire break diagnostics is signaled and the DIAG LED on the module flashes red

Note

If one of the two parameters "Diagnostics: Short-circuit to L+" or "Diagnostics: Wire break" is enabled and one of these diagnostics occurs, the affected channel is switched off. This prevents undefined load switching and supports detection of a faulty channel for module diagnostics.

RQ 4x24VUC/2A CO ST manual, Edition 02/2014

Section 4.3 Address space

Configuration options for the RQ 4x24VUC/2A CO ST digital output module:

The following configurations are possible:

- Configuration 1: without value status
- Configuration 2: with value status

Evaluating the value status:

An additional byte is allocated in the input address space if you enable the value status for the digital module. Each bit in this byte is assigned to a channel and returns information on the validity of the digital value (0 = incorrect value).

Address space for the RQ 4x24VUC/2A CO ST digital output module:

The following figure shows the assignment of the address space for the RQ 4x24VUC/2A CO ST with value status (Quality Information (QI)). The addresses for the value status are only available if the value status is enabled.

Assignment in the process image of the outputs (PIQ)

	7	6	5	4	3	2	1	0	
QB x	0	0	0	0					Output values at channels 0 to 3

Assignment in the process image of the inputs (PII)

	7	6	5	4	3	2	1	0	
IB x	0	0	0	0					Value status (QI) at channels 0 to 3

0: value output at channel is faulty

Figure 2-2 Address space for the RQ 4x24VUC/2A CO ST digital output module

Section 6.1 Technical specifications

Correction / additions to the technical specifications:

- Switching capacity of the contacts (DC)
 - Rated switching voltage (DC): 24 V
 - With resistive load, max.: 2 A
 - Thermal continuous current, max.: 2 A
- Switching capacity of the contacts (AC)
 - Rated switching voltage (AC): 24 V
 - With resistive load, max.: 0.5 A
 - Thermal continuous current, max.: 0.5 A

RQ 4x120VDC-230VAC/5A NO ST manual, Edition 03/2015 and RQ 4x120VDC-230VAC/5A NO MA ST manual, Edition 12/2015

Section 3.1 Wiring and block diagram

The AUX terminals of the self-assembling voltage bus can be used for the connection of the protective conductor (PE) or for voltages up to a maximum of 24 V DC.

2.4.2 Analog module device manuals

Manuals for analog input modules

Manual	Edition
AI 8xI 2-/4-wire BA	03/2015
AI 8xU BA	03/2015
AI 2xI 2-/4-wire ST	12/2015
AI 2xU ST	12/2015
AI 4xI 2-/4-wire ST	07/2014
AI 4xU/I 2-wire ST	07/2014
AI 4xI 2-wire 4...20mA HART	11/2014
AI 2xU/I 2-/4-wire HF	12/2015
AI 4xRTD/TC 2-/3-/4-wire HF	02/2014
AI 8xRTD/TC 2-wire HF	02/2014

Section 5.2 Parameters

Note

Please note that the settings in the "Interference frequency suppression" parameter have a direct effect on the cycle time of the module. The analog value is therefore also affected by additionally set filtering via the "Smoothing" parameter.

Manuals AI 4xRTD/TC 2-/3-/4-wire HF, Edition 02/2014; AI 8xRTD/TC 2-wire HF, Edition 02/2014

Section 3 Wiring

Note

When potential-free sensors are used, the M- inputs can be bridged and connected to ground/FE. This is not necessary for disabled inputs.

Section 4.1 Measurement types and measuring ranges, figure 4-1, Assignment in the process image input (PII)

Assignment in the process image input (PII) with SIMATIC S7

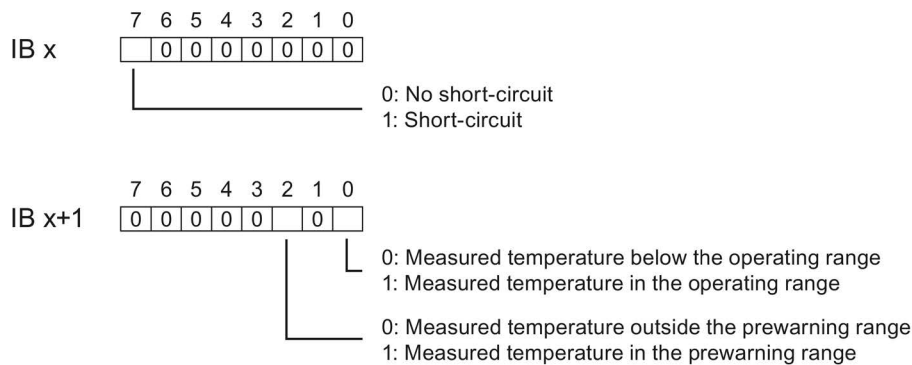

Figure 2-3 Assignment in the process image input (PII)

Manuals AI 4xRTD/TC 2-/3-/4-wire HF, Edition 02/2014; AI 8xRTD/TC 2-wire HF, Edition 02/2014; AQ 2xU/I HF, Edition 02/2014

Note

The "Channel temporarily not available" diagnostics is reported on a change to user calibration.

Other diagnostics alarms cannot be used to detect a change to user calibration.

Manuals AI 2xU/I 2-/4-wire HF, Edition 12/2015; AI Energy Meter 480VAC ST, Edition 12/2015

For configuration with STEP 7 V13 or higher (TIA Portal), real values between -7×10^{28} and $+7 \times 10^{28}$ can be input. This is true for configuration via HSP and via GSD file (PROFINET).

For configuration with STEP 7 V5.5 SP4 as of HF7, configuration by means of GSD file (PROFINET) with REAL values of -1.175×10^{38} to $+3.402 \times 10^{38}$ is possible.

With STEP 7 SP4 to HF6, parameter assignment of REAL values is not possible. Functions that require REAL values are not available in this case.

Manuals AI Energy Meter 400VAC ST, Edition 12/2015; AI Energy Meter 480VAC ST, Edition 12/2015**Requirements for the operation of the AI Energy Meter on slot 1 of the ET 200SP:**

Interface module / CPU	AI Energy Meter 400VAC ST (6ES7134-6PA01-0BD0)	AI Energy Meter 480VAC ST (6ES7134-6PA20-0BD0)
IM 155-6 PN BA (6ES7155-6AR00-0AN0)	Can be operated on slot 1 for all IM 155-6 PN BA	
IM 155-6 PN ST (6ES7155-6AU00-0BN0)	Can be operated on slot 1 for IM 155-6 PN ST from firmware version V3.1 and higher and functional status FS 07	
IM 155-6 PN HF (6ES7155-6AU00-0CN0)	Can be operated on slot 1 for IM 155-6 PN HF from firmware version V3.0 and higher and functional status FS 05	
IM 155-6 DP HF (6ES7 155-6BU00-0CN0)	Can be operated on slot 1 for IM 155-6 DP HF from firmware version V3.0 and higher	
CPU 1510SP-1 PN, CPU 1512SP-1 PN, CPU 1515SP PC	Can be operated on slot 1 for all CPUs	

Manual AI Energy Meter 480VAC ST, Edition 12/2015

Section 9 Limit monitoring

You cannot use the following measured variables for limit monitoring:

Measured value ID	Measured variables
61180	Active energy inflow L1
61181	Active energy outflow L1
61182	Reactive energy inflow L1
61183	Reactive energy outflow L1
61184	Apparent energy L1
61185	Active energy L1
61186	Reactive energy L1
61200	Active energy inflow L2
61201	Active energy outflow L2
61202	Reactive energy inflow L2
61203	Reactive energy outflow L2
61204	Apparent energy L2
61205	Active energy L2
61206	Reactive energy L2
61220	Active energy inflow L3
61221	Active energy outflow L3
61222	Reactive energy inflow L3
61223	Reactive energy outflow L3
61224	Apparent energy L3
61225	Active energy L3
61226	Reactive energy L3

If you set these IDs in the configuration of the limit monitoring (TIA Portal, STEP 7, GSD), the module reports a parameter assignment error.

Section B Measured variables

The following tables show which measured variables are available for limit monitoring or user data mapping:

Measured value ID	Measured variables	Use for	
		Limit monitoring	User data mapping
1	Voltage UL1-N	Yes	Yes
2	Voltage UL2-N	Yes	Yes
3	Voltage UL3-N	Yes	Yes
4	Voltage UL1- L2	Yes	Yes
5	Voltage UL2- L3	Yes	Yes
6	Voltage UL3- L1	Yes	Yes
7	Current L1	Yes	Yes
8	Current L2	Yes	Yes
9	Current L3	Yes	Yes

Measured value ID	Measured variables	Use for	
		Limit monitoring	User data mapping
10	Apparent power L1	Yes	Yes
11	Apparent power L2	Yes	Yes
12	Apparent power L3	Yes	Yes
13	Active power L1	Yes	Yes
14	Active power L2	Yes	Yes
15	Active power L3	Yes	Yes
16	Reactive power L1	Yes	Yes
17	Reactive power L2	Yes	Yes
18	Reactive power L3	Yes	Yes
19	Power factor L1	Yes	Yes
20	Power factor L2	Yes	Yes
21	Power factor L3	Yes	Yes
30	Frequency	Yes	Yes
34	Total active power L1L2L3	Yes	Yes
35	Total reactive power L1L2L3	Yes	Yes
36	Total apparent power L1L2L3	Yes	Yes
37	Total power factor L1L2L3	Yes	Yes
38	Amplitude unbalance for voltage	Yes	Yes
39	Amplitude unbalance for current	Yes	Yes
40	Max. voltage UL1-N	Yes	Yes
41	Max. voltage UL2-N	Yes	Yes
42	Max. voltage UL3-N	Yes	Yes
43	Max. voltage UL1- L2	Yes	Yes
44	Max. voltage UL2- L3	Yes	Yes
45	Max. voltage UL3- L1	Yes	Yes
46	Max. current L1	Yes	Yes
47	Max. current L2	Yes	Yes
48	Max. current L3	Yes	Yes
49	Max. apparent power L1	Yes	Yes
50	Max. apparent power L2	Yes	Yes
51	Max. apparent power L3	Yes	Yes
52	Max. active power L1	Yes	Yes
53	Max. active power L2	Yes	Yes
54	Max. active power L3	Yes	Yes
55	Max. reactive power L1	Yes	Yes
56	Max. reactive power L2	Yes	Yes
57	Max. reactive power L3	Yes	Yes
58	Max. power factor L1	Yes	Yes
59	Max. power factor L2	Yes	Yes
60	Max. power factor L3	Yes	Yes
61	Max. frequency	Yes	Yes
65	Max. total active power	Yes	Yes
66	Max. total reactive power	Yes	Yes
67	Max. total apparent power	Yes	Yes
68	Max. total power factor	Yes	Yes

Measured value ID	Measured variables	Use for	
		Limit monitoring	User data mapping
70	Min. voltage UL1-N	Yes	Yes
71	Min. voltage UL2-N	Yes	Yes
72	Min. voltage UL3-N	Yes	Yes
73	Min. voltage UL1- L2	Yes	Yes
74	Min. voltage UL2- L3	Yes	Yes
75	Min. voltage UL3- L1	Yes	Yes
76	Min. current L1	Yes	Yes
77	Min. current L2	Yes	Yes
78	Min. current L3	Yes	Yes
79	Min. apparent power L1	Yes	Yes
80	Min. apparent power L2	Yes	Yes
81	Min. apparent power L3	Yes	Yes
82	Min. active power L1	Yes	Yes
83	Min. active power L2	Yes	Yes
84	Min. active power L3	Yes	Yes
85	Min. reactive power L1	Yes	Yes
86	Min. reactive power L2	Yes	Yes
87	Min. reactive power L3	Yes	Yes
88	Min. power factor L1	Yes	Yes
89	Min. power factor L2	Yes	Yes
90	Min. power factor L3	Yes	Yes
91	Min. frequency	Yes	Yes
95	Min. total active power	Yes	Yes
96	Min. total reactive power	Yes	Yes
97	Min. total apparent power	Yes	Yes
98	Min. total power factor	Yes	Yes
200	Total active energy inflow L1L2L3	Yes	Yes
201	Total active energy outflow L1L2L3	Yes	Yes
202	Total reactive energy inflow L1L2L3	Yes	Yes
203	Total reactive energy outflow L1L2L3	Yes	Yes
204	Total apparent energy L1L2L3	Yes	Yes
205	Total active energy L1L2L3	Yes	Yes
206	Total reactive energy L1L2L3	Yes	Yes
210	Total active energy inflow L1L2L3	-	Yes
211	Total active energy outflow L1L2L3	-	Yes
212	Total reactive energy inflow L1L2L3	-	Yes
213	Total reactive energy outflow L1L2L3	-	Yes
214	Total apparent energy L1L2L3	-	Yes
215	Total active energy L1L2L3	-	Yes
216	Total reactive energy L1L2L3	-	Yes
61149	Neutral conductor current	Yes	Yes
61178	Phase angle L1	Yes	Yes
61180	Active energy inflow L1	-	Yes
61181	Active energy outflow L1	-	Yes
61182	Reactive energy inflow L1	-	Yes

Measured value ID	Measured variables	Use for	
		Limit monitoring	User data mapping
61183	Reactive energy outflow L1	-	Yes
61184	Apparent energy L1	-	Yes
61185	Active energy L1	-	Yes
61186	Reactive energy L1	-	Yes
61190	Overflow counter active energy inflow L1	-	Yes
61191	Overflow counter active energy outflow L1	-	Yes
61192	Overflow counter reactive energy inflow L1	-	Yes
61193	Overflow counter reactive energy outflow L1	-	Yes
61194	Overflow counter apparent energy L1	-	Yes
61198	Phase angle L2	Yes	Yes
61200	Active energy inflow L2	-	Yes
61201	Active energy outflow L2	-	Yes
61202	Reactive energy inflow L2	-	Yes
61203	Reactive energy outflow L2	-	Yes
61204	Apparent energy L2	-	Yes
61205	Active energy L2	-	Yes
61206	Reactive energy L2	-	Yes
61210	Overflow counter active energy inflow L2	-	Yes
61211	Overflow counter active energy outflow L2	-	Yes
61212	Overflow counter reactive energy inflow L2	-	Yes
61213	Overflow counter reactive energy outflow L2	-	Yes
61214	Overflow counter apparent energy L2	-	Yes
61218	Phase angle L3	Yes	Yes
61220	Active energy inflow L3	-	Yes
61221	Active energy outflow L3	-	Yes
61222	Reactive energy inflow L3	-	Yes
61223	Reactive energy outflow L3	-	Yes
61224	Apparent energy L3	-	Yes
61225	Active energy L3	-	Yes
61226	Reactive energy L3	-	Yes
61230	Overflow counter active energy inflow L3	-	Yes
61231	Overflow counter active energy outflow L3	-	Yes
61232	Overflow counter reactive energy inflow L3	-	Yes
61233	Overflow counter reactive energy outflow L3	-	Yes
61234	Overflow counter apparent energy L3	-	Yes
65500	Qualifier L1	-	Yes
65501	Qualifier L2	-	Yes
65502	Qualifier L3	-	Yes
65503	Qualifier L1L2L3	-	Yes
65504	Cumulative operating hours counters L1L2L3	Yes	Yes
65505	Operating hours counter L1	Yes	Yes
65506	Operating hours counter L2	Yes	Yes
65507	Operating hours counter L3	Yes	Yes
65510	Counter limit violation GW1	Yes	Yes
65511	Counter limit violation GW2	Yes	Yes

Measured value ID	Measured variables	Use for	
		Limit monitoring	User data mapping
65512	Counter limit violation GW3	Yes	Yes
65513	Counter limit violation GW4	Yes	Yes
65514	Counter limit violation GW5	Yes	Yes
65515	Counter limit violation GW6	Yes	Yes
65516	Counter limit violation GW7	Yes	Yes
65517	Counter limit violation GW8	Yes	Yes
65518	Counter limit violation GW9	Yes	Yes
65519	Counter limit violation GW10	Yes	Yes
65520	Counter limit violation GW11	Yes	Yes
65521	Counter limit violation GW12	Yes	Yes
65522	Counter limit violation GW13	Yes	Yes
65523	Counter limit violation GW14	Yes	Yes
65524	Counter limit violation GW15	Yes	Yes
65525	Counter limit violation GW16	Yes	Yes

In the manual for Energy Meter 480VAC ST, Edition 12/2015

In the device manual for Energy Meter 480VAC ST, the measured value ID and the associated measured variables for the complete performance are reversed. The correct association is shown in the table below:

Measured value ID	Measured variables	Unit
34	Total active power L1L2L3	W
35	Total reactive power L1L2L3	var
36	Total apparent power L1L2L3	VA
65	Max. total active power	W
66	Max. total reactive power	var
67	Max. total apparent power	VA
95	Min. total active power	W
96	Min. total reactive power	var
97	Min. total apparent power	VA

If you use the user-data mapping via data record DS 130, please note that the texts for the measured variables are also displayed incorrectly during configuration.

During configuration of the measured variables for the total active, reactive, and apparent power, select the following texts:

Desired measured variable for the user-data mapping	Text to select during configuration
Total active power L1L2L3	Total apparent power L1L2L3 (ID00034)
Total reactive power L1L2L3	Total active power L1L2L3 (ID00035)
Total apparent power L1L2L3	Total reactive power L1L2L3 (ID00036)
Max. total active power	Max. total apparent power (ID00065)
Max. total reactive power	Max. total active power (ID00066)
Max. total apparent power	Max. total reactive power (ID00067)
Min. total active power	Min. total apparent power (ID00095)
Min. total reactive power	Min. total active power (ID00096)
Min. total apparent power	Min. total reactive power (ID00097)

The incorrect texts appear during use of the following tools and GSD files:

- STEP 7 (TIA Portal) V13 SP1
- STEP 7 (TIA Portal) V5.5 SP4
- GSD file GSDML-V2.31-ET200SP-20151126

This error will be corrected in the next versions of the tools and GSD files.

In the manual for Energy Meter 480VAC ST, Edition 12/2015

Section 6.2 Quality information

With phase-specific measurement with user data variants 154 to 159, the allocation of the quality information in byte 1 of the user data for current and voltage measurement and operating quadrant is identical for all three phases; see following figure.

If you switch between the user data variants for phase-specific measurements, you can therefore keep the evaluation of the quality information unchanged in your user program.

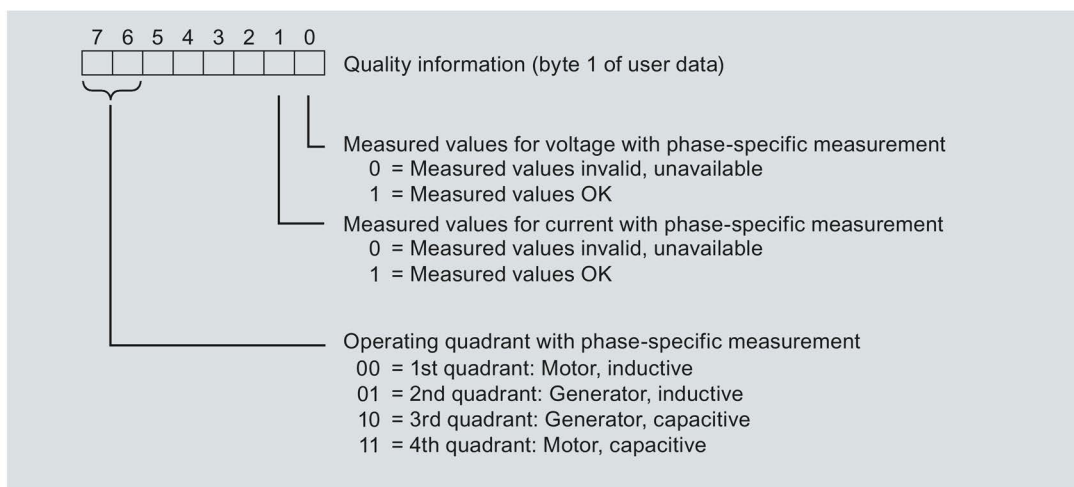
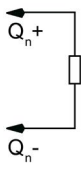
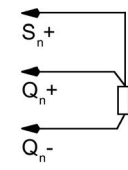
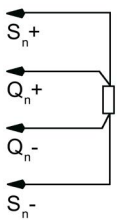

Figure 2-4 Allocation of the quality information for user data variants 154 to 159

Manual for AQ 2xU/I HF, Edition 02/2014

Section 3.1 Wiring and block diagram, pin assignment

You can now also use the 3-wire connection in addition to the 2-wire and 4-wire connection for the analog module AQ 2xU/I HF.

Pin assignment for AQ 2xU/I HF			Explanation
<p>Voltage 2-wire connection</p> 	<p>Voltage 3-wire connection</p> 	<p>Voltage 4-wire connection</p> 	<ul style="list-style-type: none"> • Qn+: Analog output voltage/current (positive), channel n • Qn-: Analog output voltage/current (negative), channel n • Sn+: Sensor line positive, channel n • Sn-: Sensor line negative, channel n

The 3-wire connection and 4-wire connection make compensation for line impedance possible. The compensation is not possible for 2-wire connections due to the missing sensor cable.

2.4.3 Communications module manuals

Communication module CM DP, Edition 12/2014

The communication module CM DP supports the PROFIsafe protocol V2.

Exception: Fail-safe modules that only support PROFIsafe V1 mode.