

Effective: October 1999  
 Supersedes I.L. 41-223L, dated January 1996  
 ( | ) Denotes Change Since Previous Issue

## Type CVQ Negative Sequence Overvoltage Relay



**Before putting protective relays into service, remove all blocking inserted for the purpose of securing the parts during shipment. Make sure that all moving parts operate freely. Inspect the contacts to see that they are clean and close properly, and operate the relay to check the settings and electrical connections.**

### 1.0 APPLICATION

The type CVQ relay provides instantaneous and time delay detection of negative sequence overvoltage as well as responding with time delay to phase-to-phase undervoltage.

Used in motor protection, the relay protects against system undervoltage, single phasing of the supply and reversal of phase rotation of the supply.

The volt-time characteristic of the relay is that of the CV-7 relay, and the negative sequence overvoltage pickup is adjustable from 5 to 10 percent of rated **line to neutral** voltage.

When one of the three supply circuits to a motor is opened, a negative sequence voltage will appear on the motor side of the open which is approximately equal to  $I_L/I_S$  in per unit where  $I_L$  is positive sequence current flowing prior to opening the phase and  $I_S$  is the motor starting current. For most induction motors this will produce approximately 6% negative sequence voltage even if single phasing occurs at no load because of the effect of the magnetizing requirement of the motor.

If static (i.e., non motor) load is single-phased with a motor or group of motors, the negative sequence voltage will be greater than the value calculated above. Single phasing of a predominately static load produces 50% negative sequence voltage on the load side of the open circuit.

When the relay is used for overvoltage protection the back contacts are made at normal voltage and the negative sequence element is committed to an instantaneous function. The normally open E2 contact may be used for alarm purposes.

### 2.0 CONSTRUCTION & OPERATION

The type CVQ relay consists of a polar unit (E) operating on negative sequence quantities, a negative sequence voltage filter, full wave bridge, a time undervoltage relay (CV), an indicating contactor switch (ICS) and a telephone relay when used. The principal component parts of the relay and their location are shown in Figure 1 (page 2).

#### 2.1 POLAR UNIT

The polar unit consists of a rectangular shaped magnetic frame, an electromagnet, a permanent magnet, and an armature. The poles of the crescent shaped permanent magnet bridge the magnetic frame. The magnetic frame consists of three pieces joined in the rear with two brass rods and silver solder. These non-magnetic joints represent air gaps, which are bridged by two adjustable magnetic shunts. The winding or windings are wound around a magnetic core. The armature is fastened to this core and is free to move in the front air gap. The moving contact is connected to the free end of a leaf spring, which in turn, is fastened to the armature.

*All possible contingencies which may arise during installation, operation or maintenance, and all details and variations of this equipment do not purport to be covered by these instructions. If further information is desired by purchaser regarding this particular installation, operation or maintenance of this equipment, the local ABB representative should be contacted.*

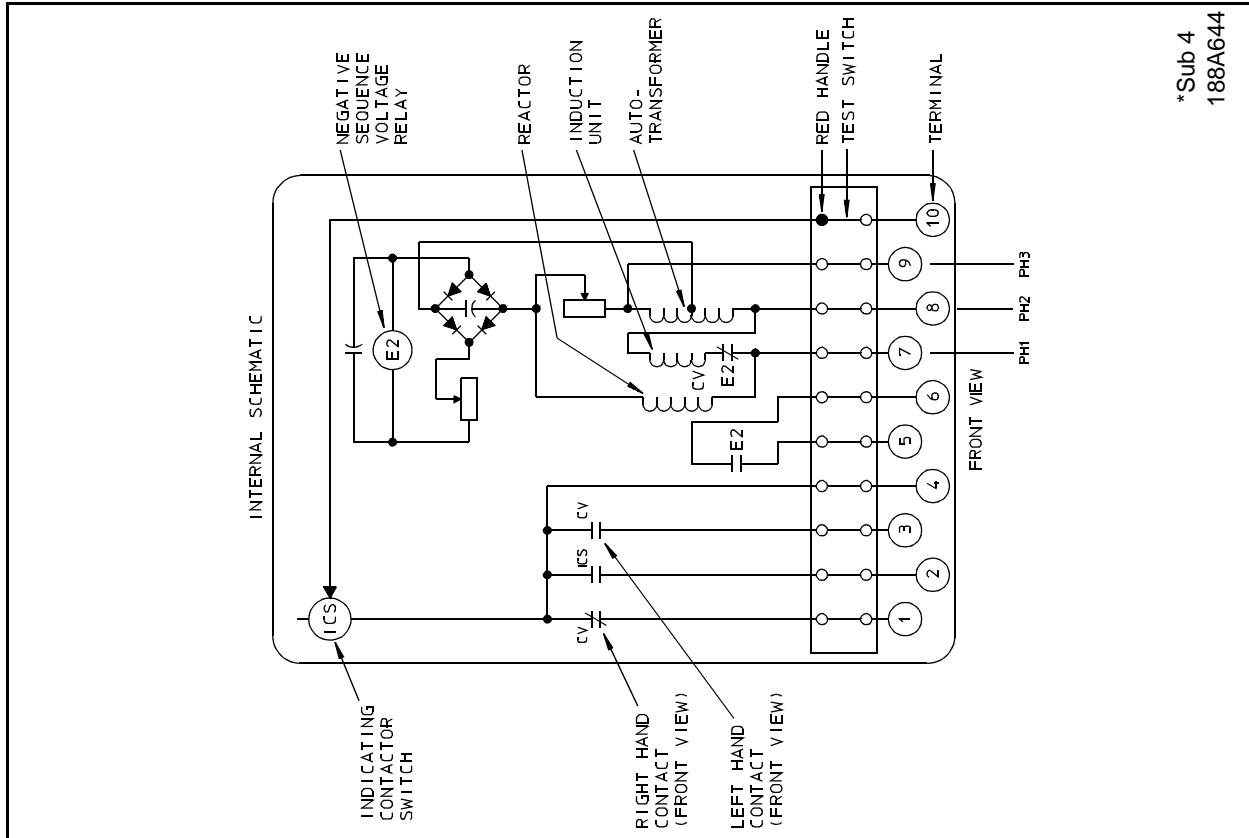

Figure 1. Internal Schematic of the Type CVQ Relay

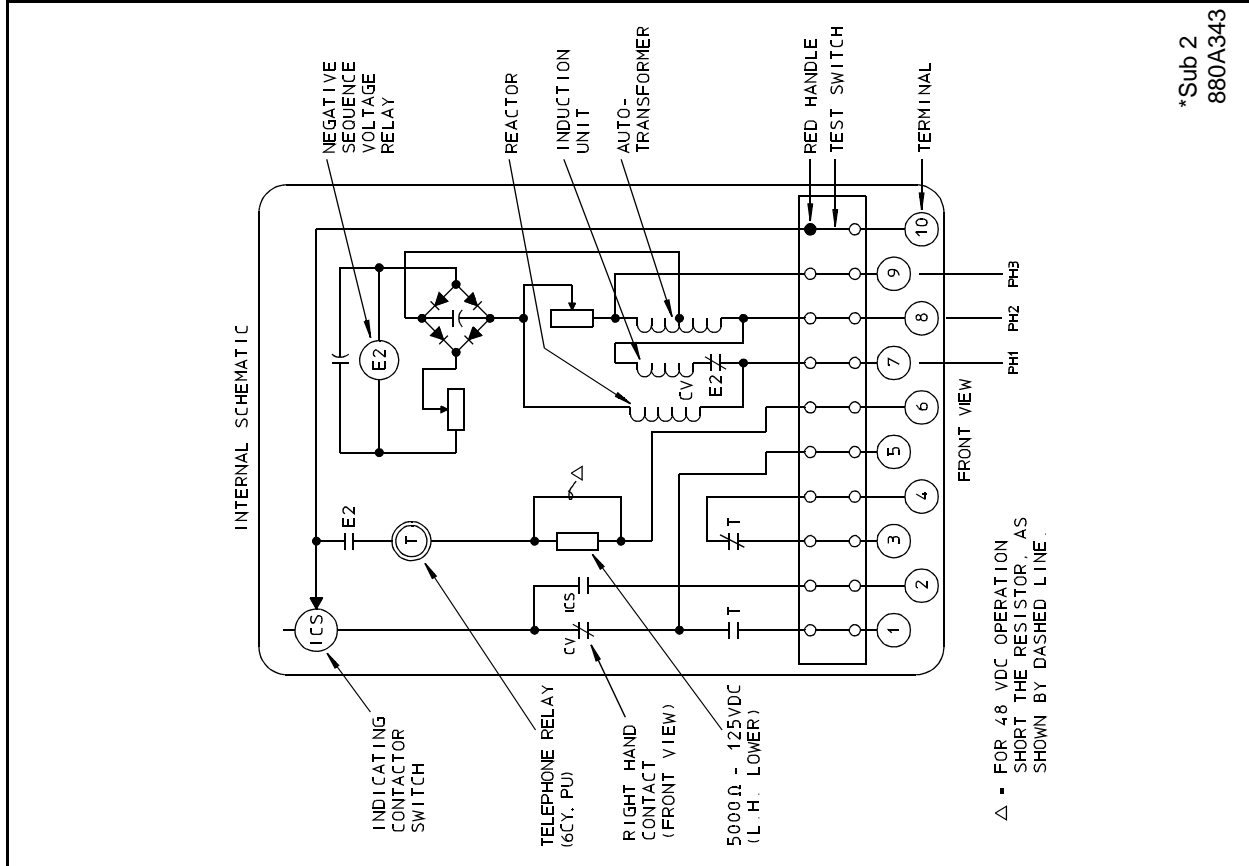

Figure 2. Internal Schematic of Type CVQ Relay with Telephone Relay

## 2.2 NEGATIVE SEQUENCE FILTER

The voltage filter consists of an auto-transformer, reactor, and resistors connected as shown in the internal schematic Figure 1 (page 2).

## 2.3 VOLTAGE UNIT (CV)

The voltage unit operates on the induction-disc principal. A main tapped coil located on the center leg of an "E" type laminated structure produces a flux which divides and returns through the right leg (front view) to lag the main pole flux. The out-of-phase fluxes thus produced in the air gap causes a contact closing torque.

## 2.4 INDICATING CONTACTOR SWITCH (ICS)

The indicating contactor switch is a small dc operated clapper type device. A magnetic armature to which leaf-spring mounted contacts are attached is attracted to the magnetic core upon energization of the switch. When the switch closes, the moving contacts bridge two stationary contacts, completing the trip circuit. Also during this operation two fingers on the armature deflect a spring located on the front of the switch, which allows the operation indicator target to drop. The target is reset from the outside of the case by a push-rod located at the bottom of the case.

The front spring, in addition to holding the target, provides restraint for the armature and thus controls the pickup value of the switch.

## 2.5 FULL WAVE BRIDGE

The full wave bridge consists of four diodes connected to the output of the negative sequence filter. The output is rectified, filtered and fed to the polar unit through an adjustable resistor, which is used to set the sensitivity of the relay.

## 2.6 AUXILIARY TIME DELAY UNIT (T) – WHEN USED

This slugged telephone type unit in series with a resistor, provides a 6 to 7 cycle delay on pick-up. The resistor is to be shorted for 48 Vdc operation as shown in the Internal Schematic of Figure 2 (page 2).

## 3.0 CHARACTERISTICS

**Polar Unit** — The sensitivity of the negative sequence portion of the relay is adjustable between 5

and 10 percent of the rated line to neutral voltage.

**Voltage Unit** — Tap value voltage is the value at which the overvoltage front contact (left-hand, front view) closes. The undervoltage back contact (right-hand, front view) will close within 5% of this value.

When used as an overvoltage relay, the moving contact is initially at rest against the back contact for values of voltage less than tap value. With application of overvoltage greater than tap value, the moving contact moves to close the front contact in a time as shown by the right-hand curves of Figure 3 (page 8).

When energized and used as an undervoltage relay, the moving contact is initially at rest against the front contact for values of voltage greater than tap value. With the reduction of voltage to less than tap value, the moving contact moves to close the back contact in a time as shown by the left-hand curves of Figure 3.

## 3.1 REDUCED FREQUENCY OPERATION

Operation of the E2 unit will occur at approximately 54 Hz with rated positive sequence voltage applied when set for 5% negative-sequence pickup at 60 Hz. With a 10% setting, operation occurs at approximately 48 Hz.

## 3.2 TRIP CIRCUIT

The main contacts will safely close 30 amperes at 250 volts dc and the seal-in contacts of the indicating contactor switch will safely carry this current long enough to trip a circuit breaker.

The indicating contactor switch has two taps that provide a pickup setting of 0.2 or 2 amperes. To change taps requires connecting the lead located in front of the tap block to the desired setting by means of a screw connection.

## 3.3 TRIP CIRCUIT CONSTANTS

Indicating contactor switch –	0.2 amp tap	6.5 ohms dc resistance.
	2.0 amp tap	0.15 ohms dc resistance.

## 4.0 ENERGY REQUIREMENTS

The burden of the undervoltage CV unit at rated voltage are as follows:

Rated <sup>a</sup> Voltage	Taps 120 Volt Relay	Volt Amps	Power Factor	Watts
120 Volts	55	10.0	.38	3.8
	64	7.0	.35	2.5
	70	5.8	.34	2.0
	82	4.0	.33	1.3
	93	3.1	.31	1.0
	105	2.4	.29	.7
	120	1.8	.28	.5
	140	1.3	.26	.3

*a. These relays will continuously withstand either 110% of rated voltage or tap value voltage, whichever is higher.*

The burden of the negative sequence filter at rated voltage is as follows:

Volt Amperes	
Phase 1	58.4
Phase 2	10.5
Phase 3	52.2

## 5.0 SETTINGS

### 5.1 POLAR UNIT

The relay will be shipped adjusted for 5% negative sequence sensitivity. Other settings may be made as indicated under Section 8, “**Calibration**”.

### 5.2 CV UNIT

The setting of the CV unit can be defined either by tap setting and time dial position; or by tap setting and a specific time of operation at some percentage of tap value voltage (e.g. on CV-7 120 volt tap setting and 2 time dial position; or 120 volt tap setting and 1.8 seconds at 140% of tap value voltage). See figure 3 on page 8.

To provide selective circuit breaker operation, a minimum coordinating time of 0.3 seconds plus circuit breaker time is recommended between the relay being set and the relays with which coordination is to be effected.

The connector screw on the terminal plate above the time dial connects various turns of the operating coil. By placing this screw in the various terminal plate holes, the relay will just close its front contacts at the corresponding tap value of 55-64-70-82-93-105-120-140 volts or as marked on the terminal plate.

The nylon screw on the terminal plate holds the tap plate in position when taps are being changed. To use the position on the terminal plate in which the nylon screw is used, remove the nylon screw and place it in one of the unused holes. Then remove the tap screw and insert it in the terminal plate hole.

### 5.3 MOTOR PROTECTION SETTINGS

For motor protection a tap setting of 75 to 85% of normal line to line voltages and a time dial setting of 6 or more should be satisfactory for protecting the motor and overriding voltage variations for which tripping is not desired.

### 5.4 NEGATIVE SEQUENCE FILTER

No setting required.

### 5.5 INDICATING CONTACTOR SWITCH (ICS)

The only setting required on the ICS unit is the selection of the 0.2 or 2.0 ampere tap setting. This selection is made by connecting the lead located in the front of the tap block to the desired setting by means of the connecting screw. The 0.2 ampere setting is recommended where an auxiliary relay is to be operated and the 2.0 ampere setting is recommended where direct tripping of a circuit breaker is to be accomplished.

### 5.6 RESISTOR (FOR TELEPHONE RELAY)

The relay is shipped with resistor in series with telephone relay for 125 Vdc operation. For 48 Vdc operation this resistor is to be shorted.

## 6.0 INSTALLATION

The relays should be mounted on switchboard panels or their equivalent in a location free from dirt, moisture, excessive vibration and heat. Mount the relay vertically by means of the rear mounting stud or studs for the type FT projection case or by means of the four mounting holes on the flange for the semi-flush type FT case. Either the stud or the mounting screws may be utilized for grounding the relay. External toothed washers are provided for use in the locations shown on the outline and drilling plan to facilitate making a good electrical connection between the relay case, its mounting screws or studs, and the relay panel. Ground Wires are affixed to the mounting screws or studs as required for poorly grounded or insulating panels. Other electrical

connections may be made directly to the terminals by means of screws for steel panel mounting or to the terminal stud furnished with the relay for thick panel mounting. The terminal stud may be easily removed or inserted by locking two nuts on the stud and then turning the proper nut with a wrench.

For detail information on the FT case refer to I.L. 41-076.

## 7.0 ADJUSTMENTS & MAINTENANCE

The proper adjustments to insure correct operation of this relay have been made at the factory. Upon receipt of the relay, no adjustments, other than those covered under Section 5, "**SETTINGS**" (page 4), should be required.

### 7.1 ROUTINE TESTS

The following tests are recommended when the relay is received from the factory. If the relay does not perform as specified below, the relay either is not properly calibrated or it contains a defect.

Connect relay per test circuit Figure 6 (page 11). Electrical checks should be made with the relay mounted in its case.

#### 7.1.1 Negative Sequence Filter

The filter is adjusted for balance in the factory and no further adjustments or maintenances should be required. The nominal voltage output of the filters on positive sequence is approximately zero. This serves as a convenient check on the balance of the filter. If any two input leads to the potential filter should be interchanged, a high voltage occurs across the output terminals of the filter.

#### 7.1.2 Polar Unit

Adjust variable auto-transformer (figure 6, page 11) so that an increasing voltage can be seen on the voltmeter. Note at what voltage the polar unit operates. This voltage should be 10.4 volts  $\pm$  0.3 volts.

This corresponds to the 5% sensitivity adjustment. For other sensitivities see Table 1 under calibration.

#### 7.1.3 CV Unit

##### 7.1.3.1 Contact

a) For relays identified with a "T", located at lower

left of stationary contact block, the index on the movement frame will coincide with the "0" mark on the time dial when the stationary contact has moved through approximately one-half of its normal deflection. Therefore, with the stationary contact resting against the backstop, the index mark is offset to the right of the "0" mark by approximately .020". (For the CV-7 element, the follow on the back contact should be approximately 1/64".) The placement of the various time dial positions in line with the index mark will give operating times as shown on the time voltage curves of Figure 3 (page 8). For double trip relays, the follow on the stationary contacts should be approximately 1/32".

(For relay without an identifying "T")

b) By turning the time dial, move the moving contacts until they deflect the stationary contact to a position where the stationary contact is resting against its backstop. The index mark located on the movement frame should coincide with the "0" mark on the time dial. For double trip relays, the follow on the stationary contacts should be approximately 1/64".

#### 7.1.3.2 Minimum Trip Voltage

Set the time dial to position #6. Alternately apply tap value voltage plus 3% and tap value voltage minus 3%. The moving contact should leave the backstop at tap value voltage plus 3% and should return to the backstop at tap value voltage minus 3%.

#### 7.1.3.3 Time Curve

Set time dial at #6 dial position. Energize terminals 7 and 8 of relay with 140% of tap value voltage. The operating time of relay should be 5.9 seconds. The reset time of relay should be 5.7 seconds.

#### 7.1.4 Indicating Contactor Switch (ICS)

Close the main relay contacts and pass sufficient dc current through the trip circuit to close the contacts of the ICS. This value of current should not be greater than the particular ICS setting being used. The indicator target should drop freely.

The bridging moving contact should touch both stationary contacts simultaneously.

## 7.2 ROUTINE MAINTENANCE

All relays should be inspected periodically and the time of operation should be checked at least once every year or at such other time intervals as may be indicated by experience to be suitable to the particular application.

All contacts should be periodically cleaned. A contact burnisher style 182A836H01 is recommended for this purpose. **The use of abrasive material for cleaning contacts is not recommended**, because of the danger of embedding small particles in the face of the soft silver contact and thus impairing the contact.

## 8.0 CALIBRATION

Use the following procedure for calibrating the relay if the relay has been taken apart for repairs, or the adjustments have been disturbed. This procedure should not be used until it is apparent that the relay is not in proper working order (See "Acceptance Check"). Electrical checks should be made with the relay mounted in its case.

### 8.1 NEGATIVE SEQUENCE VOLTAGE FILTER

- A. Apply 120 volts balanced 3 phase voltage 60 hertz to terminals 7, 8, and 9 of the relay, making sure that phase A, B, and C of the applied voltage is connected to terminals 7, 8, and 9 respectively.
- B. Using a calibrated high resistance voltmeter of 2000 ohms per volt or more, measure the voltage between the tap on auto-transformer (middle terminal, upper right-hand reactor, front view) and the tap on the adjustable 2" resistor. If the voltage is high (40 to 50 volts) the filter is probably improperly connected. If properly connected, the voltage will be low. Using a low range (approximately 5 volts) move the adjustable tap until the voltage reads a minimum. This value should be less than 1.5 volts.

### 8.2 POLAR UNIT

#### 8.2.1 Contacts

Place a .060 to .070 inch feeler gage between the right-hand pole face and the armature. This gap should be measured near the front of the right-hand pole face. Bring up the backstop screw until it just makes with the moving contact. Place gage between contact and the stationary contact on the left-hand side of the polar unit, and adjust stationary contacts for 0.046 inches. Bring up the stationary contact until

it just makes with the gage and lock in place. On double trip relays, adjust the other set of contact gaps to close simultaneously.

#### 8.2.2 Minimum Trip Voltage

Short out the adjustable resistor in series with the polar element. Using the test circuit of Figure 6, (page 11) adjust the right-hand shunt of the polar unit so that it toggles over with  $3.3 \pm 0.17$  volts on the voltmeter. Remove short circuit from the resistor and adjust this resistor so that the polar unit will close its contacts to the left with  $10.4 \pm 0.52$  volts on the voltmeter. For other sensitivities as indicated in Table 1, adjust for the voltage shown. Block polar unit contacts closed to the right before proceeding with CV calibration.

Table 1:

Volts on Voltmeter	% of Line to Neutral
10.4	5
12.5	6
14.5	7
16.6	8
18.7	9
20.8	10

Polar unit flux paths are shown in Figure 7 (page 12) with balanced air gaps, permanent magnet flux flows in two paths, one through the front, and one through the rear gaps. This flux produces north and south poles, as shown. By turning the left shunt in, some of the flux is forced through the armature, making it a north pole. Thus, reducing the left-hand rear gap will produce a force tending to pull the armature to the right. Similarly, reducing the right-hand gap will make the armature a south pole and produce a force tending to pull the armature to the left.

### 8.3 CALIBRATION OF POLAR UNIT

If the relay has been dismantled or the calibration has been disturbed, use the following procedure for calibration.

With the permanent magnet removed, see that the moving armature floats in the central area of the air-gap between the poles of the polar unit frame. If necessary, loosen the core screw in the center rear of the unit and shift the core and contact assembly until the armature floats. (This can best be done with the polar unit removed from the relay.) Then retighten the core screw and replace the permanent magnet

with the dimple (north pole) on the magnet to the right when viewed from the front.

## 9.0 POLAR UNITS - GENERAL

The following mechanical adjustments are given as a guide, and some deviation from them may be necessary to obtain proper electrical calibration.

### 9.1 MAGNETIC SHUNT ADJUSTMENT

The sensitivity of the polar unit is adjusted by means of two magnetic, screw-type shunts at the rear of the unit, as shown in Figure 7 (page 12). These shunt screws are held in proper adjustment by a flat strip spring across the back of the polar unit frame, so no locking screws are required. Looking at the relay, front view turning out the right-hand air gap decreases the amount of current required to close the right-hand contact. Conversely, drawing out the left-hand shunt increases the amount of current required to close the right-hand contact, or decreases the amount of current required to close the left-hand contact (with the proper direction of current flow). Also, if a relay trips to the right at the proper current, the dropout current can be raised by turning in the right-hand shunt. The two shunt-screw adjustments are not independent, however, a certain amount of trimming adjustment of both shunt screws is generally necessary to obtain the desired pickup and dropout calibration.

In general, the more the two shunt screws are turned out, the greater the toggle action will be, and as a result, the lower the dropout current. For the tripping units, toggle action is desirable, with a dropout current around 75 percent of the pickup current.

The electrical calibration of the polar unit is also affected by the contact adjustment as this changes the position of the polar unit armature. Do not change the contact adjustment without rechecking the electrical calibration.

#### 9.1.1 CV Unit

##### 9.1.1.1 Contact (see 7.1.3.1)

- a) For relays identified with a "T", located at lower-left of stationary contact block, the index mark on the movement frame will coincide with the "0" mark on the time dial when the stationary contact has moved through approximately one-half of its normal deflection. Therefore, with the stationary contact resting against the backstop, the index mark is offset to the right of the "0" mark by

approximately .020". (For the type CV-7 relays, the follow on the back contact should be approximately 1/64"). The placement of the various time dial positions in line with the index mark will give operating times as shown on the respective time current curves. For double trip relays, the follow on the stationary contacts should be approximately 1/32".

- b) By turning the time dial, move the moving contacts until they deflect the stationary contact to a position where the stationary contact is resting against its backstop. The index mark located on the movement frame should coincide with the "0" mark on the time dial. For double trip relays, the follow on the stationary contacts should be approximately 1/64".

#### 9.1.1.2 Minimum Trip Voltage

The adjustment of the spring tension in setting the minimum trip voltage value of the relay is most conveniently made with the damping magnet removed.

With the time dial set on "0" wind up the spiral spring by means of the spring adjuster until approximately 6 3/4 convolutions show. Set the relay on the minimum tap setting and the time dial to position 6.

Adjust the control spring tension so that the moving contact will leave the backstop of the time dial at tap value voltage +1.0% and will return to the backstop at tap value voltage -1.0%.

Energize terminal 7 and 8 of relay with 140% of tap value voltage. Adjust the permanent magnet keeper until the operating time is 5.9 seconds. Measure the reset time of the disc from the stationary front contact to the stationary back contact. This time should be 5.7 seconds.

#### 9.1.2 Indicating Contactor Switch – Unit (ICS)

Close the main relay contacts and pass sufficient dc current through the trip circuit to close the contacts of the ICS. This value of current should not be greater than the particular ICS setting being used. The indicator target should drop freely.

## 10.0 RENEWAL PARTS

Repair work can be done most satisfactorily at the factory. However, interchangeable parts can be furnished to those equipped for doing repair work. When ordering parts, always give the complete nameplate data.



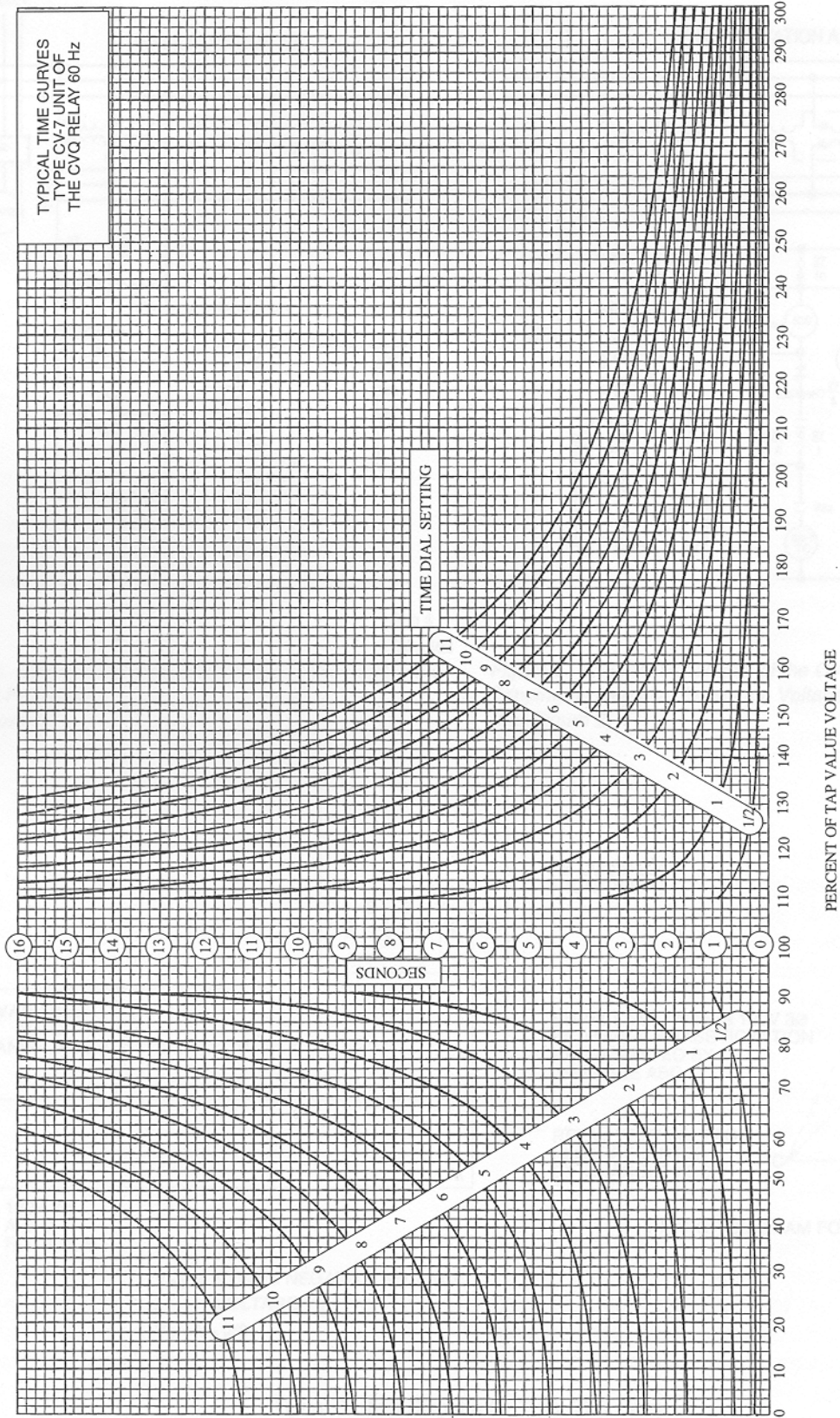

Sub 2  
Curve 406C883

Figure 3. Typical 60 hertz Time Curves of the CV-7 Unit of the Type CVQ Relay



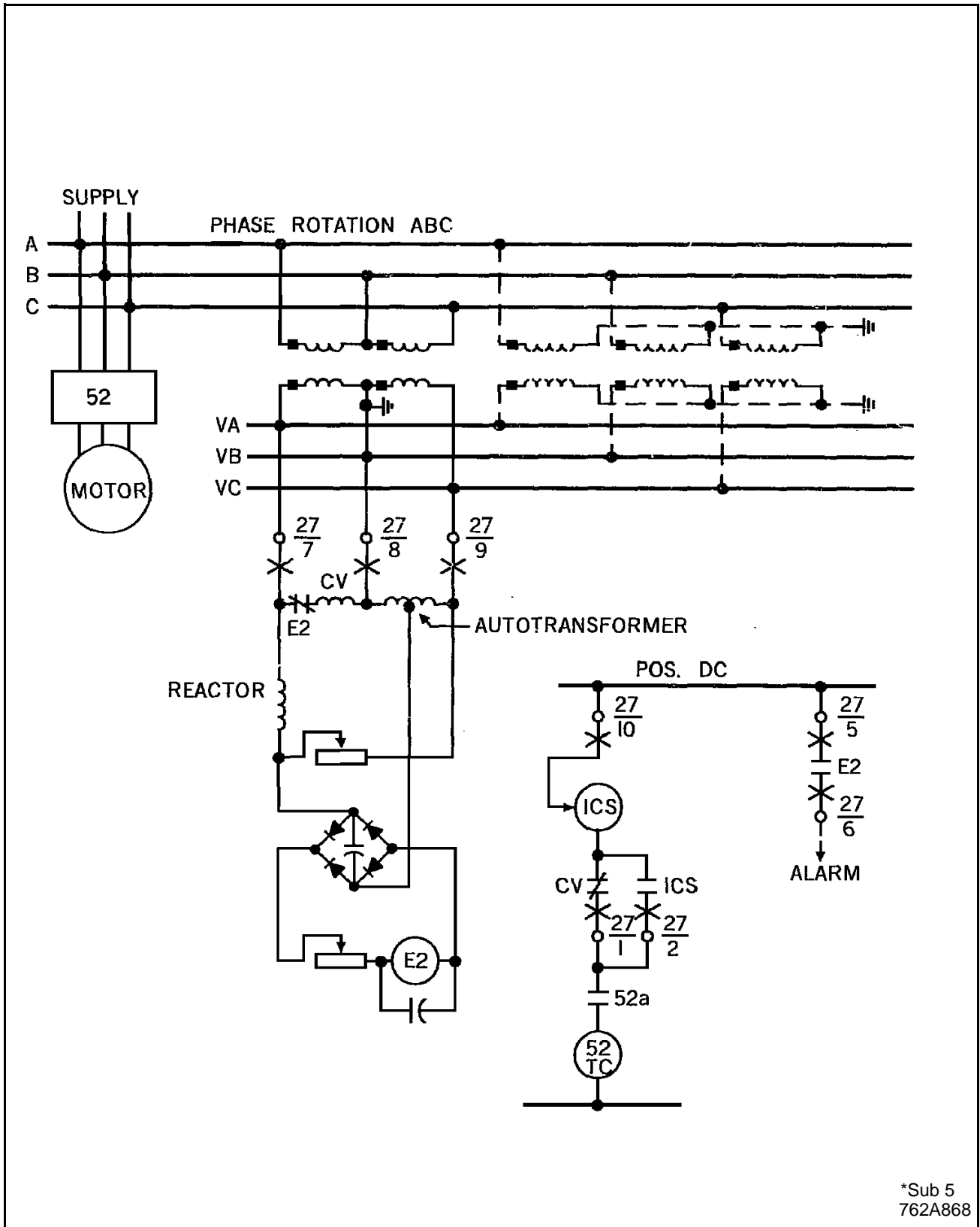

\*Sub 5  
762A868

Figure 4. External Schematic of the type CVQ Relay used in Motor Protection  
(For Internal Schematic 188A644 Figure 1)

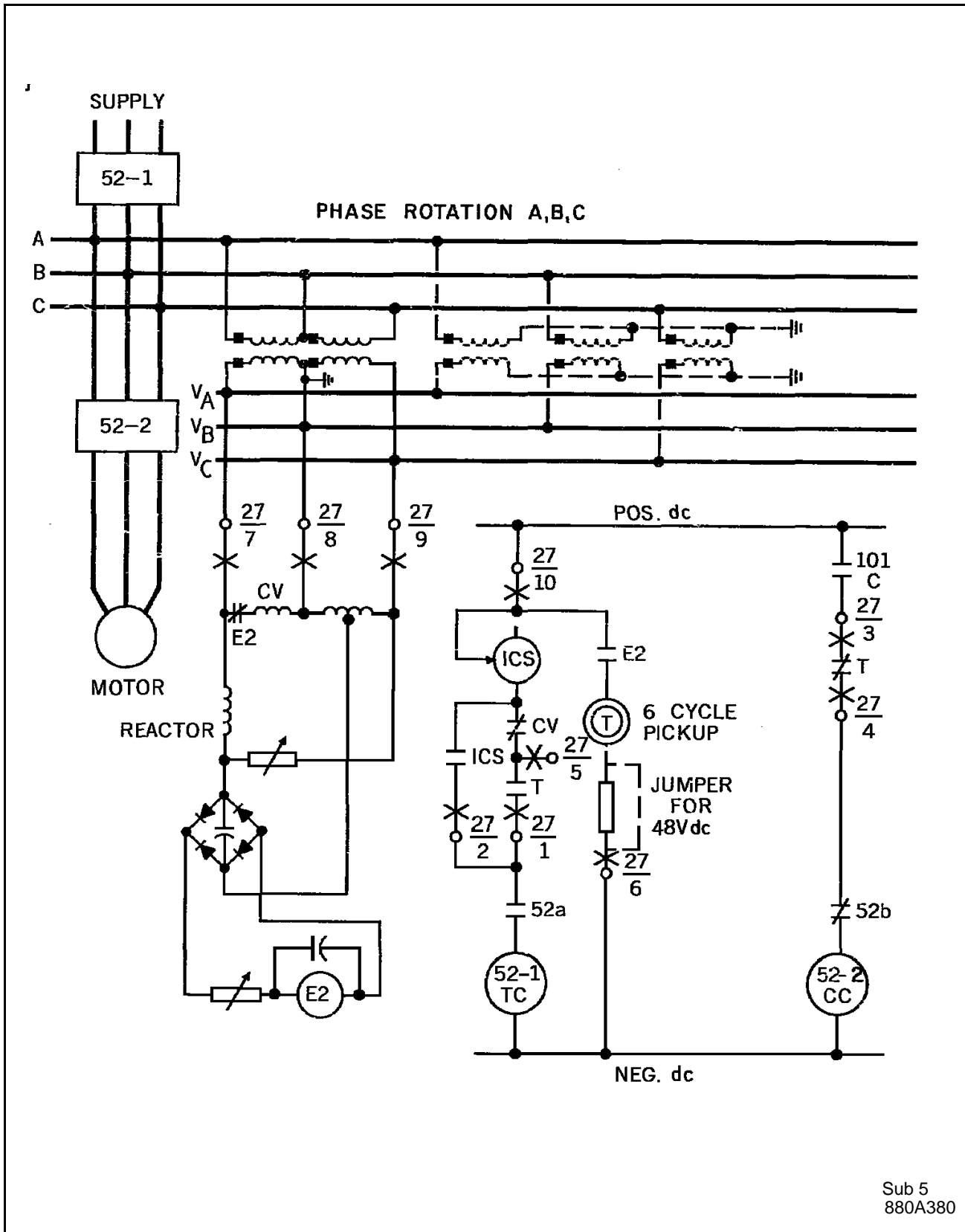

Sub 5  
880A380

Figure 5. External Schematic of the CVQ Relay used for Tripping on Negative Sequence Voltage only  
(For Internal Schematic 880A343 Figure 2)

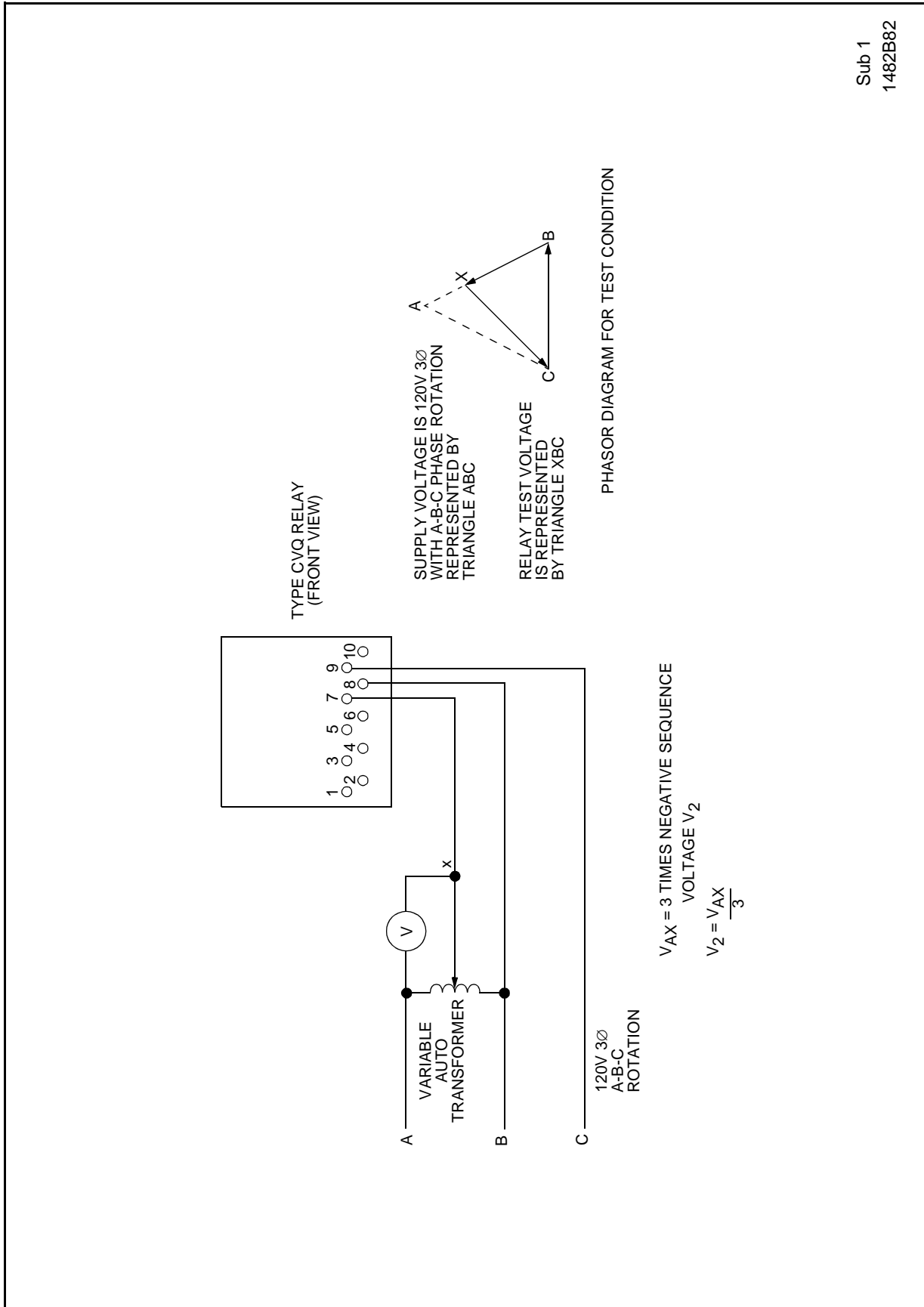

Figure 6. Test Diagram for Type CVQ Relay

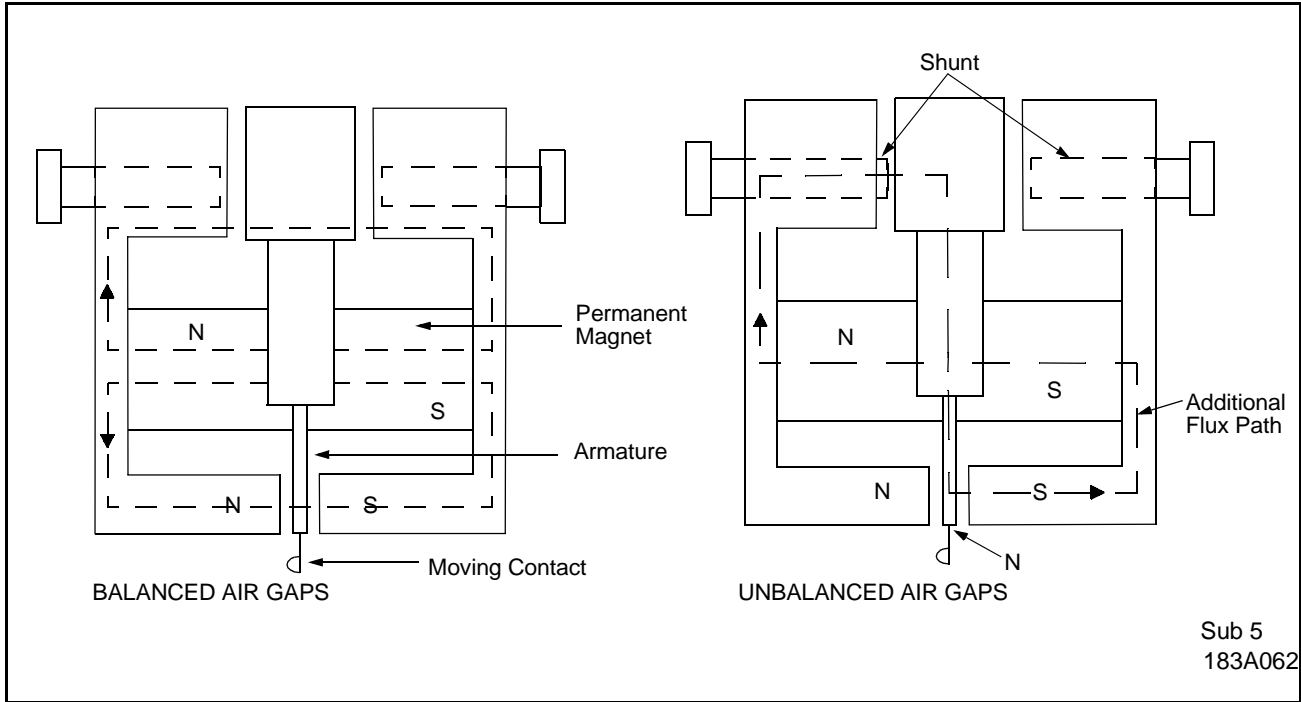

Figure 7. Polar Unit - permanent magnet flux paths

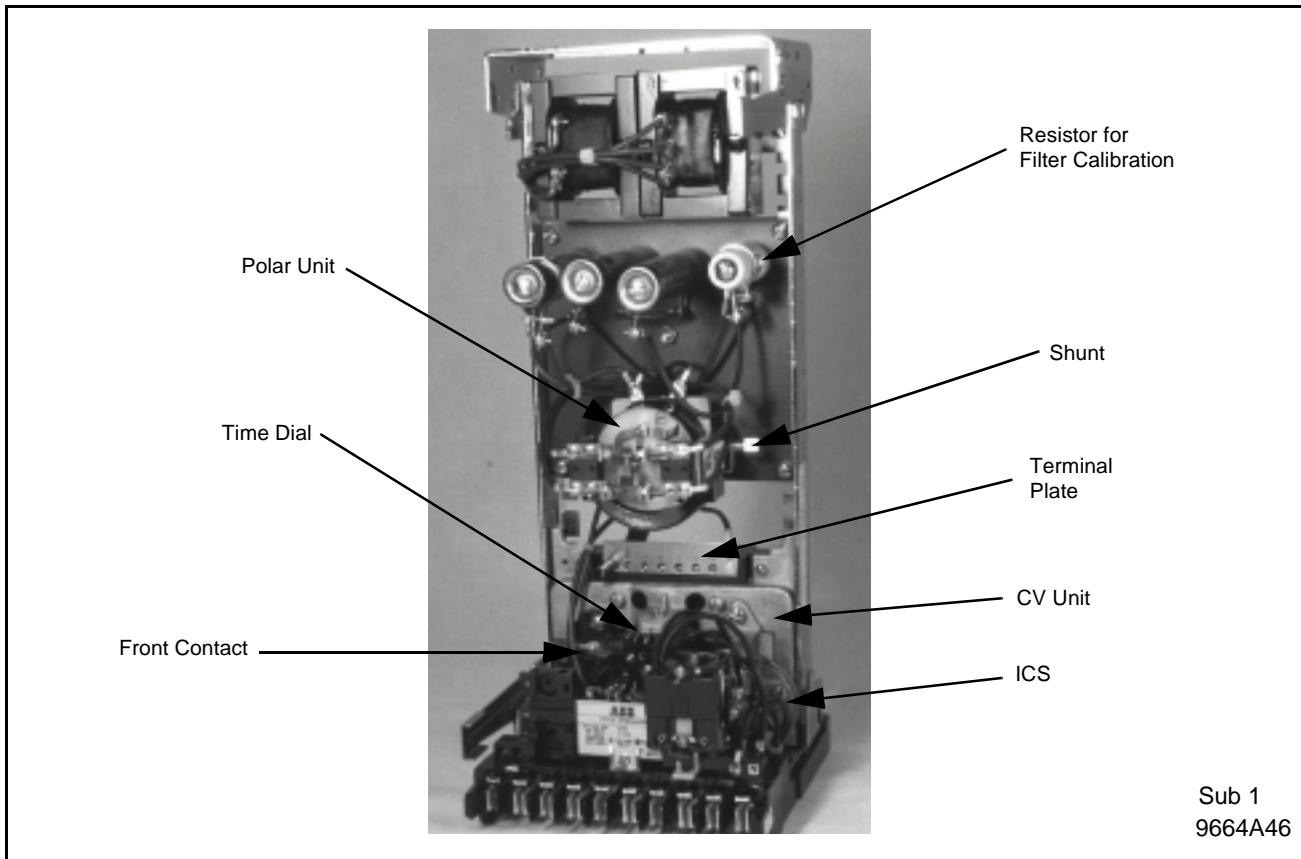
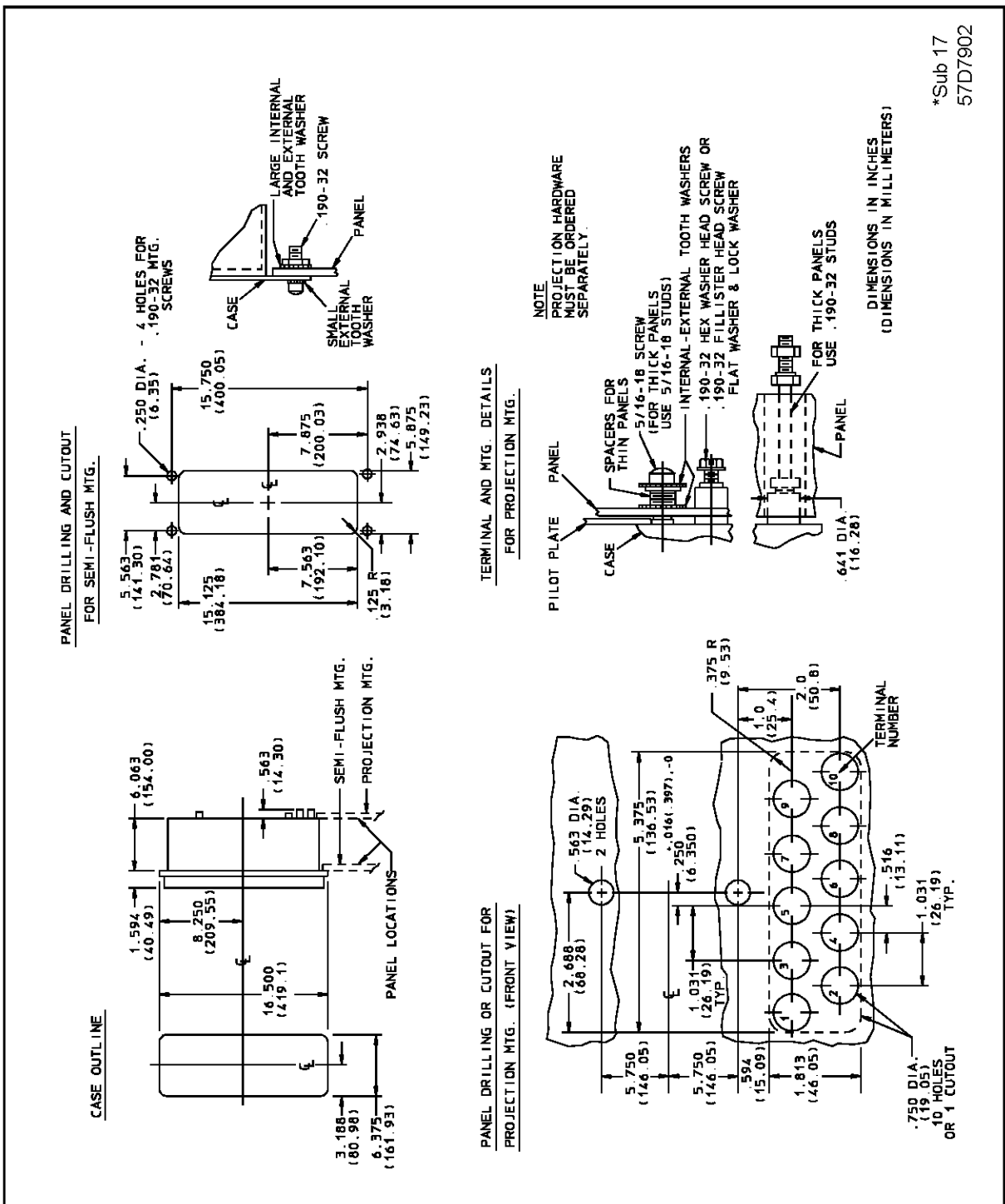

Figure 8. CVQ Relay without Case (Front View)



**Reserved for Notes**

**Reserved for Notes**





ABB Inc.

4300 Coral Ridge Drive  
Coral Springs, Florida 33065

Telephone: +1 954-752-6700

Fax: +1 954-345-5329

[www.abb.com/substation\\_automation](http://www.abb.com/substation_automation)

IL 41-223 - Revision N