

Edwards SAPIEN 3 Transcatheter Heart Valve with the Edwards Commander Delivery System

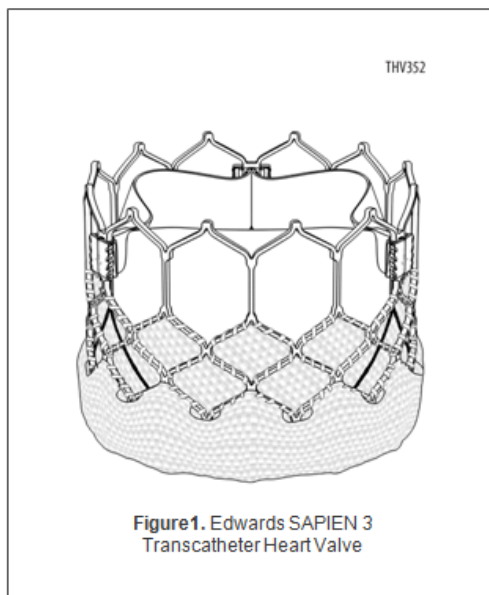

Instructions for Use

CAUTION: Federal (USA) law restricts these devices to sale by or on the order of a physician.

Implantation of the transcatheter heart valve should be performed only by physicians who have received Edwards Lifesciences training. The implanting physician should be experienced in balloon aortic valvuloplasty.

Please verify that you have the latest version of the instructions for use prior to using the device by visiting <http://THVIFU.edwards.com> or by calling 1.800.822.9837. In order to access the instructions for use, an IFU Code will be required.

STERILE: The THV is supplied sterilized with glutaraldehyde solution. The delivery system, eSheath introducer set, and crimper are supplied sterilized with ethylene oxide gas.

1.0 Device Description

• Edwards SAPIEN 3 Transcatheter Heart Valve- Model 9600TFX (Figure 1)

The Edwards SAPIEN 3 Transcatheter Heart Valve (THV) is comprised of a balloon-expandable, radiopaque, cobalt-chromium frame, trileaflet bovine pericardial tissue valve, and polyethylene terephthalate (PET) fabric skirt. The leaflets are treated according to the Carpentier-Edwards ThermaFix process.

Table 1

Valve Size	Height
20 mm	15.5 mm
23 mm	18 mm
26 mm	20 mm
29 mm	22.5 mm

Table 2

Native Valve Annulus Size (TEE)	Native Valve Annulus Size (CT)		THV Size
	Area	Area Derived Diameter	
16-19 mm	273 – 345 mm ²	18.6-21 mm	20 mm
18-22 mm	338 – 430 mm ²	20.7-23.4 mm	23 mm
21-25 mm	430 – 546 mm ²	23.4-26.4 mm	26 mm
24-28 mm	540 – 683 mm ²	26.2-29.5 mm	29 mm

THV size recommendations are based on native valve annulus size, as measured by transesophageal echocardiography (TEE) or computed tomography (CT). Patient anatomical factors and multiple imaging modalities should be considered during THV size selection. Note: Risks associated with undersizing and oversizing should be considered.

• Edwards Commander Delivery System (Figure 2)

The Edwards Commander delivery system (usable length 105 cm) is used for delivery of the Edwards SAPIEN 3 transcatheter heart valve and consists of a Flex Catheter to aid in valve alignment to the balloon, tracking, and positioning of the THV. The delivery system includes a tapered tip to facilitate crossing of the native valve. The handle contains a Flex Wheel to control flexing of the Flex Catheter, and a Balloon Lock and Fine Adjustment Wheel to facilitate valve alignment and positioning of the valve within the native annulus. A stylet is included within the guidewire lumen of the delivery system. The Balloon Catheter has radiopaque Valve Alignment Markers defining the working length of the balloon. A radiopaque Center Marker in the balloon is provided to help with valve positioning. A radiopaque Triple Marker proximal to the balloon indicates the Flex Catheter position during deployment. The inflation parameters for THV deployment are:

Table 3

Model	Nominal Balloon Diameter	Nominal Inflation Volume	Rated Burst Pressure (RBP)
9600LDS20	20 mm	11 mL	7 atm
9600LDS23	23 mm	17 mL	7 atm
9600LDS26	26 mm	23 mL	7 atm
9600LDS29	29 mm	33 mL	7 atm

Figure 2 Edwards Commander Delivery System

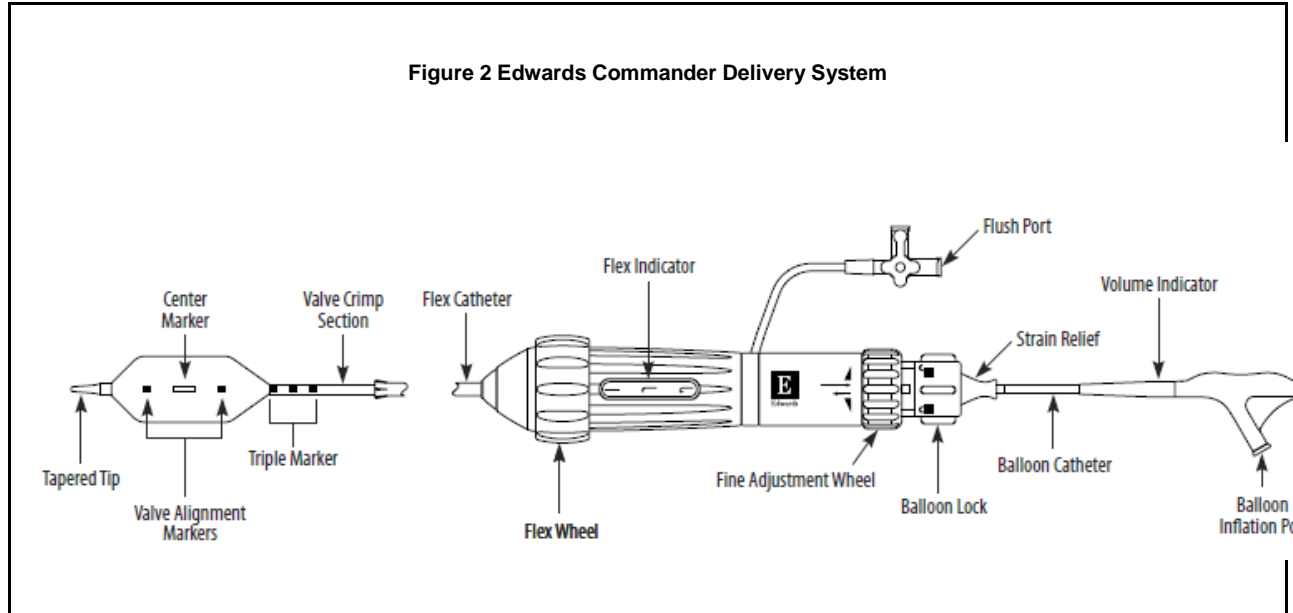

• **Qualcrimp Crimping Accessory (Figure 3)**

The Qualcrimp crimping accessory (packaged with the Edwards Commander delivery system) is used during crimping of the THV.

Figure 3

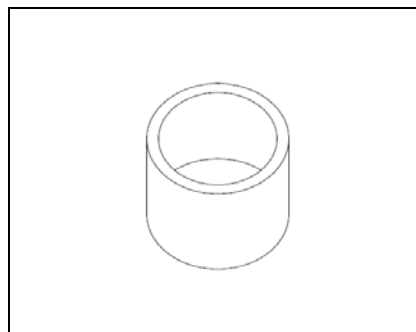

Laminated Qualcrimp

• **Edwards eSheath Introducer Set**

Refer to the Edwards eSheath Introducer Set for device description.

• **Edwards Crimper**

Refer to the Edwards Crimper instructions for use for device description.

2.0 Indications

The Edwards SAPIEN 3 Transcatheter Heart Valve (THV), model 9600TFX, and accessories are indicated for relief of aortic stenosis in patients with symptomatic heart disease due to severe native calcific aortic stenosis who are judged by a heart team, including a cardiac surgeon, to be at high or greater risk for open surgical therapy (i.e., Society of Thoracic Surgeons operative risk score $\geq 8\%$ or at a $\geq 15\%$ risk of mortality at 30 days).

3.0 Contraindications

The THV and delivery systems are contraindicated in patients who cannot tolerate an anticoagulation/antiplatelet regimen or who have active bacterial endocarditis or other active infections.

4.0 Warnings

- Observation of the pacing lead throughout the procedure is essential to avoid the potential risk of pacing lead perforation.
- There is an increased risk of stroke in transcatheter aortic valve replacement procedures, as compared to balloon aortic valvuloplasty or other standard treatments.
- The devices are designed, intended, and distributed for single use only. **Do not resterilize or reuse the devices.** There are no data to support the sterility, nonpyrogenicity, and functionality of the devices after reprocessing.
- Incorrect sizing of the THV may lead to paravalvular leak, migration, embolization and/or annular rupture.
- Accelerated deterioration of the THV may occur in patients with an altered calcium metabolism.
- Prior to delivery, the THV must remain hydrated at all times and cannot be exposed to solutions other than its shipping storage solution and sterile physiologic rinsing solution. THV leaflets mishandled or damaged during any part of the procedure will require replacement of the THV.
- Caution should be exercised in implanting a THV in patients with clinically significant coronary artery disease.
- Patients with pre-existing mitral valve devices should be carefully assessed prior to implantation of the THV to ensure proper THV positioning and deployment.
- Do not use the THV if the tamper evident seal is broken, the storage solution does not completely cover the THV, the temperature indicator has been activated, the THV is damaged, or the expiration date has elapsed.
- Do not mishandle the delivery system or use it if the packaging or any components are not sterile, have been opened or are damaged (e.g. kinked or stretched), or the expiration date has elapsed.
- Use of excessive contrast media may lead to renal failure. Measure the patient's creatinine level prior to the procedure. Contrast media usage should be monitored.
- Patient injury could occur if the delivery system is not un-flexed prior to removal.
- Care should be exercised in patients with hypersensitivities to cobalt, nickel, chromium, molybdenum, titanium, manganese, silicon, and/or polymeric materials.
- The procedure should be conducted under fluoroscopic guidance. Some fluoroscopically guided procedures are associated with a risk of radiation injury to the skin. These injuries may be painful, disfiguring, and long-lasting.
- THV recipients should be maintained on anticoagulant/antiplatelet therapy, except when contraindicated, as determined by their physician. This device has not been tested for use without anticoagulation.
- Do not add or apply antibiotics to the storage solution, rinse solutions, or to the THV.

5.0 Precautions

- Long-term durability has not been established for the THV. Regular medical follow-up is advised to evaluate THV performance.
- Glutaraldehyde may cause irritation of the skin, eyes, nose and throat. Avoid prolonged or repeated exposure to, or breathing of, the solution. Use only with adequate ventilation. If skin contact occurs, immediately flush the affected area with water; in the event of contact with eyes, seek immediate medical attention. For more information about glutaraldehyde exposure, refer to the Material Safety Data Sheet available from Edwards Lifesciences.

- To maintain proper valve leaflet coaptation, do not overinflate the deployment balloon.
- Appropriate antibiotic prophylaxis is recommended post-procedure in patients at risk for prosthetic valve infection and endocarditis.
- Safety, effectiveness, and durability have not been established for valve-in-valve procedures.
- Safety and effectiveness have not been established for patients with the following characteristics/comorbidities:
 - Non-calcified aortic annulus
 - Severe ventricular dysfunction with ejection fraction < 20%
 - Congenital unicuspid or congenital bicuspid aortic valve
 - Mixed aortic valve disease (aortic stenosis and aortic regurgitation with predominant aortic regurgitation > 3+)
 - Pre-existing prosthetic heart valve or prosthetic ring in any position
 - Severe mitral annular calcification (MAC), severe (> 3+) mitral insufficiency, or Gorlin syndrome
 - Blood dyscrasias defined as: leukopenia (WBC < 3000 cells/mL), acute anemia (Hb < 9 g/dL), thrombocytopenia (platelet count < 50,000 cells/mL), or history of bleeding diathesis or coagulopathy
 - Hypertrophic cardiomyopathy with or without obstruction (HOCM)
 - Echocardiographic evidence of intracardiac mass, thrombus, or vegetation
 - A known hypersensitivity or contraindication to aspirin, heparin, ticlopidine (Ticlid™), or clopidogrel (Plavix™), or sensitivity to contrast media, which cannot be adequately premedicated
 - Significant aortic disease, including abdominal aortic or thoracic aneurysm defined as maximal luminal diameter 5 cm or greater; marked tortuosity (hyperacute bend), aortic arch atheroma (especially if thick [> 5 mm], protruding, or ulcerated) or narrowing (especially with calcification and surface irregularities) of the abdominal or thoracic aorta, severe “unfolding” and tortuosity of the thoracic aorta
 - Access characteristics that would preclude safe placement of 14F or 16F Edwards eSheath Introducer Set, such as severe obstructive calcification, severe tortuosity or diameter less than 5.5 mm or 6 mm, respectively
 - Bulky calcified aortic valve leaflets in close proximity to coronary ostia

6.0 Potential Adverse Events

Potential risks associated with the overall procedure including potential access complications associated with standard cardiac catheterization, balloon valvuloplasty, the potential risks of conscious sedation and/or general anesthesia, and the use of angiography:

- Death
- Stroke/transient ischemic attack, clusters or neurological deficit
- Paralysis
- Permanent disability
- Respiratory insufficiency or respiratory failure
- Hemorrhage requiring transfusion or intervention
- Cardiovascular injury including perforation or dissection of vessels, ventricle, myocardium or valvular structures that may require intervention
- Pericardial effusion or cardiac tamponade

- Embolization including air, calcific valve material or thrombus
- Infection including septicemia and endocarditis
- Heart failure
- Myocardial infarction
- Renal insufficiency or renal failure
- Conduction system defect which may require a permanent pacemaker
- Arrhythmia
- Retroperitoneal bleed
- AV fistula or pseudoaneurysm
- Reoperation
- Ischemia or nerve injury
- Restenosis
- Pulmonary edema
- Pleural effusion
- Bleeding
- Anemia
- Abnormal lab values (including electrolyte imbalance)
- Hypertension or hypotension
- Allergic reaction to anesthesia, contrast media, or device materials
- Hematoma
- Syncope
- Pain or changes at the access site
- Exercise intolerance or weakness
- Inflammation
- Angina
- Heart murmur
- Fever

Additional potential risks associated with the use of the THV, delivery system, and/or accessories include:

- Cardiac arrest
- Cardiogenic shock
- Emergency cardiac surgery
- Cardiac failure or low cardiac output
- Coronary flow obstruction/transvalvular flow disturbance
- Device thrombosis requiring intervention
- Valve thrombosis
- Device embolization
- Device migration or malposition requiring intervention
- Valve deployment in unintended location

- Valve stenosis
- Structural valve deterioration (wear, fracture, calcification, leaflet tear/tearing from the stent posts, leaflet retraction, suture line disruption of components of a prosthetic valve, thickening, stenosis)
- Device degeneration
- Paravalvular or transvalvular leak
- Valve regurgitation
- Hemolysis
- Device explants
- Nonstructural dysfunction
- Mechanical failure of delivery system, and/or accessories
- Non-emergent reoperation

7.0 Directions for Use

7.1 Required Equipment

Table 4

Product Name	20 mm System (9600CM20A)	23 mm System (9600CM23A)	26 mm System (9600CM26A)	29 mm System (9600CM29A)
	Model			
Edwards SAPIEN 3 Transcatheter Heart Valve	9600TFX (20 mm)	9600TFX (23 mm)	9600TFX (26 mm)	9600TFX (29 mm)
Edwards Commander Delivery System*	9600LDS20	9600LDS23	9600LDS26	9600LDS29
Edwards eSheath Introducer Set**	914ES	914ES	914ES	916ES
Edwards Balloon Catheter	9350BC16	9350BC20	9350BC23	9350BC25
Inflation devices provided by Edwards Lifesciences				
Edwards Crimper	9600CR			
* Includes the Qualcrimp Crimping Accessory, 2-piece Crimp Stopper and loader				
** Or other compatible sheath provided by Edwards Lifesciences				

Additional Equipment:

- 20 cc syringe or larger (x2)
- 50 cc syringe or larger
- High-pressure 3-way stopcock (x2)
- Standard cardiac catheterization lab equipment
- Fluoroscopy (fixed, mobile or semi-mobile fluoroscopy systems appropriate for use in percutaneous coronary interventions)
- Transesophageal or transthoracic echocardiography capabilities
- Exchange length 0.035 inch (0.89 mm) extra-stiff guidewire
- Temporary pacemaker (PM) and pacing lead
- Sterile rinsing basins, physiological saline, heparinized saline, 15% diluted radiopaque contrast medium
- Sterile table for THV and device preparation

7.2 THV Handling and Preparation

Follow sterile technique during device preparation and implantation.

7.2.1 THV Rinsing Procedure

Before opening the valve jar, carefully examine for evidence of damage (e.g. a cracked jar or lid, leakage, or broken or missing seals).

CAUTION: THVs from containers found to be damaged, leaking, without adequate sterilant, or missing intact seals must not be used for implantation.

Step	Procedure
1	Set up two (2) sterile bowls with at least 500 mL of sterile physiological saline to thoroughly rinse the glutaraldehyde sterilant from the THV.
2	Carefully remove the THV/holder assembly from the jar without touching the tissue. Verify the THV serial identification number with the number on the jar lid and record in the patient information documents. Inspect the THV for any signs of damage to the frame or tissue.
3	<p>Rinse the THV as follows: Place the THV in the first bowl of sterile, physiological saline. Be sure the saline solution completely covers the THV and holder. With the THV and holder submerged, slowly agitate (to gently swirl the THV and holder) back and forth for a minimum of 1 minute. Transfer the THV and holder to the second rinsing bowl of physiological saline and gently agitate for at least one more minute. Ensure the rinse solution in the first bowl is not used. The THV should be left in the final rinse solution until needed to prevent the tissue from drying.</p> <p>CAUTION: Do not allow the THV to come into contact with the bottom or sides of the rinse bowl during agitation or swirling in the rinse solution. Direct contact between the identification tag and THV is also to be avoided during the rinse procedure. No other objects should be placed in the rinse bowls. The THV should be kept hydrated to prevent the tissue from drying.</p>

7.2.2 Prepare the Components

Refer to the Edwards eSheath Introducer Set, Edwards Crimper and Edwards Balloon Catheter instructions for use for device preparation.

Step	Procedure
1	<p>Visually inspect all components for damage. Ensure the Edwards Commander delivery system is fully unflexed and the balloon catheter is fully advanced in the flex catheter.</p> <p>WARNING: To prevent possible damage to the balloon shaft, ensure that the proximal end of the balloon shaft is not subjected to bending.</p>
2	Flush the flex catheter.
3	Carefully remove the distal balloon cover from the delivery system.
4	<p>Remove the stylet from the distal end of the guidewire lumen and set aside. Flush the guidewire lumen with heparinized saline and insert the stylet back into the distal end of the guidewire lumen.</p> <p>Note: Failure to insert the stylet back into the guidewire lumen may result in damage to the lumen during crimping process.</p>
5	Place the delivery system into the default position and make sure that the flex catheter tip is covered by the proximal balloon cover. Unscrew the loader cap from the loader tube and flush the loader cap. Place the loader cap over the proximal balloon cover and onto the flex catheter with the inside of the cap oriented towards the distal tip.
6	<p>Fully advance the balloon catheter in the flex catheter.</p> <p>Peel off the proximal balloon cover over the blue section of the balloon shaft.</p>
7	Attach a 3-way stopcock to the balloon inflation port. Partially fill a 50 cc or larger syringe with 15-20 mL diluted contrast medium and attach to the 3-way stopcock.
8	Fill the inflation device provided by Edwards Lifesciences with excess volume relative to the indicated inflation volume. Lock the inflation device and attach to the 3-way stopcock.
9	Close the 3-way stopcock to the Inflation device provided by Edwards Lifesciences and de-air the system using the 50 cc or larger syringe. Slowly release the plunger and leave zero-pressure in the system.

Step	Procedure															
10	<p>Close the stopcock to the delivery system. By rotating the knob of the inflation device provided by Edwards Lifesciences, transfer the contrast medium into the syringe to achieve the appropriate volume required to deploy the THV, per the following:</p> <table border="1"> <thead> <tr> <th>Delivery System</th> <th>THV Size</th> <th>Inflation Volume</th> </tr> </thead> <tbody> <tr> <td>Model 9600LDS20</td> <td>20 mm</td> <td>11 mL</td> </tr> <tr> <td>Model 9600LDS23</td> <td>23 mm</td> <td>17 mL</td> </tr> <tr> <td>Model 9600LDS26</td> <td>26 mm</td> <td>23 mL</td> </tr> <tr> <td>Model 9600LDS29</td> <td>29 mm</td> <td>33 mL</td> </tr> </tbody> </table>	Delivery System	THV Size	Inflation Volume	Model 9600LDS20	20 mm	11 mL	Model 9600LDS23	23 mm	17 mL	Model 9600LDS26	26 mm	23 mL	Model 9600LDS29	29 mm	33 mL
Delivery System	THV Size	Inflation Volume														
Model 9600LDS20	20 mm	11 mL														
Model 9600LDS23	23 mm	17 mL														
Model 9600LDS26	26 mm	23 mL														
Model 9600LDS29	29 mm	33 mL														
11	<p>Close the stopcock to the 50 cc or larger syringe. Remove the syringe. Verify that the inflation volume is correct and lock the Inflation device provided by Edwards Lifesciences.</p> <p>CAUTION: Maintain the Inflation device provided by Edwards Lifesciences in the locked position until THV deployment.</p>															

7.2.3 Mount and Crimp the THV on the Delivery System

Step	Procedure
1	Set up two (2) additional sterile bowls with at least 100 mL of sterile physiological saline to thoroughly rinse the Qualcrimp crimping accessory.
2	Completely submerge the Qualcrimp crimping accessory in the first bowl and gently compress it to ensure complete saline absorption. Slowly swirl the Qualcrimp crimping accessory for a minimum of 1 minute. Repeat this process in the second bowl.
3	Remove the THV from the holder and remove the ID tag.
4	Attach the 2-piece crimp stopper to the base of the crimper and click into place.
5	With the crimper in the open position, gently place the THV into the crimper aperture. Gradually crimp the THV until it fits into the Qualcrimp crimping accessory.
6	Place the Qualcrimp crimping accessory over the THV making sure the THV is parallel to the edge of the Qualcrimp.
7	Place the THV and Qualcrimp crimping accessory in crimper aperture. Insert the delivery system coaxially within the THV on the Valve Crimp Section (2-3 mm distal to the balloon shaft) with the inflow (fabric cuff end) of the THV towards the distal end of the delivery system.
8	Crimp the THV until it reaches the Qualcrimp Stop located on the 2-piece Crimp Stopper.
9	Gently remove the Qualcrimp crimping accessory from the THV. Remove the Qualcrimp Stop from the Final Stop, leaving the Final Stop in place.
10	Fully crimp the THV until it reaches the Final Stop. NOTE: Ensure that the Valve Crimp Section remains coaxial within the THV.
11	Repeat the full crimp of the THV two more times for a total of three full crimps.
12	Pull the balloon shaft and lock in the default position.
13	Flush the loader with heparinized saline. Immediately advance the THV into the loader until the tapered tip of the delivery system is exposed. CAUTION: To prevent possible leaflet damage, the THV should not remain fully crimped and/or in the loader for over 15 minutes.
14	Attach the loader cap to the loader, re-flush the delivery system through the flush port and close the stopcock to the delivery system. Remove the stylet and flush the guidewire lumen of the delivery system. CAUTION: Keep the THV hydrated until ready for implantation. CAUTION: The physician must verify correct orientation of the THV prior to its implantation; its inflow (fabric cuff end) should be oriented distally towards the tapered tip.

7.3 Valvuloplasty and THV Delivery

Valvuloplasty and THV delivery should be performed under conscious sedation and/or general anesthesia with hemodynamic monitoring in a catheterization lab/hybrid operating room with fluoroscopic and echocardiographic imaging capabilities.

Administer heparin to maintain the ACT at ≥ 250 sec during the procedure.

CAUTION: Use of excessive contrast media may lead to renal failure. Measure the patient’s creatinine level prior to the procedure. Contrast media usage should be monitored.

CAUTION: Procedure may require an arterial cut-down with surgical closure of the puncture site due to the size of the arteriotomy.

7.3.1 Baseline Parameters

Step	Procedure
1	Perform a supra-aortic angiogram with fluoroscopic view perpendicular to the aortic valve.
2	Evaluate the distance of the left and right coronary ostia from the aortic annulus in relation to the THV frame height.
3	Introduce a pacemaker (PM) lead until its distal end is positioned in the right ventricle.
4	Set the stimulation parameters to obtain 1:1 capture, and test pacing.

7.3.2 Valvuloplasty

Refer to Edwards Balloon Catheter Instructions for Use (IFU) for information on device preparation and handling.

Note: Rapid ventricular pacing should be performed when using the Edwards Balloon Catheter for valvuloplasty prior to aortic transcatheter valve implantation.

After placement of the balloon at the intended site, begin rapid ventricular pacing. Once the systolic blood pressure has decreased to 50 mmHg or below, balloon inflation can commence.

CAUTION: THV implantation should not be carried out if the balloon cannot be fully inflated during valvuloplasty.

7.3.3 THV Delivery

Step	Procedure
1	Prepare and insert the Edwards eSheath Introducer Set. Refer to the Edwards eSheath Introducer Set IFU for information on device preparation and handling.
2	Insert the loader into the sheath until the loader stops.
3	<p>Advance the Edwards Commander delivery system, with the Edwards logo facing up, through the sheath until the THV exits the sheath. Retract the loader to the proximal end of the delivery system.</p> <p>NOTE: Maintain the proper orientation of the flex catheter (with the Edwards logo facing up) throughout the procedure.</p> <p>CAUTION: If accessing femorally or via the iliac, the THV should not be advanced through the sheath if the sheath tip is not past the aortic bifurcation.</p> <p>CAUTION: To prevent possible leaflet damage, the THV should not remain in the sheath for over 5 minutes.</p>

Step	Procedure
4	<p>In a straight section of the aorta, initiate valve alignment by disengaging the Balloon Lock and pulling the balloon catheter straight back until part of the Warning Marker is visible. Do not pull past the Warning Marker.</p> <p>WARNING: To prevent possible damage to the balloon shaft, ensure that the proximal end of the balloon shaft is not subjected to bending.</p> <p>Engage the Balloon Lock.</p> <p>Use the Fine Adjustment Wheel to position the THV between the valve alignment markers.</p> <p>CAUTION: Do not turn the Fine Adjustment Wheel if the Balloon Lock is not engaged.</p> <p>WARNING: Do not position the THV past the distal Valve Alignment Marker. This will prevent proper valve deployment.</p> <p>CAUTION: Maintain guidewire position in the left ventricle during valve alignment.</p>
5	<p>Advance the catheter and use the flex wheel, if needed, and cross the aortic valve.</p> <p>NOTE: Verify the Edwards logo is facing up. The delivery system articulates in a direction opposite from the flush port.</p>
6	<p>If additional working length is needed, remove the loader by unscrewing the loader cap and peeling the loader tubing from the delivery system.</p>
7	<p>Disengage the Balloon Lock and retract the tip of the Flex Catheter to the center of the Triple Marker.</p> <p>Engage the Balloon Lock.</p>
8	<p>Verify the correct position of the THV with respect to the aortic annulus.</p>
9	<p>As necessary, utilize the Flex Wheel to adjust the co-axiality of the THV and the Fine Adjustment Wheel to adjust the position of the THV.</p>
10	<p>Before deployment, ensure that the THV is correctly positioned between the Valve Alignment Markers and the Flex Catheter tip is over the Triple Marker.</p>
11	<p>Begin THV deployment:</p> <ul style="list-style-type: none"> • Unlock the Inflation device provided by Edwards Lifesciences. • Begin rapid pacing; once systolic blood pressure has decreased to 50 mmHg or below, balloon inflation can commence. • Deploy the THV by inflating the balloon with the entire volume in the Inflation device provided by Edwards Lifesciences, hold for 3 seconds and confirm that the barrel of the inflation device is empty to ensure complete inflation of the balloon. • Deflate the balloon. When the balloon catheter has been completely deflated, turn off the pacemaker.

7.3.4 System Removal

Step	Procedure
1	<p>Unflex the delivery system while retracting the device, if needed. Verify that the Flex Catheter tip is locked over the Triple Marker and remove the delivery system from the sheath.</p> <p>CAUTION: Patient injury could occur if the delivery system is not unflexed prior to removal.</p>
2	<p>Remove all devices when the ACT level is appropriate. Refer to the Edwards Expandable Introducer Sheath Set instructions for use for device removal.</p>
3	<p>Close the access site.</p>

8.0 How Supplied

STERILE: The THV is supplied sterilized with glutaraldehyde solution. The delivery system is supplied sterilized with ethylene oxide gas.

8.1 Storage

The THV must be stored at 10 °C to 25 °C (50 °F to 77 °F). Each jar is shipped in an enclosure containing a temperature indicator to detect exposure of the THV to extreme temperature.

The delivery system should be stored in a cool, dry place.

9.0 MR Safety



MR Conditional

The Edwards SAPIEN 3 transcatheter heart valve has been determined to be MR Conditional. A patient with this device can be safely scanned in an MR system meeting the following conditions:

- Static magnetic field of 1.5 tesla or 3 tesla.
- Maximum spatial gradient field of 2500 gauss/cm (25 T/m) or less.
- Maximum MR system reported, whole body averaged specific absorption rate (SAR) of 2 W/kg (Normal Operating Mode)

Under the scan conditions defined above, the SAPIEN 3 transcatheter heart valve is expected to produce a maximum temperature rise of 3.0 °C after 15 minutes of continuous scanning.

In non-clinical testing, the image artifact caused by the device extends as far as 10 mm from the implant for spin echo images and 30 mm for gradient echo images when scanned in a 3.0T MRI system.

The implant has not been evaluated in MR systems other than 1.5 or 3.0T.

10.0 Patient Information

Patient education brochures are provided to each site and should be given to the patient to inform them of the risks and benefits of the procedure and alternatives in adequate time before the procedure to be read and discussed with their physician. A copy of this brochure may also be obtained from Edwards Lifesciences by calling 1.800.822.9837. A patient implant card request form is provided with each transcatheter heart valve. After implantation, all requested information should be completed on this form. The serial number may be found on the package and on the identification tag attached to the transcatheter heart valve. The original form should be returned to the Edwards Lifesciences address indicated on the form and upon receipt, Edwards Lifesciences will provide an identification card to the patient.

11.0 Recovered THV and Device Disposal

The explanted THV should be placed into a suitable histological fixative such as 10% formalin or 2% glutaraldehyde and returned to the company. Refrigeration is not necessary under these circumstances. Contact Edwards Lifesciences to request an Explant Kit.

Used delivery system may be disposed of in the same manner that hospital waste and biohazardous materials are handled. There are no special risks related to the disposal of these devices.

12.0 Clinical Studies

SUMMARY OF PRIMARY CLINICAL STUDY

Primary Clinical Study Design

The PIIS3HR Cohort of the PARTNER II trial was a single arm, non-randomized, historical-controlled study to compare the third generation Edwards SAPIEN 3 THV system with the first generation Edwards SAPIEN THV system in patients who either have high risk for surgery or cannot undergo surgery (inoperable). The valve sizes used in the PIIS3HR trial included only the 23, 26 and 29 mm sizes. The 20 mm valve size was introduced into the trial after enrollment was completed with the three larger sizes, thus a separate nested registry, NR7, with identical inclusion/exclusion criteria as the PIIS3HR Cohort except for the aortic annulus diameter, was created to collect data for the 20 mm valve. Data from the PIIS3HR cohort and NR7 are pooled for the statistical analyses. For convenience, this combined cohort is referred to as "PIIS3HR" hereafter.

The database included 583 eligible patients enrolled at 29 investigational sites in the U.S.

The study used an independent Data Safety Monitoring Board (DSMB) that was instructed to notify Edwards Lifesciences of any safety or compliance issues, a Clinical Events Committee (CEC) that was responsible for adjudicating endpoint related events reported during the trial per *a priori* established

VARC 2 definitions,^[1] an ECG core laboratory for independent analysis of rhythm, and an echocardiographic core laboratory for independently analyzing all echocardiograms.

Accountability

All 583 eligible patients were successfully implanted with a SAPIEN 3 THV, which constitutes the Valve Implant (VI) population. Among the VI population, 491 patients were implanted via the transfemoral (TF) access route, and 92 patients via the transapical (TA) or transaortic (TAo) access route.

Table 5: Patient Accountability

	Overall	TF	TA /TAo
Eligible Patient Population (EPP)	583	491	92
Valve Implant (VI) Population	583	491	92

Eligible Patient Population (EPP) consists of all enrolled patients who received treatment assignment from the database and entered into the catheterization laboratory/hybrid suite and who remained eligible to receive the implant.

Valve Implant (VI) Population consists of all enrolled patients who received a SAPIEN 3 implant, and retained the valve upon leaving the catheterization laboratory/hybrid suite.

Study Population Demographics and Baseline Parameters

The demographics of the study population are summarized in Table 6, which are typical of a TAVR study performed in the U.S.

Table 6: Patient Demographics and Baseline Characteristics - PIIS3HR VI Population

Characteristic	Overall (N= 583)	TF (N= 491)	TA/TAo (N= 92)
Age, yr	82.6 ± 8.1	82.8 ± 8.2	81.7 ± 7.5
Male sex, no. (%)	338 (58.0%)	277 (56.4%)	61 (66.3%)
STS score	8.6 ± 3.7	8.4 ± 3.5	10.0 ± 4.3
New York Heart Association (NYHA) class, no. (%):			
I/II	58 (9.9%)	51 (10.4%)	7 (7.6%)
III/IV	525 (90.1%)	440 (89.6%)	85 (92.4%)
Coronary artery disease, no. (%)	444 (76.2%)	360 (73.3%)	84 (91.3%)
Previous myocardial infarction, no. (%)	117 (20.1%)	87 (17.7%)	30 (32.6%)
Previous intervention, no. (%)			
Coronary-artery bypass grafting (CABG)	193 (33.1%)	145 (29.5%)	48 (52.2%)
Percutaneous coronary intervention (PCI)	199 (34.1%)	163 (33.2%)	36 (39.1%)
Prior aortic valvuloplasty	62 (10.6%)	49 (10.0%)	13 (14.1%)
Cerebral vascular accident (CVA), no. (%)	64 (11.0%)	53 (10.8%)	11 (12.0%)
Peripheral vascular disease, no. (%)	205 (35.2%)	155 (31.6%)	50 (54.3%)
Chronic obstructive pulmonary disease (COPD), no. (%):			
Any	259 (44.6%)	216 (44.1%)	43 (47.3%)
Oxygen-dependent	68 (11.8%)	58 (11.9%)	10 (11.0%)
Atrial fibrillation, no. (%)	255 (43.7%)	212 (43.2%)	43 (46.7%)
Permanent pacemaker, no. (%)	95 (16.3%)	78 (15.9%)	17 (18.5%)
Severe pulmonary hypertension, no. (%)	30 (5.1%)	24 (4.9%)	6 (6.5%)
Frailty, no. (%)	180 (30.9%)	162 (33.0%)	18 (19.6%)
Chest deformities that preclude an open chest procedure, no. (%)	4 (0.7%)	3 (0.6%)	1 (1.1%)
Cirrhosis, no. (%)	11 (1.9%)	9 (1.8%)	2 (2.2%)

Characteristic	Overall (N= 583)	TF (N= 491)	TATaO (N= 92)
Echocardiographic findings			
Effective Orifice Area (EOA), cm ²	0.7 ± 0.2	0.7 ± 0.2	0.7 ± 0.1
Mean aortic-valve gradient, mmHg	45.5 ± 14.3	45.7 ± 14.4	44.0 ± 13.2
Mean left ventricular ejection fraction (LVEF), %	56.4 ± 14.8	57.0 ± 14.5	53.2 ± 15.9
Moderate or severe mitral regurgitation, no./total no. (%)	69/541 (12.8%)	63/461 (13.7%)	6/80 (7.5%)

Safety and Effectiveness Results

Primary Endpoint

The composite rate of all-cause mortality, all stroke, and AI ≥ moderate at 30 days was 6.7% in the SAPIEN 3 cohort and 15.6% in the SAPIEN cohort, as shown in Table 7. The resulting proportion difference in the average treatment effect on the treated (ATT; [2]) was -6.9% (90% CI: [-13.3%, -0.5%]). Since the upper limit of the CI was < 7.5%, the non-inferiority was met.

Table 7: Primary Endpoint Analysis – Non-Inferiority Test SAPIEN 3 (PIIS3HR VI Population) vs. SAPIEN

Event at 30 days	SAPIEN 3 (N=583)	SAPIEN (N=326)	Weighted Proportion Difference in Average Treatment Effect on the Treated (ATT)
Composite of Death, Stroke and AI ≥ Moderate)	6.7% [5.1%, 8.6%] ¹	15.6% [12.6%, 19.5%] ¹	-6.9% [-13.3%, -0.5%] ²
¹ For each individual study, the two-sided 90% stratified Wilson confidence interval was provided.			
² The Wald-type two-sided 90% confidence interval using weighted mean and SD is provided			

The Kaplan-Meier (K-M) estimates for all-cause mortality, cardiac mortality, and all stroke at 30 days for the SAPIEN 3 cohort and the SAPIEN cohort are provided in Table 8.

Table 8: Death and Stroke at 30 Days – SAPIEN 3 vs. SAPIEN (VI Population)

Event at 30 Days	SAPIEN 3 (N= 583)			SAPIEN (N= 326)		
	No. Events	No. Pts with Events	K-M Estimated Event Rate ¹ (95% CI)	No. Events	No. Pts with Events	K-M Estimated Event Rate (95% CI)
Death	13	13	2.2% ([1.3%, 3.8%])	15	15	4.6% ([2.8%, 7.5%])
Cardiac Death	8	8	1.4% ([0.7%, 2.7%])	10	10	3.1% ([1.7%, 5.7%])
All Stroke	9	9	1.6% ([0.8%, 3.0%])	14	14	4.3% ([2.6%, 7.2%])
¹ Kaplan-Meier (K-M) estimates at 30 days used time to first event for each patient. Events occurring after 30 days were not included in this analysis.						

Secondary Endpoints

Aortic insufficiency by visit is provided in Figure 4.

Figure 4: Aortic Insufficiency by Visit – SAPIEN 3 (PIIS3HR VI Population) vs. SAPIEN

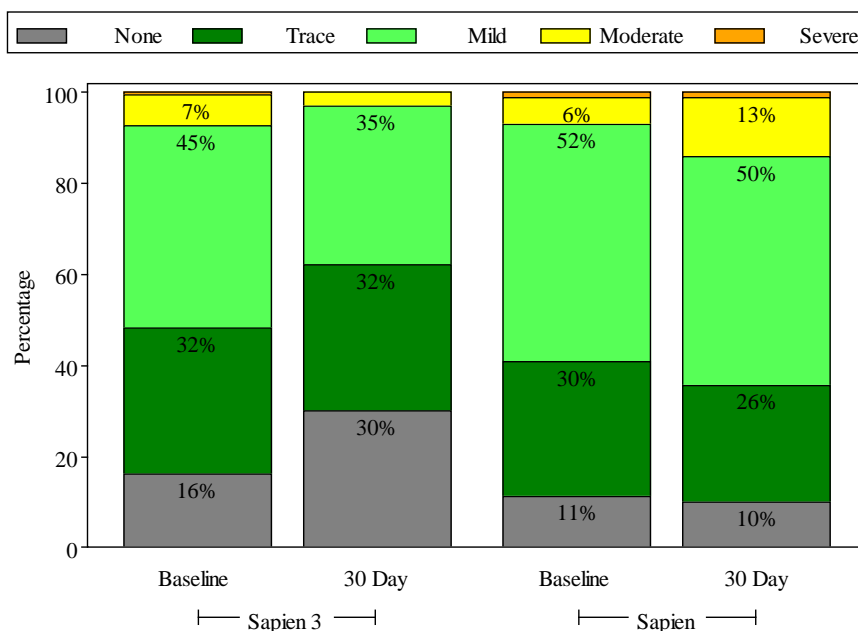

The proportion of patients with AI \geq moderate at 30 days was 3.0% in the SAPIEN 3 cohort and 14.3% in the SAPIEN cohort, which were found to be statistically significantly different ($p=0.0051$; Table 9).

Table 9: Aortic Insufficiency at 30 Days (SAPIEN 3 vs. SAPIEN VI Population)

Event at 30 Days	SAPIEN 3 (N = 583)	SAPIEN (N = 326)	Weighted Proportion Difference in Average Treatment Effect on the Treated (ATT)	P-value
AI \geq Moderate, n/Total no. (%) [95% CI]	16/532 (3.0%) [1.7%, 4.8%] ¹	40/280 (14.3%) [10.4%, 18.9%] ¹	-13.1% [-22.2%, -3.9%] ²	0.0051

¹95% Clopper-Pearson Exact confidence interval.

²The Wald-type two-sided 90% confidence interval using weighted mean and SD is provided

The rate of major vascular complications at 30 days post implantation is shown in Figure 5. The rate was 5.0% for the SAPIEN 3 cohort and 10.1% for the SAPIEN cohort, which were found to be not statistically significantly different ($p=0.0578$; Table 10).

Figure 5: Major Vascular Complications at 30 Days – SAPIEN 3 vs. SAPIEN (VI Population)

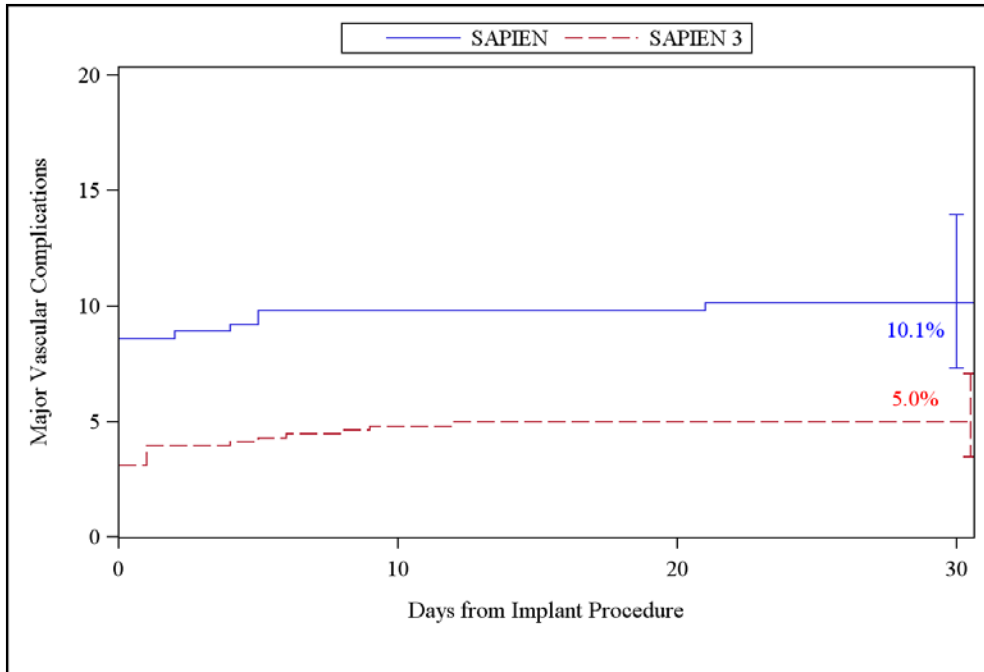

Table 10: Major Vascular Complications at 30 Days – SAPIEN 3 vs. SAPIEN (VI Population)

Event at 30 Day	SAPIEN 3 (N=583)	SAPIEN (N=326)	Weighted Proportion Difference in Average Treatment Effect on the Treated (ATT)	P-value
Major Vascular Complications, n/Total no. (%) [95% CI]	29/583 (5.0%) [3.4% , 7.1%]	33/326 (10.1%) [7.1% , 13.9%] ¹	-8.0% [-16.2%, 0.3%] ²	0.0578

¹ 95% Clopper-Pearson Exact confidence interval.

² The Wald-type two-sided 90% confidence interval using weighted mean and SD is provided.

Table 11 lists the hypothesis testing of the two secondary endpoints conducted with p-values in descending order for the Hochberg multiplicity adjustment steps. The largest p-value ($p=0.0578$ from major vascular complications) was greater than 0.05. As such, the null hypothesis was not rejected for the testing of major vascular complications at 30 days. The subsequent testing of AI \geq moderate at 30 days had a p-value of 0.0051, which was less than 0.025. As such, the null hypothesis was rejected for AI \geq moderate at 30 days, indicating that SAPIEN 3 was superior over SAPIEN in regards to AI \geq moderate at 30 days.

Table 11: Secondary Endpoints for Labeling – SAPIEN 3 vs. SAPIEN (VI Population)

Endpoints	Original p-value	Inference
Major Vascular Complications at 30 Days	0.0578	> 0.05; reject the alternative hypothesis. Proceed to the rest of testing
AI at 30 Days	0.0051	< 0.025; claim superiority

Adverse Events

The key CEC adjudicated adverse events at 30 days are presented in Table 12.

Table 12: CEC Adjudicated Adverse Events at 30 Days (PIIS3HR VI Population)

30 Day Adverse Events	Overall	TF	TA/TAo
Composite Event Rate of Death, All Stroke and AI \geq Moderate, n/N (%)	37/545 (6.8 %)	27/463 (5.8 %)	10/82 (12.2 %)
Death			
From Any cause, n/N (%)	13/583 (2.2%)	8/491 (1.6%)	5/92 (5.4%)
From cardiovascular cause, n/N (%)	8/583 (1.4%)	5/491 (1.0%)	3/92 (3.3%)
Stroke, n/N (%)	9/583 (1.5%)	8/491 (1.6%)	1/92 (1.1%)
AI \geq moderate, n/N (%)	16/532 (3.0 %)	12/455 (2.6 %)	4 /77 (5.2 %)
Myocardial Infarction, n/N (%)	3/583 (0.5%)	2/491 (0.4%)	1/92 (1.1%)
Major Vascular Complications, n/N (%)	29/583 (5.0%)	26/491 (5.3%)	3/92 (3.3%)
Acute Kidney Injury, Stage III, n/N (%)	6/583 (1.0%)	4/491 (0.8%)	2/92 (2.2%)
Disabling Bleeding Event, n/N (%)	37/583 (6.3%)	27/491 (5.5%)	10/92 (10.9%)
Aortic Valve Re-Intervention, n/N (%)	6/583 (1.0%)	4/491 (0.8%)	2/92 (2.2%)
Endocarditis, n/N (%)	1/583 (0.2%)	1/491 (0.2%)	0/92 (0.0%)
Conduction Disturbance Requiring Permanent Pacemaker, n/N (%)	76/583 (13.0%)	65/ 491 (13.2%)	11/ 92 (12.0%)

Other Results

Procedural Information

Overall, the mean duration in the catheterization laboratory/hybrid suite was 192.8 ± 59.3 min, the mean total procedure time was 86.3 ± 44.2 min, and the mean total anesthesia time was 193.7 ± 62.9 min. These duration times were slightly shorter in the TF group. General anesthesia was used in the vast majority of cases; 15.9% of the TF patients had conscious sedation. Correct positioning of the valve was achieved in 99.1% of the patients. Five patients (0.9%; including 3 TF patients) were implanted with a second valve. One patient (0.2%) experienced valve embolization following rupture of the delivery balloon on annular calcium. This patient was converted to surgical aortic valve replacement and later died from aortic dissection.

Valve Performance

The mean EOA increased from $0.7 \pm 0.2 \text{ cm}^2$ at baseline to $1.6 \pm 0.4 \text{ cm}^2$ at 30 days, as shown in Figure 6.

Figure 6: Effective Orifice Area (PIIS3HR VI Population)

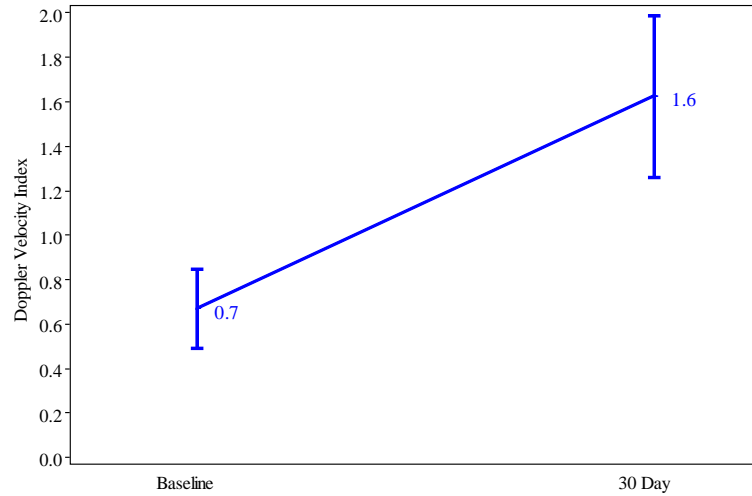

The average mean gradient decreased from $45.5 \pm 14.3 \text{ mmHg}$ at baseline to $11.1 \pm 4.5 \text{ mmHg}$ at 30 days, as shown in Figure 7.

Figure 7: Mean Gradient (PIIS3HR VI Population)

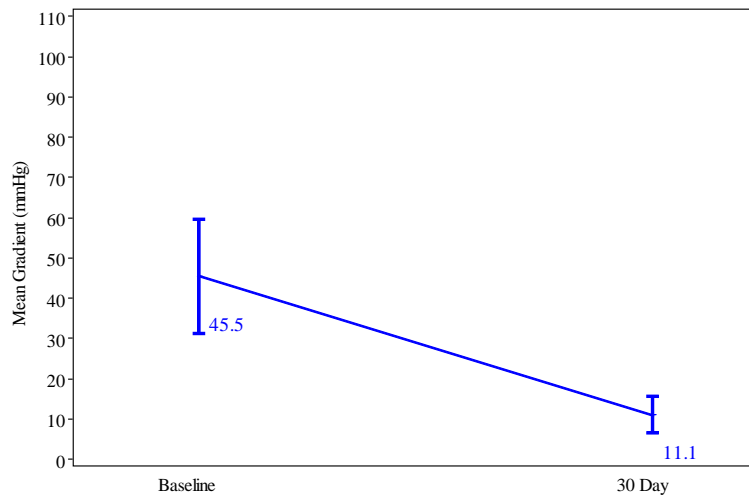

The mean peak gradient decreased from 75.8 ± 22.6 mmHg at baseline to 21.2 ± 8.5 mmHg at 30 days, as shown in Figure 8.

Figure 8: Peak Gradient (PIIS3HR VI Population)

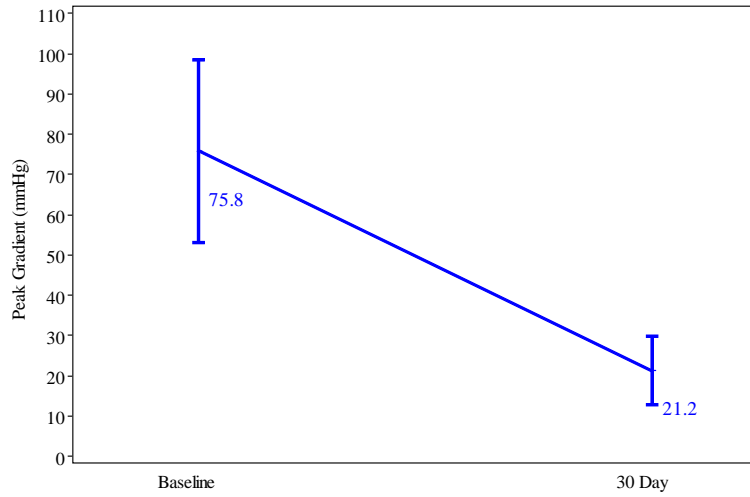

The proportion of patients with AI \geq moderate was 7.3% at baseline and 3.0% at 30 days, as shown in Figure 9.

Figure 9: Aortic Insufficiency (PIIS3HR VI Population)

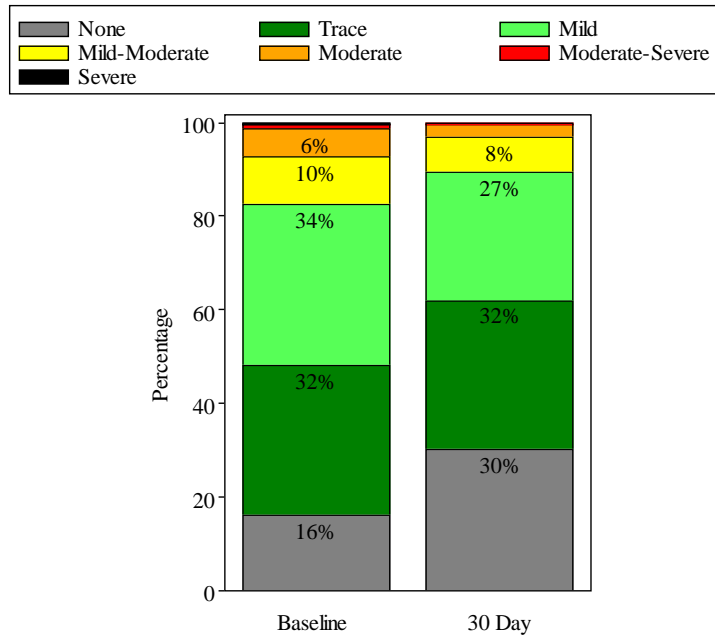

The proportion of patients with aortic paravalvular leak (PVL) \geq moderate was 2.9% at 30 days, as shown in Figure 10.

Figure 10: Aortic Paravalvular Leak (PIIS3HR VI Population)

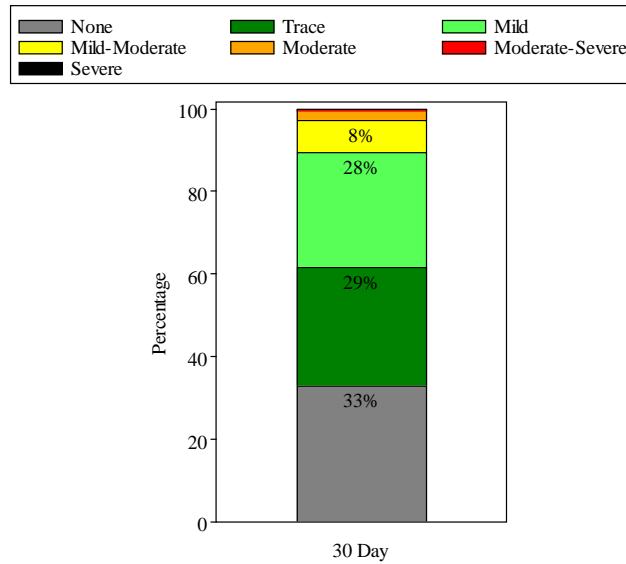

NYHA

The NYHA class by visit is shown in Figure 11. For all patients, the mean NYHA class was 3.2 ± 0.6 at baseline and 1.7 ± 0.7 at 30 days.

Figure 11: NYHA Class by Visit (PIIS3HR VI Population)

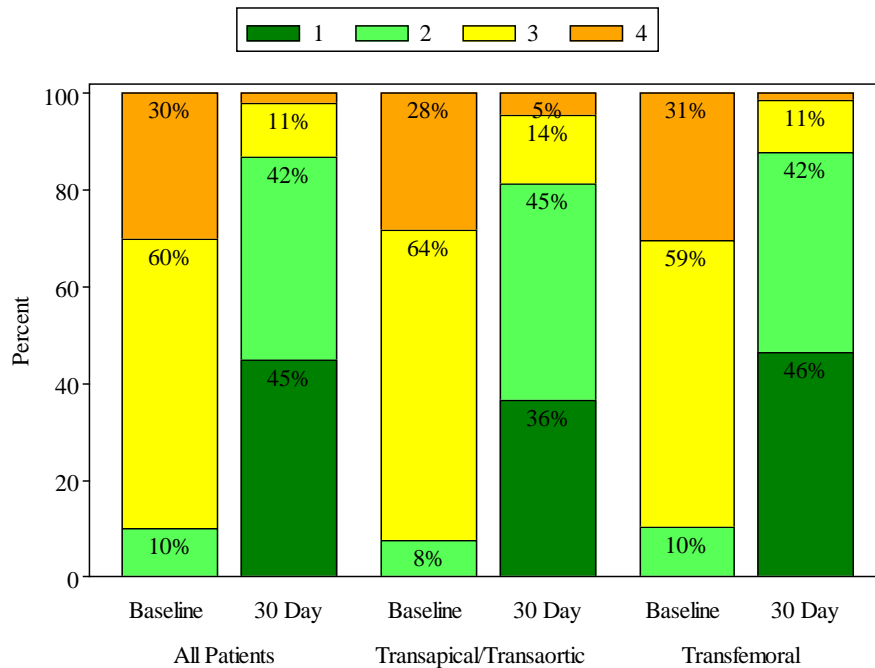

Six Minute Walk Test (6MWT)

The improvement in mean 6MWT distance was 38.5 ± 110.2 meters from baseline to 30 days for all patients, 42.6 ± 107.8 meters for all TF patients, and 15.9 ± 121.2 meters for all TA/TAo patients.

Length of Stay (LoS)

The overall mean LoS was 6.8 ± 4.8 days, which included 3.0 ± 2.7 days in the ICU. The mean LoS was 6.1 ± 4.3 days (including 2.7 ± 2.3 days in the ICU) for the TF patients and 10.4 ± 5.4 days (including 4.8 ± 3.9 days in the ICU) for the TA/TAo patients.

Quality of Life (QoL)

QoL was measured using the visual analog scale (VAS) of the EuroQoL (EQ-5D) measure. The VAS is a self-assessment in which patients rate their well-being on a scale from 0 to 100 where 0 is the worst state they can imagine and 100 is the best state. During the trial, the mean improvement in VAS scale from baseline to 30 days was 14.6 ± 22.2 for all patients, 15.1 ± 21.5 for the TF patients, and 11.5 ± 25.7 for the TA/TAo patients.

Additional QoL instruments

The mean overall Kansas City Cardiomyopathy Questionnaire (KCCQ) summary score was 46.9 ± 22.6 at baseline, and 67.5 ± 22.6 at 30 days for the entire VI population. Except for self-efficacy which showed a small improvement, moderate to large improvements were observed in all other subscores at 30 days. In general, improvements in the TF group were slightly larger compared to those observed in the TA/TAo group.

Using the SF-36 norm based questionnaire, the physical component score for all patients improved from 32.0 ± 8.9 at baseline to 37.1 ± 9.7 at 30 days, and the mental component score improved from 46.9 ± 12.8 at baseline to 50.0 ± 12.5 at 30 days. In the TF group, the physical component score improved from 31.8 ± 8.7 at baseline to 37.3 ± 9.8 at 30 days, and the mental component score improved from 46.8 ± 13.1 at baseline to 50.5 ± 12.2 at 30 days. In the TA/TAo group, the physical component score improved from 32.9 ± 10.0 at baseline to 35.9 ± 9.4 at 30 days, and the mental component scores were 47.2 ± 11.1 at baseline and 47.2 ± 14.0 at 30 days.

SUMMARY OF SUPPLEMENTAL CLINICAL INFORMATION

Supplemental Clinical Study Design

Supplemental clinical data came from a study (referred to as “S3OUS” hereafter) conducted in Europe and Canada.

The S3OUS study was a non-randomized, prospective, multi-center study in inoperable, high surgical risk, and intermediate surgical risk patients who underwent implantation of the 23, 26, or 29 mm SAPIEN 3 THV.

Except the intermediate surgical risk patients, the inclusion/exclusion criteria of the S3OUS trial were largely similar to those of the PIIS3HR trial. The S3OUS study had a minimum age requirement (≥ 75 years) and the upper limit for AVA was higher ($< 1 \text{ cm}^2$ instead of $\leq 0.80 \text{ cm}^2$). Additionally, the S3OUS study included BAV within 30 days of the procedure (unless BAV was a bridge to procedure), patients with planned concomitant surgical or transcatheter ablation for atrial fibrillation, hemodynamic or respiratory instability requiring inotropic support, mechanical ventilation or mechanical heart assistance within 30 days of screening; and the need for emergency surgery for any reason. Furthermore, the exclusion criteria in the S3OUS study excluded senile dementia and any neurologic disease which severely affected the ability to walk or perform everyday activities, and shortened the time interval regarding confirmed stroke or TIA (within 3 months instead of 6 month of the procedure). The follow-up periods were discharge or 7 days, whichever comes first, 30 days, 1 year, and annually thereafter to a minimum of 5 years post procedure.

Accountability of the S3OUS Cohort

Patients were treated at 14 investigational sites. Note that the intermediate risk patients enrolled in the S3OUS study were excluded from the analysis presented herein. The database included 102 “all treated” (AT) inoperable and high surgical risk patients. “All treated” population is defined to include all patients who were enrolled in the trial and for whom the study valve implantation procedures were started (i.e., the anesthesia was started).

One patient was excluded from the VI population. This patient experienced an aortic root rupture caused by displacement of a large lump of calcium with sharp edges through the native aortic annulus following balloon expansion of the SAPIEN 3 THV. The patient was subsequently converted to SAVR. After the patient was weaned off cardio-pulmonary bypass, bleeding in the region of the dorsal root occurred, and the patient died on the operating table.

A total of 56 patients were successfully implanted with a SAPIEN 3 THV via the transfemoral access route, and 45 via the transapical/transaortic access route, as shown in Table 13.

Table 13: Patient Accountability (S3OUS)

Overall		TF		TA/TAo	
All Treated (AT) Population	Valve Implant (VI) Population	All Treated (AT) Population	Valve Implant (VI) Population	All Treated (AT) Population	Valve Implant (VI) Population
102	101	57	56	45	45
All Treated (AT) Population consists of all patients who were enrolled in the trial and for whom the study valve implantation procedures were started (i.e., anesthesia was started).					
Valve Implant (VI) Population consists of all enrolled patients who received a SAPIEN 3 implant, and retained the valve upon leaving the catheterization laboratory/hybrid suite.					

Study Population Demographics and Baseline Parameters

The demographics of the S3OUS study population are shown in Table 14.

Table 14: Patient Demographics and Baseline Characteristics (S3OUS AT Population)

Demographics and Baseline Characteristics	Overall (N= 102)	TF (N= 57)	TA/TAo (N= 45)
Age, yr	84.1 ± 5.0	85.1 ± 4.6	83.0 ± 5.3
Male sex, no.(%)	40 (39.2%)	23 (40.4%)	17 (37.8%)
STS score	8.0 ± 4.7	8.2 ± 4.2	7.9 ± 5.2
Logistic EuroSCORE	24.1 ± 13.0	22.3 ± 11.3	26.4 ± 14.7
New York Heart Association (NYHA) class, no.(%):			
I/II	11 (10.8%)	6 (10.5%)	5 (11.1%)
III/IV	91 (89.2%)	51 (89.5%)	40 (88.9%)
Coronary artery disease, no.(%)	68 (66.7%)	36 (63.2%)	32 (71.1%)
Previous myocardial infarction, no.(%)	20 (19.6%)	7 (12.3%)	13 (28.9%)
Previous intervention, no.(%)			
Coronary-artery bypass grafting (CABG)	24 (23.5%)	10 (17.5%)	14 (31.1%)
Percutaneous coronary intervention (PCI)	34 (33.3%)	16 (28.1%)	18 (40.0%)
Prior aortic valvuloplasty	10 (9.8%)	8 (14.0%)	2 (4.4%)
Stroke, no.(%)	7 (6.9%)	4 (7.0%)	3 (6.7%)
Peripheral vascular disease, no.(%)	27 (26.5%)	10 (17.5%)	17 (37.8%)
Chronic obstructive pulmonary disease (COPD), no.(%):			
Any	25 (24.5%)	13 (22.8%)	12 (26.7%)
Oxygen-dependent	1 (1.0%)	1 (1.8%)	0 (0%)
Atrial fibrillation, no.(%)	48 (47.1%)	22 (38.6%)	26 (57.8%)

Demographics and Baseline Characteristics	Overall (N= 102)	TF (N= 57)	T/TAo (N= 45)
Permanent pacemaker, no.(%)	15 (14.7%)	7 (12.3%)	8 (17.8%)
Severe pulmonary hypertension, no.(%)	10 (9.8%)	6 (10.5%)	4 (8.9%)
Severe liver disease / Cirrhosis, no.(%)	1 (1.0%)	1 (1.8%)	0 (0%)
Echocardiographic findings			
Effective Orifice Area (EOA), cm ²	0.6 ± 0.2	0.6 ± 0.2	0.6 ± 0.1
Mean aortic-valve gradient, mmHg	44.8 ± 15.3	45.2 ± 14.7	44.2 ± 16.1
Mean left ventricular ejection fraction (LVEF), %	56.7 ± 9.1	57.7 ± 9.3	55.3 ± 8.7
Moderate or severe mitral regurgitation, no./total no. (%)	23/85 (27.1%)	9/48 (18.8%)	14/37 (37.8%)

Plus-minus values are means ± SD.

Safety and Effectiveness Results

Key Adverse Events

Key adverse events as adjudicated by the CEC are presented in Table 15.

Table 15: CEC Adjudicated Adverse Events at 1 Year (S3OUS AT Population)

Outcomes	30 Day			1 Year		
	Overall	TF	T/TAo	Overall	TF	T/TAo
Composite Event Rate of Death, All Stroke and AI ≥ Moderate, n/N (%)	13/88 (14.8%)	3/50 (6.0%)	10/38 (26.3%)	25/82 (30.5%)	9/47 (19.1%)	16/35 (45.7%)
Death						
From any death, n/N (%)	8/102 (7.8%)	2/57 (3.5%)	6/45 (13.3%)	20/102 (19.6%)	7/57 (12.3%)	13/45 (28.9%)
From cardiovascular cause, n/N (%)	7/102 (6.9%)	2/57 (3.5%)	5/45 (11.1%)	9/102 (8.8%)	2/57 (3.5%)	7/45 (15.6%)
Stroke, n/N (%)	3/102 (2.9%)	1/57 (1.8%)	2/45 (4.4%)	5/102 (4.9%)	2/57 (3.5%)	3/45 (6.7%)
Aortic Insufficiency (AI) ≥ Moderate, n/N (%)	3/81 (3.7%)	1/49 (2.0%)	2/32 (6.3%)	1/62 (1.6%)	1/40 (2.5%)	0/22 (0.0%)
Disabling Stroke, n/N (%)	0/102 (0.0%)	0/57 (0.0%)	0/45 (0.0%)	1/102 (1.0%)	1/57 (1.8%)	0/45 (0.0%)
Myocardial Infarction, n/N (%)	2/102 (2.0%)	2/57 (3.5%)	0/45 (0.0%)	3/102 (2.9%)	2/57 (3.5%)	1/45 (2.2%)
Major Vascular Complications, n/N (%)	5/102 (4.9%)	1/57 (1.8%)	4/45 (8.9%)	N/A	N/A	N/A
Acute Kidney Injury - Stage III, n/N (%)	0/102 (0.0%)	0/57 (0.0%)	0/45 (0.0%)	N/A	N/A	N/A
Disabling Bleeding Event, n/N (%)	6/102 (5.9%)	3/57 (5.3%)	3/45 (6.7%)	N/A	N/A	N/A
THV Dysfunction Requiring Intervention, n/N (%)	0/102 (0.0%)	0/57 (0.0%)	0/45 (0.0%)	N/A	N/A	N/A
Prosthetic Valve Endocarditis, n/N (%)	0/102 (0.0%)	0/57 (0.0%)	0/45 (0.0%)	1/102 (1.0%)	0/57 (0.0%)	1/45 (2.2%)
Conduction Abnormality Requiring Pacemaker, n/N (%)	14/102 (13.7%)	7/57 (12.3%)	7/45 (15.6%)	14/102 (13.7%)	7/57 (12.3%)	7/45 (15.6%)

The composite adverse event rate involving all-cause mortality, all stroke, and AI ≥ moderate at 30 days for all patients is higher in the S3OUS cohort than PIIS3HR cohort (14.8% vs. 6.8%). This disparity is due to the composition of the study populations, specifically the S3OUS cohort comprises 44.1% T/TAo patients vs. 15.8% T/TAo patients in the PIIS3HR cohort. Note, the

composite adverse event rate at 30 days for TF patients was similar, specifically, 6.0% in the S3OUS cohort and 5.8% in the PIIS3HR cohort.

The K-M estimates for all-cause mortality for all patients, the TF patients, and the TA/TAo patients are shown in Figure 12.

Figure 12: All-Cause Mortality at 1 Year (S3OUS AT Population)

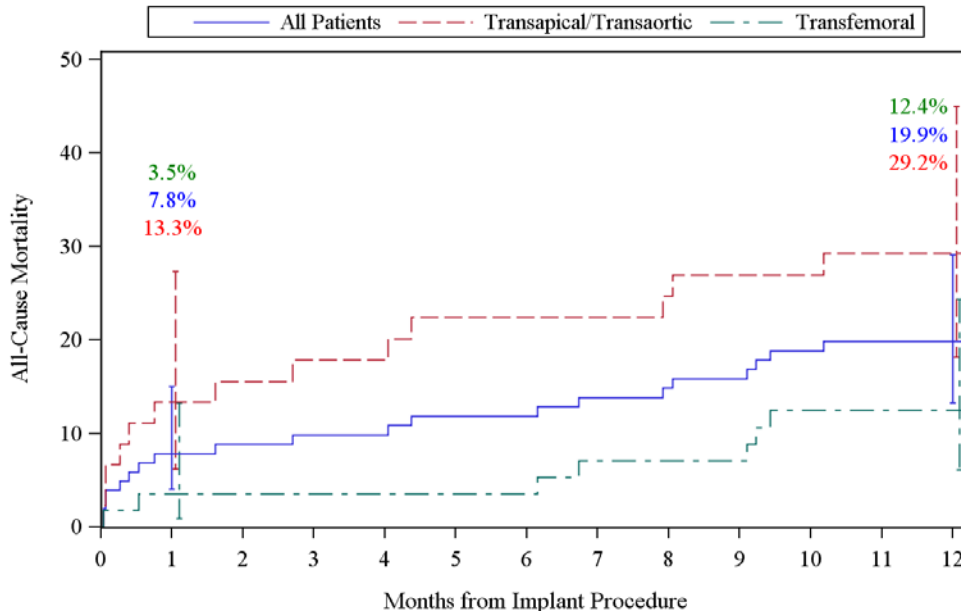

Note: The confidence intervals are calculated without multiplicity adjustment. The adjusted confidence intervals could be wider than presented here. As such, confidence intervals are provided to illustrate the variability only and should not be used to draw any statistical conclusion.

The K-M estimates for the stroke rate for all patients, the TF patients, and the TA/TAo patients are shown in Figure 13.

Figure 13: All Stroke at 1 Year (S3OUS AT Population)

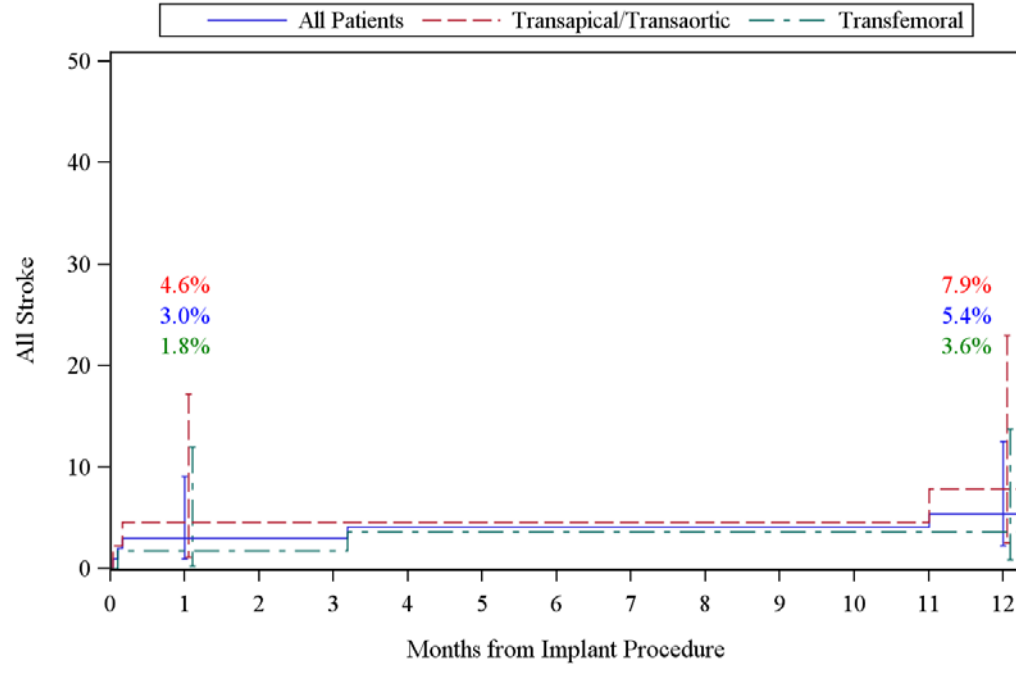

Note: The confidence intervals are calculated without multiplicity adjustment. The adjusted confidence intervals could be wider than presented here. As such, confidence intervals are provided to illustrate the variability only and should not be used to draw any statistical conclusion.

Valve Performance

The mean EOA increased from $0.6 \pm 0.2 \text{ cm}^2$ at baseline to $1.5 \pm 0.4 \text{ cm}^2$ at 30 days and $1.4 \pm 0.4 \text{ cm}^2$ at 1 year, as shown in Figure 14.

Figure 14: Effective Orifice Area (S3OUS VI Population)

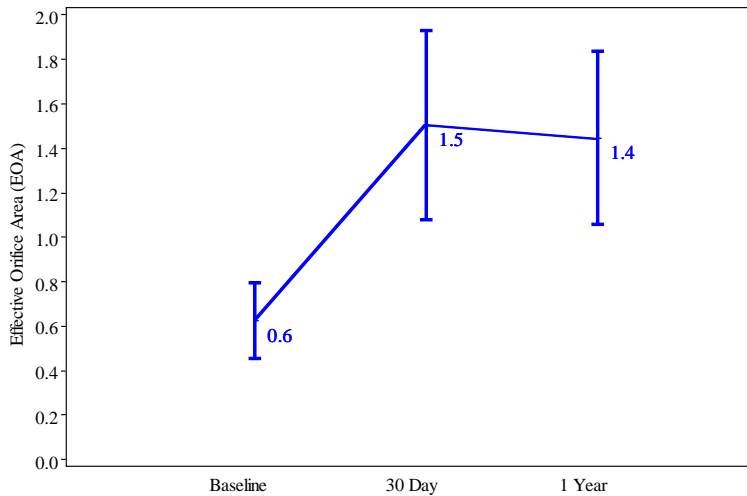

The average mean gradient decreased from 44.8 ± 15.4 mmHg at baseline to 10.4 ± 4.1 mmHg at 30 days and maintained at 10.7 ± 4.1 mmHg at 1 year, as shown in Figure 15.

Figure 15: Mean Gradient (S3OUS VI Population)

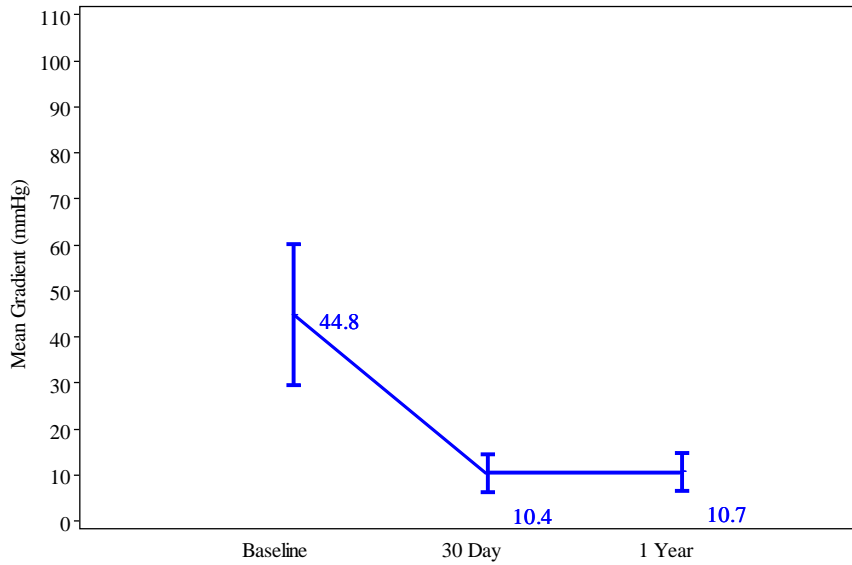

The mean peak gradient decreased from 77.5 ± 24.9 mmHg at baseline to 21.0 ± 7.7 mmHg at 30 days, and maintained at 21.5 ± 8.2 mmHg at 1 year, as shown in Figure 16.

Figure 16: Peak Gradient (S3OUS VI Population)

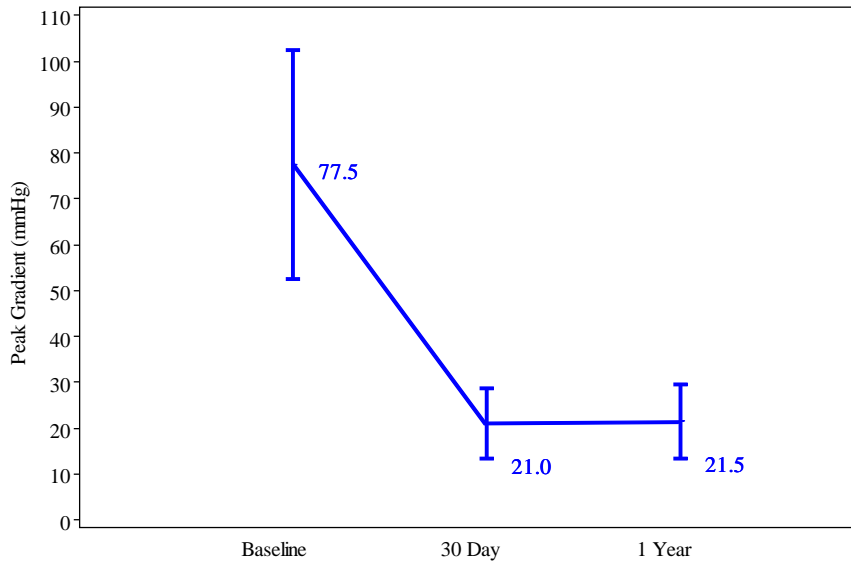

The proportion of patients with aortic insufficiency \geq moderate was 9.8% at baseline, 3.7% at 30 days, and 1.6% at 1 year, as shown in Figure 17.

Figure 17: Aortic Insufficiency (S3OUS VI Population)

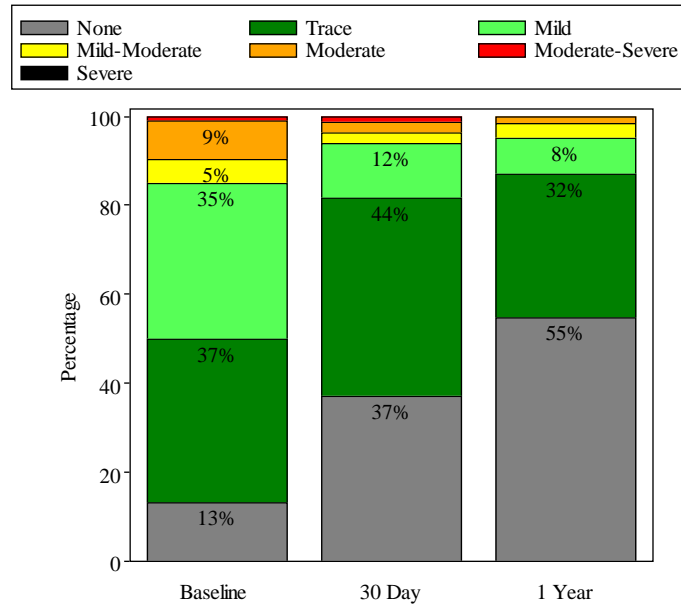

The proportion of patients with aortic PVL \geq moderate was 3.7% at 30 days, and 1.6% at 1 year, as shown in Figure 18.

Figure 18: Aortic Paravalvular Leak (S3OUS VI Population)

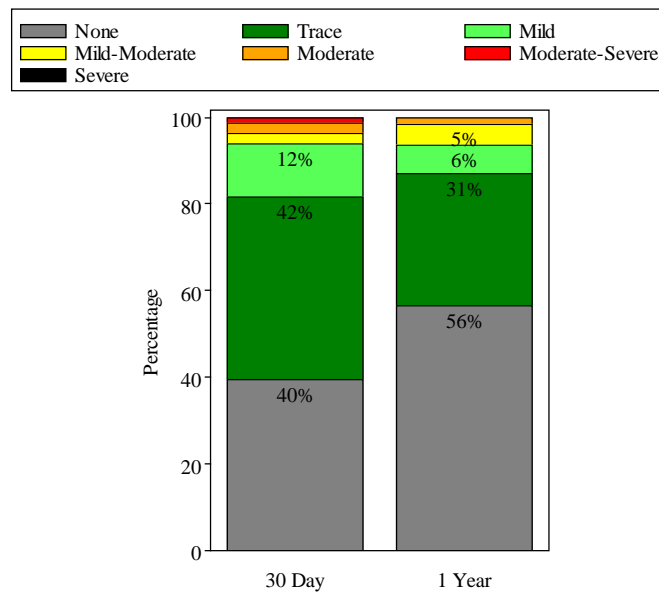

NYHA

The NYHA class by visit is shown in Figure 19. For all patients, the mean NYHA class decreased from 3.0 ± 0.5 at baseline to 1.6 ± 0.7 at 30 days and 1.8 ± 0.6 at 1 year.

Figure 19: NYHA Class by Visit (S3OUS AT Population)

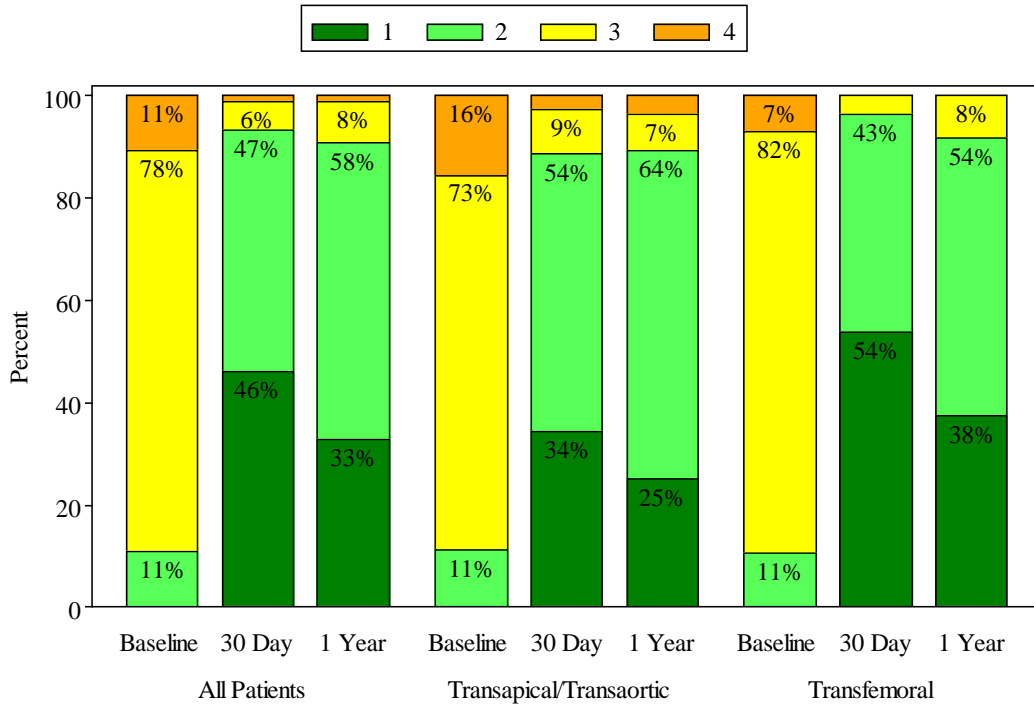

REFERENCES

- [1] Kappetein AP, Head SJ, Génereux P, et al. Updated standardized endpoint definitions for transcatheter aortic valve implantation: the Valve Academic Research Consortium-2 consensus document (VARC-2). *Eur J Cardiothorac Surg* 2012;42:S45-60.
- [2] Imbens G. W. (2004) Nonparametric Estimation of Average Treatment Effects under Exogeneity: A Review. *The Review of Economics and Statistics*, February 2004, 86(1): 4–29

These products are manufactured and sold under one or more of the following US patent(s): US Patent No. 5,411,552; 6,214,054; 6,547,827; 6,561,970; 6,908,481; 7,214,344; 7,510,575; 7,530,253; 7,585,321; 7,780,723; 7,846,203; 7,993,394; 8,057,540; 8,382,826; and 8,591,575 and corresponding foreign patents. Additional patents are pending.



XX/2015
©Copyright 2014, Edwards Lifesciences LLC
All rights reserved.

Manufacturer
Edwards Lifesciences LLC
One Edwards Way
Irvine, CA 92614-5688 USA
Made in USA

Telephone 949.250.2500
800.424.3278
FAX 949.250.2525

Web IFU
XXXXXXXXXX

