

REVO15|24

Laguna REVO 15|24 Woodturning Lathe Owner's Manual

Original Publication Date: 12/11209

SKU: MLAREVO1524110

PID: 415241

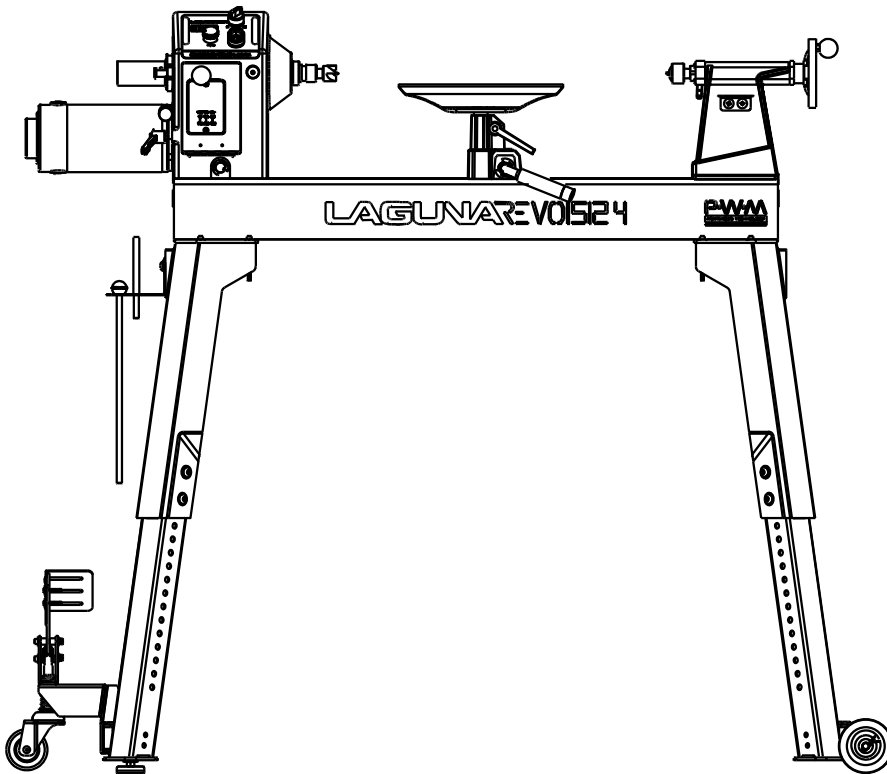

Laguna Tools® All rights reserved.
2072 Alton Parkway Irvine, CA 92606 U.S.A.
Service: +1 (949) 474-1200 or email customerservice@lagunatools.com
lagunatools.com



LAGUNA

Laguna takes pride in our products and stands behind them with continuing service and support for our customers. Your Laguna machine was designed to bring a new dimension of productivity to your shop.

Before using your machine for the first time, learn how to use it. This manual covers a step-by-step process of assembly and machine operation. If you have any questions, this manual will provide answers.

We do our best to thoroughly document every product that we sell for customer reference. Several files are compiled to cover all components of a machine.

- Several machines may be covered by one manual.
- Many machines sold by Laguna include components with independent owners' manuals.

Owner's Manuals

Owners' manuals will guide the purchasing party

- Warranty - All information about warranty, how to file a warranty claim, and how-to receiver support.
- Safety - The safety related rules and guidelines set forth by the manufacturing parties to be strictly followed in the operation of the machine or product.
- Set Up - Guidelines to set-up the product from state of shipping to state of operation.
- Operation - Procedure based sections covering the basic operations.
- Maintenance - Maintenance Schedule and procedures that must be followed.
- Troubleshooting - Procedure based help sections to repair faults.
- Parts - A list of replacement parts offered. This section may not include all the parts included with the purchase. If the part was not included in this section, then it will be available from a third party.
- Schematics – Drawings of electrical, pneumatic, and dimensional configurations of the machine or product.

Specification Sheets

Specification Sheets will aid in proper machine selection and serve as a reference for the purchasing party. For convenience, the specifications sheet has been included in the end of this manual.

- Several machines may be covered by one manual.
- Description - A detailed description of why the machine was developed,
- General Specifications - All specifications that are common to all machine categories.
- Category Specifications - Specifications unique to the specific category of the machine.
- Dimensional Drawing
- Capacities Drawing

Videos

In most cases a video is the best media to cover a setup or help topic.

All videos made by Laguna are uploaded and stored to youtube.com where they are then linked to websites.

<https://www.youtube.com/user/LagunaTools>

Websites

Our Website holds all information about any product. Check it often for any updates to your machine.

As innovation happens, that is where you will find it.

lagunatools.com
lagunatools.ca
lagunatools.eu
supermaxtools.com
lagunacleanair.com
lagunalathe.com

The information contained in this publication was correct at the time of print. In the interest of continuous innovation, we reserve the right to change specifications, design or included equipment without notice or obligation. No part of this publication may be reproduced, transmitted, or translated into any language in any form by any means without our written permission. Errors and omissions may be current.

Laguna Tools, Inc. LAGUNA® and the LAGUNA Logo® are the registered trademarks of Laguna Tools, Inc.

All rights reserved. 03/01/2020

Table of Contents

Table of Contents	2
Warranty & Support	3
Registration	3
Who Is Covered?.....	3
What Is Covered.....	3
Warranty Limitations.....	3
Length of Warranty	3
Shipping Damage.....	3
Safety.....	4
Safety Guidelines - Definitions	4
Important Safety Instructions.....	4
General Safety Rules	4
Manufacture Lathe Safety Rules	5
Specifications	9
Dimensions	11
General.....	11
OPTIONAL Expansion Set	12
OPTIONAL Mobility Kit.....	13
Set Up	14
Lathe Assembly.....	15
OPTIONAL Expansion Set	19
OPTIONAL Mobility Kit.....	20
Adjustments.....	26
Maintenance	27
Lathe will not start.	27
The machine will not stop.	27
Motor tries to start but will not turn.....	27
Squeaking noise.....	27
Spindle slows down during a cut.	27
Machine vibrates.....	27
Digital Read Out (DRO) is displaying an error.	27
Wiring	29
Parts.....	30
HeadStock.....	30
Tailstock, Banjo, Tool Rest.....	31
Bed & Leg Assembly	32
Parts Table	33
OPTIONAL Wheel System	36
OPTIONAL Expansion Set	38

Warranty & Support

This machine is covered by a warranty and your dealer can answer any questions you may have. Additionally, we will always be here to offer support, service information, and product supplies and services.

Laguna Tools® Customer Service
2072 Alton Parkway, Irvine,
California 92606, USA
8AM ET to 5PM PST Monday through Friday
LagunaTools.com

Service: +1 (949) 474-1200
customerservice@lagunatools.com

Every product sold is warranted to be free of manufacturers' defective workmanship, parts, and materials. For any questions about this product, the intended use or what it was designed for, customer service, or replacement parts – please reach out to our customer service department.

Registration

To prevent voiding this warranty, all products sold must be registered within thirty (30) days of receiving. Registering the product will enable the original purchaser to receive notifications about important product changes and receive customer support.

<https://lagunatools.com/policies/warranty/>

Who Is Covered?

The applicable warranty covers only the initial purchaser of the product from the receipt date. The original purchaser must present the original receipt as proof of purchase.

What Is Covered

Any part, determined by Laguna Tools®, to have a defect will be repaired or replaced (and shipped), without charge. It is required that the defective item/part be returned to Laguna Tools® with the complaint and proof of purchase in the original packaging that it was received. In the event the item/part is determined to be void of this warranty, the customer will be responsible for the cost to replace the item/part and all related shipping charges.

Warranty Limitations

This limited warranty does not apply to natural disasters, acts of terrorism, normal wear and tear, product failure due to lack of maintenance or cleaning, damage caused by accident, neglect, or lack-of/inadequate dust collection. The warranty may be voided against proof of misuse/abuse, damage caused

where repair or alterations have been made or attempted by others, using the product for purposes other than those described as intended use (unless with consent by Laguna Tools®), modification to the product, or use with an accessory that was not designed for the product. It is the responsibility of the user to understand basic woodworking machinery settings and procedures and to properly maintain the equipment in accordance with the standards provided in this manual.

Length of Warranty

2 Year – New purchases through authorized dealers.
1 Year – New purchases directly from Laguna Tools.
1 Year – Blades and Accessories

Aside from being free of defects upon receiving, consumable parts, like cutters and abrasives, are not covered by this warranty unless otherwise stated by Laguna Tools®. These parts are designed to be used at the expense of the operator and are available for replacement or inventory purchase.

Shipping Damage

Laguna Tools® and the purchasing customer is not responsible for damage or loss caused by a freight company or other circumstances not in the direct control of Laguna Tools®.

All shipping related claims for loss or damaged goods must be made to Laguna Tools within twenty-four hours of delivery.

Safety

Read and understand all warnings and operation instructions before using any tool or equipment. Always follow basic safety precautions to reduce the risk of personal injury. Improper operation, maintenance or modification of tools or equipment could result in serious injury and property damage. There are certain applications for which tools and equipment are designed. This product should NOT be modified and/or used for any application other than for which it was designed.

It is important for you to read and understand this manual. The information it contains relates to protecting your safety and preventing problems.

Safety Guidelines - Definitions

This manual contains information that is important for you to know and understand. This information relates to protecting your safety and preventing equipment problems. To help you recognize this information, we use the symbols below. Please read the manual and pay attention to these sections.

⚠ DANGER! or **DANGER!** Indicates an imminently hazardous situation which, if not avoided, will result in death or serious injury.

⚠ WARNING! or **WARNING!** Indicates a potentially hazardous situation which, if not avoided, could result in death or serious injury.

⚠ CAUTION! or **CAUTION!** Indicates a potentially hazardous situation which, if not avoided, may result in minor or moderate injury.

TECH TIP Indicates a helpful tip from our technical staff.

Important Safety Instructions

⚠ WARNING! Read and understand all warnings and operating instructions before using this equipment. Failure to follow all instructions listed below, may result in electric shock, fire, and/or serious personal injury or property damage.

Woodworking can be dangerous if safe and proper operating procedures are not followed. As with all machinery, there are certain hazards involved with the operation of the product. Using the machine with respect and caution will considerably lessen the possibility of personal injury. However, if normal safety precautions are overlooked or ignored, personal injury to the operator may result. Safety equipment such as guards, push sticks, hold-downs, feather boards, goggles, dust masks and hearing protection can reduce your potential for injury. But even the best guard won't make up for poor judgment, carelessness or inattention. Always use common sense and exercise caution in the workshop. If a procedure feels dangerous, don't try it. Figure out an alternative procedure that feels safer. **REMEMBER:** Your personal safety is your responsibility.

⚠ WARNING! This machine was designed for certain applications only. We strongly recommend that this machine not be modified and/or used for any application other than that for which it was designed. If you have any questions relative to a particular application, do not use the machine until you have first contacted the manufacturer to determine if it can or should be performed on the product.

If you have any questions relative to its application do not use the product until you have contacted the manufacturer and we have advised you.

General Safety Rules

⚠ WARNING! FAILURE TO FOLLOW THESE RULES MAY RESULT IN SERIOUS PERSONAL INJURY.

FOR YOUR OWN SAFETY, READ AND UNDERSTAND THE INSTRUCTION MANUAL BEFORE OPERATING THE MACHINE. Learn the unit's application and limitations as well as the specific hazards peculiar to it.

KEEP WORK AREA CLEAN. Cluttered areas and benches invite accidents.

DON'T USE IN DANGEROUS ENVIRONMENT. Don't use this unit in damp or wet locations or expose it to rain. Keep work area well-lighted.

KEEP CHILDREN AND VISITORS AWAY. All children and visitors should be kept a safe distance from work area.

DISCONNECT UNIT before servicing.

CHECK DAMAGED PARTS. Before further use of the unit, properly repair or replace any part that is damaged.

Manufacture Lathe Safety Rules

WARNING! For Your Own Safety Read Instruction Manual before Operating Lathe

- (a) Wear eye protection.
- (b) Do not wear gloves, a necktie, or loose clothing.
- (c) Tighten all locks before operating.
- (d) Rotate work piece by hand before applying power.
- (e) Rough out work piece before installing on faceplate.
- (f) Do not mount split work piece or one containing a knot.
- (g) Use lowest speed when starting new work piece.

SAFETY RULES

1. KEEP GUARDS IN PLACE and in working order.
2. REMOVE ADJUSTING KEYS AND WRENCHES. Form habit of checking to see that keys and adjusting wrenches are removed from tool before turning it on.
3. KEEP WORK AREA CLEAN. Cluttered areas and benches invite accidents.
4. DON'T USE IN A DANGEROUS ENVIRONMENT. Don't use power tools in damp or wet locations, or expose them to rain. Keep work area well lighted.
5. KEEP CHILDREN AWAY. All visitors should be kept at a safe distance from the work area.
6. MAKE YOUR WORKSHOP KID PROOF with padlocks, master switches, or by removing starter keys.
7. DON'T FORCE TOOL. It will do the job better and safer at the rate for which it was designed.
8. USE RIGHT TOOL. Don't force tool or attachment to do a job for which it was not designed.
9. USE PROPER EXTENSION CORD. Make sure your extension cord is in good condition. When using an extension cord, be sure to use one heavy enough to carry the current your product will draw. An undersized cord will cause a drop in line voltage resulting in loss of power and overheating. Table A shows the correct size to use depending on cord length and nameplate ampere rating. If in doubt, use the next heavier gauge. The smaller the gauge number, the heavier the chord.
10. WEAR PROPER APPAREL Do not wear loose clothing, gloves, neckties, rings, bracelets, or other jewelry which may get caught in moving parts. Nonslip footwear is recommended. Wear protective hair covering to contain long hair.
11. ALWAYS USE SAFETY GLASSES. Also use a face or dust mask if cutting operation is dusty. Everyday eyeglasses only have impact resistant lenses, they are NOT safety glasses.
12. SECURE WORK. Use clamps or a vise to hold the work when practical. It's safer than using your hand and it frees both hands to operate the tool.
13. DON'T OVERREACH. Keep proper footing and balance at all times.
14. MAINTAIN TOOLS WITH CARE. Keep tools sharp and clean for best and safest performance. Follow instructions for lubricating and changing accessories.
15. DISCONNECT TOOLS before servicing and when changing accessories, such as blades, bits, cutters, and the like.
16. REDUCE THE RISK OF UNINTENTIONAL STARTING. Make sure power switch is in the OFF position before plugging the machine in.
17. USE RECOMMENDED ACCESSORIES. Consult the owner's manual for recommended accessories. The use of improper accessories may cause risk of injury to persons.
18. NEVER STAND ON TOOL Serious injury could occur if the tool is tipped or if the cutting tool is unintentionally contacted.
19. CHECK DAMAGED PARTS. Before further use of the tool, a guard or other part that is damaged should be carefully checked to determine that it will operate properly and perform its intended function - check for alignment of moving parts, binding of moving parts, breakage of parts, mounting, and any other conditions that may affect its operation. A guard or other part that is damaged should be properly repaired or replaced.
20. DIRECTION OF FEED. Feed work into a blade or cutter against the direction of rotation of the blade or cutter only.
21. NEVER LEAVE TOOL RUNNING UNATTENDED. TURN POWER OFF. Don't leave tool until it comes to a complete stop.

AVERTISSEMENT! Pour votre sécurité, lire le manuel d'instru on a en vement avant d' liser le tour à bois.

- (a) Portez des lune es de protec
- (b) Ne pas porter de gants, de cravate, ou de vêtements amples.
- (c) Serrer tous les verrous avant d'opérer la machine.
- (d) Tourner la pièce à la main avant d'appliquer le courant.
- (e) Débiter grossièrement la pièce avant de l'installer sur le plateau de montage.
- (f) Ne pas monter une pièce fendue ou comportant un noeud.

(g) Utiliser la vitesse la plus lente au démarrage d'une nouvelle pièce.

RÈGLES DE L'OPÉRATEUR

1. CONSERVEZ TOUS LES DISPOSITIFS DE PROTECTION EN PLACE et en bon état de fonctionnement.
2. ENLEVEZ LES CLÉS ET OUTILS. Prenez l'habitude de vérifier si les clés et autres outils ne sont pas trop près de la machine avant de la démarrer.
3. CONSERVEZ LA SURFACE DE TRAVAIL PROPRE ET LIBRE D'ENTRAVES. Les endroits encombrés augmentent le risque d'accident.
4. NE PAS UTILISER DANS LES ENVIRONNEMENTS DANGEREUX. N'utilisez pas d'outils électriques dans les endroits humides, détrempés, ou sous la pluie. Conservez l'espace de travail bien éclairé.
5. TENEZ LES ENFANTS À L'ÉCART. Tous les visiteurs doivent être tenus à une distance sécuritaire de l'aire de travail.
6. RENDEZ L'ATELIER À L'ÉPREUVE DES ENFANTS avec des verrous, des interrupteurs principaux ou en enlevant les clés de démarrage sur les machines.
7. NE FORCEZ PAS L'OUTIL. L'outil effectuera un meilleur travail et de façon sécuritaire s'il est utilisé au rythme pour lequel il a été conçu.
8. UTILISEZ L'OUTIL APPROPRIÉ. Ne forcez pas un outil ou un accessoire pour effectuer un travail pour lequel il n'a pas été conçu.
9. UTILISEZ UNE RALLONGE ÉLECTRIQUE APPROPRIÉE. Assurez-vous que votre rallonge électrique est en bon état et que le calibre du filage soit adéquat pour transporter le courant que la machine a besoin. Une rallonge de trop faible calibre induira une perte d'intensité du voltage, ce qui provoquera une surchauffe et une perte de puissance. Le tableau A indique le bon calibre à utiliser en fonction de la longueur de la rallonge et de la demande en intensité du moteur. En cas de doute, utilisez la rallonge de calibre plus fort. Plus le numéro est petit, plus la rallonge est de fort calibre.
10. PORTEZ DES VÊTEMENTS APPROPRIÉS. Ne portez pas de vêtements amples, des gants, des colliers, des bracelets, ou tout autre bijou ou accessoire qui pourrait être entraîné par des pièces mobiles. Des souliers à semelle antidérapante sont également recommandés. Attachez les cheveux longs et portez un bonnet pour contenir la chevelure trop abondante.
11. PORTEZ DES LUNETTES DE PROTECTION. Portez également un masque contre la poussière si le travail exécuté dégage de la poussière. Veuillez prendre note que les lunettes de prescription ordinaire ne résistent pas aux impacts et qu'elles ne sont pas homologuées à des fins de sécurité.
12. IMMOBILISEZ VOTRE TRAVAIL. Utilisez des serres ou un étau pour immobiliser votre travail lorsque c'est possible. C'est plus sécuritaire que d'utiliser votre main, et ça permet de libérer vos deux mains pour opérer confortablement.
13. NE VOUS ÉTIREZ PAS AU-DESSUS DE LA MACHINE. Demeurez solidement en équilibre sur vos pieds en tout temps.
14. ENTRETENEZ LES OUTILS AVEC SOIN. Gardez les outils de coupe tranchants et propres pour en tirer les meilleures performances. Suivez les instructions du fabricant pour la lubrification et l'entretien des accessoires.
15. DÉBRANCHEZ LES OUTILS avant d'en effectuer l'entretien ou lors du changement d'accessoires tels que lames ou couteaux.
16. RÉDUISEZ LES RISQUES DE DÉMARRAGE NON INTENTIONNEL. Assurez-vous que l'interrupteur est en position fermée avant le branchement d'un outil.
17. UTILISEZ LES ACCESSOIRES RECOMMANDÉS. Consultez le manuel d'instruction pour connaître les accessoires recommandés. L'utilisation d'accessoires inappropriés pose des risques de blessures aux utilisateurs.
18. NE VOUS TENEZ JAMAIS DEBOUT SUR UNE MACHINE. Des blessures graves pourraient survenir si la machine bascule ou si les outils coupants sont touchés accidentellement.
19. VÉRIFIEZ LES PIÈCES ENDOMMAGÉES. Avant de poursuivre l'utilisation d'un outil, tout dispositif de protection ou toute pièce endommagée devra être inspecté pour déterminer si elle peut fonctionner correctement et selon l'utilisation qui en est prévue. Vérifiez l'alignement des pièces mobiles à savoir s'il y a un blocage, un bris, ou toute autre condition qui nuirait à son utilisation. Une pièce ou un protecteur endommagé doit être réparé ou remplacé.
20. SENS D'ALIMENTATION. Alimentez la pièce vers la lame ou le couteau dans le sens contraire de sa rotation seulement.
21. NE LAISSEZ JAMAIS UN OUTIL FONCTIONNER DANS SURVEILLANCE – ÉTEIGNEZ L'OUTIL. Ne laissez pas l'outil sans surveillance jusqu'à ce qu'il s'arrête complètement.

TABLE A						
Ampere Rating		Volts	Total length of cord in feet			
		120	25	50	100	150
		240	50	100	200	300
More Than	Not More Than		Minimum gage for cord			
0	6		18	16	16	14
6	10		18	16	14	12
10	12		16	16	14	12
12	16		14	12	Not Recommended	

GROUNDING INSTRUCTIONS

1. All grounded, cord-connected tools:

In the event of a malfunction or breakdown, grounding provides a path of least resistance for electric current to reduce the risk of electric shock. This tool is equipped with an electric cord having an equipment-grounding conductor and a grounding plug. The plug must be plugged into a matching outlet that is properly installed and grounded in accordance with all local codes and ordinances. Do not modify the plug provided - if it will not fit the outlet, have the proper outlet installed by a qualified electrician. Improper connection of the equipment-grounding conductor can result in a risk of electric shock. The conductor with insulation having an outer surface that is green with or without yellow stripes is the equipment-grounding conductor. If repair or replacement of the electric cord or plug is necessary, do not connect the equipment-grounding conductor to a live terminal. Check with a qualified electrician or service personnel if the grounding instructions are not completely understood, or if in doubt as to whether the tool is properly grounded. Use only 3-wire extension cords that have 3-prong grounding plugs and 3 pole receptacles that accept the tool's plug. Repair or replace damaged or worn cord immediately.

2. Grounded, cord-connected tools intended for use on a supply circuit having a nominal rating less than 150 volts:

This tool is intended for use on a circuit that has an outlet that looks like the one illustrated in Sketch A in Fig. 1. The tool has a grounding plug that looks like the plug illustrated in Sketch A in Fig. 1. A temporary adapter, which looks like the adapter illustrated in Sketch B and C, may be used to connect this plug to a 2 pole receptacle as shown in Sketch B if a

properly grounded outlet is not available. The temporary adapter should be used only until a properly grounded outlet can be installed by a qualified electrician. This adapter is not permitted in Canada. The green-colored rigid ear, lug, and the like, extending from the adapter must be connected to a permanent ground such as a properly grounded outlet box.

3. Grounded, cord-connected tools intended for use on a supply circuit having a nominal rating between 150 – 250 volts, inclusive:

This tool is intended for use on a circuit that has an outlet that looks like the one illustrated in Sketch D. The tool has a grounding plug that looks like the plug illustrated in Sketch D. Make sure the tool is connected to an outlet having the same configuration as the plug. No adapter is available or should be used with this tool. If the tool must be reconnected for use on a different type of electric circuit, the reconnection should be made by qualified service personnel; and after reconnection, the tool should comply with all local codes and ordinances.

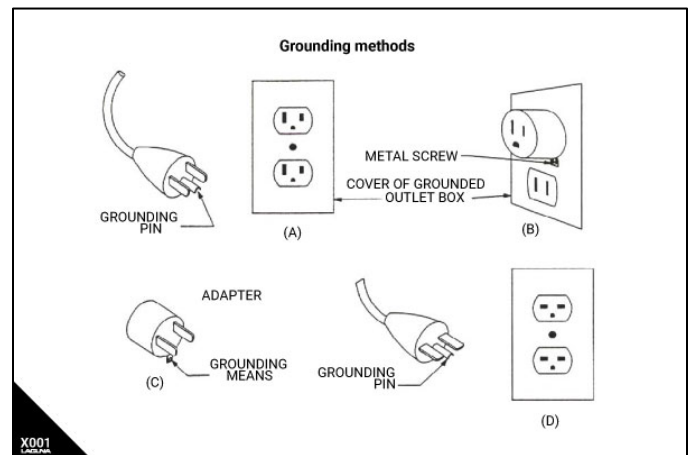

Fig X001: Grounding Methods Provided by CSA Group. (A) Receptacle with nominal rating less than 150 volts. (B) 150 volt receptacle without grounding pin fitted with adapter. (C) Grounding receptacle adapter. (D) Receptacle with nominal rating between 150 - 250 volts.

LOCKING THE LATHE

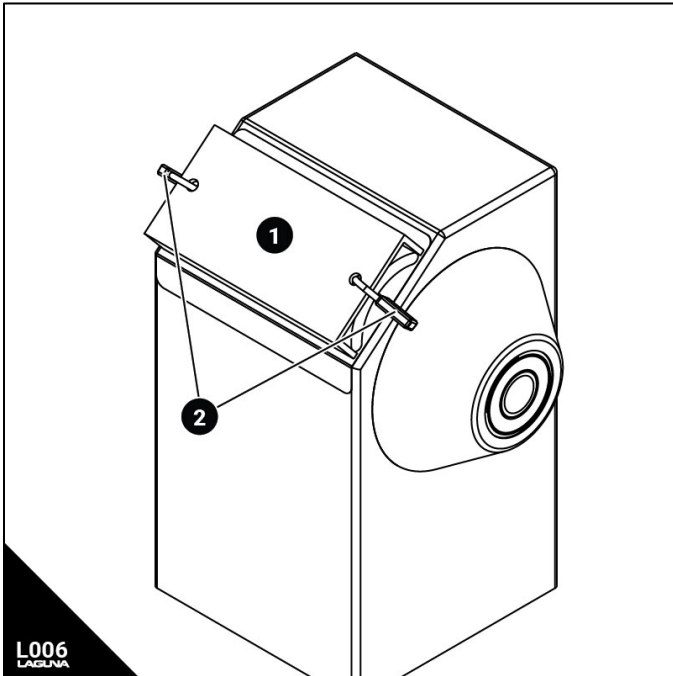

Fig L006 - Method of locking the Laguna Revo Lathe. (1) Constructed 3 side box with padlock holes. (2) Padlocks.

It is strongly recommended that the lathe is never left unattended in the unlocked condition. To lock the machine it is recommended that a cover (not supplied) is constructed according to the supplied concept displayed in Fig L006.

Noise Emission

Given that there exists a relationship between noise level and exposure times, it is not precise enough to

determine the need for supplementary precautions. The factors affecting the true level of exposure to operators are clearly the amount of time exposed, the characteristics of working environment other sources of dust and noise etc. For example, adjacent machines in other words the level of ambient noise. It is possible that exposure level limits will vary from country to country.

PROPOSITION 65 WARNING OF HARMFUL EXPOSURE

Some dust created by power sanding, sawing, grinding, drilling and other construction activities contains chemicals known to cause cancer, birth defects or other reproductive harm. Some examples of these chemicals are:

- Lead from lead-based paint.
- Crystalline silica from bricks, cement, and other masonry products.
- Arsenic and chromium from chemically treated lumber.

Your risk of exposure varies, depending on how often you do this type of work. To reduce your exposure to these chemicals, work in a well-ventilated area and work with approved safety equipment, such as face or dust masks that are specifically designed to filter out microscopic particles.

Save these instructions.

Refer to them often and use them to instruct others

Specifications

Specifications

LAGUNA REVO 15I24 WOODTURNING LATHE

SKUMLAREVO1524110
MPN.....415241
PID:.....415241
Package Dimensions (W x L x H) L51.6" W22" H21.9"

PRODUCT ASSEMBLED DIMENSIONS

High (W x L x H)..... L52.4" W19.9" H55.9"
Low (W x L x H) L48.6" W16.1" H42.2"
Gross Weight..... 302 LBS (137 KG)
Product Net Weight..... 288 LBS (130.6 KG)
Product Category Turning Machines
Product Subcategory Woodworking Lathe Machines
Certifications CSA C/US 256540
Dimensions
Overall Size (Highest) L52.4" W19.9" H55.9" (1330.7 mm, 506.4 mm, 1419.6 mm)
Overall Size (Lowest) L48.6" W16.1" H42.2" (1234.1 mm, 409.4 mm, 1070.7 mm)
Floor to bed height (Highest) 43.3" (1099.8 mm)
Floor to bed height (Lowest) 29.6" (750.9 mm)
Floor to Spindle Center (Highest) 51.4" (1296.7 mm)
Floor to Spindle Center (Lowest) 36.4" (924.6 mm)
Bed Length 44.1" (1120 mm)
Tool Rest Length 12" (304.8 mm)
Tool Rest Post Dia 1" (25.4 mm)
Faceplate Dia 3" (76.2 mm)

LATHE SPECIFICATIONS

Motor 1-1/2 HP, 8A
Power Requirements..... 110V, 1Ph, 60Hz
Speed Range High 650 - 4200 RPM
Speed Range Middle 325 - 2100 RPM
Speed Range Low 50 - 650 RPM
Distance Between Centers..... 24" (609.6 mm)
Swing Over Bed..... 15-1/2" (393.7 mm)
Swing Over Banjo..... 11-3/32" (281.7 mm)
Spindle Bore 3/8" (9.5 mm)
Spindle Taper..... MT2
Spindle Thread 1-1/4"x 8 TPI
Front Bearing 6206 LLU
Rear Bearing 6205 LLU
Indexing 24 positions w/ Lock
Inverter..... PWM inverter
Drive belt 6 Groove Poly-V Belt
Tail stock quill travel..... 4-1/2" (114.5 mm)
Tail stock taper MT2

Specifications

MATERIALS

Bed	Steel
Head/ Tail Stock	Cast Iron
Legs.....	Cast Iron Combined with Steel Tube
Tool Rest.....	1045 Steel
Tool Rest Contact Rod.....	6mm (DIA) Hardened 1045 Steel
Banjo	Cast Iron

FEATURES

Spring Loaded Spindle Lock	Standard
Outboard Turning.....	Optional
Wheel System.....	Optional
Self-Ejecting Tail Stock Removal	Standard
Tool Storage.....	Standard
Centers Storage on Tail Stock	Standard
Live Center	Standard
Drive Center	Standard
Faceplate	Standard
Forward/ Reverse Rotation.....	Standard
Digital Display for Speeds	Standard
110V Outlet for Work Light	Standard
Main Power ON/OFF Switch on Inverter Box.....	Standard
Operator Height Adjustment (Floor to Spindle Center 36.4" to 51.4").....	Standard
Center to Center Alignment Built on Tail Stock (US Patent Pending)	Standard

Dimensions

General

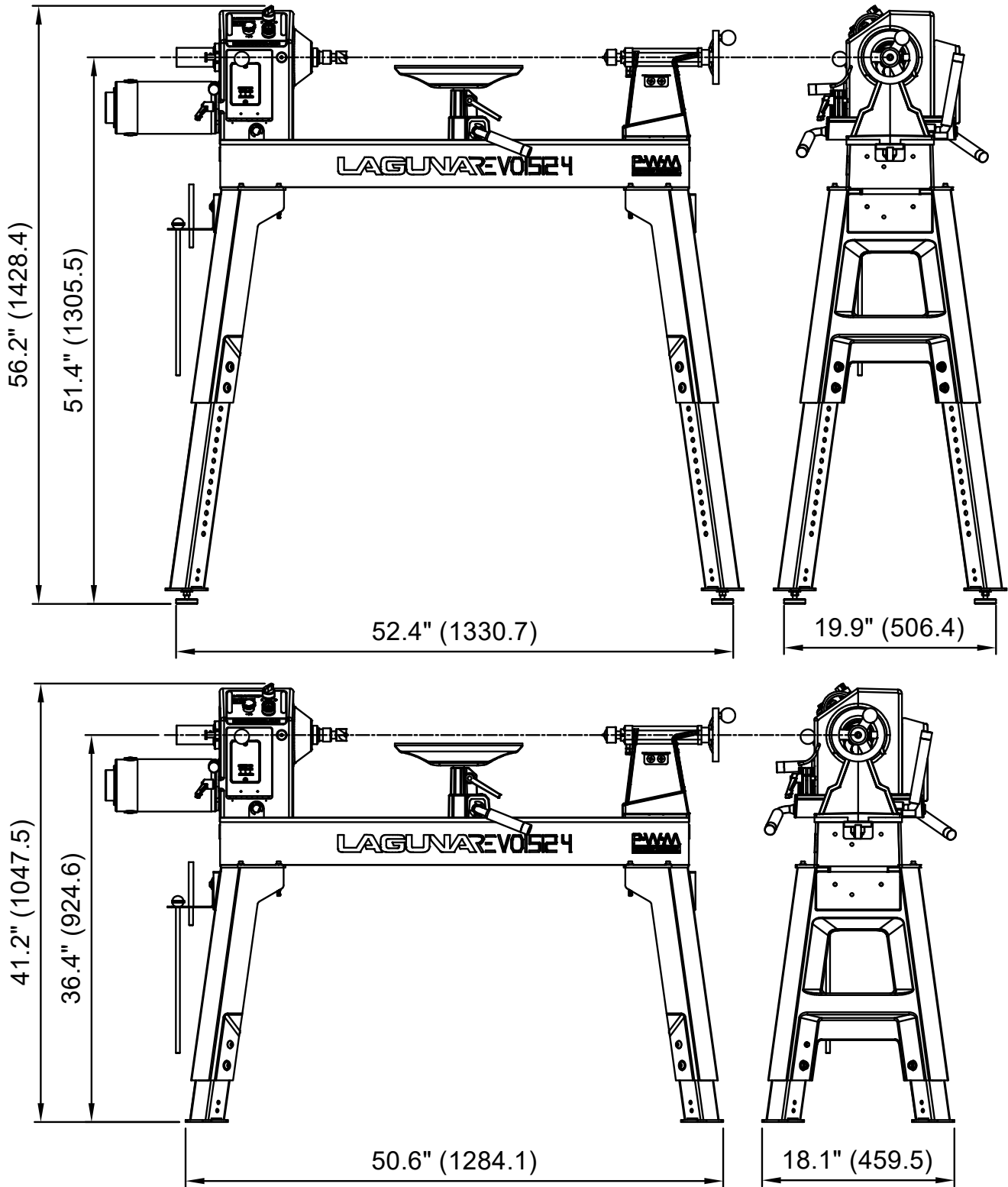

Dimensions

OPTIONAL Expansion Set

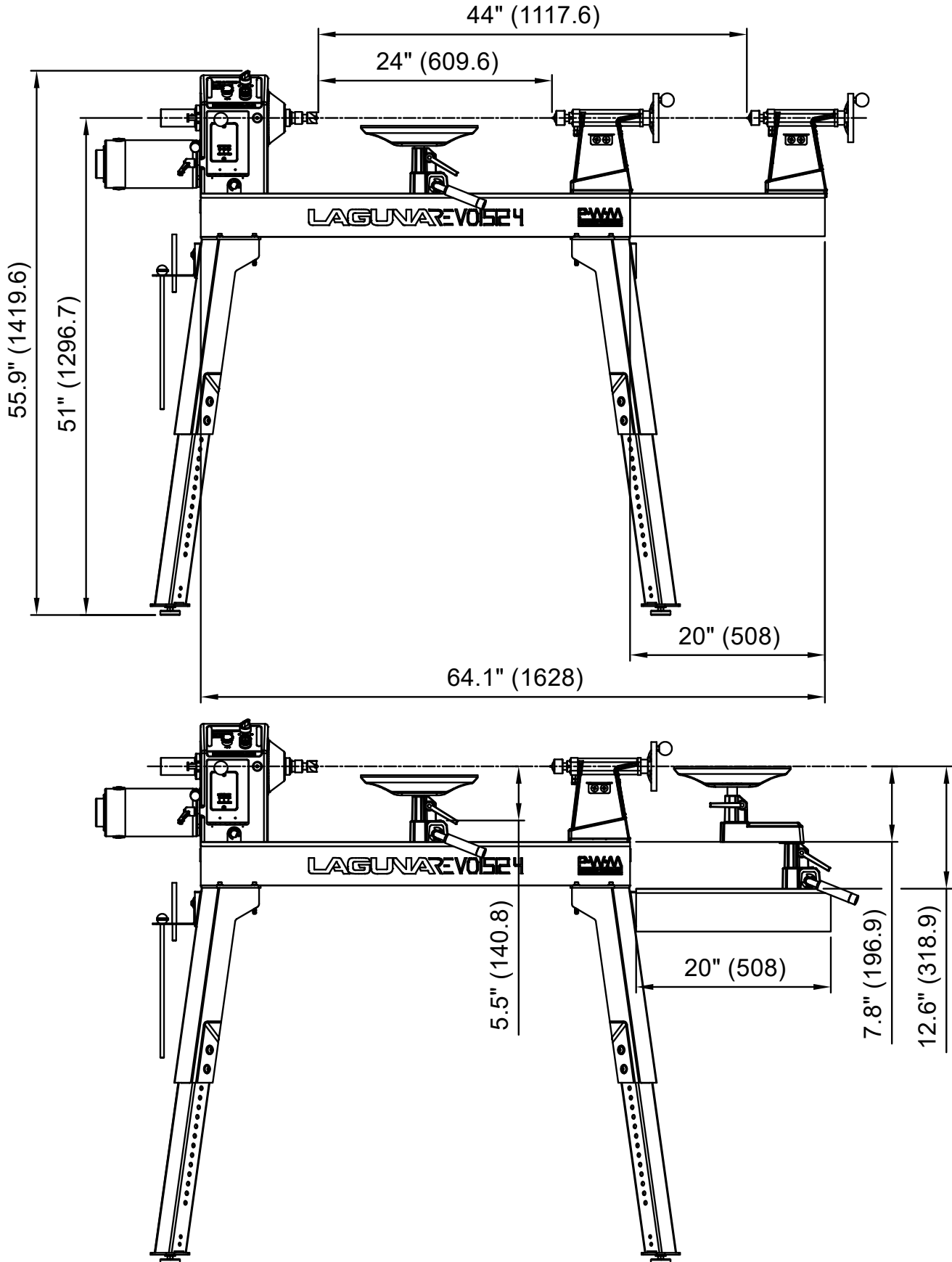

OPTIONAL Mobility Kit

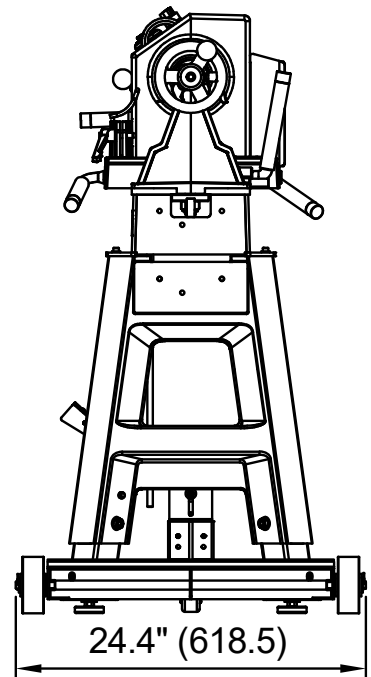
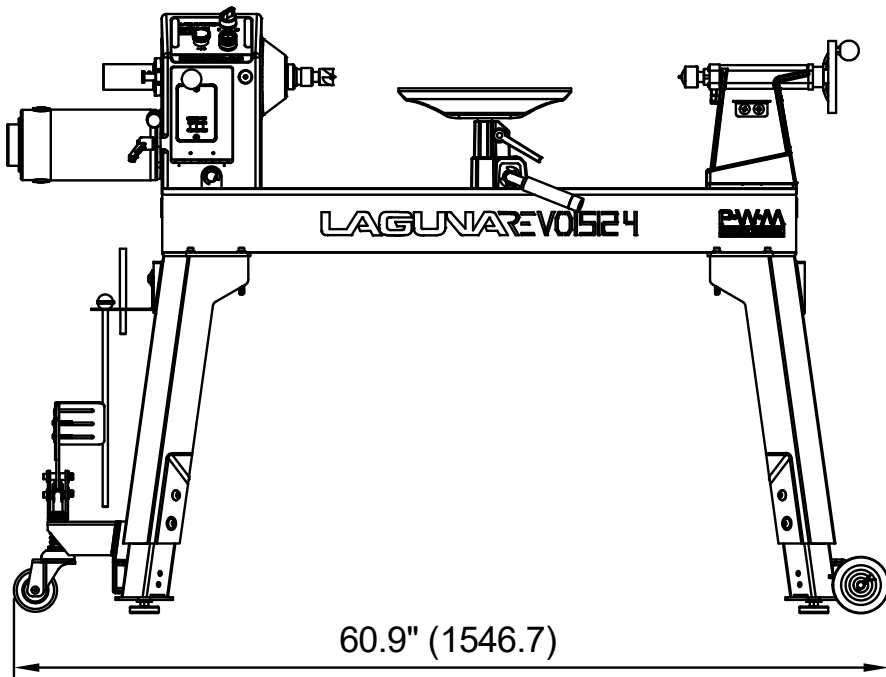
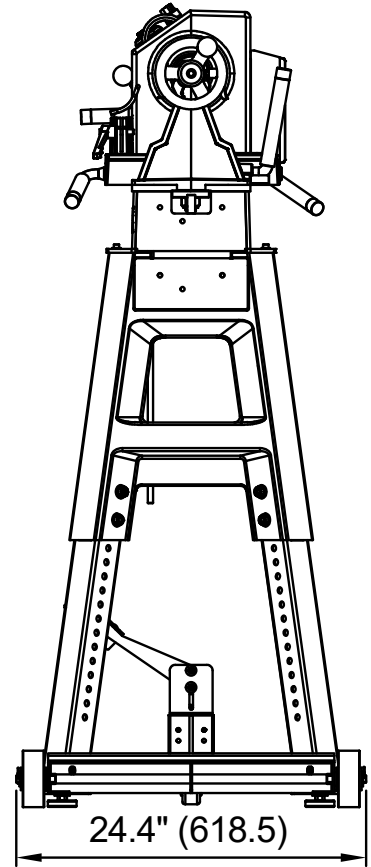
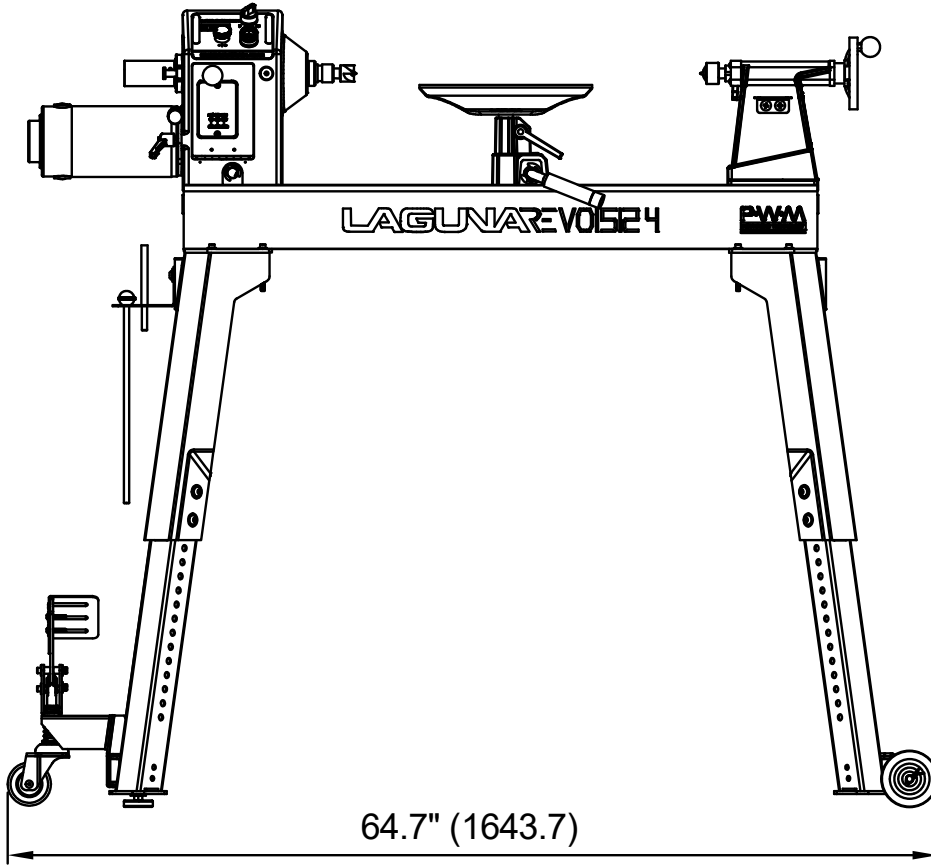

Set Up

Receiving

It is likely that your machine will be delivered by a third party. Before unboxing, be sure to inspect the packaging and shipping documents supplied by the driver. Ensure that there is no visible damage to the shipment. If any damage has occurred because of shipment, note the damage on the bill of lading or refuse the shipment. Immediately call the dealer store where the machine was purchased.

1. Never accept a shipment that is damaged or partial without notifying the shipping company and the purchasing store.

Placement

Prior to removing the machine from the packaging, decide the operating location of the machine. The dimensions and floor space can be found here: [Dimensions](#).

1. There should be sufficient area at the front of the machine to allow you to work on it comfortably.
2. There should be sufficient area at the back of the machine to allow access for adjustments and maintenance to be conducted.
3. The better the lighting the more accurately and safely you will be able to work.
4. You should select a solid flat floor, preferably one made of concrete or something similar.
5. Locate it close to a power source and dust collection (if applicable).

Unboxing

Once in place, carefully unbox and remove all components. Unboxing guidelines:

1. Do not cut deep into a box with a blade as it could scratch the paint; only cut deep enough to cut the tape or use a dull edge.
2. Prior to setting up the machine, organize all hardware and setup tools needed.

Set Up

Lathe Assembly

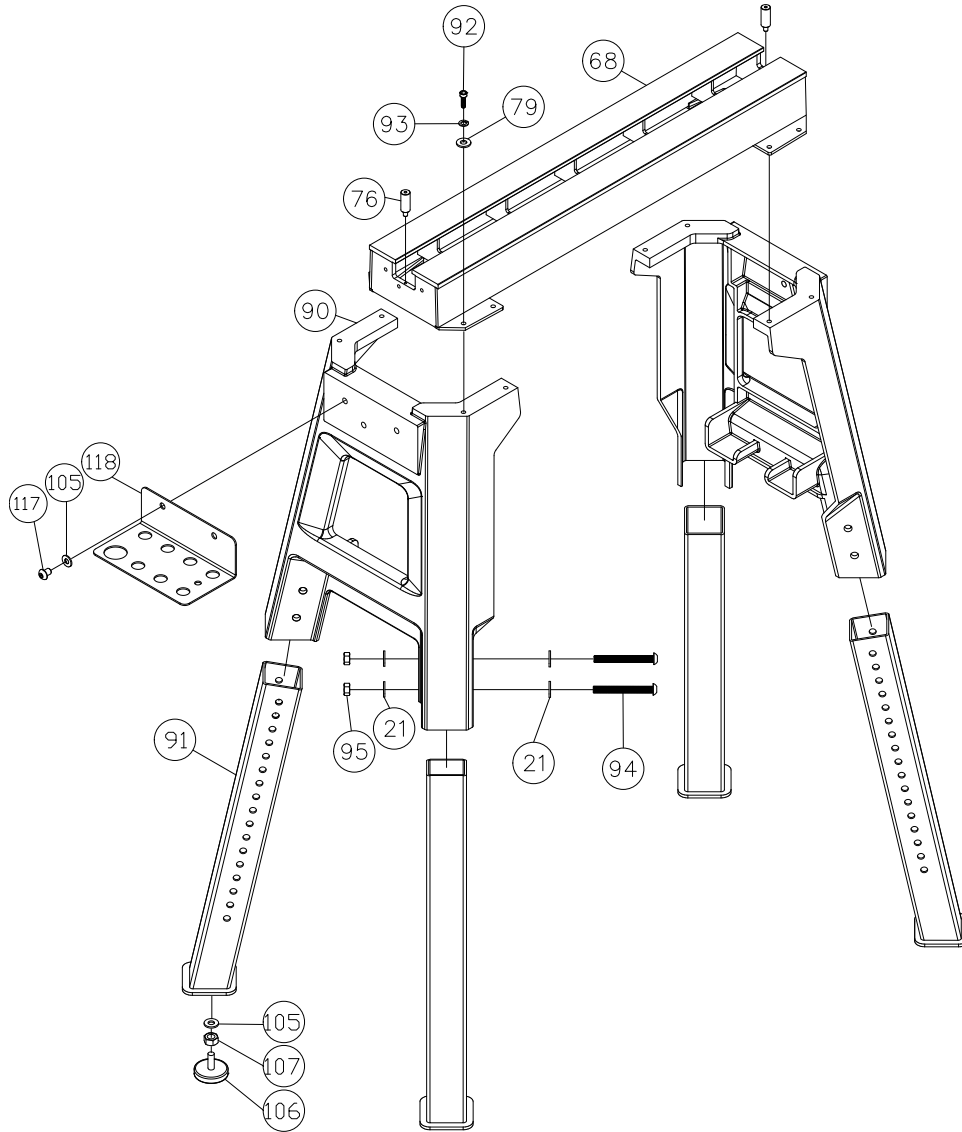

INDEX.....	PART NUMBER.....	DESCRIPTION.....	SPECIFICATION.....	QTY
21.....	415241-121.....	Flat Washer.....	D10xD23x2t.....	16
68.....	415241-168.....	Bed.....		1
76.....	PLAREVO1216-174.....	Stop Bolt.....		3
77.....	415241-177.....	Tailstock Locking Handle.....		1
79.....	415241-179.....	Flat Washer.....	D8xD18x2t.....	8
90.....	415241-190.....	Leg (Stand Body).....		2
91.....	415241-191.....	Tube, Leg.....		4
92.....	PLAREVO1836-197.....	Socket Head Cap Screw.....	5/16-18UNCx1".....	8
93.....	415241-193.....	Lock Washer.....	5/16".....	8
94.....	415241-194.....	Socket Head Button Screw.....	M10x90.....	8
95.....	415241-195.....	Nut.....	M10.....	8
105.....	PLAREVO1836-1112.....	Flat Washer.....	D10xD23x2t.....	8
106.....	415241-1106.....	Leveling Foot.....		4
107.....	PLAREVO1836-1111.....	Hex Nut.....	3/8-16UNC.....	4
117.....	PLAREVO1836-1126.....	Socket Head Button Screw.....	3/8-16UNCx5/8".....	2
118.....	PLAREVO1836-150.....	Tool Caddy.....		1

Step 1 – Install the Leveling Feet

Set Up

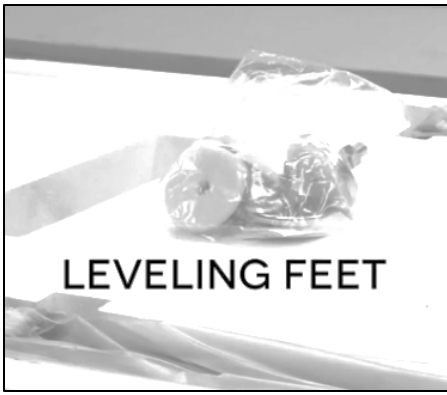

Locate the leveling feet from the carton. Install on all four legs to a finger tight position. You will further adjust the legs later to level the bed.

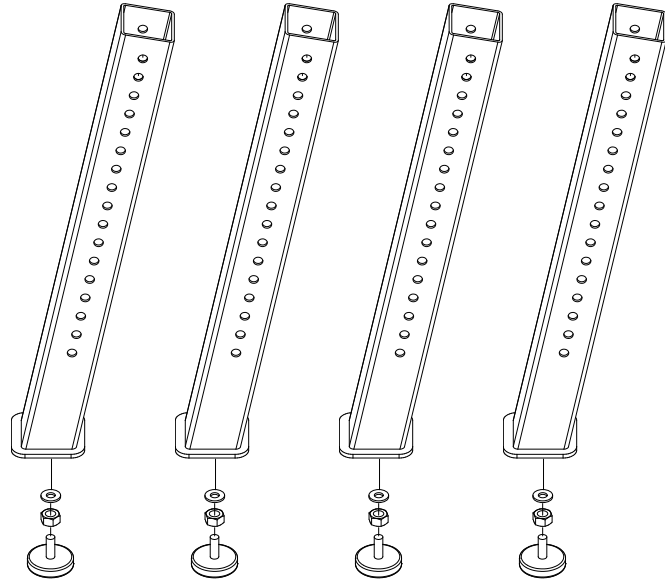

Step 2 – Fasten Legs to Stand Body

Locate the hardware, select an adequate height for lathe operation, bolt the four legs to stand bodies

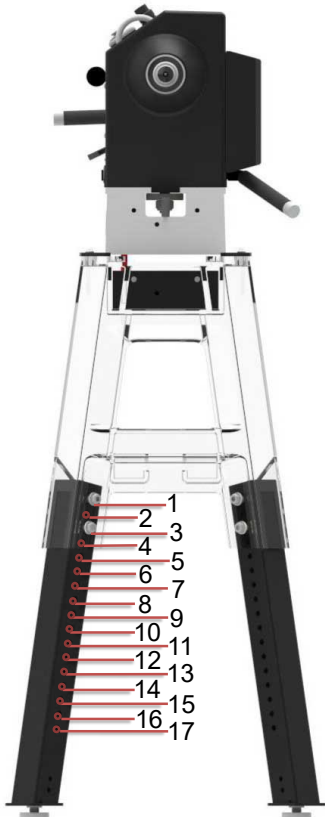

	Floor to Spindle Center
1,3	51"
2,4	50"
3,5	49"
4,6	48"
5,7	47"
6,8	46"
7,9	45"
8,10	44"
9,11	43"
10,12	42"
11,13	41"
12,14	40"
13,15	39"
14,16	38"
15,17	37"

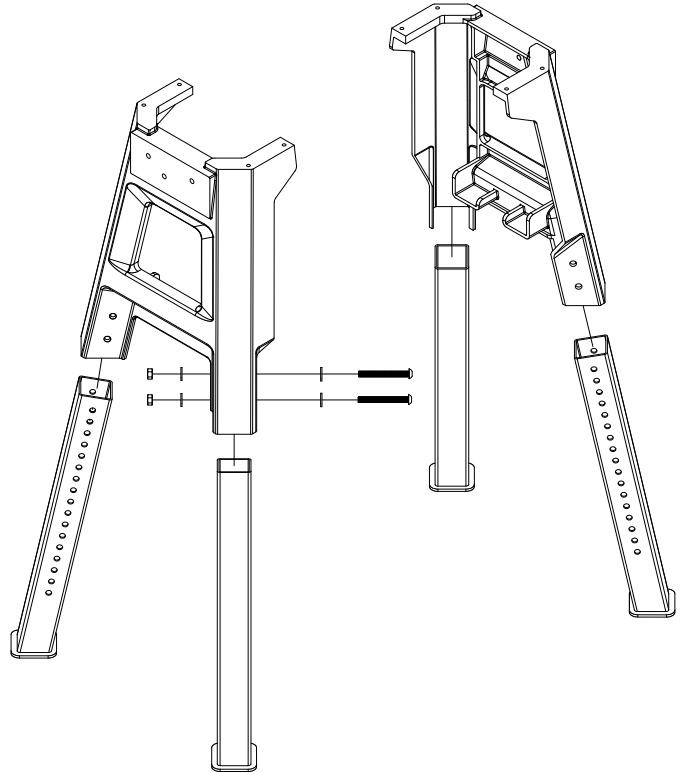

Set Up

Step 3 – Attach the Tool Shelf



Locate the Tool Shelf from the carton and bolt it onto the stand body.

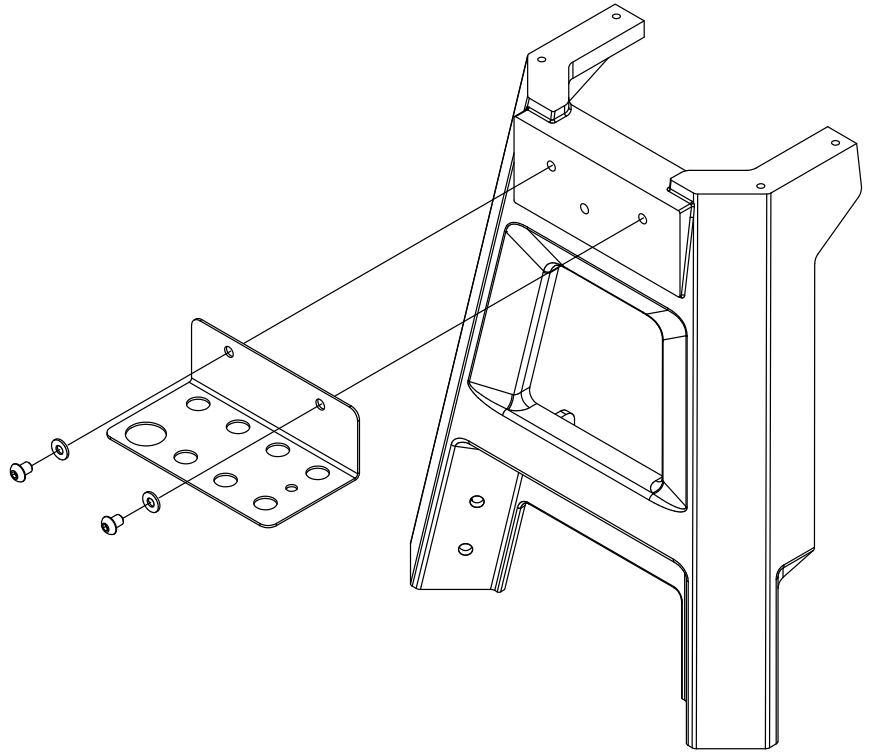

Step 4 – Bolt the bed to the assembled legs

The lathe will have the safety stops on each end of the bed upon shipment. Please remove the safety stop, headstock, banjo, and tailstock from the bed prior to bolting the bed to the stand.

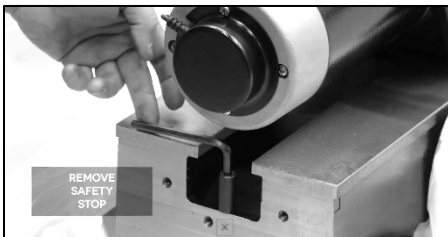

Remove Safety Stops



Release Pressure on Head Stock.

Set Up



Remove Head Stock



Remove Banjo



Remove Tail Stock

Locate the nuts and bolts and bolt down the bed to the legs

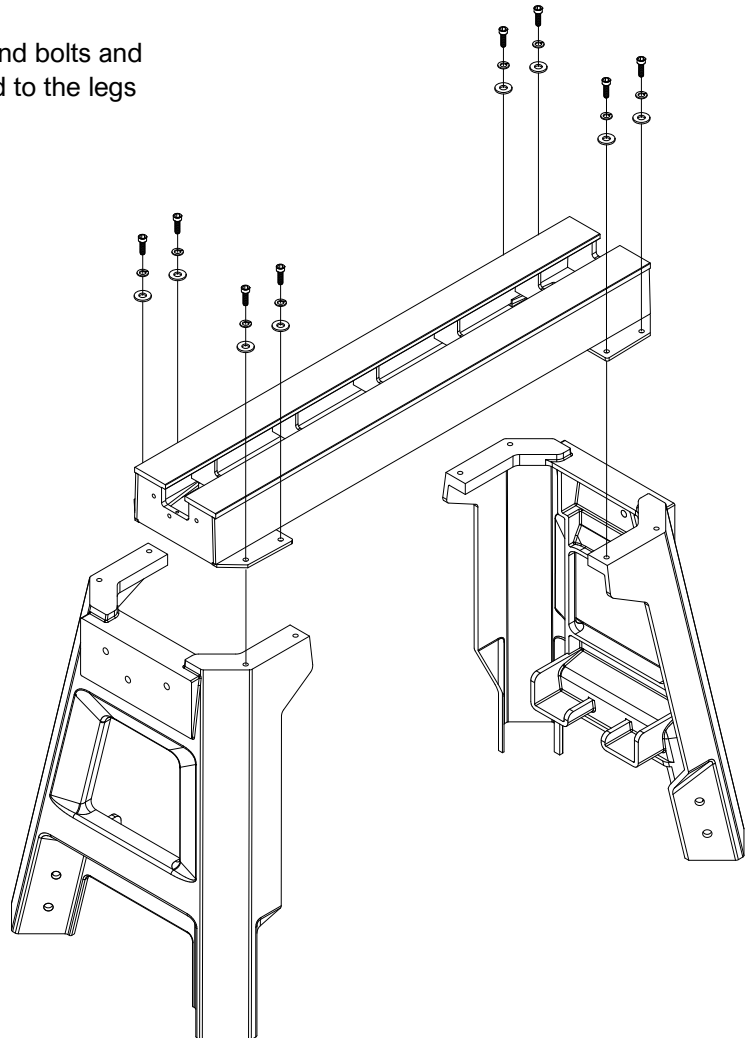

TECH TIP It is probably easiest to put the bed on the floor (protected with cardboard) and then install each leg. Once installed, careful flip the lathe up-wright.

OPTIONAL Expansion Set

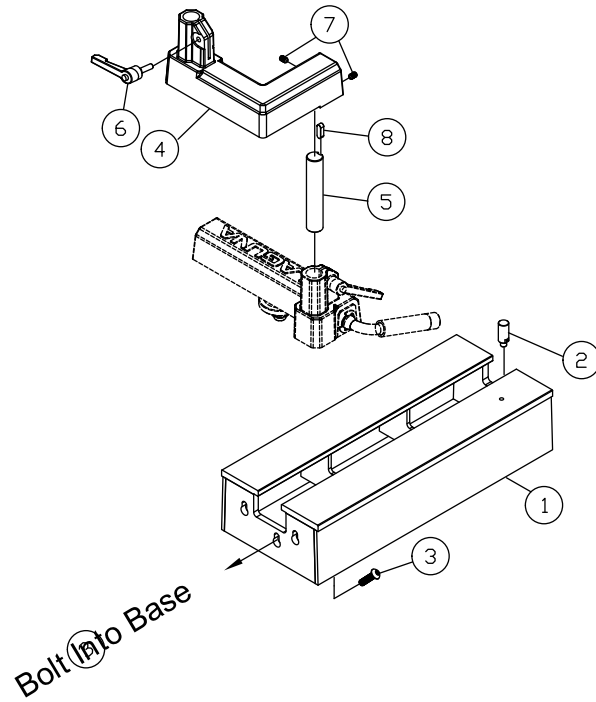

INDEX.....	PART NUMBER	DESCRIPTION	SPECIFICATION	QTY
1.....	PLAREVO1836-301	20" Bed Extension		1
2.....	PLAREVO1216-174	Stop Bolt		1
3.....	PLAREVO1836-303	Socket Head Button Screw	3/8-16UNCx1".....	3
4.....	415241-304.....	Tool Rest Support Base, Extension.....		1
5.....	415241-305.....	Shaft		1
6.....	PLAREVO1836-153.....	Lock Handle.....		1
7.....	415241-307.....	Set Screw	5/16-18UNCx1/2"	2
8.....	PLAREVO1836-186.....	Key.....	8x7x25	1

Set Up

OPTIONAL Mobility Kit

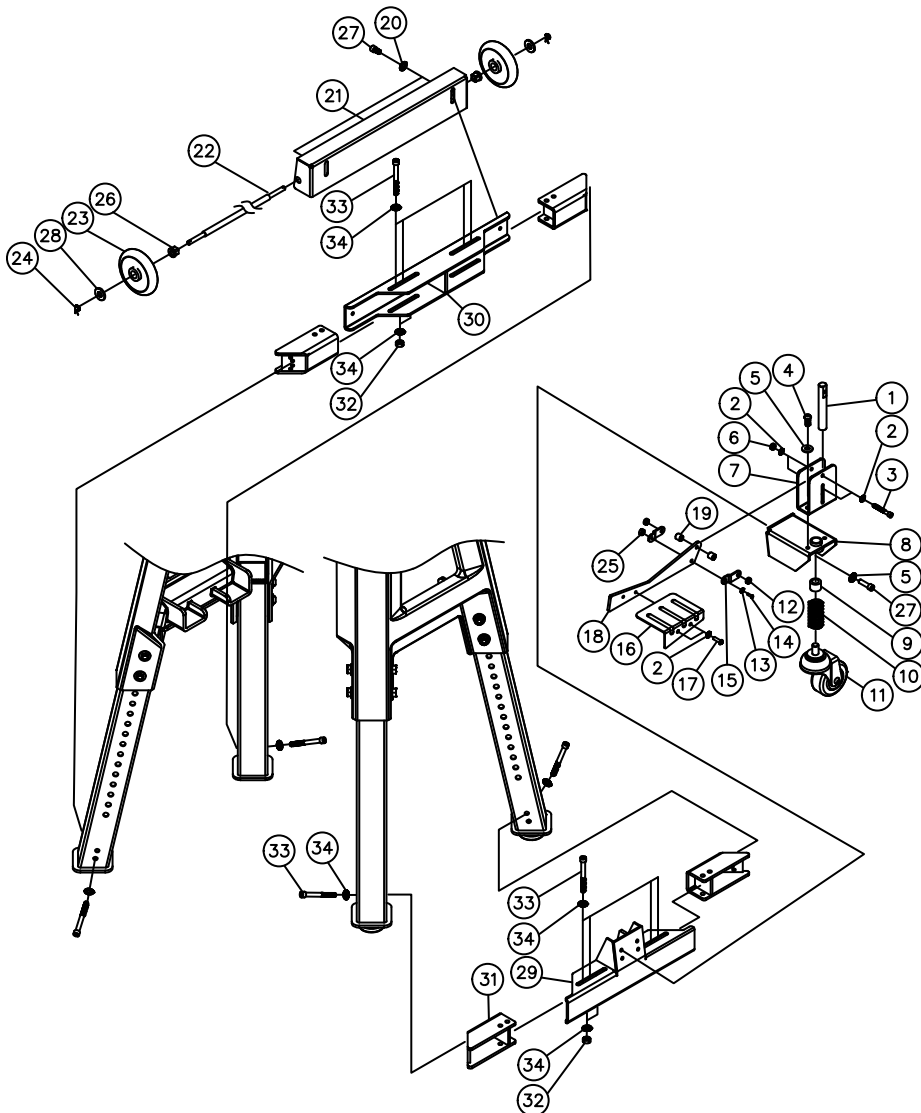
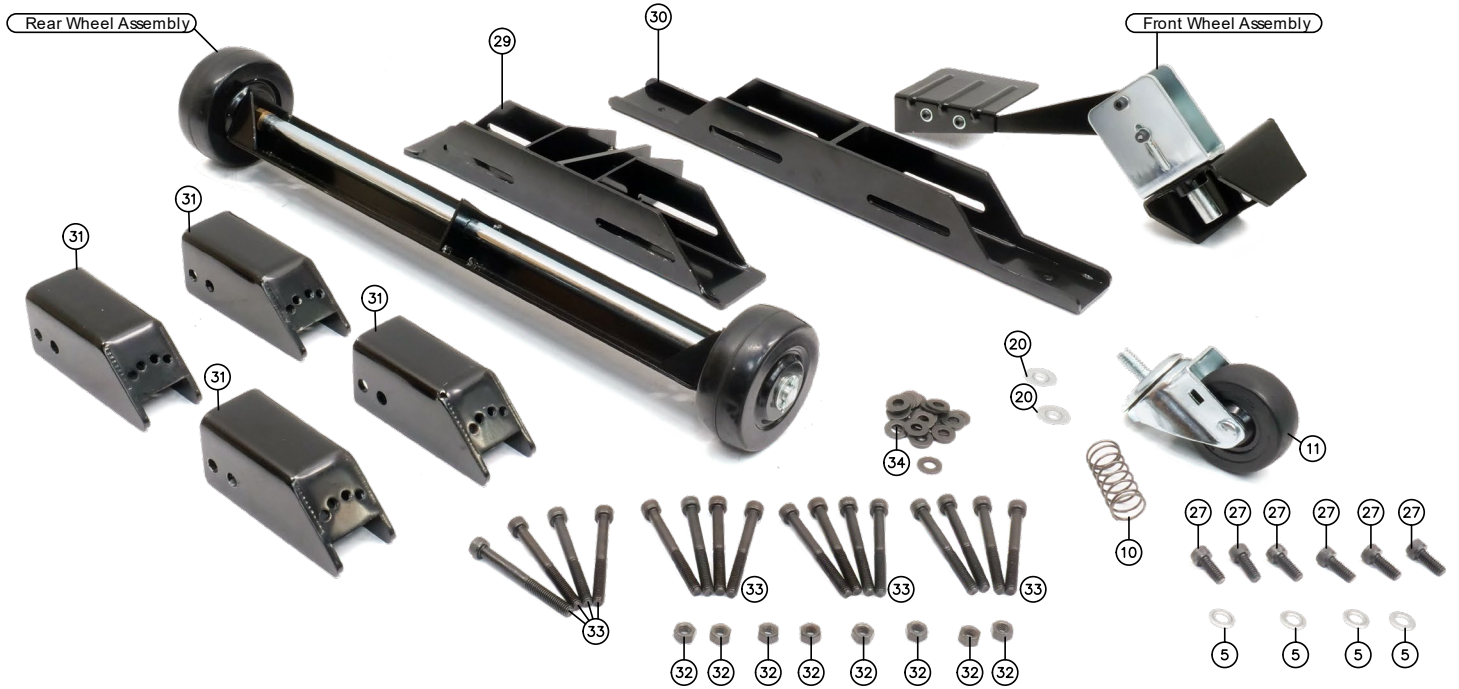

Set Up

INDEX.....	PART NUMBER.....	DESCRIPTION	SPECIFICATION	QTY
1.....	PBAND1412-175-6-1.....	Rod		1
2.....	PBAND1412-175-6-2.....	Flat Washer.....	1/4".....	6
3.....	PBAND1412-175-6-3.....	Socket Head Cap Screw	1/4"-20UNCx1-3/4".....	2
4.....	PBAND1412-175-6-4.....	Socket Head Button Screw	5/16"-18UNCx1/2".....	2
5.....	PBAND1412-175-6-5.....	Flat Washer.....	5/16".....	6
6.....	PBAND1412-175-6-6.....	Nylon Inserted Lock Nut.....	1/4"-20UNC.....	2
7.....	PBAND1412-175-6-7.....	Fixed Plate		1
8.....	PBAND1412-175-6-8.....	Wheel Bracket.....		1
9.....	PBAND1412-175-6-9.....	DU Bearing	MB1620DU.....	1
10.....	PBAND1412-175-6-10.....	Spring.....		1
11.....	PBAND1412-175-6-11.....	Caster.....		1
12.....	PBAND1412-175-6-12.....	Spacer.....		2
13.....	PBAND1412-175-6-13.....	Flat Washer.....	M5.....	1
14.....	PBAND1412-175-6-14.....	Screw	M5x0.8x20.....	1
15.....	PBAND1412-175-6-15.....	Connecting Plate		2
16.....	PBAND1412-175-6-16.....	Foot Pedal.....		1
17.....	PBAND1412-175-6-17.....	Socket Head Button Screw	1/4"-20UNCx3/8".....	2
18.....	PBAND1412-175-6-18.....	Plate.....		1
19.....	PBAND1412-175-6-19.....	Spacer.....		2
20.....	415241-220.....	Flat Washer.....	5/16".....	2
21.....	PBAND18BX2203-6-21.....	Support Plate.....		1
22.....	PBAND18BX2203-6-22.....	Rod		1
23.....	PBAND18BX2203-6-23.....	Wheel		2
24.....	PBAND18BX2203-6-24.....	Cotter pin.....	2x25mm.....	2
25.....	PBAND1412-175-6-25.....	Nylon Inserted Lock Nut.....	M5x0.8.....	1
26.....	PBAND18BX2203-6-26.....	Bushing		2
27.....	415241-227.....	Socket Head Cap Screw	5/16"-18UNCx3/4".....	6
28.....	PBAND18BX2203-6-28.....	Flat Washer.....	1/2".....	2
29.....	415241-229.....	Wheel Bracket.....		1
30.....	415241-230.....	Wheel Bracket.....		1
31.....	415241-231.....	Slide Bracket.....		4
32.....	415241-232.....	Hex Nut	5/16"-18UNC.....	8
33.....	415241-233.....	Socket Head Cap Screw	5/16-18UNCx3".....	16
34.....	415241-179.....	Flat Washer.....	M8.....	24

Set Up

Step 1 - Install the Slide Brackets



Place two bolts (index 33, 5/16-18UNCx3") in each leg, with one washer (index 34) for each bolt.



Install the four (index 34) slide brackets to the four wheels.

Thread the bolts directly into the slide brackets.

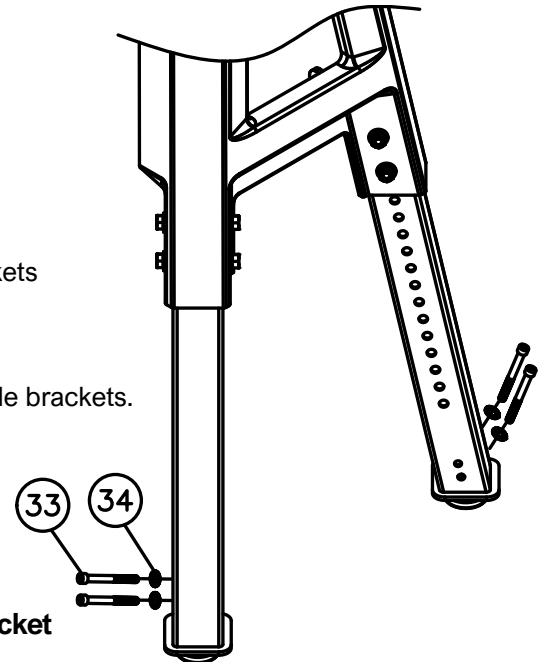

Step 2 - Install the rear wheel bracket

Install the rear wheel bracket (index 30) the left or right of the lathe using four bolts (index 33, 5/16-18UNCx3"), with two washers (index 38) and one nut (index 32) for each bolt.

TECH TIP It is up to user discretion to what side the front and rear wheel assemblies go on. Do what is best for your shop.



Place the bracket (30) on the two slide mounts.



Drop in the four bolts with one washer before each bolt, and then another washer before the nut, like this:



Tighten all hardware.

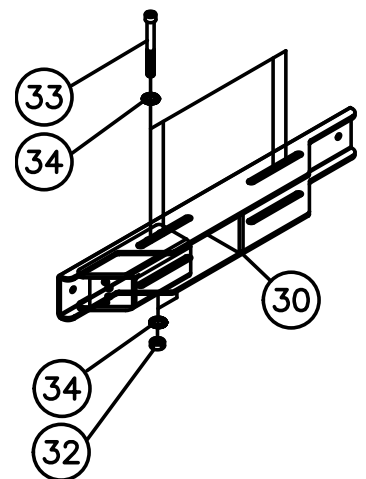

Set Up

Step 3 – Remove the leveling feet (only on the rear wheel side)



Place a support underneath the lathe to prop up and access the leveling feet for removal.



Remove both leveling feet.



Move the support such that there is access to the rear wheel bracket.

Step 4 – Install Rear Wheels



Mount the rear wheel assembly using two bolts (index 27, 5/16"-18UNCx3/4"), and two washers (index 20, 5/16 flat washer)



Remove the support. And place lathe on floor.

Set Up

Step 5 – Install the Front Wheel Assembly

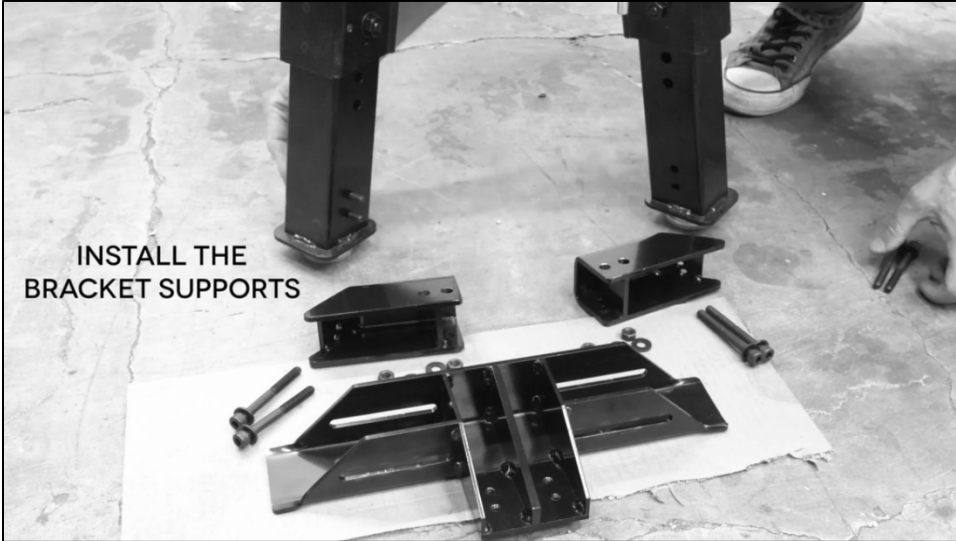

Start by organizing the needed parts and proceed to mount the two other side brackets if you have not done so yet.



Place the front wheel bracket (29) on the slide brackets.

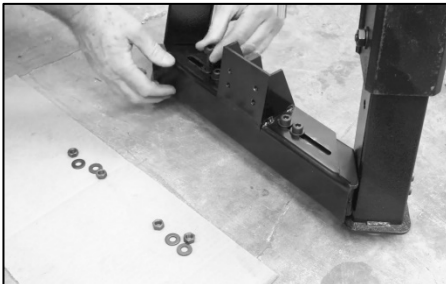

Drop in the four bolts with one washer before each bolt, and then another washer before the nut, like this:

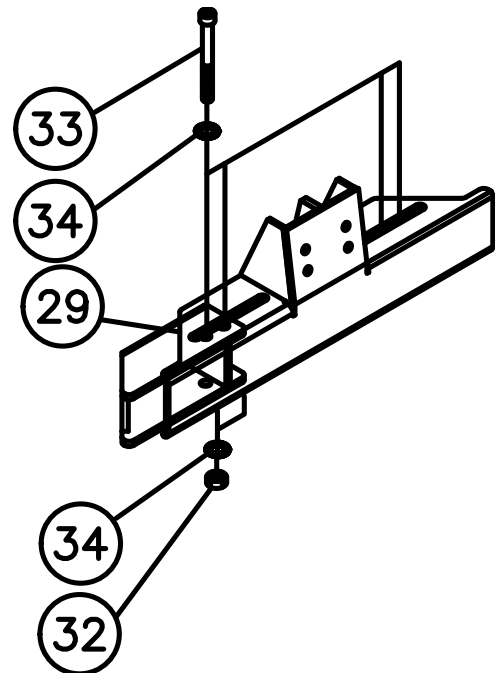

Tighten all hardware.

Set Up

Step 5 – Install the Front Wheel Assembly



Sandwich the spring between the wheel and the foot lever prior to installing to the front wheel assembly.



Screw on the wheel

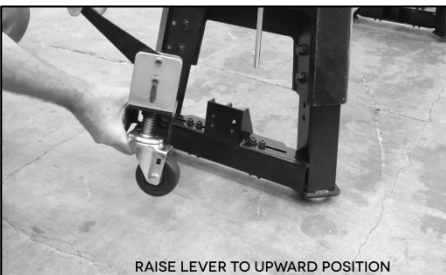

Raise the Lever to force the wheel to the most upward position.



Mount the wheel to the bracket with the four screws (27) and four washers (index 5)

Finished assemblies:

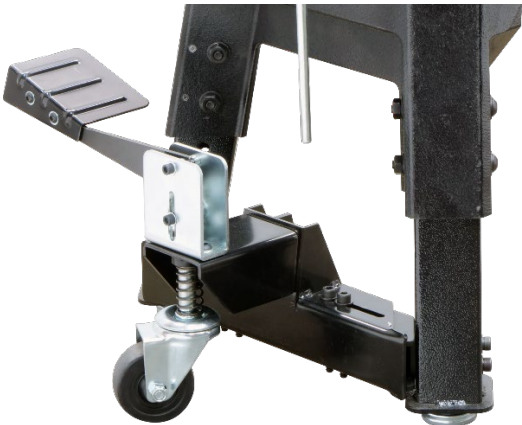

Adjustments

PRECISE
POSITION

The 1520 Lathe is equipped with a precise position function that allows you to ensure center to center contact between the spindle and quill.



The adjustment is simple.

1. Loosen the four Allen screws.
2. Lock down the tailstock.
3. Lock quill
4. Adjust center to center alignment
5. Fasten the four Allen screws.

Maintenance

⚠ WARNING! Never perform and setup, maintenance or adjustments with the machine connected to the power source!

⚠ WARNING! If you have any doubt about the described procedure, seek professional assistance. Do not attempt any procedure that you feel is unsafe, or that you do not have the physical capability of achieving.

⚠ WARNING! When removing banding, extreme caution must be used as the banding will spring when cut.

⚠ CAUTION! The machine is heavy. Ensure that you have enough people to do the job safely.

TECH TIP ⚙ There may be sawdust in or around your new machine as a result of thorough testing.

General

Keep your machine clean. At the end of each day, clean the machine. Wood contains moisture, and if sawdust or wood chips are not removed they will cause rust. In general, we recommend that you only use a Teflon-based lubricant on the lathe. Regular oil attracts dust and dirt. Teflon lubricant tends to dry and has less of a tendency to accumulate dirt and saw dust. Periodically check that all nuts and bolts are tight.

Drive belt

The drive belt should last for many years (depending on the usage) but needs to be inspected regularly for cracks, cuts and general wear. If damage is found, replace the belt.

Bearings

All bearings are sealed for life and do not require any maintenance. If a bearing becomes faulty, replace it.

Rust

The lathe is made from steel and cast iron. All none-painted surfaces will rust if not protected. It is recommended that they be protected by applying wax or a Teflon- based lubricant to them.

Lathe will not start.

1. Check that the start switch is in the correct position.
2. Check that the electrical power cord is plugged into the power outlet.
3. Check that the electrical supply is on (reset the breaker).
4. With the power disconnected from the machine, check that the wiring to the plug is correct.
5. Check that the rubber insulation is stripped enough and is not causing a bad connection. Check that all the screws are tight.

4. Power line overloaded. Correct overloaded condition.
5. Low voltage. Correct low voltage condition.

Squeaking noise.

1. Check the bearings
2. Check the drive belt is tensioned correctly.

Spindle slows down during a cut.

1. Dull cutting tools. Replace the tool or have it re-sharpened.
2. Feeding the wood too fast. Slow down the feed rate.
3. Oil or dirt on the drive belt. Clean or replace the drive belt.
4. Drive belt loose. Re-tension drive belt.

The machine will not stop.

This is a very rare occurrence as the machine is designed to be fail-safe. If it should occur and you cannot fix the fault, seek professional assistance. The machine must be disconnected from the power and never run until the fault has been rectified.

1. The stop switch is faulty. Replace the stop switch.

Motor tries to start but will not turn.

1. With the power disconnected from the machine, try to turn the spindle by hand. If the spindle will not turn, check the reason for jamming.
2. Capacitor faulty. Replace the capacitor. (N/A for MLAREVO1216EVS)
3. Motor faulty. Replace the motor.

Machine vibrates.

1. Machine not level on the floor. Re-level the machine ensuring that it has no movement.
2. Damaged drive belt. Replace the belt.
3. Job is not balanced. Change to slower speed and/ or balance the job.
4. Damaged pulley. Replace the pulley.
5. Worn spindle bearing. Replace the bearing.

Digital Read Out (DRO) is displaying an error.

Err1:Over-current mode

If the operating current of the motor exceeds 18 Amps for 30 seconds, the control board goes into Over-current protection mode.

Over-current mode is to stop the motor immediately and the display shows Err1.

Release the Over-current mode steps:

- Press the stop button to release the Over-current mode.
- Press the Start button again and the control board restarts the motor.

Err2: Motor work fail mod

After pressing the start button, if the motor is not running after 25seconds, the control board enters the Motor work fail mode

In the motor work fail mode, the control board immediately stops the motor operation and the display shows Err2.

Release the Motor work fail mode steps:

- Press the stop button to release the Motor work fail mode.
- Press the Start button again and the control board restarts the motor.

Err3:Spindle work fail mode

After pressing the start button, if the control board detects that the spindle is not running for 30 seconds after the motor runs normally, it will enter the Spindle work fail mode.

In the Spindle work fail mode, the control board immediately stops the motor operation and the display shows Err3.

Release the Spindle work fail mode steps:

- Press the stop button to release the Spindle work fail mode.
- Press the Start button again and the control board restarts the motor.

Wiring

Wiring

⚠ WARNING: VOLTAGE. Before connecting this tool to a power supply (receptacle, outlet, etc.) make sure that the voltage supplied is the same that is specified on the nameplate of the tool. **IF IN DOUBT, DO NOT PLUG IN THE MACHINE.** Using this tool with a voltage different than that stated on the nameplate can damage the electrical components of this machine and any such damage will not be covered by a warranty.

⚠ WARNING: CIRCUIT BREAKER. Also make sure that the power supply is equipped with the appropriate breaker and plug according to your local electrical code. To do this, first check the motor plate to get the FLA amperage of the machine, if worn out or not present refer to the specifications sheet. If there is any doubt in choosing the appropriate circuit breaker, please consult an electrician or an electrical supply source.

⚠ WARNING: ELECTRICAL SHOCK. It is extremely dangerous to work on live wires and/or electrical systems that are connected to a power source. **ALWAYS** disconnect the power from the machine prior to performing any maintenance or adjustments work.

⚠ WARNING: MOTOR WIRING: The information in this manual was current at the time of printing but may be different than the diagram on your machine. **ALWAYS** use the supplied wiring diagram with the machine or motor (under the electrical covering) if present.

Customer Support: (949)-474-1200 or customerservice@laquatools.com

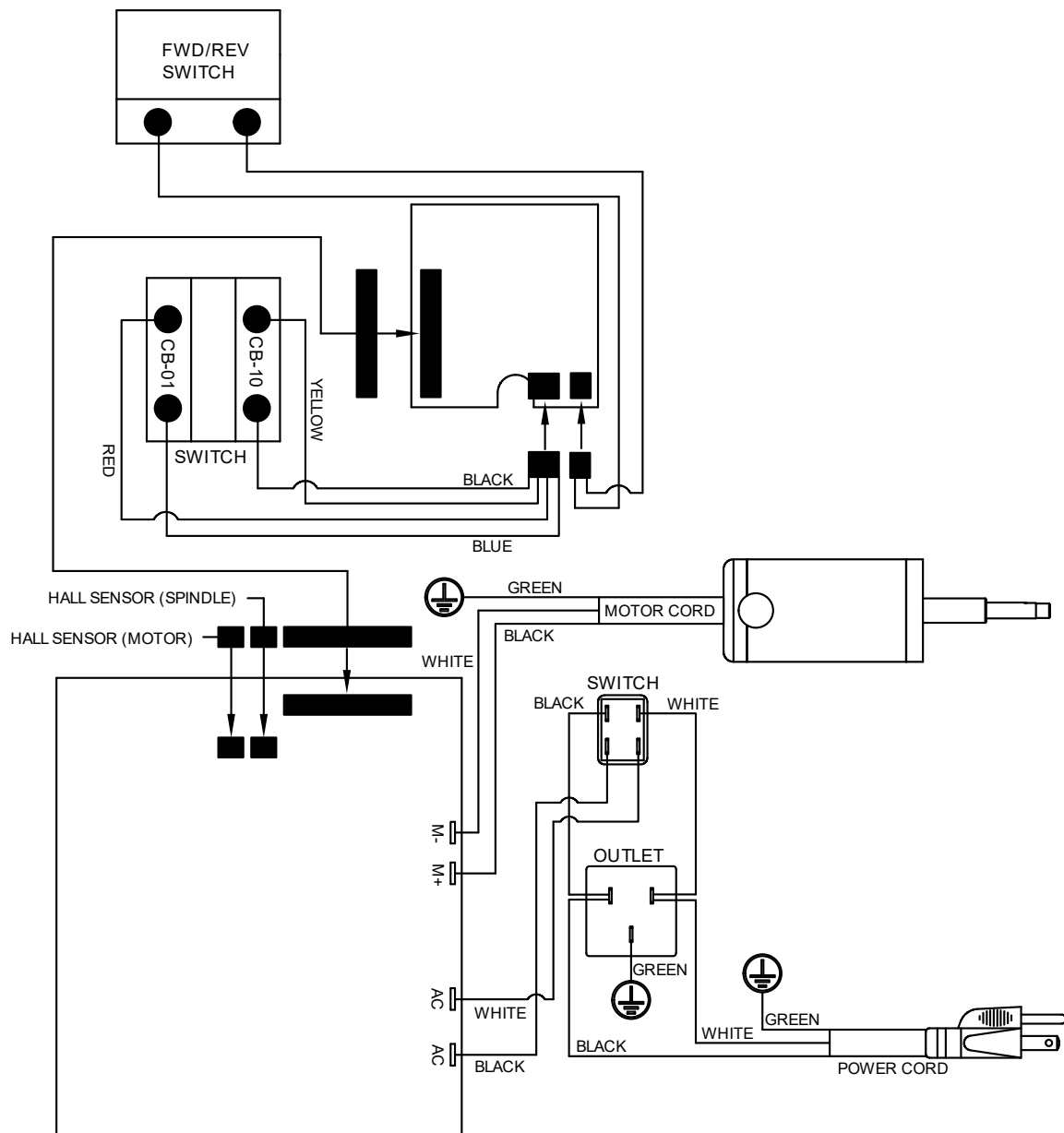

Parts

⚠ WARNING: Never perform and setup, maintenance or adjustments with the machine connected to the power source!

TECH TIP Only use authentic Laguna Tools parts for replacements.

Customer Support: (949)-474-1200 or customerservice@lagunatools.com

HeadStock

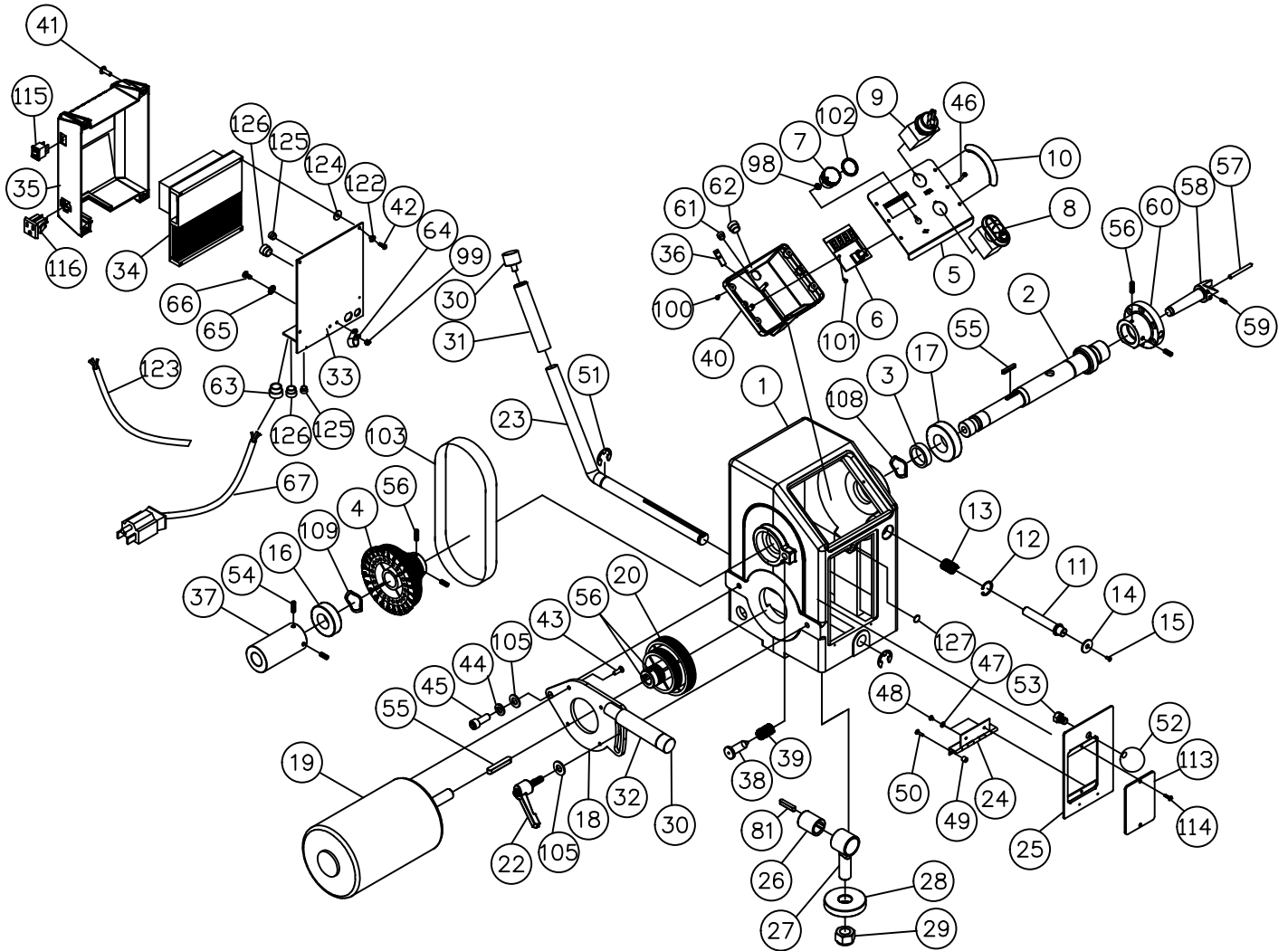

Tailstock, Banjo, Tool Rest

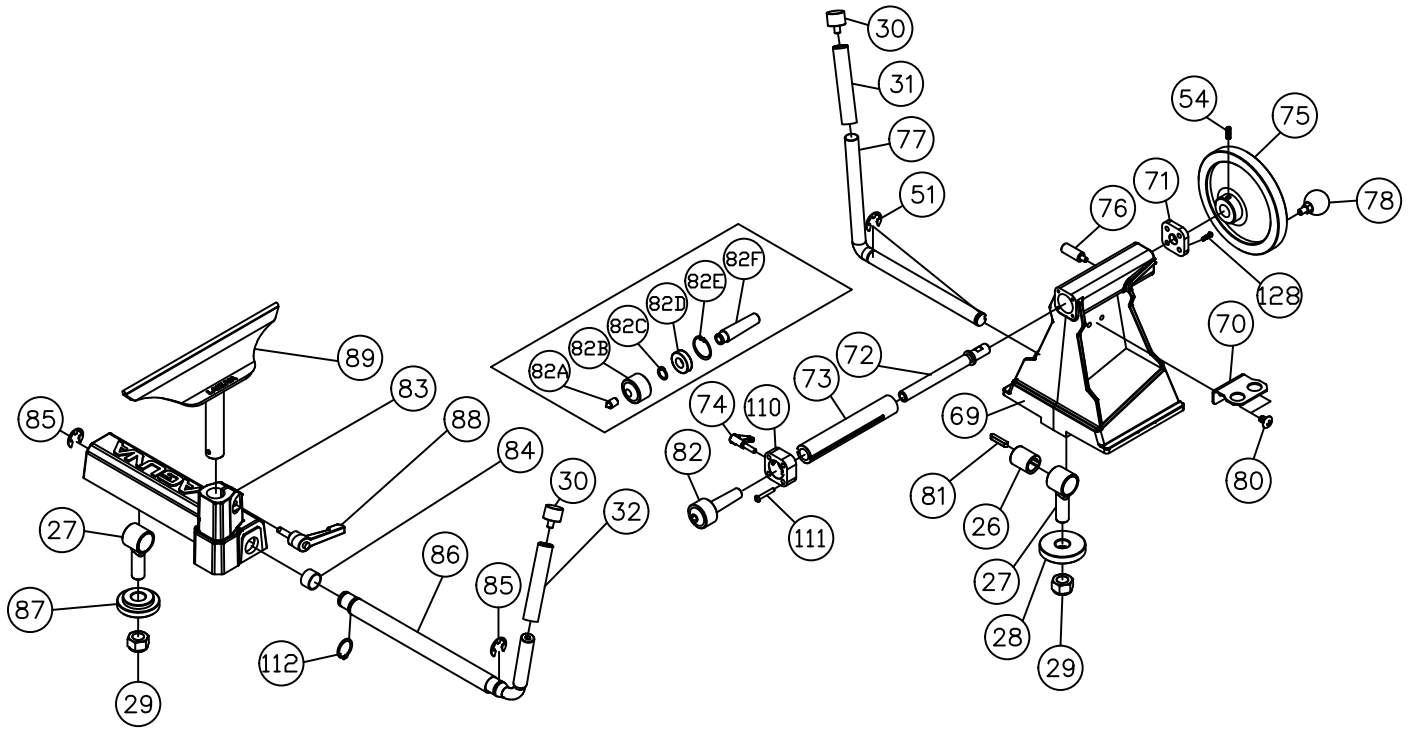

Bed & Leg Assembly

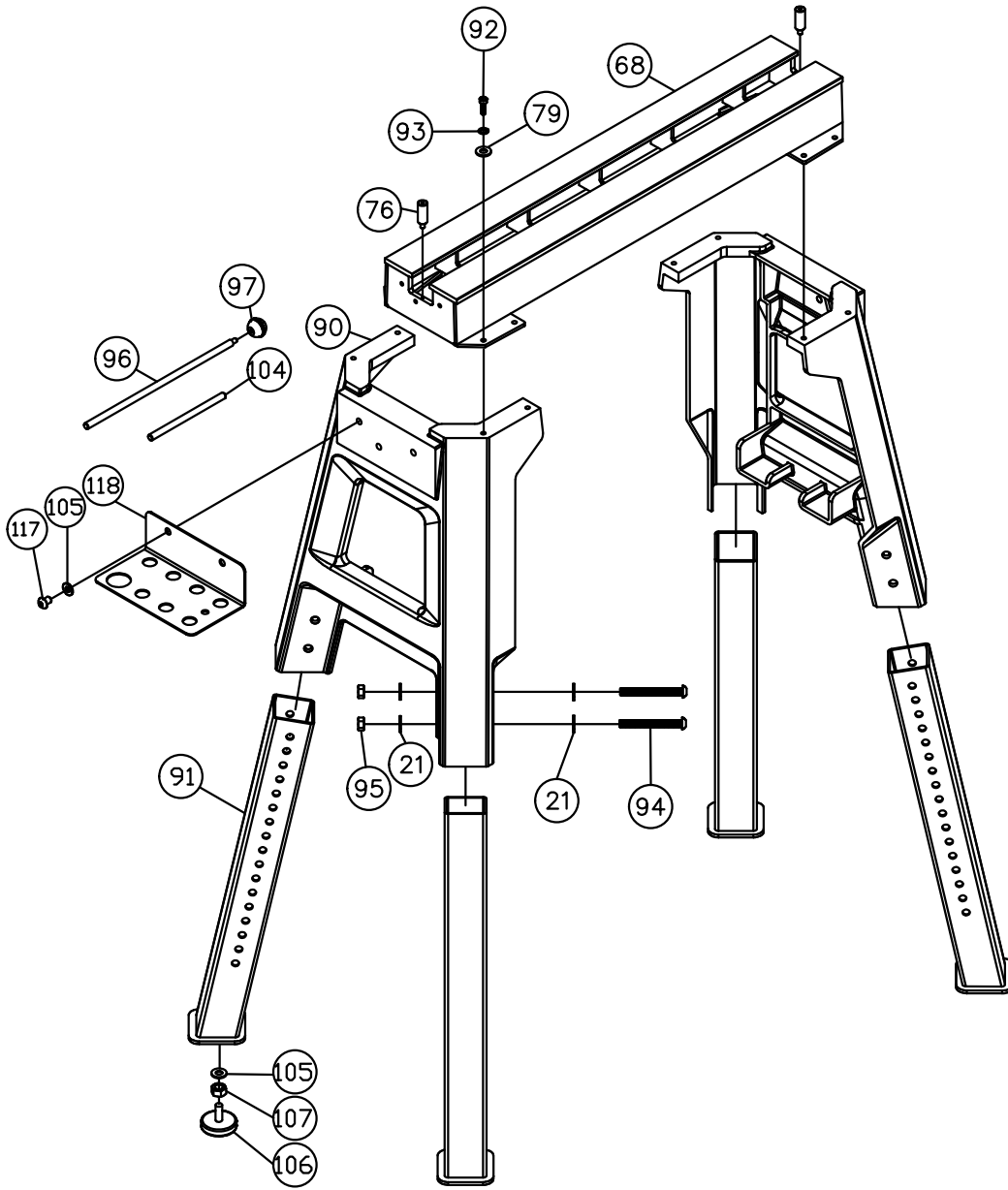

Parts

Parts Table

INDEX.....	PART NUMBER.....	DESCRIPTION.....	SPECIFICATION.....	QTY
1.....	415241-101.....	Headstock.....		1
2.....	415241-102.....	Spindle.....		1
3.....	PLAREVO1216-109.....	Magnetic Ring.....		1
4.....	PLAREVO1216-113.....	Spindle Pulley.....		1
5.....	415241-105.....	Control Panel.....		1
6.....	PLAREVO1216-131.....	Digital Readout.....		1
7.....	PLAREVO1216-139.....	Speed Knob.....		1
8.....	PLAREVO1836-170.....	ON/ OFF Switch.....		1
9.....	415241-109.....	Fwd/Rev Switch.....		1
10.....	PLAREVO1836-1129.....	Handle.....		2
11.....	415241-111.....	Spindle Lock Plunger.....		1
12.....	PLAREVO1836-191.....	C-Ring.....	R22.....	1
13.....	PLAREVO1836-103.....	Spring.....		1
14.....	PLAREVO1836-132.....	Disc, Spindle Lock.....		1
15.....	PLAREVO1836-1141.....	Socket Flat Head Screw.....	M3x8.....	1
16.....	PLAREVO1836-175.....	Ball Bearing.....	6205LLU.....	1
17.....	415241-117.....	Ball Bearing.....	6206LLU.....	1
18.....	415241-118.....	Motor Plate.....		1
19.....	415241-119.....	DC Motor.....		1
19A.....	PLAREVO1216-158A.....	Magnetic Ring.....		1
19B.....	415241-119B.....	Carbon Brush.....		2
19C.....	415241-119C.....	Motor Sensor.....		1
20.....	PLAREVO1216-154.....	Motor Pulley.....		1
21.....	415241-121.....	Flat Washer.....	D10xD23x2t.....	16
22.....	PLAREVO1836-120.....	Lock Handle.....		1
23.....	PLAREVO1836-111.....	Headstock Locking Handle.....		1
24.....	415241-124.....	Door Hinge.....		1
25.....	415241-125.....	Door.....		1
26.....	PLAREVO1836-115.....	Sleeve.....		2
27.....	PLAREVO1836-114.....	Clamp Bolt.....		3
28.....	PLAREVO1836-119.....	Clamp.....		2
29.....	PLAREVO1836-1110.....	Nylon Insert Lock Nut.....	M18x2.5.....	3
30.....	PLAREVO1836-1145.....	Cap.....		4
31.....	PLAREVO1836-116.....	Rubber Sleeve.....		2
32.....	PLAREVO1836-160.....	Rubber Sleeve.....		2
33.....	415241-133.....	Bottom Plate, Control Board Box.....		1
34.....	415241-134.....	Control Board.....		1
35.....	415241-135.....	Cover, Control Board Box.....		1
36.....	415241-136.....	Digital Readout Sensor.....		1
37.....	PLAREVO1216-117.....	Handwheel.....		1
38.....	PLAREVO1216-118.....	Index Pin.....		1
39.....	PLAREVO1216-119.....	Spring.....		1
40.....	415241-140.....	Control Box.....		1
41.....	415241-141.....	Screw.....	M4x12.....	4
42.....	PLAREVO1836-1104.....	Screw.....	M3x8.....	4
43.....	415241-143.....	Phillips Flat Head Screw.....	M5x15.....	4
44.....	PLAREVO1836-1115.....	Lock Washer.....	3/8".....	1
45.....	PLAREVO1836-195.....	Socket Head Cap Screw.....	3/8-16UNCx1".....	1
46.....	PLAREVO1216-135.....	Socket Head Button Screw.....	M3x20.....	2
47.....	PLAREVO1836-1109.....	Flat Washer.....	D3xD8x1t.....	2
48.....	PLAREVO1836-1107.....	Screw.....	M3x4.....	2

Parts

49	PLAREVO1836-1128	Spacer		2
50	PLAREVO1836-1127	Screw	M3x12	2
51	PLAREVO1836-189	E-Ring	E15	4
52	PLAREVO1836-117	Knob		1
53	PLAREVO1836-193	Hex Cap Screw	3/8-16UNCx1/2"	1
54	PLAREVO1836-1119	Set Screw	1/4-20UNCx3/8	3
55	PLAREVO1216-107	Key	5x5x25	2
56	PLAREVO1836-1101	Set Screw	1/4-20UNCx1/4	6
57	PLAREVO1836-1140	Thimble		1
58	PLAREVO1836-124	Spur Center		1
59	PLAREVO1836-1124	Set Screw	M6x6	1
60	PLAREVO1836-113	3" Faceplate		1
61	PLAREVO1216-189	Strain Relief	SB5M-2	1
62	PLAREVO1216-190	Strain Relief	6P-4	1
63	PLAREVO1836-1117	Strain Relief	7N-2	1
64	415241-164	Cord Holder		1
65	PLAREVO1216-193	Washer, Lock-Int. Tooth	#10	2
66	PLAREVO1216-197	Screw	#10-32UNFx1/2"	2
67	415241-167	Power Cord		1
68	415241-168	Bed		1
69	415241-169	Tailstock		1
70	PLAREVO1216-176	Tailstock Tool Caddy		1
71	415241-171	Adjusting Block		1
72	415241-172	Lead Screw		1
73	415241-173	Quill		1
74	PLAREVO1216-173	Lock Handle		1
75	415241-175	Handwheel		1
76	PLAREVO1216-174	Stop Bolt		3
77	415241-177	Tailstock Locking Handle		1
78	PLAREVO1836-181	Knob		1
79	415241-179	Flat Washer	D8xD18x2t	8
80	PLAREVO1836-1122	Screw	5/16-18UNCx1/2"	2
81	PLAREVO1836-185	Key	6x6x30	2
82	PLAREVO1216-168	Live Center Assembly		1
83	415241-183	Tool Rest Support Base		1
84	PLAREVO1836-183	Bushing		1
85	PLAREVO1836-188	E-Ring	E19	2
86	415241-186	Tool Rest Locking Handle		1
87	PLAREVO1836-1135	Clamp		1
88	PLAREVO1836-153	Lock Handle		1
89	415241-189	12" Tool Rest		1
90	415241-190	Leg		2
91	415241-191	Tube, Leg		4
92	PLAREVO1836-197	Socket Head Cap Screw	5/16-18UNCx1"	8
93	415241-193	Lock Washer	5/16"	8
94	415241-194	Socket Head Button Screw	M10x90	8
95	415241-195	Nut	M10	8
96	415241-196	Knockout Rod		1
97	PLAREVO1216-1104	Knob		1
98	PLAREVO1216-1105	O-Ring	P12	1
99	415241-199	Nut	#10-32UNF	2
100	415241-1100	Screw	M3x6	4
101	PLAREVO1216-1110	Pan Head Self-Tapping Screw	M3x8	2

Parts

102.....	PLAREVO1216-138	O-Ring	P22	1
103.....	415241-1103	Poly- V Belt	PJ6-180.....	1
104.....	PLAREVO1836-1136.....	Handle, Faceplate.....		1
105.....	PLAREVO1836-1112.....	Flat Washer.....	D10xD23x2t	8
106.....	415241-1106	Leveling Foot.....		4
107.....	PLAREVO1836-1111	Hex Nut	3/8-16UNC	4
108.....	PLAREVO1216-110	Wave Washer	6202	1
109.....	PLAREVO1836-184	Wave Washer	6205	1
110.....	415241-1110	Adjusting Block		1
111.....	415241-1111	Socket Head Button Screw	3/16-24UNCx1-1/4"	4
112.....	415241-1112	C-Ring	S25	1
113.....	415241-1113	Tracking Window		1
114.....	PLAREVO1836-1152.....	Screw	M4x6	2
115.....	415241-1115	Main Switch		1
116.....	415241-1116	Outlet.....		1
117.....	PLAREVO1836-1126.....	Socket Head Button Screw	3/8-16UNCx5/8"	2
118.....	PLAREVO1836-150	Tool Caddy		1
122.....	415241-1122	Bushing		4
123.....	415241-1123	Control Cord.....		1
124.....	415241-1124	Nylon Washer		4
125.....	415241-1125	Strain Relief	SB5M-1.....	2
126.....	PLAREVO1836-1138.....	Strain Relief	6N-4.....	2
127.....	PLAREVO1836-1151.....	Magnet		1
128.....	415241-1128	Socket Head Button Screw	3/16-24UNCx1/2"	1

OPTIONAL Wheel System

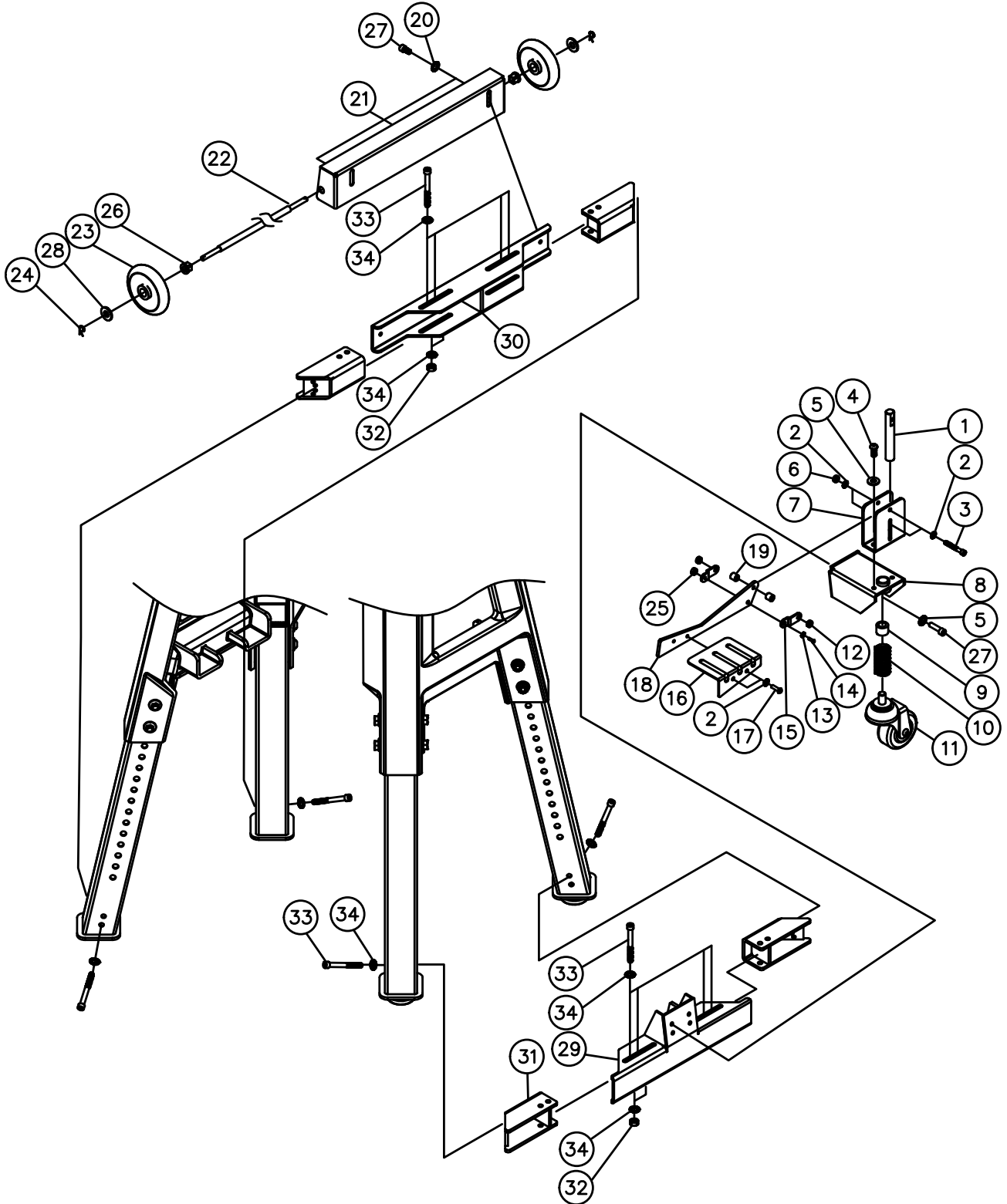

INDEX.....	PART NUMBER.....	DESCRIPTION.....	SPECIFICATION.....	QTY
1.....	PBAND1412-175-6-1.....	Rod.....		1
2.....	PBAND1412-175-6-2.....	Flat Washer.....	1/4".....	6
3.....	PBAND1412-175-6-3.....	Socket Head Cap Screw.....	1/4"-20UNCx1-3/4".....	2
4.....	PBAND1412-175-6-4.....	Socket Head Button Screw.....	5/16"-18UNCx1/2".....	2
5.....	PBAND1412-175-6-5.....	Flat Washer.....	5/16".....	6
6.....	PBAND1412-175-6-6.....	Nylon Inserted Lock Nut.....	1/4"-20UNC.....	2

Parts

7	PBAND1412-175-6-7	Fixed Plate		1
8	PBAND1412-175-6-8	Wheel Bracket		1
9	PBAND1412-175-6-9	DU Bearing	MB1620DU	1
10	PBAND1412-175-6-10	Spring		1
11	PBAND1412-175-6-11	Caster		1
12	PBAND1412-175-6-12	Spacer		2
13	PBAND1412-175-6-13	Flat Washer	M5	1
14	PBAND1412-175-6-14	Screw	M5x0.8x20	1
15	PBAND1412-175-6-15	Connecting Plate		2
16	PBAND1412-175-6-16	Foot Pedal		1
17	PBAND1412-175-6-17	Socket Head Button Screw	1/4"-20UNCx3/8"	2
18	PBAND1412-175-6-18	Plate		1
19	PBAND1412-175-6-19	Spacer		2
20	415241-220	Flat Washer	5/16"	2
21	PBAND18BX2203-6-21	Support Plate		1
22	PBAND18BX2203-6-22	Rod		1
23	PBAND18BX2203-6-23	Wheel		2
24	PBAND18BX2203-6-24	Cotter pin	2x25mm	2
25	PBAND1412-175-6-25	Nylon Inserted Lock Nut	M5x0.8	1
26	PBAND18BX2203-6-26	Bushing		2
27	415241-227	Socket Head Cap Screw	5/16"-18UNCx3/4"	6
28	PBAND18BX2203-6-28	Flat Washer	1/2"	2
29	415241-229	Wheel Bracket		1
30	415241-230	Wheel Bracket		1
31	415241-231	Slide Bracket		4
32	415241-232	Hex Nut	5/16"-18UNC	8
33	415241-233	Socket Head Cap Screw	5/16-18UNCx3"	16
34	415241-179	Flat Washer	M8	24

OPTIONAL Expansion Set

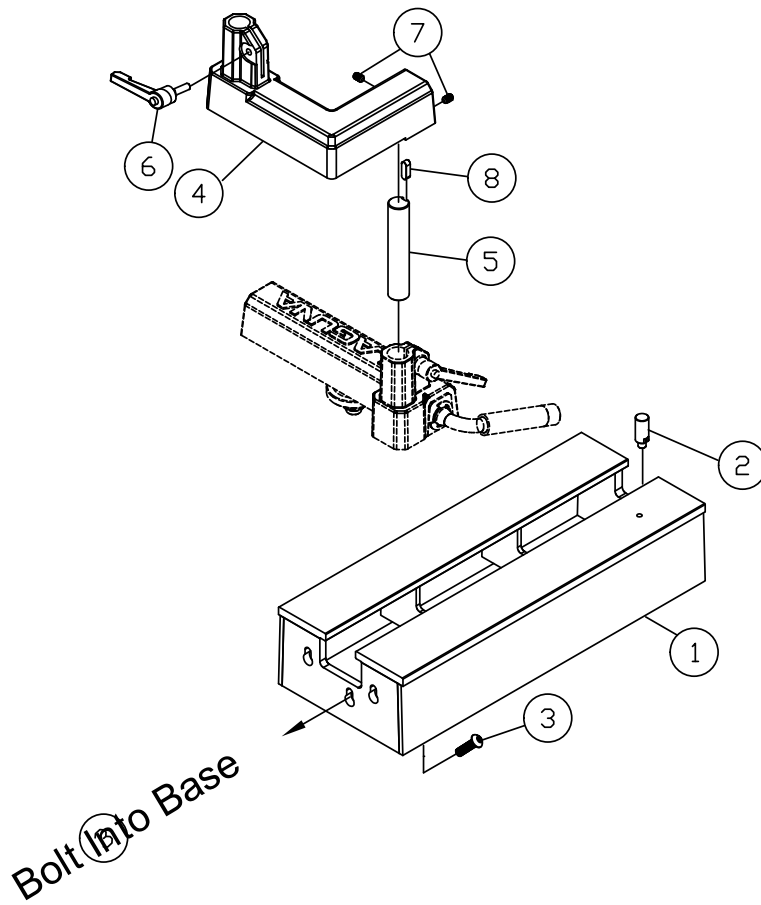

INDEX.....	PART NUMBER.....	DESCRIPTION	SPECIFICATION	QTY
1.....	PLAREVO1836-301	20" Bed Extension		1
2.....	PLAREVO1216-174	Stop Bolt		1
3.....	PLAREVO1836-303	Socket Head Button Screw	3/8-16UNCx1".....	3
4.....	415241-304.....	Tool Rest Support Base, Extension.....		1
5.....	415241-305.....	Shaft		1
6.....	PLAREVO1836-153	Lock Handle.....		1
7.....	415241-307.....	Set Screw	5/16-18UNCx1/2"	2
8.....	PLAREVO1836-186	Key.....	8x7x25	1

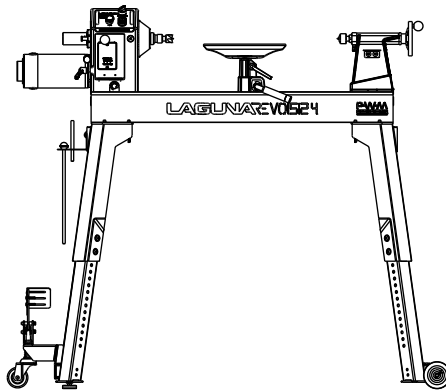

LAGUNA[®]

2072 Alton Parkway Irvine, CA 92606 U.S.A.

Service: +1 (949) 474-1200 or email customerservice@lagunatools.com

lagunatools.com

