

WALINGA[®]

INC.



Trailer



Truck

HIGH OUTPUT AUGER UNITS OPERATOR'S MANUAL



WALINGA[®]
INC.

Head Office:
RR#5
Guelph, Ontario, N1H 6J2
PHONE (888) 925-4642
FAX (519) 824-5651
www.walinga.com

FACTORY DISTRIBUTION AND SERVICE CENTRES:

IN CANADA:

- 70 3rd Ave. N.E. Box 1790 Carman, Manitoba Canada R0G 0J0
Tel (204) 745-2951 Fax (204) 745-6309

IN USA:

- 1190 Electric Ave. Wayland, MI. USA 49348
Tel (800) 466-1197 Fax (616) 877-3474
- 579 4th Street NW
Sioux Center, Iowa USA 51250
Tel (800) 845-5589 Fax (712) 722-1128

PRINTED IN CANADA
ISSUE DATE: Mar,2012 rev 07/14
REPRINT:
OM PART# 34-852276 v1.2 4242018



WHEEL NUT INSPECTION REPORT

Customer/Driver: This form must be filled out and returned to Walinga immediately upon delivery.

CHECK WHEEL NUT TORQUE AFTER FIRST 50-100 MILES OF SERVICE! TORQUE TO 500 FT-LBS

I have read this notice and I understand the importance of the instruction.

Customer Name: _____

Address _____

City, Prov./State _____

Date: ____ ____ ____

Driver/Customer Signature: _____

Walinga employee or delivery personnel:

- 1) Instruct driver or customer to sign Walinga Copy and Customer Copy
- 2) Return the Walinga Copy to Walinga.

In the US return to Walinga USA Inc. 1190 Electric Ave., Wayland, MI 49348
In Canada return to Walinga Inc, 5656 Highway 6N, Guelph, ON N1H 6J2

Walinga Copy



WHEEL NUT INSPECTION REPORT

Customer/Driver: This form must be filled out and returned to Walinga immediately upon delivery.

CHECK WHEEL NUT TORQUE AFTER FIRST 50-100 MILES OF SERVICE! TORQUE TO 500 FT-LBS

I have read this notice and I understand the importance of the instruction.

Customer Name: _____

Address _____

City, Prov./State _____

Date: ____ ____ ____

Driver/Customer Signature: _____

Walinga employee or delivery personnel:

- 1) Instruct driver or customer to sign Walinga Copy and Customer Copy
- 2) Return the Walinga copy to Walinga.

In the US return to Walinga USA Inc. 1190 Electric Ave., Wayland, MI 49348
In Canada return to Walinga Inc, 5656 Highway 6N, Guelph, ON N1H 6J2

Customer Copy

Dear Customer:

Thank you for choosing **WALINGA TRANSPORTATION EQUIPMENT**. For your convenience, should you require any information related to Parts, Service or Technical Engineering, please contact one of the following Walinga Personnel:

CANADIAN CUSTOMERS: 1-888 925-4642

TECHNICAL - ENGINEERING:

Janus Droog - Technical Field Support (ext: 259).....email:jad@walinga.com

WARRANTY CLAIMS:

Gary Nijenhuis: (ext:258)..... email:gary.nijenhuis@walinga.com

SERVICE MANAGER:

Andy Nijenhuis (ext:228)..... .email:andy@walinga.com

PARTS MANAGER:

Jack Lodder (ext: 224).....email: jel@walinga.com

Parts Department Fax: (519) 824-0367

CUSTOMERS IN USA: 1-800-466-1197

Fax (616) 877-3474

WARRANTY CLAIMS:

Jonathan Medemblik: (ext: 8).....email:jtm@walinga.com

PARTS MANAGER:

John VanMiddelkoop (ext: 3).....email: jvm@walinga.com

SERIAL NUMBER LOCATION:

The serial number plate is located on the Drivers Side of the unit, at the front of the body on the truck, and on the landing gear on trailers. Please mark the serial number and the date of manufacture of the body in the space provided for easy reference.

DATE OF MANUFACTURE: _____ / _____ / _____

SERIAL NUMBER: _____

V.I.N. PLATE LOCATION

Always give your dealer the V.I.N. (Vehicle Identification Number) of your Walinga Bulk Feed unit when ordering parts or requesting service or other information.

Please mark the number in the space provided for easy reference. Also obtain and mark down the Model Number, Production Year and other pertinent information of your Trailer/Truck unit in the spaces provided.

The plate is located where indicated.



Trailer (VIN Plate)



Truck (Serial Number Plate)

V.I.N. Number _____

Wheels _____

Model Number _____

Tires _____

Length _____

Date Purchased _____

Suspension _____

Dealer Purchased From _____

Axles _____

Address _____

HI OUTPUT AUGER UNLOAD (HOAG)BULK FEED UNIT

Warranty Registration Form & Inspection Report

WARRANTY REGISTRATION (3 part form - please print)													
<i>This form must be filled out by the dealer and signed by both the dealer and the customer at the time of delivery.</i>													
<i>Delivery Date: mm / dd / yyyy</i>													
<i>COMPANY / CUSTOMER NAME</i>	<i>DEALER NAME</i>												
<i>Phone</i>	<i>Phone</i>												
<i>Mobile phone</i>	<i>Mobile phone</i>												
<i>Email : @</i>	<i>Email : @</i>												
<i>Street Address</i>	<i>Street Address</i>												
<i>City Prov/State</i>	<i>City Prov/State</i>												
<i>Postal/Zip Country</i>	<i>Postal/Zip Country</i>												
<i>Truck Model</i>	<i>VIN Number</i>												
DEALER INSPECTION REPORT													
<input type="checkbox"/> Boom Swings Freely <input type="checkbox"/> Bottom, Vertical, and Boom Augers Turn Freely <input type="checkbox"/> Landing Gear Moves Freely and Crank Stowed <input type="checkbox"/> Air & Hydraulic Lines Properly stowed (no leaks) <input type="checkbox"/> Electrical Connections Stowed <input type="checkbox"/> Tires at Specified Pressure <input type="checkbox"/> Rims & Tires Torqued <input type="checkbox"/> Brakes Adjusted Properly	<table border="1" style="width: 100%; border-collapse: collapse;"> <tr> <td style="width: 20px;"><input type="checkbox"/></td> <td>Safety Signs Installed</td> </tr> <tr> <td><input type="checkbox"/></td> <td>Operator's Manual Supplied</td> </tr> <tr> <td><input type="checkbox"/></td> <td>All Reflectors Installed & Clean</td> </tr> <tr> <td><input type="checkbox"/></td> <td>All Lights Functioning</td> </tr> <tr> <td><input type="checkbox"/></td> <td>Brakes Release at Proper Pressure</td> </tr> <tr> <td><input type="checkbox"/></td> <td>Review Operating and Safety Instructions</td> </tr> </table>	<input type="checkbox"/>	Safety Signs Installed	<input type="checkbox"/>	Operator's Manual Supplied	<input type="checkbox"/>	All Reflectors Installed & Clean	<input type="checkbox"/>	All Lights Functioning	<input type="checkbox"/>	Brakes Release at Proper Pressure	<input type="checkbox"/>	Review Operating and Safety Instructions
<input type="checkbox"/>	Safety Signs Installed												
<input type="checkbox"/>	Operator's Manual Supplied												
<input type="checkbox"/>	All Reflectors Installed & Clean												
<input type="checkbox"/>	All Lights Functioning												
<input type="checkbox"/>	Brakes Release at Proper Pressure												
<input type="checkbox"/>	Review Operating and Safety Instructions												
<p>I have thoroughly instructed the buyer on the above described equipment which review included the Operator's Manual content, equipment care, adjustments, safe operation and applicable warranty policy.</p> <p>Date _____ Dealer's Rep. Signature _____</p>													
<p>The above equipment and Operator's Manual have been received by me and I have been thoroughly instructed as to care, adjustments, safe operation and applicable warranty policy.</p> <p>Date _____ Owner's Signature _____</p>													
<small>199 05132016</small>													

*3 Part Form
Please Print*

WHITE	YELLOW	PINK
WALINGA	DEALER	CUSTOMER

Walinga Inc. Warranty Terms

Engineered Transportation Equipment

Hopper Units

Walinga Inc. is committed to providing a quality product that will meet or exceed your expectations for many years to come. Our warranty terms and our warranty claim process has been designed to ensure that each warranty claim will be resolved in an orderly, fair and timely manner.

The Warranty

Walinga Inc. ("Walinga") warrants that all new engineered transportation products sold by Walinga Inc. will be free from defects in material and workmanship (the "Walinga Warranty").

Warranty Period

The warranty period for the Walinga Warranty shall expire one (1) year after the date of delivery to the original customer. The standard Walinga warranty period for hydraulic components shall expire one (1) year after the date of delivery to the original customer. This warranty period may be extended to expire three (3) years after the date of delivery to the original customer for hydraulic components which are installed on equipment that conforms to specific system and maintenance requirements – see the Warranty Conditions section of this document for details.

The Walinga warranty period for structural integrity of the equipment shall expire five (5) years after the date of delivery to the original customer.

Limitations of and exclusions from the Walinga Warranty

- The Walinga Warranty applies to material and workmanship only.
- With respect to any component parts that are supplied or manufactured by others, the warranty coverage on such component parts will be strictly limited to the warranties of the manufacturers of such component parts.
- The Walinga Warranty shall only be for the benefit of the original purchaser of the transportation equipment.
- A Walinga Warranty may be transferable by the original purchaser to a third party for the balance of the warranty period then remaining, provided that Walinga consents in writing to such transfer of warranty.
- The Walinga Warranty is conditional upon proper storage, installation, use, maintenance, operation and compliance with any applicable recommendations of Walinga.

Warranty Claim Procedure

Should you encounter any difficulties with your unit within its warranty period, please contact your local Walinga dealer or sales representative, your local Walinga Service department or Walinga's Warranty Department to submit a warranty claim application.

To speak with a Walinga Warranty Coordinator, contact:

- Canada 1-888-WALINGA (ext 258)
International +1-519-824-8520 (ext 258)
Email – warranty.canada@walinga.com
- USA 1-800-466-1197 (ext 8)
Email – warranty.usa@walinga.com
- Australia 07-4634-7344
Email – mail@customvac.com.au

Required Warranty Claim information

The following information must be provided to Walinga in order for us to properly process and consider your warranty application:

- Customer name and contact information (email if available).
- The equipment serial number and/or Vehicle Identification Number (if applicable).
- Date of claimed failure.
- Equipment mileage at the time of claimed failure.
- Details, description and photos (upon request) of the claimed failure and the corrective repairs attempted.

Warranty Conditions

- **Equipment must be registered within 30 days of being received by the buyer. It will be within the sole and unfettered discretion of Walinga as to whether it will honour its warranty on non-registered equipment.**
- The buyer is responsible for promptly notifying Walinga of any defects to the equipment. The buyer is also responsible for making the equipment available to Walinga or its authorized repair facility for evaluation and repair.
- Prior to making any repairs or parts replacements, a warranty application and any estimated associated costs must be approved with the issuance of a claim number by an authorized Walinga representative. Undertaking any work prior to receiving warranty authorization may result in a partial or complete loss of warranty coverage. (see over for page 2 -->)

(Continued from page 1)

- At Walinga's discretion, warranty repairs may be authorized to be completed at a repair facility convenient to the buyer. In such situations the estimated labour time must be approved by Walinga prior to undertaking any work. Labour hours will be reimbursed at the facilities posted hourly labour rate.
- At Walinga's request, parts in question must be returned to the nearest Walinga service facility for evaluation. In such situations a Returned Goods Authorization (RGA) number will be provided to the buyer. The returning shipment must be clearly labeled with the assigned RGA number and include a copy of the RGA form. Unless otherwise arranged, these parts are to be returned to Walinga within 30 days to ensure timely processing of your warranty claim. Failure to return such parts may result in partial or complete loss of warranty coverage.
- Replacement parts provided under warranty are covered for the remainder of the original equipment warranty period.
- Walinga reserves the right to use new, remanufactured or refurbished components when performing warranty repairs and replacements.
- Walinga is entitled to a reasonable amount of time and a reasonable number of attempts to assess the claim, diagnose the problem, and perform any necessary repairs.
- The three (3) year warranty offering on hydraulic components is strictly limited to defects in a hydraulic system which meets the following criteria:
 - The hydraulic system is powered exclusively by a Walinga supplied hydraulic wet line kit which has been deemed appropriate by Walinga to meet the specific system requirements.
 - Include a Walinga installed Full Auto-Unload HMI package.
 - Exclusively use Petro-Canada Hydrex VX - All-Season hydraulic oil.
 - All replacement components and maintenance consumables are supplied by Walinga.
 - The customer can provide recorded evidence that equipment maintenance is performed in accordance with Walinga's prescribed maintenance requirements as they are outlined in the equipment Operator's Manual.
- The five (5) year warranty on structural integrity applies specifically to structural defects in the following components:
 - The tank structure - including the base, dividers, side sheets, roof and lid(s).
 - The discharge system structure - including the trough tunnel, the vertical, the boom and the discharge rotation system; but not including internal wear to the augers and/or the auger housing resulting from normal, everyday use.
 - All structural components intended to support the rotation and discharge system.
 - The bogie frame structure - excluding the suspension system; which is limited to the manufacturers warranty offering.
- The warranty offered on used or refurbished equipment is limited to that specified on the purchase contract. Where a warranty period has not been stipulated on the purchase contract, and where such equipment is "used", then such equipment is considered by Walinga to be sold "as is, where is" without the Walinga Warranty.

Without limitation, Walinga reserves the right to reject a warranty claim or for any one or more of the following reasons:

- The warranty claim information provided is insufficient.
- The product evaluation does not substantiate the claim.
- The unit has been operated above and beyond its capacity or not maintained or serviced properly, resulting in damages incurred to major components.
- It is apparent that the operator's manuals have not been followed
- The equipment is not registered

Without limitation, Walinga's Warranty does not cover:

- Damage or deterioration due to lack of reasonable care or maintenance.
- Damage caused or affected by unapproved modifications to the equipment.
- Damage caused by negligence or misuse of the equipment.
- Damage caused by using the equipment for purposes for which it was not designed or intended.

Walinga's liability under this warranty, whether in contract or tort, is limited to the repair, replacement or adjustment of defective materials and workmanship. In no event will Walinga be responsible for any direct, indirect, loss of time, incidental or consequential expenses including, but not limited to, equipment rental expenses, towing, downtime, inconvenience, or any losses resulting from the inability to use the equipment. Further, Walinga shall not be liable for any damages or inconvenience caused by any delay in the supply or delivery of any equipment or component parts thereof.

The selling Dealer/Sales Person makes no warranty of its own and has no authority to make any representation or promise on behalf of Walinga, or to modify the terms or limitations of the Walinga Warranty in any way.

Punitive, exemplary or multiple damages may not be recovered unless applicable law prohibits their disclaimer.

Warranty related claims may not be brought forward as a class representative, a private attorney general, a member of a class of claimants or in any other representative capacity.

The Walinga Warranty and all questions regarding its enforceability and interpretation are governed by the law of the country, state or province in which you purchased your Walinga equipment. The laws of some jurisdictions limit or do not allow the disclaimer of consequential damages. If the laws of such a jurisdiction apply to any claim against Walinga, the limitations and disclaimers contained here shall be to the greatest extent permitted by law.

Hydraulic System Start Up Procedure HA(T) & HS(T)

1. Check the hydraulic oil level and inspect for any hydraulic leaks on the truck and/or trailer. Ensure that the wet line couplers are tight. The female coupler should be turned down until the edge of the coupler reaches the scribed line in male twist couplers.
2. Before beginning to unload product, particularly in temperatures below 32 degrees Fahrenheit (0 degrees Celsius), ensure that the oil has been adequately warmed at idle speed. Cold oil will result in higher start up pressures and damage to hydraulic components.
3. Always position the boom over the bin or the customers' feed storage at idle speed. Positioning the boom at a higher engine speed may result in damage to the equipment.
4. Do not move the trailer with the boom out of saddle or when the boom is full of product. Always empty the boom prior to repositioning. Moving the trailer with the boom out of the saddles may cause major damage to the boom, and upper vertical assembly.
5. Unload the unit starting at the compartment closest to the outlet end of the trough (rear → front for rear unload units and front → rear for front unload units); **emptying one compartment at a time**. Leave the gates in the empty compartments open to reduce the pressure at the trough auger motor. Unloading product below closed gates will result in higher than necessary trough auger motor pressures and may cause damage and excessive wear to the trough liner. This will also put outward pressure on the gates; eventually reducing their ability to achieve a tight seal.
6. When unloading is completed, lower the engine speed to an idle to prevent the augers from becoming warped or bent. Note: while unloading, it is the product surrounding the augers which act as a cushion and help keep the augers centered.
7. Always close the gates after all unloading is completed, and before reloading with product. The trough auger must be empty at start-up.
8. **Do not leave the controls unattended while unloading!** If not shut down immediately, severe damage may be done to the hydraulic pump(s) and pressure relief valve(s) if the system is allowed to operate over the relief pressure setting for an extended period of time.

SERVICE RECORD

MAINTENANCE		HOURS												
		SERVICED BY												
DAILY														
CK	tire pressures													
	condition of hydraulic filters													
D	Drain moisture from air tanks													
WEEKLY														
G R E A S E	boom cylinder pins													
	boom pivot													
	upper vertical bearing clamp													
	lower vertical rotation													
	vertical rotation pilot ring													
	drive Shaft U-joints													
	slack adjusters and S-cam shafts													
CK	hub oil level (if applicable)													
RET	Re-torque wheel, suspension & landing gear													
	Re-torque kingpin plate fasteners													
MONTHLY														
G R E A S E	Trough Auger Bearings													
	Stuffer Auger Bearings													
	Vertical Auger Bearings													
	Boom Auger Bearings													
	Landing Gear Bearings													
C	Clean & Inspect Jumper Cords & Plugs													
LUB	Jumper Cords & Plugs Use dielectric grease.													
	S-Cams, Slack Adjusters													
	Suspension components (See vendor requirements)													
INS	Inspect Brake Components (Brake Chambers, Pad Wear, S-Cams, Slack Adjusters)													
	Inspect Wheel Ends for leaks													
V	Verify Safety Labels are Present & Legible													

CK = CHECK

RET = RE-TORQUE

LUB = LUBRICATE

INS = INSPECT

See Lubrication and Maintenance Sections for details of service. Copy these pages to continue the record.

(SEE OVER FOR PART TWO CONTINUATION OF SERVICE RECORD)

(CONTINUATION OF SERVICE RECORD FROM PREVIOUS PAGE)

		HOURS																			
BY		SERVICED																			
MAINTENANCE																					
EVERY 3 MONTHS																					
I N S P E C T	air system for leaks and hose abrasion																				
	electrical system and wiring for damage																				
	for proper operation of all lights & functions																				
	Wheel Ends for smooth/quiet rotation																				
	braking system for damage and wear																				
	all Suspension Components																				
	the body, frame and structural components																				
EVERY 6 MONTHS																					
T E S T	hydraulic pump flow																				
	the hydraulic cooler fan for proper operation																				
	test and inspect the disinfectant sprayers for proper operation																				
I N S P E C T	for leaks in the hydraulic system																				
	hydraulic hoses for breakdown or abrasions																				
	trough and boom hanger bearings																				
CL	Clean the radiator on the hydraulic oil cooler																				
	Open electrical junction boxes & inspect for loose connections. Lubricate with dielectric grease.																				
D I S & L U B	Disassemble & Lube the splines at the hydraulic pump/ PTO																				
	Disassemble and Lube Trough Motor Spline Insert																				
	Disassemble and Lube Vertical Motor Spline Insert																				
	Disassemble and Lube Boom Motor Spline Insert																				
LUB	Rotation Motor and Crown Gears																				
REP	Replace all hydraulic filters																				
ANUALLY																					
REP	Replace Hydraulic System Oil																				

CK = CHECK CL = CLEAN
LUB = LUBRICATE REP = REPLACE

See Lubrication and Maintenance Sections for details of service. Copy these pages to continue the record.

LUBRICATION SCHEDULE FOR HOPPER AUGER TRAILER

No	Description	Location on Body	# of Fittings	Frequency
1	Trough Auger Bearings	Front & Rear	2	Monthly
2	Vertical Auger Bearings	Top & Bottom Vertical Auger	2	
3	Boom Auger Bearings	Front & Rear Boom	2	
4	Boom Cylinder	Top Rear	2	Weekly
5	Boom Pivot	Top Rear	4	
6	Upper Vertical Bearing	Top Vertical Boom	2	
7	Lower Vertical Rotation	Bottom Vertical Boom	2	
8	Gear Rotation Pilot Ring	Lower Vertical Boom	4	
9	Trough Splined Motor Insert	Rear Trough	Disassemble and lube with HD EP gear grease every 6 months.	
10	Vertical Splined Motor Insert	Bottom Vertical Boom		
11	Boom Splined Motor Insert	Rear Boom Auger		
12	Boom Rotation Gear	Rear Boom	Remove cover and lube with HD EP gear grease every 6 months.	

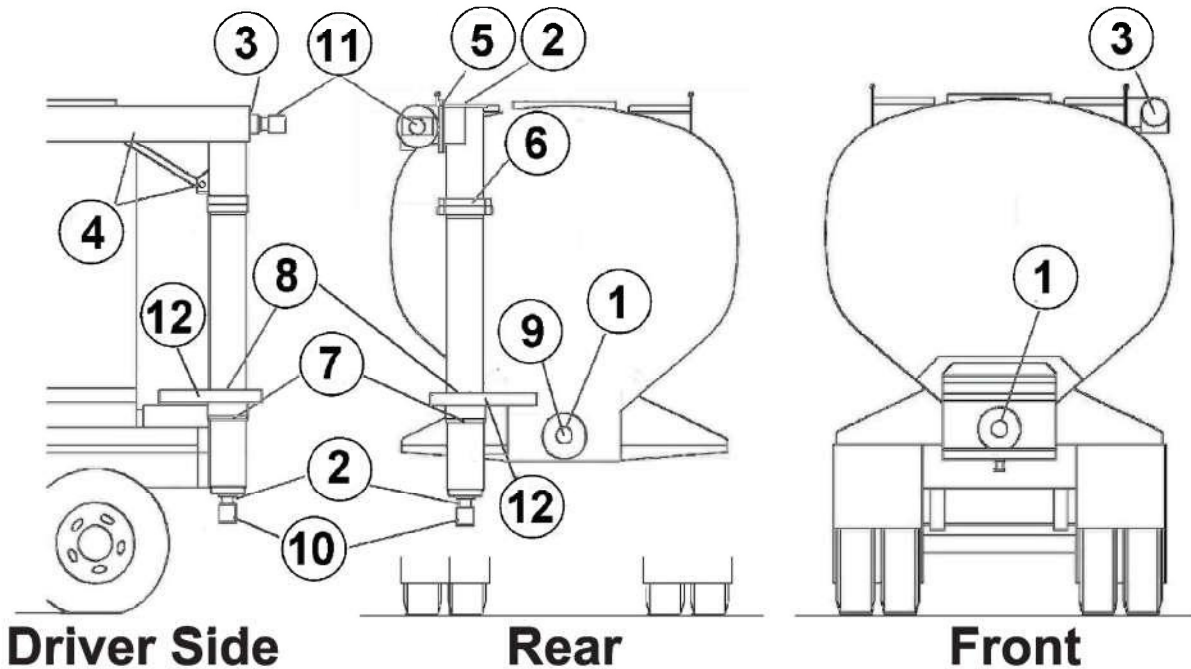

53-115206-6 rev.A

TABLE OF CONTENTS

SECTION PAGE	DESCRIPTION
1	Introduction 9
2	Safety 10
2.1	General Safety 11
2.2	Operating Safety 12
2.3	Unloading Safety 12
2.4	Maintenance Safety 13
2.5	Hydraulic Safety 13
2.6	Travel Safety 14
2.7	Tire Safety 14
2.8	Safety Signs 14
2.9	SignOff Form 15
3	Safety Sign Locations 16
4	Operation Guidelines 21
4.1	To the New Operator or Owner 21
4.2	Terminology 22
4.3	Break-In 23
4.4	Pre-Operation Vehicle Inspection Procedure 25
4.5	Hooking Up/Unhooking 28
4.5.1	Hooking Up 28
4.5.2	Unhooking 30
4.6	Controls 31
4.7	Machine Placement 36
4.8	Operation 39
4.9	Transporting 49
4.9.1	Operating Instructions 49
4.9.2	Breaking Guidelines 50
4.9.3	Tires 51
4.10	Optional Equipment 52
5	Service and Maintenance 54
5.1	Service 54
5.1.1	Fluids and Lubricants 54
5.1.2	Greasing 54
5.1.3	Hydraulic System 55
6	Trailer Servicing Intervals 56
6.1	Servicing Record Summary (Lubrication) 67
7	Unloading System Servicing 68
7.1	Servicing Intervals 68
7.2	Service Record 74
8	Periodic Maintenance and Adjustments 75
8.1	Torque Specification Summary 75
8.2	Kingpin and Fifth Wheel Plate 77
8.3	Fifth Wheel 78
8.4	Axle Alignment 79

TABLE OF CONTENTS

SECTION PAGE	DESCRIPTION	
8.5	Wheel Hubs/Bearings	81
8.6	Wheels	85
8.7	Tires	87
8.8	Brakes	89
8.9	Slack Adjusters	92
	8.9.1 Rockwell Automatic Slack Adjuster	92
	8.9.2 Manual and Automatic Slack Adjuster Maintenance	93
8.10	Air Chamber/Spring Brake	101
8.11	Suspension System	102
	8.11.1 Air Ride Suspension	102
	8.11.2 Mechanical Suspension	106
	8.11.3 Suspension System Schematics	107
8.12	Tire Wear Patterns	108
8.13	Air System	110
	8.13.1 Air System Inspection	110
	8.13.2 Air System Functional	110
	8.13.3 Air System Schematic	111
8.14	ABS Vehicle Control System	112
8.15	ABS Schematics	114
8.16	Electrical System	115
	8.16.1 Electrical Schematics	116
8.17	Hydraulic Schematics	117
8.18	Gate Tower Manual	120
9	Boom Rotation Drive System	121
10	Trouble Shooting	122
11	Specifications	137
	11.2 Bolt Torque	138
	11.3 Hydraulic Fitting Torque	139
12	Replacement Parts HOAG Auger Trailer.....	140
13	Index.....	142

1 INTRODUCTION

Walinga appreciates your patronage and trust this unit will give you many years of trouble-free use. We are pleased to have you join a growing number of people operating Walinga Bulk Feed units.

We take pride in building products to meet the demands of discriminating buyers in the feed transporting industry. We have sought to anticipate your needs with respect to safety, convenience, design and engineering for your unit. Walinga provides information and service support to its customers through its distributor and dealer network. Contact them at once should you need assistance.

Safe, efficient and trouble free operation of your Bulk Feed unit requires that you and anyone else who will be operating or maintaining the unit, read this manual carefully and understand the Safety, Operation, Maintenance and Trouble Shooting information contained within the Operator's Manual. Failure to read and follow the manual could lead to serious injuries or costly repairs.



Trailer



Truck

Although some of the diagrams and pictures may not apply to all units, we have tried to show details of common adjustments and features that are on standard production units.

Use the Table of Contents or Index as a guide in locating the specific information applicable to your unit.

Keep this manual handy for frequent reference and to pass on to new operators or owners.

OPERATOR ORIENTATION - The directions left and right as mentioned throughout this manual, are taken as if the operator was in the driver's seat and facing in the direction of travel.

2 SAFETY

SAFETY ALERT SYMBOL

This Safety Alert symbol means **ATTENTION! BECOME ALERT! YOUR SAFETY IS INVOLVED!**

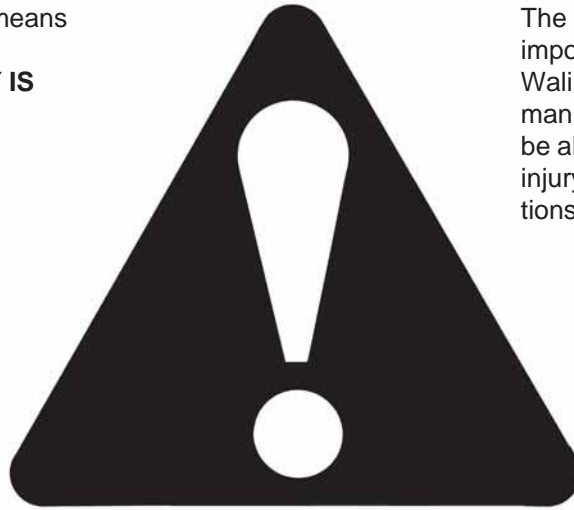

The Safety Alert symbol identifies important safety messages on the Walinga Bulk Feed unit and in the manual. When you see this symbol, be alert to the possibility of personal injury or death. Follow the instructions in the safety message.

Why is SAFETY important to you?

3 Big Reasons

**Accidents Disable and Kill
Accidents Cost
Accidents Can Be Avoided**

SIGNAL WORDS:

Note the use of the signal words **DANGER**, **WARNING** and **CAUTION** with the safety messages. The appropriate signal word for each message has been selected using the following guide-lines:

DANGER - Indicates an imminently hazardous situation that, if not avoided, will result in death or serious injury. This signal word is to be limited to the most extreme situations, typically for machine components that, for functional purposes, cannot be guarded.

WARNING - Indicates a potentially hazardous situation that, if not avoided, could result in death or serious injury, and includes hazards that are exposed when guards are removed. It may also be used to alert against unsafe practices.

CAUTION - Indicates a potentially hazardous situation that, if not avoided, may result in minor or moderate injury. It may also be used to alert against unsafe practices.

SAFETY

YOU are responsible for the **SAFE** operation and maintenance of your Walinga Bulk Feed unit. **YOU** must ensure that you and anyone else who is going to operate, maintain or work around the Truck or Trailer be familiar with the operating and maintenance procedures and related **SAFETY** information contained in this manual.

Remember, **YOU** are the key to safety. Good safety practices not only protect you but also the people around you. Make these practices a working part of your safety program. Be certain that **EVERYONE** operating this equipment is familiar with the recommended procedures and follows all the safety precautions. Remember, most accidents can be prevented. Do not risk injury or death.

- Remember the difference between being just a driver and an efficient operator. Drivers may only drive but an operator is a very safe, cost efficient and professional person.
- Bulk Feed unit owners must give operating instructions to operators or employees before allowing them to operate the equipment, and at least annually thereafter.
- The most important safety feature on this equipment is a **SAFE** operator. It is the operator's responsibility to read and understand **ALL** Safety and Operating instructions in the manual and to follow these. All accidents can be avoided.
- Walinga feels that a person who has not read, understood and been trained to follow all operating and safety instructions is not qualified to operate the equipment. An untrained operator exposes himself and bystanders to possible serious injury or death.
- Do not modify the equipment in any way. Unauthorized modification may impair the function and/or safety of the equipment and affect Truck or Trailer life.
- Think **SAFETY!** Work **SAFELY!**

2.1 GENERAL SAFETY

1. Read and understand the Operators Manual and all safety signs before operating, maintaining or adjusting the unit.



2. Only trained competent persons shall operate the unit. An untrained operator is not qualified to operate the unit.

3. Have a first-aid kit available for use should the need arise and know how to use it.



4. Do not allow riders outside the cab.

5. Have a fire extinguisher available for use should the need arise and know how to use it.



6. Wear appropriate protective gear. This list includes but is not limited to:

- A hard hat
- Protective shoes with slip resistant soles
- Heavy gloves

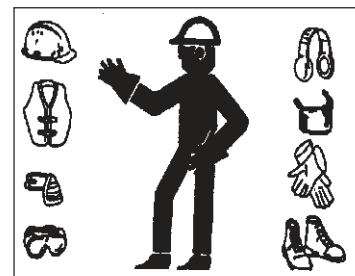

7. Place all controls in neutral, disengage PTO clutch, stop engine, set park brake, remove ignition key and wait for all moving parts to stop before servicing, adjusting or repairing.
8. Do not drink and drive.

2.2 OPERATING SAFETY

1. Read and understand all the Operator's Manual and all safety signs before operating or adjusting the Walinga Bulk Feed unit.
2. Perform circle check before driving.
3. Do not allow riders outside the cab during road or highway travel.
4. Drive very carefully when negotiating hilly or uneven terrain.
5. Keep hands, feet, clothing and hair away from all moving parts.
6. Place all controls in neutral, disengage PTO clutch, stop the engine, set park brake, remove ignition key and wait for all moving parts to stop before servicing, adjusting, repairing or maintaining.
7. Stay away from power lines when moving boom or climbing on top of the trailer. Electro-cution can occur without direct contact.
8. Do not open access doors to airlocks, trough chain or augers while the air system or auger are running.
9. Use care when climbing on ladder(s) and/or platform(s) to prevent falling.
10. Maintain running gear in good condition at all times. In addition, on trailers, maintain king pin and fifth wheel assembly in good condition.
11. Clear the area of all bystanders, especially children, before starting up and operating the unit.
12. Make sure that all lights and reflectors that are required by the local highways and transport authorities are in place, clean and can be seen clearly by all overtaking and oncoming traffic.
13. Do not operate unit with spring brakes caged or brakes disabled. Block wheels if unhooked.
14. Before disconnecting the tractor from the trailer unit(s) make sure that the tractor and trailer are on level ground and that the trailer wheels are securely blocked. Lower landing gear and provide extra support if the ground is soft. Deflate air ride if so equipped prior to uncoupling.
15. Do not unload unless vehicle is on a firm level surface.
16. Review safety items with all personnel annually.

2.3 UNLOADING SAFETY

1. Position vehicle on a firm level surface before swinging boom or unloading unit. Soft or uneven terrain can result in tipping of frame when swinging boom or unloading.
2. On semi units, position tractor and trailer in a straight line to provide maximum stability when swinging boom or unloading.
3. Stay away from power lines when swinging or raising the boom. Electro-cution can occur without direct contact.
4. Use care when on ladder or on top of unit to prevent falling. Stay away from power lines to prevent electrocution.
5. Stay out of tank compartments when unloading and when engine is running.
6. Do not operate when any guards are removed or any access doors are opened.

2.4 MAINTENANCE SAFETY

1. Read and understand all the information in the Operator's Manual regarding maintenance, adjusting and servicing the Bulk Feed unit.
2. Place all controls in neutral, disengage PTO clutch, stop the engine, remove ignition key and set the park brake before adjusting, servicing or maintaining any part of the Bulk Feed unit.
3. Follow good shop practices:

- Keep service area clean and dry.
- Be sure electrical outlets and tools are properly grounded.
- Use adequate light for the job at hand.



4. Block wheels before de-activating brakes.
5. Maintain air system and brake components in top condition at all times.
6. Maintain fasteners in running gear systems at their specified torque at all times.
7. Establish and maintain a Trailer Preventative Maintenance (TPM) program on your equipment. Some jurisdictions require this program and the maintenance of records on every commercial vehicle on the road for future reference.

2.5 HYDRAULIC SAFETY

1. Always place hydraulic controls in neutral before disconnecting from tractor or working on hydraulic system.
2. Make sure that all components in the hydraulic system are kept in good condition and are clean.
3. Replace any worn, cut, abraded, flattened or crimped hoses or lines.
4. Do not attempt any makeshift repairs to the hydraulic fittings or hoses by using tape, clamps or cements. The hydraulic system operates under extremely high-pressure. Such repairs will fail suddenly and create a hazardous and unsafe condition.

5. Wear proper hand and eye protection when searching for a high-pressure hydraulic leak. Use a piece of wood or cardboard as a backstop instead of hands to isolate and identify a leak.

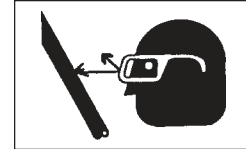

6. If injured by a concentrated high-pressure stream of hydraulic fluid, seek medical attention immediately. Serious infection or toxic reaction can develop from hydraulic fluid piercing the skin surface.

2.6 TRAVEL SAFETY

1. Read and understand all the information in the operator's manual regarding procedures and safety when operating the Bulk Feed unit on the road.
2. Make sure all the lights and reflectors that are required by the local highway and transport authorities are in place, are clean and can be seen clearly by all overtaking and oncoming traffic.
3. Drive carefully and defensively at all times and especially when negotiating uneven or hilly terrain.
4. Do not allow riders outside the cab during road and highway travel.
5. Make sure you are in compliance with all local regulations regarding transporting on public roads and highways. Consult your local law enforcement agency for further details.

2.7 TIRE SAFETY

1. Failure to follow proper procedures when mounting a tire on a wheel or rim can produce an explosion which may result in serious injury or death.
2. Do not attempt to mount a tire unless you have the proper equipment and experience to do the job.
3. Have a qualified tire dealer or repair service perform required tire maintenance.

2.8 SAFETY SIGNS

1. Keep safety signs clean and legible at all times.
2. Replace safety signs that are missing or have become illegible.
3. Replaced parts that displayed a safety sign should also display the current sign.
4. Safety signs are available from your Distributor or the factory.

How to Install Safety Signs:

- Be sure that the installation area is clean and dry.
- Be sure temperature is above 50°F (10°C).
- Decide on the exact position before you remove the backing paper.
- Remove the smallest portion of the split backing paper.
- Align the sign over the specified area and carefully press the small portion with the exposed sticky backing in place.
- Slowly peel back the remaining paper and carefully smooth the remaining portion of the sign in place.
- Small air pockets can be pierced with a pin and smoothed out using the piece of sign backing paper.

3 SAFETY SIGN LOCATIONS

The types of safety signs and locations on the equipment are shown in the illustration below. Good safety requires that you familiarize yourself with the various safety signs, the type of warning and the area, or particular function related to that area, that requires your SAFETY AWARENESS.

- Think SAFETY! Work SAFELY!



A

 **CAUTION**

1. Read Operator's Manual and safety signs before operating.
2. Do not load trailer in excess of the gross vehicle weight rating shown on the certification plate.
3. Do not allow riders on the trailer.
4. Keep hands, feet, clothing and hair away from all moving parts.
5. Place all controls in neutral, stop the engine, set park brake, remove ignition key and wait for all moving parts to stop before servicing, adjusting, repairing or maintaining.
6. Maintain king pin, fifth wheel assembly and all running gear components in good condition at all times.
7. Make sure that all lights and reflectors are clean and working when transporting on public roads.
8. Keep all hydraulic lines, fittings and hoses tight, free of leaks and in good condition at all times.
9. Do not operate unit with spring brakes caged or brakes disabled. Block wheels if unhooked.
10. Stay away from overhead power lines when moving boom to prevent electrocution.
11. Raise boom only when trailer is on firm, level ground and evenly loaded.
12. Do not unhook trailer if it is loaded.
13. Do not load trailer unless it is attached to a towing unit.
14. Review safety items with all personnel annually.

53-17706-6

B

 **DANGER**



**ROTATING AUGER HAZARD
KEEP AWAY**

To prevent serious injury or death from rotating auger:

1. Place all controls in neutral, stop engine, set park brake, remove ignition key and wait for all moving parts to stop before servicing, repairing, adjusting or unplugging.
2. Do not operate with the auger guards removed.
3. Do not stand near augers when operating. Keep others away.

53-17705-6

REMEMBER - If safety signs have been damaged, removed, become illegible or parts replaced without signs, new signs must be applied. New signs are available from your authorized dealer or factory direct.

OPERATING INSTRUCTIONS

HYDRAULIC CONTROLS FOR HOAG UNIT

The operator must remain at the controls while unit is in operation.

Do not operate the Hydraulic Controls, until you have read this label and understand how to safely operate this hydraulic control.

Remember, Safety First! Always look for overhead wires before positioning the boom.

Leave the air in the suspension when moving the boom and unloading.

Never drive or move the unit with the boom out of the saddle.

Caution: Do not open more than one bin at a time.

There are 4 Hydraulic Pressure Gauges that all register separate pressures:

(Top To Bottom)

- 1) Boom Pressure
- 2) Boom Rotation Pressure
- 3) Vertical Pressure
- 4) Trough Pressure

Maximum operating pressure for discharge gauges is 2500 PSI.

These 4 gauges indicate pressure by the amount of product being fed into the Augers from the Trough Auger.

1. Position the Boom with the engine at idle speed. Engine operating RPM is listed in the cab.
2. Once the boom is in the proper position over the bin, and the engine RPM is set, turn the Manual Flow Adjuster so that it is turned in all the way to the right (clock-wise).

Then turn the Adjuster out (counter-clockwise) 2-3 turns. Use this as a starting point, first start the Boom and Vertical Augers. Start the Trough Auger last, while monitoring the gauge pressures. Now open compartments one at a time. At each delivery, adjust the trough speed with the Manual Flow Adjuster to suit the feed type, as well as the boom height.

3. The Manual Flow Adjuster controls the amount of product fed by the trough auger into the boom & vertical Unloading/Auger systems. To maximize performance, the boom will speed up or slow down while changing the speed of the trough auger with the Manual Flow Adjuster. Note: Do not over adjust trough control to cause boom to slow down and labor hard. Always listen for this when adjusting trough auger.
4. In the event the bin has been overfilled and feed has backed into the sock, immediately shut the augers off. Raise the boom until the sock empties, then start the Boom Auger briefly to empty out the boom. Lower the boom into the transport cradle. Disengage PTO before driving.

The types of safety signs and locations on the equipment are shown in the illustration below. Good safety requires that you familiarize yourself with the various safety signs, the type of warning and the area, or particular function related to that area, that requires your SAFETY AWARENESS.

- Think SAFETY! Work SAFELY!

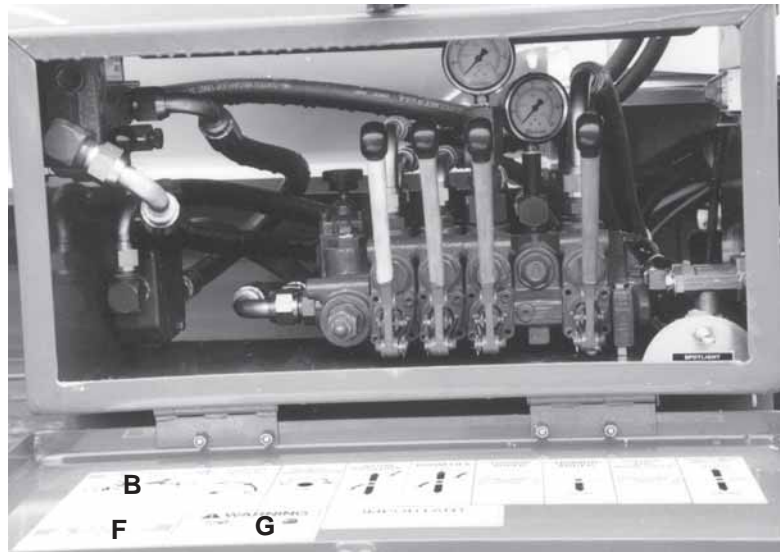

REMEMBER - If safety signs have been damaged, removed, become illegible or parts replaced without signs, new signs must be applied. New signs are available from your authorized dealer or factory direct.

The types of safety signs and locations on the equipment are shown in the illustration below. Good safety requires that you familiarize yourself with the various safety signs, the type of warning and the area, or particular function related to that area, that requires your SAFETY AWARENESS.

- Think SAFETY! Work SAFELY!

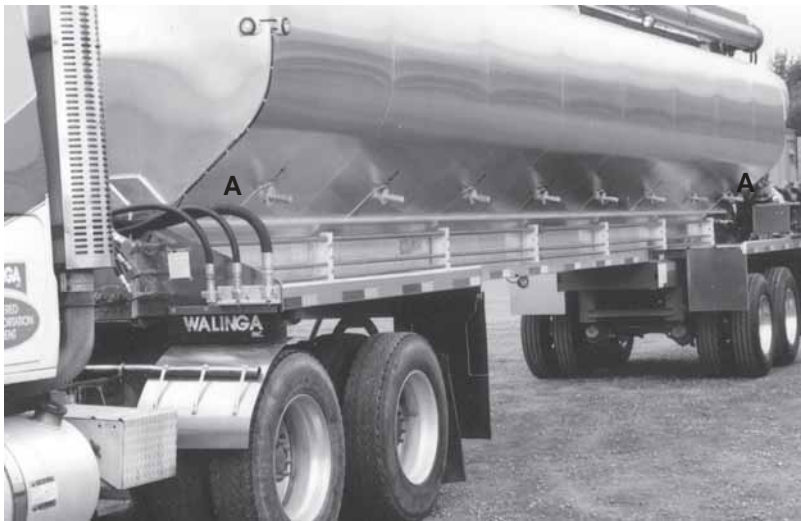

D

WARNING

**ROTATING PART HAZARD
KEEP AWAY**

To prevent serious injury or death from rotating parts:

1. Place all controls in neutral, stop engine, set park brake, remove ignition key and wait for all moving parts to stop before servicing, repairing, adjusting or unplugging.
2. Close and secure guards before operating.
3. Keep hands, feet, hair, and clothing away from moving parts.

53-17703-6

E

WARNING

FALLING HAZARD

To prevent serious injury or death from falling:

1. Use care when climbing ladder or working on platform.
2. Keep unauthorized people off machine.
3. Do not allow riders.

53-17702-6

REMEMBER - If safety signs have been damaged, removed, become illegible or parts replaced without signs, new signs must be applied. New signs are available from your authorized dealer or factory direct.

The types of safety signs and locations on the equipment are shown in the illustration below. Good safety requires that you familiarize yourself with the various safety signs, the type of warning and the area, or particular function related to that area, that requires your SAFETY AWARENESS.

- Think SAFETY! Work SAFELY!



F

DANGER
ELECTROCUTION HAZARD
 To prevent serious injury or death from electrocution:

- Stay away from power lines when transporting and raising or lowering boom.
- Electrocution can occur without contacting power lines.

53-17701-6

REMEMBER - If safety signs have been damaged, removed, become illegible or parts replaced without signs, new signs must be applied. New signs are available from your authorized dealer or factory direct.

The types of safety signs and locations on the equipment are shown in the illustration below. Good safety requires that you familiarize yourself with the various safety signs, the type of warning and the area, or particular function related to that area, that requires your SAFETY AWARENESS.

- Think SAFETY! Work SAFELY!



G

	 <h2>WARNING</h2> <h3>HIGH-PRESSURE FLUID HAZARD</h3> <p>To prevent serious injury or death:</p> <ul style="list-style-type: none">• Relieve pressure on hydraulic system before servicing or disconnecting hoses.• Wear proper hand and eye protection when searching for leaks. Use wood or cardboard instead of hands.• Keep all components in good repair. <p>53-15638-6</p>
	

REMEMBER - If safety signs have been damaged, removed, become illegible or parts replaced without signs, new signs must be applied. New signs are available from your authorized dealer or factory direct.

4 OPERATION GUIDELINES



OPERATING SAFETY

1. Read and understand all the Operator's Manual and all safety signs before operating or adjusting the Walinga Bulk Feed unit.
2. Perform circle check before driving.
3. Do not allow riders outside the cab during road or highway travel.
4. Drive very carefully when negotiating hilly or uneven terrain.
5. Keep hands, feet, clothing and hair away from all moving parts.
6. Place all controls in neutral, disengage PTO clutch, stop the engine, set park brake, remove ignition key and wait for all moving parts to stop before servicing, adjusting, repairing or maintaining.
7. Stay away from power lines when moving boom or climbing on top of the trailer. Electrocutation can occur without direct contact.
8. Do not open access doors to airlocks, trough chain or augers while the air system or auger are running.
9. Use care when climbing on ladder(s) and/or platform(s) to prevent falling.
10. Maintain running gear in good condition at all times. In addition, on trailers, maintain king pin and fifth wheel assembly in good condition.
11. Clear the area of all bystanders, especially children, before starting up and operating the unit.
12. Make sure that all lights and reflectors that are required by the local highways and transport authorities are in place, clean and can be seen clearly by all overtaking and oncoming traffic.
13. Do not operate unit with spring brakes caged or brakes disabled. Block wheels if unhooked.
14. Before disconnecting the tractor from the trailer unit(s) make sure that the tractor and trailer are on level ground and that the trailer wheels are securely blocked. Lower landing gear and provide extra support if the ground is soft. Deflate air ride if so equipped prior to uncoupling.
15. Do not unload unless vehicle is on a firm level surface.
16. Review safety items with all personnel annually.

4.1 TO THE NEW OPERATOR OR OWNER

The Walinga Bulk Feed units combine light weight construction methods combined with high strength materials to become a safe, reliable and efficient feed or grain hauling unit. Be sure to familiarize yourself with the unit by reading this Operator's Manual, the Safety Alerts and any other material provided with the unit before attempting to operate it. With careful use and a good maintenance schedule, the unit will give many years of trouble-free use.

It is the responsibility of the owner and operator to be familiar with the weight and loading of your trailer. Trailer weight and loading requirements vary from jurisdiction to jurisdiction. Be familiar with yours and any that you will be travelling through.

4.2 TERMINOLOGY

The Walinga Bulk Feed unit is available as a semi-trailer or a straight frame truck. High strength aluminium is used for the tank and structural components to minimize weight and maximize payload.

Augers are used at the bottom of the tank, in the vertical tube and boom to unload. All augers and paddle chain are powered by a hydraulic motor to provide maximum unloading efficiency. The boom rotates and raises to allow unloading into a variety of customer feed storage facilities.

Sliding gates control the flow of material to the tank unloading auger. The controls for all systems are located in the box on the left rear corner. Each truck or tractor section must be equipped with a hydraulic power pack to provide oil flow to the hydraulic motors and cylinders.



Fig. 4-1 PRINCIPAL SYSTEMS

4.3 BREAK-IN

Break-in is the most important time in a Truck or a Trailer's life. It is critical that the unit be checked frequently during the first 5000 miles to be sure that all components and systems are properly adjusted and performing as required.

The following inspection schedule is provided as a guide for normal operating conditions. More frequent inspections are recommended in severe or extreme conditions.

Inspect at:

50-100 miles, 1-2 hours

500 miles, 8-10 hours

1500 miles, 25-30 hours

5000 miles, 100 hours:

1. Brakes

It takes a few weeks of operation for the brake shoes to mate with the drum contour and burnish the surface. During this period of time, the operator should check the brakes every day. After the first month, inspection of the brakes every 2 weeks or every 10,000 miles is required. Check the function and adjustment of the brakes on each axle. All brakes should apply evenly. No shoes should drag on the drum when the brakes are not applied.

2. Tires

Tires are designed to provide maximum life and performance when maintained at their specified inflation pressure. Although the tires are inflated to their specified pressure at the factory, the pressure can change before going into service. Always use an accurate gauge to check the pressure when the tire is cold.

3. Wheels/Rims

Although lug bolts and rim fasteners are always tightened to their specified torque at the factory, it is normal for them to lose some of their torque during the first few miles of operation. Always retorque lug bolts and rim fasteners to be sure that they stay tight. Then go to the retorquing interval defined in the Maintenance section of every 25,000 miles. Keep all fasteners tightened to their specified torque to prevent damaging any components.

Whenever a wheel is removed from an axle, the above retorquing procedure must be followed to be sure that the wheel is secured to the axle. If any component is damaged due to loose fasteners, it will have to be replaced.

4. Axles

Each wheel bearing is assembled at the factory with the required end play (refer to Section 8.5). This end play should be checked to insure proper axle and bearing function. Check the temperature of the hub by hand after 10 to 15 miles (15 to 25 km) during the first trip. A hot hub must have the bearing end play reset before continuing.

Jack the axle up and support it on a stand. Turn the wheel by hand. The wheel should turn freely. If it does not, check if the brakes are dragging or if the bearing has too much end play. If either of these conditions exist, correct before proceeding.

Move the wheel laterally on the axle shaft. If the wheel wobbles, the bearing has lost its end play. Tighten bearing and set end play before continuing.

5. Hub Lubricant Levels

a. Oil Bath:

Oil bath hubs are used on some trailers and are filled at the factory. Check hubs frequently (at least daily) during the first few weeks of operation. Always check when the oil is cold and the trailer is on the level. Use the level mark on the hub face when checking oil level. Replace seals and gaskets if hub has an oil leak. Do not operate without oil in the hub.

b. Grease Packed:

Grease packed hubs are used on some trailers and do not require servicing unless the wheel end is being serviced or removed.

4.3 BREAK-IN (cont'd)

6. Suspension

A suspension system connects the axles to the frame. All fasteners must be maintained at their specified torque to ensure that all clamping and anchoring forces remain intact. If these forces are not maintained, components can shift or move and affect the performance and component life. Refer to Maintenance Section for the list of required torque values for all fasteners in suspension system. Any loosening can lead to component shifting, misalignment and/or twisting. Any of these items can cause erratic handling, broken components or rapid tire wear. Always tighten the nut end of fastener. Specified torque values apply only to nut end torquing.

7. Axle Alignment

Axle alignment is properly set at the factory when the unit is new and will remain aligned unless fasteners loosen or components wear. Use a steel measuring tape to check the alignment. Refer to Maintenance Section for alignment checking procedure. Axles that are out of alignment can cause erratic handling characteristics, broken components and accelerated tire wear.

8. Fifth Wheel Assembly Components

The king pin, anchor frame and upper and lower fifth wheel assemblies must be inspected to check for mechanical integrity of all components. All components and systems must be kept in good condition to safely and reliably transmit the accelerating, braking and side loads between the trailer, fifth wheel and towing vehicle.

a. King Pin:

Check the king pin for cracks, chips, or whether it is bent. Check that there are no cracks or distortions between the king pin and its anchor frame. If any defects are found, replace the king pin and its anchor frame before resuming work.

b. Fifth Wheel Assembly:

The fifth wheel assembly consists of the king pin locking mechanism, surface plate, frame, pivot and anchor system. Check that the king pin locking mechanism locks and unlocks easily and that all moving surfaces are coated with grease. Check that the surface plate is free of grit and coated with grease.

Check the surface plate and anchor frame for cracks, bends or distortions. Replace any damaged components. Retorque fasteners to maintain the proper clamping forces on all components. Loose fasteners can cause components to move or bend and create mechanical or safety problems during operation.

9. Electrical, Hydraulic and Air Lines

Electrical, hydraulic and air lines extend from the front of the unit to each electrical, hydraulic and air operated component. Although they are all anchored along their routing pathways from the factory, they occasionally do come loose and will sag. Inspect all lines. Use plastic ties to secure line to frame if any are loose and sag. Replace if any are pinched, kinked, cut or abraded. Extra care should be taken in cold or extreme operating conditions. Ice, mud or brush can pull lines loose from their anchors and cause damage. Clean components, repair damage, re-anchor and install protectors if appropriate. Do not operate with damaged components.

4.4 PRE-OPERATION VEHICLE INSPECTION PROCEDURE - FOR TRAILERS

The safe and trouble-free use of a Walinga Bulk Feed Unit requires the operator to maintain the unit in good operating condition. To assist the operator, a pre-operation checklist is provided that should be followed each time before the unit is used.

NOTE

The tractor items, part of the Department of Transport (D.O.T.) walk around sequence, have been omitted.

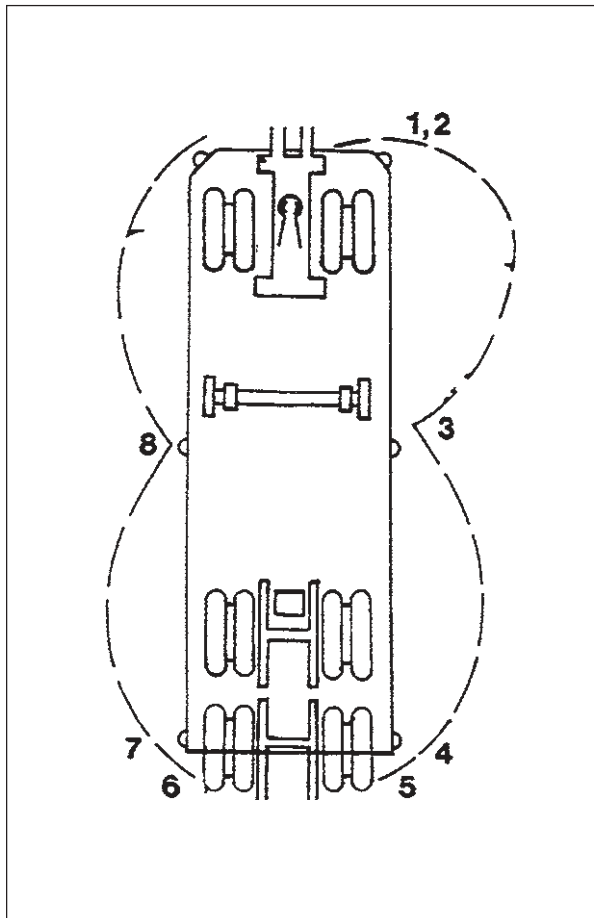

Fig. 4-2 WALKAROUND SEQUENCE

WALK AROUND SEQUENCE

Step 1 - Trailer Frontal Area

1. **Air, Hydraulic and Electrical Connections**
 - a. Glad hands properly mounted, free of damage, not leaking and not worn.
 - b. Electrical line receptacle properly mounted, free of damage, plug adequately seated and safety catch engaged to prevent accidental disconnection.
 - c. Hydraulic couplers properly seated and tightened, no leaks and properly secured against tangling, snagging and chafing, with sufficient slack for turning.
 - d. Air, electrical and hydraulic lines properly secured against tangling, snagging and chafing with sufficient slack for turns.
2. **Lights and Reflectors**
 - a. Front trailer clearance and identification lights - should be clean, operating and proper color.
 - b. Reflectors and conspicuity tape clean and proper color.

Step 2 - Coupling System Area

1. **Fifth Wheel (Lower)**
 - a. Securely mounted to frame.
 - b. No missing or damaged parts.
 - c. No visible space between upper and lower fifth wheel.
 - d. Locking jaws around the shank and not the head of kingpin.
 - e. Release lever properly seated and safety latch lock engaged.
2. **Fifth Wheel (Upper)**
 - a. Kingpin not worn, bent or damaged.
 - b. Anchor frame not cracked, bent, worn or damaged.
3. **Air, Hydraulic and Electric Lines Visible From This Point**
 - a. Should be secure from dangling, snagging and chafing.
 - b. Should be free from damage and clean.

4.4 PRE-OPERATION VEHICLE INSPECTION PROCEDURE - FOR TRAILERS (cont'd)

Step 3 - Right Side of Trailer Area

1. **Front Trailer Support (Landing Gear)**
 - a. Fully raised, no missing parts, not bent or otherwise damaged.
 - b. Crank handle secured.
2. **Spare Tires**
 - a. Carrier or rack not damaged.
 - b. Tire and/or wheel securely mounted in the rack.
 - c. Tire and wheel condition adequate. Proper spare tire size, correctly inflated.
3. **Lights and Reflectors**
 - a. Trailer side clearance lights clean, operating and proper color.
 - b. Reflectors and conspicuity tape clean and proper color.
4. **Frame and Body**
 - a. Frame and cross members not bent, cracked, damaged or missing.
 - b. Body parts not damaged or missing.
5. **Air Tank**
 - a. Drain moisture from air tank(s). Pull on cable attached to drain valve. Hold cable until the tank moisture is drained.

NOTE

In cold weather, it is best to drain the moisture from the tanks at the end of the day to prevent ice build-up in the tanks.

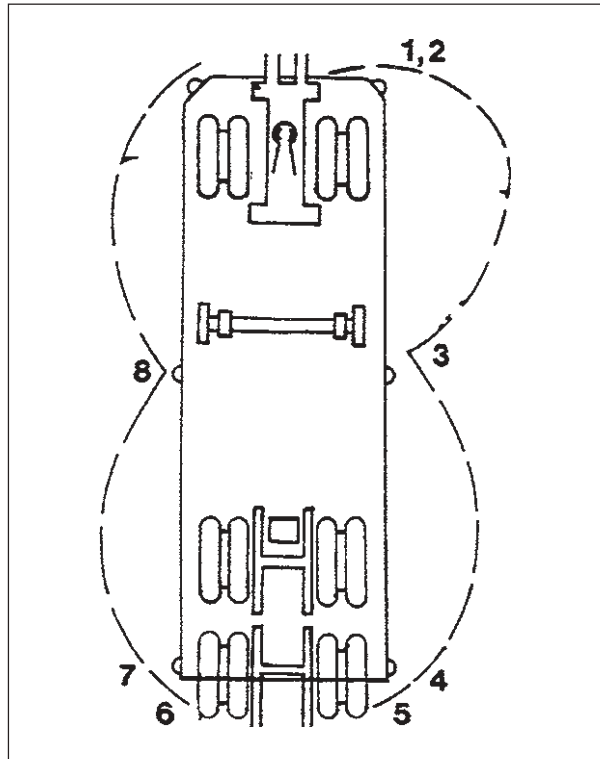

Fig. 4-3 WALKAROUND SEQUENCE

Step 4 - Right Rear Trailer Wheel Area

1. **Dual Wheels**
 - a. Condition of wheels and rims, no cracked or bent rims, broken spacers, studs, clamps or lugs.
 - b. Condition of tires - properly inflated, valve stems not touching wheel rims or brake drums, valve caps in place, no serious cuts, bulges, tread wear or any signs of misalignment and no debris stuck between the tires.
 - c. Tires all same type e.g. do not mix radial and bias types on the same axles.
 - d. Wheel bearings and hub - no obvious leaking.
 - e. Mud flaps in place and in good condition.
2. **Tandem or Triaxles**
 - a. Repeat wheel and tire inspection as above.
 - b. Flexible air lines not cracked, cut, crimped or otherwise damaged, secured against tangling, dragging or chafing.
 - c. Sliding axle anchor pins locked in place.
3. **Suspension**
 - a. **Mechanical:**
Condition of spring(s), spring hangers, equalizers and U-bolts.
 - b. **Air:**
Condition of air bag(s), axle clamping bolts, pivot arm and height control valve.
 - c. Check that air suspension is inflated and at proper ride height.

Step 5 - Brakes

1. **Brakes**
 - a. Condition of brake drum(s).
 - b. Condition of hoses, lines and valves.
 - c. Check slack adjusters.
 - d. Check air chamber mounting.
 - e. Check spring brakes (if so equipped).
 - f. Drain moisture from air tank with cable.

Step 6 - Rear of Trailer

1. **Lights and Reflectors**
 - a. Rear clearance and identification lights, clean and operating and proper color.
 - b. Reflectors and conspicuity tape clean and proper color.
 - c. Tail-lights clean, operating and proper color.

2. Check Unloading Systems

Check that access doors are closed and secured, compartment gate crank is stowed and secured, the boom is in its transport cradle, tank covers are closed, control box door closed and secured, and all guards in place and secured.

Step 7 - Left Rear Trailer Wheel Area

Check all items as done on right side (Step 4 "Right Rear Trailer Wheel Area").

Step 8 - Left Side of Trailer Area

1. Check all items as done on right side (Step 3 "Right Side of Trailer Area").
2. **Tank Gate System**
 - a. Check that tank slide gates are down and secured with retainer.
 - b. Check that tank gate crank is stowed and secured.

Step 9 - Trailer Functional Check (Tractor Attached)

1. Check for proper connection of the air brake glad-hands, hydraulic system couplers and secure contact of electrical connection.
2. Start engine.
3. Build up air pressure in the tractor-trailer systems.
4. Turn on lights and inspect for proper function of:
 - a. Clearance lights.
 - b. Identification lights.
 - c. Turn signals and 4-way flasher.
 - d. Sidemarkers lights.
 - e. Tail lights.
 - f. Stop lights.
5. Check the function of brakes.
 - a. Apply service brakes.
 - b. Apply parking/emergency brakes.
 - c. Stop engine.
 - i. Release trailer emergency brakes.
 - ii. Apply service brakes
Air loss should not exceed
3 psi per minute on single vehicles.
4 psi per minute on combination.

4.5 HOOKING UP/UNHOOKING TRAILER

Special care should be taken when hooking up or unhooking trailer to be sure the equipment is in good condition and all systems are functioning as required.

4.5.1 HOOKING UP

Follow this procedure when hooking up the trailer to tractor:

1. Back the tractor up in a straight line to the trailer and align the fifth wheel opening with the trailer king pin.
2. Stop before the fifth wheel makes contact with the trailer and apply the towing vehicle parking brake.
3. Inspect all the coupling components before hooking up:
 - a. Inspect trailer coupling components. Check that king pin is not broken, bent or chipped. Check that the anchor frame is not distorted or cracked. If problems found, correct before proceeding.
 - b. Inspect fifth wheel coupling components. Check that the fifth wheel assembly is securely anchored to the tractor frame. Check that the structure of the frame, pivot and fifth wheel is not bent, broken or cracked. Check that the jaws of the lock are open. If problems found, correct before proceeding.
 - c. Be sure that the fifth wheel plate is cleaned and greased.
4. Check that the trailer is at the required height to slide onto the fifth wheel.
 - a. Use the crank on the landing gear to raise or lower the trailer as required.

The trailer frame should contact the fifth wheel just behind the pivot point as the tractor backs under the trailer.

5. Connect brake and electrical lines. Route the lines so they do not get pinched.

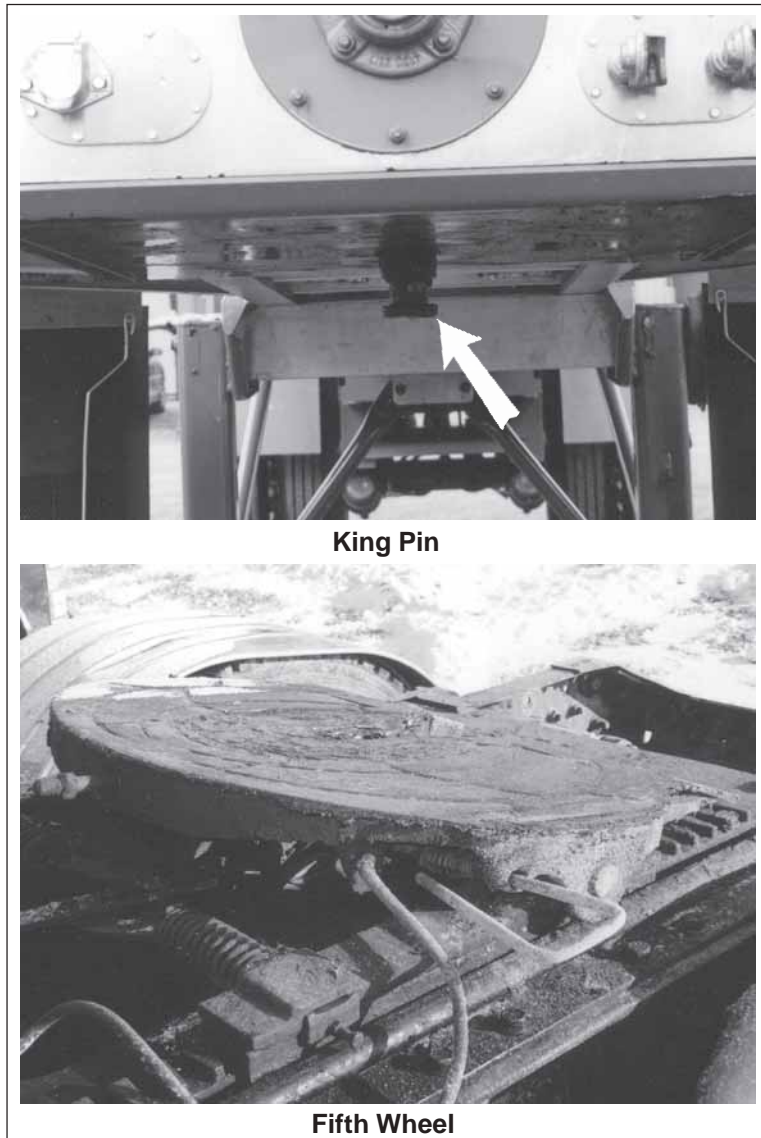

Fig. 4-4 COUPLING COMPONENTS

6. Back slowly under trailer keeping the king pin centered in the fifth wheel jaws.
7. Back up until the fifth wheel coupler locks on the trailer king pin.
8. Move the towing vehicle forward sharply while the trailer brakes are engaged to check that the jaws have locked around the king pin.
9. Set tractor parking brake, stop engine and dismount.
10. Visually check that the coupler jaws are securely locked around the king pin and the coupler release lever is in the locked position. Release and hook up again if the jaws are not securely locked around the king pin.
11. Check that the trailer frame is resting on the fifth wheel.
12. Check brake application by applying and releasing brakes. If brakes do not release, air lines may be crossed. Do not continue unless brakes are functioning properly.
13. Connect and secure the pressure and return hydraulic lines. Start hydraulic pump and check that there are no leaks.
14. Check that all electrical circuits are completed and that all lights are working.
15. Route the electrical, hydraulic and air lines to prevent snagging, dragging and pinching.
16. Raise the landing gear. Use the crank to raise the legs. Place drive gear in low ratio and stow crank.
17. Check that the air ride bags are inflated to proper height.
18. Remove blocks or chocks from the wheels.
19. Perform Pre-Operation Inspection before starting.

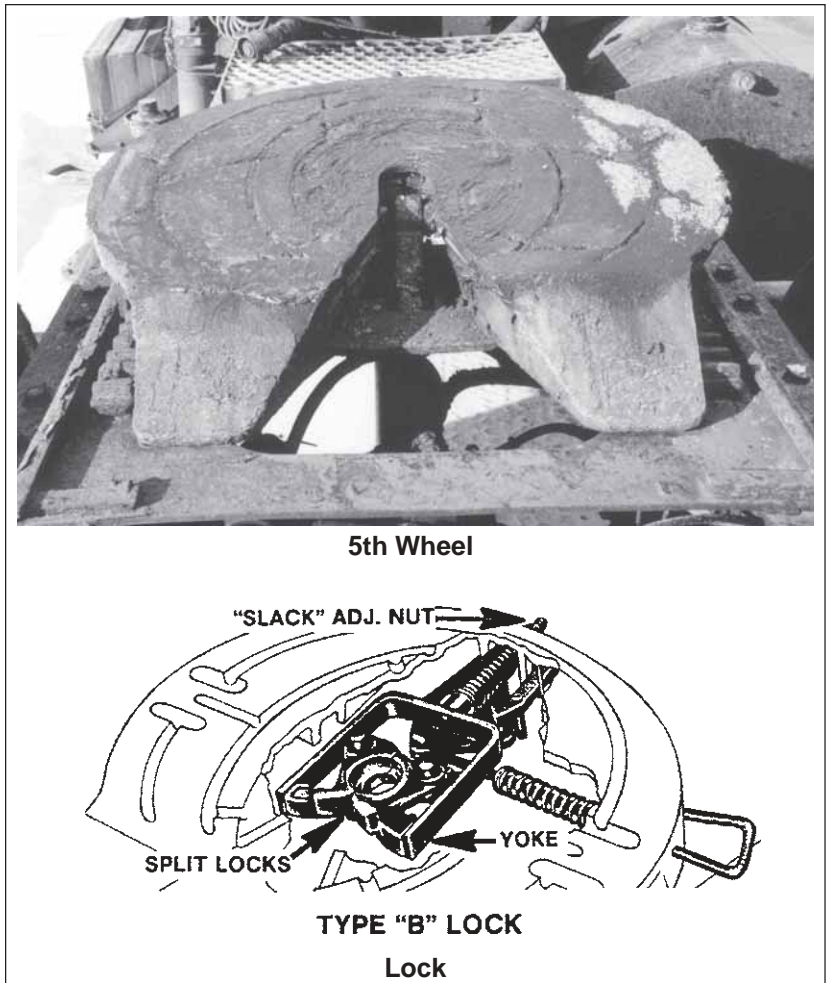

Fig. 4-5 COUPLER LOCKS

4.5.2 UNHOOKING TRAILER

1. Position tractor and trailer in a straight line on a clear, level and firm surface.
2. Apply the trailer brakes and the parking brakes on the tractor before dismounting.
3. Place blocks or chocks in front of and behind trailer wheels if not on a level surface.
4. Check that the surface under the landing pads can support the trailer. Support with blocks or planks if required. This is particularly important if the trailer is loaded or will be loaded while unhooked.



Fig. 4-6 LANDING GEAR

5. Deflate air suspension system.
6. Lower landing gear. Use crank to lower leg on landing gear. Lower leg until pads solidly contact the ground but do not lift trailer off fifth wheel. Stow crank.
7. Unhook fifth wheel coupler.
8. Disconnect air and hydraulic lines and electrical connector.
9. Release tractor parking brake and pull slowly forward until the trailer frame just slides down the fifth wheel ramp. Stop.
10. Set the parking brake on the tractor before dismounting.



Fig. 4-7 UNHOOKED

11. Disconnect air and hydraulic lines and electrical connector.
12. Install glad hands on dead end connectors if so equipped.
13. Drive tractor away from trailer.
14. Drain air tanks if operating in cold temperatures to eliminate ice build-up.
15. Inspect the equipment. Document problems found so they can be corrected before the unit will be used the next time. Record problems and repairs for your files.

4.6 CONTROLS

Before starting to work, all operators should familiarize themselves with the location and function of all controls. Each unit is controlled by the main control box and the electric switch box located at the left rear corner of the unit.

1. Control Box

a. Flow Divider:

The flow divider sets the amount of oil flowing to the trough auger. Turn counter-clockwise 2 turns to start, then turn clock-wise to increase speed. Maintain pressure between 1500 and 2600 psi (10342 and 17926 kPa) on the trough auger pressure gauge. Use the manual control to obtain this pressure range.

b. Air Dump Valve:

This 2 position valve is located in the dump line for the air suspension air system. Move the handle clockwise to close the dump line. The valve must be in this position to re-inflate the air suspension. Move the handle counter-clockwise to dump the air from the suspension.

c. Boom Lift Switch:

This spring-loaded-to-neutral-centre electric switch controls the position of the boom height. Push the switch up and hold the switch to raise the boom. Release the switch and it will return to its centred neutral position to stop the boom lift. Push the switch down and hold to lower the boom. Release the switch to stop its motion.

d. Boom Rotation Switch:

This spring-loaded-to-neutral-centre switch controls the direction of the boom rotation. Push the switch right and hold the switch to swing the boom to the right (clockwise) Release the switch and it will return to its centred

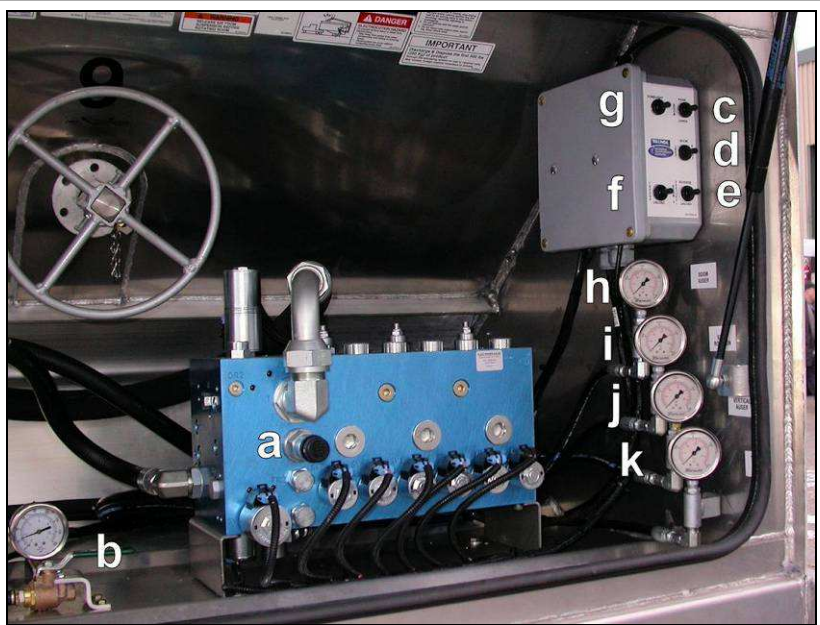

Fig. 4-8 CONTROL BOX



Fig. 4-9 CONTROL BOX LOCATION

Neutral position to stop the boom rotation. Push the switch left and hold to swing the boom to the left (counter-clockwise).

e. Vertical and Boom Auger Switch:

This 3 position hydraulic valve controls the flow and direction of flow to the vertical and boom auger drive systems. Push the switch down to run the augers for unloading. Place the switch in its centred position to stop the augers. Push the switch up to run the augers in their reverse direction. It is recommended that the boom and vertical augers be run only momentarily in the reverse direction as this position is provided to assist in unplugging either auger as required.

f. Trough Auger Switch:

This 2 position hydraulic valve controls the flow of oil to the trough auger drive motor. Push the switch down to direct the flow of oil to the motor and run the trough auger. Push the switch back up to stop the flow of oil and stop the trough auger.

An optional 3 position switch is available where pushing the switch up will reverse the auger and is useful to assist in unplugging.

g. Dome Light Switch:

This toggle switch controls the power to the working lights on the back of the machine. Move the switch up to turn the lights ON and down for OFF.

Pressure Guages : Trough Auger, Vertical Auger, Boom Rotation and Boom Auger.

Normally this system can operate between 1500 to 2600 psi (10342 to 17296 kPa) Set the manual flow adjuster for the trough auger to operate the boom auger drive system in this range. Turn counter-clockwise 2 turns to start, then turn clock-wise to increase speed. The amount of material fed by the floor auger controls the pressure in the boom and vertical auger drive system.

h. Boom Auger Pressure Gauge

This pressure gauge shows the pressure in the boom auger drive .

i. Boom Rotation Pressure Gauge

This pressure gauge shows the pressure in the boom rotation .

j. Vertical Auger Pressure Gauge:

This pressure gauge shows the pressure in the vertical auger drive.

k .Trough Auger Pressure Gauge:

This pressure gauge monitors and shows the pressure in the trough conveyor drive system.

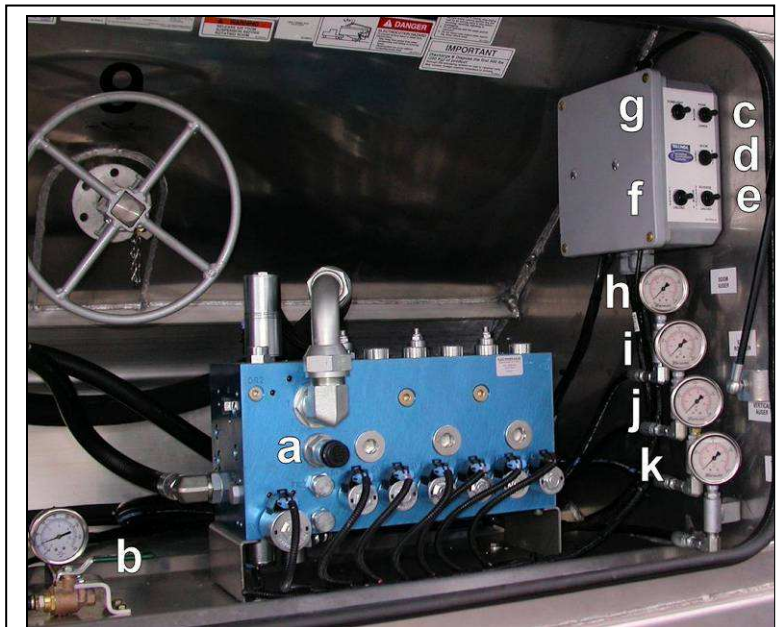

Fig. 4-10a CONTROL BOX

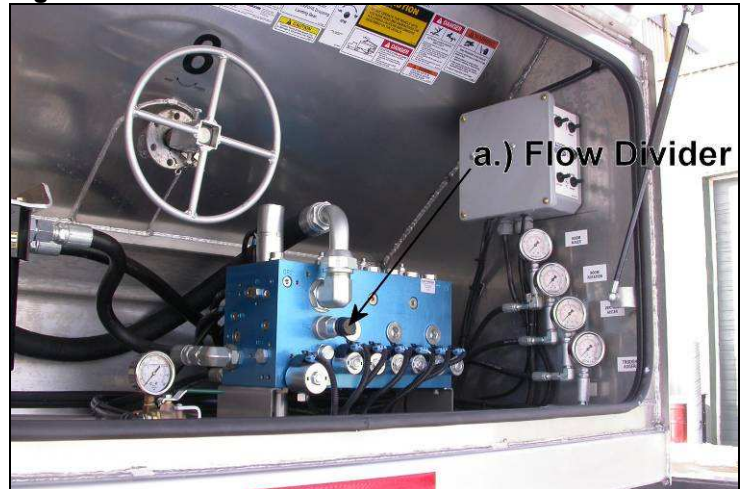

Fig. 4-10b FLOW DIVIDER CONTROL

2. Control Box for Covers

a. Roof Cover Position (Front):

This 2 position toggle switch controls the flow of air and direction of air to the cylinders that set the position of the cover over the front tank. Move switch to its fully up position to close the front tank cover. Move the switch completely down to open the cover over the front tanks.

b. Roof Cover Position (Rear):

This 2 position toggle switch controls the flow of air and direction of air to the cylinders that set the position of the cover over the rear tank. Move switch to its fully up position to close the rear tank cover. Move the switch completely down to open the cover over the rear tanks.

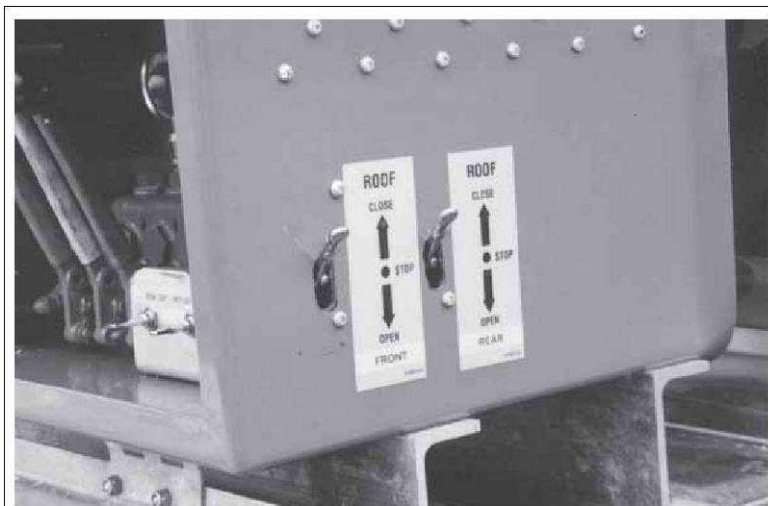

Trailer



Truck

Fig. 4-11 CONTROL BOX

4.6 CONTROLS (cont'd)

3. Tank Gate Position:

A. Manual

This square shaft controls the position of the gates over the trough conveyor in the bottom of each tank section. Use the crank provided with each unit to turn the shaft clockwise to open the gates and counter-clockwise to close. Always close the gate(s) before loading the tank(s).

- a. Open
- b. Close



WARNING

Machine is shown with guard removed or access door opened for illustrative purposes only. Do not operate machine with guard removed or access door opened.

B. Air

This two position toggle switch controls the power to the valve that directs the air to the cylinder inside the gate tower. Move the switch up to open the gate and down to close.

Open

Close

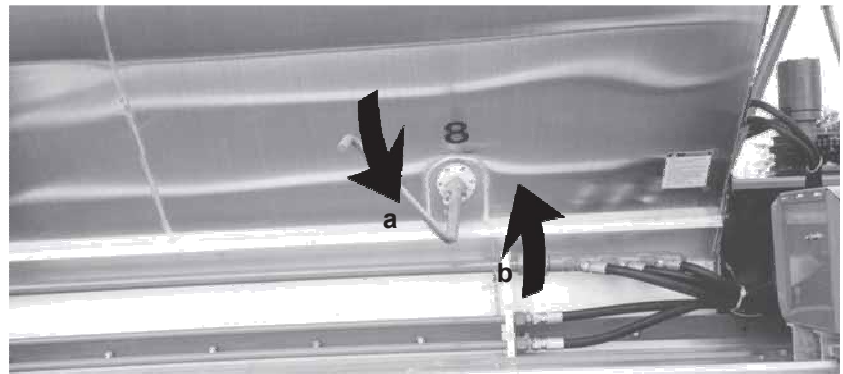

Crank - Manual

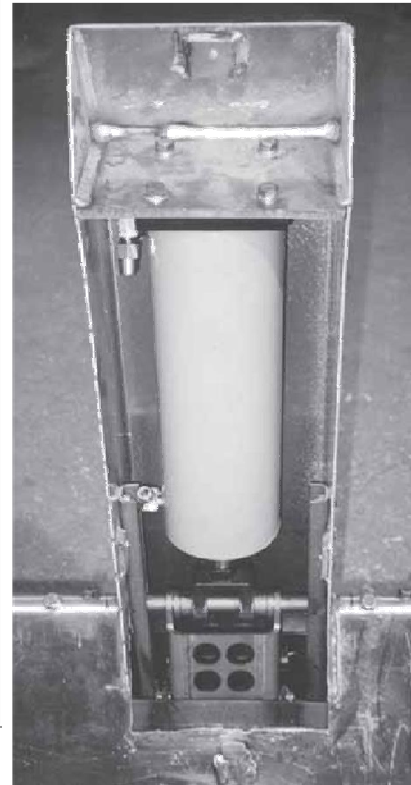
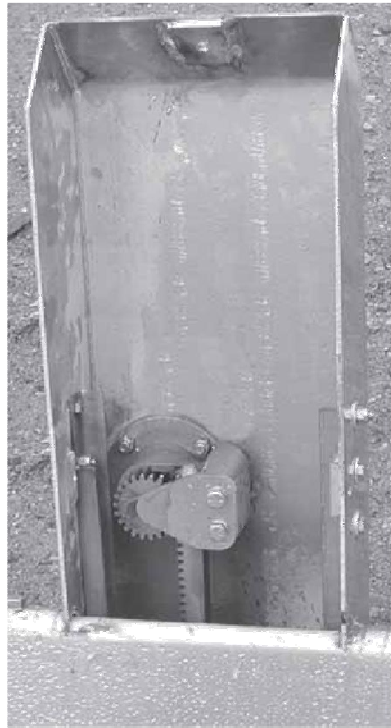

Manual

Air

Tower Opened



Switch - Air

Fig. 4-12 TANK GATE

4. Cab Controls:

Each tractor section or power unit must be equipped with an auxiliary hydraulic system to provide pressurized oil to operate the machine. The hydraulic pump is powered through the PTO drive with the control box located in the doorway to the left of the driver. The control for the pump PTO will be labelled.

Pull the yellow collar up and move the red knob forward to engage the PTO and drive the hydraulic pump. Push down to disconnect the drive and stop the pump. Most systems are not "live" and cannot be engaged and disengaged without depressing the clutch.



Fig.13 PTO CONTROLS

NOTE

Put truck in gear first to stop transmission clash when engaging PTO. Then shift transmission to neutral again when PTO engaged.

5. Remote Control (Optional):

a. ON/OFF Switch:

This 2 position toggle switch turns the power on to the hand held radio transmitter. Move the switch to the left (toward the aerial) to turn OFF and to the right to turn ON.

b. Emergency Stop:

This red button switch is the emergency STOP control for the controller functions. Depress the button switch to stop all boom motion (lift and rotation). Turn the power switch OFF and then ON to re-activate the control box prior to using the controller again.

c. Boom Rotation:

This 3 position spring-loaded-to-centre neutral switch controls the boom rotation function. Move the switch to the left and hold to move the boom out (counter-clockwise). Release the switch and it will return to its centred neutral (OFF) position to stop the boom rotation. Move the switch to the right and hold to swing the boom in (clockwise). Release the switch to stop the motion.

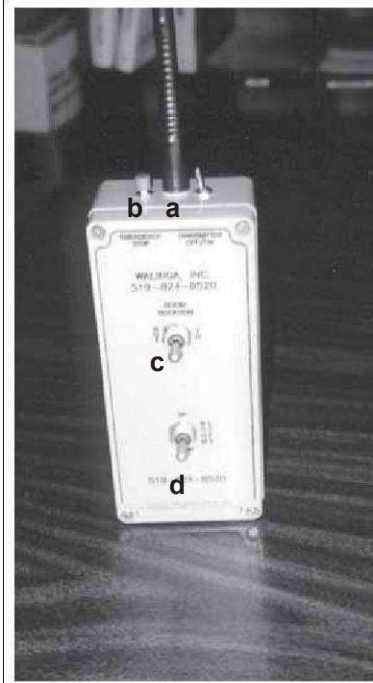

Transmitter

Receiver

Fig. 4-14 REMOTE CONTROL (OPTIONAL)

d. Boom Lift:

This 3 position spring-loaded-to-centre neutral switch controls the boom lift function. Move the switch up and hold to raise the boom. Release the switch and it will return to its centred neutral position to stop the motion of the boom. Move the switch down and hold to lower the boom. Release the switch to stop the boom motion.

4.7 MACHINE PLACEMENT

Each Bulk Feed unit must be properly placed prior to unloading to obtain the optimum performance. When positioning the machine, follow this procedure:

1. Clear the area of bystanders, especially small children, before moving the machine into position.
2. Inspect the parking or unloading position to be sure the surface is firm and level.
3. Drive the unit into its approximate unloading position with the tractor and trailer in a straight line and stop.
4. Do not position the unit on a surface that is not level or is so soft that one set of wheels can sink while the boom is rotating or the tanks are being unloaded. Boom rotation will shift the load on the axles when it is at 90° to the frame and can cause tipping if the suspension system flexes and one axle sinks into the ground.

IMPORTANT

Be sure the unit is on level ground during positioning or unloading to prevent tipping.

5. Do not position the unit where the boom will be closer than 30 feet (10 m) to overhead power lines when swinging the boom into position or unloading.
6. Set the parking brakes.
7. Deflate air suspension if so equipped.
8. Depress clutch and engage PTO driving the auxiliary hydraulic system.
9. Run the engine at 1000 RPM to provide oil to position the boom.
10. Dismount and open control box door.
11. Raise the boom out of its transport cradle.
12. Stay away from overhead power lines.

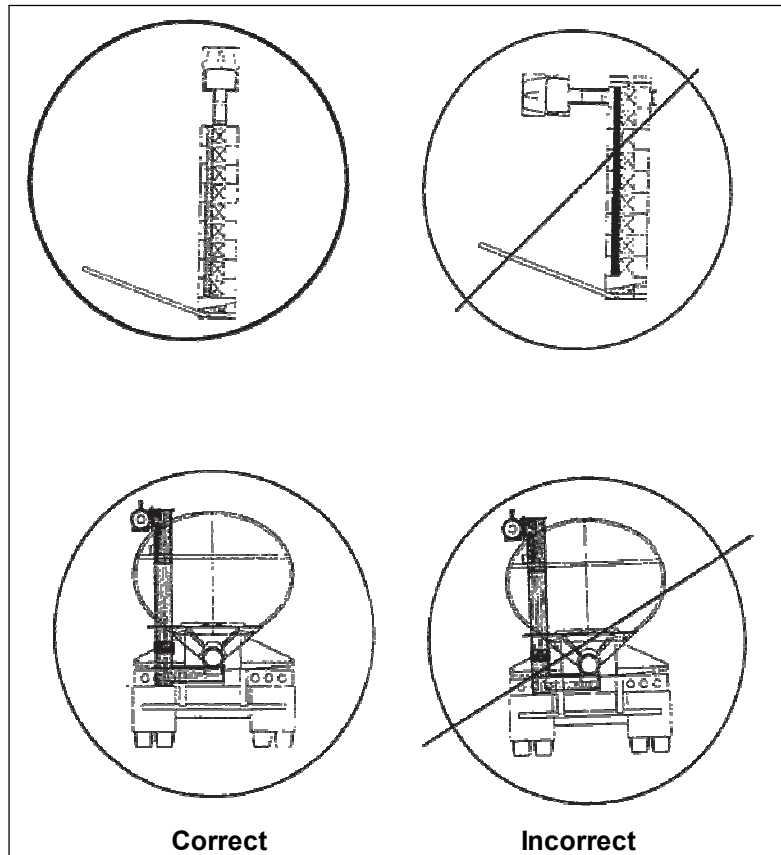
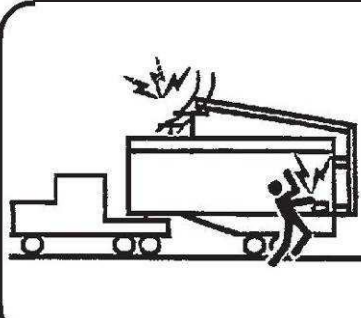

Fig. 4-15 PLACEMENT



Fig. 4-16 TRANSPORT CRADLE



DANGER

ELECTROCUTION HAZARD

To prevent serious injury or death from electrocution:

- Stay away from power lines when transporting and raising or lowering boom.
- Electrocution can occur without contacting power lines.

13. Slowly swing the boom around to the required position.

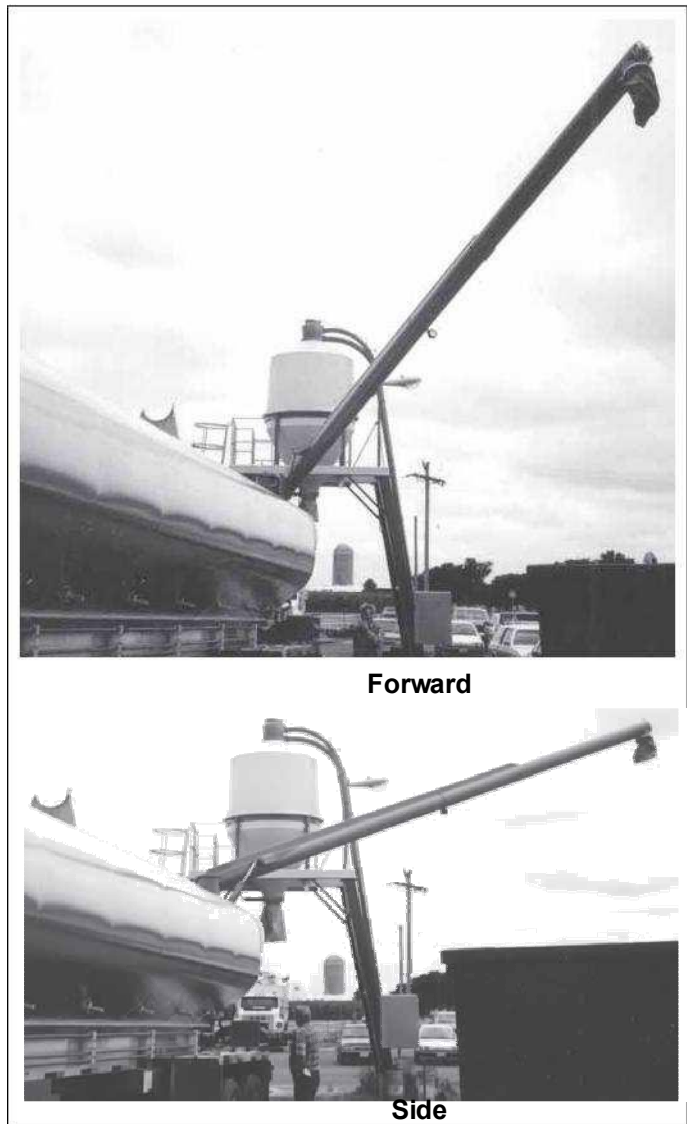

Fig. 4-17 BOOM ROTATION

14. Swing the boom to the left or the right as required for unloading, but watch the location of the boom drive hydraulic hoses. Do not pull the supply hoses tight when positioning the boom. If this occurs, swing the boom around the other direction or reverse the direction of the unit to keep the hoses slack.

IMPORTANT

It is recommended that the boom be positioned to the left side of the unit or behind it for unloading to eliminate tight hydraulic hoses. Drive in from the opposite direction if required.



Fig. 4-18 SUPPLY HOSES

15. Swing the boom around and position the boom discharge over the feed storage facility.

NOTE

It may be necessary to move the unit to centre the discharge in the opening.



Fig. 4-19 BOOM

16. Leave the boom a small distance above the storage structure. Do not rest the boom on the storage structure. Boom sag while unloading could damage the structure.
17. Then proceed to section 4.8 Operation for unloading procedure.
18. Reverse the above procedure when unloading is finished and stowing the boom prior to transport.

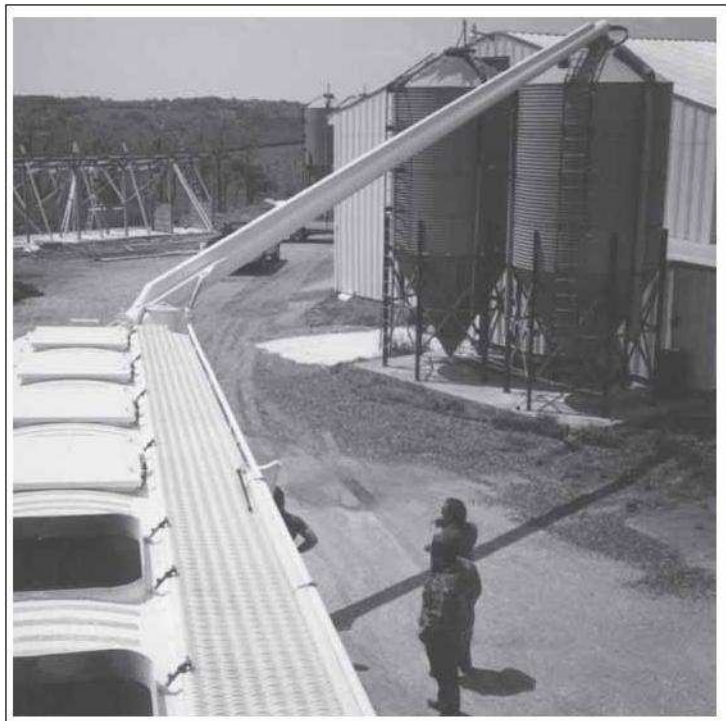

Fig. 4-20 POSITIONED

4.8 OPERATION



OPERATING SAFETY

1. Read and understand all the Operator's Manual and all safety signs before operating or adjusting the Walinga Bulk Feed unit.
2. Perform circle check before driving.
3. Do not allow riders outside the cab during road or highway travel.
4. Drive very carefully when negotiating hilly or uneven terrain.
5. Keep hands, feet, clothing and hair away from all moving parts.
6. Place all controls in neutral, disengage PTO clutch, stop the engine, set park brake, remove ignition key and wait for all moving parts to stop before servicing, adjusting, repairing or maintaining.
7. Stay away from power lines when moving boom or climbing on top of the trailer. Electrocutation can occur without direct contact.
8. Do not open access doors to airlocks, trough chain or augers while the air system or auger are running.
9. Use care when climbing on ladder(s) and/or platform(s) to prevent falling.
10. Maintain running gear in good condition at all times. In addition, on trailers, maintain king pin and fifth wheel assembly in good condition.
11. Clear the area of all bystanders, especially children, before starting up and operating the unit.
12. Make sure that all lights and reflectors that are required by the local highways and transport authorities are in place, clean and can be seen clearly by all overtaking and oncoming traffic.
13. Do not operate unit with spring brakes caged or brakes disabled. Block wheels if unhooked.
14. Before disconnecting the tractor from the trailer unit(s) make sure that the tractor and trailer are on level ground and that the trailer wheels are securely blocked. Lower landing gear and provide extra support if the ground is soft. Deflate air ride if so equipped prior to uncoupling.
15. Do not unload unless vehicle is on a firm level surface.
16. Review safety items with all personnel annually.

Follow these operating procedures to obtain maximum performance and long life:

1. Review and follow pre-operation inspection and checklist before operating.
2. Review the location and function of all controls.

4.8 OPERATION (cont'd)

3. Loading Unit:

- a. Drive the unit under conveyor or loading system.
- b. Check that all compartment gates are closed and locked.



Control

- c. Raise optional collapsible railing if so equipped.



Closed

Fig. 4-21 SLIDING GATES

- d. Open top covers over tanks.



Fig. 4-22 TOP COVER (TYPICAL)

- e. Fill the tank compartment(s) with desired material.

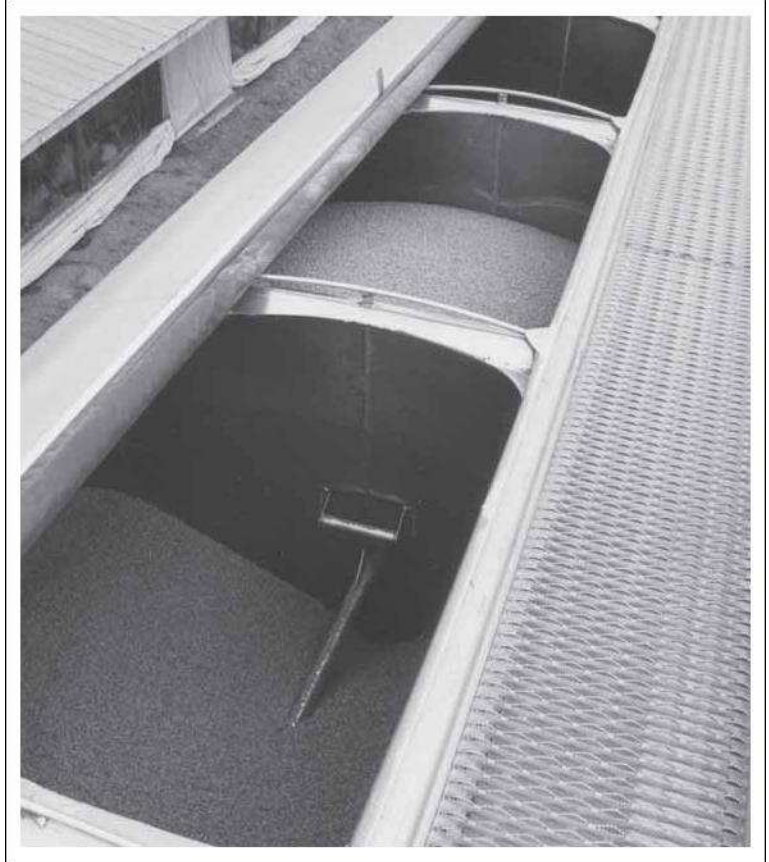

Fig. 4-23 FILLED COMPARTMENTS

- f. Close and secure the top cover(s).
- g. Lower collapsible railing if so equipped.



Fig. 4-24 COVERS CLOSED

- h. Transport to the unloading area.
- i. Position the unit per Section 4.7. Stay away from power lines and be sure the unit is on firm level ground.

4.8 OPERATION (cont'd)

6. Starting:

- a. Open control box door and place all controls in neutral or OFF/STOP position.
- b. Start engine, set engine at low idle (1000 RPM or less), disengage clutch, engage transmission, engage PTO for hydraulic system, disengage transmission (place in neutral), engage clutch. The PTO driving the hydraulic system has now been set.



Fig. 4-25 PTO CONTROLS

- c. Set engine speed at listed RPM to provide sufficient oil flow to the auger drive motors.
- d. Use the vertical and boom auger switch to start the vertical and boom auger drive motors.
- e. Using the Trough Auger Switch, start the trough conveyor drive motor.
- f. Using the Flow Control Switch start trough conveyor .

Turn counter-clockwise 2 turns from all the way in or until the boom pressure gauge is between 1500 and 2600psi (10245 and 17926kpa)

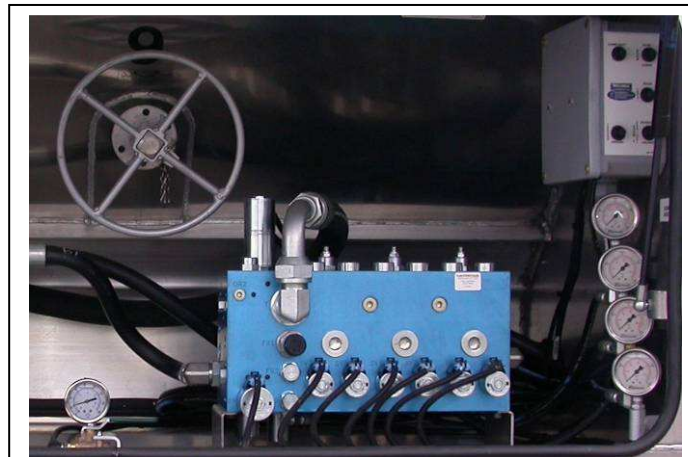

Fig. 4-26 CONTROLS

- g. Open required tank compartment sliding gate starting with rear compartment.



Fig.4-27 SLIDING GATE AT REAR

- h. Use the Manual Flow Control on the trough conveyor drive system to set the vertical and boom auger drive pressure at 1500 to 2600 psi (10245 to 17926 kPa) unloading capacity.

NOTE

Watch pressure on boom and vertical drive system gauge.

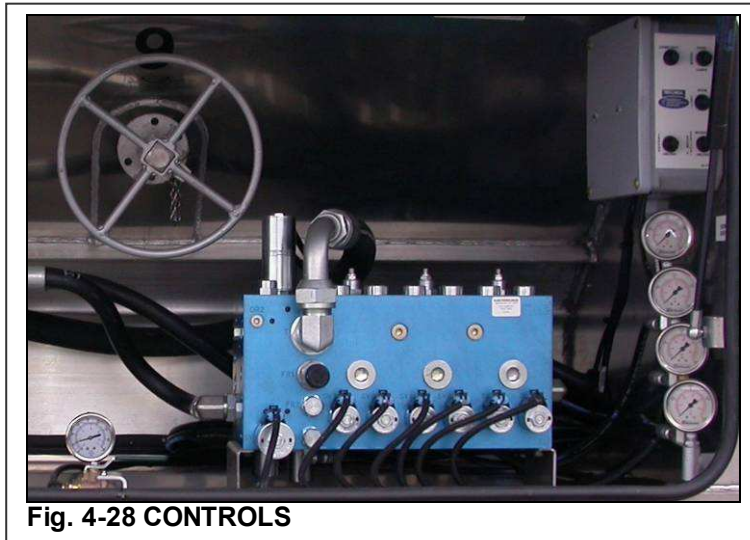

Fig. 4-28 CONTROLS

- i. Increase the speed of the trough conveyor until the material starts to back up in the sight glasses. Reduce conveyor speed slightly until material flows smoothly.
- j. When the compartment is empty, open the sliding gate over the next compartment. Repeat with the next compartment until all are empty.

IMPORTANT

Do not try to empty more than one compartment at a time while unloading. When more than one tank is open during unloading, the material can overload the trough conveyor and cause stalling or plugging.

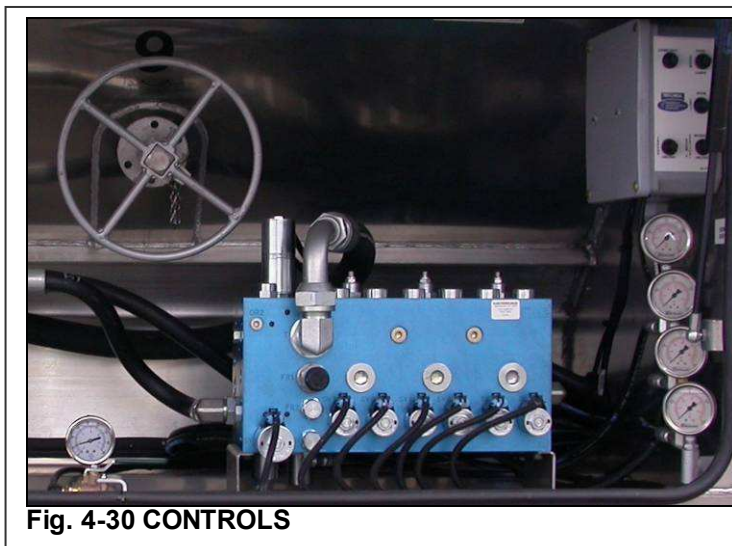

Fig. 4-29 SIGHT GLASS

4.8 OPERATION (cont'd)

7. Stopping:

- a. Turn trough conveyor OFF
- b. Turn vertical and boom augers OFF.
- c. Close all compartment gates and secure with safety pins.



- d. Reduce engine speed to low idle.
- e. Depress master clutch and disengage PTO clutch.



8. Emergency Stopping:

If an emergency occurs that requires immediate machine shut-down, place all controls in the control box in neutral/OFF to stop the machine or disengage PTO clutch.

Refer to Step 6 "Starting" and follow the procedure when restarting the machine. Remember, the augers are all full of material and the start-up loads will be higher than normal. Always return all controls to OFF before engaging the PTO drive.



9. **Maximum Capacity:**

The optimum operating conditions occur when the unloading system is providing maximum capacity. The system is designed so the vertical and boom augers are the limiting components. Set the system to obtain maximum capacity in the vertical and boom augers by:

- a. Increase the speed of the trough conveyor with the manual flow control in the control box until the vertical and boom drive system pressure runs between 1500 and 2600 psi (10245 to 17926Pa) and



Fig. 4-33a PRESSURE GUAGES

- b. The material is flowing smoothly and evenly across the sight glass.



Fig. 4-33b SIGHT GLASS

4.8 OPERATION (cont'd)

10. Unplugging:

When the unit plugs, follow this procedure to unplug:

- Place all controls in neutral/OFF.
- Disengage PTO clutch, stop engine, remove ignition key and wait for all moving parts to stop.
- Remove ignition keys.
- Close all the compartment gates.
- Open access cover on the back of the conveyor tube.
- Clean out the material from the back of the conveyor tube and the transition cross-over cavity.
- Close and secure access door.
- Start engine, engage PTO driving hydraulic pump and start the vertical and boom augers.
- If the augers will not move, run them in the reverse direction momentarily to dislodge the plug or jam. Then run again the forward direction.

NOTE

If the trough conveyor will not run in the forward direction after reversing momentarily, it will be necessary to shut down and clean the material out of the transition area again before resuming operation.

- Start the trough conveyor to bring material to the vertical and boom augers but run at a slower speed to reduce the pressure in the boom/vertical drive system.

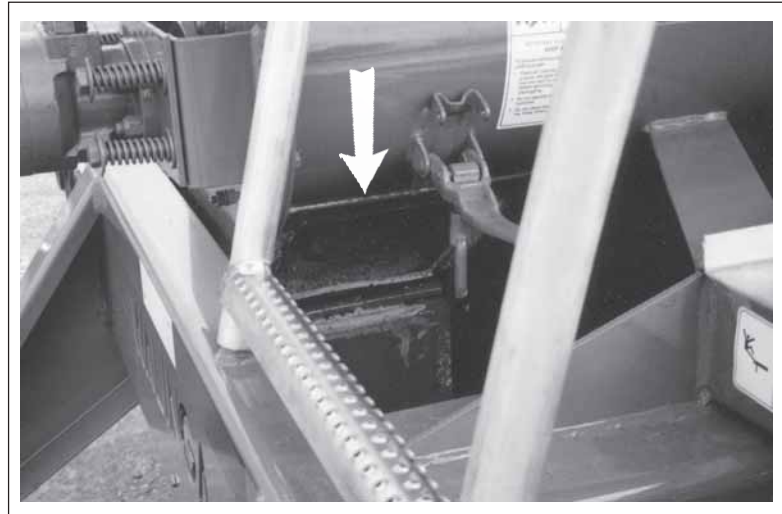

Fig. 4-34 ACCESS DOOR

! **DANGER**



**ROTATING AUGER HAZARD
KEEP AWAY**

To prevent serious injury or death from rotating auger:

- Place all controls in neutral, stop engine, set park brake, remove ignition key and wait for all moving parts to stop before servicing, repairing, adjusting or unplugging.
- Do not operate with the auger guards removed.
- Do not stand near augers when operating. Keep others away.

- If the trough conveyor plugs:
 - Disengage PTO, stop engine and wait for all moving parts to stop.
 - Open access door and clean out tube and transition.
 - Close and secure access door.
 - Close and secure gates at the bottom of each compartment.
 - Start engine, engage PTO, run vertical and boom augers and start trough conveyor.
 - Open the desired compartment gate only enough to provide material to the trough conveyor for unloading but not enough to plug it.



WARNING

Machine is shown with guard removed or access door opened for illustrative purposes only. Do not operate machine with guard removed or access door opened.

11. Operating Suggestions:

- a. Use only fully trained operators at all times. Review safety and operating instructions annually.
- b. Position the unit on a firm level surface to unload. Be sure the tractor and trailer are in a straight line for unloading to provide maximum stability.



Fig. 4-35 POSITION

- c. Empty the rear tank first when unloading. The empty tank will allow excess material to fill in if required as other compartments empty.
- d. Stay away from power lines when raising or swinging the boom, raising the collapsible railing or climbing on the top platform. Electrocutation can occur without direct contact.

	<p>! DANGER</p> <p>ELECTROCUTION HAZARD</p> <p>To prevent serious injury or death from electrocution:</p> <ul style="list-style-type: none">• Stay away from power lines when transporting and raising or lowering boom.• Electrocutation can occur without contacting power lines.
--	---

- e. Extend boom on the left side of the vehicle for unloading to keep boom drive motor hoses slack.



Fig. 4-36 LEFT SIDE

4.8 OPERATION (cont'd)

11. Operating Suggestions (cont'd):

f. Relief Valve:

The hydraulic circuit driving the boom rotation motor is equipped with a cross circuit relief valve to plumb oil to the opposite side of the circuit when the pressure exceeds a preset value. Should the boom strike an obstruction while rotating, the relief will open and stop the movement. In addition, if the truck is moving, the valve will bypass the oil to allow the boom rotation motor to run backwards and swing the boom out of the way.



Fig. 4-37 RELIEF VALVE

4.9 TRANSPORTING

Although all operating and transporting instructions are common sense, it is wise to review them periodically to refresh your memory. Good operational procedures result in a safe workplace for the operator and others.

4.9.1 OPERATING INSTRUCTIONS

Since this equipment can be used in a variety of conditions, it is difficult to give instructions appropriate for all applications. However, these general guidelines apply to all situations:

1. Be sure that the trailer is securely attached to the towing vehicle and locked into position.
2. Be sure that the air, hydraulic and electrical lines are securely connected and that they have sufficient slack for turns.
3. Be sure that the brakes are properly adjusted and in good working condition.
4. Be sure that the electrical harness is securely attached and all lights and reflectors are clean and operating.
5. Maintain the mud flaps in good condition to minimize road splash in wet conditions.
6. Always maintain the truck and trailer in good mechanical condition.

4.9 TRANSPORTING (cont'd)

4.9.2 BRAKING GUIDELINES

Safe, reliable and trouble-free operation of your unit requires that the brakes be maintained in good operating condition at all times and the driver follows good application techniques when driving. The irresponsible use of brakes by the driver when traveling can contribute to low brake life or result in system malfunctions, short life and poor tire wear patterns. The following list summarizes some basic operational guidelines for the driver.

1. Check the function of the brake system at the start of each day.
2. Maintain a safe vehicle speed at all times. Slow down for rough road or slippery surface conditions, winding roads or congested areas.
3. Always provide sufficient vehicle spacing on the road to allow for a safe stopping distance.
4. Apply brakes gradually to produce an even deceleration until the vehicle is stopped.
5. Watch traffic patterns ahead. Anticipate pattern changes that could result in an emergency. Apply the brakes gradually in sufficient time to produce a controlled stop.
6. Shift to a lower gear to use engine compression as the retarding force when going down steep grades.
7. Do not apply brakes for a long period of time such as when traveling on a long downgrade. The brakes will overheat. Instead, apply both the tractor and trailer brakes for short periods of time and the brakes have a chance to cool between applications.
8. Dry the brakes by applying them several times after going through water.
9. Release the brakes just before going over railroad tracks or other rough conditions. By allowing the wheels to turn over rough road surfaces, there will be no shock loads to the brake system components or produce flat spots on the tires.
10. Wet, icy or snow-packed surfaces require special care. Make cautious, intermittent applications by fanning or pumping the brakes to reduce speed without skidding or locking the wheels.
11. Use wheel chocks, apply trailer and tractor parking brakes and place tractor in low gear when parking the unit.
12. Maximum brake retarding occurs just before the wheels lock up and the tires skid. Release the brakes should you feel them lock-up and reapply them.
13. When trailer parking brakes are applied with hot drums, it may result in a cracked drum. Allow them to cool before reapplying the brakes.
14. Fanning or repeated on-and-off applications will use up the system air reserves. This procedure is not recommended unless adverse road conditions are encountered. The wasting of air reserves in this way could result in insufficient application pressure should an emergency arise.
15. Hard or panic stops can overheat the linings and drums. Overheating will cause brake fade. Severe overheating and fade can result in the complete loss of braking capability. This will substantially reduce the expected life of brakes.

4.9.3 TIRES

When operating the unit, it is the responsibility of the driver to check the tires frequently. Inflation pressures, wear patterns and matching are critical parameters that must be monitored. The following factors affect tire care:

1. **Inspection frequency:** Tires should always be checked at the start of a day and twice during the day or every 4 operating hours, whichever comes first. It is also a good practice to check the tires at each rest period during the day. When a driver hears unusual noise or experiences unusual handling characteristics, the first item to check is the tires. Problems found early, during frequent tire checks, can save more serious problems later on. A sampling of typical abnormal wear patterns are shown in the Maintenance section along with their causes. Always correct the cause of the tire wear problem before proceeding.
2. **Inflation pressure:** Tires should always be operated at their specified pressures. At their specified pressures, the tire is designed to run with the full width of the tread flat on the contact surface. Operating at other than specified pressures will change the tread contact patterns and can dramatically shorten tire life. In addition, the tires will run hotter and can lead to blow-outs.

Check tire pressure when the tire is cold. A hot tire can read as much as 20 psi higher than a cold tire. If tires are over-inflated, check for poor load distribution, uneven surface contact, over-loading or poor operating conditions.

3. **Tire matching:** Do not mix ply types on the same axle. Their operating characteristics are different and will lead to uneven tire loading, rapid tire wear and adverse handling characteristics. Matching also includes combining tires that have the same amount of tread remaining. A tire with more tread has a larger rolling radius and will have to carry a higher load. The best performance will be obtained when the rolling radius is within 1/8" for all tires on an axle.

4.10 OPTIONAL EQUIPMENT

The trailers can be equipped with several options or attachments to adapt it to special customer requirements.

1. Several types of compartment covers are available. Select the style that best fits your application.



Air Opened



Individual



Canvas

Fig. 4-38 COVERS

2. **Collapsible Railing:**

A collapsible railing is available for the top platform and is raised and lowered with an air cylinder. Always lower it when transporting to bring the vehicle height within legal limits.



Fig. 4-39 COLLAPSIBLE RAILING

3. **Suspension Systems:**

A variety of types and styles of running gear is available for use on the trailer including air or mechanical suspensions. Select the type that best suits your application.

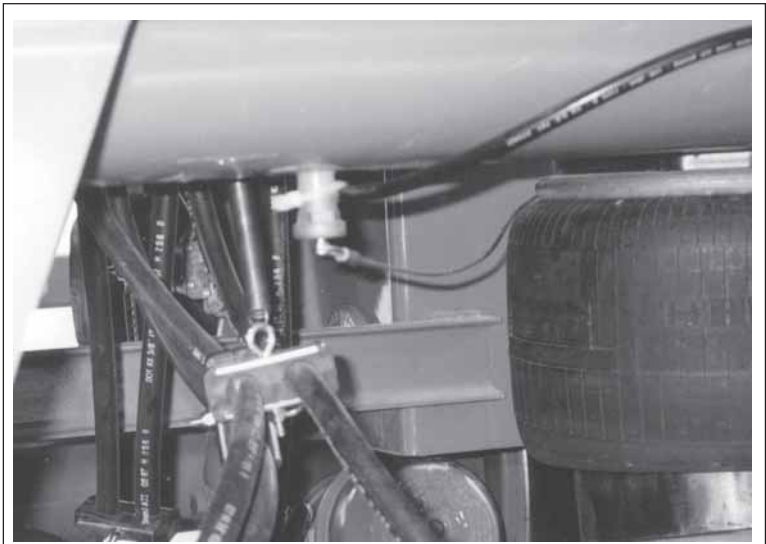

Air



Mechanical

Fig. 4-40 SUSPENSION TYPES

5 SERVICE AND MAINTENANCE

Review the manual provided with the truck for service and maintenance information.

This section provides information on daily and periodical service and maintenance of the Trailer unit. Follow these recommendations for safe and dependable operation of the Trailer unit. Refer to the safety section at the front of the operator's manual for all applicable safe maintenance and operating procedures.

Be sure that all operators are familiar with the operation and maintenance procedures and related safety information contained in the operator's manual.



MAINTENANCE SAFETY

1. Read and understand all the information in the Operator's Manual regarding maintenance, adjusting and servicing the Bulk Feed unit.
2. Place all controls in neutral, disengage PTO clutch, stop the engine, remove ignition key and set the park brake before adjusting, servicing or maintaining any part of the Bulk Feed unit.
3. Follow good shop practices:
 - Keep service area clean and dry.
 - Be sure electrical outlets and tools are properly grounded.
 - Use adequate light for the job at hand.
4. Block wheels before de-activating brakes.
5. Maintain air system and brake components in top condition at all times.
6. Maintain fasteners in running gear systems at their specified torque at all times.
7. Establish and maintain a Trailer Preventative Maintenance (TPM) program on your equipment. Some jurisdictions require this program and the maintenance of records on every commercial vehicle on the road for future reference.

5.1 SERVICE

5.1.1 FLUIDS AND LUBRICANTS

1. **Grease:**
Use an SAE multi-purpose lithium based grease with extreme pressure (EP) characteristics.
2. **Wheel Hub Oil:**
 - a. Use an SAE 80W90 for normal temperature conditions (-10°F to 100°F ambients).
 - b. Use an SAE 85W140 for hot temperature conditions (100°F and hotter ambients).
 - c. Use an SAE 30W motor oil for ambients below -10°F.

Capacity: 1 pint (500 ml) approximately

3. **Hydraulic Oil:**
Refer to 5.1.3 for Hydraulic Oil Specifications.
4. **Storing Lubricants:**
Your unit can operate at top efficiency only if clean lubricants are used. Use clean containers to handle all lubricants. Store them in an area protected from dust, moisture and other contaminants.

5.1.2 GREASING

Refer to Section 5.1.1 for recommended grease. Use the Service Record checklist provided to keep a record of all scheduled servicing.

1. It is recommended that a hand-held grease gun be used for greasing. An air-powered greasing system can damage the seals on bearings and lead to early failure.
2. Wipe grease fitting with a clean cloth before greasing, to avoid injecting dirt and grit.
3. Replace and repair broken fittings immediately.
4. If fittings will not take grease, remove and clean thoroughly. Also clean lubricant passageway. Replace fitting if necessary.

5.1.2 Greasing (cont'd)

NOTE:

When greasing bearings it is very important that bearings are not over-greased.

The use a handgun is recommended .

When greasing bearings once a month or every 10,000 miles apply only one pump of grease per bearing. This applies to all auger and paddle bearings when servicing the unloading system. (for details and specs on greasing refer to section 5 and 7 of this operator's manual)

IF A BEARING IS OVER-GREASED IT WILL VOID THE WARRANTY

5.1.3 HYDRAULIC SYSTEM

1. Oil Specifications:

PUMP MODEL	Min. Start-up (No Load)	Minimum Operating Temperature	Maximum Operating Temperature
P197 (PERMCO)	-16°C/3°F	-2°C / 28°F	82°C /180°F
P3100 / P5000/ DMD25-064 (PERMCO)	-16°C/3°F	-10°C / 14°F	82°C /180°F

NOTE:

To avoid damage to equipment HYDREX* XV hydraulic oil must be used. The use of alternative hydraulic oils without Walinga's written consent may void the terms of the equipment warranty.

- a. All hydraulic systems will be filled with Hydrex XV.
- b. Check with dealer or factory for oil requirements when using other oils or in other temperature ranges.
- c. When operating a unit and the oil temperature is over 180°F (82°C), the pump system must be shut down, or run slower until the system cools down.
- d. If overheating persists, check the system for possible causes (see Section 10.7).
- e. Hydraulic oil filter must be changed before the gauge needle is in red on 10 MICRON return filters.
- f. Hydraulic oil should be checked regularly. (Testing of oil is recommended once a year).
- g. Always maintain a proper level in the hydraulic tank and keep oil clean.
- h. Do not over speed the hydraulic pump, it causes overheating of the hydraulic oil. (Run the engine as shown on RPM tag on dash).
- i. Check vent filler cap and keep it clean.

2. System Operation:

- a. Be sure your oil specifications meet or exceed the pump manufacturer requirements.
- b. Do not exceed starting and operating temperatures as specified above.
- c. When operating a unit and the oil temperature is over 180°F (82°C), the pump system must be shut down, or run slower until the system cools down.

6 TRAILER SERVICING INTERVALS

A standard servicing schedule on your trailer unit is provided as a guide for your convenience. In unusual or extreme operating conditions, increase the frequency or perform additional service items to customize this schedule to your application.

Refer to the Service Section of the truck manual for truck servicing information.

A. Servicing: 8 Hours, Daily or 500 Miles

1. Drain moisture from air tanks (use cables to open drain valves).



Tank Drain



Valve

Fig. 6-1 DRAIN CABLE(S) (TYPICAL)

2. Check tire air pressure. Add as required.



Fig. 6-2 TIRES (TYPICAL)

Weekly, 10 Days or 5000 Miles

1. Grease slack adjusters
(1 location each adjuster).

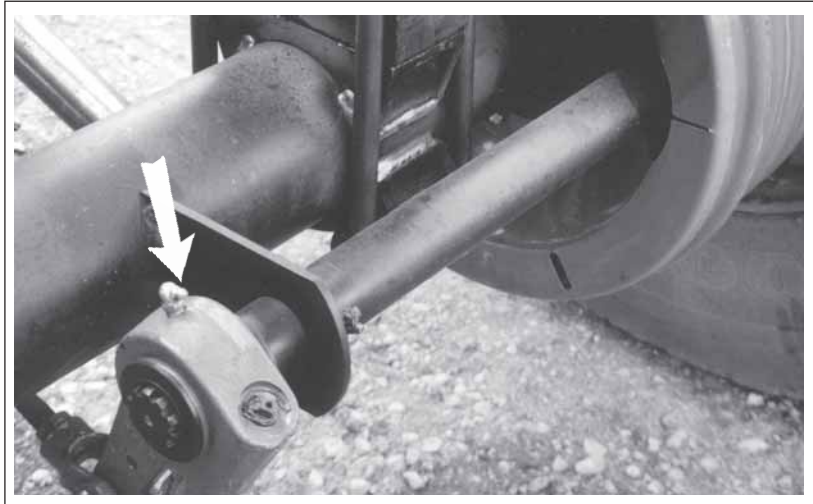

Fig. 6-3 SLACK ADJUSTER (TYPICAL)

2. Grease camshaft bearings
(1 location each camshaft).

IMPORTANT

Do not overgrease.



Fig. 6-4 CAMSHAFT BEARING

Weekly, 10 Days or 5000 Miles (cont'd)

3. Check wheel hub oil levels.

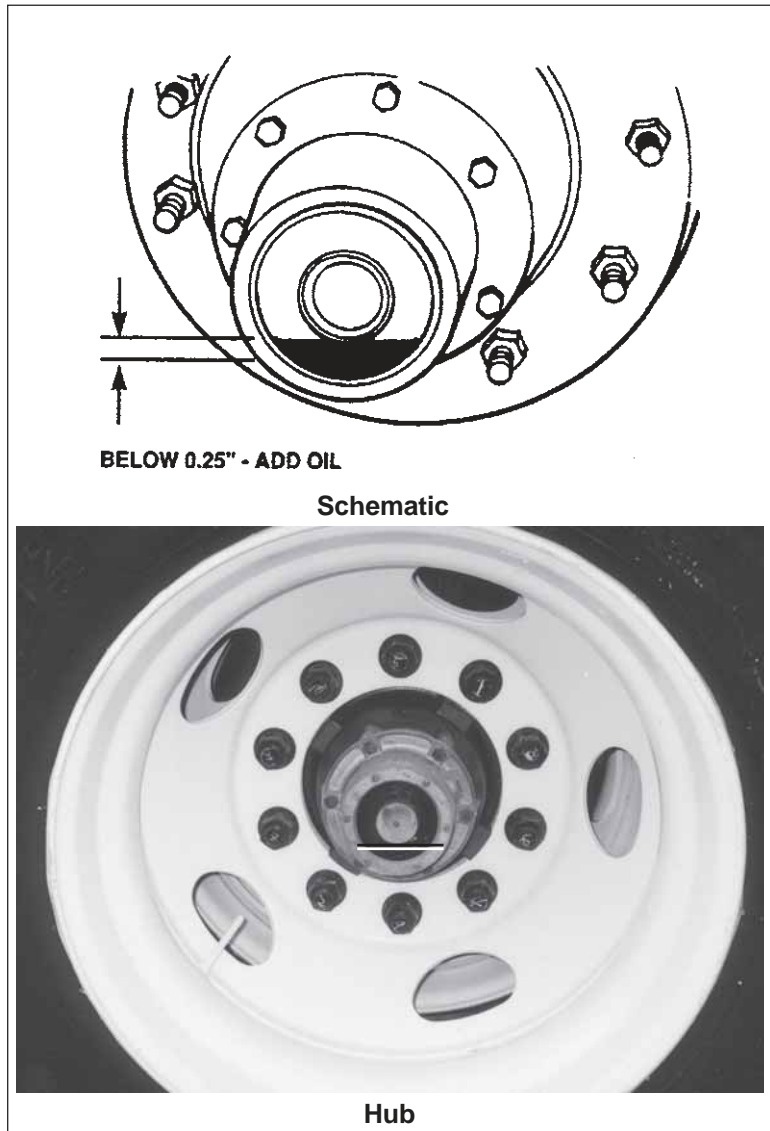

Fig. 6-5 HUB OIL LEVEL

4. Retorque the following fasteners:

- a. Brake/wheel end system fasteners. Refer to Section 8.8.

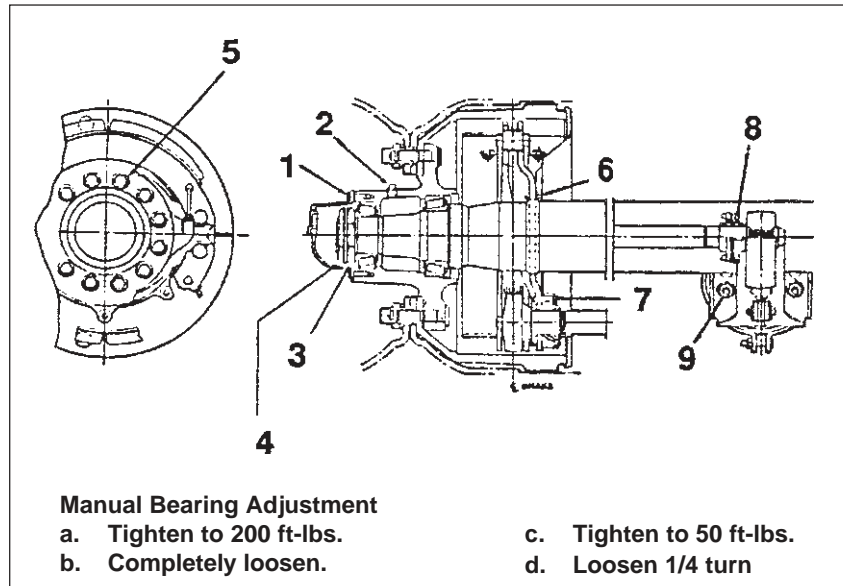

Fig. 6-6 BRAKE/WHEEL END

- b. Landing gear bolts.

1/2 in. 115 ft. lbs
5/8 in. 220 ft. lbs



Fig. 6-7 LANDING GEAR MOUNTING BOLTS

Weekly, 10 Days or 5000 Miles (cont'd)

- c. Retorque cast spoke wheel rim nuts if so equipped.

Table 1 Recommended Wheel Bolt Torque (Spoke Wheels)

Bolt Size	Ft-lbs Torque (Dry)
5/8" - 11	150 - 175
3/4" - 10	210 - 260

IMPORTANT

Do not over-torque fasteners. Over-torquing can strip threads, collapse spacers or lead to other problems that cause loose fasteners. Use an accurate torque wrench when tightening fasteners.

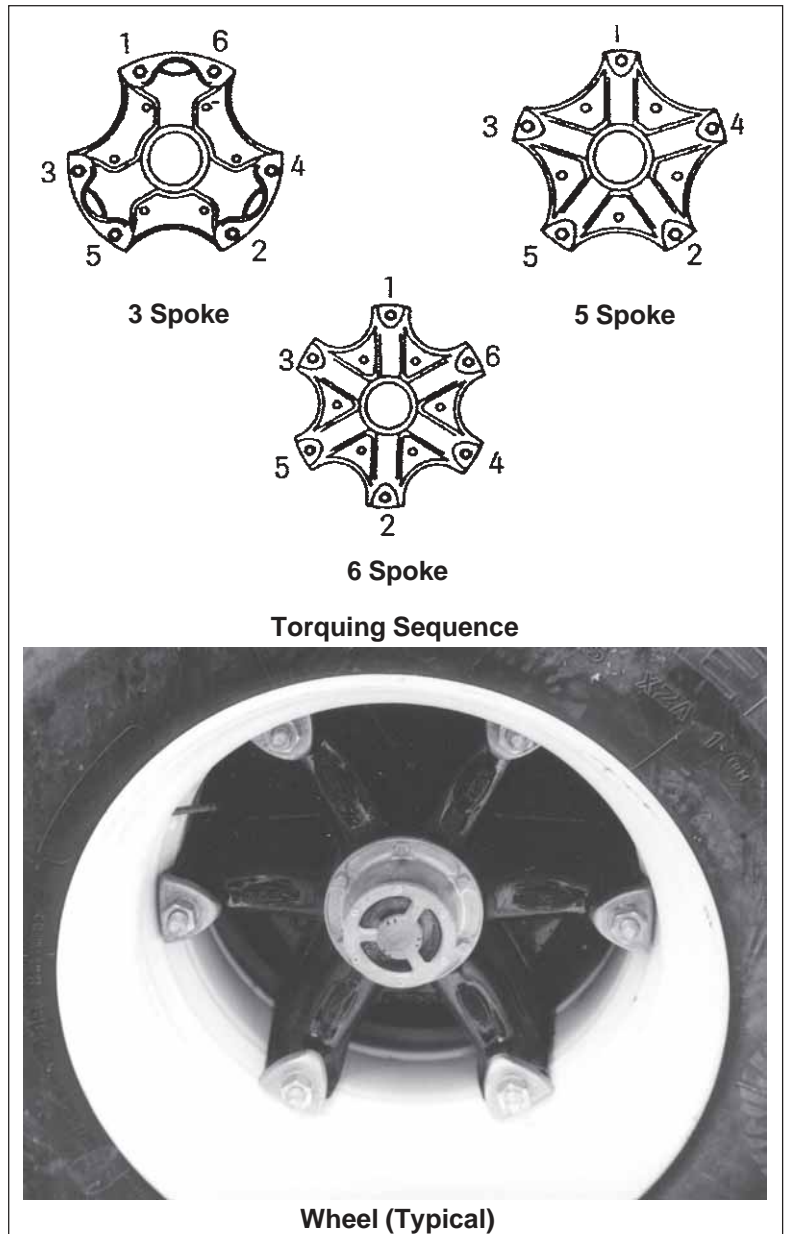

Fig. 6-8 CAST WHEEL RIM NUTS

Weekly, 10 Days or 5000 Miles
(cont'd)

- d. Retorque for stud pilot inner and outer wheel nuts if so equipped.

Table 2 Recommended Wheel Stud Torque (Disc Wheels)

Stud Size	Wheel Type	Ft-lbs Torque (Dry)
3/4" - 16	Disc	450 - 500
1-1/8" - 16	Disc	450 - 500
15/16 - 12	Disc	750 - 900
1-5/16 - 12	Disc	750 - 900
	Bud Unimount 10	390 - 440
	WHD-8	400 - 600

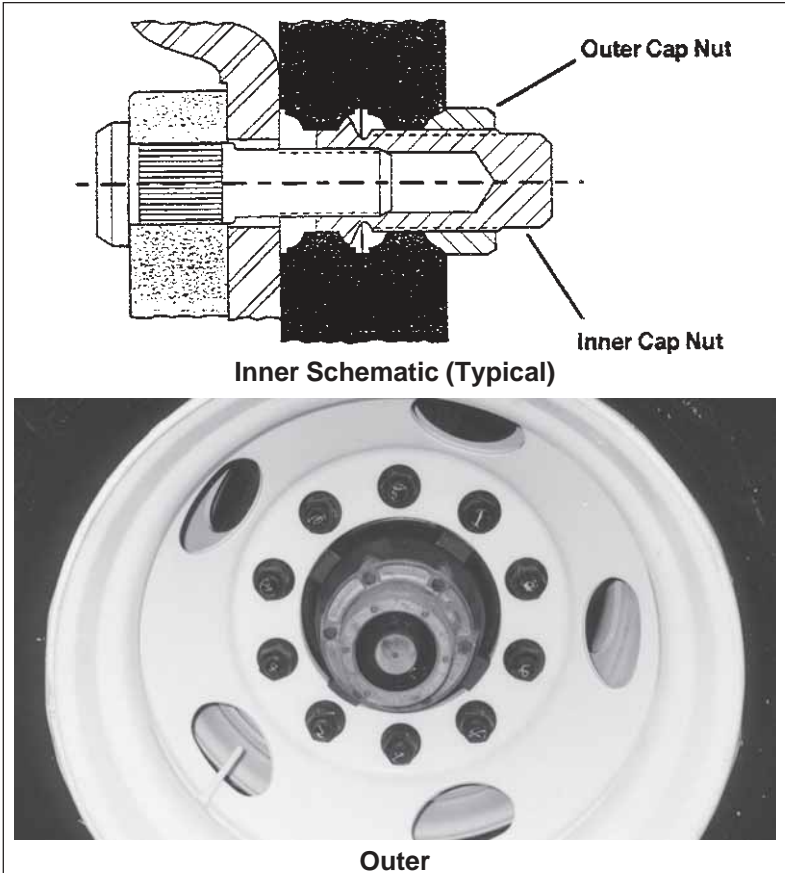

Fig. 6-9 10 STUD WHEEL NUTS

- e. Retorque hub piloted wheel single nuts if so equipped.

Table 3 Recommended Wheel Stud Torque

Stud Size	Ft-lbs Torque (Oiled)
M22 x 1.5 (33 mm or 1-1/2 Hex)	450 - 500
M20 x 1.5 (30 mm Hex)	280 - 330

IMPORTANT

Do not over-torque fasteners. Over-torquing can strip threads, collapse spacers or lead to other problems that cause loose fasteners. Use an accurate torque wrench when tightening fasteners.

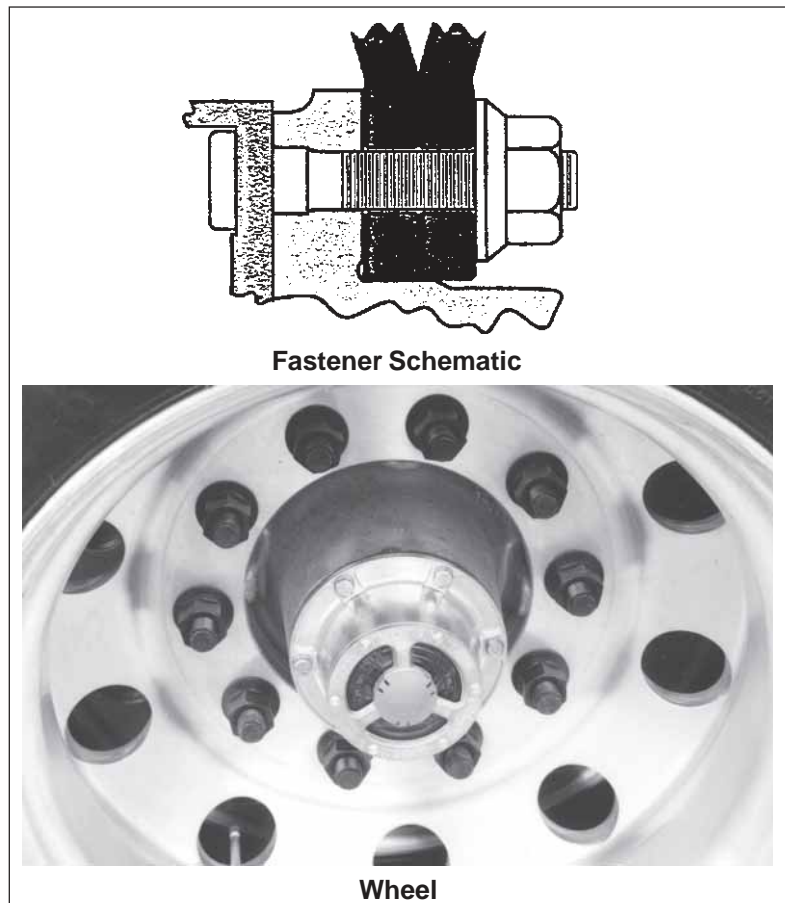

Fig. 6-10 SINGLE NUTS

Weekly, 10 Days or 5000 Miles (cont'd)

- f. Retorque suspension system fasteners. (Refer to charts for torque levels in Maintenance Section 8.1.)

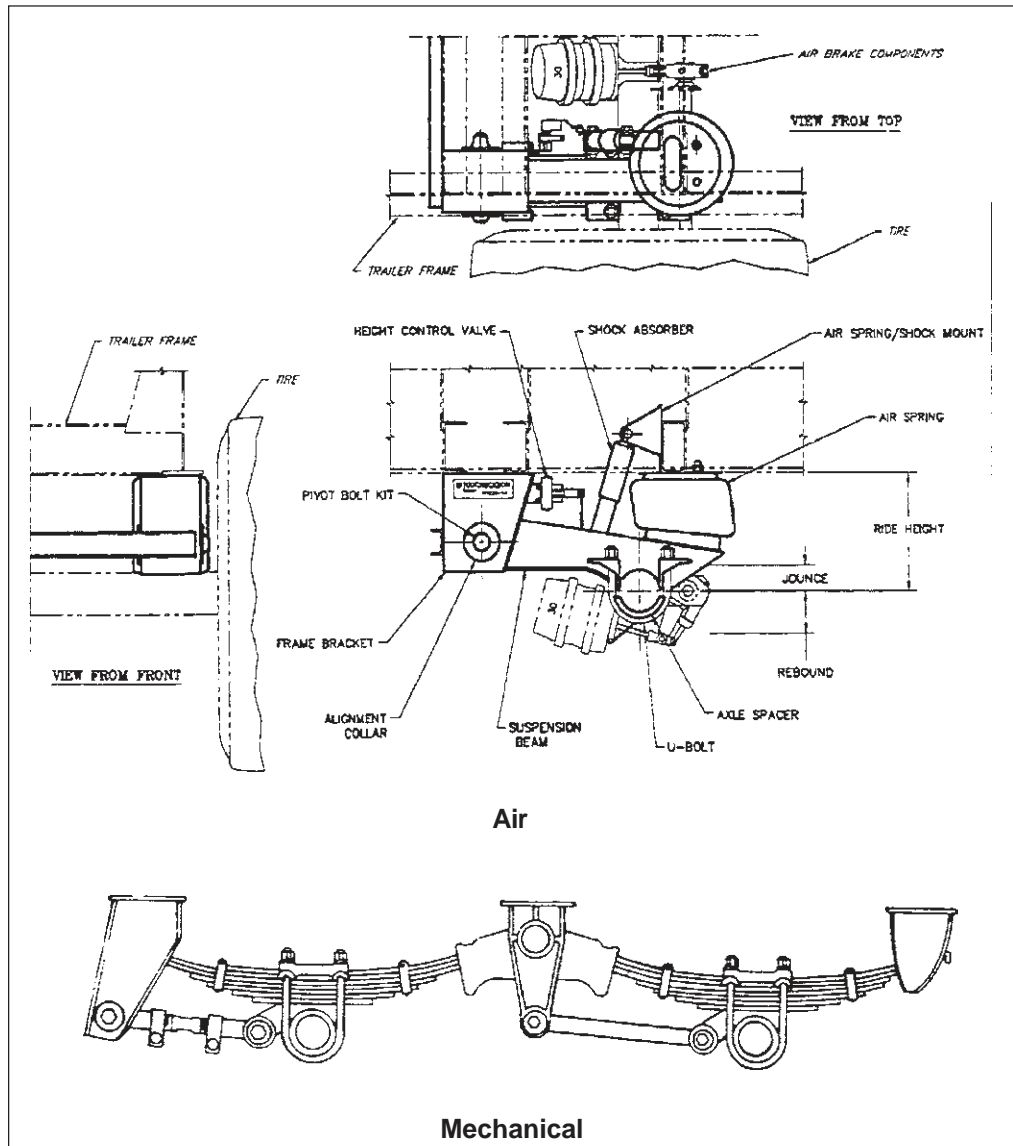

Fig. 6-11 SUSPENSION SYSTEM U-BOLTS

10,000 Miles (15,000 km) or Monthly

1. Grease landing gear bearings.



Fig. 6-12 LANDING GEAR

2. Retorque landing gear and suspension.
 - a. Landing gear.
 - b. Torque mechanical system suspension (refer to Section 8.1).

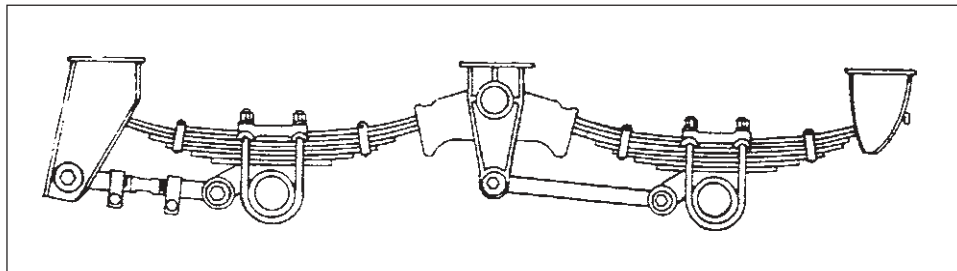

Fig. 6-13 MECHANICAL SUSPENSION SYSTEM

25,000 Miles (40,000 km), Quarterly or Every 3 Months

1. Check condition of wheel ends.
Release brakes, jack up the axle and spin the wheel. Check:
 - a. Wheel bearings.
 - b. Wobble.
 - c. Rims and tires.
 - d. Brake drag.



Fig. 6-14 WHEEL END

2. Inspect frame and structure for bends, distortions or cracks.
 - a. Kingpin.
 - b. Fifth wheel and mounts.
 - c. Longitudinal and transverse frames.
 - d. Compartment structure.
 - e. Unloading system structure.
 - f. Suspension system anchorage.
 - g. Axles.
 - h. Optional Accessories
 - i. Side Covers
 - ii. Top Covers



Fig. 6-15 TRAILER (TYPICAL)

3. Inspect electrical system components for:
 - a. Binding.
 - b. Rubbing/abrasion.
 - c. Looseness/dangling.
 - d. Cracks/tears in harness.
 - e. Burned out lights.

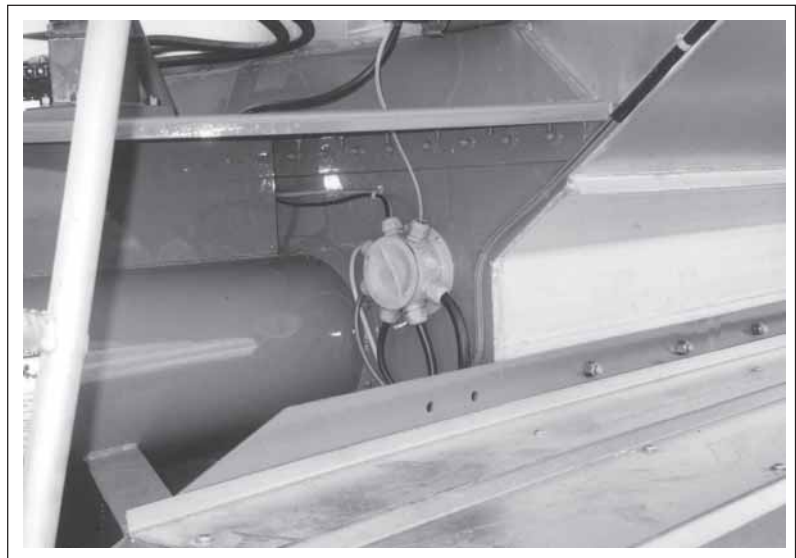

Fig. 6-16 ELECTRICAL (TYPICAL)

4. Inspect air system and components for:
 - a. Leakage by performing leak-down test.
 - b. Rubbing/abrading.
 - c. Cracked hoses.



Fig. 6-17 AIR SYSTEM (TYPICAL)

5. Clean gladhand screens if so equipped.

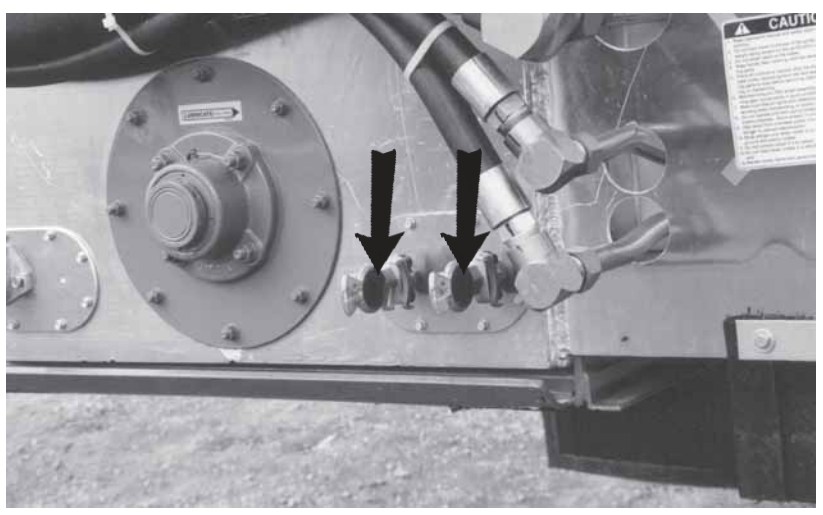

Fig. 6-18 SCREENS

6. Check brake lining thickness. Replace as required.

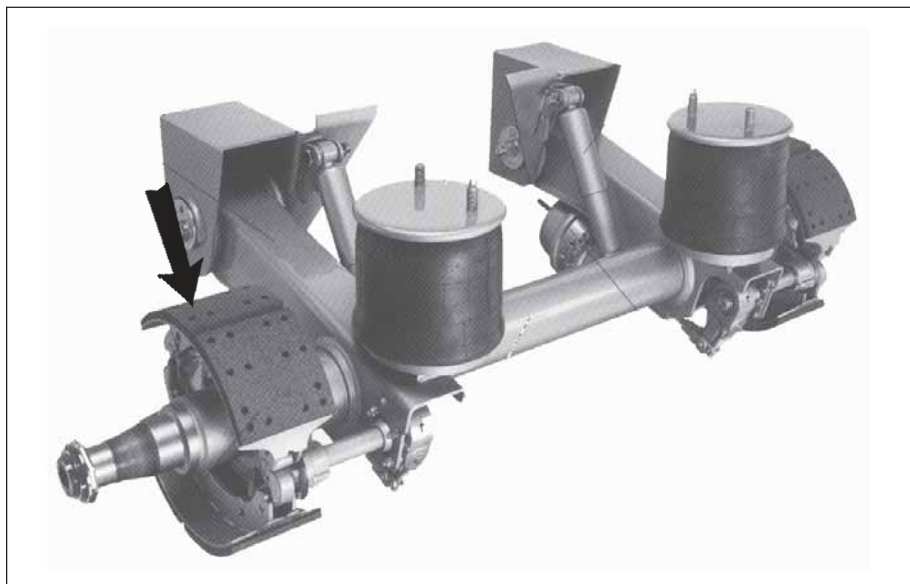

Fig. 6-19 BRAKE LINING

100,000 Miles (150,000 km) or Annually

1. Reline brakes as required.

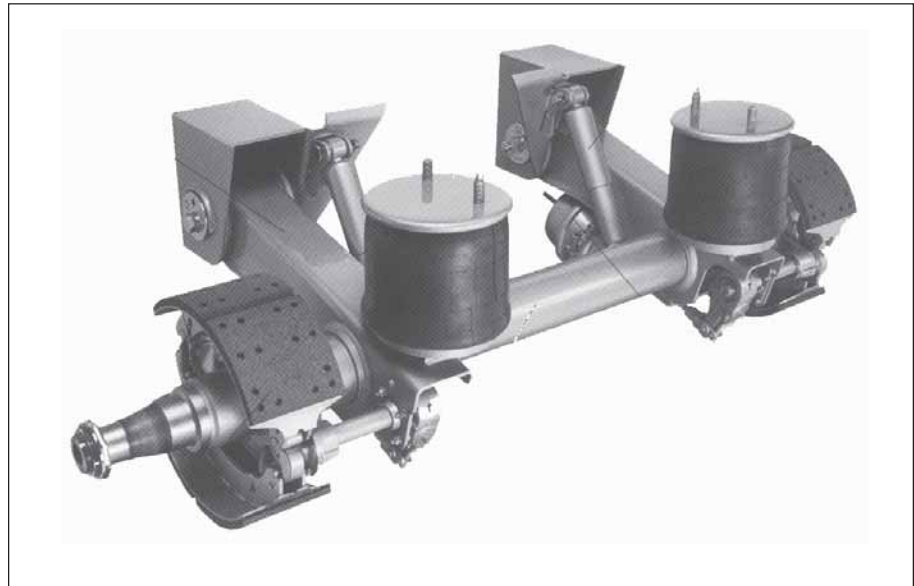

Fig. 6-20 BRAKES

2. Change oil in hubs.



Fig. 6-21 HUB OIL (TYPICAL)

6.1 SERVICE RECORD SUMMARY (LUBRICATION)

LOCATION	DESCRIPTION	FREQUENCY	LUBRICANT
Fifth wheel. Coat pivot pins and lock	Coat bearing surface.	Daily or as needed.	Chassis grease.*
Landing gear	Gearbox and screws.	Periodic basis (weekly).	Chassis grease.*
Wheels	Check oil level.	Weekly, 10 Days or 5000 m (8000 km)	
	Bearings.	25,000 miles (40,000 km).	SAE 80W90 gear oil.
Brakes	Change oil.	100,000 miles (150,000 km).	SAE 80W90 gear oil.
Camshaft bearing	Lubricate	5,000 miles (8,000 km) or monthly.	Chassis grease.*
Slack adjuster	Lubricate	5,000 miles (8,000 km) or monthly.	Chassis grease.*
Brake shoe anchor pin bushing	Lubricate	30,000 miles (50,000 km) or yearly.	Chassis grease.*
Also at brake reline.		As appropriate.	
* Use a good quality lithium based extreme pressure grease throughout. MIL-G-25013C in below -40°F.			
NOTE: Do not use excessive lubricant.			

7 UNLOADING SYSTEM SERVICING

7.1 SERVICING INTERVALS

8 Hours, Daily or 500 Miles

1. Check condition of hydraulic system filter.

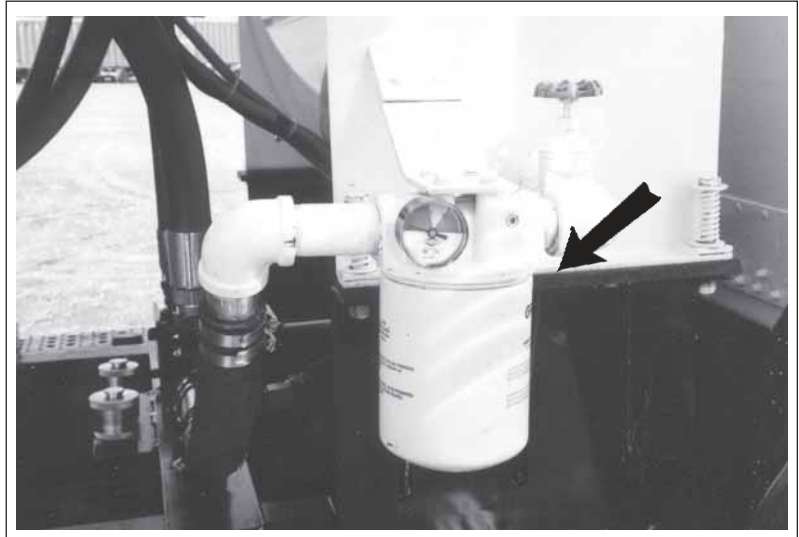

Fig. 7-1 HYDRAULIC SYSTEM FILTER

Weekly, 10 Days or 5000 Miles

1. Grease trough auger bearings front.

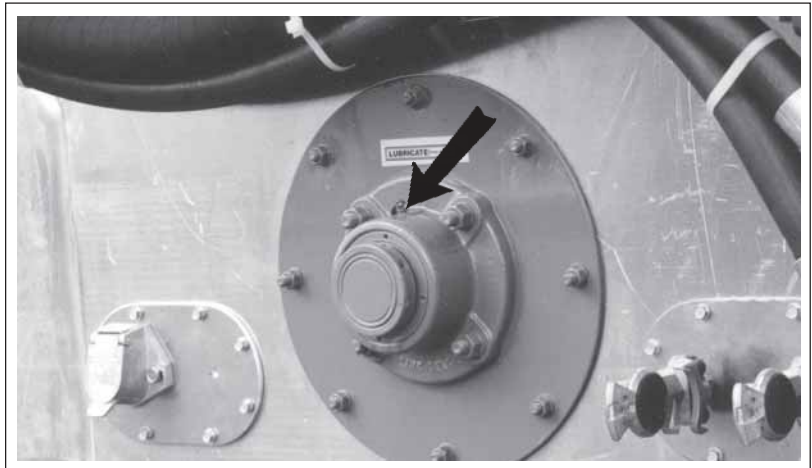

Fig. 7-2 TROUGH AUGER BEARINGS FRONT

Monthly or 10,000 Miles (15,000 Km)

1. Grease trough auger bearings rear.

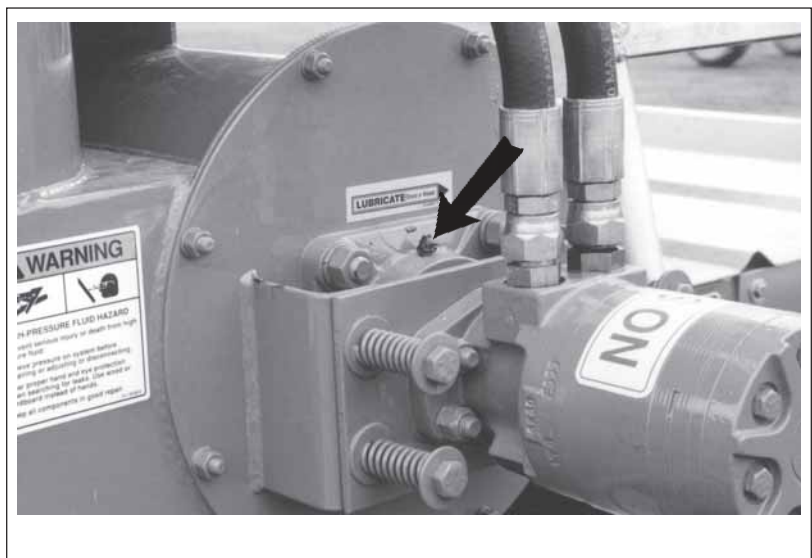
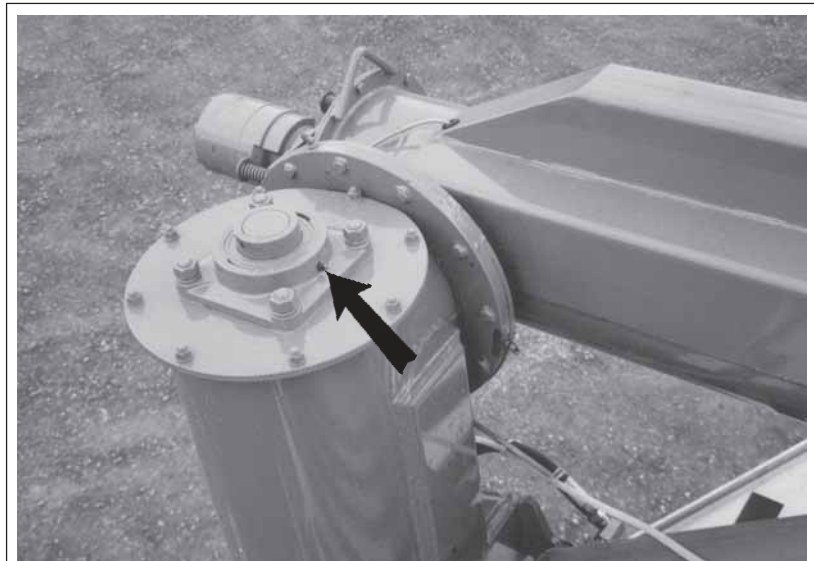

Fig. 7-3 TROUGH AUGER BEARINGS REAR

Monthly or 10,000 Miles (15,000 Km) (cont'd)

2. Grease the vertical auger: top and bottom.



Top

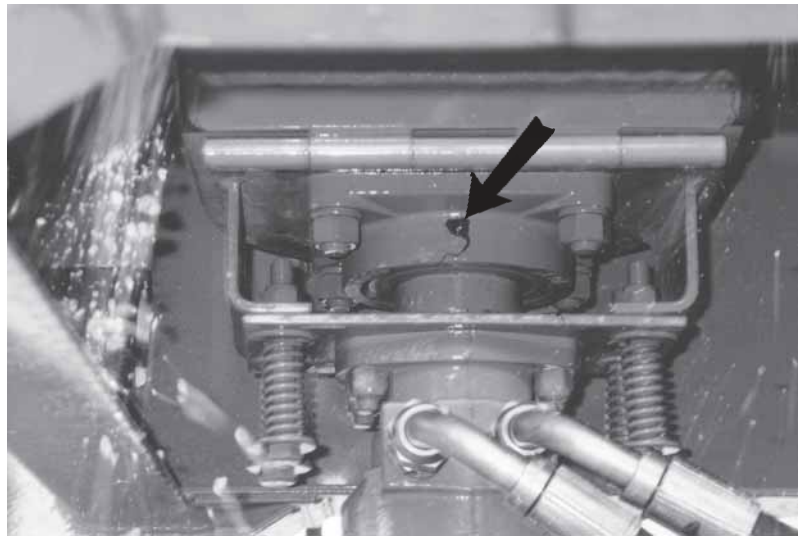

Bottom

Fig. 7-4 VERTICAL AUGER

- Grease boom auger bearings: drive, driven and support bearings, if so equipped.



Drive

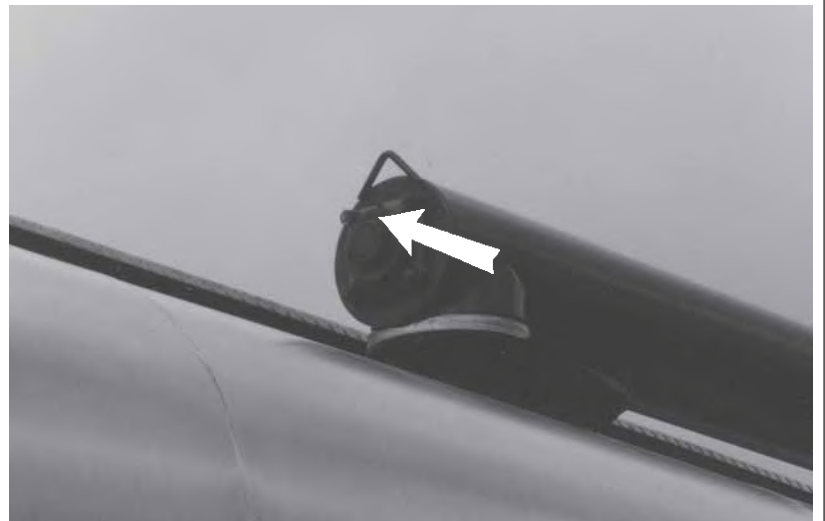

Driven



Support

Fig. 7-5 BOOM AUGER BEARINGS

Monthly of 10,000 Miles (15,000 Km) (cont'd)

- Grease boom rotation collar.



Fig. 7-6 BOOM ROTATION COLLAR

- Grease boom lift collar.



Fig. 7-7 BOOM LIFT COLLAR

- Grease or oil boom rotation drive roller chain.

IMPORTANT

Lift boom out of saddle and rotate to left 270° while lubricating chain then rotate back to right 360°. When lubricating chain ensure that complete chain gets lubricated. Rotate 360°.



Fig. 7-8 ROTATION DRIVE ROLLER CHAIN

7. Grease the boom lift cylinder bushings (each end).



Fig. 7-9 LIFT CYLINDER BUSHINGS

8. Grease the boom rotation drive sprocket shaft.

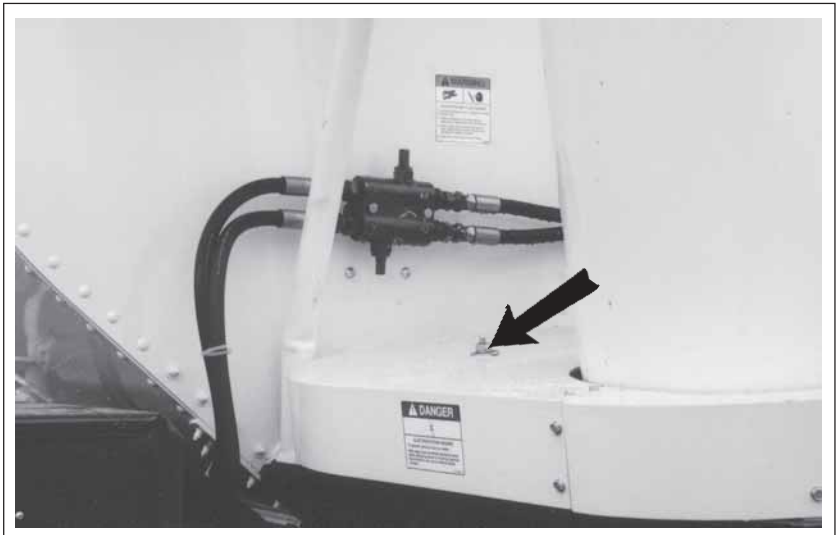

Fig. 7-10 BOOM ROTATION DRIVE SPROCKET

9. Grease the tank sliding gate shafts.



Fig. 7-11 SLIDING GATE SHAFTS

100,000 Miles (150,000 km) or Annually

1. Change hydraulic system oil.



Fig. 7-12 DRAIN PLUG

2. Change hydraulic system filter(s).

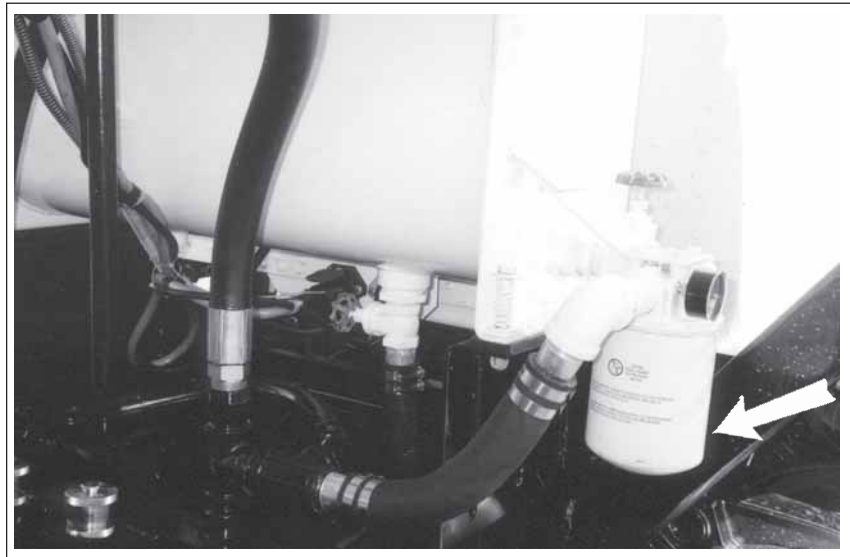

Fig. 7-13 FILTER

7.2 SERVICE RECORD

See Lubrication and Maintenance sections for details of service. Copy this page to continue record.

ACTION CODE: L LUBRICATE C CHANGE
 § CHECK

<div style="text-align: center;"> HOURS SERVICED BY MAINTENANCE </div>																				
	8 Hours, Daily or 500 Miles																			
§ Hydraulic System Filter																				
Weekly, 10 Days or 5000 Miles																				
L Trough Auger Bearings front																				
10,000 Miles or Monthly																				
L Trough Auger Bearings rear																				
L Vertical Auger - Top & Bottom																				
L Boom Auger Bearings																				
L Boom Rotation Collar																				
L Boom Lift Collar																				
L Boom Rotation Dr. Roll Chain																				
L Boom Lift Cylinder Bushings																				
L Boom Rotation Dr Sprcktt Shaft																				
L Tank Sliding Gate Shafts																				
100,000 Miles or Annually																				
C Hydraulic System Oil																				
C Hydraulic System Filter(s)																				

8 PERIODIC MAINTENANCE AND ADJUSTMENTS



MAINTENANCE SAFETY

1. Read and understand all the information in the Operator's Manual regarding maintenance, adjusting and servicing the Bulk Feed unit.
2. Place all controls in neutral, disengage PTO clutch, stop the engine, remove ignition key and set the park brake before adjusting, servicing or maintaining any part of the Bulk Feed unit.
3. Follow good shop practices:
 - Keep service area clean and dry.
 - Be sure electrical outlets and tools are properly grounded.
 - Use adequate light for the job at hand.
4. Block wheels before de-activating brakes.
5. Maintain air system and brake components in top condition at all times.
6. Maintain fasteners in running gear systems at their specified torque at all times.
7. Establish and maintain a Trailer Preventative Maintenance (TPM) program on your equipment. Some jurisdictions require this program and the maintenance of records on every commercial vehicle on the road for future reference.

Your trailer can only operate at top efficiency when it is maintained in good operating condition. The maintenance procedures are summarized from the component manufacturers instructions included with this manual. Only standard industry and component procedures are required to keep your trailer in top condition. All maintenance intervals are established for normal operating conditions. In light or intermittent conditions, the servicing and maintenance intervals can be extended. In heavy, extended or severe off-highway application, reduce the intervals for servicing and maintenance to keep the equipment in good condition. When a problem is found, correct the condition before continuing.

A good maintenance program will find conditions early when they are easily and quickly corrected before they become major problems. Operating your trailer in a defective condition, can lead to serious mechanical problems or can create safety hazards for the driver, bystanders or other operators.

8.1 TORQUE SPECIFICATION SUMMARY

Table 1 Recommended Torque Specifications

1. Air Ride Suspension		
Description	Size	Torque
Quik-Align™ Pivot Bolt	7/8"-9	475-525 Ft. Lbs
Shock Bolt	3/4"-10	150-175 Ft. Lbs.
Air Spring Bolt (Lower)	1/2"-13	25-35 Ft. Lbs.
Air Spring Nut (Upper)	3/4"-16	45-55 Ft. Lbs.
Brake Dust Shield Bolt	5/16"-18	160-180 In. Lbs.
ABS Bracket Bolt	1/4"-20	75-100 In. Lbs.

Table 1 Recommended Torque Specifications (cont'd)

2. Mechanical Suspension

Description	Size	Torque	
		Ft. Lbs.	N.m
Equalizer Shaft (All Spread) 49" Spread 54"-65-1/2" Spread 72"-109" Spread	1-1/4" Nut	575-625	780-850
	3/4" Capscrew	200-225	270-305
	2-1/2" Nut	300-325	410-445
	1-1/2" Nut	200-225	270-305
U-Bolt Nuts		300-325	410-445
Torque Arm Bolt Nuts	1"	160-200	216-270
Torque Arm Clamping Nuts	1/2"	80	110
	3/4"	175-200	236-270
Spring Retainer Nuts	1/2"	80	110

3. Wheel End Components

Description	Torque Range		Fastener Size
	(lb-ft)	N.m	
1. Hub-cap bolts	10-15	13-20	5/16"
2. Hub fill plug	15-20	20-27	3/8"
3. Adjustment nut - manual bearing adjustment (double nut)	Tighten to 200, loosen, tighten to 50, loosen 1/4 turn and check end play	136	Size depends on axle model and adjustment method.
		68	
4. Jam nut - manual bearing adjustment	250-300	340-408	5/8"
5. Brake mounting bolt	130-165	177-224	
6. Two-piece dust shield bolts (shown)			
• Forged spider	15-20	20-27	3/8"
7. Bolt-on bushing bolts	25-35	34-48	3/8"
8. Cam bushing bolts	25-35	34-48	3/8"
9. Air chamber nuts	80-125	109-170	5/8"

4. Wheel Nut

Stud Size	Wheel Type	Ft-lbs Torque (Dry)	Bolt Size	Ft-lbs Torque (Dry)
3/4" - 16	Disc	450 - 500	5/8" - 11	150 - 175
1-1/8" - 16	Disc	450 - 500	3/4" - 10	210 - 260
	Bud Unimount 10	390 - 440		
	WHD-8	400 - 600		

8.2 KINGPIN AND FIFTH WHEEL PLATE

The kingpin at the front of the trailer is the structural component used to transmit accelerating and decelerating loads into the trailer frame. It must be in good condition to perform as required.

Visually inspect the kingpin as part of the pre-trip inspection, at 5,000 miles (8,000 km) or weekly and annually as part of your normal preventative maintenance program. Be sure the kingpin does not have excessive wear, looseness, chipped out areas, cracks or bent mounting frame. If any kingpin shows such defects, it should be replaced immediately.

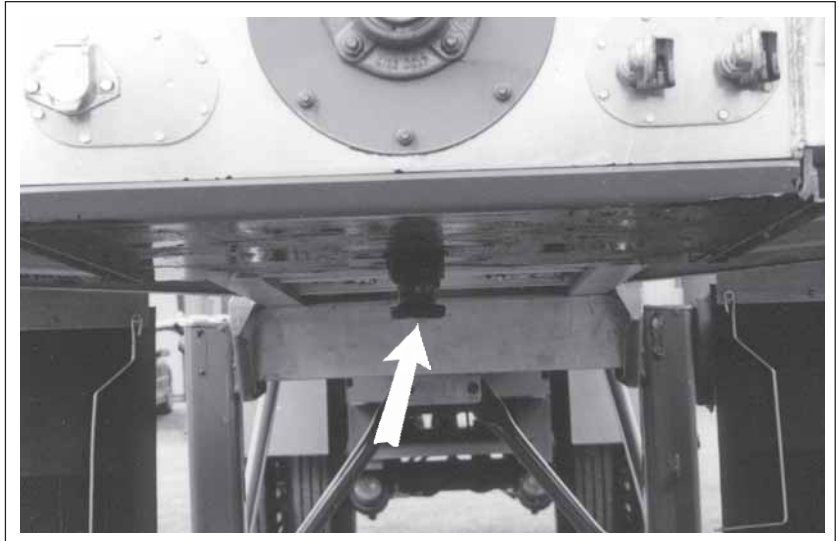

Fig. 8-1 KINGPIN

Visually inspect the frame and structure for bends, cracks or distortions as part of the pre-trip inspection procedure. Thoroughly inspect the structural integrity of the assembly every 25,000 miles (40,000 km) or every three months as part of your preventative maintenance program. Replace the entire assembly if any structural defects are found.

8.3 FIFTH WHEEL

A fifth wheel system is used on the towing tractor to secure the kingpin and carry the weight of the attached trailer. It must be maintained in good condition to perform as intended.

Visually inspect the fifth wheel as part of the pre-trip inspection to check for cracks, bends, chips or distortions of the frame and upper plate.

NOTE

Use a high-pressure washer or steam cleaner to remove all the dirt and grease from the fifth wheel assembly prior to each weekly inspection. Apply a fresh coat of grease to the fifth wheel assembly prior to hooking-up the trailer.



Fig. 8-2 FIFTH WHEEL

Clean the assembly every 5,000 miles (8,000 km) or bi-monthly and annually to perform a thorough inspection. Check the frame and upper plate for cracks, bends, chips or distortions.

When the components are clean, check that the lock closes completely around the kingpin.

To adjust the lock:

1. Obtain a Holland kingpin lock tester and place in the throat of the lock. Close the lock.
2. The jaws should be snug around the tester but not binding.
3. Use the adjusting nut on the front edge of the fifth wheel to set the clearance of the jaws.
4. Use a light oil to lubricate all moving parts prior to returning to service.

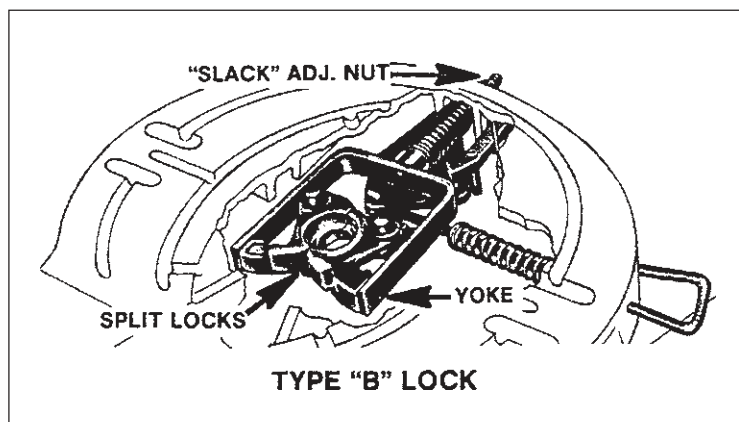

Fig. 8-3 KINGPIN LOCK

8.4 AXLE ALIGNMENT

A standard axle is used as the main transverse structural member to transmit loads between the trailer frame and the surface contacting components. All running gear components are attached to or form part of the axle assembly.

Although there is very little that can go wrong with the axle itself, loose, bent or damaged attaching components can cause the axle to go out of alignment. This misalignment will be found during the regularly scheduled 25,000 mile inspection. However, axle misalignment shows itself most commonly by accelerated tire wear and dogtracking by the trailer. Visually check the tire wear when checking air pressure. The driver should identify these handling characteristics to service personnel for correction.

To check axle alignment, follow this procedure:

1. Select a working area that is level, with a compacted surface and is large enough to provide access from all sides.
2. Move the trailer forward and backward several times to remove any binding from the components.
3. Stop the trailer when moving in the forward direction without using trailer brakes. This will give the components a forward bias with no binding.
4. Unhook the trailer and support on the landing gear at the normal height or parallel to the ground.
5. Install a commercially available axle extender on each axle or remove the wheels to prevent any components from interfering with the measurements.

8.4 AXLE ALIGNMENT (cont'd)

6. Attach an S hook to a steel tape and measure the distance between the kingpin and the end of each axle. Dimensions A and B should be equal within $\pm 1/8$ inch (0.125 in) (3.1 mm).
7. Adjust the suspension mounting system as required to set dimension A and B within $1/8$ inch (0.125 in) (3.1 mm). Refer to suspension system instruction brochure for detailed adjustment procedure.

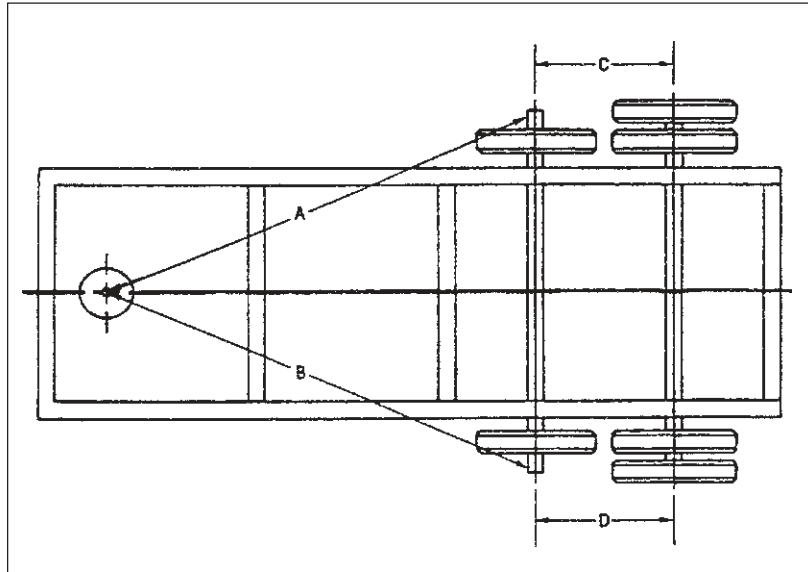

Fig. 8-4 AXLE DIMENSIONS

8. Use a trammel bar to measure the road and curbside dimensions between the first and second axles. Dimensions C and D should be within $1/16$ inch (0.0625 in) (1.6 mm).

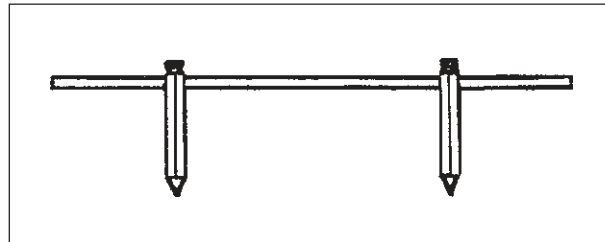

Fig. 8-5 TRAMMEL BAR

9. Adjust the suspension system as required to set this dimension to its recommended tolerance.
10. Repeat measuring and adjustment procedure on the third axle if so equipped.
11. Tighten all fasteners to their specified torque. Do not allow any suspension system or running gear fasteners to loosen.

IMPORTANT

Always use a torque wrench when tightening fasteners. The correct torque on a fastener provides the proper clamping force on the adjacent components and they will perform as expected.

12. The front axle must be aligned to the kingpin with second and third axles adjusted to the front axle.
13. Always check axle alignment after repairing the suspension system.

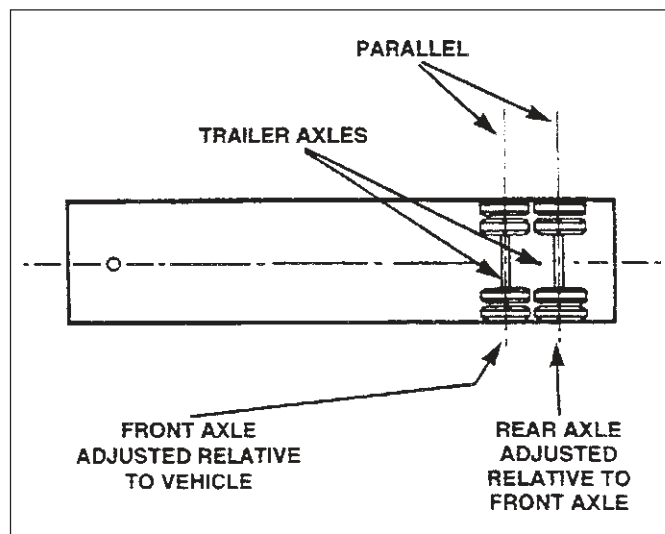

Fig. 8-6 ALIGNED

8.5 WHEEL HUBS/BEARINGS

Some axles use an oil bath design for lubricating wheel bearings. It is a virtual zero maintenance system providing that the oil remains in the hub.

Visually check the hub every day for leaks when checking tire pressure during pre-trip, daily, refueling, or rest stop inspections. If oil leaks are detected on any hub, repair the leak and refill the hub before proceeding.

A. Oil Leaks:

Visually inspect the hub for leaks every time the tire pressures are checked. Leaks will normally be visible as dust collects on the escaping oil. Stop and correct the leak immediately to prevent running the hub low on oil. Running low or without oil will quickly overheat the hub and cause the bearings to seize. Change the oil in the hub when installing new seals to correct a leak.

B. Oil Level:

1. Check the oil level in each wheel hub every 5,000 miles (8,000 km) or weekly and whenever an oil leak is found. Clean the end plate of the hub to remove the dust, dirt or mud build-up.

The oil should be visible to the top of the outer concentric circle of the end cap. Add oil as required through the fill plug in the hub. Always use clean oil and prevent contaminants from entering the hub when adding or changing oil.

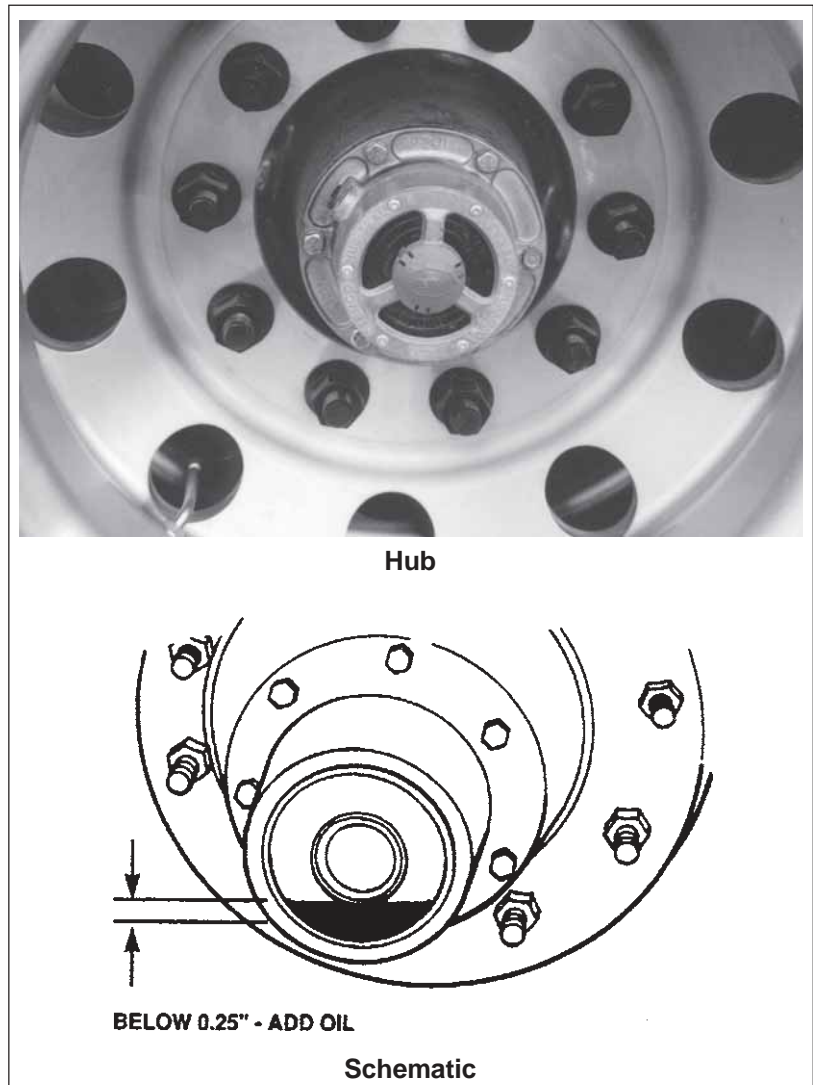

Fig. 8-7 OIL LEVEL

2. Change the oil every 100,000 miles (160,000 km), annually or whenever the axle nuts are retorqued or the brakes are relined. The hub cavities must be opened when retorquing axle nuts and changing oil should be done as part of the procedure.

8.5 WHEEL HUBS/BEARINGS (cont'd)

C. Wheel Bearings:

Wheel bearings carry and transmit the load between the wheels and the axles. In addition to proper lubrication, the bearings must have the recommended end play to perform as expected. Bearing end play is set and controlled by the torque of the axle nuts on the end of each spindle. Each hub must seat securely on its bearings to prevent wobble or slop in the system. Turning the wheel or wobbling it indicates the condition and tightness of the hub/bearing assembly.

1. Turning/Wobble:

- a. Park the trailer on a level, hard surface and release the brakes.

- b. Place chocks in front of and behind each wheel.

- c. Jack each axle up until the tire clears the ground.

- d. Support the axle on a safety stand to prevent slipping or tipping.

- e. Turning the wheel slowly to check the condition of the bearings and to determine if the brakes are dragging.

- f. **Dragging Brakes:** Can



Fig. 8-8 WHEELS

- g. **Bearing Condition:** Can be felt as the wheel turns. Bearings in good condition turn easily and smoothly. Bearings in poor or bad condition can be felt through the wheels as scraping, grinding, dragging or bumps. Replace bearings before resuming work.

- h. **Wobble:** Grasp each side of the

wheel or tire and wiggle the wheel and assembly. If the wheel or hub wobble on the spindle, the bearings have lost their end play and the axle nuts require tightening.

NOTE

If the bearings are not in good condition, replace them before setting the end play.

8.5 WHEEL HUBS/BEARINGS (cont'd)

C. Wheel Bearings (cont'd):

2. Bearing End Play:

- a. Place a pan under the hub drain plug.
- b. Remove the drain plug from the hub and drain the oil.
- c. Remove the hub end plate and lay to the side.
- d. Remove the set screw from the jam nut.
- e. Remove the jam nut and perforated lock washer from the spindle.
- f. Use a torque wrench to tighten the adjusting nut 200 ft-lbs. (136 N.m) while rotating the wheel assembly in both directions.
- g. Back the adjusting nut off to zero torque.
- h. Retorque the adjusting nut again to 50 ft-lbs (68 N.m) of torque while rotating the wheel assembly in both directions.
- i. Loosen the nut 1/4 turn.
- j. Install the perforated lock washer. Be sure the adjusting nut pin aligns with the hole in the lock washer. Turn washer over and/or adjusting parts as required.
- k. Install jam nut and tighten to 250-300 ft-lbs. (340-408 N.m).

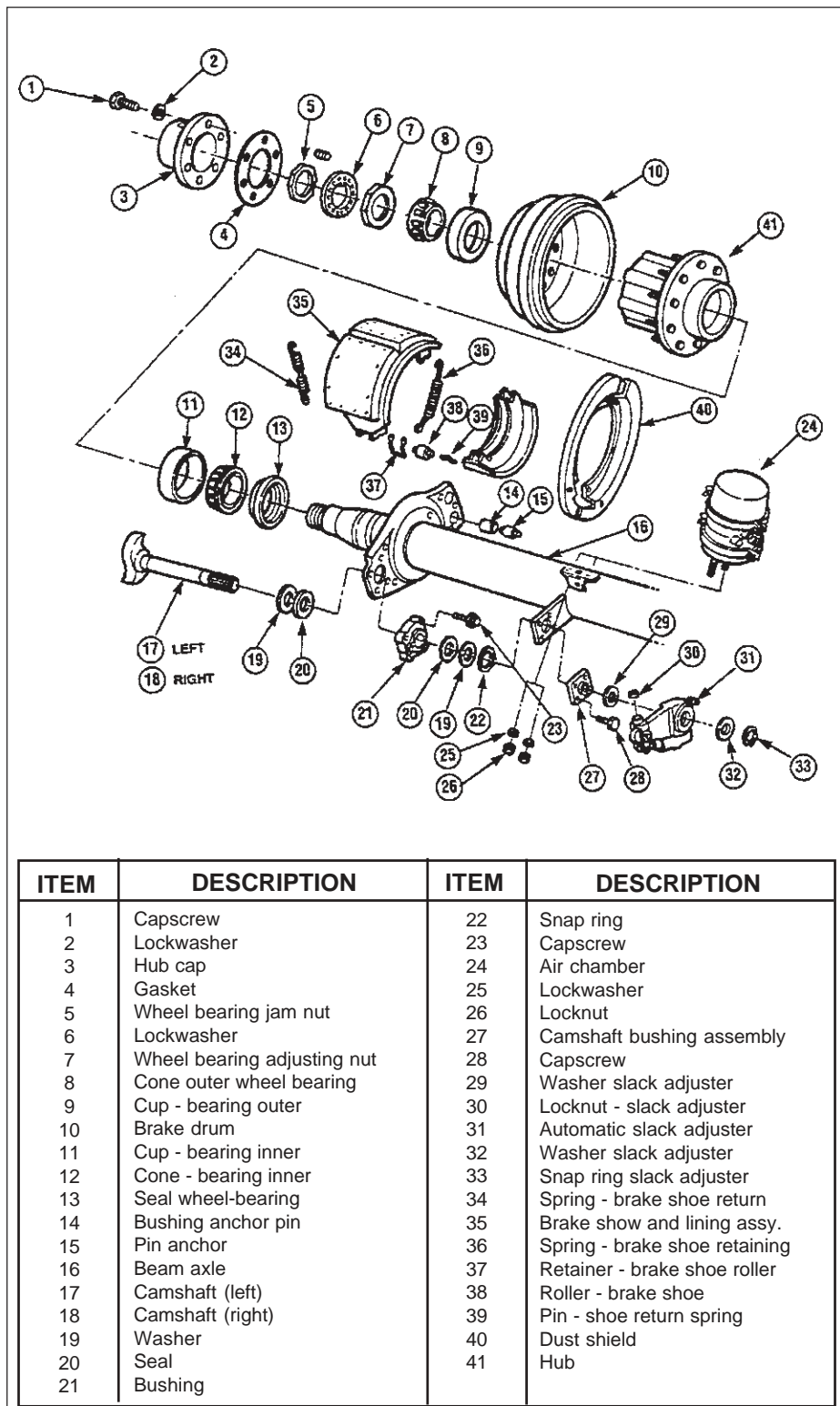

ITEM	DESCRIPTION	ITEM	DESCRIPTION
1	Capscrew	22	Snap ring
2	Lockwasher	23	Capscrew
3	Hub cap	24	Air chamber
4	Gasket	25	Lockwasher
5	Wheel bearing jam nut	26	Locknut
6	Lockwasher	27	Camshaft bushing assembly
7	Wheel bearing adjusting nut	28	Capscrew
8	Cone outer wheel bearing	29	Washer slack adjuster
9	Cup - bearing outer	30	Locknut - slack adjuster
10	Brake drum	31	Automatic slack adjuster
11	Cup - bearing inner	32	Washer slack adjuster
12	Cone - bearing inner	33	Snap ring slack adjuster
13	Seal wheel-bearing	34	Spring - brake shoe return
14	Bushing anchor pin	35	Brake show and lining assy.
15	Pin anchor	36	Spring - brake shoe retaining
16	Beam axle	37	Retainer - brake shoe roller
17	Camshaft (left)	38	Roller - brake shoe
18	Camshaft (right)	39	Pin - shoe return spring
19	Washer	40	Dust shield
20	Seal	41	Hub
21	Bushing		

Fig. 8-9 SPINDLE COMPONENTS

8.5 WHEEL HUBS/BEARINGS (cont'd)

- I. Check bearing end play by:
 - i. Attaching a magnetic base dial gauge indicator to the end of the spindle.
 - ii. Push the wheel in while rotating the wheel slightly until the dial gauge reading doesn't change.
 - iii. Zero dial gauge.
 - iv. Pull wheel assembly out while rotating wheel slightly until dial reading doesn't change.
 - v. Dial indicator will read bearing end play.
 - vi. If end play does not register between .001-.005 inches (0.025-.125 mm), readjust end play.
 - vii. Replace components if readjusting does not give end play tolerance within specs.

- m. Install a new gasket on hub face cap.
- n. Install hub face cap and tighten mounting cap screws to their specified torque.
- o. Add the specified amount of oil to the hub and secure fill plug. Check for leaks. Correct leaks before resuming operation.

- p. Remove safety stand from under axle and lower wheel to the ground.

- q. Repeat checks on all other axles.

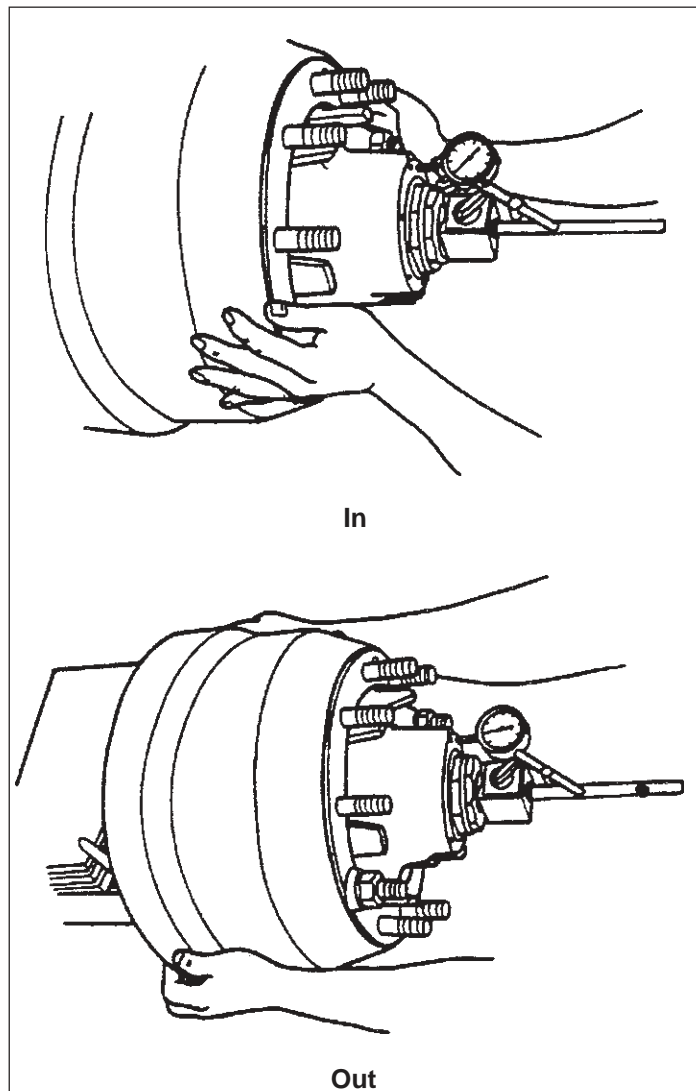

Fig. 8-10 DIAL INDICATOR

8.6 WHEELS

A variety of steel or aluminum wheels can be used on the trailer depending on customer preference or application requirements. Wheels must be maintained in good condition and all fasteners tightened to their specified torque level to obtain the expected life and performance.

Loose fasteners are the most common cause of wheel problems on a trailer. Always retorque the wheel fasteners per the break-in schedule of 100, 500, 1500 and 5,000 miles (160, 800, 2500 and 8000 km) when the unit is new and after a wheel has been removed. Always use an accurate calibrated torque wrench when tightening fasteners. A loose fastener is defined as one that is not tightened to its specified torque. A loose fastener does not provide the required clamping, anchoring or holding forces to stabilize the adjacent components. Insufficient clamping forces can lead to flexing, bending, cracking, hole elongation or other component deterioration that cause failures and/or accidents. Always keep fasteners tightened to their specified torque. Over-torquing can overload certain components, causing compression cracks and strip nuts or studs. Over-torquing fasteners can be as detrimental as under-torquing. Always tighten fasteners to their specified torque.

Use an accurate torque wrench to retorque wheel fasteners every 10,000 miles (15,000 km) or monthly whichever comes first. Always retorque wheels per the break-in schedule whenever a wheel is removed and remounted.

Always follow the recommended mounting procedure when installing wheels to the trailer.

1. Disc Wheels (Stud Pilot Style):

- a. Mount single or inner dual wheel on hub. Be careful not to damage the threads on any of the studs.
- b. Snug the nuts up in the alternating sequence shown to center it on the hub and insure an even contact between the wheel and hub.

- c. Tighten nuts to their specified torque using

IMPORTANT

Left-hand threads are used on the left side of the vehicle. Right-hand threads on right.

the same alternating sequence.

- d. Mount outer dual. Do not damage the threads when sliding the wheel over the studs.
- e. Snug up the nuts in the alternating sequence shown to center it on the hub and to provide even contact.
- f. Tighten the outer wheel nuts to their specified torque.

IMPORTANT

When retorquing inner nuts of double nut design, always back off outer nut several turns, then retorque them.

Table 2 Recommended Wheel Stud Torque (Disc Wheels)

Stud Size	Wheel Type	Ft-lbs Torque (Dry)
3/4"-16	Disc	450 - 500
1-1/8"-16	Disc	450 - 500
15/16-12	Disc	750 - 900
1-5/16-12	Disc	750 - 900
	Bud Unimount 10	390 - 440
	WHD-8	400 - 600

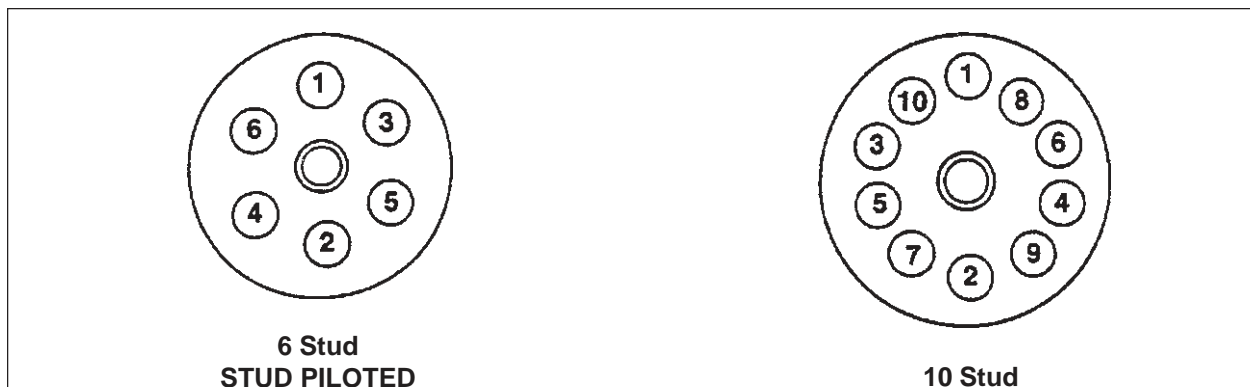

Fig. 8-11 NUT TORQUE SEQUENCE

2. **Hub Piloted Wheels:**

- a. Mount inner wheel on the hub.
- b. Slide on the hub guide until the wheel is snug against the hub. Be careful not to damage the threads on any of the studs.
- c. Mount outer dual wheel on the hub and snug up against the inner wheel.

NOTE

Add a drop or 2 of oil on the end of the bolt, threads and the nuts and flanges.

- d. Install nuts and tighten in alternate sequence shown.

Table 3 Recommended Wheel Bolt Torque

Stud Size	Ft-lbs Torque (Oiled)
M22 x 1.5 (33 mm or 1-1/2 Hex)	450 - 500
M20 x 1.5 (30 mm Hex)	280 - 330

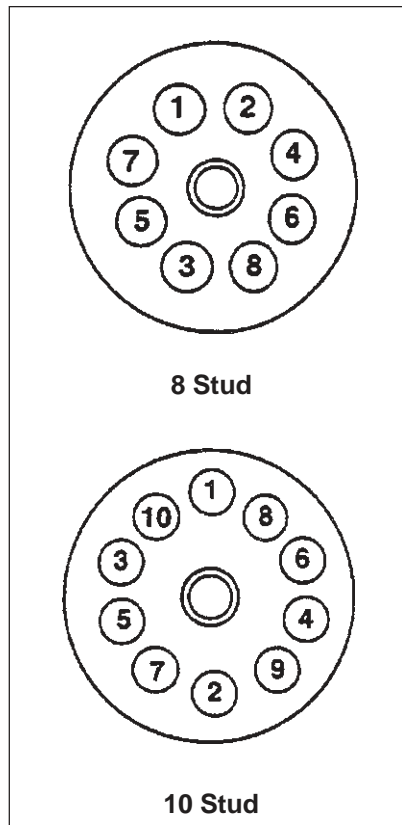

Fig. 8-12 HUB PILOTED

3. **Rim/Wheel (Cast Spoke):**

- a. Inspect and clean all the parts. Replace any damaged components.
- b. Place rims and spacer band on wheel. Be sure to space valve stem between spokes.
- c. Secure clamps evenly in position.
- d. Snug up the nuts in the alternating sequence shown to allow the inside rim to seat itself on the mounting bevel and avoid wheel wobble.
- e. Tighten the nuts evenly in small increments in the shown alternating sequence until all nuts are tightened to their specified torque.
- f. Check for runout and redo if necessary.

Table 4 Recommended Wheel Bolt Torque (Spoke Wheels)

Bolt Size	Ft-lbs Torque (Dry)
5/8" - 11	150 - 175
3/4" - 10	210 - 260

IMPORTANT

Do not over-torque fasteners. Over-torquing can strip threads, collapse spacers or lead to other problems that cause loose fasteners. Use an accurate torque wrench when tightening fasteners.

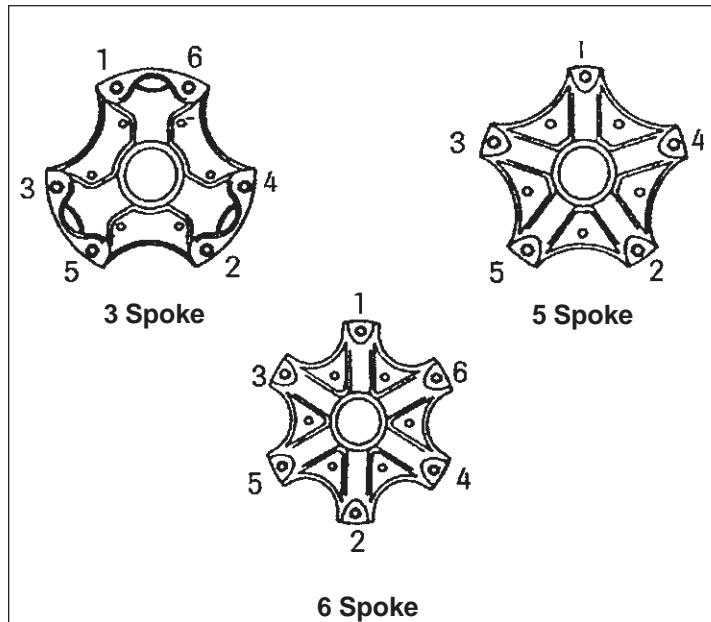

Fig. 8-13 RIM/WHEEL TORQUE SEQUENCE

8.7 TIRES

Tires are one of the most important components on a trailer and must be maintained in top condition to obtain their desired load carrying capacity and durability. Tire wear rate can be used as an indicator of the condition of the axle alignment or suspension system. Poorly maintained tires will wear rapidly or deteriorate and fail quickly and suddenly. A poorly maintained tire can and will affect adjacent components leading to their potential failure as well.

Proper tire maintenance includes but is not limited to:

1. Inflation Pressure:

Operating at an incorrect inflation pressure is the most common maintenance problem with tires. Tires should be checked frequently to be sure they are at their specified pressure.

It is recommended that tire pressure be checked at the start of each working day and at least one other time during the day. Always use an accurate hand gauge when checking the pressure and check each tire. Carry it with your unit so it is always available when needed. Best time to take tire pressure is when tire is cold. Every tire has its specified operating pressure molded into the sidewall. Adjust the pressure as required to obtain the specified inflation pressure when the tire is cold.

Tire pressure will normally increase 10 to 15 psi during operation as the tire heats up. If the pressure exceeds this normal increase, it indicates the tire may be overloaded, underinflated, driven too fast, improperly sized or a combination of these factors. Identify the cause of the problem and correct it before resuming work.

a. Underinflation:

Operating at lower than the specified pressure is a tire's worst enemy. Use an accurate tire pressure gauge to check the pressure at the start of each working day, every few hours during the day and/or whenever the handling characteristics change suddenly. Underinflation will increase tread wear and cause a deterioration of the tire body leading to a separation of the tread from the body. An underinflated tire is soft and deflects more than it should causing fatigue cracks or breaks in the body cord construction leading to sudden air loss.

Operation with a low or flat tire on a dual will generate a lot of heat in the underinflated tire from internal friction that it can and will disintegrate or catch on fire. It also causes overloading of the adjacent tire on the axle or axles and could lead to their failure also.

b. Overinflation:

Inflating a tire over its specified pressure can lead to serious problems also. Overinflation creates a more rigid tire that does not absorb road shocks as well as it should. Shock loading from impacting bumps or pot holes can break the fabric of the tire and/or transmit the higher loads into the rim, wheel and adjacent components causing them to fail as well. Overinflated tires cut, snag or puncture more easily than properly inflated tires. Also overinflating tire will not increase its load carrying capacity.

8.7 TIRES (cont'd)

2. Tire Matching and Spacing on Duals

Tires on a dual assembly must be matched for size (diameter or rolling radius) and type of construction to obtain the desired and expected performance and life.

a. Matching of Size:

Tire sizes can vary between manufacturers and as they wear. Special care must be taken to be sure the tire size (rolling radius, diameter or circumference) is within the following dimensions:

Rolling radius: 1/8 inch (3 mm)

Diameter: 1/4 inch (6 mm)

Circumference: 3/4 inch (19 mm)

Measure the tire when it is mounted, inflated to its specified pressure and not loaded. The easiest method is to use a steel tape to measure the circumference of the tire.

Unequal sized tires will require the larger tire to carry more of the load and potentially overload it. Overloading accelerates the wear and can lead to tire failure. When the one tire fails, the remaining tire or tires will then also be overloaded. The smaller tire will not contact the road surface properly and will wear in an irregular manner giving poor durability.

b. Tire Construction:

Customers can use radial or bias ply tires on their trailer. However, it is recommended that different types of tires not be mixed on an axle. Each type of tire has different deflection, cornering and spring characteristics. These differing characteristics cause the tires to always fight each other during operation and will give erratic handling and poor wear characteristics when mounted on the same axle. Different types can be mounted on different axles but not on the same axle.

c. Tire Spacing:

A wide variety of rims can be used on the trailer and each will provide a different offset. Select the rims to provide sufficient space and clearance between the sidewalls of the tires. Normally there should be at least 2 inches (50 mm) and 3 inches (75 mm) between the sidewall of a bias ply and radial dual tire assembly respectively. This spacing will provide sufficient clearance for each type of tire to deflect as they rotate and when they impact a pothole or bump in the road. If they touch during operation, they will wear or abrade at the contact point. In addition, tires that are too close do not shed dirt, trash or stones that can get between them during operation as well as properly spaced tires.

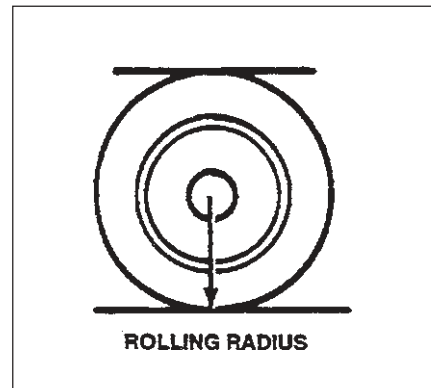

Fig. 8-14 TIRE DIMENSIONS

8.8 BRAKES

All components in the brake system must be maintained in good condition for the system to perform at top efficiency. It is recommended that brakes and associated components be checked, serviced and maintained per the Trailer Preventative Maintenance Schedule (TPM) for the trailer. In this section, the basic brake disassembly and assembly procedure will be covered. Refer to the axle manufacturers service manual for a more detailed repair and rebuilding procedure.

Check brakes frequently to keep them in top condition. Poorly maintained brakes will not stop the trailer as effectively as well-maintained brakes and in the extreme could fail completely leaving no brakes or no ability to stop the unit.

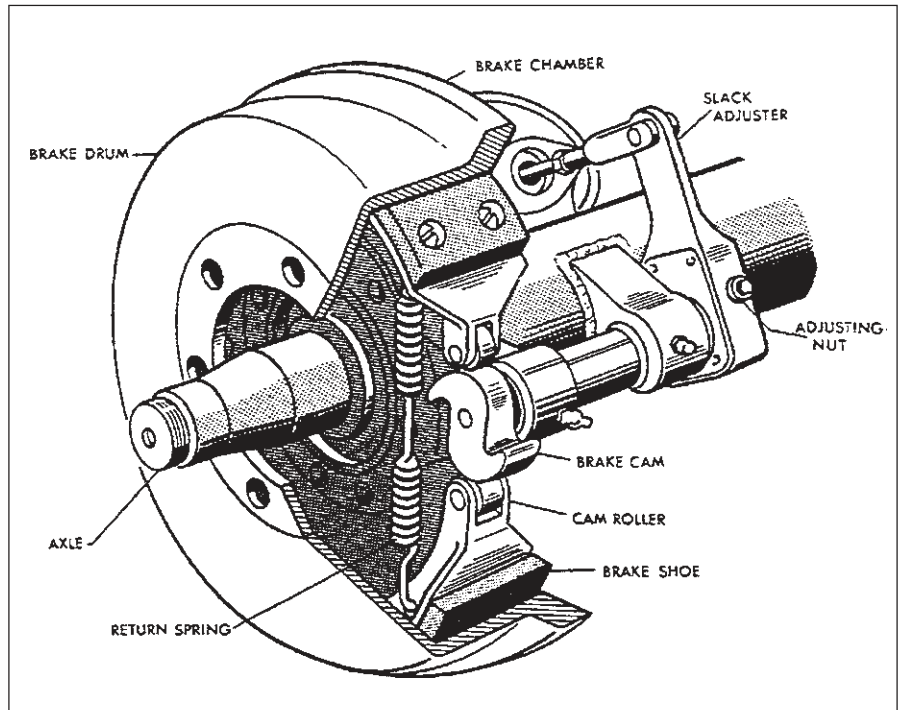

Fig. 8-15 BRAKE SYSTEM

It is recommended that the driver checks the brakes at least once during each working day when checking tire pressure and performing a quick visual of the unit. Use your hand to check the temperature of the drum. All drums should be approximately the same temperature if the system is functioning properly. If any drum is significantly warmer or colder than the rest, it indicates a problem. Determine the cause of the problem and correct it before resuming work. By discovering and correcting it while it is minor, major repair, expense and down time can be prevented.

At 25,000 miles (40,000 km) or every 3 months when the axle is raised off the ground for the complete wheel end inspection, check the brakes at the same time. When the wheels are turned by hand, the wheel end should decrease speed slowly. If it does not, the brakes could be dragging or there could be a problem with the bearings. Dragging brakes will also be detected by hot drums during the daily drum temperature checks. Adjust the brakes to correct the problem.

Remove the brake dust covers (if so equipped) to access the shoes. Check the thickness of the linings. Reline or replace shoes when the lining thickness is less than 1/8 inch (3 mm). Uneven wear among the brake shoes on a trailer indicate that the braking system has not been set or maintained properly causing uneven application and wear. If uneven lining wear appears, reset the system to provide even application of all the shoes. Do not operate when the linings are less than 1/8 mile (3 mm) to prevent the lining anchor rivet or bolts from contacting the drum. Head contact with the drum will cut grooves in the surface and require extra machining to remove them when rebuilding the brakes.

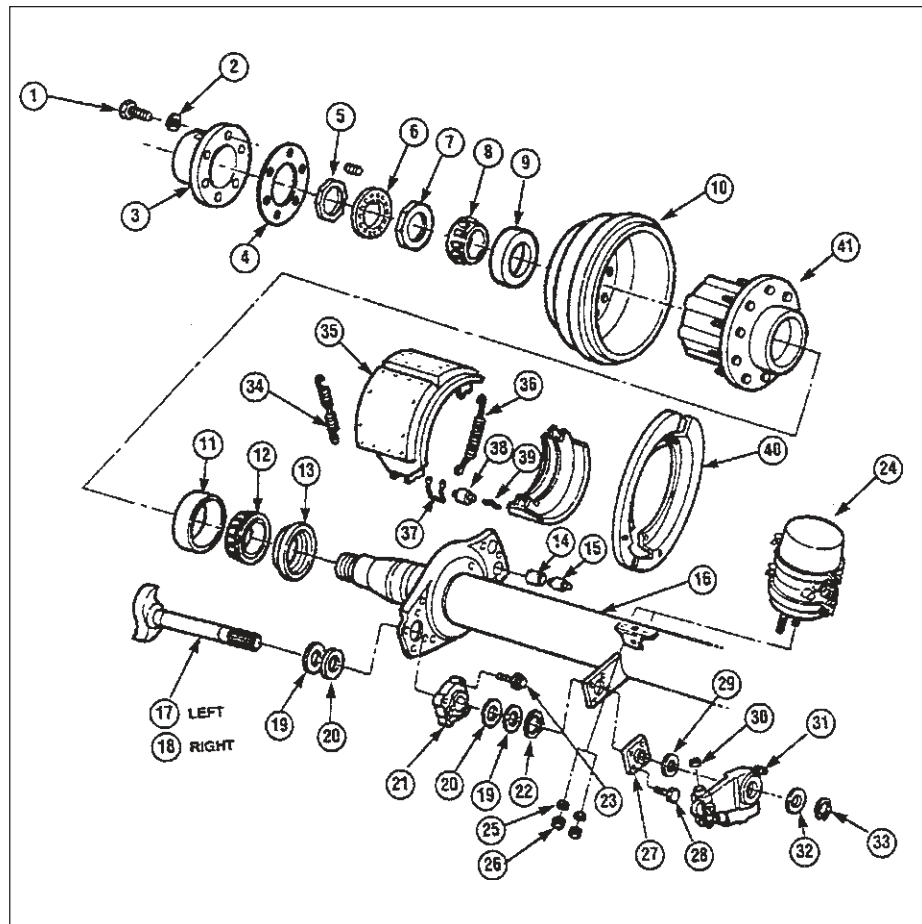

Fig. 8-16 EXPLODED VIEW

Several types of friction material are available for use on the brake shoes. Each has its own friction coefficient and braking characteristics. Select the one that best fits your application but do not mix materials on the same trailer. Differing materials require different application forces to obtain the same braking force and a braking system can only apply one force when it is properly set.

Recent changes in environmental laws have banned the use of asbestos including brake linings. Always use the appropriate safety gear when removing brake shoes containing asbestos from your trailer. Replace the shoes that are equipped with approved material.

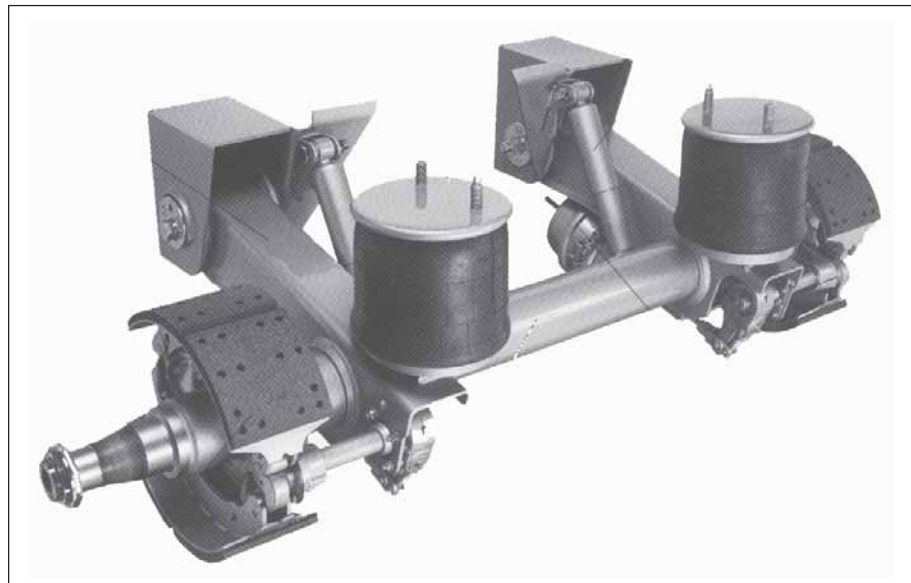

Fig. 8-17 AXLE

A. Removing Brakes:

1. Position the trailer on a level hard surface.
2. Exhaust all the air from the air system.
3. Jack the axle up and place on safety stands.
4. Remove the wheel assembly from the axle.
5. Release the slack adjuster (Refer to Section 8.6).
6. Disable or cage spring brakes if so equipped.
7. Drain oil from hub and remove spindle end components.
8. Remove the hub and drum assembly. Support with a hoist as the assembly slides off the spindle. Use a puller if required.
9. Remove roller retaining clip from the bottom and top brake shoe cam rollers.
10. Disconnect and remove bottom shoe return spring.
11. Rotate bottom shoe to remove retaining springs.
12. Lift top shoe to remove.
13. Disconnect push rod from slack adjuster.
14. Back off and remove slack adjuster.
15. Remove cam shaft.

B. Installing Brakes:

1. Inspect all the components. Replace any that are cracked, bent or worn.
2. Lubricate the camshaft spline, slack adjuster gear and slack adjuster pins with anti-seize compound.
3. Install cam shaft and slack adjuster. Secure with snap rings.
4. Adjust slack adjuster to its required angle and attach to the push rod. Release slack adjuster pawl if so equipped.
5. Use a good quality brake grease to lubricate the anchor pins and rollers where they contact the brake shoes.
6. Place the upper shoe in position.
7. Place the lower shoe in position and attach 2 new retaining springs.
8. Rotate lower shoe forward and attach new brake shoe return spring.
9. Install both cam rollers and secure with retainers.
10. Install and secure the remaining wheel and components.
11. Repeat with other wheel ends as required.
12. Tighten all fasteners to their specified torque.

Manual Bearing Adjustment

- a. Tighten to 200 ft-lbs.
- b. Completely loosen.
- c. Tighten to 50 ft-lbs.
- d. Loosen 1/4 turn

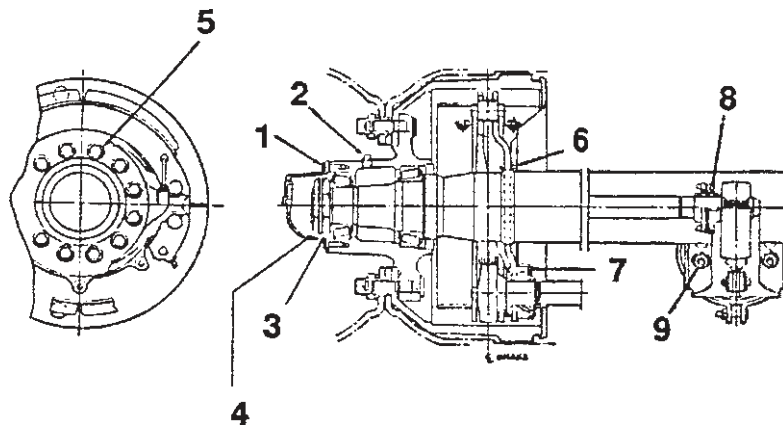

Description	Torque Range		Fastener Size
	(lb-ft)	N.m	
1. Hub-cap bolts	10-15	13-20	5/16"
2. Hub fill plug	15-20	20-27	3/8"
3. Adjustment nut - manual bearing adjustment (double nut)	Tighten to 200, loosen, tighten to 50, loosen 1/4 turn	136 68	Size depends on axle model and adjustment method.
4. Jam nut - manual bearing adjustment	250-300	340-408	
5. Brake mounting bolt	130-165	177-224	5/8"
6. Two-piece dust shield bolts (shown)			
• Forged spider	15-20	20-27	3/8"
7. Bolt-on bushing bolts	25-35	34-48	3/8"
8. Cam bushing bolts	25-35	34-48	3/8"
9. Air chamber nuts	80-125	109-170	5/8"

Fig. 8-18 BRAKE/WHEEL END COMPONENTS

8.9 SLACK ADJUSTERS

8.9.1 ROCKWELL AUTOMATIC SLACK ADJUSTER

1. The air chamber push rod extends beyond its pre-determined optimum stroke length, the change in geometry between the chamber pushrod and slack lever arm raises the slack adjuster actuator rod.
2. The piston contacts the retaining ring and lifts the actuator.
3. If adjustment is required, the spiral serrations on the actuator are lifted over the serrations on the pawl.
4. When the push rod retracts, it forces the actuator downward into the pawl serrations and the actuator rotates.
5. As the actuator rotates downward, it turns the worn gear that turns the gear/spline/camshaft to maintain the brake adjustment.
6. Pull the pawl out and block in the out position when disassembling the brake system.
7. Use the bottom nut to turn and adjust the gear position.



Installed

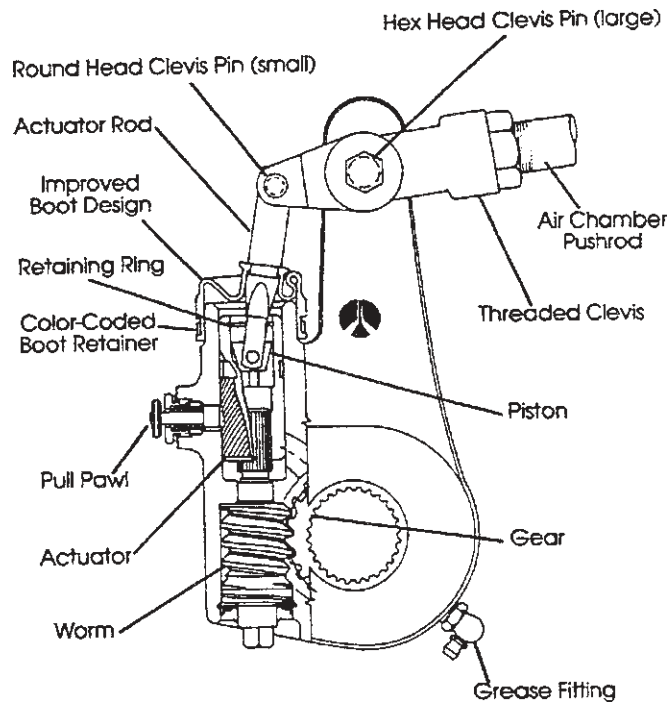

Schematic

Fig. 8-19 ROCKWELL SLACK ADJUSTER (TYPICAL)

8.9 SLACK ADJUSTERS (cont'd)

8.9.2 MANUAL AND AUTOMATIC SLACK ADJUSTER MAINTENANCE

In an S-cam type foundation brake, the final link between the pneumatic system and the foundation brake is the slack adjuster. The arm of the slack adjuster is fastened to the push rod of the chamber with a clevis and the spline end is installed on the brake camshaft.

Primarily, the slack adjuster is a lever that converts the linear force of the air chamber push rod into a torque which turns the brake camshaft and applies the brakes.

Two types of slack adjusters are in use: manual type slack adjusters, which periodically require a manual adjustment and automatic slack adjusters which will automatically adjust during normal service braking applications. All slack adjusters utilize the worm and gear principle and fundamentally differ only in their torque limit specification.

MANUAL SLACK ADJUSTERS

Manual slack adjusters contain four basic components: the body, worm gear, worm shaft, and locking screw or collar. See Fig. 8-20.

The worm shaft of a slack adjuster incorporates an external adjusting hex. Turning the adjusting hex rotates the worm shaft which turns the worm gear and brake cam shaft, thus spreading the brake shoes and reducing drum-to-lining clearance.

Higher torque-rated slack adjusters use the lock ball or plunger and worm shaft indent principle adjustment lock. The lock ball or plunger must engage the worm shaft indent after the adjustment is completed. An audible metallic click can be heard when engagement is made.

IMPORTANT

Manual and automatic slack adjusters are for brake adjustment and will not compensate for faulty foundation brakes.

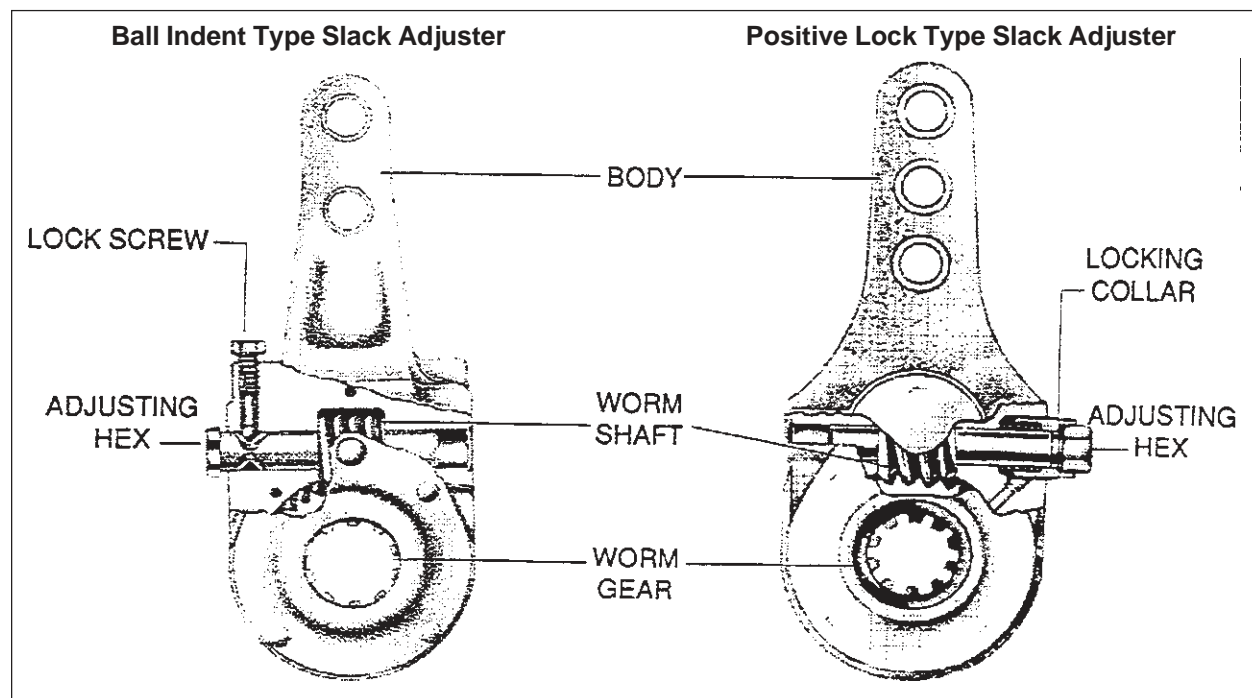

Fig. 8-20 MANUAL SLACK ADJUSTERS

8.9 SLACK ADJUSTERS (cont'd)

8.9.2 MANUAL AND AUTOMATIC SLACK ADJUSTER MAINTENANCE (cont'd)

AUTOMATIC SLACK ADJUSTERS

While automatic slack adjuster designs vary in the manner in which they are installed and operate, all are designed to automatically maintain a predetermined shoe-to-drum clearance or brake chamber stroke. Some automatic slack adjusters adjust upon the brake application stroke, others adjust upon release. Automatic slack adjusters can greatly reduce manual adjustments. **Automatic slack adjusters do not reduce the need for periodic maintenance.**

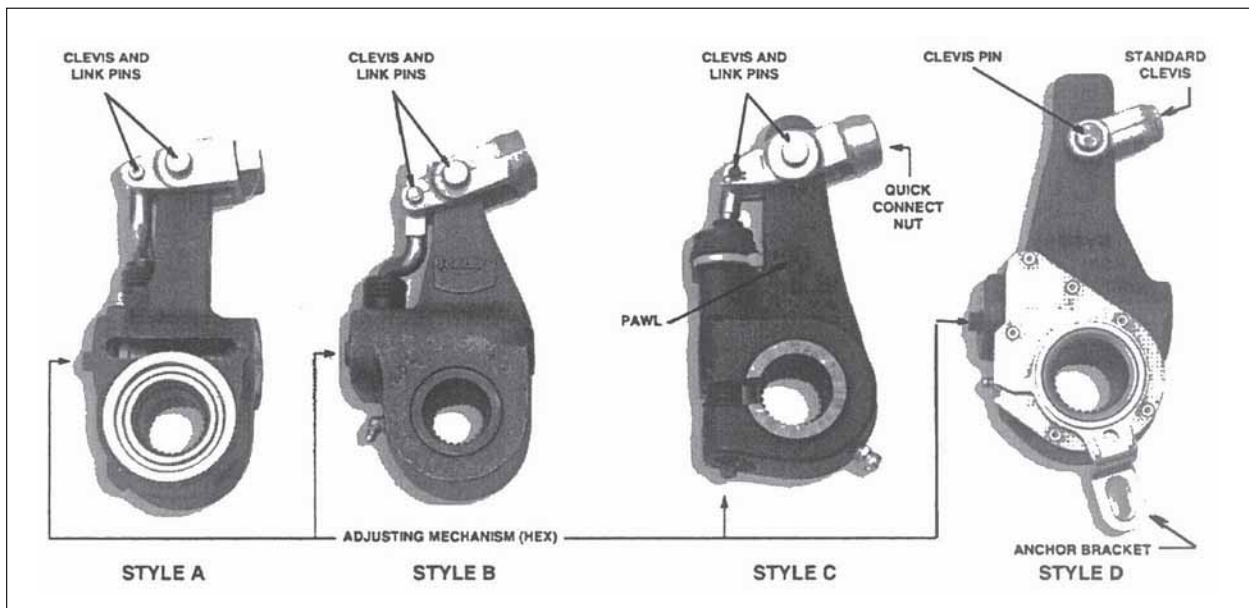

Fig. 8-21 AUTOMATIC SLACK ADJUSTERS

8.9 SLACK ADJUSTERS (cont'd)

8.9.2 MANUAL AND AUTOMATIC SLACK ADJUSTER MAINTENANCE (cont'd)

BRAKE ADJUSTMENT PROCEDURE

NOTE

All adjustments should be made with cold brake drums and the brakes fully released.

A. Manual Slack Adjuster Brake Adjustment Procedure

1. Slack adjusters with locking collar (positive lock type):

Jack up the vehicle. Thoroughly clean the adjusting hex and locking sleeve area. Position a wrench or socket over the adjusting hex and disengage the locking sleeve by depressing it. With the locking sleeve fully depressed, adjust the brakes while rotating the tire and wheel. Use the wrench or socket to turn the adjusting hex until the shoes contact the drum. Then back off the adjusting hex until the tire and wheel turn freely. The actuator stroke should be as short as possible without the brakes dragging.

If the vehicle cannot be jacked up, thoroughly clean the adjusting hex and locking sleeve area. Position a wrench or socket over the adjusting hex and disengage the locking sleeve by depressing it. With the locking sleeve fully depressed, use the wrench or socket to turn the adjusting hex until it will go no further indicating that either the shoes have contacted the drum or the adjusting hex has been turned in the wrong direction. Pull on the slack adjuster to make sure it will not move. If there is movement, adjustment was made in the wrong direction and the adjusting hex must be turned in the opposite direction until it will go no further. After establishing solid shoe-to-drum



WARNING

To avoid possible injury, proper precautions must be taken to prevent automatic actuation of the brake chambers while adjusting slack adjusters. Always block the wheels or mechanically secure the vehicle. Spring brakes must be mechanically caged or released with air. All brakes should be released.

contact, back off the adjusting hex 1/4 turn for worn linings and 1/2 turn when relining brakes. The actuator stroke should be as short as possible without the brakes dragging. Measure the chamber power stroke at 80-90 psi as described in subsection "B", "Automatic Slack Adjuster Brake Adjustment Procedure," below. Take a free stroke measurement as outlined in the section entitled FAILURE ANALYSIS. Make sure you have at least 3/8" of free stroke. Free strokes less than 3/8" can cause brake drag. If you cannot maintain the maximum legal stroke and the free stroke is less than 3/8", contact the brake manufacturer for foundation or brake geometry problems.



CAUTION

When the manual slack adjuster brake adjustment is completed, the adjusting hex should be positioned so the locking sleeve engages it, thus locking it in place. If the locking sleeve does not engage the adjusting hex, the slack adjuster can back itself off.

8.9 SLACK ADJUSTERS (cont'd)

8.9.2 MANUAL AND AUTOMATIC SLACK ADJUSTER MAINTENANCE (cont'd)

2. **Slack adjuster with lock screw ball indent type lock mechanism:**
Back off (turn counter-clockwise) the worm shaft lock screw (if applicable). Make the necessary adjustment by turning the adjusting hex as described in item number 1, directly above. Following brake adjustment, make certain that the lock ball or plunger engages the worm shaft indent. Without such engagement, the slack adjuster can back itself off.

Table 5 Chamber Type vs. Maximum Legal Stroke at 80 PSI Brake Application Pressure

Chamber Type	Maximum Legal Stroke
12	Less than 1-3/8"
16	Less than 1-3/4"
20	Less than 1-3/4"
24	Less than 1-3/4"
24 Long Stroke	Less than 2.0"
30	Less than 2.0"
36	Less than 2-1/4"

B. Automatic Slack Adjuster Brake Adjustment Procedure

An automatic slack adjuster should not have to be manually adjusted except for initial installation and at brake reline. Instead of manually adjusting the slack, the following procedure should be followed during inspection:

Chamber Power Stroke:

A power stroke at 80-90 psi brake application pressure will check both adjustment and foundation brake condition. Perform the following:

1. Measure the brake chamber face to the center of the clevis pin at all wheel locations (see Fig. 8-22).
2. Make brake applications until the air reservoir gauge reads 90-100 psi. Then have an assistant make a full brake application and hold it.

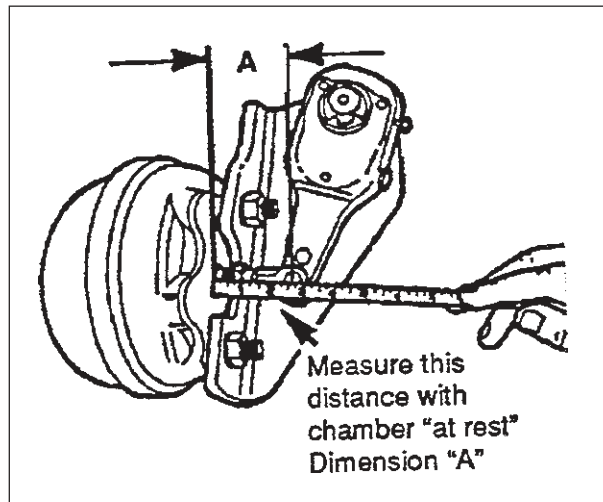

Fig. 8-22 PUSH ROD "AT REST"

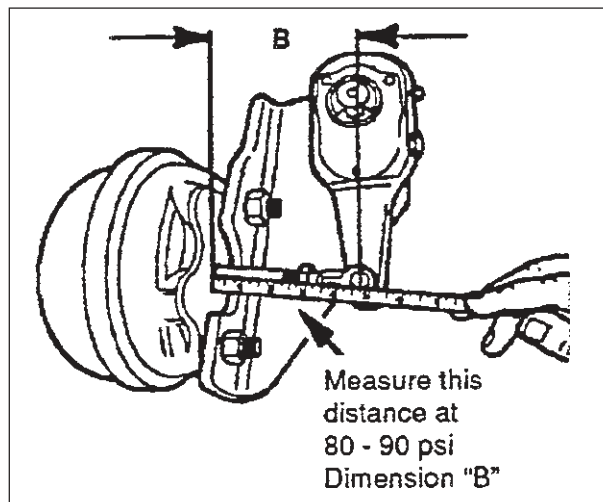

Fig. 8-23 PUSH ROD "EXTENDED"

3. Measure the brake chamber face to the center of the clevis pin (see Fig. 8-23).
4. The difference between the brakes released and applied measurements is the power stroke measurement. If the stroke is less than the maximum stroke for the chamber size (see Table 5), the inspection is complete. If the power stroke is more than the maximum stroke for the chamber size (see Table 5), refer to the section entitled FAILURE ANALYSIS.

AUTOMATIC SLACK ADJUSTER ADJUSTMENT PROCEDURE AT RELINE AND INSTALLATION

An automatic slack adjuster should be manually adjusted after a brake reline and/or installation using the following procedure:

1. Position a wrench or socket over the adjusting mechanism.

NOTE

If the automatic slack adjuster is equipped with a pawl, remove the pawl for the brake adjustment and then properly reinstall the pawl (see Fig. 8-24 Style C). Tighten the pawl to 15-20 ft-lbs.

2. Rotate the adjusting mechanism until the brake shoes contact the drum. Pull on the slack adjuster by hand to make sure it will not move. If there is movement, adjustment was made in the wrong direction and the adjusting hex must be turned in the opposite direction until it will go no further.
3. Reverse the rotation, backing the slack adjuster off one-half (1/2) turn).
4. Measure the chamber power stroke at 80-90 psi brake application pressure as described in the previous section.
5. Take a free stroke measurement as outlined in the section entitled FAILURE ANALYSIS. Make sure you have at least 3/8" free stroke. Free strokes of less than 3/8" can cause brake drag. If you cannot maintain the maximum legal stroke and the free stroke is less than 3/8", contact the brake manufacturer for foundation or brake geometry problems.

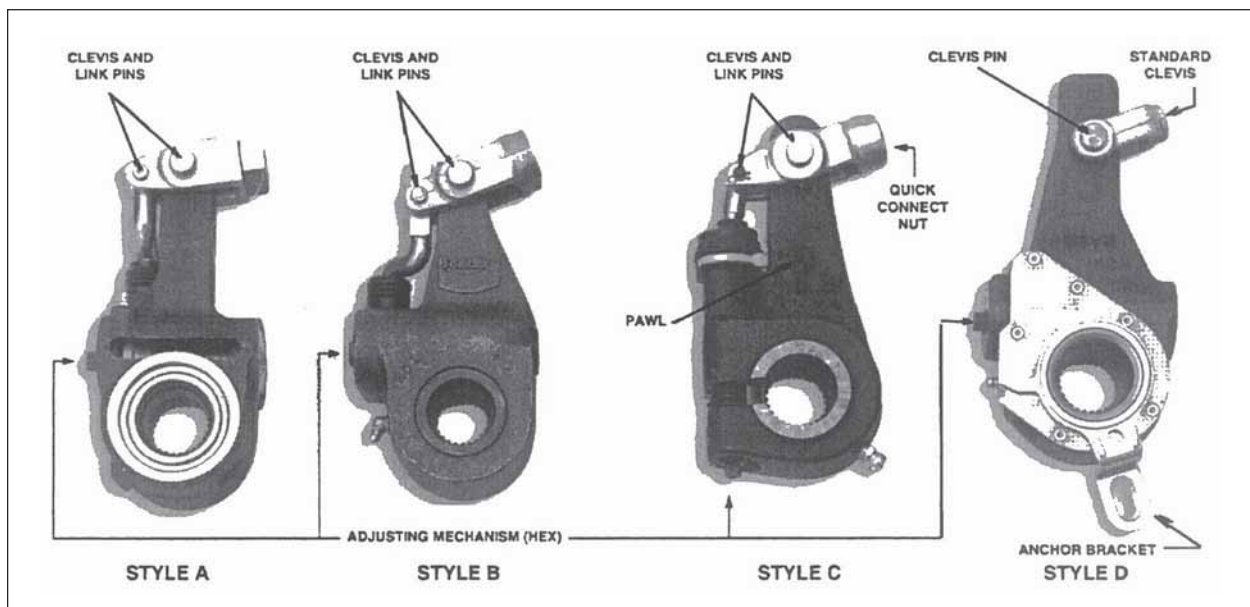

Fig. 8-24 SLACK ADJUSTER TYPES

8.9 SLACK ADJUSTERS (cont'd)

8.9.2 MANUAL AND AUTOMATIC SLACK ADJUSTER MAINTENANCE (cont'd)

ROADSIDE BRAKE ADJUSTMENT

If the driver has to adjust brakes on the road, the following procedure is recommended:

If the vehicle is equipped with an automatic slack adjuster, use a pry bar to pull on the slack adjuster. If movement is more than 5/8", a manual adjustment should be made following the same procedure as described below for a manual slack adjuster. If the automatic slack adjuster is equipped with a pawl, remove the pawl for the brake adjustment and then properly reinstall the pawl. If the automatic slack adjuster needs adjustment, inform maintenance personnel.

1. Block the wheels or mechanically secure the vehicle. On the brakes to be adjusted, spring brakes must be mechanically caged or released with air.
2. Rotate the adjusting mechanism until the brake shoes contact the drum. Using a pry bar, pull on the slack adjuster by hand to make sure it will not move. If there is movement, adjustment was made in the wrong direction and the adjusting mechanism must be turned in the opposite direction. Tap the brake drum with a wrench; you should hear a dull clunk indicating the brake linings are tight against the drum.

3. Back off the slack adjuster a small amount at a time, while tapping on the brake drum with a wrench in between adjustments. Stop backing off the adjuster when you hear a clear ringing sound from the brake drum when tapped with a wrench.
4. Using a pry bar, pull on the slack adjuster by hand. If movement is more than 5/8", adjustment was not done properly or there is a problem with the foundation brake.

NOTE

Some brake chamber push rods are marked to warn of an over-stroke condition. While the marking themselves may vary, the marking system has two basic features. They are: There is a mark on the brake chamber push rod near its clevis attachment to signal that it incorporates a stroke alert indicator (see Fig. 8-25 B). There also is a mark on the brake chamber push rod opposite its clevis attachment end which is exposed from the brake chamber wherever over-stroke occurs (see Fig. 8-25 C).

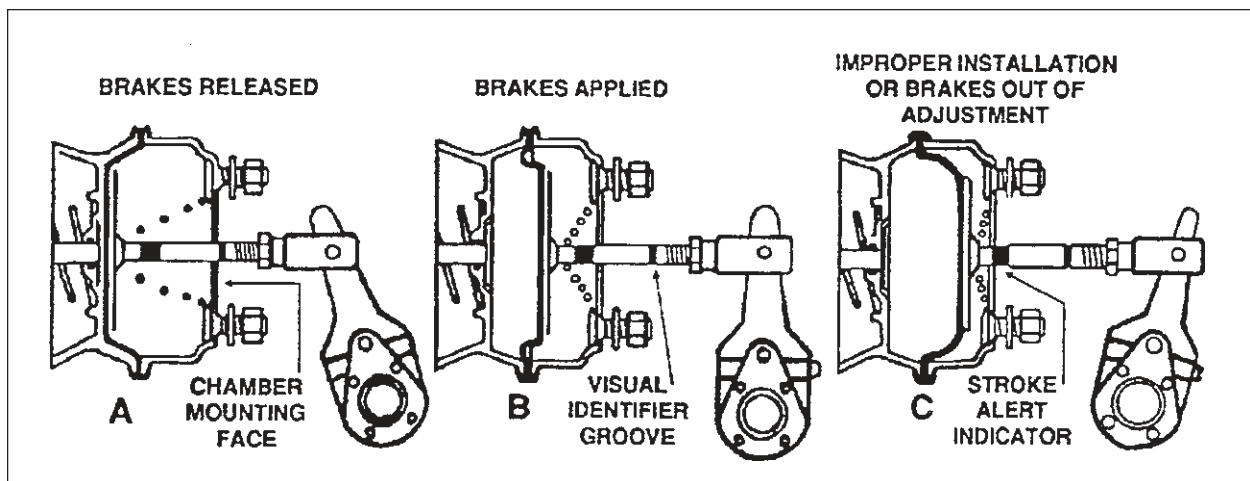

Fig. 8-25 PUSH ROD POSITION

FAILURE ANALYSIS

Manual Slack Adjuster Failure Analysis

Manual slack adjusters should be inspected for gear set wear. To do this, back off the adjusting hex until all spring pressure is relieved from the clevis. Work the adjusting nut 1/4 turn back and forth while watching for cam rotation. If you have 1/8 to 1/4 turn of play without the cam rotating, the manual slack should be replaced. Repeat this procedure every 1/4 turn of the adjusting nut to check the whole gear set.

Automatic Slack Adjuster Failure Analysis

If the power stroke is at or more than the maximum stroke, measure free stroke to determine if the slack adjuster is operational.

FREE STROKE MEASUREMENT

Free stroke is the amount of slack arm movement required to move the brake shoes against the drum. To measure free stroke, perform the following:

1. With brakes released, measure from the brake chamber face to the center of the clevis pin.
2. With a lever, pry the slack adjuster arm until the brake shoes contact the drum and measure the slack adjuster movement (see Fig. 8-26).
3. The difference between the brake released and applied measurements is the free stroke. The free stroke should be 3/8" - 5/8". If the free stroke is in the correct range, the out of spec stroke is due to a foundation brake problem. Check for missing or worn components, cracked brake drums, or improper lining-to-drum contact. If the free stroke is greater than recommended, an automatic slack adjuster function test should be performed.

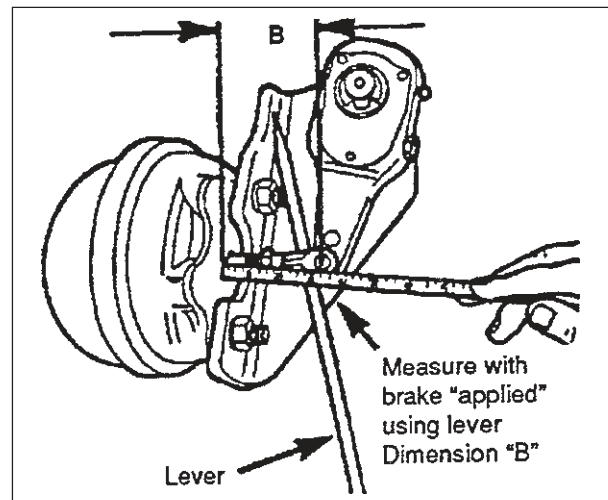

Fig. 8-26 FREE STROKE

8.9 SLACK ADJUSTERS (cont'd)

8.9.2 MANUAL AND AUTOMATIC SLACK ADJUSTER MAINTENANCE (cont'd)

AUTOMATIC SLACK ADJUSTER FUNCTION TEST

1. Remove the pawl, then rotate the adjusting mechanism at least one complete turn as if backing off the brake adjustment (see Fig. 8-27 Style C). The pawl must be installed properly and tightened to 15 - 20 ft-lbs. after backing off the adjuster.
2. Apply the brakes several times and observe whether the adjustment mechanism is rotating in the direction needed to reduce brake chamber pushrod stroke. If the adjusting mechanism does not rotate, the slack adjuster should be replaced.
3. Check back-off torque by rotating the adjusting hex as follows:
 - Style A:** Minimum 15 ft-lbs. counter-clockwise (CCW).
 - Style B:** Minimum 15 ft-lbs CCW.
 - Style C:** Less than 45 in-lbs. CCW (pawl removed)
 - Style D:** Minimum 15 ft-lbs CCW

Consult the manufacturer for more information.

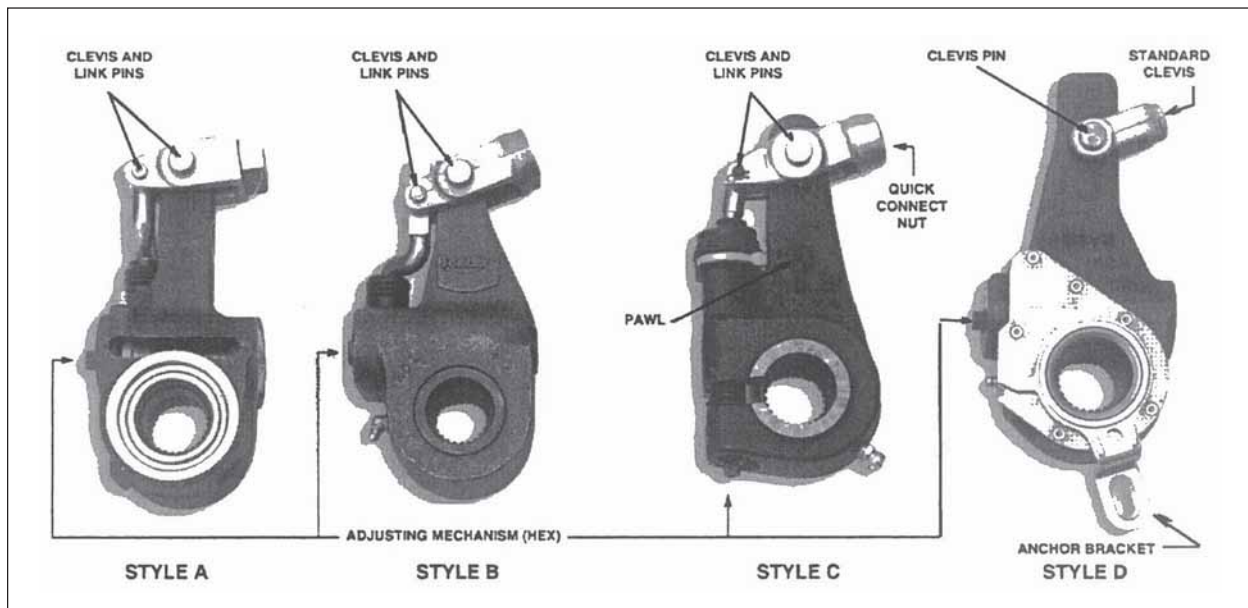

Fig. 8-27 SLACK ADJUSTER TYPES

PREVENTATIVE MAINTENANCE

Every month, 8,000 miles, or 300 operating hours, check brake chamber push rod travel; stroke should be as short as possible without the brakes dragging or the push rod binding. Adjust manual slacks if necessary. Due to different operating conditions, adjustments may be necessary at earlier intervals.

Every 6 months, 50,000 miles, or 1,800 operating hours, lubricate all slack adjusters and clevis pins with manufacturer's recommended lubricant. Check for worn clevises, clevis pins, clevis pin bushings, and control arm/bracket wear. Failure to replace worn components will increase chamber stroke. Lubrication and inspection may be necessary at earlier intervals due to different operating conditions.

8.10 AIR CHAMBER/SPRING BRAKE

Air chambers mounted on the axle use the air supply/pressure from the tractor to apply the service brakes for stopping the vehicle. In addition this air chamber may be equipped with a spring brake that applies the brake when the service side of the brake loses air. The spring brake side of the system is used as a parking and/or emergency brake if the service side fails.

Spring brakes should not be serviced by anyone in the field unless they have been trained in the proper procedure. Do not work on the brakes unless the springs are caged or locked out. Do not move the trailer if the springs are caged.

When caging or locking out the spring brakes, follow this procedure:

1. Place chocks in front of and behind the trailer wheels.
2. Insert the release bolt, stored on the side of the chamber, into the hole in the head and through the piston.
3. Turn the release bolt clockwise until it stops and locks.
4. Pull release bolt out as far as possible and run the nut down while holding the bolt in place.
5. Use a wrench to turn the release bolt nut clockwise until the bolt extends about 3 inches.
6. Be sure the release bolt is locked in position.
7. The spring is now caged and the trailer can be moved.
8. Always release the spring before placing the trailer back in service.

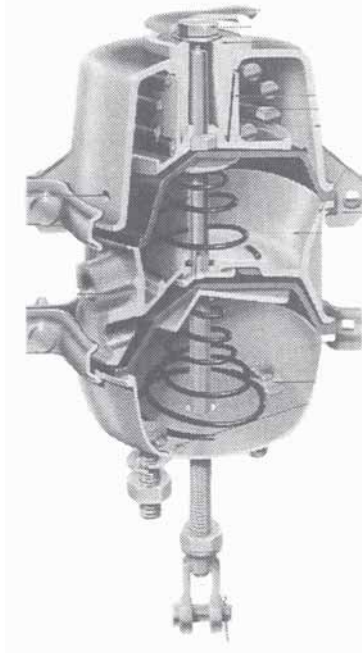

Schematic



Axle

Fig. 8-28 SPRING BRAKE

8.11 SUSPENSION SYSTEM

The suspension system is the group of components that connect the axle to the main trailer frame and absorb the shock loads from the road. Walinga trailers can be equipped with either a mechanical or air ride suspension system. Either system works well and will provide many years of trouble-free service.

8.11.1 AIR RIDE SUSPENSION

An air ride suspension consists of air springs that are inflated and pressurized by the trailer air system and controlled by a height control valve. It is a simple system that requires minimal servicing and maintenance to perform well.

Visually inspect the trailer at the start of the day or trip to check the condition of the suspension. When the suspension is in good condition, the frame will be level and at the proper ride height. Also, check for loose fasteners or damaged components. Correct any problems before placing the trailer into service. Problems caught early and corrected minimize cost and downtime.

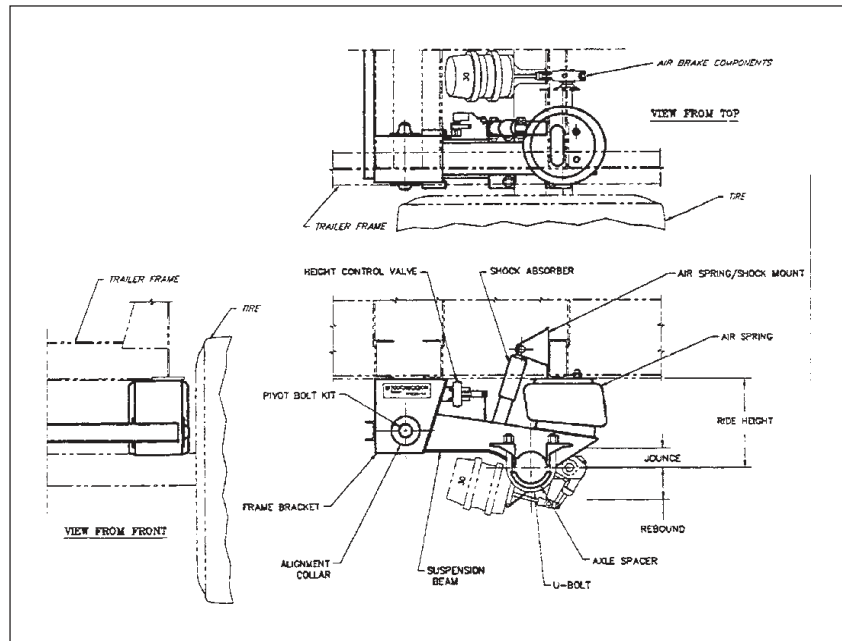

Fig. 8-29 SUSPENSION

Table 6 Bolt Torque Values For Hendrickson Turner Suspensions

Description	Size	Torque
Quik-Align™ Pivot Bolt	7/8"-9	475-525 Ft. Lbs
Shock Bolt	3/4"-10	150-175 Ft. Lbs.
Air Spring Bolt (Lower)	1/2"-13	25-35 Ft. Lbs.
Air Spring Nut (Upper)	3/4"-16	45-55 Ft. Lbs.
Brake Dust Shield Bolt	5/16"-18	160-180 In. Lbs.
ABS Bracket Bolt	1/4"-20	75-100 In. Lbs.

Every 5,000 miles (8,000 km) or monthly, check the clearance around all the suspension system components. Correct any interference problem. Retorque all the fasteners to their specified torque.

Every 25,000 miles (40,000 km) or 3 months, visually inspect all components and welds for cracks, distortions or other damage. Repair or replace all defective components before placing unit into service.

Typical repairs include but are not limited to:

1. **Air Spring Replacement:**

Air springs are designed to be virtually trouble-free throughout their life. Problems seldom occur unless they are cut, punctured, abraded, pinched or torn and then they must be replaced.

- a. Block the wheels to prevent trailer movement.
- b. Exhaust air from the suspension system.
- c. Raise and support the frame on safety stands.

NOTE

Do not raise frame too high unless shock absorbers are installed to prevent over-extending the air spring.

- d. Disconnect the air lines to the air spring(s).
- e. Loosen mounting bolts and remove air spring(s).
- f. Install new air spring(s).
- g. Tighten mounting bolts to their specified torque of 50 ft. lbs. (68 N.m).
- h. Install air lines and tighten to their specified torque.
- i. Repeat on other air springs.
- j. Remove stands from under frame.

2. **Shock Absorber Replacement:**

Shock absorbers remove energy from the suspension system as the trailer encounters holes and bumps on the road surface. They also act as a stop for the air springs to prevent the axle from moving too far away from the frame and tearing or damaging the air spring.

- a. Remove the upper and lower mounting bolts.
- b. Remove old shock and install new one.

IMPORTANT

Use only correct Hendrickson Turner replacement parts. Substitute parts do not work with the suspension system.

- c. Secure shock by tightening mounting bolts to their specified torque of 250 ft. lbs. (338 N.m).

3. **Pivot Bushing:**

Pivot bushings are a very durable, long lasting component. Bushing failures are rare and should be attempted only when all other problem causes have been eliminated. A bushing removal/installation tool is available from Hendrickson Turner when replacing the bushing and can be borrowed from your dealer or distributor. A 10 ton portable hydraulic press must be supplied by the customer. Purchase the bushing replacement kit that includes a new bushing, pivot bolt kit and lubricant.

When replacing the bushing, follow this procedure:

- a. Use a torch to "cut off" the Huck fasteners from the clamping bolt.
- b. Press out the old bushing and press in the new one.
- c. Install the clamping bolt and tighten the fastener to 800 ft. lbs. (1080 N.m).
- d. Tack weld the nut to the bolt to prevent loosening.

8.11 SUSPENSION SYSTEM (cont'd)

8.11.1 AIR RIDE SUSPENSION (cont'd)

4. **Air Control (Ride Height Control):**
An air ride suspension system uses the air from the tractor to pressurize the air springs. A single height control valve is used to monitor the height of the frame above the axle and add/exhaust air from the system as required to maintain this dimension. Normally this dimension is set for your trailer and never changes.

The height control valve is located on the rear axle of the axle assembly area on the trailer and controls the adding/exhausting of air to the air springs. As the dimension between the frame and axle increases, the control lever moves down and air is exhausted from the system. As the dimension decreases, air is added to raise the frame. All valves incorporate a 5 to 15 second time delay to minimize jerking or cycling. Replace valve if not functioning properly.

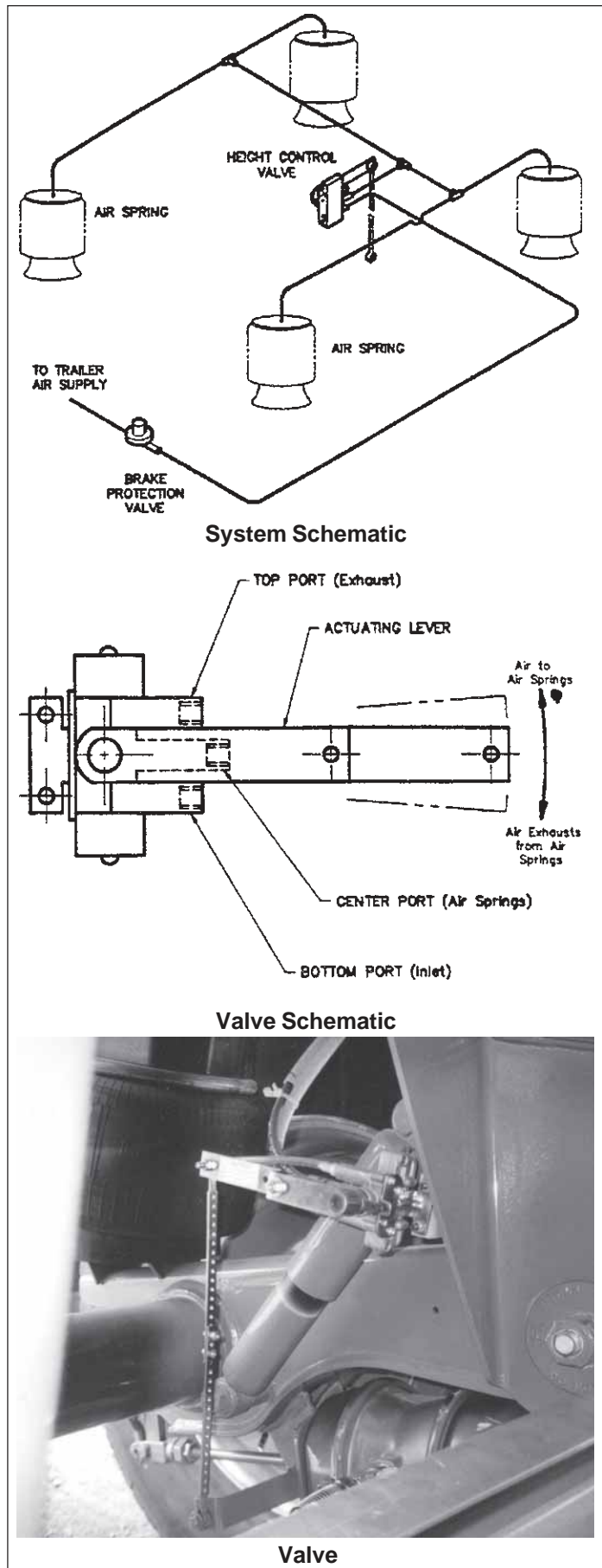

Fig. 8-30 RIDE HEIGHT CONTROL

5. **Dump Valve:**

All air control systems are equipped with a dump valve that allows the operator to exhaust the air from the system as required.

a. **Always dump the air when parking the trailer and before unhooking.**

b. Dumping the air is optional when:

i. **Loading:** The rapid or sudden addition of load to the trailer can cause the control valve to search for neutral. Exhausting the air rests the frame on the interval bumper and prevents the valve from searching. When the loading is completed, close the valve to repressurize the system.

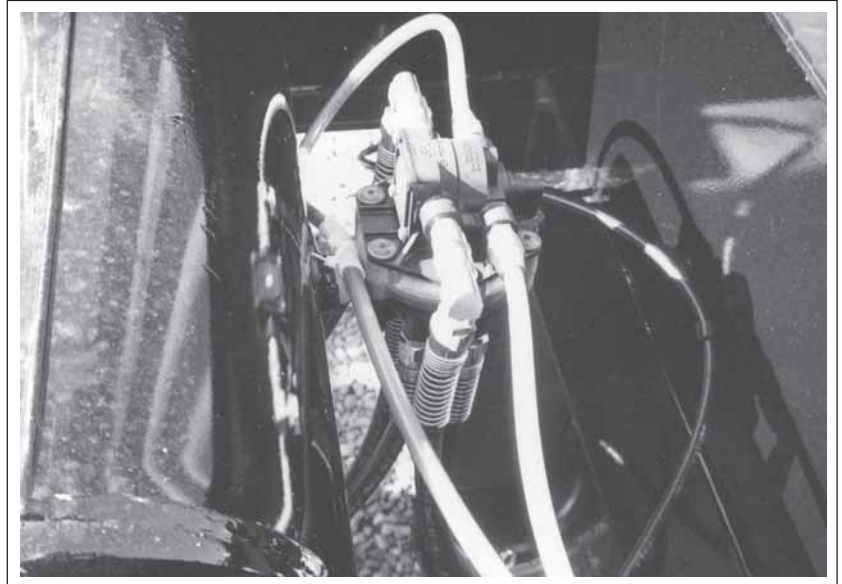

Fig. 8-31 DUMP VALVE

ii. **Unloading:** Dumping rapidly can also require the valve to search for neutral. Close the valve when the unloading is completed to repressurize the system.

8.11 SUSPENSION SYSTEM (cont'd)

8.11.2 MECHANICAL SUSPENSION

Two types of mechanical suspensions are available on the trailer and must be specified and ordered from the factory. Both work well and provide the customer with a choice.

The standard suspension for the tandem and triaxle models are the Reyco 21B 8 leaf and the Hutch 9700 3 leaf. Both are designed to require minimal service and maintenance on a trailer. However, these service intervals and maintenance procedures must be followed:

Service Intervals:

1. Follow the break-in procedure specified in Section 4.3.
2. Visually inspect the suspension at the start of the day or trip for bent, broken or loose components. Always correct these conditions and perform a complete check-out of the suspension before placing the trailer back in service.
3. After each additional 25,000 miles (40,000 km), or every 3 months, retorque all the fasteners to their specified torque per the following table. Always use an accurate torque wrench when retorquing fasteners and attach to the nut.
4. 25,000 miles (40,000 km) or every 3 months, inspect the following:
 - a. Check position of clamp if moveable clamps used. Clamping legs must be centered over slot in end tube.
 - b. Check fit and function of all bushings.
5. In addition to checking the alignment at the recommended intervals, axle alignment should be checked when any of the following conditions occur:
 - a. Discovery of loose fasteners or components.
 - b. Discovery of elongated holes in a suspension system component.
 - c. Whenever bushings are replaced.
 - d. Whenever excessive or abnormal tire wear is observed.

- c. Check all hanger and hanger bracing welds for cracks.
- d. Check all other welds for signs of cracks or distortion.
- e. Check fit of springs in hangers and equalizers.
- f. Check equalizers for excessive wear at spring ends.
- g. Check suspension system alignment.

IMPORTANT

A loose fastener is defined as one whose torque has dropped below its specified level.

sion system component.

Table 7 Suspension Fastener Torque Requirements

Description	Size	Torque		
		Ft. Lbs.	N.m	
Equalizer Shaft (All Spread)	49" Spread	1-1/4" Nut	575-625	780-850
	54"-65-1/2" Spread	3/4" Capscrew	200-225	270-305
	72"-109" Spread	2-1/2" Nut	300-325	410-445
		1-1/2" Nut	200-225	270-305
U-Bolt Nuts		300-325	410-445	
Torque Arm Bolt Nuts	1"	160-200	216-270	
Torque Arm Clamping Nuts	1/2"	80	110	
	3/4"	175-200	236-270	
Spring Retainer Nuts	1/2"	80	110	

8.11 SUSPENSION SYSTEM (cont'd)

8.11.3 SUSPENSION SYSTEM SCHEMATICS

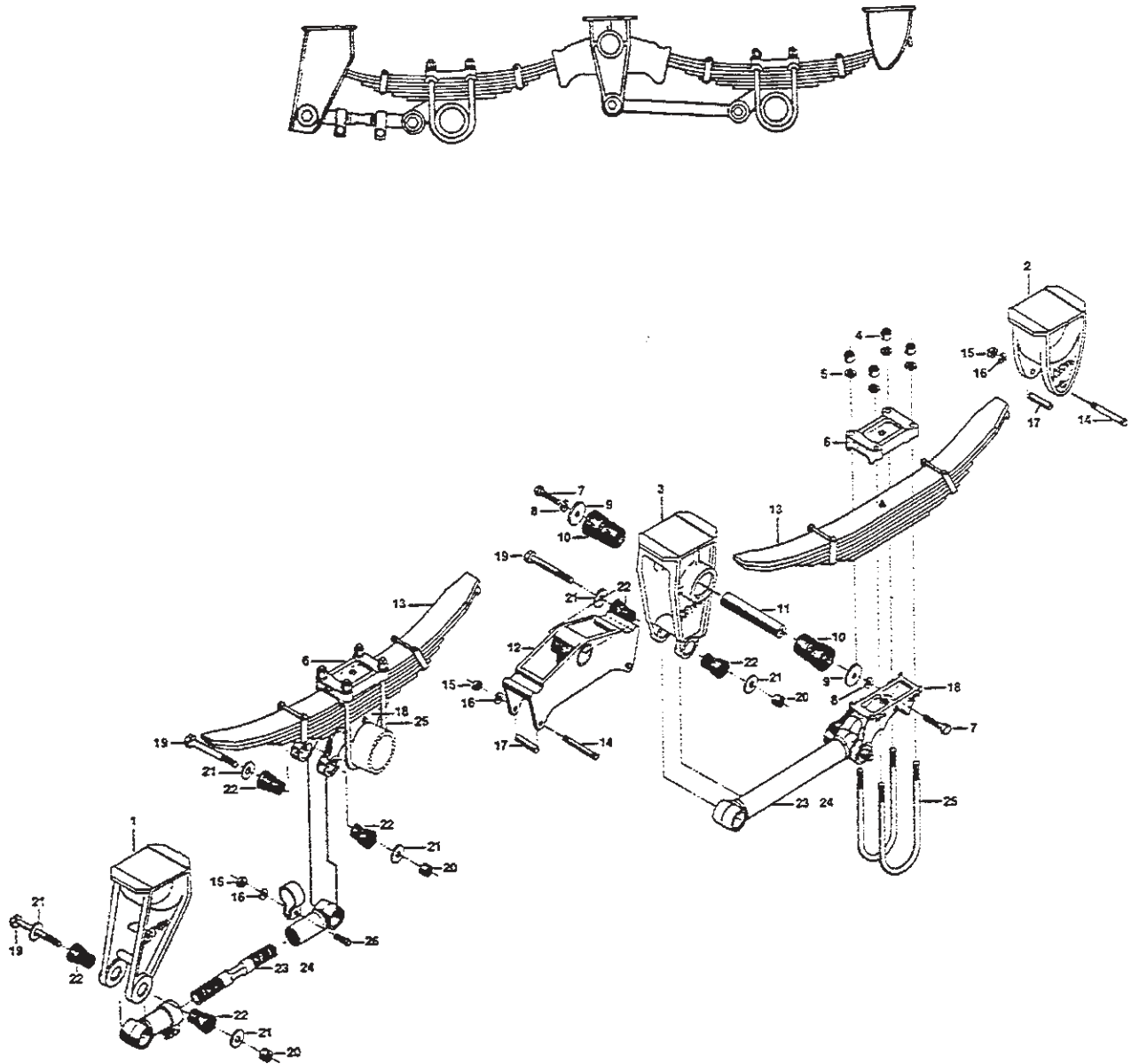

8.12 TIRE WEAR PATTERNS

The way your tires wear is a good indicator of other parts of the suspension. Abnormal wear patterns are often caused by the need for simple maintenance or axle alignment.

a. **Over-Inflation:**

Excessive wear at the center of the tire indicates the air pressure in the tire is consistently too high. The tire is riding on the center of the tread and wearing it prematurely. Occasionally, this wear pattern can result from outrageously wide tires on narrow rims. The cure for this is to replace either the tires or the wheels.

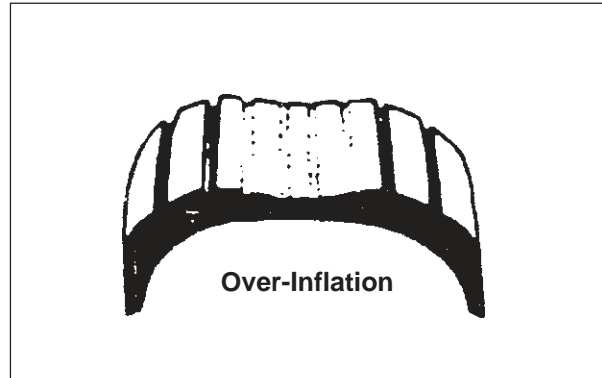

Fig. 8-32 OVER-INFLATED

b. **Under-Inflation:**

This type of wear usually results from consistent under-inflation. When a tire is under-inflated, there is too much contact with the road by the outer treads, which wear prematurely. When this type of wear occurs, and the tire pressure is known to be consistently correct or the need for axle alignment could be indicated.

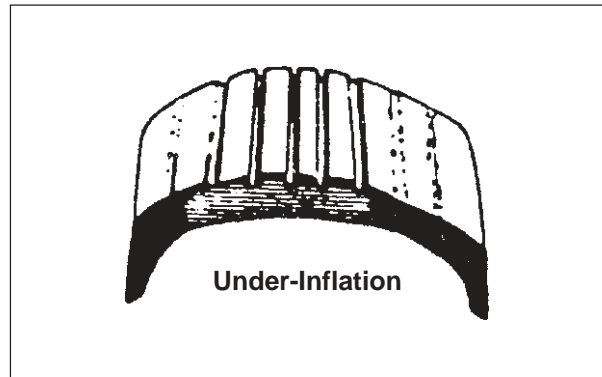

Fig. 8-33 UNDER-INFLATED

c. **Feathering:**

Feathering is a condition when the edge of each tread rib develops a slightly rounded edge on one side and a sharp edge on the other. By running your hand over the tire, you can usually feel the sharper edges before you will be able to see them. The most common causes of feathering are incorrect toe-in setting, deteriorated bushing in the suspension or misalignment.

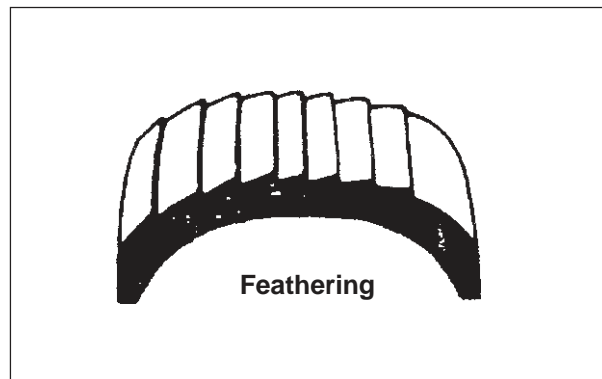

Fig. 8-34 FEATHERING

d. **One-Side Wear:**

When an inner or outer rib wears faster than the rest of the tire, the need for axle alignment is indicated. There is excessive camber in the axle causing the wheel to lean too much excessive load on the one side of the tire. Misalignment could also be due to sagging springs, or worn suspension system components.

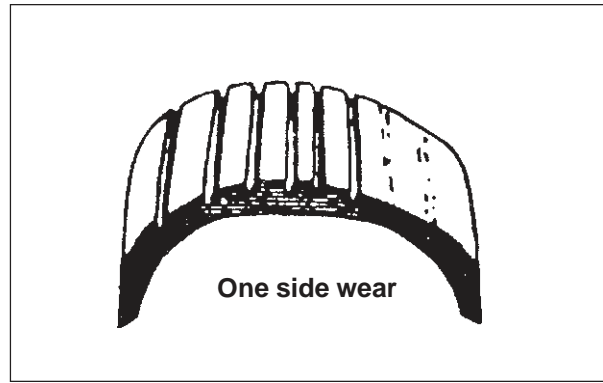

Fig. 8-35 ONE-SIDE WEAR

e. **Cupping:**

Cups or scalloped dips appearing around the edge of the tread almost always indicate worn (sometimes bent) suspension parts. Adjustment of axle alignment alone will seldom cure the problem. Any worn component that connects the wheel to the suspension can cause this type of wear. Occasionally, wheels that are out of balance will wear like this, but wheel imbalance usually shows up as bald spots between the outside edges and center of the tread.

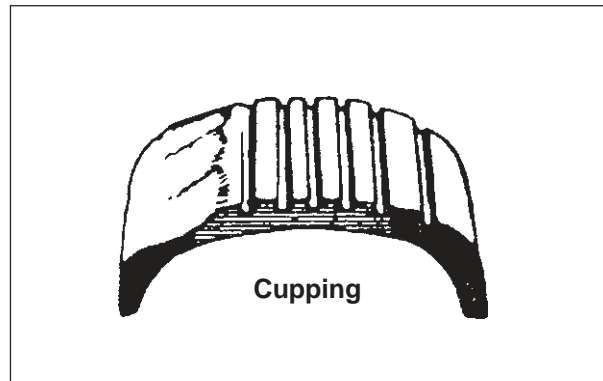

Fig. 8-36 CUPPING

f. **Second Rib Wear:**

Second rib wear is usually found only in radial tires, and appears where the steel belts end in relation to the tread. It can be kept to a minimum by paying careful attention to tire pressure and frequently rotating the tires. This is often considered normal wear but excessive amounts indicate that the tires are too wide for the wheels.

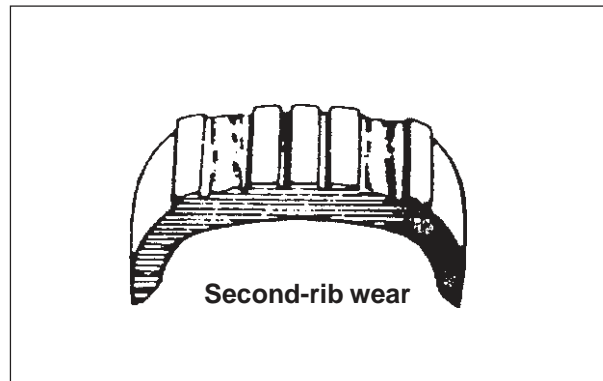

Fig. 8-37 SECOND RIB WEAR

8.13 AIR SYSTEM

Trailers are equipped with an air system, that is pressurized by a compressor on the tractor, for operating the discharge gates, brakes and air suspension (if so equipped). All components must be in good condition for the system to function and perform as intended. The air system must be inspected to be kept in good condition and functional checks performed to be sure it is operating as required.

8.13.1 AIR SYSTEM INSPECTION

The pre-trip or pre-start inspection include several air system related checks, inspections or tasks including but not limited to:

Daily

1. Check that the glad hands are clean and in good condition. Check seals in glad hand. Clean, repair or replace as required.
2. Check that the air hoses between the tractor and the trailer are routed to prevent rubbing, chaffing or pinching. Reroute to correct condition if required.
3. Drain moisture from all air tanks. Pull on the cable attached to drain valve on the bottom of each tank until the water or spray no longer can be seen.

IMPORTANT

Tanks must be drained daily in high humidity and cold temperature conditions to prevent getting water or ice in the system.

4. Check that all the lines and hoses conveying air along the frame are tied up and secured to prevent dragging, scuffing or snagging. Tie up or protect as required to correct the condition. Damaging an air system component can cause a sudden loss of pressure and result in a loss of service brakes.

IMPORTANT

New FMVSS-121 regulations mandate higher pressures in the supply line to insure proper brake operation. Set the compressor pressure for cut-in to 105 psi and cut-out to 120 psi. Do not use additives in the air systems.

8.13.2 AIR SYSTEM FUNCTIONAL

A vehicle air system is a combination of the components on the tractor and the trailer. All must be maintained in good condition for the entire system to function as required. Although a visual check will indicate the outer condition of the components, it does not indicate the leaks or responsiveness of the system. To evaluate the integrity and responsiveness of the system, perform these functional checks:

1. Attach the trailer to a tractor and connect all the air and electrical lines.
2. Block wheels.
3. Stop tractor engine and exhaust air from all tanks.
4. Start engine and run at fast idle (1200-1500 RPM) to charge the air system.

Verify that:

- a. Low pressure alarm goes off when the system pressure exceeds 50 psi.
- b. Increasing the system pressure between 50 psi and 80 psi takes less than 3 minutes.
- c. The compressor cuts out when the system pressure exceeds 120 psi.
- d. Fan brakes to use air. Compressor must engage when system pressure drops below 105 psi.

NOTE

Release spring brakes before fanning service brakes.

5. Push emergency valve to charge trailer system. Apply and release service brakes.
6. Build system above 120 psi and stop engine.

Verify that:

- a. Main tank pressure does not drop more than 18 psi when brakes are fully applied using brake pedal. If pressure drop exceeds 18 psi, adjust brakes and recheck.
- b. System pressure should not drop more than 4 psi per minute. Listen for audible leaks.
- c. Release foot valve, fan treadle to drop main reservoir pressure. Brakes should dynamite automatically when the pressure drops below 60 psi.

Adjust or repair system until these conditions are met.

8.13.3 AIR SYSTEM SCHEMATICS

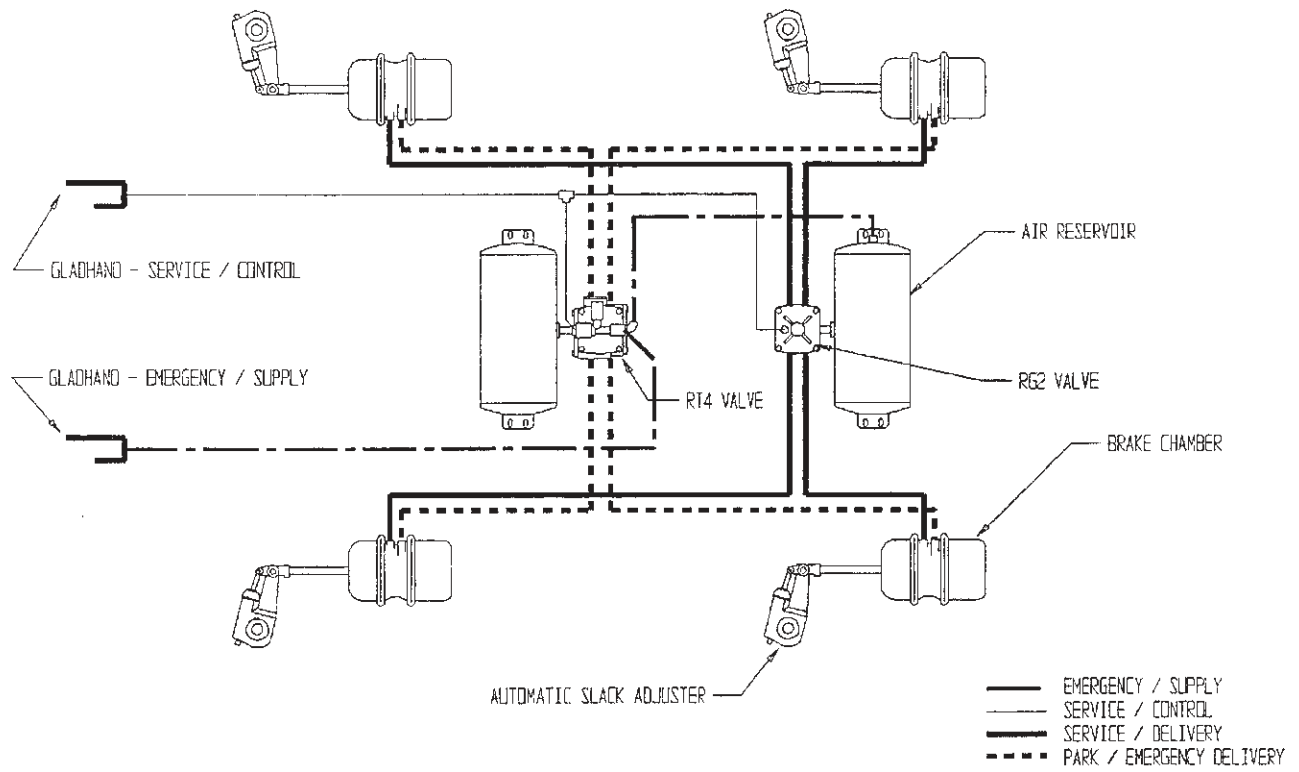

Tandem Axles - 2 Tank 2 Valve

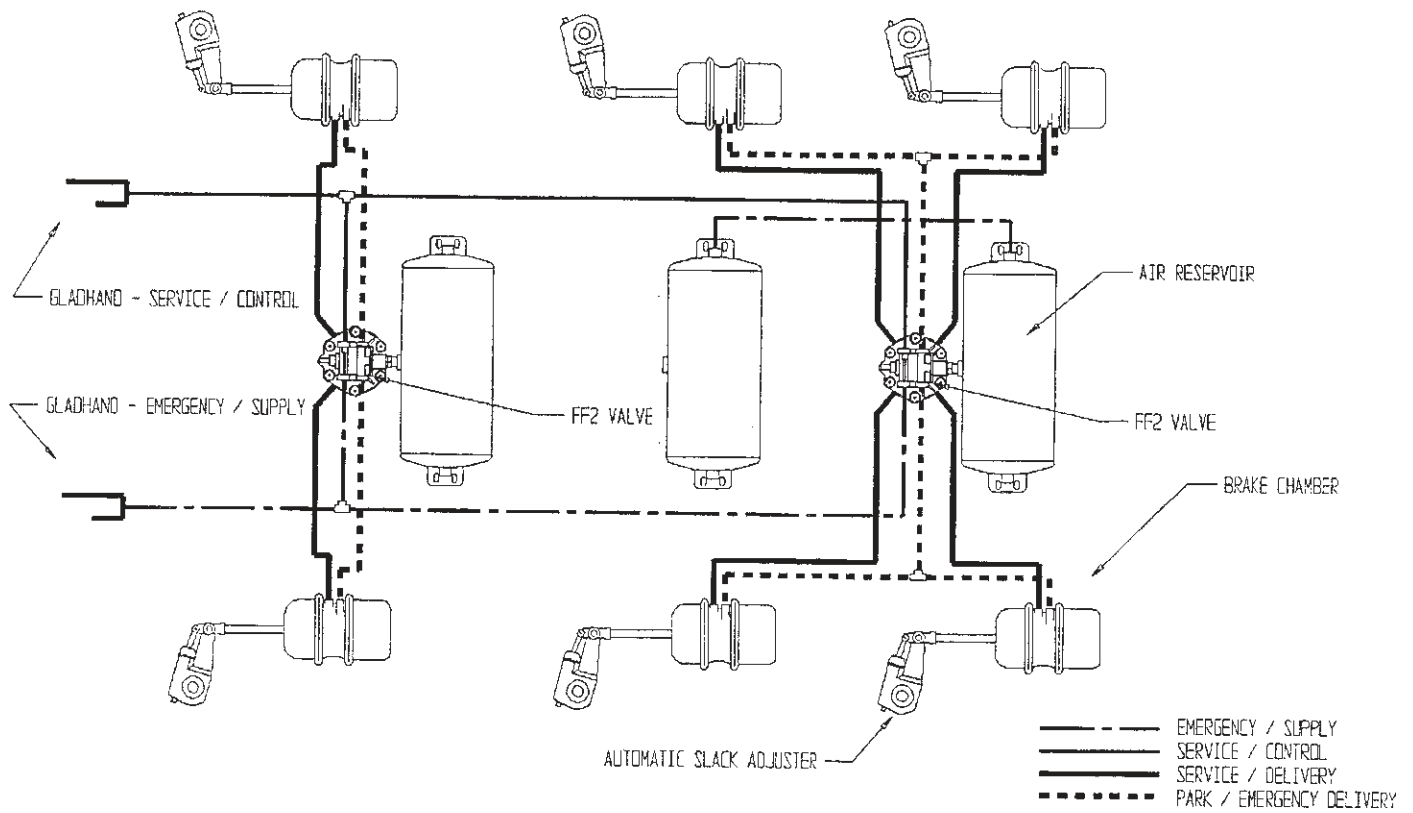

Triaxle - Tridem W/FF2

8.14 ABS VEHICLE CONTROL SYSTEM

Trailers can be equipped with a system that controls the brakes on a vehicle to prevent wheel lock-up when braking. The system consists of an ECU (Electronic Control Unit), Modulator (ABS modulator valve), tooth wheel, wheel speed sensor and wiring harness. The system configuration is determined by the number of wheel sensors and relay valves in the system. The system is designed with a self-diagnostic feature that monitors the condition of the system and can indicate system faults through a series of cooled flashing lights. Each operator and/or serviceman should have a copy of the Service Booklet from Rockwell that explains the Blink Code Diagnostics System. Use the ECU/Valve serial number and configuration to specify the applicable booklet for your system.

1. Power:

The system can be powered by tapping into the "live" wiring harness or through the brake light circuit. With the former, the system is ON whenever the ignition key is turned on. With the latter, the system is ON when the brakes are applied.

2. Function:

Sensors on each wheel monitor wheel speed and transmit a signal to the ECU. During heavy, severe and emergency braking or hazardous road conditions, the ECU monitors and compares the speed of each wheel to determine if any are slowing too rapidly. If a wheel is slowing too rapidly, the ECU works with the modulator valve to relieve the air pressure to the brake son that wheel to prevent lock-up. By preventing wheel lock-up, each wheel provides maximum braking force and eliminates trailer instability.

3. Warning Lamp:

Each system is equipped with a warning lamp to display the condition of ABS system to the driver/operator. Be familiar with the meaning of the warning lamp codes before using the trailer.

a. On a **stoplight activated** system, the warning lamp comes ON when you apply the brakes and goes OFF when you release the brakes on a stationary vehicle.

b. On a **constant-power** system, the warn-
Warning Lamp With Stoplight Power

Brakes	Fault in System	Vehicle Speed	Warning Lamp
Released	N.A.	N.A.	Off
Applied	N.A.*	< 4 mph	On
Applied	No	> 4 mph	Flashes once, then stays off for remainder of stop.
Applied	Yes	N.A.*	On for duration of stop.

* At less than 4 mph, you cannot tell whether the light indicates a fault or an incomplete self-check. To tell if there is a fault, you must apply the brakes while driving faster than 4 mph to see if the light stays on during the application.

ing lamp comes ON when you turn the ignition ON and goes OFF when the vehicle exceeds 4 mph (6 km/h).

Warning Lamp With Constant Power

Ignition	Fault in System	Vehicle Speed	Warning Lamps (on Trailer and Dash)
Off	N.A.	N.A.	Off
On	N.A.**	< 4 mph	On**
On	No	> 4 mph	Off
On	Yes	N.A.**	On

* The light comes on at the initial activation of the ECU, not each time the vehicle slows down below 4 mph. Until the vehicle initially exceeds 4 mph, you cannot tell if the light indicates a fault or an incomplete self-check. To tell if there is a fault, you must drive faster than 4 mph and see if the light stays on. Once vehicle speed exceeds 4 mph, the light remains off unless a fault occurs or the ignition is turned off and then turned on again.

4. **Faults:**
Whenever there is a fault/problem with the system or any of its components, the warning lamp will not come ON per the tables listed on the previous page. The system is designed with an internal self-diagnostic and memory system to tell service personnel the cause and location/site of the fault/problem through their diagnostic blink code system.

5. **Blink Code Diagnostics:**
A system can be accessed using a special diagnostic tool to plug into the ECU to identify the faults/problems and locations. Purchase the appropriate tool and Maintenance Booklet for your system to keep it in good operating condition. Each system is designed with blink code diagnostic code to identify fault cause and location as defined in Maintenance booklet. Always correct any faults as they are identified to maintain the unit in top operating conditions.

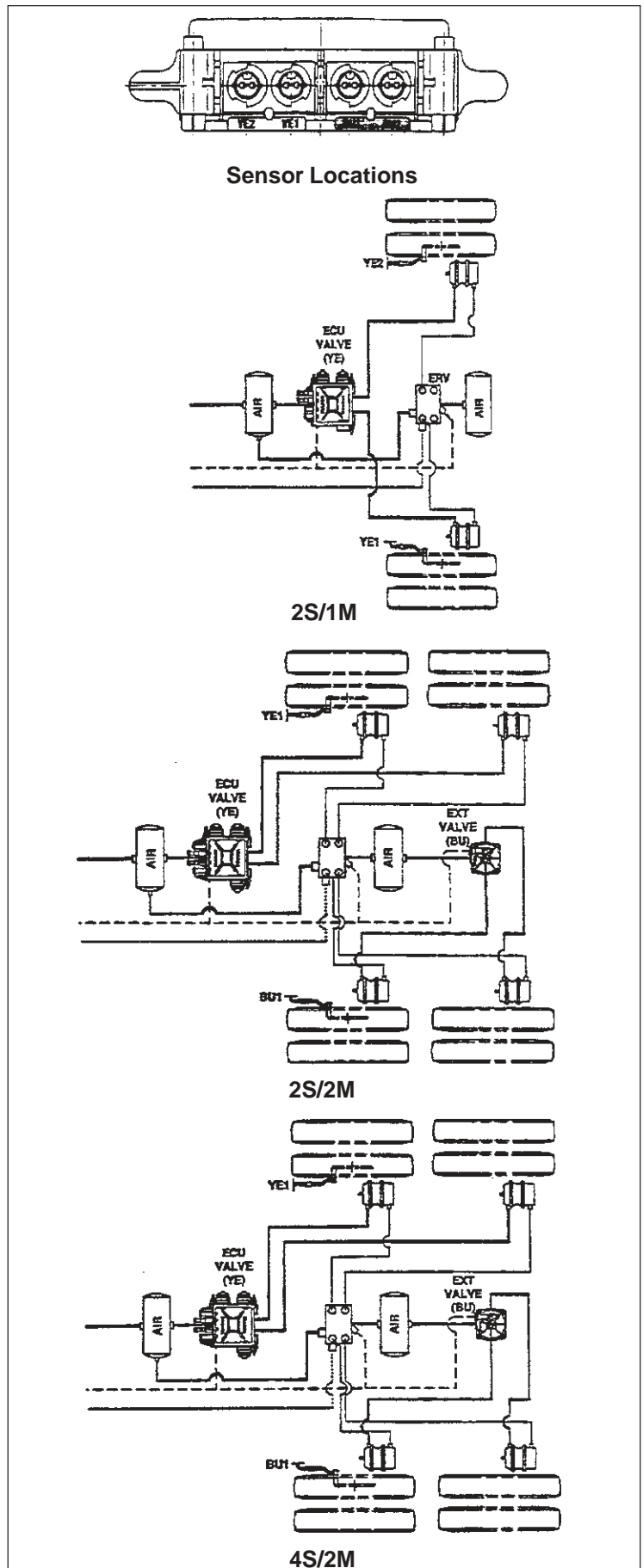
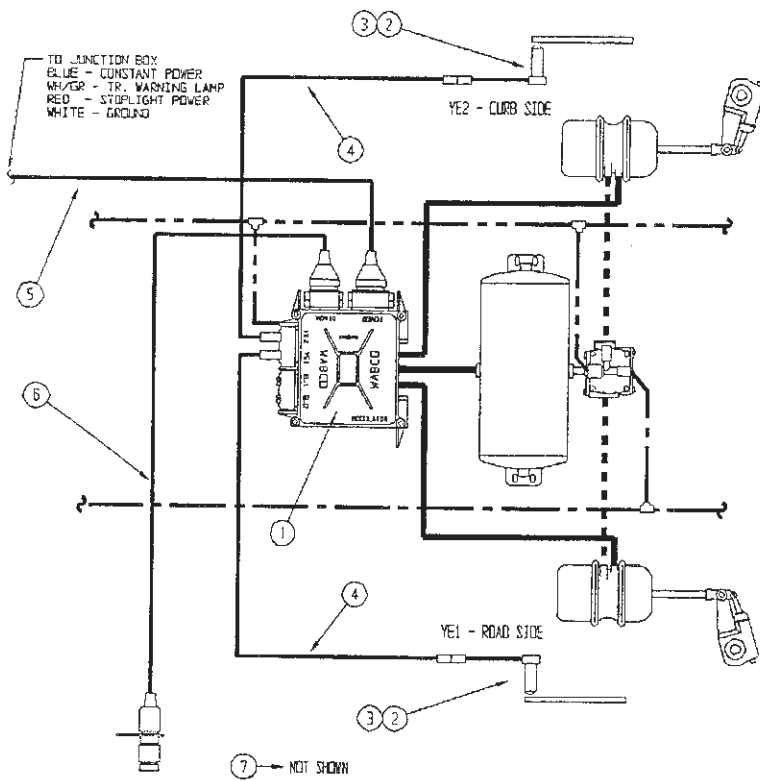

Fig. 8-38 ABS CONFIGURATION

8.15 ABS SCHEMATICS



- EMERGENCY / SUPPLY
- - - - SERVICE / CONTROL
- SERVICE / DELIVERY
- PARK / EMERGENCY DELIVERY

NOTE: FOR LIFT AXLE APPLICATION, INSTALL NORMALLY CLOSED PRESSURE SWITCH INTO SUSPENSION LIFT AIR CIRCUIT IN ORDER TO DISCONNECT ECU GROUND CIRCUIT. (DISABLES ABS FOR LIFT AXLE WHEN AXLE IS IN RAISED POSITION)

2S/1M

7	1	# 3305-1-1242	ECU MOUNTING BRACKET	79-17672-6
6	1	# A1-3237-L-1130	DIAGNOSTIC CABLE W/TOOL	79-17673-6
5	1	# 449 315 150 0	POWER CABLE - 4 COND. - 15 m.	79-17674-6
4	2	# 449 713 018 0	SENSOR EXT. CABLE - 1,8 m.	79-17681-6
3	2	# 899 760 510 4	SENSOR CLIP	79-17677-6
2	2	# 441 032 809 0	SENSOR ASS'Y - 1 m. LEAD	79-17678-6
1	1	# 472 560 011 0	ECU/VALVE - 2S/1M	79-17682-6
ITEM	QTY.	MATERIAL	MATERIAL SPECIFICATION	STOCK NUMBER

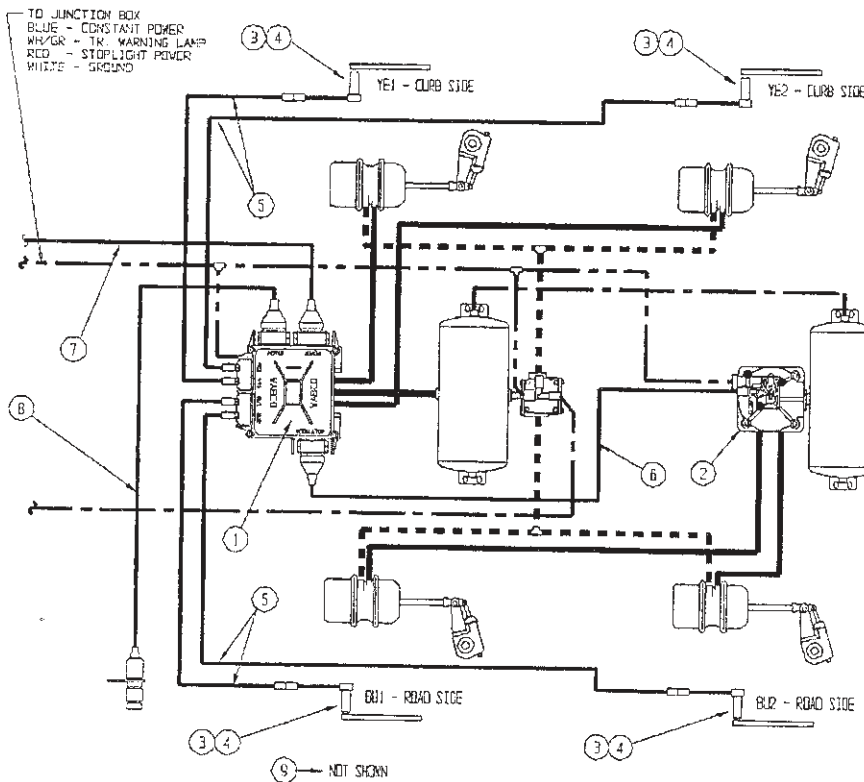

- - - - EMERGENCY / SUPPLY
- SERVICE / CONTROL
- SERVICE / DELIVERY
- PARK / EMERGENCY DELIVERY

NOTE: - SYSTEM SHOWN AS PER TANDEM AXLE SETUP.

- FOR TRIDEM AXLE SETUP, USE SENSORS ON FIRST AND LAST AXLES ONLY.
- INSTALL SERVICE/DELIVERY LINES FOR CENTER AXLE SIMILARLY AS SHOWN.

4S/2M

9	1	# 3305-1-1242	ECU MOUNTING BRACKET	79-17672-6
8	1	# A1-3237-L-1130	DIAGNOSTIC CABLE W/TOOL	79-17673-6
7	1	# 449 315 150 0	POWER CABLE - 4 COND. - 15 m.	79-17674-6
6	1	# 449 421 020 0	RELAY VALVE EXT. CABLE - 2 m.	79-17675-6
5	4	# 449 713 030 0	SENSOR EXT. CABLE - 3 m.	79-17676-6
4	4	# 899 760 510 4	SENSOR CLIP	79-17677-6
3	4	# 441 032 809 0	SENSOR ASS'Y - 1 m. LEAD	79-17678-6
2	1	# 472 195 002 0	RELAY VALVE - 4 PORT	79-17679-6
1	1	# 472 500 012 0	ECU/VALVE - 4S/2M (AUTO CON.)	79-17680-6
ITEM	QTY.	MATERIAL	MATERIAL SPECIFICATION	STOCK NUMBER

8.16 ELECTRICAL SYSTEM

All trailers are equipped with an electrical system for providing power for lights and electrical controls. All components are designed to minimize the effects of foul weather and adverse operating conditions. However, it is the responsibility of the operator to check and verify that all components are in good condition and functioning as intended.

During the daily or pre-trip inspection, always verify that each light functions as required. It may be helpful to work with another individual to verify the function of the brake or turn signal lights. A properly functioning electrical system is the only way an operator can communicate his intentions to other drivers. Checking the electrical system includes but is not limited to:

1. Replace any bulb that is burned out.
2. Clean all reflective lenses. Replace any that are cracked or broken.
3. Clean all connections and terminals to a light that is flickering.
4. Reroute and secure any wires or cables that are dangling or have snagged on something.
5. Check the integrity of the seal around each light. Replace any seal that is cracked or damaged.

Table 8 Trailer Light Requirements

Function	P/N	Size (Watts)
4" Tail Lamp		8
Signal/Brake		27
Side Signal		27
Clearance		8
Marker		5

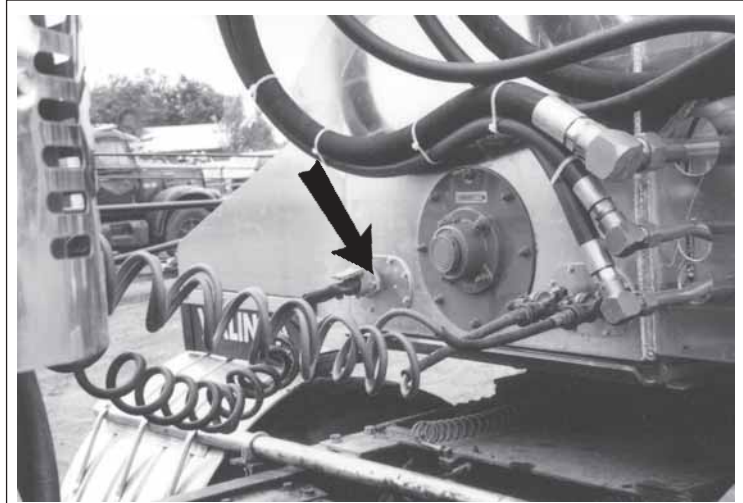

Electrical Connectors



Terminal Box



Rear

Fig. 8-39 LIGHTING

8.16.1 ELECTRICAL SCHEMATICS

8.17 HYDRAULIC MANIFOLD SCHEMATICS

BILL OF MATERIALS		
ITEM	QTY	NUMBER DESCRIPTION
1	2	59-65757-6 FLOW REGULATOR
2	9	59-73089-6 COIL
3	4	59-73091-6 COIL
4	1	59-77118-6 SOLENOID
5	3	59-78439-6 SOLENOID
6	6	59-78440-6 SOLENOID
7	1	59-78442-6 FLOW REGULATOR
8	3	59-78447-6 RELIEF
9	6	59-92692-6 DIRECT
10	3	59-92693-6 SHUTTLE
11	1	59-92695-6 LOGIC
12	1	59-92697-6 DIVIDER
13	1	59-92698-6 BRAKE RELEASE
14	1	59-92699-6 SOLENOID
15	1	59-96910-6 SOLENOID

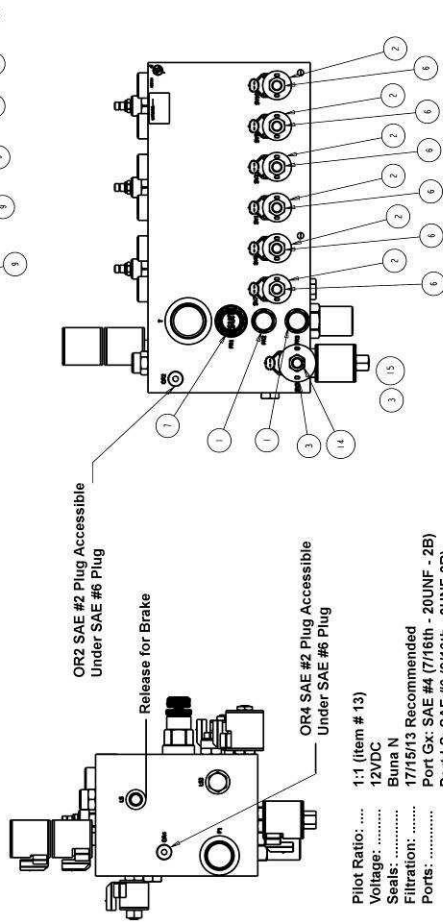
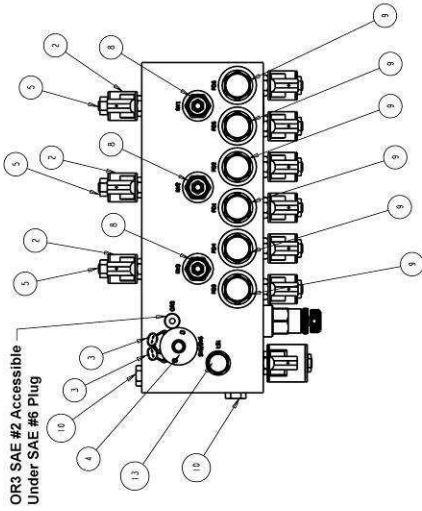

- 1:1 (Item # 13)
- 12VDC
- Buna N
- 17/15/13 Recommended
- Port Gx: SAE #4 (7/16th - 20UNF - 2B)
- Port Lx: SAE #6 (9/16th - 8UNF-2B)
- Ports BMRD, BMBS, VAGRx: SAE #8 (3/4 - 16UNF-2B)
- Ports BAGRx, TARGx, VAGRx: 1: SAE #8 (3/4 - 16UNF-2B)
- Port Px: SAE #16 (1-5/16th - 12UN-2B)
- Port T: SAE #20 (1-5/8th - 12UN-2B)
- 3/8" - 16UNC-28 x .75 DP Full Thread (4 Places)
- Cartridge Valve: 20 F-Lbs (Items # 5,6,7,12)
- Cartridge Valve: 25 F-Lbs (Items # 1,5,9,15)
- Cartridge Valve: 35 F-Lbs (Items # 13)
- Cartridge Valve: 45 F-Lbs (Items # 14)
- Cartridge Valve: 50 F-Lbs (Items # 10)
- Cartridge Valve: 100 F-Lbs (Items # 11)
- Cartridge Valve: 150 F-Lbs (Items # 8)
- Coil Hex: 5 F-Lbs

ORI Orifice Disc Accessible Under SV4

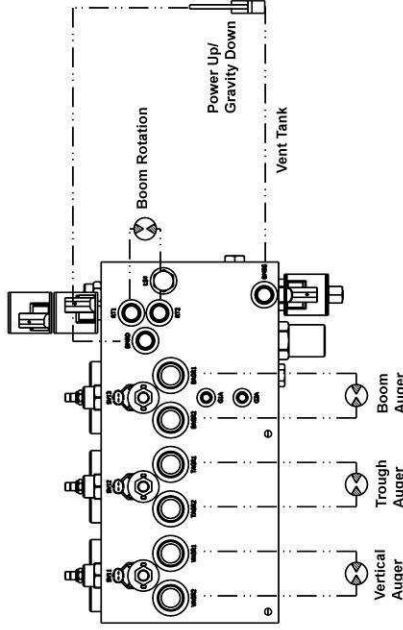

THIS DOCUMENT CONTAINS PROPRIETARY INFORMATION AND IT SHALL NOT BE USED OR REPRODUCED OR ITS CONTENTS DISCLOSED IN WHOLE OR IN PART WITHOUT THE PRIOR WRITTEN CONSENT OF WALINGA INC.

ALL DIMENSIONS ARE SHOWN IN INCHES UNLESS OTHERWISE SPECIFIED

ASSEMBLY WEIGHT: 92.5 LBS

DRAWN DATE: 02-JUN-14

DRAWING NUMBER: 59-67389-6

REVISION: SHEET NUMBER: 1 OF 3

DRAWING TITLE: HOAG MANIFOLD - ASSEMBLY

8.17 HYDRAULIC MANIFOLD SCHEMATICS (Cont'd)

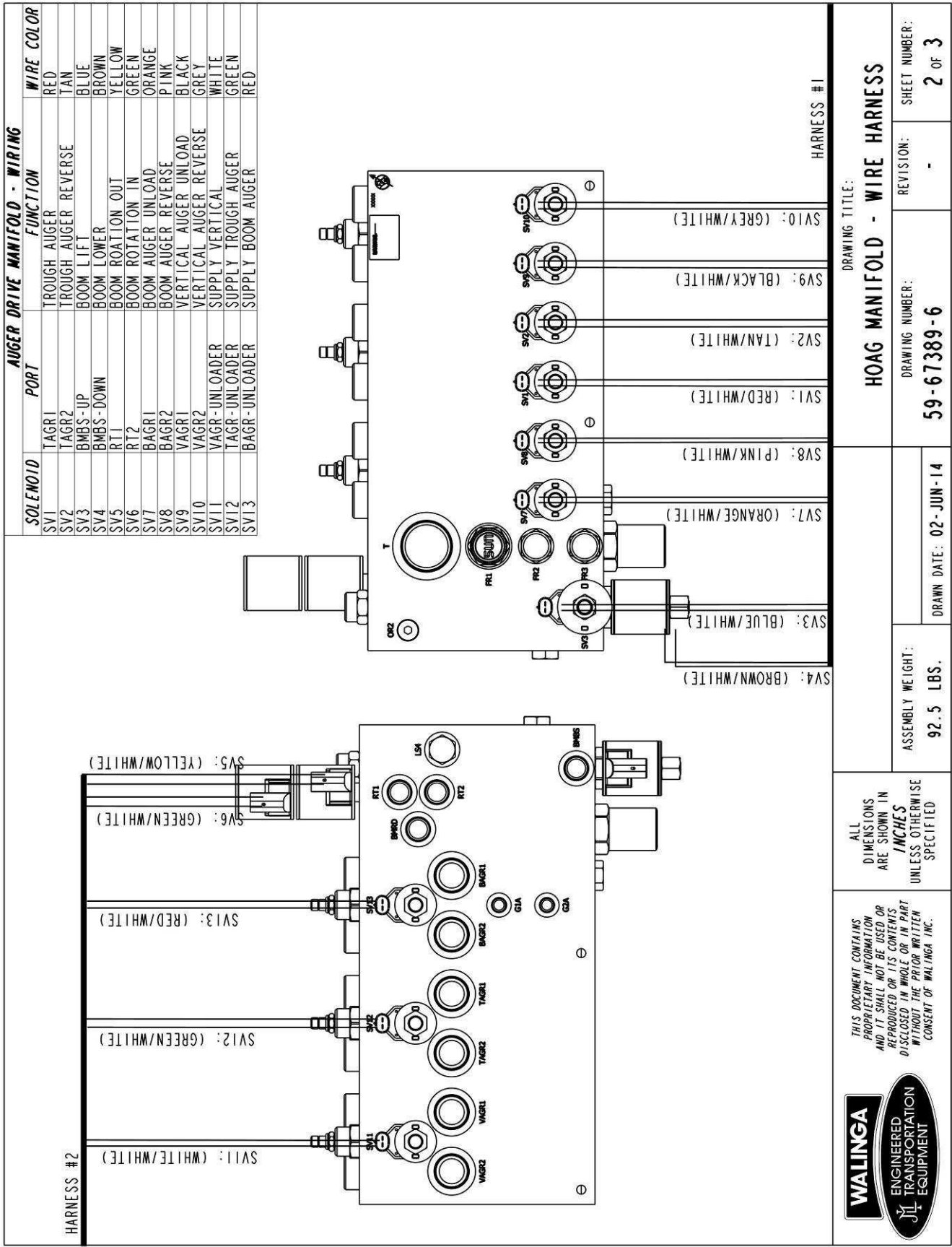

THIS DOCUMENT CONTAINS PROPRIETARY INFORMATION AND IT SHALL NOT BE USED OR REPRODUCED IN WHOLE OR IN PART WITHOUT THE PRIOR WRITTEN CONSENT OF WALINGA INC.

ALL DIMENSIONS ARE SHOWN IN INCHES UNLESS OTHERWISE SPECIFIED

8.17 HYDRAULIC MANIFOLD SCHEMATICS (Cont'd)

BILL OF MATERIALS			SEAL KIT: 59-78443-6	PORT #
ITEM	QTY	NUMBER	DESCRIPTION	SEAL SUB-KIT #
1	2	59-65757-6	FLOW REGULATOR	FR2/FR3
2	9	59-73089-6	COIL	SV: 1, 2, 7-13
3	4	59-73091-6	COIL	SV: 3, 4, 5, 6
4	1	59-77718-6	SOLENOID	SV5/SV6
5	3	59-78439-6	SOLENOID	SV: 11, 12, 13
6	6	59-78440-6	SOLENOID	SV: 1, 2, 7-10
7	1	59-78442-6	FLOW REGULATOR	FRI
8	3	59-78447-6	RELIEF	RV: 1, 2, 3
9	6	59-92692-6	DIRECT	PD: 1-6
10	3	59-92693-6	SHUTTLE	LS: 2, 3, 4
11	1	59-92695-6	LOGIC	BCI
12	1	59-92697-6	DIVIDER	FDI
13	1	59-92698-6	BRAKE RELEASE	LSI
14	1	59-92699-6	SOLENOID	SV: 3
15	1	59-96910-6	SOLENOID	SV: 4

WALINGA
ENGINEERED TRANSPORTATION EQUIPMENT

THIS DOCUMENT CONTAINS PROPRIETARY INFORMATION AND IT SHALL NOT BE USED, REPRODUCED OR ITS CONTENTS DISCLOSED IN WHOLE OR IN PART WITHOUT THE PRIOR WRITTEN CONSENT OF WALINGA INC.

ALL DIMENSIONS ARE SHOWN IN INCHES UNLESS OTHERWISE SPECIFIED

ASSEMBLY WEIGHT: 92.5 LBS.

DRAWN DATE: 02-JUN-14

DRAWING NUMBER: 59-67389-6

REVISION: -

SHEET NUMBER: 3 OF 3

DRAWING TITLE: HOAG MANIFOLD - WIRE HARNESS

8.18 GATE TOWER - MANUAL

Each compartment is equipped with a gate that controls the flow of material into the trough conveyor. Each gate is opened and closed manually with a crank or with an air cylinder.

For units built prior to 1999, (see figure 8-40) the tracking chain must be positioned snugly against the sprocket to prevent tooth jumping or jamming. To adjust the tracking chain, follow this procedure:

1. Stop engine and remove ignition key.
2. Enter compartment and remove cover over tower.
3. Loosen jam nut on tracking chain position bolt.
4. Use the position nut to properly locate the tracking chain against the sprocket.
5. Tighten jam nut to its specified torque.



WARNING

Machine is shown with guard removed or access door opened for illustrative purposes only. Do not operate machine with guard removed or access door opened.

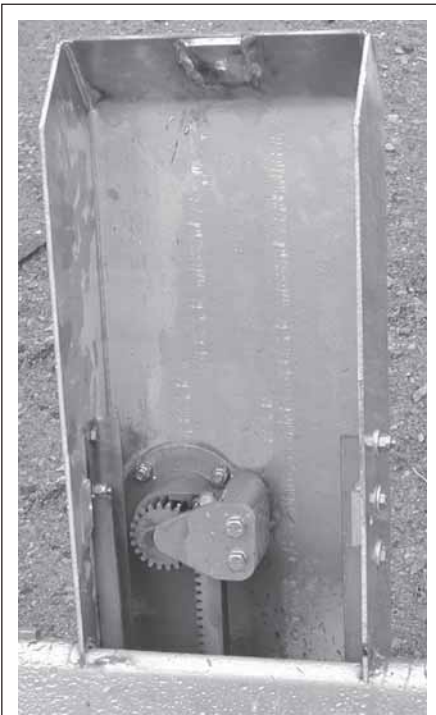
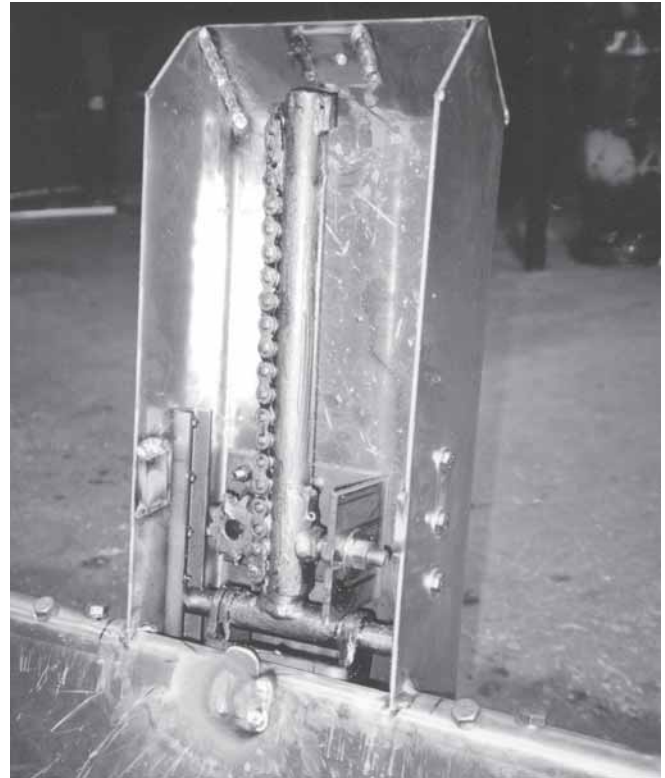

Fig. 8-40A NEW STYLE MANUAL GATE (ON UNITS BUILT AFTER 1999)



Tower



Tracking Chain Position Bolt

Fig. 8-40 MANUAL GATE

9 BOOM ROTATION DRIVE SYSTEM

Each unit is equipped with a boom that can be rotated into position for unloading. A dual stage roller chain drive system provides an infinitely variable system for positioning the boom to any feed storage facility. For the system to function as required, the roller chain must be lubricated monthly and the chain tension maintained at the proper level.

To set chain tension, follow this procedure:

1. Place all controls in neutral, disengage PTO clutch, stop engine, set park brake, remove ignition key and wait for all moving parts to stop.
2. Remove guards over boom rotation drive system.
3. Check tension of each chain. With the proper tension, the chain can deflect 1/8 inch (3 mm) at the centre of the span.
4. **To adjust chain tension:**
 - a. Use the nut on the sprocket position bolt to set the position of the sprocket assembly.

NOTE

Always set the sprocket position first.

- b. Loosen the hydraulic motor assembly mounting bolts.
 - c. Slide or tap the motor assembly into the desired position.
 - d. Tighten motor assembly mounting bolts to their specified torque.
5. Install and secure the drive system guards.



WARNING

Machine is shown with guard removed or access door opened for illustrative purposes only. Do not operate machine with guard removed or access door opened.



Drive System



Sprocket Position Bolt



Hydraulic Motor Assembly

Fig. 9-1 BOOM ROTATION DRIVE SYSTEM

10 TROUBLE SHOOTING

The Walinga Bulk Feed Unit uses an auger, air or a dual system for unloading material as required. It is a simple and reliable system that requires minimal maintenance.

In the following section, we have listed many of the problems, causes and solutions to the problems that you may encounter.

If you encounter a problem that is difficult to solve, even after having read through this trouble shooting section, please call your local Walinga dealer or distributor. Before you call, please have this Operator's Manual and the serial numbers from your trailer ready.

PROBLEM	CAUSE	SOLUTION
1. Air Ride Suspension		
Trailer leans...		
...constantly in one direction	Suspension beams installed out of parallel.	Determine which beam is out of parallel, cut from axle, reposition and re-weld.
...varies from side to side.	Axle welds missing or broken.	Clear away old welds, reposition the beams to be parallel and re-weld to axle.
...varies in one direction.	Failed pivot bushing (rare).	Contact Hendrickson Turner Technical Service Department.
<hr/>		
Trailer "Dog-Tracks"...		
...constantly to one side.	Trailer out of alignment.	Remove weld from the alignment collars on those axles requiring adjustment. Realign per procedure provided by Hendrickson Turner.
...from side to side.	Missing or broken alignment collar welds.	Clear away failed welds and realign per procedure provided by Hendrickson Turner.
...to one side under load.	Suspension not square to axle.	Contact the Hendrickson Turner Technical Service Department.
	Air springs misaligned.	Compare the installation to the suspension drawing and reposition mountings as required.
	Failed pivot bushing (rare).	Contact the Hendrickson Turner Technical Service Department.

PROBLEM

CAUSE

SOLUTION

1. Air Ride Suspension (cont'd)

Bushing Walk

The suspension beams have shifted from the center of the pivot bushings).

Incorrect alignment.

Re-bush the suspension and re-align as per Hendrickson Turner instructions.

Suspension beams out of parallel (vertically or longitudinally).

Determine which beam(s) is out of position, cut from axle, reposition and weld. Re-bush both suspension pivots.

Frame bracket centers do not match the suspension beam centers.

Compare the installation dimensions to the suspension assembly drawing. Reposition the incorrect components and re-bush both suspension pivots.

Use of improper bushing lubricant.

Re-bush using lubricant supplied by Hendrickson Turner.

Pivot can be moved vertically.

Faulty or worn bushing.

Replace bushing.

Bushing protrudes from the bushing tube.

Failed bushing.

Rubber protruding from both ends of the bushing tube is normal. Excess rubber protruding from one end can indicate a bushing walk condition.

PROBLEM

CAUSE

SOLUTION

2. Mechanical Suspension

Improper suspension spring action.

Broken or cracked spring leaves.

Replace complete spring.

Uneven load distribution.

Rearrange load for proper distribution.

Weak spring.

Replace spring.

Springs out of alignment in hangers due to loose U-bolts.

Align springs and tighten U-bolts to proper torque.

PROBLEM

CAUSE

SOLUTION

3. Tires

	Over or under inflation.	Inflate to proper pressure.
	Loose wheel stud nuts or clamps.	Tighten wheel stud nuts or clamps.
	Loose or tight wheel bearing.	Adjust bearings.
	Axle bent or out of alignment.	Straighten, align or replace axle.
	Tires not properly matched.	Match tires.
	Improper acting brakes.	Correct brakes as required.
	Rapid stopping.	Apply brakes slowly when approaching stops.
	High speed.	Reduce speed.
<hr/>		
	Over or under inflation.	Inflate to proper pressure.
	Excessive speed on turns.	Reduce speed.
	Tire wobble due to uneven rim clamping.	Torque tighten all rim clamps.
	Worn or damaged wheel bearings.	Replace bearings.
	Bent wheel or rim.	Replace wheel or rim.
	Bent axle.	Replace or straighten axle.
<hr/>		
	Leaf spring broken.	Replace leaf or complete spring.
	Bent axle.	Replace or straighten axle.
	Frame or suspension (axles) out of alignment.	Straighten frame or align axles.
<hr/>		
Loss of tire air pressure.	Puncture in tire.	Repair or replace tire.
	Faulty valve or valve core.	Replace valve assembly or core.
	Wheel or rim damage.	Replace wheel or rim.

PROBLEM	CAUSE	SOLUTION
4. Electrical		
Lights flicker or do not come on.	Bad connection.	Check electrical system circuits.
	Frayed wires.	Repair as required.
	Battery on tractor not sufficiently charged.	Charge battery.
	Damaged or disconnected wire on ground cable.	Repair or replace cable.
	Poor ground at sockets.	Repair as necessary.
Complete loss of trailer lights.	Broken main harness.	Repair or replace.
	Junction box failure.	Replace junction box.
	Frayed wires.	Repair as required.
	Damaged or disconnected ground cable.	Repair or replace cable as required.
	Loose or corroded connection in ground lead between tractor and trailer.	Repair or replace.
Lights flash improperly or appear to be crossed.	Internal short in junction box.	Repair or replace junction box.

PROBLEM**CAUSE****SOLUTION****5. Air System**

Excessive compressor cycling.

Air leak.

Check air line fittings and hose connections on service or supply line.

Check service chamber at clamp housing, push rod for damage.

Check service chamber diaphragm.

Check emergency chamber clamp and vent holes for leakage.

Repair or replace air chamber as required.

Check FFVII brake valve if so equipped. Repair or replace as required.

Trailer brakes slow and sluggish.

System or component failure.

Check slack adjuster and chamber/spring brake push rod alignment for interference.

Assure slack adjuster and chamber/spring brake push rod angle 90° applied with proper adjustment.

Assure open lines - no kinks, bends, closed shut-off cocks, restrictions, excessive elbows.

Assure adequate tractor brake function.

Have authorized service center check for adequate pressure and timing balance relative to tractor/trailer application.

PROBLEM

CAUSE

SOLUTION

5. Air System (cont'd)

Trailer brakes drag.

System or component failure

Assure emergency line exceeds 120 psi pressure; check and maintain governor at max. cut-in.

Check slack adjuster and chamber/spring brake push rod alignment for interference.

Assure slack adjuster and chamber/spring brake push rod angle 90° applied with proper adjustment.

Assure open lines - no kinks, bends, closed shut-off cocks, restrictions, excessive elbows.

Check for trapped service air pressure at trailer service/delivery hoses. If air pressure is noted, check for full release of all application valves (tractor/truck/trailer).

Trailer brakes won't apply (service).

System or component failure.

Check air delivery to emergency system.

Check air delivery to service gladhand.

Check air delivery to air chamber or spring brake.

Check air delivery to all reservoirs at system working pressure.

Check slack adjuster and chamber/spring brake push rod alignment for interference.

Check slack adjuster and chamber/spring brake push rod angle 90° applied with proper adjustment.

Park/emergency brakes won't release.

System or component failure.

Check air jumper hoses are not crossed between tractor and trailer.

Check air delivery to emergency gladhands exceeds 120 psi.

Check air delivery to FFV valve.

Check air delivery to all reservoirs at system working pressure.

PROBLEM**CAUSE****SOLUTION****5. Air System (cont'd)**

Park/emergency brakes won't release (cont'd).

System or component failure (cont'd).

Check open lines - no kinks, bends, closed shut-off cocks, restrictions, excessive elbows.

Check that brake shoes are not frozen to drums.

Park/emergency brakes won't hold.

System or component failure.

Check slack adjuster and chamber/spring brake push rod alignment for interference.

Assure slack adjuster and chamber/spring brake push rod angle 90° applied with proper adjustment.

Air reservoir leaks or loose mounting.

System or component failure.

Replace/use rubber grommets with integral brackets.

Semi-trailer "Runs-Up" on tractor.

Check brake linkage.

Assure slack adjuster and chamber/spring brake push rod angle 90° applied with proper adjustment.

Check gladhand connection.

Assure open lines - no kinks, bends, closed shut-off cocks, restrictions, excessive elbows.

Have authorized service center check for adequate pressure and timing balance relative to tractor/trailer application.

Poor braking performance.

Uneven brakes.

Check slack adjuster and chamber/spring brake push rod angle 90° applied with proper adjustment.

Check open lines - no kinks, bends, closed shut-off cocks, restrictions, excessive elbows.

Check for leaks in system by applying service brake and inspecting.

PROBLEM

CAUSE

SOLUTION

5. Air System (cont'd)

Poor braking performance (cont'd).

Trailer brake lining wear excessive.

Have authorized service center check for adequate pressure and timing balance relative to tractor/trailer application.

Proceed per problem "trailer brakes drag."

Trailer brakes slow to apply.

Check slack adjuster and chamber/spring brake push rod angle 90° applied with proper adjustment.

Check air delivery to all reservoirs at system working pressure.

Check open lines - no kinks, bends, closed shut-off cocks, restrictions, excessive elbows.

Have authorized use of "jumper hose analyser" and duplex gauge to pin-point brake imbalance.

Check functional return spring in service chamber or spring brake.

Check open lines - no kinks, bends, closed shut-off cocks, restrictions, excessive elbows.

Trailer service brakes slow to release.

Have authorized use of "jumper hose analyser" and duplex gauge to pin-point brake imbalance.

Slack adjuster not auto-adjusting.

Check for damaged actuator rod. Replace as required.

Slack adjuster internal components seized. Replace.

Cracked housing.

Replace slack adjuster.

Worn clevis pin bushing.

Replace bushing

PROBLEM

CAUSE

SOLUTION

5. Air System (cont'd)

Poor braking performance (cont'd).

Full function valve (FFV) leaks at exhaust port with all brakes released.

Replace FFV valve.

Full function valve (FFV) leaks at exhaust port with service brakes applied.

Replace FFV valve.

Spring parking brake (service only service chamber side of spring brake) drags or won't release.

Check for:

- Improper adjustment, restriction or broken line.
- Diaphragm failure.
- System pressure too low (120 psi min).
- Replace entire unit or piggy-back emergency section.

Spring parking brake leaks when pressurized for park brake release.

Check for:

- Ruptured spring side diaphragm.
- Hose leaks.
- Repair hose leak or replace spring brake chamber.

PROBLEM	CAUSE	SOLUTION
6. Hydraulic System		
No oil pressure.	Hose hook up incorrect.	Reverse hoses on pump.
	Loose coupling in driveline.	Check setscrews in driveline.
	Loose connection.	Check hose fittings.
	Air in oil.	Check hose fittings.
Noisy pump.	Bent drive shaft.	Check driveline.
	Low oil supply.	Increase oil in reservoir.
	Air in oil.	Check hose fittings.
Discharge auger will not raise.	See if boom lock is released.	Check for air leaks.
	Low oil pressure.	PTO in jammed gear.
		Check line pressure at suggested RPM.
Vertical, discharge and floor augers running in reverse.	Wrong motor rotation after being repaired.	Switch oil lines.
Auger does not turn when motor is running.	Key in auger bushing is sheared.	Replace key.
	Motor shaft is broken.	Remove motor and check shaft.
Auger will not swivel when motor is running.	Broken chain.	Replace or repair chain.
	Key in motor shaft is sheared.	Replace key.
	Motor shaft is broken.	Remove motor and check shaft.
Extreme pressure needed to swivel discharge.	Lack of lubrication on pivot rings.	Lubricate pivot rings.
Discharge and floor auger exceedingly noisy.	Nylon lining worn or damaged.	Remove auger, check and repair worn nylon.
	Loose hanger bearing.	Tighten bearing.
Evidence of oil in feed.	Leaking oil seal on boom auger or vertical auger motor.	Remove motor and replace seal.

PROBLEM	CAUSE	SOLUTION
7. Orbit Motor		
Slow operation.	Plugged filter.	Replace filter element or clean filter.
	Relief setting too low.	Set relief valve for proper PSI.
	Worn pump.	Repair or replace pump.
	Worn motor.	Replace worn parts or motor.
	Extremely high fluid temperature causing pump and motor to slip (temp. increase as pump and motor wear).	Increase reservoir size and use a high viscosity index such as 20W40.
	Inadequate size oil lines.	Increase oil lines.
	Pump cavitation.	Increase oil line size to pump, in cold weather, use 5W20 oil.
Motor will not turn.	Shaft seized in housing due to excessive side load or misalignment (Note 500 lb. max. radial loading on shaft).	Replace housing assembly set if damaged.
	Large contaminating particles in fluid such as machining chips or sand - very dirty fluid.	Flush new systems - use better filtration.
	Broken shaft from extreme side loads or misalignment.	Correct and replace.
Motor runs without turning shaft.	Broken shaft.	Replace shaft assembly - check housing for wear and replace if necessary.
Motor turns in wrong direction after being replaced.	Hose connections wrong.	Reverse connections.
Leak at shaft.	Worn or cut quad-ring.	Replace quad-ring, polish shaft at seal area with #600 wet or dry sanding cloth.

PROBLEM	CAUSE	SOLUTION
7. Orbit Motor (cont'd)		
Leak between flange and housing.	Loose flange.	Tighten.
	Damaged seal between housing flange.	Replace seal. Check housing surface at seal for sharp nicks or deep scratches.
	Leak in body plug seal.	Replace faulty o-rings.
<hr/>		
Leak between housing and wear plates or between wear plates and gerotor.	End cap bolts loose. (Note: All motors are tested and rated of a maximum back pressure of 1000 PSI).	Tighten the cap screws at gerotor end of motor - if the threads are accidentally stripped in the housing, the hole may be drilled and tapped deeper and the motor reassembled w/longer bolts.
<hr/>		
Leak between gerotor and end cap.	Dirt between surfaces.	Reassemble - clean and dry parts.
	Scratches or nicks on surfaces.	Polish very carefully on a flat, hard surface - use #600 or finer abrasive cloth and very little pressure - avoid rounding edges.
<hr/>		
Cracked front flange.	Use installation bolts which are too long and bottom against housing.	Replace flange and use proper size bolts.
<hr/>		
Leak at oil ports.	Poor fittings.	Replace fittings carefully.
	Damaged threads.	Replace housing or use nut such as true seal.

PROBLEM

CAUSE

SOLUTION

8. Hydraulic Failures

a. Cavitation.

Insufficient inlet flow.

Wrong pump speed. Slow down engine RPM and pump speed.

System hoses too small. Replace hoses with larger size.

Tank below line inlet. Change inlet to bottom of tank.

Pressure hose used as suction hose. Intake hose too small. Increase size of intake line.

Detergent oil in hydraulic system. Drain and flush hydraulic system. Replace with specified (non-detergent) oil.

Air getting into system (aeration). Tighten all fittings and extend return line outlet below fluid surface in reservoir.

Suction filters restricting flow. Replace all filters and clean all screens.

Clogged or inadequate breather. Clean or replace breather.

Wrong oil for climatic conditions. Change to proper oil.

Poor tank construction. Replace with better tank.

Abused by overspeeding. Replace pump and don't overspeed.

PROBLEM

CAUSE

SOLUTION

8. Hydraulic Failures (cont'd)

a. Cavitation (cont'd).

Contamination

Condensation in system and tank. Drain and flush system. Fill with specified oil. Increase frequency of changing oil.

Inclement weather. Allow system to warm before operating.

Poor tank construction. Replace with better tank.

Incorrect material for piping (galvanized). Replace all piping. Use steel. Drain and flush system. Replace with clean oil.

Dirty environment. Change oil and filters more frequently.

Poor handling of oil. Only use clean containers to store and transport oil. Filter oil before adding to system.

Clogged or by-passing filter. Replace filter and change filters more frequently.

Sabotage. Keep unit in locked and controlled environment.

Cavitation contaminants. Replace pump. Drain and flush system. Replace with specified oil.

Stuck relief valve. Clean or replace

PROBLEM

CAUSE

SOLUTION

8. Hydraulic Failures (cont'd)

b. System exceeds pressure specifications over-heats.

Worn bearings: Cracks and discoloration.

Warped wear plates or pressure balance plates.

Internal seal destruction: Varnish deposits.

Extreme gear path cutout/ragged and rough edges.

Heat checked or discolored gears.

Components seize.

Housing cracks.

valve.

Running without oil. Do not run without oil or with low oil.

Requirements for cooler disregarded. Install cooler.

Leaving PTO in gear. Always disengage PTO when there is no demand for oil.

System operating at or above relief setting for extended period.

Change operating procedure to reduce pressure requirements.

Replace oil and damaged components.

Hoses have too many fittings and too many angles. Replumb system to reduce fittings and angles.

Poor reservoir design, placement or paint. Install new reservoir in a new place.

Indirect line routing. Replumb system to improve routing.

Poor hose construction. Replace with better hoses.

Improper hose selection. Replace with better hoses.

Lack of proper maintenance. Improve and increase maintenance frequency.

Restrictions in system from poor design and/or improper component selection. Review system design and change components as required.

11 SPECIFICATIONS

Model No.	Cubic Capacity Based on 44 cu. ft./ft.	No. of Compartments Size of Compartments	Base Unit Weight lbs/kg
HA-20-UL	880	Five (48")	10,611/4813
HA-24-UL	1056	Six (48")	11,351/5149
HA-28-UL	1232	Seven (48")	12,091/5485
HA-32-UL	1408	Eight (48")	12,831/5823
HA-34-UL	1496	Eight (51")	13,161/5970
HA-36-UL	1584	Eight (54")	13,485/6117
HA-36-UL	1584	Nine (48")	13,571/6156
HA-38-UL	1672	Eight (57")	13,809/6264
HA-38-UL	1672	Nine (48")	13,895/6303
HA-40-UL	1760	Ten (48")	14,305/6489
HA-40-UL	1760	Eight (60")	14,133/6411

SPECIFICATIONS SUBJECT TO CHANGE WITHOUT NOTICE

11.2 BOLT TORQUE

CHECKING BOLT TORQUE

The tables shown below give correct torque values for various bolts and capscrews. Tighten all bolts to the torques specified in chart unless otherwise noted. Check tightness of bolts periodically, using bolt torque chart as a guide. Replace hardware with the same strength bolt.

ENGLISH TORQUE SPECIFICATIONS

Bolt Diameter "A"	Bolt Torque*					
	SAE 2 (N.m) (lb-ft)		SAE 5 (N.m) (lb-ft)		SAE 8 (N.m) (lb-ft)	
1/4"	8	6	12	9	17	12
5/16"	13	10	25	19	36	27
3/8"	27	20	45	33	63	45
7/16"	41	30	72	53	100	75
1/2"	61	45	110	80	155	115
9/16"	95	60	155	115	220	165
5/8"	128	95	215	160	305	220
3/4"	225	165	390	290	540	400
7/8"	230	170	570	420	880	650
1"	345	225	850	630	1320	970

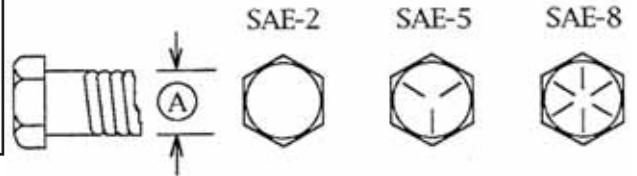

METRIC TORQUE SPECIFICATIONS

Bolt Diameter "A"	Bolt Torque*			
	8.8 (N.m) (lb-ft)		10.9 (N.m) (lb-ft)	
M3	.5	.4	1.8	1.3
M4	3	2.2	4.5	3.3
M5	6	4	9	7
M6	10	7	15	11
M8	25	18	35	26
M10	50	37	70	52
M12	90	66	125	92
M14	140	103	200	148
M16	225	166	310	229
M20	435	321	610	450
M24	750	553	1050	774
M30	1495	1103	2100	1550
M36	2600	1917	3675	2710

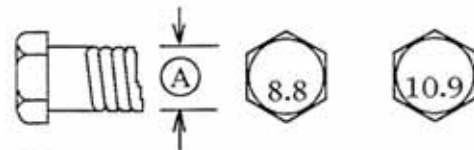

Torque figures indicated above are valid for non-greased or non-oiled threads and heads unless otherwise specified. Therefore, do not grease or oil bolts or capscrews unless otherwise specified in this manual. When using locking elements, increase torque values by 5%.

* Torque value for bolts and capscrews are identified by their head markings.

11.3 HYDRAULIC FITTING TORQUE

TIGHTENING FLARE TYPE TUBE FITTINGS *

1. Check flare and flare seat for defects that might cause leakage.
 2. Align tube with fitting before tightening.
 3. Lubricate connection and hand tighten swivel nut until snug.
 4. To prevent twisting the tube(s), use two wrenches. Place one wrench on the connector body and with the second tighten the swivel nut to the torque shown.
- * The torque values shown are based on lubricated connections as in reassembly.

	Tube Size OD (in.)	Nut Size Across Flats (in.)	Torque Value*		Recommended Turns To Tighten (After Finger Tightening)	
			(N.m)	(lb-ft)	(Flats)	(Turn)
	3/16	7/16	8	6	1	1/6
	1/4	9/16	12	9	1	1/6
	5/16	5/8	16	12	1	1/6
	3/8	11/16	24	18	1	1/6
	1/2	7/8	46	34	1	1/6
	5/8	1	62	46	1	1/6
	3/4	1-1/4	102	75	3/4	1/8
	7/8	1-3/8	122	90	3/4	1/8

TIGHTENING O-RING FITTINGS *

1. Inspect O-ring and seat for dirt or obvious defects.
2. On angle fittings, back the lock nut off until washer bottoms out at top of groove.
3. Hand tighten fitting until back-up washer or washer face (if straight fitting) bottoms on face and O-ring is seated.
4. Position angle fittings by unscrewing no more than one turn.
5. Tighten straight fittings to torque shown.
6. Tighten while holding body of fitting with a wrench.

	Tube Size OD (in.)	Nut Size Across Flats (in.)	Torque Value*		Recommended Turns To Tighten (After Finger Tightening)	
			(N.m)	(lb-ft)	(Flats)	(Turn)
	3/8	1/2	8	6	2	1/3
	7/16	9/16	12	9	2	1/3
	1/2	5/8	16	12	2	1/3
	9/16	11/16	24	18	2	1/3
	3/4	7/8	46	34	2	1/3
	7/8	1	62	46	1-1/2	1/4
	1-1/16	1-1/4	102	75	1	1/6
	1-3/16	1-3/8	122	90	1	1/6
	1-5/16	1-1/2	142	105	3/4	1/8
	1-5/8	1-7/8	190	140	3/4	1/8
	1-7/8	2-1/8	217	160	1/2	1/12

- * The torque values shown are based on lubricated connections as in reassembly.

12.0 HOAG AUGER TRAILER REPLACEMENT PARTS

PART #	TROUGH AUGER
96-71822-6	SF2 3/16" Bearing Rear Drive Trough
96-02388-6	HD Thrust Bearing Front
14-71880-6	Spacer Plastic For Under Bearing
62-08969-6	TG475MSO51AAAA Splined Motor 62-80969-6 Painted
14-48171-4	Splined Steel Nitrided Insert
15-27163-4	Idler Shaft Floor Auger
14-45435-4	Motor Shaft With Spline
14-37485-4	Shaft Split Hanger Bearing
96-18144-6	Bearing Wooden Round
14-39477-4	Split Bearing Half No Post
14-39908-4	Split Bearing Half Trough
28-03886-6	Steel Compression Spring Motor Mount
14-64574-6	UHMW Trough Liner 12" Trough
96-65439-6	2-1/4" 4 Bolt Bearing Front Drive Spline Motor
14-98462-5	Trough Hanger Bearing Assembly
	<p>VERTICAL AUGER</p> <p>14-07485-4 Motor Plate</p> <p>62-64286-6 TGO195MSO51AAAA Splined Motor 62-78436-6 Painted</p> <p>96-71822-6 Bearing 4 Bolt 2-3/16" Bottom Drive</p> <p>14-71880-6 Spacer Plastic For Under Bearing</p> <p>96-71821-6 Bearing 4 Bolt 2" Top</p> <p>28-03886-6 Steel Compression Spring Motor Mount</p> <p>96-17154-6 Seal V-32-A Nitrided For Motor Protection</p> <p>14-02998-4 VA Idler Shaft 2"</p> <p>14-45435-4 Auger Motor Shaft 13T For Drive</p> <p>14-29295-4 Motor Shaft With Key Way</p> <p>14-48171-4 Splined Steel Nitrided Insert</p> <p>14-64653-6 Wear Liner 15 VA Upright Bottom</p> <p>14-64545-4 Wear Liner 15 VA Top</p> <p>14-47981-4 Split Ring Half</p> <p>14-47980-4 Split Ring Flange</p> <p>14-88291-4 15VA Cylinder Lug</p>
	<p>BOOM ROTATION STANDARD</p> <p>14-28389-5 Gear Assembly 814/572 Large Sprocket Rotation</p> <p>96-07025-6 Sprocket Bushing For 14-28389-5</p> <p>97-15842-6 Sprocket 80 B12 11/4" 5/16 Key</p> <p>62-15777-6 ME 475 Key Shaft Motor TG0475MS031AAAA 62-78437-6 Painted</p> <p>97-17156-6 RC 50 Chain 10'</p> <p>97-17157-6 RC 50 Connector Link</p> <p>97-17280-6 RC 80 Chain 72 Pitch</p> <p>97-16313-6 RC 80 Connector Link</p>
	<p>BOOM ROTATION BRAKE MOTOR OPTION</p> <p>97-36660-4 Sprocket Splined Motor</p> <p>62-18711-6 Brake Motor 625 Splined BG0625AS050AAAB</p> <p>14-42061-5 Bracket Motor</p> <p>14-74995-4 Tension Bracket</p> <p>59-16303-6 Shuttle Valve</p>

12.0 HOAG AUGER TRAILER REPLACEMENT PARTS (Cont'd)

PART #	BOOM AUGER
62-64286-6	TGO195MSO51AAAA Motor 62-78436-6 Painted
14-48171-4	Splined Steel Nitrided Insert
96-71822-6	Bearing 4 Bolt 2-3/16"
96-71821-6	Bearing 4 Bolt 2"
59-04181-6	4x20 Boom Cylinder
14-39477-4	Split Berg Half No Post
14-39409-4	Horizontal Split Bearing Half Long
14-39543-4	Horizontal Split Bearing Half Short
14-64694-4	Hanger Bearing Spacer 1"
14-64695-4	Hanger Bearing Spacer 1-1/2"
96-18144-6	Bearing Wooden Round Housing 2-9/32" X 2"
28-03886-6	Spring Compression X 4
14-71880-6	Spacer Plastic For Under Bearing
14-37485-4	Shaft Split Hanger Bearing
86-85930-6	Hoag Boom Saddle
96-13553-6	Boom End Cap Bearing (Option Removable End)
80-65085-6	Hoag Boom Sock Standard
80-94235-6	Tapered Hoag Boom Sock (Option)
14-88517-5	12" BA Assembly 30' Galvanized Complete
14-88317-4	Boom Cylinder Lug Outside
14-88318-4	Boom Cylinder Lug Inside
52-13860-6	ROOF LIDS
15-04515-6	4"X4" Air Cylinder
52-60340-6	Hand Operated Flipper Air Valve
52-18364-6	Air Line Lubricator
	Air Valve 12V Pilot Operated (Optional)
52-16292-6	SAFETY RAIL
15-02315-6	Push Pull Air Valve Safety Rail
	4X9 Air Cylinder
15-04515-6	AIR GATES
15-02315-6	Hand Operated Flipper Air Valve
	4X9 Air Cylinder

13 INDEX

B	PAGE
Boom Rotation Drive System	125
I	
Introduction	9
O	
Operation Guidelines	21
Break-In	23
Controls	31
Hooking Up/Unhooking	28
Hooking Up	28
Unhooking	30
Machine Placement	36
Operation	39
Optional Equipment	52
Pre-Operation Vehicle Inspection	
Procedure	25
Terminology	22
To the New Operator or Owner	21
Transporting	49
Breaking Guidelines	50
Operating Instructions	49
Tires	51
P	
Periodic Maintenance and Adjustments	75
ABS Vehicle Control System	112
ABS Schematics	114
Air Chamber/Spring Brake	101
Air System	110
Air System Functional	110
Air System Inspection	110
Air System Schematic	111
Axle Alignment	79
Brakes	89
Electrical System	115
Electrical Schematics	116
Fifth Wheel	78
Gate Tower Manual	124
Hydraulic Schematics	117
King Pin and Fifth Wheel Plate	77
Slack Adjusters	92
Rockwell Automatic	92
Manual and Automatic Maintenance ...	93
Tires	87
Tire Wear Patterns	108
Torque Specification Summary	75

P	PAGE
Suspension System	102
Air Ride Suspension	102
Mechanical Suspension	106
Suspension System Schematics	107
Wheels	85
Wheel Hubs/Bearings	81
S	
Safety	10
General Safety	11
Hydraulic Safety	13
Maintenance Safety	13
Operating Safety	12
Safety Signs	14
Sign-Off Form	15
Tire Safety	14
Travel Safety	14
Unloading Safety	12
Safety Sign Locations	16
Service and Maintenance	54
Service	54
Fluids and Lubricants	54
Greasing	54
Hydraulic System	55
Specifications	141
Bolt Torque	142
Hydraulic Fitting Torque	143
T	
Trailer Servicing Intervals	56
Servicing Record Summary (Lubrication) ..	67
Trouble Shooting	126
U	
Unloading System Servicing	68
Service Intervals	68
Service Record	74

MANUAL COMMENT FORM

We would appreciate your input in helping us to provide you the customer, with improved manuals. Please use this form to submit Comments, Errors, Omissions, and Suggestions on this Manual. We would like your comments on things you do not like about this manual, as well as things you do like about the manual.

Please send this form via mail/e-mail or fax to Walinga Inc., or forward it to the closest Walinga Dealer or Sales Representative. Thank you for your comments.

MANUAL NO. 34-_____ -6.

PAGE NO. _____

PAGE NO. _____

PAGE NO. _____

ADDITIONAL COMMENTS: _____

CUSTOMER INFORMATION:

COMPANY NAME: _____

CONTACT NAME: _____

STREET ADDRESS: _____

CITY: _____ STATE: _____

COUNTRY: _____ POSTAL CODE: _____

PHONE NO: ____ - ____ - _____ FAX NO: ____ - ____ - _____

E-MAIL: _____ @ _____

SEND TO: Walinga Inc.(519) 824-5651
Marketing Department
RR# 5 Guelph Ontario
Canada, N1H 6J2



WALINGA[®]
INC.

Head Office:
RR#5
Guelph, Ontario, N1H 6J2
PHONE (888) 925-4642
FAX (519) 824-5651
www.walinga.com

FACTORY DISTRIBUTION AND SERVICE CENTRES:

IN CANADA:

- 70 3rd Ave. N.E. Box 1790 Carman, Manitoba Canada R0G 0J0
Tel (204) 745-2951 Fax (204) 745-6309

IN USA:

- 1190 Electric Ave. Wayland, MI. USA 49348
Tel (800) 466-1197 Fax (616) 877-3474
- 579 4th Street NW
Sioux Center, Iowa USA 51250
Tel (800) 845-5589 Fax (712) 722-1128

PRINTED IN CANADA
ISSUE DATE: March, 2012 rev. 07/14
High Output Auger Unload Manual

OM PART# 34-852276 v1.2 4242018