



Home Generator Systems

Operator's Manual



Home Generator System

Thank you for purchasing this quality-built Briggs & Stratton home generator. We're pleased that you've placed your confidence in the Briggs & Stratton brand. When operated and maintained according to the instructions in this manual, your home generator will provide many years of dependable service.

This manual contains safety information to make you aware of the hazards and risks associated with home standby generators and how to avoid them. Because we do not necessarily know all the applications this equipment could be used for, it is important that you read and understand these instructions thoroughly before attempting to start or operate this equipment. **Save these original instructions for future reference.**

This home generator requires professional installation before use. Refer to the separate installation manual for full information. Your installer should follow the instructions completely.

Where to Find Us

You never have to look far to find Briggs & Stratton support and service for your generator. Consult your Yellow Pages. There are thousands of Briggs & Stratton authorized service dealers worldwide who provide quality service. You can also contact Technical Service by phone at **800 743-4115**, or click on Find a Dealer at BRIGGSandSTRATTON.COM, which provides a list of authorized dealers.

Generator and engine model and serial numbers should be recorded in the installation manual.

Not
for
Reproduction

Briggs & Stratton Power Products Group, LLC
P.O. Box 702
Milwaukee, WI 53201-0702

Copyright © 2011. All rights reserved. No part of this material may be reproduced or transmitted in any form without the express written permission of Briggs & Stratton Power Products Group, LLC.

Table of Contents

Important Safety Instructions	4
Installation	7
Owner Orientation	7
Fuel Factors	8
Delivery Inspection	10
Controls	11
Generator	11
System Control Panel	12
Access Ports	13
Operation	15
Engine Oil	15
Battery	15
15 Amp Fuse	15
Automatic Operation	15
Maintenance	16
Fault Detection System	16
Generator Maintenance	18
Engine Maintenance	19
Engine Oil	19
Battery	24
Troubleshooting	26
Warranty	29
Limited Warranty	29
Warranty Period	29
About Your Warranty	30
Generator Specifications	31
Engine Specifications	31
Common Service Parts	31

Save These Instructions

Important Safety Instructions

SAVE THESE INSTRUCTIONS - This manual contains important instructions that should be followed during installation and maintenance of the generator and batteries.

Safety Symbols and Meanings



Explosion



Fire



Electrical Shock



Toxic Fumes



Rotating Parts



Hot Surface



Auto Start



Explosive Pressure



Chemical Burn



Lift Hazard



Read Manual

▲ The safety alert symbol indicates a potential personal injury hazard. A signal word (DANGER, WARNING, or CAUTION) is used with the alert symbol to designate a degree or level of hazard seriousness. A safety symbol may be used to represent the type of hazard. The signal word NOTICE is used to address practices not related to personal injury.

▲ DANGER indicates a hazard which, if not avoided, *will* result in death or serious injury.

▲ WARNING indicates a hazard which, if not avoided, *could* result in death or serious injury.

▲ CAUTION indicates a hazard which, if not avoided, *could* result in minor or moderate injury.

NOTICE addresses practices not related to personal injury.

The manufacturer cannot possibly anticipate every possible circumstance that might involve a hazard. The warnings in this manual, and the tags and decals affixed to the unit are, therefore, not all-inclusive. If you use a procedure, work method or operating technique that the manufacturer does not specifically recommend, you must satisfy yourself that it is safe for you and others. You must also make sure that the procedure, work method or operating technique that you choose does not render the generator system unsafe.

▲ WARNING Running engine gives off carbon monoxide, an odorless, colorless, poison gas.



Breathing carbon monoxide could result in death, serious injury, headache, fatigue, dizziness, vomiting, confusion, seizures, nausea or fainting.

- Operate this product **ONLY** outdoors in an area that will not accumulate deadly exhaust gas.
- Keep exhaust gas away from any windows, doors, ventilation intakes, soffit vents, crawl spaces, open garage doors or other openings that can allow exhaust gas to enter inside or be drawn into a potentially occupied building or structure.
- Carbon monoxide detector(s) **MUST** be installed and maintained indoors according to the manufacturer's instructions/recommendations. Smoke alarms cannot detect carbon monoxide gas.

▲ WARNING The engine exhaust from this product contains chemicals known to the State of California to cause cancer, birth defects, or other reproductive harm.

▲ WARNING Certain components in this product and related accessories contain chemicals known to the State of California to cause cancer, birth defects, or other reproductive harm. Wash hands after handling.

▲ WARNING Storage batteries give off explosive hydrogen gas during recharging.



Slightest spark will ignite hydrogen and cause explosion, resulting in death, serious injury, and/or

property damage.

Battery electrolyte fluid contains acid and is extremely caustic.

Contact with battery contents will cause severe chemical burns.

A battery presents a risk of electrical shock and high short circuit current.

- DO NOT dispose of battery in a fire. Recycle battery.
- DO NOT allow any open flame, spark, heat, or lit cigarette during and for several minutes after charging a battery.
- DO NOT open or mutilate the battery.
- Wear protective goggles, rubber apron, rubber boots and rubber gloves.
- Remove watches, rings, or other metal objects.
- Use tools having insulated handles.

 **WARNING** Generator produces hazardous voltage. Failure to properly ground generator could result in electrocution. Failure to isolate generator from utility power could result in death or serious injury to electric utility workers due to backfeed of electrical energy.

- When using generator for backup power, notify utility company.
- DO NOT touch bare wires or bare receptacles.
- DO NOT use generator with electrical cords which are worn, frayed, bare or otherwise damaged.
- DO NOT handle generator or electrical cords while standing in water, while barefoot, or while hands or feet are wet.
- If you must work around a unit while it is operating, stand on an insulated dry surface to reduce the risk of a shock hazard.
- DO NOT allow unqualified persons or children to operate or service generator.
- In case of an accident caused by electrical shock, immediately shut down the source of electrical power and contact the local authorities. **Avoid direct contact with the victim.**
- Despite the safe design of the generator, operating this equipment imprudently, neglecting its maintenance or being careless can cause possible injury or death.
- Remain alert at all times while working on this equipment. Never work on the equipment when you are physically or mentally fatigued.
- Before performing any maintenance on the generator, disconnect the battery cable indicated by a **NEGATIVE, NEG** or (-) first. When finished, reconnect that cable last.
- After your system is installed, the generator may crank and start without warning any time there is a power failure. To prevent possible injury, always set the generator's system switch to **OFF**, remove the service disconnect from the disconnect box AND remove the 15 Amp fuse BEFORE working on the equipment.

 **WARNING** Propane and Natural Gas are extremely flammable and explosive, which could cause burns, fire or explosion resulting in death, serious injury and/or property damage.

- DO NOT operate the equipment if the "fuel shut-off" valve is missing or inoperative.
- Install the fuel supply system according to NFPA 37 and other applicable fuel-gas codes.
- Before placing the generator into service, the fuel system lines must be properly purged and leak tested.
- After the generator is installed, you should inspect the fuel system periodically.
- NO leakage is permitted.
- DO NOT operate engine if smell of fuel is present or other explosive conditions exist.
- DO NOT smoke around the generator. Wipe up any oil spills immediately. Ensure that no combustible materials are left in the generator compartment. Keep the area near the generator clean and free of debris.

 **WARNING** Starter and other rotating parts can entangle hands, hair, clothing, or accessories resulting in serious injury.

- NEVER operate generator without protective housings, covers, or guards in place.
- DO NOT wear loose clothing, jewelry or anything that may be caught in the starter or other rotating parts.
- Tie up long hair and remove jewelry.
- Before servicing, remove 15 Amp fuse from control panel and disconnect **Negative (NEG or -)** battery cable.

▲ WARNING Exhaust heat/gases could ignite combustibles or structures resulting in death, serious injury and/or property damage. Contact with muffler area could cause burns resulting in serious injury.



- DO NOT touch hot parts and AVOID hot exhaust gases.
- Allow equipment to cool before touching.
- Exhaust outlet side of weatherproof enclosure must have at least 5 ft. (1.5 m) minimum clearance from any structure, shrubs, trees or any kind of vegetation.
- Standby generator weatherproof enclosure must be at least 5 ft. (1.5 m) from windows, doors, any wall opening, shrubs or vegetation over 12 inches (30.5 cm) in height.
- Standby generator weatherproof enclosure must have a minimum of 5 ft. (1.5 m) overhead clearance from any structure, overhang or trees.
- DO NOT place weatherproof enclosure under a deck or other type of structure that may confine airflow.
- Use only flexible fuel line provided. Connect provided fuel line to generator, DO NOT use with or substitute any other flexible fuel line.
- Smoke detector(s) MUST be installed and maintained indoors according to the manufacturer's instructions/recommendations. Carbon monoxide alarms cannot detect smoke.
- Keep at least minimum distances shown in *General Location Guidelines* to insure for proper generator cooling and maintenance clearances.
- It is a violation of California Public Resource Code, Section 4442, to use or operate the engine on any forest-covered, brush-covered, or grass-covered land unless the exhaust system is equipped with a spark arrester, as defined in Section 4442, maintained in effective working order. Other states or federal jurisdictions may have similar laws.
Contact the original equipment manufacturer, retailer, or dealer to obtain a spark arrester designed for the exhaust system installed on this engine.
- Replacement parts must be the same and installed in the same position as the original parts.

▲ CAUTION Installing the 15A fuse could cause the engine to start at any time without warning resulting in minor or moderate injury.



- Observe that the 15 Amp fuse has been removed from the control panel for shipping.
- DO NOT install this fuse until all plumbing and wiring has been completed and inspected.

▲ CAUTION Excessively high operating speeds could result in minor injury and/or equipment damage. Excessively low speeds impose a heavy load on generator.

- DO NOT tamper with governed speed. Generator supplies correct rated frequency and voltage when running at governed speed.
- DO NOT modify generator in any way.

NOTICE Improper treatment of generator can damage it and shorten its life.

- Use generator only for intended uses.
- If you have questions about intended use, contact your authorized dealer.
- Operate generator only on level surfaces.
- Adequate, unobstructed flow of cooling and ventilating air is critical to correct generator operation.
- The Oil Fill, Oil Drain and the Control Panel doors must be installed whenever the unit is running.
- DO NOT expose generator to excessive moisture, dust, dirt, or corrosive vapors.
- Despite the safe design of the generator, operating this equipment imprudently, neglecting its maintenance or being careless can cause possible injury or death.
- Remain alert at all times while working on this equipment. Never work on the equipment when you are physically or mentally fatigued.
- DO NOT start engine with air cleaner or air cleaner cover removed.
- DO NOT insert any objects through cooling slots.
- DO NOT use the generator or any of its parts as a step. Stepping on the unit can cause stress and break parts. This may result in dangerous operating conditions from leaking exhaust gases, fuel leakage, oil leakage, etc.
- If connected devices overheat, turn them off and disconnect them from generator.

Shut off generator if:

- electrical output is lost;
- equipment sparks, smokes, or emits flames;
- unit vibrates excessively;
- unit makes unusual noises.

Installation

We sincerely appreciate your patronage. For this reason, we have made every effort to provide for a safe, streamlined and cost-effective installation. Because each installation is unique, it is impossible to know of and advise the trade of all conceivable procedures and methods by which installation might be achieved. Neither could we know of possible hazards and/or the results of each method or procedure.

For these reasons, **only current licensed electrical and plumbing professionals should attempt generator system installations. Installations must strictly comply with all applicable codes, industry standards and regulations.**

Your generator is supplied with this "Operator's Manual" and a separate "Installation Manual". These are important documents and should be retained by the owner after the installation has been completed.

For the Home Owner:

To help you make informed choices and communicate effectively with your installation contractor(s), **read and understand *Owner Orientation* in this manual before contracting or starting your generator installation.**

To arrange for proper installation, contact the store at which you purchased your generator, your dealer, a licensed electrician or your utility power provider.

The generator warranty is VOID unless the system is installed by licensed electrical and plumbing professionals.

Every effort has been made to ensure that information in this manual is accurate and current. However, we reserve the right to change, alter, or otherwise improve the product and this document at any time without prior notice.

The Emission Control System for this generator is warranted for standards set by the U.S. Environmental Protection Agency and by the California Air Resources Board (CARB).

For the Installing Dealer/Contractor:

For most applications, the installation manual contains all the information required to properly install and start the generator. This operator's manual describes routine operation and owner maintenance procedures.

If you need more information in this matter, please call at 877-369-9400 between 8:00 AM and 5:00 PM CT.

Owner Orientation

This section provides generator owners with the information necessary to achieve the most satisfactory and cost effective installation possible.

The illustrations are for typical circumstances and are meant to familiarize you with the installation options available with your generator. A thorough understanding of these options will provide fundamental control over the cost of your installation, as well as ensure your final satisfaction and security.

Federal and local codes, appearance, noise levels, fuel types, and distances are the factors that must be considered when negotiating with an installation professional. Remember that as the distance from the existing electrical service and gaseous fuel supply increases, and the number of 90 degree bends in the fuel supply increases, compensations in piping and wiring materials must be made. This is necessary to comply with local codes and overcome electrical voltage drops and gaseous fuel pressure drops.

The factors mentioned above will have a direct affect on the overall price of your generator installation.

In some areas you may need to acquire electrical permits for installing the generator, building permits for installing gas lines, and permits for noise allowances. Your installer should check your local codes AND obtain the permits before installing the system.

Fuel Factors

An important consideration affecting the entire installation is the type of fuel used by your generator. The system was factory tested and adjusted using either natural gas or liquid propane (LP vapor). For proper engine function, factors that are inherent to each of these fuels, your location and the duration of possible utility interruptions are important considerations in the following fuel guidelines:

- Use clean, dry fuel, free of moisture or any particulate material. Using fuels outside the following recommended values may cause performance problems.
- In engines set up to run on propane (LP), commercial grade HD5 propane with a minimum fuel energy of 2500 BTUs/ft³ with maximum propylene content of 5% and butane and heavier gas content of 2.5% and minimum propane content of 90%.

Natural gas rating will depend on specific fuel but typical derates are between 10 to 20% off the LP gas rating.

Natural gas or LP engines are certified to operate on natural or liquid propane gas. The emissions control system for this engine is EM (Engine Modifications).

WARNING



Propane and Natural Gas are extremely flammable and explosive, which could cause burns, fire or explosion resulting in death, serious injury and/or property damage.

- The residential generator is equipped with an automatic safety gas “fuel shut-off” valve.
- DO NOT operate the equipment if the “fuel shut-off” valve is missing or inoperative.

Power Decrease at High Altitude or High Temperature

Air density is less at high altitudes, resulting in less available engine power. Specifically, engine power will decrease 3.5% for each 1,000 feet (300 meters) above sea level and 1% for each 10° F (5.6°C) above 77°F (25°C). Make sure you and your installer consider these factors when determining total generator load.

Generator Location

The actual physical location of your generator has a direct affect on:

1. The amount of plumbing required to fuel your generator.
2. The amount of wiring required to control and connect your generator.

Specific location guidelines are discussed in the installation manual. Acquaint yourself with that information and confer with your installer. Be sure to ask how your site might affect installation costs and compliance with local codes and standards.

- Install generator outdoors in an area that will not accumulate deadly exhaust gas.
- DO NOT install generator where exhaust gas could accumulate and enter inside or be drawn into a potentially occupied building or structure.
- By law it is required in many states to have a Carbon Monoxide (CO) detector in operating condition in your home. Carbon monoxide detector(s) **(A)** MUST be installed and maintained indoors according to the manufacturer's instructions/recommendations. A CO monitor is an electronic device that detects hazardous levels of CO. When there is a buildup of CO, the monitor will alert the occupants by flashing visual indicator light and alarm. Smoke alarms cannot detect CO gas.

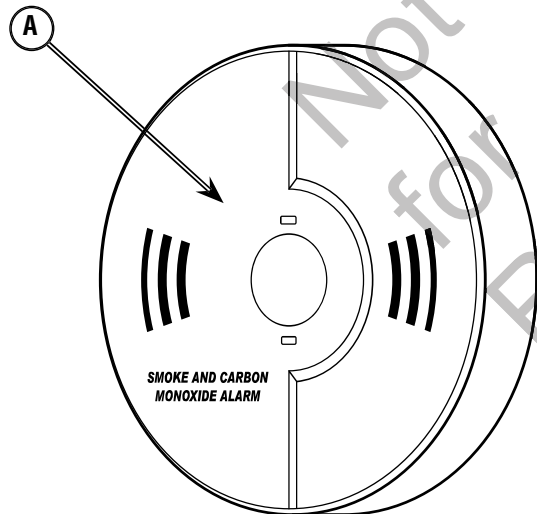

▲ WARNING Running engine gives off carbon monoxide, an odorless, colorless, poison gas.



- Breathing carbon monoxide could result in death, serious injury, headache, fatigue, dizziness, vomiting, confusion, seizures, nausea or fainting.
- Operate this product **ONLY** outdoors in an area that will not accumulate deadly exhaust gas.
 - Keep exhaust gas away from any windows, doors, ventilation intakes, soffit vents, crawl spaces, open garage doors or other openings that can allow exhaust gas to enter inside or be drawn into a potentially occupied building or structure.
 - Carbon monoxide detector(s) **MUST** be installed and maintained indoors according to the manufacturer's instructions/recommendations. Smoke alarms cannot detect carbon monoxide gas.

▲ WARNING Exhaust heat/gases could ignite combustibles or structures resulting in death, serious injury and/or property damage.



- Exhaust outlet side of weatherproof enclosure must have at least 5 ft. (1.5 m) minimum clearance from any structure, shrubs, trees, or any kind of vegetation.
- Standby generator weatherproof enclosure must be at least 5 ft. (1.5 m) from windows, doors, any wall opening, shrubs or vegetation over 12 in. (30.5 cm) in height.
- Standby generator weatherproof enclosure must have a minimum of 5 ft. (1.5 m) overhead clearance from any structure, overhang or trees.
- DO NOT place weatherproof enclosure under a deck or other type of structure that may confine airflow.
- USE **ONLY** flexible fuel line provided. Connect provided fuel line to generator. DO NOT use with or substitute any other flexible fuel line.
- Smoke detector(s) **MUST** be installed and maintained indoors according to the manufacturer's instructions/recommendations. Carbon monoxide alarms cannot detect smoke.
- DO NOT place weatherproof enclosure in manner other than shown in illustrations.

- Ensure exhaust gas is kept away from any windows, doors, ventilation intakes, soffit vents, crawl spaces, open garage doors or other openings that can allow exhaust gas to enter inside or be drawn into a potentially occupied building or structure. Your neighbor's home may be exposed to the engine exhaust from your standby generator and must be considered when installing your standby generator.
- Wind and air currents should be taken into consideration when positioning generator.

See the installation manual for full details on safe generator location.

Delivery Inspection

Carefully inspect the generator for any damage that may have occurred during shipment.

If loss or damage is noted at time of delivery, have the person(s) making delivery note all damage on the freight bill and affix his signature under the consignor's memo of loss or damage. If loss or damage is noted after delivery, separate the damaged materials and contact the carrier and your installer for claim procedures. Missing or damaged parts are not warranted.

The generator is supplied with:

- Pre-attached mounting pad
- Fully-serviced oil/lubricating system
- Flexible steel fuel line
- Installation and start-up manual
- Operator's manual
- Spare access door keys
- Spare 15A ATO type fuse
- Two pin control panel connector
- Ten pin control panel connector
- Lifting hole plugs (4)
- LP conversion jet
- Battery tie-down strap

Not included:

- Carbon monoxide detector(s)
- Smoke detector(s)
- Starting battery
- Connecting wire and conduit
- Fuel supply valves/plumbing
- Crane, lifting straps, chains or cables
- Two 48" lengths of 1" pipe (not conduit)
- Torque screwdriver, 50 to 50 inch-pound range
- Voltage / Frequency meter

Not
for
Reproduction

Controls

Generator



Read this Operator's Manual and Important Safety Instructions before operating your generator.

Compare the illustrations with your generator to familiarize yourself with the locations of various controls and adjustments. **Save this manual for future reference.**

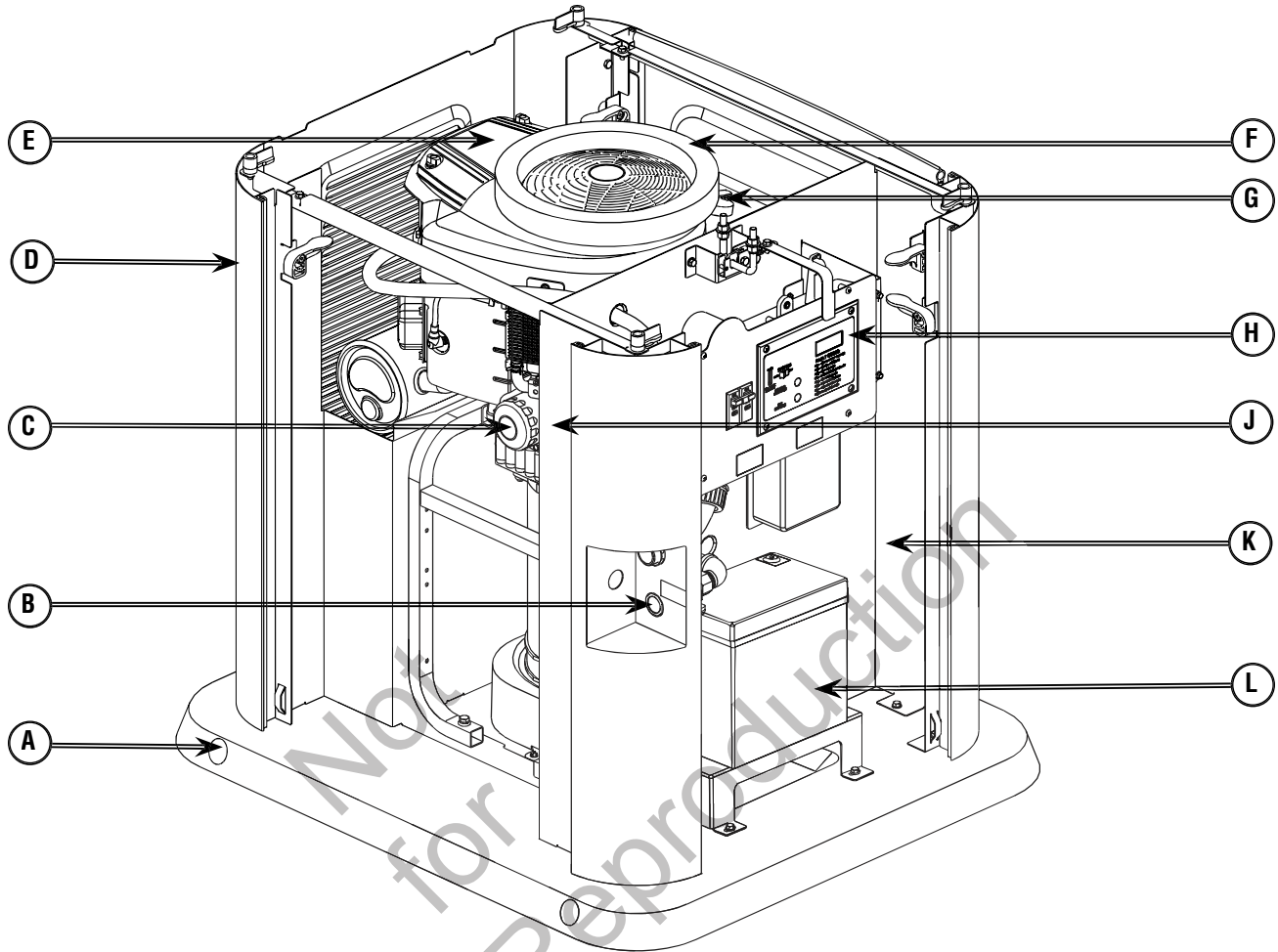

Generator is shown with roof and access covers removed for clarity.

A - Lifting Holes — Provided at each corner for lifting generator.

B - Fuel Inlet — Attach appropriate fuel supply to generator here.

C - Oil Filter — Filters engine oil to prolong generator life.

D - Exhaust Port — High-performance muffler lowers engine noise to comply with most residential codes.

E - Air Cleaner — Uses a dry type filter element and foam pre-cleaner to protect engine by filtering dust and debris out of intake air.

F - Engine Label — Located on engine valve cover. Identifies engine model and type.

G - Oil Fill Cap/Dipstick — Check and fill engine with recommended oil here.

H - Control Panel — Used for various test, operation and maintenance functions. See System Control Panel.

J - Oil Drain Hose — Located inside access panel, next to oil filter. Provided to facilitate oil changing.

K - Unit Identification Label — Identifies unit by serial number.

L - Battery (installer supplied) — 12 Volt DC, sealed battery provides power to start the engine.

System Control Panel

Compare this control panel illustration with your generator to familiarize yourself with the location of these important controls:

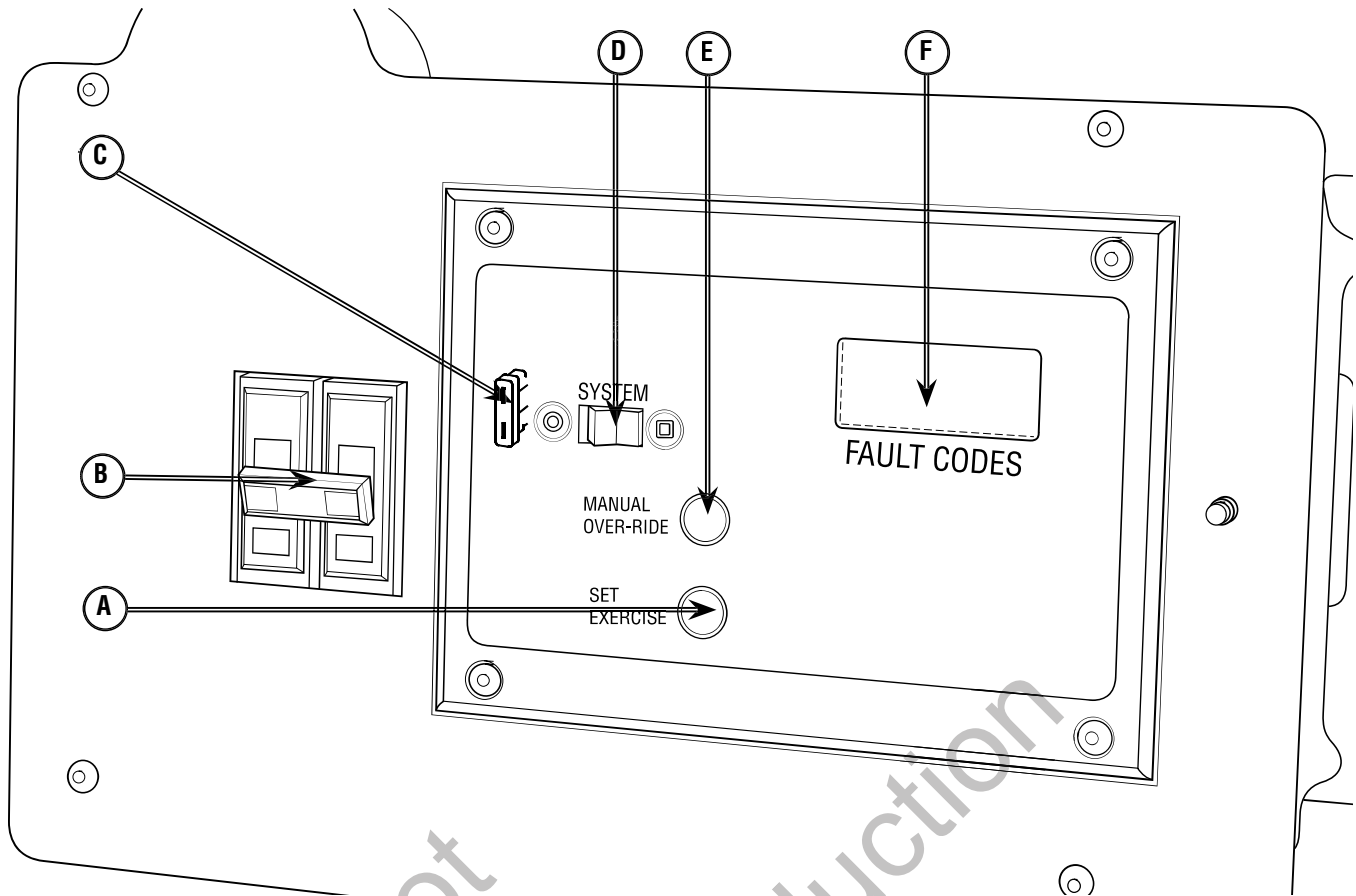

A - SET EXERCISE — Used to set the exercise cycle start time and day-of-the-week. Exercise cycle only occurs in **AUTO** mode.

B - Circuit Breaker — Protects the system from shorts and other over-current conditions. Must be **ON** to supply power to the Automatic Transfer Switch.

C - 15 Amp Fuse — Protects the generator DC control circuits. If the fuse has 'blown' (melted open) or was removed, the engine cannot crank or start. Replace the fuse using only an identical ATO 15A fuse.

D - System Switch — This two-position switch is the most important control on the system and is used as follows:

- “**AUTO**” position is the normal operating position. If a utility power outage is sensed, the system will start the generator. When utility power is restored, **AUTO** lets the engine stabilize internal temperatures, shuts off the generator, and waits for the next utility power outage.
- “**OFF**” position turns off running generator, prevents unit from starting and resets any detected faults.

E - MANUAL OVER-RIDE — With system switch in **AUTO** position, push the manual override switch to start the generator. To turn off the generator, push and hold the manual override switch again until engine stops.

F - Digital Display — Displays the total number of hours the generator has been running and fault codes. Used to schedule maintenance tasks and for troubleshooting operational problems with the generator. A constant number displayed indicates the total hours of operation. Fault conditions will flash “FC” followed by a fault code number. All fault conditions are described in *Fault Detection System*.

Access Ports

The generator is supplied with a set of identical keys. These keys fit the lock that secures the control panel access door.

To open access door:

1. Insert key into lock of access door and turn key one quarter turn counterclockwise.
2. Remove key.

To close access door:

1. Close control panel door and insert key into lock and turn key one quarter turn clockwise.
2. Remove key.

The generator is equipped with a removable roof and removable side panels to permit simple servicing.

To remove roof and divider:

1. Open the control panel access door.
2. Set generator's circuit breaker to **OFF** position.
3. Set control panel system switch to **OFF**.
4. Remove 15 Amp fuse from control panel.

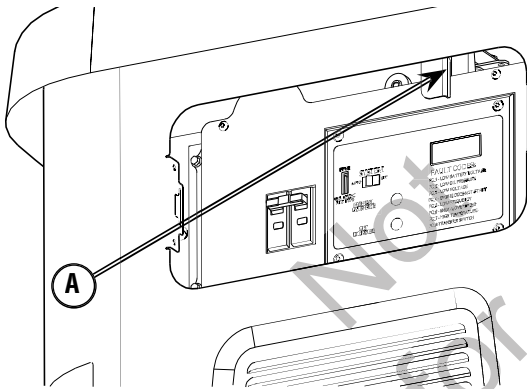

5. Move roof latch (A) to the left until roof pops up slightly.
6. Lift roof off of generator.
7. Rotate 4 knobs 1/4 turn and lift divider off.

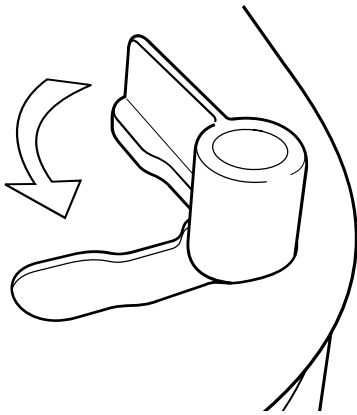

8. Replace divider and roof in reverse order.

To remove side panels:

1. Open the control panel access door.
2. Set generator's circuit breaker to **OFF** position.
3. Set control panel system switch to **OFF**.
4. Remove 15 Amp fuse from control panel.
5. Remove roof and divider.
6. Lift latches (B) up on both sides of panel to release.

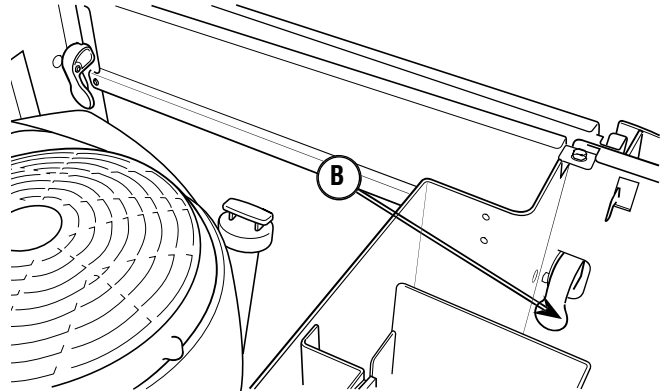

To remove exhaust panel:

1. Remove roof and divider.
2. Remove side panels.
3. Remove 6 screws (A) from exhaust panel.

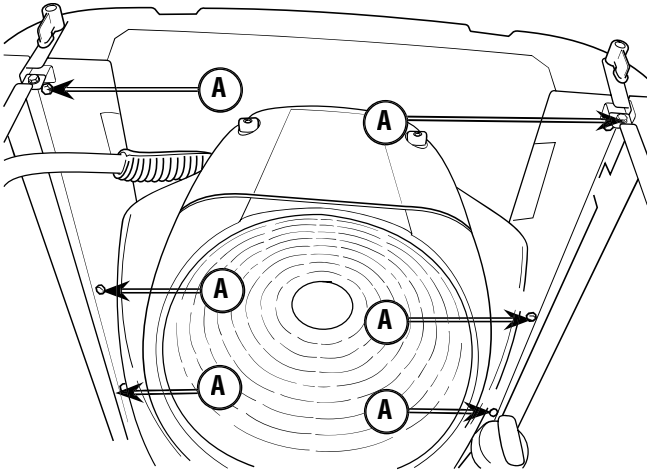

4. Pull exhaust panel up and out of base.

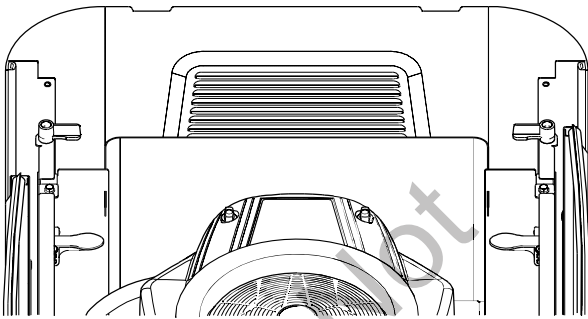

▲ WARNING Contact with muffler area could cause burns resulting in serious injury.



- DO NOT touch hot parts and AVOID hot exhaust gases.
- Allow equipment to cool before touching.

5. Remove two screws (B) and pull muffler cover off.

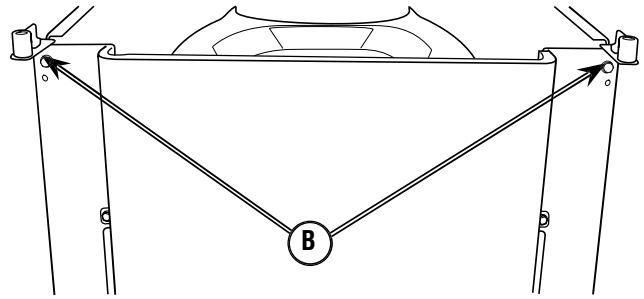

6. Replace muffler cover and exhaust panel in reverse order.

To install side panels:

1. Place panel in grooves and slide down in place.
2. Push latches (C) down on both sides of panel to lock into place.

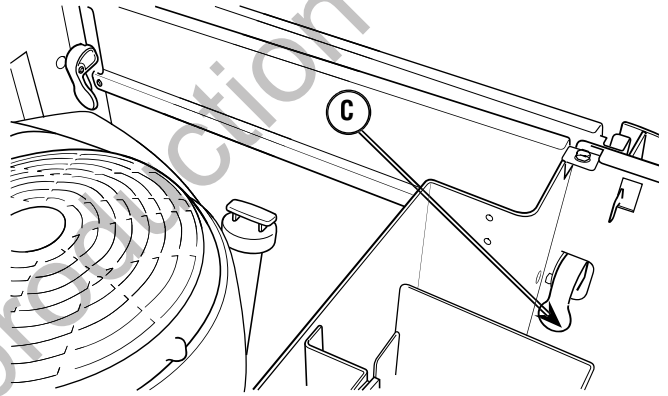

3. Replace divider and rotate knobs 1/4 turn to lock in place.

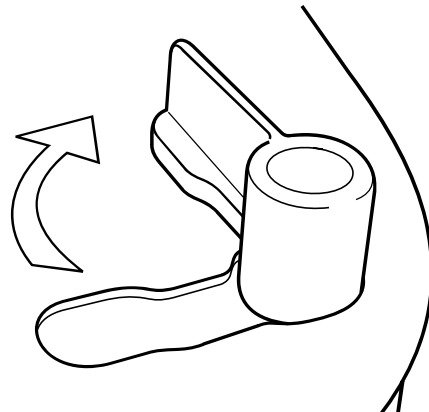

4. Replace roof.

Operation

Important Owner's Considerations

Engine Oil

NOTICE Any attempt to crank or start the engine before it has been properly serviced with the recommended oil will result in equipment failure.

- DO NOT attempt to crank or start the engine before it has been properly serviced with the recommended oil. This may result in an engine failure.
- Damage to equipment resulting from failure to follow this instruction will void generator warranty.

The engine is shipped from the factory pre-run and filled with synthetic oil (API SJ/CF 5W-30). This allows for system operation in a wide range of temperature and climate conditions. Before starting the engine, check oil level and ensure that engine is serviced as described in *Maintenance*.

Battery

The installer must supply a valve-regulated, rechargeable 12 volt DC starting battery. See *Battery in Final Installation Considerations* in the installation manual.

▲ WARNING Battery posts, terminals and related accessories contain lead and lead compounds, chemicals known to the State of California to cause cancer and reproductive harm. Wash hands after handling.

With the battery installed, all wiring to transfer switch and generator completed, utility power supplied to the automatic transfer switch, and the unit in **AUTO** mode, the battery receives a trickle charge while the engine is not running. The trickle charge cannot be used to recharge a battery that is completely discharged.

15 Amp Fuse

The generator's 15 Amp fuse is critical to correct system operation. The 15 Amp fuse was removed at the factory to prevent the unit from starting during shipping. Your installer will ensure the fuse is properly installed upon completion of the installation.

Automatic Operation

To select automatic operation, do the following:

1. Confirm 15 Amp fuse is installed in control panel.
2. Set the main distribution panel circuit breaker that sends utility voltage to the transfer switch to **ON**.
3. Set the generator's circuit breaker to its **ON** position.
4. Set the control panel system switch to **AUTO**.

▲ CAUTION With the system switch set to **AUTO**, the engine could crank and start at any time without warning, resulting in minor or moderate injury.

- To prevent possible injury that may be caused by such sudden starts, always set the system switch to **OFF** if performing maintenance on the system.
- Remove the 15 Amp fuse before working on or around the generator or transfer switch.

Checking Automatic Operation

To check the system for proper automatic operation, proceed as follows:

1. Set control panel system switch to **AUTO**.
2. Turn **OFF** the service disconnect or main distribution panel circuit breaker sending power to the automatic transfer switch.
When utility voltage is lost and the sensor has timed out, the engine will crank and start. Let the system go through its entire automatic operation sequence.
3. With the generator output supplying its loads, turn **ON** the service disconnect or main distribution panel circuit breaker that supplies utility power to the automatic transfer switch.
4. The automatic transfer switch will transfer loads back to utility power after a 5 minute minimum run time and utility power is available.
5. The generator will run for an additional one minute for engine cool down, then shut down.

If utility power is restored and generator does not shut down after 10 minutes, set system switch to **OFF** and contact your installer or local service center.

This completes the test procedures for automatic operation. The generator will now start automatically and will supply power to the transfer switch when utility power is lost.

Setting Exercise Timer

The generator is equipped with an exercise timer that will start and exercise the system once every seven days. During this exercise period, the unit runs for approximately 20 minutes and then shuts down. Electrical load transfer DOES NOT occur during the exercise cycle (unless an utility power outage occurs).

A button on the control panel is labeled “SET EXERCISE” (see System Control Panel). The specific day and the specific time of day this button is pressed is programmed into the control board memory. This date and time is then used to automatically initiate the system exercise cycle. The “SET EXERCISE” legend on the control panel will flash until the set exercise cycle is set.

To perform the Set Exercise procedure:

1. Choose the day and time you want your generator to exercise.
2. On that day and time, press and hold “SET EXERCISE” for three seconds.
The “Set Exercise” display will illuminate then turn off to confirm that the exercise timer has been set. Then release the button.
The unit will crank and run the exercise cycle. During the cycle, “Set Exercise” will illuminate.
Once the exercise cycle is complete, the unit will turn off and “Set Exercise” will no longer be displayed.
The exercise cycle may be discontinued at anytime by turning the System Switch to **OFF**.
3. The unit will then start and run it’s 20 minute exercise cycle weekly.

For example, if you press SET EXERCISE on Sunday morning at 10:00 AM, the unit will run an immediate exercise cycle and an exercise cycle every following Sunday at 10:00 AM (+/- 1/2 hour).

“Set Exercise” will only work if the unit is in the AUTO mode and this exact procedure is followed. The exerciser will need to be re-set if the 15 Amp fuse is removed or changed, or if the starting battery is disconnected.

If your want to change the day and time the unit exercises, simply perform the “Set Exercise” procedure at the exact weekday and time you want it to take place.

Generator will not exercise if timer is not set.

Maintenance

Servicing the System

Before performing any generator maintenance, always perform the following steps:

1. Set generator’s circuit breaker to its **OFF** position.
2. Set control panel system switch to **OFF**.
3. Remove 15 Amp fuse from control panel.
4. **Utility voltage is present at generator control panel.** Disconnect power before servicing control panel by removing the fuses from the transfer switch.
5. After all servicing has been completed, replace fuses in transfer switch, replace 15 Amp fuse in control panel, set system switch and circuit breaker **ON** and reset exercise timer. See *Setting Exercise Timer*.

Fault Detection System

The generator may have to run for long periods of time with no operator present. For that reason, the system is equipped with sensors that automatically shut down the generator in the event of potentially damaging conditions, such as low oil pressure, high temperature, over speed, and other conditions.

The generator’s control panel has a digital display that shows fault codes, like “FC_1”. The table below lists the detected fault and the fault code as it is displayed on the control panel.

Fault Description	Fault Codes
Low battery voltage	FC_1
Low oil pressure	FC_2
Low voltage	FC_3
Engine does not start	FC_4
Low frequency	FC_5
Engine overspeed	FC_6
High temperature	FC_7
Transfer switch fault	FC_8

The optional remote LED indicator can be installed at a convenient inside location. The LED will remain lit when the generator is in **AUTO**. Should a system fault be detected, the LED will turn on and off in a series of blinks that identify the problem. The blink pattern is repeated with a brief pause between each series of blinks.

Reset Fault Detection System

The operator must reset the fault detection system each time it activates. To do so, place the control panel system switch in the **OFF** position for 30 seconds or more. Remedy the fault condition, then return the generator to service by placing the system switch in the **AUTO** position, installing the 15 Amp fuse, and resetting the exercise timer. See *Setting Exercise Timer in Operation*.

A description of each fault and suggested remedies are as follows:

No LED - Discharged Battery

If there is a detected fault condition but the optional remote LED indicator is not blinking, this is because the battery is completely discharged. To remedy the problem, remove the 15 Amp fuse and disconnect the battery from the generator. Take the battery to a local battery store for analysis. Reinstall battery after it has been fully recharged, connecting the **NEGATIVE** cable last. Then reset the fault detection system, as described earlier.

Low Battery Voltage (FC_1)

This fault is indicated by fault code FC_1 and one blink on the optional remote LED indicator. This condition occurs if the generator cannot start because the starting battery output power is below that needed to crank the engine. Causes for this problem may be a faulty battery or battery charge circuit.

To remedy the problem, contact your local service center to check the battery charge output. Remove the 15 Amp fuse and disconnect the battery from the generator. Take the battery to a local battery store for analysis.

Reinstall the battery (replace if necessary - see *Battery in Final Installation Considerations* in the installation manual). Then reset the fault detection system, as described earlier.

Low Oil Pressure (FC_2)

This fault is indicated by fault code FC_2 and two blinks on the optional remote LED indicator. The unit is equipped with an oil pressure switch that uses normally closed contacts held open by engine oil pressure during operation. Should oil pressure drop below the 8 psi range, switch contacts close and the engine is shut down.

To remedy the low oil pressure condition, add the recommended oil to the FULL mark on the dipstick.

If the low oil pressure condition still exists, the engine will start, then shut down again. The fault code will appear and the LED will flash. In this case, contact an authorized dealer.

Low Voltage (Generator, FC_3)

This fault is indicated by fault code FC_3 and three blinks on the optional remote LED indicator. This condition is caused by a restriction in the fuel flow, a broken or disconnected signal lead, a failed alternator winding, the control panel circuit breaker is open, or the generator is overloaded.

To remedy the problem, contact your installer or an authorized dealer.

Engine Does Not Start (FC_4)

This fault is indicated by fault code FC_4 and four blinks on the optional remote LED indicator. This feature prevents the generator from damaging itself if it continually attempts to start in spite of another problem, such as no fuel supply. Each time the system is directed to start, the unit will crank for 10 seconds, pause for 10 seconds, and repeat. If the system does not begin producing electricity after approximately 2 minutes, the unit will stop cranking and the LED will blink.

Check to make sure the generator's circuit breaker is in the **ON** position in order for the sensing leads to verify that the unit is running.

The most likely cause of this problem is no fuel supply. Check the internal and external fuel shut off valves to ensure they are fully open. Other causes could be failed spark plug(s), failed engine ignition, or the engine air filter is clogged. You may need to contact your installer for assistance if you can't remedy these problems.

Low Frequency (FC_5)

This fault is indicated by fault code FC_5 and five blinks on the optional remote LED indicator. This feature protects devices connected to the transfer switch by shutting the generator down if the engine runs slower than 55 Hz for three seconds.

This condition is caused by a failed engine component or by excessive loads on the generator. To remedy the problem, contact your installer or an authorized dealer.

Engine Overspeed (FC_6)

This fault is indicated by fault code FC_6 and six blinks on the optional remote LED indicator. This feature protects devices connected to the transfer switch by shutting the generator down if the engine happens to run faster than the preset limit. The overspeed fault is detected as follows:

- If the generator output frequency is 65-70 Hz, after three seconds, the generator will shut down.
- If the generator output frequency is greater than 70 Hz, the generator will shut down immediately.

This condition is caused by a failed engine component. To remedy the problem, contact your installer or an authorized dealer.

High Temperature (FC_7)

This fault is indicated by fault code FC_7 and seven blinks on the optional remote LED indicator. The contacts of the temperature switch are normally open. If the engine temperature exceeds approximately 149°C (300°F), the fault is detected and the engine shuts down.

Common causes for this condition include running the unit with access doors removed, obstructed air inlet or exhaust port, low oil level, or debris in the engine cylinder cooling fins.

To resolve the problem, let the engine cool down and remove any accumulated debris and obstructions. Ensure that all access doors are installed whenever the unit is running.

Transfer Switch Fault (FC_8)

This fault is indicated by fault code FC_8 and eight blinks on the optional remote LED indicator (if transfer switch is equipped with fault detection).

The most likely cause of this fault is a blown fuse in the transfer switch. To remedy the problem, contact your installer or an authorized dealer.

Maintenance Schedule

Follow the hourly or calendar intervals of operation, whichever occurs first.

First 5 Hours
Change Engine Oil
Every 8 Hours or Daily
Clean Debris
Check Engine Oil Level
Every 100 Hours or Annually
Change Air Filter
Change Engine Oil and Filter
Replace Spark Plugs
Check Valve Clearance
Annually
Clean Air Cooling System
Check Fuel System
Check Exhaust System
Test System Operation (Simulate a Power Outage)

When all engine servicing is complete, replace 15 Amp fuse in control panel and reset the exercise timer. See *Setting Exercise Time in Operation*.

Regular maintenance will improve the performance and extend life of the generator. See any authorized dealer for service.

NOTICE Once a year you should replace the spark plugs and air filter. A new spark plug and clean air filter assure proper fuel-air mixture and help your engine run better and last longer.

Emissions Control

Maintenance, replacement, or repair of the emissions control devices and systems may be performed by any non-road engine repair establishment or individual.

However, to obtain “no charge” emissions control service, the work must be performed by a factory authorized dealer. See the *Emission Warranty*.

Generator Maintenance

The generator warranty does not cover items that have been subjected to operator abuse or negligence. To receive full value from the warranty, the operator must maintain the generator as instructed in this manual.

Some adjustments will need to be made periodically to properly maintain your generator.

All service and adjustments should be made at least once each season. Follow the requirements in the *Maintenance Schedule* chart.

Engine Maintenance

▲ WARNING Unintentional sparking could cause fire or electric shock resulting in death or serious injury.

WHEN ADJUSTING OF MAKING REPAIRS TO YOUR GENERATOR

- Disconnect the spark plug wire from the spark plug and place the wire where it cannot contact spark plug.

WHEN TESTING FOR ENGINE SPARK

- Use approved spark plug tester.
- DO NOT check for spark with spark plug removed.

Engine Oil

This engine is filled with synthetic oil (API SJ/CF 5W-30). This allows for system operation in the widest range of temperature and climate conditions.

We recommend the use of Briggs & Stratton Warranty Certified oils for best performance. Other high-quality detergent oils are acceptable if classified for service SF, SG, SH, SJ or higher. DO NOT use special additives.



NOTICE Synthetic oil meeting ILSAC GF-2, API certification mark of API service symbol with “SJ/CF ENERGY CONSERVING” or higher, is an acceptable oil at all temperatures. Use of synthetic oil does not alter required oil change intervals.

Changing Engine Oil



KEEP OUT OF REACH OF CHILDREN. DON'T POLLUTE. CONSERVE RESOURCES. RETURN USED OIL TO COLLECTION CENTERS.

Checking/Adding Engine Oil

1. Gain access to the dipstick on the engine.
2. Clean the oil fill area of any debris.
3. Remove the dipstick and wipe with a clean cloth.
4. Fully insert dipstick into oil fill.
5. Remove dipstick and check oil level. Verify oil is a FULL mark (top hole) on dipstick.

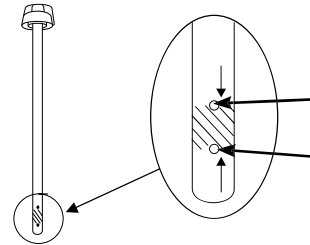

6. If needed, slowly pour recommended oil into oil fill opening. DO NOT overfill. After adding oil, wait one minute and recheck oil level.

NOTICE Overfilling with oil could cause the engine not to start, or hard starting.

- DO NOT overfill.
 - If over the FULL mark on dipstick, drain oil to reduce oil level to FULL mark on dipstick.
7. Replace and tighten oil dipstick.

▲ CAUTION Avoid prolonged or repeated skin contact with used motor oil.

- Used motor oil has been shown to cause skin cancer in certain laboratory animals.
- Thoroughly wash exposed areas with soap and water.

NOTICE Any attempt to crank or start the engine before it has been properly serviced with the recommended oil will result in equipment failure.

- Refer to the *Maintenance* section.
- Damage to equipment resulting from failure to follow this instruction will void engine and generator warranty.

Change oil while the engine is still warm from running, as described in the operator's manual.

1. Set control board system switch to **OFF**.
2. Remove 15 Amp fuse from control panel.
3. Place oil drain hose into an approved container.
4. Remove brass fitting from end of drain hose and drain oil into an approved container.
5. When oil has drained, replace brass fitting on hose.
6. Add oil if not changing oil filter, See *Checking/Adding Engine Oil*.

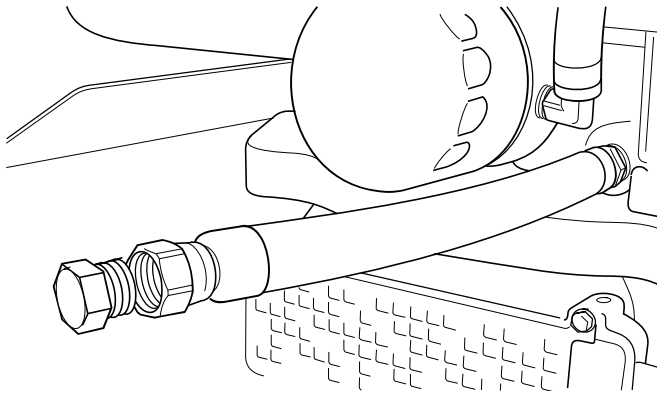

Changing Oil Filter

1. Place an approved container under oil filter.
2. Remove oil filter and dispose of properly.
3. Before installing a new oil filter, lightly lubricate the oil filter gasket with fresh, clean oil.
4. Install the oil filter by hand until the gasket contacts the oil filter adapter, then tighten the oil filter $\frac{1}{2}$ to $\frac{3}{4}$ turn.
5. Add oil as described in *Checking/Adding Engine Oil*.
6. Remove container from under oil filter and clean up any spilled oil.
7. Start and run engine. As engine warms up, check for oil leaks.
8. Stop engine, wait for oil to settle, check oil level and add if necessary as described in *Checking/Adding Engine Oil*.

NOTICE Any attempt to crank or start the engine before it has been properly serviced with the recommended oil will result in equipment failure.

DO NOT attempt to crank or start the engine before it has been properly serviced with the recommended oil. This may result in engine failure.

Damage to equipment resulting from failure to follow this instruction will void engine and generator warranty.

Not for Reproduction

Service Air Cleaner

Your engine will not run properly and may be damaged if you run it with a dirty air cleaner. Clean or replace more often if operating under dusty or dirty conditions.

NOTICE Do not use pressurized air or solvents to clean the filter. Pressurized air can damage the filter and solvents will dissolve the filter.

To service the air cleaner, follow these steps:

1. Loosen knobs and remove cover. Remove air cleaner by lifting the ends up and out.
2. To loosen debris, gently tap air cleaner on a hard surface. If air cleaner is excessively dirty, replace with a new air cleaner.
3. Install clean (or new) air cleaner inside base and push down until air cleaner snaps in place. See *Specifications*.
4. Reinstall cover and tighten knobs.

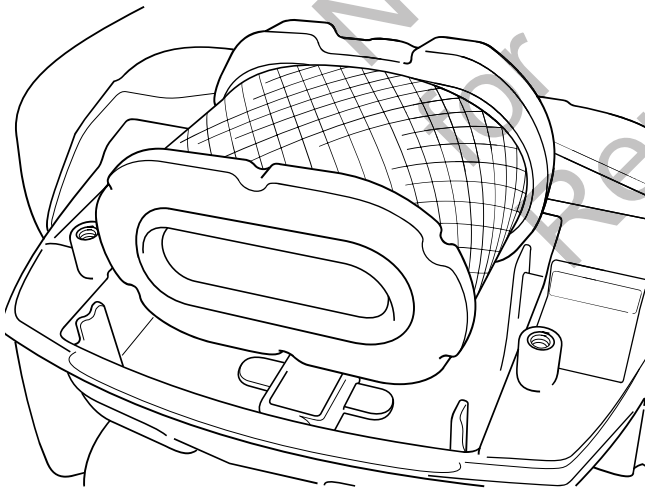
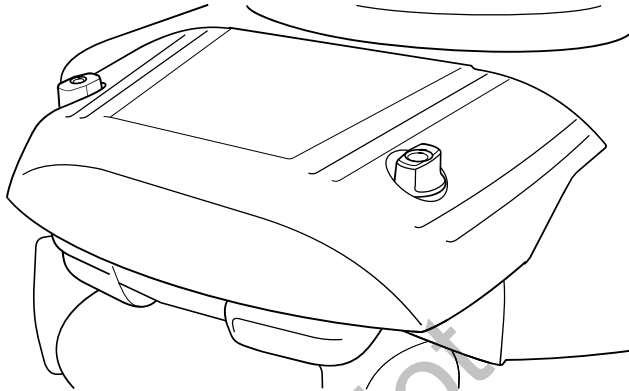

Service Spark Plugs

Changing the spark plugs will help your engine to start easier and run better.

1. Clean area around spark plugs.
2. Remove and inspect spark plugs.
3. Check electrode gap with wire feeler gauge and reset spark plug gap to recommended gap if necessary (see *Specifications*).
4. Replace spark plugs if electrodes are pitted, burned or porcelain is cracked, Use the recommended replacement spark plugs. (See *Specifications*).
5. Install spark plugs and tighten to 180 in.-lbs. (20 Nm).

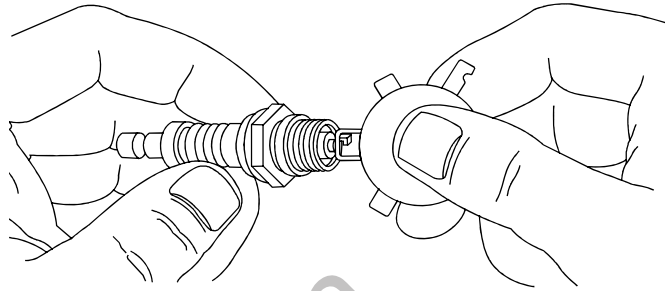

Check Valve Clearance

Regular valve clearance check and adjustment will improve performance and extend engine life. The procedure cannot be done without partial engine disassembly and the use of special tools. For this reason we recommend that you have an authorized Service Dealer check and adjust valve clearance at recommended intervals (see *Maintenance Schedule* in the *Maintenance* section).

Clean Air Cooling System

Generator maintenance consists of keeping the unit clean. Operate the unit in an environment where it will not be exposed to excessive dust, dirt, moisture or any corrosive vapors. Cooling air louvers on the enclosure must not become clogged with snow, leaves, or any other foreign material. To prevent generator damage caused by overheating, keep the enclosure cooling inlets and outlets clean and unobstructed at all times.

Check the cleanliness of the unit frequently and clean when dust, dirt, oil, moisture or other foreign substances are visible on its exterior/interior surface. Inspect the air inlet and outlet openings inside and outside the enclosure to ensure air flow is not blocked.

Over time debris may accumulate in cylinder cooling fins and cannot be observed without partial engine disassembly. Unobstructed air flow is critical for correct generator operation. For this reason, we recommend you have an authorized Service Dealer clean the cooling system per recommended intervals (see *Maintenance Schedule* in the *Maintenance* Section). Equally important is to keep top of engine free from debris. Make sure the oil cooler fins are free of dirt and debris.

NOTICE Improper treatment of generator could damage it and shorten its life.

- DO NOT use direct spray from a garden hose to clean generator. Water can enter the engine and generator and cause problems.
- DO NOT expose generator to excessive moisture, dust, dirt, or corrosive vapors.
- DO NOT insert any objects through cooling slots.

Clean the generator as follows:

1. Use a damp cloth to wipe exterior surfaces clean.
2. Use a soft, bristle brush to loosen caked on dirt, etc.
3. Use a vacuum cleaner to pick up loose dirt and debris.
4. Use low pressure air (not to exceed 25 psi) to blow away dirt. Inspect cooling air slots and openings in the generator. These openings must be kept clean and unobstructed.

Fuel System Inspection and Maintenance

Natural Gas/Propane Fuel System

The fuel system installed on this engine has been designed to various standards to ensure performance and reliability. To ensure compliance to these standards, follow the recommended maintenance schedule contained in this section.

NOTICE The fuel system components have been specifically designed and calibrated to meet the fuel system requirements of the engine. If a fuel system component fails to operate or develops a leak, it should be repaired or replaced with the OEM recommended replacement parts.

Pressure Regulator Maintenance and Inspection

- Check for any fuel leaks at the inlet and outlet fittings.
- Check for any fuel leaks in the regulator body.
- Check to ensure the regulator is securely mounted and the mounting bolts are tight.
- Check the regulator for external damage.

Venturi/Throttle Control Device Maintenance and Inspection

NOTICE A dirty air cleaner may significantly alter the venturi performance.

- Leaks at all fittings.
- Ensure the venturi and throttle body are securely mounted.
- Inspect air cleaner element according to the recommended maintenance schedule found in this section.
- Inspect air inlet hose connection and clamp. Inspect hose for cracking, splitting, or chaffing. Replace if any of these conditions exist,
- Check fuel line for cracking, splitting, or chaffing. Replace if any of these conditions exist.
- Check for leaks at the throttle body and intake manifold.

Exhaust System Maintenance and Inspection

When inspecting the exhaust system, check the following:

- Inspect exhaust manifold at the cylinder head for leaks and that all retaining bolts and shields (if used) are in place.
- Inspect muffler for exhaust leaks. Repair as necessary.

Test System Operation (Simulate a Power Outage)

Partial disassembly and special tools are required to accurately measure voltage output and frequency. For this reason we recommend you have an authorized Service Dealer test the system operation.

1. Set the generator's system switch to **OFF**.
2. Remove the 15 Amp fuse in control panel.
3. Remove four screws that hold circuit breaker cover to air intake guard.
4. Connect an accurate voltage and frequency meter to line side of generator's main circuit breaker.
5. Set generator's main circuit breaker to **ON** (closed) position.
6. Install 15 Amp fuse in control panel.
7. Set generator's system switch to **AUTO**.
8. Turn utility power **OFF**. Once the 10 second timer has expired, the engine will crank and start.
9. The transfer switch will transfer to Generator power.
10. Apply various loads to the generator and observe its performance.
11. Exercise the generator under varying loads for 30 minutes. Monitor the output voltage and frequency of the generator to verify it's performance is within specifications.
12. Turn utility power **ON**.
13. When the load is transferred back to the utility power source, the engine cool-down timer starts timing.
14. The generator will run for about one minute to cool down, then the generator will stop.

NOTE: Minimum engine run time is 5 minutes. If transfer back to utility occurs before 5 minutes the generator will still run for 5 minutes.

Battery

Servicing of batteries is to be performed or supervised by personnel knowledgeable of batteries and the required precautions. Keep unauthorized personnel away from batteries.

Servicing the Battery

If it is necessary to service the battery, proceed as follows:

1. Set control board system switch to **OFF**.
2. Remove 15 Amp fuse from control panel.
3. Service or replace battery as required. See *Battery* in *Final Installation Considerations* in the installation manual for specific battery needed.
4. Connect red battery cable to battery positive terminal (indicated by **POSITIVE, POS,** or **(+)**).
5. Connect the battery charge wire (wire #13) shown as **(A)** to the battery positive terminal (indicated by **POSITIVE, POS,** or **(+)**):

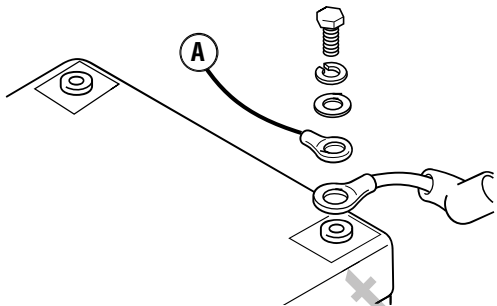

6. Connect black negative battery cable to negative battery terminal (indicated by **NEGATIVE, NEG,** or **(-)**).
7. Ensure hardware on both positive and negative battery terminals is secure.
8. Reinstall 15 Amp fuse in control panel.
9. Set generator's system switch to **AUTO**.
10. Reset exercise timer. See *Setting Exercise Timer*.



DON'T POLLUTE. CONSERVE RESOURCES. RETURN USED BATTERY TO RECYCLING COLLECTION CENTER.

Charging the Battery

If it is necessary to charge the battery, proceed as follows:

1. Set control board system switch to **OFF**.
2. Remove 15 Amp fuse from control panel.
3. Disconnect negative battery cable from negative battery terminal (indicated by **NEGATIVE, NEG,** or **(-)**).
4. Charge battery with battery charger at 2 Amps until battery holds 12 Volts. DO NOT exceed 13.7 volts when charging.

▲ WARNING Battery posts, terminals and related accessories contain lead and lead compounds, chemicals known to the State of California to cause cancer and reproductive harm. Wash hands after handling.

NOTICE Failure to disconnect negative battery cable will result in equipment failure.

- DO NOT attempt to jump start the generator.
- Damage to equipment resulting from failure to follow this instruction will void engine and generator warranty.

▲ WARNING Storage batteries give off explosive hydrogen gas during recharging. Slightest spark will ignite hydrogen and cause explosion, resulting in death, serious injury and/or property damage.



Battery electrolyte fluid contains acid and is extremely caustic. Contact with battery contents will cause severe chemical burns. A battery presents a risk of electrical shock and high short circuit current.

- DO NOT dispose of battery in a fire. Recycle battery.
- DO NOT allow any open flame, spark, heat, or lit cigarette during and for several minutes after charging a battery.
- DO NOT open or mutilate the battery.
- Wear protective goggles, rubber apron, rubber boots and rubber gloves.
- Remove watches, rings, or other metal objects.
- Use tools having insulated handles.

▲ CAUTION With the system switch set to **AUTO**, the engine could crank and start at any time without warning, resulting in minor or moderate injury.



- To prevent possible injury that may be caused by such sudden starts, always set the system switch to **OFF** if performing maintenance on the system.
- Remove the 15 Amp fuse before working on or around the generator or transfer switch.

When Calling for Assistance

You must have the following information at hand if it is necessary to contact a local service center regarding service or repair of this unit:

1. Obtain the unit Model Number and Serial Number from the unit ID label. See *Controls* for location of the label or refer to the information recorded on the inside from cover of the installation manual.
2. Obtain the engine identification numbers from the engine label. See the operator's manual for location of this information.

Storage

The Rheem/Ruud generator system is designed for continuous backup operational duty. There is no need to take any storage precautions. However, if it becomes necessary to take the system out of service for an extended period, call Technical Services at **877-369-9400**, between 8:00 AM and 5:00 PM CT for specific recommendations.

Not
for
Reproduction

Troubleshooting

Problem	Cause	Correction
Engine is running, but no AC output is available.	<ol style="list-style-type: none"> 1. Circuit breaker open or defective. 2. Fault in generator. 3. Poor wiring connections or defective transfer switch. 	<ol style="list-style-type: none"> 1. Reset or replace circuit breaker. 2. Contact local service facility. 3. Check and repair.
Engine runs good at no-load but “bogs down” when loads are connected.	<ol style="list-style-type: none"> 1. Short circuit in a connected load. 2. Generator is overloaded. 3. Shorted generator circuit. 4. Fuel Pressure is incorrect. 5. Natural gas fuel mixture is incorrect. 6. Kinked fuel line between regulator and engine. 	<ol style="list-style-type: none"> 1. Disconnect shorted electrical load. 2. Turn off one or more loads. 3. Contact local service facility. 4. See <i>Gaseous Fuel System</i> in the Installation Manual. 5. See <i>Gaseous Fuel System</i> in the Installation Manual. 6. Remove kink in fuel line. Replace if necessary.
Engine will not start; or starts and runs rough.	<ol style="list-style-type: none"> 1. 15 Amp fuse missing or blown. 2. Fuel supply turned off or depleted. 3. Failed battery. 	<ol style="list-style-type: none"> 1. Install (new) 15 Amp fuse. See <i>System Control Panel</i>. 2. Open fuel valve(s); check propane tank. 3. Replace battery.
Engine shuts down during operation.	<ol style="list-style-type: none"> 1. Fuel supply turned off or depleted. 2. Fault indicator blinking. 	<ol style="list-style-type: none"> 1. Check fuel valves, fill propane tank. 2. Count blinks and refer to <i>Fault Detection System</i>.
Loss of power on circuits.	<ol style="list-style-type: none"> 1. Generator circuit breaker is open. 2. Transfer switch problems. 	<ol style="list-style-type: none"> 1. Reset circuit breaker. 2. See the transfer switch manual.
Unit will not exercise weekly.	<ol style="list-style-type: none"> 1. System Switch not on AUTO 2. Exercise timer not set. 3. Failed battery. 4. 15 Amp fuse missing or blown. 	<ol style="list-style-type: none"> 1. Set System Switch to AUTO. 2. Set exercise timer. 3. Replace battery. 4. Install (new) 15 Amp fuse.
Excessive Vibration	<ol style="list-style-type: none"> 1. Loose mechanical fastener. 	<ol style="list-style-type: none"> 1. Check and repair or contact local service facility.
Odor of fuel	<ol style="list-style-type: none"> 1. Fuel leak. 	<ol style="list-style-type: none"> 1. Turn off manual shutoff fuel valve. Contact local service facility.
Utility power returns, unit does not stop	<ol style="list-style-type: none"> 1. Blown fuses in transfer switch. 2. 5 minute minimum runtime not lapsed. 3. Poor wire connection or defective controllers 	<ol style="list-style-type: none"> 1. Install (new) fuses. 2. Wait 5 minutes. 3. Check and repair or contact local service facility.

California, U.S. EPA, and Briggs & Stratton Corporation Emissions Control Warranty Statement

Your Warranty Rights And Obligations

The California Air Resources Board, U.S. EPA, and Briggs & Stratton (B&S) are pleased to explain the emissions control system warranty on your Model Year 2011-2012 engine/equipment. In California, new small off-road engines and large spark ignited engines less than or equal to 1.0 liter must be designed, built, and equipped to meet the State's stringent anti-smog standards. B&S must warrant the emissions control system on your engine/equipment for the periods of time listed below provided there has been no abuse, neglect, or improper maintenance of your engine or equipment.

Your emissions control system may include parts such as the carburetor or fuel injection system, fuel tank, ignition system, and catalytic converter. Also included may be hoses, belts, connectors, sensors, and other emissions-related assemblies. Where a warrantable condition exists, B&S will repair your engine/equipment at no cost to you including diagnosis, parts, and labor.

Manufacturer's Warranty Coverage:

Small off-road engines and large spark ignited engines less than or equal to 1.0 liter are warranted for four years. If any emissions-related part on your engine/equipment is defective, the part will be repaired or replaced by B&S.

Owner's Warranty Responsibilities:

- As the engine/equipment owner, you are responsible for the performance of the required maintenance listed in your owner's manual. B&S recommends that you retain all receipts covering maintenance on your engine/equipment, but B&S cannot deny warranty solely for the lack of receipts or your failure to ensure the performance of all scheduled maintenance.
- As the engine/equipment owner, you should however be aware that B&S may deny you warranty coverage if your engine/equipment or a part has failed due to abuse, neglect, improper maintenance, or unapproved modifications.
- You are responsible for presenting your engine/equipment to a B&S distribution center, servicing dealer, or other equivalent entity, as applicable, as soon as a problem exists. The warranty repairs should be completed in a reasonable amount of time, not to exceed 30 days. If you have any questions regarding your warranty rights and responsibilities, you should contact Briggs and Stratton at 414 259-5262.

Briggs & Stratton Emissions Control Warranty Provisions

The following are specific provisions relative to your Emissions Control Warranty Coverage. It is in addition to the B&S engine warranty for non-regulated engines found in the Operator's Manual.

1. Warranted Emissions Parts

Coverage under this warranty extends only to the parts listed below (the emissions control systems parts) to the extent these parts were present on the engine purchased.

- a. Fuel Metering System
 - Cold start enrichment system (soft choke)
 - Carburetor and internal parts
 - Fuel pump
 - Fuel line, fuel line fittings, clamps
 - Fuel tank, cap and tether
 - Carbon canister
- b. Air Induction System
 - Air cleaner
 - Intake manifold
 - Purge and vent line
- c. Ignition System
 - Spark plug(s)
 - Magneto ignition system
- d. Catalyst System
 - Catalytic converter
 - Exhaust manifold
 - Air injection system or pulse valve
- e. Miscellaneous Items Used in Above Systems
 - Vacuum, temperature, position, time sensitive valves and switches
 - Connectors and assemblies

2. Length of Coverage

For a period of four years from date of original purchase, B&S warrants to the original purchaser and each subsequent purchaser that the engine is designed, built, and equipped so as to conform with all applicable regulations adopted by the Air Resources Board; that it is free from defects in material and workmanship that could cause the failure of a warranted part; and that it is identical in all material respects to the engine described in the manufacturer's application for certification. The warranty period begins on the date the engine is originally purchased.

The warranty on emissions-related parts is as follows:

- Any warranted part that is not scheduled for replacement as required maintenance in the owner's manual supplied, is warranted for the warranty period stated above. If any such part fails during the period of warranty coverage, the part will be repaired or replaced by B&S at no charge to the owner. Any such part repaired or replaced under the warranty will be warranted for the remaining warranty period.
- Any warranted part that is scheduled only for regular inspection in the owner's manual supplied, is warranted for the warranty period stated above. Any such part repaired or replaced under warranty will be warranted for the remaining warranty period.
- Any warranted part that is scheduled for replacement as required maintenance in the owner's manual supplied, is warranted for the period of time prior to the first scheduled replacement point for that part. If the part fails prior to the first scheduled replacement, the part will be repaired or replaced by B&S at no charge to the owner. Any such part repaired or replaced under warranty will be warranted for the remainder of the period prior to the first scheduled replacement point for the part.
- Add on or modified parts that are not exempted by the Air Resources Board may not be used. The use of any non exempted add on or modified parts by the owner will be grounds for disallowing a warranty claim. The manufacturer will not be liable to warrant failures of warranted parts caused by the use of a non exempted add on or modified part.

3. Consequential Coverage

Coverage shall extend to the failure of any engine components caused by the failure of any warranted emissions parts.

4. Claims and Coverage Exclusions

Warranty claims shall be filed according to the provisions of the B&S engine warranty policy. Warranty coverage does not apply to failures of emissions parts that are not original equipment B&S parts or to parts that fail due to abuse, neglect, or improper maintenance as set forth in the B&S engine warranty policy. B&S is not liable for warranty coverage of failures of emissions parts caused by the use of add-on or modified parts.

Look For Relevant Emissions Durability Period and Air Index Information On Your Small Off-Road Engine Emissions Label

Engines that are certified to meet the California Air Resources Board (CARB) small off-road Emissions Standard must display information regarding the Emissions Durability Period and the Air Index. Briggs & Stratton makes this information available to the consumer on our emissions labels. The engine emissions label will indicate certification information.

The Emissions Durability Period describes the number of hours of actual running time for which the engine is certified to be emissions compliant, assuming proper maintenance in accordance with the Operating & Maintenance Instructions. The following categories are used:

Moderate:

Engine is certified to be emissions compliant for 125 hours of actual engine running time.

Intermediate:

Engine is certified to be emissions compliant for 250 hours of actual engine running time.

Extended:

Engine is certified to be emissions compliant for 500 hours of actual engine running time.

For example, a typical walk-behind lawn mower is used 20 to 25 hours per year. Therefore, the Emissions Durability Period of an engine with an intermediate rating would equate to 10 to 12 years. Briggs & Stratton engines are certified to meet the United States Environmental Protection Agency (USEPA) Phase 2 emissions standards. For Phase 2 certified engines, the Emissions Compliance Period referred to on the Emissions Compliance label indicates the number of operating hours for which the engine has been shown to meet Federal emissions requirements.

For engines less than 225 cc displacement.

Category C = 125 hours

Category B = 250 hours

Category A = 500 hours

For engines of 225 cc or more displacement.

Category C = 250 hours

Category B = 500 hours

Category A = 1000 hours

Warranty

Limited Warranty

Briggs & Stratton Power Products Group, LLC will repair or replace, free of charge, any part(s) of the equipment that is defective in material or workmanship or both. Travel expenses are reimbursed as specified under the Briggs & Stratton Warranty Guidelines document to authorized Briggs & Stratton dealers for performing applicable warranty repair work. This warranty is effective for the time periods and subject to the conditions stated below. For all warranty service, find the nearest Authorized Service Dealer in our dealer locator map at BRIGGSandSTRATTON.COM.

THERE IS NO OTHER EXPRESS WARRANTY. IMPLIED WARRANTIES, INCLUDING THOSE OF MERCHANTABILITY AND FITNESS FOR A PARTICULAR PURPOSE, ARE LIMITED TO ONE YEAR FROM PURCHASE, OR TO THE EXTENT PERMITTED BY LAW. ANY AND ALL IMPLIED WARRANTIES ARE EXCLUDED. LIABILITY FOR INCIDENTAL OR CONSEQUENTIAL DAMAGES IS EXCLUDED TO THE EXTENT EXCLUSION IS PERMITTED BY LAW. Some states or countries do not allow limitations on how long an implied warranty lasts, and some states or countries do not allow the exclusion or limitation of incidental or consequential damages, so the above limitation and exclusion may not apply to you. This warranty gives you specific legal rights and you may also have other rights which vary from state to state or country to country.

Warranty Period

Consumer Use ¹	4 years or 1,600 hours, whichever comes first
Commercial Use ²	None
Rental Use ³	None
Prime Power ⁴	None

The warranty period begins on the date of purchase by the first retail consumer or commercial end user, and continues for the period of time stated in the table above.

- ¹ "Consumer" means personal residential household use by a retail consumer.
- ² "Commercial" means all other uses, including use for commercial, income producing or rental purposes. Once equipment has experienced commercial use, it shall thereafter be considered as commercial use for purposes of this warranty.
- ³ "Rental use" means any use of this product in a temporary or semi-permanently installed rental application. Once equipment has experienced rental use, it shall thereafter be considered rental use for purposes of this warranty.

- ⁴ For purposes of this warranty, "Prime Power" is defined where the generator is a source of power where no electrical power is available from the UTILITY POWER GRID. If no UTILITY power is available, the generator is considered the prime power source.

NO WARRANTY REGISTRATION IS NECESSARY TO OBTAIN WARRANTY ON BRIGGS & STRATTON PRODUCTS. SAVE YOUR PROOF OF PURCHASE RECEIPT. IF YOU DO NOT PROVIDE PROOF OF THE INITIAL PURCHASE DATE AT THE TIME WARRANTY SERVICE IS REQUESTED, THE MANUFACTURING DATE OF THE PRODUCT WILL BE USED TO DETERMINE THE WARRANTY PERIOD.

Warranty Terms continue on next page

About Your Warranty

We welcome warranty repair and apologize to you for being inconvenienced. Any Authorized Service Dealer may perform warranty repairs. Most warranty repairs are handled routinely, but sometimes requests for warranty service may not be appropriate. For example, warranty service would not apply if equipment damage occurred because of misuse, lack of routine maintenance, shipping, handling, warehousing or improper installation. Similarly, the warranty is void if the manufacturing date or the serial number on the equipment has been removed or the equipment has been altered or modified. During the warranty period, the Authorized Service Dealer, at its option, will repair or replace any part that, upon examination, is found to be defective under normal use and service. This warranty will not cover the following repairs and equipment:

- **Normal Wear:** Outdoor Power Equipment and engines, like all mechanical devices, needs periodic parts and service to perform well. This warranty does not cover repair when normal use has exhausted the life of a part or the equipment.
- **Installation and Maintenance:** This warranty does not apply to equipment or parts that have been subjected to improper or unauthorized installation or alteration and modification, misuse, negligence, accident, overloading, overspeeding, improper maintenance, repair or storage so as, in our judgment, to adversely affect its performance and reliability. This warranty also does not cover normal maintenance such as adjustments, fuel system cleaning and obstruction (due to chemical, dirt, carbon, lime, and so forth).

- **Other Exclusions:** This warranty excludes starting battery, accessory parts, wear items such as oil gauges, o-rings, filters, fuses, or spark plugs, etc., or damage or malfunctions resulting from accidents, abuse, modifications, alterations, or improper servicing or freezing or chemical deterioration. This warranty excludes failures due to acts of God and other force majeure events beyond the manufacturers control. And this warranty excludes used, reconditioned, and demonstration equipment; equipment used for prime power in place of utility power, equipment used in mobile or rental applications, and equipment used in life support applications.

Enclosure is warranted against surface rust and corrosion for the first year of the warranty period.

Surface rust and corrosion is defined as any rust or corrosion that has penetrated the paint but has not penetrated through the metal substructure.

Enclosure is warranted against rust-through for the first three years of the warranty period.

Rust-through is defined as rust or corrosion that has penetrated completely through the paint and metal substructure.

Enclosure is not warranted for surface rust or corrosion or complete rust-through that may result due to improper installation, damage to painted surfaces that compromise the paint's corrosion prevention properties, or if the unit is installed in environments that expose the generator to high levels of corrosive agents.

Warranty terms effective October 1, 2010 - replaces all undated Warranties and Warranties dated before October 1, 2010. 313771E, Rev. -, 10 September 2010

Generator Specifications

10 kW

Rated Maximum Load Current* (at 25°C/77°F, LP)*:

at 240 Volts	41.70 Amps
Rated AC Voltage	240 Volts
Phase	Single phase
Rated Frequency	60 Hertz
Normal Operating Range ...	-20°F (-28.8°C) to 104°F (40°C)
Output Sound Level	74.5 dB(A) at 23 ft. (7 m) at full load
Shipping Weight	595 lb (270 kg)

12 kW

Rated Maximum Load Current* (at 25°C/77°F, LP)*:

at 240 Volts	50.00 Amps
Rated AC Voltage	240 Volts
Phase	Single phase
Rated Frequency	60 Hertz
Normal Operating Range ...	-20°F (-28.8°C) to 104°F (40°C)
Output Sound Level	74.5 dB(A) at 23 ft. (7 m) at full load
Shipping Weight	605 lb (274 kg)

Engine Specifications

Displacement	49.42 ci. (810 cc)
Spark Plug Gap	0.020 in. (0.51 mm)
Spark Plug Torque	180 lb-in. (20 Nm)
Armature Air Gap	0.008 - 0.012 in. (0.20 - 0.30 mm)
Intake Valve Clearance	0.004 - 0.006 in. (0.10 - 0.15 mm)
Exhaust Valve Clearance .	0.009 - 0.011 in. (0.23 - 0.28 mm)
Oil Capacity	64 oz. (1.9 L)
Engine Oil.....	SAE 5W-30 (Synthetic)

Displacement	49.42 ci. (810 cc)
Spark Plug Gap	0.020 in. (0.51 mm)
Spark Plug Torque	180 lb-in. (20 Nm)
Armature Air Gap	0.008 - 0.012 in. (0.20 - 0.30 mm)
Intake Valve Clearance	0.004 - 0.006 in. (0.10 - 0.15 mm)
Exhaust Valve Clearance .	0.009 - 0.011 in. (0.23 - 0.28 mm)
Oil Capacity	64 oz. (1.9 L)
Engine Oil.....	SAE 5W-30 (Synthetic)

Common Service Parts

Air Filter, Oval	798748
Oil - Synthetic	100074
Oil Filter	492932
Resistor Spark Plug	692051
Long Life Platinum Spark Plug	5066

Air Filter, Oval	798748
Oil - Synthetic	100074
Oil Filter	492932
Resistor Spark Plug	692051
Long Life Platinum Spark Plug	5066

*This generator is rated in accordance with UL (Underwriters Laboratories) 2200 (stationary engine generator assemblies) and CSA (Canadian Standards Association) standard C22.2 No. 100-04 (motors and generators).

Power Rating

The gross power rating for individual gas engine models is labeled in accordance with SAE (Society of Automotive Engineers) code J1940 (Small Engine Power & Torque Rating Procedure), and rating performance has been obtained and corrected in accordance with SAE J1995 (Revision 2002-05). Torque values are derived at 3060 RPM; horsepower values are derived at 3600 RPM. Net power values are taken with exhaust and air cleaner installed whereas gross power values are collected without these attachments. Actual gross engine power will be higher than net engine power and is affected by, among other things, ambient operating conditions and engine-to-engine variability. Given the wide array of products on which engines are placed, the gas engine may not develop the rated gross power when used in a given piece of power equipment. This difference is due to a variety of factors including, but not limited to, the variety of engine components (air cleaner, exhaust, charging, cooling, carburetor, fuel pump, etc.), application limitations, ambient operating conditions (temperature, humidity, altitude), and engine-to-engine variability. Due to manufacturing and capacity limitations, Briggs & Stratton may substitute an engine of higher rated power for this Series engine.

Intentionally Left Blank

Not
for
Reproduction