

## Introduction

### Purpose

This manual provides instructions to install the following Security Bracket (Air Gap Grill Replacement) Security Kits on The Advantage® Series units:

- M07744K007 (48" Wide Frame)
- M07744K008 (36" Narrow Frame)

*Note: One kit is required per dispenser.*

The Security Bracket (Air Gap Grill Replacement) protects the air gap and prevents people from opening the Upper Bezel Door or removing the Lower Access Door.

*Notes: 1) If Americans With Disabilities Act (ADA) keypads are used, they must be located on the left side of the dispenser. ADA keypads mounting on the right side will not allow the Security Bracket to mount.*

*2) To open the bezel door or the lower door, the Security Bracket must be removed.*

### Table of Contents

Topic	Page
<a href="#">Introduction</a>	1
<a href="#">Important Safety Information</a>	3
<a href="#">Installing the Security Bracket Security Kit</a>	5

### Abbreviations and Acronyms

Term	Description
ADA	Americans With Disabilities Act
ATC	Automatic Temperature Compensation

### Required Tools

The following tools are required to install the Security Bracket Security Kit:

- Hex Socket Driver Set
- Allen® Wrench Set

## Parts List

Item	Description	Part Number	Quantity	
			M07744K007	M07744K008
1	Assembly Security Bracket	M08360A004	2	-
		M09140A001	-	2
2	Bracket, Security Lock	M09124B001	2	-
		M09134B001	-	2
3	Screw 5/16-18 X 3/4 TH FM	K85736-43	4	4
4	Screw TPT Hex Washer HD 10	K85736-02	8	8
5	Screw Cap SHD 1/4-20X2 BL	Q11098-10	8	6
6	Washer Flat .265X.500X.032	Q11439-07	8	6
7	Retainer 1/4-20 THD	Q10922-02	8	6
8	Security Bracket Security Kit Installation Instructions	MDE-4640	1	1

*Note:1) The locks are not provided with the kit. They must be purchased separately.*

*2) The kit was designed using Master Lock #40 padlock. However, other locks can be used.*

## Related Documents

Document Number	Title	GOLD Library
MDE-2530	Pump and Dispenser Installation Manual	The Advantage and Legacy® models
MDE-2540	The Advantage, Legacy® & MPD Series Owners Manual	The Advantage and Legacy models
MDE-2996	Automatic Temperature Compensation (ATC) Kit (K94159-XX) for The Advantage Series	The Advantage and Legacy models
PT-1728	The Advantage Illustrated Parts Manual	Parts Manual

# Important Safety Information

This section introduces the hazards and safety precautions associated with installing, inspecting, maintaining or servicing this product. Before performing any task on this product, read this safety information and the applicable sections in this manual, where additional hazards and safety precautions for your task will be found. Fire, explosion, electrical shock or pressure release could occur and cause death or serious injury, if these safe service procedures are not followed.

## Preliminary Precautions

You are working in a potentially dangerous environment of flammable fuels, vapors, and high voltage or pressures. Only trained or authorized individuals knowledgeable in the related procedures should install, inspect, maintain or service this equipment.

## Emergency Total Electrical Shut-Off

The first and most important information you must know is how to stop all fuel flow to the pump/dispenser and island. Locate the switch or circuit breakers that shut off all power to all fueling equipment, dispensing devices, and Submerged Turbine Pumps (STPs).

**⚠ WARNING**

 The EMERGENCY STOP, ALL STOP, and PUMP STOP buttons at the cashier's station WILL NOT shut off electrical power to the pump/dispenser. This means that even if you activate these stops, fuel may continue to flow uncontrolled.

 You must use the TOTAL ELECTRICAL SHUT-OFF in the case of an emergency and not the console's ALL STOP and PUMP STOP or similar keys.

## Total Electrical Shut-Off Before Access

Any procedure that requires access to electrical components or the electronics of the dispenser requires total electrical shut off of that unit. Understand the function and location of this switch or circuit breaker before inspecting, installing, maintaining, or servicing Gilbarco equipment.

## Evacuating, Barricading and Shutting Off

Any procedure that requires access to the pump/dispenser or STPs requires the following actions:



- An evacuation of all unauthorized persons and vehicles from the work area
- Use of safety tape, cones or barricades at the affected unit (s)
- A total electrical shut-off of the affected unit (s)

## Read the Manual

Read, understand and follow this manual and any other labels or related materials supplied with this equipment. If you do not understand a procedure, call a Gilbarco Authorized Service Contractor or call the Gilbarco Support Center at 1-800-800-7498. It is imperative to your safety and the safety of others to understand the procedures before beginning work.

## Follow the Regulations

Applicable information is available in National Fire Protection Association (NFPA) 30A; *Code for Motor Fuel Dispensing Facilities and Repair Garages*, NFPA 70; *National Electrical Code (NEC)*, Occupational Safety and Hazard Association (OSHA) regulations and federal, state, and local codes. All these regulations must be followed. Failure to install, inspect, maintain or service this equipment in accordance with these codes, regulations and standards may lead to legal citations with penalties or affect the safe use and operation of the equipment.

## Replacement Parts

Use only genuine Gilbarco replacement parts and retrofit kits on your pump/dispenser. Using parts other than genuine Gilbarco replacement parts could create a safety hazard and violate local regulations.

## Safety Symbols and Warning Words

This section provides important information about warning symbols and boxes.

### Alert Symbol



This safety alert symbol is used in this manual and on warning labels to alert you to a precaution which must be followed to prevent potential personal safety hazards. Obey safety directives that follow this symbol to avoid possible injury or death.

### Signal Words

These signal words used in this manual and on warning labels tell you the seriousness of particular safety hazards. The precautions below must be followed to prevent death, injury or damage to the equipment:



**DANGER:** Alerts you to a hazard or unsafe practice which will result in death or serious injury.



**WARNING:** Alerts you to a hazard or unsafe practice that could result in death or serious injury.



**CAUTION with Alert symbol:** Designates a hazard or unsafe practice which may result in minor injury.

**CAUTION without Alert symbol:** Designates a hazard or unsafe practice which may result in property or equipment damage.

## Working With Fuels and Electrical Energy

### Prevent Explosions and Fires

Fuels and their vapors will explode or burn, if ignited. Spilled or leaking fuels cause vapors. Even filling customer tanks will cause potentially dangerous vapors in the vicinity of the dispenser or island.

## Important Safety Information

### No Open Fire



Open flames from matches, lighters, welding torches or other sources can ignite fuels and their vapors.



### No Sparks - No Smoking

Sparks from starting vehicles, starting or using power tools, burning cigarettes, cigars or pipes can also ignite fuels and their vapors. Static electricity, including an electrostatic charge on your body, can cause a spark sufficient to ignite fuel vapors. Every time you get out of a vehicle, touch the metal of your vehicle, to discharge any electrostatic charge before you approach the dispenser island.

### Working Alone

It is highly recommended that someone who is capable of rendering first aid be present during servicing. Familiarize yourself with Cardiopulmonary Resuscitation (CPR) methods, if you work with or around high voltages. This information is available from the American Red Cross. Always advise the station personnel about where you will be working, and caution them not to activate power while you are working on the equipment. Use the OSHA Lockout/ Tagout procedures. If you are not familiar with this requirement, refer to this information in the service manual and OSHA documentation.

### Working With Electricity Safely

Ensure that you use safe and established practices in working with electrical devices. Poorly wired devices may cause a fire, explosion or electrical shock. Ensure that grounding connections are properly made. Take care that sealing devices and compounds are in place. Ensure that you do not pinch wires when replacing covers. Follow OSHA Lockout/Tagout requirements. Station employees and service contractors need to understand and comply with this program completely to ensure safety while the equipment is down.

### Hazardous Materials

Some materials present inside electronic enclosures may present a health hazard if not handled correctly. Ensure that you clean hands after handling equipment. Do not place any equipment in the mouth.

#### WARNING

The pump/dispenser contains a chemical known to the State of California to cause cancer.

#### WARNING

The pump/dispenser contains a chemical known to the State of California to cause birth defects or other reproductive harm.

## In an Emergency

### Inform Emergency Personnel

Compile the following information and inform emergency personnel:

- Location of accident (for example, address, front/back of building, and so on)
- Nature of accident (for example, possible heart attack, run over by car, burns, and so on)
- Age of victim (for example, baby, teenager, middle-age, elderly)
- Whether or not victim has received first aid (for example, stopped bleeding by pressure, and so on)
- Whether or not a victim has vomited (for example, if swallowed or inhaled something, and so on)

#### WARNING



Gasoline ingested may cause unconsciousness and burns to internal organs.

Do not induce vomiting.

Keep airway open.

Oxygen may be needed at scene.

Seek medical advice immediately.

#### WARNING



Gasoline inhaled may cause unconsciousness and burns to lips, mouth and lungs.

Keep airway open.

Seek medical advice immediately.

#### WARNING



Gasoline spilled in eyes may cause burns to eye tissue.

Irrigate eyes with water for approximately 15 minutes.

Seek medical advice immediately.

#### WARNING



Gasoline spilled on skin may cause burns.

Wash area thoroughly with clear water.

Seek medical advice immediately.

**IMPORTANT:** Oxygen may be needed at scene if gasoline has been ingested or inhaled. Seek medical advice immediately.

### Lockout/Tagout

Lockout/Tagout covers servicing and maintenance of machines and equipment in which the unexpected energization or start-up of the machine(s) or equipment or release of stored energy could cause injury to employees or personnel. Lockout/Tagout applies to all mechanical, hydraulic, chemical or other energy, but does not cover electrical hazards. Subpart S of 29 CFR Part 1910 - Electrical Hazards, 29 CFR Part 1910.333 contains specific Lockout/ Tagout provision for electrical hazards.

# Installing the Security Bracket Security Kit

To install the Security Bracket Security Kit, proceed as follows:

- 1 Open the main Bezel by removing the two bolts at the bottom of the Bezel and the latches, as shown in [Figure 1](#).

Figure 1: Removing the Bolts

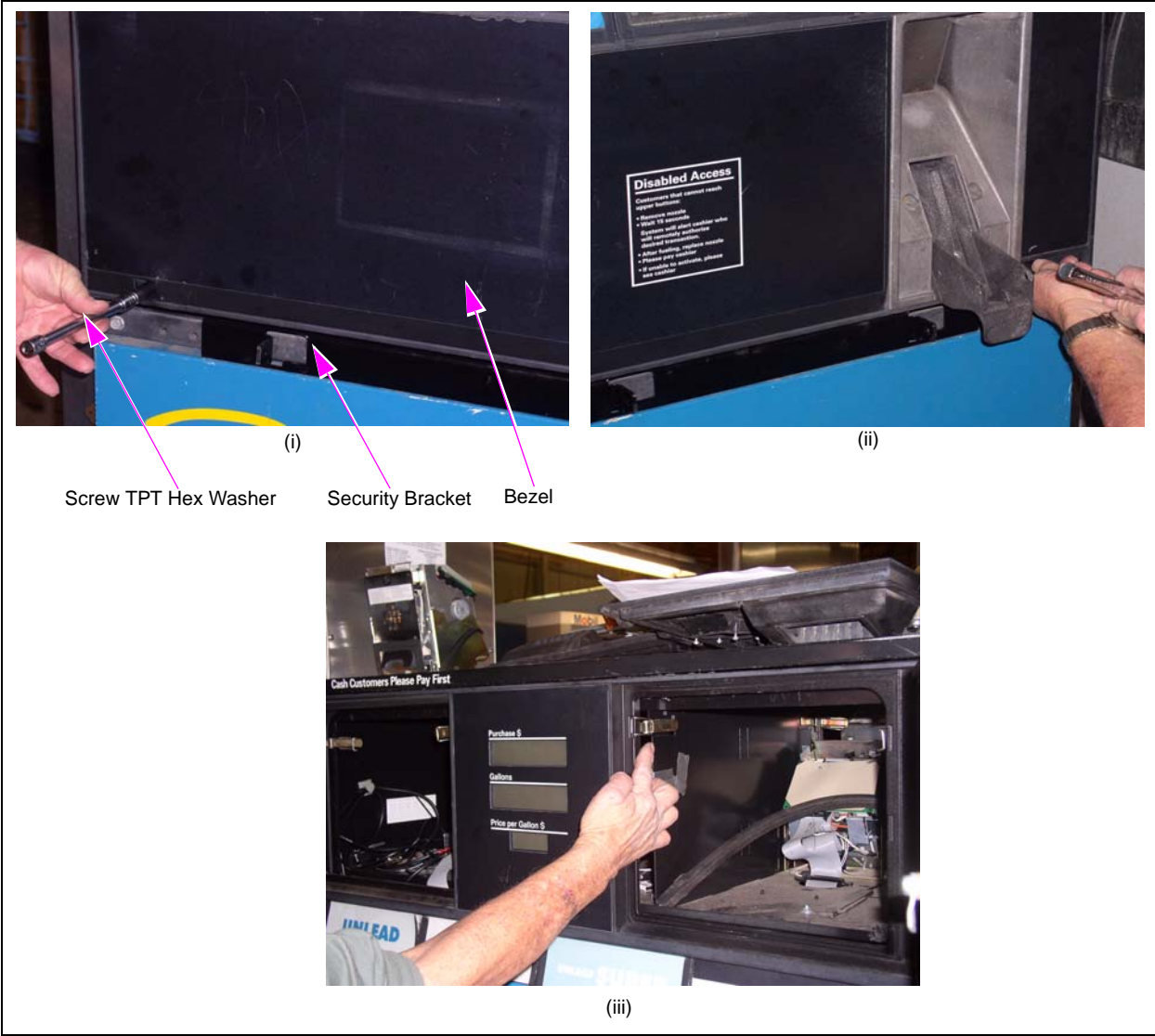

- 2 Remove the existing Air Gap Grill by removing the four 8-32 X 3/8 screws on each end of the grill. Discard the screws.

**Figure 2: Air Gap Grill with Screws**

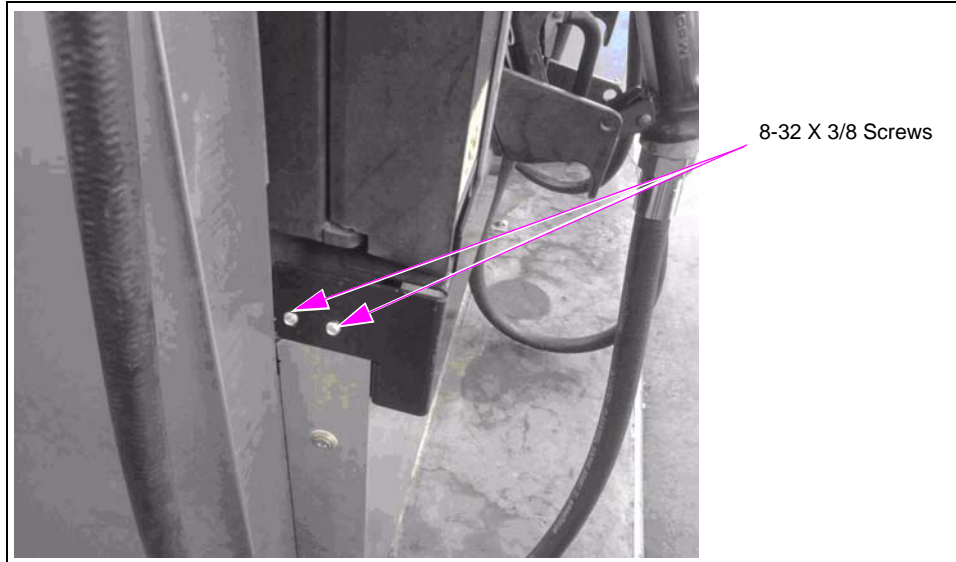

- 3 Remove and discard the old 5/16 - 18 bolts.
  - For Narrow Frame units, remove the three 5/16 - 18 bolts that hold the lower Air Gap Plate to the frame rail.

**Figure 3: Narrow Frame Unit with the Grill Removed**

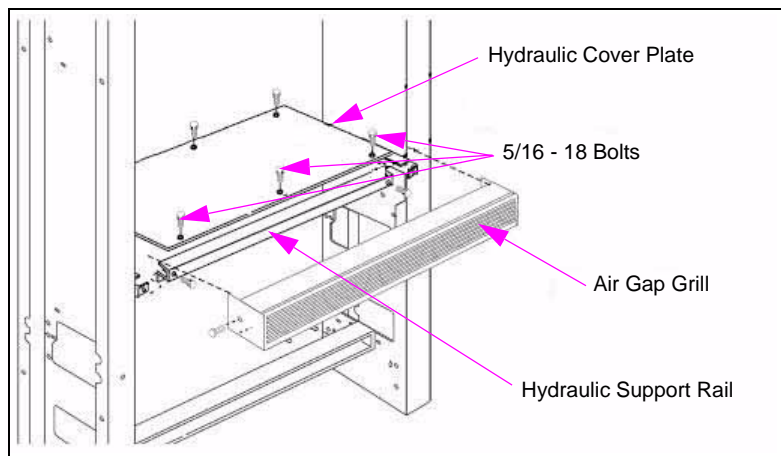

- For Wide Frame units, remove the four 5/16 - 18 bolts that hold the lower Air Gap Plate to the frame rail (see [Figure 4](#)).

**Figure 4: Wide Frame Unit with the Grill Removed**

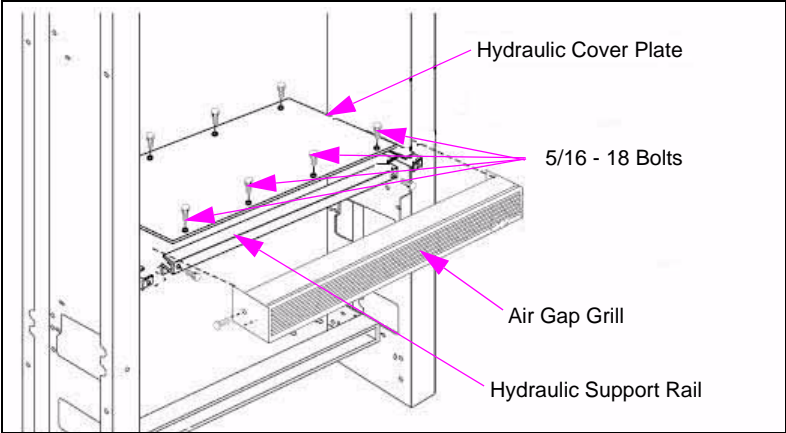

- 4 Use the replacement 5/16 - 16 X 3/4 (K85736-43) screw supplied, to install the Security Lock Bracket, as shown in [Figure 5](#).

**Figure 5: Installing the Security Lock Bracket**

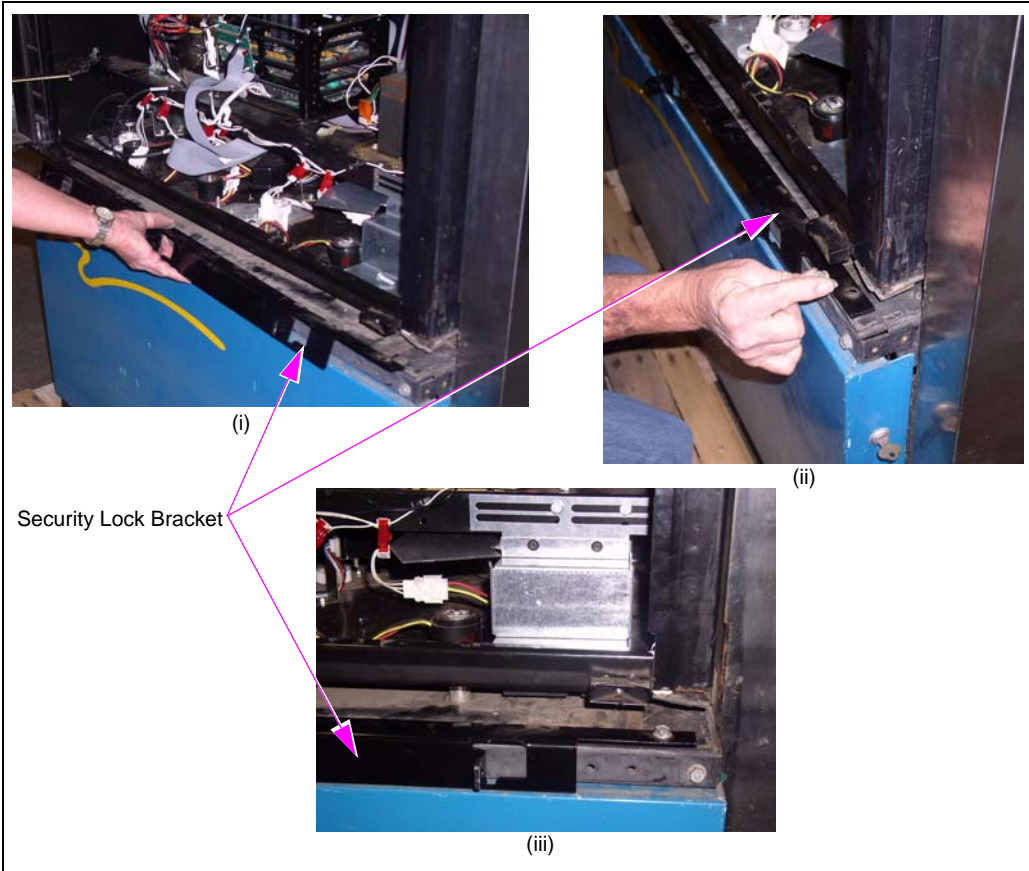

- 5 Replace any missing retaining bolts with items 5, 6, and 7 provided in the kit (refer to “Parts List” on page 2).
- 6 Close the bezel and install the security bracket in place of the Air Gap Grill (see Figure 6). Use the K85736-02 screws provided in the kit (see item 4 in “Parts List” on page 2), to hold the bracket in place.  
*Note: The notch at the rear of the security bracket (Air Gap Grill replacement) engages the Security Lock Bracket.*
- 7 Install pancake locks [see (v) of Figure 6].  
*Notes: 1) The lock bracket extends through the security bracket (Air Gap Grill replacement).  
2) The kit was designed using Master Lock #40 padlock. However, others locks can be used.*

**Figure 6: Installing the Security Bracket and Pancake Locks**

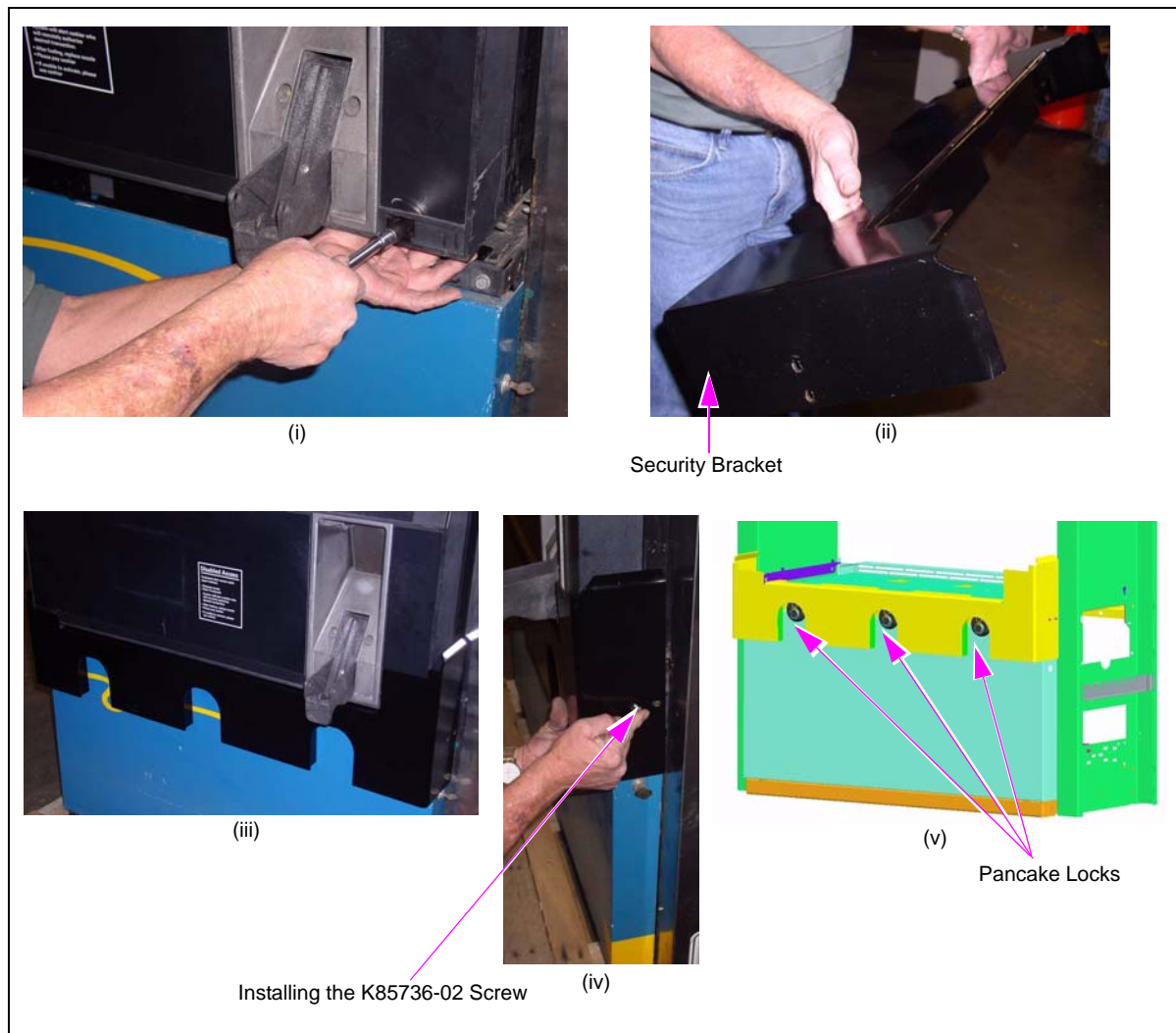

*Note: The locks are for reference only. They are not included in the kit.*

Figure 7 shows the completed installation on Wide Frame units.

**Figure 7: After Installation (Wide Frame)**



*Note: The Security Bracket Assembly on Narrow Frame units has two locking positions. The Security Bracket Assembly on Wide Frame units has three locking positions.*

- 8** Repeat steps 1 to 7 for the other side of the unit.

The installation of the Security Lock Bracket Security Kit is complete.

---

*Allen® is a registered trademark of Industrial Fasteners, Inc. Legacy® and The Advantage® Series are registered trademarks of Gilbarco Inc.*



© 2009 Gilbarco Inc.  
7300 West Friendly Avenue · Post Office Box 22087  
Greensboro, North Carolina 27420  
Phone (336) 547-5000 · <http://www.gilbarco.com> · Printed in the U.S.A.  
MDE-4640B Security Bracket Security Kit Installation Instructions for The Advantage® Series · January 2009