



Fall Protection

flexiguard[®]

Fall Arrest System

Model Numbers: 8517760, 8517761,
8517762, 8517763

USER INSTRUCTION MANUAL

1

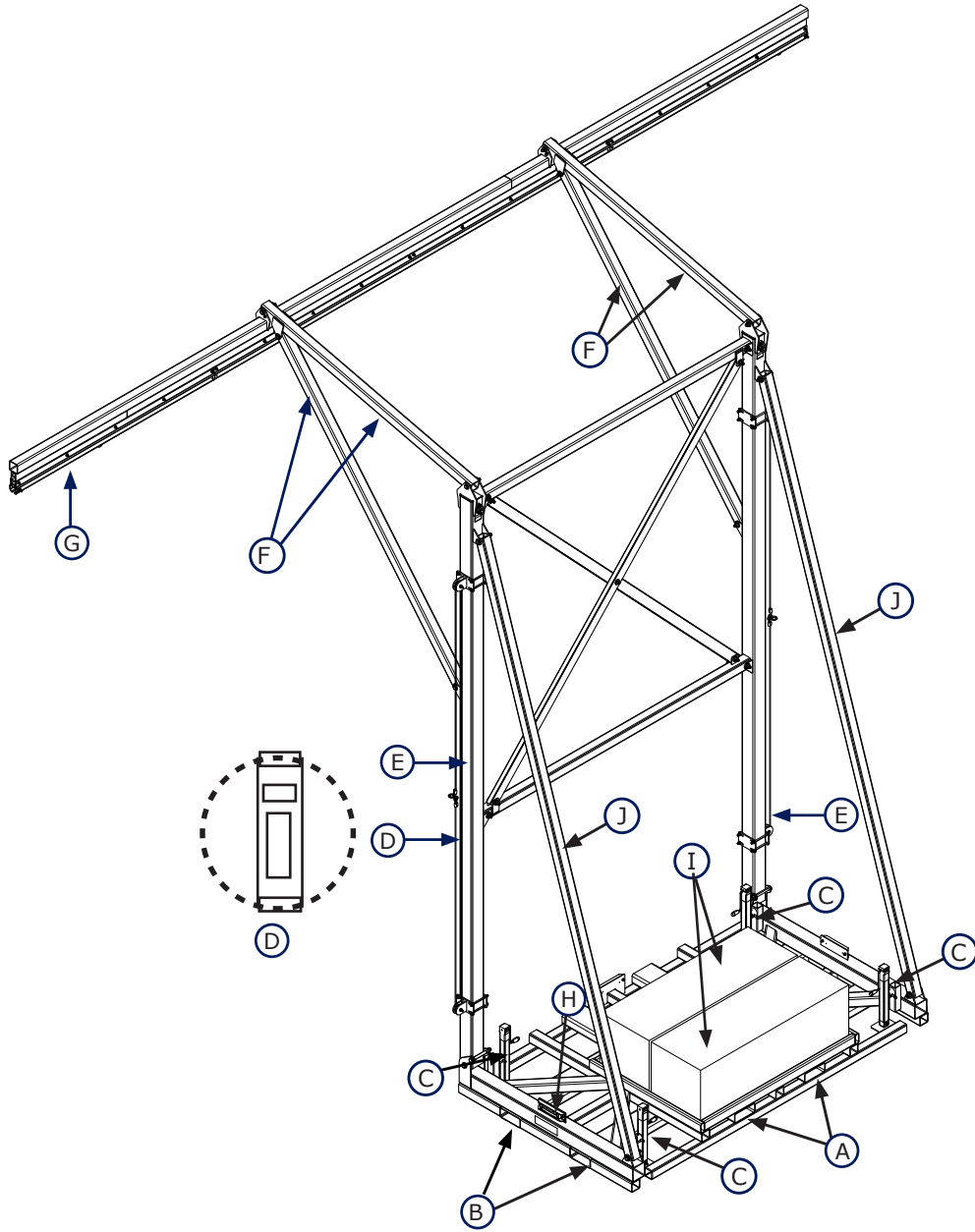

2

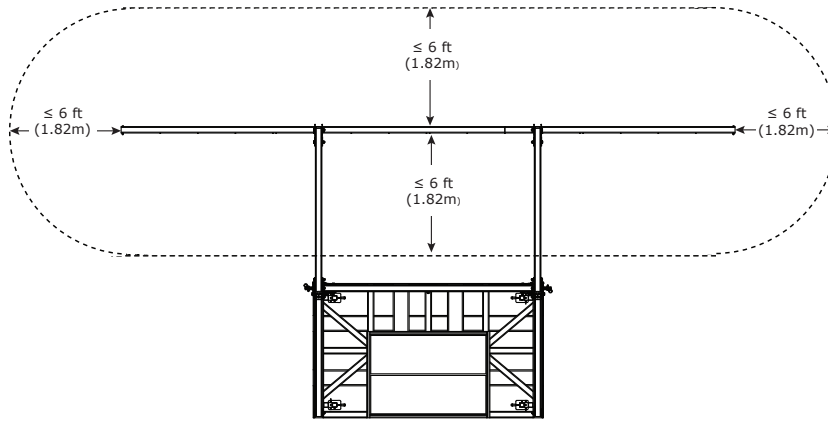

3

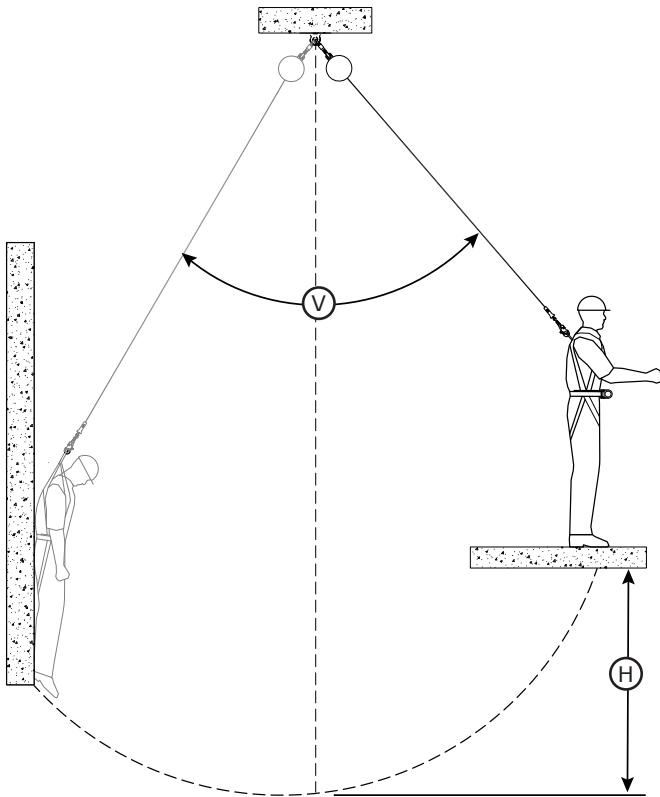

| F ft (m) | ← H - ft (m) → | | | | | | |
|-------------|----------------|---------------|---------------|---------------|---------------|---------------|---------------|
| | 0 (0.0) | 1 (0.3) | 2 (0.6) | 3 (0.9) | 4 (1.2) | 5 (1.5) | 6 (1.8) |
| 0 (0.0) | 0.0 (0.0) | 1.0 (0.3) | 2.0 (0.6) | 3.0 (0.9) | 4.0 (1.2) | 5.0 (1.5) | 6.0 (1.8) |
| 1 (0.3) | 1.0 (0.3) | 1.4 (0.4) | 2.2 (0.7) | 3.2 (1.0) | 4.1 (1.3) | 5.1 (1.6) | 6.1 (1.9) |
| 2 (0.6) | 2.0 (0.6) | 2.2 (0.7) | 2.8 (0.9) | 3.6 (1.1) | 4.5 (1.4) | 5.4 (1.6) | 6.3 (1.9) |
| 3 (0.9) | 3.0 (0.9) | 3.2 (1.0) | 3.6 (1.1) | 4.2 (1.3) | 5.0 (1.5) | 5.8 (1.8) | 6.7 (2.0) |
| 4 (1.2) | 4.0 (1.2) | 4.1 (1.3) | 4.5 (1.4) | 5.0 (1.5) | 5.7 (1.7) | 6.4 (2.0) | 7.2 (2.2) |
| 5 (1.5) | 5.0 (1.5) | 5.1 (1.6) | 5.4 (1.6) | 5.8 (1.8) | 6.4 (2.0) | 7.1 (2.2) | 7.8 (2.4) |
| 6 (1.8) | 6.0 (1.8) | 6.1 (1.9) | 6.3 (1.9) | 6.7 (2.0) | 7.2 (2.2) | 7.8 (2.4) | 8.5 (2.6) |
| 7 (2.1) | 7.0 (2.1) | 7.1 (2.2) | 7.3 (2.2) | 7.6 (2.3) | 8.1 (2.5) | 8.6 (2.6) | 9.2 (2.8) |
| 8 (2.4) | 8.0 (2.4) | 8.1 (2.5) | 8.2 (2.5) | 8.5 (2.6) | 8.9 (2.7) | 9.4 (2.9) | 10.0 (3.0) |
| 9 (2.7) | 9.0 (2.7) | 9.1 (2.8) | 9.2 (2.8) | 9.5 (2.9) | 9.8 (3.0) | 10.3 (3.1) | 10.8 (3.3) |
| 10 (3.0) | 10.0 (3.0) | 10.0 (3.1) | 10.2 (3.1) | 10.4 (3.2) | 10.8 (3.3) | 11.2 (3.4) | 11.7 (3.6) |
| 11 (3.4) | 11.0 (3.4) | 11.0 (3.4) | 11.2 (3.4) | 11.4 (3.5) | 11.7 (3.6) | 12.1 (3.7) | 12.5 (3.8) |
| 12 (3.7) | 12.0 (3.7) | 12.0 (3.7) | 12.2 (3.7) | 12.4 (3.8) | 12.6 (3.9) | 13.0 (4.0) | 13.4 (4.1) |
| 13 (4.0) | 13.0 (4.0) | 13.0 (4.0) | 13.2 (4.0) | 13.3 (4.1) | 13.6 (4.1) | 13.9 (4.2) | 14.3 (4.4) |
| 14 (4.3) | 14.0 (4.3) | 14.0 (4.3) | 14.1 (4.3) | 14.3 (4.4) | 14.6 (4.4) | 14.9 (4.5) | 15.2 (4.6) |
| 15 (4.6) | 15.0 (4.6) | 15.0 (4.6) | 15.1 (4.6) | 15.3 (4.7) | 15.5 (4.7) | 15.8 (4.8) | 16.2 (4.9) |
| 16 (4.9) | 16.0 (4.9) | 16.0 (4.9) | 16.1 (4.9) | 16.3 (5.0) | 16.5 (5.0) | 16.8 (5.1) | 17.1 (5.2) |
| 17 (5.2) | 17.0 (5.2) | 17.0 (5.2) | 17.1 (5.2) | 17.3 (5.3) | 17.5 (5.3) | 17.7 (5.4) | 18.0 (5.5) |
| 18 (5.5) | 18.0 (5.5) | 18.0 (5.5) | 18.1 (5.5) | 18.2 (5.6) | 18.4 (5.6) | 18.7 (5.7) | 19.0 (5.8) |
| 19 (5.8) | 19.0 (5.8) | 19.0 (5.8) | 19.1 (5.8) | 19.2 (5.9) | 19.4 (5.9) | 19.6 (6.0) | 19.9 (6.1) |
| 20 (6.1) | 20.0 (6.1) | 20.0 (6.1) | 20.1 (6.1) | 20.2 (6.2) | 20.4 (6.2) | 20.6 (6.3) | 20.9 (6.4) |
| 21 (6.4) | 21.0 (6.4) | 21.0 (6.4) | 21.1 (6.4) | 21.2 (6.5) | 21.4 (6.5) | 21.6 (6.6) | 21.8 (6.7) |
| 22 (6.7) | 22.0 (6.7) | 22.0 (6.7) | 22.1 (6.7) | 22.2 (6.8) | 22.4 (6.8) | 22.6 (6.9) | 22.8 (7.0) |
| 23 (7.0) | 23.0 (7.0) | 23.0 (7.0) | 23.1 (7.0) | 23.2 (7.1) | 23.3 (7.1) | 23.5 (7.2) | 23.8 (7.2) |
| 24 (7.3) | 24.0 (7.3) | 24.0 (7.3) | 24.1 (7.3) | 24.2 (7.4) | 24.3 (7.4) | 24.5 (7.5) | 24.7 (7.5) |
| 25 (7.6) | 25.0 (7.6) | 25.0 (7.6) | 25.1 (7.6) | 25.2 (7.7) | 25.3 (7.7) | 25.5 (7.8) | 25.7 (7.8) |

4

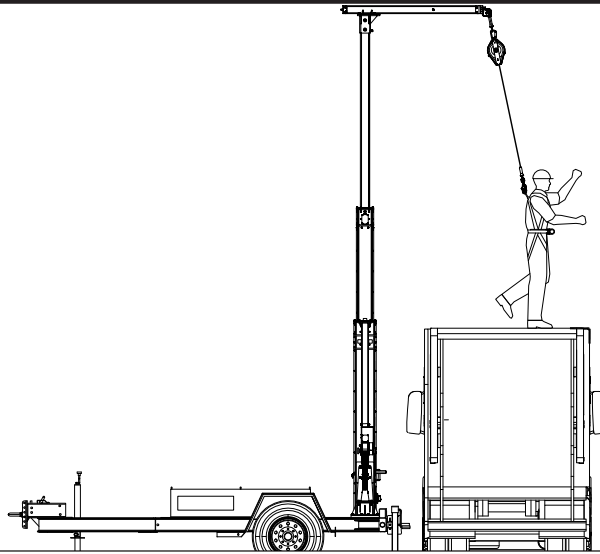

5

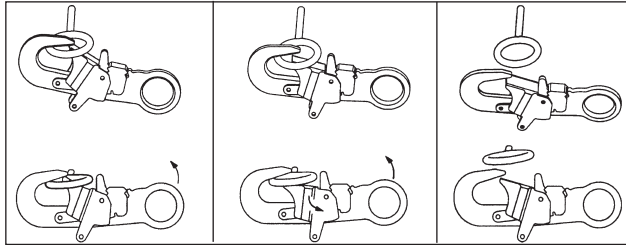

A

B

C

6

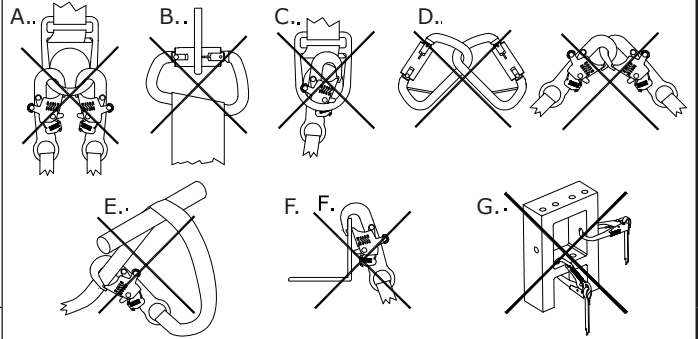

7

| | W | L |
|-----------|------------------|-------------------|
| 8522028 * | 2.77" (70.36 mm) | 6.50" (165.10 mm) |

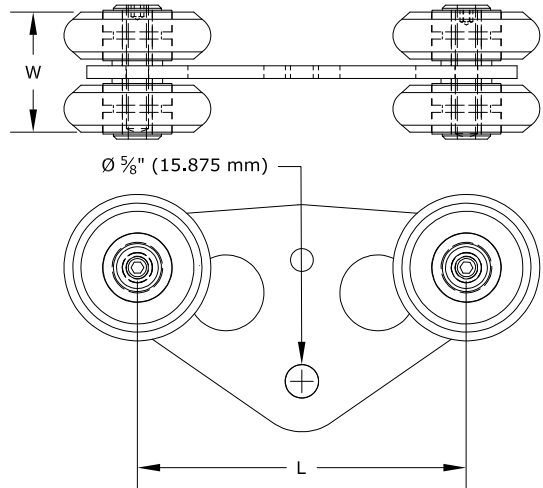
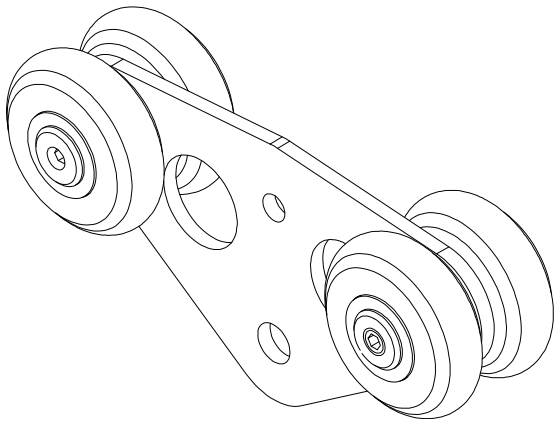

SAFETY INFORMATION

Please read, understand, and follow all safety information contained in these instructions prior to the use of this Flexiguard System. **FAILURE TO DO SO COULD RESULT IN SERIOUS INJURY OR DEATH.**

These instructions must be provided to the user of this equipment. Retain these instructions for future reference.

Intended Use:

This Flexiguard System is intended for use as part of a complete fall protection or rescue system.

Use in any other application including, but not limited to, material handling, recreational or sports related activities, or other activities not described in the User Instructions, is not approved by 3M and could result in serious injury or death.

This system is only to be used by trained users in workplace applications.

WARNING

This Flexiguard System is part of a personal fall protection or rescue system. It is expected that all users be fully trained in the safe installation and operation of the complete system. **Misuse of this system could result in serious injury or death.** For proper selection, operation, installation, maintenance, and service, refer to all Product Instructions and all manufacturer recommendations, see your supervisor, or contact 3M Technical Service.

- **To reduce the risks associated with transporting a Flexiguard system which, if not avoided, could result in serious injury or death:**
 - Ensure the system is properly secured or configured prior to transport. Refer to the User Instructions for detailed transportation requirements.
 - Only transport below 5 mph (8 km/h) and at inclines of 10° or less, or as outlined in the User Instructions.
 - Ensure the system will not contact overhead objects or electrical hazards while transporting or in use.
- **To reduce the risks associated with working with a Flexiguard system which, if not avoided, could result in serious injury or death:**
 - Inspect all components of the system before each use, at least annually, and after any fall event, in accordance with the User Instructions.
 - If inspection reveals an unsafe or defective condition, remove the system from service and repair or replace according to the User Instructions.
 - Any system that has been subject to fall arrest or impact force must be immediately removed from service. Refer to the User Instructions or contact 3M Fall Protection.
 - The substrate or structure on which the system is attached/positioned must be able to sustain the static loads specified for the system in the orientations permitted in the User Instructions or Installation Instructions.
 - Do not exceed the number of allowable users as per the User Instructions.
 - Never attach to a system until it is fully assembled, positioned, adjusted, and installed. Do not adjust the system while a user is attached.
 - Never work outside the safe work area as defined by the User Instructions.
 - Do not connect to the system while it is being transported or installed.
 - Always maintain 100% tie-off when transferring between anchor points on the system.
 - Use caution when installing, using, and moving the system as moving parts may create potential pinch points.
 - Ensure proper lockout/tagout procedures have been followed when applicable.
 - Only connect fall protection subsystems to the designated anchorage connection point on the system.
 - When drilling holes for assembly or installation of the system, ensure no electric lines, gas lines, or other critical materials or equipment will be contacted by the drill.
 - Ensure that fall protection systems/subsystems assembled from components made by different manufacturers are compatible and meet the requirements of applicable standards, including the ANSI Z359 or other applicable fall protection codes, standards, or requirements. Always consult a Competent or Qualified Person before using these systems.
- **To reduce the risks associated with working at heights which, if not avoided, could result in serious injury or death:**
 - Ensure your health and physical condition allow you to safely withstand all of the forces associated with working at height. Consult with your doctor if you have any questions regarding your ability to use this equipment.
 - Never exceed allowable capacity of your fall protection equipment.
 - Never exceed maximum free fall distance of your fall protection equipment.
 - Do not use any fall protection equipment that fails pre-use or other scheduled inspections, or if you have concerns about the use or suitability of the equipment for your application. Contact 3M Technical Services with any questions.
 - Some subsystem and component combinations may interfere with the operation of this equipment. Only use compatible connections. Consult 3M prior to using this equipment in combination with components or subsystems other than those described in the User Instructions.
 - Use extra precautions when working around moving machinery (e.g. top drive of oil rigs) electrical hazards, extreme temperatures, chemical hazards, explosive or toxic gases, sharp edges, or below overhead materials that could fall onto you or the fall protection equipment.
 - Use Arc Flash or Hot Works devices when working in high heat environments.
 - Avoid surfaces and objects that can damage the user or equipment.
 - Ensure there is adequate fall clearance when working at height.
 - Never modify or alter your fall protection equipment. Only 3M or parties authorized in by 3M may make repairs to the equipment.
 - Prior to use of fall protection equipment, ensure a rescue plan is in place which allows for prompt rescue if a fall incident occurs.
 - If a fall incident occurs, immediately seek medical attention for the fallen worker for the worker who has fallen.
 - Do not use a body belt for fall arrest applications. Use only a Full Body Harness.
 - Minimize swing falls by working as directly below the anchorage point as possible.
 - If training with this device, a secondary fall protection system must be utilized in a manner that does not expose the trainee to an unintended fall hazard.
 - Always wear appropriate personal protective equipment when installing, using, or inspecting the device/system.

Prior to installation and use of this equipment, record the product identification information from the ID label in the Inspection and Maintenance Log at the back of this manual.

PRODUCT DESCRIPTION:

The Counterweight Rail Fall Arrest System combines easy access to elevated work areas with fall protection from the ground for the duration of the work performed. The system includes a Horizontal Rail Assembly with Trolleys that ride in Track Rails to any position along the Rail Assembly. The Trolleys serve as attachment points for the anchorage of a Personal Fall Arrest System (PFAS). The system can be moved by use of a lift truck or maintenance vehicle when equipped with proper accessories.

Figure 1 illustrates components of the Counterweight Rail Fall Arrest System. See Table 1 for Component Specifications. Table 1 stipulates the required amount of counterweight for use.

Table 1 – Specifications

| System Specifications: | | | |
|----------------------------------|---|---|---|
| Capacity: | 2 person up to 310 lbs (141 kg) each | | |
| Anchorage: | Structure supporting the Counterweight Trailer Fall Arrest System must withstand a 15,500 lb (68.9 kN) vertical load. | | |
| Offset: | 8 ft (2.43 m) | | |
| Total System Weight: | Approximately 11,850 lb. (5,375 kg) with Concrete. Approximately 5,050 lbs (2,291 kg) with concrete removed. | | |
| Counterweight Required | Min. 6,800 lbs (3084.4 kg) Recommended two 4000 psi (27.6 Mpa) concrete blocks, 2'x2'x6' (60cm x 60cm x 182cm) | | |
| Component Specifications: | | | |
| Figure 1 Reference | Component | Materials | Note: |
| (A) | Primary Forklift Pockets | Steel Tube | |
| (B) | Alternate Forklift Pockets | Steel Tube | |
| (C) | Leveling Jack | Body & Hardware - Steel Cable - 1/16" SS | |
| (D) | Safety Labels | Vinyl | |
| (E) | Vertical Support Beams | Steel | |
| (F) | Rail Supports | Aluminum | |
| (G) | Glide Rail | Aluminum | Maximum Capacity: 2 person up to 310 lbs each (141 kg) including clothes, tools, etc. per Boom Arm and Anchorage Connection Point |
| (H) | Slope Indicator | Plastic | |
| (I) | Counterweight | Concrete | 2X Weights with Concrete: 3,400 lb (1,542 kg) each |
| (J) | Tie Back Supports | Aluminum | |

1 Anchorage Connection Points: Each Anchorage Connection Point has been tested and verified to a safety factor of 2:1 per OSHA.

1.0 PRODUCT APPLICATION

- 1.1 PURPOSE:** Flexiguard™ Anchorage Systems are designed to provide anchorage connection points for a Personal Fall Arrest System (PFAS).
- 1.2 SUPERVISION:** Installation of this equipment must be supervised by a Qualified Person¹. Use of this equipment must be supervised by a Qualified Person¹.
- 1.3 TRAINING:** This equipment must be installed and used by persons trained in its correct application. This manual is to be used as part of an employee training program as required by OSHA. It is the responsibility of the users and installers of this equipment to ensure they are familiar with these instructions, trained in the correct care and use of this equipment, and are aware of the operating characteristics, application limitations, and consequences of improper use of this equipment.
- 1.4 RESCUE PLAN:** When using this equipment and connecting subsystem(s), the employer must have a rescue plan and the means at hand to implement and communicate that plan to users, authorized persons², and rescuers³. A trained, on-site rescue team is recommended. Team members should be provided with the equipment and techniques to perform a successful rescue. Training should be provided on a periodic basis to ensure rescuer proficiency.
- 1.5 INSPECTION FREQUENCY:** The Flexiguard Anchorage System shall be inspected by the user before each use and, additionally, by a competent person other than the user at intervals of no longer than one year.⁴ Inspection procedures are described in the "Inspection and Maintenance Log". Results of each Competent Person inspection should be recorded on copies of the "Inspection and Maintenance Log".
- 1.6 AFTER A FALL:** If the Flexiguard Anchorage System is subjected to the forces of arresting a fall, it must be removed from the field of service immediately and replaced or inspected by an Authorized 3M Representative.

2.0 SYSTEM CONSIDERATIONS

- 2.1 ANCHORAGE:** Structure on which the Flexiguard Anchorage System is placed or mounted must meet the Anchorage specifications defined in Table 1.
- 2.2 PERSONAL FALL ARREST SYSTEM:** Figure 1 illustrates the application of this Flexiguard Anchorage System. Personal Fall Arrest Systems (PFAS) used with the system must meet applicable OSHA, ANSI, state, and federal requirements. The PFAS shall incorporate a Full Body Harness and Self-Retracting Device (SRD) with a 900 lb (4 kN) Maximum Arresting Force.
- 2.3 FALL PATH AND SRL LOCKING SPEED:** A clear path is required to assure positive locking of an SRL. Situations which do not allow for an unobstructed fall path should be avoided. Working in confined or cramped spaces may not allow the body to reach sufficient speed to cause the SRL to lock if a fall occurs. Working on slowly shifting material, such as sand or grain, may not allow enough speed buildup to cause the SRL to lock.
- 2.4 HAZARDS:** Use of this equipment in areas with environmental hazards may require additional precautions to prevent injury to the user or damage to the equipment. Hazards may include, but are not limited to: heat, chemicals, corrosive environments, high voltage power lines, explosive or toxic gases, moving machinery, sharp edges, or overhead materials that may fall and contact the user or Personal Fall Arrest System.
- 2.5 FALL CLEARANCE:** There must be sufficient clearance below the user to arrest a fall before the user strikes the ground or other obstruction. Fall Clearance is dependent on the following factors:
- Deceleration Distance
 - Worker Height
 - Elevation of Anchorage Connector
 - Free Fall Distance
 - Movement of Harness Attachment Element
 - Connecting Subsystem Length
- See the Personal Fall Arrest System manufacturer's instructions for specifics regarding Fall Clearance calculation.
- 2.6 SWING FALLS:** Swing Falls occur when the anchorage point is not directly above the point where a fall occurs (see). The force of striking an object in a swing fall may cause serious injury or death. Minimize swing falls by working as directly below the anchorage point as possible. Do not permit a swing fall if injury could occur. Swing falls will significantly increase the clearance required when a Self-Retracting Device or other variable length connecting subsystem is used.
- 2.7 SHARP EDGES:** Avoid working where Lifeline or Lanyard components of the Personal Fall Arrest System (PFAS) can contact or abrade against unprotected sharp edges (see Figure 4). Where contact with a sharp edge is unavoidable, cover the edge with protective material (A).
- 2.8 COMPONENT COMPATIBILITY:** 3M equipment is designed for use with 3M approved components and subsystems only. Substitutions or replacements made with non-approved components or subsystems may jeopardize compatibility of equipment and may effect the safety and reliability of the complete system.

1 Qualified Person: A person with a recognized degree of professional certificate and with extensive knowledge, training, and experience in the fall protection and rescue field who is capable of designing, analyzing, evaluating, and specifying fall protections and rescue systems to the extent required by OSHA and other applicable standards.

2 Authorized Person: For purposes of the Z359 standards, a person assigned by the employer to perform duties at a location where the person will be exposed to a fall hazard.

3 Rescuer: Person or persons other than the rescue subject acting to perform an assisted rescue by operation of a rescue system.

4 Inspection Frequency: Extreme working conditions (harsh environments, prolonged use, etc.) may require increasing the frequency of competent person inspections.

2.9 CONNECTOR COMPATIBILITY: Connectors are considered to be compatible with connecting elements when they have been designed to work together in such a way that their sizes and shapes do not cause their gate mechanisms to inadvertently open regardless of how they become oriented. Contact 3M if you have any questions about compatibility. Connectors (hooks, carabiners, and D-rings) must be capable of supporting at least 5,000 lbs. (22.2 kN). Connectors must be compatible with the anchorage or other system components. Do not use equipment that is not compatible. Non-compatible connectors may unintentionally disengage (see Figure 5). Connectors must be compatible in size, shape, and strength. If the connecting element to which a snap hook or carabiner attaches is undersized or irregular in shape, a situation could occur where the connecting element applies a force to the gate of the snap hook or carabiner (A). This force may cause the gate to open (B), allowing the snap hook or carabiner to disengage from the connecting point (C).

Self-locking snap hooks and carabiners are required by ANSI Z359 and OSHA.

2.10 MAKING CONNECTIONS: Snap hooks and carabiners used with this equipment must be self-locking. Ensure all connections are compatible in size, shape and strength. Do not use equipment that is not compatible. Ensure all connectors are fully closed and locked.

3M connectors (snap hooks and carabiners) are designed to be used only as specified in each product's user's instructions. See Figure 6 for examples of inappropriate connections. Do not connect snap hooks and carabiners:

- A. To a D-ring to which another connector is attached.
- A. In a manner that would result in a load on the gate. Large throat snap hooks should not be connected to standard size D-rings or similar objects which will result in a load on the gate if the hook or D-ring twists or rotates, unless the snap hook complies is equipped with a 3,600 lb (16 kN) gate. Check the marking on your snap hook to verify that it is appropriate for your application.
- B. In a false engagement, where features that protrude from the snap hook or carabiner catch on the anchor, and without visual confirmation seems to be fully engaged to the anchor point.
- C. To each other.
- D. Directly to webbing or rope lanyard or tie-back (unless the manufacturer's instructions for both the lanyard and connector specifically allows such a connection).
- E. To any object which is shaped or dimensioned such that the snap hook or carabiner will not close and lock, or that roll-out could occur.
- F. In a manner that does not allow the connector to align properly while under load.

3.0 INSTALLATION

Installation of the Flexiguard™ Counterweight Rail Fall Arrest System (FAS) must be supervised by a Qualified Person. The installation must be certified by a Qualified Person as meeting the criteria for a Certified Anchorage, or that it is capable of supporting the potential forces that could be encountered during a fall.

This system is designed to be used on level ground only. If you have any questions regarding the safe terrain for system installation and operation, please contact 3M.

3.1 PLANNING: Plan your fall protection system prior to installation of the Counterweight Rail Fall Arrest System (FAS). Account for all factors that may affect your safety before, during and after a fall. Consider all requirements, limitations and specifications as defined in Sections 1 and 2.

3.2 ASSEMBLY: See IFU 5903234 for system assembly steps.

3.3 FOUR-WHEELED, SMALL-EYED SRD TROLLEYS: Glide Rail Trolley options vary and are based on the applicable trolley frame system requirements.

Connection point for SRDs attached with an approved Double-Locking Carabiner. Small eye minimizes loss of overhead clearance, keeping the worker's attachment point as high as possible relative to their dorsal D-Ring. Model Number and dimensions are specified in Figure 7.

After the Trolleys have been fully installed, reinspect all components for damage, correct orientation, and proper torque on all nuts and bolts. Attach the intended fall arrest equipment (SRDs, Lanyards, etc.) to each Trolley and walk the Trolley the entire length of the Track Assembly to ensure the Trolley Wheels travel smoothly in the Track.

4.0 USE

This system is designed to be used on level ground only. If you have any questions regarding if your terrain is safe for system use, please contact 3M. Do not attempt to adjust the height of the rail system by setting items under the leveling feet to gain more height. The Fixed-Height rail system must only be used when all four (4) leveling feet are safely touching the ground.

4.1 BEFORE EACH USE: Verify that your work area and Personal Fall Arrest System (PFAS) meet all criteria defined in Section 2 and a formal Rescue Plan is in place. Inspect the Counterweight Rail Fall Arrest System FAS per the 'User' inspection points defined on the 'Inspection and Maintenance Log' (Table 2). If inspection reveals an unsafe or defective condition, do not use the system. Remove the system from service and contact 3M regarding replacement or repair.

SAFE WORK AREA: Figure 2 illustrates the Safe Work Area for the Fall Arrest System. Try to work directly below the Anchorage Connection Point to minimize Swing Fall. The angle of the Self-Retracting Lifeline should never be more than 30° from vertical and the Horizontal Distance between the anchorage connection point and the worker should not be greater than 6 ft (1.82 m).

4.2 USING THE COUNTERWEIGHT HORIZONTAL RAIL SYSTEM:

- Step 1.** Position the Counterweight Horizontal Rail System over the desired work area/object. Place the unit into position so the Rail Assembly is centered in the work area to maximize the effective safe work area (See Figure 2), and reduce the potential for a fall. The Leveling Feet must be positioned over a stable, level surface capable of supporting the weight of the rail system.
- Step 2.** Secure and level the Counterweight Horizontal Rail System: Use the level supplied with the system to determine if the system is resting level on the work surface. If uneven terrain is present, use the integrated jack assemblies to level the system. Do not use the rail system if the system is not level within 1 degree in any direction.
- Step 3. Don a Full Body Harness:** Don a Full Body Harness per the manufacturer's instructions.
- Step 4. Connect the SRD Lifeline to the Full Body Harness:** Connect the Self Locking Snap Hook or Self Locking/Self Closing Carabiner on the end of the SRD Lifeline to the Front or Back D-Ring on the Full Body Harness. To ensure a safe connection, always follow the instructions provided in the SRD and Full Body Harness manufacturers' instructions and observe the requirements in Section 2 of this manual regarding *Compatibility of Connectors and Connections*.
- Step 5. When attached to the SRD:** The worker is free to move about within recommended working areas at normal speeds. The Trolley should roll freely in the Rail Assembly. The Lifeline should extend smoothly and retract without hesitation. If slack line condition is created in normal use, the unit should be inspected and serviced by an authorized service center. Should a fall occur, the SRD will lock and arrest the fall. Upon rescue, remove the SRD from use. Inspect as described in manufacturer's instructions. When working with the SRD, allow the lifeline to recoil back into the device under control. Allowing the lifeline to be fully extended for long periods of time may cause premature weakening of the retraction spring.

The maximum number of people that may be attached to the Counterweight Horizontal Frame System is stated by the system labelling; each using an individual Trolley and SRD. No more than one (1) person should be attached to a single Trolley at any time.

The SRD line must not drag or bend over a leading edge while accessing the work area. To eliminate that problem reposition the unit. Follow the SRD manufacturer's instructions carefully.

5.0 TRAINING

It is the responsibility of the user to assure they are familiar with these instructions, and are trained in the correct care and use of this equipment. Users must also be aware of the operating characteristics, application limits, and the consequences of improper use of this equipment.

6.0 INSPECTION

- 6.1 INSPECTION FREQUENCY:** The Flexiguard Fall Arrest System must be inspected at the intervals defined in Section 1. Inspection procedures are described in the "Inspection and Maintenance Log". Inspect all other components of the Fall Protection System per the frequencies and procedures defined in the manufacturer's instructions.

Some Flexiguard Fall Arrest Systems are equipped with a Radio Frequency Identification (RFID) Tag. The RFID Tag can be used in conjunction with a Handheld Reading Device to simplify inspection and inventory control and provide records for your fall protection equipment.

- 6.2 DEFECTS:** If inspection reveals an unsafe or defective condition, remove the Fall Arrest System from service immediately and contact 3M regarding replacement or repair. Do not attempt to repair the Fall Arrest System.

Only 3M or parties authorized in writing by 3M may make repairs to this equipment.

- 6.3 PRODUCT LIFE:** The functional life of the Fall Arrest System is determined by work conditions and maintenance. As long as the product passes inspection criteria, it may remain in service.

7.0 MAINTENANCE, SERVICING, STORAGE

- 7.1 CLEANING:** Periodically clean the Fall Arrest System's metal components with a soft brush, warm water, and a mild soap solution. Ensure parts are thoroughly rinsed with clean water.

Although highly resistant to chemicals and environmental conditions, avoid contaminating the Flexiguard Fall Arrest System with acids, bitumen, cement, paint, cleaning fluids, etc. If the equipment contacts acids or other caustic chemicals, remove from service and wash with water and a mild soap solution. Inspect per Table 2 before returning to service.

- 7.2 SERVICE:** Only 3M or parties authorized in writing by 3M may make repairs to this equipment. If the Flexiguard Fall Arrest System has been subject to fall force or inspection reveals an unsafe or defective conditions, remove the system from service and contact 3M regarding replacement or repair.

- 7.3 STORAGE AND TRANSPORT:** When not in use, store and transport the Fall Arrest System and associated fall protection equipment in a cool, dry, clean environment out of direct sunlight. Avoid areas where chemical vapors may exist. Thoroughly inspect components after extended storage.

8.0 LABELS

Labels must be replaced if they are not fully legible.



9511857



9505175



9504547



9502313

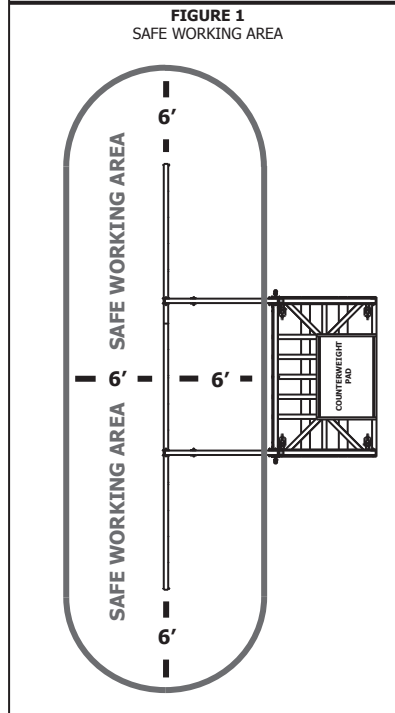
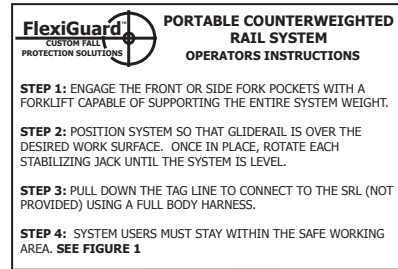

- THIS SYSTEM IS APPROVED FOR USE WITH RETRACTABLE DEVICES AND SHOCK ABSORBERS WITH A MAXIMUM ARRESTING FORCE (M.A.F.) RATING OF 900 lb (4kN) OR LESS.
- TRANSFERRING FROM ONE SRL TO ANOTHER **MUST BE DONE** SO YOU ARE ATTACHED TO AT LEAST ONE SRL AT ALL TIMES.
- NO MORE THAN ONE PERSON MAY BE ATTACHED TO A GLIDE RAIL TROLLEY AT ANY GIVEN TIME. SEE BELOW TO DETERMINE THE MAXIMUM NUMBER OF PERSONS ABLE TO USE THIS SYSTEM. NEVER EXCEED THE MAXIMUM USER RATING.
- ALL USERS MUST READ AND UNDERSTAND THE INSTRUCTIONS PRIOR TO USING THIS SYSTEM.
- BEWARE OF OVERHEAD POWER LINES OR OTHER HAZARDS WHICH MAY CAUSE ELECTRIC SHOCK.
- SYSTEM MUST BE WITHIN 1 DEGREE OF LEVEL PRIOR TO USE.
- THE CORRECT AMOUNT OF COUNTERWEIGHT MUST BE INSTALLED PRIOR TO

THIS MAN-RATED SYSTEM IS DESIGNED FOR A MAXIMUM OF

2 PERSONS

USER CAPACITY IN ACCORDANCE WITH MANUFACTURER'S INSTRUCTIONS. FAILURE TO COMPLY MAY RESULT IN SERIOUS INJURY OR DEATH.

9510749 REV B

9510749

Table 2 – Inspection and Maintenance Log

| Inspection Date: | | Inspected By: | | |
|-------------------------------|---|--------------------------|--------------------------|--|
| Components: | Inspection: (See Section 6 for <i>Inspection Frequency</i>) | User | Competent Person | |
| Flexiguard System | Inspect structural components for significant rust or corrosion that may affect the structural integrity of the fall protection system. Minor cosmetic surface rust or surface corrosion that has developed over time is acceptable on certain areas of the system. Any areas of concern should be reviewed by a Qualified Person ¹ (or contact 3M). | <input type="checkbox"/> | <input type="checkbox"/> | |
| Inspect Jacks & Counterweight | Inspect the Jacks for cracks, dents, bends, etc. Ensure the appropriate amount of counterweight is in place. (See Table 1.) | <input type="checkbox"/> | <input type="checkbox"/> | |
| Inspect hardware | Verify there are no loose nuts and bolts on the system and all pins are in place. Tighten all loose bolts to the proper torque specifications. | <input type="checkbox"/> | <input type="checkbox"/> | |
| Labels | Verify that all labels are securely attached and are legible. (See 'Labels'.) | <input type="checkbox"/> | <input type="checkbox"/> | |
| PFAS and Other Equipment | Additional Personal Fall Arrest System (PFAS) equipment (harness, SRD, etc) that are used with the Flexiguard Anchorage System should be installed and inspected per the manufacturer's instructions. | <input type="checkbox"/> | <input type="checkbox"/> | |

| | |
|--------------------------|---------------------------|
| Serial Number(s): | Date Purchased: |
| Model Number: | Date of First Use: |

| | |
|---------------------------------------|--------------|
| Corrective Action/Maintenance: | Approved By: |
| | Date: |
| Corrective Action/Maintenance: | Approved By: |
| | Date: |
| Corrective Action/Maintenance: | Approved By: |
| | Date: |
| Corrective Action/Maintenance: | Approved By: |
| | Date: |
| Corrective Action/Maintenance: | Approved By: |
| | Date: |
| Corrective Action/Maintenance: | Approved By: |
| | Date: |
| Corrective Action/Maintenance: | Approved By: |
| | Date: |

1 Qualified Person: A person with a recognized degree of professional certificate and with extensive knowledge, training, and experience in the fall protection and rescue field who is capable of designing, analyzing, evaluating, and specifying fall protections and rescue systems to the extent required by OSHA and other applicable standards.

U.S. PRODUCT WARRANTY, LIMITED REMEDY AND LIMITATION OF LIABILITY

WARRANTY: THE FOLLOWING IS MADE IN LIEU OF ALL WARRANTIES OR CONDITIONS, EXPRESS OR IMPLIED, INCLUDING THE IMPLIED WARRANTIES OR CONDITIONS OF MERCHANTABILITY OR FITNESS FOR A PARTICULAR PURPOSE.

Unless otherwise provided by applicable law, 3M fall protection products are warranted against factory defects in workmanship and materials for a period of one year from the date of installation or first use by the original owner.

LIMITED REMEDY: Upon written notice to 3M, 3M will repair or replace any product determined by 3M to have a factory defect in workmanship or materials. 3M reserves the right to require product be returned to its facility for evaluation of warranty claims. This warranty does not cover product damage due to wear, abuse, misuse, damage in transit, failure to maintain the product or other damage beyond 3M's control. 3M will be the sole judge of product condition and warranty options.

This warranty applies only to the original purchaser and is the only warranty applicable to 3M's fall protection products. Please contact 3M's customer service department at 800-328-6146 or via email at 3MFallProtection@mmm.com for assistance.

LIMITATION OF LIABILITY: TO THE EXTENT PERMITTED BY APPLICABLE LAW, 3M IS NOT LIABLE FOR ANY INDIRECT, INCIDENTAL, SPECIAL OR CONSEQUENTIAL DAMAGES INCLUDING, BUT NOT LIMITED TO LOSS OF PROFITS, IN ANY WAY RELATED TO THE PRODUCTS REGARDLESS OF THE LEGAL THEORY ASSERTED.



Fall Protection

USA

3833 SALA Way
Red Wing, MN 55066-5005
Toll Free: 800.328.6146
Phone: 651.388.8282
Fax: 651.388.5065
3Mfallprotection@mmm.com

Brazil

Rua Anne Frank, 2621
Boqueirão Curitiba PR
81650-020
Brazil
Phone: 0800-942-2300
falecoma3m@mmm.com

Mexico

Calle Norte 35, 895-E
Col. Industrial Vallejo
C.P. 02300 Azcapotzalco
Mexico D.F.
Phone: (55) 57194820
3msaludocupacional@mmm.com

Colombia

Compañía Latinoamericana de Seguridad S.A.S.
Carrera 106 #15-25 Interior 105 Manzana 15
Zona Franca - Bogotá, Colombia
Phone: 57 1 6014777
fallprotection-co@mmm.com

Canada

260 Export Boulevard
Mississauga, ON L5S 1Y9
Phone: 905.795.9333
Toll-Free: 800.387.7484
Fax: 888.387.7484
3Mfallprotection-ca@mmm.com

EMEA (Europe, Middle East, Africa)

EMEA Headquarters:
Le Broc Center
Z.I. 1re Avenue - BP15
06511 Carros Le Broc Cedex
France
Phone: + 33 04 97 10 00 10
Fax: + 33 04 93 08 79 70
informationfallprotection@mmm.com

Australia & New Zealand

95 Derby Street
Silverwater
Sydney NSW 2128
Australia
Phone: +(61) 2 8753 7600
Toll-Free : 1800 245 002 (AUS)
Toll-Free : 0800 212 505 (NZ)
Fax: +(61) 2 8753 7603
anzfallprotectionsales@mmm.com

Asia

Singapore:
1 Yishun Avenue 7
Singapore 768923
Phone: +65-6450 8888
Fax: +65-6552 2113
TotalFallProtection@mmm.com

Shanghai:

19/F, L'Avenue, No.99 Xian Xia Rd
Shanghai 200051, P R China
Phone: +86 21 62539050
Fax: +86 21 62539060
3MFallProtection-CN@mmm.com

Korea:

3M Korea Ltd
20F, 82, Uisadang-daero,
Yeongdeungpo-gu, Seoul
Phone: +82-80-033-4114
Fax: +82-2-3771-4271
TotalFallProtection@mmm.com

Japan:

3M Japan Ltd
6-7-29, Kitashinagawa, Shinagawa-ku, Tokyo
Phone: +81-570-011-321
Fax: +81-3-6409-5818
psd.jp@mmm.com

WEBSITE:
3M.com/FallProtection



EU DECLARATION OF CONFORMITY:
3M.com/FallProtection/DOC