

resideo



Braukmann

CBU140

Compact Booster Unit - single pump To ensure the quality of potable water according to EN1717

Instructions



32304091-001



Contents

1. Safety Guidelines	3	Start-up	11
1.1 Safety instructions in this manual	3	7.1 Safety instructions for start-up.....	11
1.2 General safety instructions.....	3	7.2 Start-up requirements.....	11
1.3 Further safety regulations.....	3	7.3 Fill up and vent the pump and tank.....	11
1.4 Unauthorised operation types.....	3	7.4 Switching the system on.....	11
1.5 Residual dangers in handling the compact booster unit.....	4	7.5 Function check.....	11
1.5.1 Mechanical residual dangers.....	4	7.5.1 Checking the protection against dry running.....	11
1.5.2 Residual dangers pertaining to fluids.....	4	7.6 Start-up checklist.....	11
1.5.3 Residual electrical hazards.....	4	8. Operation	11
1.5.4 Residual biological hazards.....	4	9. Maintenance	12
1.5.5 Residual chemical hazards.....	4	9.1 Safety instructions for maintenance.....	12
1.5.6 Consequences and dangers that result from not observing the manual.....	5	9.2 Overview of inspection tasks.....	12
1.6 Basic Safety Measures.....	5	9.3 Inspection.....	12
1.6.1 Keep information available.....	5	9.3.1 Check protection against dry running.....	12
1.6.2 For environmental protection.....	5	9.3.2 Check pressure hoses.....	12
1.6.3 Modifications to the compact booster unit.....	5	9.3.3 Check pump control.....	12
1.7 Duty of due care of the operator.....	5	9.3.4 Check floating ring seal leakage.....	12
1.8 Safety instructions for the operator/operating personnel.....	5	9.3.5 Check preload pressure of membrane pressure expansion vessel.....	12
1.9 Safety instructions for maintenance, inspections and assembly work.....	5	9.4 Maintenance.....	12
1.10 Requirements for operating personnel.....	5	10. Troubleshooting	13
1.10.1 Operating personnel.....	5	10.1 Measures for elimination of pressure surges.....	13
1.11 Personal safety equipment.....	5	10.1.1 Enlargement of the inlet line.....	13
2. General information	6	10.1.2 Setting pressure reducing valve.....	13
2.1 Conformity with the following norms.....	6	10.1.3 Throttle pressure surge.....	13
2.2 Warranty and liability.....	6	10.1.4 Membrane pressure expansion vessel.....	13
2.3 Storage and perfect condition.....	6	11. Shut-down, disassembly, restart	14
2.4 Illustrations.....	6	11.1 Shutting down the compact booster unit.....	14
2.5 Symbols.....	6	11.2 Restarting the compact booster unit.....	14
2.6 Other applicable documents.....	6	12. Storage	14
2.7 Glossary.....	6	12.1 Short-term storage.....	14
3. Description	7	12.2 Storage/Preservation.....	14
3.1 Pump Output.....	7	12.3 Storage conditions.....	14
3.2 Backfeed for 3/4" pipes.....	7	13. Disposal	14
3.3 Noise expectancy values.....	7	14. Spare Parts	14
3.4 Authorised environmental conditions.....	7	15. Start-up protocol	15
3.5 Type label.....	7	16. Declaration of no objection	16
3.6 Version.....	8	17. Proof of Maintenance	17
3.7 Overview.....	8		
3.7.1 Installation type.....	8		
3.8 Intended use.....	8		
3.9 Non-intended use.....	8		
3.10 Options.....	8		
4. Function	8		
4.1 Construction dimensions.....	8		
5. Shipping	9		
5.1 Check condition upon delivery.....	9		
5.2 Transportation.....	9		
6. Assembly	9		
6.1 General safety instructions.....	9		
6.2 Installation according to EN1717.....	9		
6.3 Inspection before assembly.....	10		
6.3.1 Installation site.....	10		
6.4 Installing the compact booster unit.....	10		
6.5 Installing the pipelines.....	10		
6.5.1 Water connection.....	10		
6.5.2 Pressure connection.....	10		
6.5.3 Connecting the overflow.....	10		
6.6 Electrical connection.....	10		
6.6.1 Safety instructions.....	10		
6.7 Verification of the waterflow.....	10		

7.

1. Safety Guidelines

1.1 Safety instructions in this manual

 Danger
Places with this sign signify that death, severe bodily injury or significant property damage will occur if the appropriate precautionary measures are not followed!
 Warning
Places with this sign signify that death, severe bodily injury or significant property damage may occur if the appropriate precautionary measures are not followed!
 Caution
Places with this sign signify that small bodily injury or slight property damage may occur if the appropriate precautionary measures are not followed!

 Places with this sign provide technical information and tips on usage that damage to the machine must be avoided. This symbol is not a safety indication.

 Places with this sign provide information about possible hazards to the environment

 Please notice that a safety symbol never can replace the text of the safety instruction itself - the text of the safety instruction must be read entirely!

1.2 General safety instructions

This manual contains basic instructions which are to be observed in transport, assembly, start-up, operation, maintenance, shut-down, storage and waste disposal.

The following safety instructions have to be observed while operating the compact booster unit:

- When using the compact booster unit, the data, operation and usage conditions specifically authorised in the technical data sheet and the operating manual have to be observed.
- Never exceed the permissible limits pertaining to pressure, temperature, etc. as stated in the documentation.
- Observe all safety instructions as well as the operating instructions of the manual.
- Instructions that are directly attached to the system have to be observed and must be kept completely legible. This applies for example to:
 - Safety instructions
 - Arrow for rotation direction
 - Connection labels
 - Type label
- Before assembly and start-up, the manual has to be read by the operator as well as by the responsible technical/operating personnel and has to be stored at the site of the compact booster unit at all times.
- Installation and maintenance work may only be performed by authorised specialist personnel with the appropriate tools.
- The technical condition of the compact booster unit has to be checked regularly (at least once a year) by the operating company.
- The local safety and accident regulations have to be observed when operating the compact booster unit.
- The general technical rules must be observed when planning the usage and operating the device.
- Modification of the compact booster unit is not permitted and leads to the loss of warranty.
- After an interruption of the electrical or fluid supply, a defined or controlled re-run of the process must be ensured.
- The operator is responsible for complying with local regulations that are not covered by the manual.

1.3 Further safety regulations

Besides the safety instructions presented in this manual and its intended use, the following safety regulations are valid:

- Accident prevention regulations, safety and operating regulations
- Safety regulations for handling hazardous substances
- Applicable standards and laws

1.4 Unauthorised operation types

The limits that are stated in the documentation have to always be complied with. The delivered system is only guaranteed to operate reliably when it is used as intended.

1.5 Residual dangers in handling the compact booster unit

Danger and adverse effects may result from use of the compact booster unit

- for the body and life of the operator or third person
- for the compact booster unit itself
- to other property.

The basis for safe and error-free operation of the compact booster unit is knowledge of the instructions for safety and operation in this manual.

1.5.1 Mechanical residual dangers

During normal operation, no danger is threatened from mechanical components.

1.5.2 Residual dangers pertaining to fluids

During normal operation, no danger is threatened by hydraulic components.

Hazards might result solely under the following conditions.

Danger area	Type of hazard	Reduction of hazard
Pipelines	Injury through high pressure	Clear pipelines of pressure and medium prior to assembly, maintenance, shut-down!

1.5.3 Residual electrical hazards

During normal operation, no danger results from the electrical equipment of the compact booster unit.

Hazards might result solely under the following conditions.

Danger area	Type of hazard	Reduction of hazard
Injury from cables	Danger to life ! Electric shock of 230/400V from electric voltage	Connect up protective earth system! Always switch off power supply and secure against switching on again during maintenance and servicing work! Comply with the valid accident prevention and safety regulations for electrical devices!
Electrostatically endangered components / subassemblies	The device contains electronic componental elements that react sensitively to electrostatic discharge (ESD). Contact with electrostatically charged persons or objects endangers these componental elements. Worst case scenario: they will be immediately destroyed or fail after start-up.	Comply with requirements according to EN 100 015 - 1, in order to minimise or avoid damage through shock-type electrostatic discharge! Do not touch electronic componental elements when the power supply is on!

1.5.4 Residual biological hazards

During normal operation, no biological danger results from the compact booster unit.

Hazards might result solely under the following conditions.

Danger area	Type of hazard	Reduction of hazard
Buffer tank	Danger of microbial contamination	Clean the buffer tank regularly!

1.5.5 Residual chemical hazards

During normal operation, no chemical danger results from the compact booster unit.

Hazards might result solely under the following conditions.

Danger area	Type of hazard	Reduction of hazard
Use of detergents	Danger through contact with or breathing in dangerous fluids, gases, fumes, vapours or dust	Wear personal safety equipment! Pay attention to the safety specifications sheet of detergent manufacturers!

1.5.6 Consequences and dangers that result from not observing the manual

- Not observing this manual will lead to loss of the warranty and make damage claims invalid.
- Failure to observe the manual can lead, for example, to the following dangers:
 - Hazard to persons caused by electrical, thermal, mechanical, and chemical influences
 - Loss of important product functions
 - Failure to perform required maintenance and service measures
 - Environmental hazard caused by leakage of hazardous substances

1.6 Basic Safety Measures

1.6.1 Keep information available

This manual has to be stored. It has to be ensured that all persons who operate the compact booster unit have access to the manual at all times.

1.6.2 For environmental protection



When operating or servicing the compact booster unit, the regulations concerning waste avoidance and the proper recycling or disposal of waste must be observed.

Particular attention must be paid that materials and agents dangerous to the groundwater such as fats, oils, coolants, solvent-based liquid detergents, etc. do not pollute the ground or access the sewage system. These materials must be caught in suitable tanks, stored, transported and properly disposed of.

1.6.3 Modifications to the compact booster unit

When using externally procured parts, there is no guarantee that these are designed and constructed to tolerate demands made upon them or whether they comply with safety regulations.

For safety reasons, no unauthorised modifications may be made to the compact booster unit.

Parts and special equipment not delivered by Resideo are also not authorised by Resideo for use.

1.7 Duty of due care of the operator

This compact booster unit was designed and constructed according to a risk assessment and after careful selection of the harmonised standards that apply, as well as according to further technical specifications. It thus complies with best practice and guarantees the highest safety standard. This level of safety can only be attained during operational practice if all required safety measures have been taken. It is the duty of care of the operator of the compact booster unit to plan these measures and enforce their implementation.

In particular, the operator must ensure that

- the compact booster unit is only operated as intended
- the compact booster unit is only operated in perfect working condition.
- the manual has to be kept legible at all times and stored on-site with the compact booster unit.
- the compact booster unit is assembled, commissioned, maintained, and shut down solely by sufficiently qualified and authorised personnel.
- this personnel is regularly instructed on all relevant questions of work safety and environmental protection, and has also read and understood the manual and particularly the safety instructions it contains.
- none of the safety and warning signs attached to the compact booster unit are removed and all remain legible.
- a hazard assessment (according to the Safety at Work Act § 5) is conducted to detect further hazards that may arise from the particular working conditions on-site where the compact booster unit is operated.
- all further information and safety instructions which arise from the hazard assessment process shall be summarised in operating instructions (according to the work equipment regulation § 6).
- the drain output lines are sufficiently dimensioned

1.8 Safety instructions for the operator/operating personnel

- Eliminate hazards caused by electrical energy (for details refer to the country specific regulations and/or local power supply companies).

1.9 Safety instructions for maintenance, inspections and assembly work

- Alterations or modifications of the system are only permitted with the consent of the manufacturer.
- Use only original parts or parts authorised by the manufacturer.
- Use of parts other than those authorised may lead to loss of liability for any damage they may cause.
- Perform service on the system only when the machine is off.
- The pump housing has to be at ambient temperature.
- The pump housing has to be depressurised and empty.
- The procedures described in the manual for shutting down the system have to be observed under all circumstances.
- Reinstall safety equipment and protective devices and activate them again immediately after work on the system has been completed. Before starting up again, observe the start-up checklist.
- Keep unauthorised persons (e.g. children) away from the system.

1.10 Requirements for operating personnel

1.10.1 Operating personnel

This compact booster system may only be assembled, started, maintained, and shut down by persons who have been trained, instructed and authorised to do so.

In some cases, training can be arranged by the manufacturer if asked by the operator.

Training or personnel to operate system may only be conducted under the supervision of specialised technicians.

The relevant authorisations of the personnel are to be specified by the operating company in the form of an operating instruction.

Over and above this, special qualifications are required for the following tasks:

- Only electricians may perform work on electrical equipment.
- Assembly, maintenance, servicing and repair work may only be performed by qualified, specialist personnel

The basic regulations on work safety and accident prevention are to be observed.

1.10.1.1 Qualified personnel

Qualified personnel are persons who on account of their training, experience and instruction also their knowledge of the relevant norms, regulations, accident prevention regulations and operating conditions, including those persons responsible for the safety of the system, have been authorised to perform the relevant and required tasks, meanwhile being able to recognise and avoid dangers. This includes required knowledge of First Aid measures and the local ambulance services and facilities.

1.11 Personal safety equipment

No personal safety equipment is required to operate the compact booster unit.

2. General information

The manual is a part of the series and the versions as mentioned on the title page. The manual describes the safe and proper use in all modes of operation.

The type label indicates the series and size, the most important operating data and the order number. The factory number/serial number describes the identifies the system uniquely and serves this purpose for all further business transactions.

In order to maintain the warranty, in the event of damage immediately contact the nearest Resideo service centre.

2.1 Conformity with the following norms

Pump unit: Machinery Directive 2006/42/EG

Pump unit: EMC Directive 2004/108/EG

Frequency inverter: EMC Directive 2004/108/EG

Frequency inverter: Low voltage directive 2006/95/EG

2.2 Warranty and liability

As a matter of principle, the general sales and delivery terms of the Honeywell Company apply. Warranty and liability claims for injury to persons and damage to property are ruled out if they arise from one or more of the following causes.

- Non-intended use of the compact booster unit
- Improper assembly, start-up, operation and maintenance of the compact booster unit
- Failure to comply with the instructions in the manual concerning transport, storage, assembly, start-up, operation, maintenance, and service of the compact booster unit
- Unauthorised constructional modifications of the compact booster unit
- Improperly performed repairs
- Catastrophes through effect of a foreign object or force majeure

2.3 Storage and perfect condition

This instruction manual is a part of the compact booster unit and has to be complete and accessible at all times. Any instruction or page that is missing has to be replaced immediately.

2.4 Illustrations

The illustrations used are examples of one possible version of the compact booster unit and might differ in individual cases from the actual compact booster unit version.

2.5 Symbols

1. Start of a task description
2. Next work step
 - Result of an action
 - List of several options
- ☒ Reference to other documents

Pictogram	Danger classification
	<input type="checkbox"/> Danger source
	<input checked="" type="checkbox"/> Consequence of non-compliance
	<input type="checkbox"/> Avoidance

2.6 Other applicable documents

- ☒ Operating manuals, circuit diagram and further documentation of auxiliary equipment and integrated machine parts
- ☒ Product data sheet CBU140
- ☒ Operating instructions of the operating company
- ☒ Data sheets
- ☒ Declaration of Conformity

2.7 Glossary

EN 1717

European standard that specifies technical regulations for potable water installations.

Noise expectancy values

The expected noise emission, stated here as sound pressure level (SPL) in dB(A).

Certificate of no objection

A certificate of no objection is a declaration that the system has been cleaned properly so that parts that have been in contact with medium are not dangerous for health and environment.

3. Description

Fully automatic, ready-for-connection compact booster unit consisting of a single pump unit and a supply container for hygienic separation of drinking water and liquids of category 5 (agricultural businesses, slaughter houses, biological laboratories, sub-surface sprinkling systems) according to EN 1717.

The system has a mechanical floating valve in the inlet and can be switched on and off as required. The compact construction allows for installation in narrow supply rooms. The system comes ready to plug in and is equipped with a pump control and additionally a pressure gauge. A membrane-based pressure expansion vessel, included in delivery, must be installed in the pressure lines and serves to reduce the frequency of operation. The compact booster unit is a separation of systems as a means to protect drinking water from being contaminated by liquids of category 5 according to EN 1717.

The compact booster unit is a separation of systems as a means to protect drinking water from being contaminated by liquids of category 5 according to EN 1717.

Pump medium	Drinking water Without aggressive, abrasive and solid components
Flow rate	up to 4m ³ /h, 1.1 l/s
Pumping head	up to 43 m
Operating pressure	max. 6 bar Pre- and pumping pressure must not exceed 6bar.
Switch-on pressure pumps	2.5 bar
System pressure p _d	max. 6 bar
Prepressure pumps p _{before}	max. 1 bar
Prepressure drinking water backfeed	max. 4 bar
max. amount of drinking water backfeed at 4bar	approx. 1 l/s
Medium temperature	max. 35 °C
Supply voltage	230 V AC ± 10 %, 50 Hz
Power consumption in stand-by mode	2.5 - 3 W
Drive	Single-phase, a.c. motor 230V, with built-in circuit protector Direct online starting Thermal class F
Protective class	IP44
Weight CBU without water	approx. 22 kg
filled with water	approx. 35 kg
Weight Membrane pressure expansion vessel without water	approx. 2,4 kg
filled with water	approx. 5 kg

3.1 Pump Output

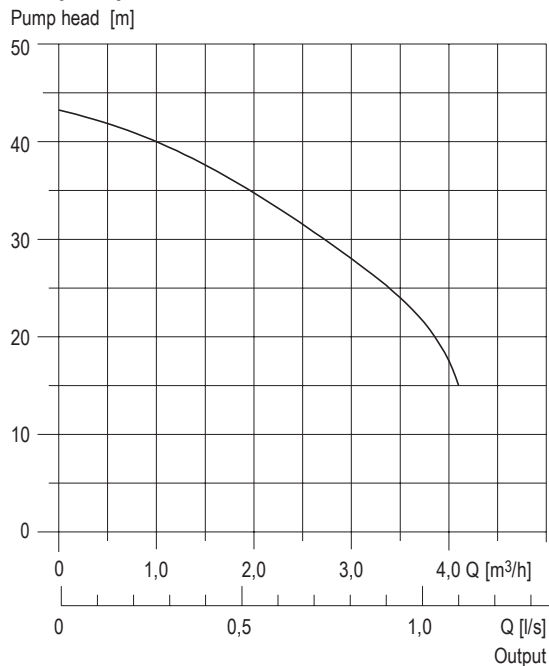

3.2 Backfeed for 3/4" pipes

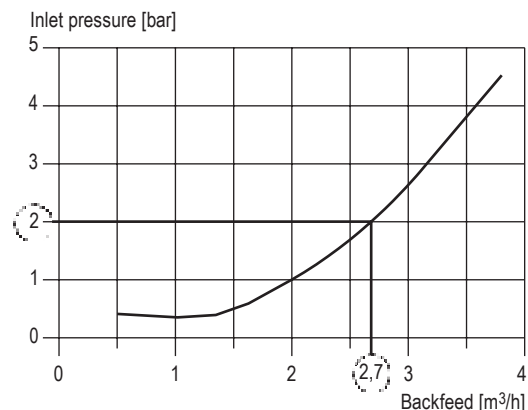

3.3 Noise expectancy values

Noise levels based on the systems pumping data result in nearly 55 dB(A).

3.4 Authorised environmental conditions

Ambient temperature	5°C ...40°C
Relative air humidity	max. 50% r.h.

3.5 Type label

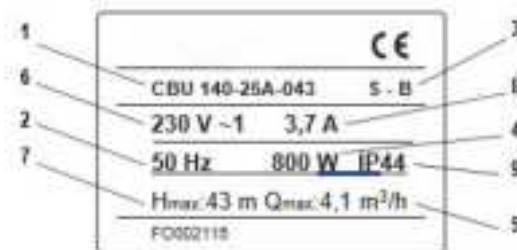

1	Series	6	Rated voltage
2	Frequency	7	max. pumping head
3	Serial number	8	max. power input
4	Power output	9	Protection class
5	max. feed rate		

Key for the serial number

Calendar year	2009	2010	2011	2012	2013
1st half-year	S-U	S-W	S-Y	S-A	S-C
2nd half-year	S-V	S-X	S-Z	S-B	S-D

3.6 Version

Plug-in ready compact booster unit, consisting of:

- self-priming multi-stage centrifugal pump
- monitoring and control unit for the centrifugal pump
- system control
- backfeed tank with integrated drinking water backfeed via mechanical floating valve and free outlet according to EN 1717
- fastening set for wall mounting, consisting of screws, wall plugs and mounting bracket
- flexible expansion joint connection PN10 with DVGW-/TÜV approval and 10-year guarantee for the pressure side as well as the drinking water connection (length approx. 30/50 cm)
- Membrane pressure expansion vessel
- Installation manual with mounting template

3.7 Overview

In an angular tank designed for wall mounting there is a multi-stage high-pressure pump. The high-pressure pump is connected via bent tube to an inlet, which leads to the supply tank.

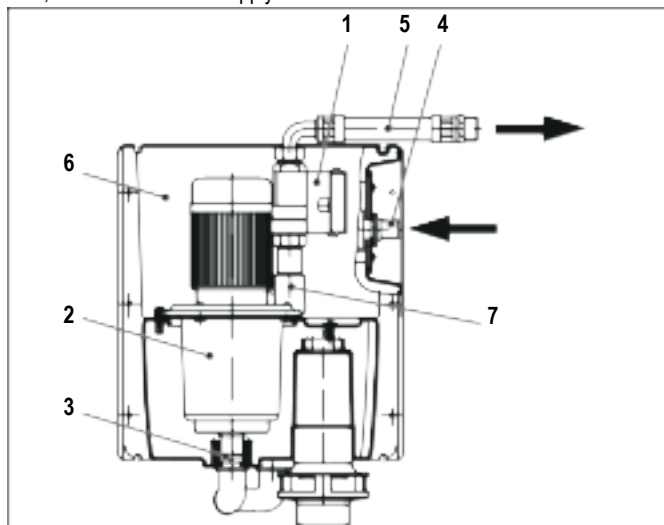

Figure 1: CBU140 Structure

- | | |
|-----------------------------|---------------------|
| 1 Pump control | 5 Pressure delivery |
| 2 Pump | 6 Tank |
| 3 Inlet tank | 7 Vent valve |
| 4 Drinking water connection | |

3.7.1 Installation type

- Fixed installation

3.8 Intended use

The compact booster unit may only be operated in such areas as described in the other applicable documents.

Non-intended operation of the compact booster unit can result in danger to persons, systems, the surroundings and the environment.

- Operate the compact booster unit only if it is in perfect working condition.
- Do not operate the compact booster unit if it is only partially assembled.
- The compact booster unit may only be used to pump the medium as described in the documentation of the respective version.
- Never operate the compact booster unit without pump medium.
- Observe the values for minimum pumping rates (avoiding damage because of overheating, storage damage, ...).
- Observe the values for maximum pumping rates (to avoid damage due to overheating, floating ring seal damage, cavitation damage, storage damage, ...).
- Do not throttle the input of the compact booster unit (to avoid cavitation damage).
- Other modes of operations, if not mentioned in the documentation, have to be coordinated with the manufacturer.

3.9 Non-intended use

The compact booster unit is not designed for operation outside. Temperature, light and moisture can lead to malfunctions and damaging devices.

- Do not operate the compact booster unit outside.
- Operate the compact booster unit only as intended.
- Do not fill aggressive or flammable medium into the medium lines of the system.
- No mechanical stress on housings (e.g. by depositing objects or as a step).
- Do not perform any external modifications on the device housing. Do not paint housing parts and screws!
- Do not disassemble the compact booster unit more than is necessary for purposes of installation and maintenance.

3.10 Options

CBU140-25A-043	Connection size DN25, Pumping head 43 m
----------------	---

4. Function

The self-priming system draws in the pumping medium from an angular tank via the inlet. In this tank there is a water supply of approx. 13 Litre, which is automatically filled and refilled from the drinking water network via floating valve. The pump is turned on and off automatically when a consumer is opened.

For monitoring there is a pump control in the pressure lines of the system, which turns the pump on when the pressure drops below approx. 2.5 bar (factory setting). When the consumer is closed, the pump is then turned off with a delay of approx. 10 seconds. This device simultaneously protects the pump from dry running. A check valve in the pump control prevents back-flow. The pressure is read from a built-in pressure gauge.

4.1 Construction dimensions

CBU

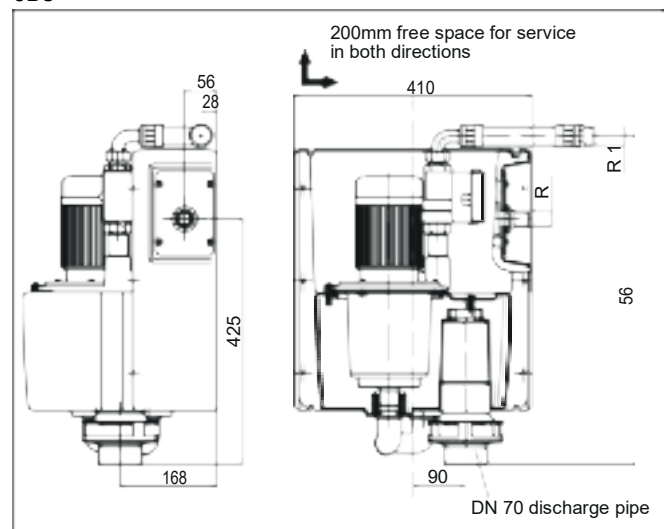

Membrane pressure expansion vessel

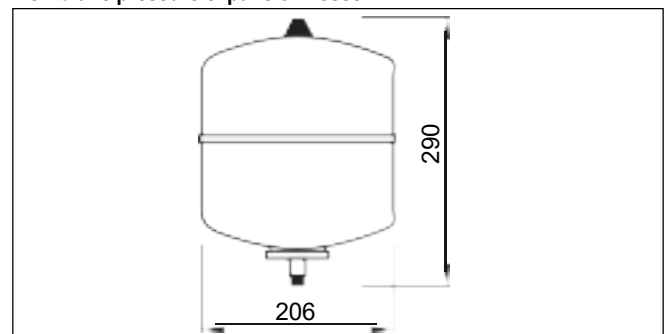

5. Shipping

5.1 Check condition upon delivery

1. Check the contents of each package for damage upon delivery.
2. In the case of transport damage estimate the extent, document the damage and notify Resideo immediately in writing.

5.2 Transportation

Danger
<ul style="list-style-type: none"> <input type="checkbox"/> The system falls off of the pallet <input checked="" type="checkbox"/> Danger of being crushed by system! <ul style="list-style-type: none"> <input type="checkbox"/> Position the system vertically during transport <input type="checkbox"/> Never get the system tangled in electrical lines. <input type="checkbox"/> Observe the local safety regulations. <input type="checkbox"/> Observe the weight and mass centre. <input type="checkbox"/> Only use appropriate and authorised means of transportation, for example fork lift or hand lift.
Warning
<ul style="list-style-type: none"> <input type="checkbox"/> Installation on non-level and non-structural installation sites <input checked="" type="checkbox"/> Personal and property damage! <ul style="list-style-type: none"> <input type="checkbox"/> Ensure sufficient compressive strength according to class C12/15 for concrete in the exposition class X0 according to EN 206-1. <input type="checkbox"/> The installation site has to be solid, level and horizontal. <input type="checkbox"/> Observe the weight information.

i The compact booster unit is attached to wooden rails and wrapped in foil for transport and temporary storage. All connection interfaces have protective lids.

The system is on a small wooden pallet under the telescope box. Accessories are packed in the same box - see the box label. Two carrier handles for transport are in the box.

1. To unpack, cut the packaging straps.
2. Take the accessories and the extra padding out of the box.
3. Lift the box upwards.
 - The system stands alone on the wooden pallet.
4. Check the contents of the package for completeness.
5. Check the system for transport damage.
6. Select the appropriate means of transport.
7. Transporting the system to the installation site.

6. Assembly

6.1 General safety instructions

Danger
<ul style="list-style-type: none"> <input type="checkbox"/> Danger of injury from electric voltage. <ul style="list-style-type: none"> <input checked="" type="checkbox"/> High shock currents and burns from direct and indirect contact with live parts. <ul style="list-style-type: none"> <input type="checkbox"/> Turn off the power supply before assembling the compact booster unit and secure it from being turned on.
<ul style="list-style-type: none"> <input type="checkbox"/> Faulty mains connection <ul style="list-style-type: none"> <input checked="" type="checkbox"/> Damage to the electricity network, short circuit! <ul style="list-style-type: none"> <input type="checkbox"/> The electrical system must conform with the installation regulations according to VDE 100 (i.e. grounded electrical sockets). <input type="checkbox"/> The electrical network must be equipped with a residual current device for max. 30mA.
<ul style="list-style-type: none"> <input type="checkbox"/> Non- or erroneously-connected cables <ul style="list-style-type: none"> <input checked="" type="checkbox"/> Malfunctions, which endanger the safety of operating personnel. <ul style="list-style-type: none"> <input type="checkbox"/> Work on electrical equipment may only be performed by specialist electric technicians.
<ul style="list-style-type: none"> <input type="checkbox"/> Improperly connected wiring and lines (e.g. too small bend radius) <ul style="list-style-type: none"> <input checked="" type="checkbox"/> Smouldering and fires from cables. <ul style="list-style-type: none"> <input type="checkbox"/> Work on electrical equipment may only be performed by specialist electric technicians.
<ul style="list-style-type: none"> <input type="checkbox"/> Live cable ends and components <ul style="list-style-type: none"> <input type="checkbox"/> Make sure the protective earth system is connected throughout.
Warning
<ul style="list-style-type: none"> <input type="checkbox"/> The compact booster unit is not designed for operation outside. <ul style="list-style-type: none"> <input checked="" type="checkbox"/> Temperature, light and moisture influences can lead to malfunctions and damage to devices. <ul style="list-style-type: none"> <input type="checkbox"/> Do not use the compact booster unit outside. <input type="checkbox"/> Danger through improper installation <ul style="list-style-type: none"> <input checked="" type="checkbox"/> Personal and property damage! <ul style="list-style-type: none"> <input type="checkbox"/> Performance of tasks only by qualified personnel (see section 1.10.1.1).
Caution
<ul style="list-style-type: none"> <input type="checkbox"/> Damaged or improperly installed compact booster unit. <ul style="list-style-type: none"> <input checked="" type="checkbox"/> Malfunctions <ul style="list-style-type: none"> <input type="checkbox"/> Do not damage the compact booster unit and only install it if it is clean and fully functional. <input type="checkbox"/> Install the compact booster unit according to the described instructions. <input type="checkbox"/> Install free of voltage and of bending moments. <input type="checkbox"/> Connecting cable overly bent <ul style="list-style-type: none"> <input checked="" type="checkbox"/> Defective system due to improper load on the system <input checked="" type="checkbox"/> Reduction of service life! <ul style="list-style-type: none"> <input type="checkbox"/> Install connecting cable with zero potential. No load is allowed to be put on either the connections or the system. <input type="checkbox"/> Drinking water backfeed of max. 4bar exceeded <ul style="list-style-type: none"> <input checked="" type="checkbox"/> Defective system due to improper load <ul style="list-style-type: none"> <input type="checkbox"/> Install pressure reducing valve ahead of the system to ensure that not more than 4bar prepressure is fed from the drinking water network.

6.2 Installation according to EN1717

Accommodate the compact booster unit in a technical centre or in a frost-free, well ventilated, lockable room that is not used for anything else. Hazardous gases should never enter the installation room. A sufficiently dimensioned dewatering connection (drain connection or similar) is required (observe EN 12056).

Usable volume tank	Dewatering capacity
13 l	5,4 m ³ /h

Table 6: Usable volume/dewatering capacity

i Do not operate the compact booster unit near living rooms and bedrooms.

6.3 Inspection before assembly

Check the following points prior to installation:

- According to specifications on the type label, the system is suitable for the electric supply network.
- The medium to be pumped corresponds to the permissible pumping media
- The above-mentioned safety instructions have been observed.
- The installation room is dry, frost-free and well-ventilated.

6.3.1 Installation site

- I** Ideally select an outer wall for mounting. The wall must be able to take 4 wall plugs Ø 10mm and carry the weight of the system (approx. 35 kg when filled with water).

6.4 Installing the compact booster unit

- I** Make allowance for space for operating and maintenance tasks.

1. Remove the packaging before installing the system.
2. Mark the 4 mounting points using the drilling template included.



3. Drill holes (4 x Ø10mm).
4. Insert suitable, proper sized dowels.
 - wall plugs included only for mounting in concrete and full brick walls.
5. Mount and adjust both of the lower fixing attachments.
6. Set the system in both of the lower fixing attachments.
7. Mount upper fixing attachments.

6.5 Installing the pipelines

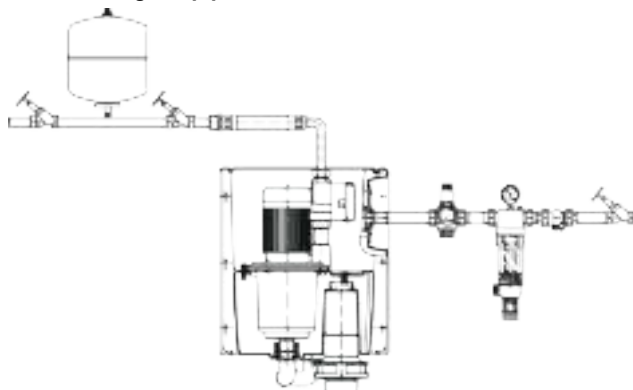

- I** Install connecting cable with zero potential. No load is allowed to be put on either the connections or the system. Install pressure reducing valve ahead of the system to ensure that not more than 4bar prepressure is fed from the drinking water network. It is recommended to install a stop valve and an external filter.

6.5.1 Water connection

1. Attach inlet connection R 3/4" with flexible pressure hose to the drinking water line.
2. Fill angular tank with water.
3. Open drinking water line.
 - After opening the drinking water line, the tank is automatically filled.

6.5.2 Pressure connection

- I** Avoid overly bending the flexible connecting pipe, as this reduces the service life and puts an improper load on the connections. To avoid frequently pump activation for small withdrawal amounts, install membrane pressure expansion vessel downstream of the CBU. A membrane pressure expansion vessel is included in scope of delivery. It is recommended to install a stop valve.
1. Install membrane pressure expansion vessel in consumption water line. Set pre-pressure to 3,2 - 3,4 bar. For filling use nitrogen only!
 2. Connect the system to the consumption water line using the flexible pressure hose.

6.5.3 Connecting the overflow

⚠ Caution

- Overflow not connected
- Danger of flooding the installation room!
 - ↳ Lead the overflow line to a drain with adequate dewatering capacity (connection DN70).

An overflow for free drain as prescribed by EN 1717 is implemented, and has a nominal width of 70mm for this system. This overflow becomes effective when the drinking water backfeed leaks and the water exceeds the maximal overflow point.

- I** The absence of backwater prevention due to the wastewater system leads to the loss of DVGW-approval! If the systems overflow funnel is missing, the system must be connected to the wastewater system with an overflow siphon found in the accessories. In doing so, it must be ensured that the overflow siphon is not firmly connected to the system and that the installation is performed according to DIN 1986-100, EN 1717. With a secure connection to the wastewater system, we recommend the installation of a siphon to avoid unpleasant odour.

1. Connect the overflow.

6.6 Electrical connection

6.6.1 Safety instructions

⚠ Danger

- Danger of injury from electric voltage.
 - High shock currents and burns from direct and indirect contact with live parts.
 - ↳ Turn off the power supply before assembling the compact booster unit and secure it from being turned on.
- Faulty mains connection
 - Damage to the electricity network, short circuit!
 - ↳ The electrical system must conform with the installation regulations according to VDE 100 (i.e. grounded electrical sockets).
 - ↳ The electrical network must be equipped with a residual current device for max. 30mA.
- Non- or erroneously-connected cables
 - Malfunctions, which endanger the safety of operating personnel.
 - ↳ Work on electrical equipment may only be performed by specialist electric technicians.
- Improperly connected wiring and lines (e.g. too small bend radius)
 - Smouldering and fires from cables.
 - ↳ Work on electrical equipment may only be performed by specialist electric technicians.
- Live cable ends and components
 - ↳ Make sure the protective earth system is connected throughout.

- I** The installation of a motor protection device is recommended.

1. Compare the mains voltage with the specifications on the type label.
2. Insert mains plug in the electrical socket.

6.7 Verification of the waterflow

The water shortage monitor must not be activated at maximal withdrawal. Should the water shortage monitor nevertheless be activated, then the pressure side must be throttled. For maximum withdrawal and backfeed amounts see chapter description.

7. Start-up

i Performance of tasks only by qualified personnel (see section 1.10.1.1).

7.1 Safety instructions for start-up

Warning	
<input type="checkbox"/>	Danger from improper operation.
<input checked="" type="checkbox"/>	Malfunctions <ul style="list-style-type: none"> <input type="checkbox"/> Before starting, the manual has to be read by the operator as well as by the responsible technical/operating personnel and has to be stored at the site of the compact booster unit at all times. <input type="checkbox"/> Adhere to local safety and accident regulations when starting the compact booster unit.
<input type="checkbox"/>	Damaged or improperly installed compact booster unit.
<input checked="" type="checkbox"/>	Malfunctions <ul style="list-style-type: none"> <input type="checkbox"/> Check the compact booster unit for obvious signs of damage; eliminate any defects immediately or alert the supervising personnel. The compact booster unit may only be operated in perfect working order.

Inform yourself sufficiently about

- the equipment of the compact booster unit
- the functionality of the compact booster unit
- the close surroundings of the compact booster unit
- the measures to be taken in an emergency

7.2 Start-up requirements

Caution	
<input type="checkbox"/>	Dry running pump
<input checked="" type="checkbox"/>	Damage to the pump/system! <ul style="list-style-type: none"> <input type="checkbox"/> Ensure that there is no water shortage.

Before start-up of the compact booster unit, the following points have to be ensured:

- The compact booster unit has to be connected to all protective equipment according to the regulations.
- The relevant VDE and country-specific regulations have to be adhered to and fulfilled.
- Connection of the drinking water backfeed is connected to the drinking water network.
- The systems electrical connections have been made according to regulations.

7.3 Fill up and vent the pump and tank

1. Set the operating mode switch to **drinking water backfeed** for approx. 15 seconds.
 - The system tank is filled automatically.
2. Open the air bleed valve with a screwdriver or a square spanner.
3. Wait until water leaves the air bleed valve.
 - When water leaves the air bleed valve, the system has been vented.
4. Close air bleed valve.
5. Open a consumer.
6. Turn the pump briefly on.

7.4 Switching the system on

The system is automatically turned on, when the mains plug is inserted.

7.5 Function check

The system is set up, installed, connected and started according to specifications.

7.5.1 Checking the protection against dry running

1. Close the suction-side inlet.
 - The system is continuously monitored for dry running by the pump control. If not enough pump medium is fed into the system (the flow stalls), the pump control shuts down after 10 to 15 seconds. By pressing the Reset-key, the follow-up time can be reactivated.

7.6 Start-up checklist

Work steps		finished
1	Read instructions.	
2	Check the voltage supply and compare with the values on the type label.	
3	Check the mechanical connection to the water supply system. Tighten the flanges and the screws.	
4	Fill and ventilate the compact booster unit from the input side.	
5	Check the refilling.	
6	Check protection against dry running	
7	Check the operating mode	
8	Circumstances regarding the system that are not the same as stated in our documentation or ordering data, have to be noted in the start-up protocol.	
9	Fill out the start-up protocol with the operator and show the operator how the machine functions.	

8. Operation

The pump is turned on automatically when a consumer is opened.

The pump is functioning.

If all consumers are closed, then the pump shuts down automatically.

In case of water shortage, the integrated protection against dry running shuts the pump down automatically.

The red light comes on in case of water shortage or malfunction.

With the Reset-key, the malfunction message can be reset.

As long as the Reset-key is pressed, the control unit is in manual operation mode.

9. Maintenance

- I** Maintenance should be performed by Resideo technical staff.
- If necessary contact the service department at Resideo. Performance of tasks only by qualified personnel (see section 1.10.1.1).

9.1 Safety instructions for maintenance

Danger
<input type="checkbox"/> Danger of injury from electric voltage. <input checked="" type="checkbox"/> High shock currents and burns from direct and indirect contact with live parts. <input type="checkbox"/> Turn off the power supply before maintaining the compact booster unit and secure it from being turned on.
Warning
<input type="checkbox"/> Unqualified persons working on the compact booster unit <input checked="" type="checkbox"/> Danger of injury! <input type="checkbox"/> Only let specially qualified personnel perform repair and maintenance work.
Caution
<input type="checkbox"/> Inappropriately maintained compact booster unit <input checked="" type="checkbox"/> The proper function of the compact booster unit can no longer be ensured! <input type="checkbox"/> Maintain the compact booster unit regularly.

- Always observe the safety regulations and instructions.
 Observe the instructions for working on the pumps.

- I** In case of damage, please contact our service department. By setting up a maintenance schedule, the required maintenance to avoid expensive repairs and achieve fault-free and reliable functioning of the compact booster unit is held to a minimum.

9.2 Overview of inspection tasks

Interval	Operation
semi-yearly	Check pump control
	Check protection against dry running
	Check pressure hoses
	Check floating ring seal

9.3 Inspection

- I** To ensure that the compact booster unit can be operated reliably, the required inspections have to be conducted on time.

9.3.1 Check protection against dry running

- I** Interval: semi-yearly

1. Close off drinking water backfeed.
2. Activate a consumer to pump the supply tank empty.
 - When the supply tank is empty, the pump control has to shut the pump down within 10 - 15 seconds. A restart occurs only after pressing the Reset-key.

9.3.2 Check pressure hoses

- I** Interval: semi-yearly

1. Check pressure hoses for leaks and damage to the metal braiding.
 - The hoses are to be replaced in case of leaks or severe damage to the metallic sheath.

9.3.3 Check pump control

- I** Interval: semi-yearly

1. Open consumer.
2. Ensure that all consumers are closed.
3. The pump must shut down after approx. 10 - 15 seconds after all consumers are closed.

9.3.4 Check floating ring seal leakage

- I** Interval: semi-yearly

- I** Slight wear of the floating ring seal is unavoidable and is accelerated by abrasive particles in the pumping medium.

1. Check for leakage in the area between motor and pump housing.
2. In case of leakage the floating ring seal must be replaced.
 - The replacement should be performed by Resideo technical staff.

9.3.5 Check preload pressure of membrane pressure expansion vessel

- I** Interval: semi-yearly

1. Remove protection cap.
2. Check preload pressure. If necessary, set to 3.2 - 3.4 bar.

9.4 Maintenance

- I** Maintenance should be performed by Resideo technical staff.

10. Troubleshooting

I During the warranty period consult the manufacturer before performing maintenance work on the system (only work that is required for start-up and maintenance).

Our customer service department is at your service. Failure to comply will lead to loss of any liability claims.

Errors	Possible cause	Elimination	by
Pump is running but does not suck	Pump is not full	Fill pump	User
	Tank inlet closed	Open tank inlet	User
Pump turns frequently on and off	Leaky consumer	Seal consumer	User
Pump is running, feed rate or pressure are not sufficient	Pump draws in air	Suction line check	User
Pump shuts down during operation and indicates malfunction	Power outage or undervoltage	Check power supply	User
	Thermo switch has triggered due to overheating	Check that pump moves freely	Service
	ELCB (earth leakage circuit breaker) has triggered	Have insulating resistance checked by a trained electrician	Service
System does not turn on	Pump control indicates malfunction	Press Reset-key or disconnect mains voltage	User
System does not turn off	Foreign particles in pump control	Clean pump control and replace if necessary	Service
System is too loud	Pump lies against the safety screws	Adjust pump by hand, so that the pump is not lying against the screws	User
Tank overflows	Contamination in valve	Eliminate dirt/limescale in valve and replace floater if necessary	Service

10.1 Measures for elimination of pressure surges

10.1.1 Enlargement of the inlet line

According to DIN 1988, Part 3, for amounts > 0.5l/s a minimal pipe inner diameter of 20mm is to be selected.

10.1.2 Setting pressure reducing valve

If static pressure of 5bar can be read on the pressure gauge and the pressure drops to 2.5bar when the valve is opened, then the static pressure must be lowered by 1bar. Pressure surges occur by pressure differences larger than 2bar.

10.1.3 Throttle pressure surge

If a stop valve or pressure reducing valve is installed in the drinking water line upstream of the system, then it has to be throttled until the pressure surge disappears. The disadvantage of this method is the small feed amounts. It must be checked, whether the feed amount is sufficient for normal use. The water shortage monitor, however, must not be activated at maximal withdrawal. Should the water shortage monitor nevertheless be activated, then the downstream side must be throttled as well.

10.1.4 Membrane pressure expansion vessel

Install an 8l - membrane pressure expansion vessel in the line ahead of the system inlet. With this container, severe pressure drops from thin lines are diminished and surges are contained without throttling the amount.

11. Shut-down, disassembly, restart

11.1 Shutting down the compact booster unit

 Danger
<input type="checkbox"/> Danger of injury from electric voltage. <input checked="" type="checkbox"/> High shock currents and burns from direct and indirect contact with live parts. <input type="checkbox"/> Turn off the power supply before shut down the compact booster unit and secure it from being turned on.

1. Disconnect system from the electric power supply and secure against being started.
2. Dismantle the system properly.
3. Close drinking water inlet and pressure line.
4. Rinse the system properly.
5. Let system drain.

11.2 Restarting the compact booster unit



Please note the procedures in chapter 7.

12. Storage

12.1 Short-term storage

Short-term storage is possible without further preparation under the specified environmental conditions.

12.2 Storage/Preservation

 Caution
<input type="checkbox"/> Damage during storage caused by frost, humidity, dirt, UV radiation or pests <input checked="" type="checkbox"/> Corrosion/Contamination of the system! <input type="checkbox"/> Protect the system against frost, do not store outside.
 Caution
<input type="checkbox"/> Damp, dirty or damaged openings and junctions <input checked="" type="checkbox"/> Danger of leaks and damaging the system! <input type="checkbox"/> Uncover openings in the system only during installation.

12.3 Storage conditions

Storage location	closed room, dry and dust-free
Ambient temperature	5°C to 40°C
Relative air humidity	max. 50% r.h.

13. Disposal



It is imperative to observe the laws and regulations on waste disposal of materials that are detrimental to the environment.

Such materials include old oils, coolants, paint, plastics and chemicals. If in doubt, consult the manufacturer.

1. Disassembly of the system.
 - Collect grease and lubricants during disassembly.
2. Separate the pump materials for example according to:
 - Metal
 - Plastic
 - Electronic junk
 - Grease and lubricants
3. Dispose according to local regulations or have them disposed of according to regulations.

14. Spare Parts

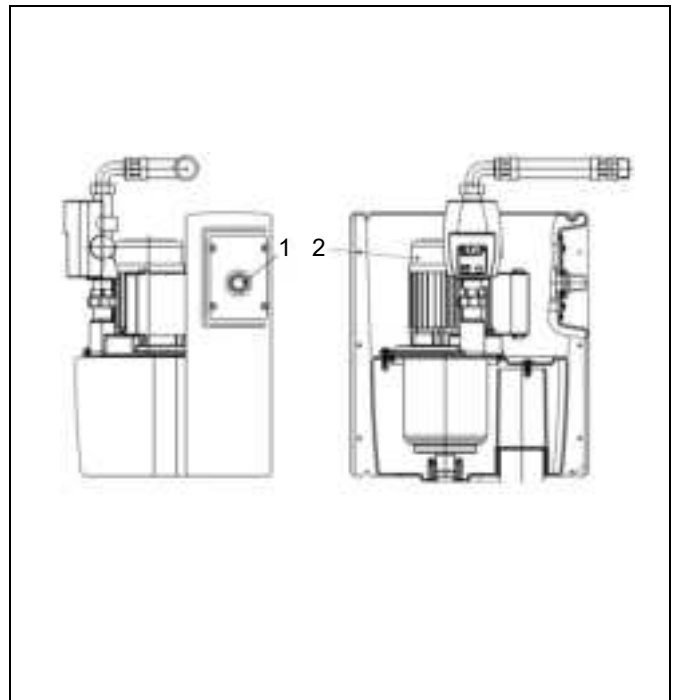

Compact Booster Unit / single pump CBU140
(from 2013 onwards)

No.	Description	Part No.
1	Float valve (complete)	18040893-CBU
2	Pump incl. set of seal elements	18041119-CBU
3	Pump drive	18041125-CBU
4	Seal set	18040824-CBU

15. Start-up protocol

The following Resideo Compact Booster Unit was commissioned today by the signatories, authorised the Resideo customer service staff, and this protocol was written.

1 Compact booster unit

Series
 Size
 Serial number
 Order number

2 Customer/Operating site

Customer	Operating site
Name
Address
.....

3 operating data refer to circuit diagram for additional data

Switch-on pressure pE bar
 Monitoring the precharge pressure pbefore - X
 Setting value for the precharge pressureswitch
 Switch-off pressure pA bar
 Precharge pressure pbefore
 bar
 Precharge pressure tank pbefore
 bar

4 Important notes

According to the DVGW Process Sheet W 314, the company operating the system is obligated to inform the water distribution company responsible about the commissioning of the system.

If the system is additionally operated with group III/IV pressure vessels according to the regulation for such vessels, then the TÜV has to be informed as well.

The operating company or their customer hereby confirms being fully trained in operation and maintenance of the compact booster unit. The circuit diagrams and instructions were also delivered.

Defects determined during start-up

Scheduled elimination

Defect 1
.....
.....
.....

Name of Resideo customer

Name of supplier and contractor

.....

City

Date

.....



www.resideo.com

Ademco 1 GmbH
Hardhofweg 40
74821 Mosbach
Phone: +49 1801 466 388
info.de@resideo.com
homecomfort.resideo.com

@2020 Resideo Technologies,
Inc. All rights reserved.
This product is manufactured by
Resideo Technologies, Inc and
its affiliates.