



Invacare **3G Storm Series**[®]
Invacare **3G Storm Series Torque™ SP**
Invacare **3G Storm Series Torque 3**
Power Wheelchair Base

User Manual

EN

*This manual MUST be given to the user of the product.
BEFORE using this product, read this manual and save for future reference.*



Yes, you can.[®]

© 2016 Invacare Corporation. All rights reserved. Republication, duplication or modification in whole or in part is prohibited without prior written permission from Invacare. Trademarks are identified by ™ and ®. Making Life's Experiences Possible is a registered trademark in the U.S.A. All trademarks are owned by or licensed to Invacare Corporation or its subsidiaries unless otherwise noted.

1	GENERAL	6
	Symbols	6
	Reference Documents	7
	Restriction of Sale.....	7
	Indications for Use.....	7
	Intended Use.....	7
2	LABEL LOCATIONS	8
	All Wheelchairs	8
	Wheelchairs with O2 Holders.....	11
	Wheelchairs with TRRO.....	12
3	WEAR AND TEAR INFORMATION	13
	General Information	13
4	SAFETY	14
	General Guidelines	14
	Setup Guidelines.....	23
	Operation Guidelines.....	25
	Transport Guidelines	26
	Safety/Handling	27
5	ELECTROMAGNETIC COMPATABILITY (EMC) INFORMATION	44
	Electromagnetic Interference (EMI) From Radio Wave Sources.....	44
	Electromagnetic Interference (EMI).....	45
	Electromagnetic Emission.....	46
6	TECHNICAL DATA	47
	Specifications.....	47

CONTENTS

7	WHEELCHAIR OPERATION	51
	Operating the Wheelchair	51
	SPJ™ +, MK6i™ SPJ+ w/PSS and MK6i SPJ+ w/ACC Joystick Switches and Indicators	54
	CMPJ+ Joystick Switches and Indicators.....	57
	When to Charge Batteries	65
	Charging Batteries	67
	Disengaging/Engaging Motor Lock Levers	69
	Disengaging/Engaging the Wheel locks	70
8	TRANSPORT IN VEHICLES	71
	Wheelchair Transport Brackets (TRBKTS).....	72
	Transport Ready Option (TRRO).....	73
	Compliance Information.....	75
	Specifications.....	75
	Securing the Occupant	77
9	SETUP/MAINTENANCE	82
	Setup/Delivery Inspection	84
	User/Attendant Inspection Checklists	85
	Cleaning.....	87
	Service Inspection	88
	Batteries	90
	Using the Proper Batteries	92
	Recommended Battery Types.....	93
	Replacing Batteries	94
	Removing/Installing Battery Boxes	95
	Installing/Removing Batteries Into/From Battery Boxes	100

Battery Terminals..... 101

Disconnecting/Connecting Battery Cables 102

Installing Wheel Locks 106

Adjusting Wheel Locks..... 108

Adjusting Forks..... 109

Adjusting the Extended Active Anti-Tippers..... 110

Disconnecting/Connecting the Joysticks 112

10 TROUBLESHOOTING 114

Driving Performance 114

Electrical..... 114

Checking Battery Charge Level 120

11 DISPOSAL 121

Recycle..... 121

12 WARRANTY 122

Global Limited Warranty (Excluding Canada)..... 122

Canada Limited Warranty..... 123

I General

I.1 Symbols

Warnings

Signal words are used in this manual and apply to hazards or unsafe practices which could result in personal injury or property damage. See the information below for definitions of the signal words.



DANGER

Danger indicates an imminently hazardous situation which, if not avoided, will result in death or serious injury.



WARNING

Warning indicates a potentially hazardous situation which, if not avoided, could result in death or serious injury.



CAUTION

Caution indicates a potentially hazardous situation which, if not avoided, may result in property damage or minor injury or both.



IMPORTANT

Indicates a hazardous situation that could result in damage to property if it is not avoided.



Gives useful tips, recommendations and information for efficient, trouble-free use.

I.2 Reference Documents

Refer to the table below for part numbers of additional documents which are referenced in this manual.

MANUAL	PART NUMBER
MK6i™ Electronics Programming Guide	1141471
Adjustable ASBA User's Manual	1143192
3G Storm Series Base Service Manual	1104849
Formula™ CG Seating System	1143155
Adjustable ASBA Service Manual	1143238

I.3 Restriction of Sale

Federal law restricts this device to sale by/on the order of a physician licensed by the law of the state in which he/she practices.

I.4 Indications for Use

The intended use of the Invacare 3G Storm Series® Power Wheelchair is to provide mobility to persons limited to a sitting position, that have the capability of operating a powered wheelchair.

I.5 Intended Use

The intended use of the Invacare 3G Storm Series® Power Wheelchair is to provide mobility to persons limited to a sitting position.

2 Label Locations

2.1 All Wheelchairs



DANGER

Risk of Injury, Damage or Death

Missing or damaged labels may contribute to injury, damage or death
—Ensure labels are present and legible. Replace if necessary.



Labels are subject to change without notice.



The battery labels shown on this page and the next page are found on the inside of the battery box lids.

Group 24 Batteries Only

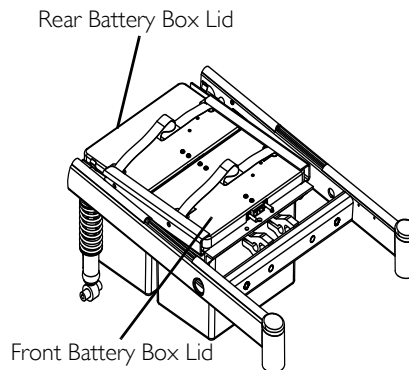
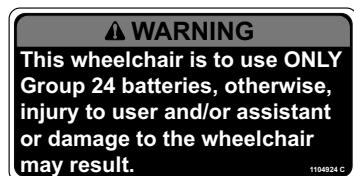

4 Pole Motors with Group 24 Batteries Only

1098361
DUAL GP24
Batteries

⚠ WARNING

The **POSITIVE (+) RED Battery Cable MUST connect to the POSITIVE (+) Battery Terminal(s)/Post(s).** The **NEGATIVE (-) BLACK Battery Cable MUST connect to the NEGATIVE (-) Battery Terminal(s)/Post(s).** **DO NOT** allow Battery Cable(s) to contact the opposite Battery Terminal(s)/Post(s). Replace cable(s) immediately if cable(s) insulation becomes damaged. Failure to observe these warnings may result in an electrical short with serious personal injury and/or damage to the electrical system. See Owner's Manual.

WIRING DIAGRAM for Dual GP24 Batteries

DO NOT remove this label. P/N 1098361 Rev B

Elevate Systems with Group 24 Batteries Only

⚠ WARNING

The **POSITIVE (+) RED Battery Cable MUST connect to the POSITIVE (+) Battery Terminal(s)/Post(s).** The **NEGATIVE (-) BLACK Battery Cable MUST connect to the NEGATIVE (-) Battery Terminal(s)/Post(s).** **DO NOT** allow Battery Cable(s) to contact the opposite Battery Terminal(s)/Post(s). Replace cable(s) immediately if cable(s) insulation becomes damaged. Failure to observe these warnings may result in an electrical short with serious personal injury and/or damage to the electrical system. See Owner's Manual.

WIRING DIAGRAM for Dual GP24 Batteries

DO NOT remove this label. 1143246 Rev A 09/25/06



Auto style seat positioning strap shown. This label is also on the airline style seat positioning strap.

⚠ WARNING

This seat/chest positioning strap is **NOT** intended for occupant restraint in a moving motor vehicle, and **DOES NOT** conform with ANSI/RESNA WC/19. If signs of wear appear, positioning strap **MUST** be replaced **IMMEDIATELY**.
P/N 1134811 REV B

MISE EN GARDE

Cette ceinture de positionnement au niveau du siège ou du dossier **N'EST PAS** conçue pour retenir l'occupant dans un véhicule à moteur en mouvement et elle **N'EST PAS** conforme à la norme ANSI/RESNA WC/19. La ceinture **DOIT** être remplacée **ALORS** qu'elle présente des signes d'usure.

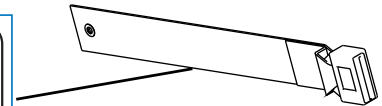

2 LABEL LOCATIONS

Serial number label is located on the inside of the front or rear frame.

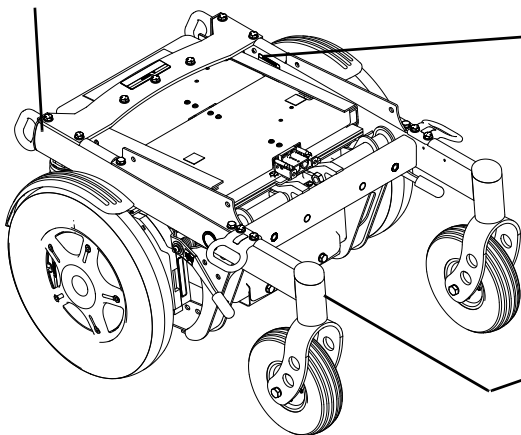

Warning label also found on side frame near the front of the wheelchair.

NO WHEELCHAIR HAS BEEN APPROVED FOR USE AS A SEATING SURFACE WITHIN A MOTOR VEHICLE. THIS LABEL IS FOR INFORMATIONAL PURPOSES ONLY. LIABILITY ISSUES WERE NOT CONSIDERED IN THE ATTACHMENT OF THIS LABEL.

AUCUN FAUTEUIL ROULANT N'A ÉTÉ APPROUVÉ POUR ÊTRE UTILISÉ COMME SIÈGE À L'INTÉRIEUR D'UN VÉHICULE MOTORISÉ. CETTE ÉTIQUETTE NE PEUT ÊTRE UTILISÉE QU'À TITRE D'INFORMATION ET N'A PAS ÉTÉ AFFICHÉE ICI POUR DES RAISONS DE RESPONSABILITÉ LÉGALE

Suspension Arm Used with Conventional Motor/ Gearbox Assembly

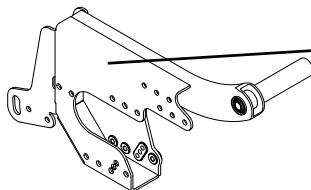

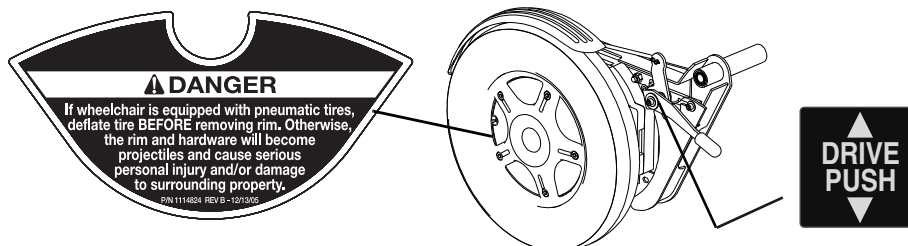

2.2 Wheelchairs with O₂ Holders

ASBA Seats

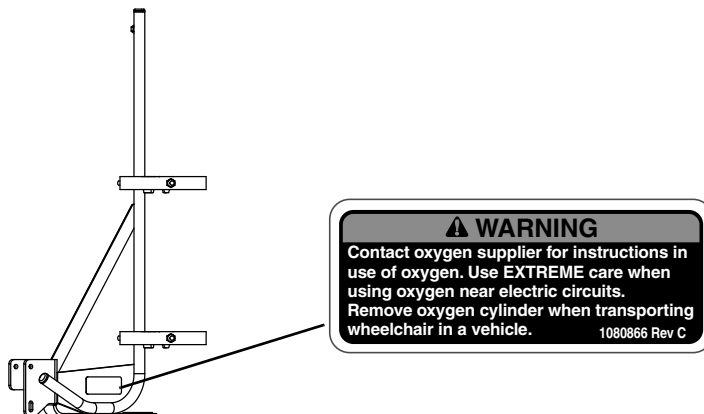

2 LABEL LOCATIONS

2.3 Wheelchairs with TRRO



As of January 1, 2017, TRRO (Transport Ready Option) has been discontinued on this product. Please contact your dealer or Invacare for legacy information or to answer questions regarding TRRO.

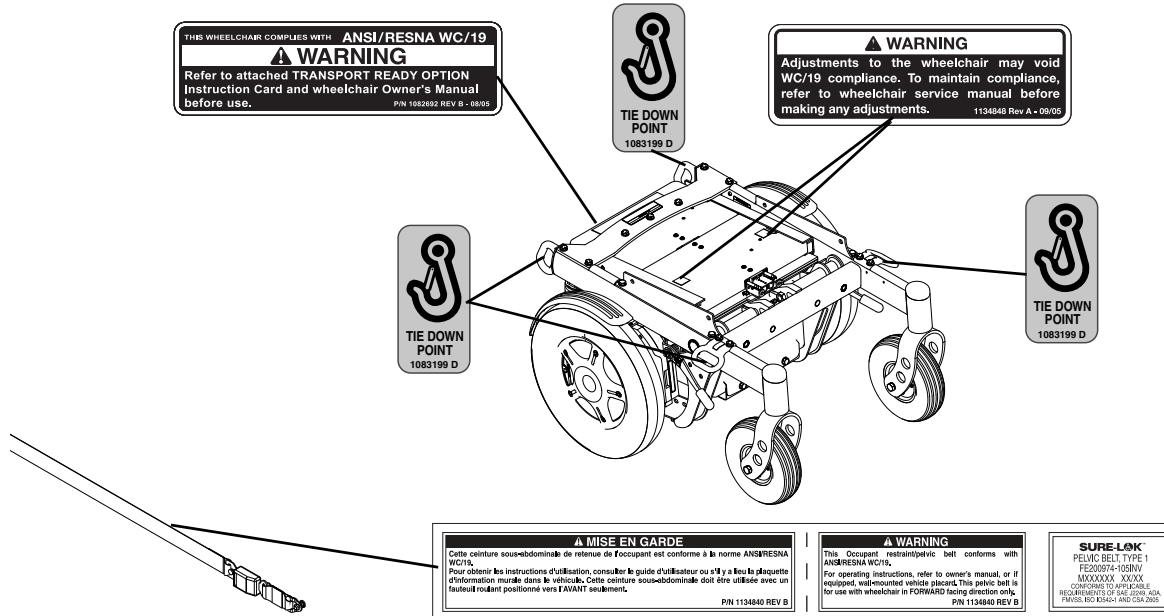

3 Wear and Tear Information

3.1 General Information

Normal wear and tear items and components include but are not limited to: all upholstery items including seat and back upholstery, arm and calf pads, cushions, wheels, tires and casters, all types of batteries, joystick overlays and inductive rubberized protective boots.

Invacare reserves the right to ask for any item back that has an alleged defect in workmanship. Refer to the Warranty section in this manual for specific warranty information.

Refer to the Inspection Checklists in this manual for proper preventative maintenance schedule.

This is just a general guideline and does not include items damaged due to abuse and misuse.

PRODUCT TYPE	PRODUCT WEAR AND TEAR
Wheelchairs	Wheels, Brake Assembly, Hand Grips
Scooters	Wheels, Braking System, Armrest, Seat
Mobility Hardware and Electronics	Rubber Urethane Tires and Casters, Handgrips, Joystick Inductive Tops, Joystick Overlays, Motors and Gearboxes (if exposed to prolonged moisture, urine, etc.), Stability Lock
Upholstery and Seating	Arm Pads, Seat Cushion Foam, Seat Cushion Covers, Back Cushion Foam, Back Cushion Covers, Headrest Foam, Headrest Covers, Footplate Covers, Calf Pad (if applicable) Foam and Cover
Batteries	Lead acid/Lithium, Coin cell (watch type), Gel (6 months)

4 Safety

The safety section contains important information for the safe operation and use of this product.

4.1 General Guidelines



DANGER

Risk of Injury, Damage or Death

Improper use of this product may cause injury or damage.

If you are unable to understand the warnings, cautions or instructions, contact a health care professional or dealer before attempting to use this equipment.

—DO NOT use this product or any available optional equipment without first completely reading and understanding these instructions and any additional instructional material such as user manual, service manuals or instruction sheets supplied with this product or optional equipment.

Continued use of the wheelchair with damaged parts could lead to the wheelchair malfunctioning, causing injury to the user and/or caregiver.

—Check all wheelchair components and carton for damage and test components before use. In case of damage or if the wheelchair is not working properly, contact a qualified technician or Invacare for repair.



WARNING

Risk of Serious Injury or Damage

Use of non-Invacare accessories may result in serious injury or damage.

—Invacare products are specifically designed and manufactured for use in conjunction with Invacare accessories.

Accessories designed by other manufacturers have not been tested by Invacare and are not recommended for use with Invacare products.

—DO NOT use non-Invacare accessories.

To obtain Invacare accessories, contact Invacare by phone or at www.invacare.com.

**DANGER****Risk of Death, Serious Injury or Damage**

Use of incorrect or improper replacement (service) parts may cause death, serious injury, or damage.

- Replacement parts **MUST** match original Invacare parts.
- ALWAYS** provide the wheelchair serial number to assist in ordering the correct replacement parts.

**DANGER****Risk of Death or Serious Injury**

Not wearing your seat positioning strap could result in death or serious injury.

- ALWAYS** wear your seat positioning strap. Your seat positioning strap helps reduce the possibility of a fall from the wheelchair. The seat positioning strap is a positioning belt only. It is not designed for use as a safety device withstanding high stress loads such as auto or aircraft safety belts. If signs of wear appear, seat positioning strap **MUST** be replaced **IMMEDIATELY**.

**WARNING****Risk of Injury, Damage or Death**

Use of the wheelchair while judgement or ability is impaired may result in injury, damage or death.

- DO NOT** operate the wheelchair under the influence of alcohol, medications or other substances that impair judgement or function.
- Changing medications may affect your ability to operate the wheelchair. Discuss the impact on your ability to operate the wheelchair with a health care professional when changing medications.
- DO NOT** operate the wheelchair under conditions where judgement or function may be impaired. This may include but is not limited to lack of sleep or poor sight.
- Always be aware of your surroundings.



DANGER

Risk of Injury, Damage or Death

Exposure to liquids may cause injury, damage or death.

- DO NOT expose electrical connections to sources of liquid or dampness. This includes, but is not limited to, water, body fluids or cleaning agents.
- DO NOT expose battery charger or other accessories to sources of liquid or dampness.
- Wheelchairs that are used by incontinent users and/or are frequently exposed to water/liquids may require replacement and inspection of electrical components more frequently than normal schedule dictates.
- Electrical components damaged by corrosion **MUST** be replaced immediately.



CAUTION

Risk of Damage

Operating the wheelchair in rain or dampness may cause the wheelchair to malfunction electrically and mechanically; may cause the wheelchair to prematurely rust or may damage the upholstery.

DO NOT leave wheelchair in a rain storm of any kind.

DO NOT use wheelchair in a shower.

DO NOT leave wheelchair in a damp area for any length of time.

Check to ensure that the battery covers are secured in place, joystick boot is **NOT** torn or cracked where water can enter and that all electrical connections are secure at all times. **DO NOT** use if the joystick boot is torn or cracked. If the joystick boot becomes torn or cracked, replace **IMMEDIATELY**.



Invacare has tested its wheelchairs in accordance with RESNA WC— 2:2009, Section 9 Part 7.3 “Rain Test”. This provides the end user or his/her attendant sufficient time to remove his/her wheelchair from a rain storm and retain wheelchair operation.

**DANGER****Risk of Death, Serious Injury or Damage**

Alteration or substitution may result in injury, damage or death.

—DO NOT alter or substitute product parts, components or systems.

**DANGER****Risk of Injury or Damage**

Improper lifting technique may cause injury or damage.

—Use proper lifting techniques, assistance and gear such as straps when available when lifting heavy loads.

**WARNING****Risk of Injury or Damage.**

To avoid injury or damage from moving parts:

—ALWAYS keep hands and fingers clear of moving parts.

—Closely supervise children, pets, or people with physical/mental disabilities.

**WARNING****Risk of Injury, Damage or Death**

Damaged parts due to collision or impact may result in injury, damage or death.

—Seek immediate attention and service if wheelchair is involved in a collision or impact event. This includes, but is not limited to, vehicle accidents, mishandling and impact events where the wheelchair strikes something or is struck by something that may cause damage.

—Ensure your wheelchair is working properly and is inspected by a qualified invacare technician if the wheelchair is involved in a collision or impact event.



WARNING

Risk of Injury, Damage or Death

Improper routing of cord(s) may cause a tripping, entanglement or strangulation hazard that may result in injury, damage or death.

- Ensure all cord(s) are routed and secured properly.
- Ensure there are no loops of excess cable extending away from the chair.
- Close supervision and attention is needed when operating the wheelchair near children, pets or people with physical/ mental disabilities.



WARNING

Risk of Injury, Damage or Death

Pinched or severed cord(s) may be a shock or fire hazard and may cause injury, damage or death.

- Ensure all cord(s) are routed and secured properly.
- Inspect cord(s) periodically for proper routing, pinching, chafing or other similar wear.
- Replace any damaged cords immediately.



WARNING

Risk of Injury, Damage or Death

Conditions such as restlessness, mental deterioration, dementia, seizure disorders (uncontrolled body movement) or sleeping problems may cause injury, damage or death.

- Monitor patients with these conditions frequently.
- Close supervision and attention is needed when operating the wheelchair near children, pets or people with physical/ mental disabilities.

**WARNING****Risk of Injury, Damage or Death**

Improper monitoring or maintenance may cause injury, damage or death due to ingestion or choking on parts or materials.
—Closely supervise children, pets, or people with physical/mental disabilities.

**WARNING****Risk of Injury or Damage.**

Unintended movement or operation of wheelchair may cause injury or damage.

- Turn power OFF BEFORE entering or exiting the wheelchair.
- Close supervision and attention is needed when operating the wheelchair near children, pets or people with physical/mental disabilities.
- Turn power off when near children, pets or people with physical/mental disabilities



DANGER

Risk of Death, Serious Injury or Damage

Missing attaching hardware could cause instability resulting in death, serious injury or damage. Ensure all attaching hardware is present and tightened securely.

Risk of Death, Serious Injury or Damage

Lighted cigarettes dropped onto an upholstered seating system can cause a fire resulting in death, serious injury, or damage. Wheelchair occupants are at particular risk of death or serious injury from these fires and resulting fumes because they may not have the ability to move away from the wheelchair.
DO NOT smoke while using this wheelchair.

Risk of Death or Serious Injury

Electric shock can cause death or serious injury.

To avoid electric shock, inspect plug and cord for cuts and/or frayed wires. Replace cut cords or frayed wires immediately.



WARNING

Risk of Serious Injury or Damage

Attaching hardware that is loosely secured could cause loss of stability resulting in serious injury or damage
After ANY adjustments, repair or service and before use, make sure that all attaching hardware is tightened securely.

Risk of Serious Injury or Damage

Loss of power due to loose electrical connections could cause the wheelchair to suddenly stop resulting in serious injury or damage.

ALWAYS ensure that all electrical connections are tightly connected so they do not vibrate loose.

Risk of Minor to Serious Injury

Pinch points can cause minor to serious injury.

Be mindful of potential pinch points and use caution when using this product.

Risk of Serious Injury

Impacting objects in the surrounding environment can cause serious injury.

When maneuvering the wheelchair around, ALWAYS have assured cleared distance with all objects in environment.

Risk of Serious Injury

Sharp edges can cause serious injury.

Be mindful that some parts may have sharp edges. Use caution when encountering these sharp edges.

4 SAFETY



WARNING

Risk of Serious Injury

Hot surfaces can cause severe burns.

Be mindful of potential hot surfaces and avoid touching.



WARNING

Risk of Serious Injury or Damage

Dropping the battery can result in serious injury or property damage.

Batteries can weigh up to 52 lbs (23.6 kg). ALWAYS use a battery lifting strap when lifting the battery. It is the most reliable method of carrying a battery and preventing serious injury.



WARNING

Risk of injury or damage

Improper mounting or maintenance of the Sip n' Puff control including the mouthpiece and breath tube may cause injury or damage.

Water inside the Sip n' Puff interface module may cause damage to the unit.

Excessive saliva residue in the mouthpiece/straw can reduce performance.

Blockages, a clogged saliva trap or air leaks in the system may cause Sip n' Puff not to function properly.

Ensure moving parts of the wheelchair, including the operation of powered seating, DO NOT pinch or damage the Sip n' Puff tubing.

Saliva trap MUST be installed to reduce risk of water or saliva entering the Sip n' Puff interface module.

Occasionally flush the mouthpiece to remove saliva residue.

The mouthpiece/straw MUST be completely dry before installation.

If Sip n' Puff does not to function properly, inspect system for blockages, clogged saliva trap or air leaks.

As necessary, replace mouthpiece, breath tube and saliva trap.



Contact your Invacare dealer/provider for more information about maintaining and troubleshooting the Sip n' Puff system.



NOTICE

THE INFORMATION CONTAINED IN THIS DOCUMENT IS SUBJECT TO CHANGE WITHOUT NOTICE.

As a manufacturer of wheelchairs, Invacare endeavors to supply a wide variety of wheelchairs to meet many needs of the end user. However, final selection of the type of wheelchair to be used by an individual rests solely with the user and his/her healthcare professional capable of making such a selection. Invacare recommends working with a qualified rehab technology provider, such as an ATP, (Assistive Technology Professional).

4.2 Setup Guidelines



WARNING

Risk of Injury, Damage or Death

Improper setup, service, adjustment or programming may cause injury, damage or death.

- Qualified technician **MUST** setup, service and program the wheelchair.
- DO NOT** allow non-qualified individuals to perform any work or adjustments on the wheelchair.
- DO NOT** setup or service the wheelchair while occupied except for programming or unless otherwise noted.
- Turn off power **BEFORE** adjusting or servicing the wheelchair. Note that some safety features will be disabled.
- Ensure all hardware is securely tightened after setup, service or adjustments.



DANGER

Risk of Death, Serious Injury, or Damage

Continued use of the wheelchair that is not set to the correct specifications may cause erratic behavior of the wheelchair resulting in death, serious injury, or damage.

- Performance adjustments should only be made by professionals of the healthcare field or persons fully conversant with this process and the driver's capabilities.
- After the wheelchair has been set up/adjusted, check to make sure that the wheelchair performs to the specifications entered during the set up procedure. If the wheelchair does not perform to specifications, turn the wheelchair Off immediately and reenter set up specifications. Contact Invacare, if wheelchair still does not perform to correct specifications.



WARNING

Risk of Serious Injury or Damage

Moving the seating system from the factory setting may reduce driver control, wheelchair stability, traction and increase caster wear resulting in serious injury or damage.

- Move the seating system **ONLY** when necessary to fit the wheelchair to the user.
- If the seating system must be moved, **ALWAYS** inspect the wheelchair to ensure the front rigging **DOES NOT** interfere with the front casters.
- If the seating system must be moved, **ALWAYS** inspect to ensure the wheelchair **DOES NOT** easily tip forward or backward.



WARNING

DO NOT connect any medical devices such as ventilators, life support machines, etc. directly to the batteries used to power the wheelchair. This could cause unexpected failure of the device and the wheelchair.

4.3 Operation Guidelines



DANGER

Risk of Death, Serious Injury or Damage

Misuse of wheelchair may result in injury, damage or death.

- DO NOT operate wheelchair on roads, streets or other roadways.
- DO NOT operate wheelchair when vision is impaired by poor lighting such as unlit rooms, during the night or similar situations.
- Always be aware of motor vehicles and your surroundings.
- DO NOT operate the wheelchair under the influence of alcohol, medications or other substances that impair judgement or function.



WARNING

Risk of Serious Injury or Damage

Improper transfer techniques may cause serious injury or damage.

- Before attempting transfers, consult a health care professional to determine proper transfer techniques for the user and type of wheelchair.

4 SAFETY

4.4 Transport Guidelines



WARNING

Risk of Injury, Damage or Death

Improper use on stairways or escalators may cause injury, damage or death.

- DO NOT attempt to move an occupied wheelchair between floors using a stairway or escalator.
- DO NOT attempt to move an empty power wheelchair between floors using an escalator.
- Observe and follow all safety warnings and instructions.
- Use instructions provided for safe transportation between floors.

Follow this procedure for moving the wheelchair between floors when an elevator is NOT available:



When using a stairway to move the wheelchair and any accessories, move all wheelchair components away from the stairway prior to reassembly. Invacare recommends using two assistants and making thorough preparations prior to transportation.

1. Use an elevator or other accepted safe means of transportation between floors.
2. If stairway or escalator is only means of access, remove occupant of wheelchair and transport user and wheelchair separately.
3. Ensure that only secure, non-detachable parts are used for hand-hold supports.
4. Remove the occupant from the wheelchair.
5. Use safe lifting techniques. The weight of the wheelchair without user and without batteries may range between 154–278 lbs.
6. Remove the battery boxes from wheelchair. Refer to [Removing/Installing Battery Boxes](#) on page 95.
7. Using non-removable (non-detachable) parts of the wheelchair, lift the wheelchair off of the ground and transfer the wheelchair up or down the stairs.
8. The wheelchair should not be lowered until the last stair has been negotiated and the wheelchair has been carried away from the stairway.

Repair or Service Information (Dealers and/or Qualified Technicians)



DANGER

Risk of Death, Serious Injury or Damage

Corroded electrical components due to water and/or liquid exposure, or incontinent users can result in death, serious injury, or damage.

- Minimize exposure of electrical components to water and/or liquids. Electrical components damaged by corrosion **MUST** be replaced immediately.
- Wheelchairs that are used by incontinent users and/or are frequently exposed to water/liquids may require replacement of electrical components more frequently.



WARNING

Risk of Injury, Damage or Death

Improper installation or service may result in injury, damage or death.

- DO NOT overtighten hardware.
- Transport ready packages are not retrofittable to existing models and are not field serviceable.

4.5 Safety/Handling

“Safety and Handling” of the wheelchair requires the close attention of the wheelchair user as well as the assistant. This manual points out the most common procedures and techniques involved in the safe operation and maintenance of the wheelchair. It is important to practice and master these safe techniques until you are comfortable in maneuvering around the frequently encountered architectural barriers.

Use this information only as a “basic” guide. The techniques that are discussed on the following pages have been used successfully by many.

Individual wheelchair users often develop skills to deal with daily living activities that may differ from those described in this manual. Invacare recognizes and encourages each individual to try what works best for him/her in overcoming architectural obstacles that they may encounter. However all warnings and cautions given in this manual **MUST** be followed. Techniques in this manual are a starting point for the new wheelchair user and assistant with “safety” as the most important consideration for all.

Invacare strongly recommends that initial use of rear wheel drive wheelchairs be supervised by an assistant.



WARNING

Risk of Injury, Damage or Death

Loss of traction or stability on inclines/grades or ramps may cause injury, damage or death. Lighter weight users may be at an increased risk. Surfaces that may be wet, icy, oily, slippery, painted, treated wood, rotten wood, rusted metal or other similar surfaces or materials may also increase risk.

- DO NOT use on inclines or ramps where surface is uncertain or compromised.
- DO NOT use on inclines greater than nine (9) degrees.
- DO NOT operate the seating system while the wheelchair is moving. Stop before operating seating system.
- DO NOT operate the seating system while on an incline. Operation on an incline may result in increased instability.
- To determine and establish your particular safety limits, practice use of this product on various sloping surfaces in the presence of a qualified healthcare provider before attempting active use of this wheelchair.
- DO NOT use on inclines where line of sight is impaired.
- Travel at a reduced, constant speed and DO NOT make sudden stops or direction changes. Release the joystick and allow the wheelchair to come to a full stop before changing directions. Traveling at high speeds reduces traction and increases stopping distance.
- DO NOT drive in an elevated position while on an incline.
- DO NOT leave elevating legrests in the fully extended position when proceeding down inclines/grades.
- DO NOT leave an unoccupied wheelchair unattended on inclines or ramps.

**WARNING****Risk of Injury, Damage or Death**

Traveling down inclines in reverse could cause the wheelchair to tip over resulting in death or serious injury.

—DO NOT travel down inclines in reverse.

**WARNING****Risk of Injury, Damage or Death**

Malfunctioning or damaged joystick may cause unintended/erratic movement resulting in injury, damage or death.

—Ensure the joystick is securely connected to controller.

—DO NOT use if joystick does not spring back to the neutral position or becomes sticky or sluggish.

—DO NOT use if joystick boot is torn or damaged.

—DO NOT use with a broken or missing control knob.

—If unintended/erratic movement occurs, stop using the wheelchair immediately and contact a qualified technician.

—Ensure control knobs are secure before using the wheelchair. Stop using the wheelchair immediately and contact a qualified technician if control knobs are not secure.

4 SAFETY



WARNING

Risk of Injury, Damage or Death

Loss of traction or stability may cause injury, damage or death.

- DO NOT operate the wheelchair without anti-tippers installed. Anti-Tippers must be used at all times.
- Avoid crossing soft surfaces such as wet or soft ground, gravel or mulch. Anti-tippers may not provide the same level of stability.
- Wheelchairs equipped with ventilator tray **MUST** have extended active anti-tippers installed.
- Wheelchairs that are **NOT** equipped with optional ventilator tray **MUST** have either the standard anti-tippers or the optional extended active anti-tippers installed.



DANGER

Risk of Injury or Damage

Misuse of wheel locks may result in injury or damage.

- DO NOT attempt to stop a moving wheelchair with the wheel locks. Wheel locks are not brakes.
- DO NOT use the wheel locks (if equipped) when the wheelchair power is on. Invacare recommends the use of wheel locks.



DANGER

Risk of Death, Serious Injury or Damage

Misuse of the wheelchair may cause component failure and/or the wheelchair to start smoking, sparking, or burning. Death, serious injury, or damage may occur due to fire.

- DO NOT use the wheelchair other than its intended purpose. If the wheelchair starts smoking, sparking, or burning, discontinue using the wheelchair and seek service **IMMEDIATELY**.

**DANGER****Risk of Serious Injury or Damage**

Improperly connecting the motor leads to the controller may cause injury or damage.

WHEELCHAIRS WITH G-TRAC: Crossing the motor leads (for example: connecting the left motor lead into the right motor connector on the controller) may result in unintended movement.

DO NOT cross the motor leads when connecting the motors to the controller—otherwise injury or damage may occur.

**WARNING****Risk of Injury, Damage or Death**

Improper operation may change the normal balance, center of gravity or weight distribution of the wheelchair and may cause injury or damage.

- Determine and establish your particular safety limits. Practice bending, reaching and transferring activities in several combinations in the presence of a qualified healthcare professional before attempting active use of the wheelchair.
- ALWAYS shift your weight in the direction you are turning. Shifting your weight in the opposite direction of the turn may cause the inside drive wheel to lose traction.

A Note to Wheelchair Assistants

When assistance to the wheelchair user is required, remember to use good body mechanics. Keep your back straight and bend your knees whenever tilting wheelchair or traversing curbs or other impediments.

Also, be aware of detachable parts such as arms or legrests. These must NEVER be used to move the wheelchair or as lifting supports, as they may be inadvertently released, resulting in possible injury to the user and/or assistant(s).

When learning a new assistance technique, have an experienced assistant help you before attempting it alone.

4 SAFETY

Stability and Balance



WARNING

Risk of Injury or Damage

Loss of traction or stability on rough or unstable terrain may cause injury, damage or death.

—DO NOT operate the wheelchair on rough or unstable terrain. This would include but is not limited to areas of rock, mulch, mud, uneven pavement, roots and similar conditions.

—Be aware of your surroundings and conditions that might affect the ability to operate the wheelchair.



WARNING

Risk of Injury, Damage or Death

Improper use of wheelchair may cause instability and may result in injury, damage or death. The stability of the wheelchair is adversely affected by additional weight that shifts the center of gravity.

—This wheelchair has been designed to accommodate one individual. DO NOT operate with additional person(s).

—DO NOT carry heavy objects on your lap while operating the wheelchair.



WARNING

Risk of Injury or Damage

Improper position and activity such as reaching, bending, or transferring may change the normal balance, center of gravity or weight distribution of the wheelchair may cause injury or damage.

- Observe and follow all instructions and warnings regarding reach, weight, balance and positioning.
- Determine and establish your particular safety limits. Practice bending, reaching and transferring activities in several combinations in the presence of a qualified healthcare professional before attempting active use of the wheelchair.
- DO NOT move beyond the center of gravity.
- DO NOT lean forward out of the wheelchair any further than the length of the armrests.
- DO NOT attempt to reach objects if you have to move forward in the seat or pick them up from the floor by reaching down between your knees.
- DO NOT shift your weight or sitting position toward the direction you are reaching.
- DO NOT stand on the frame of the wheelchair.
- DO NOT lean over the top of the back of the wheelchair.

To assure stability and proper operation of your wheelchair, you must at all times maintain proper balance. Your wheelchair has been designed to remain upright and stable during normal daily activities as long as you DO NOT move beyond the center of gravity. DO NOT lean forward out of the wheelchair any further than the length of the armrests.

Changing the position of where the motors are positioned affects the weight distribution over the rear wheels. The following contains information about changing the position of the motors.

Rear Position—Lengthens the wheelbase and gives the wheelchair the most stability and standard maneuverability.

Middle Position—Centers the wheelbase and gives the wheelchair standard stability and maneuverability.

Forward Position—Shortens the wheelbase and increases maneuverability and distributes additional weight on rear wheels.

The following shows the positions of the screws into the gearbox:

DETAIL “A”—MOTOR/GEARBOX WHEELCHAIRS

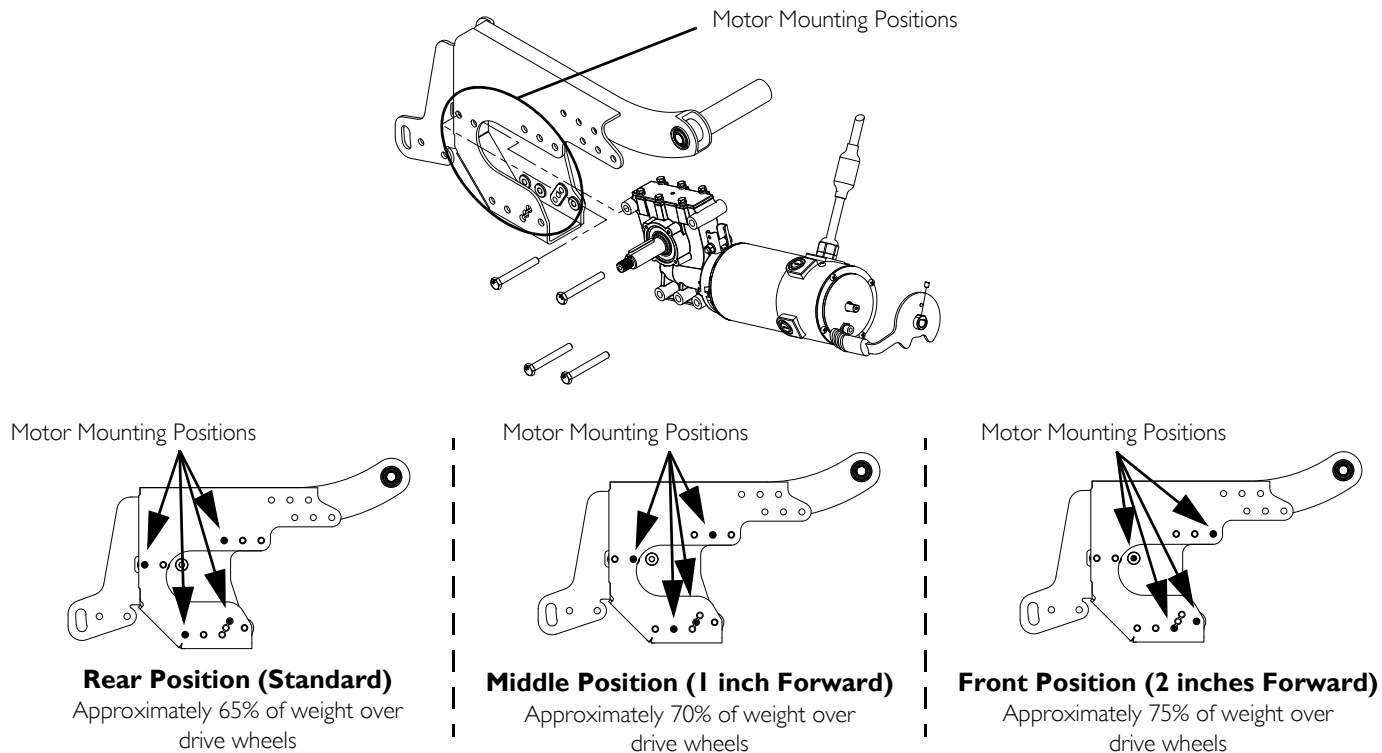

FIGURE 1 Stability and Balance

Coping with Everyday Obstacles

Coping with the irritation of everyday obstacles can be somewhat alleviated by learning how to manage your wheelchair. Keep in mind your center of gravity to maintain stability and balance.



WARNING

Risk of Injury, Damage or Death

Loss of traction or stability on curbs/obstacles may cause injury, damage or death.

- DO NOT cross curbs/obstacles that are not suitable for wheelchairs.
- DO NOT attempt to pass curbs/obstacles that are greater than 60mm (2.36 in).
- Follow all instructions regarding negotiating curbs, obstacles and inclines.
- ALWAYS stop before negotiating an obstacle.
- Approach slowly until caster wheels are approximately 46 cm (18 inches) away from the obstacle.
- Slowly apply power to move forward/reverse while negotiating the obstacle.

While the wheelchair is designed for use primarily in and around the home, the provider should determine whether this wheelchair is suitable for the actual environment in which the wheelchair will be used.

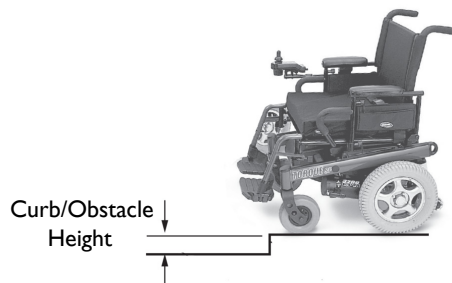

4 SAFETY

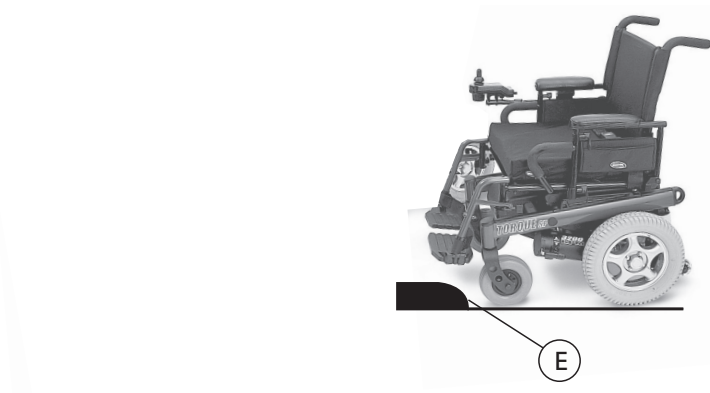

*Improved performance can be achieved when climbing over rolled curbs (E).

DO NOT go down a ramp at full speed. Some seat/back positions will cause the wheelchair to feel unstable.

Footplates and Front Rigging



WARNING

Risk of Serious Injury or Damage

Operating the wheelchair with a ground clearance of less than 75mm/three (3) inches between the footplates and the ground/floor may cause serious injury or property damage.

—ALWAYS maintain a minimum of 75mm/three (3) inches between the bottom of the footplates and ground/floor to ensure proper ground clearance while the wheelchair is in motion. If necessary, adjust the footplates height to achieve proper ground clearance. After footplates height adjustment, if the wheelchair dips forward and the footplates touch the ground while in motion, please contact your dealer for an inspection and avoid use of the wheelchair if possible.

**WARNING****Risk of Injury or Damage**

Misuse of footplate may cause injury or damage.

—DO NOT stand on footplates.

—Ensure the footplates are in the upward position or swung outwards when getting in or out of the wheelchair.

**CAUTION****Risk of Damage**

Improper setup of footrests may cause damage.

—Ensure the rear of the footrests DO NOT interfere with the movement of the front casters when performing setup, service or maintenance.

4 SAFETY

Reaching, Leaning and Bending—Forward

i For this procedure, refer to FIGURE 2.

Engage motor lock levers or wheel locks (if equipped) and turn power off before reaching, leaning or bending only as far as your arm will extend without changing your sitting position.

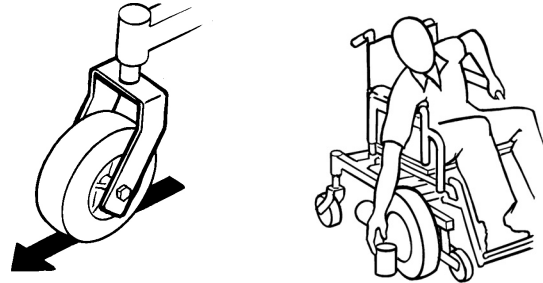

FIGURE 2 Reaching, Leaning and Bending—Forward

Reaching, Leaning and Bending—Backward

i For this procedure, refer to FIGURE 3.

Position wheelchair as close as possible to the desired object. Position the casters so that they are extended away from the drive wheels to create the longest possible wheelbase, engage the motor lock levers and turn power off. Reach back only as far as your arm will extend without changing your sitting position.



FIGURE 3 Reaching, Leaning and Bending—Backward

Transferring To and From Other Surfaces



WARNING

Risk of Serious Injury or Damage

Improper transfer techniques may cause serious injury or damage.

—Before attempting transfers, consult a health care professional to determine proper transfer techniques for the user and type of wheelchair.



For this procedure, refer to FIGURE 4.

Adequate mobility and upper body strength is required to perform this activity independently.

1. Transfer to and from the wheelchair in the presence of a qualified healthcare professional to determine individual safety limits.
2. Turn power button OFF BEFORE entering or exiting the wheelchair.
3. Reduce gap between transfer surface and wheelchair seat to the minimum distance necessary to perform transfer.
4. ALWAYS engage both motor lock levers (if equipped) to prevent the wheels from moving before transferring into or from the wheelchair.
5. Align casters parallel to the drive wheels to improve stability during transfer.
6. Invacare strongly recommends ordering wheel locks as an additional safeguard if not present.
7. Engage motor lock levers. Refer to [Disengaging/Engaging Motor Lock Levers](#) on page 69.

8. Shift body weight into seat with transfer.



During independent transfer, little or no seat platform will be beneath you. Use a transfer board if at all possible.

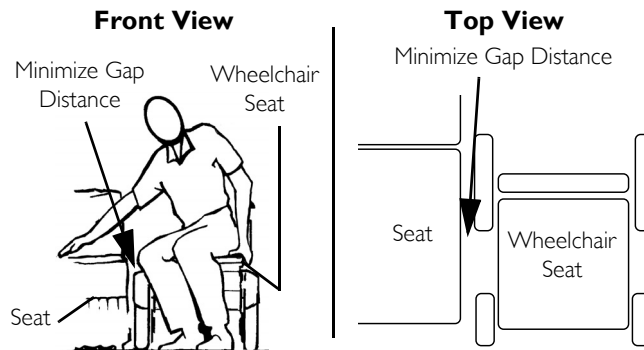

FIGURE 4 Transferring To and From Other Surfaces

4 SAFETY

Storage



WARNING

Risk of Injury, Damage or Death

Storage or use near heat sources and combustible products may result in injury or damage.

- DO NOT store or use wheelchair near open flames or other heat sources.
- DO NOT store or use wheelchair near combustible products.

Electrical—Grounding Instructions



DANGER

Risk of Death, Injury or Damage

Shock hazards and risk of fire exist due to use of improper extension cord and/or use of three prong adapters.

- To avoid injury or product damage, when using an extension cord, use only a UL approved three wire extension cord having at least 16 AWG (American Wire Gauge) wire and the same or higher electrical rating as the device being connected.
- DO NOT use three prong to two prong adapters.

Batteries



Failure to use the correct battery size and/or voltage may cause damage to your wheelchair and give you unsatisfactory performance. The warranty and performance specifications contained in this manual are based on the use of deep cycle gel cell batteries. Invacare strongly recommends their use as the power source for this unit.

Charging Batteries



Invacare does not recommend using an extension cord. Use an extension cord only when necessary. Plug battery charger directly into wall outlet when possible.



DANGER

When using an extension cord, use an extension cord having at least 16 AWG (American Wire Gauge) wire and the same or higher electrical rating as the device being connected. Use of improper extension cord could result in a risk of fire and electric shock.



WARNING

Risk of Injury, Damage or Death

Improper charging may cause injury or damage.

- Charge battery in a cool, dry and well-ventilated area.
- DO NOT attempt to recharge the batteries by attaching cables directly to the battery terminals.
- DO NOT attempt to recharge the batteries and operate the wheelchair at the same time.
- DO NOT attempt to recharge the batteries when the wheelchair has been exposed to any type of moisture.
- DO NOT sit in the wheelchair while charging the batteries.
- READ and CAREFULLY follow the manufacturer's instructions for each charger (supplied or purchased). If charging instructions are not supplied, consult a qualified technician for proper procedures.
- Ensure the pins of the extension cord plug are the same number, size, and shape as those on the charger.
- DO NOT leave the charger unattended when the breaker has tripped. Unplug and discontinue use immediately. Contact a qualified service technician or Invacare for service.

4 SAFETY

Tire Pressure



DANGER

Risk of Injury, Damage or Death

Overinflation of tires may cause tires to explode.

—Inflate tire to the proper tire pressure (P.S.I./ kilopascals) listed on the side wall of the tire.

—Only use wheelchair with tires at proper tire pressure.

—The wheels and tires should be checked periodically for cracks and wear and should be replaced if necessary.

Weight Training



WARNING

Risk of Injury, Damage or Death

Invacare DOES NOT recommend the use of its wheelchairs as a weight training apparatus. Invacare wheelchairs have NOT been designed or tested as a seat for any kind of weight training. Using said wheelchair for weight training could result in serious bodily injury to the user, damage to the wheelchair and surrounding property. Also, if occupant uses said wheelchair as a weight training apparatus, Invacare shall NOT be liable for bodily injury and the warranty is void.

—DO NOT use the wheelchair as a weight training apparatus.

Shipping Securement Points



WARNING

Risk of Injury or Damage

Misuse may cause injury or damage.

—Frame end caps are only for manufacturer's initial shipping securement points. **DO NOT** use for any other intent.

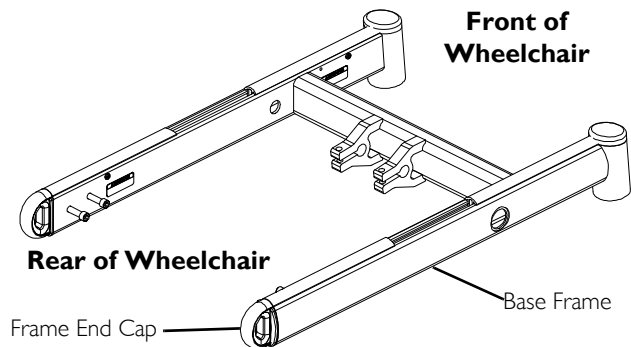

5 Electromagnetic Compatibility (EMC) Information

5.1 Electromagnetic Interference (EMI) From Radio Wave Sources

Powered wheelchairs and motorized scooters (in this text, both will be referred to as powered wheelchairs) may be susceptible to electromagnetic interference (EMI), which is interfering electromagnetic energy (EM) emitted from sources such as radio stations, TV stations, amateur radio (HAM) transmitters, two way radios, and cellular phones. The interference (from radio wave sources) can cause the powered wheelchair to release its brakes, move by itself, or move in unintended directions. It can also permanently damage the powered wheelchair's control system. The intensity of the interfering EM energy can be measured in volts per meter (V/m). Each powered wheelchair can resist EMI up to a certain intensity. This is called its "immunity level." The higher the immunity level, the greater the protection. At this time, current technology is capable of achieving at least a 20 V/m immunity level, which would provide useful protection from the more common sources of radiated EMI.

There are a number of sources of relatively intense electromagnetic fields in the everyday environment. Some of these sources are obvious and easy to avoid. Others are not apparent and exposure is unavoidable. However, we believe that by following the warnings listed below, your risk to EMI will be minimized.

The sources of radiated EMI can be broadly classified into three types:

1. Hand-held Portable transceivers (transmitters-receivers with the antenna mounted directly on the transmitting unit. Examples include: citizens band (CB) radios, "walkie talkie", security, fire and police transceivers, cellular telephones, and other personal communication devices).



Some cellular telephones and similar devices transmit signals while they are ON, even when not being used.

2. Medium-range mobile transceivers, such as those used in police cars, fire trucks, ambulances and taxis. These usually have the antenna mounted on the outside of the vehicle; and
3. Long-range transmitters and transceivers, such as commercial broadcast transmitters (radio and TV broadcast antenna towers) and amateur (HAM) radios.



Other types of hand-held devices, such as cordless phones, laptop computers, AM/FM radios, TV sets, CD players, cassette players, and small appliances, such as electric shavers and hair dryers, so far as we know, are not likely to cause EMI problems to your powered wheelchair.

5.2 Electromagnetic Interference (EMI)

Because EM energy rapidly becomes more intense as one moves closer to the transmitting antenna (source), the EM fields from hand-held radio wave sources (transceivers) are of special concern. It is possible to unintentionally bring high levels of EM energy very close to the powered wheelchair's control system while using these devices. This can affect powered wheelchair movement and braking. Therefore, the warnings listed below are recommended to prevent possible interference with the control system of the powered wheelchair.

Electromagnetic interference (EMI) from sources such as radio and TV stations, amateur radio (HAM) transmitters, two-way radios, and cellular phones can affect powered wheelchairs and motorized scooters.

FOLLOWING THE WARNINGS LISTED BELOW SHOULD REDUCE THE CHANCE OF UNINTENDED BRAKE RELEASE OR POWERED WHEELCHAIR MOVEMENT WHICH COULD RESULT IN SERIOUS INJURY.



WARNING

- 1) DO NOT operate hand-held transceivers (transmitters receivers), such as citizens band (CB) radios, or turn ON personal communication devices, such as cellular phones, while the powered wheelchair is turned ON;
- 2) Be aware of nearby transmitters, such as radio or TV stations, and try to avoid coming close to them;
- 3) If unintended movement or brake release occurs, turn the powered wheelchair OFF as soon as it is safe;
- 4) Be aware that adding accessories or components, or modifying the powered wheelchair, may make it more susceptible to EMI (NOTE: There is no easy way to evaluate their effect on the overall immunity of the powered wheelchair); and
- 5) Report all incidents of unintended movement or brake release to the powered wheelchair manufacturer, and note whether there is a source of EMI nearby.

Important Information

- 1) 20 volts per meter (V/m) is a generally achievable and useful immunity level against EMI (as of May 1994) (the higher the level, the greater the protection);
- 2) This device has been tested to a radiated immunity level of 20 volts per meter.
- 3) The immunity level of the product is unknown.

Modification of any kind to the electronics of this wheelchair as manufactured by Invacare may adversely affect the EMI immunity levels.

5 ELECTROMAGNETIC COMPATABILITY (EMC) INFORMATION

5.3 Electromagnetic Emission



CAUTION

Risk of Injury or Damage.

EMC interference affecting other products may result in injury or damage.

To avoid impacting the operation and function of other products:

—Products not specified by Invacare that may be used on or near the wheelchair may be impacted by emissions from this product if they have a sensitivity level that is lower than the recognized standard and provided by this wheelchair. Refer to the manufacturer specifications for any electronic device **BEFORE** use near this product to determine its level of immunity and potential risk.

6 Technical Data

6.1 Specifications



All dimensions are $\pm .50$ inches unless otherwise indicated.

Models

Torque SP	3GTQSPBASE, 3GTQSP, 3GTQ-CG, 3GTQ-MCG, 3GTQ3-MCG
Torque 3	3GTQ3, 3GTQ3V, 3GTQ3-CG, 3GTQ3-MCG

Overall Dimensions

	TORQUE SP	TORQUE 3
Base Width (Without Joystick):	25 inches	25 inches
Base Length (Without Front Rigging):		
Standard:	29.5 inches	29.5 inches
Long Frame:	32.5 inches	32.5 inches
Height		
Standard:	34.25 inches	34.25 inches
Minimum:	34.25 inches	34.25 inches
Maximum:	44.25 inches	44.25 inches

6 TECHNICAL DATA

Seat

	TORQUE SP	TORQUE 3
Seat Angle:	Adjustable - 0° to 10°	Adjustable - 0° to 10°
Seat-to-Floor Height Standard		
Low:	17.25 inches (0° Seat Tilt), 17.75 inches (5° Seat Tilt)	17.25 inches (0° Seat Tilt), 17.75 inches (5° Seat Tilt)
Medium:	19.5 inches (0° Seat Tilt), 20 inches (5° Seat Tilt)	19.5 inches (0° Seat Tilt), 20 inches (5° Seat Tilt)
High:	20.25 inches (0° Seat Tilt), 21.25 inches (5° Seat Tilt)	20.25 inches (0° Seat Tilt), 21.25 inches (5° Seat Tilt)

Wheels

	TORQUE SP	TORQUE 3
Casters with Precision Sealed Bearings Semi-Pneumatic		
Standard:	8 x 1.25 inch	8 x 1.25 inch
Optional (with shock fork):	6 x 2 inch	6 x 2 inch
Pneumatic or Foam Filled:		
Standard:	8 x 2 inches	8 x 2 inches
Optional:	9 x 2.75 inch	9 x 2.75 inch
Caster Forks	Standard, Shock Fork (optional)	
Drive Wheel (Foam Filled or Pneumatic):		
Standard:	14 x 3 inch	14 x 3 inch
Optional (Not available with GB Motors):	14 x 4 inch	14 x 4 inch
Drive Axle:	Adjustable (Non-recliners Only)	
Anti-Tipper:	3 inch wheels	3 inch wheels

Batteries

	TORQUE SP	TORQUE 3
Battery Requirements:	Group 24	

Driving

	TORQUE SP	TORQUE 3
Motor Type:	18:1 Ratio 4 Pole Motor	24:1 Ratio 4 Pole Motor
Rating:	300 lbs	
Speed:	Up to 6.5 mph	Up to 5.8 mph
**Range:	Up to 19 miles	



*Force to operate motor lock lever exceeds ANSI/RESNA WC/VOL2-2009 requirements for section I4.7 paragraph 7.2d.

**Values for range are calculated for maximum chair weight rating using largest batteries applicable (GP24), per test procedures described in ANSI/RESNA WC/VOL2-2009 Section 4 and meet federal reimbursement requirements for this product. While considered typical, they are derived based on certain ideal conditions. Variances in battery condition, user weight, usage pattern or overall terrain conditions will result in actual values for range that differ from these stated values. Users should become accustomed to how their unique conditions impact their individual results. Users should become familiar with the battery discharge indicator on the joystick to determine the range of their wheelchair. Refer to When to Charge Batteries on page 65 for more information about the battery discharge indicator.

6 TECHNICAL DATA

Weight

	TORQUE SP	TORQUE 3
Base Weight with rehab seat		
Without Batteries:	154 lbs	154 lbs
With GP24 Batteries:	258 lbs	258 lbs
Shipping Weight:	194 lbs	194 lbs
Maximum Weight Limitation:	300 lbs	300 lbs



Weight limitation is total weight (user weight plus any additional items that the user may require [back pack, etc.]). Example: If weight limitation of the wheelchair is 300 lbs and additional items equal 25 lbs, subtract 25 lbs from 300 lbs this means the maximum weight limitation of the user is 275 lbs.



WARNING

Risk of Death, Serious Injury or Damage

Exceeding the weight capacity of the wheelchair/seating system could cause instability resulting in death or serious injury. DO NOT exceed the weight capacity.

Operating/Storage Temperature

Operating Temperature	122 F (50 C) Maximum to -13 F (-25 C) Minimum
Storage Temperature	149 F (65 C) Maximum to -58 F (-40 C) Minimum

7 Wheelchair Operation

7.1 Operating the Wheelchair

- i** Operating noise may change over time. Sudden or severe change may signal a problem with your wheelchair. Contact a qualified technician or Invacare if issue persists.

Turning the Power On/Off

- i** For this procedure, refer to FIGURE I.

1. To turn the power On, perform one of the following steps:

JOYSTICK	ACTION
CMPJ™ +	Move the On/Off switch Forward to the On position.
SPJ™ +	Press the On/Off button.

2. Turning the power Off can be achieved by performing one of the following steps:

JOYSTICK	ACTION
CMPJ+	Move the On/Off switch Back to the Off position.
SPJ+	Press the On/Off button.

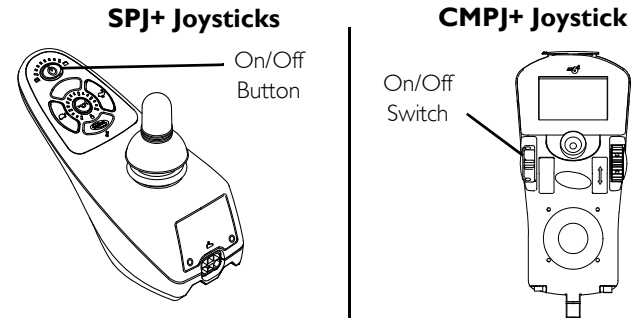

FIGURE I Turning the Power On/Off

7 WHEELCHAIR OPERATION

Using the Joystick to Drive the Wheelchair



WARNING

Risk of Injury, Damage or Death

Malfunctioning or damaged joystick may cause unintended/erratic movement resulting in injury, damage or death.

- Ensure the joystick is securely connected to controller.
- DO NOT use if joystick does not spring back to the neutral position or becomes sticky or sluggish.
- DO NOT use if joystick boot is torn or damaged.
- DO NOT use with a broken or missing control knob.
- Ensure control knobs are secure before using the wheelchair. Stop using the wheelchair immediately and contact a qualified technician if control knobs are not secure.

The joystick is located on the joystick housing and provides smooth control of speed and direction. It is equipped with 360 degrees of mobility for ease of operation. The joystick is spring-loaded, and automatically returns to the upright (neutral) position when released. Pushing the joystick in a given direction causes the wheelchair to move in that direction.

The joystick has proportional drive control, meaning that the further it is pushed from the upright (neutral) position, the faster the wheelchair moves. The maximum speed, however, is limited by the setting of the speed-control knob.

To slow wheelchair to a stop, simply release the joystick. The wheelchair has automatic speed and direction compensation to minimize corrections.

When first learning to drive, select a slow speed and try to drive the wheelchair as slowly as possible by pushing the joystick slightly forward. This exercise will help you learn to utilize the full potential of the proportional control and allow you to start and stop smoothly.

To drive the wheelchair, perform the following:

1. Adjust speed control knob to the appropriate setting.
2. Turn the power On. Refer to [Turning the Power On/Off](#) on page 51.
3. Maneuver the joystick in the following manner:

MOVEMENT	ACTION
FORWARD	Push joystick forward, towards the front of the wheelchair.
REVERSE	Pull joystick back, towards the rear of the wheelchair.
Turn RIGHT	Move joystick toward the right side of the wheelchair.
Turn LEFT	Move joystick toward the left side of the wheelchair.
STOP	Release the joystick and the wheelchair will slow to a stop.

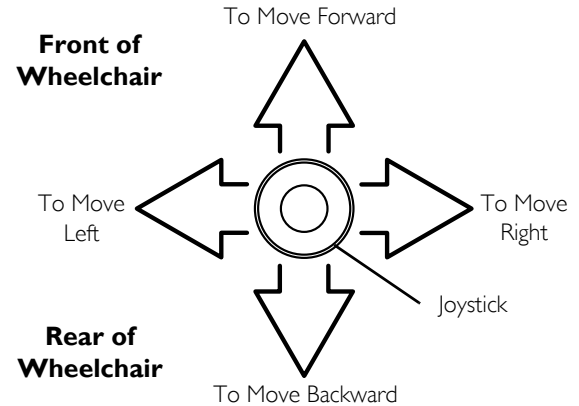

FIGURE 2 Using the Joystick to Drive the Wheelchair



For specific information about the joystick installed on the wheelchair, refer to one of these procedures:

- [SPJ™ +, MK6i™ SPJ+ w/PSS and MK6i SPJ+ w/ACC Joystick Switches and Indicators](#) on page 54.
- [CMPJ+ Joystick Switches and Indicators](#) on page 57.

7 WHEELCHAIR OPERATION

7.2 SPJ™ +, MK6i™ SPJ+ w/PSS and MK6i SPJ+ w/ACC Joystick Switches and Indicators



For this procedure, refer to FIGURE 3.

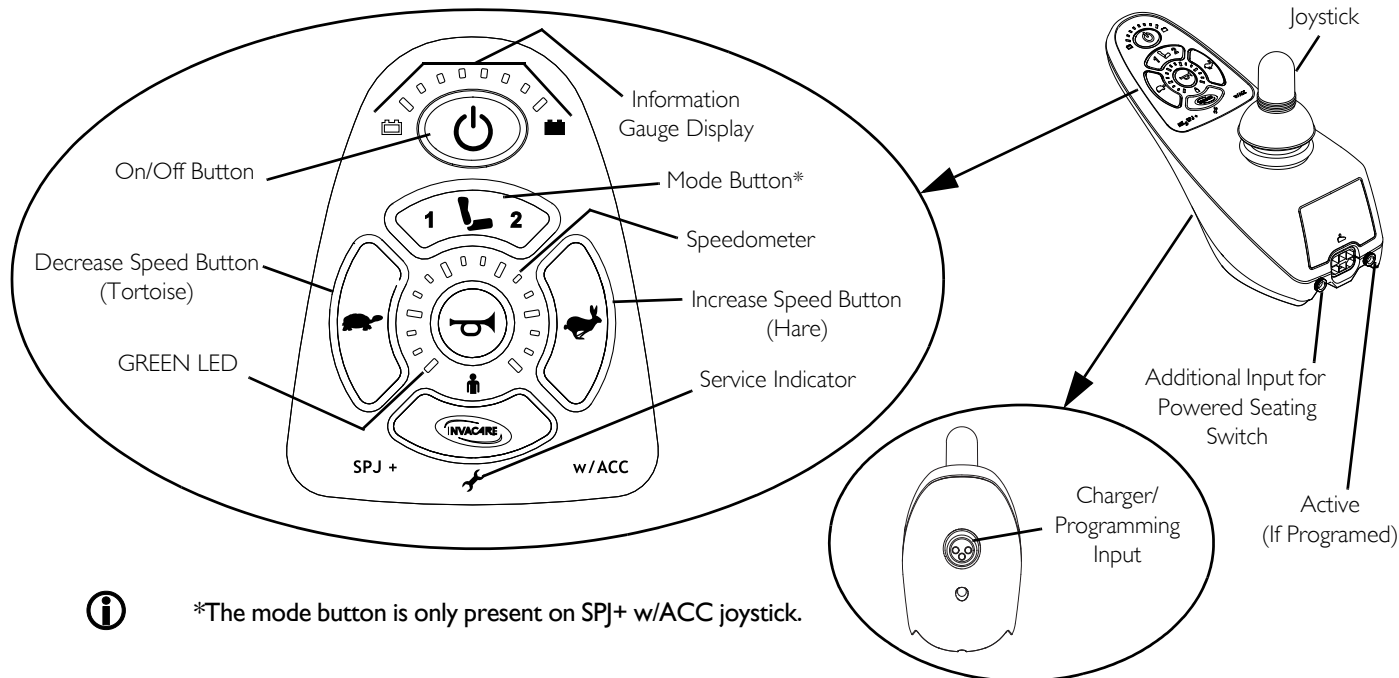

FIGURE 3 SPJ™ +, MK6i™ SPJ+ w/PSS and MK6i SPJ+ w/ACC Joystick Switches and Indicators



On/Off Button

This button is located at the front of the joystick housing. It is used to turn the wheelchair On and Off.









Speedometer

The speedometer is used to show the maximum speed. The right-most LED indicates current maximum speed setting. The bottom left GREEN LED flashes to indicate that the joystick is in speed limit mode. Speed limit mode limits the drive speed to a pre-programmed value, typically when the seat has been elevated and the wheelchair is required to drive at 20% speed.

Speed Control Buttons

The speed control buttons (tortoise button () and hare button (

I. To adjust the speed, perform one of the following:

- Adjust Speed in 20% Increments (5 Speed Mode) - Press the tortoise button () or hare button () to decrease/increase the speed in 20% increments. The larger bars in the speedometer will light.
- Adjust Speed in Smaller Increments (VSP Mode) - Perform the following steps:
 - i. Press and hold both the tortoise button () and hare button () until the joystick beeps.
 - ii. Perform one of the following:
 - Press the tortoise button () or hare button () to decrease/increase the speed in 20% increments. The larger bars in the speedometer will light.
 - Press and hold the tortoise button () or hare button () to decrease/increase the speed in smaller increments. The smaller bars in the speedometer will light.

7 WHEELCHAIR OPERATION

Joystick

The joystick has proportional drive control, meaning that the further the joystick is pushed from the upright (neutral) position, the faster the wheelchair or seat moves. Your top speed, however, is limited by the programmed settings.

To slow the wheelchair to a stop, simply release the joystick. The wheelchair has automatic speed and direction compensation to minimize corrections.

Charger/Programming Input

The charger/programming input is located at the front of the joystick housing. This provides easy access for charging the wheelchair batteries. This port also serves as the Remote Programmer Communication connection. Driving is prevented while the system is charging.

Information Gauge Display

The information gauge display is located on the front of the joystick housing and provides the following information to the user on the status of the wheelchair:

1. Power is On.
2. True state-of-battery-charge, including notification of when the battery requires charging:
 - A. GREEN LEDs are lit, indicating well charged batteries.
 - B. AMBER LEDs are lit, indicating batteries are moderately charged. Recharge batteries before taking a long trip.
 - C. RED LEDs are lit, indicating batteries are running out of charge. Recharge batteries as soon as possible.

The Information Gauge display also serves as a system diagnostic device when a fault is detected by the control module. A specific number of flashes of the LEDs indicate the type of fault detected. Refer to [Information Gauge Display Diagnostics](#) on page 115 for the diagnostic indications of the wheelchair status.

Service Indicator

The AMBER service indicator  will light when an error or fault occurs. Refer to [Service Indicator Light Diagnostics](#) on page 116 for a listing of the flash codes and what they indicate.

7.3 CMPJ+ Joystick Switches and Indicators



For this procedure, refer to FIGURE 4.

On/Off - Drive Select Toggle Switch

The drive select toggle switch is located on the left side, below the LCD. The drive select position is momentary, meaning that it will return to the neutral position after a selection is made.

This switch allows the operator to select the type of operation or performance which best suits a particular control need or situation. The DRIVE 1 program uses performance values which are independent of those used for the DRIVE 2 or 3 or 4 program. As an example, an operator may have a control need for spasticity in the morning and a very different need in the afternoon. DRIVE 1 can be programmed for higher speeds and quicker response while DRIVE 2 can be programmed for slower speeds and less responsiveness or vice versa. The other two drive programs could be indoor and outdoor versions of DRIVE 1 and DRIVE 2.

Selecting the Drive Mode

1. Move the toggle up and release. DRIVE 1 will appear on LCD.
2. Move the toggle up and release again. DRIVE 2 will appear on LCD.
3. Move the toggle up and release again. DRIVE 3 will appear on LCD.
4. Move the toggle up and release again. DRIVE 4 will appear on LCD.
5. Move the toggle up and release one more time to select DRIVE 1.

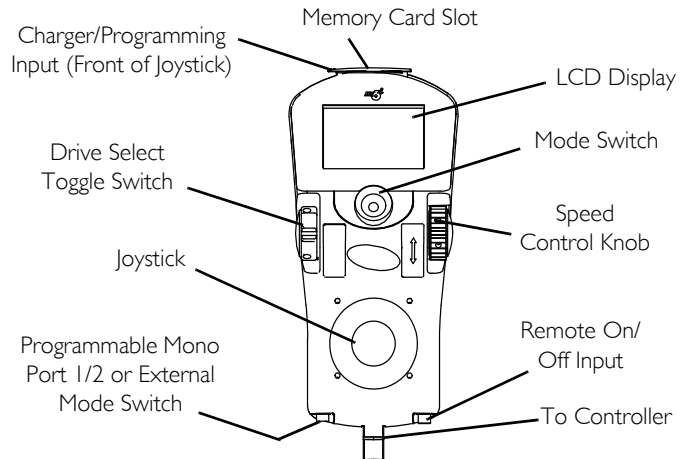

FIGURE 4 CMPJ+ Joystick Switches and Indicators

7 WHEELCHAIR OPERATION

Speed Control

The speed control knob is located on the side of the joystick housing.

1. Rotate the knob clockwise (forward) to increase the speed of the wheelchair to the programmed max speed.
2. Rotate the knob counterclockwise (backward) to decrease the speed of the wheelchair to the programmed max speed.

Joystick

The joystick has proportional drive control, meaning that the further the joystick is pushed from the upright (neutral) position, the faster the wheelchair or seat moves. Your top speed, however, is limited by the programmed settings.

To slow the wheelchair to a stop, simply release the joystick. The wheelchair has automatic speed and direction compensation to minimize corrections.

Charger/Programming Input

The charger/programming input is located at the front of the joystick housing. This provides easy access for charging the wheelchair batteries. This port also serves as the Remote Programmer Communication connection. Driving is prevented while the system is charging.

LCD Display Screens

The LCD Display is located in front of the joystick and provides information on the status of the wheelchair through a backlit display. The LCD display is readable in both bright sunlight and complete darkness.

Splash Screen



For this procedure, refer to FIGURE 5.

This screen is displayed at startup of the joystick for about 2 seconds. This screen displays the software version and date information.

After this screen, the joystick displays the Main Screen.



FIGURE 5 LCD Display Screens - Splash Screen

Main Screen







 For this procedure, refer to FIGURE 6 on page 61.

During normal operation, the active drive is displayed in the upper half of the LCD display. Battery charge level is shown in the Battery Gauge Display (BGD) located on the right side of the LCD display. At full charge, solid blocks fill in all ten segments between E (Empty) and F (Full). As the battery becomes discharged, the top most segments will progressively disappear until no segments appear between E and F. At this level, the user should charge the batteries as soon as possible.











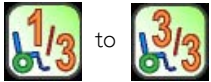



The lower half of the LCD display is the Information Center. The Information Center displays current data on the wheelchair.

Refer to LCD Display table on page 59 for descriptions of information shown.

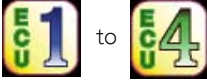
LCD DISPLAY

ITEM	DESCRIPTION
<p>DRIVE NAME</p>	<p>This field shows the currently selected Drive's Name. Available choices are as follows:</p> <p style="text-align: center;">Color CMPJ+</p> <div style="text-align: center;">      </div> <p style="text-align: center;">Drive 1* Drive 2* Drive 3* Drive 4* "No Drive**"</p> <p> *Drive names can be customized. Actual drive names may display differently. **No Drive selected via the programmer.</p>
<p>BATTERY LEVEL INDICATOR</p>	<p>This symbol shows the Battery Level and will change depending on the available battery power. This indicator is shown on every screen.</p>

7 WHEELCHAIR OPERATION

ITEM	DESCRIPTION				
STATUS MESSAGE	This area displays status or instructions.				
CLOCK	Displays current time.				
STATUS INDICATOR	<p>The status indicator will show a “Warning” (exclamation point inside a triangle) indicator when the chair has a condition that requires attention.</p> <p>The status indicator will show a “STOP” sign when a serious condition exists. The chair will not be allowed to operate.</p> <p>The status indicator shows an Attendant Icon if the attendant’s override switch is active.</p>				
MODES	<p>The dotted-box shows the area that contains the available “modes” in the currently selected drive. The modes are programmed for each drive and are based upon the configuration of the chair.</p> <p>These modes are highlighted when the Mode is active. The operator changes modes by pressing the Mode Select Switch.</p> <p>The available modes are as follows:</p>				
 <p>Digital 3 Speed 1 - 3</p>	 <p>RIM Mode</p>	 <p>No Driving</p>	 <p>Automatic Positioning</p>	 <p>Powered Seating</p>	
 <p>4-Switch Level 1 (L1, L1 Latched)</p>	 <p>4-Switch Level 2 (L2, L2 Latched)</p>	 <p>Drive Select</p>	 <p>ECU Output Activated</p>	 <p>ASM 1</p>	
 <p>ASM 2</p>	 <p>Infrared</p>	 <p>Mouse</p>	 <p>Mouse B</p>		

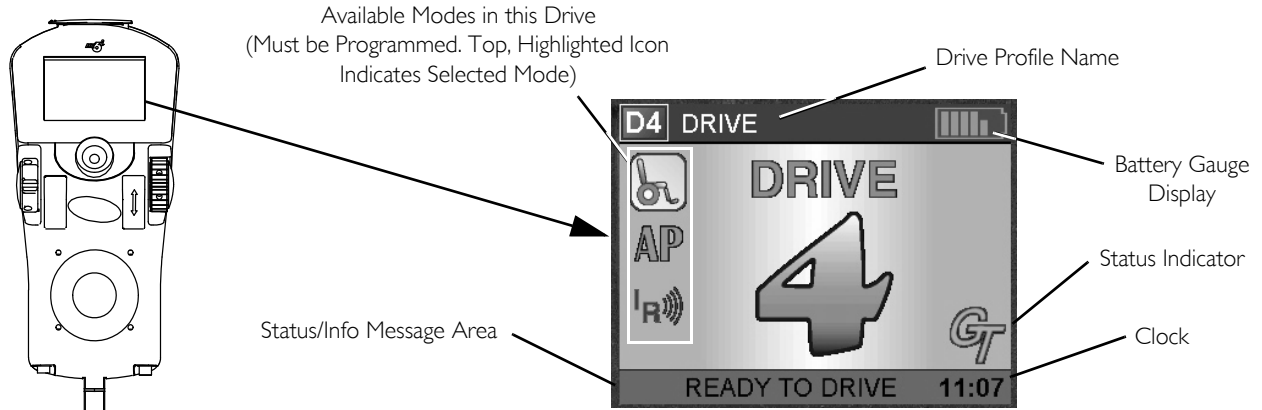

FIGURE 6 LCD Display Screens - Main Screen

Driving Screen

i For this procedure, refer to FIGURE 7.

This screen is shown when the operator issues a drive command and the Drive Icon on the main screen was highlighted.

i The Drive's name, warning/info message, status icon and battery indicator are displayed on this screen.



FIGURE 7 LCD Display Screens - Driving Screen

7 WHEELCHAIR OPERATION

User Settings

Depress the mode button of the CMPJ+ joystick for 10 seconds and the User Settings screen will appear with three choices. Move the joystick forward or reverse to scroll through list. Move the joystick to the right to select a user setting.

User Settings



Set Date and Time



Battery Voltage

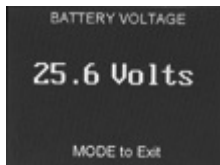

Fault Codes

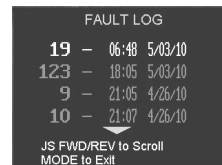

Connected Devices



USER SETTINGS

SET DATE AND TIME	<p>SET DATE AND TIME - Sets the clock on the color CMPJ+ joystick. Adds date and time stamp to error codes.</p> <ul style="list-style-type: none"> • Move the joystick Up or Down to change the highlighted value (hour, minute, AM/PM, month, day, year) • Move the joystick Right or Left to select a value or the Set icon. • Highlight the Set icon and move the joystick forward to enter new date and time.
BATTERY VOLTAGE	<p>BATTERY VOLTAGE - Displays current battery voltage. This is a diagnostic test a user can perform prior to a service call.</p>
FAULT CODE	<p>FAULT CODES - Displays time and date stamped fault codes. This information can be helpful to a provider prior to making a service call.</p>
CONNECTED DEVICES	<p>CONNECTED DEVICES - Displays device connections. Refer to Connected Devices Screen on page 63.</p>

Connected Devices Screen



For this procedure, refer to FIGURE 8.

This screen is displayed if the Mode Select switch is held active for about 10 seconds. This screen shows an icon that represents any additional devices that are connected to the chair.

Connected
Devices
Screen



ICON	DESCRIPTION
	Intelligent Tilt Actuator
	Intelligent Recline Actuator
	Intelligent Center Leg Actuator
	Elevate Actuator
	Generic Tilt Actuator
	Generic Recline Actuator

ICON	DESCRIPTION
	Generic Leg Actuators
	Generic Right Leg Actuator
	Generic Left Leg Actuator
	Intelligent CG Tilt
	Shark Power Module (SPM) Actuator
	SANODE or Single Actuator Control Interface
	4-way Switch Box
	Multiple Actuator Control Box

ICON	DESCRIPTION
	RIM Control
	ECU 1/2 and ECU 3/4
	Proportional Attendant Control
	Compact Joystick
	Sip and Puff control
	Digital Attendant Control
	Micro Extremity Control
	Peachtree Control
	ASL Digital Control

ICON	DESCRIPTION
	Generic Analog Control
	This is displayed if the controller supports G-Trac
	Mouse Only
	IR/Mouse

FIGURE 8 LCD Display Screens - Connected Devices Screen

7 WHEELCHAIR OPERATION

Programmable Mono Ports 1 and 2 with External Mode Switch

The programmable mono port with external mode switch input is located at the rear of the joystick on the left side. The programmable mono port input offers the choice of three options:

- Remote drive select
- Remote stop/mode (reset) input
- Single actuator input

The single switch functions operate through mono port 1. An optional y-cable allows a second programmable function through mono port 2.

Remote Stop Switch

The remote reset switch may be used to stop the wheelchair if the wheelchair is in motion.

The remote reset switch also functions in the same way as the joystick mode switch when the wheelchair is not in motion. Refer to [Mode Switch](#) on page 65.

Remote On/Off Switch

The remote On/Off switch input is located at the rear of the joystick on the right side and allows the power switch to be operated by an ability switch (normally open momentary switch with mono plug). To use the remote On/Off feature, the Drive Select/On/Off switch must be in the On position. Each activation of the ability switch will alternately turn the joystick On or Off.

Mode Switch

The mode switch is used to select the operating mode for the wheelchair. The mode switch is located on the joystick. A mode switch is needed whenever any of the following operating modes are programmed:

- Environmental Controls (ECU 1, ECU 2, ECU 3, ECU 4)*
- 3 Speed Mode in Digital 3 Speed (Slow, Medium, Full)
- Sleep Mode
- RIM Mode*
- Remote Drive Selection Mode*
- Tilt/Recline Mode*
- Information Center Display Selection (does not require Reset activation at power up)

If any of the above modes are selected, the control will require activation of the switch immediately after the power switch is turned On in order to enter the drive mode. The second line of the LCD will display - PRESS RESET.



*In these modes, Standby Select allows the reset switch to be bypassed for users unable to activate the switch.

Memory Card Slot

The memory card slot is used with the basic or professional memory card for saving or reading wheelchair parameters.

7.4 When to Charge Batteries



Keep Batteries charged. When possible, DO NOT allow battery charge to empty.

If battery charge becomes so low that no battery indicators are lit, allow the batteries to charge overnight.

7 WHEELCHAIR OPERATION

SPJ+, SPJ+ w/PSS and SPJ+ w/ACC Joysticks



For this procedure, refer to FIGURE 9.

The Information Gauge Display located on the front of the joystick housing, it provides the state-of-battery charge, including notification of when the battery requires charging. It also provides the following information to the user on the status of the wheelchair:

- A. GREEN LEDs are lit, indicating well charged batteries.
- B. AMBER LEDs are lit, indicating batteries are moderately charged. Recharge batteries before taking a long trip.
- C. RED LEDs are lit, indicating batteries are running out of charge. Recharge batteries as soon as possible.

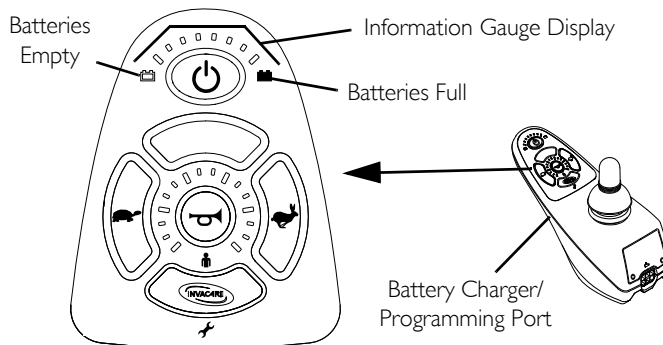

FIGURE 9 SPJ+, SPJ+ w/PSS and SPJ+ w/ACC Joysticks

CMPJ+ Joystick



For this procedure, refer to FIGURE 10.

The far right side of the display screen is the Battery Gauge Display (BGD). It provides information on the remaining charge in the batteries.

At full charge, solid blocks fill in battery gauge. As the battery becomes discharged, the segments will progressively disappear starting on the right and moving towards the left a bar at a time until no segments appear. At this level the user should charge the batteries as soon as possible.

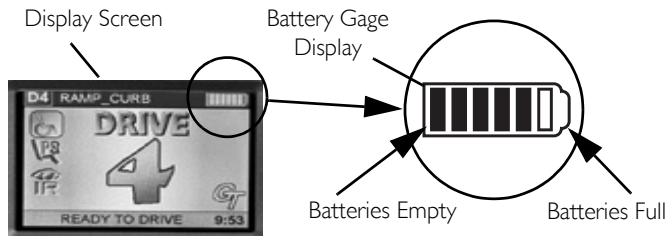

FIGURE 10 CMPJ+ Joystick

7.5 Charging Batteries



- New batteries MUST be fully charged prior to initial use to avoid reduced battery life.
 - Recharge daily and frequently to extend battery life and reduce charge time.
 - Charge battery when product will not be used for an extended period of time.
 - Avoid draining battery to low or empty levels.
 - Fully charge battery before use if the battery becomes fully drained.
 - If battery charge becomes so low that no battery indicators are lit, allow the batteries to charge overnight.
- All battery indicators will be lit at full charge. The battery discharges as power is used. Indicators will turn off as the battery discharges

The range per battery charge using recommended batteries should be approximately 5–9 hours of typical operation. Extensive use on inclines may substantially reduce per charge mileage.

Description and Use of Battery Chargers

The charger automatically reduces the charge from an initially high rate to a zero reading at a fully charged condition. If left unattended, the charger should automatically shut-off when full charge is obtained or enter a trickle charge mode to maintain the batteries depending on charger model.

Once the charger has been connected to the wheelchair and wall outlet and, if necessary, the charger has been turned on, the battery charger indicator lights will flash and light to show the battery charger status and condition of batteries to be charged. Refer to user's manual shipped with battery charger.

7 WHEELCHAIR OPERATION

Required Items:

- (I) Battery Charger—Supplied
1. Attach the battery charger connector to the charger port on the joystick.
 2. Plug the charger's AC power cord, or extension, into the grounded 120 VAC wall outlet.
 3. Wait until charging is complete.



Allow eight hours for normal charging. Larger batteries (greater than 55 ampere-hours) or severely discharged batteries may require up to sixteen hours to be properly charged and equalized.

If the batteries need to be charged more often or take longer to charge than normal, they may need to be replaced. Contact an Invacare dealer for service.

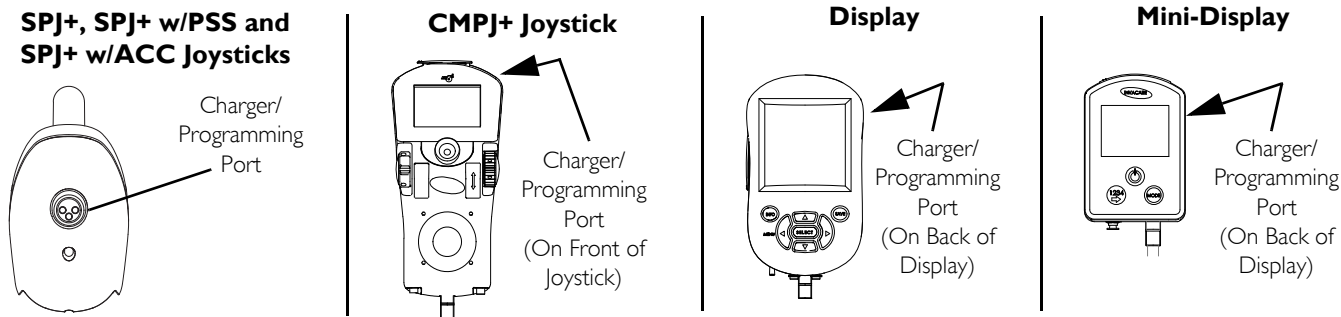

FIGURE 11 Charging Batteries

7.6 Disengaging/Engaging Motor Lock Levers



DANGER

Risk of Injury or Damage

Misuse of motor locks may result in injury or damage.

—DO NOT engage or disengage the motor locks until the power is in the off position.



Motor lock disengagement/engagement allows free wheeling or joystick controlled operation. Free wheeling allows an assistant to maneuver the wheelchair without power.

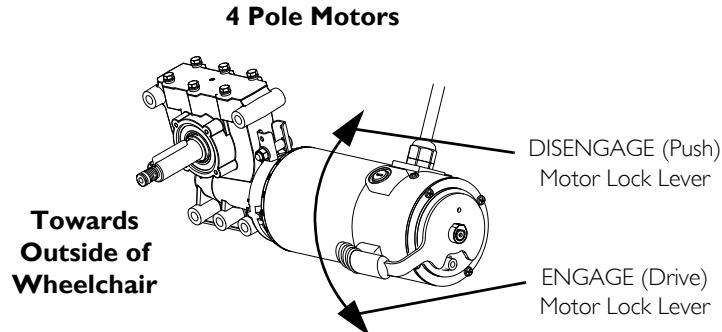

4 Pole Motors—Perform one of the following:

- Disengage (Push)—Pull motor lock levers upward.
- Engage (Drive)—Push motor lock levers downward.

7 WHEELCHAIR OPERATION

7.7 Disengaging/Engaging the Wheel locks

Engaging

1. Push handle forward away from tire to engage wheel lock.
2. Repeat STEP 1 for opposite wheel.

Disengaging

1. Pull handle back toward tire to disengage wheel lock.
2. Repeat STEP 1 for opposite wheel.

Disengaging/Engaging the Wheel locks

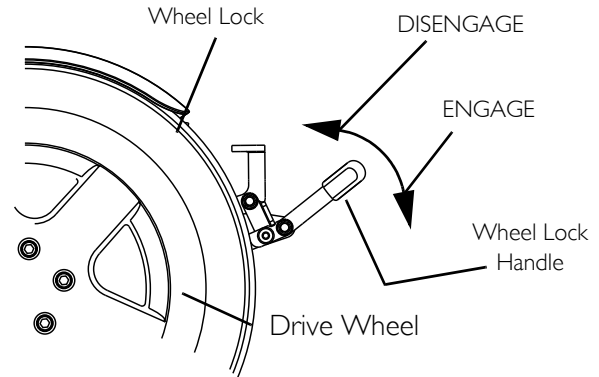

8 Transport in Vehicles



WARNING

Risk of Injury, Damage or Death

Failure to observe and follow transport warnings and instructions may result in injury, damage or death.

- Wheelchair occupants should transfer into the vehicle seat and use the OEM (Original Equipment Manufacturer) vehicle-installed restraint system.
- Ensure wheelchair is secured using proper restraint systems. Use **ONLY** Wheelchair Tie-down System which meet the requirements of the SAE (Society of Automotive Engineers) J2249 Recommended Practice during travel in a motor vehicle.
- Wheelchair-mounted accessories, including but not limited to IV poles, trays, respiratory equipment, backpacks, and other personal items should be removed and secured separately.
- Spill proof batteries, such as “gel cells”, should be installed on wheelchairs to be used during travel in a motor vehicle.
- Contact Invacare Corporation with any questions about using this wheelchair for seating in a motor vehicle.



WARNING

Risk of Injury, Damage or Death

Improper use of wheelchair transport brackets (TRBKTS) may result in injury, damage or death.

- Use these transport brackets only to secure an unoccupied wheelchair during transport.
- Ensure wheelchair is secured using proper restraint systems. Wheelchair transport brackets have not been crash-tested in accordance with ANSI/RESNA WC Vol I Section 19 Frontal Impact Test requirements for wheelchairs.
- Only use the transport brackets for the purposes described in this manual.

8 TRANSPORT IN VEHICLES

8.1 Wheelchair Transport Brackets (TRBKTS)

As of this date, the Department of Transportation has not approved any tie-down systems for transportation of a user while in a wheelchair, in a moving vehicle of any type. It is Invacare's position that users of wheelchairs should be transferred into appropriate seating in vehicles for transportation and use be made of the restraints made available by the auto industry. Invacare cannot and does not recommend any wheelchair transportation system.

TRBKTS includes four factory-installed wheelchair transport brackets. TRBKTS have not been crash-tested in accordance with WC 19. Use these transport brackets only to secure an unoccupied wheelchair during transport.

Securing the Wheelchair

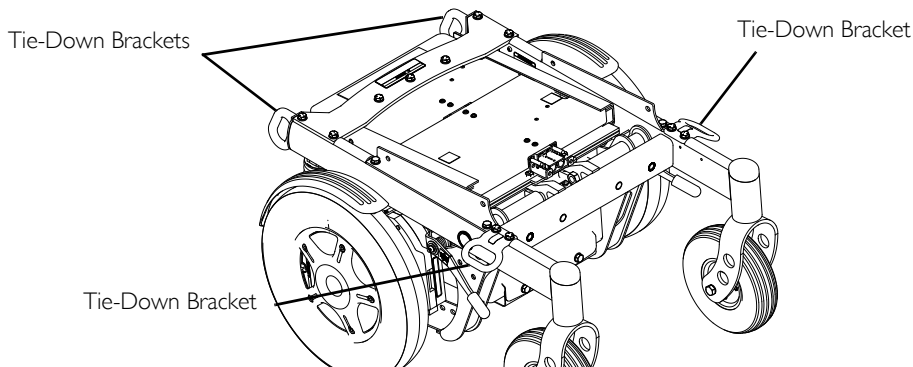

FIGURE 1

This wheelchair is to be used only with the Wheelchair Tie-down System that has been installed in accordance with the manufacturer's instructions and SAE J2249.



A copy of SAE J2249 Wheelchair Tie-down System for use in Motor Vehicles can be obtained from: SAE International, 400 Commonwealth Drive, Warrendale, PA 15096-0001, (877) 606-7232 or (724) 776-4970.

Battery support brackets **MUST** be installed correctly for wheelchairs equipped with wheelchair transport brackets (TRBKTS). Wheelchairs not installed with brackets are not compliant with ANSI/RESNA WC Vol I Section 19 Frontal Impact Test requirements for wheelchairs.

8.2 Transport Ready Option (TRRO)



As of January 1, 2017, TRRO (Transport Ready Option) has been discontinued on this product. Please contact your dealer or Invacare for legacy information or to answer questions regarding TRRO.

As of this date, the Department of Transportation has not approved any tie-down systems for transportation of a user while in a wheelchair, in a moving vehicle of any type. It is Invacare's position that users of wheelchairs should be transferred into appropriate seating in vehicles for transportation and use be made of the restraints made available by the auto industry. Invacare cannot and does not recommend any wheelchair transportation system.

This section applies only to wheelchairs equipped with TRRO



WARNING

Risk of Injury, Damage or Death

Failure to observe and follow transport warnings and instructions may result in injury, damage or death

- Use ONLY Occupant Restraint Systems (WTORS) which meet the requirements of the SAE (Society of Automotive Engineers) J2249 Recommended Practice during travel in a motor vehicle.
- The wheelchair MUST be in a forward facing position during travel in a motor vehicle.
- Only use the transport brackets included with TRRO or TRBKTS for the purposes described in this manual.
- This wheelchair is equipped, and has been dynamically tested to rely on WHEELCHAIR-ANCHORED pelvic belts. If desired, VEHICLE-ANCHORED pelvic belts may be used.
- Use both the pelvic and upper-torso belts.



WARNING

Risk of Injury, Damage or Death

Lack or Improper use of wheelchair transport systems may result in injury, damage or death.

- Use both pelvic and upper torso belts.
- The pelvic belt that is provided by Invacare has been tested for use in a motor vehicle on this wheelchair only. DO NOT replace the pelvic belt with a different style pelvic belt.

8 TRANSPORT IN VEHICLES

TRRO includes four factory-installed transport brackets and a wheelchair anchored pelvic belt.

- The wheelchair has been tested for seating in a motor vehicle with the factory installed seating system only.
- This wheelchair has been dynamically tested in a forward-facing mode with the specified crash test dummy restrained by BOTH pelvic and upper-torso belt(s) (shoulder belts), and that BOTH pelvic and upper torso belt(s) should be used to reduce the possibility of head and chest impacts with vehicle components.
- TRRO has been crash-tested in accordance with ANSI/RESNA WC Vol I Section 19 Frontal Impact Test requirements for wheelchairs with a 130 lb crash test dummy, which corresponds to a person with a weight of 125 to 165 lbs for junior seat sizes or a 168 lb crash dummy, which corresponds to a person with a weight of 165 to 300 lbs for adult seat sizes.
- The wheelchair is equipped, and has been dynamically tested to rely on WHEELCHAIR-ANCHORED pelvic belts. If desired, VEHICLE-ANCHORED pelvic belts may be used.

This wheelchair is to be used only with the Wheelchair Occupant Restraint System (WTORS) that has been installed in accordance with the manufacturer's instructions and SAE J2249.



A copy of SAE J2249 Wheelchair Occupant Restraint System (WTORS) for use in Motor Vehicles can be obtained from: SAE International, 400 Commonwealth Drive, Warrendale, PA 15096-0001, (877) 606-7232 or (724) 776-4970.

Attach WTORS to the tie-down brackets in accordance with the manufacturer's instructions and SAE J2249.



Battery support brackets **MUST** be installed correctly for wheelchairs equipped with transport ready option (TRRO) and/or wheelchair transport brackets (TRBKTS). Wheelchairs not installed with brackets are not compliant with ANSI/RESNA WC Vol I Section 19 Frontal Impact Test requirements for wheelchairs.

Wheelchairs with adjustable seat angles **MUST** be set to 10°. Seat angle is factory set at time of shipment. Adjustments to the wheelchair may void WC 19 compliance. To maintain compliance, refer to wheelchair service manual before making any adjustments

Contact Invacare Corporation with any questions about using this wheelchair for seating in a motor vehicle.

8.3 Compliance Information

This wheelchair conforms with the requirements of the ANSI/RESNA WC/Vol. 1 - Section 19 (Frontal Impact Test)



ANSI = American National Standards Institute

RESNA= Rehabilitation Engineering and Assistive Technology Society of North America

This wheelchair has been dynamically tested in a forward-facing mode with a 130 lb crash test dummy, which corresponds to a person with a weight of 125 to 165 lbs for junior seat sizes or a 168 lb crash test dummy, which corresponds to a person with a weight of 165-300 pounds for adult seat sizes, restrained by BOTH pelvic and shoulder belts in accordance with ANSI/RESNA WC Vol 1 Section 19. BOTH pelvic and upper torso belts should be used to reduce the possibility of head and chest impacts with vehicle components.

8.4 Specifications

MODEL	MOTOR	WHEELCHAIR WEIGHT LIMIT	
		ADULT	JUNIOR
Arrow	GB	Up to 400 lbs	Up to 150 lbs
Torque SP	GB	Up to 300 lbs	Up to 150 lbs
Torque SP	4 Pole	Up to 300 lbs	Up to 150 lbs
Torque SE	4 Pole	Up to 300 lbs	Up to 150 lbs
Torque 3	4 Pole	Up to 300 lbs	Up to 150 lbs
Ranger X	GB	Up to 300 lbs	N/A
Ranger X	4 Pole	Up to 300 lbs	N/A

8 TRANSPORT IN VEHICLES

Positioning the Wheelchair in the Vehicle

This wheelchair **MUST** be in a forward facing position during travel in a motor vehicle.

The recommended clear zones for wheelchair seated occupants restrained by **BOTH** pelvic and upper torso belt(s) and **ONLY** by a pelvic belt are shown in the diagrams and described below.

Frontal Clear Zones (FCZ) need to be **LARGER** when upper torso belt(s) are **NOT** used.

The rear clear zone of 16-inches is measured from the rearmost point on an occupant's head.

The frontal clear zone is measured from the frontmost point on an occupant's head and is 26-inches with pelvic and upper-torso belt(s) and 37-inches with **ONLY** a pelvic belt.

The frontal clear zone may not be achievable for wheelchair-seated drivers.

The estimated seated height (HHT) from the ground or floor to the top of the wheelchair-seated occupant's head ranges from approximately 47-inches for a small adult female to about 61-inches for a tall adult male.

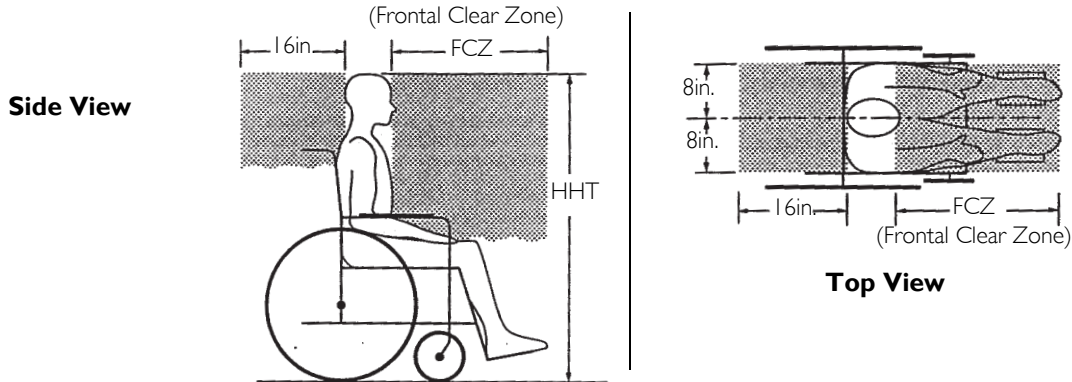

8.5 Securing the Occupant

Wheelchair-Anchored Belts



For this procedure, refer to FIGURE 2 on page 78.

The wheelchair has been provided with a pelvic belt which meets the requirements of ANSI/RESNA WC/19.

The pelvic belt provided by Invacare has been designed to accommodate use on either side of the vehicle. If necessary, follow the instructions below to reverse the orientation of the pelvic belt to accommodate the vehicle-anchored upper torso belt.

1. Install the pelvic belt pin (Detail A) into slot in the pelvic belt bracket (Detail B or Detail C). Pull upwards until it snaps into place.



Both ends of the pelvic belt have a pin which is used to secure the vehicle-anchored upper torso belt.

2. Repeat STEP 1 for the opposite pelvic belt bracket.
3. Install the vehicle-anchored upper torso belt onto the pin located at either end of the pelvic belt.

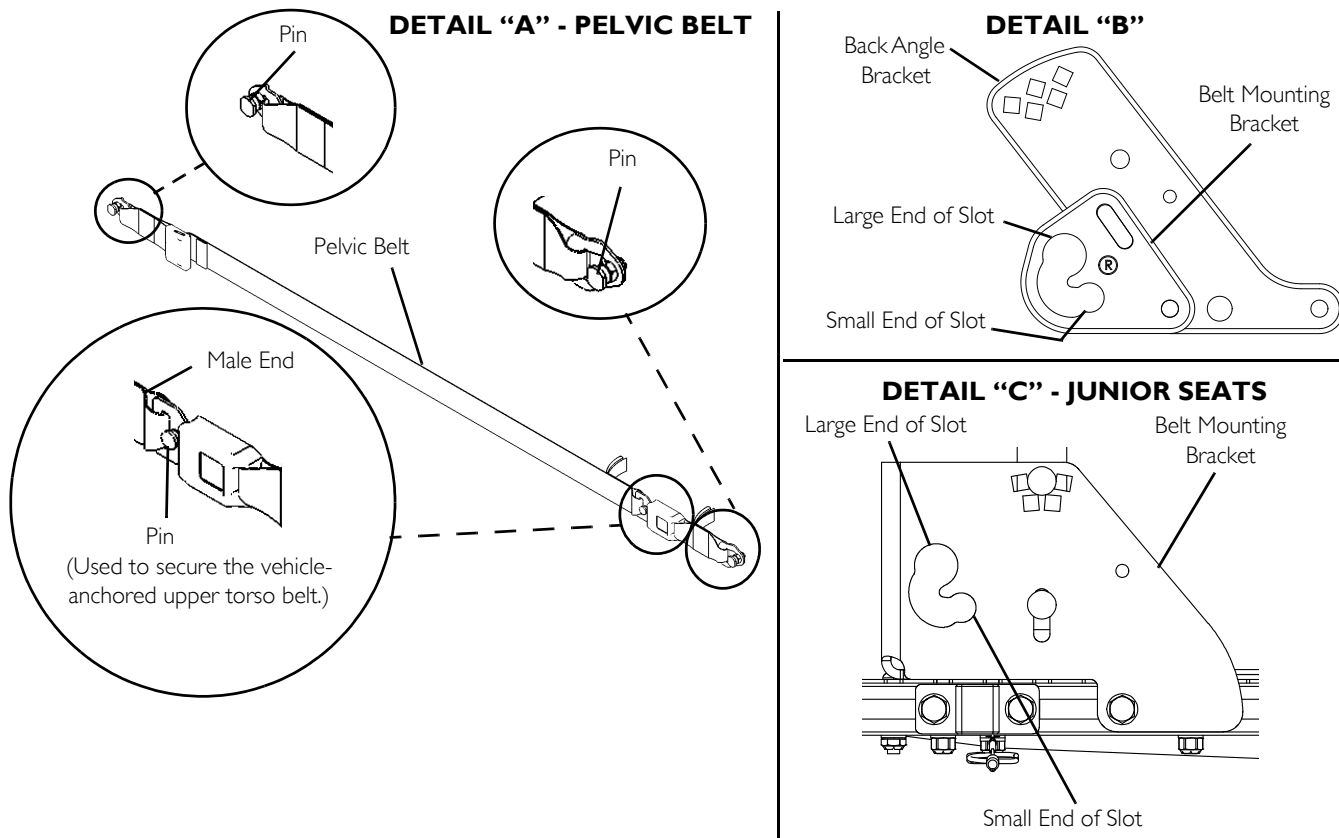

FIGURE 2 Wheelchair-Anchored Belts

Vehicle-Anchored Belts



For this procedure, refer to FIGURE 3.

This wheelchair has an overall rating of “A” with regard to accommodating the use and fit of vehicle-anchored belts. This rating is scored as follows:

RATING	DESCRIPTION
A	Excellent
B	Good
C	Fair
D	Poor

The test for Lateral Stability Displacement for Point (P) is shown in FIGURE 3. The average test result for point (P) is:

- Adult - 0.48 inches (12.3 mm).
- Junior - 0.54 inches (13.7 mm)

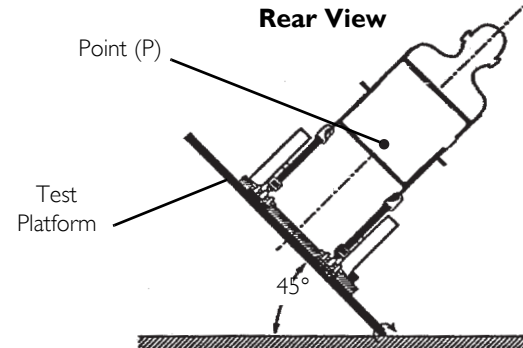

NOTE: Rear view of wheelchair and human surrogate secured on test platform and tilted to 45 degrees.

FIGURE 3 Vehicle-Anchored Belts

8 TRANSPORT IN VEHICLES

Seating System

Ensure that the factory installed seating system is secured to the wheelchair frame before operation. Refer to the seating system user's manual.

Positioning Belts

The angle of the pelvic belt should be within the preferred zone of 45 to 75 degrees to the horizontal OR within the optional zone of 30 to 45 degrees to the horizontal. Steeper side-view pelvic belt angles are especially important if the pelvic belt is intended to be used for postural support in addition to occupant restraint in a frontal crash. Steeper angles will reduce the tendency for a vertical gap to develop between the user and the belt due to compliance of seat cushions and belt movement, thereby reducing the tendency for the user to slip under the belt and for the belt to ride up on the soft abdomen during normal use.

Steeper belt angles also reduce the tendency for upper-torso belts to pull the pelvic belt onto the abdomen during frontal impact loading.

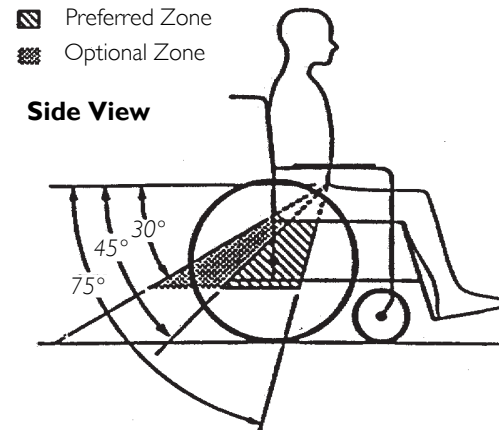

1. The pelvic belt should be worn low across the front of the pelvis.
2. Position the upper torso belt(s) over the shoulders.
3. The belt(s) should not be held away from the body by wheelchair components or parts, including but not limited to wheelchair armrests or wheels. Refer to FIGURE 4 for proper and improper positioning of the belts.
4. Ensure the belt(s) are not be twisted.
5. Adjust belts as firmly as possible, being mindful of user comfort.

DO position belts **INSIDE** of armrests, wheels, etc.

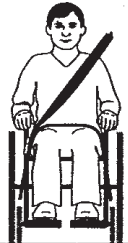

DO NOT position belts **OUTSIDE** of armrests, wheels, etc.

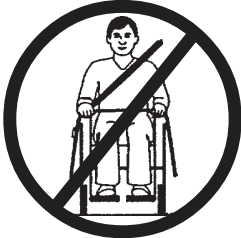

FIGURE 4 Positioning Belts

9 Setup/Maintenance



DANGER

Risk of Injury, Damage or Death

Improper setup, service, adjustment or programming may cause injury, damage or death.

- Qualified technician **MUST** setup, service and program the wheelchair.
- DO NOT** allow non-qualified individuals to perform any work or adjustments on the wheelchair.
- DO NOT** setup or service the wheelchair while occupied except for programming or unless otherwise noted.
- Turn off power **BEFORE** adjusting or servicing the wheelchair. Note that some safety features will be disabled.
- Ensure all hardware is securely tightened after setup, service or adjustments.



DANGER

Risk of Death or Serious Injury

Not performing periodic maintenance on stability lock could result in death or serious injury.

ALWAYS perform the periodic maintenance to the stability lock listed in the inspection checklist of this manual.



DANGER

Risk of Death or Serious Injury

Failure to complete the inspection of the critical components listed below could result in death or serious injury.

Inspect stability control components which could include anti-dive spring, anti-dive cylinder, ratcheting gears, or end stops to ensure proper operation.

Inspect drive axle nut, locking tab, wheel fasteners or quick release to ensure drive wheel is secure.

**CAUTION****Risk of Injury or Damage**

Cleaning or maintenance may cause damage to carpeting or flooring.

- Place the wheelchair in a well ventilated area where cleaning or maintenance can be performed without risk of damage to carpeting or flooring.

**WARNING****Risk of Injury or Damage**

Grease may leak from the gearbox and cause injury or damage from falling or fire.

- Follow the maintenance instructions in this manual.
- Routinely inspect the gearbox for grease leakage.

If the gearbox is leaking grease:

- Stop use immediately.
- Keep the product away from sparks, flame, and open heat sources.
- Contact your dealer or Invacare for repair.

9 SETUP/MAINTENANCE

9.1 Setup/Delivery Inspection



Setup/delivery inspection should be performed by dealer at time of delivery/set up.

Initial adjustments should be made to suit your personal body structure needs and preference. Thereafter weekly, monthly and periodic inspections should be performed by user/attendant between the six month service inspections.

Every six months, and as necessary, take your wheelchair to a qualified technician for a thorough inspection and servicing.

Warranty is void if non-qualified individual(s) perform any work on this product.



WARNING

Risk of Injury or Damage

Missing or damaged parts may result in injury or damage.

—Check ALL product components and carton for damage, and test components before use. In case of damage, or if the wheelchair is not working properly, contact a qualified technician or Invacare for repair.

—DO NOT store or use wheelchair near combustible products.

- Check all parts for shipping damage. In case of damage, DO NOT use.
- Ensure wheelchair rolls straight (no excessive drag or pull to one side).
- Ensure clothing guards are secure
- Ensure arms are secure but easy to release and adjustment levers engage properly.
- Adjustable height arms operate and lock securely.
- Ensure axle nut or bolt and wheel mounting nuts are secure on drive wheels.
- Ensure caster/anti-tipper wheels are free of debris, and all mounting hardware is secure and not damaged/missing.
- Check that cables are routed and secured properly to ensure that cables DO NOT become entangled and damaged during normal operation of seating system.
- Ensure proper operation of powered functions (Example: drive, seating and legrests).

9.2 User/Attendant Inspection Checklists



Every six months, and as necessary, take your wheelchair to a qualified technician for a thorough inspection and servicing. Service inspections **MUST** be performed by a qualified technician. Weekly, monthly and periodic inspections should be performed by user/attendant between six month service inspections. Regular cleaning will reveal loose or worn parts and enhance the smooth operation of your wheelchair. To operate properly and safely, your wheelchair must be cared for just like any other vehicle. Routine maintenance will extend the life and efficiency of your wheelchair.



CAUTION

Risk of Injury or Damage

Exposure to liquids may damage components or accessories of wheelchair and electronics.

- DO NOT spray with any type of water or liquid.
- Electrical components damaged by corrosion **MUST** be replaced immediately.

Inspect/Adjust Weekly

- Ensure that the casters are free of debris.
- Inspect tires for flat spots and wear.
- Inspect all fasteners.
- Inspect TRBKTS fasteners and hardware.
- Inspect the anti-tippers for loose hardware or damage.
- Ensure proper operation of powered functions (Example: drive, seating and legrests).

9 SETUP/MAINTENANCE

Inspect/Adjust Monthly

- Clean upholstery and armrests.
- Clean dirt and lint from axles.
- Clean dirt and lint from bearings.
- Ensure that the casters are free of debris.
- Inspect seat positioning strap for any signs of wear. Ensure buckle latches. Verify hardware that attaches strap to frame is secure and undamaged. Replace if necessary.

Inspect/Adjust Periodically

- Ensure wheelchair rolls straight (no excessive drag or pull to one side).
- Inspect all operator (user/attendant) adjustable fasteners including back pan, back cane and angle adjustment fasteners, the arm support and flip back and height adjustment fasteners. Ensure fasteners are securely tightened.
- Inspect TRBKTS fasteners and hardware.
- Ensure clothing guards are secure.
- Ensure arms are secure but easy to release and adjustment levers engage properly.
- Adjustable height arms operate and lock securely.
- Ensure upholstery does not have any rips or tears.
- Armrest pad sits flush against arm tube.
- Ensure that the casters are free of debris.
- Inspect foam handgrips for damage. If damaged, have them replaced by a qualified technician.
- Check center mount front riggings for loose fasteners. Replace /tighten if necessary.
- Check that all labels are present and legible. Replace if necessary.

9.3 Cleaning



WARNING

Risk of Injury, Damage or Death

Electrical shock may cause injury, damage or death.

- Always unplug the product from the electrical outlet before cleaning.
- Always unplug accessories from the electrical outlet before cleaning.



Regular cleaning will reveal loose or worn parts and enhance the smooth operation of your wheelchair. To operate properly and safely, you wheelchair must be cared for just like any other vehicle.

For upholstery that is severely stained or surface finish that is badly damaged, contact Invacare for further information.

Cleaning—Use the following instructions to clean this product unless otherwise specified.

- Upholstery—Warm water and mild non-abrasive soap
- Metal—Hot water and mild non-abrasive soap. Car polish and soft wax may be used to remove abrasions and restore gloss.
- Plastic—Hot water and mild non-abrasive soap.
- Dry surface with dry cloth.
- DO NOT use solvents or kitchen cleaners.

9 SETUP/MAINTENANCE

9.4 Service Inspection



Every six months take your wheelchair to a qualified technician for a thorough inspection and servicing. Service inspections **MUST** be performed by a qualified technician.

The following are recommended items to inspect during regular service inspections performed by a qualified technician. Actual items to be inspected during the service inspection may vary according to the specific wheelchair:

Six Month Inspection

- Clean upholstery and armrests.
- Clean dirt and lint from axles.
- Clean dirt and lint from bearings.
- Check that all labels are present and legible. Replace if necessary.
- Ensure clothing guards are secure.
- Ensure adjustable height arms operate and lock securely.
- Ensure upholstery does not have any rips or tears.
- Ensure armrest pad sits flush against arm tube.
- Ensure arms are secure but easy to release and adjustment levers engage properly.
- Inspect seat positioning strap for any signs of wear. Ensure buckle latches. Verify hardware that attaches strap to frame is secure and undamaged. Replace if necessary.
- Ensure wheelchair rolls straight (no excessive drag or pull to one side).
- Ensure that there is no excessive side movement or binding when drive wheels are lifted and spun when disengaged (free-wheeling).
- Ensure axle nut or bolt and wheel mounting nuts are secure on drive wheels.
- Inspect tires for flat spots and wear.
- Ensure that the casters are free of debris.
- Ensure wheels/casters have proper tension when wheels/casters are spun (when free-wheeling). Wheels/casters should come to a gradual stop.
- Loosen/tighten caster locknut if wheel wobbles noticeably or binds to a stop.

- Ensure all caster/wheel/fork/headtube fasteners are secure and not damaged/missing.
- Inspect the anti-tippers for loose hardware or damage.
- Ensure the anti-tipper wheels are properly installed and located in the proper mounting position.
- Ensure wheel locks DO NOT interfere with tires when rolling.
- Ensure wheel lock pivot point are free of wear and looseness.
- Ensure wheel locks are easy to engage.
- Check center mount front riggings for loose fasteners. Replace /tighten if necessary.
- Check that cables are routed and secured properly to ensure that cables DO NOT become entangled and damaged during normal operation of seating system.
- Ensure proper operation of powered functions (drive, seating, legrests, etc.).
- Inspect motor brushes and gearbox coupling.
- Inspect electrical components for signs of corrosion. Replace if corroded or damaged.
- Inspect battery terminals for loose cable connection. Tighten if necessary.
- Inspect all fasteners.
- Inspect TRBKTS fasteners and hardware.
- Inspect foam handgrips for damage. If damaged, have them replaced by a qualified technician.
- Ensure swingarm stops are in place and not deteriorated or damaged. Replace if necessary.
- Check pneumatic tires for proper inflation.
- Check power center mount front riggings for worn/frayed straps and/or loose fasteners. If found, replace these items.

Inspect/Adjust Every 18 Months

- Replace motor brushes and gearbox coupling.

9 SETUP/MAINTENANCE

9.5 Batteries



WARNING

Risk of Death or Serious Injury

Failure to observe these warnings can cause an electrical short resulting in death, serious injury, or damage to the electrical system.

The POSITIVE (+) RED battery cable MUST connect to the POSITIVE (+) battery terminal(s)/post(s).

The NEGATIVE (-) BLACK battery cable MUST connect to the NEGATIVE (-) battery terminal(s)/post(s).

NEVER allow any of your tools and/or battery cable(s) to contact BOTH battery post(s) at the same time.

An electrical short may occur and serious injury or damage may occur.

Install protective caps on positive and negative battery terminals.

Replace cable(s) immediately if cable(s) insulation becomes damaged.

DO NOT remove fuse or mounting hardware from POSITIVE (+) red battery cable mounting screw.



WARNING

Risk of Injury

Exposure to battery acid may result in injury.

—The use of rubber gloves is recommended when working with batteries.

—DO NOT allow the liquid in the battery to come in contact with skin, clothes or other possessions. It is a form of acid and harmful or damaging burns may result. Should the liquid touch your skin, wash the area IMMEDIATELY and thoroughly with cool water. In serious cases or if eye contact is made, seek medical attention IMMEDIATELY.

—DO NOT install/reinstall a battery with a cracked or otherwise damaged case.



Invacare strongly recommends battery installation and replacement be performed by a qualified technician.

- Read the installation instructions noted on the battery and in the manual.
- Ensure there is no battery acid in the bottom or around the battery box or on the sides of the battery(ies). Neutralize battery acid with baking soda if found.
- Clean battery tray and batteries prior to installation.
- Use battery lifting strap when available.
- Keep batteries in an upright position and avoid tipping.
- Use only deep cycle gel cell battery.
- Use box wrench when tightening clamps. **DO NOT** wiggle the battery terminals/posts when tightening.



Failure to use the correct battery size and/or voltage may cause damage to your wheelchair and give you unsatisfactory performance. The warranty and performance specifications contained in this manual are based on the use of deep cycle gel cell batteries. Invacare strongly recommends their use as the power source for this unit.

9 SETUP/MAINTENANCE

9.6 Using the Proper Batteries



WARNING

Risk of Injury or Damage

Improper configuration of battery terminals may cause injury or damage.

- Batteries with terminal configuration as shown **MUST** be used.
- Terminals **MUST** have a cross hole in them as shown.
- The **POSITIVE (+) RED** battery cable **MUST** connect to the **POSITIVE (+)** battery terminals/posts
- The **NEGATIVE (-) BLACK** battery cable **MUST** connect to the **NEGATIVE (-)** battery terminals/posts.
- Terminals **MUST** have a cross hole in them as shown.
- DO NOT** allow any of your tools and/or battery cables to contact both battery terminals at the same time

1. Position battery on ground/flat surface.
2. Visually inspect the battery to ensure proper polarity

GP24 Battery

Proper Battery to be Used
NEGATIVE (-) POSITIVE (+)

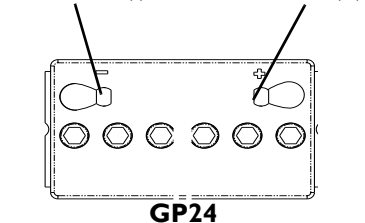

DO NOT USE

POSITIVE (+) NEGATIVE (-)

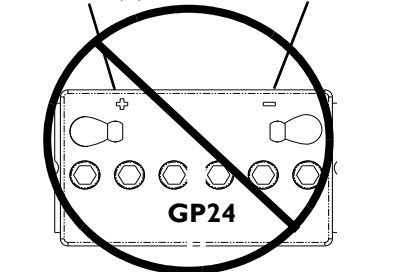

9.7 Recommended Battery Types



Both battery sizes are deep cycle batteries.

Charge batteries daily. It is critical not to let them run low at any time.

The warranty and performance specifications contained in this manual are based on the use of deep cycle gel cell batteries. Invacare strongly recommends their use as the power source for this unit.

BATTERY REQUIREMENTS AND WEIGHT LIMITATIONS

MODEL	WEIGHT LIMITATION	MOTOR	BATTERY
TORQUE SP	Up to 300 lbs	4 Pole Motor or GB	*Group 24
TORQUE 3	Up to 300 lbs	4 Pole Motor	*Group 24



*Two batteries inside one battery box.

Weight limitation is total weight (user weight plus any additional items that the user may require [back pack, etc.]). Example: If weight limitation of the wheelchair is 300 lbs and additional items equal 25 lbs, subtract 25 lbs from 300 lbs. This means the maximum weight limitation of the user is 275 lbs.

9 SETUP/MAINTENANCE

9.8 Replacing Batteries



Invacare recommends that both batteries be replaced if one battery is defective.

1. Remove the battery box(es) from the wheelchair. Refer to one of the following procedures:
 - [Removing/Installing Battery Boxes](#) on page 95.
 - [Installing/Removing Batteries Into/From Battery Boxes](#) on page 100.
2. Remove existing batteries from the battery box(es). Refer to [Installing/Removing Batteries Into/From Battery Boxes](#) on page 100.
3. Clean the new battery terminals. Refer to [Battery Terminals](#) on page 101.
4. Install the new batteries into the battery box(es). Refer to [Installing/Removing Batteries Into/From Battery Boxes](#) on page 100.



WARNING

Risk of Damage

Use of wrong battery type or size may cause damage.

- DO NOT force a battery into place.
- Batteries with molded straps or flanges that interfere with proper battery placement should not be used.
- Use batteries called out in this manual for proper replacement.



WARNING

Risk of Injury, Damage or Death

Loose or missing retainer resulting in disconnection of wiring may cause injury, damage or death resulting from erratic wheelchair operation.

- Ensure battery retainer is in locked position.
- DO NOT use wheelchair if erratic operation occurs. Contact qualified service technician or Invacare for assistance.

9.9 Removing/Installing Battery Boxes

Group 24 Wheelchairs without Vent Tray



For this procedure, refer to FIGURE I on page 97.

Removing

1. Place the wheelchair in a well ventilated area where work can be performed without risking damage to carpeting or floor covering.
2. Verify the joystick On/Off switch is in the Off position.
3. Wheelchairs with TRRO or TRBKTS Only—Perform the following steps:
 - A. Remove the three bolts and washers that secure the front battery retainer bracket (Detail “A”).
 - B. Remove the three short hex screws that secure the top battery retainer bracket to the lower battery retainer bracket.
 - C. Remove the four long hex screws and washers that secure the top battery retainer bracket to the rear of the wheelchair frame (Detail “B”).
 - D. Remove the top battery retainer bracket.
 - E. Remove the lower battery retainer bracket.
4. Rotate the levers of the battery retainer assembly to the unlocked position.
5. Lift battery retainer assembly up off the mounting screws that secure the shocks to the base frame.
6. Slide one connector battery box along the sub-frame and remove from the wheelchair.
7. Slide the two connector battery box along the sub-frame and remove from the wheelchair.

Installing

1. Place the wheelchair in a well ventilated area where work can be performed without risking damage to carpeting or floor covering.
2. Verify the joystick On/Off switch is in the Off position.
3. Secure the battery box carrying strap to the lid of the two connector battery box.
4. Place two connector battery box onto the battery sub-frame assembly with guide pins facing the inside of the wheelchair.
5. Slide the two connector battery box along the sub-frame until its guide pins are engaged in the sub-frame connector.

9 SETUP/MAINTENANCE



Visually inspect to ensure the connection is properly made. Connectors **MUST** be fully engaged.

Make certain that the battery box carrying strap is positioned on top of the battery box and will not interfere with the one connector battery box guide pins when engaging the connector on the one battery box lid.

6. Secure the battery box carrying strap to the lid of the one connector battery box.
7. Place one connector battery box onto battery sub-frame.
8. Slide one connector battery box along the sub-frame until its guide pins are engaged in the connector of the two connector battery box.



Visually inspect to ensure the connection is properly made. Connectors **MUST** be fully engaged.

9. Place the battery retainer assembly on head portion of the mounting screws that secure the shocks to the base frame.
10. Rotate the levers of the battery retainer assembly to the locked position.
11. Wheelchairs with TRRO or TRBKTS Only—Perform the following steps:
 - A. Position the lower battery retainer bracket as shown in Detail “A” of FIGURE 1.
 - B. Install the top battery retainer bracket onto the wheelchair frame using four long hex screws and washers. Torque to 13 ft-lbs.
 - C. Secure the top battery retainer bracket to the lower battery retainer bracket using three short hex screws and washers. Torque to 13 ft-lbs.
 - D. Install the front battery retainer bracket using three bolts and washers. Torque to 13 ft-lbs.

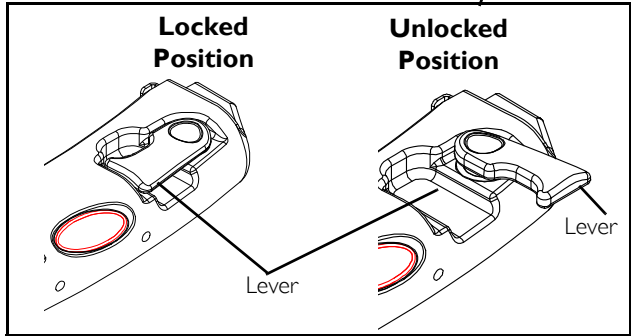
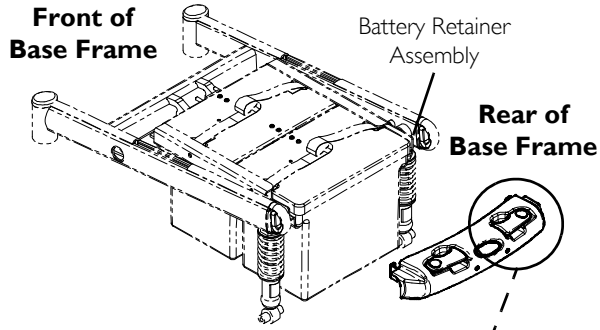

DETAIL "A" - WHEELCHAIRS WITH TRRO OR TRBKTS

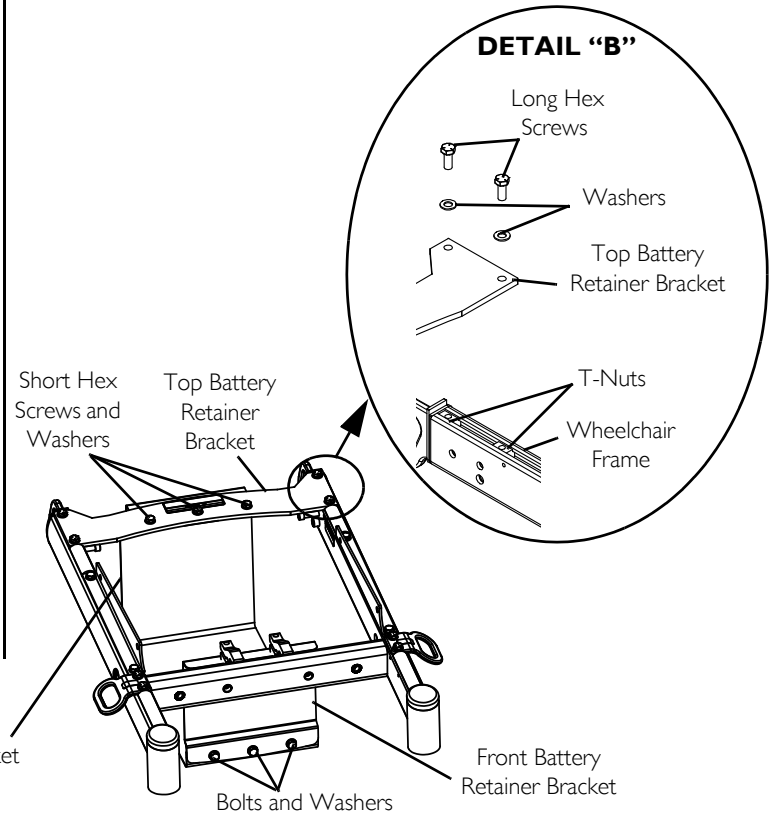

FIGURE I Removing/Installing Battery Boxes - Group 24 Wheelchairs without Vent Tray

9 SETUP/MAINTENANCE

Group 24 Wheelchairs with Vent Tray

Removing

1. Place the wheelchair in a well ventilated area where work can be performed without risking damage to carpeting or floor covering.
2. Verify the joystick On/Off switch is in the Off position.
3. Pull the battery box retainer Up over the end of the one connector battery box.
4. Slide one connector battery box along the sub-frame and remove from the wheelchair.
5. Slide the two connector battery box along the sub-frame and remove from the wheelchair.

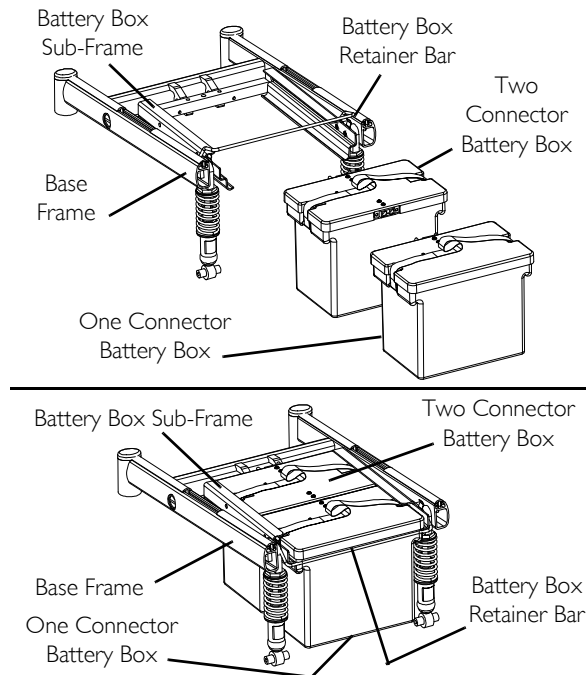

FIGURE 2 Group 24 Wheelchairs with Vent Tray

Installing

1. Place the wheelchair in a well ventilated area where work can be performed without risking damage to carpeting or floor covering.
2. Verify the joystick On/Off switch is in the Off position.
3. Secure the battery box carrying strap to the lid of the two connector battery box.
4. Place two connector battery box onto the battery sub-frame assembly with guide pins facing the inside of the wheelchair.
5. Slide the two connector battery box along the sub-frame until its guide pins are engaged in the sub-frame connector.



Visually inspect to ensure the connection is properly made. Connectors **MUST** be fully engaged.

Make certain that the battery box carrying strap is positioned on top of the battery box and will not interfere with the one battery box guide pins when engaging the connector on the one battery box lid.

6. Secure the battery box carrying strap to the lid of the one connector battery box.
7. Place one connector battery box onto battery sub-frame.
8. Slide one connector battery box along the sub-frame until its guide pins are engaged in the connector of the two connector battery box.
9. Pull the battery box retainer down over the end of the one connector battery box until it is securely clipped (locked) into place.

9 SETUP/MAINTENANCE

9.10 Installing/Removing Batteries Into/From Battery Boxes



For this procedure, refer to FIGURE 3 on page 101.

If there is battery acid in the battery boxes or on the sides of the battery, apply baking soda to these areas to neutralize the battery acid. Before reinstalling the existing or new battery, clean the baking soda from the battery boxes or battery being sure to avoid contact with skin and eyes. Determine source of contamination. NEVER install/reinstall a battery with a cracked or otherwise damaged case.

When securing battery lifting strap to battery, observe polarity markings located on the ends of the battery lifting strap, (+) side to POSITIVE (+) battery post and (-) side to NEGATIVE (-) battery post.

To remove the batteries from the battery boxes, reverse the following steps.

Have the following tools available:

TOOL	QTY	COMMENTS
1/2-INCH (6PT) BOX WRENCH	1	Not Supplied
BATTERY LIFTING STRAP	1	Not Supplied

1. If necessary, remove the battery box(es) from the wheelchair. Refer to one of the following procedures:
 - Removing/Installing Battery Boxes on page 95.
2. Disconnect battery cables. Refer to Disconnecting/Connecting Battery Cables on page 102 for either Group 24 batteries in a single battery box.
3. Secure battery lifting strap to battery terminals/posts.
4. Remove batteries from battery box(es).

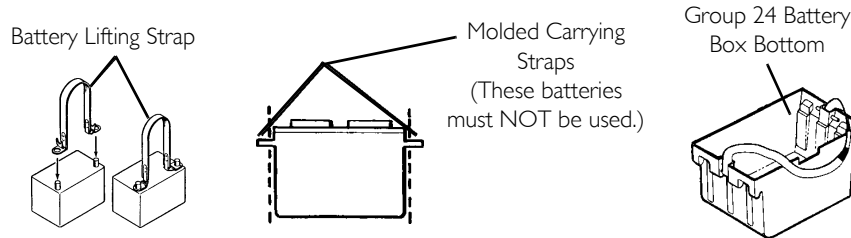

FIGURE 3 Installing/Removing Batteries Into/From Battery Boxes

9.11 Battery Terminals

1. Examine battery clamps and terminals for corrosion.
2. Verify the plastic caps are in place over battery cell holes.
3. Clean terminals and inside battery clamps by using a battery cleaning tool, wire brush, or medium grade sand paper.



Upon completion, areas should be shiny, not dull.

4. Carefully dust off all metal particles.

9 SETUP/MAINTENANCE

9.12 Disconnecting/Connecting Battery Cables

Group 24 Batteries



For this procedure, refer to FIGURE 4 on page 104 and FIGURE 5 on page 105.

Disconnecting



Perform this section on one battery and battery box at a time. Repeat section for other battery box.

1. Lift up on battery box lid to expose underlying cables.
2. Peel back battery terminal caps to expose battery cable ends as follows:
 - A. RED battery terminal cap from RED battery cable.
 - B. BLACK battery terminal cap from BLACK battery cable.
3. Remove the locknut and mounting screw or clamp to disconnect BLACK battery cable from the NEGATIVE(-) battery terminal/post (Detail “A” of FIGURE 5)
4. Remove the locknut and fuse mounting screw or clamp to disconnect RED battery cable from the POSITIVE (+) battery post (Detail “A” of FIGURE 5).

Connecting



Perform this section on one battery and battery box at a time. Repeat section for other battery box.

1. Position battery box top above battery as shown in FIGURE 5.
2. Peel back battery terminal caps to expose battery cable ends as follows:
 - A. RED battery terminal cap from RED battery cable.
 - B. BLACK battery terminal cap from BLACK battery cable.
3. Install the locknut and mounting screw or clamp to connect the BLACK battery cable to the NEGATIVE (-) battery terminal/post (Detail “A” of FIGURE 5).

4. Install the locknut and fuse mounting screw or clamp to connect the RED battery cable to the POSITIVE (+) battery post (Detail "A" of FIGURE 5).
5. Verify battery cables are correctly installed and securely tightened.



Cables will be crossed on one connector battery box top.

6. Reposition terminal caps over battery post(s).
7. Install the battery box top(s).
8. Install the battery box(es) into the wheelchair. Refer to Removing/Installing Battery Boxes on page 95.



New batteries MUST be fully charged before using, otherwise the life of the batteries will be reduced

9. If necessary, charge the batteries. Refer to Charging Batteries on page 67.

9 SETUP/MAINTENANCE

DETAIL "A" - CONNECTING CABLES TO TERMINALS

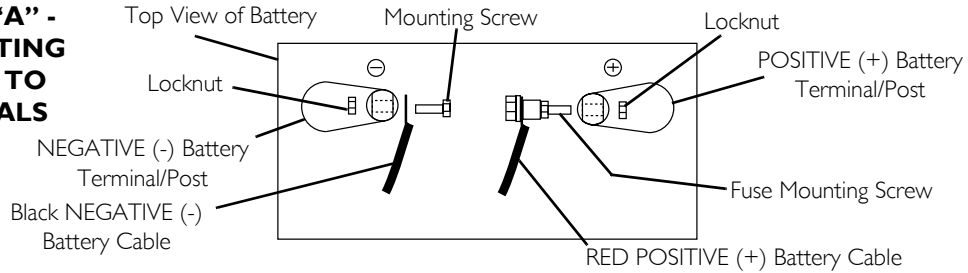

DETAIL "B" - ONE CONNECTOR BATTERY BOX

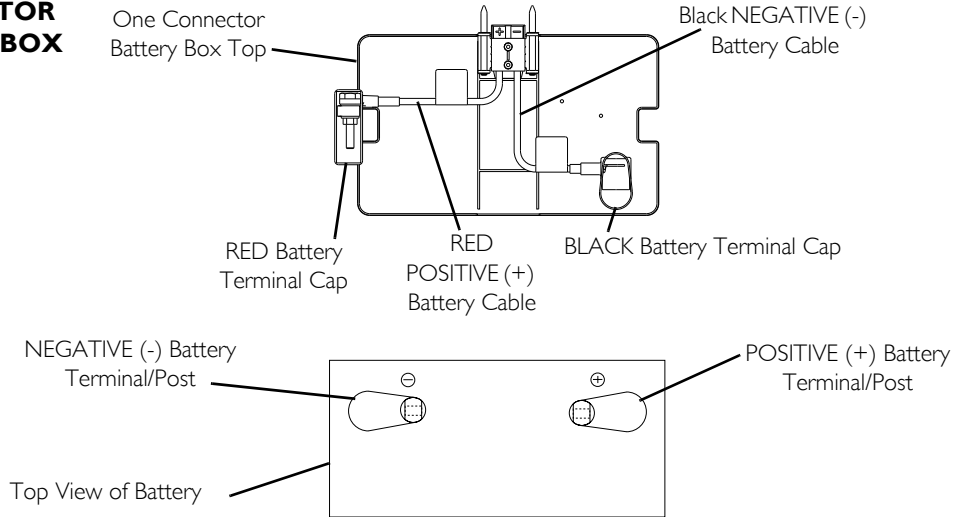
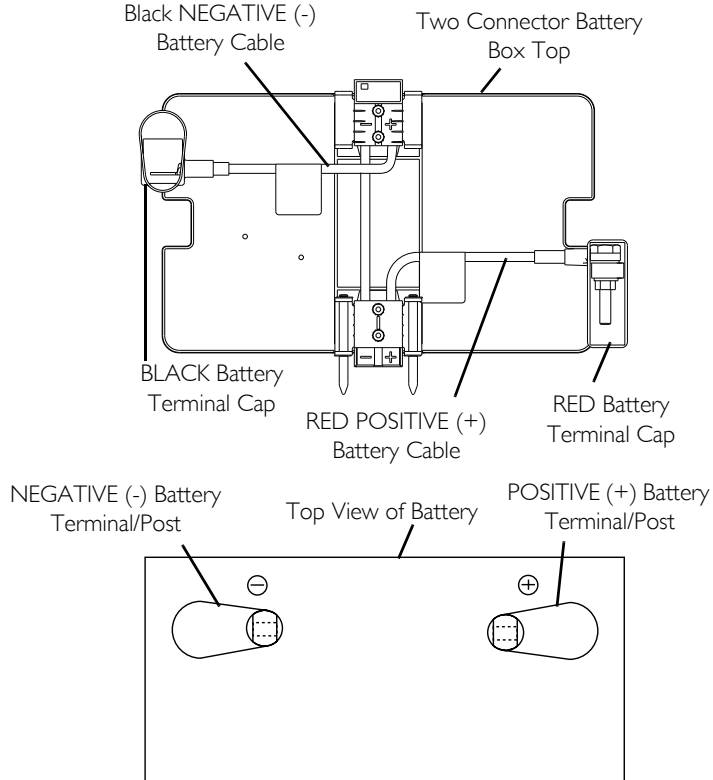

FIGURE 4 Disconnecting/Connecting Battery Cables—Group 24 Batteries

Two Connector Non-Elevate Battery Box



Two Connector Elevate Battery Box

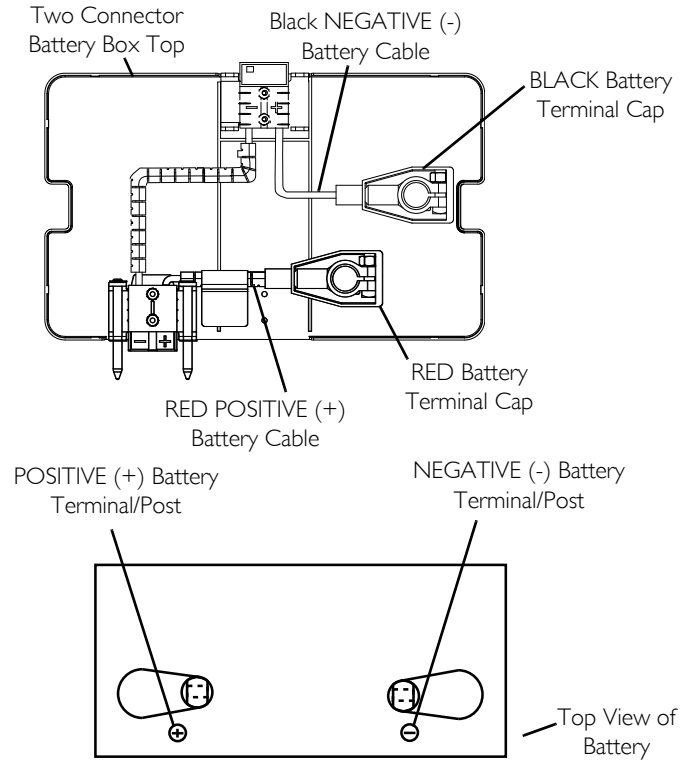

FIGURE 5 Disconnecting/Connecting Battery Cables—Group 24 Batteries

10. If necessary, charge the battery(ies). Refer to Charging Batteries on page 67.

9 SETUP/MAINTENANCE

9.13 Installing Wheel Locks

Wheel Lock Installation Identification

- I. Examine the motor and perform one of the following:
 - Motor assembly Resembles FIGURE 6 - Refer to Installing Wheel Locks for Motor/Gearbox Assemblies on page 107.

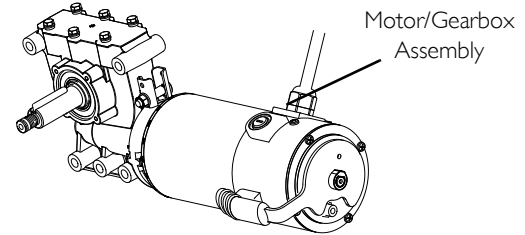

FIGURE 6 Wheel Lock Installation Identification

Installing Wheel Locks for Motor/Gearbox Assemblies



Refer to FIGURE 7 for proper positioning of wheel locks.

1. Determine the appropriate wheel lock mounting position on the wheel lock mounting bracket located on the side frame (FIGURE 7).
2. Using the wheel lock mounting holes shown in FIGURE 7, Position the wheel lock on the outside of the wheel lock mounting bracket of the side frame.
3. Using the two hex screws, washers and locknuts, loosely secure the wheel lock to the wheel lock mounting bracket.
4. Repeat STEPS 1-2 for the opposite wheel lock.
5. Adjust the wheel locks. Refer to Adjusting Wheel Locks on page 108.

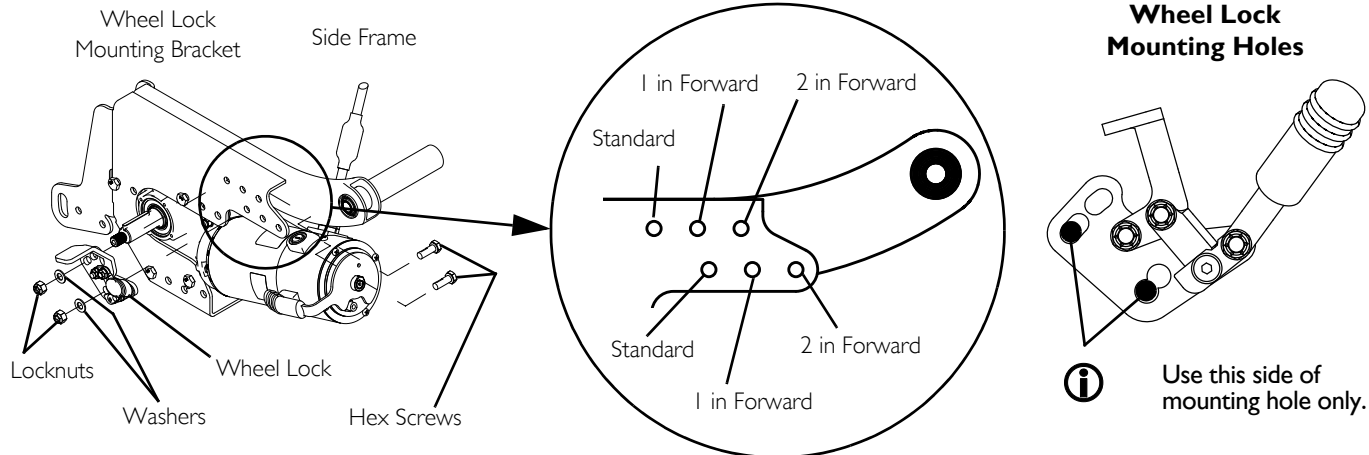

FIGURE 7 Installing Wheel Locks for Motor/Gearbox Assemblies

9 SETUP/MAINTENANCE

9.14 Adjusting Wheel Locks

1. Make sure wheel lock is disengaged from drive wheel.
2. Measure distance between the Wheel Lock Shoe and the Drive Wheel.
3. Loosen the two hex screws securing the wheel lock to the mounting bracket.
4. Slide the wheel lock along the slots until the measurement is between 5/32 and 5/16-inches. Securely tighten mounting screws.
5. Repeat STEPS 1-3 for the opposite wheel lock.
6. Disengage motor lock levers. Refer to [Disengaging/Engaging Motor Lock Levers](#) on page 69.
7. Engage the wheel locks and push against the wheelchair to determine if the wheel locks engage the drive wheels enough to hold the wheelchair.
8. Repeat STEPS 2-7 until the wheel locks engage the drive wheels enough to hold the wheelchair.
9. Engage motor lock levers. Refer to [Disengaging/Engaging Motor Lock Levers](#) on page 69.

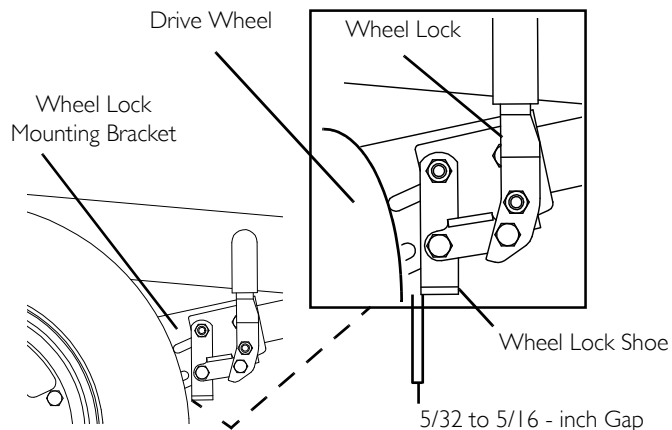

Illustration depicts wheel lock for motor/gearbox assembly.

FIGURE 8 9.14 Adjusting Wheel Locks

9.15 Adjusting Forks

1. Remove the dust cover (not shown) from the caster headtube.
2. To properly tighten caster journal system and guard against flutter, perform the following check:
 - A. Tip back the wheelchair to floor.
 - B. Pivot both forks and casters to top of their arc simultaneously.
 - C. Let casters drop to bottom of arc (wheels should swing once to one-side, then immediately rest in a straight downward position).
 - D. Adjust locknuts according to freedom of caster swing.
3. Test wheelchair for maneuverability.
4. Readjust locknuts if necessary, and repeat STEPS 1-3 until correct.
5. Snap dust cover into the caster headtube.

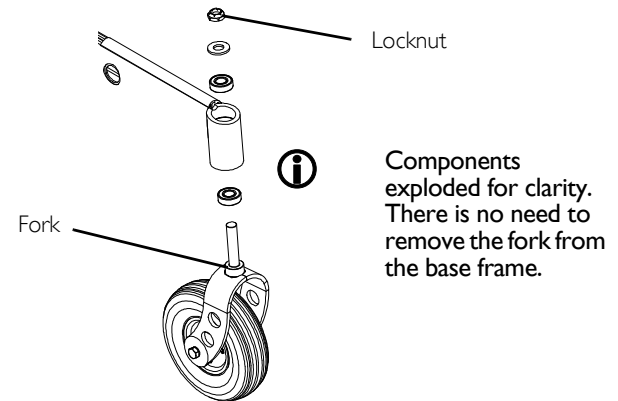

FIGURE 9 Adjusting Forks

9 SETUP/MAINTENANCE

9.16 Adjusting the Extended Active Anti-Tippers



WARNING

Risk of Injury, Damage or Death

Loss of traction or stability may cause injury, damage or death.

- DO NOT operate the wheelchair without antitippers installed. Anti-Tippers must be used at all times.
- Avoid crossing soft surfaces such as wet or soft ground, gravel or mulch. Anti-tippers may not provide the same level of stability.
- Wheelchairs equipped with ventilator tray **MUST** have extended active anti-tippers installed.
- Wheelchairs that are **NOT** equipped with optional ventilator tray **MUST** have either the standard anti-tippers or the optional extended active anti-tippers installed.



For this procedure, refer to FIGURE 10 on page 111.

The extended active anti-tippers are standard when the wheelchair is equipped with a ventilator tray.

The recommended height requirement for the anti-tippers, which is factory preset, is ¼-inch off the ground/floor.

1. Loosen locknuts A, B and C.
2. Lift anti-tipper and place ¼-inch block underneath the wheel.
3. Tighten locknut A upward against the bearing.
4. Tighten locknut B upward against locknut A.
5. Tighten locknut C downward against bearing inside anti-tip assembly.
6. Remove ¼-inch block.
7. Repeat STEPS 1-6 for the remaining anti-tip assembly.
8. Install the dust cover onto each anti-tip assembly.

DETAIL A

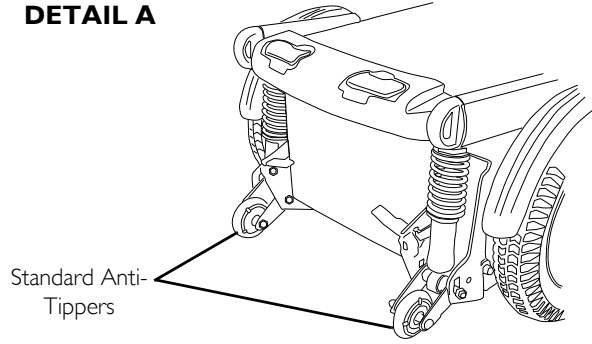

DETAIL B

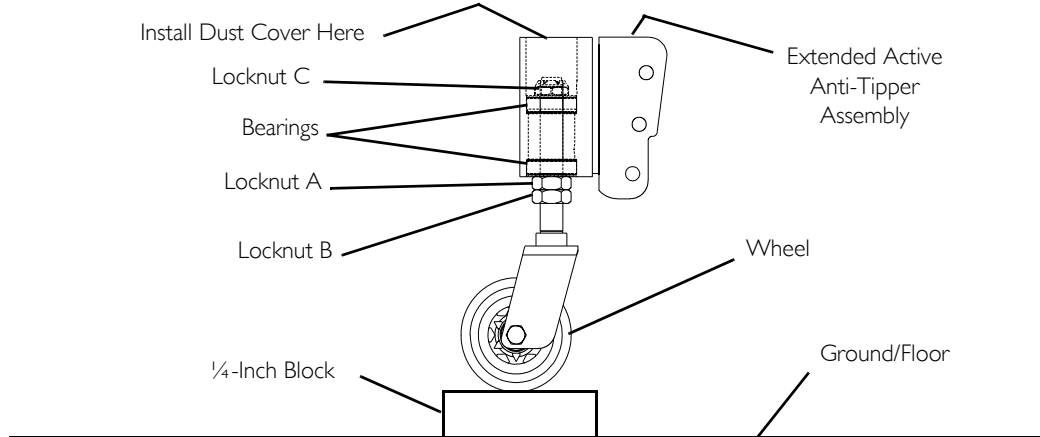
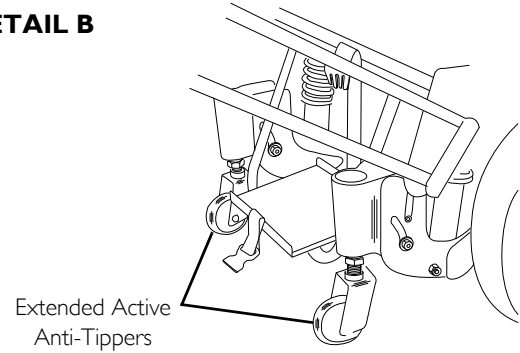

FIGURE 10 Adjusting the Extended Active Anti-Tippers

9 SETUP/MAINTENANCE

9.17 Disconnecting/Connecting the Joysticks



For this procedure, refer to FIGURE 11.
The joystick connector is located at the rear of the seat frame.

SPJ+ Joysticks

Disconnecting

1. Hold the light GREY collar portion of the joystick connector with one hand and the controller connector on the wheelchair in the other and disconnect them by pulling them apart.

Connecting



WARNING

Risk of Injury or Damage

Improper assembly or maintenance may cause injury or damage.

—The joystick connector and controller connector fit together in one way only. **DO NOT** force them together.

1. Hold the light GREY collar portion of the joystick connector with one hand and the controller connector on the wheelchair in the other and align them.

2. Lightly push to engage the joystick connector and the controller connector.

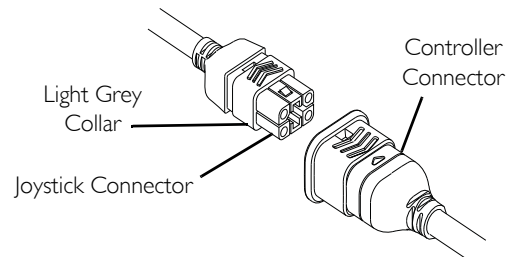

FIGURE 11 Disconnecting/Connecting the Joysticks - SPJ+ Joysticks

CMPJ+ Joysticks

For this procedure, refer to FIGURE 12.

Disconnecting

1. Pull the latch away from the joystick connector.
2. Disconnect the joystick connector from the remaining connectors

Connecting

Ensure the gaskets are installed in the top connector cap and between network connectors.

1. Ensure the latch is pulled away from the network connector.
2. Connect the network connector to the other connectors.
3. Top and Bottom Connectors - Install connector caps onto the network connector.
4. Push the latch in to secure the network connectors and caps.
5. If necessary secure excess cable using tie-wraps.

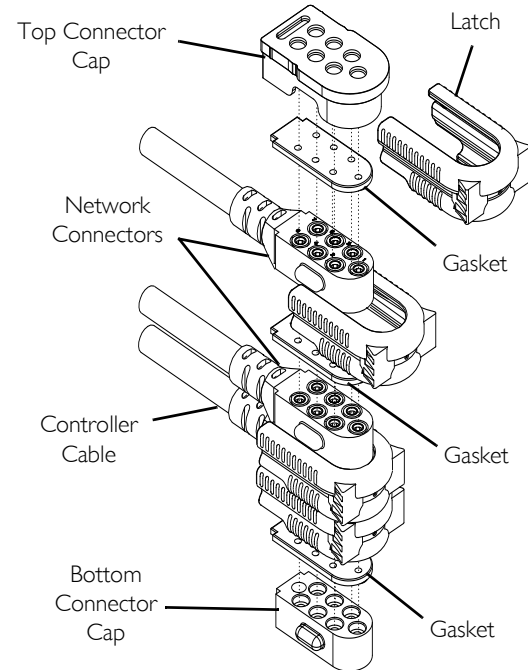

FIGURE 12 Disconnecting/Connecting the Joysticks - CMPJ+ Joysticks

10 Troubleshooting

10.1 Driving Performance

WHEELCHAIR VEERS LEFT/RIGHT	SLUGGISH TURN/ PERFORMANCE	CASTERS FLUTTER	SQUEAKS AND RATTLES	LOOSENESS IN WHEELCHAIR	WHEELCHAIR 3 WHEELS	SOLUTIONS
X	X	X	X			Check for loose stem nuts/bolts, bearings or signs of wear.
X		X	X	X	X	Check for uneven tire wear, bent fork/frame or loose hardware.
X	X	X		X	X	If pneumatic, check tires for correct and equal pressure.

10.2 Electrical







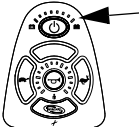

For additional troubleshooting information and explanation of error codes, refer to the individual Electronics Manual supplied with each wheelchair.

SPJ+, SPJ+ w/PSS or SPJ+ w/ACC Joysticks

The joystick information gauge and the service indicator give indications of the type of fault or error detected by the control module. When a fault is detected, the wheelchair may stop and not drive. The LEDs on the information gauge may flash in a particular pattern or the service indicator light will flash. The number or type of flashes indicates the nature of the error. If multiple errors are found, only the first error encountered by the control module will be displayed.

Information Gauge Display Diagnostics

 <p>Information Gauge Display</p>	DESCRIPTION	DEFINITION	COMMENTS
	All LEDs are off.	Power is off.	
	All LEDs are on.	Power is on.	Fewer than three LEDs on implies reduced battery charge.
	Left RED LED is flashing.	Battery charge is low.	The batteries should be charged as soon as possible.
	Left to Right “chase” alternating with steady display.	Joystick is in programming, inhibit and/or charging mode.	The steady LEDs indicate the current state of the battery charge.
	All LEDs are flashing slowly.	Joystick has detected Out-of-Neutral-at-Power-Up mode.	Release the joystick back to Neutral.

10 TROUBLESHOOTING

Service Indicator Light Diagnostics



For this procedure, refer to FIGURE 1.

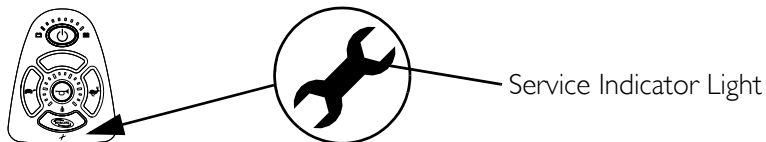

FIGURE 1 Service Indicator Light Diagnostics

NUMBER OF FLASHES	ERROR CODE DESCRIPTION	POSSIBLE SOLUTION
1	User Fault	Release joystick to neutral and try again.
2	Battery Fault	Charge the batteries. Refer to Charging Batteries on page 67. Check that battery cables are connected properly. If necessary, replace batteries. Refer to Disconnecting/Connecting Battery Cables on page 102.
3	Left Motor Fault	Contact Invacare/Dealer for service.
4	Right Motor Fault	Contact Invacare/Dealer for service.
5	Left Park Brake Fault	Ensure brake lever is in the drive position before turning on the wheelchair. Ensure motor cable is plugged into the controller. Contact Invacare/Dealer for service.
6	Right Park Brake Fault	Ensure brake lever is in the drive position before turning on the wheelchair. Ensure motor cable is plugged into the controller. Contact Invacare/Dealer for service.

NUMBER OF FLASHES	ERROR CODE DESCRIPTION	POSSIBLE SOLUTION
7	Remote Fault	Check to make sure joystick is connected properly. Turn Joystick off then on. Contact Invacare/Dealer for service.
8	Controller Fault	Contact Invacare/Dealer for service.
9	Communications Fault	Check joystick cable connections. Check joystick cable and connectors for damage. Contact Invacare/Dealer for service.
10	General Fault	Contact Invacare/Dealer for service.
11	Incompatible or incorrect Remote	Wrong type of remote connected. Contact Invacare/Dealer for service.

CMPJ+, PSR+, PSF+ Joysticks or Displays

SYMPTOM	PROBABLE CAUSE	SOLUTIONS
LEFT BRAKE FAULT or RIGHT BRAKE FAULT displays and wheelchair does not drive.	Motor lock levers disengaged (Error code E9 or E10).	Engage motor lock levers. Refer to <u>Disengaging/Engaging Motor Lock Levers</u> on page 69.
CHARGER PLUGGED IN displays.	Battery charger connected (Error code E28).	Unplug battery charger from the wheelchair. Refer to <u>Charging Batteries</u> on page 67.
BATTERY FAULT displays and the wheelchair does not drive.	Batteries need to be charged (Error code E14).	Charge batteries. Refer to <u>Charging Batteries</u> on page 67. If batteries fail to charge properly, check battery charger or replace batteries. Refer to <u>Replacing Batteries</u> on page 94.
JOYSTICK TIMEOUT displays and the wheelchair does not drive.	Joystick or input device is disconnected (Error code 32).	Turn off power, reconnect the joystick or input device and turn power on.

10 TROUBLESHOOTING

SYMPTOM	PROBABLE CAUSE	SOLUTIONS
JOYSTICK FAULT displays and the wheelchair does not drive.	The joystick or input device is sending a value outside of the reverse, forward, left or right limits (Error codes E01, E02, E03 or E04).	Replace joystick or input device.
NEUTRAL TESTING displays.	The joystick neutral test has failed (Error code E18).	Release the joystick and try to get the joystick back into the center-most position.
BAD JOYSTICK CAL VALUES displays and the wheelchair does not drive.	The joystick calibration values are outside of the expected range (Error code E19).	Recalibrate the joystick (joystick throw procedure).
CTRL NOT CONNECTED	The CMPJ or Display module is not communicating with the control module (Error code E200).	Check the connections between the joystick or display and the controller. Turn the power off and then back on. Replace the controller if necessary.
CTRL COM FAULT displays and the wheelchair drives slowly.	The controller has determined a fault during a previous turn-off process (Error code E41).	Turn the wheelchair off and back on.
MISSING CONFIGURATION displays at power up.	One or more devices have been removed or disconnected from the wheelchair.	Reconnect the device.
ATTENDANT ACTIVE and  displays.	The Proportional or Digital Attendant control is active and can be used to drive the chair.	This is normal behavior.
Batteries draw excessive current when charging.	Battery failure. Electrical malfunction.	Have batteries checked for shorted cell. Replace if necessary. Contact Dealer/Invacare for service.

SYMPTOM	PROBABLE CAUSE	SOLUTIONS
Battery indicator flashes the charge level is low - immediately after recharge.	Battery failure. Malfunctioning battery charger. Electrical malfunction.	Check batteries for shorted cell. Replace if necessary. Contact Dealer/Invacare for Service. Contact Dealer/Invacare for Service.
Battery indicator flashes the charge level is low - too soon after being recharged.	Batteries not charged. Weak batteries.	Have charger checked. Replace batteries if necessary. Refer to Replacing Batteries on page 94.
Motor “chatters” or runs irregular.	Motor/gearbox malfunction.	Stop use of Wheelchair. Contact Dealer/Invacare for Service.
Joystick erratic or does not respond as desired.	Damaged motor coupling. Electrical malfunction. Controller programmed improperly.	Contact Dealer/Invacare for Service. Contact Dealer/Invacare for Service. Contact Dealer/Invacare to have controller reprogrammed.
Wheelchair does not respond to commands.	Electrical malfunction.	Contact Dealer/Invacare for Service.

10 TROUBLESHOOTING

10.3 Checking Battery Charge Level

The following “Do’s” and “Don’ts” are provided for your convenience and safety.

DON'T	DO
Don't perform any installation or maintenance without first reading this manual.	Read and understand this manual and any service information that accompanies a battery and charger before operating the wheelchair.
Don't perform installation or maintenance of batteries in an area that could be damaged by battery spills.	Move the wheelchair to a work area before cleaning terminals, or opening battery box.
Don't make it a habit to discharge batteries to the lowest level.	Recharge as frequently as possible to maintain a high charge level and extend battery life.
Don't use randomly chosen batteries or chargers.	Follow recommendations in this manual when selecting a battery or charger.
Don't put new batteries into service before charging.	Fully charge a new battery before using.
Don't tip or tilt batteries.	Use a carrying strap to remove, move or install a battery.
Don't tap on clamps and terminals with tools.	Push battery clamps on the terminals. Spread clamps wider if necessary.
Don't mismatch your battery and chargers.	Use ONLY a GEL charger for a GEL battery.

II Disposal

II.1 Recycle

This product has been supplied from an environmentally aware manufacturer who complies with the Waste Electrical and Electronic Equipment (WEEE) Directive 2012/19/EC. This product may contain substances that could be harmful to the environment if disposed of in places (landfills) that are not appropriate according to legislation.

Follow local governing ordinances and recycling plans regarding disposal of the wheelchair or components normally used in the operation. The wheelchair does not generate waste or residue in operation.

—DO NOT dispose of the power wheelchair in the normal waste stream.

—Any accessories not part of the wheelchair **MUST** be handled in accordance with the individual product marking for disposal.

—Lead acid batteries are almost entirely recyclable. Discarding these batteries in the trash is considered “improper disposal” and is illegal in most states. Batteries are “hazardous material” and **MUST** be recycled through an approved agency. Contact your dealer or Invacare on proper disposal and recycling of your batteries.

12 Warranty

12.1 Global Limited Warranty (Excluding Canada)

PLEASE NOTE: THE WARRANTY BELOW HAS BEEN DRAFTED TO COMPLY WITH FEDERAL LAW APPLICABLE TO PRODUCTS MANUFACTURED AFTER JULY 4, 1975.

This warranty is extended only to the original purchaser who purchases this product within any country excluding CANADA when new and unused from Invacare or a dealer. This warranty is not extended to any other person or entity and is not transferable or assignable to any subsequent purchaser or owner. Coverage under this warranty will end upon any such subsequent sale or other transfer of title to any other person. For product purchased in Canada, please refer to the Canada Limited Warranty.

This warranty gives you specific legal rights and you may also have other legal rights which vary from state to state.

Invacare warrants the base frame to be free from defects in materials and workmanship for a period of five (5) years from the date of purchase from Invacare or a dealer, with a copy of the seller's invoice required for coverage under this warranty. Invacare warrants the gearless/brushless motors to be free from defects in materials and workmanship for a period of five (5) years from the date of purchase from Invacare or a dealer, with a copy of the seller's invoice required for coverage under this warranty. Invacare warrants all electronics and electrical components (excluding batteries), 2-pole and 4-pole motors, powered seating actuators and gearboxes to be free from defects in materials and workmanship for a period of one (1) year from the date of purchase from Invacare or a dealer, with a copy of the seller's invoice required for coverage under this warranty. Invacare warrants all batteries to be free from defects in materials and workmanship for a period of six (6) months from the date of purchase from Invacare or a dealer, with a copy of the seller's invoice required for coverage under this warranty. Invacare warrants all remaining components (excluding all upholstered materials, padded materials, tires and wheels) to be free from defects in materials and workmanship for a period of one (1) year from the date of purchase from Invacare or a dealer, with a copy of the seller's invoice required for coverage under this warranty. If within such warranty period any such product shall be proven to be defective, such product shall be repaired or replaced, at Invacare's option, with refurbished or new parts. This warranty does not include any labor or shipping charges incurred in replacement part installation or repair of any such product. Product repairs shall not extend this warranty - coverage for repaired product shall end when this limited warranty terminates. Invacare's sole obligation and your exclusive remedy under this warranty shall be limited to such repair and/or replacement.

For warranty service, please contact the dealer from whom you purchased your Invacare product. In the event you do not receive satisfactory warranty service, please write directly to Invacare at the address on the bottom of the back cover. Provide dealer's name address, date of purchase, indicate nature of the defect and, if the product is serialized, indicate the serial number. Do not return products to our factory without our prior consent.

LIMITATIONS AND EXCLUSIONS: THE FOREGOING WARRANTY SHALL NOT APPLY TO SERIAL NUMBERED PRODUCTS IF THE SERIAL NUMBER HAS BEEN REMOVED OR DEFACED, PRODUCTS SUBJECT TO NEGLIGENCE, ACCIDENT, IMPROPER OPERATION, MAINTENANCE OR STORAGE, COMMERCIAL OR INSTITUTIONAL USE, PRODUCTS MODIFIED WITHOUT INVACARE'S EXPRESS WRITTEN CONSENT (INCLUDING, BUT NOT LIMITED TO, MODIFICATION THROUGH THE USE OF UNAUTHORIZED PARTS OR ATTACHMENTS); PRODUCTS DAMAGED BY REASON OF REPAIRS MADE TO ANY COMPONENT WITHOUT THE SPECIFIC CONSENT OF INVACARE, OR TO A PRODUCT DAMAGED BY CIRCUMSTANCES BEYOND INVACARE'S CONTROL, AND SUCH EVALUATION WILL BE SOLELY DETERMINED BY INVACARE. THE WARRANTY SHALL NOT APPLY TO PROBLEMS ARISING FROM NORMAL WEAR AND TEAR OR FAILURE TO ADHERE TO THE PRODUCT INSTRUCTIONS. A CHANGE IN OPERATING NOISE, PARTICULARLY RELATIVE TO MOTORS AND GEARBOXES DOES NOT CONSTITUTE A FAILURE OR DEFECT AND WILL NOT BE REPAIRED; ALL DEVICES WILL EXHIBIT CHANGES IN OPERATING NOISE DUE TO AGING.

THE FOREGOING EXPRESS WARRANTY IS EXCLUSIVE AND IN LIEU OF ANY OTHER WARRANTIES WHATSOEVER, WHETHER EXPRESS OR IMPLIED, INCLUDING THE IMPLIED WARRANTIES OF MERCHANTABILITY AND FITNESS FOR A PARTICULAR PURPOSE, AND THE SOLE REMEDY FOR VIOLATIONS OF ANY WARRANTY WHATSOEVER, SHALL BE LIMITED TO REPAIR OR REPLACEMENT OF THE DEFECTIVE PRODUCT PURSUANT TO THE TERMS CONTAINED HEREIN. THE APPLICATION OF ANY IMPLIED WARRANTY WHATSOEVER SHALL NOT EXTEND BEYOND THE DURATION OF THE EXPRESS WARRANTY PROVIDED HEREIN AND INVACARE SHALL NOT BE LIABLE FOR ANY CONSEQUENTIAL OR INCIDENTAL DAMAGES WHATSOEVER; SOME STATES DO NOT ALLOW THE EXCLUSION OR LIMITATION OF INCIDENTAL OR

**CONSEQUENTIAL DAMAGE, OR LIMITATION OF HOW LONG AN IMPLIED WARRANTY LASTS, SO THE ABOVE EXCLUSION AND LIMITATION MAY NOT BE APPLICABLE.
THIS WARRANTY SHALL BE EXTENDED TO COMPLY WITH STATE/PROVINCIAL LAWS AND REQUIREMENTS.**

12.2 Canada Limited Warranty

This warranty is extended only to the original purchaser who purchases this product within Canada when new and unused from Invacare or a dealer. This warranty is not extended to any other person or entity and is not transferable or assignable to any subsequent purchaser or owner. Coverage under this warranty will end upon any such subsequent sale or other transfer of title to any other person.

This warranty gives you specific legal rights and you may also have other legal rights which vary from state to state.

Invacare warrants the base frame and gearless/brushless motors to be free from defects in materials and workmanship for a period of five (5) years from the date of purchase from Invacare or a dealer, with a copy of the seller's invoice required for coverage under this warranty. Invacare warrants all electronics and electrical components (excluding batteries), powered seating actuators, 4-pole motors and gearboxes to be free from defects in materials and workmanship for a period of two (2) years from the date of purchase from Invacare or a dealer, with a copy of the seller's invoice required for coverage under this warranty. Invacare warrants all batteries to be free from defects in materials and workmanship for a period of six (6) months from the date of purchase from Invacare or a dealer, with a copy of the seller's invoice required for coverage under this warranty. Invacare warrants all remaining components (excluding all upholstered materials, padded materials, tires and wheels) to be free from defects in materials and workmanship for a period of one (1) year from the date of purchase from Invacare or a dealer, with a copy of the seller's invoice required for coverage under this warranty. If within such warranty period any such product shall be proven to be defective, such product shall be repaired or replaced, at Invacare's option, with refurbished or new parts. This warranty does not include any labor or shipping charges incurred in replacement part installation or repair of any such product. Product repairs shall not extend this warranty - coverage for repaired product shall end when this limited warranty terminates. Invacare's sole obligation and your exclusive remedy under this warranty shall be limited to such repair and/or replacement.

For warranty service, please contact the dealer from whom you purchased your Invacare product. In the event you do not receive satisfactory warranty service, please write directly to Invacare at the address on the bottom of the back cover. Provide dealer's name address, date of purchase, indicate nature of the defect and, if the product is serialized, indicate the serial number. Do not return products to our factory without our prior consent.

LIMITATIONS AND EXCLUSIONS: THE FOREGOING WARRANTY SHALL NOT APPLY TO SERIAL NUMBERED PRODUCTS IF THE SERIAL NUMBER HAS BEEN REMOVED OR DEFACED, PRODUCTS SUBJECT TO NEGLIGENCE, ACCIDENT, IMPROPER OPERATION, MAINTENANCE OR STORAGE, COMMERCIAL OR INSTITUTIONAL USE, PRODUCTS MODIFIED WITHOUT INVACARE'S EXPRESS WRITTEN CONSENT (INCLUDING, BUT NOT LIMITED TO, MODIFICATION THROUGH THE USE OF UNAUTHORIZED PARTS OR ATTACHMENTS); PRODUCTS DAMAGED BY REASON OF REPAIRS MADE TO ANY COMPONENT WITHOUT THE SPECIFIC CONSENT OF INVACARE, OR TO A PRODUCT DAMAGED BY CIRCUMSTANCES BEYOND INVACARE'S CONTROL, AND SUCH EVALUATION WILL BE SOLELY DETERMINED BY INVACARE. THE WARRANTY SHALL NOT APPLY TO PROBLEMS ARISING FROM NORMAL WEAR AND TEAR OR FAILURE TO ADHERE TO THE PRODUCT INSTRUCTIONS. A CHANGE IN OPERATING NOISE, PARTICULARLY RELATIVE TO MOTORS AND GEARBOXES DOES NOT CONSTITUTE A FAILURE OR DEFECT AND WILL NOT BE REPAIRED; ALL DEVICES WILL EXHIBIT CHANGES IN OPERATING NOISE DUE TO AGING.

THE FOREGOING EXPRESS WARRANTY IS EXCLUSIVE AND IN LIEU OF ANY OTHER WARRANTIES WHATSOEVER, WHETHER EXPRESS OR IMPLIED, INCLUDING THE IMPLIED WARRANTIES OF MERCHANTABILITY AND FITNESS FOR A PARTICULAR PURPOSE, AND THE SOLE REMEDY FOR VIOLATIONS OF ANY WARRANTY WHATSOEVER, SHALL BE LIMITED TO REPAIR OR REPLACEMENT OF THE DEFECTIVE PRODUCT PURSUANT TO THE TERMS CONTAINED HEREIN. THE APPLICATION OF ANY IMPLIED WARRANTY WHATSOEVER SHALL NOT EXTEND BEYOND THE DURATION OF THE EXPRESS WARRANTY PROVIDED HEREIN AND INVACARE SHALL NOT BE LIABLE FOR ANY CONSEQUENTIAL OR INCIDENTAL DAMAGES WHATSOEVER; SOME STATES DO NOT ALLOW THE EXCLUSION OR LIMITATION OF INCIDENTAL OR CONSEQUENTIAL DAMAGE, OR LIMITATION OF HOW LONG AN IMPLIED WARRANTY LASTS, SO THE ABOVE EXCLUSION AND LIMITATION MAY NOT BE APPLICABLE.

THIS WARRANTY SHALL BE EXTENDED TO COMPLY WITH STATE/PROVINCIAL LAWS AND REQUIREMENTS.