

# The Kennedy Guardian

Fire hydrants have been used in fire protection for over 100 years. A.W.W.A. C502 was developed in 1913 as a standard for the manufacture and use of dry barrel hydrants. Kennedy has established itself as a leader in the industry with manufacturing experience dating back to 1905. Many of the early hydrants are in use today.

Kennedy's most recent design is the Guardian. Based on a simple design, it is easy to install, maintain and repair. The Guardian sets a standard for quality in the industry and meets or exceeds all requirements for A.W.W.A. C502 latest revision, and is UL listed and FM approved.

K81D Meets or exceeds requirements of A.W.W.A. C-502 and is UL listed and FM approved.

K-81A Meets or exceeds requirements of A.W.W.A. C-502.

## Guardian Features

**Fig. K81D**

**One Piece Bonnet**  
Newly designed for easier maintenance.

**Sealed Grease Cavity**  
For easier operation and maintenance.

**Traffic Flange**  
Full 360° adjustment. New Breaking Ring on top for easy replacement and interchangeability on all K-81 models.

**Corrosion Resistant**  
Bronze Drain Valve.

**Bronze to Bronze Seating**  
This standard feature assures easy seat removal.

**Full Cover Bottom Plate**  
Prevents corrosion to the lower stem threads and prevents main valve distortion. Provides a positive stop against the elbow.

**Weather Shield**  
To protect exposed operating area from freezing rain and dirt.

**Thrust Washer**  
For easy turning operation.

**Two O-Rings**  
To protect operating threads from corrosion.

**O-Ring**  
To seal between brass ferrule and stem.

**Nozzle**  
Tamper resistant.

**Breakable Coupling**  
Minimizes damage from traffic accident. New design makes repairs more efficient.

**O-Ring**  
For ease of repair and nozzle facing.

**AWWA**  
**500 psi test pressure**  
**250 psi working pressure**

**ULFM**  
**500 psi test pressure**  
**\*250 psi working pressure**  
  
**\* As of 01-01-2011**

**Easy to install—Even easier to maintain**

- **Tamper resistant** quarter turn hose and steamer nozzles. For those who know how, replacement is easy.
- **Easy to use**, short, simple, inexpensive and lightweight seat removal wrench.
- **Unique pressure-activated** drain valve assures positive shut off. The higher the pressure, the tighter the seal. Automatically compensates for wear due to usage. Does not rely on interference fit.
- **Two sizes available**, 5 1/4" valve opening and 4 1/2" valve opening to best meet your needs.
- **Fully and easily lubricated** operating threads for corrosion protection and ease of operation.
- **The Guardian K-81D Hydrant** meets or exceeds all the latest provisions of AWWA C 502, UL 246 and FM 1510 specifications (options may be limited on UL/FM models)

# Guardian K81D Technical/Dimensional Data (AWWA-UL/FM)

URNS TO OPEN = 15 1/2

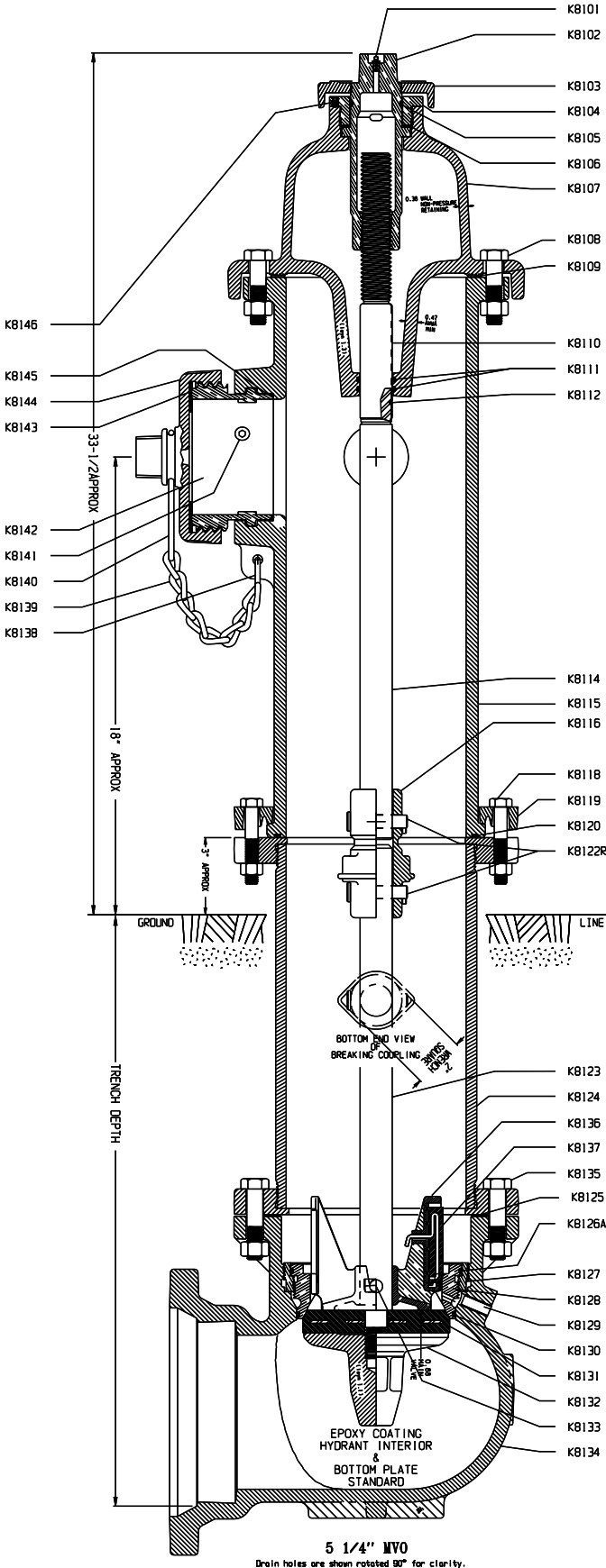

**Figure K81D**

## PARTS LIST

DETAIL	PART	MATERIAL	ASTM SPEC (or as stated)
K8101	ALEMITE FITTING	STAINLESS STEEL	A276 (304)
† K8102	OPERATING STEM NUT	BRONZE	B584 CB4400/AWWA GR A
K8103	DIRT SHIELD	CAST IRON	A126 CLASS B
K8104	STEM LOCK NUT	BRONZE	B584 CB4400/AWWA GR A
† K8105	O-RING	VITON	D2000
† K8106	THRUST WASHER	NYLATRON GS	MIL LP-410
K8107	HYDRANT CAP	CAST IRON	A126 CLASS B
K8108	CAP BOLTS & NUTS	STEEL (ZINC PLATED)	A 307/SAE GR 2
† K8109	CAP GASKET	CLOTH INSERTED RUBBER	D2000
* K8110	STEM FERRULE	NAVAL BRASS	B21-CDA 464
† K8111	O-RING	BUNA-N (SYN. RUBBER)	D2000
* K8112	O-RING	BUNA-N (SYN. RUBBER)	D2000
K8114	UPPER STEM	C.R. STEEL	A108
K8115	UPPER BARREL	CAST IRON	A126 CLASS B
K8116	STEM BREAKING COUPLING	CAST IRON	A126 CLASS B
K8118	BOLTS & NUTS	STEEL (ZINC PLATED)	A 307/SAE GR 2
K8119	BREAKING RING	CAST IRON	A126 CLASS B
K8120	O-RING	BUNA-N (SYN. RUBBER)	D2000
K8122R	COUPLING PINS	STAINLESS STEEL	18-8
K8123	LOWER STEM	C.R. STEEL	A108
K8124	LOWER BARREL	DUCTILE IRON (C.I on request)	ANSI 21.50, 21.51
† K8125	ELBOW GASKET	CELLULOSE FIBER	FED F339477M4
† K8126A	O-RING	BUNA-N (SYN. RUBBER)	D2000
* K8127	SEAT RING INSERT	BRONZE	B584 CB4400/AWWA GR A
† K8128	SEAT RING	BRONZE	B584 CB4400/AWWA GR A
K8129	DRAIN TUBE	NAVAL BRASS	B21-CDA 464
† K8130	O-RING	BUNA-N (SYN. RUBBER)	D2000
† K8131	MAIN VALVE	EPDM W/STEEL INSERT	D2000
K8132	BOTTOM PLATE	CAST IRON	A126 CLASS B
K8133	DRAIN VALVE PIN	STEEL-302/304 STAINLESS	A276 (304)
K8134	ELBOW	DUTILE IRON	A536 GRADE 70-50-5
K8135	ELBOW BOLTS AND NUTS	STEEL-302/304 STAINLESS	ASTM F593-304
K8136	DRAIN VALVE	BRONZE	B584 CB4400/AWWA GR A
† K8137	DRAIN VALVE FACING W/INSERT	BUNA-N W/STAINLESS STEEL	D2000/A276 (304)
K8138	NOZZLE CHAIN 'S' HOOK	STEEL	A108
K8139	NOZZLE CAP CHAIN	STEEL	A108
K8140	NOZZLE CHAIN BAND	STEEL	A108
† K8141	NOZZLE RETAINING SCREW	STAINLESS STEEL	A276 (304)
# K8142	NOZZLE	BRONZE	B584 C83600
†# K8143	NOZZLE CAP GASKET	RUBBER	D2000 TYPE AA
# K8144	NOZZLE CAP	CAST IRON	A126 CLASS B
†# K8145	O-RING	BUNA-N (SYN. RUBBER)	D2000
K8146	ALLEN HEAD SET SCREW	STAINLESS STEEL	A276 (410)
K8147	SEAT REMOVAL WRENCH		
K8148	NOZZLE REMOVAL TOOLS		
† K8149	COLLISION REPAIR KIT		
K8150	GRADE EXTENSION KIT		

\* Denotes that part is available only as part of an assembly.  
 # Must specify type of Nozzle, Hose or Steamer.  
 † Recommended spare parts.

## Accessories

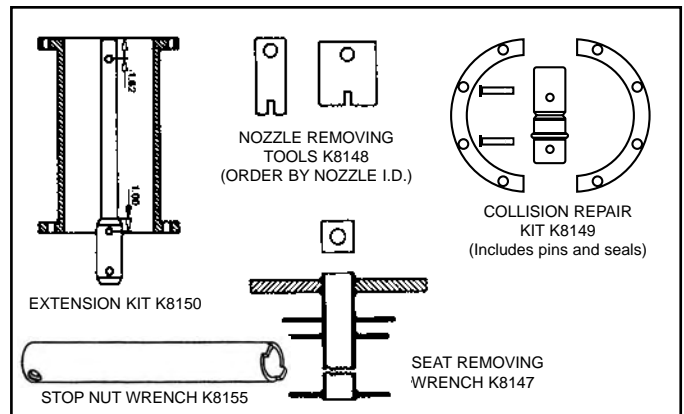

Style	Shoe Size	A
M.J.	4	7 3/4
M.J.	6	8
Flange	4	7 7/8
Flange	6	8 1/8
Tyton	6	9

Tyton ends available only in 5 1/4" Main Valve Hydrants.  
 4" shoe dimensions apply to 4 1/2" Main Valve Hydrants only.

MARKINGS	
FRONT	BACK
YEAR	SIZE
KENNEDY	K.V. MONOGRAM
U.S.A.	KENNEDY
UL / FM	ELMIRA, NY
TYPE	AWWA
	250 CWP

Contact Factory for UL/FM Limitations

# Guardian K-81A with "Storz" Outlet

## Technical/Dimensional Data (AWWA)

URNS TO OPEN = 15 1/2

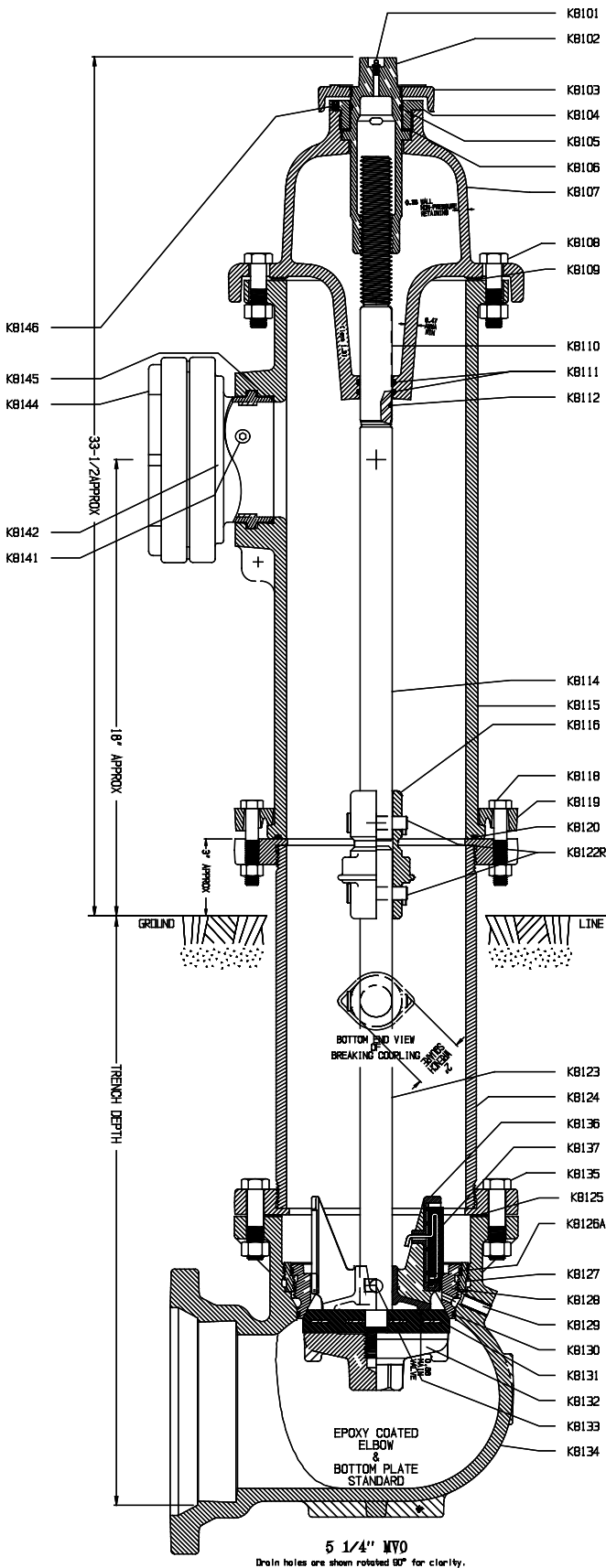

### PARTS LIST

DETAIL	PART	MATERIAL	ASTM SPEC (or as stated)
	KB101	ALEMITE FITTING	STAINLESS STEEL
†	KB102	OPERATING STEM NUT	BRONZE
	KB103	DIRT SHIELD	CAST IRON
	KB104	STEM LOCK NUT	BRONZE
†	KB105	O-RING	VITON
†	KB106	THRUST WASHER	NYLATRON GS
	KB107	HYDRANT CAP	CAST IRON
	KB108	CAP BOLTS & NUTS	STEEL (ZINC PLATED)
†	KB109	CAP GASKET	CLOTH INSERTED RUBBER
*	KB110	STEM FERRULE	NAVAL BRASS
†	KB111	O-RING	BUNA-N (SYN. RUBBER)
*	KB112	O-RING	BUNA-N (SYN. RUBBER)
	KB114	UPPER STEM	C.R. STEEL
	KB115	UPPER BARREL	CAST IRON
	KB116	STEM BREAKING COUPLING	CAST IRON
	KB118	BOLTS & NUTS	STEEL (ZINC PLATED)
	KB119	BREAKING RING	CAST IRON
	KB120	O-RING	BUNA-N (SYN. RUBBER)
	KB122R	COUPLING PINS	STAINLESS STEEL
	KB123	LOWER STEM	C.R. STEEL
	KB124	LOWER BARREL	DUCTILE IRON (or C.I.)
†	KB125	ELBOW GASKET	CELLULOSE FIBER
†	KB126A	O-RING	BUNA-N (SYN. RUBBER)
*	KB127	SEAT RING INSERT	BRONZE
†	KB128	SEAT RING	BRONZE
	KB129	DRAIN TUBE	NAVAL BRASS
†	KB130	O-RING	BUNA-N (SYN. RUBBER)
†	KB131	MAIN VALVE	EPDM W/STEEL INSERT
	KB132	BOTTOM PLATE	CAST IRON
	KB133	DRAIN VALVE PIN	STEEL-302/304 STAINLESS
	KB134	ELBOW	DUCTILE IRON
	KB135	ELBOW BOLTS AND NUTS	STEEL-302/304 STAINLESS
	KB136	DRAIN VALVE	BRONZE
†	KB137	DRAIN VALVE FACING W/INSERT	BUNA-N W/STAINLESS STEEL
	KB138	NOZZLE CHAIN 'S' HOOK	STEEL
	KB139	NOZZLE CAP CHAIN	STEEL
	KB140	NOZZLE CHAIN BAND	STEEL
†	KB141	NOZZLE RETAINING SCREW	STAINLESS STEEL
~#	KB142	NOZZLEW/STORZ DEVICE	BRONZE & AIRCRAFT ALUM
~*#	KB143	NOZZLE CAP GASKET (INTEGRAL)	RUBBER
~*#	KB144	NOZZLE CAP	AIRCRAFT ALUMINUM
†#	KB145	O-RING	BUNA-N (SYN. RUBBER)
	KB146	ALLEN HEAD SET SCREW	STAINLESS STEEL
	KB147	SEAT REMOVAL WRENCH	
	KB148	NOZZLE REMOVAL TOOLS	
†	KB149	COLLISION REPAIR KIT	
	KB150	GRADE EXTENSION KIT	

\*Denotes that part is available only as part of an assembly.  
 #Must specify type of Nozzle, Hose or Steamer.  
 †Recommended spare parts.  
 ~#Special for this Customer Only.

### "Storz" Features

- No more time consuming threading and tightening
- Only 1/4 turn connects hose to hydrant
- Alleviates confusion if multiple steamer threads are used in your area
- Available in 4" and 5" connections

Style	Shoe Size	A
M.J.	4	7 3/4
M.J.	6	8
Flange	4	7 7/8
Flange	6	8 1/8
Tyton	6	9

Tyton ends available only in 5 1/4" Main Valve Hydrants.  
 4" shoe dimensions apply to 4 1/2" Main Valve Hydrants only.

# Tamper-Resistant Guardian Shield Lock Nut

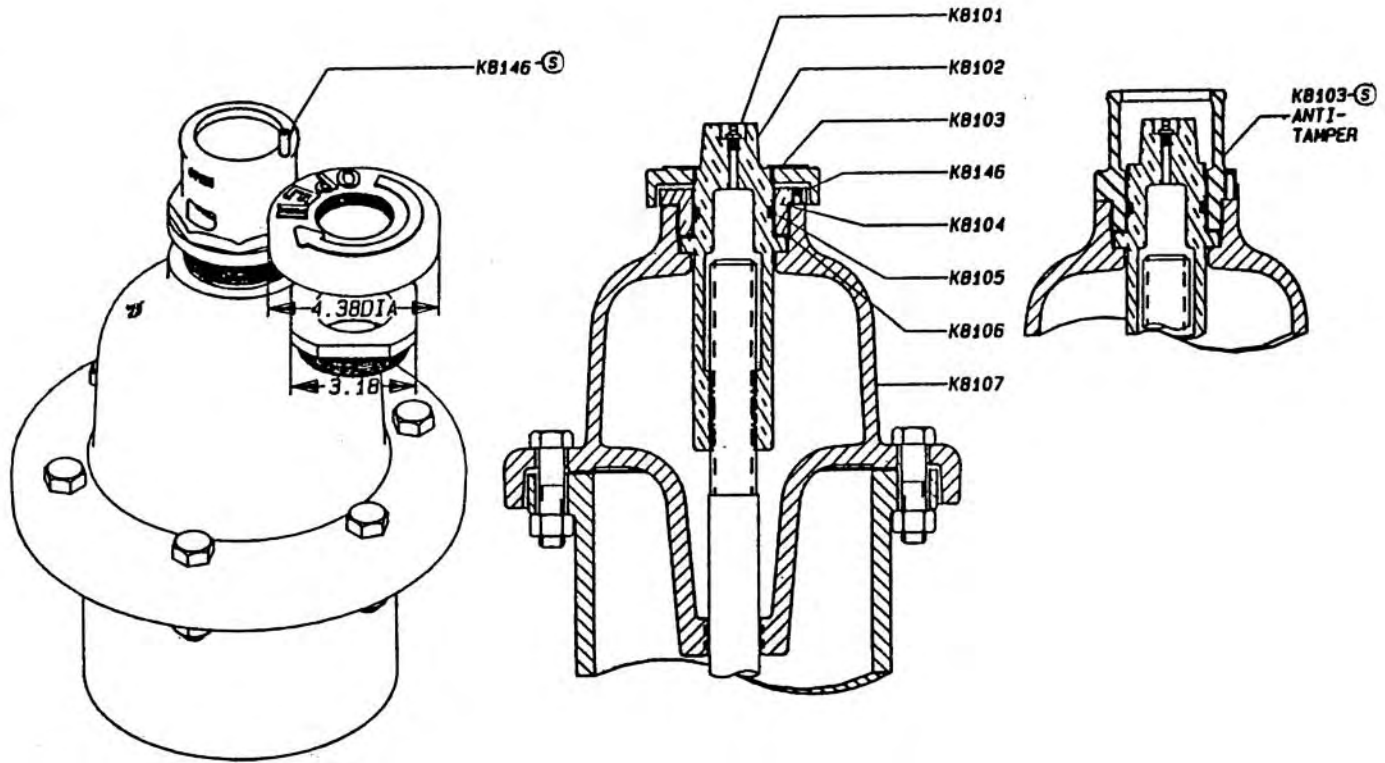

## Parts List

DETAIL	PART	MATERIAL	ASTM SPEC		PART CODE
K8101	ALEMITE FITTING	STAINLESS STEEL	A276 (304)	-	4-41670P
K8102	OPERATING STEM NUT	BRONZE	B 62 (CDA 836)	-	-VARIES
K8103	DIRT SHIELD	CAST IRON	A 126 CLASS B	OPEN LEFT	3212132
				OPEN RIGHT	3212133
K8104	STEM LOCK NUT	BRONZE	B 62 (CDA 836)	-	3-185944
K8103 <sup>Ⓢ</sup>	ANTI TAMPER LOCK NUT	DUCTILE IRON	A536	OPEN LEFT	3212114
				OPEN RIGHT	3212112
K8105	O-RING	BUNA-N	D 735	-	442905P
K8106	THRUST WASHER	NYLATRON GS	(TO MIL LP-410)	-	445843P
K8107	HYDRANT CAP OR DOME	CAST IRON	A 126 CLASS B	- 5 1/4"	-3185962
K8146	ALLEN HEAD SET SCREW	STAINLESS STEEL	A 276	-	4-44438P
K8146 <sup>Ⓢ</sup>	ALLEN HEAD SET SCREW	STAINLESS STEEL	A 276	-	4-44449P

## Instructions

1. Remove the cast iron shield, K8103. Use a large (6") pipe wrench to remove the dirt shield & a hydrant wrench to prevent the hydrant from being opened.
2. Remove the allen head, cone point set screw K8146. Use a 1/8" allen wrench.
3. Remove the stem hold down or lock nut K8104. Use a large (4") monkey or crescent wrench. Note that the hold down nut has a left hand thread & is turned clockwise to remove it.
4. Inspect the thrust bearing, K8106. If necessary replace it.
5. Inspect the anti tamper combination. Hold down nut/dirt shield K8103<sup>Ⓢ</sup> to be certain that the arrow points in the correct direction.
6. Start the anti tamper combination hold down nut/dirt shield into the dome by hand. (It may be difficult to force it over the 'O'-ring.) And then tighten it firmly. (i.e. 200 lb-ft).
7. Replace the set screw and tighten the screw tight (i.e. 80 lb-ft).
8. If possible operate the hydrant to check the installation.

# Ordering Information

## Guardian Hydrant

When ordering, indicate the following:

1. Size of main valve opening.
2. Quantity and threading details of hose nozzles.
3. Threading details of steamer nozzle.
4. Size and type of inlet connection (mechanical joint, flanged, asbestos-cement, bell, or tyton).
5. Depth of bury (from bottom of pipe to ground line).

## Parts

When ordering parts, indicate the following:

1. Part number
2. Part description
3. Type of hydrant
4. Size of main valve opening

**ELBOW** – We must have the size and type of connection to main.

**OPERATING STEM NUT** – Give direction to open (cast on cap) and size and shape of operating nut. 4-sided nut, give flat to flat dimension. 5-sided nut, give point to opposite flat dimension. 6-sided nut, give flat to flat dimension to eliminate any doubt as to where the measurement was taken.\*

Note: Dual rated hydrants are UL/FM approved for 1½P and 1¼" sq. nut sizes.

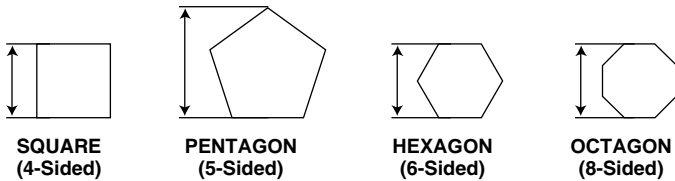

**CAP** – Give direction the hydrant opens. This is indicated by an arrow cast on the cap. Indicate the direction the arrow points.

**NOZZLE CAP GASKET** – Indicate size of nozzle and whether hose or steamer.

**NOZZLE** – Give exact threading details, outside (major) diameter, pitch diameter, root (minor) diameter and exact number of threads per inch (TPI) or send in a gauge or sample in good condition.

6. Color (National standard yellow will be furnished unless otherwise indicated).
7. Size and shape of operating nut.
8. Direction to open.
9. Regular or Bronze Lined (for Mathews-Guardian Insert only).

## Estimated Weights

Main Valve Opening	K-81A	Depth of Trench										
		2'6"	3'0"	3'6"	4'0"	4'6"	5'0"	5'6"	6'0"	6'6"	7'0"	
	K-81A	4½"	336	351	366	381	396	411	426	441	456	534
		5¼"	380	409	427	444	460	480	502	523	542	560
	K-81AW	3-way configuration with M.J. shoe less accessories										
		4"	281	297	316	333	350	365	381	396	414	429
	K-81AW	4½"	278	295	313	330	347	362	378	393	411	426
		5¼"	328	335	355	375	395	415	430	445	468	489
3-way configuration												

**NOZZLE CAP CHAIN** – Tell us the nozzle type, hose or steamer.

**NOZZLE CAP** – Exact threading and nut size and shape.

**UPPER BARREL** – Furnish all information cast on the barrel and the number of hose and steamer connections.

**STEM** – Furnish the direction the hydrant opens as cast on the cap and furnish the depth of trench (distance from groundline to bottom of connecting pipe). If the stem can be measured, complete overall dimensions including diameter will help. The diameter should always be measured on the smooth (unthreaded) portion.\*

**LOWER BARREL** – Furnish depth of trench (distance from groundline to bottom of connecting pipe) or dimension from flange face to flange face (overall). The outside and inside diameters are also a help.

**SEAT RING** – As with all parts you order we must have size of main valve opening and type of hydrant. This is cast on the upper barrel.

## National Standard Hose Coupling Thread Specifications (NST)

<b>A. Nominal inside diameter</b>		2½"	3"	3½"	4"	4½"
<b>Number of threads per inch</b>		7½	6	6	4	4
<b>B. Major diameter nozzle thread</b>	<b>Max.</b>	3.0686	3.6239	4.2439	5.0109	5.7609
	<b>Min.</b>	3.0366	3.5879	4.2079	4.9609	5.7109
<b>C. Pitch diameter nozzle thread</b>	<b>Max.</b>	2.9820	3.5156	4.1356	4.8485	5.5985
	<b>Min.</b>	2.9660	3.4976	4.1176	4.8235	5.5735
<b>D. Minor diameter nozzle thread</b>	<b>Max.</b>	2.8954	3.4073	4.0273	4.6861	5.4361
<b>E. Diameter pilot nozzle</b>		2.8500	3.3540	3.9730	4.6100	5.3570
<b>F. Length of thread – nozzle</b>		1"	1⅛"	1⅛"	1¼"	1¼"
<b>G. Face to start of second turn</b>		¼"	5/16"	5/16"	7/16"	7/16"
<b>H. Major diameter coupling thread</b>	<b>Min.</b>	3.0836	3.6389	4.2639	5.0359	5.7859
<b>I. Pitch diameter coupling thread</b>	<b>Max.</b>	3.0130	3.5486	4.1736	4.8985	5.6485
	<b>Min.</b>	2.9970	3.5306	4.1556	4.8735	5.6235
<b>J. Minor diameter coupling thread</b>	<b>Max.</b>	2.9424	3.4583	4.0833	4.7611	5.5111
	<b>Min.</b>	2.9104	3.4223	4.0473	4.7111	5.4611
<b>K. Depth of coupling</b>		5/16"	1⅛"	1⅛"	1¾"	1¾"

Also available: Figure 109 Hose Gate Valve (2½").

# Kennedy Guardian Monitor Hydrant

5 1/4" K81AM  
AWWA  
NON-TRAFFIC  
MODEL

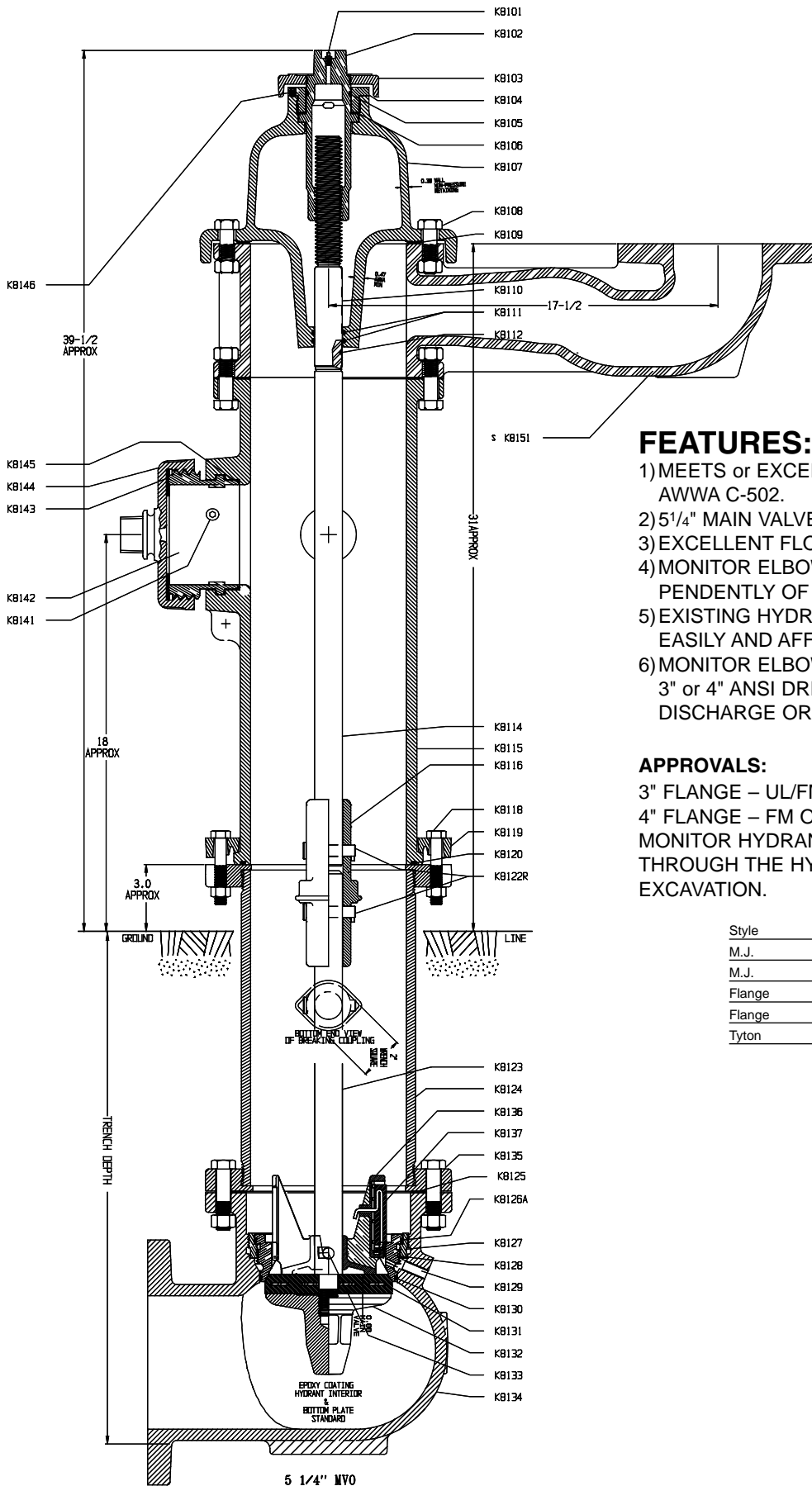

## FEATURES:

- 1) MEETS or EXCEEDS ALL REQUIREMENTS OF AWWA C-502.
- 2) 5 1/4" MAIN VALVE OPENING.
- 3) EXCELLENT FLOW CHARACTERISTICS.
- 4) MONITOR ELBOW CAN BE POSITIONED INDEPENDENTLY OF THE UPPER BARREL.
- 5) EXISTING HYDRANTS CAN BE RETROFITTED EASILY AND AFFORDABLY.
- 6) MONITOR ELBOW IS AVAILABLE WITH EITHER 3" or 4" ANSI DRILLING WITH THE SAME LARGE DISCHARGE ORIFICE.

## APPROVALS:

- 3" FLANGE – UL/FM APPROVED
  - 4" FLANGE – FM ONLY
- MONITOR HYDRANT CAN BE MAINTAINED THROUGH THE HYDRANT CAP WITHOUT EXCAVATION.

Style	Shoe Size	A
M.J.	4	7 3/4
M.J.	6	8
Flange	4	7 7/8
Flange	6	8 1/8
Tyton	6	9

5 1/4" MVO  
Drain holes are shown rotated 90° for clarity.

# 5 1/4" K81AM AWWA Guardian Monitor Hydrant

## PARTS LIST

### Options:

#### Upper Barrel Configurations

- 1 Steamer & 2 Hose Nozzles
- 2 Hose Nozzles
- 2 Steamer Nozzles
- 1 Steamer & 3 Hose Nozzles

#### Handwheel Operation – 16" ø

#### Inlet Connections

- 6" Mechanical Joint, Flanged, Push-on or Ring Tite Elbows
- 6" ANSI Straight Shoe
- 6" 250# Raised Face Elbow
- 8" Mechanical Joint or Flanged Elbow

#### 2 1/2" Size

#### Independent Hose Gate Valves

- Bolt-on/Figure 109XNS
- Screw-on/Figure 109XMN

#### Salt Water Protection

- Fusion Bonded Coatings
- Stainless Steel Stems & Fasteners

#### Operating Details

- "Open" Clockwise or Counter Clockwise
- Any Size & Shape of Operating Nuts
- Any Nozzle Outlet Thread(s)

DETAIL	PART	MATERIAL	ASTM SPEC (or as stated)
	K8101	ALEMITE FITTING	STAINLESS STEEL
†	K8102	OPERATING STEM NUT	BRONZE
	K8103	DIRT SHIELD	CAST IRON
	K8104	STEM LOCK NUT	BRONZE
†	K8105	O-RING	BUNA-N (SYN. RUBBER)
†	K8106	THRUST WASHER	NYLATRON GS
	K8107	HYDRANT CAP	CAST IRON
	K8108	CAP BOLTS & NUTS	STEEL (ZINC PLATED)
†	K8109	CAP GASKET	CLOTH INSERTED RUBBER
*	K8110	STEM FERRULE	NAVAL BRASS
†	K8111	O-RING	BUNA-N (SYN. RUBBER)
*	K8112	O-RING	BUNA-N (SYN. RUBBER)
	K8114	UPPER STEM	H.R. STEEL
	K8115	UPPER BARREL	CAST IRON
	K8116	STEM BREAKING COUPLING	CAST IRON
	K8118	BOLTS & NUTS	STEEL (ZINC PLATED)
	K8119	BREAKING RING	CAST IRON
	K8120	O-RING	BUNA-N (SYN. RUBBER)
	K8122	CLEVIS PINS	STAINLESS STEEL (18-8)
	K8123	LOWER STEM	H.R. STEEL
	K8124	LOWER BARREL	DUCTILE IRON (or C.I.)
†	K8125	ELBOW GASKET	CELLULOSE FIBER
†	K8126A	O-RING	BUNA-N (SYN. RUBBER)
*	K8127	SEAT RING INSERT	BRONZE
†	K8128	SEAT RING	BRONZE
	K8129	DRAIN TUBE	NAVAL BRASS
†	K8130	O-RING	BUNA-N (SYN. RUBBER)
†	K8131	MAIN VALVE	NEOPRENE W/STL. INSERT
	K8132	BOTTOM PLATE	CAST IRON
	K8133	DRAIN VALVE PIN	STEEL-STAINLESS
	K8134	ELBOW	DUCTILE IRON
	K8135	ELBOW BOLTS AND NUTS	STAINLESS STEEL
†	K8136	DRAIN VALVE	BRONZE
	K8137	DRAIN VALVE FACING W/INSERT	BUNA-N W/STAINLESS STEEL
*	K8139	NOZZLE CAP CHAIN	STEEL
*	K8140	NOZZLE CHAIN BAND	STEEL
†	K8141	NOZZLE RETAINING SCREW	STAINLESS STEEL
#	K8142	NOZZLE	BRONZE
#	K8143	NOZZLE CAP GASKET	NEOPRENE RUBBER
#	K8144	NOZZLE CAP	CAST IRON
†#	K8145	O-RING	BUNA-N (SYN. RUBBER)
	K8146	ALLEN HEAD SET SCREW	STAINLESS STEEL
†	K8147	SEAT REMOVAL WRENCH	
	K8148	NOZZLE REMOVAL TOOLS	
†	K8149	COLLISION REPAIR KIT	
	K8150	GRADE EXTENSION KIT	
	K8151	MONITOR ELBOW-SPECIAL	

\* = Denotes that part is available only as part of an assembly.  
 # = Must specify type of Nozzle, Hose or Steamer.  
 † Recommended spare parts.

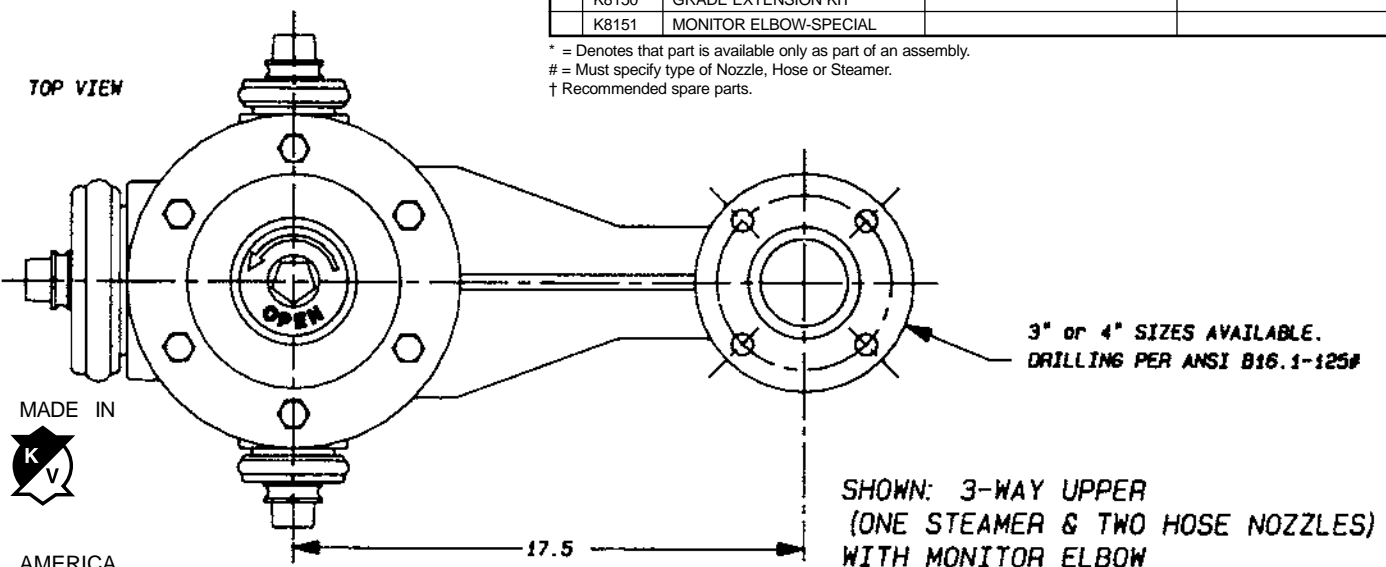

# Iron Hose Gate Valves

## Working pressures:

2 1/2" Cold Water, Non-Shock 250 psi.

- Non-Rising Stem
- Bronze Mounted
- Rubber Seat

HYDROSTATIC TEST PRESSURE: 2 1/2" — Seat & Shell — 500 psi.

PART NO.	NAME OF PART	MATERIAL	ASTM SPEC.
1	HEX NUT	STEEL	A-108 C-1018
2	HANDWHEEL	MALL. IRON	A-47
3	STUFFING BOX	BRONZE	B-62
4	HX. HD. SCR. & NUT	STEEL	A-108 C-1018
5	"O" RINGS	SYN. RBR.	D-735
6	CAP BUSHING	BRONZE	B-135 ALLOY A
7	SEAT & GSKT. FLG.	NEOPRENE	—
8	NOZZLE	BRONZE	B-62
9	CAP	CAST IRON	A-126 GR. B
10	STEM	MANG. BRZ.	B-132 ALLOY A
11	GASKET	GARLOCK 1591	—
12	BODY	CAST IRON	A-126 GR. B
13	DISC	BRONZE	B-62
14	PIN	BRZ. ROD	B-16

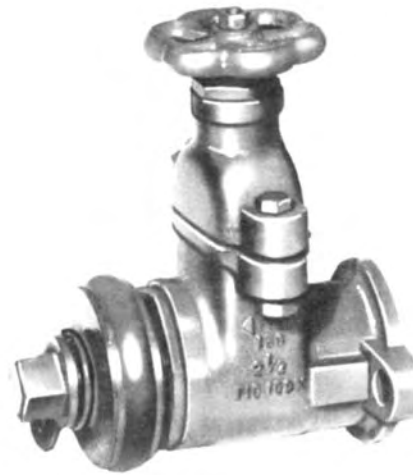
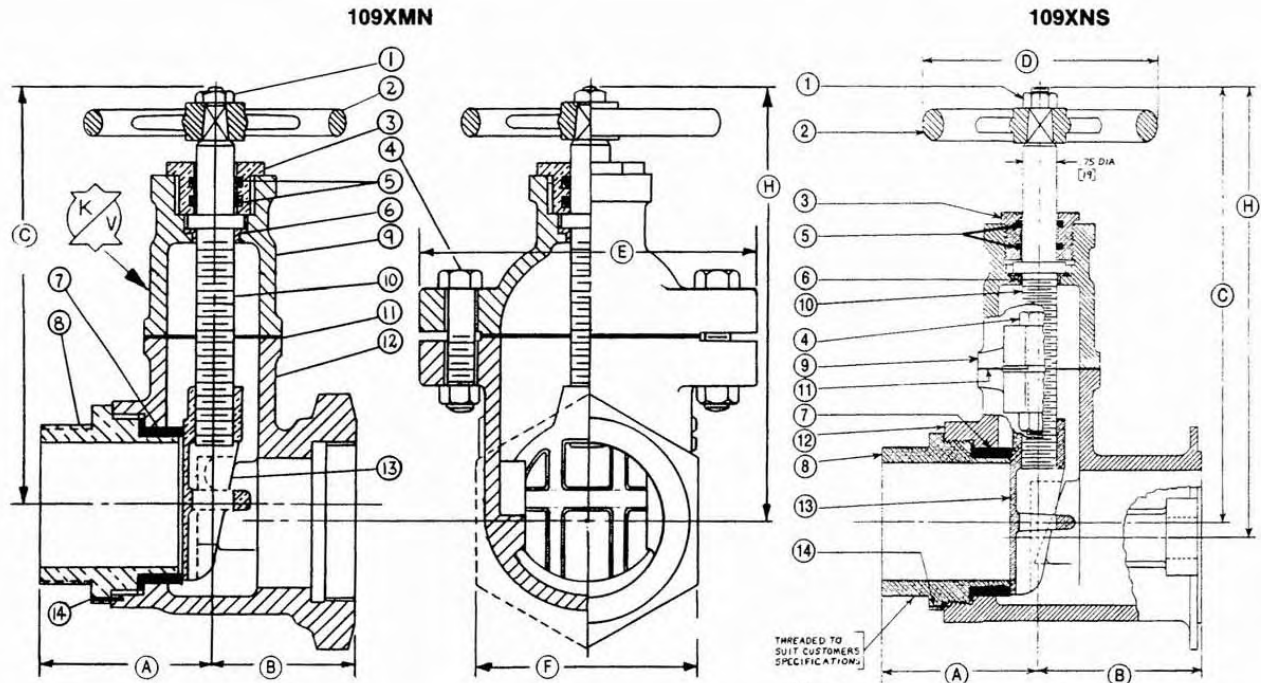

FIG. 109XNS SHOWN

FIG. 109XMN (Screwed ends also)



MODEL	A	B	C	D	E	F	G	H	WT
109XNS	3 5/16"	3 1/2"	8 5/16"	4 3/8"	6 1/2"	5 5/8"	7/8"	8 5/8"	29
109XMN	3 5/16"	2 3/4"	8 5/16"	4 3/8"	6 1/2"	4 1/4"	N/A	8 5/8"	28

**CAP MARKING**  
KV LOGO

**BODY MARKING**  
FRONT  
◀ FM ▶  
250  
2 1/2  
FIG. 109-X  
BACK  
UL  
LISTED  
FIRE  
HOSE VALVE  
885H

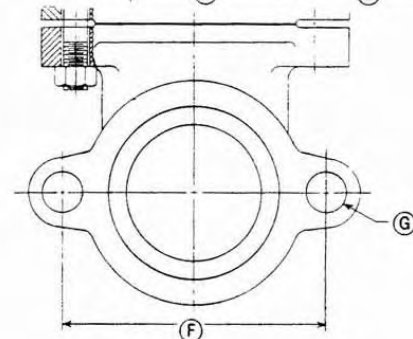

Updated 02/14/12



IT IS PREFERABLE TO BE ABLE TO TURN THE WATER PRESSURE ON AND OFF IF THE WATER PRESSURE IS LOW IT IS POSSIBLE THAT THE HYDRANT WILL BE OPENED WHEN REMOVING THE UPPER

1. Make certain that the hydrant is closed. The water may remain on but see above note.
2. Remove the eight 1/2-UNC bolts & nuts that retain the breaking rings.
3. Turn the Operating Nut in the opening direction until the threaded stem disengages from the Operating Nut. (This will lift the Upper pipe assembly and dome from the stem.)
4. Lift the complete hydrant upper stand-pipe assembly and dome from the stem.
5. Lift this assembly straight up about 12" to avoid damaging the O-Rings that seal the stem and remove the complete upper assembly.
6. Disengage the Lower Stem from the Upper Stem. Remove the lower Clevis/Spring Pin that retains the Lower Stem to the Breaking Coupling.
7. Wire brush the exposed flange of the lower stand-pipe flange until all dirt and built up rust is removed.
8. Wire brush the end of the Lower Stem and attach the Extension Stem Coupling to the Lower Stem exactly as illustrated below.
9. Attach the Upper Stem to the Extension Stem in exactly the same way that it previously was attached to the Lower Stem.
10. Place the Gasket for the Extension Spool on the exposed flange of the Lower Stand-Pipe.
11. Retain the Extension Spool on the Lower Stand-Pipe and align the bolt holes.
12. Insert the bolts provided in the holes. Start the nuts provided on the bolts. Tighten the bolts wrist tight only then tighten them securely (70 ft-lb), proceeding in a side to side pattern that assures that the pressure on the gasket is uniform.
13. Carefully lift the complete upper assembly up above the Upper Stem and lower it on to the Upper Stem taking care not to cut the O-Rings in the Dome.
14. Turn the Operating Nut in the closed direction until the bottom of the Stand Pipe just touches the flange.
15. Align the hydrant and replace the breaking rings in the original position.
16. Replace the bolts in the breaking rings and close the hydrant tightly.
17. Start the nuts on the bolts and tighten the bolts per step 11 except that the torque should be 40 ft-lb.

K81

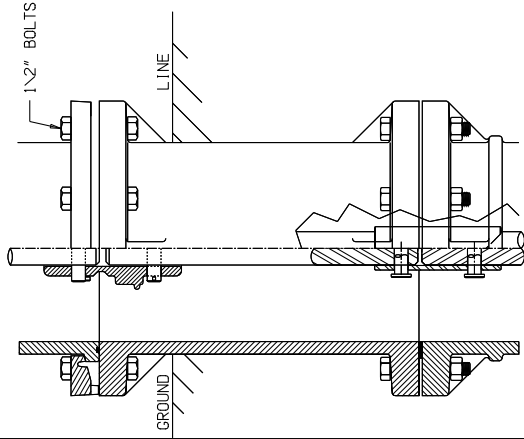

SPOOL INSTALLATION

K-81 EXTENSION STEM INSTALLATION

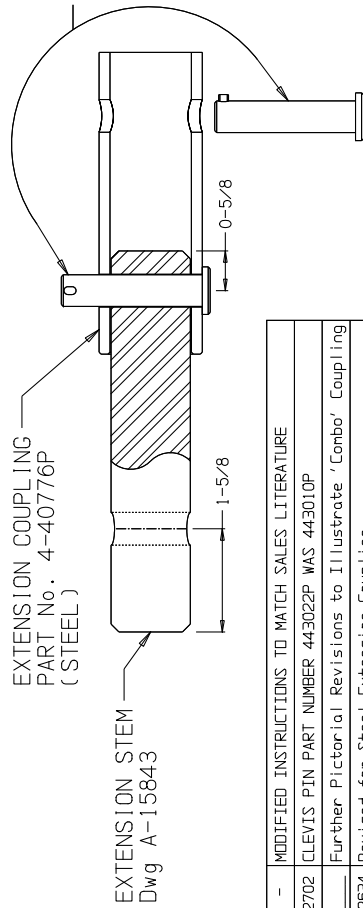

- TOOLS REQUIRED
1. WIRE SCRATCH BRUSH
  2. HAMMER
  3. (2)-8" ADJUSTABLE WRENCH(S)
  4. PLIERS
  5. DRIFT (FOR HOLE ALIGNMENT)

**KENNEDY VALVE**  
ELMIRA, N.Y. 14901

STEM EXTENSION ASSEMBLY  
K 81 A/D HYDRANT  
STEEL EXTENSION COUPLING

PART CODE #  
A 4-00817P

DWG NO.  
**16143**

Revision 08

NO	Date	ECN	REVISION
8	09/08	-	MODIFIED INSTRUCTIONS TO MATCH SALES LITERATURE
7	07/06	2702	CLEVIS PIN PART NUMBER 443022P WAS 443010P
6	08/01	-	Further Pictorial Revisions to Illustrate 'Combo' Coupling
5	10/00	2634	Revised for Steel Extension Coupling
4	10/99	BMLC 0113	No Actual Change to Dwg - Rev Level Chg'd Due Unreleased/Incorrect Dwg Marked 'Rev 3' in System
3	7/98	-	Revise to show Post 1996 Clevis Pins with Letter Pins
2	8/93	N/A	Keep Old Previous Groove Ends with Half in Lip
1	6/30	2396	Remove Cast in Ground Tube Bead CREATED KB1A (ONLY) EXTENSION

NOTE:  
1. ALL K81 STEMS  
1.250 DIA

FILE PATH  
DRAFT\HY

DRAWN

ISSUED  
6-16-90

- Hydrants shall be UL listed and FM approved.
- Hydrants shall conform to A.W.W.A. Standard C-502 latest revision and as specified herein.
- Hydrants shall be of the compression type, closing with line pressure.
- Hydrants shall be of the traffic model breakaway type.
- Hydrant cap and stuffing box shall be of a unitized, one piece design creating a water tight cavity without the use of gaskets. The combination of 3 O-Rings to a crimped brass ferrule around the stem shall seal the cavity from contact with water. An alemite fitting shall be supplied for periodic lubrication of the operating threads with grease.
- Operating nut shall be of one piece bronze construction.
- A dirt shield shall be provided to protect the operating mechanism from grit buildup and corrosion due to moisture.
- A thrust washer shall be supplied between the operating nut and stem lock nut to facilitate operation.
- Nozzles shall be of the tamper resistant, 1/4 turn type with O-ring seals and stainless steel retaining screws.
- An O-ring shall be provided to seal between the upper and lower barrels.
- The main valve shall be of synthetic rubber reinforced with steel.
- The seat shall be of a bronze ring threaded to a bronze insert in the hydrant shoe, with O-Rings to seal the drainway and barrel from leakage of water in the shoe.
- Hydrant drain valve shall momentarily force flush with each operation. Drainway shall be of bronze. Drain valve facing shall be of synthetic rubber with a stainless steel retaining pin.
- Hydrants shall be Guardian as manufactured by Kennedy Valve or approved equal.

For all your valve requirements, contact a Kennedy Distributor near you or:

## Kennedy Valve

Division of McWane  
1021 E. Water Street  
Elmira, New York 14902-1516  
607-734-2211 FAX: 800-952-4771

Printed in U.S.A.

## INSTALLATION

1. When hydrants are received from manufacturer they should be handled carefully to avoid breakage and damage to flanges. Keep hydrants closed until they are installed. Protect stored hydrants from the elements, if possible.

2. Before installation of hydrants clean piping and elbow of any foreign matter.

3. Install hydrants away from the curb line a sufficient distance to avoid damage from or to overhanging vehicles. A set-back of 2 ft. from the curb line to the point on the hydrant nearest the curb is recommended. The pumper outlet nozzle should face the street. Make sure that the outlet nozzles are high enough above the ground line for hose attachment and that there are no obstructions to prevent operation.

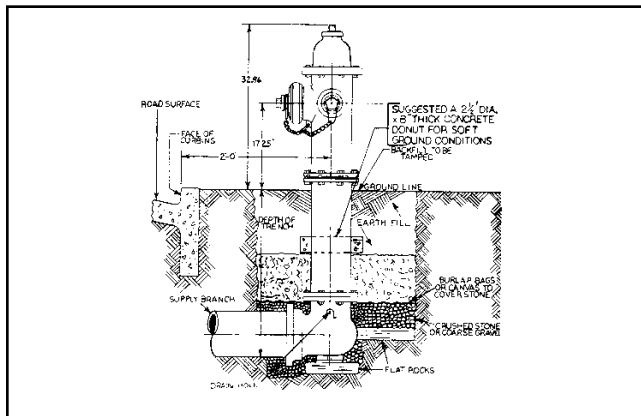

In setting up a hydrant, the elbow should be placed on a flat stone or other solid foundation. It is good practice to brace the side of the base opposite the inlet to oppose the stress due to pressure tending to force the hydrant off the end of the lateral. Hydrants must be firmly supported underground all around the standpipe, especially where there is no concrete sidewalk to help support them. This is particularly important since the proper working of the Safety Breakable Section in severe impact depends upon unyielding support of the underground standpipe.

4. The bottom and lower part of the hydrant should be surrounded with broken stone or coarse gravel so that water released from the standpipe by the drain valves may escape quickly. The stone-filled area should contain a volume of water at least twice that held by the hydrant barrel.

5. Both drainage stone and earth fill above the stone should be tamped to give firm support to the hydrant barrel.

6. It is recommended practice to install an auxiliary or secondary gate valve in the lateral between the hydrant and the main. This permits inspection and repair of hydrant without shutting down mains. Check the hydrant and auxiliary valve for perpendicular setting.

7. After the hydrant is installed and the line as well as the hydrant have been hydrostatically tested, the hydrant should be flushed and then checked for proper drainage.

A. A nozzle cap should be removed, then the hydrant opened fully. This will flush out any dirt or sediment which may have accumulated during installation.

After the hydrant is flushed, close it, replace the nozzle cap, then open the hydrant again and inspect all joints for leaks: Close the hydrant again, remove a hose cap and/or steamer cap to test your hose thread for proper fit.

B. Before replacing the hose cap and/or steamer cap, check the inside of the hydrant for drainage. This can be accomplished by placing the palm of the hand firmly over the nozzle outlet. Drainage rate should be sufficiently rapid to create a suction.

Note:

In certain areas ground water stands at levels above that of hydrant drains. In such cases it is recommended that hydrant drains be plugged at the time of installation. If drains are plugged, hydrants in service in cold climate areas should be pumped out after usage. Mark such hydrants to indicate the need for pumping out after usage.

## OPERATION

The Guardian hydrant requires a minimum of torque to be operated. It is possible to damage the hydrant by forcing it beyond the limits of the operating nut travel with excessive torque; therefore, the following steps are recommended:

1. CHECK DIRECTION OF OPENING as marked on the dirt shield.
2. TO OPEN, DO NOT FORCE THE HYDRANT IN THE OPENING DIRECTION BEYOND FULL OPEN as indicated by sudden resistance to turning. If water does not flow when the hydrant is open, it is probably due to a closed valve upstream from the hydrant.
3. WHEN USING HYDRANT, hydrant should be opened full. Partially opened hydrant may allow substantial leakage through the drain valves. This may prevent the hydrant from draining properly when it is shut down. Operation of hydrant in this manner over a period of time could also undermine the hydrant and/or the water main.
4. TO CLOSE, turn the operating nut until the valve closes off the flow. Always shut off hydrant slowly. In old water mains where corrosion has taken its toll, or even on new mains where high pressure is maintained, closing the hydrant too rapidly could cause a water hammer resulting in damage to the main.

IT IS NOT NECESSARY to **OPEN** or **CLOSE** the hydrant with great force. When closing the hydrant, the closed position will be evident by a reduction in the effort required to close it. When that position has been reached, back off the operating nut in the opening direction one-quarter turn to take the strain off the operating parts of the hydrant and to make it easier to open the hydrant when needed again.

## MAINTENANCE

It is recommended the hydrant be inspected twice yearly, in the spring and fall. In extremely cold weather it is advisable to inspect hydrant after each use.

Maintenance and adjustments are easy and economical with the Guardian hydrant. All parts which are susceptible to damage or rough treatment can be reached without excavation or expensive equipment. The main valve, seat ring, drain valve, drain valve seat and the stem may all be easily withdrawn and replaced by one man.

Inspection or renewal are practical without disturbing the standpipe, pavement or mains. Inspection should cover the following points:

1. Physical examination noting condition of operating nut, nozzle caps and drains, and general appearance.
2. Use an Aquaphone and listen for leakage through main valve.

3. To check for leakage at seals loosen one hose cap one-half turn. Check ease of operation while fully opening hydrant. When all the air has escaped through the hose cap and the hydrant is full, re-tighten the hose cap and check for leakage at joints, packing or seals, and outlet caps.
4. Close hydrant and remove one nozzle cap. Observe drainage.
5. Open hydrant completely, flush hydrant and observe flow. Care should be taken that the water coming from hydrant will not cause any damage to surrounding area.
6. Close hydrant slowly to insure tight closure.
7. Clean and lubricate all nozzle threads. Replace caps, tighten with spanner wrench, then back off slightly so that the caps will not be excessively tight, but have sufficient frictional resistance to prevent removal by hand.
8. Lubricate stem threads through the Alemite fitting centered in the operating nut (one or two pumps with a grease gun).
9. Clean the exterior of the hydrant and repaint, if necessary.
10. Be sure any auxiliary valves are in the wide open position.
11. Keep complete records on inspection and location of all hydrants in the system.

### PROBLEMS AND SOLUTIONS

Various problems which occur in the field are described below with hints on how to solve them.

**Stem Binding:** Rap the hydrant dome with hammer or spanner wrench. This often will unbind the stem. If stem still binding, loosen dome bolts. Stem should then operate easily. Retighten bolts evenly.

**Poor Drainage:** It is possible dirt or pebbles may have plugged the drain holes. Presence of water or ice standing in barrel can be checked using a plumb bob.

To correct:

1. Screw nozzle caps on tightly to prevent leakage.
2. Open hydrant slowly until you hear water entering barrel of hydrant. This will allow water to enter the hydrant with drain valve in an open position. When enough pressure builds up in the barrel any dirt or foreign objects causing the blockage should be forced out.
3. After a few minutes, resume turning the operating nut until the hydrant is fully opened.
4. Slowly shut off hydrant.
5. Remove one of the nozzle caps.
6. Observe through nozzle port to make sure water in barrel is receding. Drainage should be sufficiently rapid to create a suction if palm of hand is placed over a nozzle outlet during drainage.
7. Check again for seat leakage with the Aquaphone.

**Poor Shutoff:** DO NOT exert extra torque forcing hydrant to close. Trouble may be a stone lodged between the seat and the main valve. Forcing closure may damage the hydrant. Stones or other foreign objects are the usual causes of this problem. To correct this problem, remove one or both nozzle caps and open hydrant fully to flush out any foreign material.

Care should be taken that water coming from hydrant will not cause any damage to surrounding area. Attach a canvas apron if necessary, to direct the flow into the street.

Shut off hydrant slowly until fully closed. Put your ear to nozzle opening to hear if water has stopped coming through main valve.

### REMOVING NOZZLES

In 1982 most Guardian hydrants were changed from threaded (12 T.P.I.) nozzle to 1/4-turn nozzle, designed to provide easy replacement in case of damage. Both hose and steamer nozzles are 1/4-turn, left-hand thread segments, and are secured by a stainless steel retaining screw. 1/4-turn nozzles can be removed without difficulty by following these steps:

Instructions to remove 1/4-turn nozzles:

1. Remove nozzle cap (K-8144).
2. Remove nozzle retaining screw (K-8141) using a 1/4" Hex Allen Wrench and turning counter-clockwise.
3. Insert nozzle removing wrench (K-8148) into nozzle (K-8140) and engage nozzle lugs with slots in wrench.
4. Use a 1" diameter bar to turn the nozzle wrench in a **clockwise\*** direction (right) 1/4-turn and remove the nozzle. Note: Nozzles are held in the upper by segments of a **left-hand** thread.
5. Remove the old nozzle "O"-Ring (K-8145).
6. Inspect the nozzle seating surface in the upper barrel (K-8115) and remove any dirt or sediment.
7. Lubricate the new "O"-Ring and place into upper barrel.
8. Insert new nozzle and use nozzle wrench (K-8148) and 1" diameter bar to turn nozzle approximately 1/4-turn counter-clockwise (left). Turn nozzle so the nozzle retaining screw will clear the shoulder on the upper casting when it is inserted.

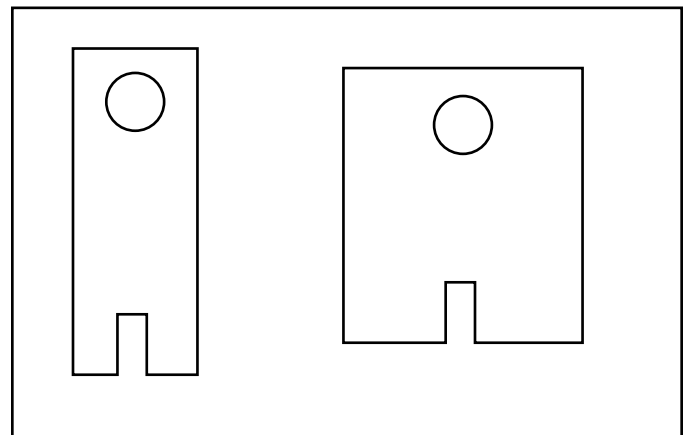

NOZZLE-REMOVING TOOLS K-8148

\*Threaded nozzles are removed by turning to the left or counter-clockwise.

9. Check that the nozzle "O"-Ring is compressed evenly.
10. Lubricate the nozzle retaining screw with a Moly-Type grease and thread it into nozzle until it is between flush and up to 1/8" protruding into the inside of the nozzle.
11. Inspect nozzle cap gasket (K-8143) and replace if necessary.
12. Install nozzle cap and tighten.

### EXTENSION OF GUARDIAN HYDRANT FOR RISE IN STREET GRADE

Height extension of the Guardian hydrant to compensate for a raise in street grade is easily accomplished through the use of the Guardian extension kit (K-8150) without any excavation or interruption of water service and without discarding any parts of the existing hydrant. Extensions are available in 6" increments from 6" to 36"-in length.

The parts supplied with a kit consist of a barrel extension piece and an extension stem of suitable length with all necessary hardware to insert between the upper and lower hydrant sections. The upper barrel and stem sections are connected to the new parts by means of the original standpipe breaking ring and stem coupling.

The entire change can be handled by one man in less than 30 minutes. The new assembly is as rigid and operates as easily as a single piece hydrant.

If the extension increases the overall bury of the hydrant to more than 8 feet, it is strongly recommended that a "deep bury" lower stem be used to minimize chatter.

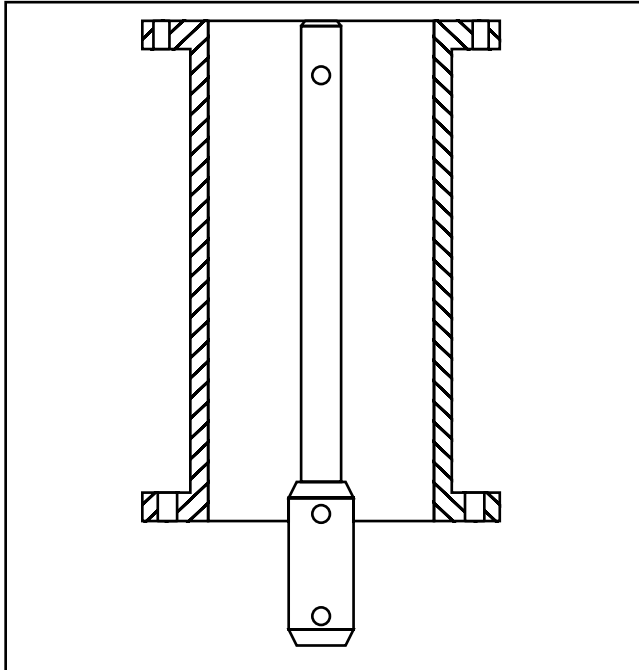

GRADE EXTENSION KIT K-8150

### EXTENSION INSTRUCTIONS

**For hydrants not equipped with Stop Nut on Upper Stem.**

**Stop Nut is furnished on all 4"- and 4-1/2"- Mathews-Guardian Inserts and on Guardian Hydrants where specifications require. See diagram this page.**

1. Remove cap bolts and nuts (K-8108).
2. Remove cap assembly by placing hydrant wrench on the operating nut (K-8102) and turning in direction to open hydrant. Assembly will walk off stem (K-8114).
3. Remove standpipe breaking ring bolts and nuts (K-8118).
4. Remove standpipe breaking rings (K-8119).
5. Lift upper barrel (K-8115) over stem (K-8114).
6. Remove Coupling Pin (K-8122R) from stainless steel lower coupling pin (K-8122R) and remove pin from the coupling (K-8116).
7. Remove upper stem section with coupling (K-8114 & K-8116).
8. Remove extension stem and coupling from kit (K-8150) and fasten stem to coupling with allen socket head coupling pin provided (K-8150 kit).
9. Place extension stem with coupling (K-8150 kit) on lower stem section (K-8123). Line up pin holes and fasten with allen socket head coupling pin provided (K-8150 kit).

10. Place fiber gasket (K-8150 kit) on lower barrel flange.
11. Place extension spool over stem and fasten with bolts and nuts provided (K-8150 kit).
12. Place upper stem section with breaking coupling (K-8114 & K-8116) on extension stem, line up pin holes, insert stainless steel lower coupling pin and fasten with Clevis Pin.
13. Check "O"-Ring (K-8120) on lower flange of upper barrel. If damaged, replace with new "O"-Ring provided (K-8150 kit).
14. Place upper barrel section (K-8115) over stem and orient nozzles in proper position.
15. Replace standpipe breaking rings (K-8119).
16. Insert bolts and nuts (K-8118) and tighten evenly to 30-45 Ft.-Lbs.
17. Check gasket at hydrant cap flange. If damaged, replace with fiber gasket provided (K-8150 kit).

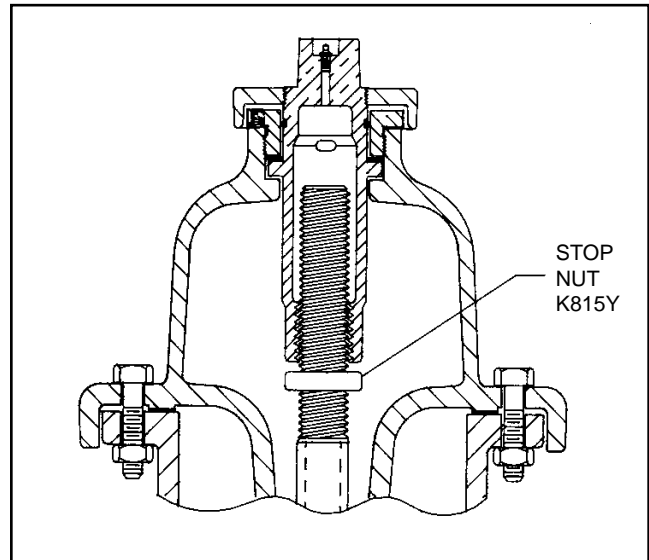

GUARDIAN WITH STOP NUT K-8154  
STOP NUT REMOVAL WRENCH K-8155  
AVAILABLE UPON REQUEST

18. Place cap assembly (K-8107) over hydrant stem carefully so as not to damage "O"-Rings (K-8111) and turn in direction to close hydrant. Insert two cap bolts (K-8108) to align flanges and draw down until snug.
19. Replace cap bolts and nuts (K-8108) and tighten.
20. Cycle hydrant to test for leaks or binding.

### DIRECTIONS FOR REPAIRING BREAKING COUPLINGS ON K-81A, K81AD, K81AW HYDRANTS

**For hydrants not equipped with Stop Nut on Upper Stem. Stop Nut is furnished on all 4"- and 4-1/2"- Mathews-Guardian Inserts and on Guardian Hydrants where specifications require. See diagram-page 5.**

1. Remove broken stem breaking coupling and standpipe breaking rings.
  - A. Remove the broken stem breaking coupling (Item K-8116) from the lower stem and remove the lower coupling.

- B. With a socket wrench, remove the bolts (Item K-8118) holding the broken standpipe breaking rings (Item K-8119) pieces and remove the pieces. Lay the hydrant upper on the ground.
- 2. Remove stem from hydrant upper.
  - A. Unscrew the upper stem (Item K-8114) from the operating nut (Item K-8102) by holding the stem stationary and turning the operating nut in the direction to open.
  - B. Remove broken upper stem breaking coupling (Item K-8116) and the upper coupling pin.
- 3. Install new stem coupling.
  - A. Place the new stem breaking coupling (K-8149 kit) on the upper stem and secure with the upper coupling pins provided (K-8149 kit).
  - B. Slide the upper stem and coupling assembly over the lower stem. Push in the lower coupling clevis pin and fasten with the bridge pin.
- 4. Remove the cap from hydrant upper.
  - A. Place the hydrant upper barrel (Item K-8115) on cardboard or other clean surface.
  - B. With a socket wrench, remove the bolts (Item K-8108) holding the cap (Item K-8107) to the upper barrel and remove cap.
- 5. Reassemble hydrant.
  - A. Check the "O"-Ring (Item K-8120) on the bottom of the hydrant upper barrel. Replace if damaged (K-8149 kit).
  - B. Set the hydrant upper barrel over the stem and orient the nozzles in the direction required.
  - C. Place the breaking rings on the lower barrel (Item K-8124) flange and around the upper barrel. Replace the bolts in the breaking rings and finger tight.
  - D. Replace the hydrant cap gasket (Item K-8109) (K-8149 Kit) and lower the cap over the stem. (Be careful not to damage the "O"-Rings (Item K-8111) in the cap.) Start the upper stem into the operating nut by turning the operating nut in the direction to close. Turn until the cap is seated on the upper barrel.
  - E. Replace the cap bolts (Item K-8109) and tighten.
  - F. Tighten the breaking rings bolts (Item K-8118) evenly to 30-45 Ft./Lb.

NOTE: CHECK FOR FREE OPERATION BY CYCLING THE HYDRANT FROM FULLY OPEN TO FULLY CLOSED.

**DESCRIPTION: COLLISION REPAIR KIT – K81A, K81AD, K81AW**

**5-1/4"-ITEM #1-58008  
4-1/2"-ITEM #1-58007**

DESCRIPTION	QUANTITY
Stem breaking coupling	1
Breaking ring	2
Flange seal "O"-Ring	1
Gasket hydrant cap	1
Coupling Pin	2
Screw hex head plated 1/2" x 2-3/4"	8
Nut finished hex plated 1/2"	8
Instruction Sheet	1

**PROPER TOOLS REQUIRED**

Figure 111 spanner wrench with proper sized operating nut opening	1
Hammer	1
Pliers	1
3/8"- or 1/2"-drive ratchet with 3/4"-socket	1
<b>AND</b>	
3/4"-open or box end wrench	1
<b>OR</b>	
3/4"-open or box end wrenches	2

**DIRECTIONS FOR USING HYDRANT SEAT**

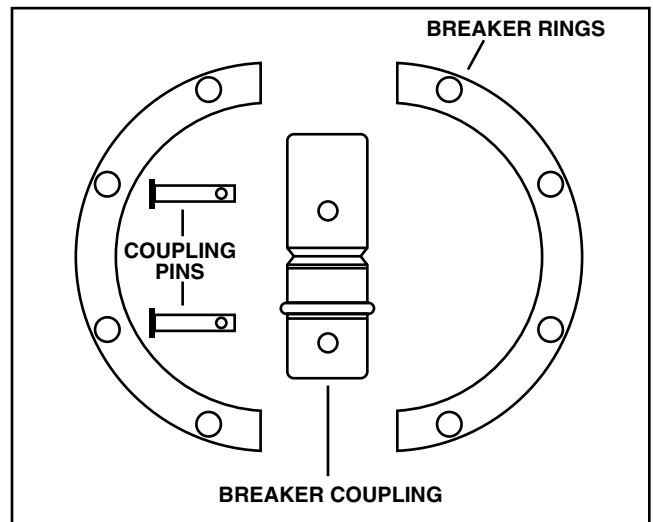

COLLISION REPAIR KIT K-8149

**REMOVING WRENCH ON GUARDIAN HYDRANT**

**For hydrants not equipped with Stop Nut on Upper Stem. Stop Nut is furnished on all 4"- and 4-1/2"- Mathews-Guardian Inserts and on Guardian Hydrants where specifications require. See diagram- page 5.**

- 1. Shut off Water Supply.
  - A. Shut off water supply to hydrant by closing the gate valve controlling flow of water to the hydrant. Remove a nozzle cap and open the hydrant a maximum of three turns. Remember, for operator safety, remove the nozzle cap before opening the hydrant.

2. Removal of Hydrant Cap.
  - A. With a socket wrench, take out the bolts (K-8108) holding the cap (K-8107).
  - B. Turn the operating nut (K-8102) in the direction to open and hold the cap to keep it from rotating as the operating nut unscrews and lifts the cap. Turn until the operating nut walks off the stem (K-8114).
  - C. Lift the cap straight up and off. Take care not to damage the "O"-Rings (K-8111) in the lower part of the cap.
3. Removal of Stem and Drain Valve Assembly
  - A. Slide the seat removing wrench (K-8147) over the stem and down into the upper barrel (K-8115). Thread the seat removing stem nut (K-8147) on to the stem.
  - B. Turn the wrench while tightening the nut to align it with the stem breaking coupling (K-8116). This will allow the coupling to be drawn into the wrench.
  - C. Lift on the wrench, to pull the drain valve (K-8136) firmly into the seat ring (K-8128) and turn the wrench counter-clockwise to unscrew the seat ring.
  - D. Lift the entire drain valve and stem assembly, with the seat ring and seat removing wrench, out of the standpipe. Do not allow the seat ring to rub against the lower.
  - E. Inspect to be sure "O"-Rings (K-8126A and K-8130) are not in the standpipe.
4. Inspect and Replace, if Necessary, Hydrant Components.
5. Reassemble Hydrant.
  - A. Place the seat ring, stem, breaking coupling and hydrant drain valve as a unit into the wrench. Check to assure "O"-Rings (K-8126A and K-8130) are in place. Engage the wrench (K-8147) on the stem breaking coupling and tighten.
  - B. Insert this assembly into the barrel and lower slowly and carefully to avoid damaging the o-rings.
  - C. Turn the wrench one full turn counter-clockwise to line up the threads to prevent cross-threading. Then turn clockwise to tighten the seat ring. Tighten to 100 Ft.-Lbs. +100/-0 Ft.-Lbs.

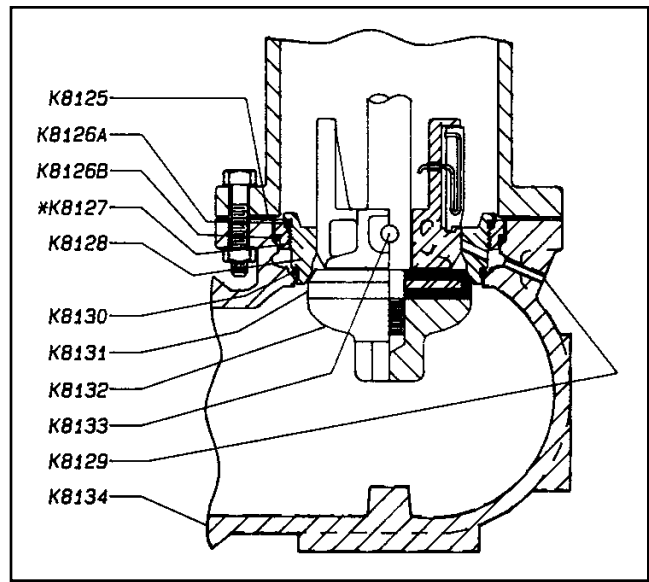

GUARDIAN 4 1/2"

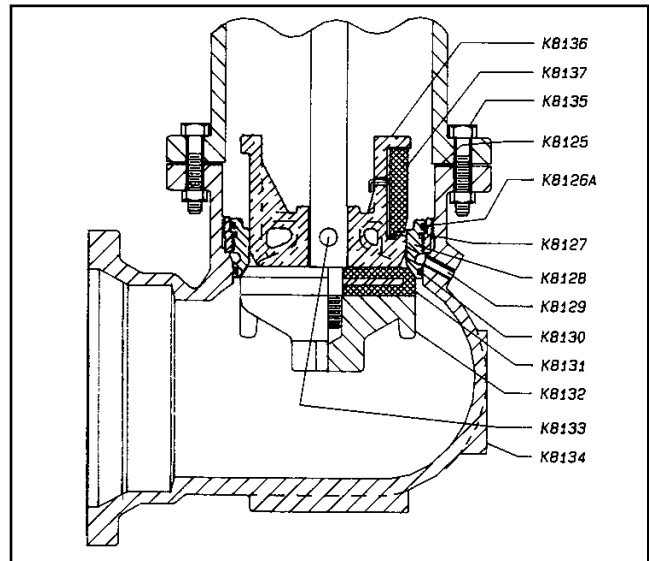

GUARDIAN 5 1/4"  
Old Style Drain Valve & Bottom Plate

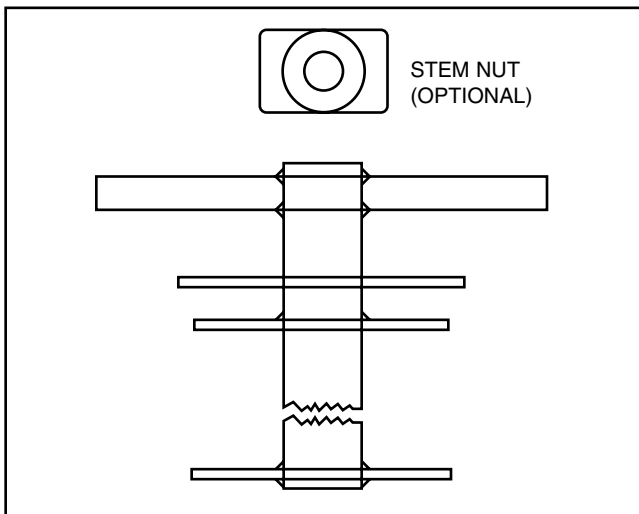

SEAT REMOVING WRENCH K-8147

- D. Remove the wrench.
- E. Lower the cap assembly onto the stem carefully so as not to damage "O"-Rings and turn the operating nut in the direction to close the hydrant, until the cap seats on the barrel, align the bolt holes in the cap and bolt to the barrel.
- F. Close the hydrant and open the gate valve controlling flow of water to the hydrant.
- G. Cycle hydrant to check for free operation.
- H. Close hydrant, wait for hydrant to drain, then reinstall nozzle cap and tighten.



# Kennedy Valve

## GUARD YOUR WATER SYSTEM FROM ACCIDENT OR ATTACK



### Patriot Hydrant Check Valve

Threats to water supply can come from either accidental or deliberate acts. Our nation's water superintendents have safeguarded nearly all of the access points to our drinking water. At this time one critical access point left unprotected is the fire hydrant.

The Patriot Hydrant Check Valve prevents reverse flow through the fire hydrant, safely protecting our drinking water while providing a full port unobstructed waterway that allows our firefighters the water they need when they need it.

Unlike locks and special external devices, the Patriot is installed underground which prevents tampering and allows the hydrant to be operated the moment the firefighters arrive on the scene. The Patriot check valve can be installed on any 6" mechanical joint connection, ensuring compatibility with all hydrant brands—providing the flexibility and cost effectiveness you demand.

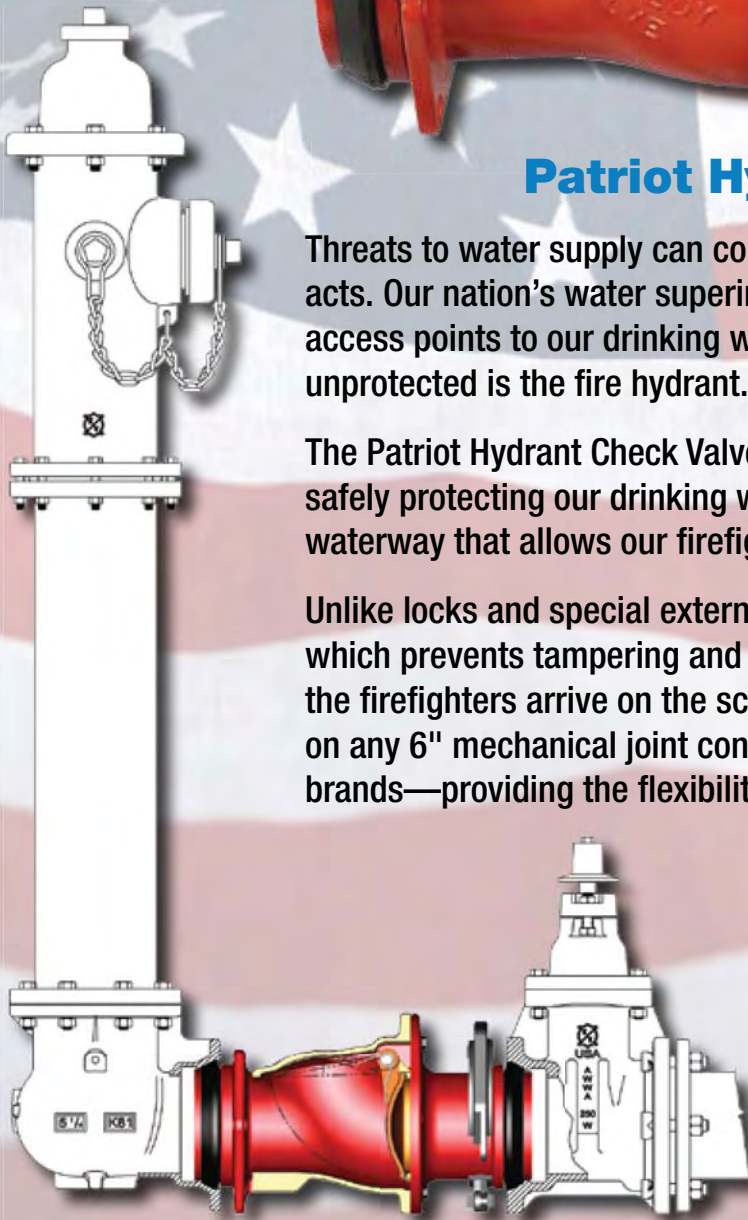

Updated 02/14/12



# Kennedy Valve



# Specifications

1. The Patriot Fire Hydrant Check Valve shall be manufactured to all of the testing and performance standards of AWWA C508 and AWWA C550. The Check Valve shall be designed for 250 PSI working pressure and tested to 500 PSI hydrostatic pressure.
2. The Check Valve shall be a stand alone unit able to be positively restrained to any 6" mechanical joint fire hydrant shoe.
3. The Check Valve shall be ductile iron ASTM Standard A536 (70-50-5), with NSF approved fusion bonded epoxy coating (interior/exterior).
4. The Check Valve shall be lead free, with no exposed lead bearing surfaces.
5. The Check Valve shall have an unobstructed waterway. No reduction of port or redirection of flow will be allowed.
6. The seat shall be retained via a double dove tail o-ring retaining groove design to ensure a positive seal.
7. The Check Valve shall incorporate integral positive restraint connections that maintain a restrained connection between the fire hydrant and the gate valve.
8. The Check Valve shall incorporate a stainless steel spring that hastens positive closure and prevents water hammer.
9. All fasteners shall be 304 stainless steel and all interior rubber components shall be EPDM rubber.
10. The Check Valve shall be produced with no less than 80% post consumer recycled content while being cast, manufactured, assembled and tested in the United States of America.

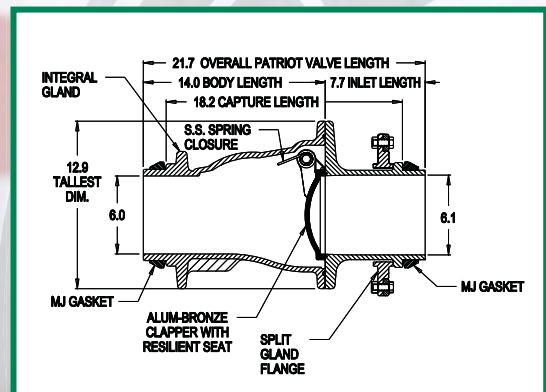
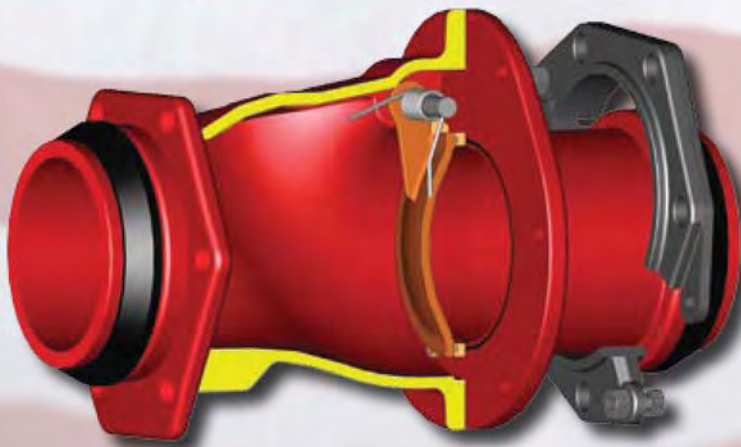

**Kennedy Valve**

1021 East Water Street • Elmira, New York 14902-1516 • Ph: 607.734.2211 • Fax: 607.734.3288  
Web Site: [www.kennedyvalve.com](http://www.kennedyvalve.com) Updated 02/14/12



# **Kennedy Valve**

A DIVISION OF McWANE, INC.

[www.kennedyvalve.com](http://www.kennedyvalve.com)

2009

1021 E. Water Street • Elmira, New York 14901

P.O. Box 981

PHONE: (607) 734-2211 • FAX: 1-800-952-4771