

**NOBLE SERIES**  
*ELECTRICALLY HEATED  
UNDERCOUNTER  
DISHMACHINES*

**INSTALLATION, OPERATION  
& SERVICE MANUAL**



FOR NOBLE MODEL(S):

**NOBLE UH30**  
**NOBLE UL30**





# REVISION HISTORY

Revision Letter	Revision Date	Made By	Applicable ECNs	Details
A	06-04-15	KAP	N/A	Release to production



**NOBLE UH30**

High temperature, hot water sanitizing, with a booster tank.  
Detergent & rinse aid chemical feeder pumps.

**NOBLE UL30**

Low temperature, chemical sanitizing, no booster tank.  
Detergent, rinse aid & sanitizer chemical feeder pumps.  
Detergent & rinse aid chemical feeder pumps

Model: \_\_\_\_\_

Serial No.: \_\_\_\_\_

Installation Date: \_\_\_\_\_

Service Rep. Name: \_\_\_\_\_

Phone Number: \_\_\_\_\_

**SPECIFICATIONS**

NOBLE UH30 & UL30 DIMENSIONS ..... 1  
 OPERATING PARAMETERS ..... 3  
 ELECTRICAL REQUIREMENTS ..... 4

**INSTRUCTIONS**

INSTALLATION ..... 5  
 OPERATING ..... 14  
 DELIME ..... 16

**MAINTENANCE**

PREVENTATIVE MAINTENANCE ..... 17  
 TROUBLESHOOTING ..... 19

**PARTS**

CONTROL PANELS ..... 21  
 KICK PANEL WELDMENT ..... 24  
 TERMINAL BLOCK BOX ASSEMBLY ..... 25  
 PERIPUMP TRACK ASSEMBLIES ..... 26  
 CHEMICAL FEEDER PUMP ASSEMBLIES ..... 28  
 CHEMICAL FEEDER PUMP COMPONENTS ..... 30  
 PLUMBING ASSEMBLIES ..... 31  
 VACUUM BREAKER REPAIR PARTS KIT ..... 33  
 WASH MANIFOLD ASSEMBLY ..... 35  
 MOTOR & PUMP ASSEMBLY ..... 37  
 RINSE ARM & WASH ARM ASSEMBLIES ..... 39  
 UH30 THERMOSTAT & RINSE TANK ASSEMBLY ..... 40  
 NOBLE UL30 OPTIONAL THERMOSTAT & HEATER COMPONENTS ..... 41  
 DOOR ASSEMBLY ..... 42  
 CLYDE SWITCH ARM ..... 44  
 MISCELLANEOUS DOOR COMPONENTS ..... 45  
 FRAME AND PANEL COMPONENTS ..... 47  
 MISCELLANEOUS PARTS ..... 49  
 STANDS & COMPONENTS ..... 50  
 HTS-11 SCALE PREVENTION & CORROSION CONTROL DEVICE ..... 51  
 GO BOX KIT ..... 52  
 VACUUM SWITCH ASSEMBLY ..... 53  
 VACUUM SWITCH ASSEMBLY INSTALLATION ..... 54

**SCHEMATICS**

NOBLE UH30 208-230 VOLT, 60 HERTZ, SINGLE PHASE ..... 55  
 NOBLE UH30 480 VOLT, 60 HERTZ, THREE PHASE ..... 56  
 NOBLE UL30 115 VOLT, 60 HERTZ, SINGLE PHASE ..... 57

# SPECIFICATIONS

# UH30 MACHINE DIMENSIONS

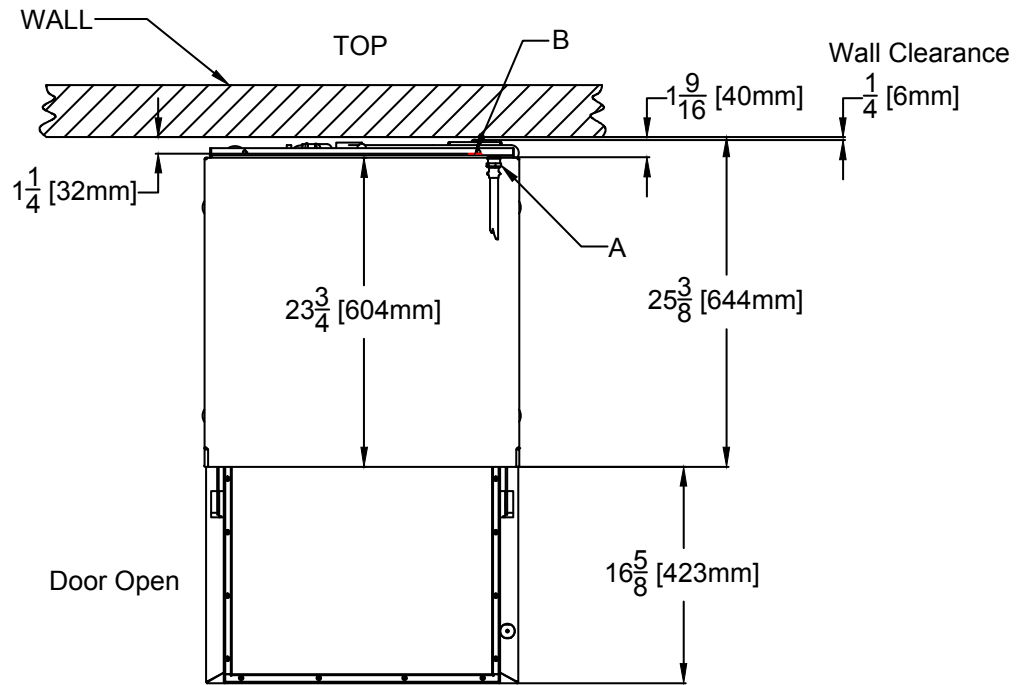

### LEGEND:

A - Water Inlet - 1/2" Female Pipe Thread, 2 1/2" AFF (Connect to a true 1/2" ID water line)

B - Electrical Connection

C - Drain Connection - 10' coiled drain hose. Shipped inside machine. Must be installed no more than 24" AFF.

All dimensions from floor can be increased 1" with adjustable feet supplied.

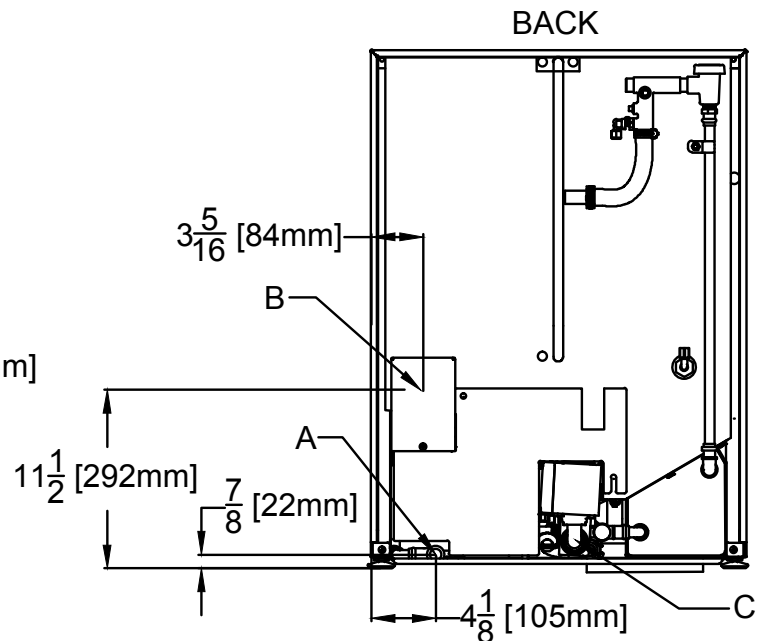
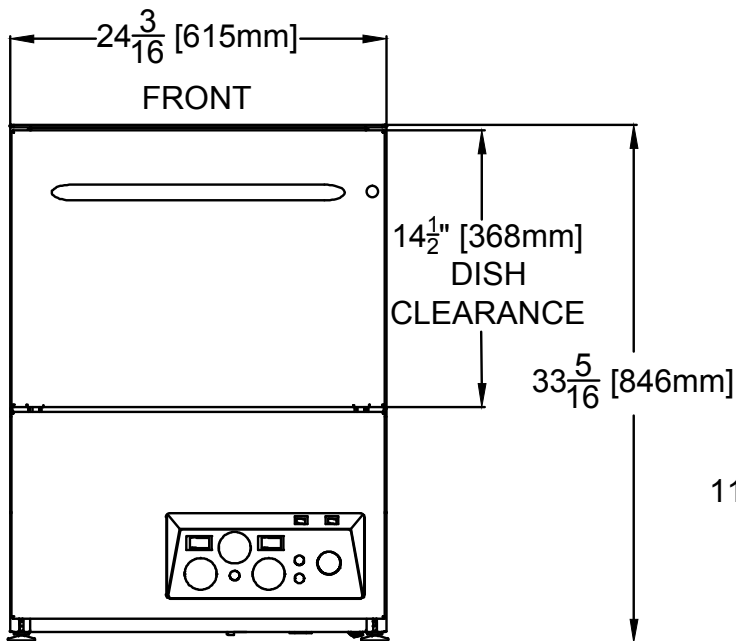

\*All dimensions are for reference only and are subject to change without notice.

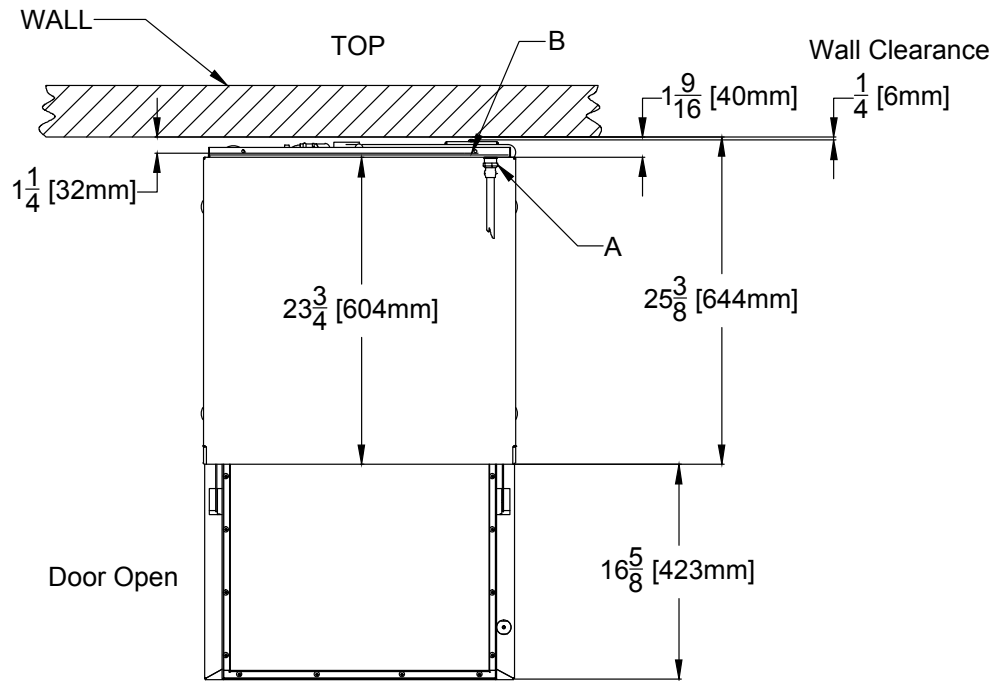

**LEGEND:**

A - Water Inlet - 1/2" Female Pipe Thread, 2 1/2" AFF (Connect to a true 1/2" ID water line)

B - Electrical Connection

C - Drain Connection - 10' coiled drain hose. Shipped inside machine. Must be installed no more than 24" AFF.

All dimensions from floor can be increased 1" with adjustable feet supplied.

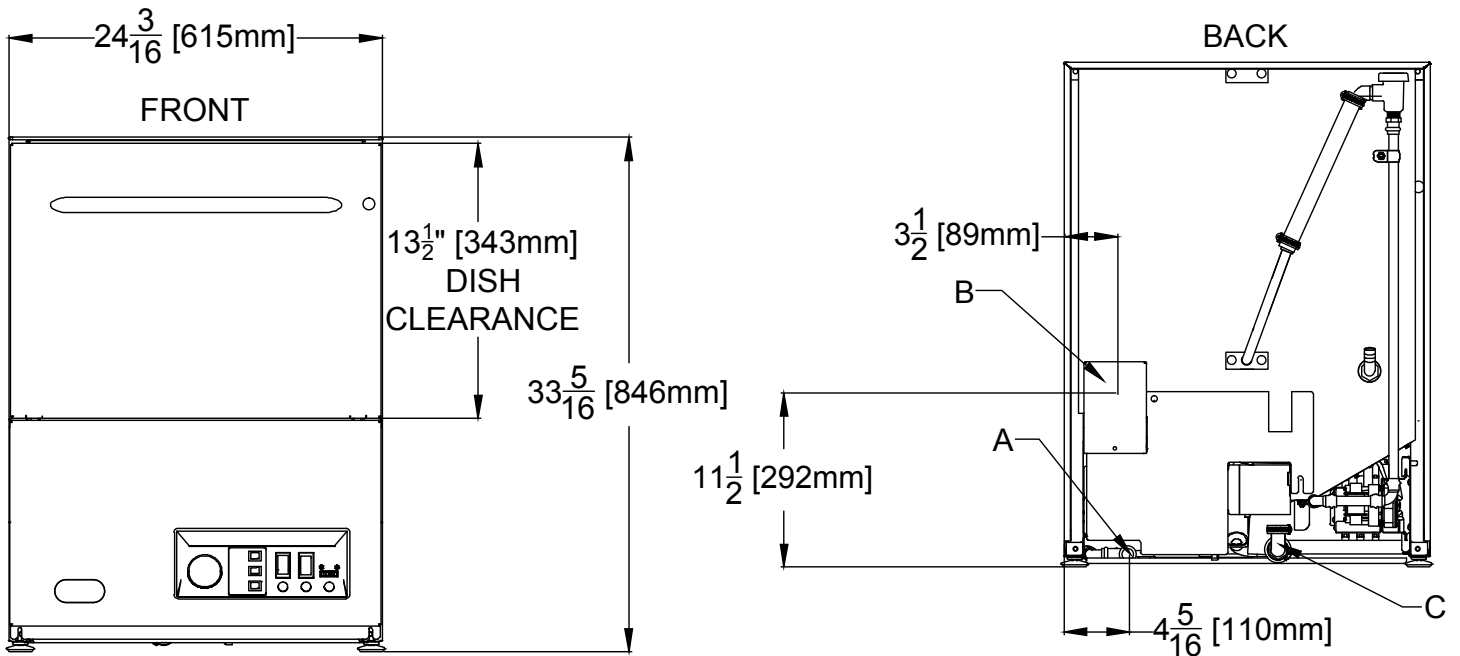

\*All dimensions are for reference only and are subject to change without notice.

<b>Model Designation:</b>	<b>NOBLE UH30</b>	<b>NOBLE UL30</b>
<b>Operating Capacity:</b>		
Racks per Hour	24	24
Dishes per Hour	600	600
Glasses per Hour	864	864
<b>Tank Capacity (Gallons):</b>		
Wash Tank	1.1	1.2
Rinse Tank	1.1	3.0
<b>Electrical Loads (as applicable):</b>		
Wash Motor HP	0.75	0.75
Rinse Heater KW	8.2	N/A

**NOTE: Always refer to the machine data plate for specific electrical and water requirements. The material provided on this page is for reference only and is subject to change without notice.**

**HOT WATER SANITIZING**

**Water Temperatures (Fahrenheit):**

Minimum Wash Temperature	150	N/A
Minimum Rinse Temperature	180	N/A
Minimum Incoming Water Temperature	110	N/A

**Chemical Sanitizing:**

**Water Temperatures (Fahrenheit):**

Minimum Wash Temperature	N/A	120
Minimum Rinse Temperature	N/A	120
Minimum Incoming Water Temperature	N/A	120

**Other Water Requirements:**

Water Flow Pressure (PSIG)	20	20
Flow Rate Minimum (GPM)	0.44	0.48
Water Line Size (NPT)	1/2"	1/2"
Drain Line Size (NPT)	1-3/8"	1/2"
Minimum Chlorine Required (PPM)	N/A	50



All electrical ratings provided in this manual are for reference only. Always refer to the machine data plate to get the exact electrical information for your machine. All electrical work performed on machines should be done in accordance with applicable local, state, territorial and national codes. Work should only be performed by qualified electricians and authorized service agents.

Note that all electrical wiring used in the NOBLE UH/UL30 series of machines must be rated, at a minimum, for 100°C (212°F). Furthermore, use copper conductors only.

Where applicable, heating element amperage draws have been adjusted for the assumed input voltage. Noble assumes incoming voltages will be either 208, 230 or 460 volts. Some of the heating elements used in our machines are actually rated for other voltages, such as 240 or 480 volts. Always verify the amperage draw of the machine in operation when sizing circuit protection.

If your machine is equipped with the optional rinse heater, note the rinse heater has its own electrical connection and therefore requires a separate service. Amperage loads for motors and heaters are called out on the machine data plate for the installation/service technician.

The electrical configurations of the NOBLE UH/UL30 series of machines are as follows:

**Available Electrical Characteristics:**

- 115 volt, 60 Hz, single phase
- 208 volt, 60 Hz, single phase
- 230 volt, 60 Hz, single phase
- 460 volt, 60 Hz, three phase

**Available Wash Tank Heaters:**

- 8.2KW (standard for NOBLE UH30)

**NOBLE UH30**

**Electrical Characteristics**

<b>VOLTS</b>	208	230	460
<b>PHASE</b>	1	1	3
<b>FREQ</b>	60	60	60
<b>WASH MOTOR AMPS</b>	6.6 A	6.6 A	1.3A
<b>RINSE HEATER AMPS</b>	32.2 A	35.7 A	42.3 A
<b>FLA</b>	38.8 A	42.3 A	13.3

**NOBLE UL30**

**Electrical Characteristics**

<b>VOLTS</b>	15
<b>PHASE</b>	1
<b>FREQ</b>	60
<b>WASH MOTOR AMPS</b>	13.2 A
<b>RINSE HEATER AMPS</b>	N/A
<b>FLA</b>	13.2

**VISUAL INSPECTION:** Before installing the unit, check the container and the machine for damage. A damaged container may be an indication there is possible damage to the machine. If there is any type of damage to both the container and the unit, **DO NOT THROW AWAY THE CONTAINER.** The dish-machine has been previously inspected at the factory and is expected to arrive to you in new, undamaged condition. However, rough handling by carriers or others may result in damage to the unit while it is in transit. If such a situation occurs, **DO NOT RETURN THE UNIT TO NOBLE.** Instead, contact the carrier and ask them to send a representative to the site to inspect the damage. You should request that an inspection report be completed. You must contact the carrier within 48 hours of receiving the machine in order to report possible freight damage. You are also encouraged to contact the dealer through which you purchased the unit.

**DO NOT THROW AWAY  
CONTAINER IF DAMAGE  
IS EVIDENT**

---

**UNPACKING THE MACHINE:** The machine should be unboxed and/or removed from the pallet prior to installing. Open the front door and remove all of the materials from the inside. Once unpacked, verify there are no missing parts to the best of your ability. If you discover a part is missing, contact Noble immediately.

---

**LEVEL THE DISHMACHINE:** The dish-machine is designed to operate while level. This is important to prevent any damage to the machine during operation and to ensure the best results possible. The unit comes equipped with adjustable feet, which can be turned using a pair of channel locks or by hand. Verify the unit is level from front to back and side to side prior to making any electrical or plumbing connections.

---

**PLUMBING THE DISHMACHINE:** All plumbing connections must be made to adhere to local, state, territorial and national codes. The installing plumber is responsible for ensuring the incoming water lines are flushed of debris prior to connecting to the machine. Note that chips and materials from cutting processes can become lodged in the solenoid valves and prevent them from opening or closing. Any valves that are found to be fouled or defective because of foreign matter left in the water line, and any subsequent water damage, are not the responsibility of the manufacturer.

***A water hardness test must be performed.***

A water hardness test must be performed to determine if the HTS-11 (scale prevention & corrosion control) need to be installed. A hardness test kit is attached to the warning tag that is attached to the incoming plumbing connection on the back of the machine. If the hardness is higher than 5 GPG the HTS-11 will need to be installed. Please contact Noble immediately to have this shipped to you.

**WATER SUPPLY CONNECTIONS:  
WATER HARDNESS GREATER THAN  
5 GPG**

Ensure you have reads the above section entitled “PLUMBING THE MACHINE” above before proceeding. Install the HTS-11 into the water line (1/2” ID pipe size minimum) before the dish machine line incoming water connection point using copper pipe. The HTS-11 must be installed vertically. A mounting bracket is provided to facilitate the venture metering head to the wall. Observe proper inlet/outlet water directions. Flow directions are molded into the top of the head. It is recommended that a water shut off valve be installed before the HTS-11 to allow access for servicing. Plumb from the HTS-11 outlet to the incoming water connection point using copper pipe (or order the 1/2” ID flexible hose kit offered by Noble). The water supply is to be capable of 20 PSI (plus or minus 5 PSI) “flow” pressure at the recommended temperature indicated on the data plate. See “Shock Absorber” section.

**WATER SUPPLY CONNECTION:  
WATER HARDNESS OF 5 GPG OR LESS**

Ensure you have read the section entitled “PLUMBING THE DISH MACHINE” before proceeding. Install the water supply line (1/2” ID pipe size minimum) to the dish machine incoming water connection point using copper pipe (or order the 1/2” ID flexible hose kit offered by Noble). It is recommended that a water shut off valve be installed in the water line between the main supply and the machine to allow access for service. The water supply line is to be capable of 20 PSI (plus or minus 5 PSI) “flow” pressure at the recommended temperature indicated on the data plate.

**CHEMICAL CONNECTIONS:**

Upon first installation, the chemical alarm will buzz until the chemical feeder pumps are primed. If the chemicals run out, the chemical alarm will buzz until the chemical is replaced and primed if necessary. The bottom of the chemical container cannot be located any higher than 8” from the floor. If the unit is shipped with a 6” or 18” table stand, then the highest position will be respectively 14” or 26” from the floor.

**PRESSURE REGULATOR:**

Noble offers a water pressure regulator that can be purchased separately. Regulators help areas where the water pressure fluctuates or is lower than the recommended pressure. DO NOT confuse STATIC pressure with FLOW pressure. Static pressure is the line pressure in a “no flow” condition (all valves and services are closed). Flow pressure is the pressure in the fill line when the valve is opened during the cycle.

**SHOCK ABSORBER:**

Also, it is suggested that a shock absorber (NOT SUPPLIED) be installed on the incoming water line. This prevents water hammer (hydraulic shock), induced by the solenoid valve as it operates, from causing damage to the equipment.

*Take care not to confuse static pressure with flow pressure.*

**CONNECTING THE DRAIN LINE:**

The dish machine has a pumped (pressure) drain capable of pumping waste water to a height of 24" above the floor to the kitchens drain system. Each dish machine is supplied with a six foot long hose. This ships **INSIDE** the unit. When installed, it will extend from the rear side of the machine. There also must be an air gap between the machine drain line and the floor sink or drain. If a grease trap is required by code, it should have a flow capacity of 12 GPM (Gallons Per Minute).

**PLUMBING CHECK:**

Slowly turn on the water supply to the machine after the incoming fill line and the drain line have been installed. Check for any leaks and repair as required. All leaks must be repaired prior to placing the machine into operation.

**ELECTRICAL POWER CONNECTIONS:**

Electrical and grounding conductors must comply with the applicable portions of the National Electric Code ANSI/NFPA 70 (latest edition) and/or other electrical codes.

**DISCONNECT ELECTRICAL POWER SUPPLIES & TAG OUT IN ACCORDANCE WITH APPROPRIATE PROCEDURES & CODES AT THE DISCONNECT SWITCH TO INDICATE THE CIRCUIT IS BEING SERVICED.**

The data plate is located toward the right front side of the dish machine. Refer to the data plate for machine operating requirements, machine voltage, total amperage & serial number.

To install the incoming power lines, remove the back panel. This will require taking a Phillips head screw driver and removing the two screws at the bottom of the back panel; remove the back panel and set aside. Install 3/4" conduit into the pre-punched holes in the back of the control box. Route power wires and connect to power block and grounding lug. Install the service wires (L1 and L2) to the appropriate terminals as they are marked on the terminal block. Install the grounding wire into the lug provided. It is recommended that "DE-OX" or another similar anti-oxidation agent be used on all power connections.

**VOLTAGE CHECK:**

Ensure that the power switch is in the OFF position and apply power to the dish machine. Check the incoming power at the terminal block and ensure it corresponds with the voltage listed on the data plate. If not, contact a qualified service agency to examine the problem. Do not run the dish machine if the voltage is too high or too low. Shut off the service breaker and mark it as being for the dish machine. Advise all proper personnel of any problems and of the location of the service breaker. Replace the control box cover and tighten down the screws.

**SURROUNDING AREA:**

This is a commercial dish machine and reaches temperatures that can exceed those generated by a residential machine. Therefore, any surrounding countertops, cabinets, flooring material & sub floor material must be designed and/or selected with these higher temperatures in mind.

**Note: any damage to surrounding area that is caused by heat and or moisture to materials selected that are NOT recommended for higher temperatures will not be covered under warranty or by Noble Warewashing.**

**THERMOSTATS:** The thermostats on your NOBLE UH/UL30 unit have been set at the factory. They should only be adjusted by an authorized service agent.

---

**CHEMICAL FEEDER EQUIPMENT:** This equipment is not recommended for use with deionized water or other aggressive fluids. Use of deionized water or other aggressive fluids will result or corrosion and failure of materials and components. Use of deionized water or other aggressive fluids will void the manufacturers warranty.

**NOTE:** The bottom of the chemical container cannot be located any higher than 8" from the floor. If the unit is equipped with the 6" or 18" table stand, then the highest position will respectively be 14" or 26" from the floor. this, contact Noble immediately for assistance.

It is important to remember that if you decide to operate the unit in chemical sanitizing mode, you must ensure an appropriate chlorine-based sanitizer is used in the final rinse line.

**WARNING! CHLORINE BASED SANITIZERS CAN BE DETRIMENTAL TO YOUR MACHINE IF THE CHEMICAL SOLUTION IS TOO STRONG. SEE YOUR CHEMICAL PROFESSIONAL TO ENSURE YOUR DISPENSER IS SET UP CORRECTLY.**

---

**TO PREPARE CHEMICAL FEEDER PUMPS FOR OPERATION:** The NOBLE UH30 dish machine is supplied with integral detergent and rinse aid chemical feeder pumps. The NOBLE UL30 dish machine is supplied with integral detergent, rinse additive, and sanitizer chemical feeder pumps. Locate the open ends of the chemical tubes with the tube stiffeners and place each one in the appropriate container.

- A. Red Tubing=Detergent
  - B. Blue Tubing= Rinse Aid
  - C. White Tubing= Sanitizer
- 

**PRIMING CHEMICAL FEEDER PUMPS:** Chemical feeder pumps need priming when the machine is first installed or if for some reason, the chemical lines have been removed and air is allowed to enter.

**CAUTION! Water must be in the sump and wash tank prior to the dispensing of chemicals. Sanitizer in concentration is caustic and may cause damage without dilution.**

**PRIMING CHEMICAL  
FEEDER PUMPS  
(CONTINUED):**

1. Verify that the proper chemical tube stiffener inlet is in the proper container.
2. Use the prime switches located on the control panel at the bottom of the unit to prime each pump. The switches are clearly marked as to what chemical feeder pump they are assigned to.
3. To prime the pumps, hold the switch in the momentary position until chemical can be observed entering the pump.
4. Detergent is dispensed as required during the wash cycle by the timer. The amount of detergent may need to be increased or decreased depending upon water quality and type of detergent.
5. Rinse additive is dispensed as required into the final rinse. The amount of rinse additive may need to be adjusted depending upon water hardness & results.
6. Sanitizer (either chlorine or iodine) is dispensed into the final rinse. The amount of sanitizer may need to be adjusted depending on the concentration and type of sanitizer used.
7. Please refer to the next page for instruction on adjusting the chemical feeder pumps on the universal timer.

**WARNING: Some of the chemicals used in dish washing may cause chemical burns if they come in contact with your skin. Wear protective gear when handling these chemicals. If you do come in contact with these chemicals, immediately follow the instructions provided with the chemicals for treatment.**

**PROGRAMMING  
INSTRUCTIONS  
FOR CHEMICAL  
FEEDER PUMPS  
(INSTALLATION  
TECHNICIAN ONLY):**

To access the programming mode, the machine must be ON and idle (between cycles).

On the timer board, press and hold both the MOVE and ENTER buttons on the timer board simultaneously for two seconds.

The PROGRAM (PGM) light and light A will illuminate.

**NOTE:** Once in the programming mode, the MOVE button is used to scroll between the programming categories and the ENTER button is used to select the category.

Press the MOVE button to move the solid light to the desired location of FILL, RINSE AID, DETERGENT, or SANITIZER. Please note that options A, B, C and D are not adjustable outputs.

Press the ENTER button for the chosen category. Now, the (PGM) light will illuminate along with lights corresponding to the time values for the chosen category. The ACCEPT light will blink.

The PROGRAM light will illuminate.

To change the value of a parameter, use the MOVE button to illuminate the light next to the time option (time is measured in seconds). In the time categories, each second in use will light up. To deselect the option, press ENTER and the light will go off, press ENTER again and it will illuminate. Once you have set your time category, press the MOVE button until the ACCEPT light illuminates and press ENTER. This will save the changed parameters.

Once you press the ENTER button when the ACCEPT light is blinking you will exit the programming mode. To change any other values, you will have to return to the programming mode. To revert back to a previous setting, you must return to that option and change the parameter back to the previous setting.

Once in the programming mode, if there have been no keypad inputs for approximately two minutes, the system will automatically exit out of the programming mode. Any changes to parameters will be saved when the programming mode is automatically exited.

The wash and drain cycles are not adjustable.

All time adjustments are in seconds. Refer to the chart on the following page for adjustable outputs.

**PROGRAMMING  
INSTRUCTIONS  
FOR CHEMICAL  
FEEDER PUMPS  
(INSTALLATION  
TECHNICIAN ONLY):**

PGM	NOBLE UH30	NOBLE UL30
E	Not Adjustable	Rinse Aid
F	Rinse	Fill
G	Detergent	Sanitizer
H	Rinse Aid	Detergent

TIMER PROGRAMMING BOARD

PGM		TIME IN SECONDS
A	<input type="text"/>	8
B	<input type="text"/>	4
C	<input type="text"/>	2
D	<input type="text"/>	1
E	<input type="text"/>	0.8
F	<input type="text"/>	0.4
G	<input type="text"/>	0.2
H	<input type="text"/>	0.1
ACCEPT	<input type="text"/>	

MOVE

ENTER



**DETERGENT CONTROL:** Detergent usage and water hardness are two factors that contribute greatly to how efficiently your dish machine will operate. Using detergent in the proper amount can become, in time, a source of substantial savings. A qualified water treatment specialist can tell you what is needed for maximum efficiency from your detergent, but you should still know some basics so you'll understand what they are talking about.

First, you must understand that hard water greatly effects the performance of the dish machine. Water hardness is the amount of dissolved calcium and magnesium in the water supply. The more dissolved solids in the water, the greater the water hardness. Hard water works against detergent, thereby causing the amount of detergent required for washing to increase. As you use more detergent, your costs for operating the dish machine will increase and the results will decrease. The solids in hard water also may build-up as a scale on wash and rinse heaters, decreasing their ability to heat water. Water temperature is important in removing soil and sanitizing dishes. If the water cannot get hot enough, your results may not be satisfactory. This is why Noble recommends that if you have installed the machine in an area with hard water, that you also install some type of water treatment equipment to help remove the dissolved solids from the water before it gets to the dish machine.

Second, hard water may have you adding drying agents to your operating cycle to prevent spotting, when the real problem is deposited solids on your ware. As the water evaporates off of the ware, the solids will be left behind to form the spotting and no amount of drying agent will prevent this. Again, using treated water will undoubtedly reduce the occurrences of this problem.

Third, treated water may not be suitable for use in other areas of your operation. For instance, coffee made with soft water may have an acid or bitter flavor. It may only be feasible to install a small treatment unit for the water going into the dish machine itself. Discuss this option with your qualified water treatment specialist.

Even after the water hardness problems have been solved, there still must be proper training of dish machine operators in how much detergent is to be used per cycle. Talk with your water treatment specialist and detergent vendor and come up with a complete training program for operators. Using too much detergent has as detrimental effects as using too little. The proper amount of detergent must be used for job. It is important to remember that certain menu items may require extra detergent by their nature and personnel need to be made aware of this. Experience in using the dish machine under a variety of conditions, along with good training in the operation of the machine, can go a long way in ensuring your dish machine operates as efficiently as possible.

Certain dish machine models require that chemicals be provided for proper operation and sanitization. Some models even require the installation of third-party chemical feeders to introduce those chemicals to the machine. Noble does not recommend or endorse any brand name of chemicals or chemical dispensing equipment. Contact your local chemical distributor for questions concerning these subjects.

Some dish machines come equipped with integral solid detergent dispensers. These dispensers are designed to accommodate detergents in a certain sized container. If you have such a unit, remember to explain this to your chemical distributor upon first contacting them.

**DETERGENT  
CONTROL  
(CONTINUED):**

As explained before, water temperature is an important factor in ensuring that your dish machine functions properly. The data plate located on each unit details what the minimum temperatures must be for either the incoming water supply, the wash tank and the rinse tank, depending on what model of dish machine you have installed. These temperatures may also be followed by temperatures that Noble recommends to ensure the highest performance from your dish machine. However, if the minimum requirements are not met, the chances are your dishes will not be clean or sanitized. Remember, a dish can look clean, but it may not be sanitized. Instruct your dish machine operators to observe the required temperatures and to report when they fall below the minimum allowed. A loss of temperature can indicate a much larger problem such as a failed heater or it could also indicate that the hot water heater for your operation is not up to capacity and a larger one may need to be installed.

There are several factors to consider when installing your dish machine to ensure that you get the best possible results from it and that it operates at peak efficiency for many years. Discuss your concerns with your local chemical distributor and water treatment specialist before there is a problem.

- PREPARATION:** Before proceeding with the start-up of the unit, verify the following:
1. The strainer is in place and is clean.
  2. That the wash and rinse arms are screwed securely into place and that their end caps are tight. The wash and rinse arms should rotate freely.
  3. Verify all chemical levels for machine chemical feeder pumps are correct.
- 

**POWER UP:** To energize the unit, turn on the power at the service breaker. The voltage should have been previously verified as being correct. If not, the voltage will have to be verified.

---

**FILLING THE WASH TUB:** For the initial fill, close the door and ensure that the MANUAL switch light is not on. Depress and hold the START CYCLE switch until the auto light comes on and then release the button. For the initial fill, run the machine through 3 cycles to fill the tub sump. The machine will run a partial cycle and fill to the bottom of the pan strainer. Open the door and verify that the water level is correct.

NOTE: For the NOBLE UH30:

Ensure the orange/white wires at the heater contactor are connected properly. They have been purposely disconnected at the factory to avoid damage to the heater element when there is no water in the booster heater.

Hereafter, the water level is controlled by the timer that has been preset at the factory. Verify that there are no other leaks on the unit before proceeding any further. The wash sump must be completely filled before operating the wash pump to prevent damage to the component. Once the wash tub is filled, the unit is ready for operation.

The machine runs a complete cycle to drain and fill. If the machine is not allowed to drain, the water will build up inside the tub. After the initial fill, the rinse water for the current cycle will become the wash water for the next cycle.

---

**WARE PREPARATION:** Proper preparation of ware will help ensure good results and less re-washes. If not done properly, ware may not come out clean and the efficiency of the dish machine will be reduced. It is important to remember that a dish machine is not a garbage disposal and that simply throwing unscraped dishes into the machine simply defeats the purpose altogether of washing the ware. Scraps should be removed from ware prior to being loaded into a rack. Pre-rinsing and pre-soaking are good ideas, especially for silverware and casserole dishes. Place cups and glasses upside down in racks so that they do not hold water during the cycle. The dish machine is meant not only to clean, but to sanitize as well, to destroy all of the bacteria that could be harmful to human beings. In order to do this, ware must be properly prepared prior to being placed in the machine.

**DAILY MACHINE PREPARATION:** Refer to the section entitled "PREPARATION" at the top of this page and follow the instructions there. Afterwards, check that all of the chemical levels are correct and/or that there is plenty of detergent available for the expected workload.

---

**WARM-UP CYCLES:** For a typical daily start-up, it is recommended to run the machine through 3 cycles to ensure that all of the cold water is out of the system and to verify that the unit is operating correctly. To cycle the machine, ensure that the power is on and that the tub has filled to the correct level.

Push the START CYCLE button and hold until the green cycle light is on and then release, the unit will start, run through the cycle, and shut off automatically. Repeat this two more times. The unit should now be ready to proceed with the washing of ware.

---

**WASHING A RACK OF WARE:** To wash a rack, open the door completely and slide the rack into the unit. Close the door, press the START CYCLE button and hold until the green cycle light is on and release, the unit will start. Once the cycle is completed, open the door and remove the rack of clean ware. Replace with a rack of soiled ware and close the door. The process will then repeat itself.

---

**OPERATIONAL INSPECTION:** Based upon usage, the pan strainer may become clogged with soil and debris as the workday progresses. Operators should regularly inspect the pan strainer to ensure it has not become clogged. If the strainer does, it will reduce the washing capability of the machine. Instruct operators to clean out the pan strainer at regular intervals or as required by work load.

---

**SHUTDOWN AND CLEANING:** At the end of the workday, close the door. Start a cycle. Wait approximately five seconds after the green cycle light comes on and then push the POWER OFF switch. This will put the machine in shutdown mode which will let the machine drain completely prior to shutting off. Once the wash tub is drained and power light is off, remove the pan strainer. Remove soil and debris from the strainer and set to the side. Unscrew the wash and rinse arms from their manifolds. Remove the end caps and flush the arms with water. Use a brush to clean out the inside of the arms. If the nozzles appear to be clogged, use a toothpick to remove the obstruction. Wipe the inside of the unit out, removing all soil and scraps. Reassemble the wash and rinse arms and replace them in the unit. The arms only need to be hand tight, do not use tools to tighten them down. Reinstall the strainer and close the door.

## **DELIMING OPERATIONS**

In order to maintain the dish machine at its optimum performance level, it will be required to remove lime and corrosion deposits on a frequent basis. A deliming solution should be available from your detergent supplier. Read and follow all instructions on the label of the deliming solution.

**NOTE:** If this machine is equipped with a HTS-11, scale prevention and corrosion control device, and lime is becoming a frequent problem, the cartridge needs to be replaced. To order a replacement cartridge, call Noble immediately to have one shipped to you.

To proceed with the deliming operation, fill the dish machine and add the correct amount of deliming solution as recommended by the deliming solution manufacturer. The water capacity of the tank can be verified on the specification sheet (s) of this manual.

Perform the following operations to delime the dish machine:

1. Push Manual Switch on the front of the control panel.
2. Close the door (after adding the deliming solution).
3. Run the machine for the recommended period of time.
4. Press the Power Switch to turn the unit off and open the door.
5. Wait five minutes, then inspect the inside of the machine. If the machine is not delimed, run another time cycle as per the deliming solution's instructions.
6. When clean, drain and re-fill the machine.
7. Run in MANUAL for 10 minutes to remove residual deliming solution.
8. Drain and re-fill the machine.

**PREVENTATIVE MAINTENANCE:**

The dish machines covered in this manual are designed to operate with a minimum of interaction with the operator. However, this does not mean that some items will not wear out in time. Noble highly recommends that any maintenance and repairs not specifically discussed in this manual should be performed by **QUALIFIED SERVICE PERSONNEL ONLY**. Performing maintenance on your dish machine may void your warranty if it is still in effect.

There are many things that operators can do to prevent catastrophic damage to the dish machine. One of the major causes of component failure has to do with pre-scrapping procedures. A dish machine is not a garbage disposal; any large pieces of material that are put into the machine shall remain in the machine until they are either broken up (after spreading out on your ware!) or physically removed. Strainers are installed to help catch debris, but they do no good if they are clogged. Have operators regularly inspect the pan strainers to ensure (1) that they are free of soil and debris and (2) they are laying flat in the tub.

When cleaning out strainers, do NOT beat them on waste cans. The strainers are made of metal and can be forgiving; but once severe damage is done, it is next to impossible for the strainer to work in the way it was designed to. Wipe out strainers with a rag and rinse under a faucet if necessary. For stubborn debris, a toothpick should be able to dislodge any obstructions from the perforations. Always ensure that strainers are placed back in the machine before operation and that they lay flat in the tub.

You may wish to also refer to the page entitled "Detergent Control" in order to learn more about how your water hardness will effect the performance of your machine. Hard water makes dish machines work harder and decreases efficiency.

Again, it is important to remind operators that trying to perform corrective maintenance on the dish machine could lead to larger problems or even cause harm to the operator. If a problem is discovered; secure the dish machine using proper shut down procedures as listed in this manual and contact a **QUALIFIED SERVICE AGENCY**.

Some problems, however, may having nothing to do with the machine itself and no amount of preventative maintenance is going to help. A common problem has to do with temperatures being too low. Verify that the water temperatures coming to your dish machine match the requirements listed on the machine data plate. There can be a variety of reasons why your water temperature could be too low and you should discuss it with a **QUALIFIED SERVICE AGENCY** to determine what can be done.

By following the operating and cleaning instructions in this manual, you should get the most efficient results from our machine. As a reminder, here are some steps to take to ensure that you are using the dish machine the way it was designed to work:

## **PREVENTATIVE MAINTENANCE (CONTINUED):**

1. Ensure that the water temperatures match those listed on the machine data plate.
2. Ensure that all strainers are in place before operating the machine.
3. Ensure that all wash and/or rinse arms are secure in the machine before operating.
4. Ensure that drains are closed/sealed before operating.
5. Remove as much soil from dishes by hand as possible before loading into racks.
6. Do not overfill racks.
7. Ensure that glasses are placed upside down in the rack.
8. Ensure that all chemicals being injected to machine have been verified as being at the correct concentrations.
9. Clean out the machine at the end of every workday as per the instructions in the manual.
10. Always contact a QUALIFIED SERVICE AGENCY whenever a serious problem arises.
11. Follow all safety procedures, whether listed in this manual or put forth by local, state or national codes/regulations.

**WARNING:** Inspection, testing and repair of electrical equipment should be performed only by qualified service personnel. Certain procedures in this section require electrical tests or measurements while power is applied to the machine.

**EXERCISE EXTREME CAUTION AT ALL TIMES.**

If test points are not easily accessible, disconnect power, attach test equipment and reapply power to test. When replacing electrical parts, disconnect power at source circuit breaker.

<b>PROBLEM</b>	<b>POSSIBLE CAUSE</b>	<b>REMEDY</b>
Water overflow from bottom of door.	<ol style="list-style-type: none"> <li>1. Clogged drain.</li> <li>2. Machine not level.</li> <li>3. Excessive inlet pressure.</li> <li>4. Detergent foaming</li> </ol>	<ol style="list-style-type: none"> <li>1. Remove obstruction.</li> <li>2. Level machine, or increase height to the front.</li> <li>3. Install pressure reducing valve, or adjust if one is present. Ensure flow is 20 ±5 PSI.</li> <li>4. Reduce detergent quantity.</li> </ol>
Wash motor doesn't operate on manual wash.	<ol style="list-style-type: none"> <li>1. Loose or broken wires.</li> <li>2. Defective manual wash switch</li> <li>3. Defective motor starting relay.</li> </ol>	<ol style="list-style-type: none"> <li>1. Reconnect or replace wires in motor.</li> <li>2. Replace.</li> <li>3. Replace.</li> </ol>
Motor operates on manual wash but not on automatic.	<ol style="list-style-type: none"> <li>1. Defective circuit in manual wash switch.</li> </ol>	<ol style="list-style-type: none"> <li>1. Replace switch.</li> </ol>
No water comes through the rinse arms when the "ON/FILL" switch is depressed.	<ol style="list-style-type: none"> <li>1. Water not turned on.</li> <li>2. Defective solenoid valve.</li> </ol>	<ol style="list-style-type: none"> <li>1. Turn water on.</li> <li>2. Replace solenoid valve.</li> </ol>
Little or no water coming through the rinse assemblies.	<ol style="list-style-type: none"> <li>1. Limed up rinse heads or piping.</li> <li>2. Low water pressure.</li> </ol>	<ol style="list-style-type: none"> <li>1. Delime rinse heads.</li> <li>2. Increase pipe size to machine. Adjust pressure regulator.</li> </ol>



**WARNING:** Inspection, testing and repair of electrical equipment should be performed only by qualified service personnel. Certain procedures in this section require electrical tests or measurements while power is applied to the machine.

**EXERCISE EXTREME CAUTION AT ALL TIMES.**

If test points are not easily accessible, disconnect power, attach test equipment and reapply power to test. When replacing electrical parts, disconnect power at source circuit breaker.

PROBLEM	POSSIBLE CAUSE	REMEDY
Rinse water runs continuously with breaker turned off.	<ol style="list-style-type: none"> <li>1. Defective plunger in solenoid valve.</li> <li>2. Defective diaphragm in solenoid valve.</li> </ol>	<ol style="list-style-type: none"> <li>1. Delime rinse heads.</li> <li>2. Replace diaphragm.</li> </ol>
Wash temperature not at required reading on thermometer.	<ol style="list-style-type: none"> <li>1. Check that orange/white wires are connected.</li> <li>2. Defective thermometer.</li> <li>3. Defective thermostat.</li> </ol>	<ol style="list-style-type: none"> <li>1. See note on page 7.</li> <li>2. Replace.</li> <li>3. Adjust thermostat. Replace thermostat.</li> </ol>
Rinse water not at required temperature range.	<ol style="list-style-type: none"> <li>1. Check that orange/white wires are connected.</li> <li>2. Thermometer is defective</li> <li>3. Thermostat is defective.</li> <li>4. Incoming rinse water does not meet minimum criteria indicated on machine data plate.</li> </ol>	<ol style="list-style-type: none"> <li>1. See note in installation instructions.</li> <li>2. Replace.</li> <li>3. Adjust the thermostat. Replace if necessary.</li> <li>4. Adjust as required.</li> </ol>
Machine doesn't drain when "OFF/DRAIN" switch is pressed.	<ol style="list-style-type: none"> <li>1. Drain solenoid clogged.</li> <li>2. Defective motor or motor start relay.</li> <li>3. Defective drain valve.</li> </ol>	<ol style="list-style-type: none"> <li>1. Remove obstruction.</li> <li>2. Replace.</li> <li>3. Replace.</li> </ol>
No indication of pressure.	<ol style="list-style-type: none"> <li>1. Water turned off.</li> <li>2. Pressure gauge defective.</li> </ol>	<ol style="list-style-type: none"> <li>1. Turn water on.</li> <li>2. Replace pressure gauge.</li> </ol>

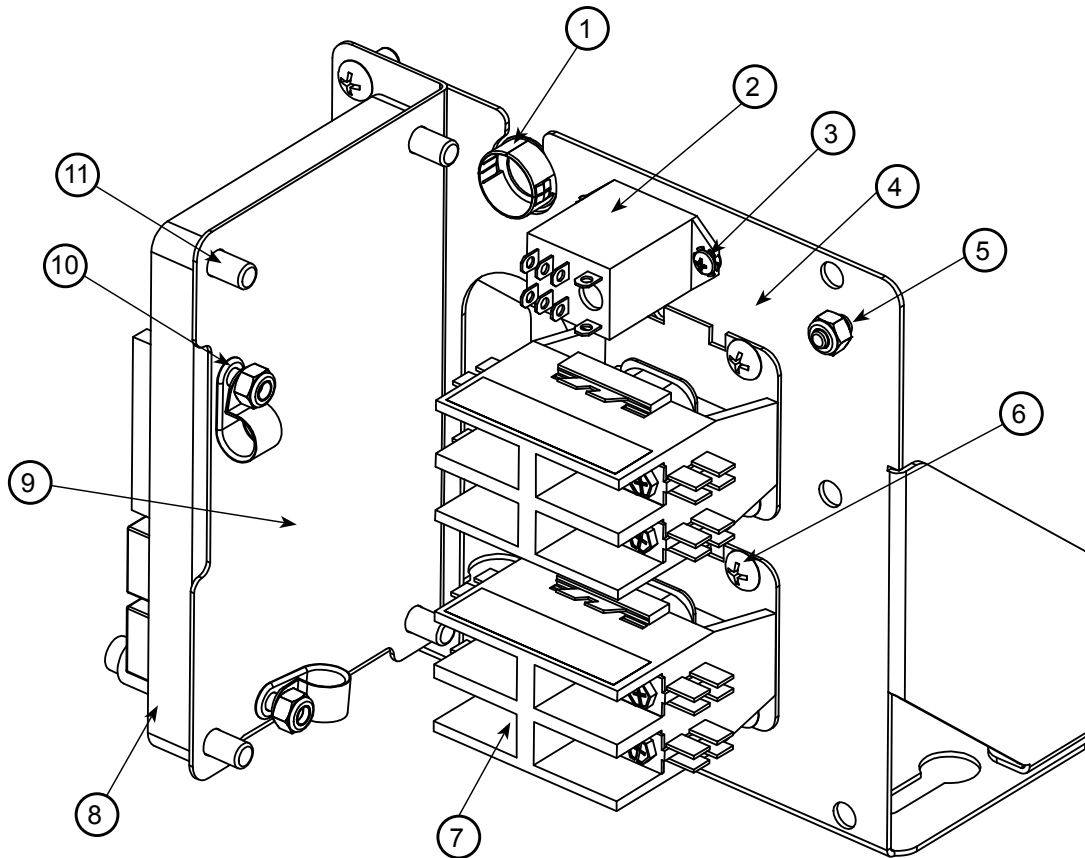

ITEM	QTY	DESCRIPTION	PART NUMBER
1	1	Heyco Open/Closed Busing .875	5975-003-35-21
2	1	Relay, Omron	05945-111-89-75
3	2	Screw, 6-32 X 3/8	05305-002-25-91
4	1	Control Panel Weldment	05700-003-31-48
5	3	Locknut, Nylon	05310-373-01-00
6	8	Screw, 10-32 X 3/8	05305-173-12-00
7	2	Contactors, 240V	05945-002-74-20
8	1	Universal Timer	05945-003-33-09
	1	Fused Universal Timer (not shown)	05945-003-75-23
9	1	Timer Mounting Bracket (Avenger HT Only)	05700-003-36-05
10	1	P Clamp 1/4"	05975-002-61-42
	1	Locknut. 6-32 w/ Nylon Insert	05310-373-03-00
11	4	Screw, 10-32 X 1	05305-002-19-42

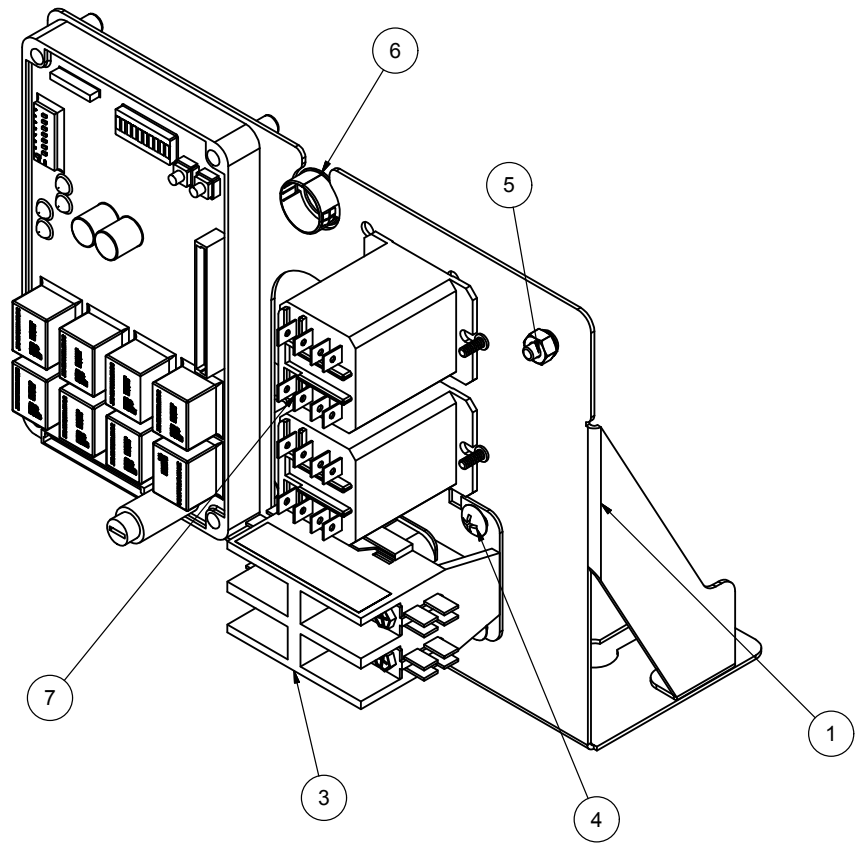

ITEM	QTY	DESCRIPTION	PART NUMBER
1	1	W- Control Panel LT with Heater	05700-003-45-73
2	1	Timer, Universal Polytron	05945-003-33-09
3	2	Contactator, 115V, 30A	05945-109-05-69
4	1	Screw, 10-32 3/8" Long Phil Truss	05700-003-31-48
5	3	Locknut, 10 -24 S/S Hex w/ Nylon Ins.	05305-173-12-00
6	8	Heyco Open/Closed Busing .875	5975-003-35-21
7	2	Relay, 20A	5945-002-90-51

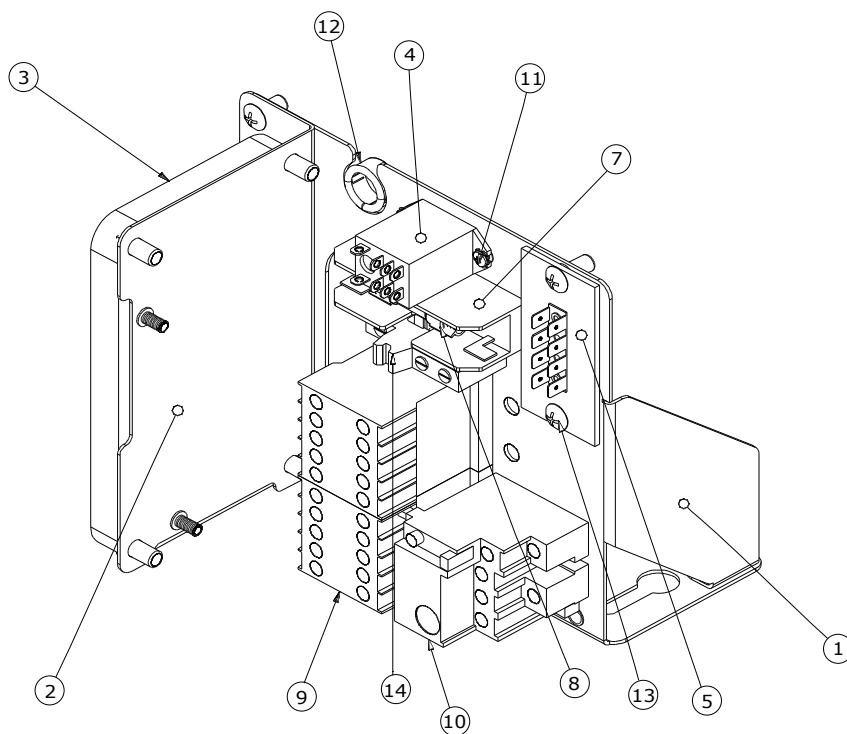

ITEM	QTY	DESCRIPTION	PART NUMBER
1	1	Electrical Panel Weldment	05700-003-37-46
2	1	Timer, Bracket Assembly	05700-003-36-05
3	1	Timer, Universal	05945-003-33-09
	1	Fused Universal Timer (Alternate Construction)	05945-003-75-23
	1	Fuse	05920-003-75-24
	1	9 Wire Harness	05999-003-75-81
	1	10 Wire Harness	05999-003-87-88
4	1	Relay	05945-002-47-41
5	1	Terminal Board	05940-021-94-85
6	1	Track, Terminal Block	05700-003-37-49
7	1	Fuse Holder	05920-011-72-89
8	1	Fuse, 1/4 Amp	05920-002-75-95
9	2	Contactor	05945-111-60-07
10	1	Overload	05945-111-60-08
11	2	Screw, 6-32 X 3/8" w/ External T Washer	05305-002-25-91
12	1	Open/Closed Bushing, 7/8"	05975-003-35-21
13	6	Screw ,10-32 X 3/8" Long Phil Truss Head	05305-173-12-00
14	2	End Clamp	05950-111-60-30
15	1	Transformer ( not shown)	05950-011-50-70

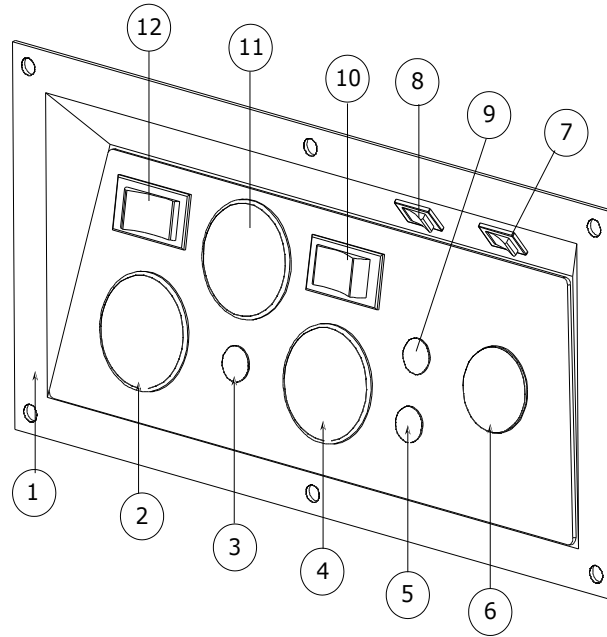

ITEM	QTY	DESCRIPTION	PART NUMBER
1	1	Control Panel	09330-003-31-66
	1	Decal, Control Panel	09905-003-31-65
	6	Locknut, 1/4" -20 S/S Hex w/ Nylon Insert	05310-374-01-00
2	1	Thermometer, 48" Rinse	06685-111-68-48
3	1	Light, Amber	05945-111-44-44
4	1	Thermometer, 96" Wash	06685-111-68-49
5	1	Light, Red	05945-111-44-45
6	1	Window Plug	05975-003-31-72
7	1	Switch, Rinse Aid	05930-011-49-54
8	1	Switch, Detergent	05930-011-49-54
9	1	Light, Green	05945-111-44-43
10	1	Switch, On-Off	05930-301-49-00
11	1	Gauge, 0-100 PSI w/ Green Zone	06680-011-86-42
	1	Bell Adapter, 1/4 NPT X 1/8 FNPT	04730-003-33-02
	1	Hose, Pressure Gauge	04730-003-33-02
12	1	Switch, Auto-Manual	05930-011-49-55
	1	Kick Plate Weldment (not shown)	05700-003-32-91
	1	Complete Control Panel Assembly	05700-003-31-64
	1	Wire Harness	05999-003-34-61

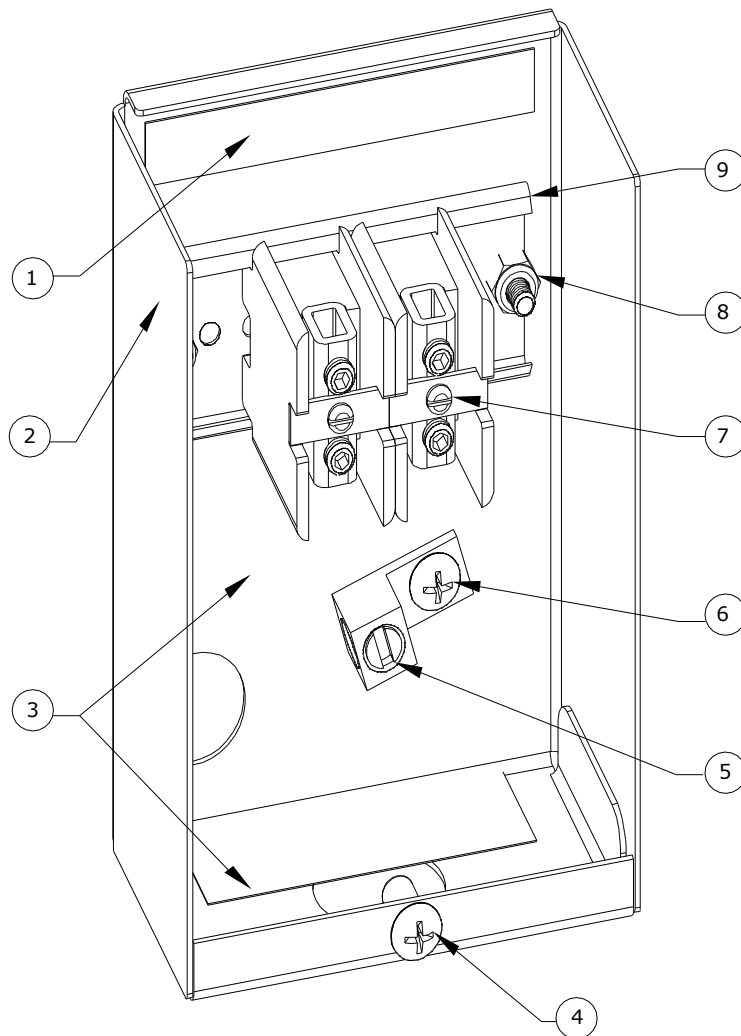

ITEM	QTY	DESCRIPTION	PART NUMBER
1	1	Decal. Power Connections	09905-011-47-35
2	1	Terminal Block Box	05700-003-27-69
	1	Terminal Box Cover (not shown)	05700-003-27-70
3	1	Decal, Copper Conductors	09905-001-62-72
4	1	Screw, 1--32 X 1/2"	05305-011-39-36
5	1	Ground Lug	05940-200-76-00
6	1	Screw, 1--32 X 1/2"	05305-011-39-36
7	2 (3 per 480V)	Terminal Block	05940-500-02-19
8	1	Locknut, 10-24 S/S Hex w/ Nylon Insert	05310-373-01-00
9	1	Terminal Block Track	05700-000-43-60

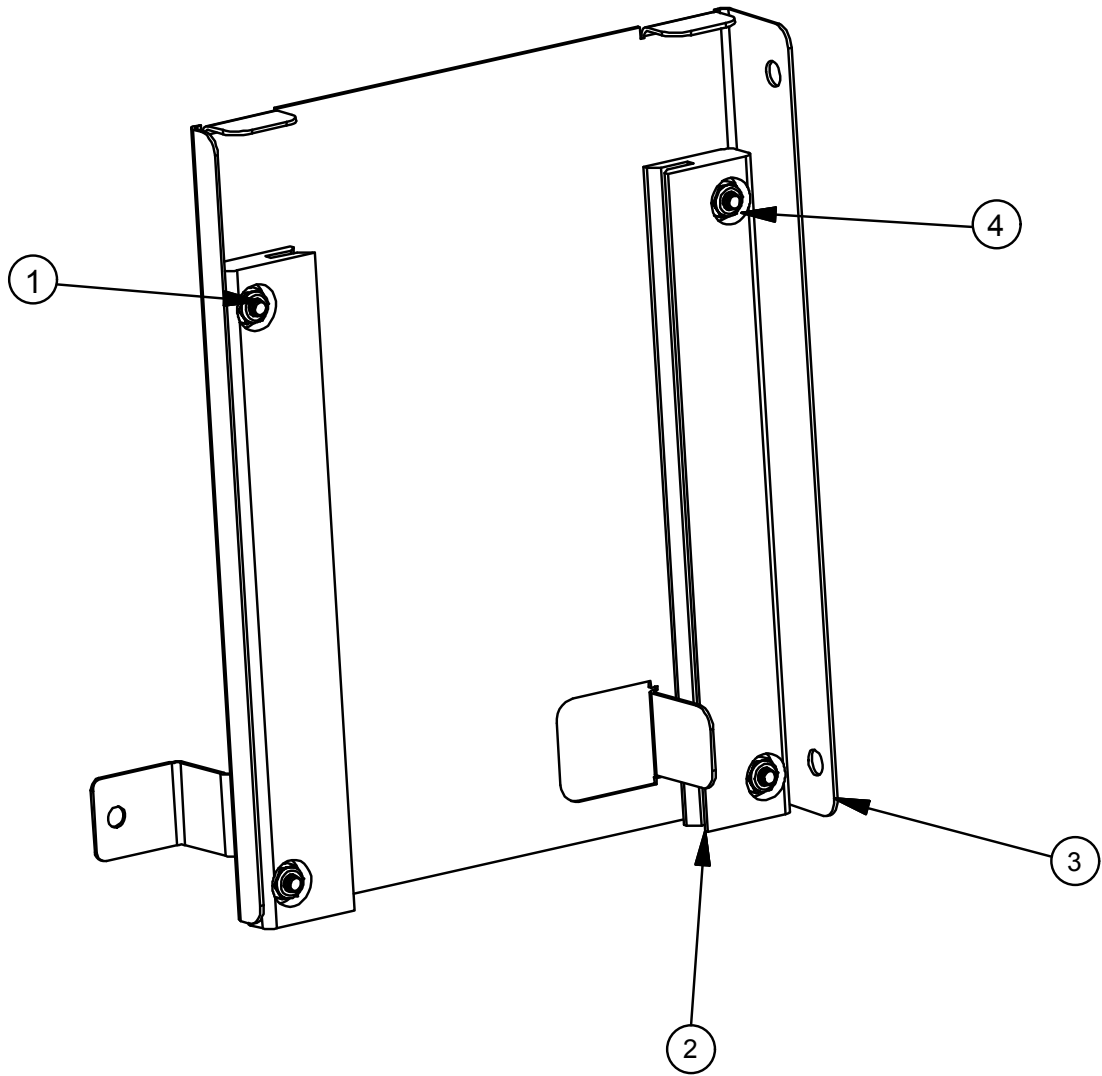

ITEM	QTY	DESCRIPTION	PART NUMBER
1	4	Screw, 10-32 X 5/8" PH Truss HD	05305-003-02-12
2	2	Track, Peripump HT	05700-003-33-44
3	1	A-Track Mount HT	05700-003-33-52
4	4	Locknut, 10-32 With Nylon Insert	05310-373-02-00

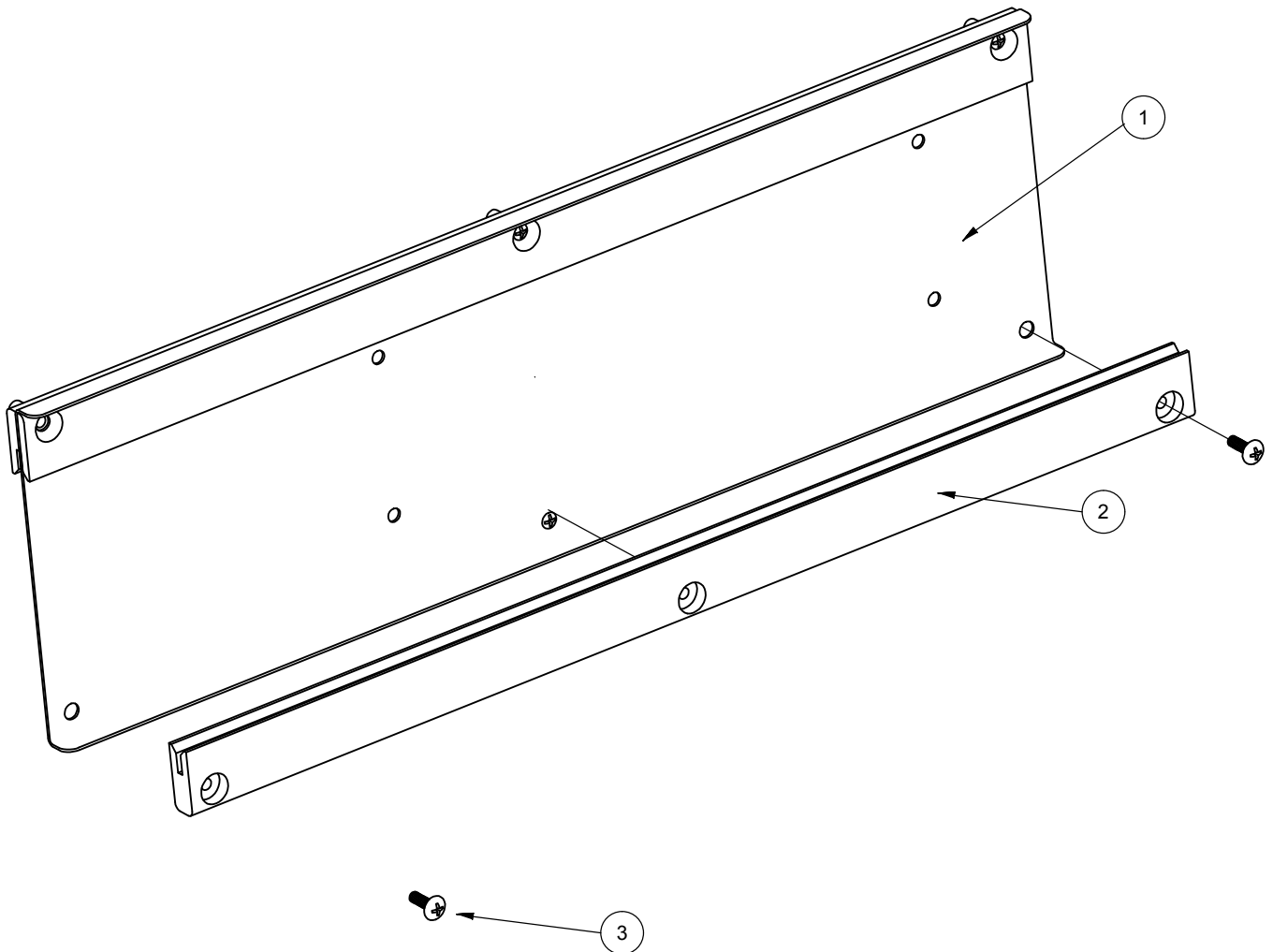

ITEM	QTY	DESCRIPTION	PART NUMBER
1	1	Complete Noble UL30 Peripump Track Assembly	05700-003-33-31
2	1	Bracket, Track Mounting	05700-003-33-30
3	2	Track, Peripump	05700-003-33-29
4	6	Screw, 10-32 X 5/8" Truss Head	05305-003-02-12



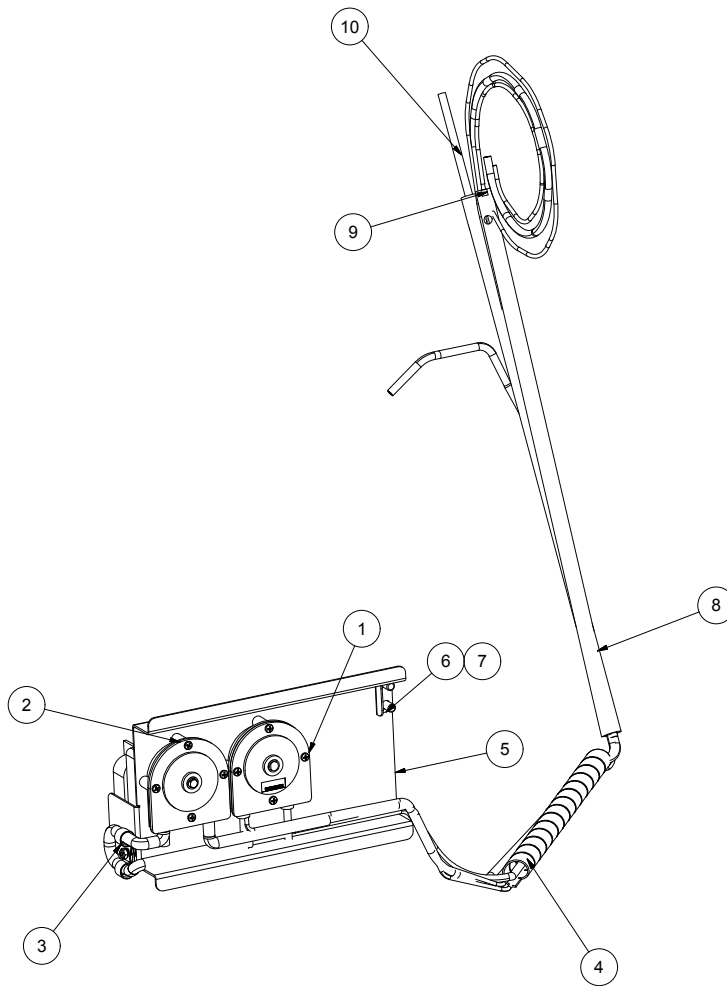

ITEM	QTY	DESCRIPTION	PART NUMBER
1	1	A-Peri Pump, 14 RPM	05700-002-72-82
2	1	A-Peri Pump, 36 PRM 240V/Red Tygoprene	05700-003-78-74
3	2	Strap, Nylon Loop	04320-002-71-22
4	1	CW 750 PE UV Black 8924 12"	05700-003-33-63
5	1	W Peripump Slide	05700-003-33-48
6	1	A-Stop Bracket	05700-003-36-24
7	2	Screw, 10-32 X 3/8" Long Phil Truss	05305-173-12-00
8	2	Tube Stiffener	05700-003-33-60
9	1	Tie, 4" PLT 1-M Panduit Cable	05700-003-33-58
10	1	A-Tube, Blue 1/4 X 22" Polyethylene	05700-011-86-78

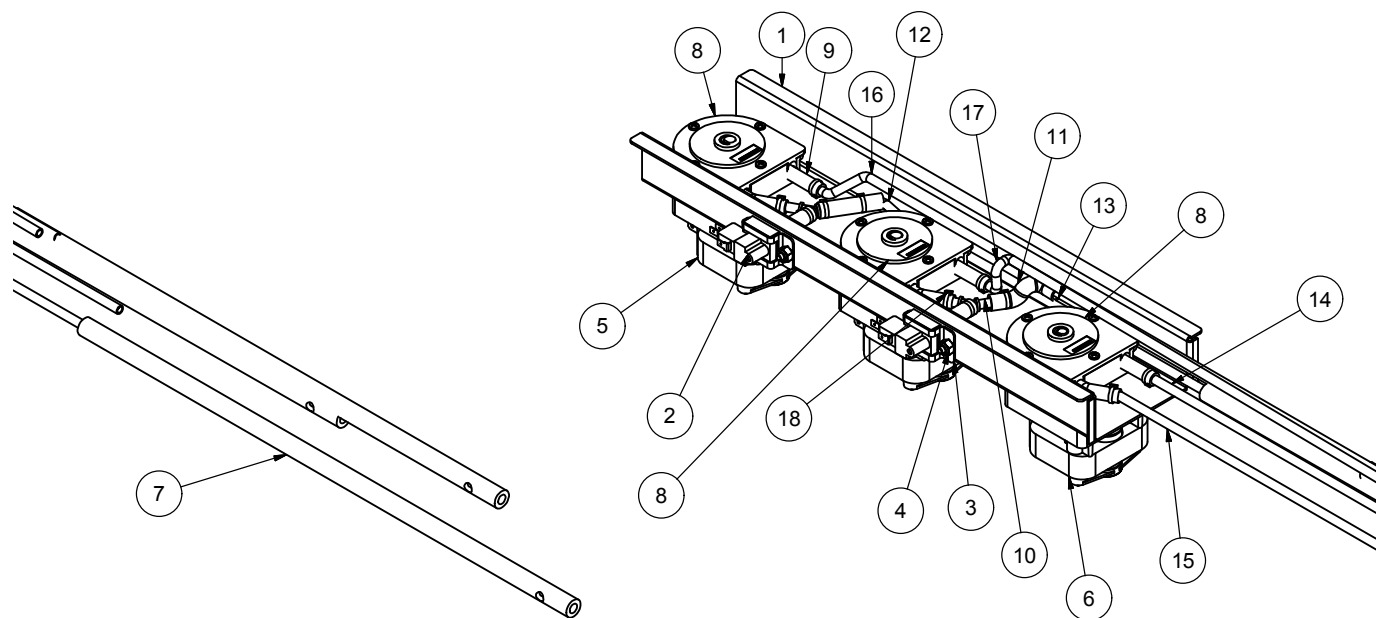

ITEM	QTY	DESCRIPTION	PART NUMBER
1	1	W-Peri Pump Channel	05700-003-53-25
2		Swtich, Vaccum	06685-003-36-13
3		F-Pressure Swtich Bracket	05700-003-53-03
4		Lockenut, 10-24 S/S Hex W/ Nylon Inserts	05310-373-01-00
5		Motor, 105-3036-2 36 RPM	04320-111-35-14
6		Motor, 14 RPM Peri Pump	04320-111-35-13
7		A-Kit, Peri Pump Assy W/ White Roller	04320-002-83-90
8		Tube Stiffener	05700-002-66-49
9		Tube, Tygoprene XL60 3/16 X 8 9657-25	05700-003-22-89
10		Wye, 1/4" Barbed PVDF	04730-003-36-14
11		Tubing, Clear 5/16 ID	04710-003-53-26
12		A-Tubing, 1/4 X 100 Red	05700-003-03-45
13		A-Tubing, 1/4 X 100 Long White	05700-003-20-67
14		A-Tube, 1/4 OD X 48 Blue Plastic	05700-002-62-11
15		A-Tubing, 1/4 X 100 Long Blue	05700-003-20-68
16		A-Tube, 1/4 OD X 48 Red Plastic	05700-002-62-12
17		A-Tubing, 1/4 X 48 White Plastic	05700-002-62-13
18		Tie, 4" PLT1M-M Panduit Cable	05945-602-01-16

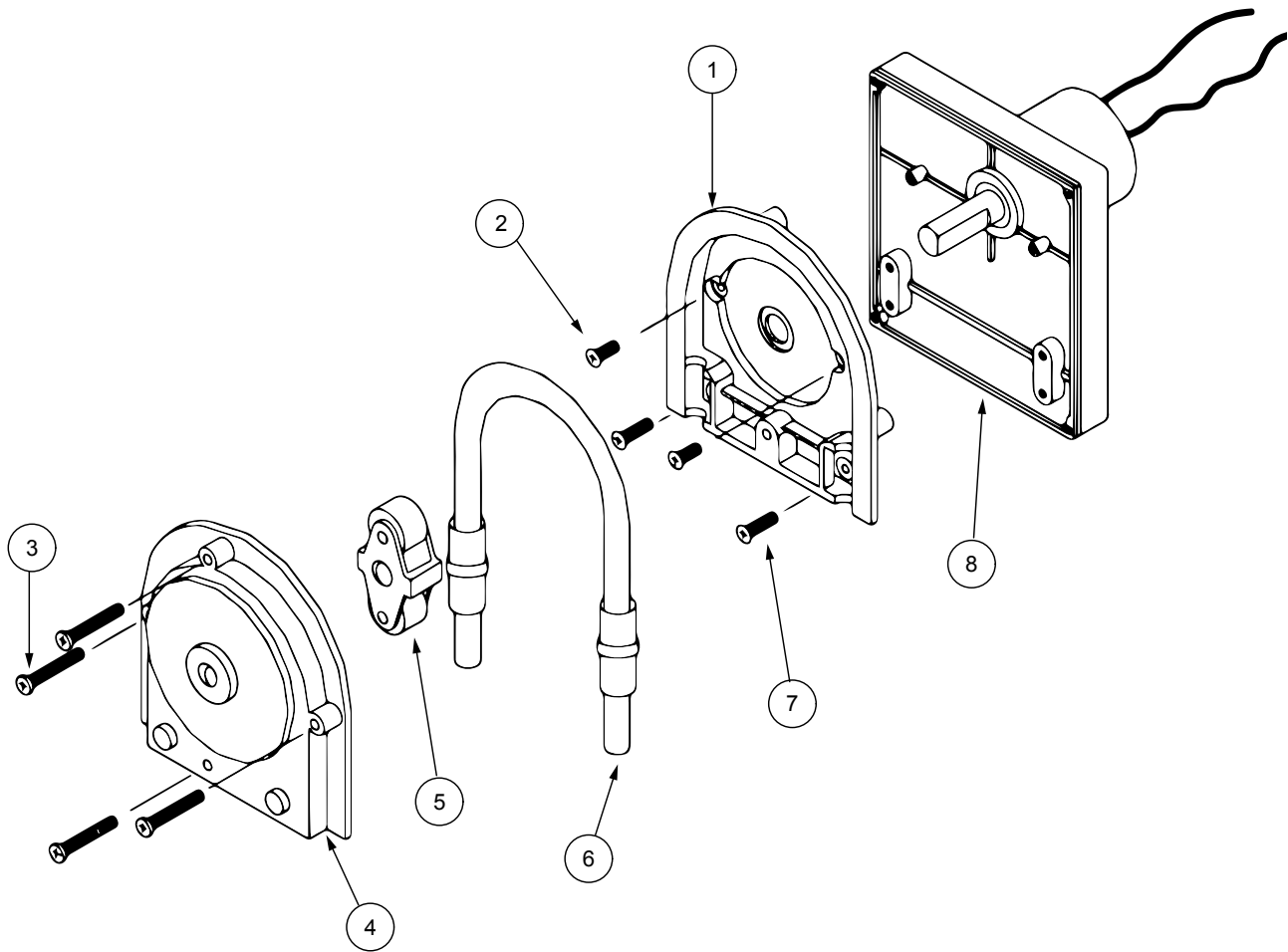

ITEM	QTY	DESCRIPTION	PART NUMBER
1	1	Rear Housing	04320-111-37-09
2	2	Screw, 8-32 X 3/8" Phillips Pan Head	05305-011-37-07
3	4	Screw, 6-32 X 32 X 3/4" Phillips Pan Head	05305-011-37-05
4	1	Front Housing	04320-111-37-08
5	1	Roller, Black	04320-111-65-27
	1	Roller, White	04320-002-82-28
6	1	Tygoprene Tube	05700-03-22-89
7	2	Screw, 8-32 X 1/2" Phillips Flat Head	05305-011-37-06
8	1	Motor, 14 RPM 115V Rinse Aid Feeder Pump	04320-111-35-13
		Motor, 14 RPM 240V Rinse Aid Feeder Pump	04320-111-47-46
		Motor, 36 RPM 115V Detergent/Sanitizer Feeder Pump	04320-111-35-14
		Motor, 36 RPM 240V Detergent/Sanitizer Feeder Pump	04320-111-47-47

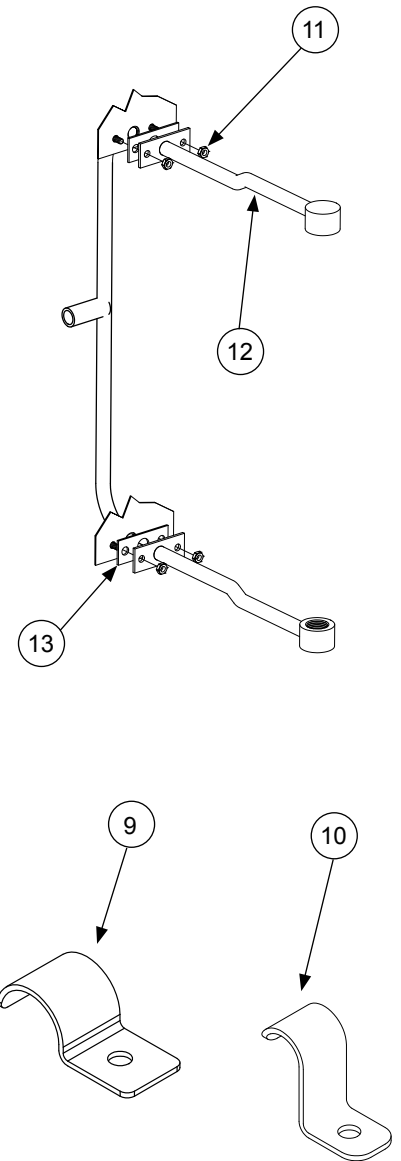
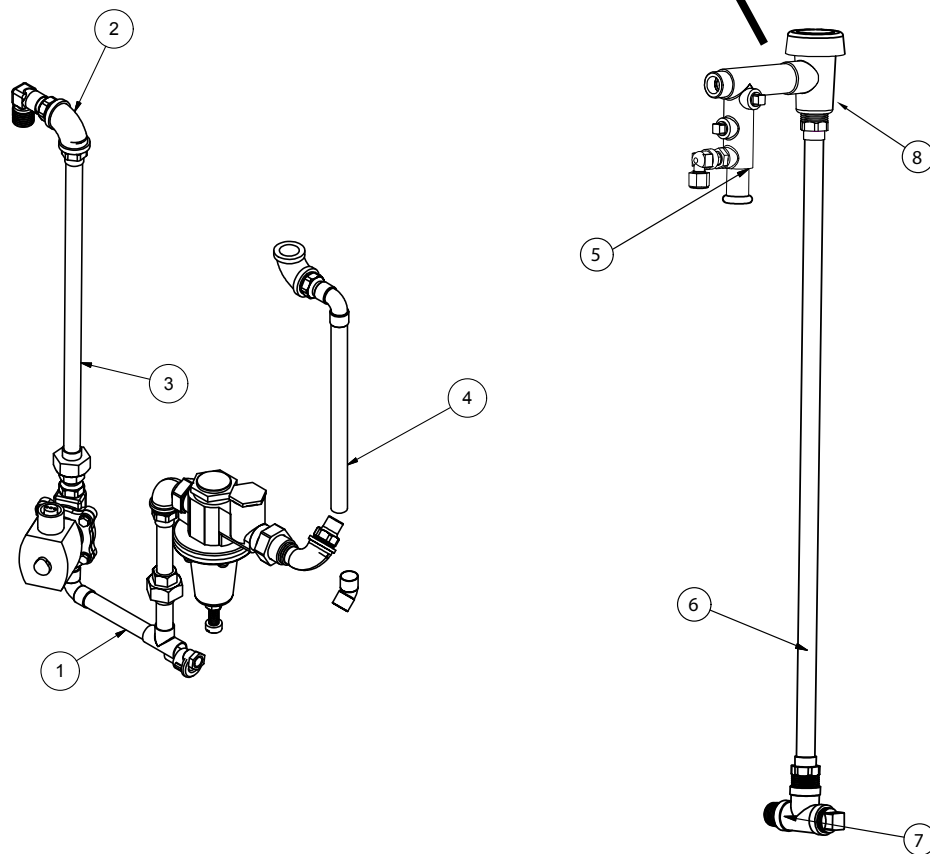
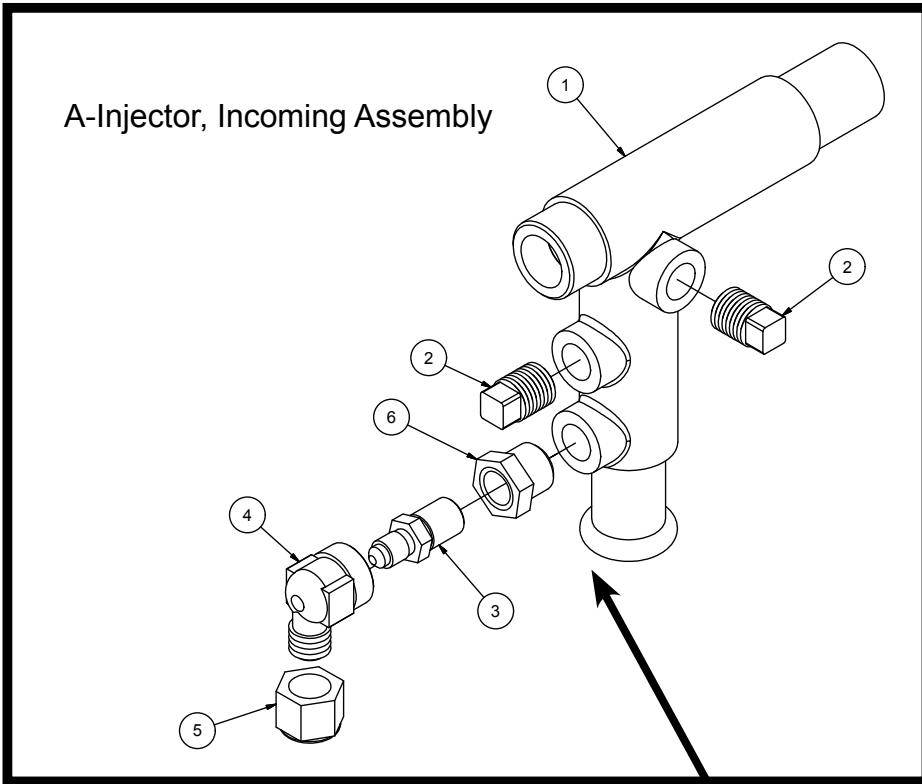

### A-INJECTOR, INCOMING ASSEMBLY

ITEM	QTY	DESCRIPTION	PART NUMBER
1	1	W-Weld, Injector Machined	05700-031-41-83
2	2	Plug, 1/4 211 P-4 Brass	04730-209-01-00
3	1	Valve, Check	04820-111-51-14
4	1	Ftg, Outlet Elbow (ECO9218-8044)	04820-111-51-18
5	1	Nut, Tube 1/8PP Jaco P-0-2-SPEC Ecolab #92008002	04730-011-59-45
6	1	Bushing, 1/4 X 1/8 Stainless	04730-003-05-61

**NOTE:**  
USE TEFLON TAPE ON THREADS, DO NOT USE PIPE DOPE

### PLUMBING ASSEMBLIES

ITEM	QTY	DESCRIPTION	PART NUMBER
1	1	1/2 " Plumbing Section	05700-003-32-17
2	1	A-Plumbing, Inlet Booter	05700-003-33-97
3	1	A-Plumbing, Inlet Vavle-Booster	05700-003-33-98
4	1	A-Plumbing, Inlet Hook-Up	05700-003-33-99
5	1	A-Injector, Incoming Assembly	05700-003-22-01
6	1	Assy, Noble UH30 Vaccum Break	05700-003-32-15
7	1	Vac BRKR 1/2 Brass Bon.EDP-0336402	04820-003-06-13
8	1	Nipple-1/2 Close Brass	04730-207-15-00
9	2	Clamp, Pipe	05700-000-35-05
10	1	Clamp, Pipe	05700-011-38-62
11	2	Lock Nut 1/4-20 S/S	05310-374-01-00
12	2	Rinse Hub Weldment	05700-021-38-31
13	2	Rinse Gasket	05330-111-42-81

**RINSE SOLENOID VALVE & VACUUM BREAKER REPAIR PARTS KIT/WATER HAMMER KIT OPTION**

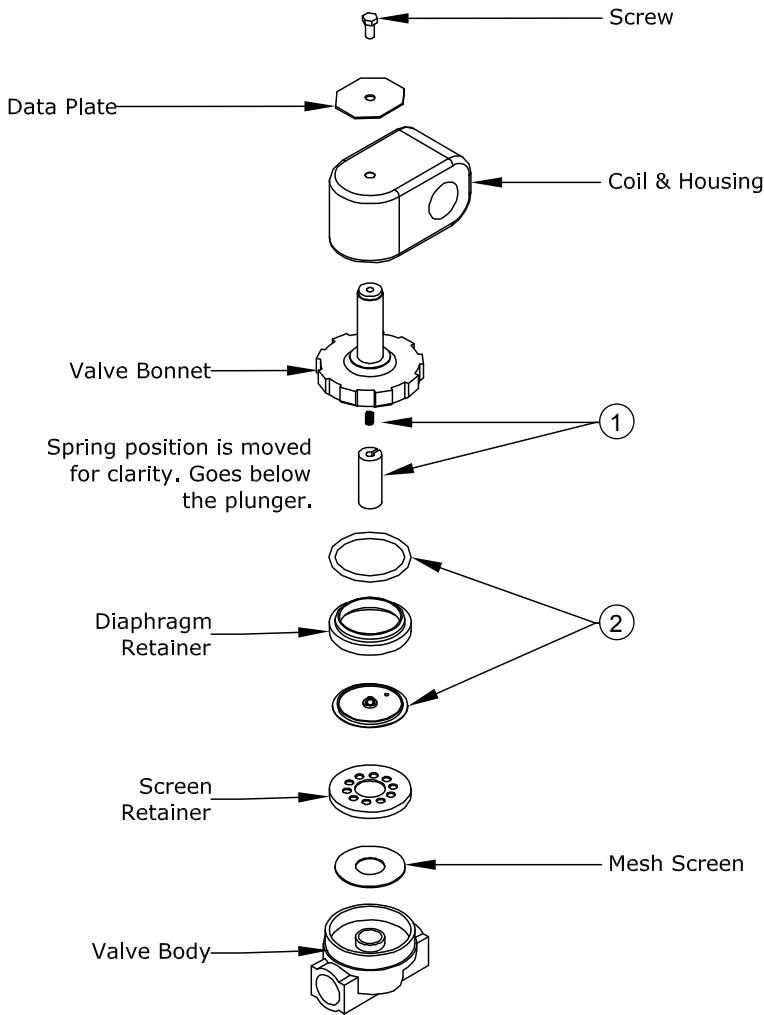

**Solenoid Valve Assembly**

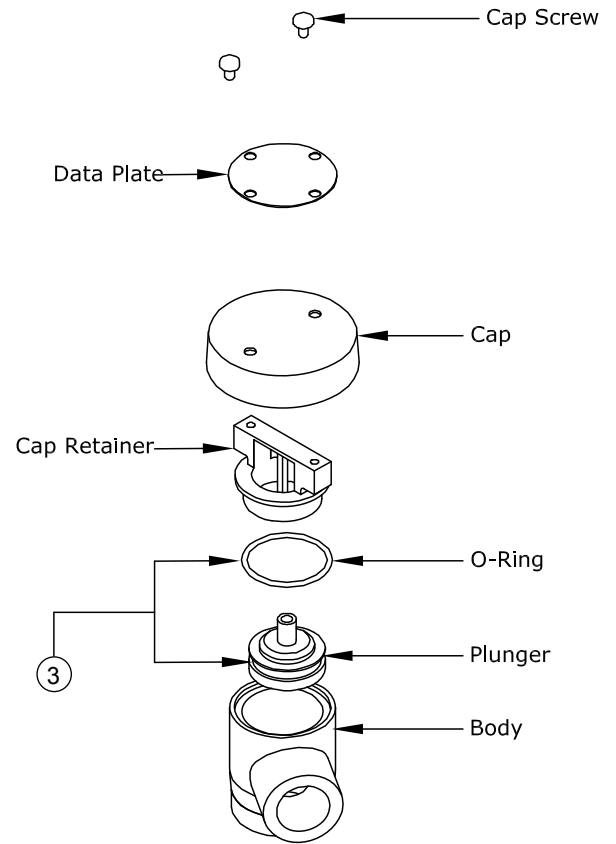

**Complete Vacuum Breaker Assembly**

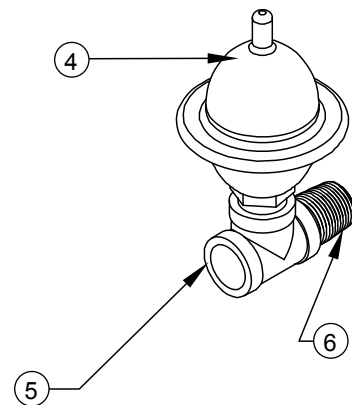

### RINSE SOLENOID VALVE & VACUUM BREAKER REPAIR PARTS KIT/WATER HAMMER KIT OPTION

ITEM	QTY	DESCRIPTION	PART NUMBER
		Complete 110 Volt Solenoid Valve Assembly 1/2" Assembly	04810-100-12-18
		Coil & Housing Only 1/2"	06401-003-07-43
		Complete 220 Volt Solenoid Valve Assembly 1/2" Assembly	04810-003-07-43
		Coil & Housing Only 1/2"	06401-003-07-43
1	1	Spring & Plunger Kit	06401-003-07-41
2	1	O-Ring & Diaphragm	06401-003-07-41
3	1	Components of Repair Kit	06401-003-06-23
		Complete Vacuum Breaker Assembly 1/2" NPT	04820-003-06-13
4		Water Hammer Arrestor	05700-002-64-67
5	1	Tee 1/2" X 1/2" 1/2"	04730-211-27-00
6	1	Close Nipple 1/2" NPT	04730-207-15-00

**WASH MOTOR/DRAIN PLUMBING/NOBLE UL30 WASH MANIFOLD ASSEMBLY**

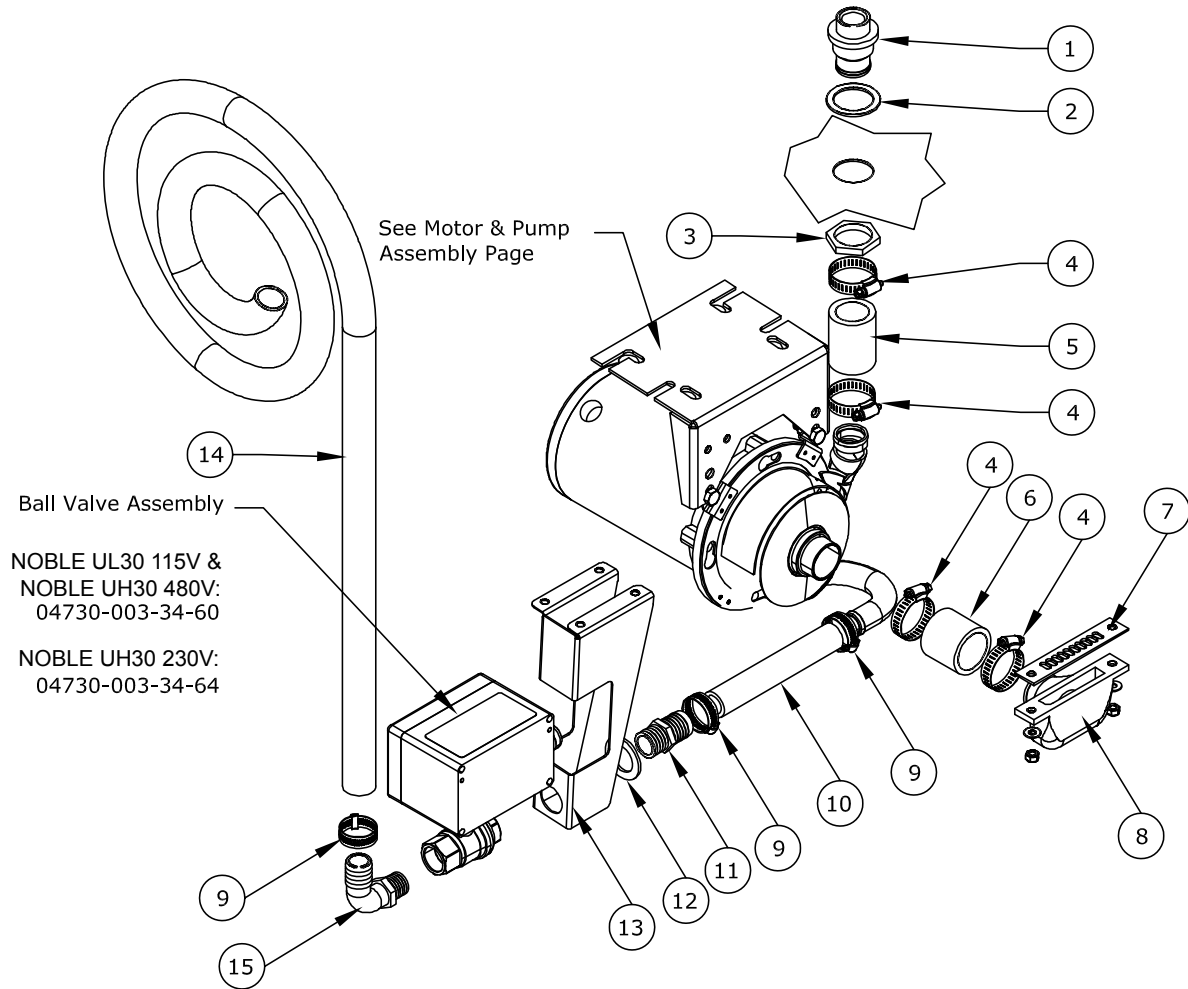
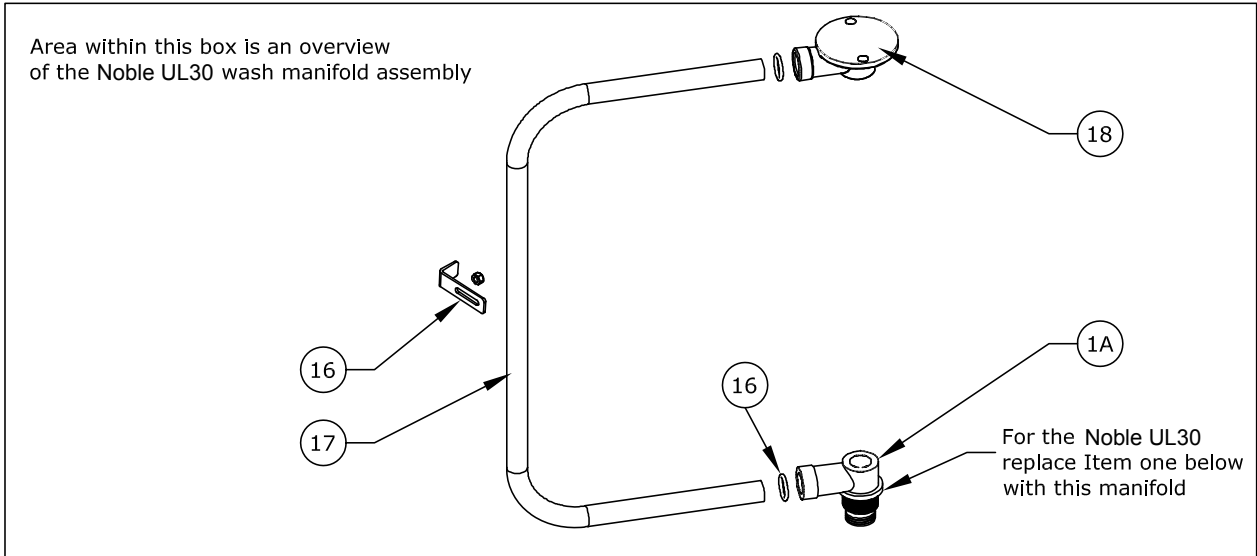



### WASH MOTOR/DRAIN PLUMBING/NOBLE UL30 WASH MANIFOLD ASSEMBLY

ITEM	QTY	DESCRIPTION	PART NUMBER
1	1	Hub, Discharge Machine (Noble UH30 Shown)	05700-021-37-90
1A	1	Lower, Wash Manifold (Noble UL30)	05700-021-52-80
2	1	Gasket, Manifold	05330-200-23-00
3	1	Nut, Jam 1-1/2" -12 NPT	05700-000-86-23
4	4	Hose Clamp, 1-5/16"-2 1/4" #28	04730-719-01-37
5		Hose, 1-1/4" X 2-1/4" Reinforced	05700-011-44-48
6	1	Hose, Bottom Manifold Pump	05700-001-22-92
7		Gasket, Suction Adaptor	05330-003-32-82
8	1 2 3	Casting, Suction Adaptor Washer, S/S 1/4"-20 I.D. Locknut, 1/4"-20 S/S	09515-031-39-86 05311-174-01-00 05310-374-01-00
9		Clamp, 3/16" to 1-1/2"	04730-719-06-09
10		Hose, 8" Straight Drain	04720-003-27-95
11		Hosebarb, 1" X 3/4" NPT Polypropylene	04730-011-65-86
12		Spacer, Drain Valve	05700-003-31-93
13		Bracket, Drain Valve Support	05700-003-31-74
14		Hose, 1" I.D. X Ten Feet Long	05700-011-39-72
15		Hosebarb, 90 Degree 1" X 3/4" NPT	04730-011-65-87
16		O-Ring, Manifold	05330-111-35-15
17		Tube, Wash Manifold	05700-002-13-75
18		Upper Wash Manifold	05700-031-34-82
19		Bracket, Manifold Tube Positioning Locknut 1/4"-20 S/S	05700-011-34-63 05310-374-01-00

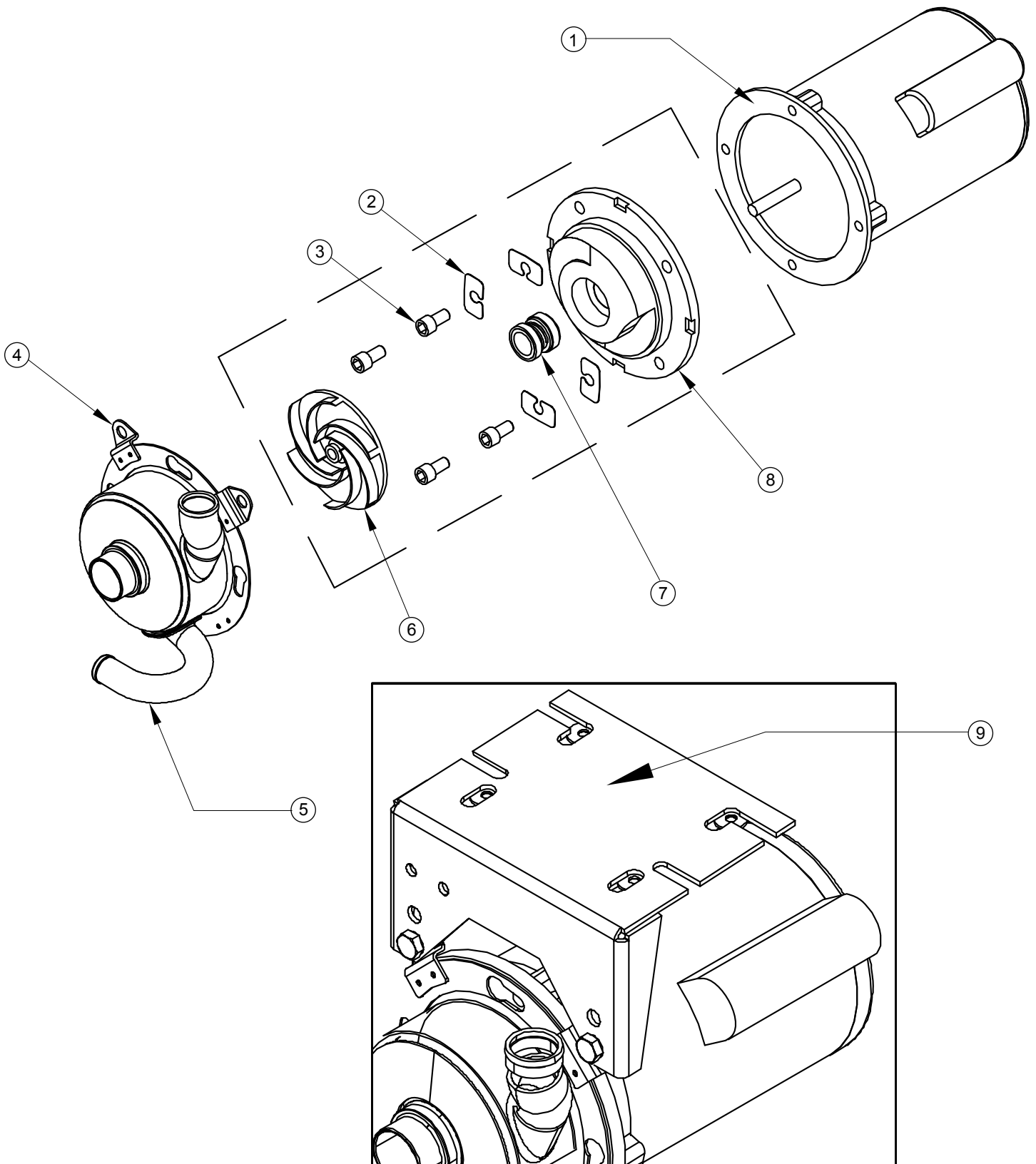

ITEM	QTY	DESCRIPTION	PART NUMBER
		Complete Pump & Motor Assembly, 60 HZ Bracket	05700-003-31-57
		Complete Pump & Motor Assembly, 480V, 60 HZ Bracket	05700-003-52-80
		Complete Pump & Motor Assembly, 60 HZ No Bracket	06105-002-72-75
		Complete Pump & Motor Assembly, 480V, 60 HZ No Bracket	06105-003-52-78
		Pump Only Assembly, 60 HZ (area indicated with box, casing included)	05700-002-79-50
1	1	Motor Only, 208-230V, 60 HZ Motor Only, 460V, 60 HZ	06105-002-79-61 06105-003-52-64
2	1	Shim Kit	05700-002-82-58
3	1	Case Capscrew	05305-002-81-88
4	2 2 2	Bolt, 3/8" Lock Washer, 3/8" Nut Hex, 3/8"	05311-276-03-00 05311-276-01-00 05310-276-01-00
5	1	Pump Casing S/S, 60 HZ	05700-002-85-00
6	1	Impeller Assebmlly, 60 HZ	05700-002-81-86
7	1	Mechanical Seal, 60 HZ	05330-002-34-22
8	1	Case O-Ring, 60 HZ Seal Plate, 60 HZ	05330-002-81-83 05700-002-81-87
		Drain Plug (not shown)	04730-002-81-89
9	1	Mounting Bracket	05700-003-31-58

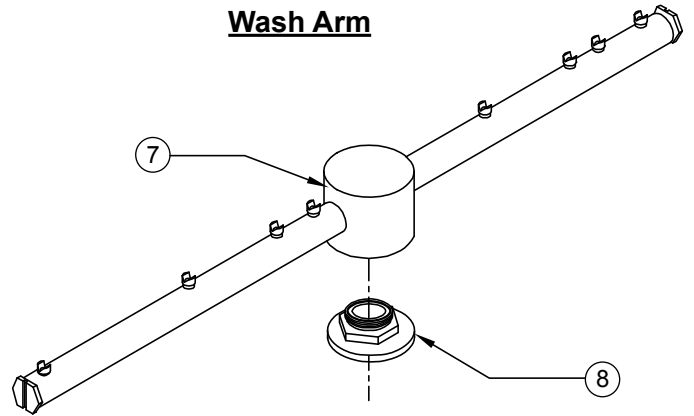
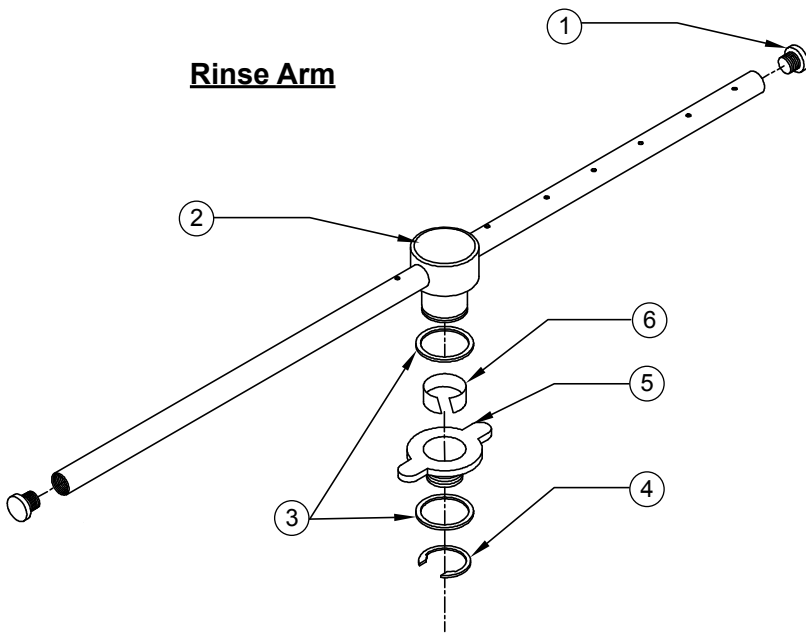

ITEM	QTY	DESCRIPTION	PART NUMBER
	2	Rinse Arm Assembly (Noble UH30 units ONLY)	05700-031-39-21
1	2	Plug, Rinse Arm	04730-609-04-00
2	1	Rinse Arm	05700-031-38-30
3	1	Washer, Rinse Arm	05330-011-42-10
	1	O-Ring (not shown)	05330-002-60-69
4	1	Ring, Retaining	05340-112-01-11
5	1	Bushing, Rinse Head	05700-021-33-84
6	1	Bearing	03120-002-72-24
	2 per LT 1 per HT	Wash Arm Assembly	05700-021-39-23
7	1	Wash Arm Weldment w/Plugs	05700-021-45-58
8	1	Bearing Assembly	05700-021-35-97
		O-Ring (not shown)	05330-002-60-69

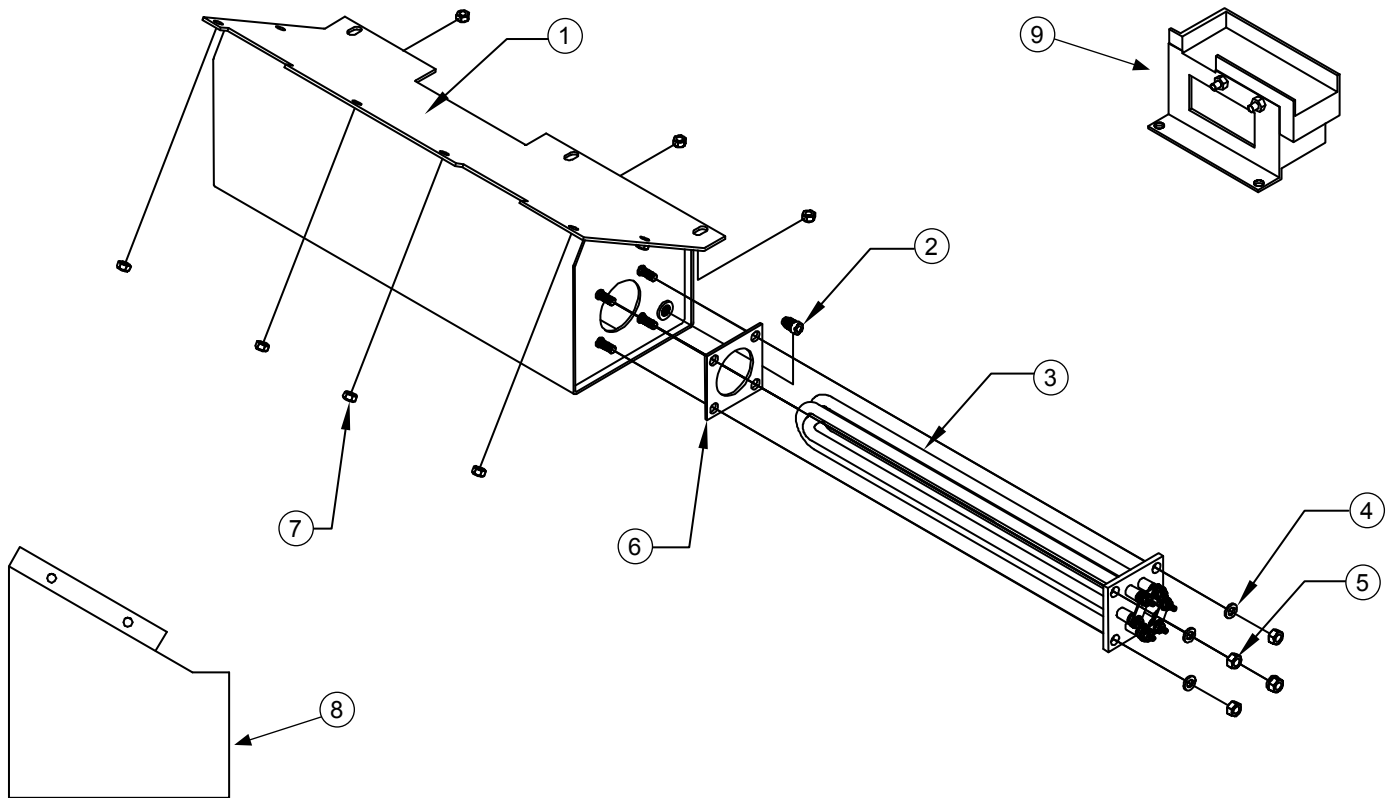

ITEM	QTY	DESCRIPTION	PART NUMBER
1	1	Rinse Tank Weldment	05700-003-31-95
2	1	Fittin, 1/4" Imperial Brass	05310-924-02-05
3	1	Heater: 208-230 Volt Heater: 480 Volt	04540-111-43-21 04540-002-29-82
4	4	Lock Washer, 5/16" Split	05311-275-01-00
5	4	Nut, Hex 5/16"- 18 S/S Hex	05310-275-01-00
6	1	Gasket, Heater	05330-011-47-79
7	9	Locknut, 1/4"-20 S/S Hex w/ Nylon Insert	05310-374-01-00
8	1	Dielectric Cover	05700-001-40-50
9	1	Thermostat	05930-003-06-48

*NOBLE UL30 OPTIONAL  
THERMOSTAT & HEATER COMPONENTS*

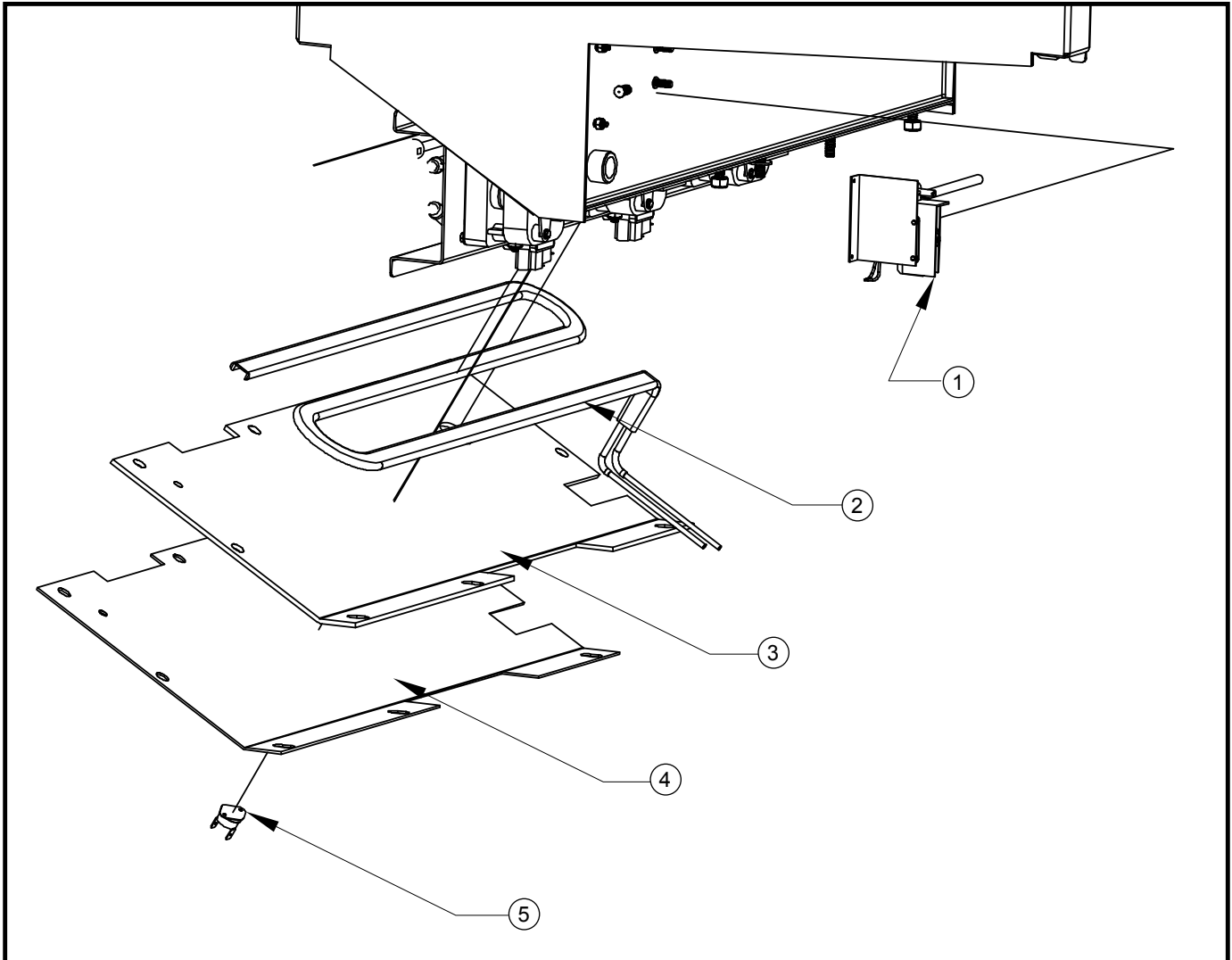

ITEM	QTY	DESCRIPTION	PART NUMBER
1	1	Wash Thermostat	05930-003-13-65
2	1	Heater, Fire Bar	04540-003-46-27
3	1	Insulation Paper 1/8"	04540-003-46-30
4	1	Heater Cover Plate	05700-003-46-37
5	1	High Limit Thermostat	06685-003-46-77

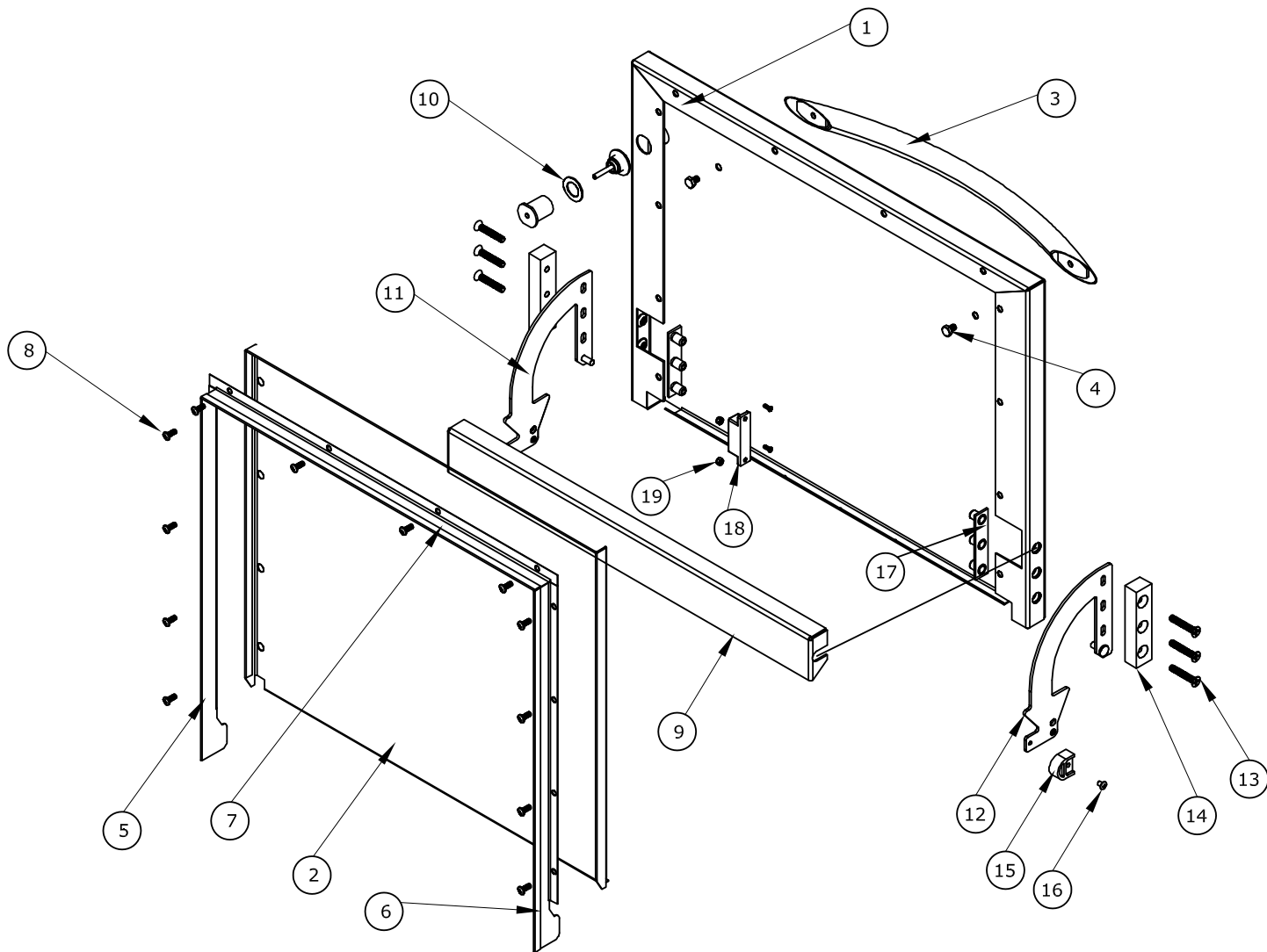

ITEM	QTY	DESCRIPTION	PART NUMBER
1	1	Outer Door Weldment	05700-003-33-37
2	1	Inner Door Weldment	05700-003-33-21
3	1	Door Handle	05700-003-26-62
4	2	Bolt, 1/4"-20 X 3/8" Long	05305-274-20-00
5	1	Channel, Right Seal	05700-003-33-19
6	1	Channel, Left Deal	05700-003-33-20
7	1	Channel, Top Seal	05700-003-33-22
8	12	Screw, 10-32 X 1/2" Pan Phillips Head	05305-011-44-52
9	1	Baffle, Door	05700-003-33-38
10	1	Start Switch Assembly	05700-003-34-80
11	1	Hinge, Right Weldment	05700-003-32-72
12	1	Hinge, Left Weldment	05700-003-32-71
13	6	Screw, 1/4"-20 X 1-1/2" Pan Phillips Head	05305-011-44-50
14	2	Hinge Spacer	05700-003-33-42
15	2	Stop, Door Hinge	05700-003-32-55
16	2	Screw, Number 10 Pan Head 18-8 S/S X 1/2"	05305-173-01-00
17	2	Retaining Plate Assembly	05700-011-44-37
18	1	Magnet, Reed Switch	05930-002-68-53
19	2	Lock Nut, 6-32 S/S Hex W/ Nylon Insert	05310-373-03-00



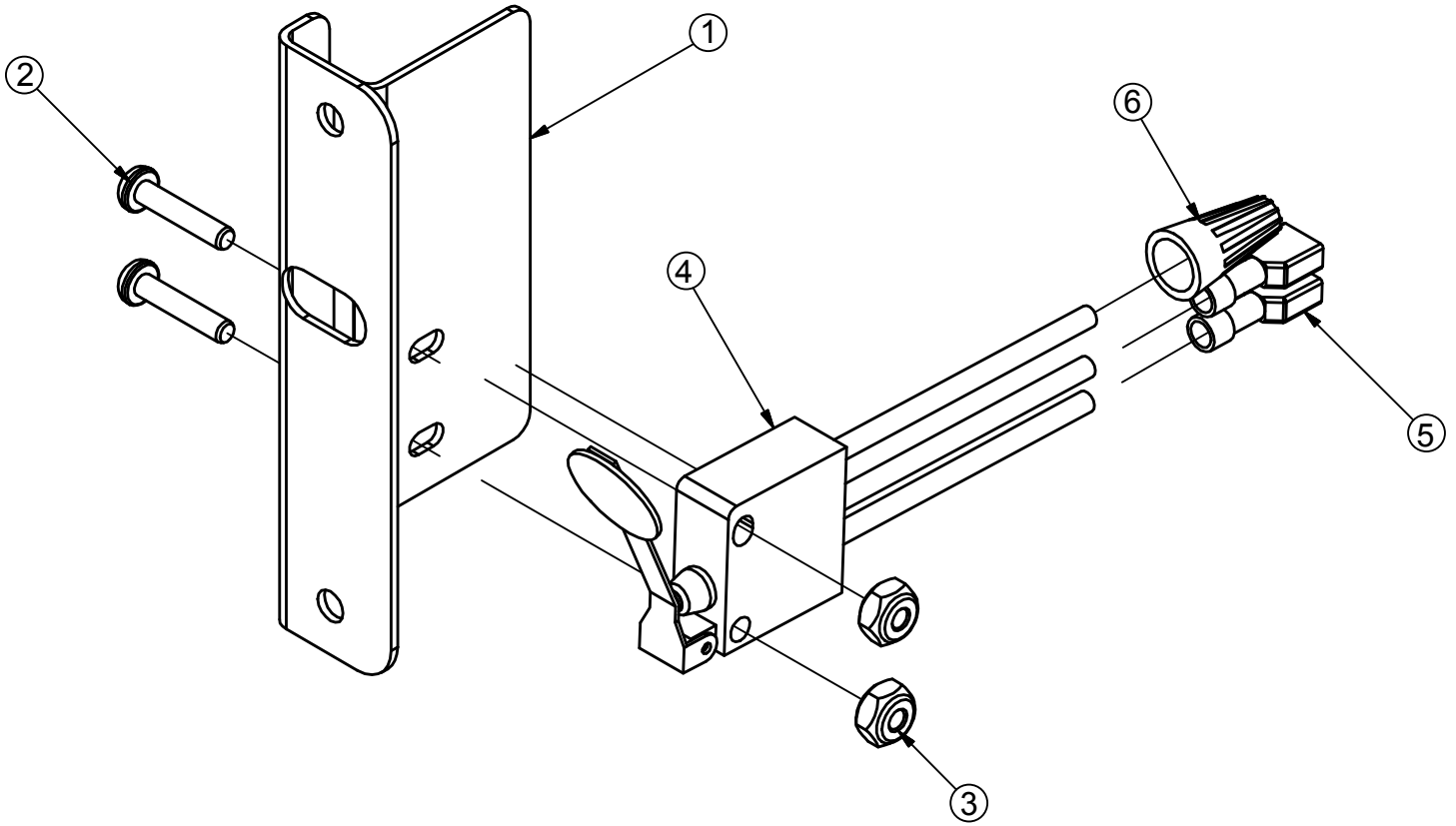

ITEM	QTY	DESCRIPTION	PART NUMBER
		Clyde Switch Arm Assembly	05700-003-52-14
1	1	F-Plate, Switch Cover RT	05700-003-52-10
2	1	Screw, 6-32 X 5/8"	05305-011-39-85
3	1	Lock Nut 6-32 Hex w/ Nylon Insert	05310-373-03-00
4	1	Cycle Switch Weldment	05700-003-36-81
5	2	Term, 190030013 .187 Pink Reel	05940-111-45-18
6	1	Wire Nut, Blue Metal 30-172 Ideal	05945-111-01-00

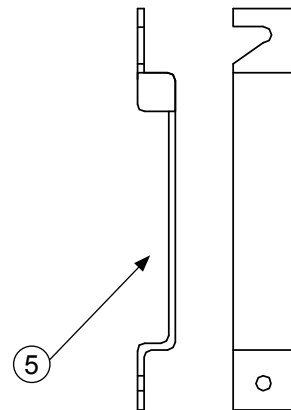
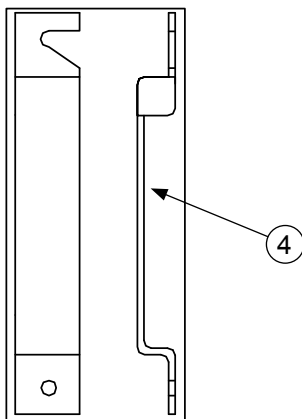
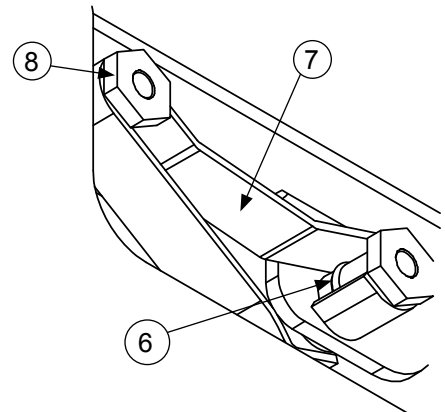
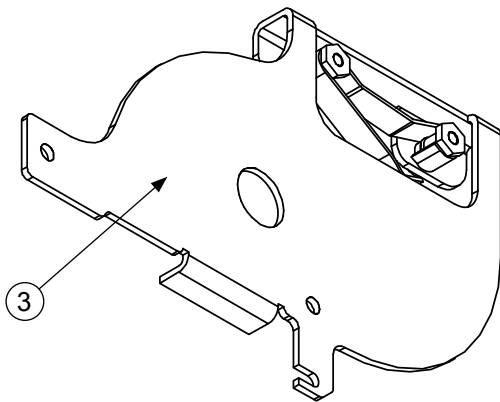
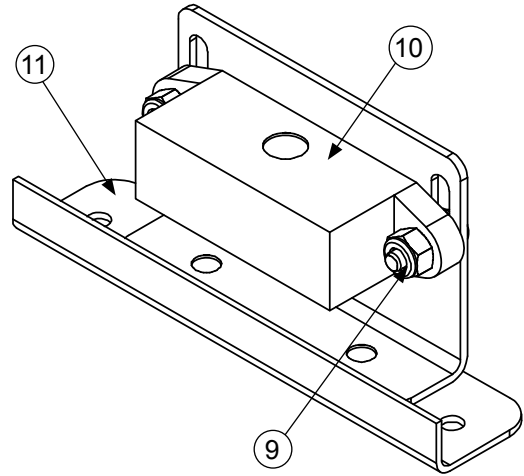
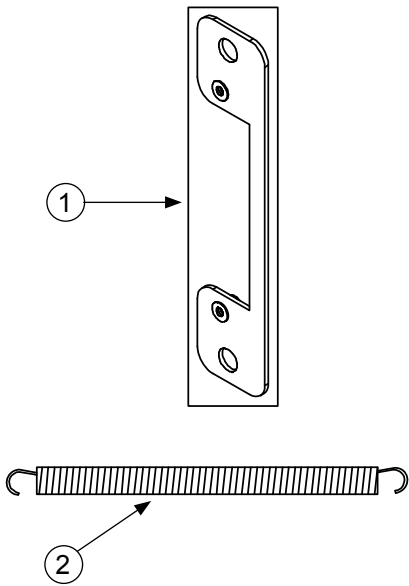

ITEM	QTY	DESCRIPTION	PART NUMBER
1	1	Switch Mounting Plate Assembly	05700-003-33-54
2	1	Door Spring	05700-003-32-85
3	1	Hinge Stop Assembly: Right	05700-003-32-61
	1	Hinge Stop Assembly: Left (not shown)	05700-003-32-60
	1	Hinge Stop Assembly: Right	05700-003-32-63
	1	Hinge Stop Assembly: Left (not shown)	05700-003-32-61
4	1	Cover, Left Hinge Weldment	05700-002-18-41
5	1	Cover, Right Hinge Weldment	05700-002-18-42
		Hinge Components secured with: Locknut, 1/4"-20 S/S Hex with Nylon Insert	05310-374-01-00
6	2	O-Ring	05330-003-32-34
7	1	Latch Spring	05700-003-32-32
8	2	Latch Nut	05700-003-32-33
9	2	Hardware: Locknut, 6-32 S/S Hex with Nylon Insert	05310-373-03-00
	2	Screw, 6-32 X 1/4" Flat Head	05305-171-01-00
10	1	Door Switch	05930-003-31-44
11	1	Door Switch Bracket	05700-003-31-43
		Door Switch & Bracket Assembly	05700-003-32-21

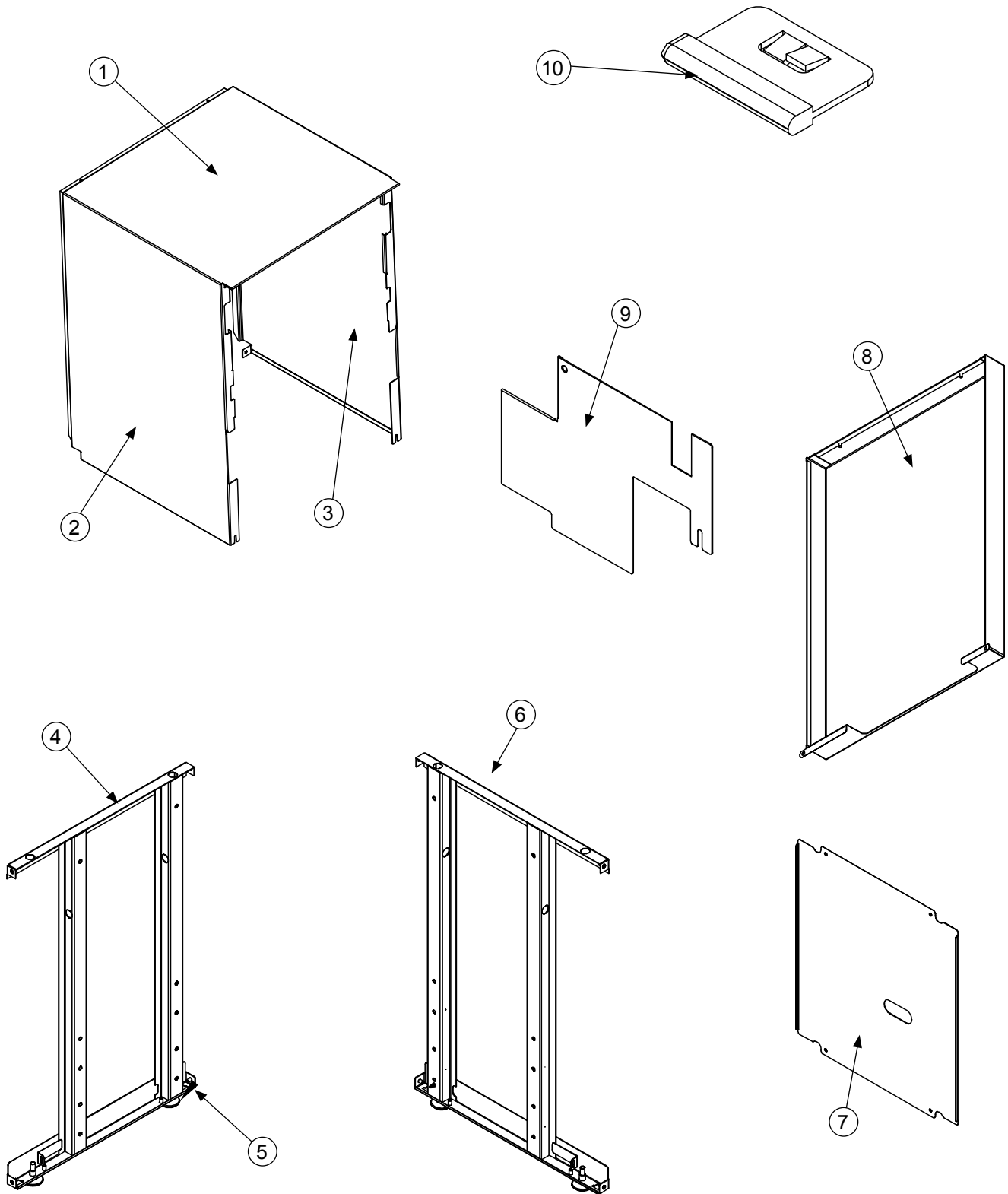

ITEM	QTY	DESCRIPTION	PART NUMBER
1	1	Top Shroud Weldment	05700-003-37-06
2	1	Left Shroud Weldment	05700-003-37-04
3	1	Right Shroud Weldment	05700-003-37-05
4	1	Left Frame Weldment	05700-003-31-91
5	1	Swivel Feet	05340-108-02-00
6	1	Right Frame Weldment	05700-003-31-90
	4	Hardware: Nut, 1/4"-20 Serrated Hex	05310-959-03-00
	4	Nut, 5/16"-18 Cad Spine	05310-959-03-00
7	1	Optional Bottom Panel	05700-003-32-92
8	1	Optional Back Panel	05700-003-33-55
9	1	Standard Back Panel	05700-003-36-35
10	2	Shroud Plug	05700-003-32-50

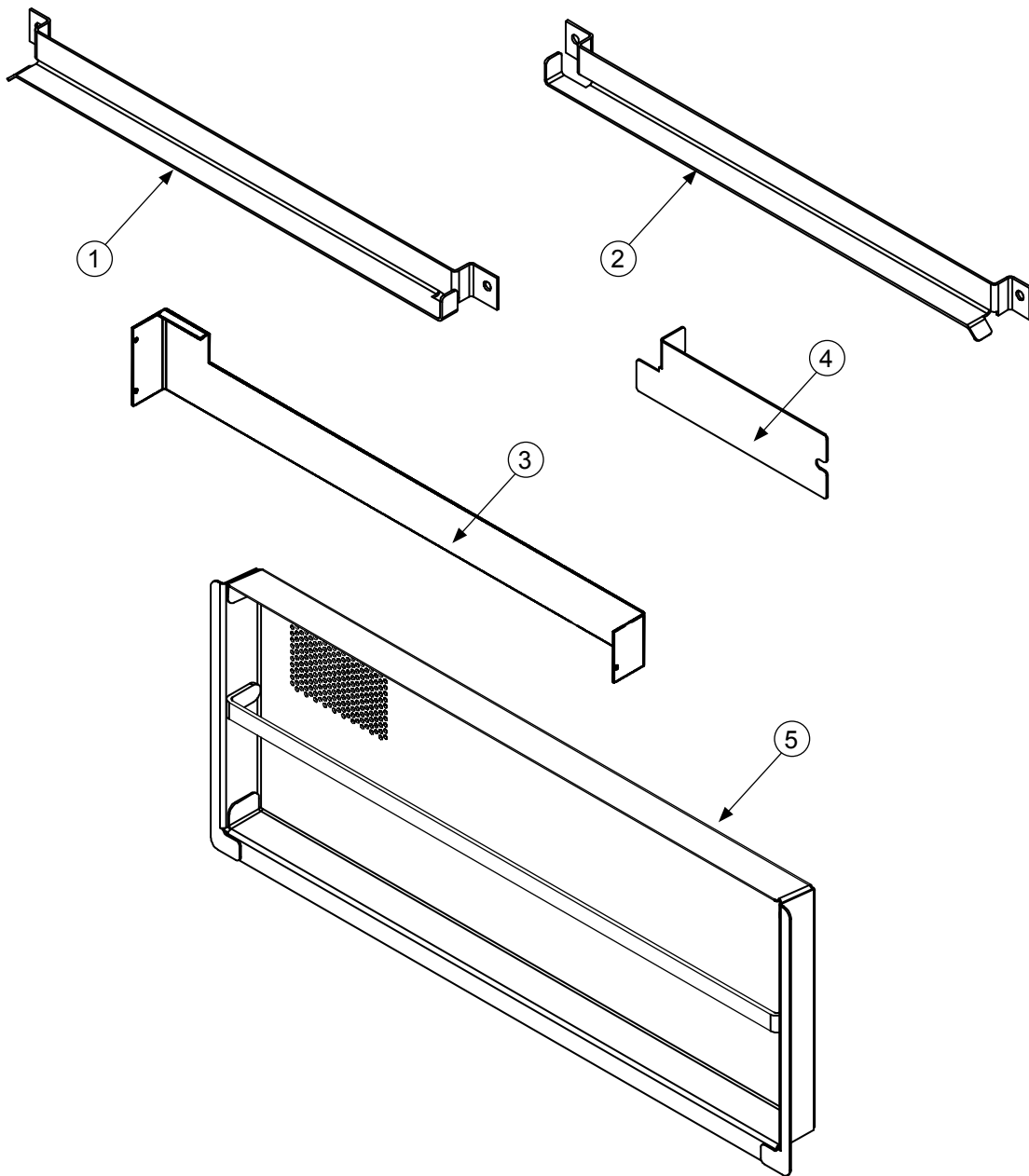

ITEM	QTY	DESCRIPTION	PART NUMBER
		Components secured with: Locknut, 1/4"-20 S/S Hex with Nylon Insert	05310-374-01-00
1	1	Rail, Left Rack	05700-031-37-88
2	1	Rail, Right Rack	05700-031-37-88
3	1	Splash Shield	05700-003-33-51
4	1	Strainer Spacer	05700-001-35-83
		Attaches with: Nut, Nylon Wing, 1/4"-20	05310-994-01-00
5	1	Strainer Weldment	05700-003-32-81

**INSTALLATION INSTRUCTIONS:** To install the stand, first remove the adjustable feet from the machine. Place machine on table and use the square mounting holes to line up the machine. Re-insert the adjustable feet through bottom of table top and tighten to lock machine to table.

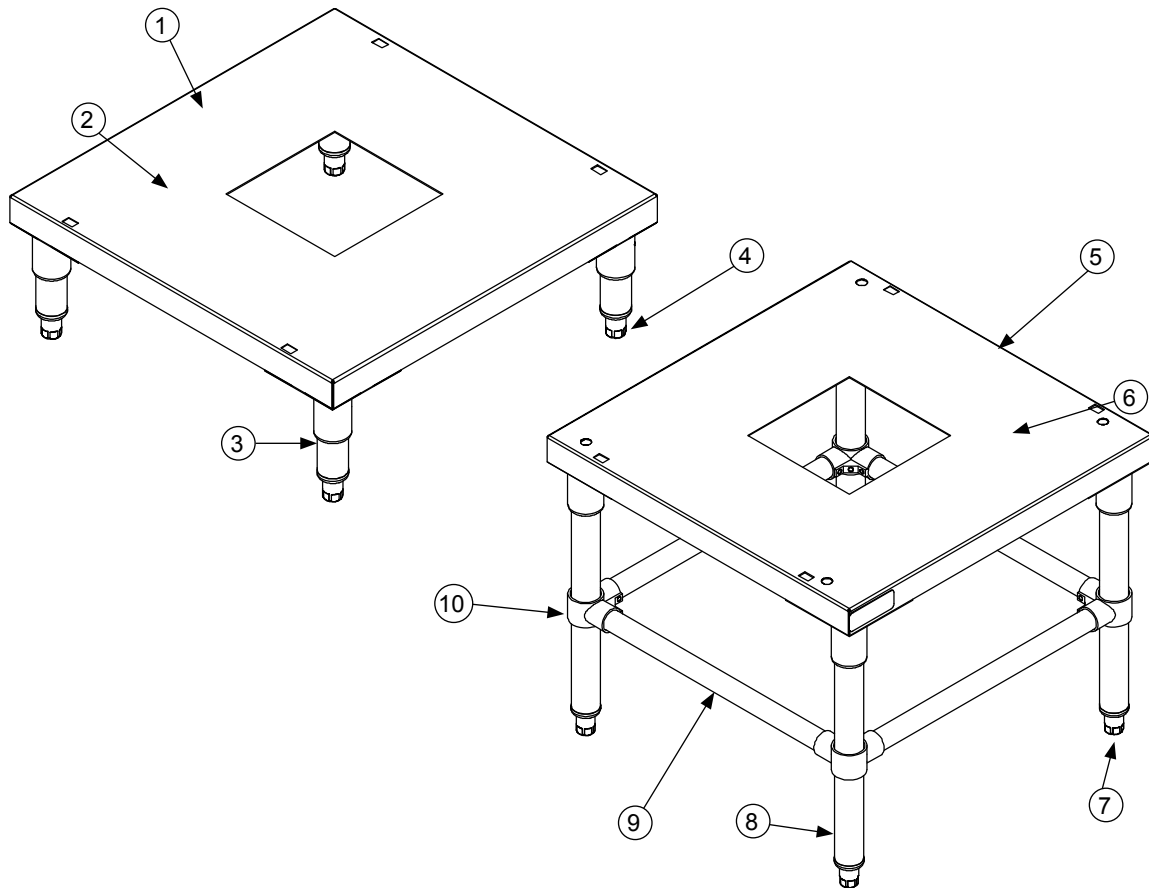

ITEM	QTY	DESCRIPTION	PART NUMBER
1	1	6" Stand Assembly	05700-003-34-24
2	1	Stand	05700-002-88-82
3	4	6" Leg	05700-021-61-10
4	4	Bullet Foot	05340-108-01-03
5	1	18" Stand Assembly	05700-003-34-25
6	1	Stand	05700-002-88-82
7	4	Bullet Foot	05340-108-01-03
8	4	18" Leg	05700-002-89-47
9	4	Cross Brace	05700-003-25-90
10	4	Cross Member Bracket	04730-003-25-89

# HTS-11 SCALE PREVENTION & CORROSION CONTROL DEVICE

**INSTALLATION INSTRUCTIONS:** Must be installed vertically. The provided bracket is to be secured to the wall. Observe proper inlet/outlet water directions. Flow directions are molded into the top of the head. Line pressure should be released prior to changing cartridges. De-liming of equipment prior to installation is recommended but no required.

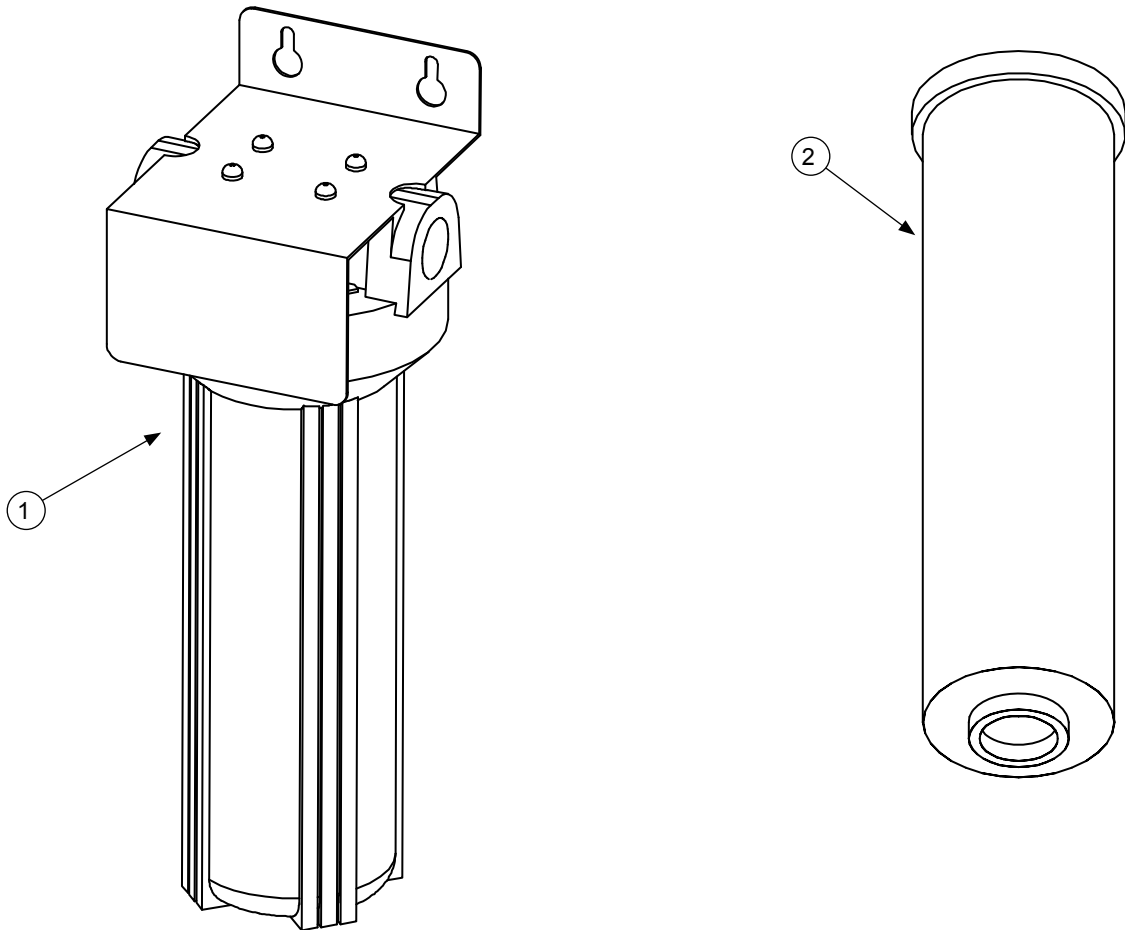

ITEM	QTY	DESCRIPTION	PART NUMBER
1	1	Kleeneware HTS-11 System	04730-003-28-03
2	1	Replacement Cartridge (Inspect at least every 6 months)	04730-003-28-04
		Replacement Test Strip (not shown)	06401-003-28-06



A GO Box is a kit of the most needed parts for a particular model or model family to successfully effect a repair in the first call 90% or more of the time.

ITEM	QTY	DESCRIPTION	PART NUMBER
1	1	Rinse Thermostat	05930-003-06-48
2	1	Contactator/Heater	05945-002-74-20
3	1	Pump Seat	05330-002-34-22
4	1	Pump Gasket O-Ring	05330-002-81-83
5	1	Door Switch (Reed)	05930-003-31-44
6	1	Relay, 220-240-Volt	05945-111-89-75
7	1	Relay, 115 Volt	05945-002-47-41
8	2	Switch, Det/Rinse Aid Prime	05930-011-49-54
9	2	Switch, On/Off	05930-301-49-00
10	2	Switch, Auto/Manual	05930-011-49-55
11	1	Fill Solenoid Valve 1/2"	004810-100-09-18
12	1	Vacuum Breaker	04820-003-06-13
13	1	Timer, Universal	05945-003-33-09
14	4	Washer Rinse Arm	05330-011-42-10
15	2	Ring, Retaining	05340-112-01-11
16	2	Bearing Assembly, Wash Arm	05700-021-35-97
17	2	Squeeze Tube, 3/16"	05700-111-35-29
18	2	Squeeze Tube	05700-011-76-41
19*	1	Pump & Motor Assembly	06105-002-72-75

\* Special pricing when purchased with a GO BOX. Call for details.

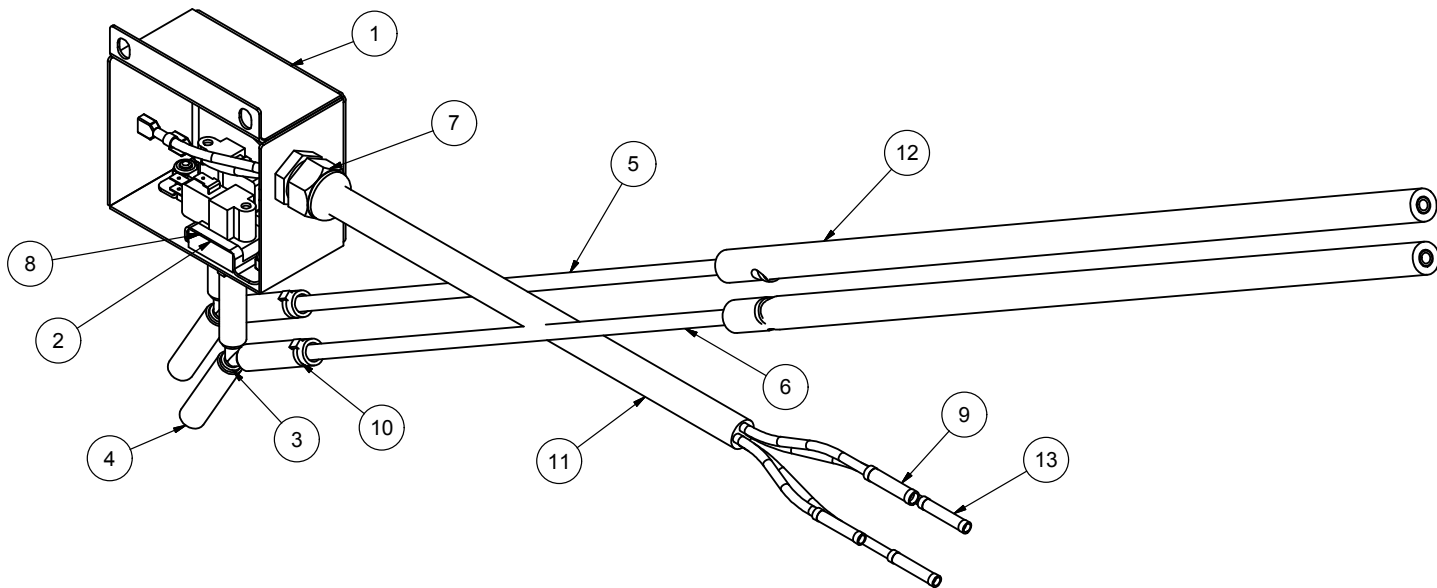

ITEM	QTY	DESCRIPTION	PART NUMBER
		Complete Assembly	05700-003-55-98
1	1	Box, Vacuum Switch	05700-003-55-96
2	2	Switch, Vacuum	05700-003-36-13
3	2	Wye, 1/4" Barbed PVDF	04730-003-36-14
4	6	Tubing, Clear 5/16 ID	04710-003-53-26
5	1	A-Tube, Red 1/4 OD X 100 Long	05700-003-03-45
6	1	A-Tube, White 1/4 OD X 100 Long	05700-003-03-45
7	1	Fitting, Liquidtite .231 X .394 Heyco	05700-003-20-67
8	2	F-Pressure Switch Bracket	05700-003-53-03
9	2	Splice, Blue Butt	5940-200-11-44
10	6	Locknut, 10-24 X 3/8 Phillips Truss	05945-602-01-16
11	14	A-Cable, 18 GA/5 Con 46"	35597
12	3	Tube Stiffener	05700-002-66-49
13	2	Splice, Red Butt	05940-200-26-00

Remove locknut on plumbing support brackets and mount switch box over existing stud. Re-install bracket and route red and white tubes behind blue hose as shown.

Route gray cable down back and under tub along inlet plumbing, remove wires from existing pressure switches and connect gray cable per note below.



Locknut

### Detergent switch (Red Tube)

1. Connect black wire from gray cable to black/yellow wire from switch.
2. Connect brown wire from gray cable to blue wire from switch.

### Sanitizer Switch (White Tube)

1. Connect white wire gray cable to white/yellow wire from switch.
2. Connect red wire from gray cable to blue from switch.

After Cutting existing red & white tube approximately 12" above the gray tube stiffener, insert the cut ends into the clear tubes as shown.

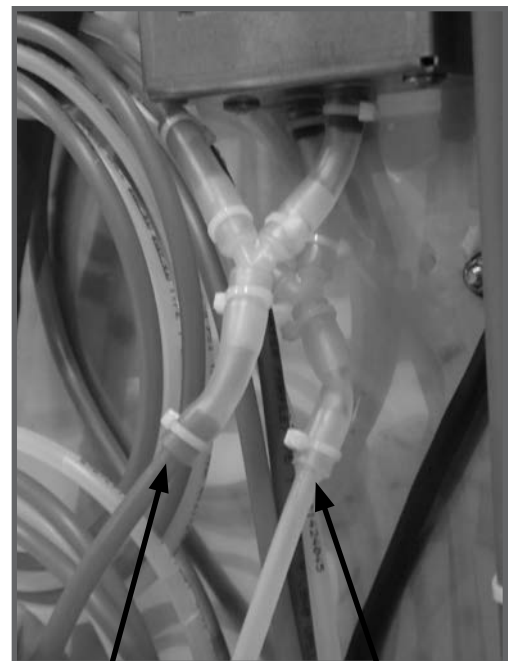

Red Tube

White Tube

# NOBLE UH30

## 208-230 VOLT, 60 HERTZ, SINGLE PHASE

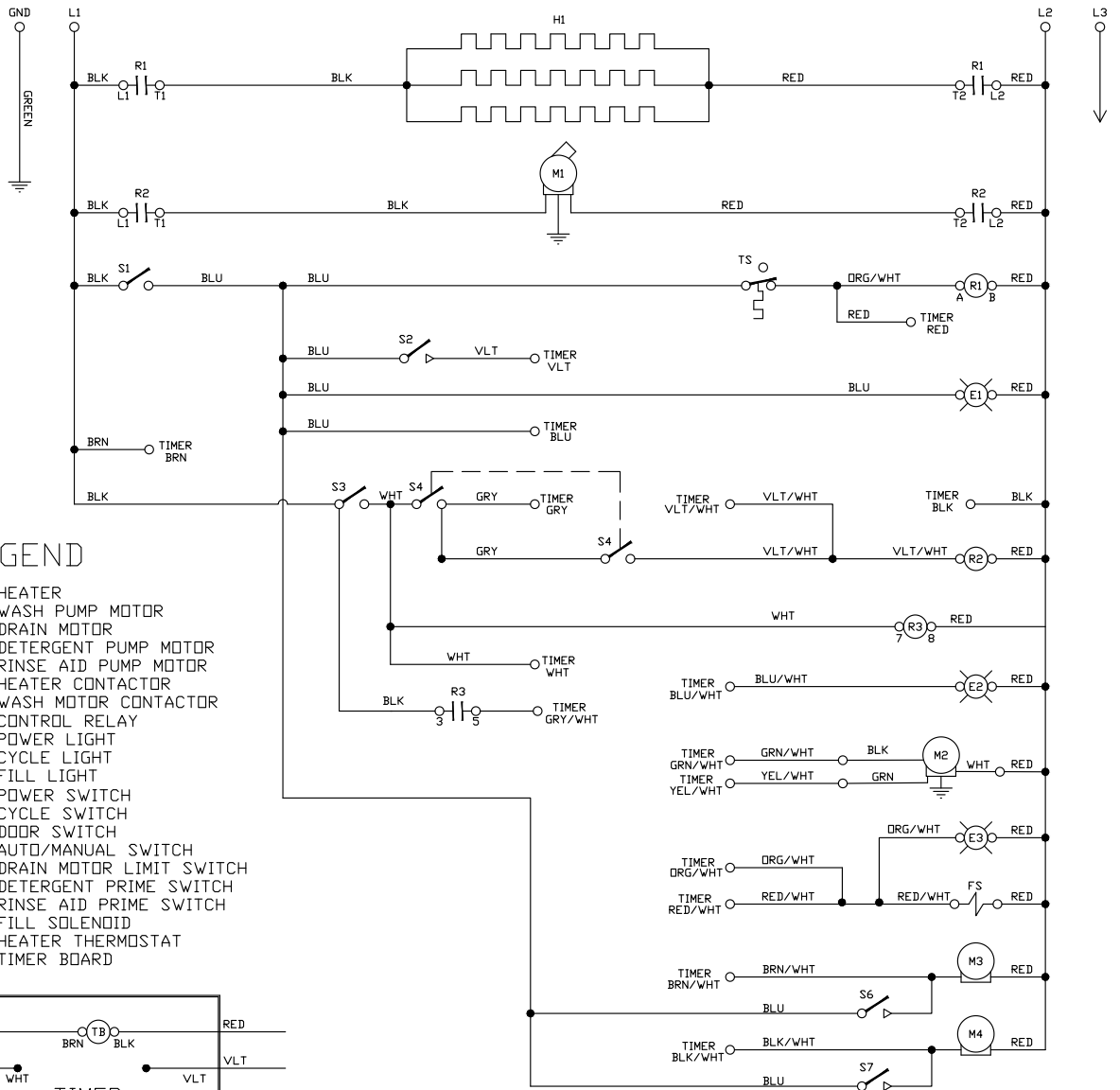

**LEGEND**

- H1 HEATER
- M1 WASH MOTOR
- M2 DRAIN MOTOR
- M3 DETERGENT PUMP MOTOR
- M4 RINSE AID PUMP MOTOR
- R1 HEATER CONTACTOR
- R2 WASH MOTOR CONTACTOR
- R3 CONTROL RELAY
- R3 POWER LIGHT
- E1 CYCLE LIGHT
- E2 FILL LIGHT
- E3 FILL LIGHT
- S1 POWER SWITCH
- S2 CYCLE SWITCH
- S3 DOOR SWITCH
- S4 AUTO/MANUAL SWITCH
- S5 DRAIN MOTOR LIMIT SWITCH
- S6 DETERGENT PRIME SWITCH
- S7 RINSE AID PRIME SWITCH
- FS FILL SOLENOID
- TS HEATER THERMOSTAT
- TB TIMER BOARD

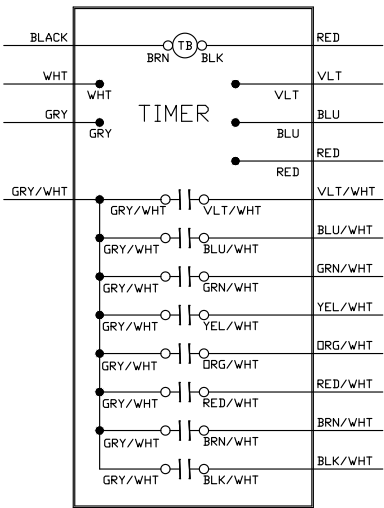

**TIMING CHART**

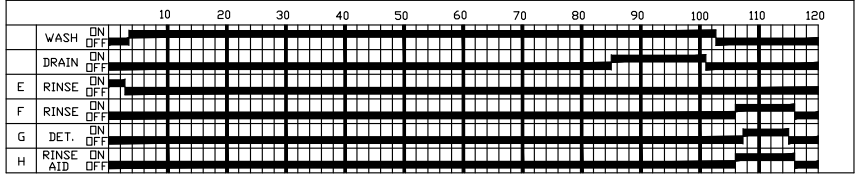

# NOBLE UH30

## 480 VOLT, 60 HERTZ, THREE PHASE

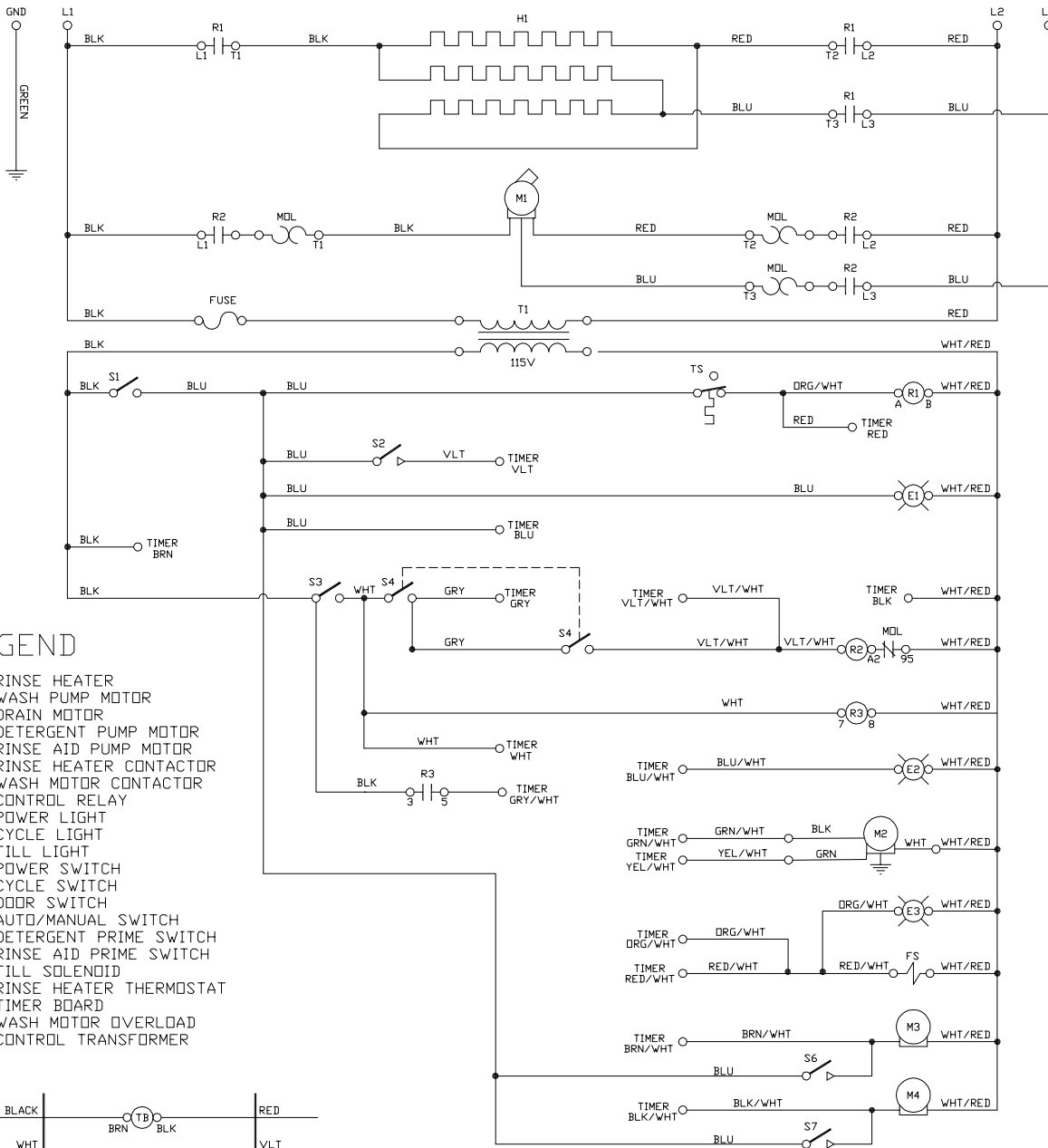

### LEGEND

- H1 RINSE HEATER
- M1 WASH PUMP MOTOR
- M2 DRAIN MOTOR
- M3 DETERGENT PUMP MOTOR
- M4 RINSE AID PUMP MOTOR
- R1 RINSE HEATER CONTACTOR
- R2 WASH MOTOR CONTACTOR
- R3 CONTROL RELAY
- E1 POWER LIGHT
- E2 CYCLE LIGHT
- E3 FILL LIGHT
- S1 POWER SWITCH
- S2 CYCLE SWITCH
- S3 DOOR SWITCH
- S4 AUTO/MANUAL SWITCH
- S6 DETERGENT PRIME SWITCH
- S7 RINSE AID PRIME SWITCH
- FS FILL SOLENOID
- TS RINSE HEATER THERMOSTAT
- TB TIMER BOARD
- MDL WASH MOTOR OVERLOAD
- T1 CONTROL TRANSFORMER

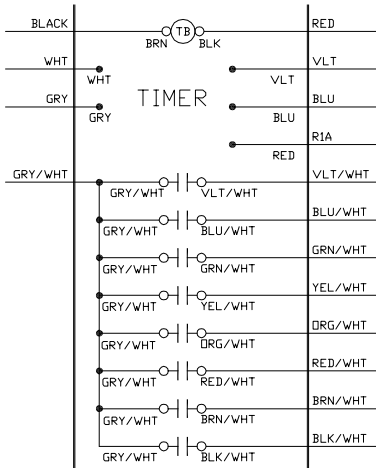

TIMING CHART

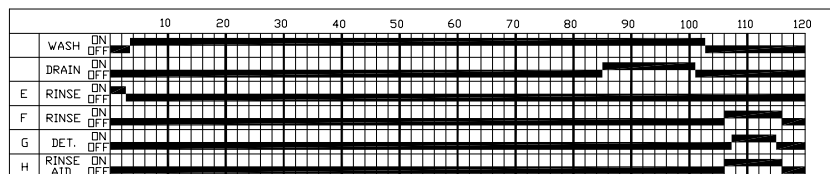

# NOBLE UL30

## 115 VOLT, 60 HERTZ, SINGLE PHASE

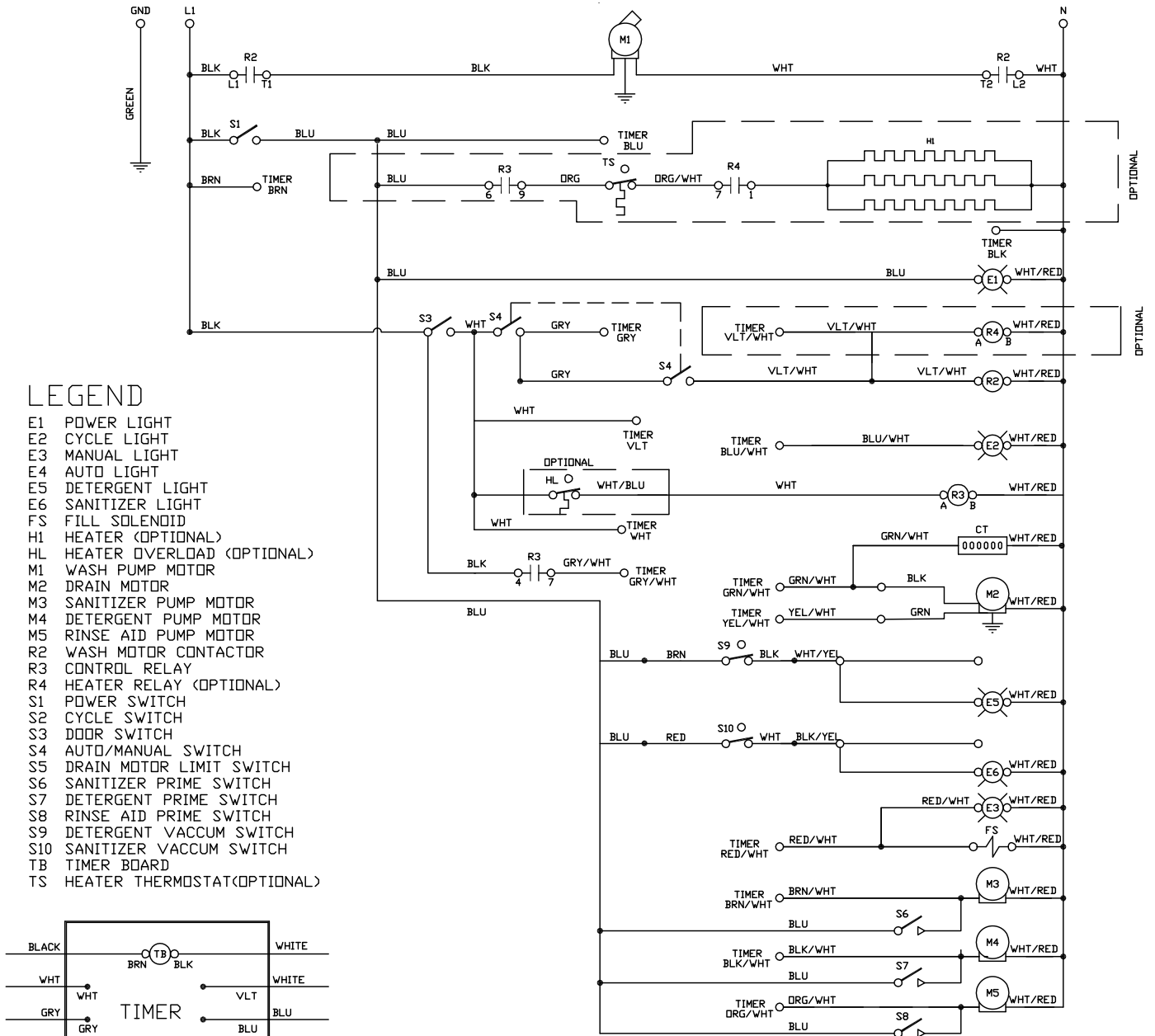

**LEGEND**

- E1 POWER LIGHT
- E2 CYCLE LIGHT
- E3 MANUAL LIGHT
- E4 AUTO LIGHT
- E5 DETERGENT LIGHT
- E6 SANITIZER LIGHT
- F5 FILL SOLENOID
- H1 HEATER (OPTIONAL)
- HL HEATER OVERLOAD (OPTIONAL)
- M1 WASH PUMP MOTOR
- M2 DRAIN MOTOR
- M3 SANITIZER PUMP MOTOR
- M4 DETERGENT PUMP MOTOR
- M5 RINSE AID PUMP MOTOR
- R2 WASH MOTOR CONTACTOR
- R3 CONTROL RELAY
- R4 HEATER RELAY (OPTIONAL)
- S1 POWER SWITCH
- S2 CYCLE SWITCH
- S3 DOOR SWITCH
- S4 AUTO/MANUAL SWITCH
- S5 DRAIN MOTOR LIMIT SWITCH
- S6 SANITIZER PRIME SWITCH
- S7 DETERGENT PRIME SWITCH
- S8 RINSE AID PRIME SWITCH
- S9 DETERGENT VACCUM SWITCH
- S10 SANITIZER VACCUM SWITCH
- TB TIMER BOARD
- TS HEATER THERMOSTAT(OPTIONAL)

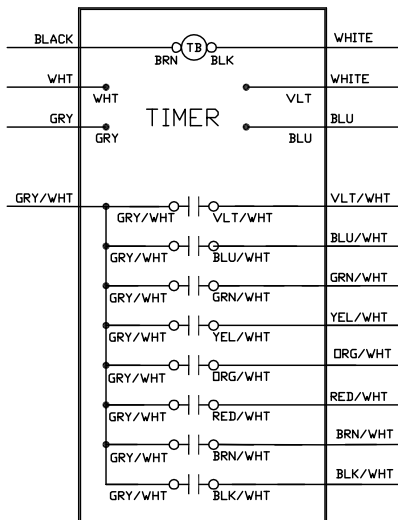

**TIMING CHART**

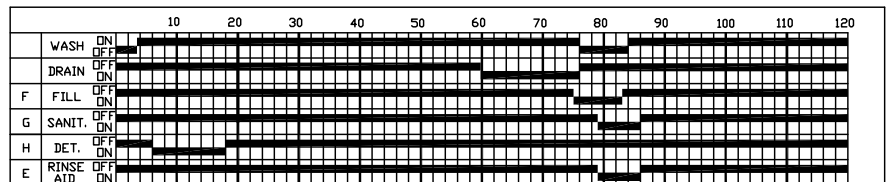





Noble Warewashing • Lancaster, Pennsylvania  
[www.nobleproducts.biz](http://www.nobleproducts.biz)