

Dear ANKOVO System Owner:

Thank you for purchasing the **ANKOVO** Blood Glucose Monitoring System. This manual provides important information to help you to use the system properly. Before using this product, please read the following contents thoroughly and carefully.

Regular monitoring of your blood glucose levels can help you and your doctor gain better control of your diabetes. Due to its compact size and easy operation, you can use the **ANKOVO** Blood Glucose Monitoring System to easily monitor your blood glucose levels by yourself anywhere, any time.

If you have other questions regarding this product, please contact the local customer service or place of purchase.

Intended Use

This system is intended for use outside the body (*in vitro* diagnostic use) by people with diabetes at home and by health care professionals in clinical settings as an aid to monitoring the effectiveness of diabetes control. It is intended to be used for the quantitative measurement of glucose (sugar) in fresh capillary whole blood samples from the finger, palm, forearm and upper arm.

It should not be used for the diagnosis or screening of diabetes.

Test Principle

Your system measures the amount of glucose in whole blood. The glucose testing is based on the measurement of electrical current generated by the reaction of glucose with the reagent of the strip. The meter measures the current, calculates the glucose level, and displays the result. The strength of the current produced by the reaction depends on the amount of glucose in the blood sample.

IMPORTANT SAFETY PRECAUTIONS

READ BEFORE USE

1. Use this device **ONLY** for the intended use described in this manual.
2. Do **NOT** use accessories which are not specified by the manufacturer.
3. Do **NOT** use the device if it is not working properly or if it is damaged.
4. Do **NOT** use the equipment in places where aerosol sprays are being used or where oxygen is being administered.
5. This device does **NOT** serve as a cure for any symptoms or diseases. The data measured is for reference only. Always consult your doctor to have the results interpreted.
6. Before using this device to test blood glucose, read all instructions thoroughly and practice the test. Carry out all the quality control checks as directed.
7. Keep the device and testing equipment away from young children. Small items such as the battery cover, batteries, test strips, lancets and vial caps are choking hazards.
8. Use of this instrument in a dry environment, especially if synthetic materials are present (synthetic clothing, carpets etc.) may cause damaging static discharges that may cause erroneous results.
9. Do **NOT** use this instrument in close proximity to sources of strong electromagnetic radiation, as these may interfere with the accurate operation.
10. Proper maintenance and periodically control solution test are essential to the longevity of your device. If you are concerned about your accuracy of measurement, please contact the local customer service or place of purchase for help.

KEEP THESE INSTRUCTIONS IN A SAFE PLACE

TABLE OF CONTENTS

BEFORE YOU BEGIN	1
Important Information.....	1
Meter Overview.....	2
Display Screen.....	3
Test Strip.....	4
SETTING THE METER	4
THE FOUR MEASURING MODES	6
QUALITY CONTROL TESTING	7
When Should the Control Solution Test be Performed?.....	7
Performing a Control Solution Test.....	7
TESTING WITH BLOOD SAMPLE	9
Preparing the Lancing Device for Blood Testing.....	9
Preparing the Puncture Site.....	9
Performing a Blood Glucose Test.....	10
Alternative Site Testing.....	12
METER MEMORY	13
Reviewing Test Results.....	13
Reviewing Blood Glucose Day Average Results.....	13
DOWNLOADING RESULTS ONTO A COMPUTER	14
MAINTENANCE	15
Battery.....	15
Replacing the Battery.....	15
Caring for Your Meter.....	16
Caring for Your Test Strips.....	16
Important Control Solution Information.....	17
MEASUREMENT RESULT READING	18
Result Readings.....	18
Reference Values.....	18
SYSTEM TROUBLESHOOTING	19
Error Messages.....	19
Troubleshooting.....	20
SYMBOL INFORMATION	21
SPECIFICATIONS	22

(a) (b) (c) (d) (e) (f)

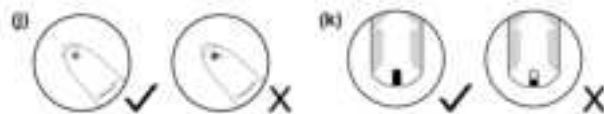

BEFORE YOU BEGIN

Important Information

- Severe dehydration and excessive water loss may cause readings which are lower than actual values. If you believe you are suffering from severe dehydration, consult a healthcare professional immediately.
- If your blood glucose results are lower or higher than usual, and you do not have any symptoms of illness, first repeat the test. If you have symptoms or continue to get results which are higher or lower than usual, follow the treatment advice of your healthcare professional.
- Use only fresh whole blood samples to test your blood glucose. Using other substances will lead to incorrect results.
- If you are experiencing symptoms that are inconsistent with your blood glucose test results and you have followed all the instructions given in this owner's manual, contact your healthcare professional
- We do not recommend using this product on severely hypotensive individuals or patients in shock. Please consult the healthcare professional before use.
- The measurement unit used for indicating the concentration of blood or plasma glucose can either have a weight dimension (mg/dL) or a molarity (mmol/L). The approximate calculation rule for conversion of mg/dL in mmol/L is:

mg/dL	Divided by 18	= mmol/L
mmol/L	Times 18	= mg/dL

For example:

1) $120 \text{ mg/dL} \div 18 = 6.6 \text{ mmol/L}$

2) $7.2 \text{ mmol/L} \times 18 = 129 \text{ mg/dL}$ approximately.

Meter Overview

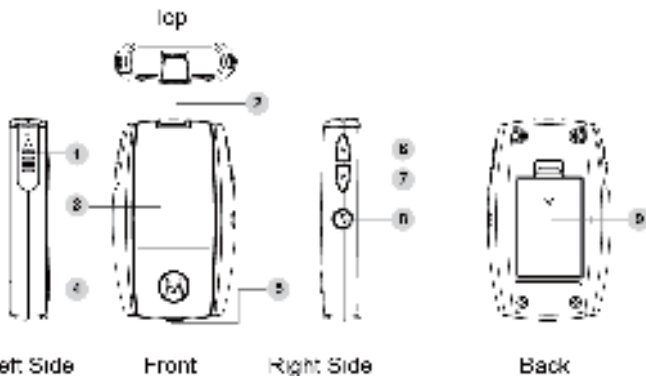

1 Test Strip Ejector

Eject the used strip by pushing up this button.

2 Test Strip Slot

Insert test strip here to turn the meter on for testing.

3 Display Screen

4 Main Button (M)

Enter the meter memory and silence a reminder alarm.

5 No

6 Up Button (UP)

7 Down Button (DOWN)

8 SET Button (S)

Enter and confirm the meter settings.

9 Battery Compartment

Display Screen

- 1 Test Result
- 2 Error Warning
- 3 Face/Low/High Symbol
- 4 Measuring Mode
AC – before meal
PC – after meal
Gen – any time of day
- 5 Alarm Symbol
- 6 Date
- 7 Time
- 8 Day Average
- 9 Memory Symbol
- 10 Control Solution Mode
QC – control solution test
- 11 Ketone Warning

- 12 Measurement Unit
- 13 Low Battery Symbol
- 14 Test Strip Symbol
- 15 Blood Drop Symbol

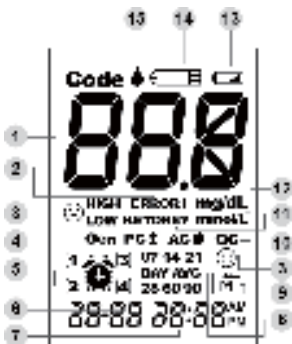

Test Strip

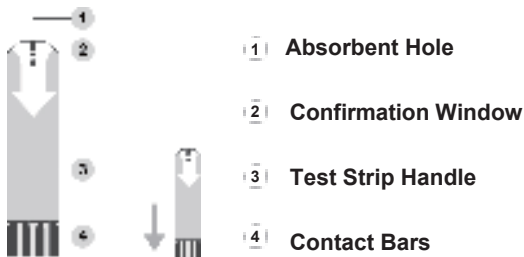

ATTENTION:

The front side of test strip should face up when inserting test strip.

Test results might be wrong if the contact bar is not fully inserted into the test slot.

NOTE:

The **ANKOVO TD-4267** monitor should only be used with **ANKOVO TD-4267** Test Strips. Using other test strips with this meter can produce inaccurate results.

SETTING THE METER

Before using your meter for the first time or if you change the meter battery, you should check and update these settings.

Entering the Setting Mode (a)

Start with the meter off (no test strip inserted). Press **S**.

1. Setting the date

The sequence of the date setting is: YEAR → MONTH → DAY. With the YEAR / MONTH / DAY flashing in sequence, press **UP** or **DOWN** until the correct year/month/day appears. Press **S**.

2. **Setting the time format**

Press **UP** or **DOWN** to select the desired time format (12h or 24h). Press **S**.

3. **Setting the time**

With the HOUR / MINUTE flashing in sequence, press **UP** or **DOWN** until the correct hour/minute appears. Press **S**.

4. **Setting the unit of measurement**

Press **UP** or **DOWN** to switch between mg/dL and mmol/L.
Press **S**.

5. **Setting the buzzer**

With the buzzer displays, press **UP** or **DOWN** to switch between “On” and “OFF”. Press **S**.

6. **Deleting the memory**

With “dEL” and “” on the display, press **UP** or **DOWN** and select “no” to keep the results in memory then press **S** to skip.
To delete all the results, press **UP** or **DOWN** and select “yes” to delete all the memory records.

7. **Setting the reminder alarm**

Your meter has four reminder alarms. The meter will display “OFF” and “”. If you don’t want to set an alarm, press **S** to skip this step. Or press **UP** or **DOWN** to select “On”, then press **S**.

With the hour/minute flashing in sequence, press **UP** or **DOWN** to select the correct hour/minute. Press **S** and go to the next alarm setting.

NOTICE:

When the alarm beeping: Press **M** to silence it or press and hold **M** to switch it off. Otherwise, it will beep for 2 minutes then switch off.



Congratulations! You have completed all settings!

NOTE:

- These parameters can **ONLY be changed** in the setting mode.
- If the meter is idle for 3 minutes during the setting mode, it will switch off automatically.

THE FOUR MEASURING MODES

The meter provides you with four modes for measuring, General, AC, PC and QC. You can switch between each mode by:

1. Start with the meter switched off. Insert a test strip to turn on the meter. The screen will display “”, a flashing “” and “Gen”.
2. Press **M** to switch between General, AC, PC and QC mode.

QUALITY CONTROL TESTING

When Should the Control Solution Test be Performed?



- if it is mandatory following the local regulations in your country,
- if you suspect the meter or test strips are not working properly,
- if your test results are not consistent with how you feel, or if you think the results are not accurate,
- to practice the testing process, or
- if you have dropped or think you may have damaged the meter.

Test strips **(c)**, control solutions **(d)**, lancing device **(e)** or sterile lancets **(f)** may not be included in the kit (please check the contents on your product box). They can be purchased separately. Please make sure you have those items needed for a blood glucose test beforehand.

Performing a Control Solution Test

To perform a control solution test, you will need: **(b)**, **(c)** and **(d)**.

1. Insert the test strip to turn on the meter

Insert the test strip into the meter. Wait for the meter to display the  and .

2. Press **M** to mark this test as a control solution test

With **“QC”** displayed, the meter will not store your test result in memory. If you press **M** again, the **“QC”** will disappear and this test is no longer a control solution test.

WARNING:

When doing the control solution test, you have to mark it so that the test result will **NOT** be stored in the memory. Failure to do so will mix up the blood glucose test results with the control solution test results in memory.

3. Apply control solution (g)

Shake the control solution vial thoroughly before use. Squeeze out the first drop and wipe it off, then squeeze out another drop and place it on the tip of the vial cap. Hold the meter to move the absorbent hole of the test strip to touch the drop. Once the confirmation window fills completely, the meter will begin counting down.

NOTE:

To avoid contaminating the control solution, do not directly apply control solution onto a strip.

4. Read and compare the result

After counting down to 0, the control solution test result will appear on the display. Compare this result with the range printed on the test strip vial and it should fall within this range. If not, please read the instructions again and repeat the control solution test.

**Control Solution Range(Normal)****129~175/7.2~9.7****NOTE:**

- The control solution range printed on the test strip vial is for control solution use only. It is not a recommended range for your blood glucose level.
- See the **MAINTENANCE** section for important information about your control solutions.

TESTING WITH BLOOD SAMPLE

Warning:

To reduce the chance of infection:

- Never share a lancet or the lancing device.
- Always use a new, sterile lancet. Lancets are for single use only.
- Avoid getting hand lotion, oils, dirt, or debris in or on the lancets and the lancing device.

Preparing the Lancing Device for Blood Testing

Please follow the instructions in the lancing device insert for collecting a blood sample.

Preparing the Puncture Site

Stimulating blood perfusion by rubbing the puncture site before blood extraction has a significant influence on the glucose value obtained. Blood from a site that has not been rubbed exhibits a measurably different glucose concentration than blood from the finger. When the puncture site was rubbed prior to blood extraction, the difference was significantly reduced.

Please follow the suggestions below before obtaining a drop of blood:

- **Wash and dry your hands before starting.**
- Select the puncture site either at fingertips or another body parts (please see section “Alternative Site Testing” (AST) on how to select the appropriate sites).
- Rub the puncture site for about 20 seconds before penetration.
- Clean the puncture site using cotton moistened with 70% alcohol and **let it air dry.**
- Use a clear cap (optional) while setting up the lancing device.

● **Fingertip testing (h)**

Press the lancing device's tip firmly against the lower side of your fingertip. Press the release button to prick your finger, then a click indicates that the puncture is complete.

● **Blood from sites other than the fingertip (i)**

Replace the lancing device cap with the clear cap for AST. Pull the cocking control back until it clicks. When lancing the forearm, upper arm, or hand, avoid lancing the areas with obvious veins because of excessive bleeding.

NOTE:

- Choose a different spot each time you test. Repeated punctures at the same spot may cause soreness and calluses.
- Please consult your health care professional before you begin AST.
- It is recommended that you discard the first drop of blood as it might contain tissue fluid, which may affect the test result.

Performing a Blood Glucose Test

To perform a blood glucose test, you will need: **(b)**, **(c)**, **(e)** and **(f)**.

1. Insert the test strip to turn on the meter

Wait for the meter to display the “” and “”.

2. Select the appropriate measuring mode by pressing M.

3. Obtaining a blood sample (j)

Use the pre-set lancing device to puncture the desired site. The size of the drop should be at least as big as  (actual size), which is 0.5 microliter (μL) of volume. Gently squeeze the punctured area to obtain another drop of blood. Be careful **NOT** to smear the blood sample.

● Apply the sample (k)

Gently apply the drop of blood to the absorbent hole of the test strip at a tilted angle. Confirmation window should be completely filled if enough blood sample has been applied. Do **NOT** remove your finger until you hear a beep sound.



NOTE:

- Do not press the punctured site against the test strip or try to smear the blood.
- If you do not apply a blood sample to the test strip within 3 minutes, the meter will automatically turn off. You must remove and reinsert the test strip to start a new test.
- The confirmation window should be filled with blood before the meter begins to count down. **NEVER** try to add more blood to the test strip after the drop of blood has moved away. **Discard the used test strip and retest with a new one.**
- If you have trouble filling the confirmation window, please contact your health care professional or the local customer service for assistance.

4. Read Your Result

The result of your blood glucose test will appear after the meter counts down to 0. The blood glucose result will be stored in the memory automatically.

5. Eject the used test strip (l)

Eject the test strip by pushing the eject button on the side. Use a sharp bin to dispose of used test strips. The meter will switch itself off automatically.

Always follow the instructions in the lancing device insert when removing the lancet.

WARNING:

The used lancet and test strip may be biohazardous. Please discard them carefully according to your local regulations.

Alternative Site Testing

You can test on a variety of locations on your body.

Important:

**There are limitations with AST
(Alternative Site Testing).**

**Please consult your health care
professional before you perform AST.**



When to use AST?

Food, medication, illness, stress and exercise can affect blood glucose levels. Capillary blood at the fingertip reflects these changes faster than capillary blood at other sites. Thus, when testing blood glucose during or immediately after a meal, physical exercise, or any other event, **take a blood sample from your finger only.**

We strongly recommend that you perform AST **ONLY** at the following times:

- In a pre-meal or fasting state (more than 2 hours since the last meal).
- Two hours or more after taking insulin.
- Two hours or more after exercise.

Do NOT use AST if:

- You think your blood glucose is low.
- You are unaware of hypoglycemia
- You are testing for hyperglycemia
- Your AST results do not match the way you feel.
- Your routine glucose results often fluctuate.

METER MEMORY

The meter stores the 450 most recent blood glucose test results along with respective dates and times in its memory. To enter the meter memory, **start with the meter switched off.**

Reviewing Test Results

1. **Press and release M.**

“” will appear on the display. Press **M** again, and the first reading you see is the last blood glucose result along with date, time and the measuring mode.

2. **Press M** to recall the test results stored in the meter each time you press. **After the last test result, press M again and the meter will be off.**

Reviewing Blood Glucose Day Average Results

1. **Press and release M.** When “” appears on the display, keep pressing **M** for 3 seconds until the flashing “**DAY AVG**” appears. Release **M** and then your 7-day average result measured in general mode will appear on the display.
2. **Press M to review** 14-, 21-, 28-, 60- and 90- day average results stored in each measuring mode in the order of Gen, AC, then PC.
3. **Exit the meter memory.**

Keep pressing the **M** and the meter will turn off after displaying the last test result.

NOTE:

- Any time you wish to exit the memory, keep pressing **M** for 5 seconds or leave it without any action for 3 minutes. The meter will switch off automatically.
- Control solution results are **NOT** included in the day average.



MAINTENANCE

Battery

Your meter comes with one 3V CR2032 lithium battery.

Low Battery Signal

The meter will display one of the messages below to alert you when the meter power is getting low.

1. **The “” symbol appears** along with display messages: The meter is functional and the result remains accurate, but it is time to change the battery.
2. **The “” symbol appears with E-b, Error and low:**
3. **The power is not enough to do a test. Please change the battery immediately.**

Replacing the Battery

To replace the battery (m), make sure the meter is turned off.

1. Press the edge of the battery cover and lift it up to remove.
2. Remove the old battery and replace with one 3V CR2032 lithium battery.
3. Close the battery cover. If the battery is inserted correctly, you will hear a “beep” afterwards.

NOTE:

- Replacing the battery does not affect the test results stored in the memory.
- As with all small batteries, these batteries should be kept away from children. If swallowed, promptly seek medical assistance.
- Battery might leak chemicals if unused for a long time. Remove the battery if you are not going to use the device for an extended period (i.e., 3 months or more).
- Properly dispose of the battery according to your local environmental regulations.

Caring for Your Meter

Cleaning

1. To clean the meter exterior, wipe it with a cloth moistened with tap water or a mild cleaning agent, then dry the device with a soft dry cloth. Do **NOT** rinse with water.
2. Do **NOT** use organic solvents to clean the meter.

Meter Storage

- Storage conditions: -20°C to 60°C (-4°F to 140°F), between 10% and 93% relative humidity (non-condensing).
- Always store or transport the meter in its original storage case.
- Avoid dropping and heavy impact.
- Avoid direct sunlight and high humidity.

Meter Disposal

The used meter should be treated as contaminated that may carry a risk of infection during measurement. The batteries in this used meter should be removed and the meter should be disposed in accordance with local regulations.

The meter falls outside the scope of the European Directive 2002/96/EC-Directive on waste electrical and electronic equipment (WEEE).

Caring for Your Test Strips

- Storage conditions: 4°C to 40°C (39.2°F to 104°F), between 10% and 85% relative humidity (non-condensing). Do **NOT** freeze.
- Store your test strips in their original vial only. Do not transfer to another container.
- Store test strip packages in a cool dry place. Keep away from direct sunlight and heat.

- After removing a test strip from the vial, immediately close the vial cap tightly.
- Touch the test strip with clean and dry hands. Use each test strip immediately after removing it from the vial.
- Write the opening date on the vial label when you first opened it. Discard remaining test strips after 6 months.
- Do not use test strips beyond the expiry date. This may cause inaccurate results.
- Do not bend, cut, or alter a test strip in any way.
- Keep the strip vial away from children since the cap and the test strip may be a choking hazard. If swallowed, promptly see a doctor for help.



For further information, please refer to the test strip package insert.

Important Control Solution Information

- Use only our control solutions with your meter.
- Do not use the control solution beyond the expiry date or 3 months after first opening. Write the opening date on the control solution vial and discard the remaining solution after 3 months.
- It is recommended that the control solution test be done at room temperature 20°C to 25°C (68°F to 77°F). Make sure your control solution, meter, and test strips are at this specified temperature range before testing.
- Shake the vial before use, discard the first drop of control solution, and wipe off the dispenser tip to ensure a pure sample and an accurate result.
- Store the control solution tightly closed at temperatures between 2°C to 30°C (35.6°F to 86°F). Do **NOT** freeze.

MEASUREMENT RESULT READING

Result Readings

MESSAGE	WHAT IT MEANS		
Lo	< 20 mg/dL (1.1 mmol/L)		
 LOW	20 to 69 mg/dL(1.1 and 3.8 mmol/L)		
	AC	PC	Gen
	70 to 129 mg/dL (3.8 to 7.1 mmol/L)	70 to 179 mg/dL (3.8 to 9.9 mmol/L)	70 to 119 mg/dL (3.8 to 6.6 mmol/L)
 HIGH	AC	PC	Gen
	130 to 239 mg/dL (7.2 to 13.2 mmol/L)	180 to 239 mg/dL (10 to 13.2 mmol/L)	120 to 239 mg/dL (6.6 to 13.2 mmol/L)
KETONE?	≥ 240 mg/dL (13.3 mmol/L)		
Hi	> 600 mg/dL (33.3 mmol/L)		

Reference Values

The meter provides you with plasma equivalent results.

Time of day	Normal plasma glucose range for people without diabetes (mg/dL)
Fasting and before meal	< 100 mg/dL (5.6 mmol/L)
2 hours after meals	< 140 mg/dL (7.8 mmol/L)

Source: American Diabetes Association. Standards of Medical Care in Diabetes- 2018 Jan; 41(Supplement 1): S1-S2.

Please consult your doctor to determine a target range that works best for you.

SYSTEM TROUBLESHOOTING

If you follow the recommended action but the problem persists, please call your local customer service.

Error Messages

MESSAGE	WHAT IT MEANS	WHAT TO DO
E-b	Appears when the battery is too low.	Replace the battery immediately.
E-U	Appears when a used test strip is inserted.	Repeat with a new test strip.
E-t	Appears when ambient temperature is above or below system operation range.	System operation range is 10°C to 40°C (50°F to 104°F). Repeat the test after the meter and test strip are in the above temperature range.
E-0 E-A E-E E-C	Problem with the meter.	Repeat the test with a new test strip. If the meter still does not work, please contact the customer service for assistance.
E-F	Appears when test strip is removed while counting down, or insufficient blood volume.	Review the instructions and repeat test with a new strip. If the problem persists, please contact the local customer service for help.

Troubleshooting

1. If the meter does not display a message after inserting a test strip:

POSSIBLE CAUSE	WHAT TO DO
Batteries exhausted.	Replace the batteries.
Test strip inserted upside down or incompletely.	Insert the test strip with contact bars end first and facing up.
Defective meter or test strips.	Please contact customer services.













2. If the test does not start after applying the sample:

POSSIBLE CAUSE	WHAT TO DO
Insufficient blood sample.	Repeat the test using a new test strip with larger volume of blood sample.
Defective test strip.	Repeat the test with a new test strip.
Sample applied after automatic switch-off (3 minutes after last user action).	Repeat the test with a new test strip. Apply sample only when flashing "👉" appears on the display.
Defective meter.	Please contact customer services.

3. If the control solution testing result is out of range:

POSSIBLE CAUSE	WHAT TO DO
Error in performing the test.	Read instructions thoroughly and repeat the test again.
Control solution vial was poorly shaken.	Shake the control solution vigorously and repeat the test again.
Expired or contaminated control solution.	Check the expiry date of the control solution.
Control solution that is too warm or too cold.	Control solution, meter, and test strips should be at room temperature 20°C to 25°C (68°F to 77°F) before testing.
Defective test strip.	Repeat the test with a new test strip.
Meter malfunction.	Please contact customer services.
Improper working of meter and test strip.	Please contact customer services.

SYMBOL INFORMATION

SYMBOL	REFERENT	SYMBOL	REFERENT
	<i>In vitro</i> diagnostic medical device		Manufacturer
	Consult instructions for use		Authorized representative in the European Community
	Temperature limit		Caution
	Use-by date		Humidity limitation
	Batch code		CE mark
	Serial number		RoHS compliance
	This device does not belong to household waste and must be returned to a collection point for recycling electric and electronic devices according to local laws. If it contains batteries, the batteries should be removed and disposed in accordance with locations for separate collection of spent batteries.		

www.ankovo.com

@Copyright and Distributed by Metene Limited
20947 Currier Road Suite O, Walnut, CA, 91789

All Rights Reserved

Email:cs@ankovo.com



TaiDoc Technology Corporation

B1-7F, No.127, Wugong 2nd Rd.,

Wugu Dist., 24888 New Taipei City, Taiwan



MedNet GmbH

Borkstraße 10, 48163 Münster, Germany



For self-testing

