



# ***MULTI V***<sup>TM</sup> **WATER** **IV**

## **INSTALLATION MANUAL**

Variable Refrigerant Flow  
Water Source Units  
6.0 to 48.0 Tons



# PROPRIETARY DATA NOTICE

This document, as well as all reports, illustrations, data, information, and other materials herein are the property of LG Electronics U.S.A., Inc., and are disclosed by LG Electronics U.S.A., Inc., only in confidence.  
This document is for design purposes only.

**Do not throw away, destroy, or lose this manual.**

**Please read carefully and store in a safe place for future reference.  
Content familiarity required for proper installation and safety of personnel and property.**

Follow the instructions in this manual to prevent product malfunction, property damage, injury, or death to users or other people. Incorrect operation due to ignoring any instructions can cause harm to personnel, or damage to property or equipment.

A summary of safety precautions begins on page 4.

IM\_MultiV\_WaterIV\_9\_18

For more technical materials such as submittals, engineering databooks, and catalogs, visit [www.lghvac.com](http://www.lghvac.com).

Freight Damage and Unit Replacements..... Your LG Manufacturer Representative  
Missing Parts..... Your LG Manufacturer Representative  
Received Wrong Water Source Unit Model ..... Your LG Manufacturer Representative  
Installation, Startup, and Commissioning Technical Assistance ..... 1-888-865-3026

For continual product development, LG Electronics U.S.A., Inc., reserves the right to change specifications without notice.

©LG Electronics U.S.A., Inc.

*This document, as well as all reports, illustrations, data, information, and other materials are the property of LG Electronics U.S.A., Inc.*

<b>Safety Precautions</b> .....	<b>4</b>	<b>Water Circuit Installation</b> .....	<b>75</b>
<b>Unit Nomenclature</b> .....	<b>8</b>	<i>Water Circuit Design</i> .....	75
<b>General Data</b> .....	<b>9</b>	<i>Field-Supplied Components for WSU Installation</i> .....	77
<i>ARWN Series Heat Pump Water Source Unit Specifications</i> .....	9	<i>Piping System Specifications</i> .....	78
<i>ARWB Series Heat Recovery Water Source Unit Specifications</i> .....	15	<b>ELECTRICAL System Installation</b> .....	<b>85</b>
<i>Heat Recovery Unit Specifications and Electrical Data</i> .....	21	<i>General Information</i> .....	85
<b>Electrical Data</b> .....	<b>22</b>	<i>Power Wiring</i> .....	86
<i>ARWN Series Heat Pump Water Source Units</i> .....	22	<i>Communication Cable</i> .....	87
<i>ARWB Series Heat Recovery Water Source Units</i> .....	23	<i>ARWN Series Heat Pump Systems (208-230V and 460V)</i> .....	88
<b>Water Source Unit Dimensions</b> .....	<b>24</b>	<i>ARWB Series Heat Recovery Systems (208-230V and 460V)</i> .....	89
<i>Single Frame Heat Pump and Heat Recovery</i> .....	24	<i>IDU Communication Cable</i> .....	90
<i>Dual Frame Heat Pump and Heat Recovery</i> .....	25	<i>Zone Control of Indoor Units</i> .....	91
<i>Triple Frame Heat Pump and Heat Recovery</i> .....	26	<i>Communication Cable</i> .....	92
<i>Heat Recovery Units</i> .....	27	<i>Option Settings for All Water Source Units</i> .....	93
<b>Refrigerant Flow Diagrams</b> .....	<b>30</b>	<b>Pre-commissioning</b> .....	<b>95</b>
<i>ARWN Heat Pump Systems</i> .....	30;	<i>Preparing the Electrical System / Indoor Unit Auto Addressing</i> .....	95
<i>Cooling Operation</i> .....	30	<i>Group Control / Central Control</i> .....	99
<i>Heating Operation</i> .....	31	<i>Indoor Unit Temperature Sensing Strategy/Air Balance</i> .....	102
<i>ARWB Heat Recovery Systems</i> .....	32	<i>Prepare the Refrigerant Piping System</i> .....	108
<i>Cooling Operation</i> .....	32	<i>Prepare Pre-comm Documents / Initiate a Request</i> .....	111
<i>Heating Operation</i> .....	33	<b>Maintenance</b> .....	<b>112</b>
<i>Simultaneous Operation Mode 1 (Cooling Based Operation)</i> .....	34	<i>Maintaining the Heat Exchanger</i> .....	112
<i>Simultaneous Operation Mode 2 (Heating Based Operation)</i> .....	35	<i>General Maintenance Schedule</i> .....	113
<i>PRHR022A, PRHR032A, PRHR042A Heat Recovery Units</i> .....	36	<b>LG Monitoring View (LGMV) Diagnostic Software</b> .....	<b>115</b>
<b>Cut Sheets</b> .....	<b>37</b>	<b>Error Code Tables</b> .....	<b>117</b>
<i>Water Source Unit Y-branch Kits for Heat Pump Systems</i> .....	37	<b>Installation Checklist</b> .....	<b>125</b>
<i>Indoor Unit Y-branch Kits for Heat Pump Systems</i> .....	38	<b>Pre-commissioning Checklist</b> .....	<b>127</b>
<i>Water Source Unit Y-branch Kits for Heat Recovery Systems</i> .....	39	<b>Refrigerant Charge Worksheet</b> .....	<b>131</b>
<i>Indoor Unit Y-branch Kits for Heat Recovery Systems</i> .....	40	<b>WSU Factory Refrigerant Charge</b> .....	<b>132</b>
<i>Header Kits</i> .....	41		
<b>Installation</b> .....	<b>43</b>		
<i>Placement Considerations</i> .....	43		
<i>Transporting/Lifting the Water Source Unit</i> .....	44		
<i>Water Source Unit Minimum Space Requirements</i> .....	45		
<i>General Mounting / Anchoring the Water Source Unit</i> .....	47		
<i>Heat Recovery Box Minimum Space Requirements</i> .....	48		
<b>Refrigerant piping Installation</b> .....	<b>49</b>		
<i>Computer-assisted Refrigerant Pipe Design</i> .....	49		
<i>Pipe Sizing for ARWN Series Heat Pump Systems</i> .....	59		
<i>Pipe Sizing for ARWB Series Heat Recovery Systems</i> .....	62		
<i>Pipe Layout</i> .....	65		
<i>Refrigerant Pipe Connections</i> .....	68		
<i>Insulating the Refrigerant Piping</i> .....	70		
<i>Pressure (Leak) Testing</i> .....	73		

The instructions below must be followed to prevent product malfunction, property damage, injury or death to the user or other people. Incorrect operation due to ignoring any instructions will cause harm or damage. The level of seriousness is classified by the symbols below.

## TABLE OF SYMBOLS

<b>DANGER</b>	<i>This symbol indicates an imminently hazardous situation which, if not avoided, will result in death or serious injury.</i>
<b>WARNING</b>	<i>This symbol indicates a potentially hazardous situation which, if not avoided, could result in death or serious injury.</i>
<b>CAUTION</b>	<i>This symbol indicates a potentially hazardous situation which, if not avoided, may result in minor or moderate injury.</i>
<b>Note:</b>	<i>This symbol Indicates situations that may result in equipment or property damage accidents only.</i>
	<i>This symbol indicates an action that should not be performed.</i>

## INSTALLATION

### **DANGER**

**Don't use or store flammable gas or combustibles near the unit.**

*There is risk of fire, explosion, and physical injury or death.*

### **WARNING**

The information in this manual is intended for use by trained, experienced, heating, ventilation, and air conditioning (HVAC) technicians who are familiar with variable refrigerant flow (VRF) HVAC systems and are equipped with the proper tools and test equipment. Have an emergency plan. Know how to obtain emergency medical and firefighting assistance.

*Failure to carefully read and follow all instructions in this manual can result in equipment malfunction, property damage, personal injury or death.*

**If any system components containing refrigerant are installed in a small space, take measures to prevent the refrigerant concentration from exceeding safety limits in the event of a refrigerant leak.**

*Consult the latest edition of the American Society of Heating, Refrigerating, and Air Conditioning Engineers (ASHRAE) Standard 15. If the refrigerant leaks and safety limits are exceeded, it could result in personal injuries or death from oxygen depletion.*

**Install the unit in a safe location. Avoid areas where it can be stepped on or fallen into.**

*There is risk of unit damage, physical injury or death.*

**Do not install, remove, or re-install the unit by yourself (end-user). Ask the dealer or a trained technician to install the unit.**

*Improper installation by the user may result in water leakage, fire, explosion, electric shock, physical injury or death.*

**For replacement of an installed unit, always contact an authorized LG service provider.**

*There is risk of fire, electric shock, explosion, and physical injury or death.*

**Do not install the water source units outside.**

*There is risk of fire, electric shock, explosion, and physical injury or death.*

**Water source units are shipped with refrigerant and the service valves closed. Do not open service valves on the unit until all non-condensibles have been removed from the piping system and authorization has been obtained from the commissioning agent.**

*There is a risk of physical injury or death.*

**Do not run the compressor with the service valves closed.**

*There is risk of explosion, physical injury, or death.*

**Periodically check that the water source unit is not damaged.**

*There is risk of explosion, physical injury, or death.*

**Replace all control box and panel covers.**

*If cover panels are not installed securely, dust, water and animals may enter the unit, causing fire, electric shock, and physical injury or death.*

**Always check for system refrigerant leaks after the unit has been installed or serviced.**

*Exposure to high concentration levels of refrigerant gas may lead to illness or death.*

**Do not install the unit using defective attaching, or mounting hardware. Do not install the unit on a defective stand.**

*There is risk of physical injury or death.*

**Wear protective gloves when handling equipment.**

*Sharp edges may cause personal injury.*

## INSTALLATION, CONTINUED

### **⚠ WARNING**

#### **Dispose the packing materials safely.**

- Packing materials, such as nails and other metal or wooden parts may cause puncture wounds or other injuries.
- Tear apart and throw away plastic packaging bags so that children may not play with them and risk suffocation and death.

#### **Do not install the unit in any location exposed to open flame or extreme heat. Do not touch the unit with wet hands.**

*There is risk of fire, electric shock, explosion, and physical injury or death.*

#### **Install the unit considering the potential for earthquakes.**

*Improper installation may cause the unit to fall, resulting in physical injury or death.*

#### **Do not change the settings of the protection devices.**

*If the pressure switch, thermal switch, or other protection device is shorted and forced to operate improperly, or parts other than those specified by LG are used, there is risk of fire, electric shock, explosion, and physical injury or death.*

#### **If the air conditioner is installed in a small space, take measures to prevent the refrigerant concentration from exceeding safety limits in the event of a refrigerant leak.**

*Consult the latest edition of ASHRAE (American Society of Heating, Refrigerating, and Air Conditioning Engineers) Standard 15. If the refrigerant leaks and safety limits are exceeded, it could result in personal injuries or death from oxygen depletion*

### **⚠ CAUTION**

#### **Be very careful when transporting the product.**

- Do not attempt to carry the product without assistance.
- Some products use polypropylene bands for packaging. Do not use polypropylene bands to lift the unit.

- Suspend the unit from the base at specified positions.

- Support the unit at a minimum of four points to avoid slippage from rigging apparatus.

- Failure to follow these Cautions can result in minor or moderate physical injury.

### **Note:**

LG Electronics U.S.A., Inc., is not responsible for any piping calculations, refrigerant leaks, degradation of performance, or any other potential problems or damages as a result of interconnecting piping, their joint connections, isolation valves, introduced debris inside the piping system, or other problems caused by the interconnecting piping system.

#### **Properly insulate all cold surfaces to prevent "sweating."**

*Cold surfaces such as uninsulated pipes can generate condensate that may drip and cause a slippery floor condition and/or water damage to walls.*

#### **When installing the unit in a hospital, mechanical room, or similar electromagnetic field (EMF) sensitive environment, provide sufficient protection against electrical noise.**

*Inverter equipment, power generators, high-frequency medical equipment, or radio communication equipment may cause the air conditioner to operate improperly. The unit may also affect such equipment by creating electrical noise that disturbs medical treatment or image broadcasting.*

#### **Do not use the product for special purposes such as preserving foods, works of art, wine coolers, or other precision air conditioning applications. This equipment is designed to provide comfort cooling and heating.**

*There is risk of property damage.*

#### **Do not make refrigerant substitutions. Use R410A only.**

*If a different refrigerant is used, or air mixes with original refrigerant, the unit will malfunction and be damaged.*

#### **When connecting refrigerant pipe, allow for pipe expansion.**

*Improper piping may cause refrigerant leaks and system malfunction.*

#### **Periodically check that the water source unit is not damaged.**

*There is a risk of equipment damage.*

**Take appropriate actions at the end of HVAC equipment life to recover, recycle, reclaim or destroy R410A refrigerant according to applicable U.S. Environmental Protection Agency (EPA) rules.**

**Install the water source unit in a safe location where no one can step on or fall onto it. Do not install the unit with defective attaching or mounting hardware.**

*There is risk of unit and property damage.*

**Install the drain hose to ensure adequate drainage.**

*There is a risk of water leakage and property damage.*

**Don't store or use flammable gas combustibles near the unit.**

*There is risk of product failure.*

**Always check for system refrigerant leaks after the unit has been installed or serviced.**

*Low refrigerant levels may cause product failure*

**The unit is shipped with refrigerant and the service valves closed. Do not open service valves on the unit until all non-condensibles have been removed from the piping system and authorization to do so has been obtained from the commissioning agent.**

*There is a risk of refrigerant contamination, refrigerant loss and equipment damage.*

**When installing the water source unit in a low-lying area, or a location that is not level, use a raised concrete pad or concrete blocks to provide a solid, level foundation.**

*A solid, level foundation may prevent water damage and reduce abnormal vibration.*

**Do not install the unit in a noise sensitive area.**

## WIRING

### ⚠ WARNING

The information in this manual is intended for use by an industry-qualified, experienced, certified electrician who is familiar with the U.S. National Electric Code (NEC) and is equipped with the proper tools and test instruments.

*Failure to carefully read and follow all instructions in this manual can result in equipment malfunction, property damage, personal injury or death.*

**All electric work must be performed by a licensed electrician and conform to local building codes or, in the absence of local codes, with the National Electrical Code, and the instructions given in this manual. If there is a conflict between the instructions in this manual and any local or national codes, follow the requirements of the local or national codes.**

*If the power source capacity is inadequate or the electric work is not performed properly, it may result in fire, electric shock, physical injury or death.*

**High voltage electricity is required to operate this system. Adhere to the NEC code and these instructions when wiring.**

*Improper connections and inadequate grounding can cause accidental injury or death.*

**Always ground the unit following local, state, and NEC codes.**

*There is risk of fire, electric shock, and physical injury or death.*

**Properly size all circuit breakers or fuses.**

*There is risk of fire, electric shock, explosion, physical injury or death.*

**Refer to local, state, and federal codes, and use power wires of sufficient current capacity and rating.**

*Wires that are too small may generate heat and cause a fire.*

**Secure all field wiring connections with appropriate wire strain relief.**

*Improperly securing wires will create undue stress on equipment power lugs. Inadequate connections may generate heat, cause a fire and physical injury or death.*

**Properly tighten all power lugs.**

*Loose wiring may cause a fire by overheating at connection points, resulting in equipment or property damage, physical injury, or death.*

**Do not change the settings of the protection devices.**

*If the pressure switch, thermal switch, or other protection devices are bypassed or forced to work improperly, or parts other than those specified by LG are used, there is risk of fire, electric shock, explosion, and physical injury or death.*

**Turn the power off at the nearest disconnect before servicing the equipment.**

*Electrical shock can cause physical injury or death.*

**Do not supply power to the unit until all installation and precommissioning tasks are complete and the LG authorized commissioning agent indicates it is safe to do so.**

## OPERATION

### ⚠ WARNING

**Do not allow water, dirt, or animals to enter the unit.**

*There is risk of unit failure, fire, electric shock, physical injury or death.*

**Do not provide power to or operate the unit if it is flooded or submerged.**

*There is risk of fire, electric shock, physical injury or death.*

**Use a dedicated power disconnect switch for this product.**

*There is risk of fire, electric shock, physical injury or death.*

**Do not operate the power disconnect switch with wet hands.**

*There is risk of fire, electric shock, physical injury or death.*

**Periodically verify the equipment mounts have not deteriorated.**

*If the base collapses, the unit could fall and cause property damage, product failure, physical injury or death.*

**Do not touch the refrigerant piping during or after operation.**

*It can cause burns or frostbite.*

**Do not operate the unit with the panel(s) or protective cover(s) removed; keep fingers and clothing away from moving parts.**

*The rotating, hot, cold, and high-voltage parts of the unit can cause physical injury or death.*

**If refrigerant gas leaks out, ventilate the area before operating the unit.**

*Leaking gas may cause fire, electric shock, explosion, physical injury or death if the water source unit is mounted in an enclosed, low-lying, or poorly ventilated area and the system develops a refrigerant leak.*

**To avoid physical injury, use caution when cleaning or servicing the air conditioner.**

**Water source units are shipped with a factory refrigerant charge and service valves closed. Do not open service valves on water source units until all non-condensable foreign substances are removed from the piping system and authorization to open valves is obtained from the LG-authorized commissioning agent. Do not run compressors with the service valves closed.**

*There is a risk of equipment damage, refrigerant contamination, refrigerant loss, physical injury or death.*

**Do not use this equipment in mission critical or special-purpose applications such as preserving foods, works of art, wine coolers or refrigeration. The equipment is designed to provide comfort cooling and heating only.**

*Oil, steam, sulfuric smoke, etc., can significantly reduce the performance of the unit, or damage its parts.*

**Do not turn off the main power switch after operation has been stopped.**

*Wait at least five (5) minutes before turning off the main power switch, otherwise it may result in product malfunction.*

**Provide power to the compressor crankcase heaters at least six (6) hours before operation begins.**

*Starting operation with a cold compressor sump(s) may result in severe bearing damage to the compressor(s). Keep the power switch on during the operational season.*

**Clean up the site after servicing is finished, and check that no metal scraps, screws, or bits of wiring have been left inside or surrounding the unit.**

### Note

#### Generation 4 Equipment

*The latest versions of LG's indoor units and water source units are designated Generation 4 (Gen 4). For Gen 4 units to operate with Gen 4 features, the air conditioning system must meet the following requirements:*

- All indoor units, heat recovery units, and water source units must be Gen 4.
- All water source units must have Gen 4 software installed.
- Water source units DIP switch 3 must be set to ON (factory default setting is OFF).
- All controllers must support Gen 4 features.

# UNIT NOMENCLATURE



MULTI V Water IV System Installation Manual

## Water Source Units

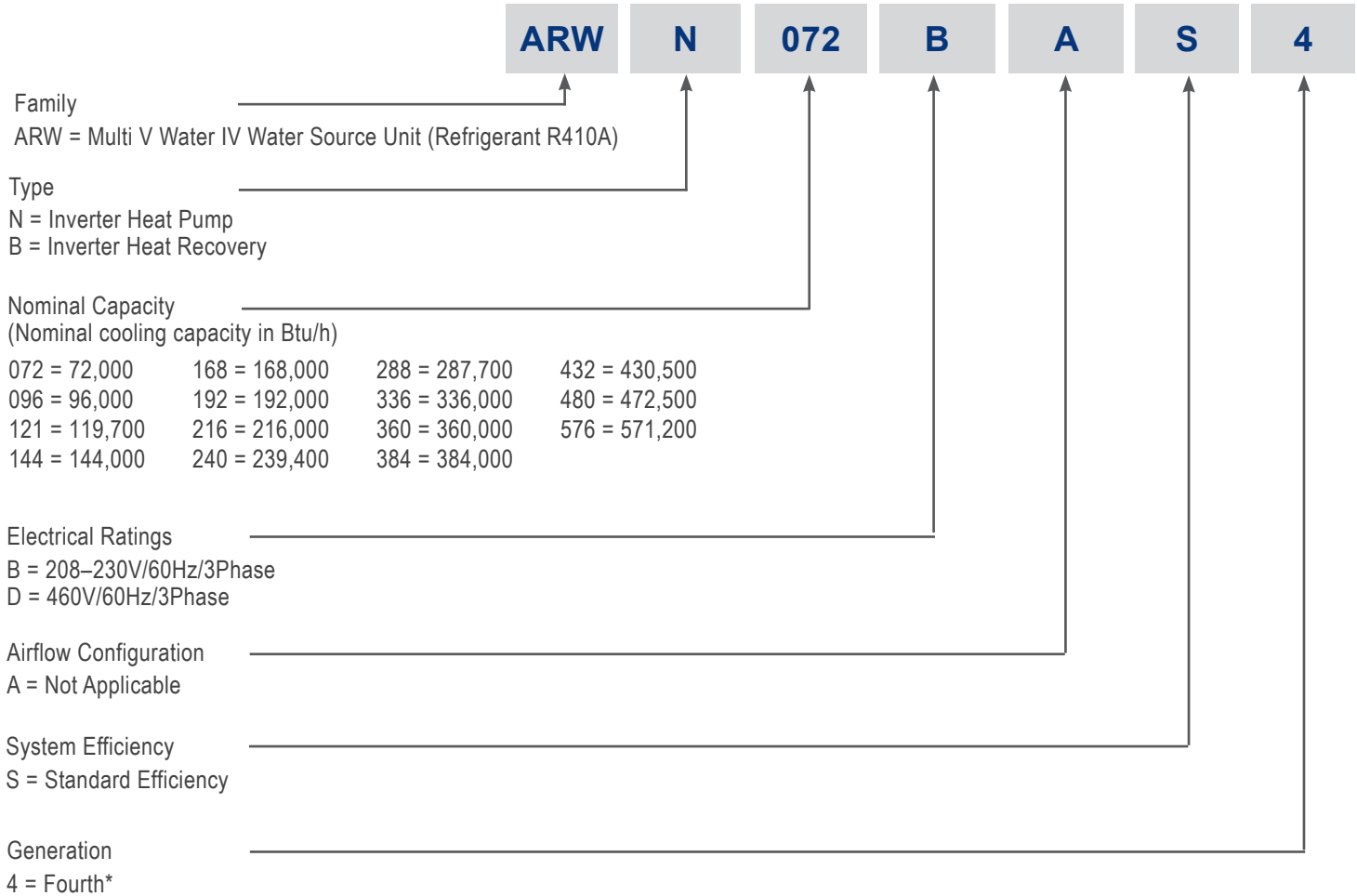

\*The latest versions of LG's indoor units and water source units are designated Generation 4 (Gen 4). For Gen 4 units to operate with Gen 4 features, the air conditioning system must meet the requirements listed on page 7.

## Heat Recovery Units (HRU)

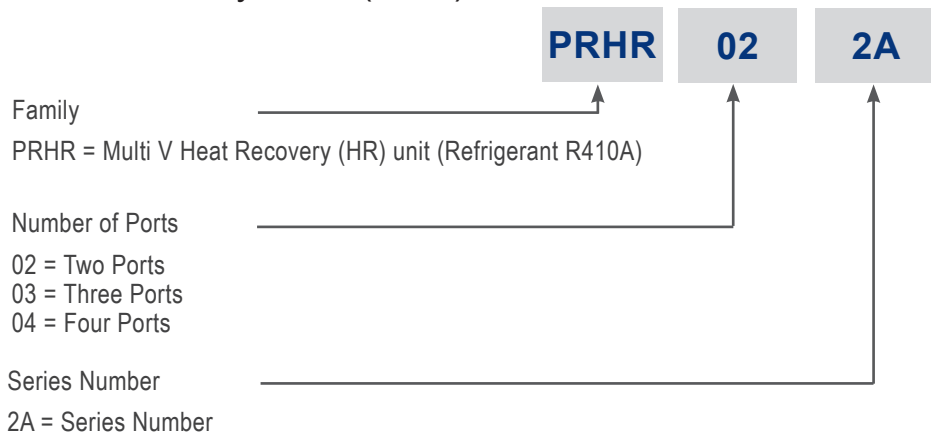



## ARWN Series Heat Pump Water Source Unit Specifications

Table 1: Single-Frame 208-230V Heat Pump Units.

Combination Unit Model Number	6.0 Ton ARWN072BAS4	8.0 Ton ARWN096BAS4	10.0 Ton ARWN121BAS4	12.0 ARWN144BAS4
Individual Component Model Numbers	-	-	-	-
<b>Cooling Performance</b>				
Nominal Cooling Capacity (Btu/h) <sup>1</sup>	72,000	96,000	119,700	144,000
<b>Heating Performance</b>				
Nominal Heating Capacity (Btu/h) <sup>1</sup>	81,000	108,000	135,000	162,000
<b>Operating Range (Entering Water Temperature)</b>				
Cooling (°F) <sup>2</sup>	23 – 113	23 – 113	23 – 113	23 – 113
Heating (°F)	14 – 113	14 – 113	14 – 113	14 – 113
<b>Compressor</b>				
Inverter Quantity	HSS DC Scroll x 1	HSS DC Scroll x 1	HSS DC Scroll x 1	HSS DC Scroll x 1
Oil/Type	PVE/FVC68D	PVE/FVC68D	PVE/FVC68D	PVE/FVC68D
<b>Unit Data</b>				
Refrigerant Type	R410A	R410A	R410A	R410A
R410A Refrigerant Factory Charge (lbs)	12.8	12.8	12.8	12.8
Refrigerant Control/Location	EEV/Indoor Unit	EEV/Indoor Unit	EEV/Indoor Unit	EEV/Indoor Unit
Max. Number Indoor Units/System	13	16	20	23
Sound Pressure dB(A) <sup>3</sup> Cooling/Heating	47/51	50/53	56/56	58/57
Net Unit Weight (lbs.)	280	280	280	280
Shipping Weight (lbs.)	302	302	302	302
Communication Cables	2 x 18 AWG	2 x 18 AWG	2 x 18 AWG	2 x 18 AWG
Heat Rejected to Equipment Room (Btu/h)	2,152	2,322	2,493	2,664
<b>Heat Exchanger (Stainless Steel Plate)</b>				
Maximum Pressure Resistance (psi)	640	640	640	640
Flow at Rated Condition (GPM)	20.3	25.4	30.4	35.5
Range of Flow (GPM)	8.1 – 30.5	10.2 – 38.1	12.2 – 45.6	14.2 – 53.3
Total Heat of Rejection (Btu/h)	94,400	126,700	157,400	190,100
Total Heat of Absorption (Btu/h)	73,200	96,800	122,000	145,200
Pressure Drop (ft-wg)	3.7	4.7	6.9	9.2
Δt <sup>4</sup> (°F)	9.3	10.0	10.4	10.7
<b>Piping<sup>5</sup></b>				
Liquid Line Connection (in., OD)	3/8 Braze	3/8 Braze	1/2 Braze	1/2 Braze
Vapor Line Connection (in., OD)	7/8 Braze	7/8 Braze	1-1/8 Braze	1-1/8 Braze
Water Inlet/Outlet Connection (in)	1-1/2 + 1-1/2 Fem	1-1/2 + 1-1/2 Fem	1-1/2 + 1-1/2 Fem	1-1/2 + 1-1/2 Fem
Condensate Drain (in)	3/4 Female	3/4 Female	3/4 Female	3/4 Female

<sup>1</sup>Nominal capacity is outside of AHRI Standard 1230 and based on the following conditions:

- Cooling – Indoor 80°F DB / 66°F WB  
Water Temperature Entering: 86°F
- Heating – Indoor 68°F DB  
Water Temperature Entering: 68°F

<sup>2</sup>When entering water temperature is lower than 59°F, variable water flow control kit PWFCCKN000 is required.

<sup>3</sup>Sound pressure levels are tested in an anechoic chamber under ISO 3745 standard.

<sup>4</sup>Value is calculated as follows: Δt = Total Heat of Rejection/(Nominal Flow Rate x 500).

<sup>5</sup>Refer to the Refrigerant Piping section of this manual for correct line sizing. Contractor must use LG manufactured Y-Branch and Header Kits only. Designer must verify refrigerant piping design configuration using LG's computerized refrigerant piping software (LATS Multi V) to validate the pipe design.

# GENERAL DATA



## ARWN Series Heat Pump Water Source Unit Specifications

Table 2: Dual-Frame 208-230V Heat Pump Units.

Combination Unit Model Number	14.0 Ton ARWN168BAS4	16.0 Ton ARWN192BAS4	18.0 Ton ARWN216BAS4	24.0 Ton ARWN288BAS4
Individual Component Model Numbers	ARWN072BAS4 x 1 + ARWN096BAS4 x 1	ARWN072BAS4 x 1 + ARWN121BAS4 x 1	ARWN072BAS4 x 1 + ARWN144BAS4 x 1	ARWN144BAS4 x 2
<i>Cooling Performance</i>				
Nominal Cooling Capacity (Btu/h) <sup>1</sup>	168,000	192,000	216,000	287,700
<i>Heating Performance</i>				
Nominal Heating Capacity (Btu/h) <sup>1</sup>	189,000	216,000	243,000	324,000
<i>Operating Range (Entering Water Temperature)</i>				
Cooling (°F) <sup>2</sup>	23 – 113	23 – 113	23 – 113	23 – 113
Heating (°F)	14 – 113	14 – 113	14 – 113	14 – 113
<i>Compressor</i>				
Inverter Quantity	HSS DC Scroll x 2	HSS DC Scroll x 2	HSS DC Scroll x 2	HSS DC Scroll x 2
Oil/Type	PVE/FVC68D	PVE/FVC68D	PVE/FVC68D	PVE/FVC68D
<i>Unit Data</i>				
Refrigerant Type	R410A	R410A	R410A	R410A
R410A Refrigerant Factory Charge (lbs)	12.8 + 12.8	12.8 + 12.8	12.8 + 12.8	12.8 + 12.8
Refrigerant Control/Location	EEV/Indoor Unit	EEV/Indoor Unit	EEV/Indoor Unit	EEV/Indoor Unit
Max. Number Indoor Units/System	29	32	35	45
Sound Pressure dB(A) <sup>3</sup> Cooling/Heating	55/56	54/60	57/57	59/58
Net Unit Weight (lbs.)	280 + 280	280 + 280	280 + 280	280 + 280
Shipping Weight (lbs.)	302 + 302	302 + 302	302 + 302	302 + 302
Communication Cables	2 x 18 AWG	2 x 18 AWG	2 x 18 AWG	2 x 18 AWG
Heat Rejected to Equipment Room (Btu/h)	4,304	4,645	4,816	5,328
<i>Heat Exchanger (Stainless Steel Plate)</i>				
Maximum Pressure Resistance (psi)	640	640	640	640
Flow at Rated Condition (GPM)	25.4 + 20.3	30.4 + 20.3	35.5 + 20.3	35.5 + 35.5
Range of Flow (GPM)	18.3 – 68.6	20.3 – 76.1	22.3 – 83.7	28.4 – 106.5
Total Heat of Rejection (Btu/h)	94,400 + 126,700	94,400 + 157,400	94,400 + 190,100	190,100 + 190,100
Total Heat of Absorption (Btu/h)	73,200 + 96,800	73,200 + 122,000	73,200 + 145,200	145,200 + 145,200
Pressure Drop (ft-wg)	3.7 + 4.7	3.7 + 6.9	3.7 + 9.2	9.2 + 9.2
Δt <sup>4</sup> (°F)	9.7	9.9	10.2	10.7
<i>Piping<sup>5</sup></i>				
Liquid Line Connection (in., OD)	3/8 + 3/8 Braze	3/8 + 1/2 Braze	3/8 + 1/2 Braze	1/2 + 1/2 Braze
Vapor Line Connection (in., OD)	7/8 + 7/8 Braze	7/8 + 1-1/8 Braze	7/8 + 1-1/8 Braze	1-1/8 + 1-1/8 Braze
Water Inlet/Outlet Connection (in)	(1-1/2 + 1-1/2 Fem) x2	(1-1/2 + 1-1/2 Fem) x2	(1-1/2 + 1-1/2 Fem) x2	(1-1/2 + 1-1/2 Fem) x2
Condensate Drain (in)	3/4 Female	3/4 Female	3/4 Female	3/4 Female

<sup>1</sup>Nominal capacity is outside of AHRI Standard 1230 and based on the following conditions:

- Cooling – Indoor 80°F DB / 66°F WB  
Water Temperature Entering: 86°F
- Heating – Indoor 68°F DB  
Water Temperature Entering: 68°F

<sup>2</sup>When entering water temperature is lower than 59°F, variable water flow control kit PWFCKN000 is required.

<sup>3</sup>Sound pressure levels are tested in an anechoic chamber under ISO 3745 standard.

<sup>4</sup>Value is calculated as follows: Δt = Total Heat of Rejection/(Nominal Flow Rate x 500).

<sup>5</sup>Refer to the Refrigerant Piping section of this manual for correct line sizing. Contractor must use LG manufactured Y-Branch and Header Kits only. Designer must verify refrigerant piping design configuration using LG's computerized refrigerant piping software (LATS Multi V) to validate the pipe design.

## ARWN Series Heat Pump Water Source Unit Specifications

Table 3: Triple-Frame 208-230V Heat Pump Units.

Combination Unit Model Number	30.0 Ton ARWN360BAS4	36.0 Ton ARWN432BAS4
Individual Component Model Numbers	ARWN072BAS4 x 1 + ARWN144BAS4 x 2	ARWN144BAS4 x 3
<i>Cooling Performance</i>		
Nominal Cooling Capacity (Btu/h) <sup>1</sup>	359,100	430,500
<i>Heating Performance</i>		
Nominal Heating Capacity (Btu/h) <sup>1</sup>	405,000	486,000
<i>Operating Range (Entering Water Temperature)</i>		
Cooling (°F) <sup>2</sup>	23 – 113	23 – 113
Heating (°F)	14 – 113	14 – 113
<i>Compressor</i>		
Inverter Quantity	HSS DC Scroll x 3	HSS DC Scroll x 3
Oil/Type	PVE/FVC68D	PVE/FVC68D
<i>Unit Data</i>		
Refrigerant Type	R410A	R410A
R410A Refrigerant Factory Charge (lbs)	12.8 + 12.8 + 12.8	12.8 + 12.8 + 12.8
Refrigerant Control/Location	EEV/Indoor Unit	EEV/Indoor Unit
Max. Number Indoor Units/System	58	64
Sound Pressure dB(A) <sup>3</sup> Cooling/Heating	56/57	58/62
Net Unit Weight (lbs.)	280 + 280 + 280	280 + 280 + 280
Shipping Weight (lbs.)	302 + 302 + 302	302 + 302 + 302
Communication Cables	2 x 18 AWG	2 x 18 AWG
Heat Rejected to Equipment Room (Btu/h)	7,480	7,992
<i>Heat Exchanger (Stainless Steel Plate)</i>		
Maximum Pressure Resistance (psi)	640	640
Flow at Rated Condition (GPM)	20.3 + 35.5 + 35.5	35.5 + 35.5 + 35.5
Range of Flow (GPM)	36.5 – 137	42.6 – 159.8
Total Heat of Rejection (Btu/h)	94,400 + 190,100 + 190,100	190,100 + 190,100 + 190,100
Total Heat of Absorption (Btu/h)	73,200 + 145,200 + 145,200	145,200 + 145,200 + 145,200
Pressure Drop (ft-wg)	3.7 + 9.2 + 9.2	9.2 + 9.2 + 9.2
Δt <sup>4</sup> (°F)	10.4	10.7
<i>Piping<sup>5</sup></i>		
Liquid Line Connection (in., OD)	3/8 + 1/2+1/2 Braze	1/2+1/2+1/2 Braze
Vapor Line Connection (in., OD)	7/8 + 1-1/8 +1-1/8 Braze	1-1/8 +1-1/8 + 1-1/8 Braze
Water Inlet/Outlet Connection Size (in)	(1-1/2 + 1-1/2 Female) x3	(1-1/2 + 1-1/2 Female) x3
Condensate Drain (in)	3/4 Female	3/4 Female

<sup>1</sup>Nominal capacity is outside of AHRI Standard 1230 and based on the following conditions:

- Cooling – Indoor 80°F DB / 66°F WB  
Water Temperature Entering: 86°F
- Heating – Indoor 68°F DB  
Water Temperature Entering: 68°F

<sup>2</sup>When entering water temperature is lower than 59°F, variable water flow control kit PWFCKN000 is required.

<sup>3</sup>Sound pressure levels are tested in an anechoic chamber under ISO 3745 standard.

<sup>4</sup>Value is calculated as follows: Δt = Total Heat of Rejection/(Nominal Flow Rate x 500).

<sup>5</sup>Refer to the Refrigerant Piping section of this manual for correct line sizing. Contractor must use LG manufactured Y-Branch and Header Kits only. Designer must verify refrigerant piping design configuration using LG's computerized refrigerant piping software (LATS Multi V) to validate the pipe design.

# GENERAL DATA



## ARWN Series Heat Pump Water Source Unit Specifications

Table 4: Single-Frame 460V Heat Pump Units.

Combination Unit Model Number	6.0 Ton ARWN072DAS4	8.0 Ton ARWN096DAS4	10.0 Ton ARWN121DAS4	12.0 Ton ARWN144DAS4	14.0 Ton ARWN168DAS4	16.0 Ton ARWN192DAS4
Individual Component Model Numbers	-	-	-	-	-	-
<b>Cooling Performance</b>						
Nominal Cooling Capacity (Btu/h) <sup>1</sup>	72,000	96,000	119,700	144,000	168,000	192,000
<b>Heating Performance</b>						
Nominal Heating Capacity (Btu/h) <sup>1</sup>	81,000	108,000	135,000	162,000	189,000	216,000
<b>Operating Range (Entering Water Temperature)</b>						
Cooling (°F) <sup>2</sup>	23 – 113	23 – 113	23 – 113	23 – 113	23 – 113	23 – 113
Heating (°F)	14 – 113	14 – 113	14 – 113	14 – 113	14 – 113	14 – 113
<b>Compressor</b>						
Inverter Quantity	HSS DC Scroll x 1	HSS DC Scroll x 1	HSS DC Scroll x 1	HSS DC Scroll x 1	HSS DC Scroll x 1	HSS DC Scroll x 1
Oil/Type	PVE/FVC68D	PVE/FVC68D	PVE/FVC68D	PVE/FVC68D	PVE/FVC68D	PVE/FVC68D
<b>Unit Data</b>						
Refrigerant Type	R410A	R410A	R410A	R410A	R410A	R410A
R410A Refrigerant Factory Charge (lbs)	12.8	12.8	12.8	6.6	6.6	6.6
Refrigerant Control/Location	EEV/Indoor Unit	EEV/Indoor Unit	EEV/Indoor Unit	EEV/Indoor Unit	EEV/Indoor Unit	EEV/Indoor Unit
Max. Number Indoor Units/System	13	16	20	23	29	32
Sound Pressure dB(A) Cooling/Heating	47/51	50/53	56/56	58/57	53/57	54/60
Net Unit Weight (lbs.)	280	280	280	309	309	309
Shipping Weight (lbs.)	302	302	302	331	331	331
Communication Cables	2 x 18 AWG	2 x 18 AWG	2 x 18 AWG	2 x 18 AWG	2 x 18 AWG	2 x 18 AWG
Heat Rejected to Equipment Room (Btu/h)	2,152	2,322	2,493	2,357	2,459	2,561
<b>Heat Exchanger (Stainless Steel Plate)</b>						
Maximum Pressure Resistance (psi)	640	640	640	640	640	640
Flow at Rated Condition (GPM)	20.3	25.4	30.4	35.5	45.7	50.7
Range of Flow (GPM)	8.1 – 30.5	10.2 – 38.1	12.2 – 45.6	14.2 – 53.3	18.3 – 68.6	20.3 – 76.1
Total Heat of Rejection (Btu/h)	94,100	125,900	157,900	190,100	221,100	253,500
Total Heat of Absorption (Btu/h)	74,200	98,600	122,700	146,800	170,100	193,600
Pressure Drop (ft-wg)	3.7	4.7	6.9	4.7	8.0	9.2
Δt <sup>4</sup> (°F)	9.3	9.9	10.3	10.7	9.7	10.0
<b>Piping<sup>5</sup></b>						
Liquid Line Connection (in., OD)	3/8 Braze	3/8 Braze	1/2 Braze	1/2 Braze	1/2 Braze	1/2 Braze
Vapor Line Connection (in., OD)	7/8 Braze	7/8 Braze	1-1/8 Braze	1-1/8 Braze	1-1/8 Braze	1-1/8 Braze
Water Inlet/Outlet Connection (in)	1-1/2 + 1-1/2 Fem	1-1/2 + 1-1/2 Fem	1-1/2 + 1-1/2 Fem	1-1/2 + 1-1/2 Fem	1-1/2 + 1-1/2 Fem	1-1/2 + 1-1/2 Fem
Condensate Drain (in)	3/4 Female	3/4 Female	3/4 Female	3/4 Female	3/4 Female	3/4 Female

<sup>1</sup>Nominal capacity is outside of AHRI Standard 1230 and based on the following conditions:

- Cooling – Indoor 80°F DB / 66°F WB  
Water Temperature Entering: 86°F
- Heating – Indoor 68°F DB  
Water Temperature Entering: 68°F

<sup>2</sup>When entering water temperature is lower than 59°F, variable water flow control kit PWFCCKN000 is required.

<sup>3</sup>Sound pressure levels are tested in an anechoic chamber under ISO 3745 standard.

<sup>4</sup>Value is calculated as follows: Δt = Total Heat of Rejection/(Nominal Flow Rate x 500).

<sup>5</sup>Refer to the Refrigerant Piping section of this manual for correct line sizing. Contractor must use LG manufactured Y-Branch and Header Kits only. Designer must verify refrigerant piping design configuration using LG's computerized refrigerant piping software (LATS Multi V) to validate the pipe design.

## ARWN Series Heat Pump Water Source Unit Specifications

Table 5: Dual-Frame 460V Heat Pump Units.

Combination Unit Model Number	20.0 Ton ARWN240DAS4	24.0 Ton ARWN288DAS4	28.0 Ton ARWN336DAS4	32.0 Ton ARWN384DAS4
Individual Component Model Numbers	ARWN096DAS4 + ARWN144DAS4	ARWN121DAS4 + ARWN168DAS4	ARWN168DAS4 x 2	ARWN192DAS4 x 2
<i>Cooling Performance</i>				
Nominal Cooling Capacity (Btu/h) <sup>1</sup>	239,400	287,700	336,000	384,000
<i>Heating Performance</i>				
Nominal Heating Capacity (Btu/h) <sup>1</sup>	270,000	324,000	378,000	432,000
<i>Operating Range (Entering Water Temperature)</i>				
Cooling (°F) <sup>2</sup>	23 – 113	23 – 113	23 – 113	23 – 113
Heating (°F)	23 – 113	23 – 113	23 – 113	23 – 113
<i>Compressor</i>				
Inverter Quantity	HSS DC Scroll x 2	HSS DC Scroll x 2	HSS DC Scroll x 2	HSS DC Scroll x 2
Oil/Type	PVE/FVC68D	PVE/FVC68D	PVE/FVC68D	PVE/FVC68D
<i>Unit Data</i>				
Refrigerant Type	R410A	R410A	R410A	R410A
R410A Refrigerant Factory Charge (lbs)	12.8 + 6.6	12.8 + 6.6	6.6 + 6.6	6.6 + 6.6
Refrigerant Control/Location	EEV/Indoor Unit	EEV/Indoor Unit	EEV/Indoor Unit	EEV/Indoor Unit
Max. Number Indoor Units/System	39	45	55	61
Sound Pressure dB(A) <sup>3</sup> Cooling/Heating	57/57	59/58	59/61	56/61
Net Unit Weight (lbs.)	280 + 309	280 + 309	309 + 309	309 + 309
Shipping Weight (lbs.)	302 + 331	302 + 331	331 + 331	331 + 331
Communication Cables	2 x 18 AWG	2 x 18 AWG	2 x 18 AWG	2 x 18 AWG
Heat Rejected to Equipment Room (Btu/h)	4,679	4,952	4,918	5122
<i>Heat Exchanger (Stainless Steel Plate)</i>				
Maximum Pressure Resistance (psi)	640	640	640	640
Flow at Rated Condition (GPM)	25.4 + 35.5	30.4 + 45.7	45.7 + 45.7	50.7 + 50.7
Range of Flow (GPM)	24.4 – 91.4	30.4 – 114.2	36.6 – 171.4	40.6 – 152.1
Total Heat of Rejection (Btu/h)	125,900 + 190,100	157,900 + 221,100	221,100 x 2	253,500 x 2
Total Heat of Absorption (Btu/h)	98,600 + 146,800	122,700 + 170,100	170,100 x 2	193,600 x 2
Pressure Drop (ft-wg)	4.7 + 4.7	6.9 + 8.0	8.0 + 8.0	9.2 + 9.2
Δt <sup>4</sup> (°F)	10.4	10.0	9.7	10.0
<i>Piping<sup>5</sup></i>				
Liquid Line Connection (in., OD)	3/8 + 1/2 Braze	1/2 + 1/2 Braze	1/2 + 1/2 Braze	1/2 + 1/2 Braze
Vapor Line Connection (in., OD)	7/8 + 1-1/8 Braze	7/8 + 1-1/8 Braze	1-1/8 + 1-1/8 Braze	1-1/8 + 1-1/8 Braze
Water Inlet/Outlet Connection Size (in)	(1-1/2 + 1-1/2 Fem) x2	(1-1/2 + 1-1/2 Fem) x2	(1-1/2 + 1-1/2 Fem) x2	(1-1/2 + 1-1/2 Fem) x2
Condensate Drain (in)	3/4 Female	3/4 Female	3/4 Female	3/4 Female

<sup>1</sup>Nominal capacity is outside of AHRI Standard 1230 and based on the following conditions:

- Cooling – Indoor 80°F DB / 66°F WB  
Water Temperature Entering: 86°F
- Heating – Indoor 68°F DB  
Water Temperature Entering: 68°F

<sup>2</sup>When entering water temperature is lower than 59°F, variable water flow control kit PWFCKN000 is required.

<sup>3</sup>Sound pressure levels are tested in an anechoic chamber under ISO 3745 standard.

<sup>4</sup>Value is calculated as follows: Δt = Total Heat of Rejection/(Nominal Flow Rate x 500).

<sup>5</sup>Refer to the Refrigerant Piping section of this manual for correct line sizing. Contractor must use LG manufactured Y-Branch and Header Kits only. Designer must verify refrigerant piping design configuration using LG's computerized refrigerant piping software (LATS Multi V) to validate the pipe design.

# GENERAL DATA



## ARWN Series Heat Pump Water Source Unit Specifications

Table 6: Triple-Frame 460V Heat Pump Units

Combination Unit Model Number	40.0 Ton ARWN480DAS4	48.0 Ton ARWN576DAS4
Individual Component Model Numbers	ARWN144DAS4 x 2 + ARWN192DAS4 x 1	ARWN192DAS4 x 3
<i>Cooling Performance</i>		
Nominal Cooling Capacity (Btu/h) <sup>1</sup>	472,500	571,200
<i>Heating Performance</i>		
Nominal Heating Capacity (Btu/h) <sup>1</sup>	540,000	648,000
<i>Operating Range (Entering Water Temperature)</i>		
Cooling (°F) <sup>2</sup>	23 – 113	23 – 113
Heating (°F)	14 – 113	14 – 113
<i>Compressor</i>		
Inverter Quantity	HSS DC Scroll x 3	HSS DC Scroll x 3
Oil/Type	PVE/FVC68D	PVE/FVC68D
<i>Unit Data</i>		
Refrigerant Type	R410A	R410A
R410A Refrigerant Factory Charge (lbs)	6.6 + 6.6 + 6.6	6.6 + 6.6 + 6.6
Refrigerant Control/Location	EEV/Indoor Unit	EEV/Indoor Unit
Max. Number Indoor Units/System	64	64
Sound Pressure dB(A) <sup>3</sup> Cooling/Heating	60/62	60/62
Net Unit Weight (lbs.)	309 x 3	309 x 3
Shipping Weight (lbs.)	331 x 3	331 x 3
Communication Cables	2 x 18 AWG	2 x 18 AWG
Heat Rejected to Equipment Room (Btu/h)	7,275	7863
<i>Heat Exchanger (Stainless Steel Plate)</i>		
Maximum Pressure Resistance (psi)	640	640
Flow at Rated Condition (GPM)	35.5 + 35.5 + 50.7	50.7 + 50.7 + 50.7
Range of Flow (GPM)	48.7 – 182.6	60.8 – 228.2
Total Heat of Rejection (Btu/h)	190,100 + 190,100 + 253,500	253,500 + 253,500 + 253,500
Total Heat of Absorption (Btu/h)	146,800 + 146,800 + 193,600	193,600 + 193,600 + 193,600
Pressure Drop (ft-wg)	4.7 + 4.7 + 9.2	9.2 + 9.2 + 9.2
Δt <sup>4</sup> (°F)	10.4	10.0
<i>Piping<sup>5</sup></i>		
Liquid Line Connection (in., OD)	1/2 + 1/2 + 1/2 Braze	1/2 + 1/2 + 1/2 Braze
Vapor Line Connection (in., OD)	1-1/8 + 1-1/8 + 1-1/8 Braze	1-1/8 + 1-1/8 + 1-1/8 Braze
Water Inlet/Outlet Connection Size (in)	(1-1/2 + 1-1/2 Fem) x3	(1-1/2 + 1-1/2 Fem) x3
Condensate Drain (in)	3/4 Female	3/4 Female

<sup>1</sup>Nominal capacity is outside of AHRI Standard 1230 and based on the following conditions:

- Cooling – Indoor 80°F DB / 66°F WB  
Water Temperature Entering: 86°F
- Heating – Indoor 68°F DB  
Water Temperature Entering: 68°F

<sup>2</sup>When entering water temperature is lower than 59°F, variable water flow control kit PWFCKN000 is required.

<sup>3</sup>Sound pressure levels are tested in an anechoic chamber under ISO 3745 standard.

<sup>4</sup>Value is calculated as follows: Δt = Total Heat of Rejection/(Nominal Flow Rate x 500).

<sup>5</sup>Refer to the Refrigerant Piping section of this manual for correct line sizing. Contractor must use LG manufactured Y-Branch and Header Kits only. Designer must verify refrigerant piping design configuration using LG's computerized refrigerant piping software (LATS Multi V) to validate the pipe design.

## ARWB Series Heat Recovery Water Source Unit Specifications

Table 7: Single-Frame 208-230V Heat Recovery Units.

Combination Unit Model Number	6.0 Ton ARWB072BAS4	8.0 Ton ARWB096BAS4	10.0 Ton ARWB121BAS4	12.0 ARWB144BAS4
Individual Component Model Numbers	-	-	-	-
<i>Cooling Performance</i>				
Nominal Cooling Capacity (Btu/h) <sup>1</sup>	72,000	96,000	119,700	144,000
<i>Heating Performance</i>				
Nominal Heating Capacity (Btu/h) <sup>1</sup>	81,000	108,000	135,000	162,000
<i>Operating Range (Entering Water Temperature)</i>				
Cooling (°F) <sup>2</sup>	23 – 113	23 – 113	23 – 113	23 – 113
Heating (°F)	23 – 113	23 – 113	23 – 113	23 – 113
Synchronous Operation (°F)	23 – 113	23 – 113	23 – 113	23 – 113
<i>Compressor</i>				
Inverter Quantity	HSS DC Scroll x1	HSS DC Scroll x1	HSS DC Scroll x1	HSS DC Scroll x1
Oil/Type	PVE/FVC68D	PVE/FVC68D	PVE/FVC68D	PVE/FVC68D
<i>Unit Data</i>				
Refrigerant Type	R410A	R410A	R410A	R410A
R410A Refrigerant Factory Charge (lbs)	12.8	12.8	12.8	12.8
Refrigerant Control/Location	EEV/Indoor Unit	EEV/Indoor Unit	EEV/Indoor Unit	EEV/Indoor Unit
Max. Number Indoor Units/System	13	16	20	23
Sound Pressure dB(A) <sup>3</sup> Cooling/Heating	47/51	50/53	56/56	58/57
Net Unit Weight (lbs.)	280	280	280	280
Shipping Weight (lbs.)	302	302	302	302
Communication Cables	2 x 18 AWG	2 x 18 AWG	2 x 18 AWG	2 x 18 AWG
Heat Rejected to Equipment Room (Btu/h)	2,152	2,322	2,493	2,664
<i>Heat Exchanger (Stainless Steel Plate)</i>				
Maximum Pressure Resistance (psi)	640	640	640	640
Flow at Rated Condition (GPM)	20.3	25.4	30.4	35.5
Range of Flow (GPM)	8.1 – 30.5	10.2 – 38.1	12.2 – 45.6	14.2 – 53.3
Total Heat of Rejection (Btu/h)	94,400	126,700	157,400	190,100
Total Heat of Absorption (Btu/h)	73,200	96,800	122,000	145,200
Pressure Drop (ft-wg)	3.7	4.7	6.9	9.2
Δt <sup>4</sup> (°F)	9.3	9.9	10.3	10.7
<i>Piping<sup>5</sup></i>				
Liquid Line Connection (in., OD)	3/8 Braze	3/8 Braze	1/2 Braze	1/2 Braze
Low Press Vapor Line Conn (in., OD)	7/8 Braze	7/8 Braze	1-1/8 Braze	1-1/8 Braze
High Press Vapor Line Conn (in., OD)	3/4 Braze	3/4 Braze	3/4 Braze	3/4 Braze
Water Inlet/Outlet Connection (in)	1-1/2 + 1-1/2 Fem	1-1/2 + 1-1/2 Fem	1-1/2 + 1-1/2 Fem	1-1/2 + 1-1/2 Fem
Condensate Drain (in)	3/4 Female	3/4 Female	3/4 Female	3/4 Female

<sup>1</sup>Nominal capacity is outside of AHRI Standard 1230 and based on the following conditions:

- Cooling – Indoor 80°F DB / 66°F WB  
Water Temperature Entering: 86°F
- Heating – Indoor 68°F DB  
Water Temperature Entering: 68°F

<sup>2</sup>When entering water temperature is lower than 59°F, variable water flow control kit PWFCCKN000 is required.

<sup>3</sup>Sound pressure levels are tested in an anechoic chamber under ISO 3745 standard.

<sup>4</sup>Value is calculated as follows: Δt = Total Heat of Rejection/(Nominal Flow Rate x 500).

<sup>5</sup>Refer to the Refrigerant Piping section of this manual for correct line sizing. Contractor must use LG manufactured Y-Branch and Header Kits only. Designer must verify refrigerant piping design configuration using LG's computerized refrigerant piping software (LATS Multi V) to validate the pipe design.

# GENERAL DATA



## ARWB Series Heat Recovery Water Source Unit Specifications

Table 8: Dual-Frame 208-230V Heat Recovery Units.

Combination Unit Model Number	14.0 Ton ARWB168BAS4	16.0 Ton ARWB192BAS4	18.0 Ton ARWB216BAS4	24.0 Ton ARWB288BAS4
Individual Component Model Numbers	ARWB072BAS4 x 1 + ARWB096BAS4 x 1	ARWB072BAS4 x 1 + ARWB121BAS4 x 1	ARWB072BAS4 x 1 + ARWB144BAS4 x 1	ARWB144BAS4 x 2
<i>Cooling Performance</i>				
Nominal Cooling Capacity (Btu/h) <sup>1</sup>	168,000	192,000	216,000	287,700
<i>Heating Performance</i>				
Nominal Heating Capacity (Btu/h) <sup>1</sup>	189,000	216,000	243,000	324,000
<i>Operating Range (Entering Water Temperature)</i>				
Cooling (°F) <sup>2</sup>	23 – 113	23 – 113	23 – 113	23 – 113
Heating (°F)	14 – 113	14 – 113	14 – 113	14 – 113
Synchronous Operation (°F)	23 – 113	23 – 113	23 – 113	23 – 113
<i>Compressor</i>				
Inverter Quantity	HSS DC Scroll x 2	HSS DC Scroll x 2	HSS DC Scroll x 2	HSS DC Scroll x 2
Oil/Type	PVE/FVC68D	PVE/FVC68D	PVE/FVC68D	PVE/FVC68D
<i>Unit Data</i>				
Refrigerant Type	R410A	R410A	R410A	R410A
R410A Refrigerant Factory Charge (lbs)	12.8 + 12.8	12.8 + 12.8	12.8 + 12.8	12.8 + 12.8
Refrigerant Control/Location	EEV/Indoor Unit	EEV/Indoor Unit	EEV/Indoor Unit	EEV/Indoor Unit
Max. Number Indoor Units/System	29	32	35	45
Sound Press dB(A) <sup>3</sup> Cooling/Heating	55/56	54/60	57/57	59/58
Net Unit Weight (lbs.)	280 + 280	280 + 280	280 + 280	280 + 280
Shipping Weight (lbs.)	302 + 302	302 + 302	302 + 302	302 + 302
Communication Cables	2 x 18 AWG	2 x 18 AWG	2 x 18 AWG	2 x 18 AWG
Heat Rejected to Equipment Room (Btu/h)	4,304	4,645	4,816	5,328
<i>Heat Exchanger (Stainless Steel Plate)</i>				
Maximum Pressure Resistance (psi)	640	640	640	640
Flow at Rated Condition (GPM)	25.4 + 20.3	30.4 + 20.3	35.5 + 20.3	35.5 + 35.5
Range of Flow (GPM)	18.3 – 68.6	20.3 – 76.1	22.3 – 83.7	28.4 – 106.5
Total Heat of Rejection (Btu/h)	94,400 + 126,700	94,400 + 157,400	94,400 + 190,100	190,100 + 190,100
Total Heat of Absorption (Btu/h)	73,200 + 96,800	73,200 + 122,000	73,200 + 145,200	145,200 + 145,200
Pressure Drop (ft-wg)	3.7 + 4.7	3.7 + 6.9	3.7 + 9.2	9.2 + 9.2
Δt <sup>4</sup> (°F)	9.6	9.9	10.2	10.7
<i>Piping<sup>5</sup></i>				
Liquid Line Connection (in., OD)	3/8 + 3/8 Braze	1/2 + 3/8 Braze	1/2 + 3/8 Braze	1/2 + 1/2 Braze
Low Press Vapor Line Conn (in., OD)	7/8 + 7/8 Braze	7/8 + 1-1/8 Braze	7/8 + 1-1/8 Braze	1-1/8 + 1-1/8 Braze
High Press Vapor Line Conn (in., OD)	3/4 + 3/4 Braze	3/4 + 3/4 Braze	3/4 + 3/4 Braze	3/4 + 3/4 Braze
Water Inlet/Outlet Connection (in)	(1-1/2 + 1-1/2 Fem) x2	(1-1/2 + 1-1/2 Fem) x2	(1-1/2 + 1-1/2 Fem) x2	(1-1/2 + 1-1/2 Fem) x2
Condensate Drain (in)	3/4 Female	3/4 Female	3/4 Female	3/4 Female

<sup>1</sup>Nominal capacity is outside of AHRI Standard 1230 and based on the following conditions:

- Cooling – Indoor 80°F DB / 66°F WB  
Water Temperature Entering: 86°F
- Heating – Indoor 68°F DB  
Water Temperature Entering: 68°F

<sup>2</sup>When entering water temperature is lower than 59°F, variable water flow control kit PWFCCKN000 is required.

<sup>3</sup>Sound pressure levels are tested in an anechoic chamber under ISO 3745 standard.

<sup>4</sup>Value is calculated as follows: Δt = Total Heat of Rejection/(Nominal Flow Rate x 500).

<sup>5</sup>Refer to the Refrigerant Piping section of this manual for correct line sizing. Contractor must use LG manufactured Y-Branch and Header Kits only. Designer must verify refrigerant piping design configuration using LG's computerized refrigerant piping software (LATS Multi V) to validate the pipe design.



## ARWB Series Heat Recovery Water Source Unit Specifications

Table 9: Triple-Frame 208-230V Heat Recovery Units.

Combination Unit Model Number	30.0 Ton ARWB360BAS4	36.0 Ton ARWB432BAS4
Individual Component Model Numbers	ARWB072BAS4 x 1 + ARWB144BAS4 x 2	ARWB144BAS4 x 3
<i>Cooling Performance</i>		
Nominal Cooling Capacity (Btu/h) <sup>1</sup>	359,100	430,500
<i>Heating Performance</i>		
Nominal Heating Capacity (Btu/h) <sup>1</sup>	405,000	486,000
<i>Operating Range (Entering Water Temperature)</i>		
Cooling (°F) <sup>2</sup>	23 – 113	23 – 113
Heating (°F)	14 – 113	14 – 113
Synchronous Operation (°F)	23 – 113	23 – 113
<i>Compressor</i>		
Inverter Quantity	HSS DC Scroll x 3	HSS DC Scroll x 3
Oil/Type	PVE/FVC68D	PVE/FVC68D
<i>Unit Data</i>		
Refrigerant Type	R410A	R410A
R410A Refrigerant Factory Charge (lbs)	12.8 + 12.8 + 12.8	12.8 + 12.8 + 12.8
Refrigerant Control/Location	EEV/Indoor Unit	EEV/Indoor Unit
Max. Number Indoor Units/System <sup>2</sup>	58	64
Sound Pressure dB(A) <sup>3</sup> Cooling/Heating	56/57	58/62
Net Unit Weight (lbs.)	280 + 280 + 280	280 + 280 + 280
Shipping Weight (lbs.)	302 + 302 + 302	302 + 302 + 302
Communication Cables	2 x 18 AWG	2 x 18 AWG
Heat Rejected to Equipment Room (Btu/h)	7,480	7,992
<i>Heat Exchanger (Stainless Steel Plate)</i>		
Maximum Pressure Resistance (psi)	640	640
Flow at Rated Condition (GPM)	35.5 + 35.5 + 20.3	35.5 + 35.5 + 35.5
Range of Flow (GPM)	36.5 – 137.0	42.6 – 159.8
Total Heat of Rejection (Btu/h)	94,400 + 190,100 + 190,100	190,100 + 190,100 + 190,100
Total Heat of Absorption (Btu/h)	73,200 + 145,200 + 145,200	145,200 + 145,200 + 145,200
Pressure Drop (ft-wg)	3.7 + 9.2 + 9.2	9.2 + 9.2 + 9.2
Δt <sup>4</sup> (°F)	10.4	10.7
<i>Piping<sup>5</sup></i>		
Liquid Line Connection (in., OD)	3/8 + 1/2 + 1/2 Braze	1/2 + 1/2 + 1/2 Braze
Low Pressure Vapor Line Conn (in., OD)	7/8 + 1-1/8 + 1-1/8 Braze	1-1/8 + 1-1/8 + 1-1/8 Braze
High Pressure Vapor Line Conn (in., OD)	3/4 + 3/4 + 3/4 Braze	3/4 + 3/4 + 3/4 Braze
Water Inlet/Outlet Connection Size (in)	(1-1/2 + 1-1/2 Fem) x3	(1-1/2 + 1-1/2 Fem) x3
Condensate Drain (in)	3/4 Female	3/4 Female

<sup>1</sup>Nominal capacity is outside of AHRI Standard 1230 and based on the following conditions:

- Cooling – Indoor 80°F DB / 66°F WB  
Water Temperature Entering: 86°F
- Heating – Indoor 68°F DB  
Water Temperature Entering: 68°F

<sup>2</sup>When entering water temperature is lower than 59°F, variable water flow control kit PWFCKN000 is required.

<sup>3</sup>Sound pressure levels are tested in an anechoic chamber under ISO 3745 standard.

<sup>4</sup>Value is calculated as follows: Δt = Total Heat of Rejection/(Nominal Flow Rate x 500).

<sup>5</sup>Refer to the Refrigerant Piping section of this manual for correct line sizing. Contractor must use LG manufactured Y-Branch and Header Kits only. Designer must verify refrigerant piping design configuration using LG's computerized refrigerant piping software (LATS Multi V) to validate the pipe design.

# GENERAL DATA



## ARWB Series Heat Recovery Water Source Unit Specifications

Table 10: Single-Frame 460V Heat Recovery Units.

Combination Unit Model Number	6.0 Ton ARWB072DAS4	8.0 Ton ARWB096DAS4	10.0 Ton ARWB121DAS4	12.0 ARWB144DAS4	14.0 Ton ARWB168DAS4	16.0 Ton ARWB192DAS4
Individual Component Model Numbers	–	–	–	–	–	–
<b>Cooling Performance</b>						
Nominal Cooling Capacity (Btu/h) <sup>1</sup>	72,000	96,000	119,700	144,000	168,000	192,000
<b>Heating Performance</b>						
Nominal Heating Capacity (Btu/h) <sup>1</sup>	81,000	108,000	135,000	162,000	189,000	216,000
<b>Operating Range (Entering Water Temperature)</b>						
Cooling (°F) <sup>2</sup>	23 – 113	23 – 113	23 – 113	23 – 113	23 – 113	23 – 113
Heating (°F)	14 – 113	14 – 113	14 – 113	14 – 113	14 – 113	14 – 113
Synchronous Operation (°F)	23 – 113	23 – 113	23 – 113	23 – 113	23 – 113	23 – 113
<b>Compressor</b>						
Inverter Quantity	HSS DC Scroll x 1	HSS DC Scroll x 1	HSS DC Scroll x 1	HSS DC Scroll x 1	HSS DC Scroll x 1	HSS DC Scroll x 1
Oil/Type	PVE/FVC68D	PVE/FVC68D	PVE/FVC68D	PVE/FVC68D	PVE/FVC68D	PVE/FVC68D
<b>Unit Data</b>						
Refrigerant Type	R410A	R410A	R410A	R410A	R410A	R410A
R410A Refrigerant Factory Charge (lbs)	12.8	12.8	12.8	6.6	6.6	6.6
Refrigerant Control/Location	EEV/Indoor Unit	EEV/Indoor Unit	EEV/Indoor Unit	EEV/Indoor Unit	EEV/Indoor Unit	EEV/Indoor Unit
Max. Number Indoor Units/System <sup>2</sup>	13	16	20	23	29	32
Sound Press dB(A) <sup>3</sup> Cooling/Heating	47/51	50/53	56/56	58/57	53/57	54/60
Net Unit Weight (lbs.)	280	280	280	309	309	309
Shipping Weight (lbs.)	302	302	302	331	331	331
Communication Cables	2 x 18 AWG	2 x 18 AWG	2 x 18 AWG	2 x 18 AWG	2 x 18 AWG	2 x 18 AWG
Heat Rejected to Equipment Room (Btu/h)	2,152	2,322	2,493	2,357	2,459	2,561
<b>Heat Exchanger (Stainless Steel Plate)</b>						
Maximum Pressure Resistance (psi)	640	640	640	640	640	640
Flow at Rated Condition (GPM)	20.3	25.4	30.4	35.5	45.7	50.7
Range of Flow (GPM)	8.1 – 30.5	10.2 – 38.1	12.2 – 45.6	14.2 – 53.3	18.3 – 68.6	20.3 – 76.1
Total Heat of Rejection (Btu/h)	94,100	125,900	157,900	190,100	221,100	253,500
Total Heat of Absorption (Btu/h)	74,200	98,600	122,700	146,800	170,100	193,600
Pressure Drop (ft-wg)	3.7	4.7	6.9	4.7	8.0	9.2
Δt <sup>4</sup> (°F)	9.3	9.9	10.3	10.7	9.7	10.0
<b>Piping<sup>5</sup></b>						
Liquid Line Connection (in., OD)	3/8 Braze	3/8 Braze	1/2 Braze	1/2 Braze	1/2 Braze	1/2 Braze
Low Press Vapor Line Conn (in., OD)	7/8 Braze	7/8 Braze	7/8 Braze	1-1/8 Braze	1-1/8 Braze	1-1/8 Braze
High Press Vapor Line Conn (in., OD)	3/4 Braze	3/4 Braze	3/4 Braze	3/4 Braze	3/4 Braze	3/4 Braze
Water Inlet/Outlet Connection (in)	1-1/2 + 1-1/2 Fem	1-1/2 + 1-1/2 Fem	1-1/2 + 1-1/2 Fem	1-1/2 + 1-1/2 Fem	1-1/2 + 1-1/2 Fem	1-1/2 + 1-1/2 Fem
Condensate Drain (in)	3/4 Female	3/4 Female	3/4 Female	3/4 Female	3/4 Female	3/4 Female

<sup>1</sup>Nominal capacity is outside of AHRI Standard 1230 and based on the following conditions:

- Cooling – Indoor 80°F DB / 66°F WB  
Water Temperature Entering: 86°F
- Heating – Indoor 68°F DB  
Water Temperature Entering: 68°F

<sup>2</sup>When entering water temperature is lower than 59°F, variable water flow control kit PWFCKN000 is required.

<sup>3</sup>Sound pressure levels are tested in an anechoic chamber under ISO 3745 standard.

<sup>4</sup>Value is calculated as follows: Δt = Total Heat of Rejection/(Nominal Flow Rate x 500).

<sup>5</sup>Refer to the Refrigerant Piping section of this manual for correct line sizing. Contractor must use LG manufactured Y-Branch and Header Kits only. Designer must verify refrigerant piping design configuration using LG's computerized refrigerant piping software (LATS Multi V) to validate the pipe design.

## ARWB Series Heat Recovery Water Source Unit Specifications

Table 11: Dual-Frame 460V Heat Recovery Units.

Combination Unit Model Number	20.0 ARWB240DAS4	24.0 ARWB288DAS4	28.0 Ton ARWB336DAS4	32.0 ARWB384DAS4
Individual Component Model Numbers	ARWB096DAS4 x 1 +ARWB144DAS4 x 1	ARWB121DAS4 x 1 +ARWB168DAS4 x 1	ARWB168DAS4 x 2	ARWB192DAS4 x 2
<i>Cooling Performance</i>				
Nominal Cooling Capacity (Btu/h) <sup>1</sup>	239,400	287,700	336,000	384,000
<i>Heating Performance</i>				
Nominal Heating Capacity (Btu/h) <sup>1</sup>	270,000	324,000	378,000	432,000
<i>Operating Range (Entering Water Temperature)</i>				
Cooling (°F) <sup>2</sup>	23 – 113	23 – 113	23 – 113	23 – 113
Heating (°F)	14 – 113	14 – 113	14 – 113	14 – 113
Synchronous Operation (°F)	23 – 113	23 – 113	23 – 113	23 – 113
<i>Compressor</i>				
Inverter Quantity	HSS DC Scroll x 2	HSS DC Scroll x 2	HSS DC Scroll x 2	HSS DC Scroll x 2
Oil/Type	PVE/FVC68D	PVE/FVC68D	PVE/FVC68D	PVE/FVC68D
<i>Unit Data</i>				
Refrigerant Type	R410A	R410A	R410A	R410A
R410A Refrigerant Factory Charge (lbs)	12.8 + 6.6	12.8 + 6.6	6.6 + 6.6	6.6 + 6.6
Refrigerant Control/Location	EEV/Indoor Unit	EEV/Indoor Unit	EEV/Indoor Unit	EEV/Indoor Unit
Max. Number Indoor Units/System <sup>2</sup>	39	45	55	61
Sound Pressure dB(A) <sup>3</sup> Cooling/Heating	57/57	59/58	59/61	56/61
Net Unit Weight (lbs.)	280 + 309	280 + 309	309 + 309	309 + 309
Shipping Weight (lbs.)	302 + 331	302 + 331	331 + 331	331 + 331
Communication Cables	2 x 18 AWG	2 x 18 AWG	2 x 18 AWG	2 x 18 AWG
Heat Rejected to Equipment Room (Btu/h)	4,679	4952	4918	5122
<i>Heat Exchanger (Stainless Steel Plate)</i>				
Maximum Pressure Resistance (psi)	640	640	640	640
Flow at Rated Condition (GPM)	25.4 + 35.5	30.4 + 45.7	45.7 + 45.7	50.7 + 50.7
Range of Flow (GPM)	24.4 – 91.4	30.4 – 114.2	36.6 – 171.4	40.6 – 152.1
Total Heat of Rejection (Btu/h)	125,900 + 190,100	157,900 + 221,100	221,100 x 2	253,500 x 2
Total Heat of Absorption (Btu/h)	98,600 + 146,800	122,700 + 170,100	170,100 x 2	193,600 x 2
Pressure Drop (ft-wg)	4.7 + 4.7	6.9 + 8.0	8.0 + 8.0	9.2 + 9.2
Δt <sup>4</sup> (°F)	10.4	10.0	9.7	10.0
<i>Piping<sup>5</sup></i>				
Liquid Line Connection (in., OD)	3/8 + 1/2 Braze	1/2 + 1/2 Braze	1/2 + 1/2 Braze	1/2 + 1/2 Braze
Low Pressure Vapor Line Conn (in., OD)	7/8 + 1-1/8 Braze	7/8 + 1-1/8 Braze	1-1/8 + 1-1/8 Braze	1-1/8 + 1-1/8 Braze
High Pressure Vapor Line Conn (in., OD)	3/4 + 3/4 Braze	3/4 + 3/4 Braze	3/4 + 3/4 Braze	3/4 + 3/4 Braze
Water Inlet/Outlet Connection Size (in)	(1-1/2 + 1-1/2 Fem) x2	(1-1/2 + 1-1/2 Fem) x2	(1-1/2 + 1-1/2 Fem) x2	(1-1/2 + 1-1/2 Fem) x2
Condensate Drain (in)	3/4 Female	3/4 Female	3/4 Female	3/4 Female

<sup>1</sup>Nominal capacity is outside of AHRI Standard 1230 and based on the following conditions:

- Cooling – Indoor 80°F DB / 66°F WB  
Water Temperature Entering: 86°F
- Heating – Indoor 68°F DB  
Water Temperature Entering: 68°F

<sup>2</sup>When entering water temperature is lower than 59°F, variable water flow control kit PWFCKN000 is required.

<sup>3</sup>Sound pressure levels are tested in an anechoic chamber under ISO 3745 standard.

<sup>4</sup>Value is calculated as follows: Δt = Total Heat of Rejection/(Nominal Flow Rate x 500).

<sup>5</sup>Refer to the Refrigerant Piping section of this manual for correct line sizing. Contractor must use LG manufactured Y-Branch and Header Kits only. Designer must verify refrigerant piping design configuration using LG's computerized refrigerant piping software (LATS Multi V) to validate the pipe design.

# GENERAL DATA



## ARWB Series Heat Recovery Water Source Unit Specifications

Table 12: Triple-Frame 460V Heat Recovery Units

Combination Unit Model Number	40.0 Ton ARWB480DAS4	48.0 ARWB576DAS4
Individual Component Model Numbers	ARWB144DAS4 x 2 +ARWB192DAS4 x 1	ARWB192DAS4 x 3
<i>Cooling Performance</i>		
Nominal Cooling Capacity (Btu/h) <sup>1</sup>	472,500	571,200
<i>Heating Performance</i>		
Nominal Heating Capacity (Btu/h) <sup>1</sup>	540,000	648,000
<i>Operating Range (Entering Water Temperature)</i>		
Cooling (°F) <sup>2</sup>	23 – 113	23 – 113
Heating (°F)	14 – 113	14 – 113
Synchronous Operation (°F)	23 – 113	23 – 113
<i>Compressor</i>		
Inverter Quantity	HSS DC Scroll x 3	HSS DC Scroll x 3
Oil/Type	PVE/FVC68D	PVE/FVC68D
<i>Unit Data</i>		
Refrigerant Type	R410A	R410A
R410A Refrigerant Factory Charge (lbs)	6.6 + 6.6 + 6.6	6.6 + 6.6 + 6.6
Refrigerant Control/Location	EEV/Indoor Unit	EEV/Indoor Unit
Max. Number Indoor Units/System <sup>2</sup>	64	64
Sound Pressure dB(A) <sup>3</sup> Cooling/Heating	60/62	60/62
Net Unit Weight (lbs.)	309 + 309 + 309	309 + 309 + 309
Shipping Weight (lbs.)	331 + 331 + 331	331 + 331 + 331
Communication Cables	2 x 18 AWG	2 x 18 AWG
Heat Rejected to Equipment Room (Btu/h)	7275	7863
<i>Heat Exchanger (Stainless Steel Plate)</i>		
Maximum Pressure Resistance (psi)	640	640
Flow at Rated Condition (GPM)	35.5 + 35.5 + 50.7	50.7 + 50.7 + 50.7
Range of Flow (GPM)	48.7 – 182.6	60.8 – 228.2
Total Heat of Rejection (Btu/h)	190,100 + 190,100 + 253,500	253,500 + 253,500 + 253,500
Total Heat of Absorption (Btu/h)	146,800 + 146,800 + 193,600	193,600 + 193,600 + 193,600
Pressure Drop (ft-wg)	4.7 + 4.7 + 9.2	9.2 + 9.2 + 9.2
Δt <sup>4</sup> (°F)	10.4	10.0
<i>Piping<sup>5</sup></i>		
Liquid Line Connection (in., OD)	1/2 + 1/2 + 1/2 Braze	1/2 + 1/2 + 1/2 Braze
Low Pressure Vapor Line Conn (in., OD)	1-1/8 + 1-1/8 + 1-1/8 Braze	1-1/8 + 1-1/8 + 1-1/8 Braze
High Pressure Vapor Line Conn (in., OD)	3/4 + 3/4 + 3/4 Braze	3/4 + 3/4 + 3/4 Braze
Water Inlet/Outlet Connection Size (in)	(1-1/2 + 1-1/2 Fem) x3	(1-1/2 + 1-1/2 Fem) x3
Condensate Drain (in)	3/4 Female	3/4 Female

<sup>1</sup>Nominal capacity is outside of AHRI Standard 1230 and based on the following conditions:

- Cooling – Indoor 80°F DB / 66°F WB  
Water Temperature Entering: 86°F
- Heating – Indoor 68°F DB  
Water Temperature Entering: 68°F

<sup>2</sup>When entering water temperature is lower than 59°F, variable water flow control kit PWFCCKN000 is required.

<sup>3</sup>Sound pressure levels are tested in an anechoic chamber under ISO 3745 standard.

<sup>4</sup>Value is calculated as follows: Δt = Total Heat of Rejection/(Nominal Flow Rate x 500).

<sup>5</sup>Refer to the Refrigerant Piping section of this manual for correct line sizing. Contractor must use LG manufactured Y-Branch and Header Kits only. Designer must verify refrigerant piping design configuration using LG's computerized refrigerant piping software (LATS Multi V) to validate the pipe design.

## Heat Recovery Unit Specifications and Electrical Data

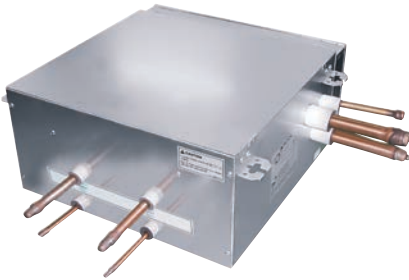

Figure 1: Two-Port Heat Recovery Unit.

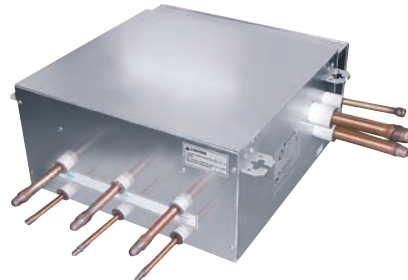

Figure 2: Three-Port Heat Recovery Unit.

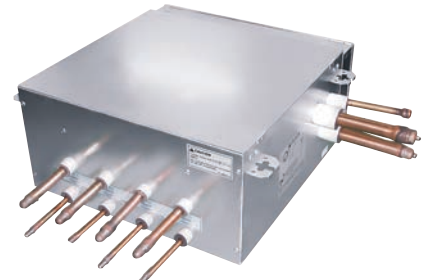

Figure 3: Four-Port Heat Recovery Unit.

**Note:**

Heat recovery units can only be used with LG heat recovery systems.

Table 13: Heat Recovery Unit Specifications.

Model		PRHR022A	PRHR032A	PRHR042A	
Number of Ports		2	3	4	
Max. Connectable No. of Indoor Units		16	24	32	
Max. Connectable No. of Indoor Units on each port		8	8	8	
Max. Port Capacity (each port) Btu/h		54,000	54,000	54,000	
Max. Unit Capacity (sum of ports) Btu/h		192,000	192,000	192,000	
Net Weight lbs.		40	45	49	
Dimensions (W x H x D) inches		31-1/2 x 8-5/8 x 24-5/16			
Casing		Galvanized steel plate			
Connecting Pipes	To Indoor Units	Liquid Pipe (inches)	3/8		
		Vapor Pipe (inches)	5/8		
	To Water Source Units	Liquid (inches)	3/8	1/2	5/8
		Low-pressure Vapor (inches)	7/8	1-1/8	1-1/8
High-pressure Vapor (inches)		3/4	7/8	7/8	
Insulation Material		Polyethylene			
Current	Minimum Circuit Amps (MCA)	0.1	0.15	0.2	
	Maximum Fuse Amps (MFA)	15			
Power Supply		1Ø, 208-230V, 60Hz			

Table 14: Heat Recovery Unit Electrical Data.

Unit Model No.	V / Hz / Phase	Input (kW)	
		Cooling	Heating
PRHR022A	208-230 / 60 / 1	0.026	0.026
PRHR032A	208-230 / 60 / 1	0.040	0.040
PRHR042A	208-230 / 60 / 1	0.040	0.040

# ELECTRICAL DATA



## ARWN Series Heat Pump Water Source Units

Table 15: 208-230V, 60Hz, 3-Phase Heat Pump Systems

Nom. Tons	HP	System Model No.	Compressor (Comp.)				MCA			MOCP		
			Comp. Qty.	Motor RLA (Ea.)			Frame 1	Frame 2	Frame 3	Frame 1	Frame 2	Frame 3
				Frame 1	Frame 2	Frame 3						
6.0	8	ARWN072BAS4	1	28.0	-	-	35.0	-	-	60	-	-
8.0	10	ARWN096BAS4	1	28.4	-	-	35.5	-	-	60	-	-
10.0	12	ARWN121BAS4	1	28.8	-	-	36.0	-	-	60	-	-
12.0	14	ARWN144BAS4	1	28.8	-	-	36.5	-	-	60	-	-
14.0	18	ARWN168BAS4	2	28.4	28.0	-	35.5	35.0	-	60	60	-
16.0	20	ARWN192BAS4	2	28.8	28.0	-	36.0	35.0	-	60	60	-
18.0	22	ARWN216BAS4	2	28.8	28.0	-	36.0	35.0	-	60	60	-
24.0	28	ARWN288BAS4	2	28.8	28.8	-	36.0	36.0	-	60	60	-
30.0	36	ARWN360BAS4	3	28.8	28.8	28.0	36.0	36.0	35.0	60	60	60
36.0	42	ARWN432BAS4	3	28.8	28.8	28.8	36.0	36.0	36.0	60	60	60

For component model nos. see the specification tables on p. 14-16.

Voltage tolerance is ±10%.

Maximum allowable voltage unbalance is 2%.

MCA = Minimum Circuit Ampacity.

Maximum Overcurrent Protection (MOCP) is calculated as follows: (Largest motor FLA x 2.25) + (Sum of other motor FLA) rounded down to the nearest standard fuse size.

Table 16: 460V, 60Hz, 3-Phase Heat Pump Systems

Nom. Tons	System Model No.	Compressor (Comp.)				MCA			MOCP			RFA		
		Comp. Qty.	Motor RLA (Ea.)			Frame 1	Frame 2	Frame 3	Frame 1	Frame 2	Frame 3	Frame 1	Frame 2	Frame 3
			Frame 1	Frame 2	Frame 3									
6.0	ARWN072DAS4	1	13.0	-	-	16.2	-	-	25	-	-	25	-	-
8.0	ARWN096DAS4	1	13.8	-	-	17.2	-	-	25	-	-	25	-	-
10.0	ARWN121DAS4	1	15.4	-	-	19.3	-	-	25	-	-	25	-	-
12.0	ARWN144DAS4	1	20.6	-	-	25.7	-	-	45	-	-	35	-	-
14.0	ARWN168DAS4	1	21.6	-	-	27.0	-	-	45	-	-	35	-	-
16.0	ARWN192DAS4	1	22.4	-	-	28.0	-	-	50	-	-	35	-	-
20.0	ARWN240DAS4	2	20.6	13.8	-	25.7	17.2	-	45	25	-	35	25	-
24.0	ARWN288DAS4	2	21.6	15.4	-	27.0	19.3	-	45	25	-	35	25	-
28.0	ARWN336DAS4	2	21.6	21.6	-	27.0	27.0	-	45	45	-	35	35	-
32.0	ARWN384DAS4	2	22.4	22.4	-	28.0	28.0	-	50	50	-	35	35	-
40.0	ARWN480DAS4	3	22.4	20.6	20.6	28.0	25.7	25.7	50	45	45	35	35	35
48.0	ARWN576DAS4	3	22.4	22.4	22.4	28.0	28.0	28.0	50	50	50	35	35	35

For component model nos. see the specification tables on p. 14-16.

Voltage tolerance is ±10%.

Maximum allowable voltage unbalance is 2%.

MCA = Minimum Circuit Ampacity.

Maximum Overcurrent Protection (MOCP) is calculated as follows: (Largest motor FLA x 2.25) + (Sum of other motor FLA) rounded down to the nearest standard fuse size.

## ARWB Series Heat Recovery Water Source Units

Table 17: 208-230V, 60Hz, 3-Phase Heat Recovery Systems.

Nom. Tons	HP	System Model No.	Compressor (Comp.)				MCA			MOCP		
			Comp. Qty.	Motor RLA (Ea.)			Frame 1	Frame 2	Frame 3	Frame 1	Frame 2	Frame 3
				Frame 1	Frame 2	Frame 3						
6.0	8	ARWB072BAS4	1	28.0	-	-	35.0	-	-	60	-	-
8.0	10	ARWB096BAS4	1	28.4	-	-	35.5	-	-	60	-	-
10.0	12	ARWB121BAS4	1	28.8	-	-	36.0	-	-	60	-	-
12.0	14	ARWB144BAS4	1	28.8	-	-	36.0	-	-	60	-	-
14.0	18	ARWB168BAS4	2	28.4	28.0	-	35.5	35.0	-	60	60	-
16.0	20	ARWB192BAS4	2	28.8	28.0	-	36.0	35.0	-	60	60	-
18.0	22	ARWB216BAS4	2	28.8	28.0	-	36.0	36.0	-	60	60	-
24.0	28	ARWB288BAS4	2	28.8	28.8	-	36.0	36.0	-	60	60	-
30.0	36	ARWB360BAS4	3	28.8	28.8	28.0	36.0	36.0	35.0	60	60	60
36.0	42	ARWB432BAS4	3	28.8	28.8	28.8	36.0	36.0	36.0	60	60	60

For component model nos. see the specification tables on p. 14-16.

Voltage tolerance is ±10%.

Maximum allowable voltage unbalance is 2%.

MCA = Minimum Circuit Ampacity.

Maximum Overcurrent Protection (MOCP) is calculated as follows: (Largest motor FLA x 2.25) + (Sum of other motor FLA) rounded down to the nearest standard fuse size.

Table 18: 460V, 60Hz, 3-Phase Heat Recovery Systems.

Nom. Tons	System Model No.	Compressor (Comp.)				MCA			MOCP			RFA		
		Comp. Qty.	Motor RLA (Ea.)			Frame 1	Frame 2	Frame 3	Frame 1	Frame 2	Frame 3	Frame 1	Frame 2	Frame 3
			Frame 1	Frame 2	Frame 3									
6.0	ARWB072DAS4	1	13.0	-	-	16.2	-	-	25	-	-	25	-	-
8.0	ARWB096DAS4	1	13.8	-	-	17.2	-	-	25	-	-	25	-	-
10.0	ARWB121DAS4	1	15.4	-	-	19.3	-	-	25	-	-	25	-	-
12.0	ARWB144DAS4	1	20.6	-	-	25.7	-	-	45	-	-	35	-	-
14.0	ARWB168DAS4	1	21.6	-	-	27.0	-	-	45	-	-	35	-	-
16.0	ARWB192DAS4	1	22.4	-	-	28.0	-	-	50	-	-	35	-	-
20.0	ARWB240DAS4	2	20.6	13.8	-	25.7	17.2	-	45	25	-	35	25	-
24.0	ARWB288DAS4	2	21.6	15.4	-	27.0	19.3	-	45	25	-	35	25	-
28.0	ARWB336DAS4	2	21.6	21.6	-	27.0	27.0	-	45	45	-	35	35	-
32.0	ARWB384DAS4	2	22.4	22.4	-	28.0	28.0	-	50	50	-	35	35	-
40.0	ARWB480DAS4	3	22.4	20.6	20.6	28.0	25.7	25.7	50	45	45	35	35	35
48.0	ARWB576DAS4	3	22.4	22.4	22.4	28.0	28.0	28.0	50	50	50	35	35	35

For component model nos. see the specification tables on p. 14-16.

Voltage tolerance is ±10%.

Maximum allowable voltage unbalance is 2%.

MCA = Minimum Circuit Ampacity.

Maximum Overcurrent Protection (MOCP) is calculated as follows: (Largest motor FLA x 2.25) + (Sum of other motor FLA) rounded down to the nearest standard fuse size.

# WATER SOURCE UNIT DIMENSIONS



Single Frame Heat Pump and Heat Recovery

X	13-1/2"
Y	9-13/16"
Z	16-1/2"
W	29-3/4"
D	19-3/4"
H	39-1/4"
L1	6-5/8"
L2	25"
L3	29-1/4"
L4	32-1/2"
L5	35-15/16"
L6	3-1/8"
L7	2-1/4"
L8	14-3/4"
M1	18-1/4"
M2	3/4"
M3	2-7/16"
M4	24-13/16"

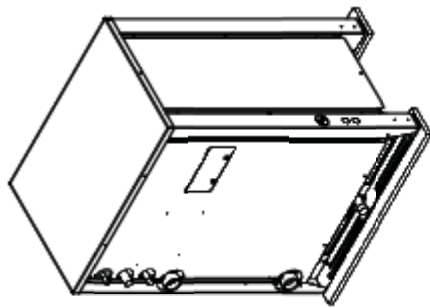

Isometric

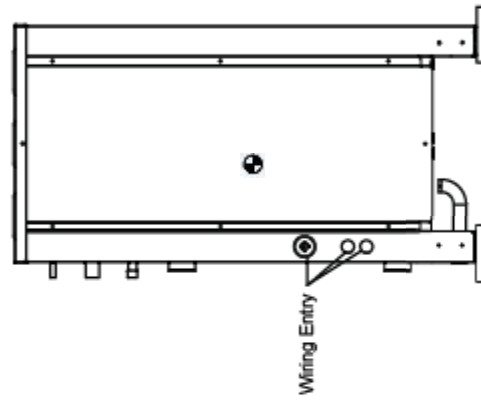

Side View

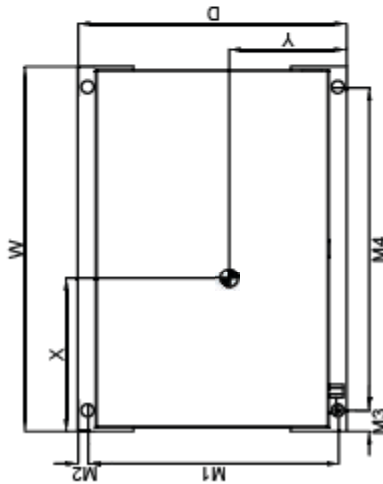

Top View

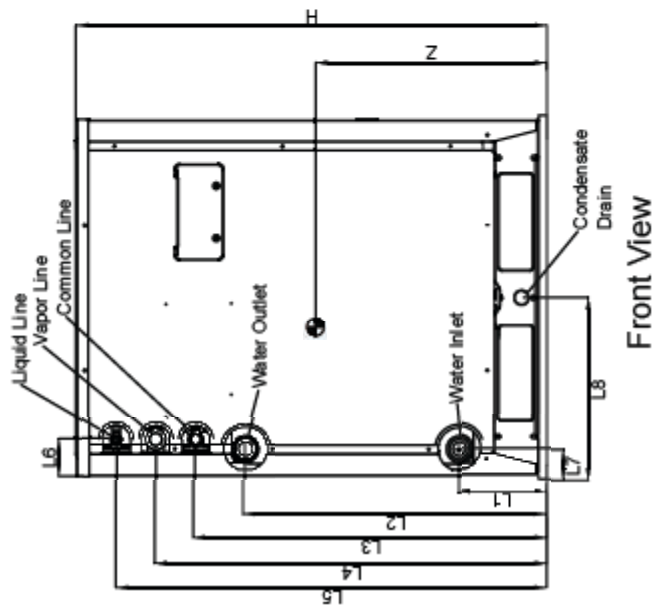

Front View



# WATER SOURCE UNIT DIMENSIONS

Dual Frame Heat Pump and Heat Recovery

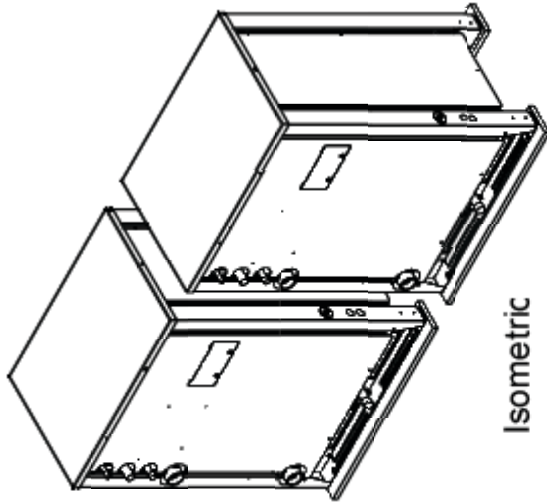

Isometric

X	13-1/2"
Y	9-13/16"
Z	16-1/2"
W	29-3/4"
D	19-3/4"
H	39-1/4"
L1	6-5/8"
L2	25"
L3	29-1/4"
L4	32-1/2"
L5	35-15/16"
L6	3-1/8"
L7	2-1/4"
L8	14-3/4"
L9	4"
M1	18-1/4"
M2	3/4"
M3	2-7/16"
M4	24-13/16"

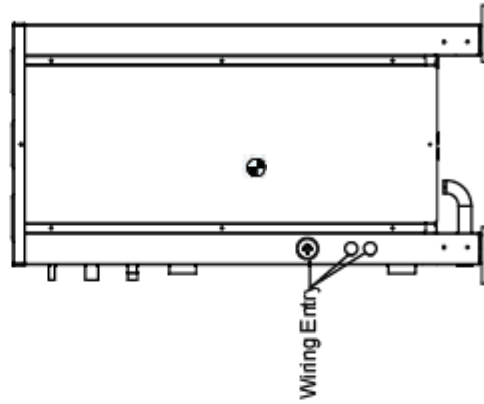

Side View

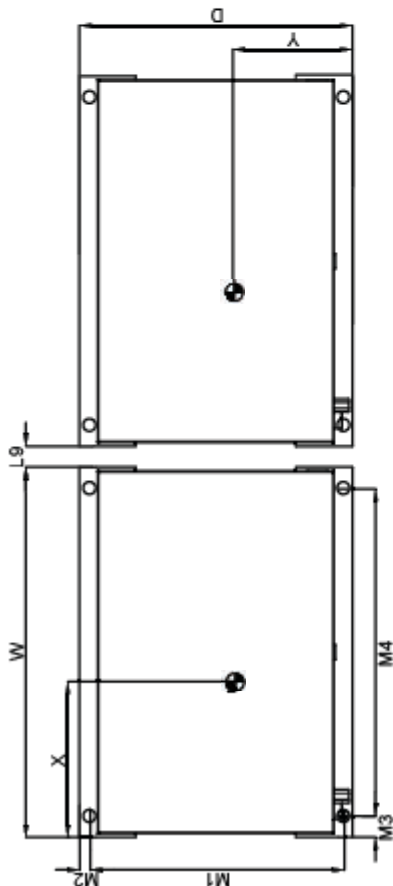

Top View

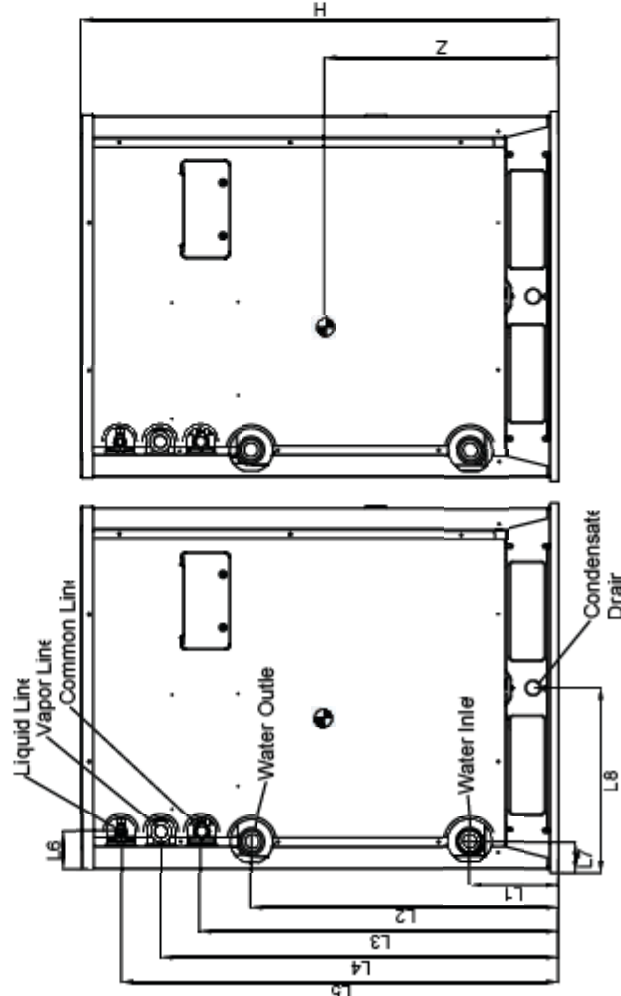

Front View

# WATER SOURCE UNIT DIMENSIONS



Triple Frame Heat Pump and Heat Recovery

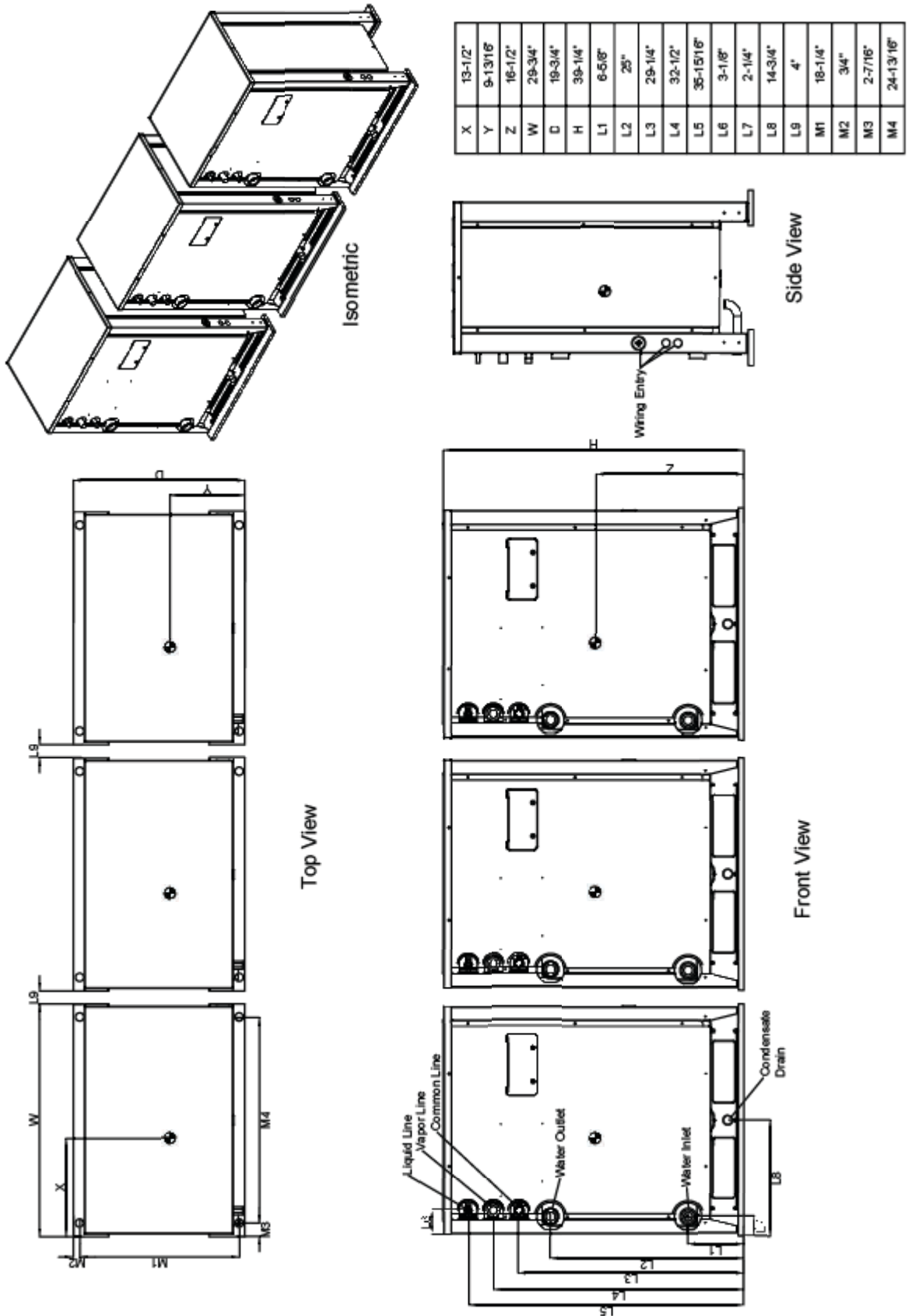

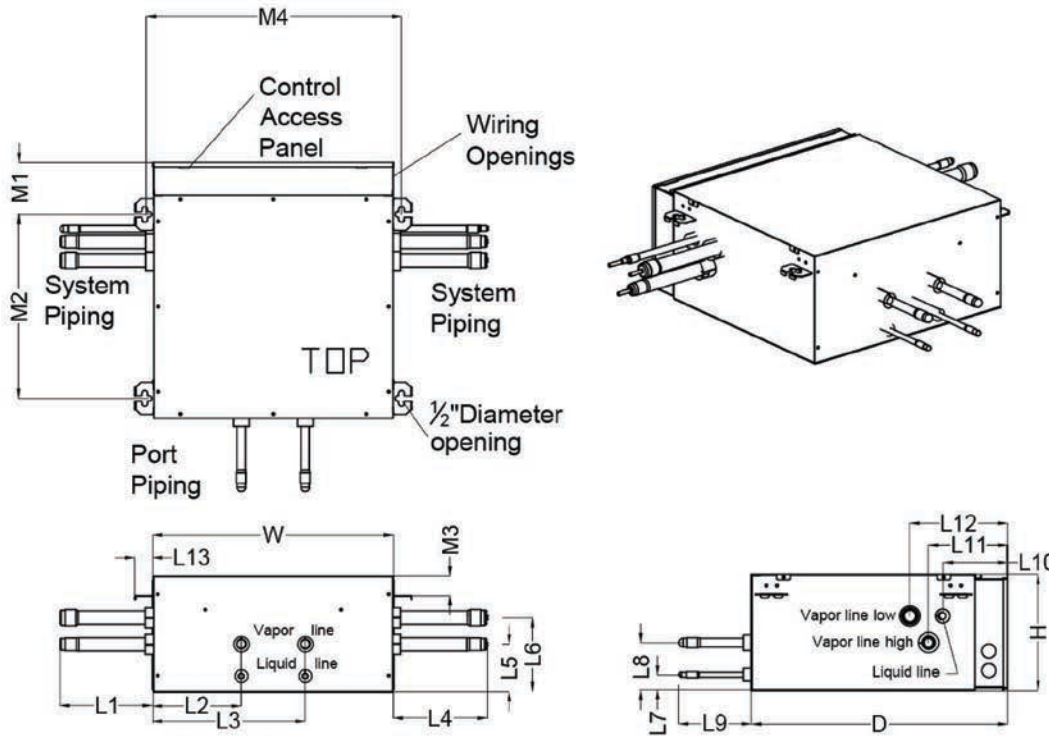

W	17-7/8"
H	8-5/8"
D	18-15/16"
L1	6-7/8"
L2	6-5/8"
L3	11-3/8"
L4	6-7/8"
L5	3-1/2"
L6	5-1/2"
L7	1-3/16"
L8	3-9/16"
L9	5-7/16"
L10	4-3/4"
L11	5-3/4"
L12	7-1/4"
L13	1-1/4"
M1	3-3/4"
M2	13-5/8"
M3	1-1/2"
M4	18-15/16"

Product Data

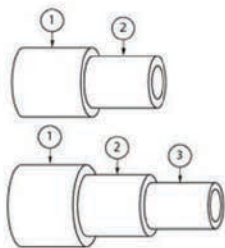

Reducer Dimensions (in)		1	2	3	Quantity
Indoor Unit	Liquid Line	3/8 OD	1/4 OD	-	2
	Vapor Line	5/8 OD	1/2 OD	-	2
HR Unit	Liquid Line	3/8 OD	1/4 OD	-	2
	Vapor Line Low	5/8 OD	1/2 OD	-	2
		7/8 OD	3/4 OD	5/8 OD	2
	Vapor Line High	1/2 OD	3/8 OD	-	2
3/4 OD		5/8 OD	1/2 OD	2	

# HEAT RECOVERY UNIT DIMENSIONS



PRHR032A

MULTI V Water IV System Installation Manual

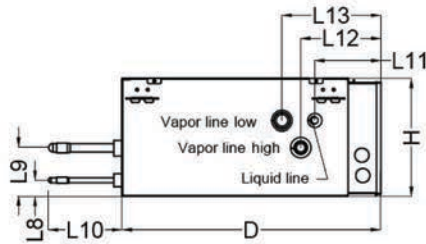
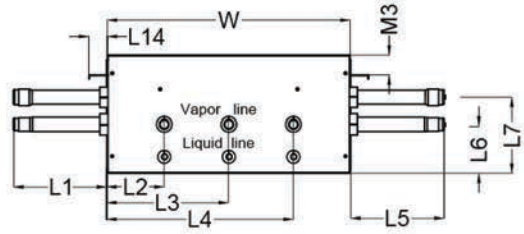
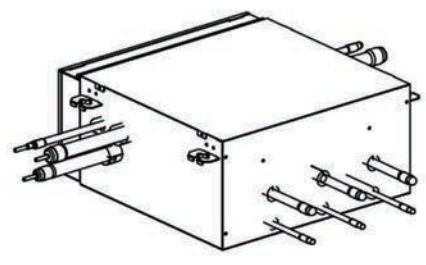
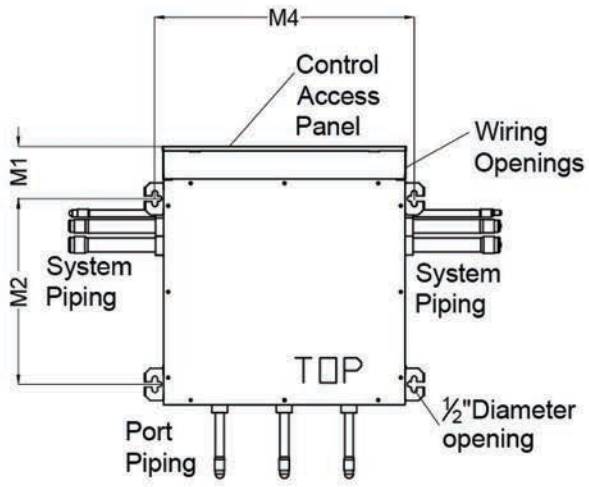

W	17-7/8"
H	8-5/8"
D	18-15/16"
L1	6-7/8"
L2	4-1/4"
L3	9"
L4	13-3/4"
L5	6-7/8"
L6	3-1/2"
L7	5-1/2"
L8	1-3/16"
L9	3-9/16"
L10	5-7/16"
L11	4-3/4"
L12	5-3/4"
L13	7-1/4"
L14	1-1/4"
M1	3-3/4"
M2	13-5/8"
M3	1-1/2"
M4	18-15/16"

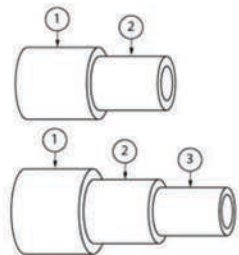

Reducer Dimensions (in)					
		1	2	3	Quantity
Indoor Unit	Liquid Line	3/8 OD	1/4 OD	-	3
	Vapor Line	5/8 OD	1/2 OD	-	3
HR Unit	Liquid Line	1/2 OD	3/8 OD	-	2
	Vapor Line Low	3/4 OD	5/8 OD	-	2
		1-1/8 OD	7/8 OD	3/4 OD	2
	Vapor Line High	5/8 OD	1/2 OD	-	2
7/8 OD		3/4 OD	5/8 OD	2	



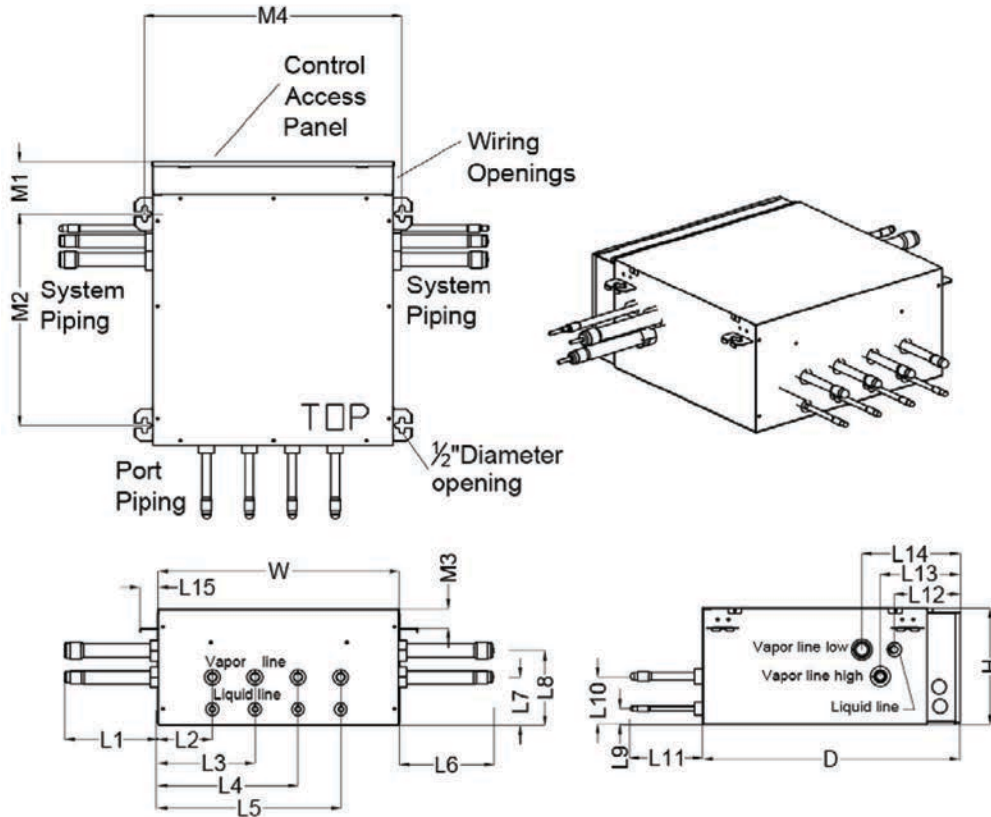

W	17-7/8"
H	8-5/8"
D	18-15/16"
L1	6-7/8"
L2	4-1/4"
L3	7-1/2"
L4	10-1/2"
L5	13-3/4"
L6	6-7/8"
L7	3-1/2"
L8	5-1/2"
L9	1-3/16"
L10	3-9/16"
L11	5-7/16"
L12	4-3/4"
L13	5-3/4"
L14	7-1/4"
L15	1-1/4"
M1	3-3/4"
M2	13-5/8"
M3	1-1/2"
M4	18-15/16"

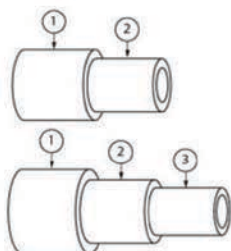

Reducer Dimensions (in)					
		1	2	3	Quantity
Indoor Unit	Liquid Line	3/8 OD	1/4 OD	-	4
	Vapor Line	5/8 OD	1/2 OD	-	4
HR Unit	Liquid Line	1/2 OD	3/8 OD	-	2
	Vapor Line Low	3/4 OD	5/8 OD	-	2
		1-1/8 OD	7/8 OD	3/4 OD	2
	Vapor Line High	5/8 OD	1/2 OD	-	2
7/8 OD		3/4 OD	5/8 OD	2	

# REFRIGERANT FLOW DIAGRAMS

## ARWN Heat Pump Systems

### Cooling Operation

208–230V 6/8/10/12 Ton; 460V 6/8/10/12/14/16 Ton

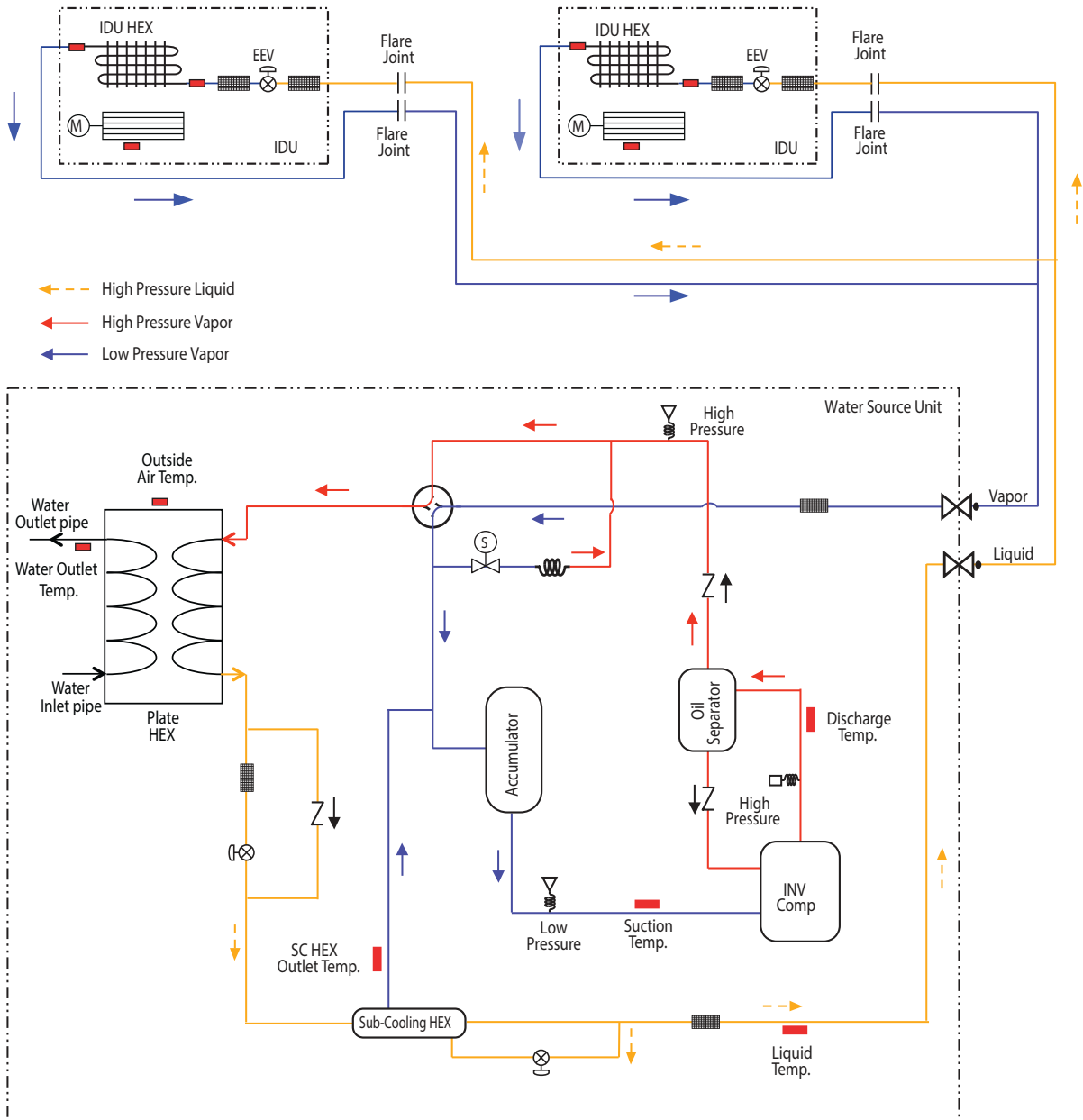

Remarks	Pressure Sensor	EEV	Service Valve	4-Way Valve	Temperature Sensor
	Pressure Switch	Strainer	Check Valve	Solenoid Valve	

### Heating Operation

208–230V 6/8/10/12 Ton; 460V 6/8/10/12/14/16 Ton

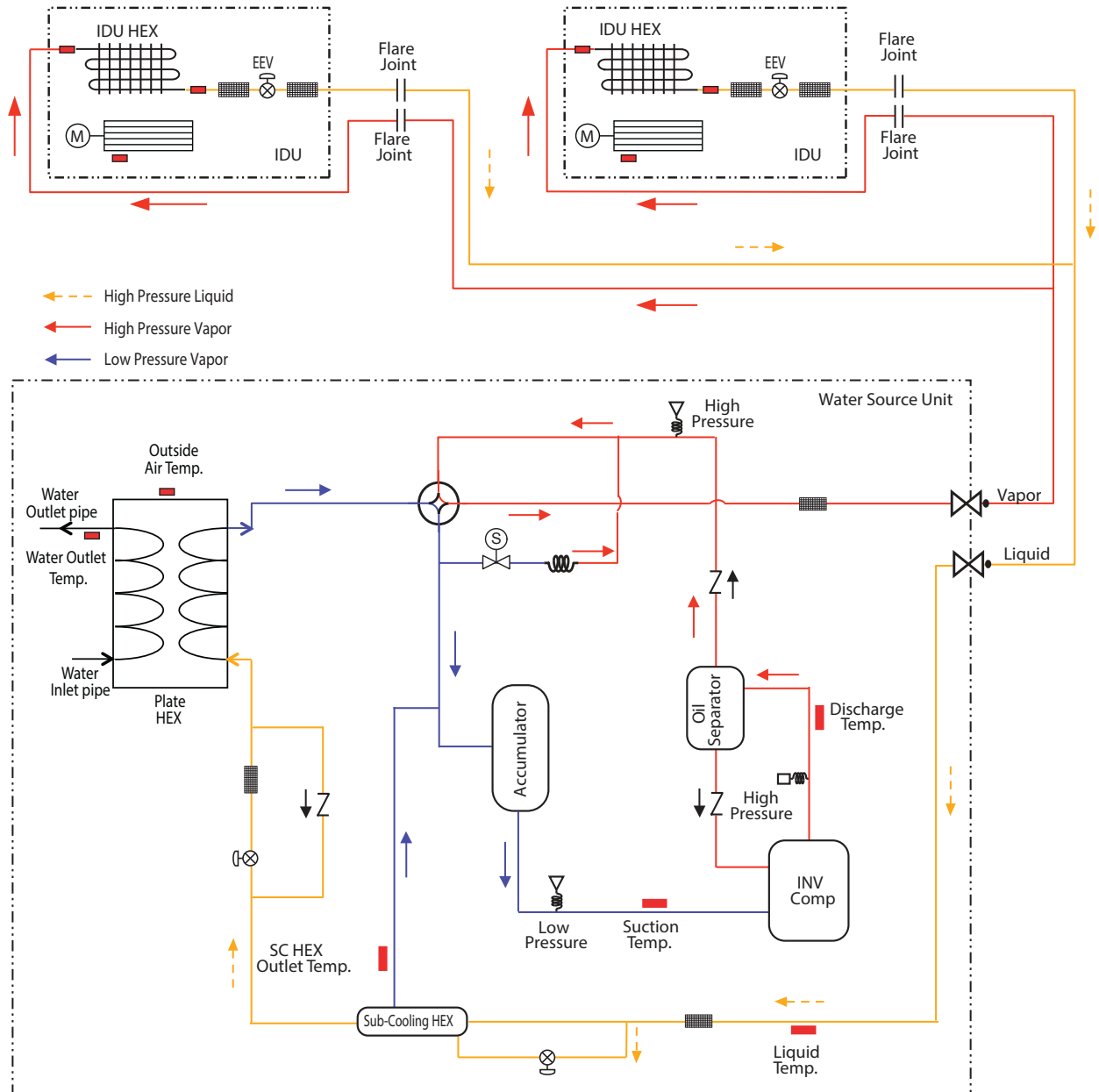

Remarks	Pressure Sensor	EEV	Service Valve	4-Way Valve	Temperature Sensor
	Pressure Switch	Strainer	Check Valve	Solenoid Valve	

Product Data

# REFRIGERANT FLOW DIAGRAMS



## ARWB Heat Recovery Systems

### Cooling Operation

208–230V 6/8/10/12 Ton; 460V 6/8/10/12/14/16 Ton

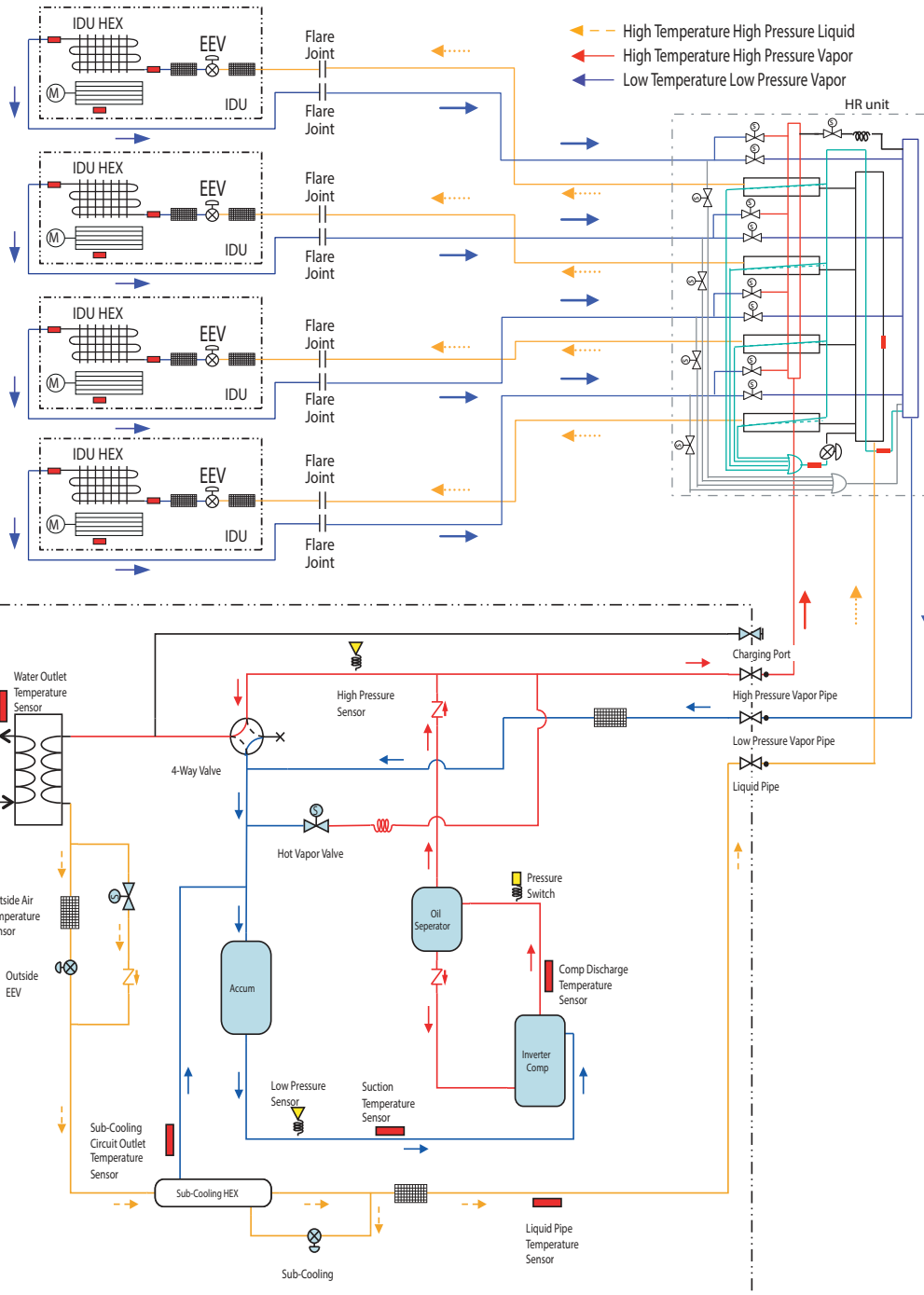

Remarks	Check Valve	EEV	Solenoid Valve	Pressure Sensor	Pressure Switch
	Strainer	Temperature Sensor	SVC Valve		





### Heating Operation

208–230V 6/8/10/12 Ton; 460V 6/8/10/12/14/16 Ton

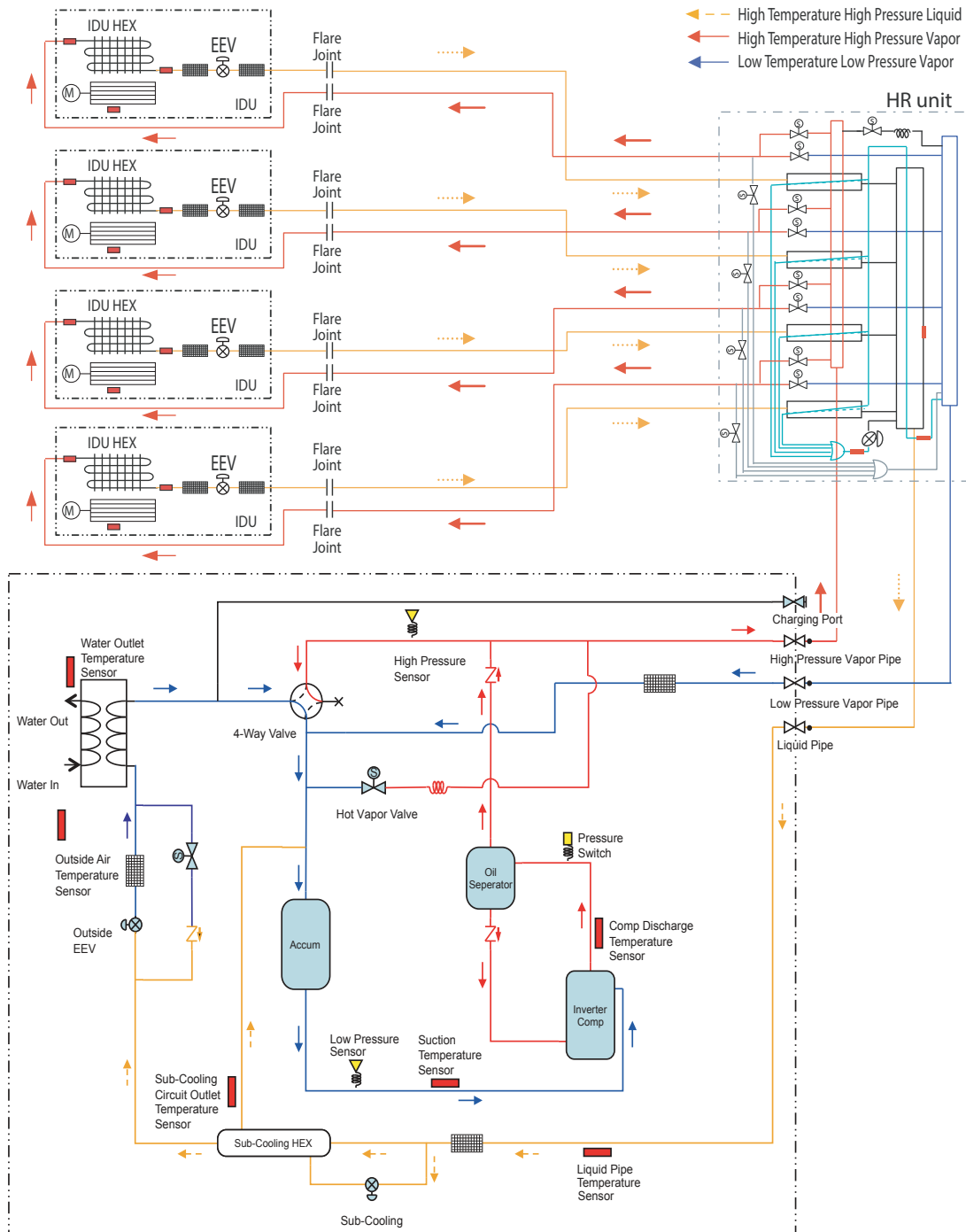

Product Data

Remarks	Check Valve	EEV	Solenoid Valve	Pressure Sensor	Pressure Switch
	Strainer	Temperature Sensor	SVC Valve		

# REFRIGERANT FLOW DIAGRAMS



## ARWB Heat Recovery Systems

### Simultaneous Operation Mode 1 (Cooling Based Operation)

208–230V 6/8/10/12 Ton; 460V 6/8/10/12/14/16 Ton

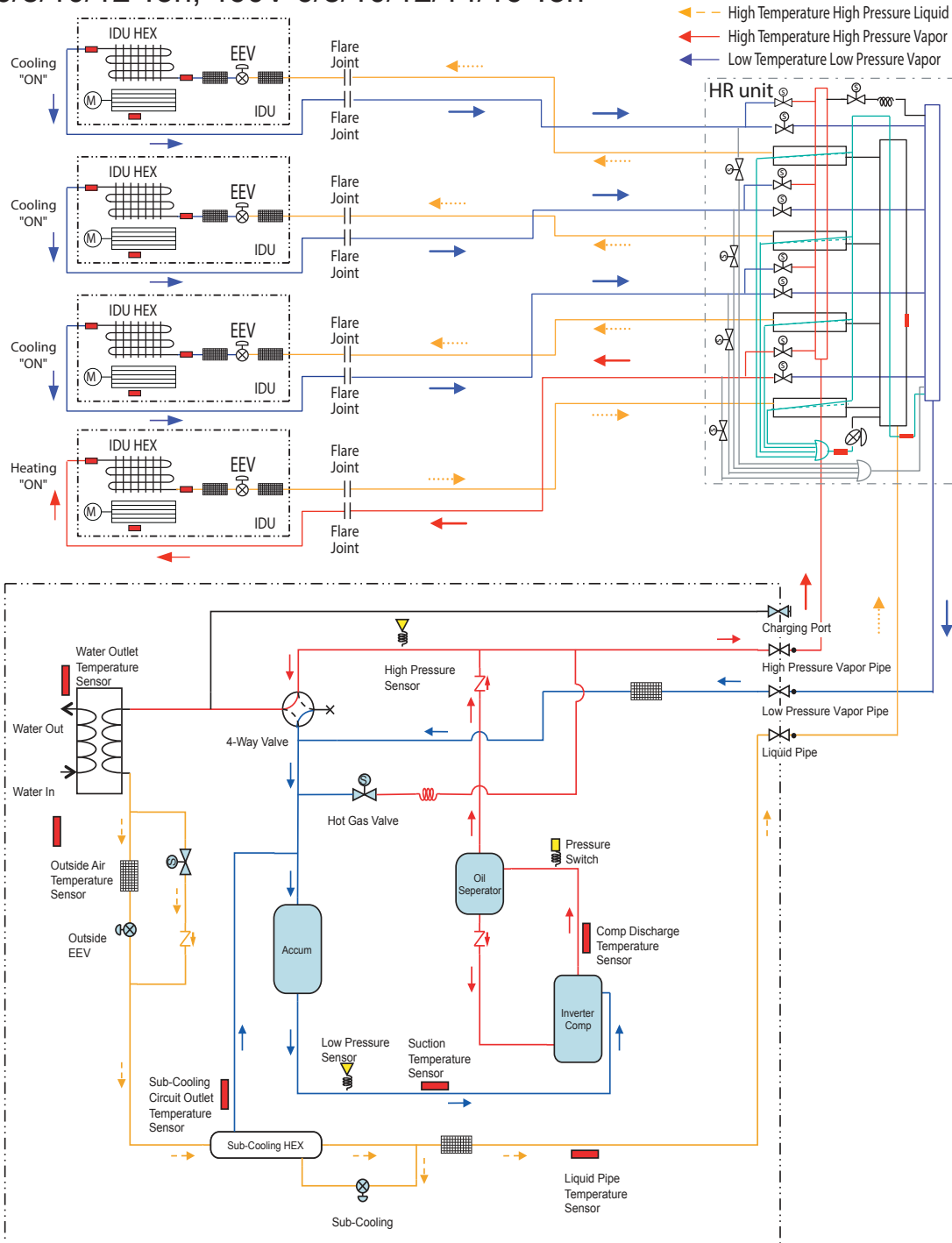

Remarks	Check Valve	EEV	Solenoid Valve	Pressure Sensor	Pressure Switch
	Strainer	Temperature Sensor	SVC Valve		



### Simultaneous Operation Mode 2 (Heating Based Operation)

208–230V 6/8/10/12 Ton; 460V 6/8/10/12/14/16 Ton

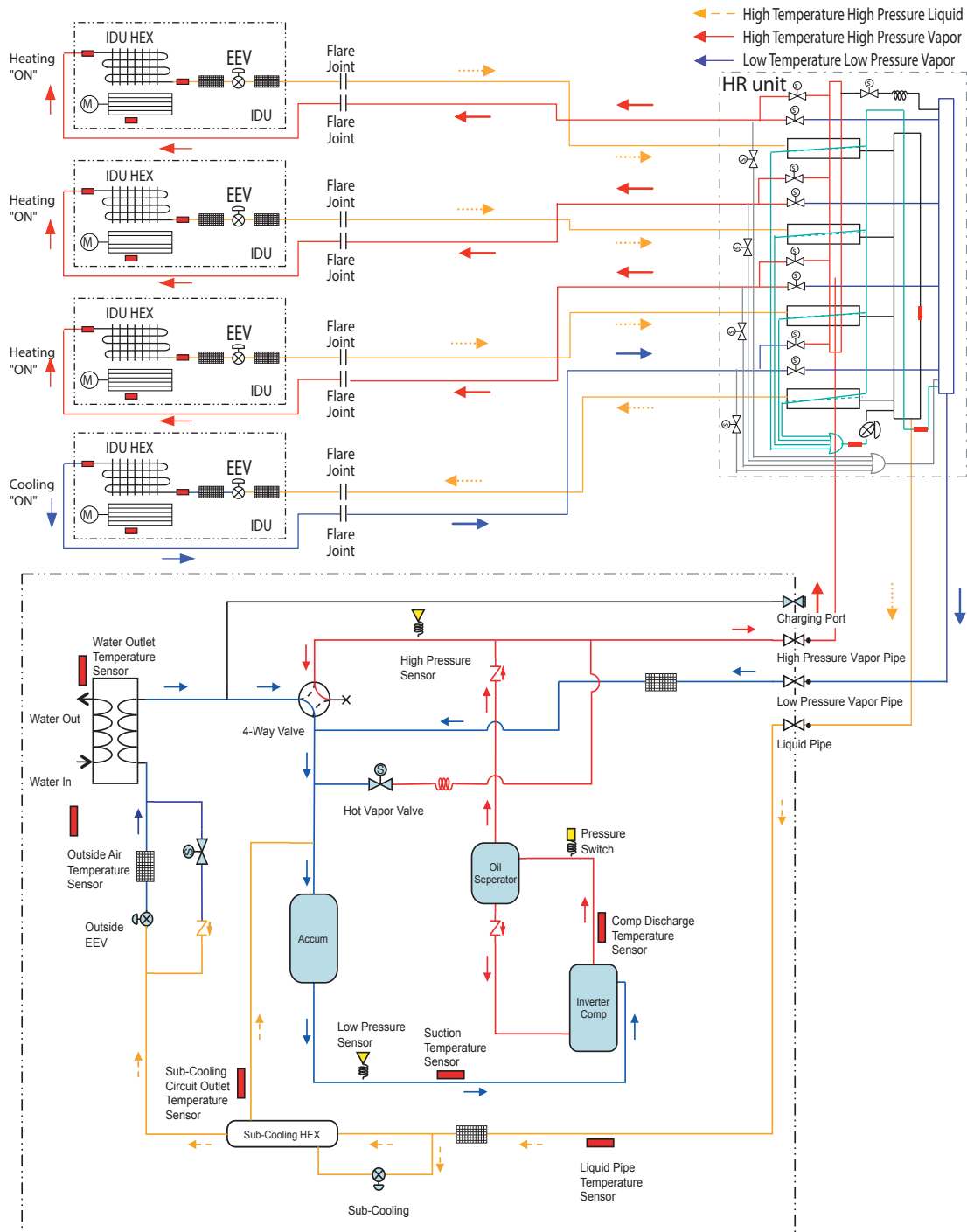

Product Data

Remarks	Check Valve	EEV	Solenoid Valve	Pressure Sensor	Pressure Switch
	Strainer	Temperature Sensor	SVC Valve		

# REFRIGERANT FLOW DIAGRAMS



## PRHR022A, PRHR032A, PRHR042A Heat Recovery Units

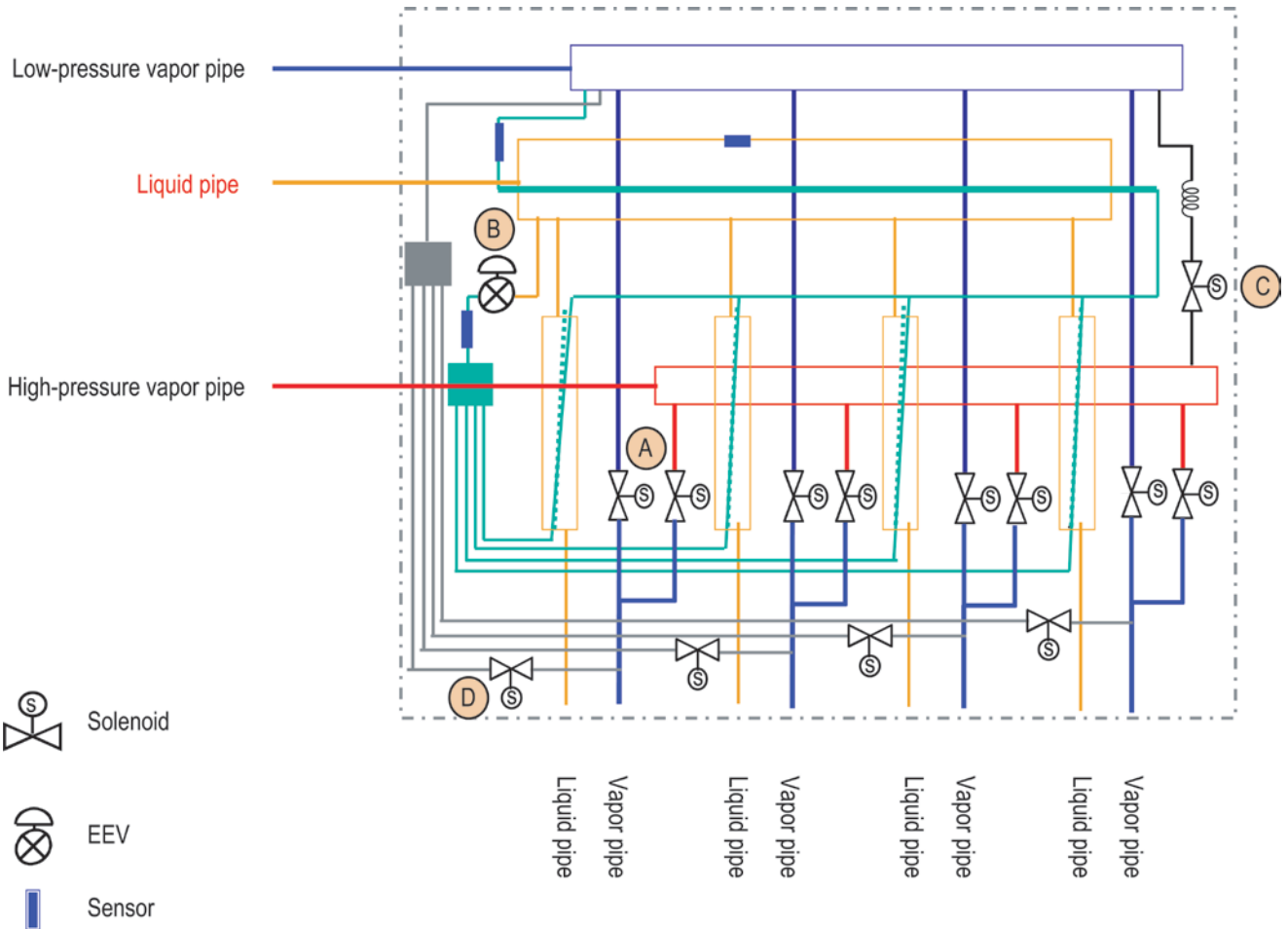

- A: Switch operation between cooling and heating.
- A: Switch operation between cooling and heating.
- B: Decreases noise following subcooling operation between inlet of one indoor unit and outlet of another indoor unit during simultaneous operation.
- C: Prevents liquid from entering high-pressure vapor valve and heat recovery unit during cooling mode.
- D: Controls pressure between the high and low pressure vapor pipes during simultaneous operation.

**Water Source Unit Y-branch Kits for Heat Pump Systems**

- LG water source unit Y-branch fittings must be used with LG systems and be properly installed following the instructions in the applicable LG manual. Field-supplied branch fittings are not permitted.
- Kit components must be kept free of debris and dry before installation.
- All Y-branch kits include a clam shell, peel-and-stick insulation jacket.

Figure 4: Y-branch Connectors (See Table 19).

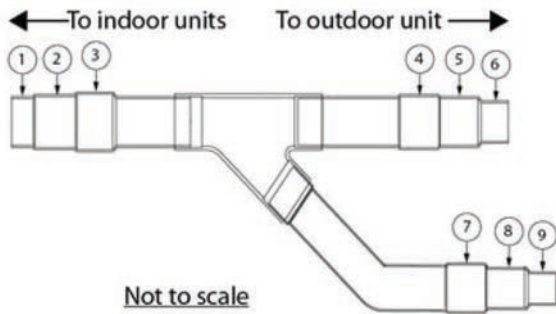

Table 19: Y-branch Connection Diameters (inches, ID).

Y-branch Kit	Y-branch Type	Port Identifier								
		1	2	3	4	5	6	7	8	9
ARCNN21	Liquid AJR67613702	—	3/4	5/8	1/2	5/8	3/8	1/2	5/8	—
	Vapor AJR72963604	1-1/8	1-1/4	1-3/8	7/8	1-1/8	—	1-1/8	—	—
ARCNN31	Liquid AJR67613704	—	7/8	3/4	3/4	—	—	5/8	1/2	—
	Vapor AJR54072908	1-1/2	1-5/8	1-3/8	1-3/8	—	—	1-1/8	—	—

Figure 5: Y-branch dimensions (See Table 20).

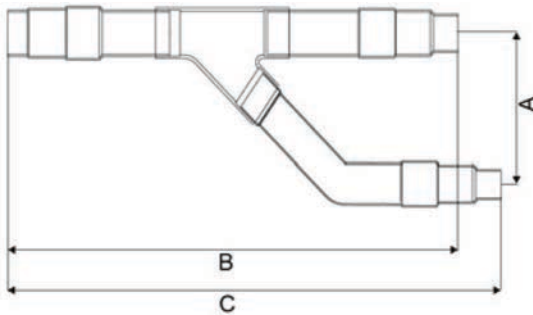

Table 20: Y-branch Dimensions (inches).

Y-branch Kit	Y-branch Type	Dimension		
		A	B	C
ARCNN21	Liquid AJR67613702	3-1/4	12-3/8	13-1/16
	Vapor AJR72963604	4-3/8	16-1/16	16-3/8
ARCNN31	Liquid AJR67613704	3-1/4	11-1/16	13-1/8
	Vapor AJR54072908	4-3/8	13-7/8	16

Figure 6: Reducer Components (See Table 21).

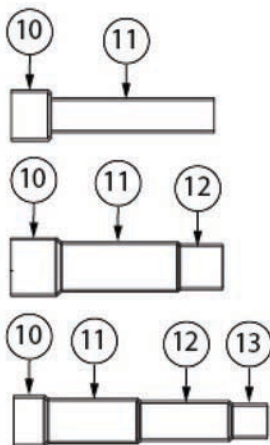

Table 21: Y-branch Reducer Diameters (inches).

Y-branch Kit	Qty/Kit	Reducer Type	Reducer Diameters (in)				
			10	11	12	13	Length
ARCNN21	4	Liquid	7/8 ID	3/8 OD	—	—	2-3/4
			5/8 OD	—	1/2 ID	3/8 ID	4-3/8
		Vapor	1-5/8 ID	1-1/2 ID	—	1-3/8 OD	5-1/8
			1-1/8 OD	—	7/8 ID	3/4 ID	4-3/4
ARCNN31	4	Liquid	3/4 ID	—	5/8 ID	1/2 ID	4-3/8
			1/2 OD	—	3/8 ID	1/4 ID	4-3/8
		Vapor	1-5/8 ID	—	1-3/8 OD	—	4-7/8
			1-1/8 OD	—	7/8 ID	3/4 ID	4-3/4

Table 22: Fitting Properties.

Material	Copper
Design Pressure	550 psig

Table 23: Insulation Jacket Properties.

Material	Polyolefin Foam
UL94 Flame Classification	HF-1
Density	1.84 lbs./ft. <sup>3</sup>
Thermal Conductivity	0.0208 Btu/h/ft. °F
Thickness	1/2 inch

# CUT SHEETS



## Indoor Unit Y-branch Kits for Heat Pump Systems

LG indoor unit Y-branch fittings must be used with LG systems and be properly installed following the instructions in the applicable LG manual. Field-supplied branch fittings are not permitted. Kit components must be kept free of debris and dry before installation. All Y-branch kits include a clam shell, peel-and-stick insulation jacket.

Table 24: Nominal Capacity Range (Btu/h).

Model	Fitting Capacity
ARBLN01621	≤72,000 connected capacity
ARBLN03321	≤144,000 connected capacity
ARBLN07121	≤336,000 connected capacity
ARBLN14521	≤432,000 connected capacity

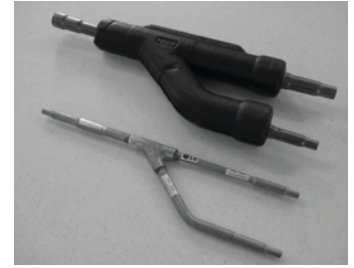

Table 25: Insulation Jacket Properties.

Material	Polyolefin Foam
UL94 Flame Classification	HF-1
Density	1.84 lbs./ft. <sup>3</sup>
Thermal Conductivity	0.0208 Btu/h/ft. <sup>2</sup> °F
Thickness	1/2 inch

**Note:**

- Design pressure is 550 psig.
- All dimensions in inches.
- Length tolerance ±1/4 inch.
- Images are not to scale.

Unit: Inch

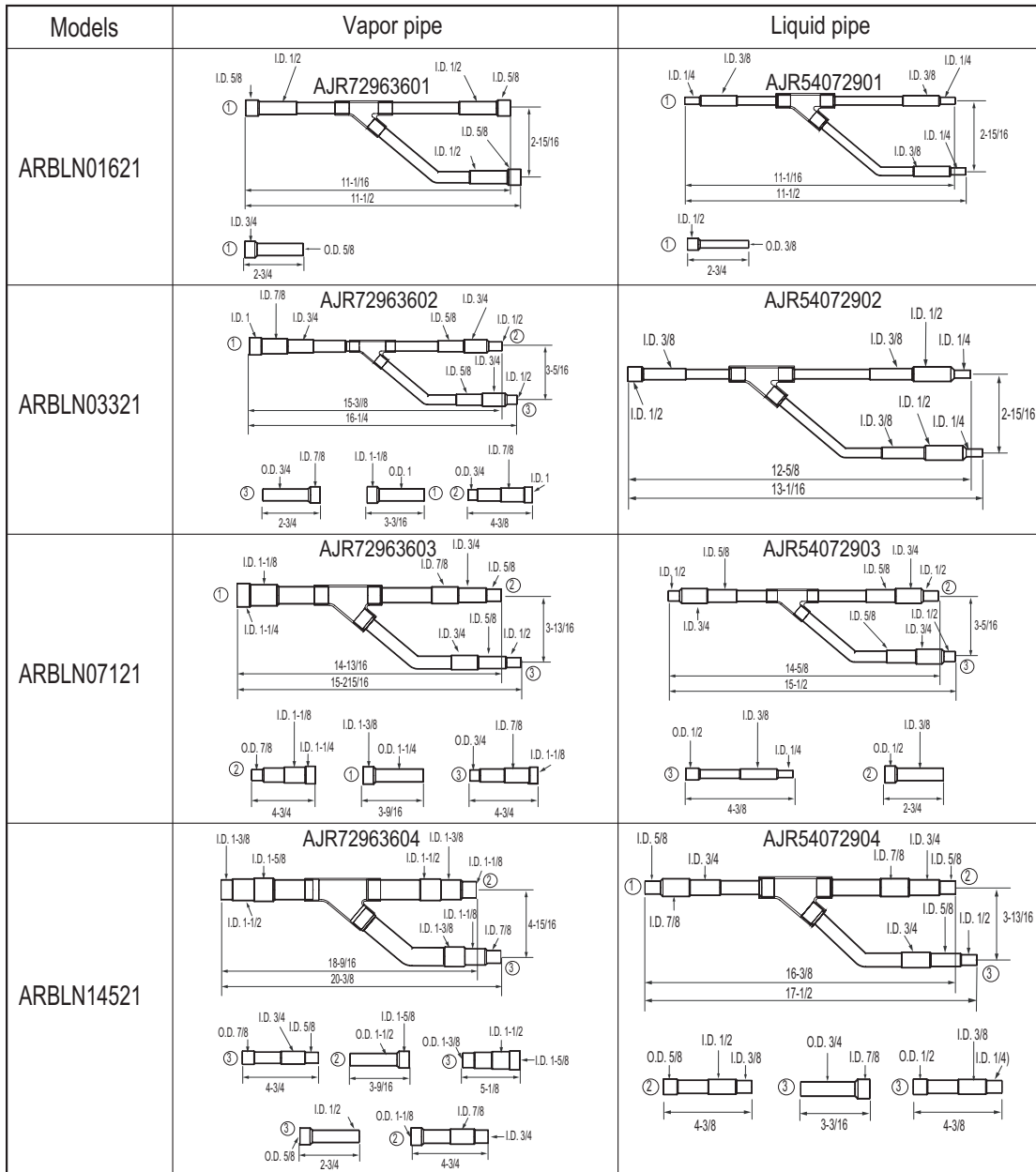

MULTI V Water IV System Installation Manual



Water Source Unit Y-branch Kits for Heat Recovery Systems

LG water source unit Y-branch fittings must be used with LG systems and be properly installed following the instructions in the applicable LG manual. Field-supplied branch fittings are not permitted. Kit components must be kept dry and free of debris before installation. All Y-branch kits include a clam shell, peel-and-stick insulation jacket.

Figure 7: Y-branch Connectors (See Table 26).

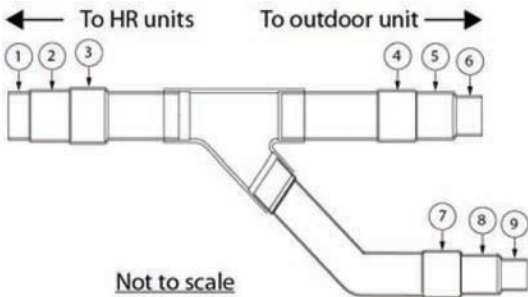

Figure 8: Y-branch Dimensions (See Table 27).

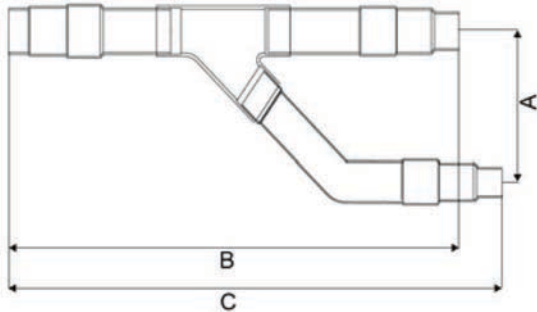

Figure 9: Reducer Components (See Table 28).

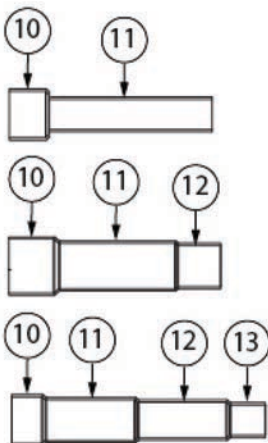

Table 29: Fitting Properties.

Material	Copper
Design Pressure	550 psig

Table 26: Y-branch Connection Diameters (inches, ID)

Y-branch Kit	Y-branch Type	Port Identifier								
		1	2	3	4	5	6	7	8	9
ARCNB21	Liquid AJR67613702	—	3/4	5/8	1/2	5/8	3/8	1/2	5/8	—
	Vapor Line Low AJR67613701	1-1/8	1-1/4	1-3/8	7/8	1-1/8	—	1-1/8	—	—
	Vapor Line High AJR72963604	1-1/8	1-3/8	1-1/4	1-1/8	1-1/4	1	1-1/8	1-1/4	1
ARCNB31	Liquid AJR67613704	—	7/8	3/4	3/4	—	—	5/8	1/2	—
	Vapor Line Low AJR67613703	1-1/2	1-5/8	1-3/8	1-3/8	—	—	1-1/8	—	—
	Vapor Line High AJR72963604	1-3/8	1-1/2	1-5/8	1-1/2	1-3/8	1-1/8	1-3/8	1-1/8	7/8

Table 27: Y-branch Dimensions (inches)

Y-branch Kit	Y-branch Type	A	B	C
ARCNB21	Liquid AJR67613702	3-1/4	12-3/8	13-1/16
	Vapor Line Low AJR67613701	4-3/8	16-1/16	16-3/8
	Vapor Line High AJR72963604	4-3/8	17-7/8	19-5/16
ARCNB31	Liquid AJR67613704	3-1/4	11-1/16	13-1/8
	Vapor Line Low AJR67613703	4-3/8	13-7/8	16
	Vapor Line High AJR72963604	4-15/16	18-9/16	20-3/8

Table 28: Y-branch Reducer Diameters (inches).

Y-branch Kit	Qty/Kit	Reducer Type	Reducer Diameters (inches)				
			10	11	12	13	Length
ARCNB21	7	Liquid	7/8 ID	3/4 OD	—	—	2-3/4
			5/8 OD	—	1/2 ID	3/8 ID	4-3/8
		Vapor Line Low	1-5/8 ID	1-1/2 ID	—	1-3/8 OD	5-1/8
			1-1/8 OD	—	7/8 ID	3/4 ID	4-3/4
		Vapor Line High	1 OD	7/8 ID	—	—	3-1/4
			1 OD	—	7/8 ID	3/4 ID	4-3/4
3/4 OD	—	5/8 OD	1/2 ID	4-3/8			
ARCNB31	6	Liquid	3/4 OD	—	5/8 ID	1/2 ID	4-3/8
			1/2 OD	—	3/8 ID	1/4 ID	4-3/8
		Vapor Line Low	1-5/8 ID	—	1-3/8 OD	—	4-7/8
			1-1/8 OD	—	7/8 ID	3/4 ID	4-3/4
		Vapor Line High	7/8 OD	—	3/4 ID	5/8 ID	4-3/4
			1-1/8 OD	—	7/8 ID	3/4 ID	4-3/4

Table 30: Insulation Jacket Properties.

Material	Polyolefin Foam
UL94 Flame Classification	HF-1
Density	1.84 lbs./ft. <sup>3</sup>
Thermal Conductivity	0.0208 Btu/h/ft. °F
Thickness	1/2 inch

# CUT SHEETS



## Indoor Unit Y-branch Kits for Heat Recovery Systems

- LG indoor unit Y-branch fittings must be used with LG systems and be properly installed following the instructions in the applicable LG manual. Field-supplied branch fittings are not permitted.
- Kit components must be kept free of debris and dry before installation.
- All Y-branch Kits include a clam shell, peel-and-stick insulation jacket.

Table 31: Nominal Capacity Range (Btu/h).

Model	Fitting Capacity
ARBLB01621	≤72,000 connected capacity
ARBLB03321	≤144,000 connected capacity
ARBLB07121	≤336,000 connected capacity
ARBLB14521	≤432,000 connected capacity

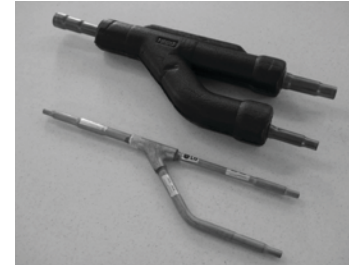

Table 32: Insulation Jacket Properties.

Material	Polyolefin Foam
UL94 Flame Classification	HF-1
Density	1.84 lbs./ft. <sup>3</sup>
Thermal Conductivity	0.0208 Btu/h/ft. °F
Thickness	1/2 inch

**Note:**

- Design pressure is 550 psig.
- All dimensions in inches.
- Length tolerance ±1/4 inch.
- Images are not to scale.

Unit: Inch

Models	Low-Pressure Vapor Pipe	Liquid pipe	High-Pressure Vapor Pipe
ARBLB01621	<p>AJR54072905</p>	<p>AJR54072901</p>	<p>AJR72963601</p>
ARBLB03321	<p>AJR54072906</p>	<p>AJR54072902</p>	<p>AJR72963602</p>
ARBLB07121	<p>AJR54072907</p>	<p>AJR54072903</p>	<p>AJR72963603</p>
ARBLB14521	<p>AJR54072908</p>	<p>AJR54072904</p>	<p>AJR72963604</p>





- LG Headers serve as central connections for multiple runout pipe segments terminating at indoor units.
- Headers must be used with LG systems and be properly installed following the instructions in the applicable LG manual. Field-supplied headers are not permitted.
- Kit components must be kept dry and free of debris before installation.
- All Header Kits include:
  - Insulation jacket (one each for vapor and liquid pipes)
  - Plugging tubes / Insulation for plugging tubes (see Table 34).

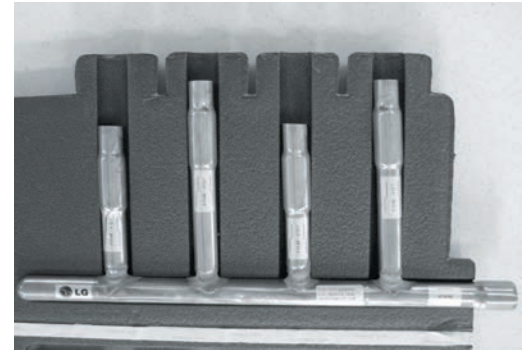

Table 33: Nominal Capacity Range.

Model	Fitting Capacity	Port Capacity
ARBL054 (4 branch)	≤72,000 connected capacity	≤54,300 per port
ARBL057 (7 branch)	≤75,100 connected capacity	≤54,300 per port
ARBL1010 (10 branch)	≤172,200 connected capacity	≤76,300 per port
ARBL104 (4 branch)	≤305,200 connected capacity	≤76,300 per port
ARBL107 (7 branch)	≤534,000 connected capacity	<76,300 per port
ARBL2010 (10 branch)	≤560,000 connected capacity	≤76,300 per port

Table 34: Plugging Tubes and Plugging Tube Insulation Amounts.

Header Kits	Plugging Tubes (in OD)			Insulation for Plugging Tubes
	1/4	1/2	5/8	
ARBL054 (4 port)	—	—	—	—
ARBL057 (7 port)	2	2	—	4
ARBL1010 (10 port)	2	2	2	6
ARBL104 (4 port)	—	—	—	—
ARBL107 (7 port)	2	2	2	6
ARBL2010 (10 port)	2	2	2	6

Table 35: Insulation Jacket Properties.

Material	Polyolefin Foam
UL94 Flame Classification	HF-1
Density	1.84 lbs./ft. <sup>3</sup>
Thermal Conductivity	.0208 Btu/h/ft. °F
Thickness	1/2 inch

Table 36: Fitting Properties.

Material	Copper
Design Pressure	550 psig

# CUT SHEETS

Header Kits, continued.



Unit: Inch

Models	Vapor pipe	Liquid pipe
4 branch ARBL054		
7 branch ARBL057		
4 branch ARBL104		
7 branch ARBL107		
10 branch ARBL1010		
10 branch ARBL2010		

MULTI V Water IV System Installation Manual



---

---

### Selecting the Best Location

The water source unit must be installed indoors in a mechanical room. The mechanical room must be designed such that equipment vibration or noise does not affect surrounding rooms, and is properly ventilated or conditioned to maintain an acceptable ambient temperature range between 32°F and 104°F. The water source unit will reject heat to the mechanical room. Refer to the General Data tables on page 9 to page 20 for the amount of heat rejected to the equipment room.

- The water source unit should be strategically located in the building to minimize refrigerant piping materials, labor, and refrigerant. The refrigerant pipe system must be designed within the piping limitations described in the Multi V Water IV Engineering Manual.
- The underlying structure or foundation must be designed per local codes and support the weight of the unit. Units can be stacked above each other as long as each water source unit is independently supported. Minimum clearances must be maintained either per recommendations shown in Figure 11 through Figure 14 or local codes, whichever is greater. Include enough space in the installation area for service access (refer to the installation space requirements).
- The mechanical room floor should be waterproof. Each water source unit requires a condensate drain to be piped to the nearest floor drain. Periodic flushing of the water heat exchanger is required, and a floor drain installed near the equipment will help facilitate this maintenance.
- The water-source unit should be installed with a closed-loop water system. If an open-loop system is used, it is recommended that an intermediate heat exchanger be installed.
- When piping, towers, or other system components that contain water are exposed to ambient air temperatures below 32°F, an anti-freeze solution must be used. Frozen water will damage the plate heat exchanger. A typical antifreeze solution consists of a proper mixture of ethylene glycol, propylene glycol, or methanol mixed with water. The designer should also consider the use of a supplemental boiler/heater to maintain minimum temperatures.

#### Note:

*Avoid exposing the water source unit to oil, steam, combustible gases, acidic solutions or sprays, carbon fiber, sulfur, or other corrosive gases. Avoid exposure to electromagnetic waves from EMF radiating machinery such as generators, MRI equipment, or other equipment that emits electromagnetic energy. The control system may be affected by electromagnetic energy, which may result in abnormal system operation. Also, the inverter components in the water source units may generate electromagnetic noise, therefore, ensure the water-source unit is placed at an acceptable distance from computer, audio, and other sensitive electronic equipment. Route power wiring and communications cables in separate conduits.*

# INSTALLATION

## Transporting/Lifting the Water Source Unit

### Transporting / Lifting

- When lifting a unit, use lifting straps placed around the unit as shown in Figure 10.
- Always lift a unit using properly sized lifting straps rated to carry the unit weight. Table 37 lists net and shipping weights for each single frame model.
- Ensure the straps are long enough to maintain a maximum of a 40° angle as shown at detail A in Figure 10.

Table 37: Multi V Water IV Net and Shipping Weights per Frame

Capacity (ton)	Voltage	Net Weight (lbs.)	Shipping Weight (lbs.)
6	208	280	302
8	208	280	302
10	208	280	302
12	208	280	302
6	460	280	302
8	460	280	302
10	460	280	302
12	460	309	331
14	460	309	331
16	460	309	331

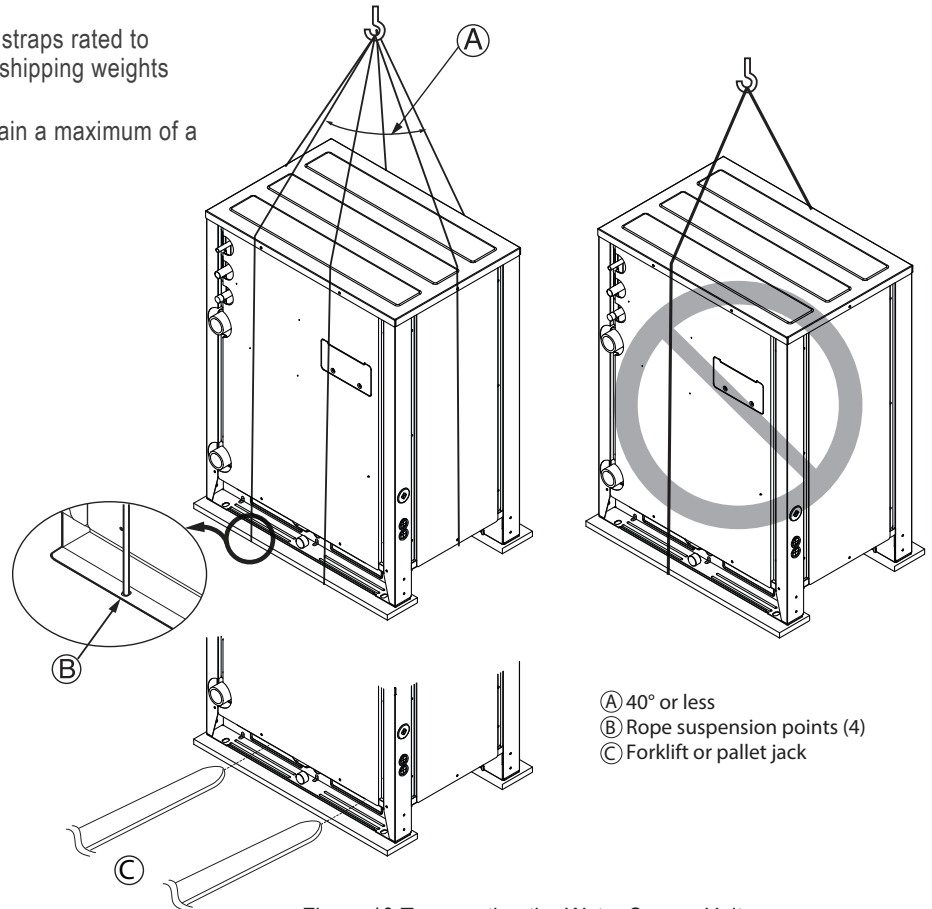

Figure 10: Transporting the Water Source Unit.

### ⚠ WARNING

- Use caution when using forklift to transport an unpackaged unit. Consider the unit's center of gravity when lifting. Protect the painted surfaces as necessary to prevent damage to the unit finish.
- Use appropriate moving equipment to safely transport each frame. Ensure moving equipment is capable of supporting the weight of the water source unit frame. Wear protective gloves when handling the moving equipment and frame.
- Some products include polypropylene bands around the unit for packaging. Do not use polypropylene bands to lift the unit.
- Tear apart and throw away plastic packaging bags so that children can not play with them and risk suffocation and death.
- Lift the water source unit from the base at specified locations. Support the water source unit at a minimum of six (6) points to avoid slippage from the rigging apparatus.
- Do not drop the unit when carrying it with a forklift.
- Use a minimum of three (3) lifting straps.
- Place a protective cloth or other soft material at the locations where the casing comes in contact with the lifting straps to prevent damage to painted surfaces.
- Always know where the center of gravity of the water source unit is before lifting. Hoist the unit with the center of gravity centered among the lifting straps.

**Service Area Requirements**

**Single Frame Installation**

Install a single frame system with the service area requirements shown in Figure 11. If local codes require additional clearance area, comply with local codes.

**Note:**

- Job site conditions may require routing refrigerant piping, condensate pipe, and/or electrical wiring under the unit base. If conditions warrant, consider adding mounting rails under the unit. The unit may need to be elevated above the floor to provide the necessary slope for proper condensate draining on long pipe installations.
- Consult with LG Electronics, U.S.A., Inc. if the available space is less than shown.
- If water piping passes along the side of a frame, ensure the indicated space is available after considering the space taken by the piping.

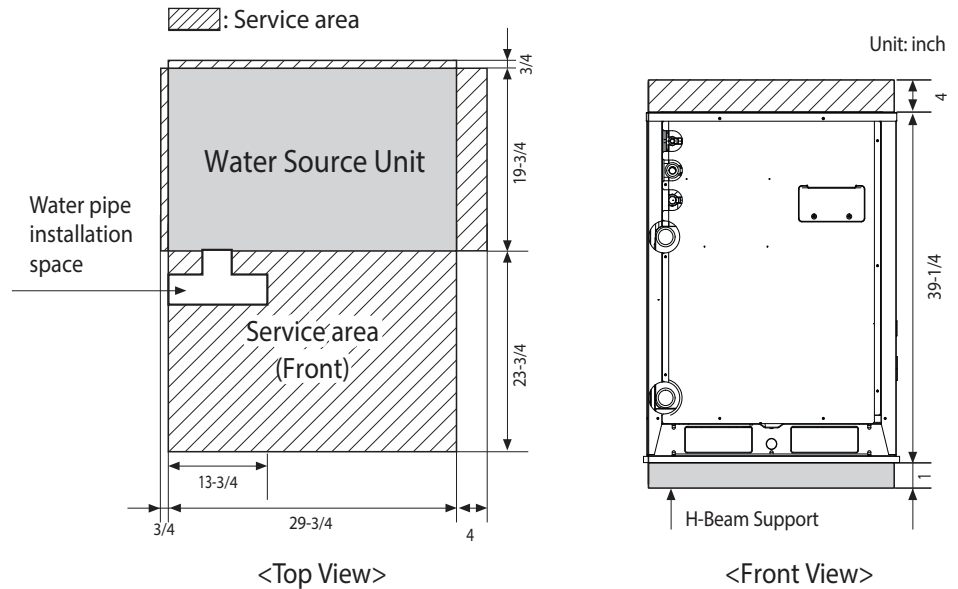

Figure 11: Single Frame Installation.

**Dual Frame Installation**

Install a single frame system with the service area requirements shown in Figure 12. If local codes require additional clearance area, comply with local codes.

**Note:**

- Job site conditions may require routing refrigerant piping, condensate pipe, and/or electrical wiring under the unit base. If conditions warrant, consider adding mounting rails under the units. The units may need to be elevated above the floor to provide the necessary slope for proper condensate draining on long pipe installations.
- Consult with LG Electronics, U.S.A., Inc. if the available space is less than shown.
- If water piping passes along the side of a frame, ensure the indicated space is available after considering the space taken by the piping.

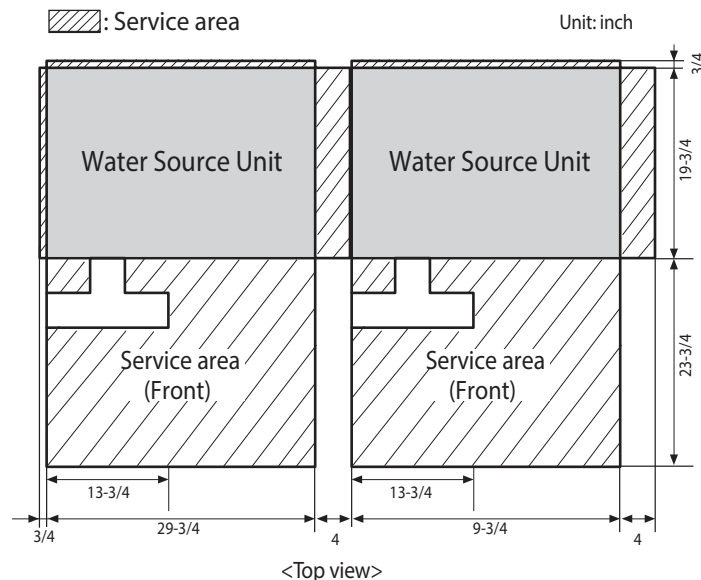

Figure 12: Dual Frame Installation.

# INSTALLATION

## Water Source Unit Minimum Space Requirements

### Triple Frame Installation

Install a single frame system with the service area requirements shown in Figure 13. If local codes require additional clearance area, comply with local codes.

**Note:**

- Job site conditions may require routing refrigerant piping, condensate pipe, and/or electrical wiring under the unit base. If conditions warrant, consider adding mounting rails under the units. The units may need to be elevated above the floor to provide the necessary slope for proper condensate draining on long pipe installations.
- Consult with LG Electronics, U.S.A., Inc. if the available space is less than shown.
- If water piping passes along the side of a frame, ensure the indicated space is available after considering the space taken by the piping.

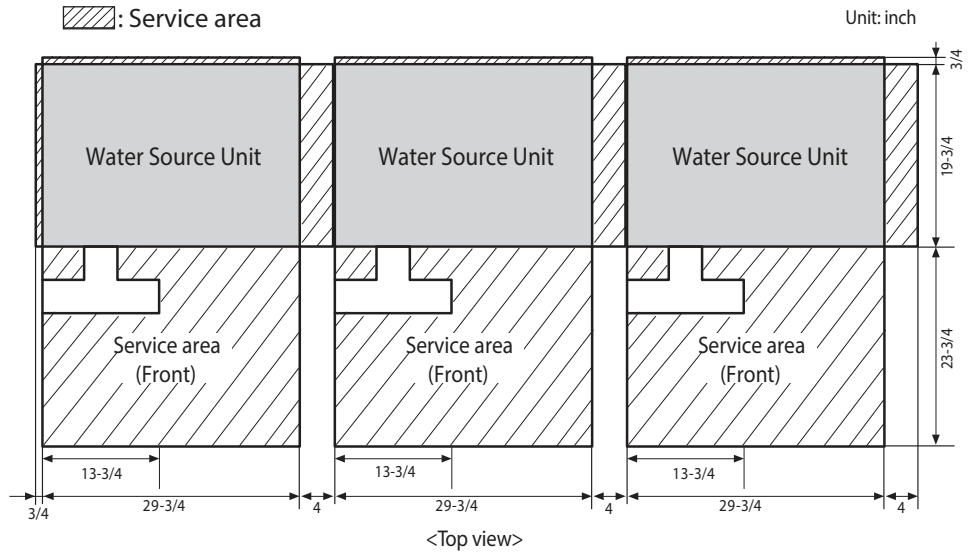

Figure 13: Triple Frame Installation.

### Stacked Frame Installation

Install a single frame system with the service area requirements shown in Figure 14. If local codes require additional clearance area, comply with local codes.

**Note:**

- Job site conditions may require routing refrigerant piping, condensate pipe, and/or electrical wiring under the unit base. If conditions warrant, consider adding mounting rails under the units. The units may need to be elevated above the floor to provide the necessary slope for proper condensate draining on long pipe installations.
- Consult with LG Electronics, U.S.A., Inc. if the available space is less than shown.
- If water piping passes along the side of a frame, ensure the indicated space is available after considering the space taken by the piping.

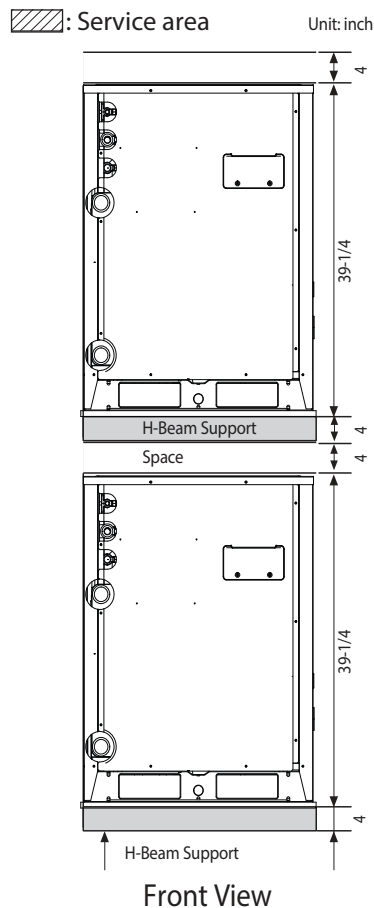

Figure 14: Stacked Frame Installation.

## General Mounting

Securely attach the water source unit to a concrete pad, base rails, or other mounting platform that is anchored to the building structure. Avoid placing the unit in a low lying area where water may accumulate. Refer to the dimensional drawings for single, dual, and triple frame systems on page 24, page 25, and page 26, and follow the applicable local code for clearance, mounting, anchor, and vibration attenuation requirements.

### ⚠ WARNING

- When building a base support for the water source unit, ensure that the floor surface / location has enough strength to support the weight of the unit, enough space for pipes and wiring, and sufficient slope for proper drainage between the units, the condensate drain connection, and the floor drain.
- Install the water source unit to a base and in a manner approved by the structural engineer to minimize damage to the unit in the event of an earthquake. Any deficiency in installation may cause unit to fall, resulting in physical injury or death.

## Anchoring the Water Source Unit

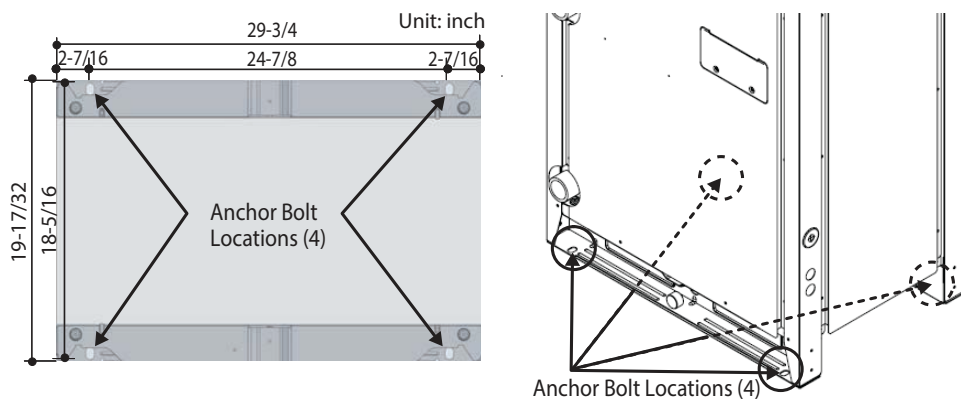

Figure 15: Anchor Bolt Locations.

- Securely fasten all four (4) corners to the supporting base.
- If not otherwise directed by the structural engineer or local codes, Use a 7/16 inch or 1/2 inch diameter J-bolt. Use a hexagon nut with a spring washer.
- Include anti-vibration material chosen by the acoustics engineer.
- Include enough space for refrigerant piping and electrical wiring when installing through the bottom of the unit.
- Use an H-beam, concrete support, or other acceptable support structure designed by a structural engineer.

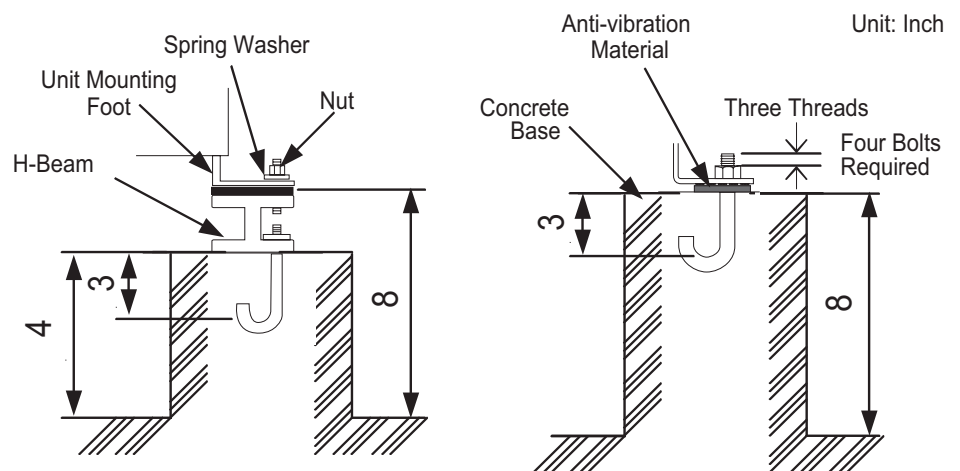

Figure 16: Close up of Anchor Bolts.

### Note:

All referenced materials are to be field-supplied. Images are not to scale, are for reference only, and are not intended to be used for design purposes.

# INSTALLATION

## Heat Recovery Box Minimum Space Requirements

### Note:

Heat recovery units are used with ARWB-series heat recovery systems only.

Select a heat recovery unit installation space that meets the following conditions:

- Install the heat recovery unit indoors in a level and upright position.
- Ensure there is enough space in the installation area for service access.
- Refrigerant pipes must not exceed lengths specified by LG Electronics, U.S.A., Inc.
- Do not install the heat recovery unit in a location where it would be subjected to strong radiated heat from any heat source.
- Avoid an installation environment where oil splattering, vapor spray, or high-frequency electric noise could occur.
- Install the heat recovery unit in a location where any sound it may generate will not disturb occupants in the surrounding rooms.
- Install the refrigerant piping and electrical wiring system in an easily accessible location.
- Condensate drain piping is not required.

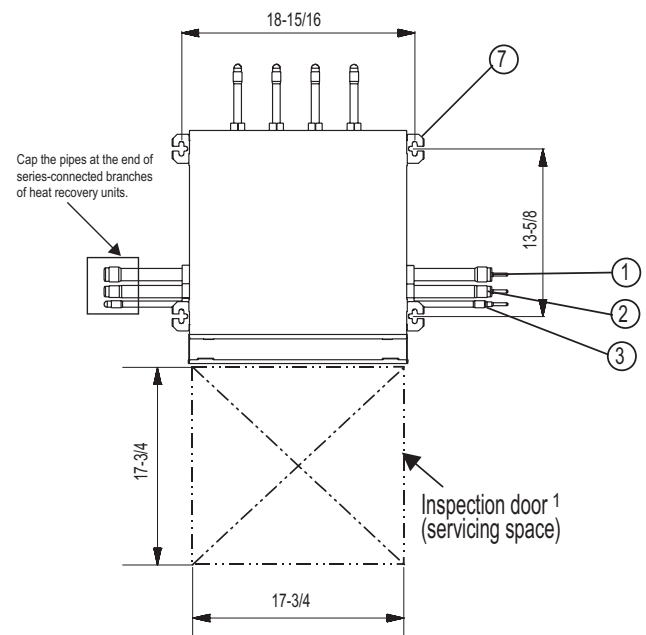
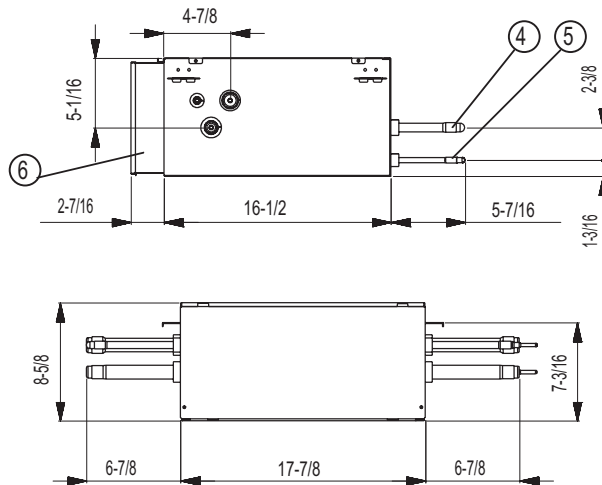

Figure 17: Heat Recovery Unit Dimensions.

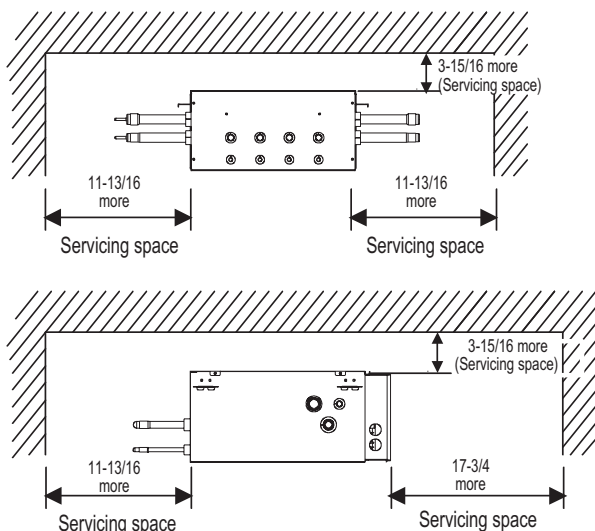

Figure 18: Heat Recovery Unit Minimum Service Clearances.

Table 38: Heat Recovery Unit Parts.

Tag No.	Part Name	Connection Size(in./Type)	
		PRHR022A	PRHR032A/042A
1	Low pressure vapor pipe connection port	7/8 Braze	1-1/8 Braze
2	High pressure vapor pipe connection port	3/4 Braze	7/8 Braze
3	Liquid pipe connection port	3/8 Braze	1/2 Braze
4	Indoor unit vapor pipe connection port	5/8 Braze	5/8 Braze
5	Indoor unit liquid pipe connection port	3/8 Braze	3/8 Braze
6	Control box	-	-
7	Hanger bracket	3/8 or 5/16	3/8 or 5/16

<sup>1</sup>Locate the inspection door at the control box side of the heat recovery unit. If reducers are used, space for service access must be increased to match the dimensions of the reducer.



### LATS Multi V Refrigerant Piping Design Software

**Note:**

LG Electronics U.S.A., Inc., is not responsible for any piping calculations, refrigerant leaks, degradation of performance, or any other potential problems or damages as a result of interconnecting piping, their joint connections, isolation valves, introduced debris inside the piping system, or other problems caused by the interconnecting piping system.

Figure 19: LATS Pipe System Design Tool in Tree Mode.

Proper design and installation of the refrigerant piping system is a critical element of the Multi V Water IV system. A heat pump water source unit installation requires two pipes (liquid line and vapor line) between system components. A heat recovery water source unit installation requires three pipes (liquid, low-pressure vapor, and high-pressure vapor) between system components. A properly designed refrigerant piping system ensures that refrigerant is delivered to the evaporator coil's electronic expansion valve (EEV) in a pure liquid state free of gas bubbles. A proper design also ensures a sufficient refrigerant gas flow rate in the vapor line(s) that eliminates the possibility of refrigeration oil collecting in the vapor line(s).

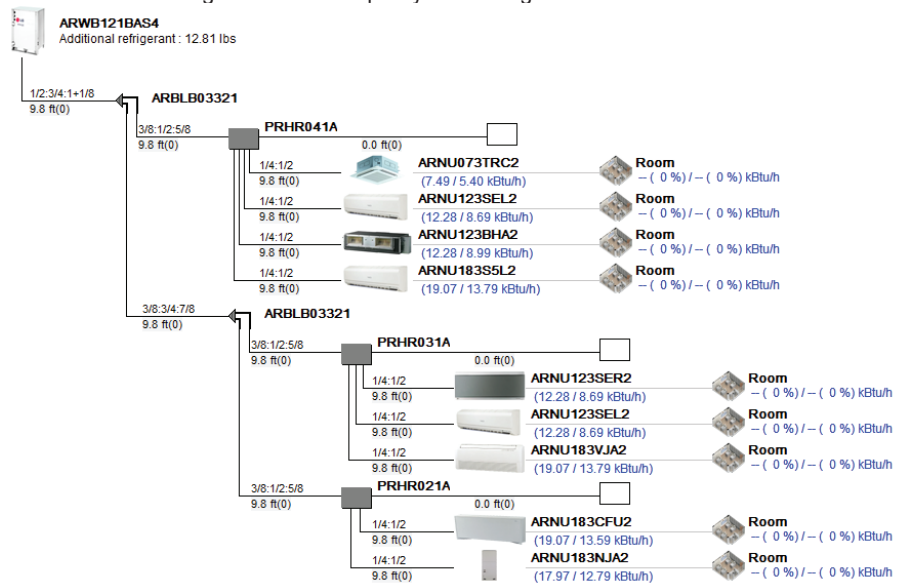

### Piping Quality Assurance

LG Air Conditioning Technical Solution (LATS) Multi V software makes designing the refrigerant system easy. LATS Multi V is a Microsoft Windows®-based application that assists the engineer in refrigeration distribution pipe system design, verifies the design complies with pipe design limitations, applies capacity correction factors, and calculates the system refrigerant charge. The piping system design can be entered manually into LATS from a one-line pipe diagram. **To ensure that the refrigerant piping design meets LG's quality standards, a LATS refrigerant piping design must be provided with every Multi V Water Source Unit order. Following the installation, if any changes or variations to the design were necessary, a new "as-built" LATS piping design software report must be created and provided to LG prior to system commissioning.**

Systems that are close to the standard application piping limits may be converted into a conditional piping application by field changes to pipe equivalent lengths. Always check the LATS report actual pipe layout versus pipe limits. The user may want to increase pipe lengths when design conditions are approaching the Standard Application Piping Rule limits to force the LATS program to engineer the system using the Conditional Application Pipe Rules. This will increase the diameter of the main and a few branch segments to minimize the possibility of required pipe changes due to field installation variations.

### Adjusting LATS Multi V Output for Altitude

When a system is installed at elevations significantly above sea level, consider the impact air density has on the capacity of the indoor and water source units. LATS does not de-rate indoor unit capacity for high altitude applications. Be sure to apply locally accepted altitude correction factors to calculate actual indoor unit capacities at that altitude.

**Note:**

Any field changes such as re-routing piping, shortening or lengthening a pipe segment, adding or eliminating elbows and/or fittings, re-sizing, adding, or eliminating indoor units, changing the mounting height or moving the location of a device or fitting during installation should be done with caution and ALWAYS VERIFIED in LATS MULTI V SOFTWARE BEFORE supplies are purchased or installed. Doing so may lead to a more profitable installation, reduce the potential for rework, and reduce the potential for multiple visits to the job site to complete system commissioning.

### Creating a Balanced Piping System

Unlike designing duct-work or chilled and hot water pipe systems where balancing dampers, ball valves, orifices, circuit setters, or other flow control devices can be installed to modify or balance the flow of cooling medium, these cannot be used in VRF systems. Therefore, VRF system designs must be "self balanced." Balanced liquid refrigerant distribution is solely dependent on the designer choosing the correct pipe size for each segment. Pipe sizing considerations include pipe length, pipe segment pressure drop relative to other pipe segments in the system, type and quantity of elbows, bends, fitting installation orientation, and end use device elevation differences.

**Note:**

It is imperative to avoid creating excessive pressure drop. When liquid refrigerant is subjected to excessive pressure drop, liquid refrigerant will change state and "flash" to vapor. The pipe system must be designed and installed in a manner that avoids the creation of unwanted vapor.

## Device Connection Limitations

The minimum number of connected and operating indoor units in a Multi V Water Source system is one, taking into consideration the minimum combination ratio. The maximum number of indoor units in a system varies according to model:

Heat Pump Model 208-230V/460V	IDU Max. Qty. 208-230V/460V	Heat Recovery Model 208-230V/460V	IDU Max. Qty. 208-230V/460V
ARWN072BAS4 / ARWN072DAS4	13/13	ARWB072BAS4 / ARWB072DAS4	13/13
ARWN096BAS4 / ARWN096DAS4	16/16	ARWB096BAS4 / ARWB096DAS4	16/16
ARWN121BAS4 / ARWN121DAS4	20/20	ARWB121BAS4 / ARWB121DAS4	20/20
ARWN144BAS4 / ARWN144DAS4	23/23	ARWB144BAS4 / ARWB144DAS4	23/23
ARWN168BAS4 / ARWN168DAS4	29/29	ARWB168BAS4 / ARWB168DAS4	29/29
ARWN192BAS4 / ARWN192DAS4	32/32	ARWB192BAS4 / ARWB192DAS4	32/32
ARWN216BAS4 / —	35/—	ARWB216BAS4 / —	35/—
— / ARWN240DAS4	—/39	— / ARWB240DAS4	—/39
ARWN288BAS4 / ARWN288DAS4	45/45	ARWB288BAS4 / ARWB288DAS4	45/45
— / ARWN336DAS4	—/55	— / ARWB336DAS4	—/55
ARWN360BAS4 / —	58/—	ARWB360BAS4 / —	58/—
— / ARWN384DAS4	—/61	— / ARWB384DAS4	—/61
ARWN480BAS4 / ARWN480DAS4	64/64	ARWB432BAS4 / —	64/—
— / ARWN576DAS4	—/64	— / ARWB480DAS4	—/64
		— / ARWB576DAS4	—/64

One of the most critical elements of a Multi V Water Source Unit system is the refrigerant piping. Table 39 lists refrigerant pipe length limits that must be followed in system design and installation:

Table 39: Multi V Water Source Unit Liquid Refrigerant Pipe Design Limitations.

Pipe Length (ELF = Equivalent Length of pipe in Feet)	Longest total equivalent piping length	1640 feet
	Longest distance from water source unit to indoor unit	656 feet (Actual); 738 feet (Equivalent)
	Distance between fittings and indoor units	≥20 inches
	Distance between fittings and Y-branches	≥20 inches
	Distance between two Y-branches	≥20 inches
	Distance between Header and indoor units	≥20 inches
	Minimum distance between indoor unit to any Y-branch	3 feet from indoor unit to Y-branch
	Maximum distance between first Y-branch to farthest indoor unit	≤ 131 feet; (295 ft conditional applications)
Elevation (All Elevation Limitations are Measured in Actual Feet)	Water-source unit above or below indoor unit	≤ 164 feet
	Between any two indoor units (ARWN Series only)	≤ 131 feet
	Between indoor units connected to a heat recovery unit (ARWB Series only)	≤ 49 feet
	Between heat recovery units (ARWB Series only)	≤ 49 feet
	Between indoor units connected to same or series-connected heat recovery units (ARWB Series only)	≤ 49 feet
	Between two indoor units connected to separate Y-branch connected heat recovery units (ARWB Series only)	≤ 131 feet

Table 40: Equivalent Piping Length in Feet for Typical Refrigeration Elbows, Y-Branched, Headers, and Heat Recovery Units.

Component	Elbow Size (Inches)													
	1/4	3/8	1/2	5/8	3/4	7/8	1	1-1/8	1-1/4	1-3/8	1-1/2	1-5/8	1-3/4	2-1/8
Elbow (ft.)	0.5	0.6	0.7	0.8	1.2	1.3	1.5	1.6	1.8	2.0	2.1	2.3	2.5	2.8
Y-branch (ft.) <sup>1</sup>	1.6													
Header (ft.)	3.3													
Heat Recovery Unit (ft) (ARWB Series only)	8.2													

<sup>1</sup>Kit for ARWN Heat Pump systems contains two Y-branches: one for liquid and one for vapor; Kit for ARWB Heat Recovery systems contains three Y-branches: one for liquid, one for low-pressure vapor, one for high-pressure vapor.

## Field-Supplied Copper Tubing

Type ACR copper is the only approved refrigerant pipe material for use with LG Multi V commercial air conditioning products. ACR rated tubing is the only type that ships with yellow caps. Approved tubing for use with Multi V products will be marked “R410 RATED” along the length of the tube.

- Drawn temper (rigid) ACR copper tubing is available in sizes 3/8 through 2-1/8 inches (ASTM B 280, clean, dry, and capped).
- Annealed temper (soft) ACR copper tubing is available in sizes 1/4 through 2-1/8 inches (ASTM B 280, clean, dry, and capped).

Tube wall thickness should meet local code requirements and be approved for a maximum operating pressure of 551 psi. When bending tubing, try to keep the number of bends to a minimum, and use the largest radii possible to reduce the equivalent length of installed pipe; also, bending radii greater than ten (10) pipe diameters can minimize pressure drop. Be sure no traps or sags are present when rolling out soft copper tubing coils.

### Note:

- Commercially available piping often contains dust and other materials. Always blow piping clean with a dry inert gas.
- Prevent dust, water or other contaminants from entering the piping during installation.

Table 41: ACR Copper Tubing Material.

Type	Seamless Phosphorous Deoxidized
Class	UNS C12200 DHP
Straight Lengths	H58 Temper
Coils	O60 Temper

Table 42: Piping Tube Thicknesses.

OD (in)	1/4	3/8	1/2	5/8	3/4	7/8	1-1/8	1-3/8
Material	Rigid or Soft ACR rated for R410A			Rigid or Solid ACR rated for R410A				
Min. Bend Radius (in)	.563	.9375	1.5	2.25	3.0	3.0	3.5	4.0
Min. Wall Thickness (in)	.03	.03	.035	.040	.042	.045	.050	.050

Table 43: ACR Copper Tubing Dimensions and Physical Characteristics<sup>1-4</sup>

Nominal Pipe Outside Diameter (in)	Actual Outside Diameter (in)	Drawn Temper			Annealed Temper		
		Nominal Wall Thickness (in)	Weight (lb/ft)	Cubic ft per Linear ft	Nominal Wall Thickness (in)	Weight (lb/ft)	Cubic ft per Linear ft
1/4	0.250	--	--	--	0.030	0.081	.00020
3/8	0.375	0.030	0.126	.00054	0.032	0.134	.00053
1/2	0.500	0.035	0.198	.00101	0.032	0.182	.00103
5/8	0.625	0.040	0.285	.00162	0.035	0.251	.00168
3/4	0.750	0.042	0.362	.00242	0.042	0.362	.00242
7/8	0.875	0.045	0.455	.00336	0.045	0.455	.00336
1-1/8	1.125	0.050	0.655	.00573	0.050	0.655	.00573

<sup>1</sup>All dimensions provided are in accordance with ASTM B280 – Standard.

<sup>2</sup>Design pressure = 551 psig.

<sup>3</sup>ACR Tubing is available as hard drawn or annealed (soft) and is suitable for use with R410A refrigerant.

<sup>4</sup>The Copper Tube Handbook, 2010, Copper Development Association Inc., 260 Madison Avenue, New York, NY 10016.

## LG Engineered Y-branch Kits and Header Kits

### Note: No Substitutions

Only LG supplied Y-branch fittings can be used to join one pipe segment to two or more segments. Third-party or field-fabricated Tee's, Y-fittings, Headers, or other branch fittings are not qualified for use with LG Multi V IV systems. The only field-provided fittings allowed in a Multi V IV piping system are 45° and 90° elbows.

Table 44: Y-Branch and Header Kits.

Y-Branch Kits				Header Kits		
Heat Pump (HP)		Heat Recovery (HR)		4 Branch	7 Branch	10 Branch
WSU	IDU	WSU	IDU			
ARCNN21	ARBLN01621	ARCNB21	ARBLB01621	ARBL054	ARBL057	ARBL1010
ARCNN31	ARBLN03321	ARCNB31	ARBLB03321	ARBL104	ARBL107	ARBL2010
—	ARBLN07121	—	ARBLB07121	—	—	—
—	ARBLN14521	—	ARBLB14521	—	—	—

- If the diameter of the branch pipe segments differ from that of the designated refrigerant piping, trim the to the desired section using a pipe cutter, and then use an adapter to connect.
- Always follow manufacturer's guidelines on refrigerant piping restrictions such as maximum length, elevation difference, and diameters. Failure to do so can result in reduced heating / cooling performance or equipment malfunction.

### Y-Branch Kits

LG Y-branch and kits are highly engineered devices designed to evenly divide the flow of refrigerant, and are used to join one pipe segment to two or more segments. There are two types of Y-branches used in LG VRF systems: Y-branches that combine two or three water source units to make one large-capacity water source unit (also known as multi-frame connectors), or Y-branches used with the indoor units in the refrigerant piping system at each transition. Field-supplied "T" fittings or "Y" branches will not be accepted. Do not install Y-branches backwards; refrigerant flow cannot make U-turns through Y-branches. The equivalent pipe length of each Y-branch (1.6') must be added to each pipe segment entered into LATS piping design software.

### LG Y-Branch Kits Consist of:

- Y-branches:
  - For heat pump systems - one liquid line and one vapor line (two [2] total)
  - For heat recovery systems - one liquid line, one low-pressure vapor line, and one high-pressure vapor line (three [3] total)
- Reducer fittings as applicable.
- Molded clam-shell type peel and stick insulation covers.

### Indoor Unit Y-Branches

Indoor unit Y-branches may be installed in horizontal or vertical configurations. When installed vertically, position the Y-branch so the straight-through leg is within  $\pm 3^\circ$  of plumb. When installed horizontally, position the Y-branch so the take-off leg is level and shares the same horizontal plane as the straight-through leg within  $\pm 5^\circ$  rotation.

Indoor unit Y-branches must always be installed with the single port end towards the water source unit, the two-port end towards the indoor units (or heat recovery units for heat recovery systems only). If indoor unit Y-branches are used to combine heat recovery ports to accommodate an indoor unit with a capacity of six (6) tons or larger, then the single port end must be installed with the single port end towards the indoor unit and the two-

Figure 23: Incorrect WSU Y-branch Installation.

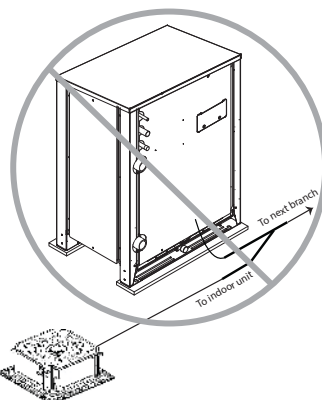

Figure 21: Indoor Unit Y-branch Vertical Installation Alignment Specification.

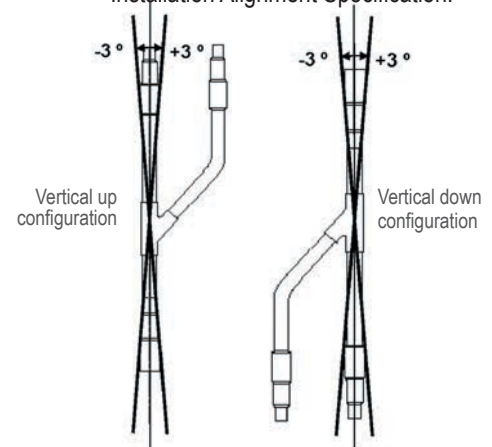
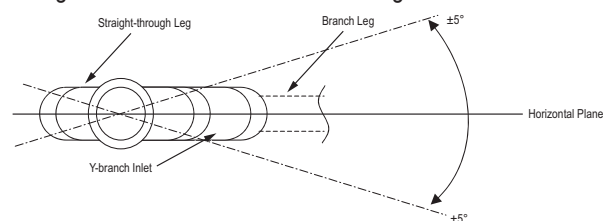

Figure 20: Top View of Indoor Unit Y-branch Horizontal Installation.



Figure 22: Y-Branch Horizontal Configuration End View.



port end towards the heat recovery unit. The first indoor unit Y-branch kit must be located at least three (3) feet from the water source unit. Provide a minimum of twenty (20) inches between a Y-branch and any other fittings or indoor unit piped in series.

There is no limitation on the number of indoor unit Y-branches that can be installed, but there is a limitation on the number of indoor units connected to a single water source unit. It is recommended that when a Y-branch is located in a pipe chase or other concealed space, access doors should be provided for inspection access.

## Water Source Unit Y-Branches

Water source unit Y-branches can only be installed in a horizontal or vertical UP configuration. The vertical DOWN configuration is not permitted. When installed vertically, position the Y-branch at a level lower than the outdoor units it serves, so the straight-through leg is within  $\pm 3^\circ$  of plumb. When installed horizontally, position the Y-branch so the take-off leg is level and shares the same horizontal plane as the straight-through leg within  $\pm 5^\circ$  rotation.

Water source unit Y-branches must always be installed with the two-port ends connected to the piping coming from the water source units, and the single port end towards the indoor unit refrigerant piping system supporting the indoor units. Water source unit Y-branches are usually installed close to the water source unit, leaving enough space for servicing and maintenance.

## Header Kits

### Note: Install Correctly

- Y-branches can be installed upstream between a header and the WSU, but a Y-branch cannot be installed between a header and an IDU.
- To avoid the potential of uneven refrigerant distribution through a header fitting, minimize the difference in equivalent pipe length between the header fitting and each connected indoor unit.

### LG Header kits consist of:

- Headers (Qty 2 for all kits)
- Reducer fittings as applicable
- Molded clam-shell type insulation covers

Header kits are intended for use where multiple indoor units are in the same vicinity and it would be better to “home-run” the run-out pipes back to a centralized location. If connecting multiple indoor units that are far apart, Y-branches may be more economical. See “Header Kits” on page 41 for specifications and capacities.

Y-branches can be installed between the header and the water source unit, but a Y-branch cannot be installed between a header and an indoor unit. Headers must be installed in a horizontal and level position with the distribution ports of the fitting in the same horizontal plane as the straight-through branch (Figure 25).

When connecting indoor units to a header, always connect the unit with the largest nominal capacity to the port closest to the water source unit. Then install the next largest indoor unit to the next port, working down to the smallest indoor unit. Do not skip ports.

All indoor units connected to a single header fitting should be located with an elevation difference between indoor units that does not exceed 131 feet. If indoor units are located at an elevation the same as or above the header fitting, do not use a header. Instead, install a Y-branch fitting between the water source unit and the header fitting, and connect the elevated indoor unit to the Y-branch.

## Header Insulation

Each header kit comes with two (heat pump kits) or three (heat recovery kits) clam-shell type peel and stick insulation jackets molded to fit the header fittings (Figure 26).

Figure 24: Y-branch Insulation and Pipe Detail.

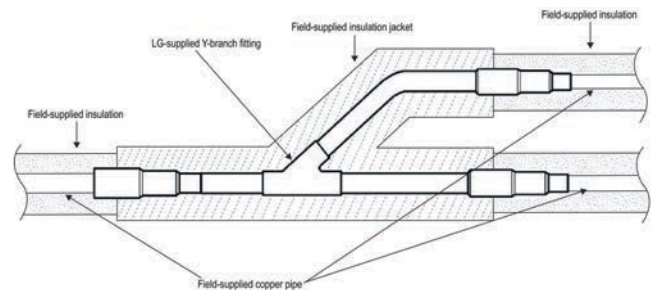

Figure 25: Header Horizontal Rotation Limit—Install Level with No Rotation.

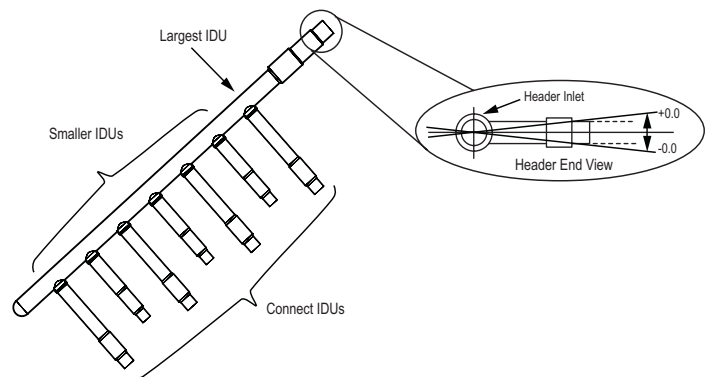
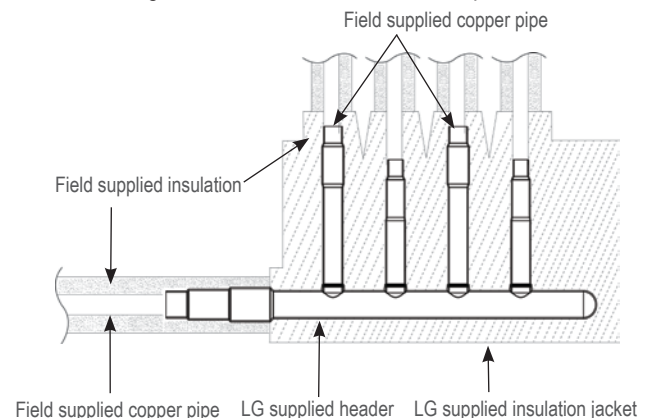

Figure 26: Header Insulation and Pipe Detail.



## No Pipe Size Substitutions

Use only the pipe size selected by the LATS Multi V pipe system design software. Using a different size is prohibited and may result in a system malfunction or failure to operate.

## Obstacles

Refer to Figure 27. When an obstacle, such as an I-beam or concrete T, is in the path of the planned refrigerant pipe run, it is best practice to route the pipe over the obstacle. If adequate space is not available to route the insulated pipe over the obstacle, then route the pipe under the obstacle. In either case, it is imperative the length of the horizontal section of pipe above or below the obstacle be a minimum of three (3)

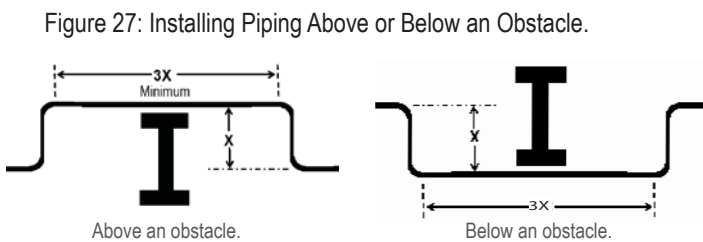

Figure 27: Installing Piping Above or Below an Obstacle.

times the longest vertical rise (or fall) at either end of the segment.

## Copper Expansion and Contraction

Under normal operating conditions, the vapor pipe temperature of a Multi IV system can vary as much as 160°F. With this large variance in pipe temperature, the designer must consider pipe expansion and contraction to avoid pipe and fitting fatigue failures.

Refrigerant pipe along with the insulation jacket form a cohesive unit that expands and contracts together. During system operation, thermal heat transfer occurs between the pipe and the surrounding insulation.

If the pipe is mounted in free air space, no natural restriction to movement is present if mounting clamps are properly spaced and installed. When the refrigerant pipe is mounted underground in a utility duct stacked among other pipes, natural restriction to linear movement is present. In extreme cases, the restrictive force of surface friction between insulating jackets could become so great that natural expansion ceases and the pipe is “fixed” in place. In this situation, opposing force caused by change in refrigerant fluid/vapor temperature can lead to pipe/fitting stress failure.

The refrigerant pipe support system must be engineered to allow free expansion to occur. When a segment of pipe is mounted between two fixed points, provisions must be provided to allow pipe expansion to naturally occur. The most common method is the inclusion of expansion Loop or U-bends as shown in Figure 28. Each segment of pipe has a natural fixed point where no movement occurs. This fixed point is located at the center point of the segment assuming the

entire pipe is insulated in a similar fashion. The natural fixed point of the pipe segment is typically where the expansion Loop or U-bend should be. Linear pipe expansion can be calculated using the following formula:

LE = C x L x (T<sub>r</sub> - T<sub>a</sub>) x 12, where:

- LE = Anticipated linear tubing expansion (in.)
- C = Constant (For copper = 9.2 x 10<sup>-6</sup> in./in.°F)
- L = Length of pipe (ft.)
- T<sub>R</sub> = Refrigerant pipe temperature (°F)
- T<sub>a</sub> = Ambient air temperature (°F)
- 12 = feet to Inches conversion (12 in./ft.)

1. In Table 45, find the row corresponding with the actual length of the straight pipe segment.
2. Estimate the minimum and maximum temperature of the pipe. In the column showing the minimum pipe temperature, find the anticipated expansion distance. Do the same for the maximum pipe temperature.
3. Calculate the difference in the two expansion distance values. The result is the anticipated change in pipe length.

### Example:

A Multi V system is installed and the design shows that there is a 130 feet straight segment of tubing between a Y-branch and an indoor unit. In heating, this pipe transports hot gas vapor to the indoor units at 120°F. In cooling, the same tube is a suction line returning refrigerant vapor to the water source unit at 40°F. Look up the copper tubing expansion at each temperature and calculate the difference.

### Vapor Line

Transporting Hot Vapor: 130 ft. pipe at 120°F = 1.54 in.  
 Transporting Suction Vapor: 130 ft. pipe at 40°F = 0.52 in.  
 Anticipated Change in Length: 1.54 in. - 0.52 in. = 1.02 in.

### Liquid Line

The liquid temperature remains relatively the same temperature; only the direction of flow will reverse. Therefore, no significant change in length of the liquid line is anticipated.

When creating an expansion joint, the joint height should be a minimum of two times the joint width. Although different types of expansion arrangements are available, the data for correctly sizing an expansion loop is listed in Table 46. Use soft copper with long radius bends on longer runs or long radius elbows for shorter pipe segments. Using the anticipated linear expansion (LE) distance calculated, look up the expansion loop or U-bend minimum design dimensions. If other types of expansion joints are chosen, design per ASTM B-88 Standards.

Refer to Table 45 for precalculated anticipated expansion for various pipe sizes and lengths of refrigerant tubing.

**To find the anticipated expansion value:**

1. In Table 45, find the row corresponding with the actual feet of the straight pipe segment.
2. Estimate the minimum and maximum temperature of the pipe.
3. In the column showing the minimum pipe temperature, look up the anticipated expansion distance corresponding to the segment length. Do the same for the maximum pipe temperature.
4. Calculate the difference in the two expansion distance values. The result is the anticipated change in pipe length.

Table 45: Linear Thermal Expansion of Copper Tubing in Inches.

Pipe Length <sup>1</sup>	Fluid Temperature °F																			
	35°	40°	45°	50°	55°	60°	65°	70°	75°	80°	85°	90°	95°	100°	105°	110°	115°	120°	125°	130°
10	0.04	0.04	0.05	0.06	0.06	0.07	0.08	0.08	0.09	0.09	0.10	0.10	0.11	0.11	0.11	0.12	0.13	0.14	0.15	0.15
20	0.08	0.08	0.10	0.12	0.13	0.14	0.15	0.16	0.17	0.18	0.19	0.20	0.21	0.22	0.22	0.23	0.26	0.28	0.29	0.30
30	0.12	0.12	0.15	0.18	0.20	0.21	0.23	0.24	0.26	0.27	0.29	0.30	0.32	0.33	0.32	0.35	0.39	0.42	0.44	0.45
40	0.16	0.16	0.20	0.24	0.26	0.28	0.30	0.32	0.34	0.36	0.38	0.40	0.42	0.44	0.43	0.46	0.52	0.56	0.58	0.60
50	0.20	0.20	0.25	0.30	0.33	0.35	0.38	0.40	0.43	0.45	0.48	0.50	0.53	0.55	0.54	0.58	0.65	0.70	0.73	0.75
60	0.24	0.24	0.30	0.36	0.39	0.42	0.45	0.48	0.51	0.54	0.57	0.60	0.63	0.66	0.65	0.69	0.78	0.84	0.87	0.90
70	0.28	0.28	0.35	0.42	0.46	0.49	0.53	0.56	0.60	0.63	0.67	0.70	0.74	0.77	0.76	0.81	0.91	0.98	1.02	1.05
80	0.32	0.32	0.40	0.48	0.52	0.56	0.60	0.64	0.68	0.72	0.76	0.80	0.84	0.88	0.86	0.92	1.04	1.12	1.16	1.20
90	0.36	0.36	0.45	0.54	0.59	0.63	0.68	0.72	0.77	0.81	0.86	0.90	0.95	0.99	0.97	1.04	1.17	1.26	1.31	1.35
100	0.40	0.40	0.50	0.60	0.65	0.70	0.75	0.80	0.85	0.90	0.95	1.00	1.05	1.10	1.08	1.15	1.30	1.40	1.45	1.50
120	0.48	0.48	0.60	0.72	0.78	0.84	0.90	0.96	1.02	1.08	1.14	1.20	1.26	1.32	1.30	1.38	1.56	1.68	1.74	1.80
140	0.56	0.56	0.70	0.84	0.91	0.98	1.05	1.12	1.19	1.26	1.33	1.40	1.47	1.54	1.51	1.61	1.82	1.96	2.03	2.10
160	0.64	0.64	0.80	0.96	1.04	1.12	1.20	1.28	1.36	1.44	1.52	1.60	1.68	1.76	1.73	1.84	2.08	2.24	2.32	2.40
180	0.72	0.72	0.90	1.08	1.17	1.26	1.35	1.44	1.53	1.62	1.71	1.80	1.89	1.98	1.94	2.07	2.34	2.52	2.61	2.70
200	0.80	0.80	1.00	1.20	1.30	1.40	1.50	1.60	1.70	1.80	1.90	2.00	2.10	2.20	2.16	2.30	2.60	2.80	2.90	3.00
220	0.88	0.88	1.10	1.32	1.43	1.54	1.65	1.76	1.87	1.98	2.09	2.20	2.31	2.42	2.38	2.53	2.86	3.08	3.19	3.30
240	0.96	0.96	1.20	1.44	1.56	1.68	1.80	1.92	2.04	2.16	2.28	2.40	2.52	2.64	2.59	2.76	3.12	3.36	3.48	3.60
260	1.04	1.04	1.30	1.56	1.69	1.82	1.95	2.08	2.21	2.34	2.47	2.60	2.73	2.86	2.81	2.99	3.38	3.64	3.77	3.90
280	1.12	1.12	1.40	1.68	1.82	1.96	2.10	2.24	2.38	2.52	2.66	2.80	2.94	3.08	3.02	3.22	3.64	3.92	4.06	4.20
300	1.20	1.20	1.50	1.80	1.95	2.10	2.25	2.40	2.55	2.70	2.85	3.00	3.15	3.30	3.24	3.45	3.90	4.20	4.35	4.50
320	1.28	1.28	1.60	1.92	2.08	2.24	2.40	2.56	2.72	2.88	3.04	3.20	3.36	3.52	3.46	3.68	4.16	4.48	4.64	4.80
340	1.36	1.36	1.70	2.04	2.21	2.38	2.55	2.72	2.89	3.06	3.23	3.40	3.57	3.74	3.67	3.91	4.42	4.76	4.93	5.10
360	1.44	1.44	1.80	2.16	2.34	2.52	2.70	2.88	3.06	3.24	3.42	3.60	3.78	3.96	3.89	4.14	4.68	5.04	5.22	5.40
380	1.52	1.52	1.90	2.28	2.47	2.66	2.85	3.04	3.23	3.42	3.61	3.80	3.99	4.18	4.10	4.37	4.94	5.32	5.51	5.70
400	1.60	1.60	2.00	2.40	2.60	2.80	3.00	3.20	3.40	3.60	3.80	4.00	4.20	4.40	4.32	4.60	5.20	5.60	5.80	6.00
420	1.68	1.68	2.10	2.52	2.73	2.94	3.15	3.36	3.57	3.78	3.99	4.20	4.41	4.62	4.54	4.83	5.46	5.88	6.09	6.30
440	1.76	1.76	2.20	2.64	2.86	3.08	3.30	3.52	3.74	3.96	4.18	4.40	4.62	4.84	4.75	5.06	5.72	6.16	6.38	6.60
460	1.84	1.84	2.30	2.76	2.99	3.22	3.45	3.68	3.91	4.14	4.37	4.60	4.83	5.06	4.97	5.29	5.98	6.44	6.67	6.90
480	1.92	1.92	2.40	2.88	3.12	3.36	3.60	3.84	4.08	4.32	4.56	4.80	5.04	5.28	5.18	5.52	6.24	6.72	6.96	7.20
500	2.00	2.00	2.50	3.00	3.25	3.50	3.75	4.00	4.25	4.50	4.75	5.00	5.25	5.50	5.40	5.75	6.50	7.00	7.25	7.50

<sup>1</sup>Pipe length baseline temperature = 0°F. "Expansion of Carbon, Copper and Stainless Steel Pipe," *The Engineers' Toolbox*, [www.engineeringtoolbox.com](http://www.engineeringtoolbox.com).

Figure 28: Coiled Expansion Loops and Offsets.

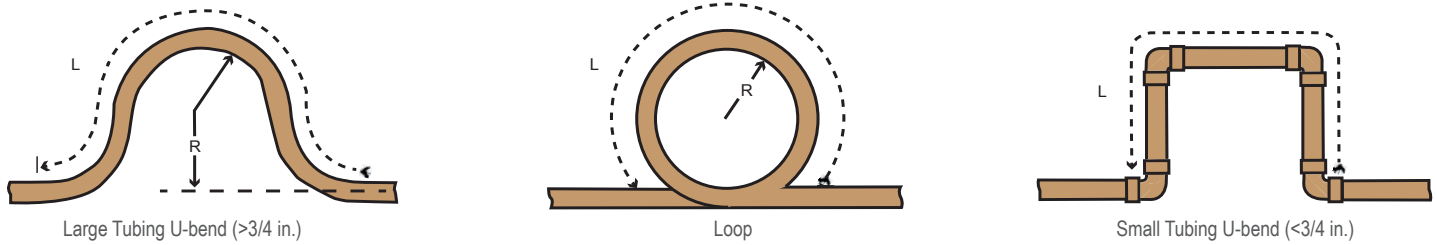

Table 46: Radii of Coiled Expansion Loops and Developed Lengths of Expansion Offsets.

Anticipated Linear Expansion (LE) (in)		Nominal Tube Size (OD) inches						
		1/4	3/8	1/2	3/4	1	1-1/4	1-1/2
1/2	R <sup>1</sup>	6	7	8	9	11	12	13
	L <sup>2</sup>	38	44	50	59	67	74	80
1	R <sup>1</sup>	9	10	11	13	15	17	18
	L <sup>2</sup>	54	63	70	83	94	104	113
1-1/2	R <sup>1</sup>	11	12	14	16	18	20	22
	L <sup>2</sup>	66	77	86	101	115	127	138
2	R <sup>1</sup>	12	14	16	19	21	23	25
	L <sup>2</sup>	77	89	99	117	133	147	160
2-1/2	R <sup>1</sup>	14	16	18	21	24	26	29
	L <sup>2</sup>	86	99	111	131	149	165	179
3	R <sup>1</sup>	15	17	19	23	26	29	31
	L <sup>2</sup>	94	109	122	143	163	180	196
3-1/2	R <sup>1</sup>	16	19	21	25	28	31	34
	L <sup>2</sup>	102	117	131	155	176	195	212
4	R <sup>1</sup>	17	20	22	26	30	33	36
	L <sup>2</sup>	109	126	140	166	188	208	226

<sup>1</sup>R = Center line Length of Pipe.

<sup>2</sup>L = Center line Minimum Radius (inches).



## Pipe Bends

When bending soft copper, use long radius bends. Refer to Table 46 for minimum radius specifications.

## In-line Refrigeration Components

Components such as oil traps, solenoid valves, filter-dryers, sight glasses, tee fittings, and other after-market accessories are not permitted on the refrigerant piping system between the water source units and the indoor units. Multi V Water Source Unit systems have redundant systems that assure oil is properly returned to the compressor. Sight-glasses and solenoid valves may cause vapor to form in the liquid stream. Over time, dryers may deteriorate and introduce debris into the system. The designer and installer should verify the refrigerant piping system is free of traps, sagging pipes, sight glasses, filter dryers, etc.

## Field-Provided Isolation Ball Valves

LG maintains a neutral position on using isolation valves in VRF refrigerant piping systems. LG does not endorse any manufacturer of isolation valves. It is recognized that installing isolation valves may simplify future maintenance requirements, and, if used, considerations should be taken including, but not limited to, the following:

- Pressure drops for any component used, including isolation valves, must be known in equivalent pipe length and calculated into the total and segment equivalent piping lengths and compared to product design limitations.
- In all cases, materials must be suitable for the application and any applicable codes, including, but not limited to, diameter and wall thickness continuity per ACR standards.

Failure to do so may cause significant performance degradation. Proper leak checks must be performed. Using isolation valves does not automatically void any LG product warranty; however, a limited warranty may be voided in whole or part should any field supplied accessory fail in any way that causes product failure.

## Using Elbows

Field supplied elbows are allowed as long as they are designed for use with R410A refrigerant. The designer and installer, however, should be cautious with the quantity and size of fittings used, and must account for the additional pressure losses in equivalent pipe length calculation for each branch. The equivalent pipe length of each elbow must be added to each pipe segment in the LATS program. See Table 40 for equivalent lengths.

## Installation of Refrigerant Piping/Brazing Practice

### Note:

*It is imperative to keep the piping system free of contaminants and debris such as copper burrs, slag, or carbon dust during installation.*

1. All joints are brazed in the field. Multi V Water Source Unit refrigeration system components contain very small capillary tubes, small orifices, electronic expansion valves, oil separators, and heat exchangers that can easily become blocked. Proper system operation depends on the installer using best practices and utmost care while assembling the piping system.

- Store pipe stock in a dry place; keep stored pipe capped and clean.
  - Blow clean all pipe sections with dry nitrogen prior to assembly.
2. Proper system operation depends on the installer using best practices and the utmost care while assembling the piping system.
- Use adapters to assemble different sizes of pipe.
  - Always use a non-oxidizing material for brazing. Do not use flux, soft solder, or anti-oxidant agents. If the proper material is not used, oxidized film may accumulate and clog or damage the compressors. Flux can harm the copper piping or refrigerant oil.
  - Use a tubing cutter to cut pipe; do not use a saw. De-bur and clean all cuts before assembly.

3. Brazing joints:

- Use a dry nitrogen purge operating at a minimum pressure of three (3) psig and maintain a steady flow.
- Use a 15% silver phosphorous copper brazing alloy to produce good flow and avoid overheating.
- Protect isolation valves, electronic expansion valves, and other heat-sensitive control components from excessive heat with a wet rag or heat barrier spray.

Figure 29: Refrigerant Pipe Brazing.

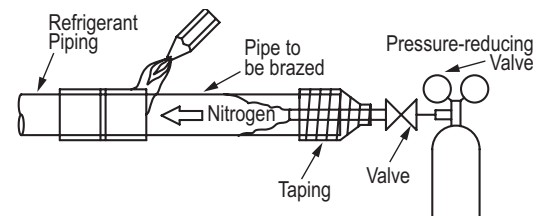

## Pipe Supports

A properly installed pipe system includes adequate support to avoid pipe sagging. Sagging pipes become oil traps that lead to equipment malfunction.

Pipe supports should never touch the pipe wall; supports shall be installed outside (around) the primary pipe insulation jacket (see Figure 30). Insulate the pipe first because pipe supports shall be installed outside (around) the primary pipe insulation jacket. Clevis hangers should be used with shields between the hangers and insulation. Field provided pipe supports should be designed to meet local codes. If allowed by code, use fiber straps or split-ring hangers suspended from the ceiling on all-thread rods (fiber straps or split-ring hangers can be used as long as they do not compress the pipe insulation). Place a second layer of insulation over the pipe insulation jacket to prevent chafing and compression of the primary insulation within the confines of the support pipe clamp.

A properly installed pipe system will have sufficient support to prevent pipe sagging during the life of the system. As necessary, place supports closer for segments where potential sagging could occur. Maximum spacing of pipe supports shall meet local codes.

If local codes do not specify pipe support spacing, pipe shall be supported:

- Maximum of five feet (5') on center for straight segments of pipe up to 3/4" outside diameter (OD) size.
- Maximum of six feet (6') on center for pipe from 3/4" (OD) up to one inch (1") OD size.
- Maximum of eight feet (8') on center for pipe from one inch (1") OD to two inches (2") OD size.

Wherever the pipe changes direction, place a hanger within twelve (12) inches on one side and within twelve to nineteen (12 to 19) inches of the bend on the other side as shown in Figure 31. Support piping at indoor units as shown in Figure 32. Support Y-Branch and Header fittings as shown in Figure 33 and Figure 34.

Figure 30: Pipe Hanger Details.

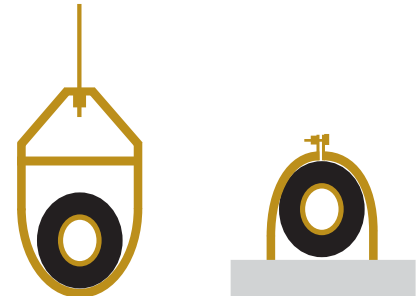

Figure 31: Typical Pipe Support Location—Change in Pipe Direction.

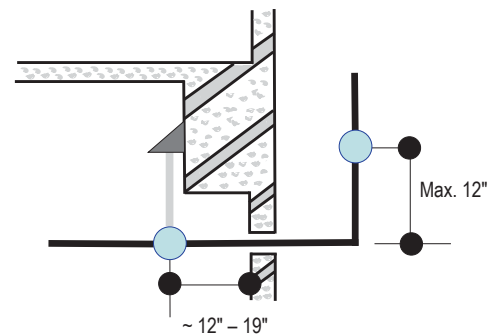

Figure 32: Pipe Support at Indoor Unit.

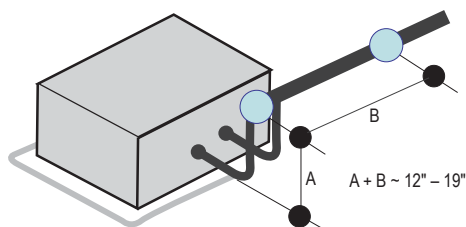

Figure 33: Pipe Support at Y-branch Fitting.

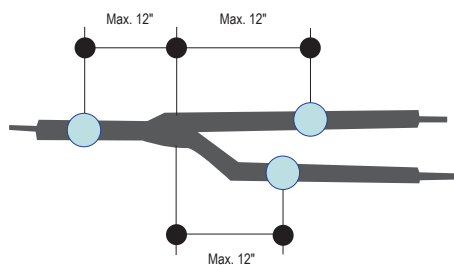
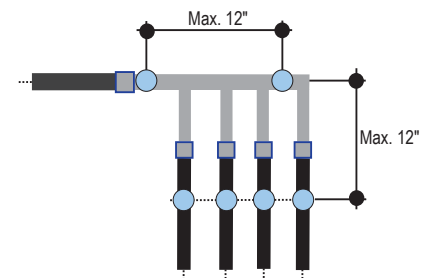

Figure 34: Pipe Support at Header Fitting.



## Pipe Slope

The horizontal pipe slope cannot exceed 10° up or down.

## Pipe Sleeves and Wall Penetrations

LG requires that all pipe penetrations through walls and floors be properly insulated and routed through an appropriate wall sleeve of sufficient size to prevent compression of refrigerant pipe insulation and allow free movement of the pipe in the sleeve.

Figure 35: Typical Pipe Penetration.

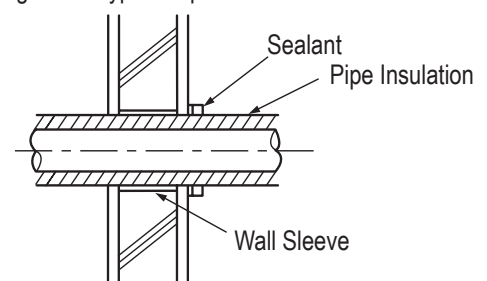

### Triple-Frame Heat Pump Water Source Unit Connections

Figure 36: Heat Pump Triple-Frame Refrigerant Pipe Connections.

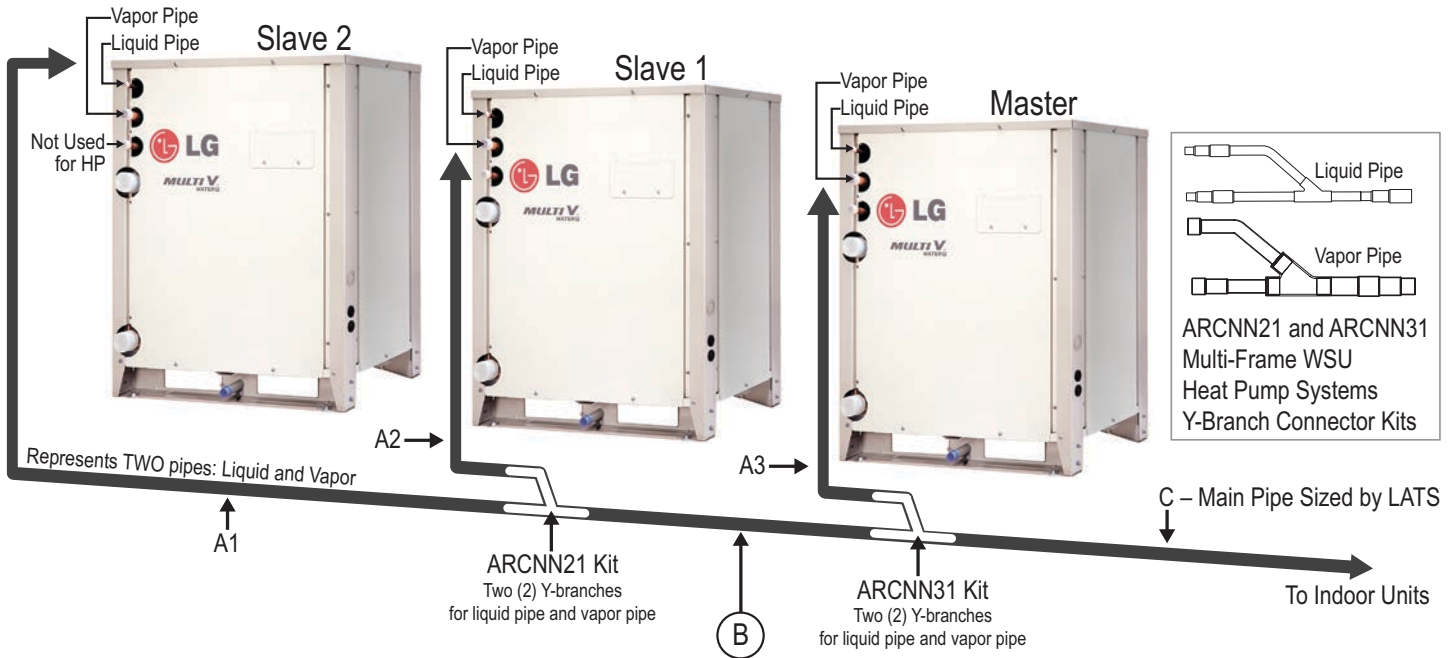

### Refrigerant Pipe Sizes for WSU Connections

- Figure 36 is for reference only, is not to scale, and does not represent required pipe routing.
- Multi-frame Y-branches MUST be installed horizontally as shown in Figure 22.
- A1, A2, and A3 pipe diameters match the water source unit connection diameters.
- Main pipe C diameters are sized by LATS.
- See Table 47 for B pipe diameters.

Table 47: Heat Pump Triple-Frame Connection Pipe Sizes.

WSU System Size (tons)	WSU System Model	Master Frame	Slave 1 Frame	Slave 2 Frame	B Pipe (in. OD) If Equivalent Pipe Length from WSU to Farthest IDU is <295 ft.		B Pipe (in. OD) If Equivalent Pipe Length from WSU to Farthest IDU is ≥295 ft.	
					Liquid	Vapor	Liquid	Vapor
30	ARWN360BAS4	ARWN144BAS4	ARWN144BAS4	ARWN072BAS4	3/4	1-3/8	7/8	1-5/8
36	ARWN432BAS4	ARWN144BAS4	ARWN144BAS4	ARWN144BAS4	3/4	1-3/8	7/8	1-5/8
40	ARWB480DAS4	ARWB192DAS4	ARWB144DAS4	ARWB144DAS4	3/4	1-3/8	7/8	1-5/8
48	ARWB576DAS4	ARWB192DAS4	ARWB192DAS4	ARWB192DAS4	3/4	1-3/8	7/8	1-5/8

### Note:

- Larger-capacity water source units must be the master in a multi-frame system.
- Master water source unit capacity must be greater than or equal to the Slave 1 water source unit capacity, and, where applicable, Slave 1 water source unit capacity must be greater than or equal to Slave 2 water source unit capacity.
- Be sure to insulate all refrigerant system piping and piping connections.

# REFRIGERANT PIPING INSTALLATION



## Pipe Sizing for ARWN Series Heat Pump Systems

The following is an example of manual pipe size calculations. Designers are highly encouraged to use LATS instead of manual calculations.

### Combination Y-branch Pipe and Header Pipe Sizing When Installing a Dual-Frame System

#### Example: Five (5) indoor units connected

- WSU: Water Source Unit.
- IDU: Indoor units.
- A: Main Pipe from Water Source Unit to First Y-branch.
- B: Heat Recovery Unit to Heat Recovery Unit, Y-branch to Heat Recovery Unit, Heat Recovery Unit to Header, or Y-branch to Y-branch.
- C: Heat Recovery Unit or Header to Indoor Unit.

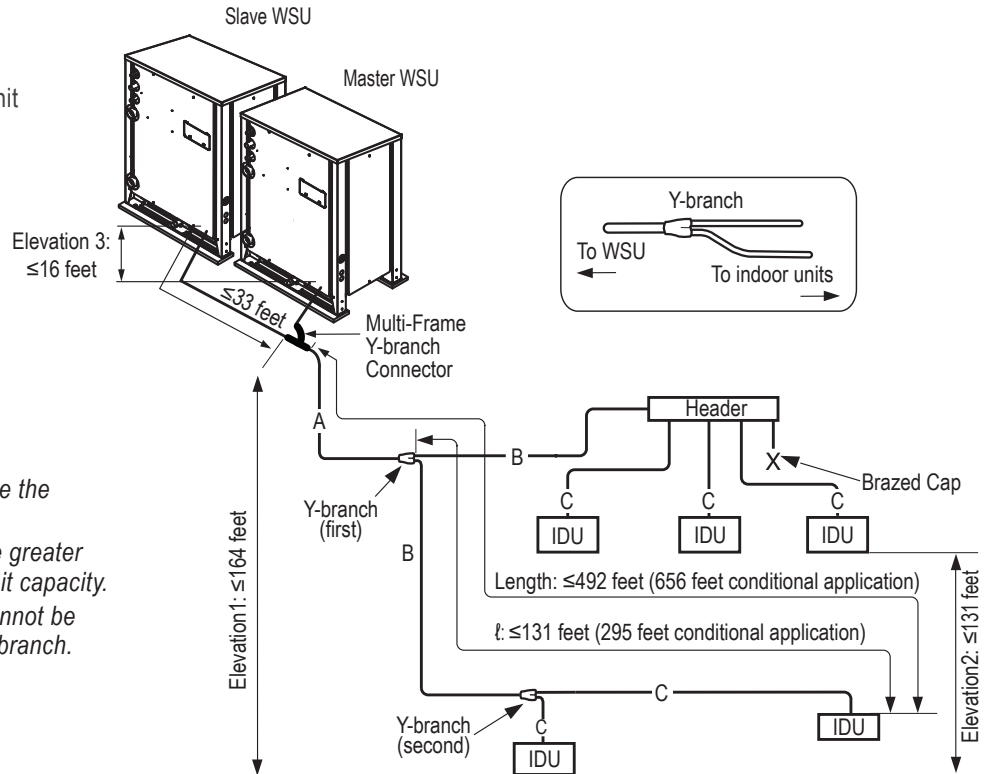

#### Note:

- Larger-capacity water source units must be the master in a multi-frame system.
- Master water source unit capacity must be greater than or equal to the slave water source unit capacity.
- Y-branches and other header branches cannot be installed downstream of the initial header branch.

Table 48: Main Pipe (A) Diameter from Water source Unit to First Y-branch / Header Branch.

WSU Capacity (ton)	Pipe diameter when equivalent pipe length from WSU to farthest IDU is <295 ft.		Pipe diameter when equivalent pipe length from WSU to farthest IDU is ≥295 feet	
	Liquid pipe (inches OD)	Vapor pipe (inches OD)	Liquid pipe (inches OD)	Vapor pipe (inches OD)
6	3/8	3/4	1/2	7/8
8	3/8	7/8	1/2	1
10	1/2	1-1/8	5/8	1-1/8
12	1/2	1-1/8	5/8	1-1/8
14	1/2	1-1/8	5/8	1-3/8
16	1/2	1-1/8	5/8	1-3/8
18	3/4	1-3/8	7/8	1-5/8
20	3/4	1-3/8	7/8	1-5/8
24	3/4	1-3/8	7/8	1-5/8
28	3/4	1-5/8	7/8	1-5/8
30	3/4	1-5/8	7/8	1-5/8
32	3/4	1-5/8	7/8	1-5/8
34	3/4	1-5/8	7/8	1-5/8
36	3/4	1-5/8	7/8	1-5/8
40	3/4	1-5/8	7/8	1-5/8
48	3/4	1-5/8	7/8	1-5/8

Table 49: Refrigerant Pipe (B) Diameter from Y-branch to Y-branch / Header.

Downstream Total Capacity of IDUs (Btu/h) <sup>1</sup>	Liquid pipe (inches OD)	Vapor pipe (inches OD)
≤19,100	1/4	1/2
≤54,600	3/8	5/8
≤76,400	3/8	3/4
≤112,600	3/8	7/8
≤160,400	1/2	1-1/8
≤242,300	5/8	1-1/8
≤354,900	3/4	1-3/8
≤354,900	3/4	1-5/8

<sup>1</sup>For first branch pipe, use branch pipe that matches main pipe A diameter.

Table 50: IDU Connecting Pipe (C) from Y-Branch.

Indoor Unit Capacity <sup>1</sup>	Liquid pipe (inches OD)	Vapor pipe (inches OD)
≤19,100	1/4	1/2
≤54,600	3/8	5/8
≤76,400	3/8	3/4

<sup>1</sup>9,600-24,200 Btu/h 4-way 3 feet x 3 feet Cassette and 15,400-24,200 Btu/h High Static Ducted indoor units have 3/8Ø (liquid) and 5/8Ø (vapor).



The following is an example of manual pipe size calculations. Designers are highly encouraged to use LATS instead of manual calculations.

Table 51: Pipe Capabilities.

Length:	Total pipe length Longest actual pipe length Equivalent pipe length <sup>1</sup>	$A + \Sigma B + \Sigma C \leq 1,640$ feet $\leq 656$ feet $\leq 738$ feet
ℓ:	Longest pipe length after first branch	$\leq 131$ feet (295 feet conditional application)
Elevation 1:	Elevation differential (Water Source Unit ↔ Indoor Unit)	Height $\leq 164$ feet
Elevation 2:	Elevation differential (Indoor Unit ↔ Indoor Unit)	Height $\leq 131$ feet
Elevation 3:	Elevation differential (Highest Water Source Unit ↔ Lowest Water Source Unit)	Height $\leq 16$ feet
	Distance between WSU to WSU	$\leq 33$ feet
	Distance between fittings and IDU	$\geq 20$ inches
	Distance between fittings and Y-branches / Headers	$\geq 20$ inches
	Distance between two Y-branches / Headers	$\geq 20$ inches

<sup>1</sup>For calculation purposes, assume equivalent pipe length of Y branches to be 1.6 feet, and the equivalent pipe length of headers to be 3.3 feet.

**Note:**

- Connection piping from branch to branch cannot exceed the main pipe diameter (A) used by the water source unit.
- Y-branches and other header branches cannot be installed downstream of the initial header branch.
- Install the header branch so that the pipe distances between the connected indoor units are minimized. Large differences in pipe distances can cause indoor unit performances to fluctuate.
- Always reference the LATS Multi V software report.

### Conditional Applications

Conditional applications are computed in LATS. See below for an explanation of when pipes are upsized.

If the equivalent length between the first Y-branch to the farthest indoor unit is  $>131$  feet (up to 295 feet maximum):

- Pipe segment diameters between the first Y-branch and the second Y-branch should be sized up by one following the information in Table 42. This applies to both liquid and vapor pipes. If the next size up is not available, or if the piping segment diameters are the same as main pipe (A) diameters, sizing up is not possible.
- While calculating the entire refrigerant pipe length, pipe lengths for  $\Sigma B$  should be multiplied by two:  $A + (\Sigma B \times 2) + \Sigma C \leq 1,640$  feet.
- Length of pipe (C) from each indoor unit to the closest Y-branch or header  $\leq 131$  ft.
- $[\text{Length of pipe from water source unit to farthest indoor unit } (A+B+C)] - [\text{Length of pipe from water source unit to closest indoor unit } (A+B+C)] \leq 131$  feet.

If the pipe (B) diameters after the first branch are bigger than the main pipe (A) diameters, pipe (B) should be changed to match main pipe (A) sizes.

Example: When an indoor unit combination ratio of 120% is connected to a 22-ton water source unit:

Water source unit main pipe (A) diameters: 1-3/8Ø inches (vapor) and 5/8Ø inches (liquid).

1. Pipe (B) diameters: 1-3/8Ø (vapor) and 3/4Ø (liquid) (after the first branch, when indoor unit combination ratio is 120% [26 tons]).
2. After the first branch, pipe (B) diameters must be changed to 1-3/8Ø inches (vapor) and 5/8Ø inches (liquid) to match main pipe (A) sizes.

Instead of using the total indoor unit capacity to choose main pipe (A) diameters, use water source unit capacity to choose downstream main pipe (A) diameters. Do not permit connection pipes (B) from branch to branch to exceed main pipe (A) diameters as indicated by water source unit capacity. Example: When an indoor unit combination ratio of 120% is connected to a 20-ton water source unit (24 tons), and indoor unit with a 7,000 Btu/h capacity is located at the first branch:

1. Main pipe (A) diameters on a 20-ton water source unit: 1-1/8Ø inches (vapor) and 5/8Ø inches (liquid).
2. Pipe diameters between first and second branches, however, are: 1-3/8Ø (vapor) and 3/4Ø (liquid) (connected downstream indoor unit capacity is 20 tons).
3. If main pipe (A) diameters of a 20-ton water source unit are 1-1/8Ø (vapor) and 5/8Ø (liquid), then the pipe diameters between the first and second branches should be changed to match.

# REFRIGERANT PIPING INSTALLATION



## Pipe Sizing for ARWB Series Heat Recovery Systems

### Triple-Frame Heat Recovery Water Source Unit Connections

Figure 37: Heat Recovery Triple-Frame Refrigerant Pipe Connections.

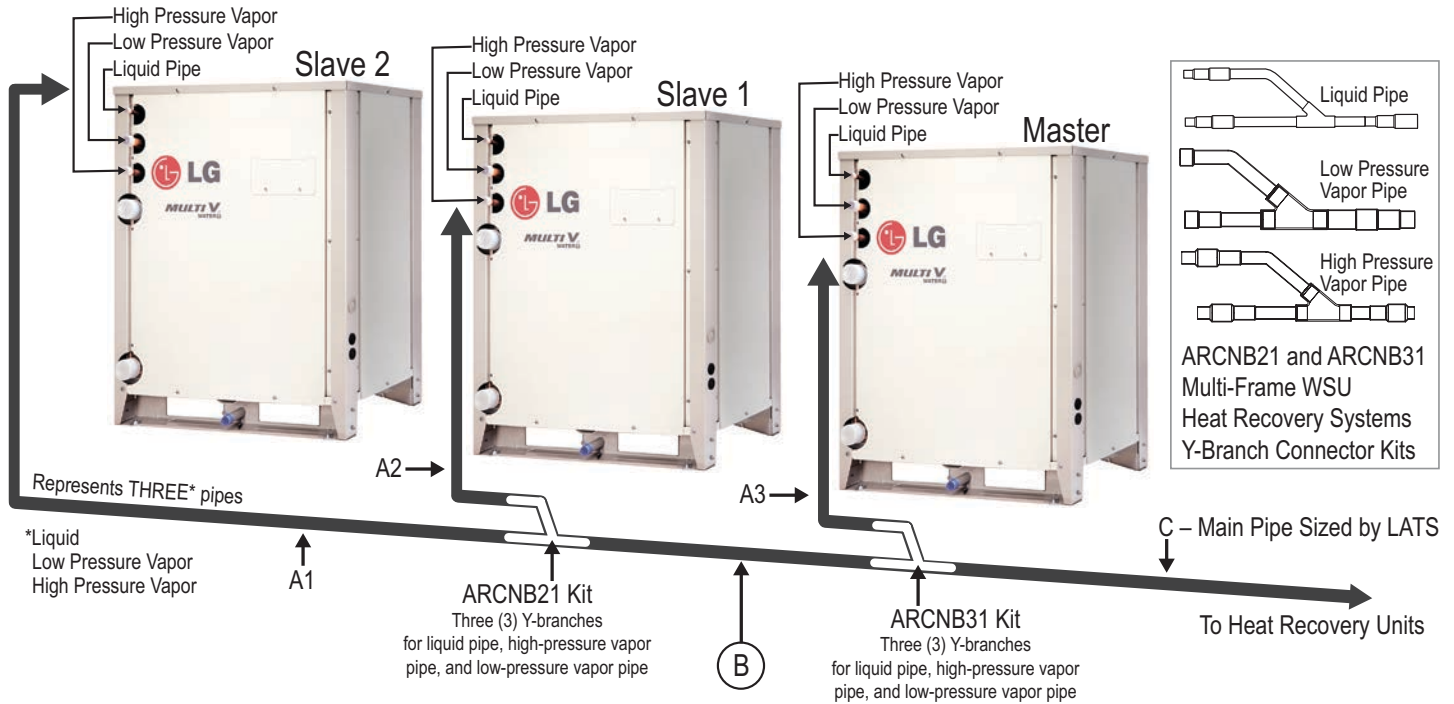

### Refrigerant Pipe Sizes for WSU Connections

- Figure 36 is for reference only, is not to scale, and does not represent required pipe routing.
- Multi-frame Y-branches MUST be installed horizontally as shown in Figure 22.
- A1, A2, and A3 pipe diameters match the water source unit connection diameters.
- Main pipe C diameters are sized by LATS.
- See Table 52 for B pipe diameters.

Table 52: Heat Recovery Triple-Frame Connection Pipe Sizes.

WSU System Size (tons)	WSU System Model	Master WSU Frame	Slave 1 WSU Frame	Slave 2 WSU Frame	B Pipe (in. OD) If Equivalent Pipe Length from WSU to Farthest IDU is <295 ft.			B Pipe (in. OD) If Equivalent Pipe Length from WSU to Farthest IDU is ≥295 ft.		
					Liquid	Low Pressure Vapor	High Pressure Vapor	Liquid	Low Pressure Vapor	High Pressure Vapor
30	ARWB360BAS4	ARWB144BAS4	ARWB144BAS4	ARWB072BAS4	3/4	1-3/8	1-1/8	7/8	1-5/8	1-1/8
36	ARWB432BAS4	ARWB144BAS4	ARWB144BAS4	ARWB144BAS4	3/4	1-3/8	1-1/8	7/8	1-5/8	1-1/8
40	ARWB480DAS4	ARWB192DAS4	ARWB144DAS4	ARWB144DAS4	3/4	1-3/8	1-1/8	7/8	1-5/8	1-1/8
48	ARWB576DAS4	ARWB192DAS4	ARWB192DAS4	ARWB192DAS4	3/4	1-3/8	1-1/8	7/8	1-5/8	1-1/8

### Note:

- Larger-capacity water source units must be the master in a multi-frame system.
- Master water source unit capacity must be greater than or equal to the Slave 1 water source unit capacity, and, where applicable, Slave 1 water source unit capacity must be greater than or equal to Slave 2 water source unit capacity.
- Be sure to insulate all refrigerant system piping and piping connections.



The following is an example of manual pipe size calculations. Designers are highly encouraged to use LATS instead of manual calculations.

### Pipe Sizing When Installing Heat Recovery Units

**Example: Triple-frame system, four (4) heat recovery units, one (1) header, and twelve (12) indoor units connected**

WSU: Water Source Units.

HRU: Heat Recovery Units.

IDU: Indoor units.

A: Main Pipe from Water Source Unit to First Y-branch.

B: Heat Recovery Unit to Heat Recovery Unit, Heat Recovery Unit to Header, or Y-branch to Y-branch.

C: Heat Recovery Unit or Header to Indoor Unit.

**Note:**

- Connection piping from branch to branch cannot exceed main pipe diameter (A) used by WSU.
- Install the header branches or heat recovery units so that the pipe distances between the connected indoor units are minimized. Large differences in pipe distances can cause indoor unit performances to fluctuate.
- Y-branches and other headers branches cannot be installed downstream of initial header branch.
- Total capacity of indoor units in series connection of heat recovery units  $\leq 192,400$  Btu/h.
- Always reference the LATS Multi V software report.

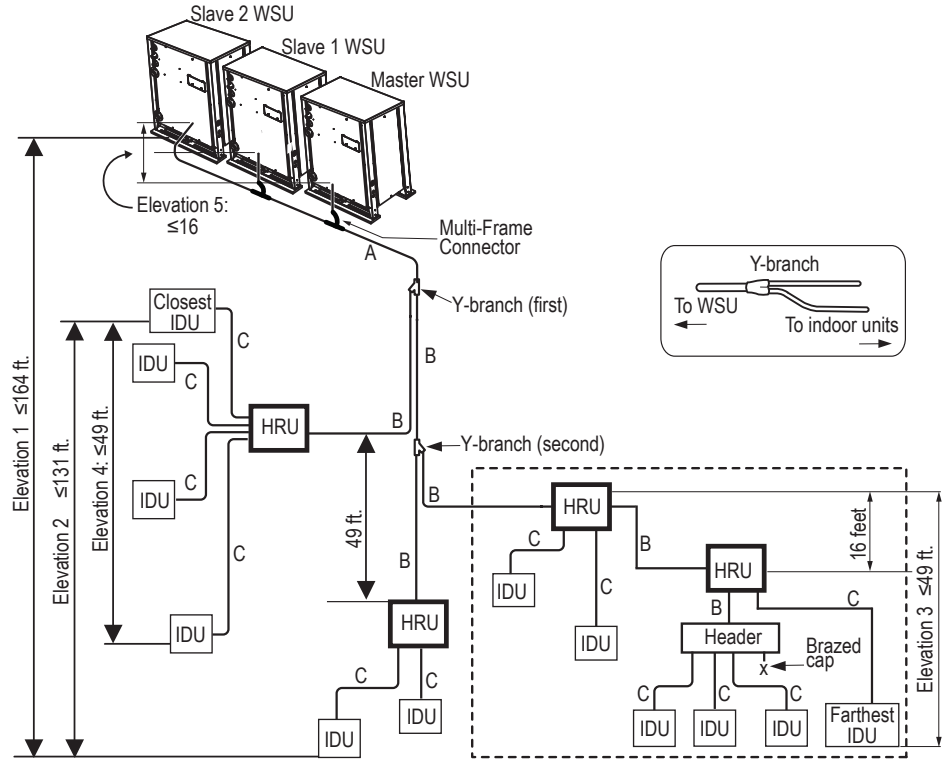

- Larger-capacity water source units must be the master in a multi-frame system.
- Master WSU capacity must be greater than or equal to the slave1 WSU capacity, and, where applicable, slave1 WSU capacity must be greater than or equal to the slave2 WSU capacity.
- Refer to refrigerant pipe diameter and pipe length tables for actual lengths.

Table 53: Main Pipe (A) Diameter from WSU to First Y-branch.

WSU Capacity (ton)	Pipe diameter when equivalent pipe length from WSU to farthest IDU is <295 ft.			Pipe diameter when equivalent pipe length from WSU to farthest IDU is $\geq 295$ ft.		
	Liquid Pipe (inches OD)	Low Pressure Vapor Pipe (inches OD)	High Pressure Vapor Pipe (inches OD)	Liquid Pipe (inches OD)	Low Pressure Vapor Pipe (inches OD)	High Pressure Vapor Pipe (inches OD)
6	3/8	7/8	3/4	1/2	7/8	3/4
8	3/8	7/8	3/4	1/2	1-1/8	3/4
10	1/2	1-1/8	3/4	5/8	1-1/8	3/4
12	1/2	1-1/8	3/4	5/8	1-1/8	3/4
14	1/2	1-1/8	3/4	5/8	1-1/8	3/4
16	1/2	1-1/8	3/4	5/8	1-1/8	3/4
18	3/4	1-3/8	1-1/8	7/8	1-3/8	1-1/8
20	3/4	1-3/8	1-1/8	7/8	1-3/8	1-1/8
22	3/4	1-3/8	1-1/8	7/8	1-3/8	1-1/8
24	3/4	1-3/8	1-1/8	7/8	1-3/8	1-1/8
26	3/4	1-3/8	1-1/8	7/8	1-3/8	1-1/8
28	3/4	1-3/8	1-1/8	7/8	1-3/8	1-1/8
30	3/4	1-5/8	1-3/8	7/8	1-5/8	1-3/8
32	3/4	1-5/8	1-3/8	7/8	1-5/8	1-3/8
34	3/4	1-5/8	1-3/8	7/8	1-5/8	1-3/8
36	3/4	1-5/8	1-3/8	7/8	1-5/8	1-3/8
40	3/4	1-5/8	1-3/8	7/8	1-5/8	1-3/8
48	3/4	1-5/8	1-3/8	7/8	1-5/8	1-3/8

# REFRIGERANT PIPING INSTALLATION



## Pipe Sizing for Heat Recovery ARWB Series

The following is an example of manual pipe size calculations. Designers are highly encouraged to use LATS instead of manual calculations.

Table 54: Refrigerant Pipe (B) Diameter between Y-branches and Y-branches / Heat Recovery Unit / Headers.

Downstream IDU total capacity (Btu/h)	Liquid pipe (in. OD)	Vapor pipe (in. OD)	
		Low pressure	High pressure
≤19,100	1/4	1/2	3/8
<54,600	3/8	5/8	1/2
<76,400	3/8	3/4	5/8
<114,700	3/8	7/8	3/4
<172,000	1/2	1-1/8	7/8
<229,400	5/8	1-1/8	7/8
<248,500	5/8	1-3/8	1-1/8
<344,000	3/4	1-3/8	1-1/8
<592,500	3/4	1-5/8	1-3/8

Table 55: Indoor Unit Connecting Pipe from Branch (C).

Indoor Unit Capacity <sup>1</sup>	Liquid pipe (in. OD)	Vapor pipe (in. OD)
≤19,100	1/4	1/2
≤54,600	3/8	5/8
≤76,400	3/8	3/4

<sup>1</sup>9,600-24,200 Btu/h 4-way 3 feet x 3 feet Cassette and 15,400-24,200 Btu/h High Static Ducted IDUs have 3/8Ø (liquid) and 5/8Ø (vapor).

Table 56: Pipe Capabilities.

Length:	Total pipe length Longest actual pipe length Equivalent pipe length <sup>1</sup>	A + ΣB + ΣC ≤ 1,640 feet ≤656 feet ≤738 feet
ℓ:	Longest pipe length after first branch	≤131 feet (295 feet conditional application)
Elevation 1:	Elevation differential (Water Source Unit ↔ Indoor Unit)	Height ≤164 feet
Elevation 2:	Elevation differential (Indoor Unit ↔ Indoor Unit) [IDUs connected to separate HRUs which are parallel (Y-branch) connected]	Height ≤131 feet
Elevation 3:	Elevation differential (Indoor Unit ↔ Connected HRU or Series Connected HRU)	Height ≤49 feet
Elevation 4:	Elevation differential (Indoor Unit ↔ Indoor Unit [connected to same Heat Recovery Unit])	Height ≤49 feet
Elevation 5:	Elevation differential (Highest WSUnit ↔ Lowest WSU)	Height ≤16 feet
	Distance between WSU to WSU	≤33 feet
	Distance between fittings and IDU	≥20 inches
	Distance between fittings and Y-branches / Headers	≥20 inches
	Distance between two Y-branches / Headers	≥20 inches
	Elevation between two heat recovery units if installed with a Y-branch	≤49 feet
	Height difference between two series-piped heat recovery units	≤16 feet
	Maximum number of heat recovery units per system	16

<sup>1</sup>For calculation purposes, assume equivalent pipe length of Y-branches to be 1.6 feet, and the equivalent pipe length of headers to be 3.3 feet.

## Conditional Applications

Conditional applications are computed in LATS. See below for an explanation of when pipes are upsized.

If the equivalent length between the first Y-branch to the farthest indoor unit is >131 feet (maximum 295 feet):

- Pipe segment diameters between the first branch and the last branch should be sized up by one following the information in Table 49. This applies to both liquid and low / high vapor pipes. If the next size up is not available, or if the pipe segment diameters are the same as main pipe (A) diameters, sizing up is not possible.
- While calculating total refrigerant piping length, pipe (B) segment lengths between the first Y-branch and second Y-branch, and between the second Y-branch and the heat recovery unit should be calculated by two.
- Length of pipe (C) from each indoor unit to the closest Y-branch, header, or heat recovery unit ≤131 feet.
- [Length of pipe from water source unit to farthest indoor unit (A+B+C)] - [Length of pipe from water source unit to closest indoor unit (A+B+C)] ≤131 feet.



### Acceptable Layout Examples

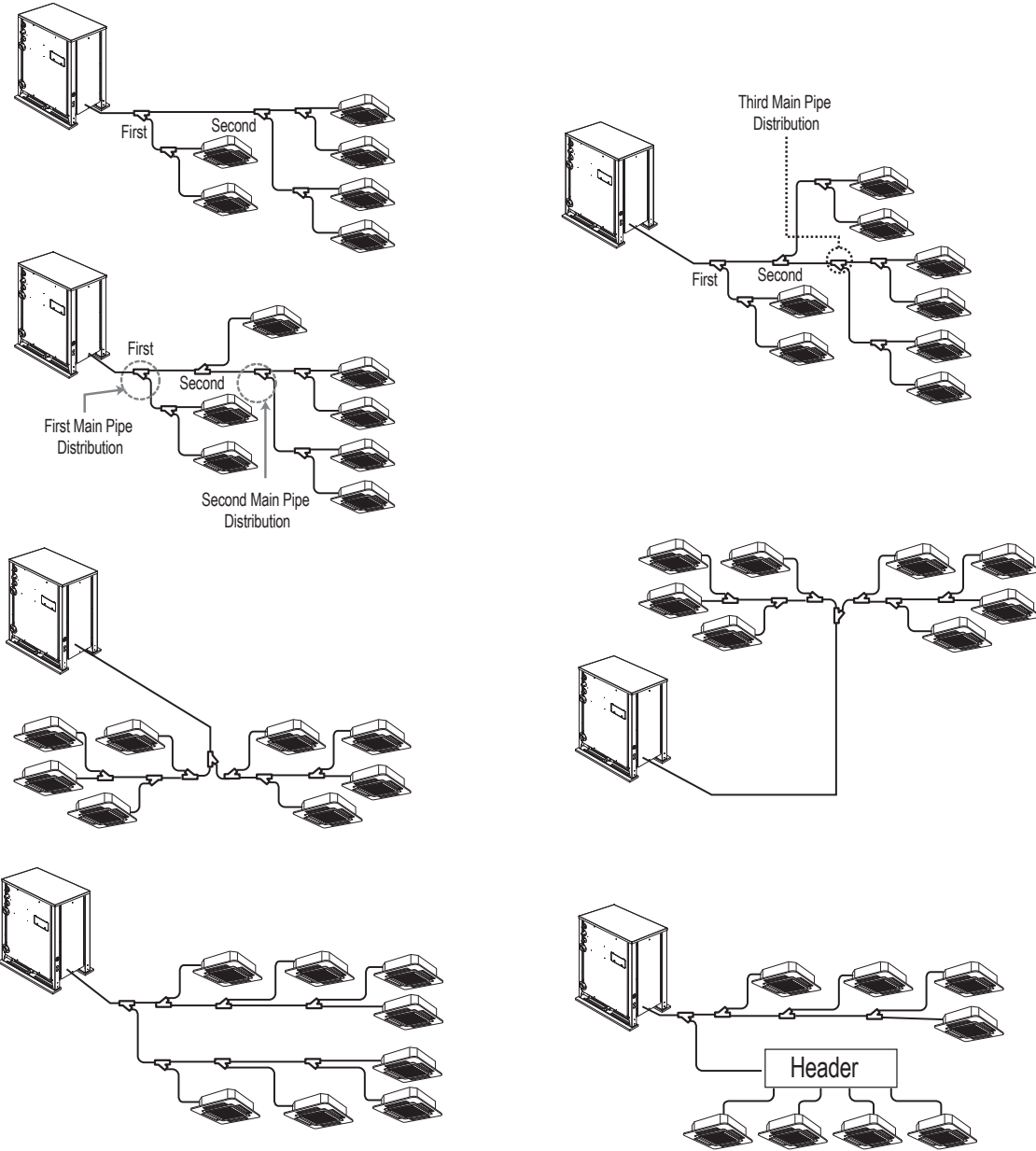

### Unacceptable Piping System Layouts

A second branch cannot be installed after a header.

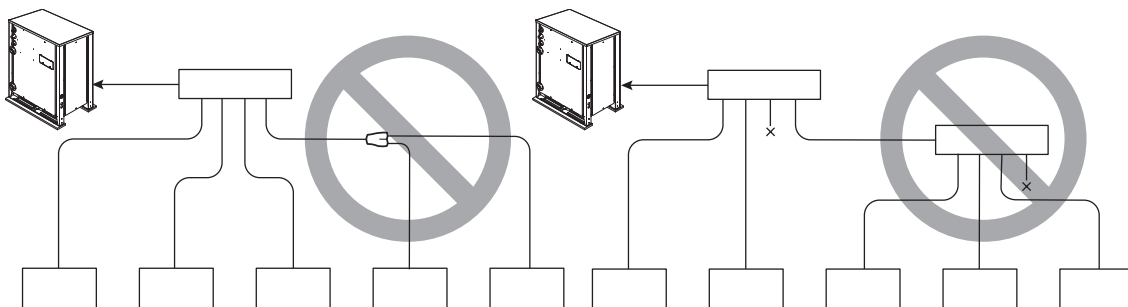

## Pipe Layout

### Refrigerant Piping for Separated Water Source Units

Dual-frame and triple-frame systems should be installed with all water source units located next to each other. In conditions where the dual-frame or triple-frame water source units need to be separated, the following rules must be followed:

1. Measurements.

All measurements should be made from the union center of the water source unit Y-branch.

Figure 39: Y-branch Measurement Location.

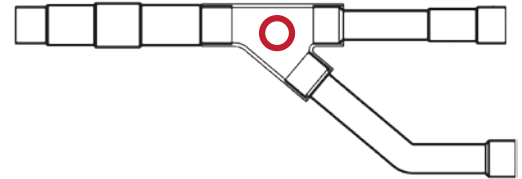

2. Maximum pipe length from first water source unit Y-branch to farthest water source unit.

Total pipe length from the first outdoor unit Y-branch to the piping connection at the farthest outdoor unit must not exceed thirty-three (33) feet.

Figure 40: Maximum Pipe Length from First WSU Y-branch to Farthest WSU.

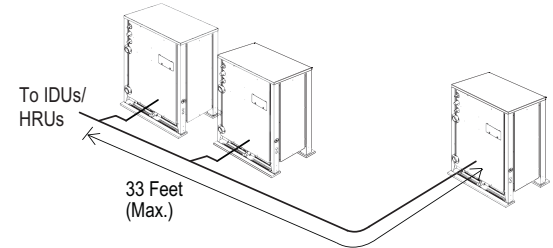

3. Elevation difference between water source units.

The elevation difference between the highest and lowest elevation water source unit must not exceed sixteen (16) feet.

Figure 38: Elevation Difference Between Water Source Units.

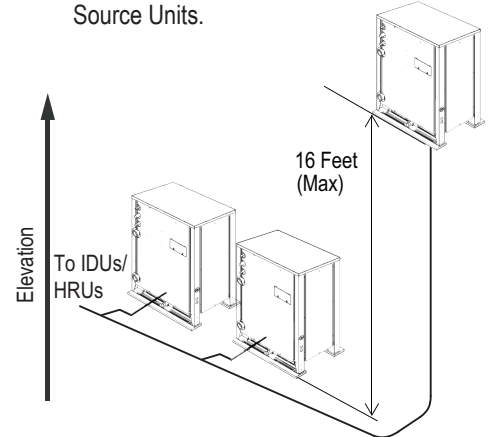

### Trapping

1. When required, all traps must be inverted type traps  $\geq 8"$  in the vapor line(s).

a. Heat pump water source units would be trapped in the suction vapor line, and heat recovery water source units would be trapped in the high AND low pressure vapor lines.

b. Inverted traps are defined as any piping that is  $\geq 8"$  in a vertical direction up the horizontal pipe it elevates from.

Figure 41: Traps for Heat Pump and Heat Recovery Units.

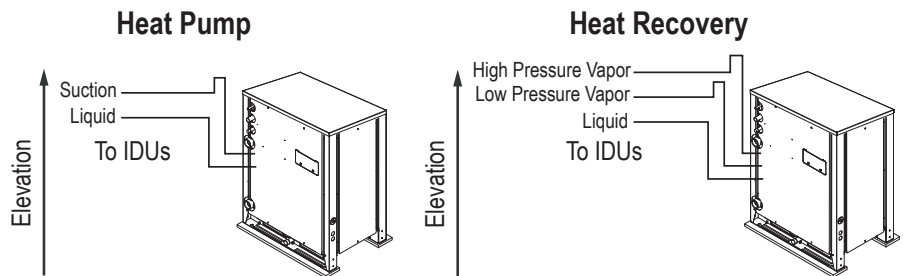

Figure 42: Close Up of An Inverted Oil Trap.



1. Inverted traps are required when:
  - a. Piping in a horizontal direction from the outdoor Y-branch towards an outdoor unit or another outdoor unit Y-branch is greater than 6.6'.

The inverted trap should be installed close to the outdoor unit Y-branch (no more than 6.6' away).

- b. Anytime piping turns downward leaving an outdoor unit Y-branch toward an outdoor unit or another outdoor unit Y-branch.

The inverted trap should be installed close to the outdoor unit Y-branch (no more than 6.6' away), and before the pipe toward the outdoor unit turns downward.

Figure 43: Examples of Inverted Traps.

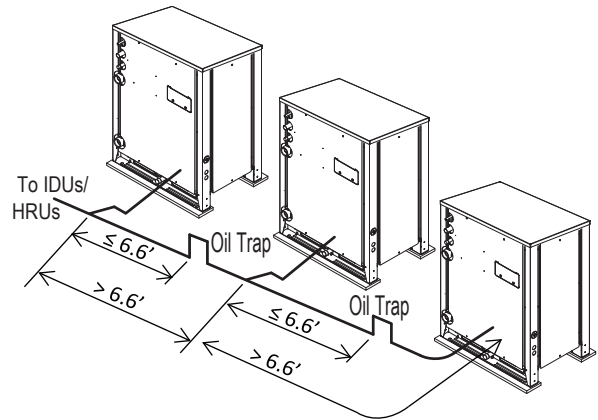
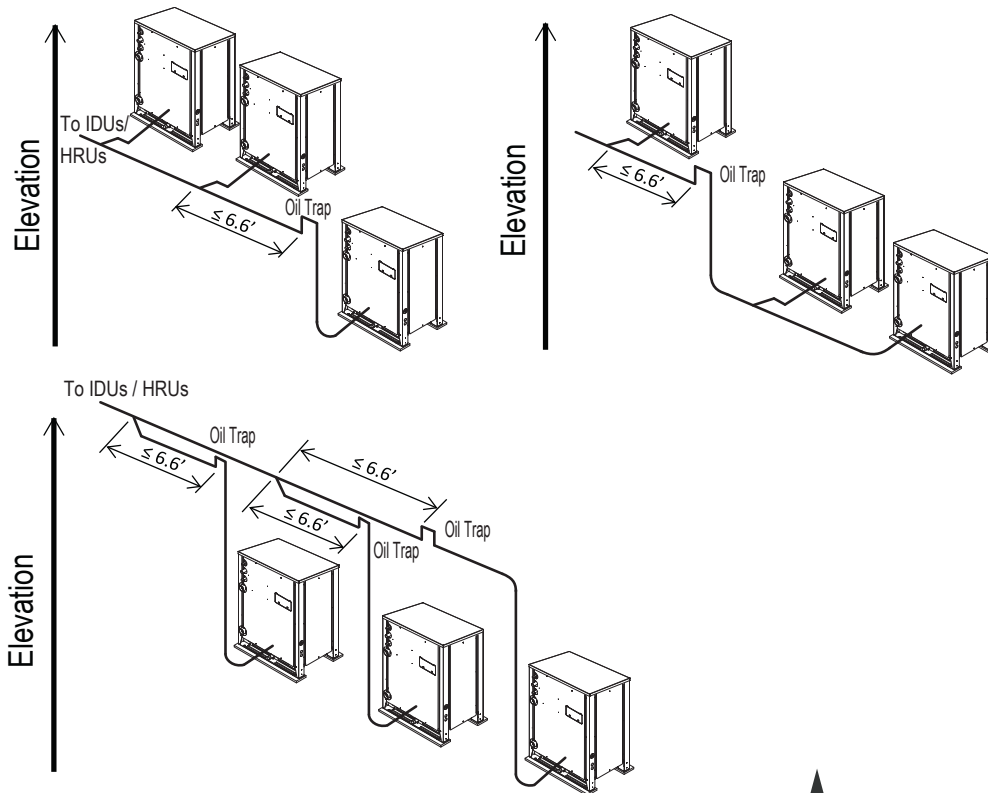

Figure 44: Inverted Trap Applications.



### Pipe Slope

Horizontal pipe slope should be level or slightly away from the water source units, otherwise refrigerant and oil will migrate toward the water source units and accumulate in the pipe segment serving the frame that is not running or at the lowest elevation. Piping should never slope more than  $-10^\circ$  (see figure) without installing an inverted trap within 6.6' of the water source unit Y-branch and before the pipe slopes downward toward the water source unit.

Figure 45: Allowable Pipe Slope.

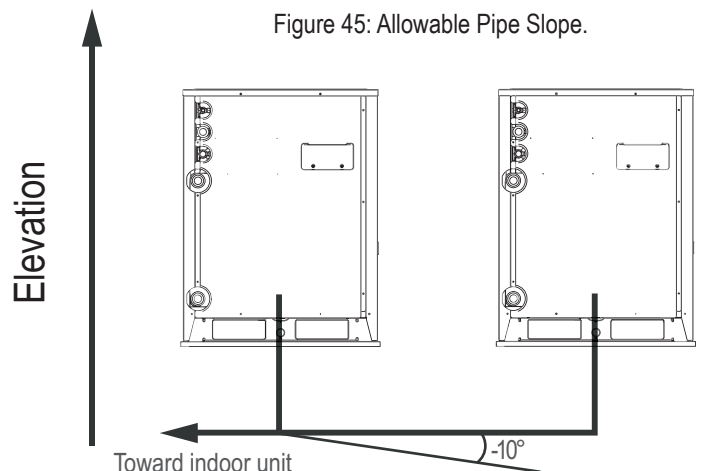

## Refrigerant Pipe Connections

Before connecting the piping:

- Remove the front panel.
- Check all pipes (liquid and vapor).

Figure 46: Water Source Unit Front Panel.

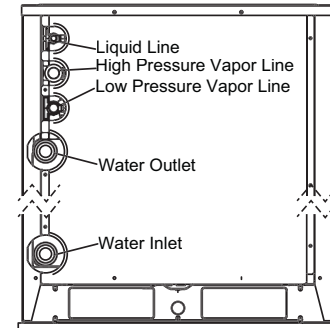

### Water Source Unit Service Valves

- |                              |                     |                              |
|------------------------------|---------------------|------------------------------|
| 1. Field piping.             | 4. Schrader valves. | 7. Field-supplied 90° elbow. |
| 2. Flare nut.                | 5. Liquid pipe.     |                              |
| 3. Ball type service valves. | 6. Vapor pipe.      |                              |

**Note:**

Do not expose the service valves of the water source unit to heat. Protect the service valve with a wet towel during brazing.

### Operating the Service Valves

1. Loosen or tighten the flare nut by using a torque wrench and backup wrench. Coat the flare connection with polyvinyl ether (PVE) refrigeration oil.
2. Remove service valve cap. To operate the shutoff valve, turn ball valve stem 90° using an open-end wrench. Always backseat the valve. After operation, always replace the caps (Tightening torque of service valve cap: = 18.0 lb-ft).
3. Evacuate the system, and then charge the refrigerant using the Schrader valve. Reattach the Schrader valve cap after servicing is complete. (Tightening torque of service cap: =10.0 lb-ft).

Figure 47: Service and Schrader Valve Detail.

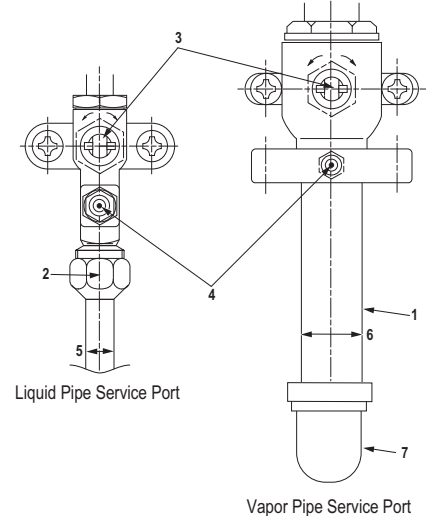

- The unit ships with a factory charge of refrigerant. When connecting and brazing the vapor line, using a wet rag or cooling gel product to protect the service and Schrader valves from excessive heat.
- After connections are complete, verify that the service ports and caps are securely tightened to prevent leaking refrigerant gas.

Figure 48: Service Valves - Open and Closed Positions.

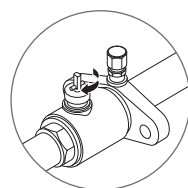

Indicates "open" when the pipe and the "flats" of the valve stem are parallel.

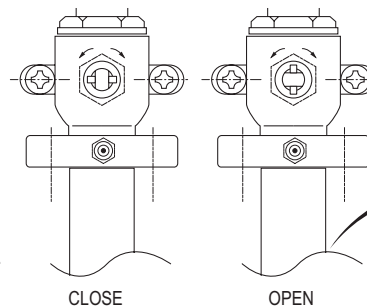

Cut length of pipe and valve as desired, but length must be a minimum of 2-3/4 inches.

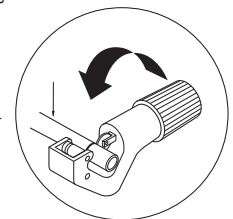

### ⚠ WARNING

- Always take extreme caution to prevent refrigerant gas (R410A) from leaking during use, around fire or flame, and during brazing. If the refrigerant gas comes in contact with a flame from any source, it may break down and generate a poisonous gas. Never braze in a room that is not ventilated. After refrigerant piping work is complete, securely tighten both service and Schrader valves to help prevent refrigerant gas from leaking. Verify the system is free of leaks after refrigerant piping installation is complete.
- Do not attempt to remove service valve stem and packing or Schrader valve core. Physical injury or death may occur from uncontrolled rapid release of refrigerant.

**Note:**

- When connecting the refrigerant piping, make sure the service valves of the water source unit are completely closed (factory setting). Do not open the service valves or attempt to operate the system until the refrigerant pipe system installation has been completed. Never open the valves before a pressure test is performed, the system is evacuated, a leak test performed, and the Commissioning Agent provides authorization to do so.
- Do not use polyolester (POE) or any other type of mineral oil as a thread lubricant. If introduced to the refrigerant circuit, this type of oil will create oil sludge leading to system malfunction.
- Use steel wool or comparable material to fill gaps between the unit case and the refrigerant and electrical connections to prevent rodent and animal entry.

### ⚠ WARNING

- Do not allow the refrigerant to leak during brazing; if the refrigerant combusts, it generates a toxic gas.
- Do not braze in an enclosed location
- Always test for gas leaks before / after brazing.

### Water Source Unit Pipe Connections

1. Do not use kinked pipe caused by excessive bending in one specific area on its length.
2. Braze the pipes to the service valve pipe stub of the water source unit.
3. After brazing, check for refrigerant gas leaks.
4. When selecting flare fittings, always use a 45° fitting rated for use with high pressure refrigerant R410A. Selected fittings must also comply with local, state, or federal standards.

### Creating a Flare Fitting

One of the main causes of refrigerant leaks is defective flared connections. Create flared connections using the procedure below.

#### 1. Cut the pipe to length.

- Measure the distance between the indoor unit and the water source unit.
- Cut the pipes a little longer than measured distance.

#### 2A. Remove the burrs.

- Completely remove all burrs from pipe ends.
- When removing burrs, point the end of the copper pipe down to avoid introducing foreign materials in the pipe.

#### 2B. Slide the flare nut onto the copper tube.

#### 3. Flaring the pipe end.

- Use the proper size flaring tool to finish flared connections as shown.
- ALWAYS create a 45° flare when working with R410A.

#### 4. Carefully inspect the flared pipe end.

- Compare the geometry with the figure to the right and dimensions as detailed in Figure 32.
- If the flare is defective, cut it off and re-do procedure.
- If flare looks good, blow the pipe clean with dry nitrogen.

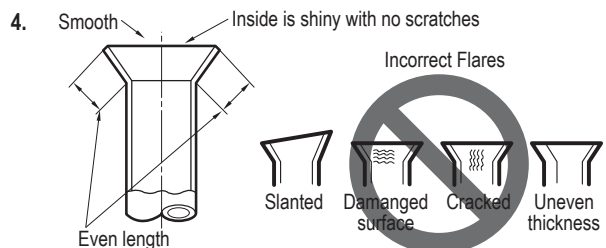
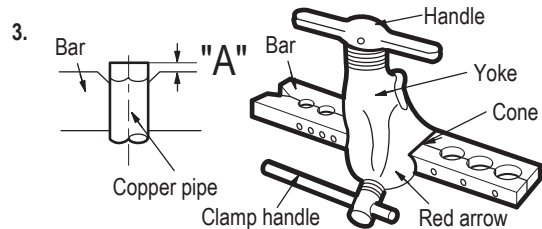
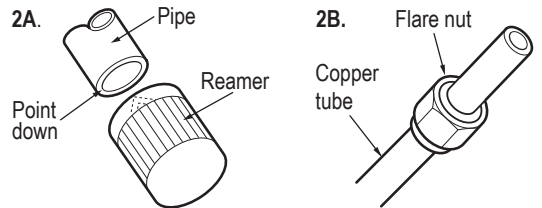
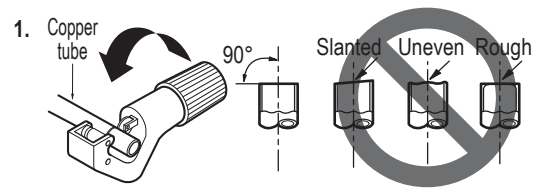

Figure 49: Dimensions of the Flare.

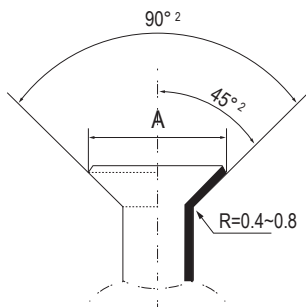

Table 57: Flared Connection Dimensions.

Indoor unit (Btu/h)	Pipe		"A"	
	Vapor (in. O.D.)	Liquid (in. O.D.)	Vapor (in.)	Liquid (in.)
≤19,100	1/2	1/4	5/8 ~ 11/16	7/16 ~ 1/2
<54,600	5/8	3/8	5/8 ~ 11/16	5/8 ~ 11/16
≤76,400	3/4	3/8	3/4 ~ 13/16	5/8 ~ 11/16

# REFRIGERANT PIPING INSTALLATION



## Refrigerant Pipe Connections / Insulating the Refrigerant Piping

### Tightening the Flare Nuts

Table 58: Tightening Torque for Flare Nuts.

Pipe size (Inches O.D.)	Tightening torque (ft-lbs)	Width of the flare (A [inches])
3/8Ø	24.1 - 29.4	1/2
1/2Ø	36.5 - 44.5	5/8
5/8Ø	45.5 - 55.6	3/4

Figure 50: Tightening the Flare Nuts.

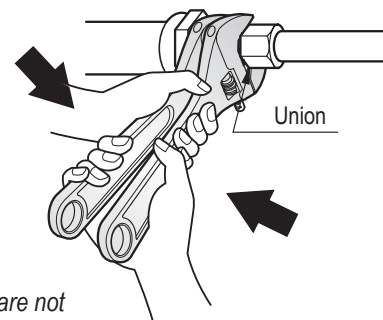

**Note:**

Do not use polyolester (POE) or any other type of mineral oil as a thread lubricant. These lubricants are not compatible with PVE oil used in this system and create oil sludge leading to equipment damage and system malfunction.

1. When connecting the flare nuts, coat the flare (inside and outside) with polyvinyl ether (PVE) refrigeration oil only.
2. Initially hand tighten the flare nuts using three (3) or four (4) turns.
3. To finish tightening the flare nuts, use both a torque wrench and a backup wrench.
4. After all the piping has been connected and the caps have been tightened, check for refrigerant gas leaks.

### Loosening the Flare Nuts

Always use two (2) wrenches to loosen the flare nuts.

### Refrigerant Piping System Insulation

To prevent heat loss/heat gain through the refrigerant piping, all refrigerant piping including liquid lines and vapor lines must be insulated separately. Insulation must be a minimum 1/2" thick, and thickness may need to be increased based on ambient conditions and local codes. All refrigerant piping including Y-branch and Header connections, field-provided isolation ball valves, service valves, and elbows must be completely insulated using closed-cell pipe insulation. All insulation joints must be glued with no air gaps. Insulation material must fit snugly against the refrigeration pipe with no air space between it and the pipe. Insulation passing through pipe hangers, inside conduit, and/or sleeves must not be compressed. Protect insulation inside hangers and supports with a second layer. All pipe insulation exposed to direct sunlight and deterioration-producing elements must be properly protected with a PVC-aluminum vapor barrier jacket, or alternatively placed in a weather-resistant enclosure such as a pipe rack with a top cover. The design engineer should perform calculations to determine if the factory-supplied insulation jackets have sufficient thickness to meet local codes and to avoid sweating at jobsite conditions. Maximum refrigerant pipe temperature is 158°F; minimum refrigerant pipe temperature is -48°F. Add additional insulation if necessary.

Figure 51: Typical Pipe Insulation, Power Wire and Communications Cable Arrangement.

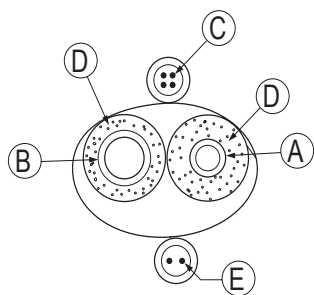

- (A) Liquid Pipe
- (B) Gas Pipe
- (C) Power Wiring
- (D) Insulation
- (E) Communication Cables

Figure 52: Typical Insulation Butt-Joint at Indoor Unit Casing.

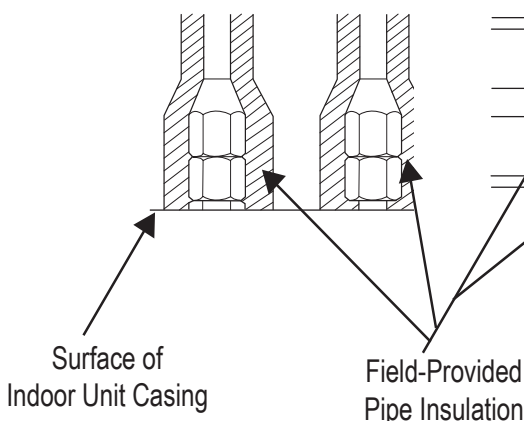
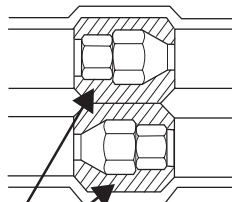

Figure 53: Typical Refrigerant Flare Fitting Insulation Detail.



**Note:**

Always properly insulate the piping. Insufficient insulation will result in condensation, reduced heating/cooling performance, etc. Also, if the pipes aren't insulated properly, condensation could potentially cause damage to building finishes. Pay special attention to insulating the pipes installed in the ceiling plenum.

**Note:**

Follow locals codes and the designer's instructions when selecting EPDM insulation wall thickness.

Table 59: Minimum Refrigerant Pipe EPDM Insulation Wall Thickness Requirements.<sup>1</sup>

Classification	Piping (in. OD)	Air-Conditioned Location		Non-Air Conditioned Location	
		1. Typical Conditioned Location	2. Special Conditioned Location	3. Typical Unconditioned Location	4. Special Unconditioned Location
Liquid pipe	1/4	>1/2 inches	>1/2 inches	>1/2 inches	>1/2 inches
	3/8	>1/2 inches	>1/2 inches	>1/2 inches	>1/2 inches
	≥1/2	>1/2 inches	>1/2 inches	>1/2 inches	>1/2 inches
Vapor pipe	3/8	>1/2 inches	>3/4 inches	>3/4 inches	>1 inch
	1/2				
	5/8				
	3/4				
	7/8				
	1	>3/4 inches	>1 inch	>1 inch	
	1-1/8				
	1-1/4				
	1-3/8				
	1-1/2				
1-3/4					

<sup>1</sup>The thickness of the above insulation material is based on heat conductivity of 0.61 Btu/in/h/ft<sup>2</sup>/°F.

**1. Typical Conditioned Location**

A building plenum or space that contains conditioned air that does not exceed 80°F DB.

**2. Special Conditioned Location**

1. When the location is air conditioned, but there is severe temperature/humidity difference due to high ceilings
  - Church, auditorium, theater, lobby, etc.
2. When the location is air conditioned, but internal temperature/humidity are high
  - Bathroom, swimming pool, locker room, etc.

**3. Typical Unconditioned Location**

An unconditioned space inside a building.

**4. Special Unconditioned Location: If conditions 1 and 2 below are present.**

1. An unconditioned space or plenum of a building.
2. An area where there is an elevated humidity level.

**5. Additional Insulation for Indoor Units May be Required in Humid Environments.**

The air conditioner factory insulation has been tested according to "ISO Conditions with Mist," and it satisfies the requirements. If the system has been operating for a long time in a high humidity environment (dew point temperature: more than 73°F), condensate is likely to form. If this happens, install 3/8 inch thick ethylene propylene diene methylene (EPDM) insulation that is plenum-rated with a heat-resistance factor of more than 158°F.

## Insulating the Refrigerant Piping

### Applying Insulation to Y-Branch and Header Fittings

Check the fit of the insulation jacket provided with the LG Y-branch and Header kits after all pipes are brazed to fittings. Mark all pipes at the point where the insulation jacket ends. Remove the jacket. Install field-supplied insulation on the pipe segments first, and then install the LG provided insulation plugs on the ends of all unused Header ports. Apply the clam-shell insulation on jackets to Y-branch and Header fittings last. Peel the adhesive glue protector slip from the insulation jacket and install the clam-shell jacket over the fitting.

Figure 56: Y-Branch Insulation.

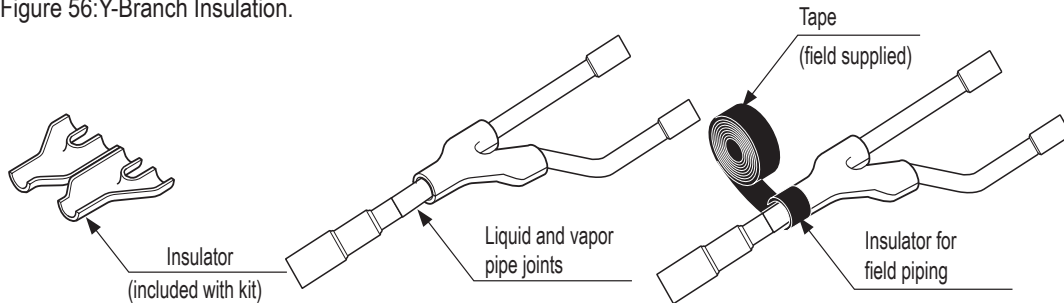

Figure 57: Header Insulation.

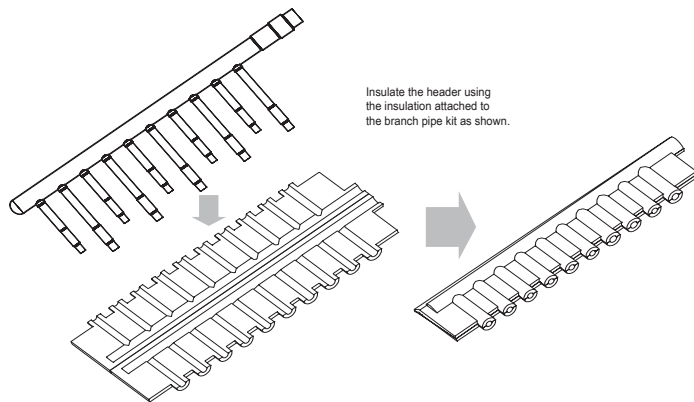

Figure 54: Joints between branch and pipe should be sealed with tape included in each kit.

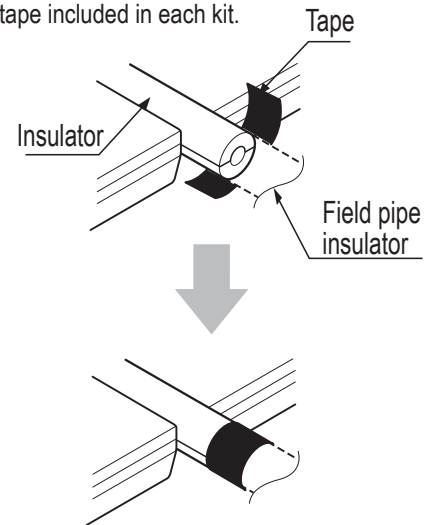
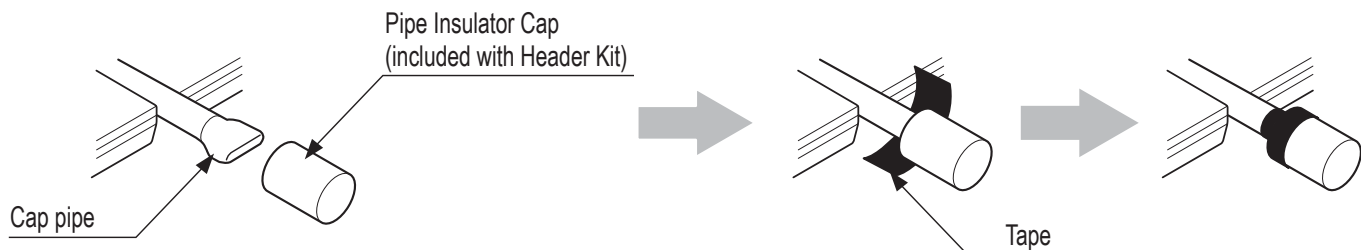

Figure 55: Cap pipes should be insulated using the insulator included in each kit, and then taped as shown.



**Note:**

**Additional Insulation for Y-Branched and Headers May be Required in Humid Environments.**

If the system has been operating for a long time in a high humidity environment (dew point temperature: more than 73°F), condensate is likely to form. If this happens, install 3/8 inch thick ethylene propylene diene methylene (EPDM) insulation that is plenum-rated with a heat-resistance factor of more than 248°F.



### Perform a Pressure (Leak) Test

**Note:**

Do not apply power during this test. If power has been applied to any device before the pressure test, contact your LG Applied Rep champion or service technician for the procedure to reopen the EEV valves.

1. Upon completion of refrigerant piping system installation, open all isolation ball valves throughout the piping system.
2. DO NOT apply power to the Water Source and Indoor Units. If power is applied, expansion valves close and the pressure test will not be conclusive.
3. DO NOT open the water source unit service valves; the factory refrigerant charge will be released.
4. Use medical grade dry nitrogen and pressure test the refrigerant piping system to a minimum of 550 psi for a period of 24 hours. Pressurize the liquid, low pressure vapor, and high pressure vapor (heat recovery systems only) concurrently.

### Heat Pump Pressure Test

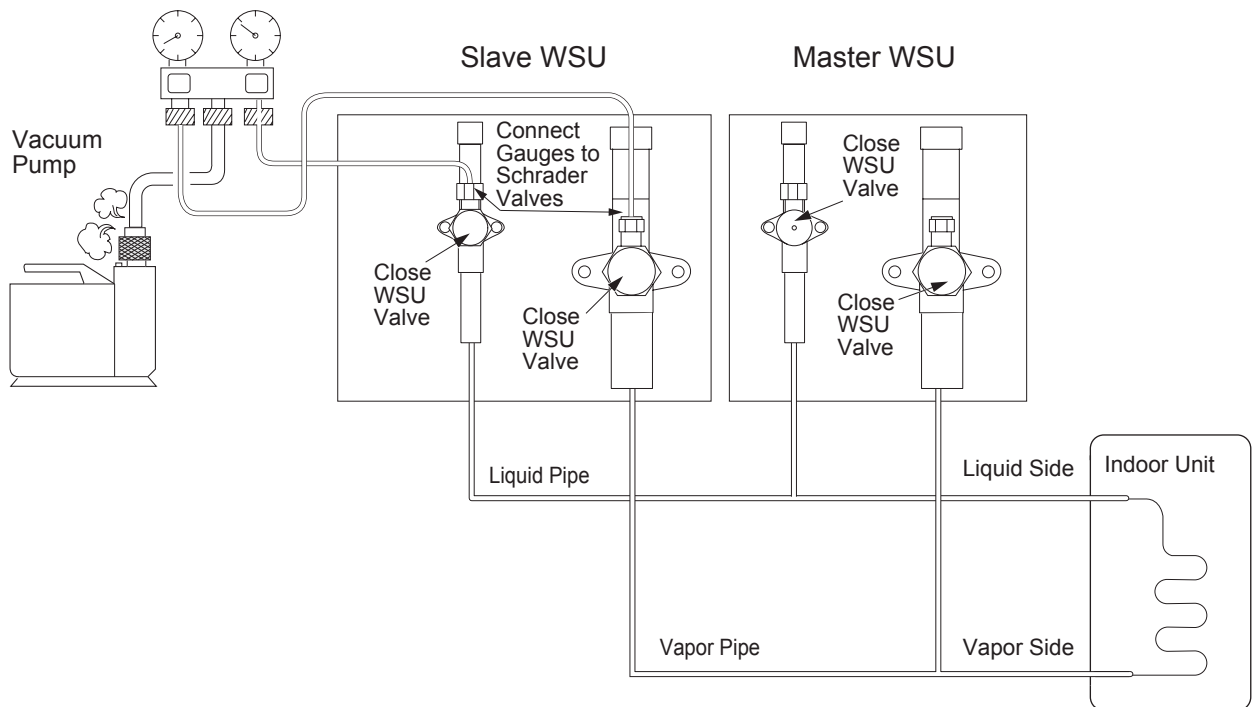

**⚠ WARNING**

During pressurization, the nitrogen gas cylinder must be positioned vertically to prevent the nitrogen from entering the refrigeration system in its liquid state. Do not position the nitrogen cylinder on its side.

**Note:**

If the ambient temperature changes between the time when pressure was applied and when the pressure drop is checked, adjust results by factoring in approximately 1.45 psi for each 2°F of temperature difference.

Correction formula = (Temperature when pressure was applied – Temperature when pressure drop is checked) x 0.01.

Example: When pressure (550 psig) was applied, ambient temperature was 80.6°F; 24 hours later when pressure drop (540 psi) was checked, ambient temperature is 68°F. Thus, (80.6 - 68) x 0.01 = 0.126. In this case, the pressure drop of 0.126 is due to temperature difference; therefore, there is no leak in the refrigerant piping system.

# REFRIGERANT PIPING INSTALLATION



## Pressure (Leak) Testing

### Heat Recovery Pressure Test

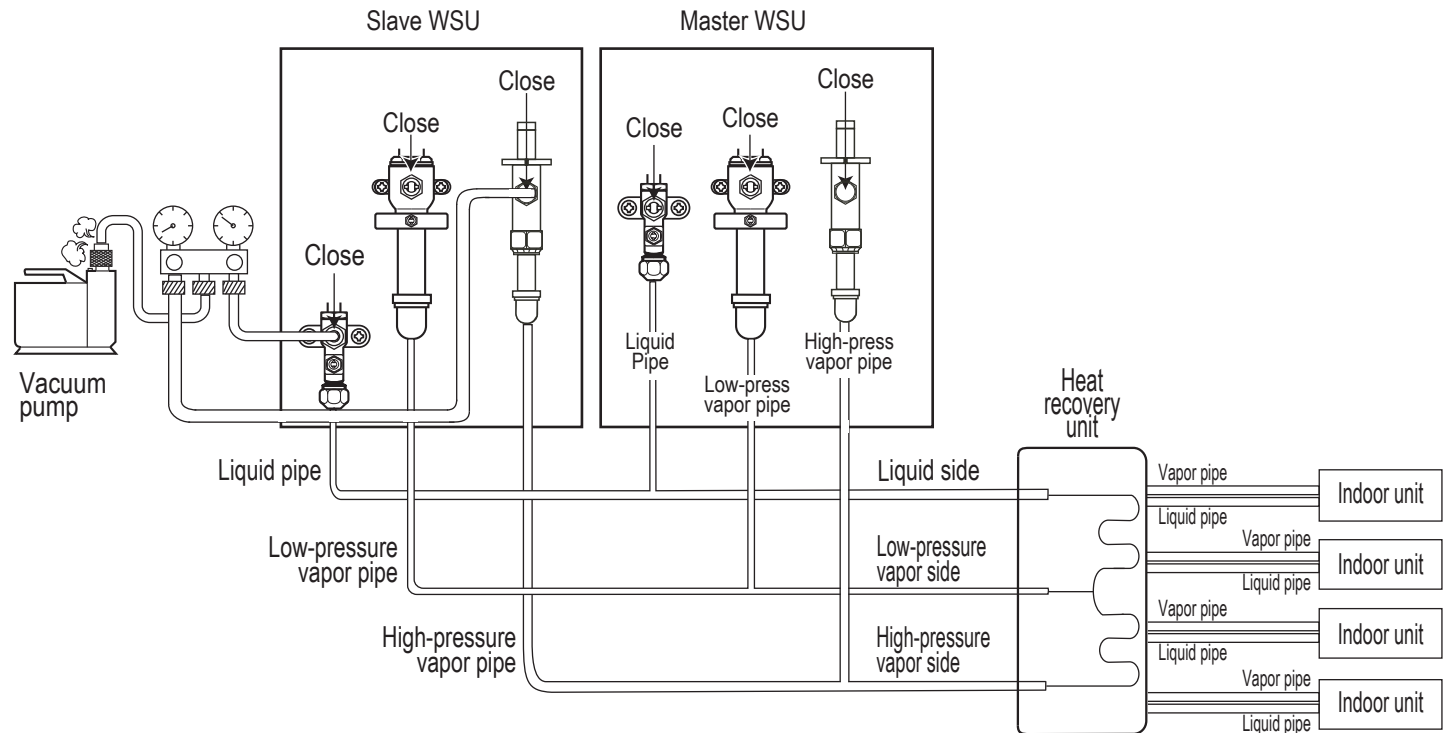

### ⚠ WARNING

During pressurization, the nitrogen gas cylinder must be positioned vertically to prevent the nitrogen from entering the refrigeration system in its liquid state. Do not position the nitrogen cylinder on its side.

### Note:

If the ambient temperature changes between the time when pressure was applied and when the pressure drop is checked, adjust results by factoring in approximately 1.45 psi for each 2°F of temperature difference.

Correction formula = (Temperature when pressure was applied – Temperature when pressure drop is checked) x 0.01.

Example: When pressure (550 psig) was applied, ambient temperature was 80.6°F; 24 hours later when pressure drop (540 psi) is checked, ambient temperature is 68°F. Thus,  $(80.6 - 68) \times 0.01 = 0.126$ . In this case, the pressure drop of 0.126 is due to temperature difference; therefore, there is no leak in the refrigerant piping system.

### Design Steps

The Multi V Water IV Water Source Unit requires a water cooling / heating source. This year-round heating and cooling system has a two (2) pipe closed loop, continuously-circulating water circuit. This water circuit helps maintain water temperature at 23°F to 113°F for cooling mode and 23°F to 113°F for heating mode. Refer to the capacity tables in the Multi V Water IV Water Source Unit Engineering Manual for performance at different entering water temperatures. At the high end of this temperature range, heat is rejected through a cooling tower (dry cooler or geothermal well), while at the low end of the temperature range an auxiliary heat source like a boiler, solar panel, or geothermal well adds heat.

Piping, pumps, and accessories must be sized to provide adequate water flow to the water source unit based on nominal flow rates listed for each model number.

### Design Schematic

Multi V Water IV Water Source Units have factory installed stainless steel plate heat exchangers. To protect these heat exchangers, using closed cooling towers is recommended. If open cooling towers or other open loop systems are used, add an intermediate heat exchanger to protect the water source unit from contaminants and debris that may foul or clog the heat exchanger. Open loop systems without an intermediate heat exchanger are not recommended due to risk of freezing, reduction of flow due to scaling or clogging, or other potential problems caused by improper water quality.

Figure 58: Cooling Cycle Diagram.

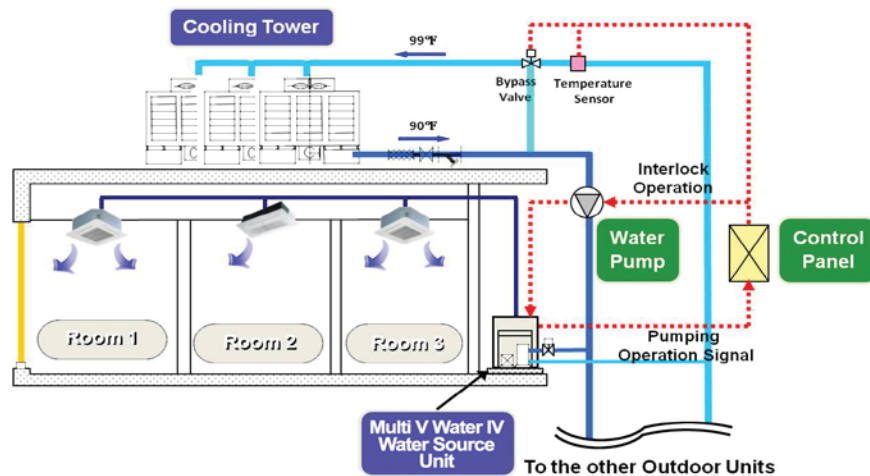

Figure 59: Heating Cycle Diagram.

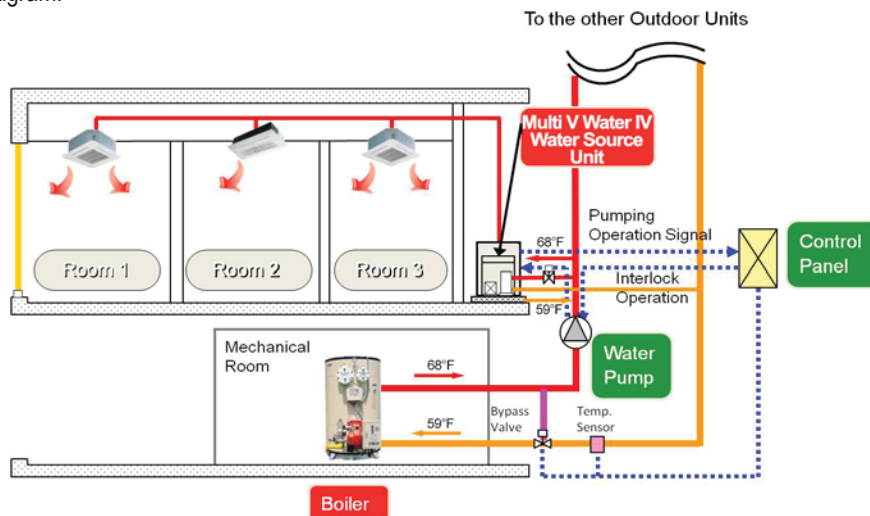
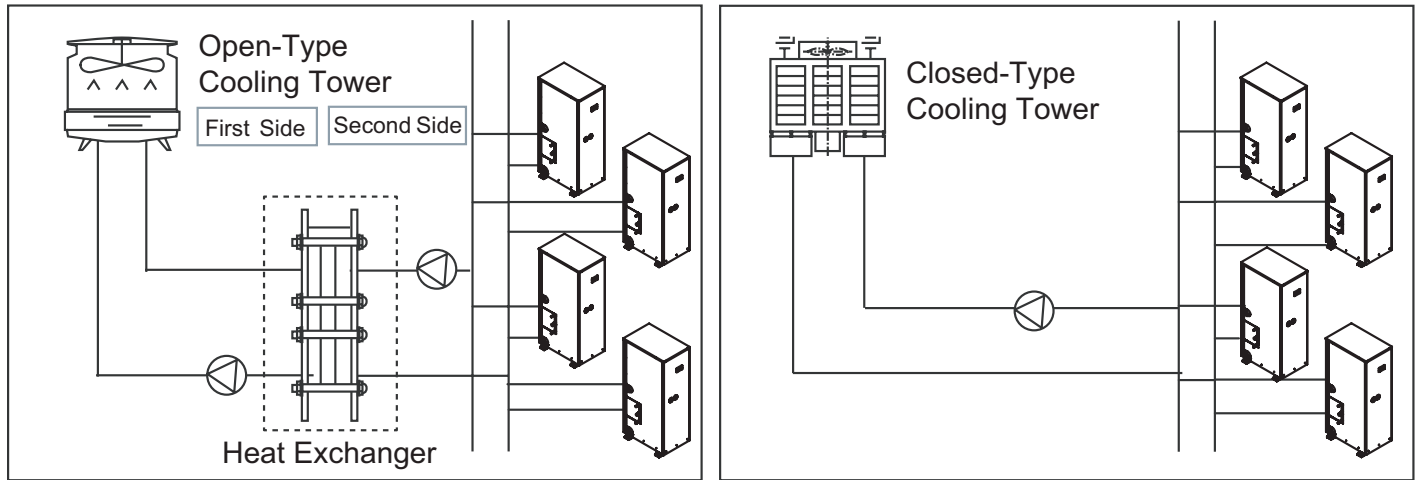

Figure 60: Open-Type and Closed-Type Tower Design Schematic.



### Open-Type Cooling Tower with Heat Exchanger

A heat exchanger is installed between the cooling tower and water source unit system piping, and the temperature difference between the first and second sides is maintained constantly.

#### Note:

When using an open cooling tower or open geothermal wells, using an intermediate heat exchanger is recommended to protect the water source unit from contamination.

### Closed-Type Cooling Tower

Heat-source water of the cooling tower is supplied directly to the water source unit system.

## Expansion Tank

All closed loop systems should have a bladder type expansion tank installed. The expansion tank protects the equipment from excess pressures due to expansion and contraction of water in the loop as the temperature changes.

## Heat Source

There are several sources for heat that can be used for this system including:

- Electric boiler
- Gas boiler
- Solar heat with storage tanks
- Ground source heat
- Steam heat from remote central plant

## Geothermal Water Circuit Design

Instead of a cooling tower / boiler, Multi V IV Water Source Units may use a geothermal system that is properly sized to match the WSU's capacity. This year round heating and cooling system uses a two (2) pipe closed loop water circuit that circulates water continuously, maintaining water temperatures between 23°F and 113°F for heating, 23°F and 113°F for cooling. When the WSU is in cooling mode, heat is rejected to the geothermal system. When the WSU is in heating mode, heat is absorbed from the geothermal system.

Multi V IV WSUs have factory-installed stainless steel plate heat exchangers. To protect these heat exchangers, it is recommended to use closed geothermal water loops. Should open geothermal systems be used, an intermediate heat exchanger should be installed to isolate the water source unit from contaminants in the water system. Open geothermal loops may contain minerals, biological contaminants, corrosive agents, or other scale, fouling or corrosion-causing substances that could degrade performance or shorten the life of the heat exchanger and WSU.

Antifreeze can be used for all geothermal applications. Refer to "Freeze Protection" on page 78 for recommended levels of antifreeze and correction factors.

### Piping System

The following field supplied components must be installed at each Multi V Water IV Water Source Unit. Refer to Figure 61.

- Flow switch at outlet in the horizontal pipe. Wire the flow switch to communication terminals and set to shut off the WSU if flow falls below 50% of WSU design flow. The flow switch must be the normally-closed type. The flow switch must be installed within at least five (5) pipe diameters downstream and at least three (3) pipe diameters upstream of elbows, valves, or reducers which can cause turbulence and lead to flow switch flutter.
- Strainer with minimum 50 mesh screen at inlet. Clean the mesh screen twenty-four (24) hours after startup, and then clean regularly to prevent water flow blockage.
- A water balancing valve, circuit setter, or flow control valve to regulate proper water flow to each WSU.
- Dielectric pipe unions to prevent the possibility of galvanic corrosion.
- Pressure gauges at inlet and outlet.
- Thermometers at inlet and outlet.
- Flexible connectors at inlet and outlet.
- Shutoff valves at the inlet and outlet to permit service of the WSU.
- Condensate drain trap per local code.
- Service port with hose connections at inlet and outlet to flush the WSU heat exchanger when isolated from the water loop system.

Other considerations:

- Inhibitors should be used in the water loop, especially if water temperature operates above 104°F.
- Maintain water quality requirements.

Figure 61: Field-Supplied Components and Connections for Multi V Water IV WSU.

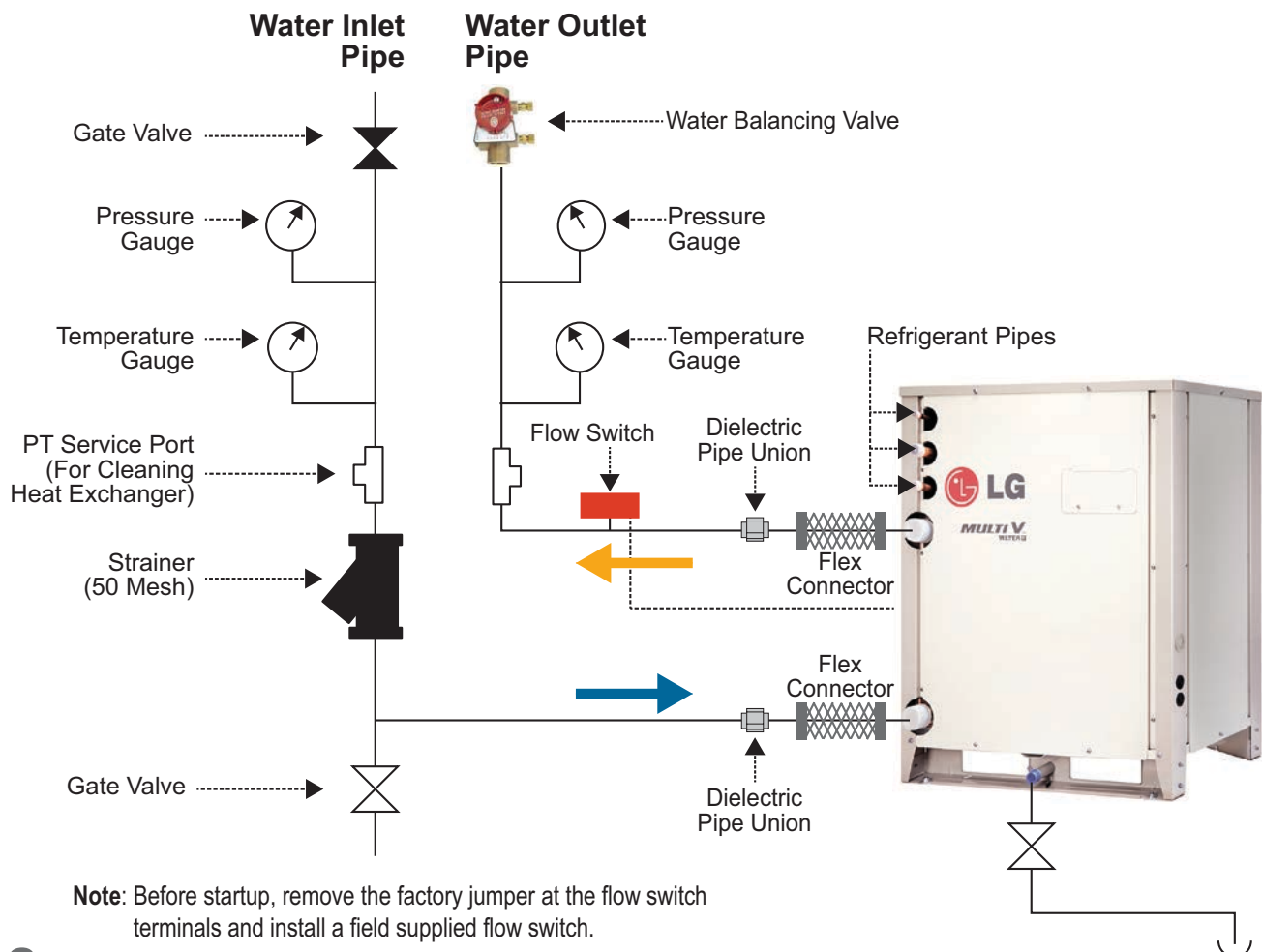

### Freeze Protection

Protect the water piping system from freezing during winter conditions. When the water source unit is in heating mode, the water loop temperature is reduced and there is risk of slush forming and / or the loop water freezing. In applications with leaving water temperatures below 40°F, freeze protection should be considered. Use of ethylene glycol, propylene glycol, or methanol is acceptable. Table 60 shows recommended levels of antifreeze concentration; however, the addition of antifreeze may lower performance of the water source unit due to reduced heat transfer and added pressure drop. Figure 62 and Figure 63 are graphic representations of the data in Table 60.

The calculations below require the nominal capacity and the nominal pressure drop of the appropriate model(s) of WSU. Refer to the General Data Tables beginning on page 9 for these values. To determine the effect of adding antifreeze on WSU performance, calculate the net capacity and the net pressure drop as follows:

#### WSU Net Capacity due to Antifreeze

1. Refer to Table 60 and locate the type of antifreeze used and the percentage by weight of the antifreeze in the water piping system.
2. Cross-index the cooling (or heating) row with the percentage by weight column to find the cooling (or heating) correction factor.
3. Multiply the WSU nominal capacity by the cooling (or heating) correction factor. The result is the net capacity due to the effect of antifreeze.

#### WSU Net Pressure Drop due to Antifreeze

1. Refer to Table 60 and locate the type of antifreeze used and the percentage by weight of the antifreeze in the water piping system.
2. Cross-index the pressure drop row with the percentage by weight column to find the pressure drop correction factor.
3. Multiply the WSU nominal pressure drop by the pressure drop correction factor. The result is the net pressure drop due to the effect of antifreeze.

Table 60: Antifreeze Capacity Correction Factors.

Antifreeze Type	Item	Antifreeze Percentage by Weight				
		10%	20%	30%	40%	50%
Methanol	Cooling	0.998	0.997	0.995	0.993	0.992
	Heating	0.995	0.99	0.995	0.979	0.974
	Pressure Drop	1.023	1.057	1.091	1.122	1.160
Ethylene Glycol	Cooling	0.996	0.991	0.987	0.983	0.979
	Heating	0.993	0.985	0.997	0.969	0.961
	Pressure Drop	1.024	1.068	1.124	1.188	1.263
Propylene Glycol	Cooling	0.993	0.987	0.98	0.974	0.968
	Heating	0.986	0.973	0.96	0.948	0.935
	Pressure Drop	1.040	1.098	1.174	1.273	1.405

Figure 62: Cooling Capacity Correction Factor Chart.

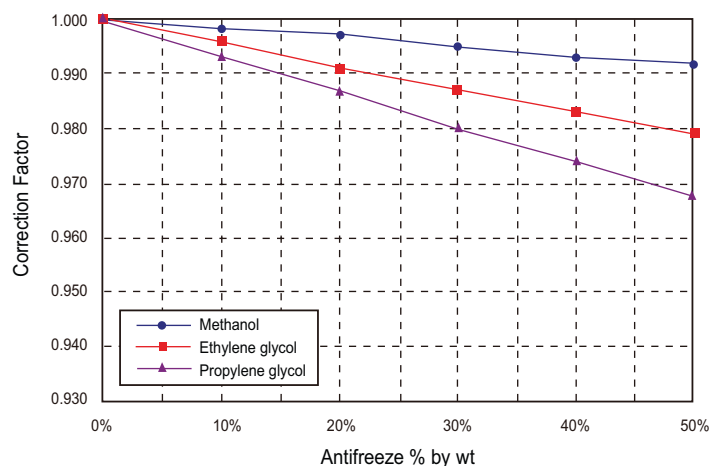
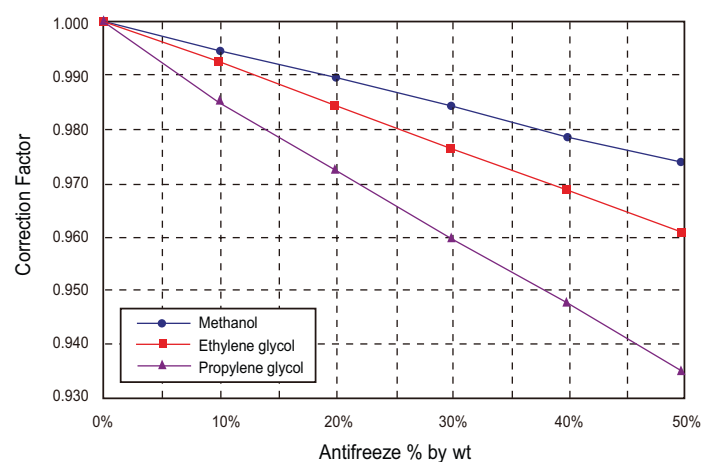

Figure 63: Heating Capacity Correction Factor Chart.



### Water Quality Requirements

Impurities in the water can influence the performance and life expectancy of the water cooled unit. Use a local water treatment professional to test and treat the water. Maintain the following levels:

Table 61: Minimum Water Quality Requirements.

Basic Item	Closed Type System		Effect	
	Circulating Water	Supplemented Water	Corrosion <sup>1</sup>	Scale <sup>1</sup>
pH (77°F)	7.0 ~ 8.0	7.0 ~ 8.0	•	•
Conductivity (77°F) mS/m	Below 30	Below 30	•	•
Chlorine ions (mg Cl/ℓ)	Below 50	Below 50	•	
Sulfate ions (mg SO <sub>4</sub> <sup>2</sup> /ℓ)	Below 50	Below 50	•	•
Acid consumption (pH4.8) (mgCaCO <sub>3</sub> /ℓ)	Below 50	Below 50		•
Total Hardness (mg CaCO <sub>3</sub> /ℓ)	Below 70	Below 70		•
Calcium Hardness (mg CaCO <sub>3</sub> /ℓ)	Below 50	Below 50		•
Ionic-static silica (mg SiO <sub>2</sub> /ℓ)	Below 30	Below 30		•
<i>Reference Item</i>				
Iron (mg Fe/ℓ)	Below 1.0	Below 0.3	•	•
Copper (mg Cu/ℓ)	Below 1.0	Below 0.1	•	
Sulfate ion (mg SO <sub>4</sub> <sup>2</sup> /ℓ)	Must not be detected	Must not be detected	•	
Ammonium ion (mg NH <sub>4</sub> <sup>+</sup> /ℓ)	Below 0.3	Below 0.1	•	
Residual chlorine (mg Cl/ℓ)	Below 0.25	Below 0.3	•	
Free carbon dioxide (mg CO <sub>2</sub> /ℓ)	Below 0.4	Below 4.0	•	
Stability index			•	•

<sup>1</sup>The "•" mark for corrosion and scale means that there is a possibility of occurrence.

**Note:**

- Use inhibitors in the water loop, especially if water temperature operates above 104°F.
- Purge air from the system.

### Pipe Insulation

Water pipe insulation is suggested in the following conditions:

- If water pipe is subject to freezing.
- If water can condense on surface of pipe from ambient room temperatures higher than temperature of water in the pipe.
- On boiler water pipes to save energy losses from heat source.
- On condensate drain lines.
- Where required by local code.

If water temperature is maintained at 68°F in winter and 86°F in summer, insulation is not required (unless required by local code).

### Device Protection Details

#### Strainer on Water Pipe

Install a strainer with  $\geq 50$  mesh on the water source unit inlet piping to protect the water source unit. If the strainer is not installed, the heat exchanger can be damaged by particles in the water supply.

- The water-supply circuit in the plate-type heat exchanger is comprised of many small paths / channels.
- If a strainer with 50 mesh or more is not included, foreign particles can partially block the water flow.
- When the system operates in heating mode, the heat exchanger functions as an evaporator; therefore, the temperature of the coolant supply drops the temperature of the heat source water supply, which can result in ice forming in the water circuit.
- As heating operation progresses, the channels can be partially frozen, which may damage the plate-type heat exchanger.
- If the heat exchanger is damaged, the coolant supply and the heat-source water supply will mix, and the system will not function.

Figure 64: Potential Heat Exchanger Damage.

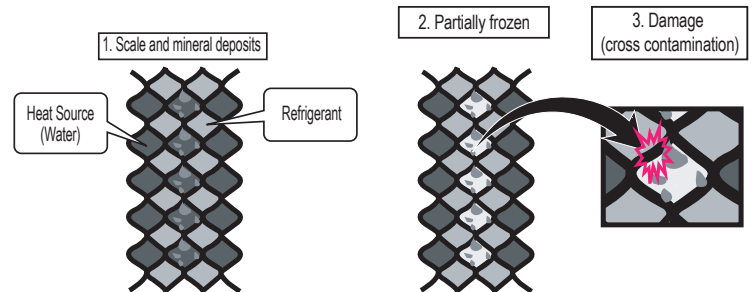

#### Flow Switch

- It is recommended to install a flow switch on the water out pipe of the water source unit.
- The flow switch should be rated for 208-230V and be a normally closed type. The flow switch is the first protection device when water flow is not supplied. If the required water flow is not present after installing the flow switch, the water source unit displays error code CH24 and stops operating.
- When setting the flow switch, set to 50% of the nominal flow rate of the WСУ model. Refer to the General Data Tables beginning on page 9 for the nominal flow rate. This flow switch setting will satisfy the required minimum flow rate of 50%.
- If the Variable Water Flow Control Kit is also installed, set the flow switch minimum flow rate to 40% of the nominal flow rate instead of 50%.
- Select a flow switch following the pressure specification of the water supply system.

#### Note:

- If the set value does not satisfy the minimum flow rate, or if the set value is changed by the user arbitrarily, it can result in performance deterioration or system failure.
- If the water source unit operates with a hard water supply, the heat exchanger can be damaged or system failure can occur.
- If the water source unit displays a CH24 or CH180 error code, it is possible that the interior of the plate-type heat exchanger is partially frozen. If partial freezing occurs, resolve the partial freezing issue and then operate the water source unit again. Causes of partial freezing include insufficient heat water flow rate, water not supplied, insufficient coolant, and foreign particles inside the plate-type heat exchanger.

Figure 65: Flow Switch Diagram.

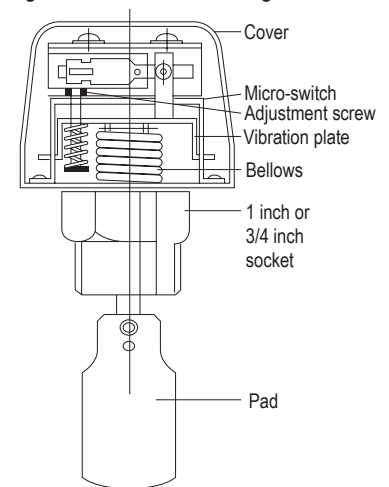



### Flow Switch

- The flow switch must be installed at the horizontal pipe of the water source unit's heat water-supply outlet. Verify the direction of the water flow before installation. (Picture 1)
- Remove the jumper wire and connect to the communication terminals (4[A] and 4[B]) of the water source unit's control box. (Pictures 2, 3) Open the flow switch cover and check the wiring diagrams before connecting the wires. Wiring methods can vary by flow switch manufacturer.
- If necessary (and after consulting with an LG representative), use the flow rate detection contact to adjust flow rate to within the minimum range. (Picture 4)  
Minimum flow rate range of this product is 50%. Adjust the flow switch to the contact point when the flow rate reaches 50%. (Minimum flow rate range is 50%; When installing the Variable Water Flow Control Kit, set minimum water flow to 40% of nominal flow rate.)

### Note:

- *If the product operates while the flow switch contact point is out of the permitted range, it can result in performance deterioration or system failure.*
- *Use a normally-closed type flow switch.*



Picture 1

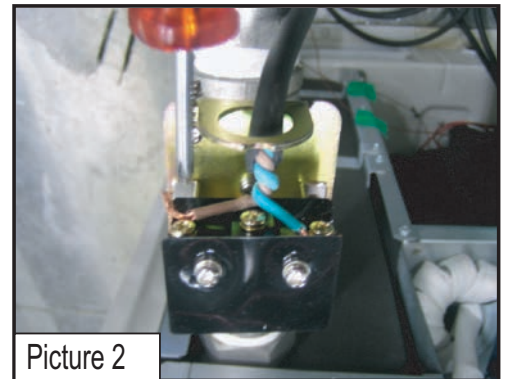

Picture 2

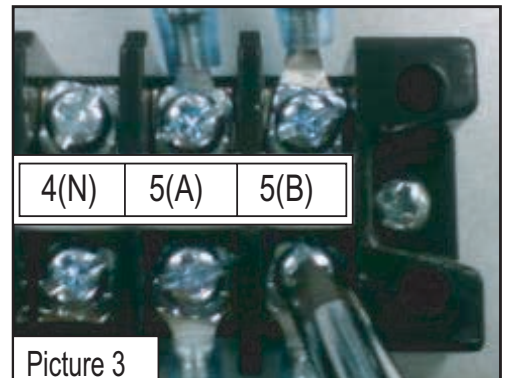

Picture 3

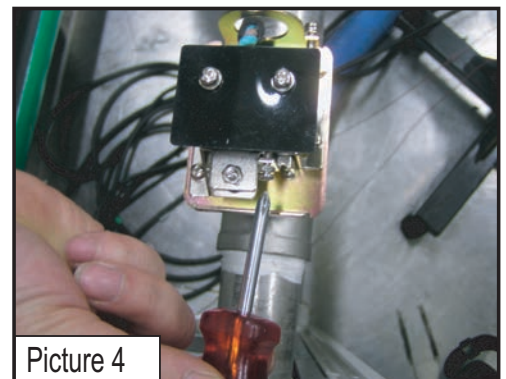

Picture 4

# WATER CIRCUIT INSTALLATION



## Piping System Specifications

### Solenoid Valves (Optional)

Solenoid valves may be installed to shut off water flow to the water source unit when the unit turns off. Solenoid valves are field supplied, must be rated for 208-230V, and must be wired to terminals L1 and L2 on the water source unit PCB as shown in Figure 66. Remove water source unit power, set the PCB DIP switches as shown in Figure 67, then reapply power.

### ⚠ WARNING

High voltages capable of causing death are used in this equipment. Remove water source unit input power before performing this procedure. Failure to observe this warning can result in death or severe injury.

### Note:

Field-supplied solenoid valve must be a normally closed type.

Figure 66: Flow Switch and Solenoid Valve Wiring

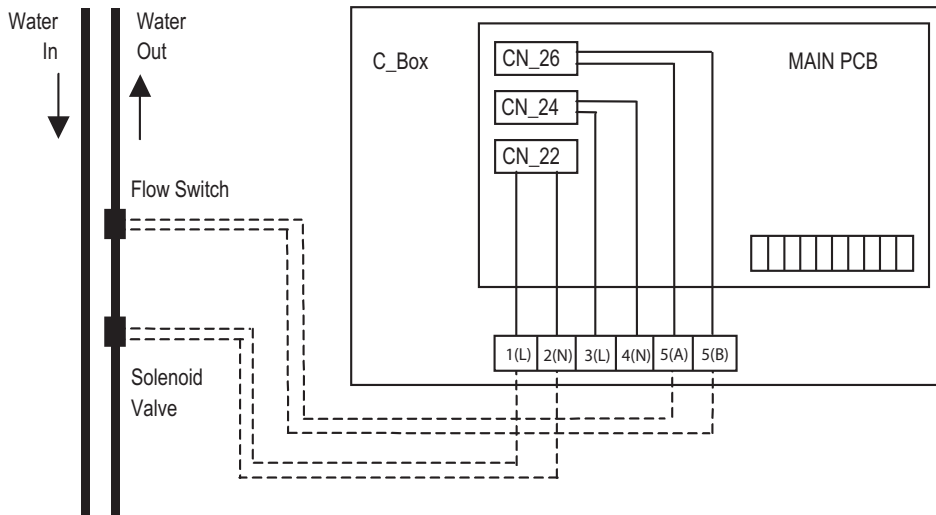
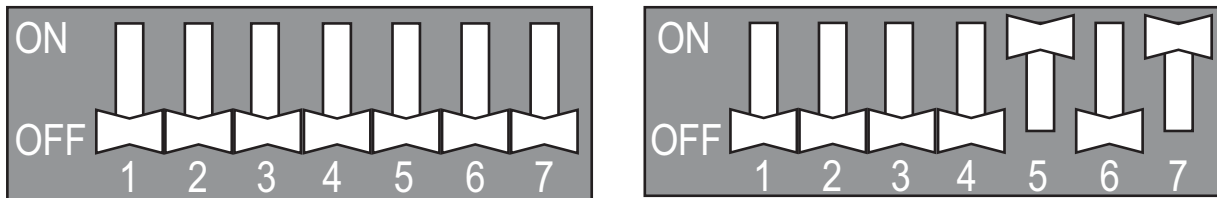

Figure 67: WSU DIP Switch Settings for Solenoid Valve Control by WSU



### Variable Water Flow Valve Control Kit PWFCKN000 (Optional)

When entering water temperature is lower than 59°F, variable water flow control kit PWFCKN000 is required. LG recommends installing a variable water flow control kit on each water source unit.

**Note:**

- Field-supplied modulating water control valve must be 24 volt, normally-closed.
- Minimum flow rate cannot be less than 40% of normal flow rate.
- Variable flow control kit sends 0–10 volt signal to the modulating valve. 10 volts is full open valve position. As building load drops and compressor slows, the signal reduces to close the valve. 1 volt is the minimum flow position of 40% of rated flow. Zero volts is valve fully closed.

### Variable Water Flow Valve Control Kit Installation

Install the kit as follows:

**⚠ WARNING**

High voltages capable of causing death are used in this equipment. Remove water source unit input power before performing this procedure. Failure to observe this warning can result in death or severe injury.

1. Remove power from the water source unit.
2. Install the transformer, I/O module, and terminal block inside the water source unit chassis. Secure components with screws.
3. Connect component wiring as shown in Figure 68.
4. Position DIP switch 5 (function 4) to the ON position.
5. Reconnect water source unit power.

Figure 68: Variable Water Flow Valve Control Kit

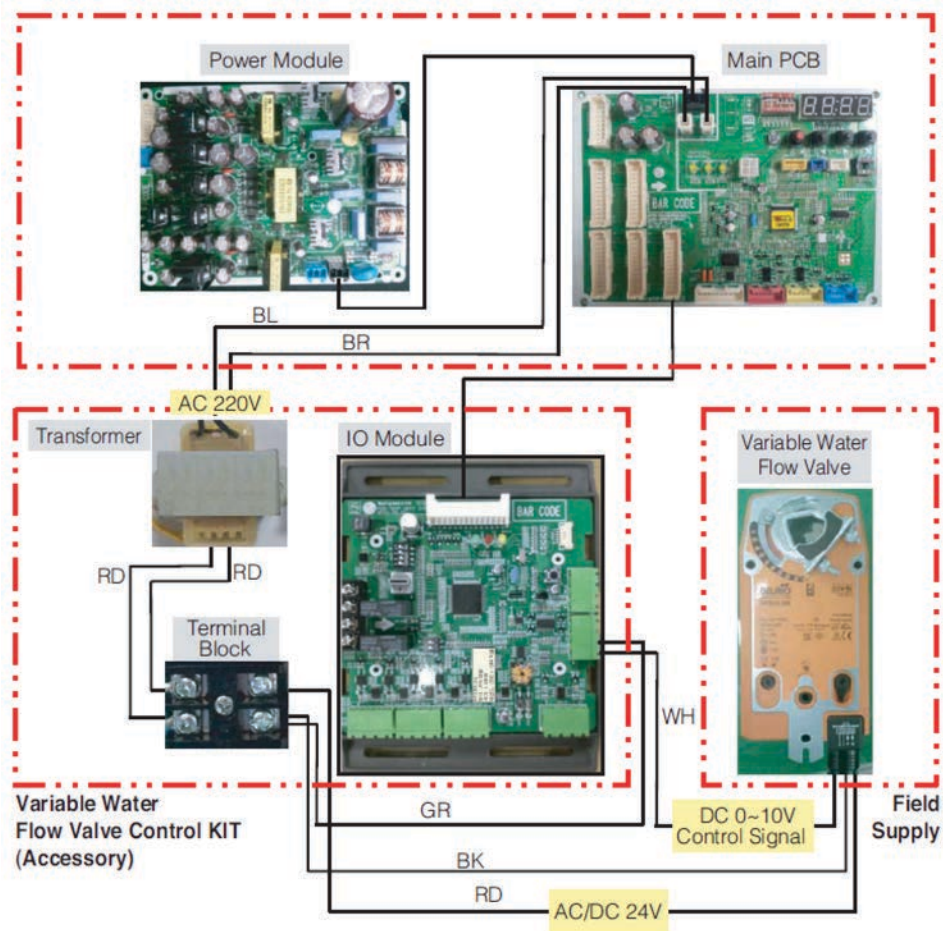

BL=blue; BR=brown; RD=red; BK=black; WH=white; GR=green

### ⚠ WARNING

- All power wiring and communication cable installation must be performed by trained service providers working in accordance with local, state, and NEC regulations related to electrical equipment and wiring, and following the instructions in this manual. In case of conflict between local, state, or NEC regulations and the instructions in this manual, follow the local, state, or NEC regulation.
- Undersized wiring may lead to unacceptable voltage at the unit and may cause unit malfunction and / or a fire hazard.
- Properly ground the water source unit and indoor units. Ground wiring must always be installed by a qualified technician. Do not connect ground wire to refrigerant, gas, or water piping; to lightning rods; to telephone ground wiring; or to the building plumbing system. Failure to properly provide an NEC approved earth ground can result in equipment malfunction, property damage, electric shock, physical injury or death. Install appropriately sized breakers / fuses / overcurrent protection switches and wiring in accordance with local, state, and NEC regulations related to electrical equipment and wiring, and following the instructions in this manual. Generated overcurrent may include some amount of direct current. Using an oversized breaker or fuse may result in equipment malfunction, property damage, electric shock, physical injury or death.
- Consider ambient conditions (temperature, direct sunlight, inclement weather, etc.) when selecting, installing, and connecting the power wiring.

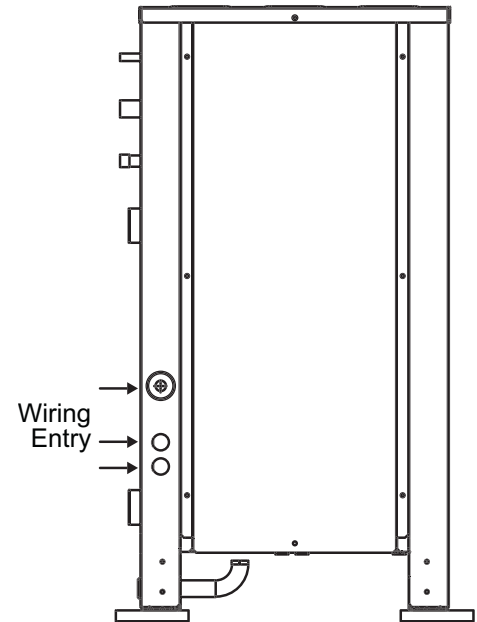

Figure 69: Access Holes for Power Wiring and Communication Cable Connections.

## Separating Power Wires and Communication Cables

- Install the power wiring with a minimum of two (2) inches of separation from the communication cables to avoid operation problems caused by electrical interference. Do not run power wiring and communication cables in the same conduit.
- If it is unavoidable to run the power wiring and communication cables alongside each other for long distances, refer to the table below for minimum recommended distances between the cables.

Table 62: Power Wire and Communications Cable Minimum Required Separation Minimum Allowable Distances.

Capacity of Power Supply Wiring (current)		Recommended Minimum Distance <sup>1,2</sup>
100V or more	10A	11-13/16 inches
	50A	19-11/16 inches
	100A	39-3/8 inches
	> 100A	59-1/16 inches

<sup>1</sup>The figures above are based on parallel lengths up to 328 feet long. For lengths in excess of 328 feet, the distances will have to be recalculated in direct proportion to the additional line lengths involved.

<sup>2</sup>If interference between the power and communication signals continues, increase the distance until the interference is no longer a problem.

### Note:

- Do not bunch the power wiring and communication cables together.
- Do not run the power wiring and the communication cable in the same conduit.

### Power Supply / Power Wiring Specifications

- Water source unit (WSU) and indoor units (IDU) must obtain power from separate breakers:
  - Water source unit: 3 phase, 3 wire, 60Hz, 208-230V or 460V
  - Indoor units: single phase, 60 Hz, 208-230V (Indoor units draw minimal power. Where permitted by NEC and local code, it may be prudent to connect multiple indoor units to a properly sized breaker.)
- Select power supply wire type and size based on NEC and local codes. Maximum allowable voltage fluctuation is  $\pm 10\%$  of unit nameplate rated value.
- Properly ground the water source unit and indoor units per NEC and local code.

Figure 70: Typical Power Wiring.

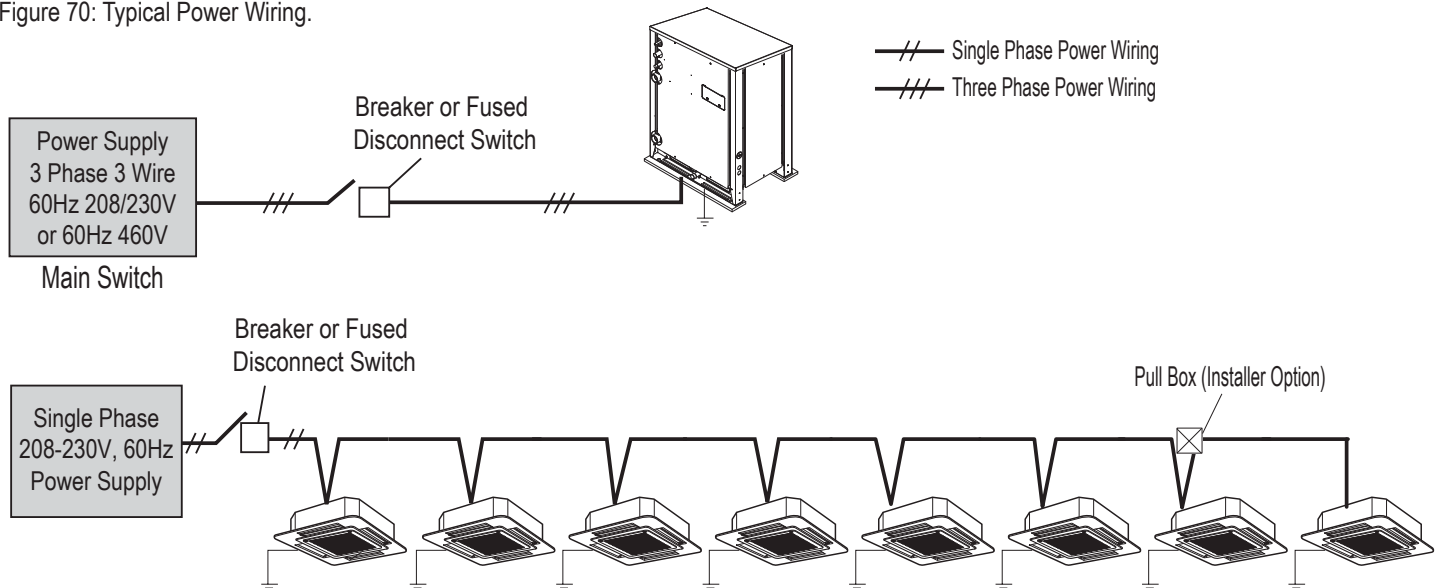

### Connecting the Power Wiring

#### ⚠ WARNING

- WSU input power is capable of causing severe injury or death. Do not touch bare input power wire or terminals. Ensure input power is OFF before connecting power wiring to the WSU.
- If power wires are not properly terminated and firmly attached, there is risk of fire, electric shock, and physical injury or death.
- Refer to the installation manual for each model of IDU for details of connecting power to each model of IDU.

Best practice is to use ring or spade terminals to terminate power wiring at the power terminal block. If ring terminals or spade clips are not available, terminate the wires as follows:

- Firmly attach the wire; secure in a way to prevent external forces from being imparted on the terminal block.
- Use an appropriately sized screwdriver for tightening the terminals.
- Do not overtighten the connections; overtightening may damage the terminals.

Figure 71: Typical Ring Terminal.

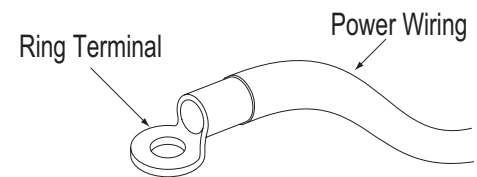

## Communication Cable

### General Communication Cable Specifications

- Use two-conductor, 18 gauge, stranded and shielded cable between the water source unit and the indoor units.
  - Insulation material as required by local code
  - Rated for continuous exposure of temperatures up to 140°F
  - Maximum allowable cable length is 984 ft.
- Use copper-bearing ring or spade terminals to terminate communication cables.
- Firmly attach the cable; provide slack, but secure in a way to prevent strain on the cable and terminal block connections.
- Connect and terminate communications cable connecting the water source unit to indoor unit(s) in a daisy chain (bus) configuration starting at the water source unit.
- Terminate the cable shield to a grounded surface at the water source unit only. Cable shields between connected devices shall be tied together and continuous from the water source unit to the last device connected.
- Refer to the installation manual for the specific model of IDU for detailed communication cable installation instructions.

Figure 72: Water Source Unit Communications Schematic Diagram.

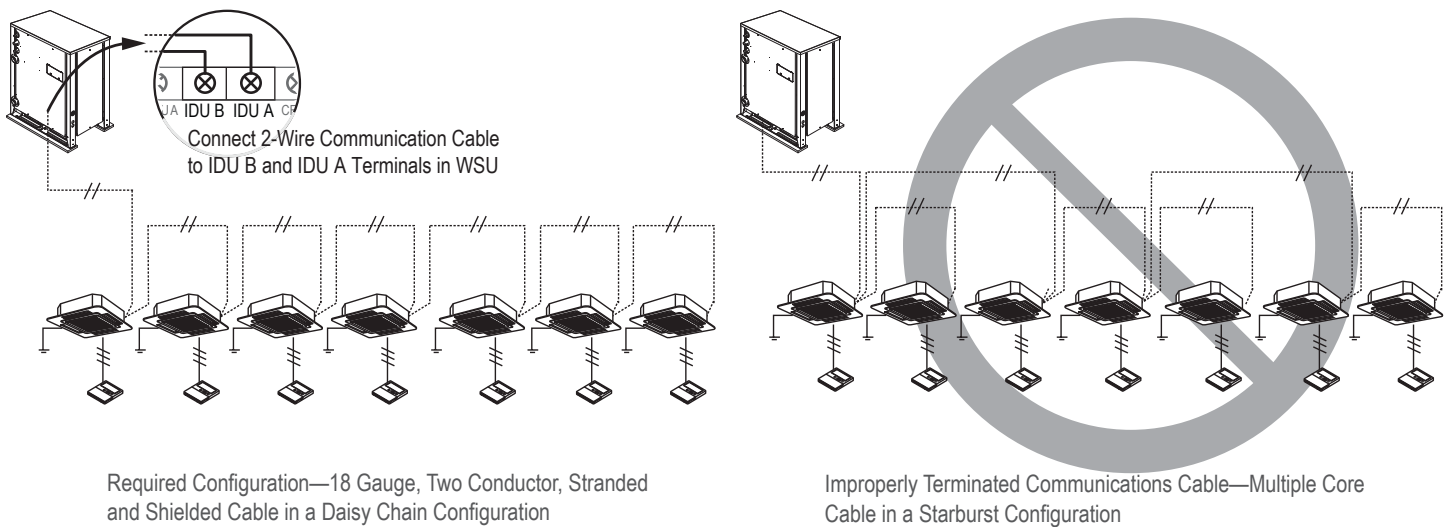

Required Configuration—18 Gauge, Two Conductor, Stranded and Shielded Cable in a Daisy Chain Configuration

Improperly Terminated Communications Cable—Multiple Core Cable in a Starburst Configuration

**Note:**

- Ring and spade terminals used to connect communications cables **MUST** be copper bearing. Do **NOT** use terminals that are galvanized or nickle plate over steel.
- Always verify the communication cable is connected to the proper communications terminals on the WSU(s). Never apply line voltage power to the communication cable connection. Line voltage can damage the circuit boards in the WSU(s) and the IDU(s).
- The shield of the communications cable connecting the water source unit to the indoor units should be grounded only to the water source unit frame. Tie the shield of each cable segment together using a wire nut at each indoor unit.
- Never ground the shield of the communications cable to the indoor unit frame or any other ground point.
- Position the WSU communication cables away from power wiring. Refer to minimum spacing requirements in Table 62.
- Never use a common multiple-conductor communications cable. Each communications bus must be a separate cable (i.e., one bus between WSU(s) and indoor units, and one bus between WSU(s) and central controller(s)). If communications cables of separate systems are wired using a common multiple-conductor cable, it will result in a poor communications signal and unacceptable system operation.

### Communication Cable Between the WSU and the Central Control Device

- This communications cable is field provided, 18 gauge, two conductor, stranded and shielded.
- Use cable with insulation material as required by local code.

Connect all central control devices such as AC Smart II, AC Smart Premium, ACP, BACnet and LonWorks gateways, and energy recovery ventilators all on the same cable. Order does not matter, but polarity does. Keep “A” terminals with “A” terminals, and “B” terminals with “B” terminals. Starting at the water source unit, terminate the cable on terminals CEN A and CEN B. Route the cable as needed between each device. Follow the cable routing parameters described in “Separating Power Wires and Communication Cables” on page 84,

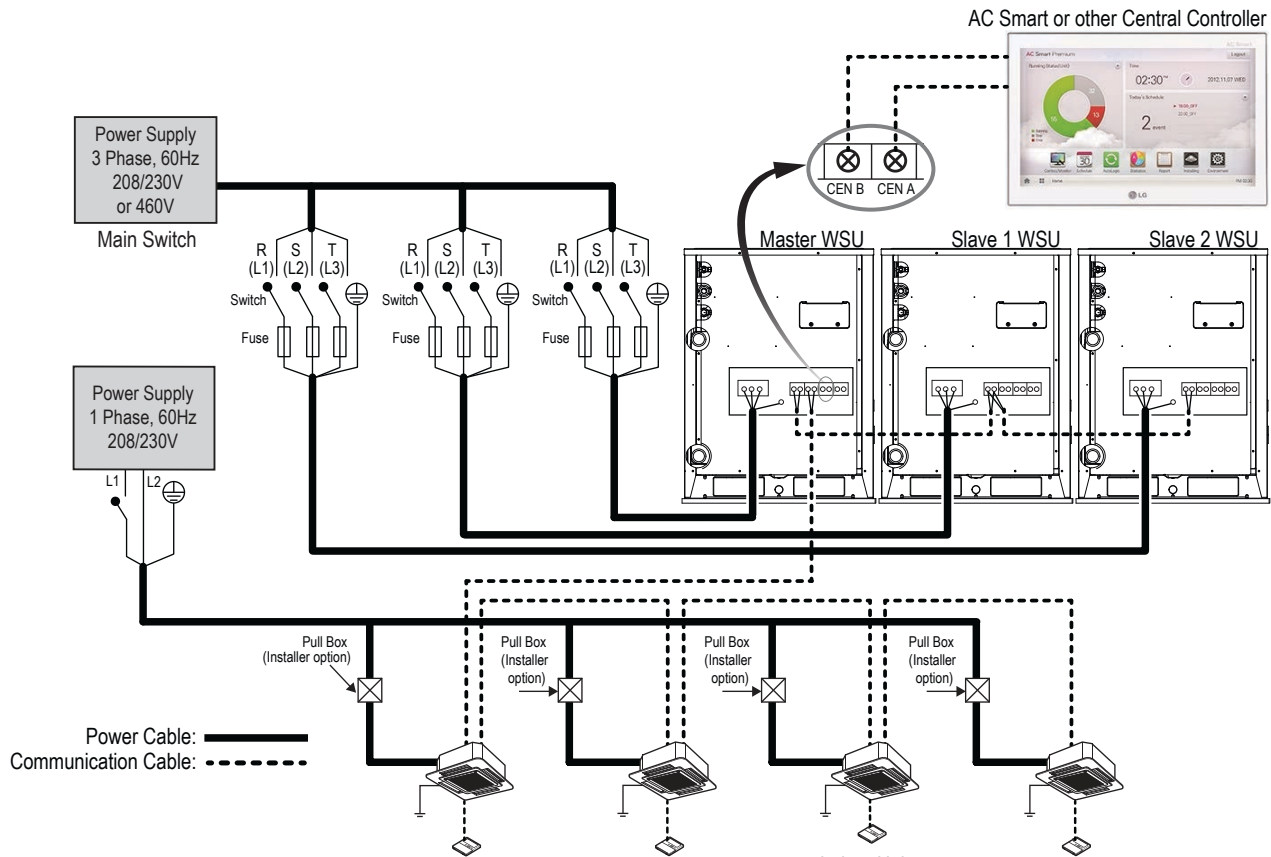

### ⚠ WARNING

- Never apply line voltage power to the communications cable terminal block. If contact is made, the system may be damaged.
- Always include some allowance in the wiring length when terminating. Provide some slack to facilitate removing the electrical panels while servicing.
- Always ground indoor units to help prevent electrical shock accidents or communication signal disruption. Do not connect ground wires to the refrigerant pipes.
- Install a main shutoff switch that interrupts all power sources simultaneously.
- Operating the system in reversed phase can damage the compressor or other components. If there is a possibility of reversed phase, phase loss, momentary blackout, or the power goes on and off during operation, install a field-supplied phase loss protection circuit.

### Note:

- The GND terminal at the main circuit board is a negative terminal for a dry contact connection. Do not connect ground wires to this terminal.
- Ensure the terminal connections of the master and slave water source unit connections are matched, A terminals to A terminals and B terminals to B terminals.

Communications Between IDUs and Master WSU

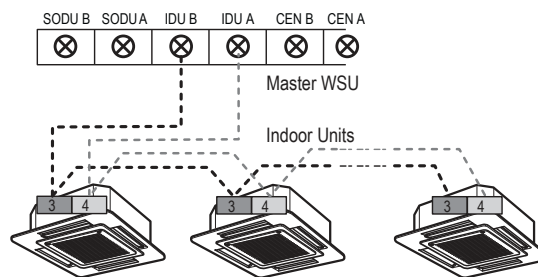

Communications Between WSUs

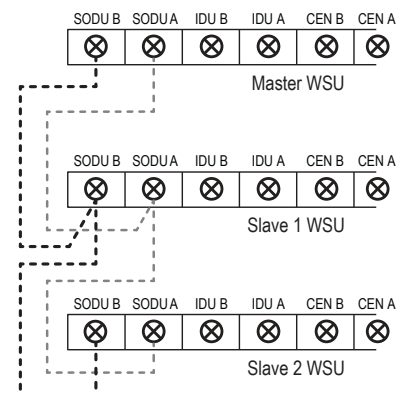

# ELECTRICAL CONNECTIONS

## ARWB Series Heat Recovery Systems (208-230V and 460V)

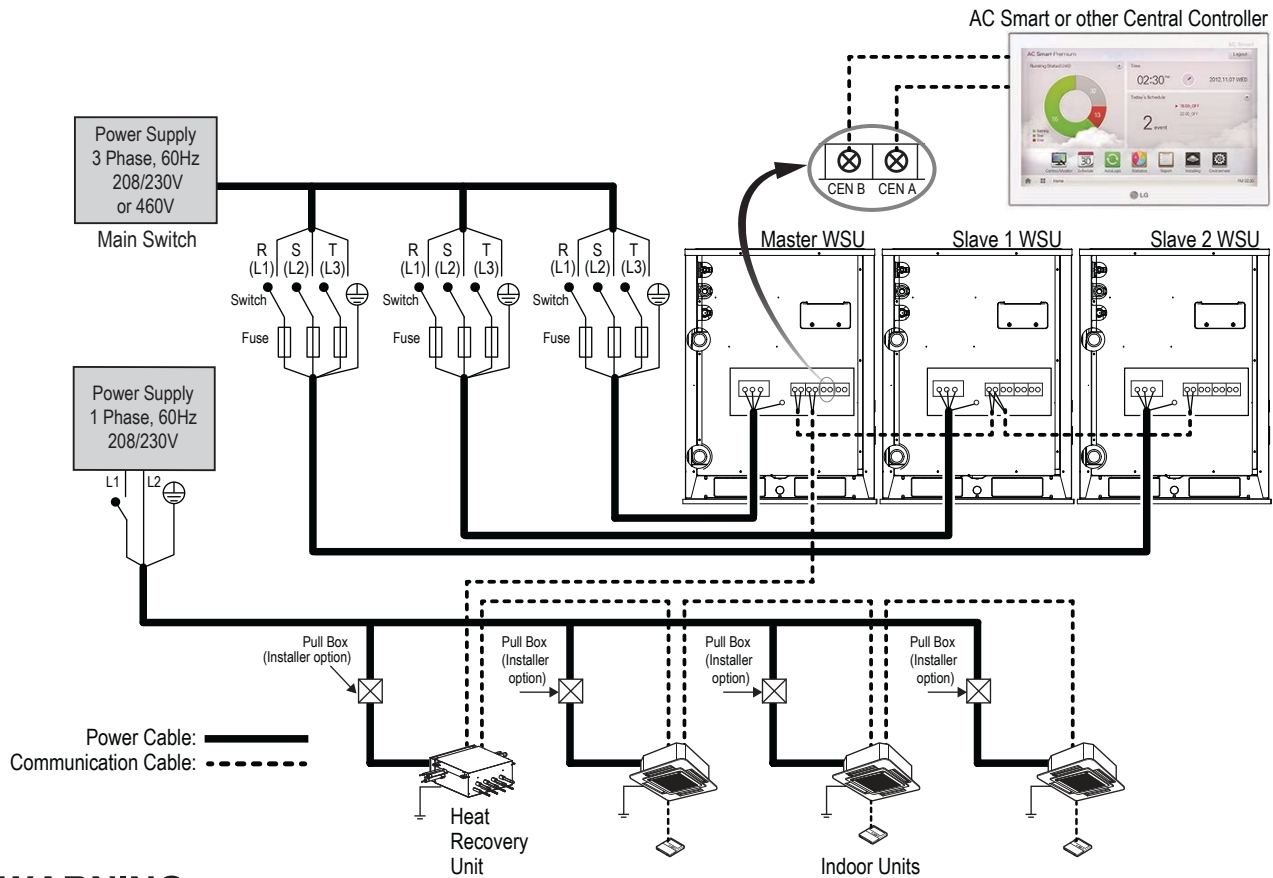

### ⚠ WARNING

- Never apply line voltage power to the communications cable terminal block. If contact is made, the system may be damaged.
- Always include some allowance in the wiring length when terminating. Provide some slack to facilitate removing the electrical panels while servicing.
- Always ground indoor units to help prevent electrical shock accidents or communication signal disruption. Do not connect ground wires to the refrigerant pipes.
- Install a main shutoff switch that interrupts all power sources simultaneously.
- Operating the system in reversed phase can damage the compressor or other components. If there is a possibility of reversed phase, phase loss, momentary blackout, or the power goes on and off during operation, install a field-supplied phase loss protection circuit.

### Note:

- The GND terminal at the main circuit board is a negative terminal for a dry contact connection. Do not connect ground wires to this terminal.
- Ensure that the terminal connections of the master and slave water source unit connections are matched, A terminals to A terminals and B terminals to B terminals.

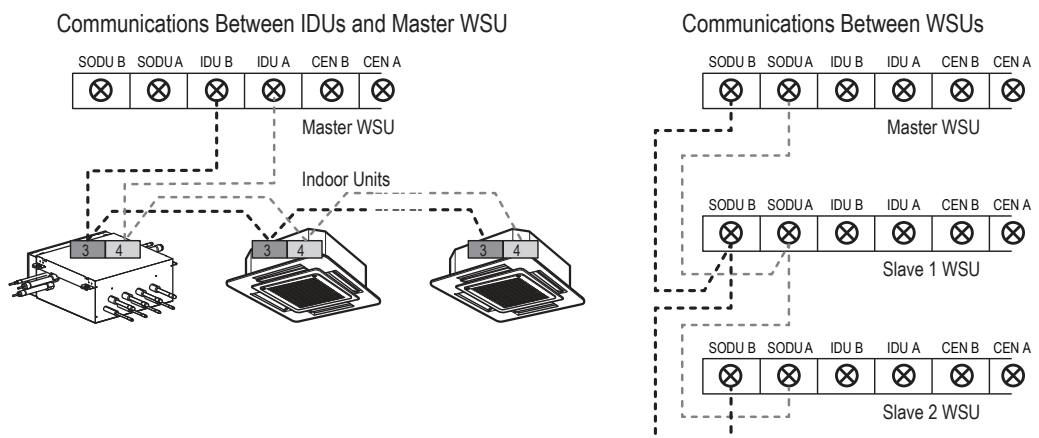



### IDU Communication Cable

Refer to Figure 73 and Figure 74. Connect the communication control cables between the master WSU and the IDUs.

**Note:**

*Communications cables must be 18 gauge, stranded, shielded, and grounded at the water source unit(s) only. Maintain polarity throughout the communication network.*

Figure 73: Multi V Water IV ARWN Series Heat Pump System—Daisy-Chain Communications Cable Wiring.

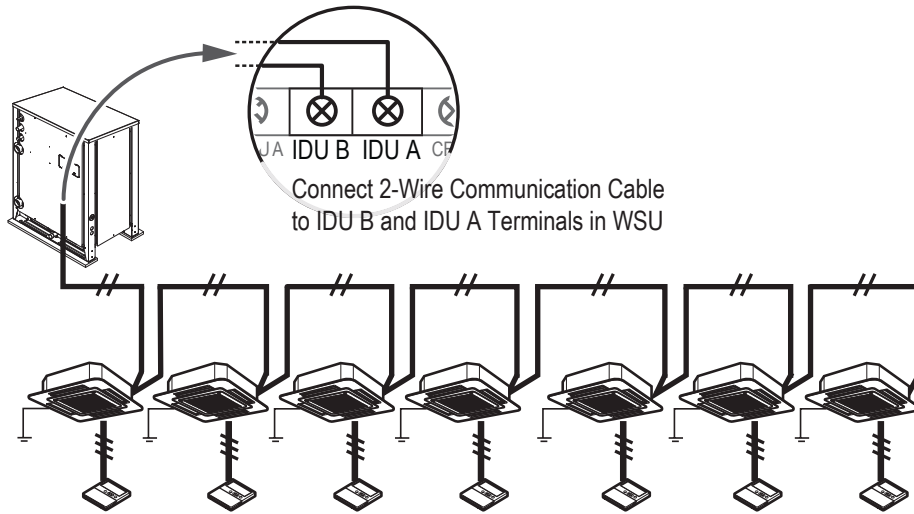
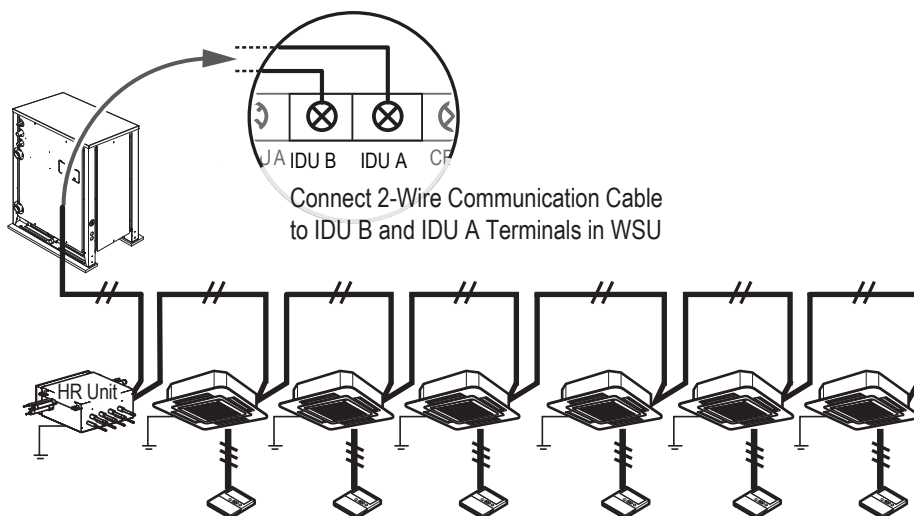

Figure 74: Multi V Water IV ARWB Series Heat Recovery System—Daisy-Chain Communications Cable Wiring.



## Zone Control of Indoor Units

### Zone Control Connections

Up to eight indoor units can be connected to one port of a heat recovery unit and can be controlled as a group. Figure 75 shows a typical application with both zone controlled and individually controlled IDUs. The WSU to IDU communications bus must be connected in a daisy chain configuration from IDU to IDU. For zone control of multiple IDUs, the control communications cable from the wall controller must connect first to the master IDU and then is daisy chained to the other IDUs in the zone. Controlling IDUs individually requires one wall controller per IDU.

**Note:**

- The capacity of the indoor units on one port of a heat recovery unit (the zone) cannot exceed 54kBtu/h.
- The maximum total capacity of indoor units connected to one PRHR042A Heat Recovery Unit cannot exceed 192kBtu/h.
- The maximum number of indoor units connected to one PRHR042A Heat Recovery Unit is 32.
- The maximum number of indoor units connected to one port of a PRHR042A Heat Recovery Unit is 8.
- All indoor units in a zone must be in the same mode, either heating or cooling. Auto Changerover and Mode Override functions are not available in zone control.

Figure 75: Typical IDU Zone Control Connections

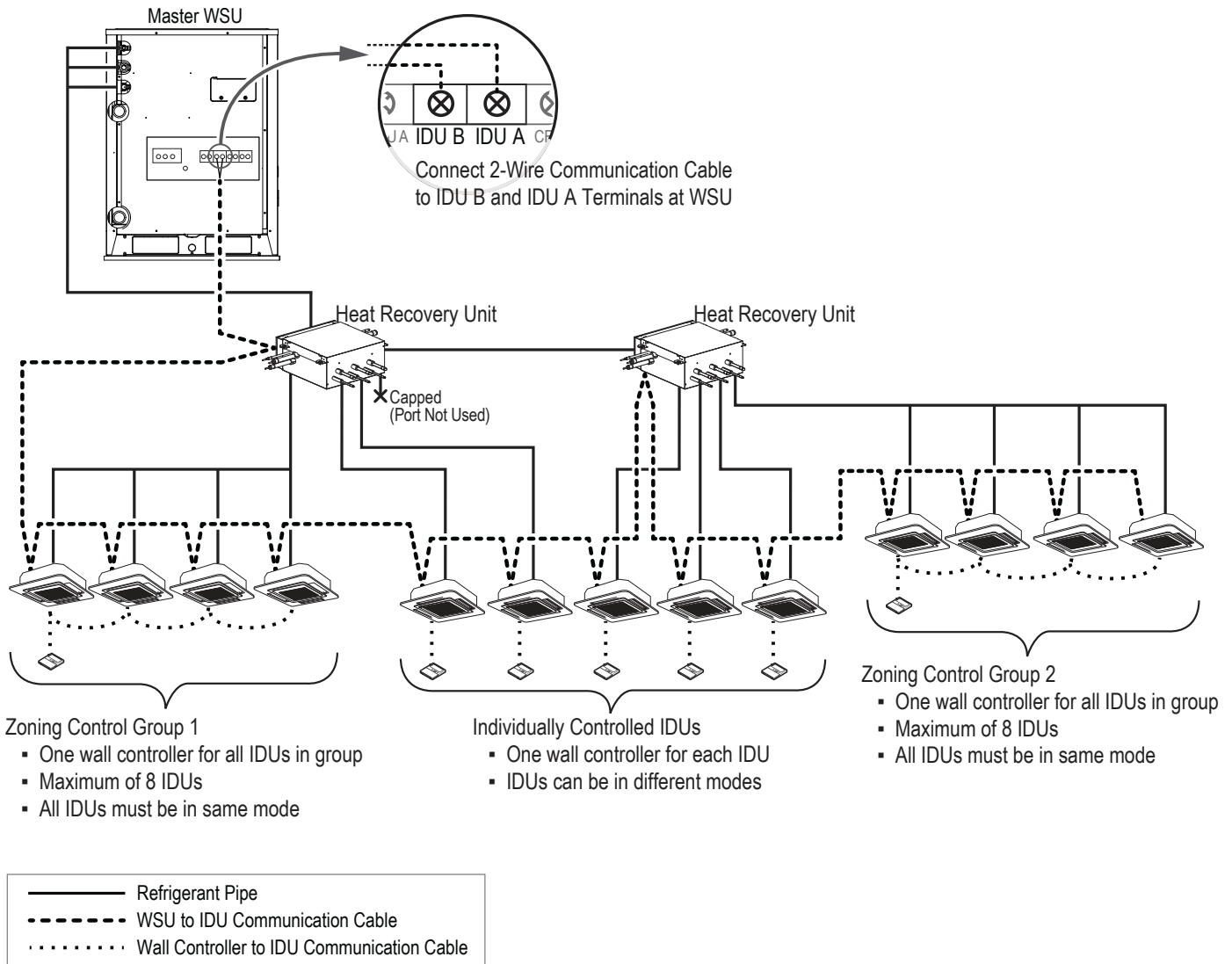

### Communication Cable Between the Indoor Units and the Wall-Mounted Zone Controller

- Use only LG-provided three-conductor communications cable between the indoor unit and the wall-mounted zone controller.
- NEVER splice, cut, or extend cable length with field provided cable. If the length must be extended, use the LG Extension Kit (sold separately). A maximum of four (4) kits (up to 165 feet) can be connected together.
- Set the indoor unit operating parameters with DIP switches on the indoor unit control PCB or by setting the zone controller. Refer to the indoor unit installation manuals for details.

**Note:**

*Cable connected to Zone Controller is the factory default connection.*

### Communication Cable Between Multiple Indoor Units Operating as a Group (Group Control)

- If any indoor units operate as a group, use one (or multiple) three-core Group Control Kit (sold separately) containing extension and Y-splitter cables. One (1) group control cable kit is required for each indoor unit in the group except for the last indoor unit.
- Always use an LG provided group control communications cable (Group Control Kit; sold separately) between the indoor unit and the wall-mounted zone controller.
- NEVER splice or cut the communications cable. Do not shorten the cable or extend cable length with field provided cable.
- Before running cable, decide which indoor unit will be the master indoor unit. The zone controller connects to the master.
- Adjust the appropriate DIP switch at each indoor unit in the group to identify it as the master or a slave. On wall mounted indoor unit models, set the assignment using the handheld remote controller.
- Use a daisy chain configuration and connect all of the group's indoor units together starting at the Master unit.

**Note:**

*Cable connected to Zone Controller is the factory default connection.*

Figure 76: Indoor Unit to Zone Controller Connection.

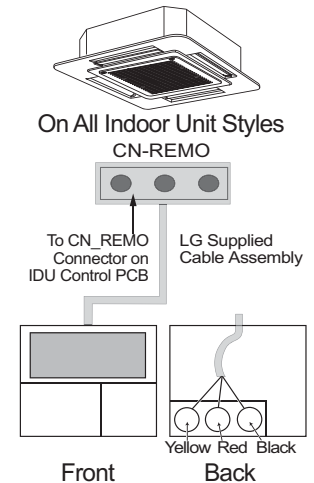
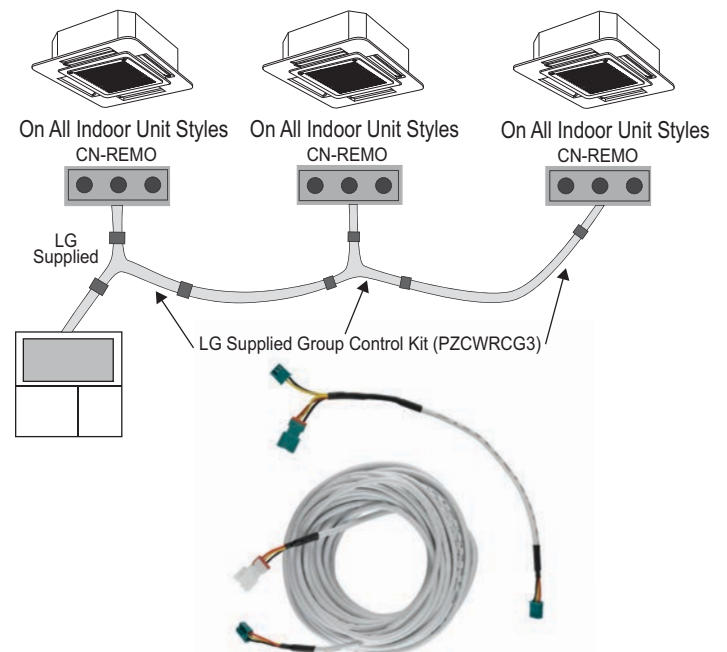

Figure 77: Indoor Unit Group to Zone Controller Connections.



## Option Settings for All Water Source Units

### Option Settings

Set DIP switch 01 as necessary for your Multi V Water IV system.

**Note:**

*Before setting these options, ensure the input power to all indoor units is OFF. Ensure the water source unit is ON but the compressor is not operating. Restore power to the indoor units after this procedure is complete.*

During normal operation, switch 5 of DIP switch SW01 is set to OFF. To enable option configuration, set switch 5 to ON. Use the forward, back, confirm and cancel buttons on the main circuit board to select and set system options. The display above the buttons shows the selected function and its options.

Use forward and back to scroll to the desired function and press confirm to select it. Then use forward and back to scroll between the options for that function and press confirm when the proper option is displayed. Pressing confirm stores the selected option in EEPROM on the circuit board.

Figure 78: DIP Switch 01 Operation.

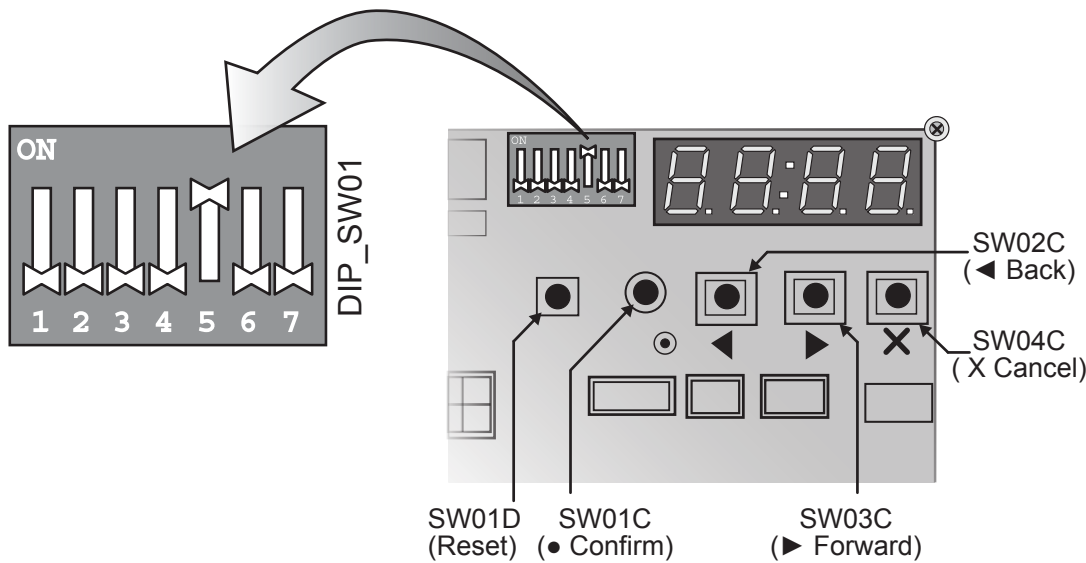

Table 63: DIP Switch 01 Option Settings.

Function		Options
Display	Description	
Fn1	Cool and Heat Selector	OFF / op1–op2
Fn2	Geothermal Mode Setting (Entering water temperature lower than 50°F)	ON / OFF
Fn3	Solenoid Valve 220V Output	ON / OFF
Fn4	Variable Water Flow Control	ON / OFF
Fn5	WSU Address	0–255
Fn7	Target Pressure Adjusting	ON / op1–op3
Fn8	Compressor Crankcase Heater	ON / OFF

### Generation 4 Equipment

The latest versions of LG's indoor units and water source units are designated Generation 4 (Gen 4). For Gen 4 units to operate with Gen 4 features, the air conditioning system must meet the following requirements:

- All indoor units, heat recovery units, and water source units must be Gen 4.
- All water source units must have Gen 4 software installed.
- Water source units DIP switch 3 must be set to ON (factory default setting is OFF).
- All controllers must support Gen 4 features.

Figure 79: Location and Setting of WSU DIP Switch 3

ODU/WSU DIP Switch No. 3

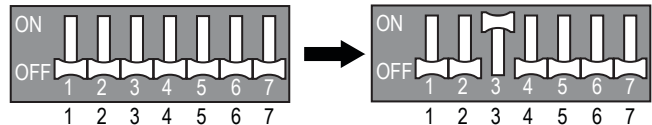

Figure 74 shows the ODU DIP switch. Table 77 lists how combining different components will affect system operation. Table 78 lists the serial numbers of air and water source units that have Gen 4 software. All air and water source units, indoor units, heat recovery units, and controllers in a system must be Gen 4 compatible or the system will not operate with Gen 4 features.

Table 64: System Component Combinations and Operation Status

Air/Water Source Units*	Indoor Unit(s)**	Heat Recovery Unit(s)	Water Source Unit DIP Switch No. 3	Operation Status
Gen 4	Gen 4 ONLY	Model 2A ONLY	Must be ON	System will operate WITH Gen. 4 features.
Gen 4	Gen 4 ONLY	Model 2A ONLY	OFF	System will operate but WITHOUT Gen. 4 features.
Gen 4	Gen 4 ONLY	Any combination of Models 0A, 1A, 2A	Must be OFF (factory default)	Does NOT include Gen. 4 features. System will not operate if DIP Switch No. 3 is ON, and an error code will be generated.
Gen 4	Any combination of Gen 2 and Gen 4	Model 2A ONLY	Must be OFF (factory default)	
Gen 4	Any combination of Gen 2 and Gen 4	Any combination of Models 0A, 1A, 2A	Must be OFF (factory default)	
Gen 2	Any combination of Gen 2 and Gen 4	Any combination of Models 0A, 1A, 2A	N/A***	Does not include Gen. 4 features.

\*Gen 4 Water Source Units = Multi V Water IV with Gen 4 software (see table below for Gen 4 serial numbers).

Gen 2 Water Source Units = Multi V Water II, Multi V Water IV without Gen. 4 software.

\*\*Gen 4 Indoor Units model numbers end in "4"; Gen 2 Indoor Units model numbers end in "2" or an "A", including Hydro Kit.

\*\*\*DIP Switch No. 3 on Gen 2 water source units is not related to Gen 4 features as it is with Gen 4 water source units.

Table 65: Serial Numbers of Water Source Units with Gen 4 Software

Air/Water Source Unit Model Type	Multi V IV Water Source Heat Pump	Multi V IV Water Source Heat Recovery
Serial Number of Air/Water Source Units with Gen 4 Software	504***** and Higher	

### Prepare the Electrical System

1. Verify correct, clean, specified power is at the line side of each system component's power disconnect switch.
2. Note if the green LED light on the component PCB board is illuminated.
3. If a Dynamic V-8 VL air cleaner is installed on a high static ducted model indoor unit, verify power has been provided to the air cleaner controller. Verify by observing that the LED in the center of the disconnect plate is illuminated.
4. If a zone controller is connected to the component, verify the LCD screen displays current operational characteristics.

### Indoor Unit Auto Addressing

#### **⚠ WARNING**

*During this procedure, only a properly-licensed electrician should operate power input disconnect switches. Never look at a disconnect switch when closing. Turn away from the switch when closing. Incorrect wiring could cause the disconnect to explode, resulting in physical injury or death.*

#### **⚠ WARNING**

*Upon successful completion of the auto addressing function, an unintentional compressor start can occur unless the communications cable to the indoor units is removed from the water source unit terminals IDU(A) and IDU(B). Do NOT open the service valves or attempt to start water source unit compressors until directed by the LG-authorized Commissioning Agent. Major damage to the unit piping and compressors will occur, and there is a risk of explosion, suffocation, physical injury, and / or death.*

#### **Note:**

*During the pre-commissioning process for Gen. 4 systems, do not change any DIP switch settings except for SW01 switch number 3 which should be ON to enable Gen. 4 features. All other switches should be left in the OFF position on ODU DIP switch SW01. Refer to "DIP Switch Settings for Generation 4 Equipment" on page 93 for proper setting of DIP switch 3.*

#### Auto Addressing Procedure

#### **Note:**

*If the Auto Address Procedure is not successful, the compressor(s) will not start when power is applied.*

#### **Note:**

*While this routine runs, the unit runs a self-diagnostics check. At completion, the LED should be clear and nothing displayed. Diagnostic process should take from three (3) to seven (7) minutes.*

1. Verify all that all indoor units connected to the system have power to the PCB board AND all zone controller system start buttons are OFF.
2. Remove the maintenance access panel and unit control box cover from the water source unit. Place panels and screws in a secure area.
3. Verify the communications cable between the indoor units and the water source unit is terminated at the water source unit terminals IDU(A) and IDU (B).
4. Verify the shield on the communications cable is grounded at the water source unit only.
5. At the water source unit PCB, verify DIP switch SW01 is set as necessary for your system. Refer to "DIP Switch Settings for Generation 4 Equipment" on page 93.
6. If the LED on the main PCB is not observable from the power disconnect switch location, have a second person cycle power on the water source unit. Leave input power disconnect in the ON position.
7. Check the water source unit current configuration code(s). Observe the unit setup codes listed in Table 66 on the LED display on the WSU main PCB. Each code will display for approximately two (2) seconds.

Table 66: Setup Code Display Sequence.

Sequence	Code Displayed	Description
1	See Description	Capacity of Master WSU in horsepower (HP). Refer to Table 15 through Table 18 for HP values.
2	See Description	Capacity of Slave 1 WSU in HP. Refer to Table 15 through Table 18 for HP values.
3	See Description	Capacity of Slave 2 WSU in HP. Refer to Table 15 through Table 18 for HP values.
4	See Description	Total capacity in HP of all WSUs. Refer to Table 15 through Table 18 for HP values.
5	2 or 3	2 = Heat Pump; 3 = Heat Recovery
6	22 or 46	22 = 208-230V system; 46 = 460V system
7	1, 2, or 3	Model type. 1 = General; 2 = Tropical; 3 = Factory

### Auto Addressing Procedure, continued

8. Verify how many indoor units and heat recovery units (HR systems only) are connected to the system.
9. Press and hold red Auto Address Button (Figure 80) for about five (5) seconds. Release when "88" appears on the LED. The system begins the auto addressing sequence listed in Table 67. After three (3) to seven (7) minutes, the display will flash a number for about ten (10) seconds indicating how many indoor units the system successfully communicated with.
10. If the auto addressing procedure is successful, this number should match the known number of installed indoor units
11. Upon completion of the auto addressing routine, the display will be blank and the system will be in standby waiting for another command.
12. Upon successful completion of the auto address procedure, record the system address assigned to each indoor unit by the auto address procedure in the column provided on the Pre-commissioning Device Configuration Worksheet.
13. After recording the system addresses assigned to each device, open the water source unit disconnect. Remove the water source unit to indoor unit communications cable from terminals IDU(A) and IDU(B). Protect conductors by placing electrical tape over the bare ends.
14. Once again, verify the water source unit to indoor unit(s) communications cable is not connected to terminals IDU(A) and IDU(B) of the water source unit. Close the disconnect to reapply power to the water source unit and energize the compressor crankcase heater.
15. Replace the control panel door.

Figure 80: Auto Address Button Location.

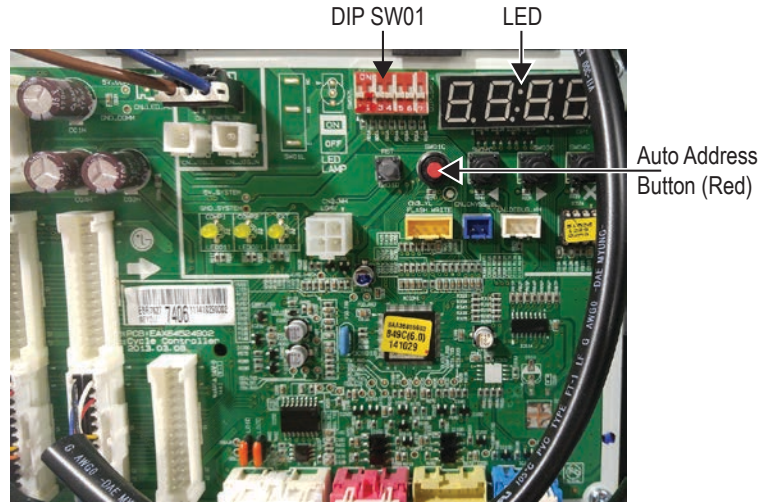

Table 67: IDU Auto Addressing Display Sequence.

Sequence	Code Displayed	Description
1	88	Auto addressing procedure begins
2	88	Auto addressing procedure continues for approximately 3 to 7 minutes (15 minutes maximum)
3	See Description	Number of indoor units found displays
4	See Description	Number of heat recovery units found displays (HR systems only)
5	Blank	Auto addressing procedure is complete

# PRE-COMMISSIONING

## Indoor Unit Auto Addressing

Figure 81: Indoor Unit Auto Addressing Procedure Flowchart.

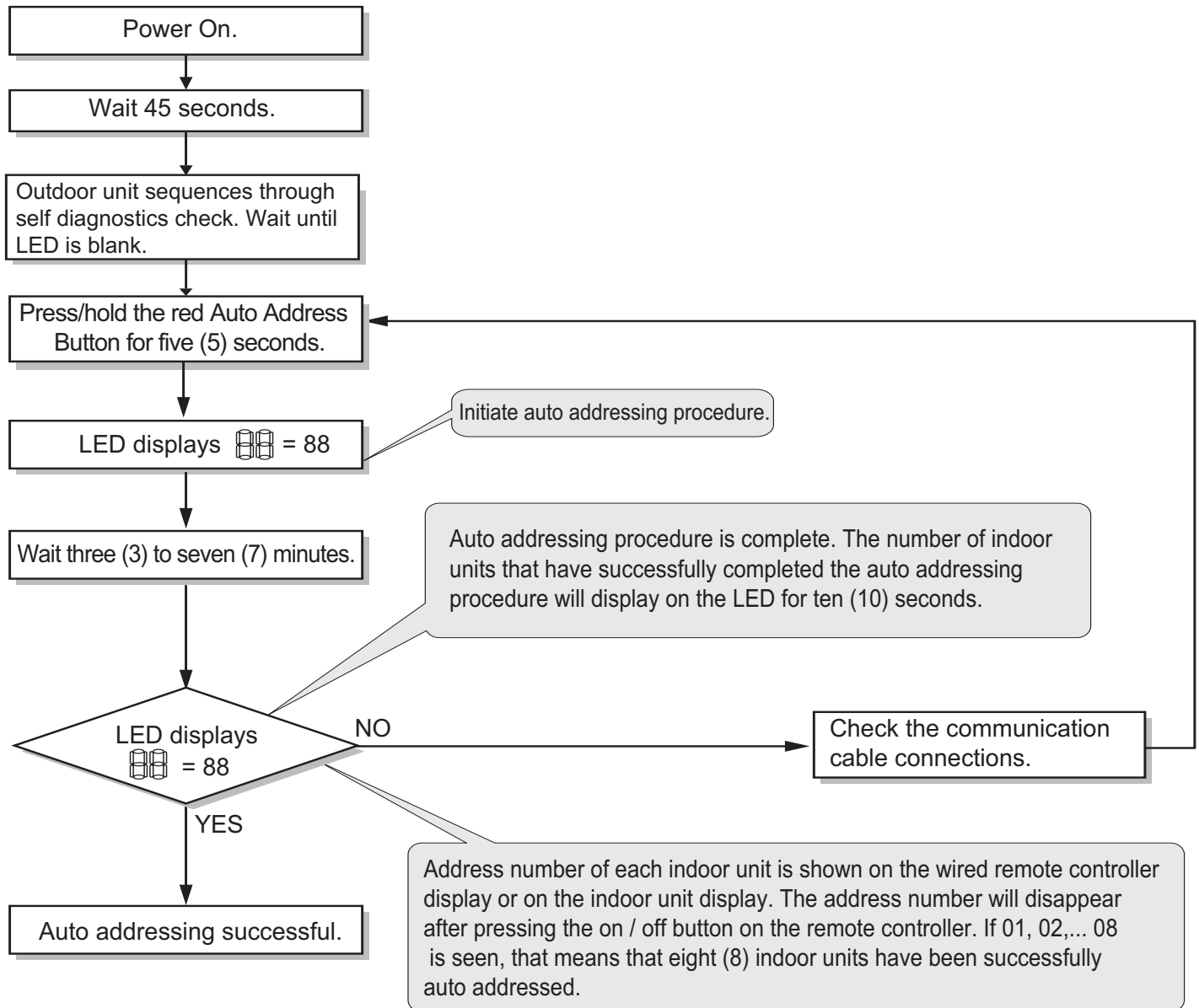



---

---

## Troubleshooting a Failed Indoor Unit Auto Addressing Procedure

If the quantity of indoor units the auto addressing procedure found is incorrect, or the “88” never disappears from the display for the seven (7) minutes, the auto address routine has failed and a communications problem exists. If the Auto Address Procedure failed:

1. Verify ALL indoor unit ON/OFF buttons are in the OFF position (i.e., on/off button NOT illuminated).
2. Check the terminations, polarity, and continuity of each conductor on the communications cable between the water source unit and the indoor units. Verify the indoor unit to water source unit communications cable is wired correctly.
  - Verify the conductor connected to the “3 (or “5” in the case of cassette frame codes TP, TN, TM) terminals on all indoor units and is terminated on the water source unit terminal tagged IDU(A).
  - In a similar fashion, verify the conductor connected to all indoor units on the “4” (or “6” in the case of cassette chassis codes TP, TN, TM) terminals and is terminated on the water source unit terminal tagged IDU(B).
3. Verify the shield of the communications cable is grounded at the water source unit only. All segment shields should be spliced together at each indoor unit and NOT grounded.
4. After repairing the communications cable, go to Step 9 of the Initiate the Auto Addressing Procedure and repeat the process until successful: Press and hold red Auto Address Button for about five (5) seconds. Release when “88” appears on the LED. After three (3) to seven (7) minutes, the display will flash a number for about ten (10) seconds indicating how many indoor units the system successfully communicated with.
5. This number should match the known number of installed indoor units if the auto addressing procedure was successful.
6. Upon completion of the auto addressing routine, the display will be blank and the system will be in standby waiting for another command.
7. Record the system address the water source unit assigned to each indoor unit by the auto address procedure in the column provided on the Pre-commissioning Device Configuration Worksheet.
8. After recording the system addresses assigned to each device, open the water source unit disconnect. Remove the water source unit to indoor unit communications cable from terminals IDU(A) and IDU(B). Protect conductors by placing electrical tape over the bare ends to prevent an accidental compressor start from occurring before the Commissioning Agent arrives.
9. Close the disconnect to reapply power to the water source unit and energize the compressor crank-case heater. Once again, verify the water source unit to indoor unit(s) communications cable is not connected to terminals IDU(A) and IDU(B) of the water source unit.
10. Replace the control panel cover.

### Terminating Group Controlled Indoor Units

If any of the indoor units were specified to operate in unison, create a group control communications circuit between the indoor units using a group control cable kit consisting of three (3) cables:

- One pigtail cable.
  - One Y-cable.
  - One extension cable segment.
1. Before proceeding with group control cable terminations, verify power is off at all group indoor units.
  2. Identify which indoor unit will be the master unit of the group. If not already recorded, record the master and the slave identity assignment to each indoor unit in the group on the Pre-commissioning Device Configuration Worksheet.
  3. Termination Procedure:
    - Starting with the Master unit, plug in the male end of the pigtail cable into the CN-REMO socket. At the last Slave indoor unit in the group, a pigtail cable is not required. Plug the male end of the extension cable coming from the previous indoor unit into the CN-REMO socket.
    - Plug the Y-cable into the pigtail at each indoor unit except for the last Slave indoor unit in the group where no Y-cable cable will be needed.
    - Connect two extension cable segments to each “Y” cable except for the “Y” cable connected to the Master indoor unit. At the Master indoor unit, connect one extension cable and the communications cable from the zone controller to the Y-cable.

### Plan the Central Control Addresses Assignments

Check with the building’s Chief Engineer for preferences about address assignments. If there are no preferences:

- Hex assignments do not have to be assigned in any particular order, or an order defined by the routing of the communications cable between the indoor units. In most cases, hex addresses can be skipped.<sup>1</sup>
- All members of a Hex Group are not required to be on the same Multi V system.
- Addresses can be assigned at random, not in any particular order, and can be skipped.<sup>1</sup>

<sup>1</sup>On AC EZ, do not skip addresses. Start with Hex address 0. Buttons have pre-assigned Hex addresses. If an address is skipped, the associated button will do nothing.

### Indoor Unit Central Control Address Assignments

A central control address is made up of two hexadecimal characters.

- The first character in the central control address is the Hex Group Identifier.  
Possible Hex Group Identifiers (in order of lowest to highest) are 0-9 followed by A-F.
- The second character in the address is the Hex Member Identifier in a Hex Group.  
Hex Member Identifiers (in order from lowest to highest) are 0-9 followed by A-F.

### Hex Address Assignment Limitations

- There is a limit of 16 Members per Hex Group
- There is a limit of 16 Hex Groups per VRF system.
- There is a limit of 256 possible Member Identifiers per Central Control (See Central Controller Communications Limitations on the next page).

Figure 82: Central Control Address Nomenclature.

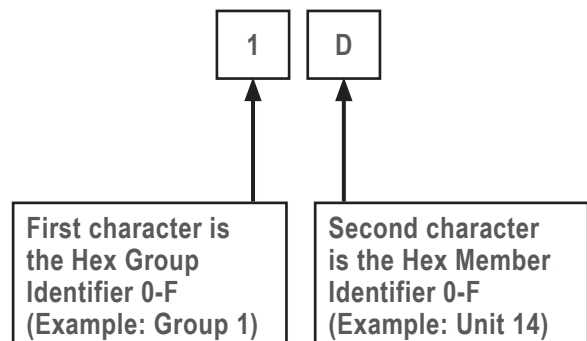

### Central Controller Communications Limitations

Each type of central controller device has a maximum number of indoor units it can communicate with.

The quantity of indoor units that can be connected to a single central control communications cable, therefore, will be defined by the central control device on that cable with the smallest Maximum Indoor Unit Quantity as shown at right.

Table 68: Central Controller Indoor Unit Connection Limitations.

Central Control Device	Maximum Indoor Unit Quantity
AC EZ	32
AC SMART Premium	128
LonWorks Gateway	64
BACnet Gateway	256
Advanced Control Platform	256

### Group Number

If the building operator wants to know which indoor units are on each water source unit, and multiple systems serve a building, assign a Group Number to each system. If there are more than 16 indoor units on a system, multiple Group Numbers may be necessary.

If the building owner wants to know which indoor units are on each floor, assign a different group number for each floor. If there are more than 16 indoor units on a floor, multiple Group Numbers may be necessary.

### Member Number

Can be assigned as desired or for example, can follow the room layout on each floor.

For each LG Central Controller product provided on the project, devise a central control address schedule and assign a central control address to each indoor unit(s) Hydro Kit(s), and ERV(s) units. Record this central control address for each component in the column provided on the Pre-commissioning Device Configuration Worksheet.

### Upload Central Control Address to the Indoor Units

For all ducted, vertical and floor standing indoor units, the central control address must be assigned using a wired zone controller. Wall-mount, ceiling cassette, ceiling suspended, and the wall/ceiling convertible indoor units, the central control address can be assigned using a wireless handheld controller or a wired zone controller.

### Power Up All Indoor Unit PCBs

Turn the disconnect for each indoor unit to the "ON" position. **DO NOT** turn the unit ON (on/off button remains off).

**Note:**

*During the following procedure, NEVER PUSH the ON/OFF (Enable operation) Button on the zone controller.*

### For Indoor Units That Are NOT Being Controlled as a Group

1. Verify the zone controller cable is plugged into CN-REMO socket on the indoor unit PCB.
2. Using the controller, go to the setup function 02 (icons are different for each controller. Refer to the controller user's manual for more information.)
3. Type in the Hex Central Control address that has been designated to the unit.
4. Repeat Steps 1 through 3 for each indoor unit in the building.

### For Indoor Units That Are Being Controlled as a Group

1. Before attempting to assign a central control address to an indoor unit controlled as a group, identify which unit in the group will be identified as the Master indoor unit and which indoor units are going to be identified as Slave units.
2. Go to the Master indoor unit, and access the PCB.
3. Verify a group control pigtail cable is plugged into the CN-REMO socket on the indoor unit PCB. If it is not, do so now by plugging the communications cable pigtail into the CN-REMO socket.
4. If the group control extension cable between the indoor units is plugged into the Y-cable, unplug the extension cable from the Y-cable.
5. If not already present, plug the zone controller communications cable into the pigtail cable.
6. Using the controller, go to the setup function 02 (icons are different for each controller. Refer to the controller user's manual for more information.) Type in the Central Control address designated for the Master indoor unit.
7. Disable power to the Master indoor unit. Do not restore Power to the Master indoor unit at this time. It will be restored in step 18.
8. If the zone controller and associated communications cable has already been permanently mounted in place, plug the Y-cable back into the pigtail and obtain a loose zone controller with a communications cable to continue programming the Slave indoor units.
9. Go to the first Slave indoor unit and disconnect the Y-cable from the pigtail.
10. Plug the zone controller communications cable into the socket on the pigtail cable. Do not push the ON / OFF button or enable indoor unit operation.
11. Using the controller, go to the setup function 02 (icons are different for each controller. Refer to the controller user's manual for more information.) Type in the Hex address assigned to the unit.
12. Change DIP switch No. 3 on the indoor unit PCB to the "ON" position.
13. Disable power to the indoor unit using the disconnect switch. Wait one (1) minute.
14. While power is off, unplug the zone controller cable from the pigtail socket.
15. Plug the group control Y-cable back into the pigtail.
16. Restore power to that Slave indoor unit, and go to the next Slave indoor unit.
17. Repeat Steps 9 to 16 for each Slave indoor unit except the last one in the group. At the last Slave indoor unit, the process is the same except unplug the group control cable from socket CN-REMO on the indoor unit PCB board and plug the zone controller cable into the same socket.
18. After all Slave indoor units have addresses assigned, go back to the Master indoor unit and restore power.

### Indoor Unit Temperature Sensing Location Selection

For each indoor unit connected to a wired zone controller, select a zone temperature sensing option. Assign one of three methods for the indoor unit to sense the zone temperature. Skip this step for indoor units controlled from a handheld (wireless) controller. Record the sensing for each indoor unit on the Pre-commissioning Device Configuration Worksheet. There are three possible strategies:

1. Use the unit-mounted return air sensor (or the optional remote wall-mounted sensor). When outdoor air is ducted to an indoor unit, the return air sensor cannot be used to control the indoor unit. Use a wall-mounted thermostat or remote temperature sensor instead of the unit-mounted return air sensor.
2. Use the sensor mounted in the zone controller.
3. Sense the temperature at the unit-mounted return air sensor (or the optional remote wall-mounted sensor) and sensor mounted in the zone controller, then control based on the temperature reading using the sensor that is farthest from set-point.

### Conduct an Air Balance for Ducted Indoor Units

For each ducted model indoor unit, confirm that the Test and Balance contractor adjusted the fan speed setting values. Record the actual fan setting value used to deliver cataloged CFMs at the jobsite static pressure conditions in the appropriate column on the Pre-Commissioning Device Configuration Worksheet. If the fan setting value was left at the factory default insert "00" in the blank.

**Note:**

*It is always best if the air balance is completed prior to a request for a commissioning agent. If the air balancing contractor has not completed the work before commissioning, the Commissioning Agent is not responsible for setting the indoor unit air flow rates, fan speed, or insure the air volume delivered at each indoor unit is per project specifications, only to spot check. Excessive or restricted airflow may impact the ability of the Commissioning Agent to successfully complete system commissioning. If problem exists, request verification from the Test and Balance contractor. If necessary, provide instruction to the air balance technician on how to adjust the indoor unit fan setting value.*

## Setting Up the Heat Recovery Unit (Heat Recovery Systems Only)

### Setting up the Heat Recovery Unit (Heat Recovery Systems Only)

#### General

Each heat recovery unit will have a unique address assign so the outdoor unit will be able distinguish it from other heat recovery units. The unique address is assigned by adjusting the rotary dials on the heat recovery unit printed circuit board (PCB).

Upon completion of the heat recovery unit address, the heat recovery unit operating parameters will be set by adjusting the positions DIP Switches on SW01M, SW02M.

#### Procedure

Before beginning the physical process of assigning heat recovery addresses, map out the address assignments using a copy of the LATS tree mode diagram.

#### Guidelines

1. Addresses must be sequential and addresses cannot be skipped.
2. Assign the lowest address to the heat recovery unit that has the largest capacity indoor unit connected to port number 1. If the capacity of all indoor units connected to port number 1 of each heat recovery unit is the same, assign address "0" to the heat recovery unit farthest away from the outdoor unit. Assign the next address to the next farthest away and so on until all heat recovery units have an address. The heat recovery unit with the highest address should be the one closest to the outdoor unit. Up to 16 boxes can be on a single system.

#### Note:

*Addressing must be performed following the detailed steps above because port number 1 on the heat recovery unit addressed "0" will remain open during the auto pipe detect procedure. If the indoor unit capacity connected to the port is relatively small compared with other units on the system, the outdoor unit high head pressure safety will trip and shut down the unit during the procedure.*

Possible settings in order of lowest to highest are: 0,1,2,3,4,5,6,7,8,9,A,B,C,D,E,F.

3. Record the address assigned to each heat recovery unit in the pertinent column on the Pre-Commissioning Device Configuration Worksheet.

#### SW05M Function (Rotary Switch for Addressing Heat Recovery Units)

- SW05M must be set to "0" when installing only one heat recovery unit.
- When installing multiple heat recovery units, address each unit with sequentially increasing numbers starting from "0".

Figure 84: Adjusting the Heat Recovery Unit Addresses.

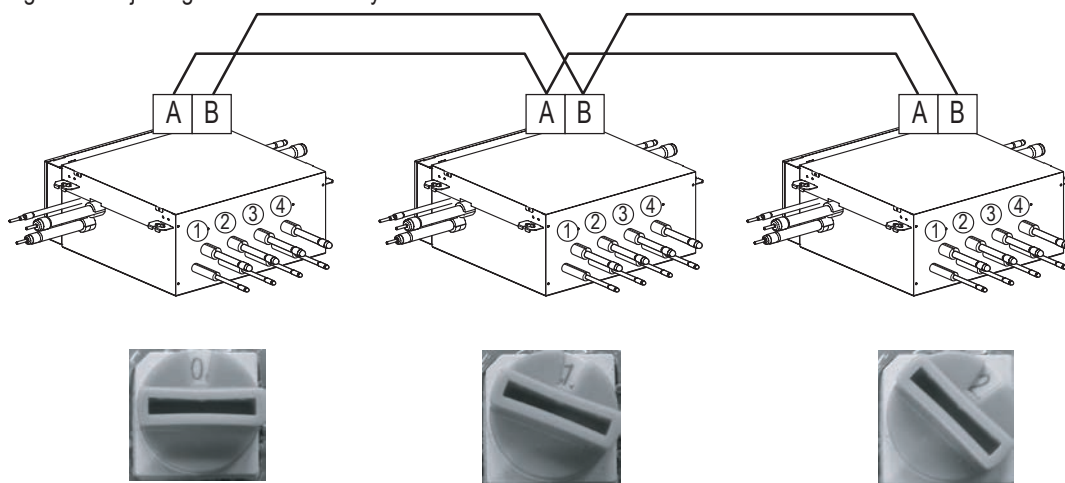
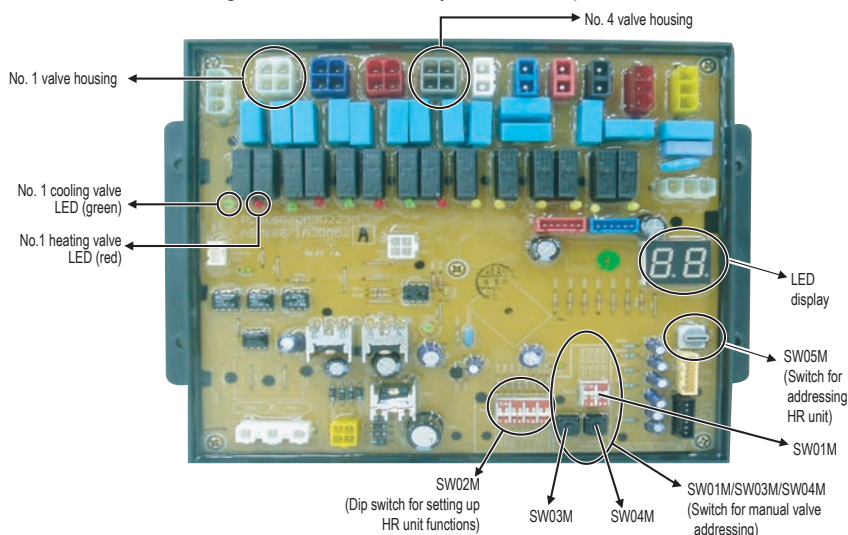

Figure 83: Heat Recovery Unit PCB Dip Switches.









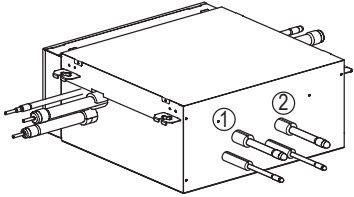
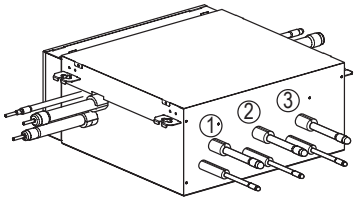
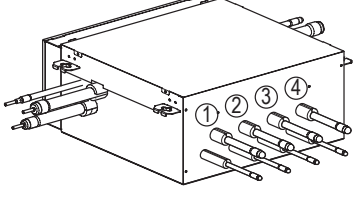
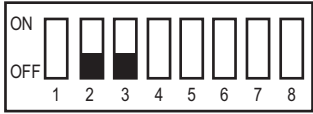
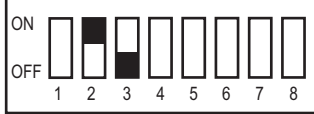

Setting Up the Heat Recovery Unit (Heat Recovery Systems Only)

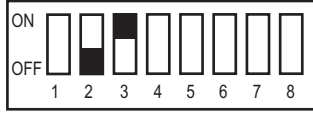
**Configure the Heat Recovery Unit Settings**

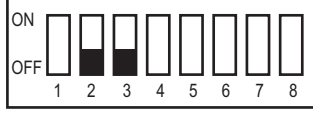
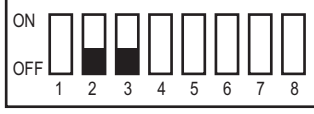
1. Identify how many ports are connected (see Table 57).
2. Group ports if necessary. If any connected indoor units are "large" capacity models (indoor units with >54,000 Btu/h capacity) two heat recovery ports must be "grouped" to serve a large capacity indoor using an inverted 'Y' branch.
3. Set DIP Switches as outlined in Tables 57 and 58.

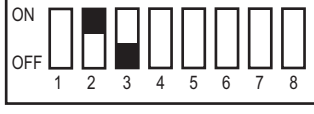
Table 69: Selecting the Heat Recovery Unit Model.

	 PRHR021A (Two [2] ports)	 PRHR031A (Three [3] ports)	 PRHR041A (Four [4] ports)
Factory Setting			
One port connected			
Two ports connected			
Three ports connected			
Four ports connected			

**Note:**

Each heat recovery unit has dip switches No. 2 and No. 3 factory set as shown above in initial setting.

- To use a PRHR021A for one port, cap off the second pipe, and set the dip switches on the heat recovery unit for "one port connected" as shown in the table above.
- To use a PRHR031A for two ports, cap off the third port, and set the dip switches on the heat recovery unit for "two ports connected" as shown in the table above.
- To use a PRHR041A for three ports, cap off the fourth port, and set the dip switches on the heat recovery unit for "three ports connected" as shown in the table above.
- To use a PRHR041A for two ports, cap off the third and fourth ports, and set the dip switches on the heat recovery unit for "two ports connected" as shown in the table above.
- Any unused port must be sealed with a brazed copper cap, not with a plastic cap.

Setting up the Heat Recovery Unit (Heat Recovery Systems Only)

Table 70: Valve Group Settings.

	Dip Switch Setting	Example
No Valve Group Control	<p>ON OFF 1 2 3 4 5 6 7 8</p>	<p>Indoor unit Indoor unit Indoor unit Indoor unit</p>
No. 1, 2 Valve Control	<p>ON OFF 1 2 3 4 5 6 7 8</p>	<p>Indoor unit Indoor unit Large capacity indoor unit</p>
No. 2, 3 Valve Control	<p>ON OFF 1 2 3 4 5 6 7 8</p>	<p>Indoor unit Large capacity indoor unit Indoor unit</p>
No. 3, 4 Valve Control	<p>ON OFF 1 2 3 4 5 6 7 8</p>	<p>Large capacity indoor unit Indoor unit Indoor unit</p>
No. 1, 2 Valve Control No. 3, 4 Valve Control	<p>ON OFF 1 2 3 4 5 6 7 8</p>	<p>Large capacity indoor unit Large capacity indoor unit</p>



Setting up the Heat Recovery Unit (Heat Recovery Systems Only)

**Note:**

If manual addressing, the heat recovery unit valve address and the central control address of its corresponding indoor unit should be set using the same number.

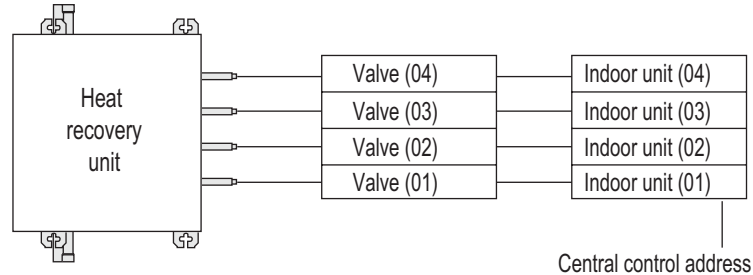

**SW01M / SW03M / SW04M DIP Switch and Tact Switch for Manual Heat Recovery Unit Valve Addressing**

Use to manually address the heat recovery unit valve.

**Normal Setting**

- Set the address of the heat recovery control unit valve to the central control address of the connected indoor unit.
  - SW01M: Selects the valve to address.
  - SW03M: Increases the ten (10) digit of the valve address.
  - SW04M: Increases the valve address by one (1).
- Prerequisite for manual valve addressing: The central control address of each indoor unit must be preset at its wired remote controller.

Table 71: Manual Valve Addressing.





<p>ON OFF 1 2 3 4</p> <p>SW01M</p>	Dip Switch No.	Setup
	No. 1	Manual addressing valve No. 1
	No. 2	Manual addressing valve No. 2
	No. 3	Manual addressing valve No. 3
	No. 4	Manual addressing valve No. 4
<p>SW03M</p>	SW03M	Increases the ten (10) digit of the valve address
<p>SW04M</p>	SW04M	Increases the valve address by one (1)

## Setting up the Heat Recovery Unit (Heat Recovery Systems Only)

### Zone Setting

- Set the address of the heat recovery control unit valve to the central control address of the connected indoor unit.
  - SW01M: Selects the valve to address.
  - SW03M: Increases the ten (10) digit of the valve address.
  - SW04M: Increases the valve address by one (1).
  - SW05M: Rotary switch.
- Prerequisite for manual valve addressing: The central control address of each indoor unit must be preset at its wired remote controller.

Table 72: Zone Setting.

 SW01M	Dip Switch No.	Setup
	No. 1	Manual addressing valve No. 1
	No. 2	Manual addressing valve No. 2
	No. 3	Manual addressing valve No. 3
 SW03M	SW03M	Increases the ten (10) digit of the valve address
 SW04M	SW04M	Increases the valve address by one (1)
 SW05M	SW05M	Manual addressing zoned indoor units

### Pressure (Leak) Test

Verify a pressure (leak) test has been performed and passed. If not, perform one now. Use medical grade dry nitrogen and pressure test the refrigerant piping system to a minimum of 550 psi for a period of 24 hours.

### Evacuate the Refrigerant Piping System

**Note:**

*The water source unit may be put in “vacuum mode.” Generally, using the vacuum mode feature does assist with the vacuum process and is not necessary if a vacuum pump is connected to all charging ports at the water source unit simultaneously as suggested herein. See the Technical Service Manual for this product for more information.*

**Note:**

*DO NOT apply power to any Multi V system device prior to performing a system evacuation. There is a possibility that EEV valves may close and isolate sections of the pipe system, Contact your LG Applied Rep champion or service technician for the procedure to reopen the EEV valves before evacuation.*

1. Release the Pressure Test dry nitrogen charge from all refrigerant pipes.
2. Verify ALL field installed isolation ball valves are OPEN (including those that are capped for future use).
3. Remove and discard the Schrader valve cores at the water source unit charging ports. This preventive step ensures that valves used after charging the system have not been subjected to the high pressure used during the Pressure Test.
4. Attach a 5/16” core removal tool equipped with ball valve and a fresh core to each charging port on the water source unit.
5. Check the vacuum pump(s) you intend to use and verify the oil in the sump is fresh and not contaminated.
6. Attach the vacuum pump(s) to each charging port simultaneously using high quality refrigerant vacuum hoses.
7. Perform a triple evacuation.
8. Achieve a micron gauge reading of less than 500 microns.
9. At 500 microns, valve off the charging port by closing the core removal tool ball valves.
10. Remove the vacuum hoses and pumps.
11. Leave the refrigerant piping system in a vacuum until the commissioning agent arrives and is satisfied with the micron gauge reading.

**Note:**

- *There is no danger in leaving the refrigerant piping system in a vacuum as all piping and equipment are dry and have never had oil in them.*
- *The system must be left in a vacuum until the Commissioning Agent arrives and verifies the quality of the evacuation process. If the evacuation procedure was not conducted properly, the system will likely malfunction and operate erratically. Significant costs may be incurred including but not limited to refrigerant reclaim, recycle, and replacement.*
- *Do not open the water source unit service valves and release the factory refrigerant charge until the commissioning agent authorizes to do so.*

### Vacuum for Water Source Systems

Vacuum the refrigerant piping system by connecting the vacuum pump to the service ports on the water source unit as shown in Figure 85 for heat pump systems and Figure 86 for heat recovery systems. Use a vacuum pump with a gauge that can evacuate to 500 microns, and vacuum with the service port valve closed. Never air purge with refrigerant.

1. Evacuate the system for two (2) hours, bringing the system up to 500 microns. After maintaining the system to 500 microns for more than one (1) hour, confirm that pressure has risen. If not, there may be moisture or a leak somewhere in the refrigerant piping system.
2. If the system has been evacuated for more than two (2) hours and it is suspected that moisture may be present (rainwater may have entered the piping if installation took a long time to complete, or if work occurred during a rainy season), pressurize to 14 psi (vacuum break) with nitrogen gas, and then vacuum again for one (1) hour to 500 microns. If the system cannot be evacuated to 500 microns within two (2) hours, repeat vacuum break. After maintaining the system in vacuum for one (1) hour, check the vacuum gauge to see if pressure has risen.

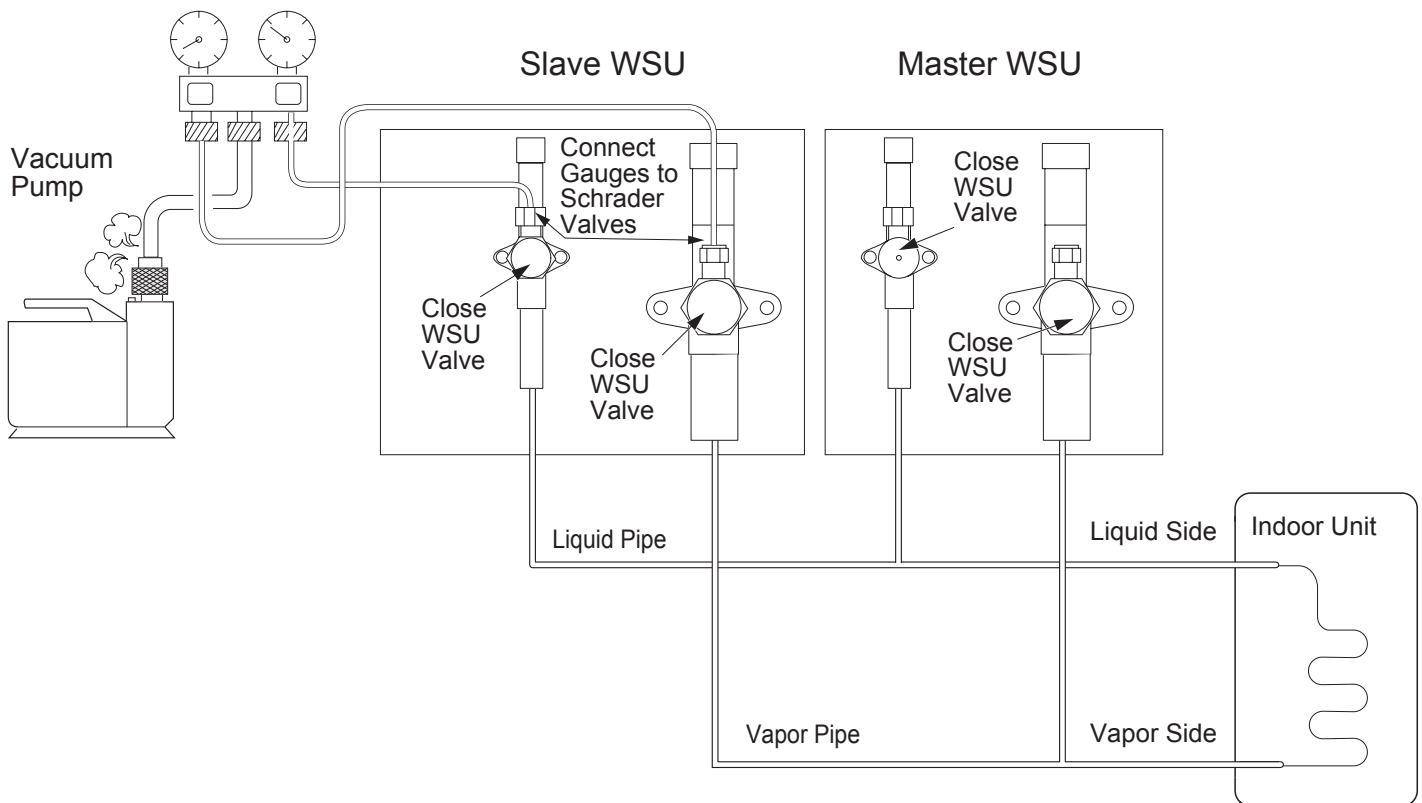

Figure 85: Heat Pump System Vacuum Configuration

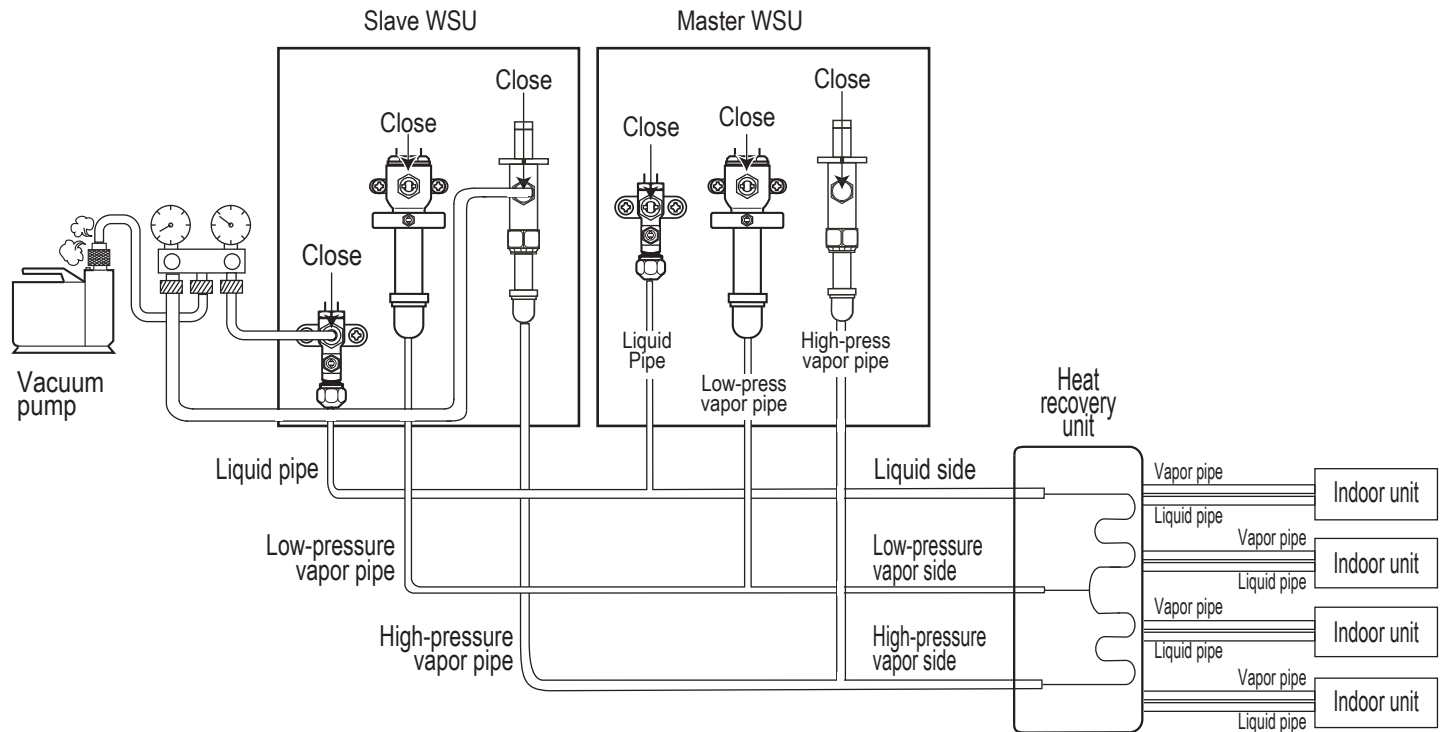

Figure 86: Heat Recovery System Vacuum Configuration

## Preparing the Water Circuit

1. Verify the specified waterside piping specialties such as temperature and pressure gauges, Pete's plugs, water balancing valves, shutoff valves, strainers, air vent(s), etc., were installed.
2. Verify the water circuit pump is operating correctly and the proper flow and temperature of water is provided to the water source unit.
3. Thoroughly flush the water circuit. Continually check and clean strainers as necessary. Continue flushing until strainers remain clean.
4. Purge all air from the water circuit. Check all auto or manual air valves installed.

### Note:

To prevent the heat exchanger from freezing, drain water out of the unit before charging the refrigerant.

## Balance the Water Circuit Flow Distribution

The water flow balancing contractor must complete their work prior to commissioning and verifying the water flow rate is within project specifications. Excessive or restricted water flow may impact the ability of the Commissioning Agent to successfully complete system commissioning. It is best if the water flow balancing is completed prior to initiating a request for a Commissioning Agent. Upon completion of the waterside balancing, the report should provide the maximum flow rate (GPM) at the water source unit.

### Note:

The Commissioning Agent is not responsible for setting the water flow rate, only to spot check. If a problem exists, request verification from the Test and Balance technician. If necessary, provide instruction to the technician on how to adjust the setting(s).

### Pre-commissioning Package Documents

Collect these documents before commissioning and have them available to the commissioning agent.

1. A copy of the refrigerant piping system(s) shop drawing(s) generated by LATS Multi V pipe design software.
2. A copy of the pipe fitter's pipe changes and field notes.
3. A verified copy of the "As-Built" LATS Multi V Project file (\*.mtv) that includes all changes noted by the pipe fitter(s) in item 2 of this list. Notes should include changes to the line lengths and # elbows used for each liquid line segment
4. A copy of a completed and verified Installation Checklist for the water source unit, indoor units, ERVs, Air Cleaners, and Control Devices. Correct any needing attention before continuing.
5. A copy of the water circuit control sequence of operation.
6. A water circuit flow balancing report.
7. A completed Pre-commissioning Device Configuration Worksheet.
8. A completed copy of the Pre-commissioning Checklist.
9. If an AC Smart Central Controller is provided and it is to be connected to the building network, record the IP Address on the Pre-commissioning Device Configuration Worksheet.

#### Optional, but Highly Recommended

It is always best if the air balance is completed prior to a request for a commissioning agent to insure the air volume delivered at each indoor unit is per project specifications. The commissioning agent is not responsible for setting the indoor unit fan speed or ensure the air volume delivered at each indoor unit is per project specifications. Excessive or restricted airflow may impact the ability of the commissioning agent to successfully complete system commissioning. Upon completion of the air balance, the report should include the adjusted indoor unit's fan speed (i.e., fan setting value) set by the Test and Balance technician to deliver cataloged air volume (CFM) at jobsite static pressure conditions.

### Initiate a Request for System Commissioning

Contact your LG Applied Representative's Project Manager or your account representative and request a Water Source System Commissioning. Provide all the documents listed in the "Pre-commissioning Package Documents" section above.

#### After Commissioning Has Been Requested

The commissioning agent may contact you to discuss specific job points, scheduled day(s) and expected duration. It is the contractor's responsibility to provide all of the necessary start-up labor, refrigerant, tools and test equipment needed to complete the process in the expected time frame. Please note that the commissioning agent's allotted time at your project DOES NOT include owner training. It is understood that the contractor is to request for a commissioning agent when all required project readiness points are complete; not based on an "expected" completion date. The contractor also acknowledges that they will assume all responsibility for costs incurred by the commissioning agent due to lack of readiness at the jobsite including but not limited to airfare, travel costs, transportation, shipping, labor, and tool costs.

The commissioning agent's schedule is usually very rigid, and may have no flexibility regarding duration. It also involves advance travel arrangements that may be impractical or impossible to change.

Freight Damage and Unit Replacements .....	Your LG Manufacturer Representative
Missing Parts .....	Your LG Manufacturer Representative
Received Wrong Water Source Unit Model.....	Your LG Manufacturer Representative
Installation, Startup, and Commissioning Technical Assistance .....	1-888-865-3026

To prevent heat exchanger damage and decreased system performance from scaling, the heat exchanger should be inspected once (1) per year or more often depending on the quality of the water and the water treatment program. For systems using an open tower, clean the heat exchanger annually or more often if local conditions require. Systems using closed cell towers need to be cleaned a minimum of once every five (5) years or more often if local conditions require.

**Yearly Inspection**

Inspect the plate heat exchanger once (1) a year, including:

- Water should be tested to see if it is within quality levels listed in the water circuit installation section of this manual.
- Strainer should be cleaned.
- Water flow rate should be checked.
- Water pressure, flow, and inlet / outlet water temperatures should also be checked.

**Five (5) Year Cleaning Procedure**

The heat exchanger is not designed to be disassembled and does not contain any replaceable parts. If the heat exchanger cannot be cleaned, the entire exchanger must be replaced.

- Heat exchanger cleaning solutions can include 5% diluted formic acid, citric acid, oxalic acid, acetate acid, phosphoric acid. Make sure the cleaning solution used does not include chemicals such as hydrochloric acid, sulfuric acid, nitric acid or calcium chloride that are corrosive to 316 stainless steel or ACR copper.
- Isolate the heat exchanger from the pipe system by closing the inlet / outlet ball valves and the drain pipe valve.
- Connect a hose to the service port, fill the heat exchanger with cleaning solution heated to 122°F–140°F, and circulate the solution for two (2) to five (5) hours using the solution tank pump. Procedure time may depend on the cleaning solution temperature, or the amount of scaling present. Watch for a change in cleaning solution color to determine how long the procedure should last.
- After circulating the cleaning solution, drain the heat exchanger, fill it with 1%–2% NaOH (Sodium Hydroxide) or NaHCO<sub>3</sub> (Sodium Bicarbonate), and circulate for 15 to 20 minutes to neutralize the system.
- Flush the heat exchanger with clean water and measure pH. Once the pH is within recommended levels, open the isolation valves, purge air from the system, and check unit operation.

Figure 87: Schematic of Heat Exchanger Maintenance.

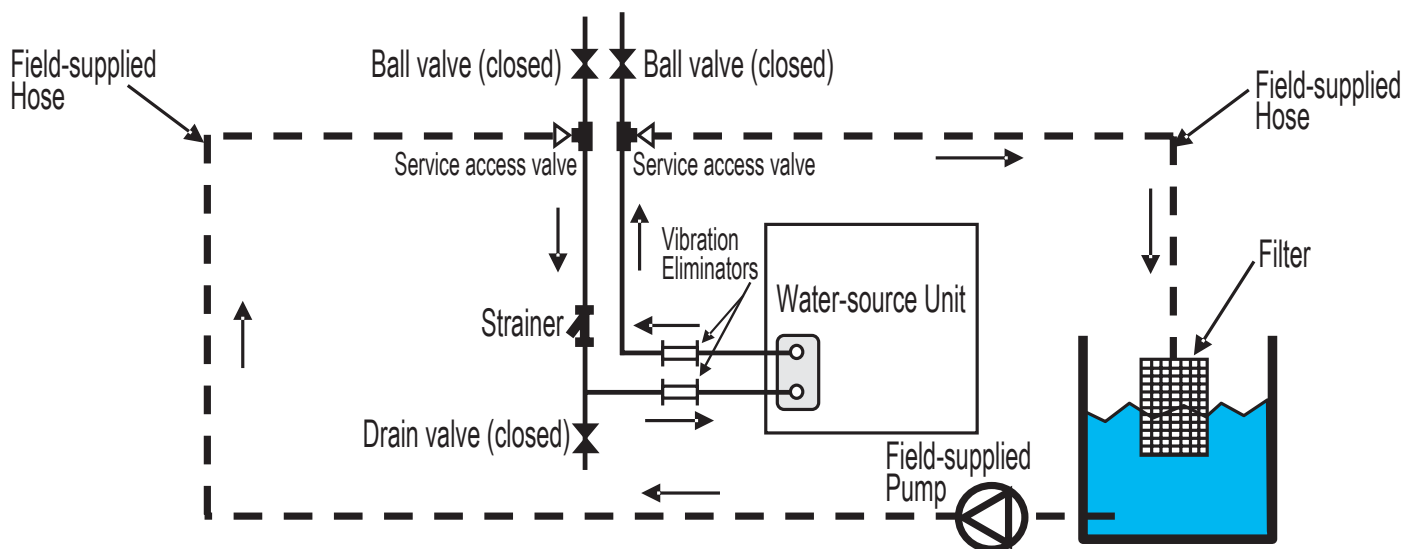

**Note:**

Before using a chemical solution to clean the heat exchanger, note its potential to corrode stainless steel or copper. Consult the chemical solution manufacturer for more information.

## General Maintenance Schedule

### 1. Water Quality Control

- The heat exchanger is not designed to be disassembled or cleaned, and does not contain any replaceable parts. If the heat exchanger is not usable, the entire exchanger must be replaced.
- To prevent corrosion or scaling, water quality must be controlled. Refer to the recommendations in Table 73 for minimum water quality requirements.
- Use only anti-corrosion agents or corrosion inhibitor additives that do not contain chemicals which damage or attack 316 stainless steel and ACR copper.
- Drain and replace the water / glycol mixture on a regular basis as needed. Frequency will depend upon the quality of the water treatment program used.

Table 73: Minimum Water Quality Requirements.

Basic Item	Closed Type System		Effect	
	Circulating Water	Supplemented Water	Corrosion <sup>1</sup>	Scale <sup>1</sup>
pH (77°F)	7.0 ~ 8.0	7.0 ~ 8.0	•	•
Conductivity (77°F) mS/m	Below 30	Below 30	•	•
Chlorine ions (mg Cl/ℓ)	Below 50	Below 50	•	
Sulfate ions (mg SO <sub>4</sub> <sup>2</sup> /ℓ)	Below 50	Below 50	•	•
Acid consumption (pH4.8) (mgCaCO <sub>3</sub> /ℓ)	Below 50	Below 50		•
Total Hardness (mg CaCO <sub>3</sub> /ℓ)	Below 70	Below 70		•
Calcium Hardness (mg CaCO <sub>3</sub> /ℓ)	Below 50	Below 50		•
Ionic-static silica (mg SiO <sub>2</sub> /ℓ)	Below 30	Below 30		•
Reference Item	Closed Type System		Effect	
	Circulating Water	Supplemented Water	Corrosion <sup>1</sup>	Scale <sup>1</sup>
Iron (mg Fe/ℓ)	Below 1.0	Below 0.3	•	•
Copper (mg Cu/ℓ)	Below 1.0	Below 0.1	•	
Sulfate ion (mg SO <sub>4</sub> <sup>2</sup> /ℓ)	Must not be detected	Must not be detected	•	
Ammonium ion (mg NH <sub>4</sub> <sup>+</sup> /ℓ)	Below 0.3	Below 0.1	•	
Residual chlorine (mg Cl/ℓ)	Below 0.25	Below 0.3	•	
Free carbon dioxide (mg CO <sub>2</sub> /ℓ)	Below 0.4	Below 4.0	•	
Stability index			•	•

<sup>1</sup>The "•" mark for corrosion and scale means that there is a possibility of occurrence.

### 2. Flow Rate Control

- The heat exchanger may freeze if water flow rate is insufficient.
- Check for a restricted strainer or if air is in the water piping system. Also measure the temperature and pressure difference between the inlet and outlet to verify the flow rate is per specifications.
- If the temperature and pressure difference is above the specified range, the flow rate is insufficient. Immediately cease system operation, locate the source of the problem and repair as needed. After any water circuit maintenance is preformed, always bleed air from the water system at all installed air vents.

### 3. Antifreeze Concentration Management

- Use the manufacturer's recommended type and amount of antifreeze. Do not use solutions with calcium chloride; these can corrode the heat exchanger.
- Maintain antifreeze levels. If there is a drop in the amount of antifreeze, the heat exchanger may freeze. Ensure that the antifreeze is not exposed to the atmosphere, and periodically measure antifreeze levels, adding as necessary.



Table 74: Minimum Maintenance Schedule.

Procedure	Period (Year)														
	1	2	3	4	5	6	7	8	9	10	11	12	13	14	15
Product operating condition	•	•	•	•	•	•	•	•	•	•	•	•	•	•	•
Heat exchanger cleaning (Wash)					•					•					•
Strainer cleaning	•	•	•	•	•	•	•	•	•	•	•	•	•	•	•
Water quality check	•	•	•	•	•	•	•	•	•	•	•	•	•	•	•
Refrigerant leakage check	•														•
Indoor unit filter cleaning	•	•	•	•	•	•	•	•	•	•	•	•	•	•	•

**Note:**

- This maintenance schedule is based on minimum requirements. Maintenance may need to be increased depending on operating conditions and/or water quality.
- Before cleaning the heat exchanger, make sure that the water pipe connections are tight so that chemical detergent does not leak. When cleaning the heat exchanger, close the valves so that chemical detergent does not penetrate into the pressure gauge, etc.
- Dilute the chemical detergent as recommended by the chemical supplier. Note that cleaning the heat exchanger is easier at the initial stages and becomes difficult after scaling has accumulated. In areas where the water quality is poor, cleaning is required more often.
- Because chemical detergent has a strong acid content, the system must be flushed thoroughly with water after cleaning.
- To verify the system has been properly cleaned, remove the hose at the heat exchanger and, using a flashlight or other bright light source, visually inspect the interior surfaces of the heat exchanger.
- After completing the visual inspection and determining the heat exchanger is clean—free of debris and mineral deposits and the cleaning chemicals have been thoroughly flushed—close the system, replace the water and purge the air from all air vents on the pipe system. Purge the air inside the water piping.
- Always check if the water supply is flowing normally and in the correct direction before operating the unit.

# LG MONITORING VIEW (LGMV) DIAGNOSTIC SOFTWARE



LG Monitoring View (LGMV) software allows real-time monitoring of Multi V Water IV system operating parameters. An industry-standard personal computer (PC) running LGMV connects to the main printed circuit board (PCB) of the water source unit through an LG interface cable. Two versions of LGMV are available: the Low version, which displays real-time parameters, and the High version, which displays the real-time parameters and the parameter targets. This software can be used to both commission new systems and troubleshoot existing systems. LGMV data can be recorded to a .csv file and emailed to an LG representative to assist with diagnostic evaluations. For detailed LGMV software information, contact your LG representative.

## Note:

Images on these pages are examples of LGMV screens. Actual screens may differ depending on the version of the software and the units installed.

## Recommended Minimum PC Configuration:

- CPU: Pentium® IV 1.6 GHz
- Main Memory: 1G
- Operating System: Windows® XP/Vista/7  
32 bit (recommended), 64 bit
- Hard Disk: 600 MB when operating
- MS Office 2003, 2007 (recommended)  
for select reporting functions

## LGMV Data Display

LGMV displays the following real-time data:

- Actual inverter compressor speed
- Target inverter compressor speed
- Actual superheat
- Target superheat (High version)
- Actual subcooler circuit superheat
- Target subcooler circuit superheat (High version)
- Main EEV position
- Subcooling EEV position
- Inverter compressor current transducer value
- Outdoor air temperature
- Actual high pressure/saturation temperature
- Actual low pressure/saturation temperature
- Suction temperature
- Inverter compressor discharge temperature
- Upper outdoor coil pipe temperature
- Lower outdoor coil pipe temperature
- Liquid line pipe temperature
- Subcooler inlet temperature
- Subcooler outlet temperature
- Four-way reversing valve operation indicator light
- Pressure graph showing actual low pressure and actual high pressure levels
- Error code display
- Operating mode indicator
- Target high pressure (High version)
- Target low pressure (High version)
- PCB (printed circuit board) version
- Software version
- Installer name
- Model number
- Site name
- Total number of connected IDUs
- Communication indicator
- IDU capacity
- IDU operating mode
- IDU fan speed
- IDU EEV position
- IDU room temperature
- IDU inlet pipe temperature
- IDU outlet pipe temperature
- IDU error code

Additional screens can be accessed by clicking on tabs on the main screen. Additional screens include:

1. Cycleview: Graphic of internal components including:
  - Compressors showing actual speeds
  - EEVs
  - IDUs
  - Temperature and pressure sensors
  - Four-way reversing valve
2. Graph: Full screen graph of actual high and low pressures and high and low pressure limits. A sliding bar allows viewing of previously recorded data.
3. Control FTN: Enables user to turn on IDUs in 1.8°F increments.

Figure 88: LGMV Real-time Data Screen.



Figure 89: LGMV Cycleview.

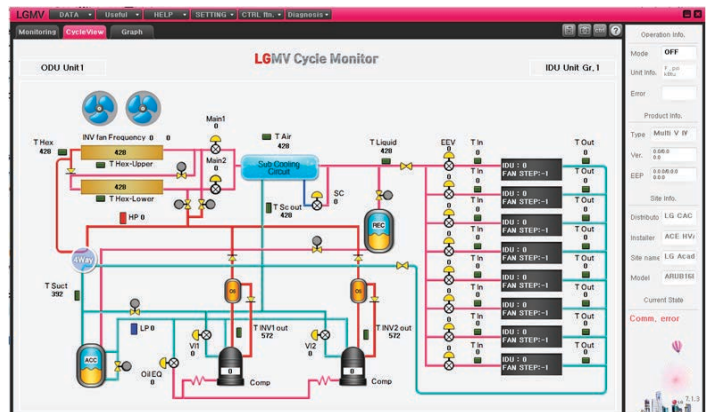

**Note:**

Images on these pages are examples of LGMV screens. Actual screens may differ depending on the version of the software and the units installed.

4. Useful Tab

- Unit Conversion: Converts metric values to imperial values.

5. Data

- Data Saving Start: Recording of real time data to a separate file created to be stored on the user's computer.
- Data Loading Start: Recorded data from a saved .csv file can be loaded to create an LGMV session.

6. Monitoring

- Electrical: The lower half of main screen is changed to show Inverter Compressor Amps, Volts, Power Hz, Inverter control board fan Hz.

Figure 90: LGMV Control Indoor Units Screen.

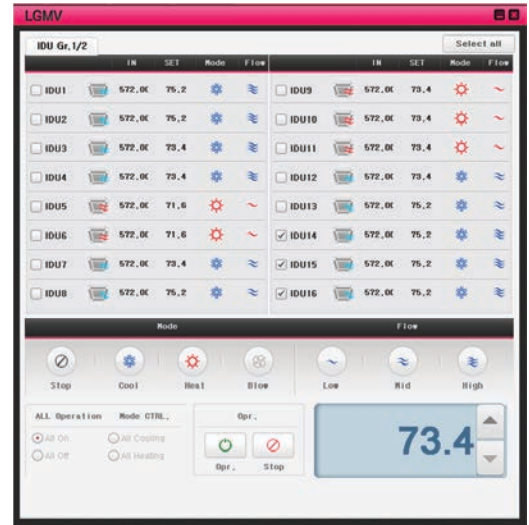

## Error Codes

LGMV software helps the service technician or commissioning agent to troubleshoot system operation issues by displaying error codes. These error codes are displayed on the upper right area of the LGMV main screen. For an overview of IDU error codes, refer to Table 75. For an overview of WSU error codes, refer to Table 76. For more detailed troubleshooting information, refer to the Multi V Water IV Service Manual.

Figure 91: Error Code Screen.

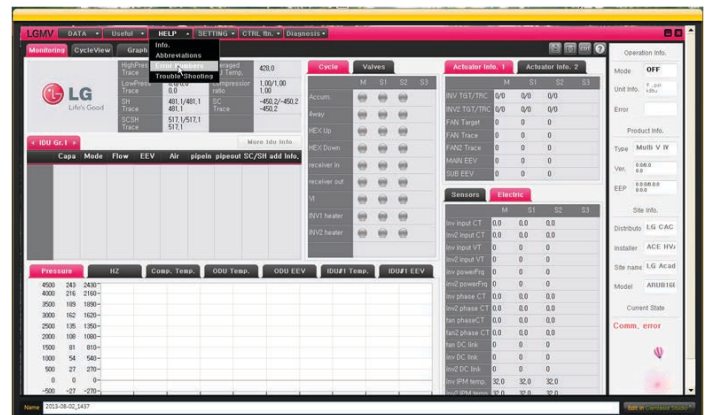

Error Codes

## Error Codes

- Error codes are displayed on the LED of indoor units, wired remote controllers, LED on the water source unit control board, and LG Monitoring View (LGMV) Diagnostic Software.
- Indicate different types of unit failures, assists in self-diagnosis and to track the frequency of occurrence.
- If two or more errors occur simultaneously, the lower error code number is displayed first.
- After error is resolved, the error code does not display.

## Indoor Unit Error Codes

Refer to Table 75 for a list of IDU error codes, descriptions of the codes, and possible causes. IDU error codes are two-digit numbers.

## Water Source Unit Error Code Display

Refer to Table 76 for a list of WSU error codes, descriptions of the codes, and possible causes. WSU error codes are three or four digit numbers.

### Note:

For detailed information on how to troubleshoot each error, see the Water Source Unit Service Manual on [www.lghvac.com](http://www.lghvac.com).

The first two or three numbers identify the error code. The fourth digit identifies the WSU frame that has the error. The fourth digit will be 1, 2, or 3 to identify which WSU unit has the error:

- 1 = Master WSU (or the only WSU in a single-frame system)
- 2 = Slave 1 WSU (in a two or three frame system)
- 3 = Slave 2 WSU (in a three frame system)

Example: **26–2** is error 26 on the slave 1 WSU. The dash indicates no digit displayed in the third LED position.

## Error Code Nomenclature Definitions

- MICOM: Non-volatile memory chip where unit setup information is stored.
- EPROM: Non-volatile memory chip where device identification, size, and factory defined default component operating parameters are stored.

Table 75: Indoor Unit Error Codes.

Error Code				Description	Possible Cause
0	1	–	–	Indoor unit air temperature sensor error	Indoor unit air temperature sensor disconnection or short circuit
0	2	–	–	Inlet pipe temperature sensor of indoor unit	Indoor unit pipe inlet temperature sensor disconnection or short circuit
0	3	–	–	Communication error between wired remote controller and indoor unit	Occurs when indoor unit communication signal is not received from the wired remote controller
0	4	–	–	Indoor unit drain error	Drain pump and float switch error
0	5	–	–	Communication error between WSU and indoor unit	When the indoor unit does not receive the outside communication signal continuously for 5 minutes or more
0	6	–	–	Indoor unit pipe outlet temperature sensor error	Indoor unit pipe outlet temperature sensor disconnection or short circuit
0	8	–	–	Hot water tank temperature sensor error	Hot water tank temperature sensor disconnection or short circuit
0	9	–	–	Indoor unit EEPROM error	Communication error between MICOM and EEPROM or when there is no indoor unit EEPROM data
1	0	–	–	Indoor unit BLDC motor feedback signal error	When motor connector is removed or defective
1	4	–	–	Hydro kit water flow switch error	Hydro kit water flow switch detect error
1	5	–	–	Hot water tank over temperature error	Hot water tank temperature sensor error or over temperature water detect
1	6	–	–	Hydro kit water pipe temperature sensor error	Hydro kit water pipe temperature sensor disconnection or short circuit
1	7	–	–	Hydro kit water pipe inlet temperature sensor error	Hydro kit water pipe temperature sensor disconnection or short circuit
1	8	–	–	Hydro kit water pipe outlet temperature sensor error	Hydro kit water pipe temperature sensor disconnection or short circuit

Table 76: Water Source Unit Error Codes.

Error Code				Description	Possible Cause
Number	WSU Frame				
2	0	0	1	Searching pipe error	Automatic valve addressing failure
2	1	-	1	Master WSU inverter compressor Intelligent Power Module (IPM) error	Master WSU inverter compressor drive IPM fault
2	1	-	2	Slave 1 WSU inverter compressor IPM fault	Slave 1 WSU inverter compressor drive IPM fault
2	1	-	3	Slave 2 WSU inverter compressor IPM fault	Slave 2 WSU inverter compressor drive IPM fault
2	2	-	1	Master WSU inverter board input over current (RMS)	Master WSU inverter board input current too high (RMS)
2	2	-	2	Slave 1 WSU inverter board input over current (RMS)	Slave 1 WSU inverter board input current too high (RMS)
2	2	-	3	Slave 2 WSU inverter board input over current (RMS)	Slave 2 WSU inverter board input current too high (RMS)
2	3	-	1	Master WSU inverter compressor DC link under-voltage	Master WSU DC voltage is not charged after Master WSU operating relay is turned on
2	3	-	2	Slave 1 WSU inverter compressor DC link under-voltage	Slave 1 WSU DC voltage is not charged after Slave 1 WSU operating relay is turned on
2	3	-	3	Slave 2 WSU inverter compressor DC link under-voltage	Slave 2 WSU DC voltage is not charged after Slave 2 WSU operating relay is turned on
2	4	-	1	High pressure switch	<ul style="list-style-type: none"> <li>Compressor maintenance by Master WSU high pressure switch</li> <li>Flow rate insufficient or Master WSU flow switch failure</li> </ul>
2	4	-	2	High pressure switch	<ul style="list-style-type: none"> <li>Compressor maintenance by Slave 1 WSU high pressure switch</li> <li>Flow rate insufficient or Slave 1 WSU flow switch failure</li> </ul>
2	4	-	3	High pressure switch	<ul style="list-style-type: none"> <li>Compressor maintenance by Master WSU high pressure switch</li> <li>Flow rate insufficient or Slave 2 WSU flow switch failure</li> </ul>
2	5	-	1	Master WSU input power voltage level high/low	Master WSU input power over or under voltage
2	5	-	2	Slave 1 WSU input power voltage level high/low	Slave 1 WSU input power over or under voltage
2	5	-	3	Slave 2 WSU input power voltage level high/low	Slave 2 WSU input power over or under voltage
2	6	-	1	Master WSU inverter compressor operation failure	Initial operation failure due to Master WSU inverter compressor error
2	6	-	2	Slave 1 WSU inverter compressor operation failure	Initial operation failure due to Slave 1 WSU inverter compressor error
2	6	-	3	Slave 2 WSU inverter compressor operation failure	Initial operation failure due to Slave 2 WSU inverter compressor error
2	8	-	1	Master WSU inverter DC link over voltage error	Inverter compressor off due to Master WSU inverter DC voltage too high
2	8	-	2	Slave 1 WSU inverter DC link over voltage error	Inverter compressor off due to Slave 1 WSU inverter DC voltage too high
2	8	-	3	Slave 2 WSU inverter DC link over voltage error	Inverter compressor off due to Slave 2 WSU inverter DC voltage too high
2	9	-	1	Master WSU inverter compressor over-current	Master WSU inverter compressor error or operating component (IPM) error operation
2	9	-	2	Slave 1 WSU inverter compressor over-current	Slave 1 WSU inverter compressor error or operating component (IPM) error operation
2	9	-	3	Slave 2 WSU inverter compressor over-current	Slave 2 WSU inverter compressor error or operating component (IPM) error operation

# ERROR CODE TABLES



Table 76: Water Source Unit Error Codes - continued

Error Code				Description	Possible Cause
3	2	-	1	Master WSU inverter compressor discharge temperature high	<ul style="list-style-type: none"> <li>Compressor turned off due to Master WSU inverter compressor discharge temperature too high</li> <li>Master WSU flow rate insufficient or flow switch error</li> </ul>
3	2	-	2	Slave 1 WSU inverter compressor discharge temperature too high	<ul style="list-style-type: none"> <li>Compressor turned off due to Slave 1 WSU inverter compressor discharge temperature too high</li> <li>Master WSU flow rate insufficient or flow switch error</li> </ul>
3	2	-	3	Slave 2 WSU inverter compressor discharge temperature too high	<ul style="list-style-type: none"> <li>Compressor turned off due to Slave 2 WSU inverter compressor discharge temperature too high</li> <li>Slave 2 WSU flow rate insufficient or flow switch error</li> </ul>
3	4	-	1	Master WSU high pressure too high	<ul style="list-style-type: none"> <li>Compressor turned off due to Master WSU high pressure too high</li> <li>Master WSU flow rate insufficient or flow switch error</li> </ul>
3	4	-	2	Slave 1 WSU high pressure too high	<ul style="list-style-type: none"> <li>Compressor turned off due to Slave 1 WSU high pressure too high</li> <li>Slave 1 WSU flow rate insufficient or flow switch error</li> </ul>
3	4	-	3	Slave 2 WSU high pressure too high	<ul style="list-style-type: none"> <li>Compressor turned off due to Slave 2 WSU high pressure too high</li> <li>Slave 2 WSU flow rate insufficient or flow switch error</li> </ul>
3	5	-	1	Master WSU low pressure too low	Compressor turned off due to Master WSU low pressure too low
3	5	-	2	Slave 1 WSU low pressure too low	Compressor turned off due to Slave 1 WSU low pressure too low
3	5	-	3	Slave 2 WSU low pressure too low	Compressor turned off due to Slave 2 WSU low pressure too low
3	6	-	1	Master WSU low pressure ratio	Master WSU pressure ratio is under limit
3	6	-	2	Slave 1 WSU low pressure ratio	Slave 1 WSU pressure ratio is under limit
3	6	-	3	Slave 2 WSU low pressure ratio	Slave 2 WSU pressure ratio is under limit
4	0	-	1	Master WSU inverter compressor CT sensor error	Master WSU inverter compressor current detection (CT) sensor disconnection or short circuit
4	0	-	2	Slave 1 WSU inverter compressor CT sensor error	Slave 1 WSU inverter compressor current detection (CT) sensor disconnection or short circuit
4	0	-	3	Slave 2 WSU inverter compressor CT sensor error	Slave 2 WSU inverter compressor current detection (CT) sensor disconnection or short circuit
4	1	-	1	Master WSU inverter compressor discharge temperature sensor error	Master WSU inverter compressor discharge temperature sensor disconnection or short circuit
4	1	-	2	Slave 1 WSU inverter compressor discharge temperature sensor error	Slave 1 WSU inverter compressor discharge temperature sensor disconnection or short circuit
4	1	-	3	Slave 2 WSU inverter compressor discharge temperature sensor error	Slave 2 WSU inverter compressor discharge temperature sensor disconnection or short circuit
4	2	-	1	Master WSU under-voltage sensor error	Master WSU under-voltage sensor disconnection or short circuit
4	2	-	2	Slave 1 WSU under-voltage sensor error	Slave 1 WSU under-voltage sensor disconnection or short circuit
4	2	-	3	Slave 2 WSU under-voltage sensor error	Slave 2 WSU under-voltage sensor disconnection or short circuit
4	3	-	1	Master WSU over-voltage sensor error	Master WSU over-voltage sensor disconnection or short circuit
4	3	-	2	Slave 1 WSU over-voltage sensor error	Slave 1 WSU over-voltage sensor disconnection or short circuit

Table 76: Water Source Unit Error Codes - continued

Error Code				Description	Possible Cause
4	3	-	3	Slave 2 WSU over-voltage sensor error	Slave 2 WSU over-voltage sensor disconnection or short circuit
4	4	-	1	Master WSU air temperature sensor error	Master WSU air temperature sensor disconnection or short circuit
4	4	-	2	Slave 1 WSU air temperature sensor error	Slave 1 WSU air temperature sensor disconnection or short circuit
4	4	-	3	Slave 2 WSU air temperature sensor error	Slave 2 WSU air temperature sensor disconnection or short circuit
4	5	-	1	Master WSU heat exchanger temperature sensor (A) fault	Master WSU heat exchanger temperature sensor (A) open or short
4	5	-	2	Slave 1 WSU heat exchanger temperature sensor (A) fault	Slave 1 WSU heat exchanger temperature sensor (A) open or short
4	5	-	3	Slave 2 WSU heat exchanger temperature sensor (A) fault	Slave 2 WSU heat exchanger temperature sensor (A) open or short
4	6	-	1	Master WSU suction temperature sensor error	Master WSU suction temperature sensor disconnection or short circuit
4	6	-	2	Slave 1 WSU suction temperature sensor error	Slave 1 WSU suction temperature sensor disconnection or short circuit
4	6	-	3	Slave 2 WSU suction temperature sensor error	Slave 2 WSU suction temperature sensor disconnection or short circuit
4	9	-	1	Master WSU IPM temperature sensor error	Master WSU IPM temperature sensor disconnection or short circuit
4	9	-	2	Slave 1 WSU IPM temperature sensor error	Slave 1 WSU IPM temperature sensor disconnection or short circuit
4	9	-	3	Slave 2 WSU IPM temperature sensor error	Slave 2 WSU IPM temperature sensor disconnection or short circuit
5	0	-	1	Master WSU input power phase loss	Master WSU has lost one of the phases of the three-phase power input
5	0	-	2	Slave 1 WSU input power phase loss	Slave 1 WSU has lost one of the phases of the three-phase power input
5	0	-	3	Slave 2 WSU input power phase loss	Slave 2 WSU has lost one of the phases of the three-phase power input
5	1	-	1	Over-capacity (Indoor unit capacity sum is excessive) connection	Excessive connection of indoor unit connection (combination ratio is exceeded)
5	2	-	1	Master WSU inverter controller communication error	Inverter controller signal is not received from the Master WSU inverter controller
5	2	-	2	Slave 1 WSU inverter controller communication error	Inverter controller signal is not received from the Slave 1 WSU inverter controller
5	2	-	3	Slave 2 WSU inverter controller communication error	Inverter controller signal is not received from the Slave 2 WSU inverter controller
5	3	-	1	Communication error between WSU controller and indoor unit	Indoor unit control signal is not received from the WSU inverter controller
5	7	-	1	Master WSU inverter controller communication error	Inverter controller signal not received by Master WSU controller
5	7	-	2	Slave 1 WSU inverter controller communication error	Inverter controller signal not received by Slave 1 WSU controller
5	7	-	3	Slave 2 WSU inverter controller communication error	Inverter controller signal not received by Slave 2 WSU controller
5	9	-	1	Series connection error	Connection error between WSUs
6	0	-	1	Master WSU inverter PCB EEPROM error	Master WSU inverter PCB EEPROM ACCESS error
6	0	-	2	Slave 1 WSU inverter PCB EEPROM error	Slave 1 WSU inverter PCB EEPROM ACCESS error
6	0	-	3	Slave 2 WSU inverter PCB EEPROM error	Slave 2 WSU inverter PCB EEPROM ACCESS error

# ERROR CODE TABLES



Table 76: Water Source Unit Error Codes - continued

Error Code				Description	Possible Cause
6	2	-	1	Master WSU inverter Insulated Gate Bipolar Transistor (IGBT) high temp error	Master WSU inverter IGBT temperature above 194°F
6	2	-	2	Slave 1 WSU inverter IGBT high temp error	Slave 1 WSU inverter IGBT temperature above 194°F
6	2	-	3	Slave 2 WSU inverter IGBT high temp error	Slave 2 WSU inverter IGBT temperature above 194°F
6	5	-	1	Master WSU inverter IGBT temperature sensor error	Master WSU inverter IGBT temperature sensor disconnection or short circuit
6	5	-	2	Slave 1 WSU inverter IGBT temperature sensor error	Slave 1 WSU inverter IGBT temperature sensor disconnection or short circuit
6	5	-	3	Slave 2 WSU inverter IGBT temperature sensor error	Slave 2 WSU inverter IGBT temperature sensor disconnection or short circuit
7	1	-	1	Master WSU PFC CT sensor error	Master WSU PFC CT sensor open or short
7	1	-	2	Slave 1 WSU PFC CT sensor error	Slave 1 WSU PFC CT sensor open or short
7	1	-	3	Slave 2 WSU PFC CT sensor error	Slave 2 WSU PFC CT sensor open or short
8	6	-	1	Master WSU EEPROM error	Communication error between Master WSU MICOM and EEPROM or EEPROM failure
8	6	-	2	Slave 1 WSU EEPROM error	Communication error between Slave 1 WSU MICOM and EEPROM or EEPROM failure
8	6	-	3	Slave 2 WSU EEPROM error	Communication error between Slave 2 WSU MICOM and EEPROM or EEPROM failure
8	8	-	1	Master WSU PFC PCB EEPROM error	Communication error between Master WSU master PFC and EEPROM or EEPROM failure
8	8	-	2	Slave 1 WSU PFC PCB EEPROM error	Communication error between Slave 1 WSU master PFC and EEPROM or EEPROM failure
8	8	-	3	Slave 2 WSU PFC PCB EEPROM error	Communication error between Slave 2 WSU master PFC and EEPROM or EEPROM failure
1	0	4	1	Slave WSU to Master WSU communication error	Master WSU does not receive communication signal from Slave WSU
1	0	4	2	Master WSU to Slave 1 WSU communication error	Master WSU communication signal not received by Slave 1 WSU
1	0	4	3	Master WSU to Slave 2 WSU communication error	Master WSU communication signal not received by Slave 2 WSU
1	1	3	1	Master WSU liquid pipe temperature sensor error	Master WSU liquid pipe temperature sensor disconnection or short circuit
1	1	3	2	Slave 1 WSU liquid pipe temperature sensor error	Slave 1 WSU liquid pipe temperature sensor disconnection or short circuit
1	1	3	3	Slave 2 WSU liquid pipe temperature sensor error	Slave 2 WSU liquid pipe temperature sensor disconnection or short circuit
1	1	4	1	Master WSU sub cool inlet temperature sensor error	Master WSU Sub cool inlet temperature sensor disconnection or short circuit
1	1	4	2	Slave 1 WSU sub cool inlet temperature sensor error	Slave 1 WSU Sub cool inlet temperature sensor disconnection or short circuit
1	1	4	3	Slave 2 WSU sub cool inlet temperature sensor error	Slave 2 WSU Sub cool inlet temperature sensor disconnection or short circuit



Table 76: Water Source Unit Error Codes - continued

Error Code				Description	Possible Cause
1	1	5	1	Master WSU sub cool outlet temperature sensor error	Master WSU Sub cool outlet temperature sensor disconnection or short circuit
1	1	5	2	Slave 1 WSU sub cool outlet temperature sensor error	Slave 1 WSU Sub cool outlet temperature sensor disconnection or short circuit
1	1	5	3	Slave 2 WSU sub cool outlet temperature sensor error	Slave 2 WSU sub cool outlet temperature sensor disconnection or short circuit
1	1	6	1	Master WSU oil sensor error	Master WSU oil sensor disconnection or short circuit
1	1	6	2	Slave 1 WSU oil sensor error	Slave 1 WSU oil sensor disconnection or short circuit
1	1	6	3	Slave 2 WSU oil sensor error	Slave 2 WSU oil sensor disconnection or short circuit
1	4	5	1	Master WSU main board to external board communication error	Master WSU main board communication signal is not received from the external board
1	4	5	2	Slave 1 WSU main board to external board communication error	Slave 1 main board communication signal is not received from the external board
1	4	5	3	Slave 2 WSU main board to external board communication error	Slave 2 main board communication signal is not received from the external board
1	5	1	1	WSU 4 way valve switch failure	WSU 4 way valve switch error
1	8	1	1	Master WSU water temperature sensor error	Master WSU water temperature sensor open/short
1	8	1	2	Slave 1 WSU water temperature sensor error	Slave 1 WSU water temperature sensor open/short
1	8	1	3	Slave 2 WSU water temperature sensor error	Slave 2 WSU water temperature sensor open/short
1	8	2	1	Master WSU communication error between external board MICOMs	Communication error between Master WSU external board main MICOM and sub MICOM
1	8	2	2	Slave 1 WSU communication error between external board MICOMs	Communication error between Slave 1 WSU external board main MICOM and sub MICOM
1	8	2	3	Slave 2 WSU communication error between external board MICOMs	Communication error between Slave 2 WSU external board main MICOM and sub MICOM

Table 77: Heat Recovery Unit Error Codes.

Error Code				Description	Possible Cause
2	0	1	C1–C16 <sup>1</sup>	HRU liquid pipe temperature sensor error	Sensor open/short <ul style="list-style-type: none"> <li>• Defective temperature sensor connection</li> <li>• Defective temperature sensor</li> <li>• Defective WSU PCB</li> </ul>
2	0	2	C1–C16 <sup>1</sup>	HRU sub-cooling inlet pipe temperature sensor error	Sensor open/short <ul style="list-style-type: none"> <li>• Defective temperature sensor connection</li> <li>• Defective temperature sensor</li> <li>• Defective WSU PCB</li> </ul>
2	0	3	C1–C16 <sup>1</sup>	HRU sub-cooling discharge pipe temperature sensor error	Sensor open/short <ul style="list-style-type: none"> <li>• Defective temperature sensor connection</li> <li>• Defective temperature sensor</li> <li>• Defective WSU PCB</li> </ul>
2	0	4	C1–C16 <sup>1</sup>	Communication error	Communication between WSU and HRU has failed

<sup>1</sup>Heat Recovery Unit number. Systems can have from 1 to 16 HRUs.

For detailed information on how to troubleshoot each error, see the Water Source Unit Service Manual on [www.lghvac.com](http://www.lghvac.com).

For detailed information on how to troubleshoot each error, see the Water Source Unit Service Manual on [www.lghvac.com](http://www.lghvac.com).

# LG Multi V Pre-Commissioning Device Configuration Worksheet



<b>Project Name:</b> _____ AC Smart Static IP address: _____	<b>Building ID:</b> _____ <b>System ID:</b> _____ Page # _____
Mech Contractor Company Name: _____ MEP Project Mng'r Name: _____ Ph# / Email: _____	
Pre-Com Tech Name/Ph#/email: _____	

## IDUs:

Unit Tag	Building Floor	Room ID	Type	Model	Serial #	Adjusted Fan Setting Value			System Address	Central Control Address	Group member ID or N/A if not in a group	Group Function M = Master S = Slave	Sensor Strategy (RA/ZC/Both)
						Low	Medium	High					

Due to our policy of continuous product innovation, some specifications may change without notification.  
 ©LG Electronics U.S.A., Inc., Englewood Cliffs, NJ. All rights reserved. "LG" is a registered trademark of LG Corp.



# INSTALLATION CHECKLIST



## Major Component Rough-In

Description	Check
All Multi V water source units are connected properly per local code and the product installation procedures.	
All literature and bagged accessories have been removed from the fan discharge (ducted and cassette model indoor units).	
Indoor units are installed, properly supported, and located indoors in a non-corrosive environment.	
Duct work installation completed (ducted indoor units only).	
Water source unit's gravity condensate drain line was connected and properly routed to a drain terminal.	

## Refrigerant Piping and Insulation

Description	Check
All refrigerant piping is copper	
Over 5/8 inches—Rigid ACR only.	
5/8 inches and under—Can use soft ACR.	
15% silver brazing material only.	
All refrigerant pipes and valves are insulated separately. Insulation butts up against the walls of the indoor units. No gaps or cracks. Insulation was not compressed at clamps and hangers.	
LG Y-branch fittings or headers were used as per LATS Multi V report.	
(Optional) Full port ball valves for all indoor units. (Schrader between the valve body and the indoor units.)	

## Brazing Practices

Description	Check
Use medical grade (there are 4 available) dry nitrogen for purging during brazing (constant 3 psi while brazing).	
Minimum 3/4", maximum 1" condensate piping installed on indoor units—material used is acceptable under local code. Insulated as necessary to prevent condensation.	

## Installation

(For more information on any procedure, refer to the detail provided in the Water Source and Indoor Unit Installation Manuals.)

### Refrigerant Piping

Description	Check
You must have in your possession a copy of the "As-Designed" LATS Multi V piping tree diagram. BEFORE ANY FIELD PIPE SIZE OR LENGTH CHANGES ARE MADE. PROPOSED CHANGES MUST BE FORWARDED TO THE DESIGN ENGINEER SO THAT THEY CAN INPUT THE CHANGES INTO LATS and RE-ISSUE A NEW LATS MULTI V PIPING TREE DIAGRAM. Installer must receive change authorization from the design engineer, because any change made requires the review of the entire tree diagram and verification that the change did not impact the size of piping segments in other parts of the system.	
All pipe materials were properly stored, capped, and clean. All burrs were removed after cutting and pipe ends were reamed before brazing.	
During refrigerant pipe installation, for each segment of pipe, a record was made of the pipe length (including expansion loops, offsets, double-back sections), and sizes, as well as the quantity and type of elbows used.	
All long runs of straight pipe were provided with expansion loops.	
Insure Y-branch fittings are installed within no more than $\pm 10^\circ$ of horizontal.	
Insure Y-branch fittings are installed within no more than $\pm 3^\circ$ of vertical.	
Insure all Header fittings are installed horizontal at an elevation above all connected indoor units.	
A torque wrench and backup wrench were used to tighten all flare connections.	
The back side of all flares were lubricated with a small drop of PVE refrigeration oil before tightening flare fittings.	
Ensure all field made flares are $45^\circ$ . Use LG factory-supplied flare nuts only.	
All pipe segments were properly supported and all wall penetrations were sleeved.	
All pipe insulation is not compressed at any point.	
Y-branch and headers fittings were properly supported per details provided in the Water Source Unit Installation Manual.	
Insure Y-branch fittings are installed in the correct direction. Flow is always from the single end to the double end.	
No oil traps, solenoid valves, sight glasses, filter driers, or any other unauthorized refrigerant specialties are present.	
(Optional) High quality R410A rated full port ball valves with a Schrader port were used at all indoor units and at will in the refrigerant piping network. (Recommended for serviceability.)	
Best practice—a minimum of 20" of straight pipe was installed between each elbow, and Y-branch or header fitting, and between two Y-branch fittings.	



## Water Piping

Description	Check
A No. 50 mesh (or better) minimum one inch diameter strainer is installed on the inlet pipe.	
Strainer service isolation valves, (optional bypass line and shutoff valve) provided on both ends of strainer. Strainer drain line installed.	
A balancing valve has been installed.	
A flow switch has been installed.	
Thermometers (or Pete's plugs) are installed on the inlet and outlet pipes.	
(Optional) Pressure gauges were installed on the inlet and outlet pipes.	
Piping is insulated properly per the design engineer's specifications.	
Pipes are properly supported. No lateral pressure is present on the inlet and outlet connections.	
The inlet and outlet pipes are connected at the water source unit. Water flow direction is correct (pipes are not reversed).	
Shutoff valves present at inlet and outlet of the water source unit.	

## Condensate Pump / Drain Installation

Description	Check
Indoor unit condensate drain pipes were installed correctly.	
All condensate vertical risers are equal to or less than 27'-1/2" from the bottom of the indoor unit.	
Indoor units with condensate pumps were leveled. Units with gravity drains were leveled or slightly canted toward the drain connection and are properly supported.	
Pumped condensate drain lines were properly connected (do not have traps, and connect to the top surface of the main drain line).	

## Power Wire and Communications Cables

Description	Check
Appropriate crimping tool used to attach ring or spade terminals at all power wiring and control cable terminations.	
Verify all ring and spade terminals are copper bearing in all communications daisy chains. Galvanized or nickel plated steel connectors were not used.	
Correct input voltage (208-230V or 460V as specified on water source unit nameplate) was connected to proper power input terminals of water source unit	
Ground wire was installed and properly terminated at the water source unit.	
The power supplied was clean with voltage fluctuations within specifications ( $\pm 10\%$ of nameplate).	
Power wiring to the water-source unit(s) was installed per all local electrical code requirements.	
Power wiring to each indoor unit was installed per all local electrical code requirements.	
Communications cable between the water source unit and indoor units was connected in a daisy chain configuration (i.e., single parallel chain). No "Star" or multiple parallel circuits. No cable splices or wire caps were used to connect communications cables.	
LG-supplied cable was used between each indoor unit and its zone controller. No cables were spliced and no wire caps are present.	
Communication type RS-485-BUS type. Communication cables are connected in a daisy chain configuration from unit to unit.	
All communications cables are a minimum of 18-Gauge, two conductor, stranded and shielded with insulation material per local code. Cable segment shields were tied together. Cable shield is grounded at the water source unit only.	
All power and control wires were properly separated using the recommended distance provided in the product installation manual.	
Only LG-supplied Y-cables and extension cables were used between indoor units.	
Flow switch communications cable has been properly terminated at the switch and the water source unit.	

# PRE-COMMISSIONING CHECKLIST



Job Name / Location \_\_\_\_\_ Tag # \_\_\_\_\_

Date: \_\_\_\_\_

Address: \_\_\_\_\_

\_\_\_\_\_

## Refrigerant Circuit Preparation

Description	Check
Using a copy of the LATS Multi V pipe design diagram, verify the sum of the indoor units nominal capacities connected to the piping system is between 50% and 130% of the water source unit's nominal capacity. If this rule is violated, the system will not start.	
Check all indoor units for power at the unit disconnect and at the indoor unit PCB board. (LED is lit.) DO NOT TURN ON THE UNIT using the ON/OFF button.	
Successful auto address routine is complete. All device addresses have been recorded on the Indoor Unit Device Configuration Worksheet.	
Insure all field-installed full-port ball valves are open.	
The piping system held a constant 550 psig pressure for a minimum of 24 hours with all isolation valves open.	
A triple system evacuation has been performed. Micron gauge reading held at a minimum of 500 for 24 hours with all isolation valves open and without the vacuum pump connected.	
Power was energized to the water source unit at _____ (time) on _____ day to power the compressor crankcase heater(s). (Must be at least 6 hours before commissioning.)	
The communications cable to the indoor units has been disconnected from the IDU (B) and IDU (A) terminals at the water source unit.	
None of the water source unit service valves have been opened during the installation and preparation of the system for commissioning. (If the valves were opened, the factory refrigerant charge has been released.)	

## Water Circuit Verification

Description	Check
System has been pressure tested to the designer's requirements. All unions and fittings are leak free.	
System has been filled with fluid, flushed, and all air has been purged from the piping circuit.	
Pump rotation direction is correct.	
Water flow enters on the water source unit inlet and leaves from the unit outlet.	
Pump and water source unit strainers are clean.	
Water balance has been completed.	
Proper water flow rate is present at each water source unit.	
Flow switch has been calibrated to trip at the water source unit's minimum flow requirement.	
Water has been properly treated with a rust inhibitor and fungicide chemicals.	
If required, an antifreeze chemical has been added to the water circuit.	



## Prepare Pre-commissioning Package Documents

Include	Check
1. A copy of the refrigerant piping system(s) shop drawing(s) generated by LATS Multi V pipe design software.	
2. A copy of the pipe fitter's pipe changes and field notes.	
3. A verified copy of the "As-Built" LATS Multi V Project file (*.mtv) that includes all changes noted by the pipe fitter(s) in Number 2. The tree diagram notes should include changes to the line lengths used for each liquid line segment	
4. A copy of a completed and verified Installation Checklist for the water source unit, indoor units, ERVs, Air Cleaners, and Control Devices. Correct any items needing attention before requesting commissioning..	
5. A copy of the air balance report showing proper airflow at all indoor units.	
6. A copy of the water circuit's control sequence of operation.	
7. A water circuit flow balancing report.	
8. A completed Pre-commissioning Device Configuration Worksheet.	
9. A completed copy of the Pre-commissioning Checklist (this checklist).	
10. If available, a list of IP addresses obtained from the building owner's IT department for each ACP, BacNet, LonWorks, AC Smart II, or AC Smart Premium devices.	

## Initiate a Commissioning Request

Description	Check
Verify this checklist and requirements herein have been met. Complete this checklist in its entirety BEFORE requesting Commissioning.	
Send all Pre-commissioning Package Documents to your LG Applied Representative.	

Contractor Name: \_\_\_\_\_

(Authorized Signature)

Address: \_\_\_\_\_

\_\_\_\_\_

Phone: \_\_\_\_\_ Date: \_\_\_\_\_

*\*This form must be completed and submitted to LG a minimum of three (3) weeks prior to final scheduling of any startup.*

*Note: If any of the above items are not complete at time of start-up, back charges will be assessed for additional costs.*

# PRE-COMMISSIONING CHECKLIST

Page 3



## Notes for the Commissioning Agent



**Notes for the Commissioning Agent**

Empty box for notes.

# REFRIGERANT CHARGE WORKSHEET



**Note:**

The system will stop operation due to excessive or insufficient refrigerant; therefore, always charge the unit properly. When servicing, always refer to any notes about system piping length and additional refrigerant amounts.

**System Refrigerant Charge Calculator (lbs.).**

System Tag or ID:		Job Name: _____				
		Project Manager: _____			Date: _____	
Line #	Description	Chassis I.D.	Size	Quantity	CF (Ref.) <sup>1</sup>	Total (lbs.)
1	Linear feet of 1/4" liquid line tubing <sup>2</sup>	—	—		0.015	
2	Linear feet of 3/8" liquid line tubing <sup>2</sup>	—	—		0.041	
3	Linear feet of 1/2" liquid line tubing <sup>2</sup>	—	—		0.079	
4	Linear feet of 5/8" liquid line tubing <sup>2</sup>	—	—		0.116	
5	Linear feet of 3/4" liquid line tubing <sup>2</sup>	—	—		0.179	
6	Linear feet of 7/8" liquid line tubing <sup>2</sup>	—	—		0.238	
7	Linear feet of 1" liquid line tubing <sup>2</sup>	—	—		0.323	
8	Wall Mounted + Art Cool Mirror	SE	7k to 15k		0.53	
9	Wall Mounted + Art Cool Mirror	S8, S5	18k to 24k		0.62	
10	1-Way Cassette	TJ	7k to 12k		0.44	
11	2-Way Cassette	TL	18k to 24k		0.35	
12	4-Way 2' x 2' Cassette	TR	5k to 7k		0.40	
13	4-Way 2' x 2' Cassette	TR	9k to 12k		0.55	
14	4-Way 2' x 2' Cassette	TQ	15k to 18k		0.71	
15	4-Way 3' x 3' Cassette	TN	9k to 15k		1.06	
16	4-Way 3' x 3' Cassette	TM	18k to 24k		1.41	
17	4-Way 3' x 3' Cassette	TP	24k to 28k		1.06	
18	4-Way 3' x 3' Cassette	TN	36k		1.41	
19	4-Way 3' x 3' Cassette	TM	42k to 48k		1.41	
20	High Static Ducted	BH	7k to 24k		0.57	
21	High Static Ducted	BG	15k to 42k		0.97	
22	High Static Ducted	BR	48k		1.37	
23	High Static Ducted	B8	76k to 95k		2.20	
24	Low Static Ducted, Low Static Ducted Bottom Return	B1, B3	7k to 15k		0.37	
25	Low Static Ducted, Low Static Ducted Bottom Return	B2, B4	18k to 24k		0.82	
26	Vertical / Horizontal Air Handling Unit	NJ	18k to 24k		1.04	
27	Vertical / Horizontal Air Handling Unit	NJ	30k		1.04	
28	Vertical / Horizontal Air Handling Unit	NJ	36k		1.57	
29	Vertical / Horizontal Air Handling Unit	NK	42k to 54k		2.00	
30	Ceiling Suspended	VJ	18k to 24k		0.77	
31	Convertible Surface Mount—Ceiling/Wall	VE	9k to 12k		0.22	
32	Floor Standing	CE (U)	7k to 15k		0.37	
33	Floor Standing	CF (U)	18k to 24k		0.82	
34	Heat Recovery Units: PRHR021A, PRHR031A, PRHR041A	—	—		1.1	
35	<b>ADDITIONAL Refrigerant Charge Required</b>					
	Sum of lines 1 – 34					
36	<b>Total WSU FACTORY Refrigerant Charge</b>					
	Sum of factory refrigerant charges for all WSUs in the system. Refer to Table 78 through Table 81 for WSU charge data.					
37	<b>TOTAL SYSTEM CHARGE</b>					
	Sum of Additional Refrigerant Charge Required (line 35) and Total WSU Factory Refrigerant Charge (line 36)					

<sup>1</sup>CF (Ref.) = Correction Factor for Refrigerant Charge.

<sup>2</sup>For refrigerant charge purposes, consider only the liquid line; ignore the vapor line(s).



Table 78: Total Heat Pump Water Source Unit (208-230V) Refrigerant Charge

Nominal Tons	Combination Model Numbers	Individual Component Model Numbers			Refrigerant Charge			
					Frame 1	Frame 2	Frame 3	Total
6.0	ARWN072BAS4	ARWN072BAS4	—	—	12.8	—	—	12.8
8.0	ARWN096BAS4	ARWN096BAS4	—	—	12.8	—	—	12.8
10.0	ARWN121BAS4	ARWN121BAS4	—	—	12.8	—	—	12.8
12.0	ARWN144BAS4	ARWN144BAS4	—	—	12.8	—	—	12.8
14.0	ARWN168BAS4	ARWN096BAS4	ARWN072BAS4	—	12.8	12.8	—	25.6
16.0	ARWN192BAS4	ARWN121BAS4	ARWN072BAS4	—	12.8	12.8	—	25.6
18.0	ARWN216BAS4	ARWN144BAS4	ARWN072BAS4	—	12.8	12.8	—	25.6
24.0	ARWN288BAS4	ARWN144BAS4	ARWN144BAS4	—	12.8	12.8	—	25.6
30.0	ARWN360BAS4	ARWN144BAS4	ARWN144BAS4	ARWN072BAS4	12.8	12.8	12.8	38.4
36.0	ARWN432BAS4	ARWN144BAS4	ARWN144BAS4	ARWN144BAS4	12.8	12.8	12.8	38.4

Table 79: Total Heat Pump Water Source Unit (460V) Refrigerant Charge

Nominal Tons	Combination Model Numbers	Individual Component Model Numbers			Refrigerant Charge			
					Frame 1	Frame 2	Frame 3	Total
6.0	ARWN072DAS4	ARWN072DAS4	—	—	12.8	—	—	12.8
8.0	ARWN096DAS4	ARWN096DAS4	—	—	12.8	—	—	12.8
10.0	ARWN121DAS4	ARWN121DAS4	—	—	12.8	—	—	12.8
12.0	ARWN144DAS4	ARWN144DAS4	—	—	6.6	—	—	6.6
14.0	ARWN168DAS4	ARWN168DAS4	—	—	6.6	—	—	6.6
16.0	ARWN192DAS4	ARWN192DAS4	—	—	6.6	—	—	6.6
20.0	ARWN240DAS4	ARWN144DAS4	ARWN096DAS4	—	6.6	12.8	—	19.4
24.0	ARWN288DAS4	ARWN168DAS4	ARWN121DAS4	—	6.6	12.8	—	19.4
28.0	ARWN336DAS4	ARWN168DAS4	ARWN168DAS4	—	6.6	6.6	—	13.2
32.0	ARWN384DAS4	ARWN192DAS4	ARWN192DAS4	—	6.6	6.6	—	13.2
40.0	ARWN480DAS4	ARWN192DAS4	ARWN144DAS4	ARWN144DAS4	6.6	6.6	6.6	19.8
48.0	ARWN576DAS4	ARWN192DAS4	ARWN192DAS4	ARWN192DAS4	6.6	6.6	6.6	19.8

Table 80: Total Heat Recovery Water Source Unit (208-230V) Refrigerant Charge

Nominal Tons	Combination Model Numbers	Individual Component Model Numbers			Refrigerant Charge			
					Frame 1	Frame 2	Frame 3	Total
6.0	ARWB072BAS4	ARWB072BAS4	—	—	12.8	—	—	12.8
8.0	ARWB096BAS4	ARWB096BAS4	—	—	12.8	—	—	12.8
10.0	ARWB121BAS4	ARWB121BAS4	—	—	12.8	—	—	12.8
12.0	ARWB144BAS4	ARWB144BAS4	—	—	12.8	—	—	12.8
14.0	ARWB168BAS4	ARWB096BAS4	ARWB072BAS4	—	12.8	12.8	—	25.6
16.0	ARWB192BAS4	ARWB121BAS4	ARWB072BAS4	—	12.8	12.8	—	25.6
18.0	ARWB216BAS4	ARWB144BAS4	ARWB072BAS4	—	12.8	12.8	—	25.6
24.0	ARWB288BAS4	ARWB144BAS4	ARWB144BAS4	—	12.8	12.8	—	25.6
30.0	ARWB360BAS4	ARWB144BAS4	ARWB144BAS4	ARWB072BAS4	12.8	12.8	12.8	38.4
36.0	ARWB432BAS4	ARWB144BAS4	ARWB144BAS4	ARWB144BAS4	12.8	12.8	12.8	38.4

Table 81: Total Heat Recovery Water Source Unit (460V) Refrigerant Charge

Nominal Tons	Combination Model Numbers	Individual Component Model Numbers			Refrigerant Charge			
					Frame 1	Frame 2	Frame 3	Total
6.0	ARWB072DAS4	ARWB072DAS4	—	—	12.8	—	—	12.8
8.0	ARWB096DAS4	ARWB096DAS4	—	—	12.8	—	—	12.8
10.0	ARWB121DAS4	ARWB121DAS4	—	—	12.8	—	—	12.8
12.0	ARWB144DAS4	ARWB144DAS4	—	—	6.6	—	—	6.6
14.0	ARWB168DAS4	ARWB168DAS4	—	—	6.6	—	—	6.6
16.0	ARWB192DAS4	ARWB192DAS4	—	—	6.6	—	—	6.6
20.0	ARWB240DAS4	ARWB144DAS4	ARWB096DAS4	—	6.6	12.8	—	19.4
24.0	ARWB288DAS4	ARWB168DAS4	ARWB121DAS4	—	6.6	12.8	—	19.4
28.0	ARWB336DAS4	ARWB168DAS4	ARWB168DAS4	—	6.6	6.6	—	13.2
32.0	ARWB384DAS4	ARWB192DAS4	ARWB192DAS4	—	6.6	6.6	—	13.2
40.0	ARWB480DAS4	ARWB192DAS4	ARWB144DAS4	ARWB144DAS4	6.6	6.6	6.6	19.8
48.0	ARWB576DAS4	ARWB192DAS4	ARWB192DAS4	ARWB192DAS4	6.6	6.6	6.6	19.8

For additional technical materials such as submittals, engineering manuals, service manuals, and catalogs, visit [www.lghvac.com](http://www.lghvac.com).

Freight Damage and Unit Replacements .....	Your LG Manufacturer Representative
Missing Parts .....	Your LG Manufacturer Representative
Received Wrong Water Source Unit Model.....	Your LG Manufacturer Representative
Installation, Startup, and Commissioning Technical Assistance .....	1-888-865-3026

*Inverter*



LG Electronics  
Commercial Air Conditioning Division  
4300 Northpoint Parkway, Suite 100  
Alpharetta, Georgia 30022  
[www.lghvac.com](http://www.lghvac.com)

LG Customer Information Center, Commercial Products  
1-888-865-3026 USA  
Follow the prompts for commercial A/C products.

IM\_MultiV\_WaterIV\_9\_18  
Supersedes: IM\_MultiV\_WaterIV\_5\_16  
IM\_MultiV\_WaterIV\_11\_15  
IM\_MultiV\_WaterIV\_6\_15  
IM-MultiV-WaterIV-02-15  
IM-MultiVWaterIV-06-14