



MORRIS GARAGES

Since 1924



 **HECTOR** |  **HECTOR**  

— THE INTERNET CAR —

OWNER'S MANUAL



MORRIS GARAGES  
Since 1924

- ◆ Do not use blower or infotainment system in engine off mode.
- ◆ Ensure door, hood and tail gate are properly locked.
- ◆ In DCT/CVT - Shift to **P** before switching off ignition.

---

Welcome to the world of MG!!!

Thank you for choosing MG Hector – India's first Internet Car

This manual will familiarize you with the operation and maintenance of your new vehicle. It will also provide you important safety information. Please do read it carefully and follow the recommendations. This manual is like a permanent part of your car. It would go a long way in ensuring a safe and trouble-free operation and running of your MG Hector.

In case of any query, please feel free to call our 24 hours Helpline at 1800 100 6464 or email us at: [customercare@mgmotor.co.in](mailto:customercare@mgmotor.co.in)

SAFE and HAPPY DRIVING

From

Team MG India



# Contents

<b>PREFACE</b> .....	8		
<b>KEYS, DOORS AND WINDOWS</b> .....	9-32		
<b>Keys</b> .....	10		
• Key-in Reminder*.....	11	• Electric Liftgate .....	17
• Remote Control.....	11	• External Liftgate Switch .....	18
• Vehicle Locating.....	11	• Internal Liftgate Switch .....	18
• Remote Window Lowering.....	11	• Liftgate Closing Switch.....	18
• Remote Opening of Panoramic Sunroof*	11	• Kick Type Electric Tailgate .....	19
• Activation of Door Lock and		• Anti-pinch Function of Liftgate.....	19
Anti-theft Mode.....	12	• Inductive Tailgate .....	20
• Door Unlock and Release of		• Liftgate Service Hole .....	21
Anti-theft Mode.....	12	• Passive Entry Passive Start (PEPS)	
• Lock Function Alarm.....	12	System*.....	21
• Automatic Locking of Door .....	13	• Passive Locking .....	22
• Battery Replacement.....	13	<b>Passive Unlocking / Locking</b>	
<b>Door Lock</b> .....	14	<b>of Liftgate</b> .....	22
• External Door Locking and Unlocking....	14	<b>Engine Hood</b> .....	23
• Internal Door Locking and Unlocking.....	15	• Opening Engine Hood.....	23
• External / Internal Door Opening.....	15	• Closing Engine Hood.....	23
• Child Safety Lock.....	16	<b>Outside Rearview Mirror</b> .....	24
• Central Door Lock System.....	17	• Adjusting Outside Rearview Mirror .....	24
• Door Lock Thermal Protection.....	17	• Electrically Folding	
<b>Doors</b> .....	17	Outside Rearview Mirror*.....	24
• Liftgate .....	17	• Automatically Folding	
		Outside Rearview Mirror*.....	24
		• Defrosting of Outside	
		Rearview Mirror*.....	25
		• Inside Rearview Mirror.....	25
		<b>Windows</b> .....	25
		• Power Window .....	25
		• Power Window Switch.....	26
		• Power Window Lock Button .....	27
		• Sunshade.....	27
		• Auxiliary Handrail .....	27
		<b>Sunroof*</b> .....	28
		<b>Power Sunroof*</b> .....	28
		<b>Sunvisor</b> .....	29
		• Sun Blind.....	30
		• Sunroof Tilting .....	30
		• Sunroof Sliding .....	30
		<b>SEATS AND PROTECTIVE</b>	
		<b>DEVICES</b> .....	33-54
		<b>Headrest</b> .....	34
		• Position.....	34
		• Height Adjustment.....	34
		<b>Front Seat</b> .....	34
		• Seat Position and Backrest	
		Normal Condition .....	34
		<b>Seat Position Adjustment</b> .....	35
		• Manual Adjustment Type*.....	35
		• Electric Adjustment Type*.....	35
		<b>Seat Backrest Adjustment</b> .....	36

## CONTENTS

• Manual Adjustment Type*.....	36	• ISOFIX.....	45	<b>Roof Rail.....</b>	<b>60</b>
• Electric Adjustment Type*.....	36	<b>Table of Vehicle Handbook Information on Child Restraint Systems .....</b>	<b>47</b>	• Load Information.....	60
• Ventilation Seat Control Button.....	36	<b>Air Bag System .....</b>	<b>48</b>	<b>INSTRUMENTS AND CONTROLS.....</b>	<b>61-102</b>
<b>Driver's Seat Height Adjustment.....</b>	<b>37</b>	• Air Bag Indicator .....	48	<b>Instrument Panel .....</b>	<b>62</b>
• Manual Adjustment Type*.....	37	<b>Air Bag Position .....</b>	<b>49</b>	<b>Controls .....</b>	<b>63</b>
• Electric Adjustment Type*.....	37	• Frontal Air Bag .....	49	• Horn.....	63
<b>Seat Backrest Adjustment and Folding .....</b>	<b>37</b>	• Side Air Bag* .....	49	• Steering Wheel Adjustment* .....	64
<b>Rear Seat .....</b>	<b>38</b>	• Side Curtain Air Bag .....	49	• Front Windshield Wiper and Washer* .....	64
• Rear Seat (5-Seat Model) .....	38	<b>STORAGE .....</b>	<b>55-60</b>	• Rear Windshield Wiper and Washer* .....	65
• Armrest.....	38	<b>Storage Box.....</b>	<b>56</b>	• Exterior Entertainment Power Outlet*.....	65
• Middle Row Seat .....	38	• Instrument Panel Right Storage Box.....	56	• Rear Accessory USB Power Outlet* .....	66
<b>7 Seat Variant.....</b>	<b>39</b>	• Instrument Panel Central Storage Box.....	56	• Driving Recorder USB Power Outlet .....	66
• Seat Backrest Adjustment and Folding.....	39	• Armrest Storage Box .....	56	• Rear Power USB Port.....	66
• Seat Overturn .....	39	• Glasses Box* .....	56	<b>Warning Lamps, Gauges and Indicators.....</b>	<b>67</b>
• Seat Backrest Folding.....	40	• Console Storage Box* .....	57	• Speedometer.....	67
• Seat Layout Diagram.....	40	• Glove Box.....	57	• Tachometer .....	67
<b>Seat Belt .....</b>	<b>40</b>	• Seat Pocket.....	57	• Fuel Gauge.....	67
• Wearing.....	41	• Cup Holder .....	57	• General Odometer.....	68
• Height Adjustment*.....	42	• Door Storage Groove and Armrest.....	58	• Small Odometer .....	68
• Unbuckle .....	42	• Rear Side Wall Storage Groove and Armrest.....	58	• Engine Coolant Temperature Gauge.....	68
• Middle Row / Rear Row Seat Belt.....	42	• Backrest Hook.....	58	• Type-I Trip Computer Display Screen .....	69
• Seat Belt Use During Pregnancy.....	43	• Luggage Compartment Cargo Cover*.....	59	• Adjustment Lever.....	69
<b>Child Seat .....</b>	<b>44</b>			• Mobile phone Wireless charging .....	70
• Child Restraint System Type.....	44				

<b>Type-II Trip Computer Display Screen</b> .....	71		
<b>Type-I Trip Computer Display Screen Switch</b> .....	77		
<b>Control Indicators</b> .....	79		
• Type-I Instrument Cluster .....	79		
• Type-II Instrument Cluster .....	81		
• Turn Signal Lamp / Hazard Warning Indicator .....	83		
• Engine Oil Pressure Too Low Warning Lamp .....	83		
• Charging System Warning Lamp .....	84		
• Coolant Temperature Too High Warning Lamp .....	85		
• Front Fog Lamp Indicator*.....	85		
• Rear Fog Lamp Indicator .....	85		
• Headlamp High Beam Indicator .....	86		
• Position Lamp Indicator.....	86		
• Engine Malfunction Indicator Lamp (MIL).....	86		
• ABS Fault Warning Lamp .....	87		
• EPS Fault Warning Lamp .....	88		
• Airbag Fault Warning Lamp .....	88		
• Brake System/EBD Warning Lamp.....	89		
• Engine Immobilizer System Indicator .....	90		
• Driver Fasten-Seat-Belt Warning Lamp .....	91		
		• Front Passenger Fasten-Seat-Belt Warning Lamp*.....	91
		• Fuel Level Too Low Warning Lamp .....	91
		• Electronic Parking Brake (EPB) Working Indicator* .....	92
		• Electronic Parking Brake (EPB) Fault Warning Lamp* .....	92
		• Automatic Vehicle Hold (AVH) Working Indicator* .....	93
		• Automatic Vehicle Hold (AVH) Fault Warning Lamp* .....	93
		• ESC Fault Warning Lamp .....	94
		• ESC OFF Indicator .....	94
		• Transmission Fault Warning Lamp*.....	94
		• Emergency Parking (EP) Indicator*.....	95
		• Cruise Control System Working Condition Indicator*.....	95
		• TPMS Fault Indicator*.....	96
		• Overspeed Warning .....	96
		• Vehicle - Start / Stop Fault Indicator.....	96
		• SCR (Selective Catalytic Reduction) .....	97
		• Diesel Particulate Filter Indicator .....	97
		• Fuel Water Indicator Light* .....	97
		• Engine Hood Open Indicator* .....	98
		• Glow Plug Indicator* .....	98
		• 48v System Failure Warning Light* .....	98
		<b>Reverse Sensor*</b> .....	99
		• Reverse Video Display*.....	100
		<b>Parking Assist System*</b> .....	101
		• 360 Degree Panoramic Parking Screen Assist*.....	102
		• Parking Image Assist during Reversing...	103
		<b>LIGHTING</b> .....	103-110
		<b>Outside Lighting</b> .....	104
		• Lighting Switches.....	104
		• High Beam .....	104
		• Automatic Headlamp ON/OFF .....	104
		• Headlamp Flashing .....	104
		• Automatic Wiping .....	105
		• Hazard Flasher .....	105
		• Turn and Lane Change Signal Lamp.....	105
		<b>Fog Lamp</b> .....	106
		• Steering Assist Lighting Function* .....	106
		• Front Fog Lamp*.....	106
		• Rear Fog Lamp.....	107
		• Stop Lamp .....	107
		• Day Running Lamp*.....	107
		• Headlamp Leveling.....	107
		• Headlamp OFF Delay.....	107
		• Lamp ON Reminder.....	107
		<b>Inside Lighting</b> .....	108
		• Front Reading Lamp .....	108
		• Rear Reading Lamp.....	108
		• Luggage Compartment Illumination Lamp .....	109

## CONTENTS

### AUDIO ENTERTAINMENT

#### SYSTEM.....111-114

##### Audio Control Buttons on Steering Wheel\*.....112

##### Driver Information and Entertainment.....113

- Navigator Upgrading\* .....114

#### HVAC ..... 115-126

##### Air Outlet .....116

##### Air Conditioning .....118

- Electronic Air Conditioning Control Panel .....118
- Temperature Control Key .....119
- Fan Control Key .....119
- Air Distribution Mode .....119
- Front Windshield Defrosting Key .....121
- Internal / External Circulation Mode Key .....121

##### Manual Air Conditioning ..... 122

- Control Panel.....122
- Temperature Control Knob .....123
- Fan Control Knob ..... 123
- Air Distribution Mode Button ..... 123
- Internal Circulation Mode Button.....123
- Rear Windshield Defroster Button\* 124
- Air Conditioning (A/C) Button.....124
- Cool Air .....125
- Warm Air .....125

- Ventilation.....126

- Rapid Defrosting and Defogging.....126

#### DRIVING AND CONTROLS ..... 127-156

##### Driving Instructions .....128

- Vehicle Control.....128
- Emergency Measures.....128

##### Start and Operation .....129

- Trial Run of New Vehicle.....129
- Mechanical Ignition Switch Position\* 130
- Engine START STOP Switch Position\* .....131
- Electronic Steering Column Lock\*.....132
- Engine Starting .....133
- Engine START STOP Function\*.....134
- Cruise Control System \*.....135
- Engine Immobilizer System .....136
- Parking .....137

##### Manual Transmission\* .....137

- Operation for Shifting Transmission with Six Drive Gears to Reverse (R) Gear .....138

##### Automatic Dual Clutch

##### Transmission (DTC) \* .....138

- Shifting .....139
- Gear .....139
- Gear Display.....140
- Vehicle Start .....141

- Automatic Upshift.....141

- Kick-down.....141

- Hill-start Hold Control.....141

- Run Downhill .....142

- Protection Mode .....142

- 48V Hybrid Power System\*.....143

- Situations of Auto Engine Start.....144

- Continuous Variable Transmission (CVT).....147

##### Brake .....147

- Anti-lock Brake System (ABS) .....148

- Electric Brake Force Distribution (EBD) System .....148

- Electronic Stability Control (ESC) System ..... 148

- ESC OFF Switch .....150

- Hill-start Hold Control (HHC) System\* .....150

##### Parking Brake.....151

- Mechanical Hand Brake\* ..... 151

- Electronic Parking Brake (EPB) \* ..... 152

- Automatic Vehicle Hold (AVH) \* ..... 154

##### Fuel.....155

- Fuel Suggestions .....155

- Fuel Filling .....156

### VEHICLE SERVICE &

### MAINTENANCE ..... 157-192



<b>General Information.....</b>	<b>158</b>		
• Accessories and Vehicle Retrofitting.....	158		
• Vehicle Storage.....	158		
<b>Driver Checklist .....</b>	<b>158</b>		
• Exterior .....	158		
• Interior .....	158		
<b>Engine Compartment.....</b>	<b>159</b>		
• 1.5T Engine .....	159		
• 2.0 Diesel Engine .....	160		
<b>Engine Oil .....</b>	<b>161</b>		
• Engine Oil Level Check.....	161		
• Engine Oil and Oil Filter Replacement.....	161		
<b>Coolant .....</b>	<b>162</b>		
<b>Brake and Clutch Fluid.....</b>	<b>163</b>		
• Brake / Clutch Fluid Adding.....	163		
• Auto Transmission Clutch Fluid Adding *.....	164		
<b>Transmission Fluid.....</b>	<b>165</b>		
• Transmission Fluid Leakage Check ....	165		
<b>Windshield Washer Solvent .....</b>	<b>165</b>		
<b>Diesel Exhaust Fluid (DEF) .....</b>	<b>166</b>		
<b>Windshield Wiper.....</b>	<b>172</b>		
<b>Air Filter .....</b>	<b>173</b>		
• Air Filter Cleaning.....	173		
<b>Drive Belt.....</b>	<b>173</b>		
		<b>Brake Pedal .....</b>	<b>173</b>
		• Brake Pedal Travel Check.....	173
		<b>Fuse .....</b>	<b>174</b>
		• Engine Compartment Fuse Box.....	174
		• Indoor Fuse Box Layout.....	175
		• Engine Compartment Fuse Box Layout.....	176
		<b>Lamp Bulb Replacement.....</b>	<b>177</b>
		<b>Wheels and Tyres .....</b>	<b>178</b>
		• Maintenance .....	178
		• Internal Tread Wear Indicator .....	179
		• Tyre Rotation.....	180
		• Winter Tyres .....	180
		• Tyre Chain.....	180
		<b>Spare Tyre, Jack and Tools.....</b>	<b>181</b>
		• Tool Kit.....	181
		• Spare Tyre .....	181
		• Jack Lifting Point.....	181
		• Tyre Replacement.....	182
		<b>Jump Start (Dead Battery) .....</b>	<b>184</b>
		<b>Vehicle Traction.....</b>	<b>186</b>
		• Emergency Trailer.....	187
		• Front Towing Hook .....	187
		• Rear Towing Hook.....	188
		<b>Getting Vehicle Out of Trap.....</b>	<b>189</b>
		<b>Vehicle Maintenance.....</b>	<b>189</b>
		• Cleaning Agent .....	189
		• Vehicle Interior Maintenance and Cleaning.....	190
		• Glass Surface .....	190
		• Vehicle Exterior Maintenance and Cleaning.....	191
		• Corrosion Prevention .....	192
		<b>TECHNICAL DATA .....</b>	<b>193-194</b>
		<b>Vehicle Identification .....</b>	<b>194</b>
		• Identification Number (VIN).....	194
		• Vehicle Identification Tag .....	194
		• Engine Identification Number .....	194
		<b>Vehicle Data .....</b>	<b>195</b>
		• Vehicle Tools.....	202
		<b>Delivery of your Vehicle.....</b>	<b>203-206</b>
		<b>MG Motor New Vehicle Warranty .....</b>	<b>207-213</b>
		<b>MG Roadside Assistance 24x7 .....</b>	<b>214-217</b>
		<b>Service Coupon .....</b>	<b>219-230</b>
		<b>Change of Ownership Record .....</b>	<b>231</b>
		<b>Maintenance Interval .....</b>	<b>232-234</b>
		<b>Maintenance Record Sheet .....</b>	<b>235-236</b>
		<b>MG Motor India Sales and Service Network.....</b>	<b>237-241</b>

## Preface

The vehicle is integrated with advanced technologies, safety, environmental protection and economy.

The Manual provides necessary information to help you drive your vehicle safely and effectively.

The driver shall always note that improper operation of vehicle may cause accidents and injury risks. Moreover, you shall comply with the requirements in laws and regulations of the country. If these requirements are different from those in the Manual, the requirements in the laws and regulations shall prevail.

The staff of MG Authorised Service Center have received professional trainings and can provide complete and satisfactory service for your vehicle. Please contact a nearby MG Authorised Service Center if your vehicle needs maintenance or repair. Please refer to the Subsection “Network details of MG Authorised Service Center” for details of Service Center Contact.

Please carry the Manual with your vehicle for review and reference at any time. If you want to resell the vehicle, please handover the Manual to the new owner along with the vehicle for use when needed.

## How to use the Manual

- The contents at the beginning of the Manual and each section are used for locating specific information.
- As for directional data such as front, rear, left and right, the driving direction shall be taken as the front.
- Some functions described in the Manual may not be configured for all models, and the Manual may introduce some devices / functions that are not installed on your vehicle.
- The Manual includes the latest information available at the time of printing the Manual. The Company has the full authorities to take charge of the amendment to and statements on the Manual and reserves the right to make changes to the product without further notice after the Manual is printed. Some of pictures in the Manual are illustrations used here only for your reference. Please refer to real objects.

## Prompts

<b>Note</b>
<b>The content marked with “Note” indicates matters need to be noted during vehicle operation. Ignoring such information may lead to wrong operation.</b>

<b>Warnings</b>
<b>The content marked with “Warnings” indicates risks of accidents or injuries. Ignoring such information may lead to injuries.</b>

<b>Caution</b>
<b>The content marked with “Caution” indicates possibility of vehicle damage. Ignoring such information may lead to vehicle damage.</b>

<b>Dangers</b>
<b>The content marked with “Dangers” indicates risks of fatal injuries. Ignoring such information may endanger lives.</b>

“\*”: asterisk behind a title or text

“\*\*” indicates that the equipment mentioned is optional, and your vehicle may not have such equipment. Please refer to the actual vehicle for vehicle configuration.

MG Motor India Pvt. Ltd. reserves the copyright of the Manual.

## Keys, Doors and Windows

<b>Keys</b> .....	<b>10</b>		
• Key-in Reminder*	11		
• Remote Control	11		
• Vehicle Locating	11		
• Remote Window Lowering	11		
• Remote Opening of Panoramic Sunroof*	11		
• Activation of Door Lock and Anti-theft Mode	12		
• Door Unlock and Release of Anti-theft Mode	12		
• Lock Function Alarm	12		
• Automatic Locking of Door	13		
• Battery Replacement	13		
<b>Door Lock</b> .....	<b>14</b>		
• External Door Locking and Unlocking	14		
• Internal Door Locking and Unlocking	15		
• External / Internal Door Opening	15		
• Child Safety Lock	16		
• Central Door Lock System	17		
• Door Lock Thermal Protection	17		
<b>Doors</b> .....	<b>17</b>		
• Liftgate	17		
• Electric Liftgate	17		
• External Liftgate Switch	18		
• Internal Liftgate Switch	18		
• Liftgate Closing Switch	18		
• Kick Type Electric Tailgate	19		
• Anti-pinch Function of Liftgate	19		
• Inductive Tailgate	20		
• Liftgate Service Hole	21		
• Passive Entry Passive Start (PEPS) System*	21		
• Passive Locking	22		
<b>Passive Unlocking / Locking of Liftgate</b> .....	<b>22</b>		
<b>Engine Hood</b> .....	<b>23</b>		
• Opening Engine Hood	23		
• Closing Engine Hood	23		
<b>Outside Rearview Mirror</b> .....	<b>24</b>		
• Adjusting Outside Rearview Mirror	24		
• Electrically Folding Outside Rearview Mirror*	24		
• Automatically Folding Outside Rearview Mirror*	24		
• Defrosting of Outside Rearview Mirror*	25		
• Inside Rearview Mirror	25		
<b>Windows</b> .....	<b>25</b>		
• Power Window	25		
• Power Window Switch	26		
• Power Window Lock Button	27		
• Sunshade	27		
• Auxiliary Handrail	27		
<b>Sunroof*</b> .....	<b>28</b>		
<b>Power Sunroof*</b> .....	<b>28</b>		
<b>Sunvisor</b> .....	<b>29</b>		
• Sun Blind	30		
• Sunroof Tilting	30		
• Sunroof Sliding	30		

**Keys****Type I****Type II****Type III**

Each new vehicle is provided with two keys. Please reserve one key for spare.

For the sake of safety, please keep the key number plate in a safe place to prevent from illegal key making.

Different models may be provided with different keys. Please refer to real key.

**Caution**

**Do not leave the key in the vehicle. Take the key with you when you leave the vehicle.**

**Note**

**If the key is lost, please contact to MG Authorised Service Center.**

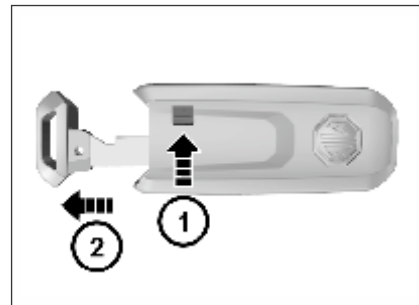
**Detachable Type**

As shown in the figure above, turn the release switch ① on the key first, and then pull out the mechanical key ②.

Plug back the mechanical key after use.

### Foldable Type

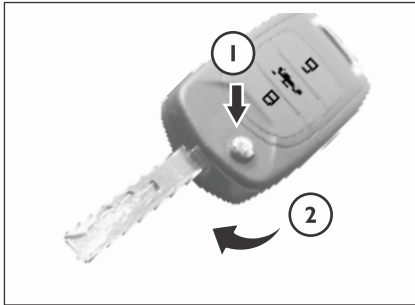

As shown in the figure, press the release button, and the mechanical key will pop up automatically.

Fold the mechanical key after use.

#### Key-in Reminder\*

If the driver's door is opened when the ignition key is at LOCK position and is not pulled out, the instrument will ring for prompt. The function reminds you to take the key with you when you leave the vehicle.

### Remote Control



The effective distance of remote control is about 15m without shielding. When the ignition key is plugged in the switch or the ENGINE START STOP Switch is at ACC or ON position, the remote control does not function.

 : Remote Lock Button. Press the button once to lock all doors after all doors are closed; the hazard warning lamp will flash twice, and the vehicle is at anti-theft state.

 : Remote Unlock Button. Press the button once to unlock all doors; the hazard warning lamp will flash once, Anti-theft state is released.

 : Liftgate Unlock Button. Press and hold for about 2s; open the liftgate, and the hazard warning lamp will flash once.

#### Note

The functioning range of the remote control may be different due to environmental reasons. Radio interference signals and barriers will affect the remote control functions.

#### Vehicle Locating

Press the remote lock button quickly for two times to activate the vehicle locating function, and the hazard warning lamp will flash for 20 times.

#### Remote Window Lowering

Press and hold the unlock button for about 2s to lower all windows automatically and in turn.

#### Remote Opening of Panoramic Sunroof\*

If the vehicle is configured with a panoramic sunroof, press the unlock button of the remote control for about 2s, the sun blind and sunroof will be opened automatically.

### Activation of Door Lock and Anti-theft Mode

1. Close all the windows.
2. Turn the ignition key to LOCK position and pull out the key (if mechanical ignition key is configured).
3. All passengers leave the vehicle.
4. Close all doors and the engine hood.
5. Press and release the remote lock button. All doors are locked. The hazard warning lamp will flash twice, and the immobilizer is activated.

As for a vehicle configured with ENGINE START STOP function, only when the ignition switch is at LOCK position can the transmitter activate the immobilizer system.

#### Note

**The anti-theft mode must be activated with the transmitter.**

- Warning sound  
Under the anti-theft state, when the unlock button on the transmitter is not pressed and any of the doors or liftgate is forced opened in an abnormal way (including use of a key), the system will

make the hazard warning lamp flash and emit warning sound.

- To stop warning sound  
Press and hold the lock, unlock or liftgate button on the transmitter for about 2s or turn the key to ON position to stop the warning sound; if not, the warning sound will be ended automatically after 30s, and the anti-theft mode is activated again. If the system fails to do so, it is recommended to have the system checked by the MG Authorised Service Center.

### Door Unlock and Release of Anti-theft Mode

1. Press the unlock button on the remote control once.
  - All doors are unlocked.
  - The hazard warning lamp flashes once.
  - The anti-theft state is released.
2. Press and hold the liftgate open button for 2s.
  - The liftgate is opened.
  - The hazard warning lamp flashes once.
  - The anti-theft state is released.

### Lock Function Alarm

The horn will buzz thrice and the hazard warning lamp will flash thrice to indicate that the doors are not locked successfully if the remote lock button is pressed or passive locking is conducted when the door lock conditions are not met. These situations include:

1. There is a door not closed (including liftgate)
2. The door lock is under thermal protection
3. The ignition switch is not at the LOCK position
4. The passive entry system (if configured) detects a legal key in the vehicle.

#### Caution

**Never leave a child or pet unattended in the vehicle. Otherwise, it may cause injuries or death due to high temperature in the vehicle.**

### Automatic Locking of Door

When all doors are closed and the vehicle speed exceeds 10 km/h, all doors will be locked automatically.

### Automatic Re-locking

With the key not in the ignition switch, the vehicle will activate re-locking if the alarm is disarmed but any of the doors and liftgate is not opened within 30s after the vehicle is under the armed state successfully.

### Ignition OFF Unlocking

When the doors are locked, they will be unlocked automatically if the ignition switch is turned from ON position to ACC or LOCK position.

### Remote Control

Each remote control has its own electronic code to prevent the doors being opened with other remote controls.

If the remote control is lost or stolen, please contact the MG Authorised Service Center to buy a new one as soon as possible. If you need to replace one or more remote controls, please bring with the existing remote control(s) when you go to the MG Authorised Service Center. When the MG Authorised Service Center matches the remote control

for replacement with the vehicle, the existing remote control shall also be matched with the new code. After the new remote control is coded electronically, the lost remote control will not unlock your vehicle. For Type I key, 3 transmitters can be configured at most each time; for Type II and III keys, 4 transmitters can be configured at most each time.

### Signal Transmission Autostop Function of Remote Control

The remote control has the signal transmission autostop function which can prevent unnecessary battery loss caused by misoperation and other reasons.

Long press any button on the remote control for over 10s, the remote control will stop transmitting signals automatically.

If the button is released, the signal transmission autostop function is deactivated.

### Fault

If the remote control cannot function normally, it may be caused by the following reasons:

- Out of remote control working range;
- Excessively low remote control battery;

- Interference by external environment and other high-power radio signals (such as base station and launch tower);
- Signal blocking by other barriers.

### Battery Replacement

Inside the key remote control, there is a lithium battery whose service life is 2 years generally. When the remote control distance is shortened gradually (i.e. must get closer to the vehicle), it indicates a low battery. The key battery cannot be charged. After the battery runs out, please go to the MG Authorised Service Center to have the battery changed. Battery model: CR2032.

### Note

**To ensure normal functioning of the remote control, please follow the following rules:**

- **Avoid dropping the remote control.**
- **Please do not place a heavy object on the remote control.**
- **Make sure the remote control is away from water or direct sunlight. If the remote control is soaked, please wipe with soft cloth.**

## Door Lock

### External Door Locking and Unlocking

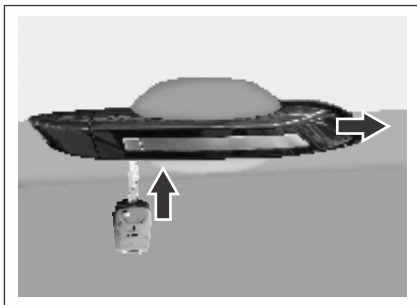

As shown in the figure above, the lockhole on the left front door external handle is hidden under the trim cover. The trim cover needs to be removed first if the key is used to open the door; for example, the remote control is lost or out of power.

Below the trim cover, there is a small hole. Plug the key in the hole and press inward; at the same time, prize up the trim cover outward to remove the cover.

For installation, press the trim cover inward to fasten it.

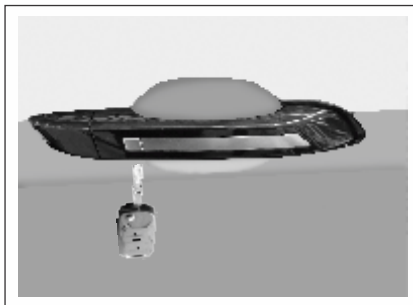

To lock a door outside of the vehicle with a key, plug the key and rotate it clockwise. Rotate the key counterclockwise to unlock the door.

#### Caution

**Do not leave a child or pet alone in the vehicle. Otherwise, severe casualty will be caused. The child may operate power windows or other control buttons or even drive the vehicle.**

**Do not leave the child with a key in the vehicle. Such behaviors may cause severe casualties.**



As shown in the figure, for type III, when the door is locked or unlocked with a key from outside the vehicle, the key piece is first passed through the hole of the key to rotate the key piece.

#### Note

**When you leave the vehicle unattended, you must lock all doors and liftgate and take the key with you. If the doors and liftgate are unlocked, the vehicle may be stolen. Please park your vehicle in an attended place. It is recommended not to leave valuables in the vehicle to prevent losses due to unforeseen circumstances.**



### Internal Door Locking and Unlocking

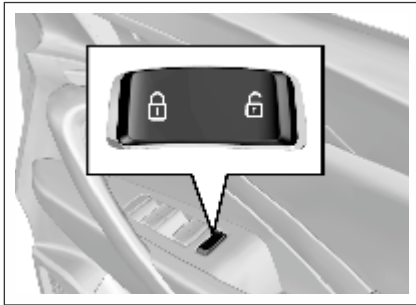

As shown in the figure, a central door lock switch is set on the middle of the instrument panel. To lock doors from inside, press the lock button on the central door lock switch.

To unlock doors from inside, press the unlock button on the central door lock switch.

If the lock button indicator is on, it means the doors are locked; if the indicator is off, it means the doors are unlocked.

### External / Internal Door Opening

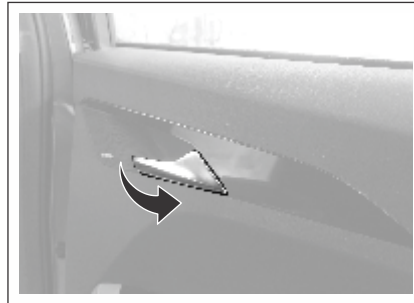
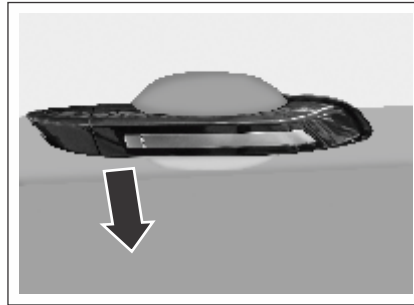

To open doors from inside or outside, unlock the doors first, and pull the external or internal door handles.

When the doors are locked, pulling the internal door handle twice can open the doors.

A child shall sit on the rear seat, and the door shall be locked with the child safety lock.

### Door Locking Method in Case of Vehicle Outage

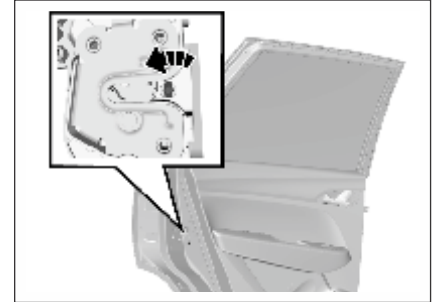

In case of vehicle outage (for example, the battery is out of power or its positive and negative poles are disconnected), the central door lock system does not function, and you need to lock side doors manually one by one.

As shown in the figure above, open the right front door and two rear doors, and find the internal knobs of locks (not the knob of child safety lock).

Rotate the knobs outward with a key, and close the doors. At last, pull the external handles to ensure that the doors are locked. At this time, please pull the internal handle once first if you want to open the door.

For the left front door, please plug the key in the external door handle and rotate the key clockwise to lock the door. Please refer to the content in the Subsection “External Door Locking and Unlocking”.

#### Note

**If there is noise while opening/closing doors or driving, apply lubricating grease on the door catches and hinges.**

### Child Safety Lock

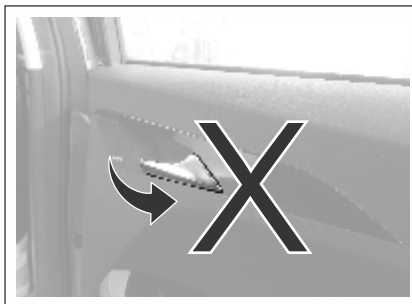

The rear doors are equipped with child safety locks.

The function of the child safety lock is to prevent passengers (especially children) from pulling the door handle to open the rear door.

#### Note

**The two rear doors are equipped with a child safety lock respectively. They function separately and must be activated manually and respectively.**

#### Note

**When the child safety lock is activated, do not attempt to pull the internal door handle to open the door. Otherwise, the door handle may be damaged.**

### To activate the child safety lock:

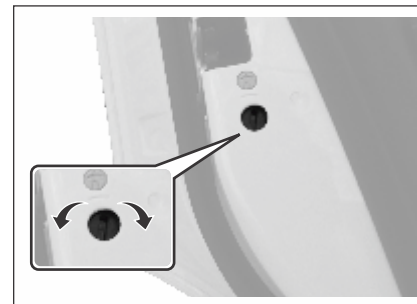

1. Open the rear door that you want to lock.
2. Find the child safety lock hole on the door edge and near the middle position.
3. Plug the key and rotate as per the arrow to the lock position.

When the child safety lock is activated, you need to pull the external door handle to open the door. To deactivate the child safety lock, please plug the key and rotate to the unlock position.

### Central Door Lock System

The central door lock system enables you to lock and unlock all doors with the remote control or the central door lock switch from inside.

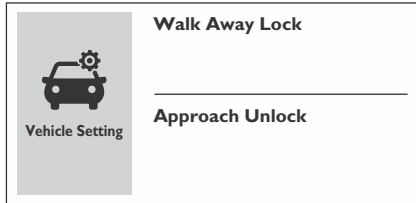
**Walk Away Lock / Approach Unlock\***

The Central Lock can also be operated by Walk Away Lock\* / Approach Unlock\* function. This function can be activated/deactivated from Head Unit. The vehicle automatically locks if you move away by more than 1 metre (vehicle ignition off & all doors close).

If you come within 1 metre range of vehicle (Center lock condition) the vehicle will get unlocked automatically provided you have a valid smart key.

**Door Lock Thermal Protection**

If the doors are unlocked / locked for over 10 times within 8s, the locks will be prohibited for 10s to protect them.

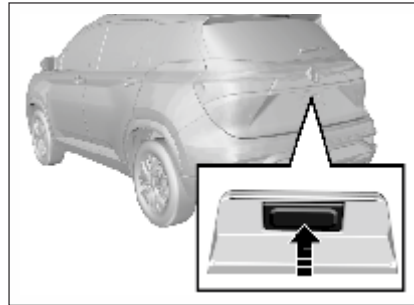
**Doors****Liftgate****External Liftgate Switch**

As shown in the figure, the liftgate release switch is above the liftgate license plate.

When the liftgate is to be opened, firstly, unlock the door, and then press the switch to unlock the liftgate, and open the liftgate.

According to the vehicle configuration, for the vehicles equipped with PEPS, you can directly carry the remote key to approach the liftgate, and press the switch to open the liftgate when the vehicle is locked.

**Liftgate Opening with Remote Key**

Press the remote key liftgate opening key for about 3s to unlock the liftgate when the engine is shut down.

To lock the liftgate, you need to close it and then lock it.

**Electric Liftgate\***

Before opening the liftgate, make sure that the vehicle stops, the gear is in parking gear, and the handbrake is pulled to avoid any damage.

For AT model, you can operate the liftgate in Gear P.

**Warning**

**Make sure that your and other persons' bodies are out of the opening range of the liftgate, your or other persons' hands and other body parts are out of the closing range of the liftgate to avoid any personal injury during liftgate opening or closing.**

### External Liftgate Switch

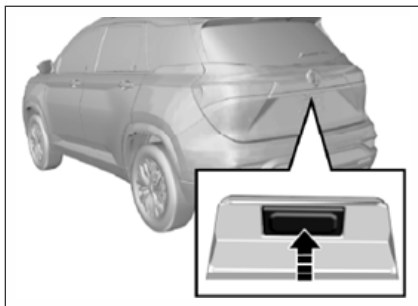

Firstly, unlock the vehicle, and press the switch. The liftgate automatically opens after two prompt tones. When the liftgate is to be closed, press the switch. The liftgate automatically closes after two prompt tones. The locking sound and two flashes of hazard warning lamp represent that the liftgate is closed and locked.

### Internal Liftgate Switch



Press the switch. The liftgate automatically opens after two prompt tones. When the liftgate is to be closed, press the switch. The liftgate automatically closes after two prompt tones. The locking sound and two flashes of hazard warning lamp represent that the liftgate is closed and locked.

#### Caution

**Before driving, please make sure that the liftgate is closed and locked. When leaving the vehicle, make sure that the liftgate is closed and locked, and the vehicle is locked.**

### Liftgate Closing Switch

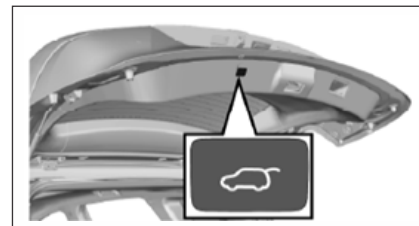

In the liftgate open state, press the liftgate closing switch, as shown in the figure. The liftgate automatically closes after two prompt tones. The locking sound and two flashes of hazard warning lamp represent that the liftgate is closed and locked.

During liftgate opening or closing, press this switch shortly. The liftgate will stop at the present position.

Setting of liftgate opening height: Adjust the opening height slowly manually after the liftgate is open. Press this switch for 3s after adjustment, and hear a prompt tone to end the setting. The subsequent liftgate opens to this height to stop.

You can also pull the liftgate to close with hands. When a certain speed is reached, the liftgate will enter the electric closing mode.

### Kick Type Electric Tailgate\*

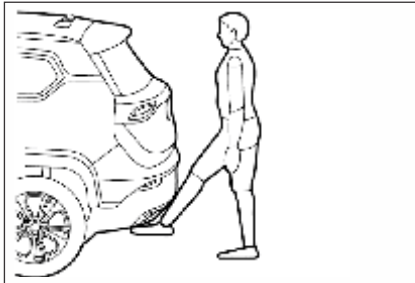

In the unlocked state of the door, stand behind the tailgate, use your instep to reach below the rear license plate position, and then retract it to complete a correct triggering action. After the two beeps sound, the tailgate opens or closes slowly.

When you close the tailgate, you hear a lock sound and the hazard warning light flashes twice, indicating that the tailgate is closed and locked.

With the door locked, if you have a key on your body, you can kick and open and close the tailgate directly.

#### Note

**The vehicle should be in locked condition while washing. The tailgate may open by underbody jet pressure / bucket flush.**

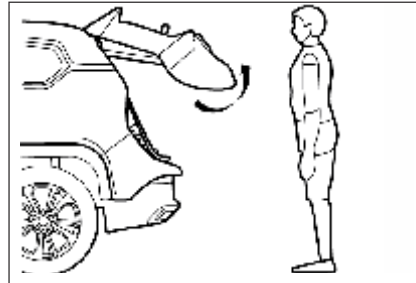

### Anti-pinch Function of Liftgate

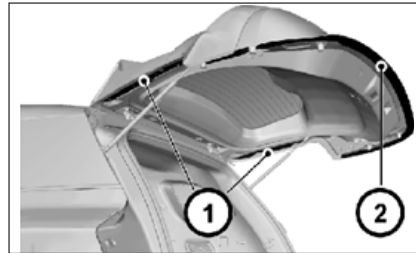

1. During liftgate closing, when any obstacle (such as finger) touches the anti-pinch strip in the zone, as shown in Figure ①, it triggers the anti-pinch function. The liftgate opens reversely to the preset stopping point.

2. During liftgate closing, when any obstacle (such as personnel) with stronger resistance is in the resistance anti-pinch zone, as shown in Figure ②, the liftgate enters the anti-pinch mode. The liftgate opens reversely to the preset stopping point.

#### Note

**For the anti-pinch function of the liftgate, a better anti-pinch cannot be realized at every position. The position closer to the liftgate hinge has a stronger anti-pinch force. Please keep your finger or other body parts away from the range of movement to avoid any personal injury.**

### Liftgate Antiplay

Before the liftgate is not completely locked, if the anti-pinch strip is triggered for 3 times, then the liftgate enters antiplay mode. The liftgate stops moving, and the switch is invalid. Please close the liftgate manually.

## Inductive Tailgate\*

The inductive Tailgate can be opened without touching the vehicle.

### How to use the Inductive Tailgate

The tailgate can be opened with no-touch activation satisfying all the conditions below.

1. The power supply of the vehicle is in the OFF
2. The speed is less than 2km or the vehicle's gearbox is in P gear
3. Driver side and Tailgate Door locked
4. The legal key is near the Tailgate

### Automatic Opening

The hazard warning lights will beep 2 times and flash 1 time and tailgate will slowly open.

### Automatic Closing

If the Tailgate is closed, there will be 2 beeps. After all the doors are locked, there will be 2 double flashes.

### Detect and Alert

The Tailgate operates if the smart key is detected within 50 ~ 100 cm from the tailgate.

The alert stops at once if the smart key is positioned outside the detecting area during the Detect and Alert to customer.

If you are positioned in the detecting area 50 ~100 cm behind the vehicle carrying the vehicle key, the hazard warning lights will blink for about 3 seconds to alert you the smart key has been detected and the tailgate will open.

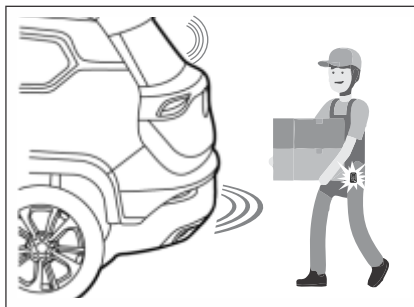

### Warning

**Do not approach the detecting area if you do not want the tailgate to open. If you have unintentionally entered the detecting area and the hazard warning lights and beep starts, leave the detecting area after checking the tailgate is in closed condition.**

### Liftgate Service Hole

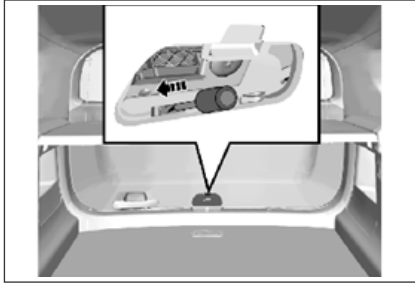

If other liftgate opening methods are invalid, the liftgate can be opened for service as per the following steps:

1. Fold the rear seat backrests, and get to the trunk.
2. Open the trim cover outside the liftgate lock, as shown in the figure above.
3. Insert a very small straight screwdriver into the rightmost end of the slot and move the lever in the slot leftward. The liftgate is opened when an unlock sound is heard.

### Caution

If the operation is correct, but the liftgate cannot be opened and closed normally with qualified conditions to open and close the electric liftgate, it is recommended to drive to the nearest Aftersales Service Center for repair.

### Passive Entry Passive Start (PEPS) System\*

High-configured models are equipped with PEPS system. You can lock or unlock the doors conveniently only by taking the remote control key with you and getting to the certain ranges of the front doors or liftgate. You can lock or unlock remotely without taking your key out from your pocket.

### Passive Entry

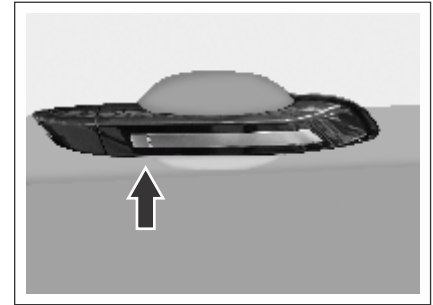

When the doors are locked and the ignition switch is at LOCK position, bring a legal key and get close to the front door handle (within 1.2 m); press the button on the handle, and the system will certify with the key. Once certified successfully, the system will unlock all doors. The hazard warning lamp flashes once.

### Passive Locking

When all doors are closed and the ignition switch is at LOCK position, bring a legal key and get close to the front door handle (within 1.2 m); press the button on the handle, and the system will certify with the key. Once certified successfully, the system will lock all doors. The hazard warning lamp flashes twice.

The system will send warning prompt, the horn will buzz thrice and the hazard warning lamp will flash thrice to indicate that the doors are not locked when you press the button on the door handle in case of the following situations:

1. There is a door not closed;
2. The ignition switch is not at LOCK position;
3. There is a key in the vehicle.

Check one by one, and then lock again.

#### Warning

**When opening the liftgate, make sure that all body parts are not within the opening range after hearing a prompt tone of opening, to avoid any personal injury during liftgate opening.**

### Passive Unlocking / Locking of Liftgate

#### Passive Unlocking

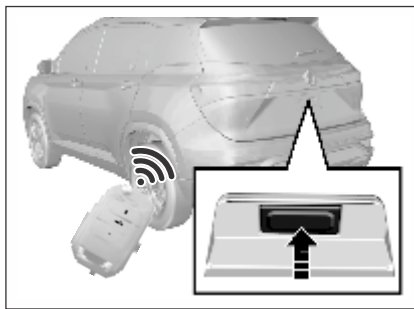

When the doors are locked and the ignition switch is at LOCK position, bring a legal key and get close to the liftgate (within 1.2 m); press the liftgate release switch, and the system will certify with the key. Once certified successfully, the system will unlock the liftgate, and the liftgate pops open.

If the doors are already unlocked, the liftgate can be opened by pressing the liftgate release switch directly (unnecessary to bring the key and get close to the liftgate).

#### Passive Locking

If the doors are locked, when the liftgate is closed, the system will search automatically whether there is a legal key in the vehicle. If there is no legal key in the vehicle, the liftgate will be locked automatically. The hazard warning lamp flashes twice. If there is a key in the vehicle, the system will send warning prompt, the horn will buzz thrice and the hazard warning lamp will flash thrice; the four side doors will be unlocked automatically. Please take away the key in the vehicle, and lock the doors again.

If the doors are unlocked, the liftgate can only be locked after closing the liftgate and locking the doors. Please remember to lock the doors.

#### Caution

**Before driving, please make sure that the liftgate is closed and locked.**

#### Note

**If the remote control battery is low, the passive entry / locking function may fail, and you can use the mechanical key to lock / unlock doors. Please replace the remote control battery as soon as possible.**



## Engine Hood

### Opening Engine Hood



1. Pull the engine hood release handle on the left lower side of the instrument panel.

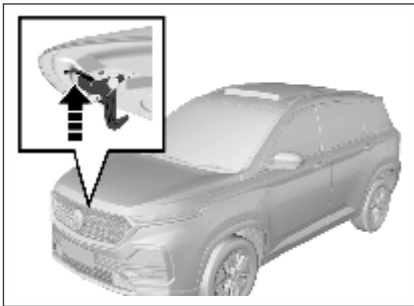

2. After the engine hood is opened slightly, stretch out the hand to the lower side of the engine hood front edge. Pull the engine hood release handle upward as shown in the figure to open the engine hood completely.

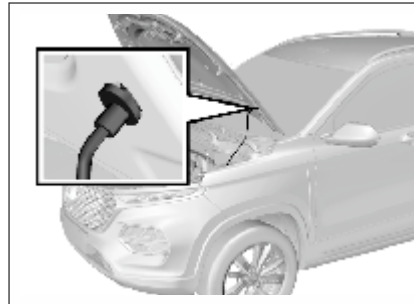

3. Separate the engine hood prop rod from the fixing clamp. Plug the free end of the prop rod in the slot.

### Closing Engine Hood

1. Support the engine hood to prevent it from closing, and take the prop rod out from the slot. Then, fix the rod in the fixing clamp.

2. Make sure that your or other persons' hands or other body parts are away from the engine compartment, engine hood and vehicle body edges.
3. Slowly drop the engine hood, and release it when the engine hood front edge is about 30 cm vertically from the top cross member of the water tank to let it fall freely.
4. Always check and confirm that the engine hood is locked in place.

### Caution

- Pull the engine hood front edge before driving to make sure that the engine hood is locked.
- Do not pull the engine hood release handle when the vehicle is moving.
- Do not drive the vehicle when the engine hood is open. If the engine hood is open, the driver's sight will be blocked.

Driving when the engine hood is open may cause a collision accident, damaging your vehicle or other properties or leading to casualties.

## Outside Rearview Mirror

Please check the visual field of all rearview mirrors before driving.

### Adjusting Outside Rearview Mirror

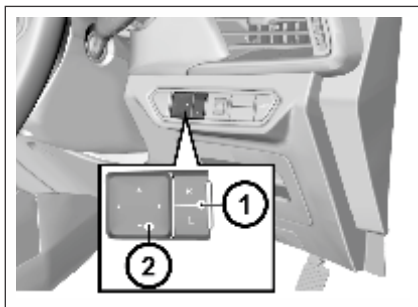

The power outside rearview mirror adjustment switch is on the left side of the instrument panel. Adjust the outside rearview mirror as per the following steps:

1. Select the rearview mirror to be adjusted. Press the “L” or “R” on the selector switch to adjust the left or right outside rearview mirror.
2. Press the buttons (△) around the setting pan to adjust the selected rearview mirror upward, downward, leftward and rightward.

3. After adjustment, recover the selector switch to non-pressed state (both ends not pressed).

### Electrically Folding Outside Rearview Mirror\*



Press the electric folding button to fold the outside rearview mirror automatically. Press the button once again, and the mirror will be unfolded automatically.

### Automatically Folding Outside Rearview Mirror\*

The outside rearview mirror will be folded automatically when the doors are locked. It will be unfolded automatically when the doors are unlocked.

If the electric folding button is pressed, the outside rearview mirror will not be unfolded automatically when the doors are unlocked.

### Deactivating Automatic Folding Function of Outside Rearview Mirror\*

In frosty weather, the outside rearview mirror and its spindle may be frozen in folded state, and the mirror cannot be unfolded. That will affect your driving. Therefore, we suggest you deactivate the automatic folding function of the outside rearview mirror temporarily in icy winter to let the mirror maintained in unfolded state.

Method: Enter the Setting Mode → Auto ORVM and set to “OFF”. Thus, the outside rearview mirror will not be folded automatically when the doors are locked.

### Notes to Electrical Folding of Frozen Outside Rearview Mirror

If the outside rearview mirror and its spindle are frozen, please remove the freeze first, and use the electric folding/unfolding functions. For example, if the mirror is frozen after the vehicle is parked outdoors for a night in winter, please remove the freeze first, and use the remote control or the passive entry button to unlock doors. Then, the outside

## Windows

### Power Window

When the ignition switch is at ON position, you can control the power window with the power window switch on the door armrest panel. You can also use the combination switch on the driver's side to control other power windows.

The windows can also be controlled with the power window switches within 30s after the ignition switch is turned from ON position to ACC or LOCK position or the key is pulled out.

#### Caution

**Children may operate the power window and may get stuck by the window when they operate it.**

**Do not leave a key or an unattended child in the vehicle.**

**Misoperation of the power window may cause casualties.**

### Inside Rearview Mirror

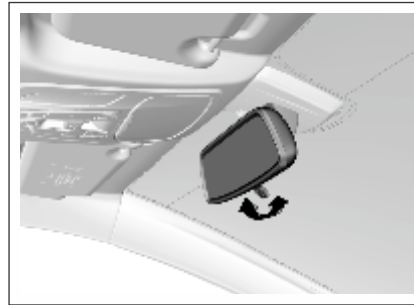

Adjust the rearview mirror to an appropriate angle manually. The rearview mirror of some models has anti-dazzling function which can reduce the dazzling effect from vehicles behind at night. Turn the switch at the rearview mirror bottom forward to activate the anti-dazzling mode. Please remember to turn the switch back at day time.

#### Note

**The anti-dazzling mode will reduce the vision clarity behind the vehicle. Please drive carefully.**

rearview mirror will be unfolded smoothly. If the freeze is not removed, the freeze will hinder the movement of the rearview mirror, damaging the mirror.

If the outside rearview mirror glass is frozen, please remove the freeze first, and then use the defrosting function for auxiliary heating and deicing. If the freeze is not removed, the freeze will hinder the movement of the rearview mirror while adjusting the mirror, causing damage to the mirror.

### Folding

To ensure the pedestrian's safety, the outside rearview mirror can be folded forward or backward from its normal mounting position under sufficient impact force. It can be moved and reset manually.

### Defrosting of Outside Rearview Mirror\*

The outside rearview mirror of some models is configured with defrosting function. Press the rear defrost button on the A/C control panel for defrosting. Refer to the content of the rear defrost button in the Chapter "HVAC".

## Power Window Switch

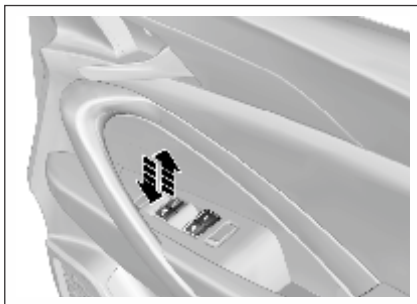

To raise the window, pull upward the switch.  
To lower the window, press down the switch.  
When the window reaches the desired position, release the switch.

### Caution

**If an occupant stretch his / her body out of the vehicle, he/she may be hit by objects passing by.**

**Do not stretch any body part out of the vehicle.**

### One-button Lowering of Driver's Side Power Window

The driver's side power window has the one-button lowering function. Press the switch to the bottom and release, and the window will be lowered to the fully-open position automatically. To stop lowering the window, pull upward the button and release (short pull is ok).

### One-button Raising of Driver's Side Power Window\*

The driver's side power window of some models has the one-button raising function. To close the window, pull upward the switch to the top and release, and the window will be raised automatically to the fully-close position. To stop raising the window, press down the button and release (short press is ok).

### Anti-pinch Function of Driver's Side Power Window\*

The power window that has the one-button rising function also has the anti-pinch function to reduce pinching injuries. The power window will be lowered automatically for a distance in case of any obstruction in its one-button rising process.

### Remote Lowering of Power Window

Press and hold the unlock button on the remote control key for about 2s to lower all window glass in turn.

### Initialization Learning of Driver's Side Power Window\*

The driver's side window may lose the one-button rising and lowering functions in some cases, such as battery connection after disconnection. In case of such outage, the window initialization learning shall be conducted first. First, pull upward the driver's side switch till the window glass is closed completely, and continue to pull upward the switch for at least 5s and release it. Now the initialization learning is completed. If the one-button raising or lowering function is still unavailable after initialization learning, it is recommended to drive to the MG Authorised Service Center for check and repair.

### Power Window Lock Button

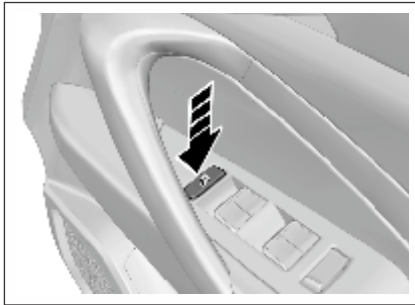

The power window lock button can lock the front passenger's side and rear power window switches. Press the button, and other power window switches are locked. The windows can only be operated with the driver's side window control panel.

Press the button once again, and the lock can be released.

#### Caution

**Children may operate the power window and may get stuck by the window when they operate it or may get out of the vehicle from the window, leading severe casualties. Please use the power window lock when there is a child in the vehicle.**

### Sunshade

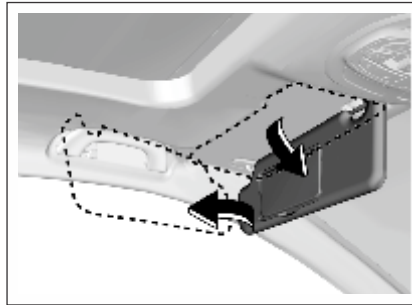

Your vehicle is configured with sunshade which can reduce dazzling effect on the driver and passengers.

The sunshade can move upward, downward and sideward.

Depending on the configuration, the sunshade may be equipped with a bill fold and vanity mirror.

### Auxiliary Handrail



Above the front passenger's side door and rear doors, an auxiliary handrail is installed. The handrail of some models is equipped with a clothes hook.

The auxiliary handrail is convenient for passengers to get in and out of the vehicle. The passengers can also grab the handrail to help maintain the sitting position when the vehicle speed is fast.

While using the auxiliary handrail, hold it downward. When it is released, it will return automatically.

**Sunroof\***

When the ignition switch is at ON position, the power sunroof can be operated.

**Caution**

**Always observe the following notes:**

- **Do not stretch out the body or any object out of the sunroof.**
- **Please ensure that there is no object in and out of the sunroof before the sunroof is opened or closed.**
- **Do not place a heavy object on or around the sunroof.**
- **Make sure that there is no rubbish on the outer side of the sunroof.**
- **When the vehicle is left unattended, the sunroof must be closed.**

**All occupants must buckle seat belts in all cases no matter whether the sunroof is opened or closed.**

**If the notes above are not observed, severe injuries or vehicle damage will be caused.**

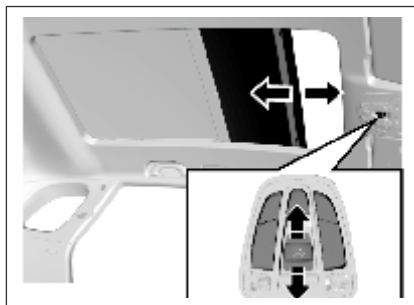
**Power Sunroof\*****Sunroof Sliding**

- To slide open the sunroof, push the rear end of the switch once quickly and release (operate within 0.3s). After the sunroof reaches the desired position, push the front end or rear end of the switch again, or push and hold the rear end, and release the switch after the sunroof reaches the desired position.
- To slide close the sunroof, push and hold the front end of the switch, and release the switch when the sunroof reaches the desired position but is not completely closed. To completely close the sunroof, push and hold the front end of the switch, and release the switch when the sunroof

stops moving, or push the front end of the switch once quickly and then release (operate within 0.3s).

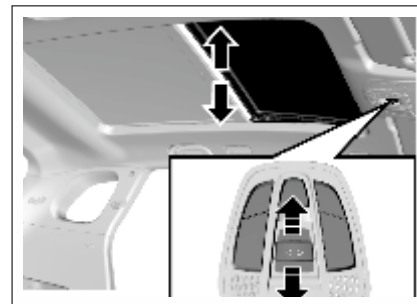
**Sunroof Tilting**

- To tilt open the sunroof, press the front end of the switch when the sunroof is completely closed, and release the switch when the sunroof reaches the desired position. To completely tilt the sunroof, press and hold the front end of the switch, and release the switch when the sunroof stops moving, or press the front end of the switch once quickly (operate within 0.3s).

## Sunvisor

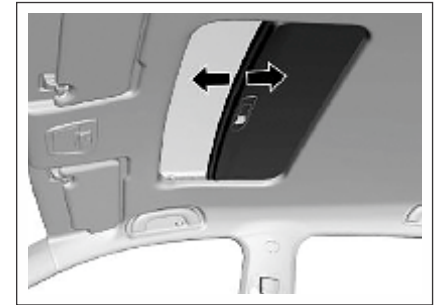

The sunroof visor can only be opened and closed manually.

### Panoramic Sunroof<sup>®</sup>

The panoramic sunroof is composed of two parts—the front part is tiltable and slidable and the rear part is fixed.

- To completely close the tilted sunroof, press and hold the rear end of the switch, and release the switch when the sunroof reaches the desired position but is not completely closed. To completely close the sunroof, release the switch when the sunroof stops moving, or press the rear end of the switch once quickly and then release (operate within 0.3s).

### One-button Opening or Closing of Sunroof

While operating the sunroof switch, you can press the front or rear end of the switch once quickly (operate within 0.3s), and the sunroof will be closed or opened automatically.

### Sunroof Anti-pinch Function

The sunroof will retract to prevent pinching persons when it contacts a certain rigid obstacle (such as the arm and head) in its one-button closing process.

### Sunroof Initialization Learning

The sunroof may lose its one-button opening or closing function in some cases, such as replacement of sunroof glass or motor. In case of such outage, the sunroof initialization learning shall be conducted first. When the

sunroof is completely closed, press and hold the front end of the switch; release the switch temporarily and then continue to press and hold the switch for at least 5s when the sunroof glass tilts completely; finally, release the switch. At this time, the sunroof glass will shake slightly, indicating that the initialization learning is completed. If the one-button opening or closing function is still unavailable after initialization learning, it is recommended to drive to the MG Authorised Service Center for check and repair.

### Sun Blind

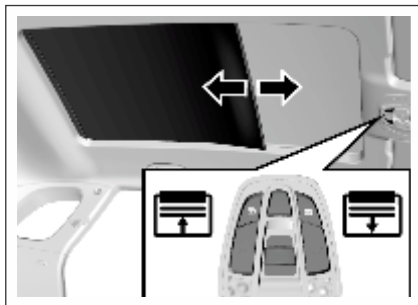

Press the open or close button of the sun blind to slide open or close the sun blind. When it reaches the desired position, release the button.

Short press the button, and the sun blind can be opened or closed automatically.

### Sunroof Tilting

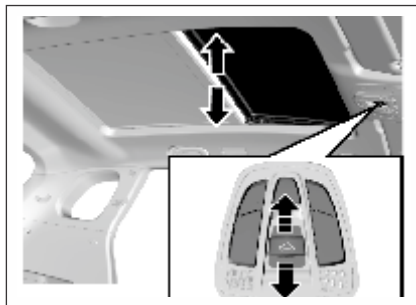

The front part of the sunroof can be tilted.

To tilt open the sunroof, push the sunroof switch backward when the sunroof is completely closed, and release the switch when the sunroof reaches the desired position. To completely tilt open the sunroof, push and hold the switch, and then release the switch when the sunroof stops moving.

You can also push the sunroof switch (short press) backward once quickly, and the sunroof will be tilted open automatically.

To close the tilted sunroof, push the sunroof switch forward, and release the switch when the sunroof reaches the desired position. To completely close the sunroof, release the

switch when the sunroof stops moving. You can also push the sunroof switch (short press) forward once quickly, and the sunroof will be closed automatically.

### Sunroof Sliding

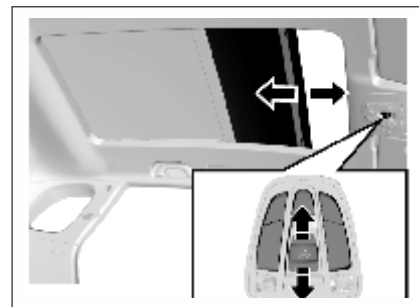

The sunroof can be slid open backward after it is completely tilted open.

To slide open the sunroof, push the sunroof switch backward, and release the switch when the sunroof reaches the desired position. You can also push the sunroof switch backward once quickly (short press), and the sunroof will be slid open automatically.



To slide close the sunroof, push the sunroof switch forward, and release the switch when the sunroof reaches the desired position. To completely close the sunroof, release the switch when the sunroof stops moving. You can also push the sunroof switch forward once quickly (short press), and the sunroof will be slid close automatically.

#### **One-button Opening or Closing**

Push the switch once quickly (short press) while operating the sunroof switch, and the sunroof can be closed or opened automatically.

In the process of opening, push the switch backward once quickly (short press) to tilt open the sunroof; push again to slide open the sunroof.

In the process of closing, push the switch forward once quickly (short press), and the sunroof will be completely closed automatically.

To stop in the process of automatic opening or closing, push the switch once.

#### **Anti-pinch Function**

The sunroof and the sun blind will retract to reduce pinching risks when they contact a

certain rigid obstacle (such as the arm and head) in their one-button closing or remote closing process.

#### **Remote Sunroof Opening**

Press the unlock button of the remote control for about 2s, the sun blind and sunroof will completely be opened automatically.

#### **Sunroof Initialization Learning**

The sunroof or the sun blind may lose its one-button opening or closing function in some cases, such as replacement of sunroof glass or motor. In such cases, the sunroof or sun blind initialization learning is necessary.

**Method:** Move the sunroof or sun blind to the completely close position; push the sunroof switch forward for about 10s or press the close button of the sun blind for about 10s; when the operation sound of the sunroof mechanism is heard, the sunroof or sun blind initialization learning is completed. If the one-button opening or closing function still cannot be recovered after initialization learning, please drive to the MG Authorised Service Center for check and repair.

#### **Shutdown Delay Function**

Within 30s upon vehicle shutdown, the sunroof and sun blind can be closed with buttons but cannot be opened.

#### **Linkage Function**

The linkage function of the sunroof and sun blind enables passengers in the vehicle to see the sunroof glass position when the sunroof is opened and to avoid forgetting to close the sunroof when the passengers leave the vehicle.

When the sunroof sun blind is completed closed, the sun blind will move the half-open position along with the sunroof if the sunroof switch is pushed backward and held. If the button is released in the long pressing process, the glass will stop moving immediately, and the sun blind will move to the half-open position and then stop.

When the sunroof glass is completely opened, if the sun blind close button is long pressed, the glass will be closed along with the sun blind. If the button is released in long pressing process, the glass will stop moving, and the sun blind will stop moving (not reaching the half-open position) or return to the half-open position (exceeding the half-open position)



## Seats and Protective Devices

<b>Headrest .....</b>	<b>34</b>	<b>7 Seat Variant.....</b>	<b>39</b>
• Position.....	34	• Seat Backrest Adjustment and Folding	39
• Height Adjustment.....	34	• Seat Overturn .....	39
<b>Front Seat.....</b>	<b>34</b>	• Seat Backrest Folding.....	40
• Seat Position and Backrest		• Seat Layout Diagram.....	40
Normal Condition .....	34	<b>Seat Belt .....</b>	<b>40</b>
<b>Seat Position Adjustment .....</b>	<b>35</b>	• Wearing.....	41
• Manual Adjustment Type*.....	35	• Height Adjustment*.....	42
• Electric Adjustment Type*.....	35	• Unbuckle .....	42
<b>Seat Backrest Adjustment.....</b>	<b>36</b>	• Middle Row / Rear Row Seat Belt.....	42
• Manual Adjustment Type*.....	36	• Seat Belt Use During Pregnancy.....	43
• Electric Adjustment Type*.....	36	<b>Child Seat .....</b>	<b>44</b>
• Ventilation Seat Control Button.....	36	• Child Restraint System Type.....	44
<b>Driver's Seat Height Adjustment.....</b>	<b>37</b>	• ISOFIX .....	45
• Manual Adjustment Type*.....	37	<b>Table of Vehicle Handbook Information</b>	
• Electric Adjustment Type*.....	37	<b>on Child Restraint Systems.....</b>	<b>47</b>
<b>Seat Backrest Adjustment</b>		<b>Air Bag System .....</b>	<b>48</b>
<b>and Folding .....</b>	<b>37</b>	• Air Bag Indicator .....	48
<b>Rear Seat .....</b>	<b>38</b>	<b>Air Bag Position .....</b>	<b>49</b>
• Rear Seat (5-Seat Model) .....	38	• Frontal Air Bag .....	49
• Armrest.....	38	• Side Air Bag* .....	49
• Middle Row Seat .....	38	• Side Curtain Air Bag .....	49

## Headrest

### Position

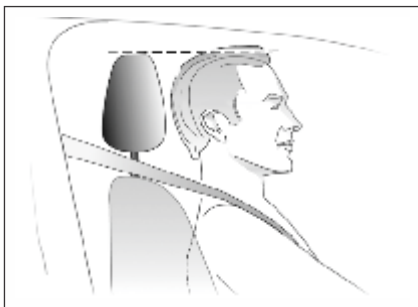

The middle position of the headrest should be on the same horizontal line as the occupant's eyes. For tall persons, if the above point cannot be met, the headrest shall be adjusted to the highest position; for short persons, the headrest shall be adjusted to the lowest position.

### Warning

**Before driving, make sure that the headrest is adjusted properly.**

**Removal or improper adjustment of the headrest will cause severe injuries to the head and neck in collision accidents.**

### Height Adjustment

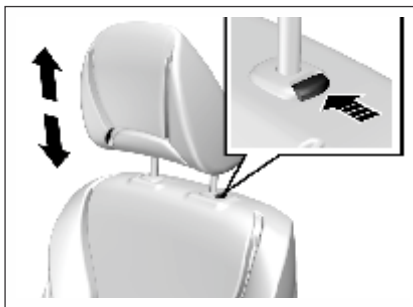

To adjust the headrest upward, pull the headrest upward to a proper position and fix it. To remove the headrest, press and hold the release switch.

To adjust the headrest downward, press and hold the release switch and push the headrest downward to a proper position; then, release the release switch for fixation.

Pay attention not to press the headrest forcibly to avoid injuring the finger pressing the release switch.

## Front Seat

### Seat Position and Backrest Normal Condition



- When you sit on the seat, make your hips as close to the backrest as possible. Adjust the distance between the seat and the pedal to make your leg slightly bend when you press the pedal. The passenger's seat shall slide as backward as possible.
- When you sit on the seat, make your shoulders lean on the backrest as backward as possible. Set the backrest inclination angle to make your arm conveniently to reach the steering wheel while slightly bending the arm. Keep the shoulders leaning against the backrest while turning the steering wheel. The backrest shall not incline excessively backward.

- The seat height shall be so set that the occupant can see all directions and the positions of all display instruments. The head must be at least one hand away from the roof lining

The thighs are right on the seat without constriction.

### Warning

**Correctly adjust the seat before driving the vehicle.**

**Never adjust the seat when the vehicle is running because the seat may not move as controlled.**

## Seat Position Adjustment

### Manual Adjustment Type\*



Pull upward the adjustment lever on the front lower part of the seat to adjust the seat forward or backward, and release the lever after the seat is adjusted to a proper position.

Try to slide the seat forward and backward to ensure that the seat is locked at a proper position.

### Electric Adjustment Type\*

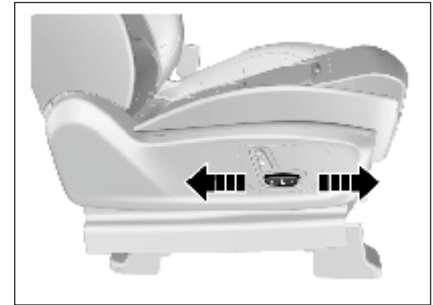

As shown in the figure, the electric adjustment switch is on the outer side of the seat. Push the switch forward or backward, and the seat will move forward or backward accordingly. Release the switch when it reaches a proper position.

### Note

**If the seat does not move when the switch is pushed, the seat may be already at the front or rear limit position, or the vehicle battery is out of power. Please check for confirmation. Never turn the switch forcibly to avoid damaging it.**

## Seat Backrest Adjustment

### Manual Adjustment Type\*



Pull up the handle near the seat cushion; adjust the backrest inclination angle to a proper position; then, release the handle. Please do not lean on the seat backrest while adjusting.

After adjusting the seat backrest, try to shake the backrest to ensure that the backrest is locked.

#### Note

If the backrest does not move when the switch is turned, the backrest may be already at its limit position, or the vehicle battery is out of power. Please check for confirmation. Never turn the switch forcibly to avoid damaging it.

### Electric Adjustment Type\*



As shown in the figure, turn the adjustment switch forward and backward, and the backrest will be folded forward or unfolded backward. Release the switch when it is adjusted to a proper position.

#### Warning

**The backrest plays an important protection role when the vehicle is running. Unlocked backrest may cause severe personal injuries in case of sudden braking or a collision.**

**Any time after adjusting the seat backrest, shake the backrest to check whether it is locked even though no passenger occupies the seat.**

### Ventilation Seat Control Button

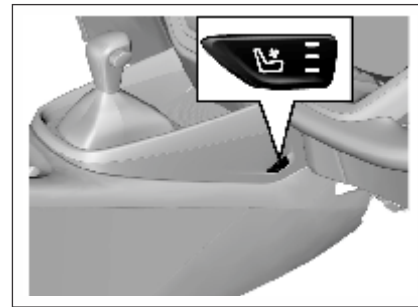

Some variants of vehicles have the ventilation function for the front seats. As shown in the image, the control button for ventilation is located in the side of console. Press the button to active the ventilation function, meanwhile 3 LED lights are on and with the maximum fan speed; press the button again, it remains 2 LED lights on and with medium fan speed; press the button again, only 1 LED light on and with minimum fan speed; press button again, the ventilation function will be turned off. Customer could adjust the fan speed to get the appropriate ventilation performance and keep a comfortable driving experience.

## Driver's Seat Height Adjustment

### Manual Adjustment Type\*



Turn the handle on the outer side of the seat upward and downward until the seat is adjusted to the desired height. While adjusting the seat height, the seat must be loaded. Therefore, please sit on the seat before adjustment; otherwise the adjustment device may be damaged.

### Electric Adjustment Type\*



As shown in the figure, rotate the height adjustment switch on the outer side of the seat cushion, and then release the switch after the seat is adjusted to proper height.

The electrically-adjustable front passenger's seat cannot be adjusted upward or downward.

## Seat Backrest Adjustment and Folding



The seat backrest inclination angle is adjustable within a certain range.

First hold the backrest with hands because the backrest will be folded quickly and may cause impact or injuries after the backrest release belt is pulled up. Then, pull the backrest release drawstring on the seat side backward, and release the drawstring after a proper angle is obtained.

To fold the seat backrest, pull up the drawstring and fold the backrest forward. Overturning the seat cushion first and then folding the backrest can fold flat the backrest to the greatest extent.

To recover, pull up the drawstring and unfold the backrest to a proper angle. Finally, try to shake the backrest to check whether it is fixed.

#### Note

**Hold the backrest first and do not make the head or other body parts within the backrest folding range before pulling the backrest drawstring and folding the backrest. Otherwise, the backrest will be folded quickly and may cause impact or injuries.**

### Rear Seat

#### Rear Seat (5 Seat Model)

Rear seat cannot be adjusted forward or backward.

#### Armrest



As shown in the figure, the second row seat is configured with an armrest. Deploy the armrest for use. There is a cup holder on the armrest. After use, please put back the armrest.

Seat Position and Backrest Angle for Measurement of Seat Cushion Thickness. For measurement of the seat cushion thickness, the seat can be in any position.

The seat backrest shall incline backward for a certain angle from the vertical position. The angle is 23°, 25° and 20° respectively for the 1st and 2nd row.

### Middle Row Seat

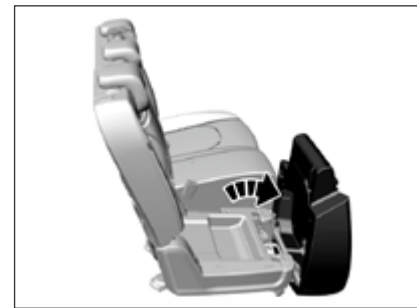

As shown in the figure, after the cushion is unlocked, pull out the cushion forward and lift up the rear part of the cushion to overturn it. The two cushions can all be overturned.

To recover, install the cushion back in opposite order, and press down the cushion with force. Try to shake the seat cushion to make sure that it is locked.



## 7 Seat Variant

### Seat Backrest Adjustment and Folding



The seat backrest inclination angle is adjustable within a certain range.

First hold the backrest with hands because the backrest will be folded quickly and may cause impact or injuries after the backrest release belt is pulled up. Then, pull the backrest release lever on the seat side backward, and release the lever after a proper angle is obtained.

To fold the seat backrest, pull up the lever and fold the backrest forward. Overturning the seat cushion first and then folding the backrest can fold flat the backrest to the greatest extent.

To recover, pull up the lever and unfold the backrest to a proper angle. Finally, try to shake the backrest to check whether it is fixed.

#### Note

**Hold the backrest first and do not make the head or other body parts within the backrest folding range before pulling the backrest drawstring and folding the backrest. Otherwise, the backrest will be folded quickly and may cause impact or injuries.**

### Seat Overturn

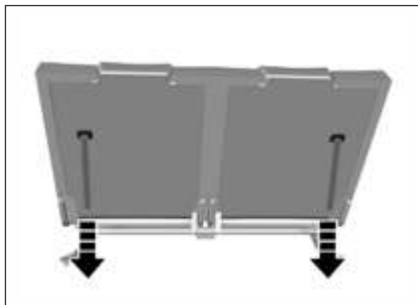

For the 7 seater variant, when you need to sit at the rear seat you can overturn the left side of middle row seat. As shown in the figure, you can pull the lever until the seat lock is detached. To recover, pull up the lever and push back the seat until it safely locked in position.

**Seat Backrest Folding**

As shown in the figure, pull the strap on the back of the seat and fold the backrest forward. To recover, pull the drawstring and unfold the backrest until it is locked in position.

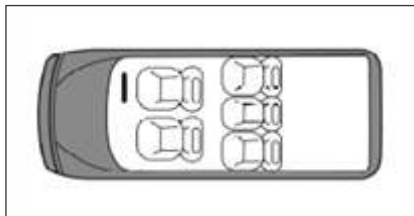
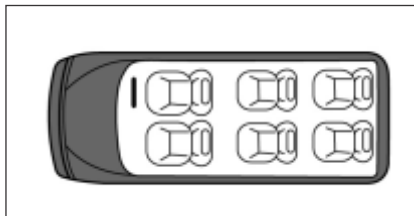
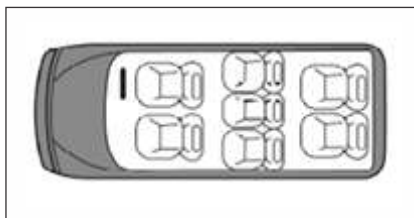
**Seat Layout Diagram****5 Seater layout diagram****6 Seater layout diagram****7 Seater layout diagram****Seat Belt**

The seat belt is designed only for one passenger each time. It is not applicable to a passenger under 12 years old or under 150 cm high. Check all parts of the seat belt system for damage and abnormal function regularly. Please replace the damaged parts and components. It is strongly recommended to have the seat belt or deployed seat belt tensioner at the MG Authorised Service Center replaced after an accident.

**Seat Belt Force Limiter\***

It is configured on the seat belts for the driver's seat and the left seat of second row. For some models, the front passenger's seat belt is also configured with a force limiter.

The force limiter can reduce the stress applied on the body through the seat belt damping release in case of a collision accident.

#### **Seat Belt Pretensioner\***

Depending on different models, it is configured on the seat belt for the driver's seat, front passenger's seat of the left seat of the second row. In case of a severe head-on or rear-end collision, the front part of the seat belt will be tensioned.

The deployed seat belt pretensioner must be replaced by the MG Authorised Service Center. The seat belt pretensioner can only be deployed once.

#### **Note**

**Make sure that the seat belt is not damaged or clamped by a sharp object. Prevent dust from getting in the seat belt recoiler.**

#### **Warning**

**Improper operation (for example removal or installation of seat belt or seat belt anchor buckle) will trigger the seat belt tensioner, leading to injury risks.**

#### **Warning**

**Buckle the seat belt each time before driving the vehicle. In case of an accident, a passenger who does not buckle the seat belt may be at risk.**

#### **Note**

**It is not allowed to add any accessory or other object that may interfere with the operation of the seat belt. Do not change any seat belt component.**

#### **Warning**

**The seat belt shall not be buckled against a hard or fragile object in your pocket. Otherwise, the hard object will hurt you and the fragile object may be damaged in case of emergencies.**

#### **Note**

**Pay attention to prevent foreign matters from getting in the seat belt buckle (such as sunflower seed shell and button); otherwise the seat belt buckle will fail.**

### **Wearing**



1. Pull out the seat belt from the recoiler, and fasten it across the body without twisting.

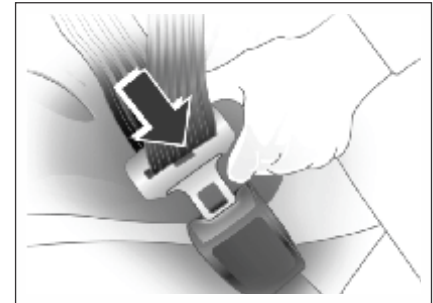

2. Put the latch plate in the buckle for fixing. Pull the shoulder belt forcibly to adjust the tightness degree of hip belt.

Loose or heavy clothing will hamper close wearing the seat belt. Do not place any object (such as hand bag and mobile phone) between the seat belt and your body.

#### Height Adjuster\*

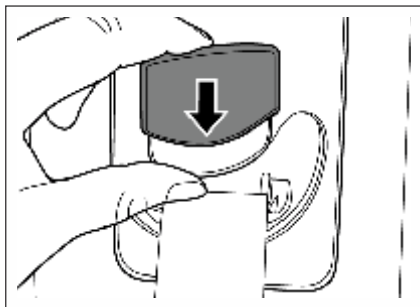

Depending on different models, the front row seat belt of some models can be adjusted in height. Press the height adjuster of the seat belt upper fixing point and move it upward or downward. Release the adjuster after adjustment.

#### Unbuckle

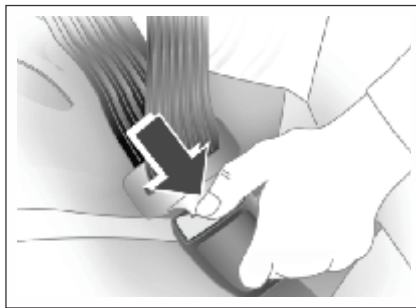

To unbuckle the seat belt, please press the red button on the buckle.

#### Middle Row / Rear Row Seat Belt Left and Right Seat Belt

For buckling and unbuckling of the left and right seat belts of the rear row, please refer to that of the front seat belt.

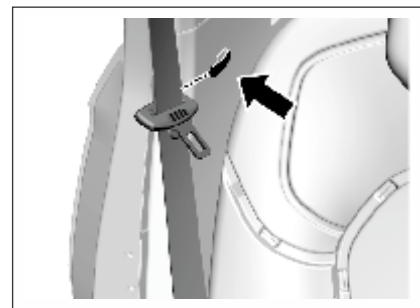

As shown in the figure, there is a clip on the trim panel near the second row seat backrest. Please hang the seat belt to the clip for fixing each time after use.

#### Middle Seat Belt of Rear Row

Wearing:

1. Pull out the seat belt from the backrest first and sit well.

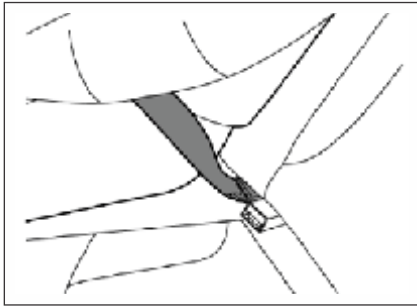
**Seat Belt Use during Pregnancy**

2. Plug the latch plate at the seat belt end into the small buckle on the left side of the seat.

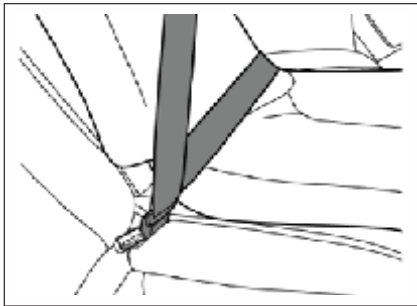

3. Plug the other latch plate (movable) into the buckle on the right side of the seat.

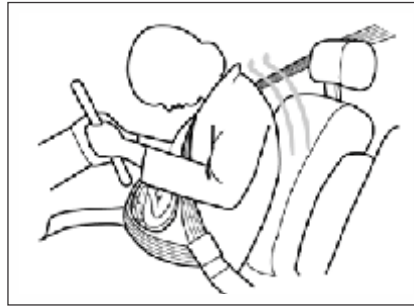

The seat belt provides protection for everybody, including a pregnant woman. Like all passengers, if pregnant women do not wear the seat belt, severe personal injuries are more likely to be caused to them. The pregnant woman shall wear the hip/shoulder seat belt during the whole pregnancy, and the hip belt shall be fastened as low as possible. The best way to protect a fetus is to provide safety protection to its mother. If the seat belt is fastened correctly, the fetus is not vulnerable to injury in case of a collision. For a pregnant woman or any person, correct wearing is the key to exert the best protection effect of the seat belt.

**Warning**

The hip belt shall be placed as low as possible to go across the pelvis, so as avoid force on the belly.

## Child Seat

The vehicle is not equipped with a child seat. If you want to add one, a child seat that is applicable to ISOFIX “general” type can be selected. The child seat can only be placed on the second row seat. The front seat is not equipped with the anchor system bracket. The statistical data of accidents show that placing the child seat on the second row seat can largely improve the child safety.

### Caution

**For a little child, a child seat shall always be used. Never hold a child with arms while riding in the vehicle. Never allow a child to stand or kneel on a seat or in the luggage compartment when the vehicle is running.**

### Caution

**An unfixed child seat may be thrown out of the vehicle in case of a collision or emergency stop. The child seat must be correctly and securely fixed even it is not used.**

### Caution

**If the child seat is put in a closed compartment in hot weather, the child seat temperature will be very high. Make sure that the child seat temperature is not very high before putting a child in the seat. If the child is too small and the seat belt cannot provide the best protection for it, please make sure that a proper child seat is used to provide safety protection.**

## Child Restraint System Type



According to AIS072/ECE R44, the child restraint system can be classified as the following 5 groups:

**Group 0:** for child with body weight less than 10 kg.

**Group 0+:** for child with body weight less than 13 kg.

**Group I:** for child with body weight more than 9 kg and less than 13 kg.

**Group II:** for child with body weight more than 15 kg and less than 25 kg.

**Group III:** for child with body weight more than 22 kg and less than 36 kg.



Please select a suitable child seat according to the child body weight and body figure.

For infants under one year old, their bones are very fragile, and a rearward-facing child seat shall be used.



## ISOFIX

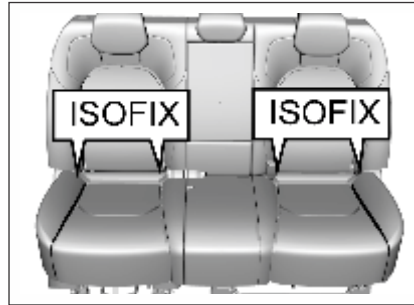

To fix the child seat:

1. The ISOFIX lower fixing point is on the joint between the second row set backrest and the seat cushion back. Its position can be identified through the label on the lower edge of the backrest. The left and right seats are equipped with a set of ISOFIX respectively.
2. Clear up the objects on the seat. Note to remove the seat belt and seat belt buckle to avoid affecting accurate fixing of the child seat.
3. Put the child seat on the second row seat.

## Caution

The size and configuration range of the child seat is very wide. Not all child seats are applicable to your vehicle due to the effects of the vehicle trim as well as the seat shape and size. You have responsibility to ensure that the child seat installed matches with your vehicle and that the child seat can be connected correctly to the vehicle with the child seat anchor system. If the child seat does not match with your vehicle size and the child body figure or the connection to your vehicle is incorrect, severe personal injuries will be caused to the child and other passengers in the vehicle in case of a collision.

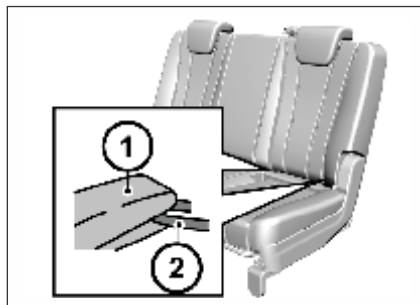

4. Connect the fixing caliper on the child seat to the on-vehicle fixing device. Operate according to the child seat instructions.



5. Connect the upper strap of the child seat to the corresponding fixing point of the

vehicle. Refer to the child seat instructions to get to know when and how to strain the upper strap. As shown in the figure, the ISOFIX upper fixing point is on the roof above the rear seat. Open the outer cover from the upper edge.

6. Push and pull the child seat in all directions to make sure it is safely secured.
7. Make sure that the child seat temperature is not very high before putting a child in the seat.

In case of a serious collision accident, the ISOFIX may be damaged. It may be necessary to repair and replace some parts. Please check the ISOFIX after a collision.



**Table of Vehicle Handbook Information on Child Restraint Systems installation suitability for various seating positions**

Mass Group	Seating position (or other site)				
	Front Passenger	Front Passenger	Rear Centre	Intermediate Outboard	Intermediate Centre
Group 0 up to 10 kg	X	U	NA	NA	NA
Group 0+ up to 13 kg	X	U	NA	NA	NA
Group I 9 to 18 kg	UF	U	NA	NA	NA
Group II 15 to 25 kg	UF	U	NA	NA	NA
Group III 22 to 36 kg	UF	U	NA	NA	NA

Key of letters and their description:

U = Suitable for "universal" category restraints approved for use in this mass group

UF = Suitable for forward-facing "universal" category restraints approved for use in this mass group

L = Suitable for particular child restraints given on attached list. These restraints may be of the "specific vehicle", "restricted" or "semi universal" categories.

B = Built-in restraint approved for this mass group.

X = Seat position not suitable for children in this mass group.

#### Note

- 1) As indicated above only Rear RH seat is recommended for CRS using Adult Safety Belt. (In case ISOFIX is not used)
- 2) We only recommend using Universal Category ISOFIX seats for Children in recommended positions. (In case of ISOFIX CRS with latch & Top Tether, both left and right position may be used)

## Air Bag System

Depending on the vehicle configuration, the system includes the following air bags:

- Driver frontal air bag
- Front passenger frontal air bag. (If equipped)
- Front side air bag. (If equipped)
- Side curtain air bag (if equipped)

For all air bags, the letter “AIRBAG” is marked on the trim panel or the label near to its deployment opening. For frontal air bags, the letter “AIRBAG” for the driver is located in the middle of the steering wheel, and that for the front passenger is located on the instrument panel. For lateral-impact air bags, the letter “AIRBAG” is located on the backrest side, near to the door. The letter “AIRBAG” for side curtain air bags is located on the roof lining trim panel.

The air bag can supplement protection on the basis of correcting wearing the seat belt. Although nowadays the air bags are designed to reduce the injury risks caused by the impact force when the air bag is inflated, all air bags must be inflated rapidly to exert its effect.

The important notes about the air bag system are as follows:

### Warning

**Even if an air bag is equipped, you may also be injured seriously or lose your life in a collision accident if you do not use the seat belt. The air bag is designed to be used along with the seat belt but not to replace the seat belt.**

### Warning

**If an occupant sits next to or get too close to the air bag, he/she may be injured seriously or lose life due to inflating of the air bag. Therefore, never sit too close to the air bag.**

### Warning

**It is forbidden to let a child, infant, pregnant woman and the sick and weak sit on the front seat equipped with air bag. Never install a backward-facing child seat on the front seat for the child may be injured seriously or lose life when the air bag is inflated. The seat belt and air bag can protect adults and adolescents but not children and infants. Children and infants need special child protection devices (such as child seat) to get corresponding protection.**

## Air Bag Indicator



On the instrument panel, there is an air bag indicator which displays the air bag shape symbol. The system will check whether the air bag circuit system has a fault and give corresponding prompt through the indicator. Refer to the Chapter “Instruments and Controls” for detailed information.

## Air Bag Position

### Frontal Air Bag

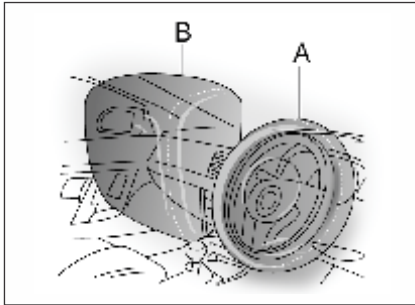

As shown in the Figure A above, the driver frontal air bag is located in the middle of the steering wheel.

As shown in the Figure B above, the front passenger frontal air bag is located in the passenger's side instrument panel.

### Side Air Bag\*

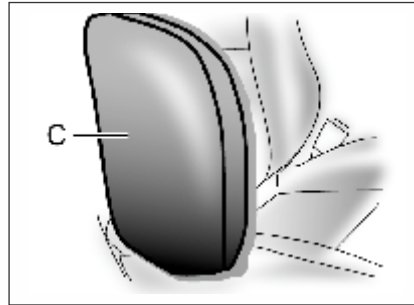

As shown in the Figure C, the front seat side air bag is installed on the backrest side near to the door.

### Side Curtain Air Bag

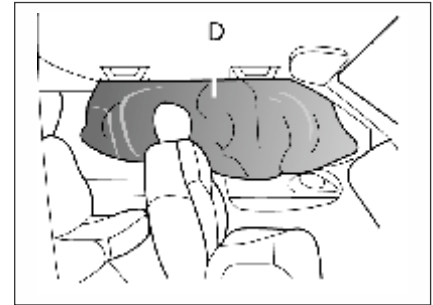

As shown in the Figure D, the side curtain air bag is installed at the side wall and roof joint, on the roof lining or the trim panel.

### Warning

**If there is any other object between the occupant and the air bag, the air bag may not be able to be inflated normally or the air bag may cause the object to squeeze the occupant's body when it is inflated, leading to severe injuries or even death. Please never use a seat accessory (such as seat jacket) that may hinder the inflating of the lateral-impact air bag.**

### **When Shall the Air Bag Be Inflated?**

The frontal air bag is designed to be inflated in moderate to severe head-on collision or almost head-on collision to reduce severe injury risks of the driver's and the front passenger's head and chest.

Whether the frontal air bag is inflated do not mainly depends on the vehicle running speed. It depends on the impacted object, impact direction and vehicle deceleration within unit time during collision.

The frontal air bag may be inflated in different collision speed. The air bag inflation depends on the impact direction (straight or in certain angle) at the moment of collision and whether the impacted object is fixed or movable, deformable or not and narrow or wide. Due to different design of each vehicle, the collision inflation conditions of the frontal air bag may vary. The frontal air bag will not be inflated in case of vehicle overturn, rear-end collisions and most lateral-impact collisions. The frontal air bag may not be inflated in slight head-on or nearly head-on collisions, lateral or diagonal collisions, collisions to cylindrical objects (such as telegraph pole and tree trunk), rear-end collisions under large vehicle (trucks, etc.) breast board and lateral glancing collisions. As

per the design, the seat lateral-impact air bag and the side curtain air bag will be inflated according to the impact position in case of the moderate to severe lateral collisions.

The seat lateral-impact air bag and the side curtain air bag will not be inflated in case of head-on collisions, nearly head-on collisions, vehicle overturn or rear-end collisions. The seat lateral-impact air bag and the side curtain air bag may not be inflated in slight side collisions and lateral-frontal or diagonal collisions.

As per the design, the seat lateral-impact air bag and the side curtain air bag will be inflated on the side to which the vehicle is collided. The air bag will not be triggered in all collision accidents. For a particular accident, it shall not simply judge whether the air bag should be inflated according to the causalities, vehicle damage or repair and maintenance expenses. Your vehicle is equipped with a collision sensing and diagnosis module. If a collision accident reaches certain strength, the module may record relevant collision information after the collision. If you have any doubt on the working situation of your air bag in a collision accident, please contact the MG Authorised Service Center timely to provide professional analysis and diagnosis for you.

### **How is the Air Bag Inflated?**

In the inflation process, the sensing system will send an electronic signal to trigger the gas generator; the generator will release gas to inflate the air bag and to make the air bag pops up from the cover plate. The gas generator, air bag and relevant members are all components of the air bag module.

### **How Does the Air Bag Provide Protection?**

The air bag supplements protection provided by the seat belt by distributing the impact force more evenly to the occupant's body. However, some occupants' bodies do not move toward the air bags in collisions where an external object intrudes into the vehicle. The air bag cannot provide corresponding protection. The air bag shall only be deemed as a supplementary device of the seat belt.

### **What Will You See After the Air Bag is Inflated?**

After the air bag is inflated, it will be deflated quickly. Somebody may not note that the air bag is ever inflated because the bleeding speed is very fast. For deflated air bag, some smoke and dust may come out from its air event.

**Warning**

**When the air bag is inflated, there may be dust spread in the air. All persons in the vehicle shall get off the vehicle as soon as possible. If you have a breathing problem and cannot get off the vehicle, open windows or doors to get fresh air. If you have a breathing problem after the air bag is inflated, please see a doctor as soon as possible.**

If the vehicle power supply system can still function normally after a collision, the vehicle has the functions of unlocking doors automatically, turning on the hazard warning lamp and cutting off the fuel system after the air bag is inflated. The driver can use corresponding function switch to lock doors, turn off indoors lamps and turn off the hazard warning lamp.

The deployment of the front passenger air bag may also cause damage to the windshield.

- The air bag can only be inflated once as per its design. After the air bag is inflated, some parts of the air bag system need to be replaced. If you do not have these parts replaced, the air bag system will be unable to provide protection in next collision

accident. The air bag system parts that shall be replaced include the air bag module, air bag control module, seat belt pretensioner and other parts.

- Work related to the air bag system can only be done by technicians with corresponding qualification. Improper repair and maintenance may cause that the air bag system cannot function normally. Please drive to the MG Authorised Service Center for repair and maintenance.

**Air Bag System Repair, Maintenance and Replacement**

The air bag system must be maintained by qualified and professional technicians. Improper maintenance will cause that the air bag system cannot function normally. Please drive to the MG Authorised Service Center for repair and maintenance of the air bag system.

**Warning**

**If the air bag cover is damaged, opened or broken, the air bag may not function normally. It shall be repaired as soon as possible.**

**Warning**

**Never stick or cover any object on the air bag cover surface or refit the air bag cover; never try to repair, adjust or remove or install any air bag system component; never try to refit the front bumper of the vehicle body by yourself.**

**The Frontal Air Bag May Not Be Inflated in the Following Collisions**

The frontal air bag will usually not be inflated in case of side collisions, rear-end collisions, turnover or low-speed head-on collisions. No matter what kind of collision, only when the vehicle generates sufficient forward deceleration, will the frontal air bag be inflated.

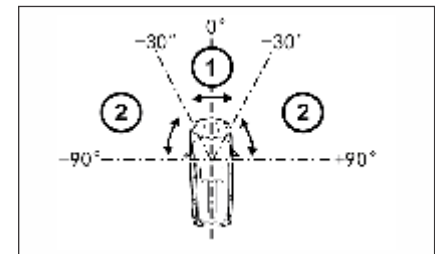

- Head-on collision angle over 30° from vehicle longitudinal direction

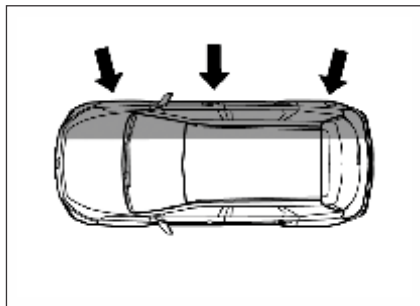

- Side collision

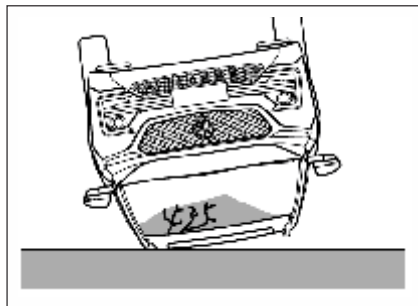

- Overturn, falling from high place, rolling

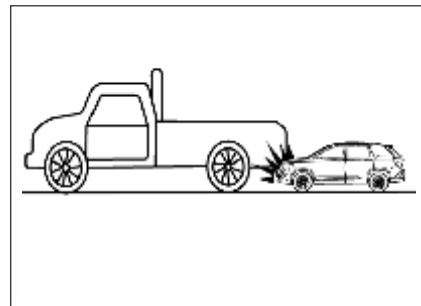

- Hit into front vehicle bottom, especially truck bottom

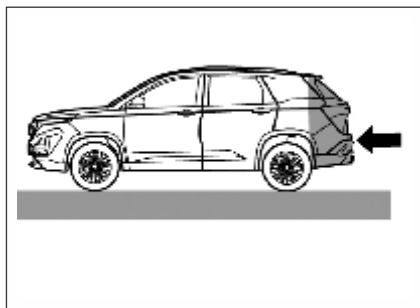

- Rear-end collision

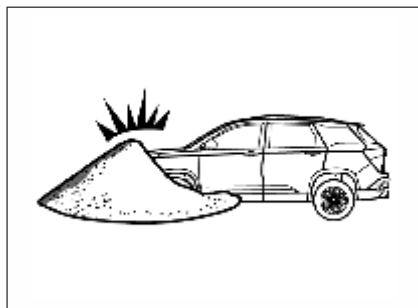

- Hit deformable objects, such as sandpile, guard bar, column and tree

**Side Air Bag / Side Curtain Air Bag (If Equipped) May not Be Inflated in the Following Collisions**

In case of side collisions with certain angle or collisions to vehicle body side (not passenger compartment), the side air bag/side curtain air bag system may not be activated.

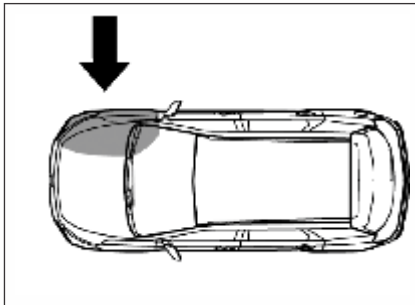

- Vehicle body side (not passenger compartment) collision

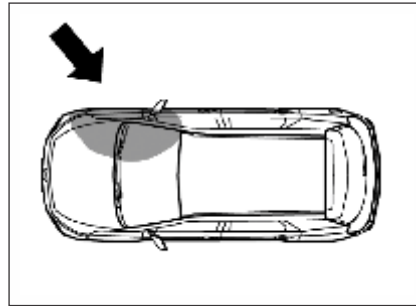

- Off-vertical side collision

The side air bag/side curtain air bag will usually not be inflated in case of head-on collision, rear-end collisions, overturn or low-speed side collisions.

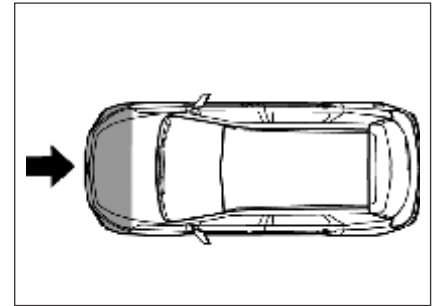

- Fall into or drive into a deep pit
- Head-on collision

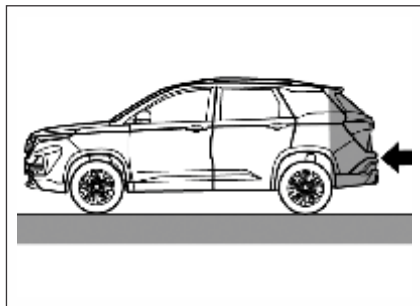

- Rear-end collision

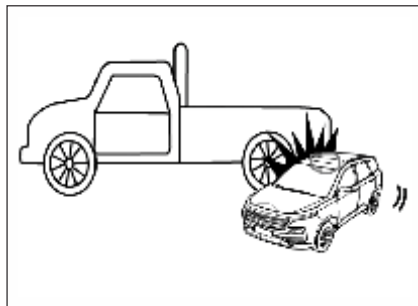

- Side collision to truck during drifting

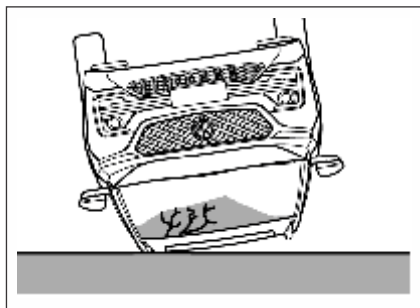

- Overturn, falling from high place, rolling

### Important Note



Do not use a backward-facing child restraint system on a seat (front seat) protected by a frontal air bag (in activated state). Otherwise, severe injuries or even death may be caused to the child when the air bag is deployed.



## Storage

<b>Storage Box</b> .....	<b>56</b>
• Instrument Panel Right Storage Box .....	56
• Instrument Panel Central Storage Box .....	56
• Armrest Storage Box .....	56
• Glasses Box* .....	56
• Console Storage Box* .....	57
• Glove Box .....	57
• Seat Pocket .....	57
• Cup Holder .....	57
• Door Storage Groove and Armrest .....	58
• Rear Side Wall Storage Groove and Armrest .....	58
• Backrest Hook .....	58
• Luggage Compartment Cargo Cover* .....	59
<b>Roof Rail</b> .....	<b>60</b>
• Load Information .....	60

## Storage Box

### Instrument Panel Right Storage Box



### Instrument Panel Central Storage Box



The storage box is under the air-conditioning control panel.

### Armrest Storage Box

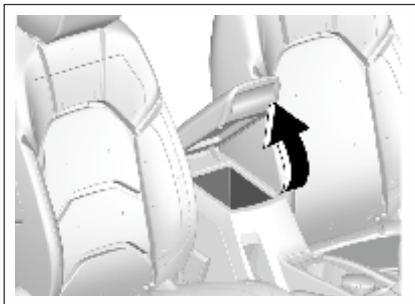

It is located between the front seats. Pull up the storage box cover to open it.

Close the storage box cover after using the box.

### Glasses Box\*

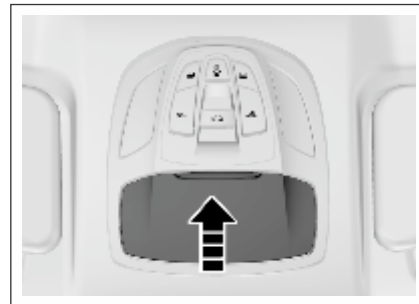

If equipped, the glasses box is located on the roof.

As shown in the figure, press the outer cover, and the glasses box will pop up automatically. Close the glasses box after use.

### Console Storage Box\*

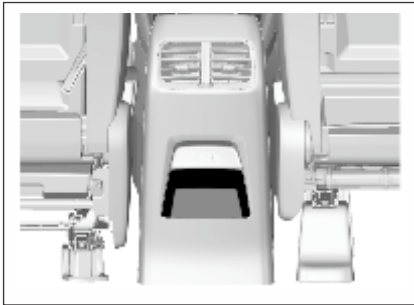

It is behind the armrest box.

### Glove Box

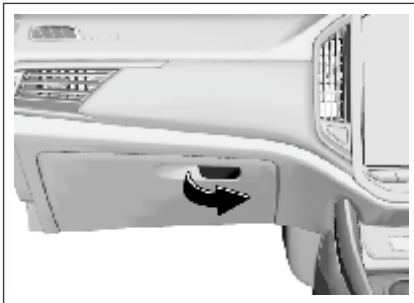

Pull the handle outward to open it. To close, push and fasten the glove box door inward.

### Warning

Keep the glove box door closed when the vehicle is running to reduce the injury risks in case of accidents or emergency braking.

### Seat Pocket



The seat pocket is located behind the front seat backrest.

### Cup Holder

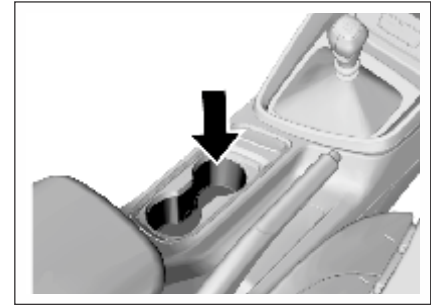

The cup holder is located on the console between the front seats. There are 2 cup holders on the rear row seat middle armrest.

### Warning

When the vehicle is running, it is forbidden to place a container that contains fluid but is not covered in the cup holder. If the fluid spills out, scald may be caused, or you may lose control on the vehicle due to distraction, leading to an accident.

### Door Storage Groove and Armrest



The door storage groove and armrest are located on inner side of the door panel.

### Rear Side Wall Storage Groove and Armrest

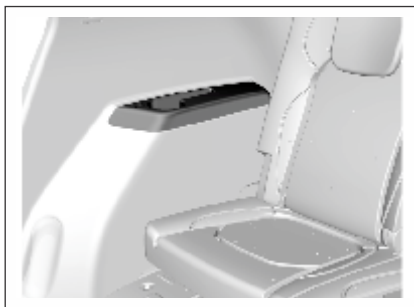

They are located on the left and right rear side walls.

### Backrest Hook

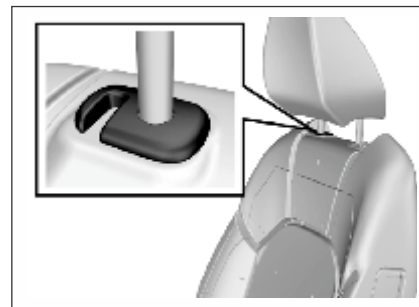

On the junction of each seat backrest and headrest, there is a hook. You can hang a shopping bag or other suitable object on the hook according to the demand.

### Luggage Compartment Cargo Cover\*

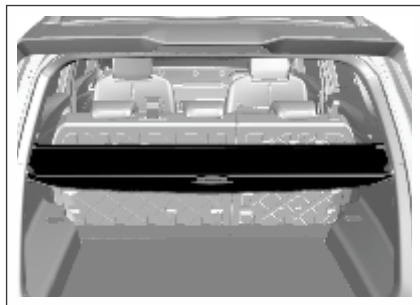

The cover is used to shield the objects in the luggage compartment.

### Packing Up Luggage Cover

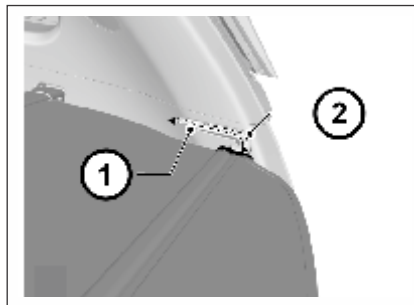

As shown in the figure, release the luggage cover plates from the guide slots on both sides of the luggage compartment, and the cover will retract automatically. To deploy the luggage cover, pull the luggage cover from the recoiler, and clamp the two ends of cover plate into the guide slots on both sides of the luggage compartment.

### Luggage Cover Removal

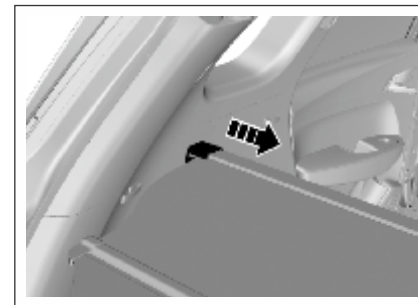

As shown in the figure, press the caps on both ends of the luggage cover recoiler toward the middle to remove the luggage cover from the vehicle.

To install the cover, press the caps on both ends toward to the middle, and align the caps to the slots and then release the caps to fix the recoiler in the slots.

**Warning**

**Do not place any object on the luggage compartment cargo cover. On one hand, the luggage cover cannot bear loads; on the other hand, the object may hurt occupants under emergencies.**

**Warning**

**Please place and fix the removed luggage cover properly; otherwise, the removed luggage cover may hurt occupants under emergencies.**

**Roof Rail**

The roof rail is an external trim item. To avoid damaging the vehicle, please do not use the rack to load heavy objects.

**Load Information**

- The heavy objects inside the luggage compartment shall be placed close to the backrest. Make sure that the backrest is fastened. If objects need to be piled in layers, heavy ones shall be placed in the bottom.
- Objects scattered in the luggage compartment shall be fixed to prevent them from sliding.
- The loaded object shall not be higher than the upper edge of the backrest.
- Any object shall not be placed on the luggage cover or the instrument panel. It is forbidden to cover the air bag or other parts on the instrument panel.
- The objects loaded shall neither hinder the operation of pedals, parking brake and shift lever nor limit the free movement of the driver. Do not put any object not fixed in the vehicle.
- Do not drive the vehicle when the liftgate open.

**Warning**

**It is forbidden to place a cigarette lighter, propane gas cylinder, perfume or other combustible / explosive materials in the vehicle. These articles may be on fire or explode when the vehicle is under high temperature for a long time.**

## Instruments and Controls

<b>Instrument Panel .....</b>	<b>62</b>		
<b>Controls .....</b>	<b>63</b>		
• Horn.....	63		
• Steering Wheel Adjustment* .....	64		
• Front Windshield Wiper and Washer* ..	64		
• Rear Windshield Wiper and Washer* ....	65		
• Exterior Entertainment Power Outlet* .....	65		
• Rear Accessory USB Power Outlet* .....	66		
• Driving Recorder USB Power Outlet .....	66		
• Rear Power USB Port.....	66		
<b>Warning Lamps,</b>			
<b>Gauges and Indicators .....</b>	<b>67</b>		
• Speedometer .....	67		
• Tachometer .....	67		
• Fuel Gauge .....	67		
• General Odometer .....	68		
• Small Odometer .....	68		
• Engine Coolant Temperature Gauge.....	68		
• Type-I Trip Computer Display Screen .....	69		
• Adjustment Lever.....	69		
• Wireless Charge Area .....	69		
<b>Type-II Trip Computer Display Screen .....</b>	<b>70</b>		
<b>Type-I Trip Computer Display Screen Switch .....</b>	<b>76</b>		
<b>Control Indicators.....</b>	<b>78</b>		
• Type-I Instrument Cluster .....	78		
• Type-II Instrument Cluster .....	80		
• Turn Signal Lamp / Hazard Warning Indicator .....	82		
• Engine Oil Pressure Too Low Warning Lamp .....	82		
• Charging System Warning Lamp .....	83		
• Coolant Temperature Too High Warning Lamp .....	84		
• Front Fog Lamp Indicator*.....	84		
• Rear Fog Lamp Indicator .....	84		
• Headlamp High Beam Indicator .....	85		
• Position Lamp Indicator .....	85		
• Engine Malfunction Indicator Lamp (MIL).....	85		
• ABS Fault Warning Lamp .....	86		
• EPS Fault Warning Lamp .....	87		
• Airbag Fault Warning Lamp.....	87		
• Brake System/EBD Warning Lamp.....	88		
• Engine Immobilizer System Indicator .....	89		
• Driver Fasten-Seat-Belt Warning Lamp .....	90		
• Front Passenger Fasten-Seat-Belt Warning Lamp*.....	90		
• Fuel Level Too Low Warning Lamp .....	90		
• Electronic Parking Brake (EPB) Working Indicator* .....	91		
• Electronic Parking Brake (EPB) Fault Warning Lamp* .....	91		
• Automatic Vehicle Hold (AVH) Working Indicator* .....	92		
• Automatic Vehicle Hold (AVH) Fault Warning Lamp* .....	92		
• ESC Fault Warning Lamp .....	93		
• ESC OFF Indicator .....	93		
• Transmission Fault Warning Lamp* .....	93		
• Emergency Parking (EP) Indicator* .....	94		
• Cruise Control System Working Condition Indicator*.....	94		
• TPMS Fault Indicator* .....	95		
• Overspeed Warning.....	95		
• Vehicle - Start / Stop Fault Indicator .....	95		
• SCR (Selective Catalytic Reduction) .....	96		
• Diesel Particulate Filter Indicator .....	96		
• Fuel Water Indicator Light* .....	96		
• Engine Hood Open Indicator* .....	97		
• Glow Plug Indicator* .....	97		
• 48v System Failure Warning Light* .....	97		
<b>Reverse Sensor* .....</b>	<b>98</b>		
• Reverse Video Display* .....	99		
<b>Parking Assist System* .....</b>	<b>100</b>		
• 360 Degree Panoramic Parking Screen Assist* .....	101		
• Parking Image Assist during Reversing ...	102		

## Instrument Panel

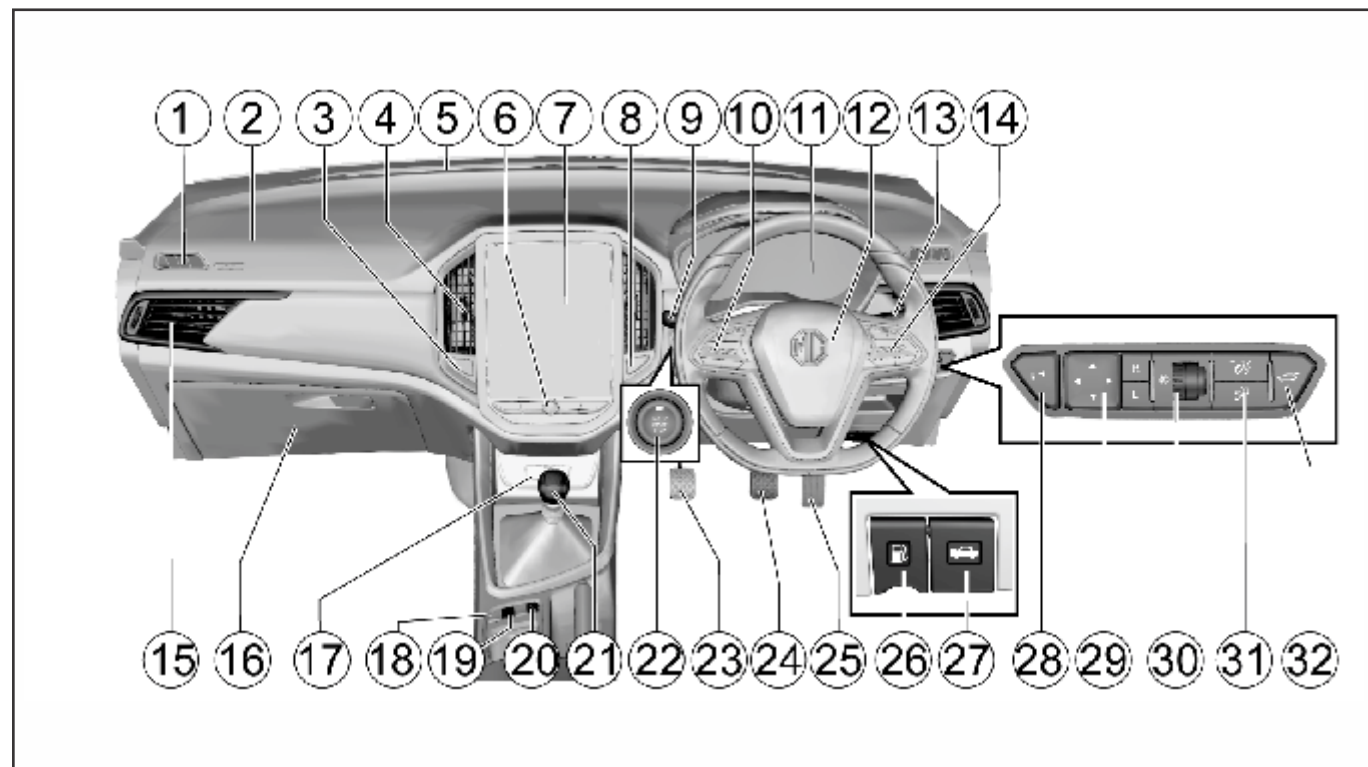



1. Front window defroster vent
2. Front passenger airbag
3. ESC OFF switch
4. Central air vent
5. Front air outlet
6. Control panel
7. Infotainment System
8. Hazard warning light switch
9. Wiper and washer switch
10. Fixed speed cruise control button\*
11. Instrument Cluster
12. Driver airbag / horn switch
13. Headlights, turn signal switches
14. Sound system control button\*
15. Side air outlet
16. Glove box
17. Entertainment system external interface
18. Start and stop system switch\*
19. 360 degree panoramic parking screen switch\*
20. Parking assist system switch\*
21. Gear Knob
22. Ignition switch\*
23. Clutch pedal\*
24. Brake pedal
25. Accelerator pedal
26. Fuel filler cap release handle
27. Hood release lever
28. ORVM folding switch\*
29. Electrically operated ORVM adjustment switch
30. Headlight beam adjustment regulator
31. Instrument Cluster brightness adjustment switch\*
32. Tailgate opening switch\*

## Controls

### Horn

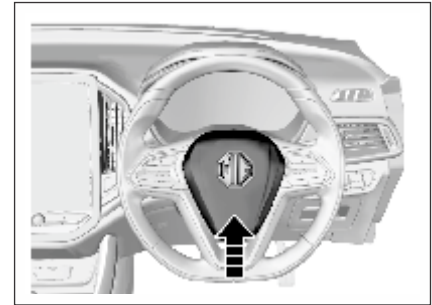

Press the switch on the steering wheel to blow the horn.

### Steering Wheel Adjustment\*

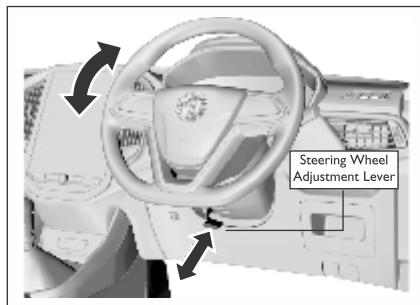

It is only allowed to adjust the steering wheel after the vehicle has fully stopped. The steering wheel can tilt up / down and towards / away.

If you need to adjust the steering wheel:

1. As is shown in the figure, push the steering wheel adjustment lever downward first;
2. Adjust the steering wheel to the desired position (either down and away or down and toward you) and then pull back the adjustment lever to lock the steering wheel;
3. Check and confirm that the steering wheel has been locked firmly.

### Caution

The driver must keep absolute control of the steering wheel during driving. It is not allowed to adjust the steering wheel while the vehicle is running. Adjusting the steering wheel during driving can cause the vehicle out of control.

### Front Windshield Wiper and Washer\*

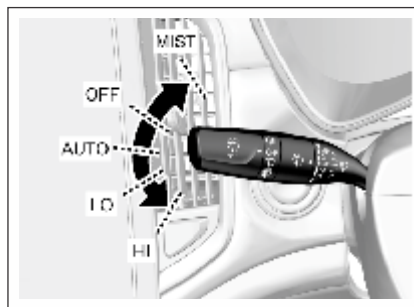

To use the front windshield wiper, turn on the ignition switch first and then push the windshield wiper / washer control lever. The front windshield wiper has the following 5 working positions:

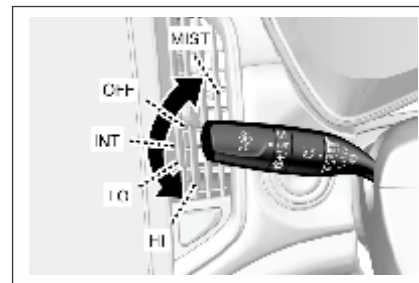

**MIST:** Push the control lever up once and the wiper wipes once.

**OFF:** Turn the system off.

**AUTO\*:** This feature senses rain or snow fall on the windshield and automatically activates the wipers for the driver.

**LO:** Push the control lever down to this position and the wiper wipes continuously at a low speed.

**HI:** Push the control lever down to this position and the wiper wipes continuously at a high speed.

**INT\*:** This feature sweeps the windscreen at regular intervals as configured.

The intermittent and automatic wiping speed is adjustable and to select the desired speed, just turn the circular knob in the middle of the control lever.

### Front Windshield Washer

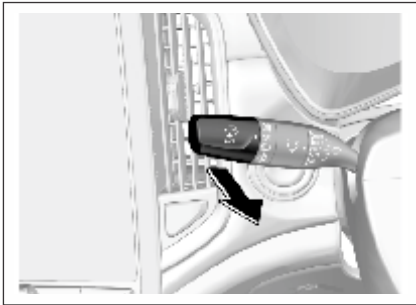



To spray cleaning fluid on the front windshield:

- Turn the ignition switch to “ON (connected)” position;
- Pull the windshield wiper/washer control lever towards the steering wheel.

Keep pulling the control lever for more than 1s or so—the washer sprays cleaning fluid to the windshield and works for 3 cycles or until the control lever is released.

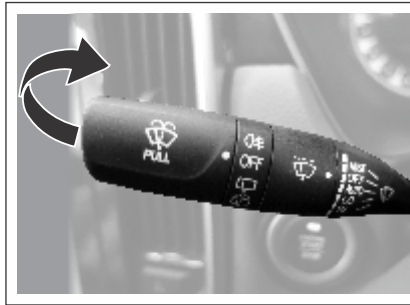
### Rear Windshield Wiper and Washer\*



To use the rear windshield washer, turn the ignition switch to “ON” position first and then turn the rear wiper and washer switch knob to .

Turn the rear wiper and washer switch knob to  and the water pump sprays water to the rear windshield immediately. Release the knob and the pump stops spraying.

### Exterior Entertainment Power Outlet\*



The entertainment system interface is located below the air conditioning panel. USB interface specification is 5V/2A, can be connected to play audio, charging.

Power will not be available for charging when the vehicle ignition switch is off.

### Caution

- **Blurred view for the driver can lead to accident and cause personal injuries and damage to the vehicle or other properties.**
- **In cold weather, if the wiper gets frozen, before using the wiper, please spray warm water on the frozen area to device and then wipe off the water immediately to prevent icing.**

**Rear Accessory USB Power Outlet\***

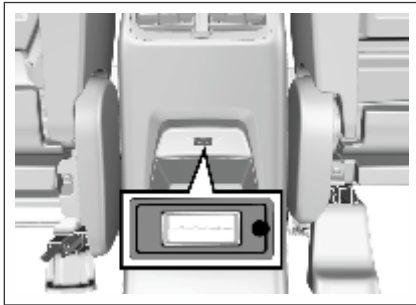

The second-row USB power outlet (5V/2A) is located at the rear end of the console and it can be used for cellphone charging. The power outlet is unavailable if the ignition switch is turned off.

If equipped, the third-row USB power outlet is located at the third-row seat right armrest.

**Driving Recorder USB Power Outlet**

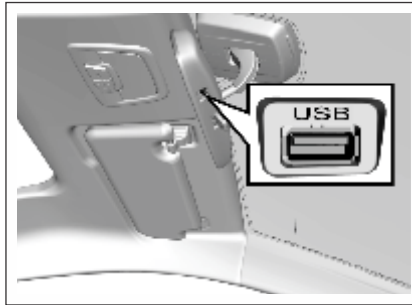

The driving recorder is located at the bottom of the inside rearview mirror and it can provide power supply for your driving recorder.

**Rear Power USB Port \***



There is USB power jacks (5V/2A) available for the second and third row seat and can be used for charging mobile phones. The power is not available when the vehicle ignition switch is off. Warning Lamps, Gauges and Indicators

## Warning Lamps, Gauges and Indicators

### Speedometer



It displays the vehicle speed.

#### Note

Please keep the speed within the limit when driving in a speed limit zone.

#### Note\*

Speedometer and Engine RPM Needle may vibrate for approx 15 - 30 seconds after ignition off. This is normal phenomenon\*.

### Tachometer

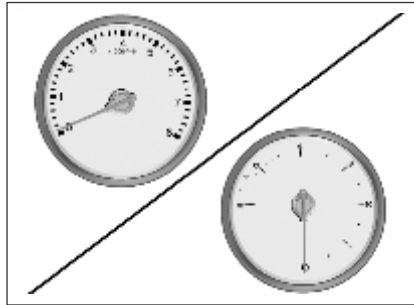

It displays the engine crankshaft revolutions per minute.

### Fuel Gauge

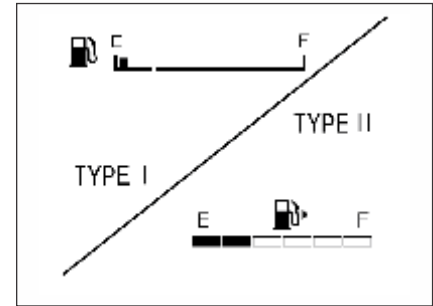

It displays the fuel level in the fuel tank.

If the fuel level in the fuel tank is too low, the control indicator will illuminate. Please add fuel immediately. It is strictly prohibited to use up the fuel in the fuel tank.

As some fuel remains in the fuel tank, the adding amount can be less than the fuel tank capacity. During braking, acceleration or cornering, as the fuel in the fuel tank shakes, indication on the fuel gauge fluctuates.

#### Dangers

Before adding fuel, please do stop the vehicle and shut down the engine.

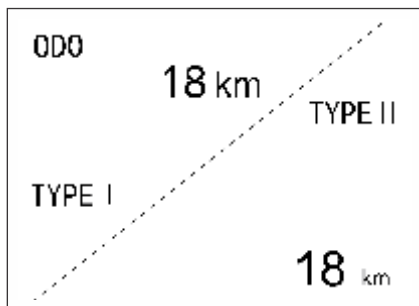
**General Odometer**

It displays the total accumulated kilometers of the vehicle.

**Note**

**It is lawfully forbidden to adjust the odometer for illegal purpose.**

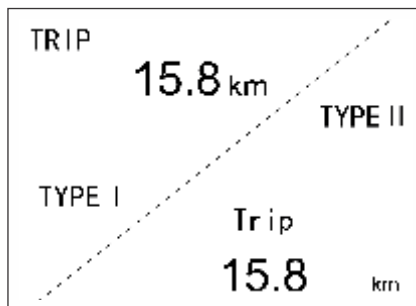
**Small Odometer**

It shows vehicle kilometers for a driving trip After it has been reset to zero. In this mode, long press the adjustment lever to clear the trip distance.

You can clear the trip distance when it is displayed on the small odometer. To do this, long press “OK” button on the steering wheel if the vehicle is of high configuration; long press the instrument cluster adjustment lever if the vehicle is of low configuration.

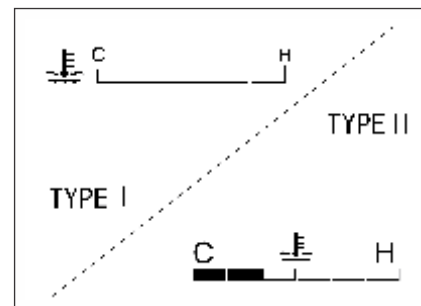
**Engine Coolant Temperature Gauge**

It displays the temperature of the engine coolant.

“C” means “cold state” and “H” means “hot temperature”; when the coolant temperature gauge indicates within the red area, it indicates the engine is overheated. Please shut down the engine immediately for inspection.

**Caution**

If the engine coolant temperature is too high, please stop the vehicle, shut down the engine and inspect the coolant level.

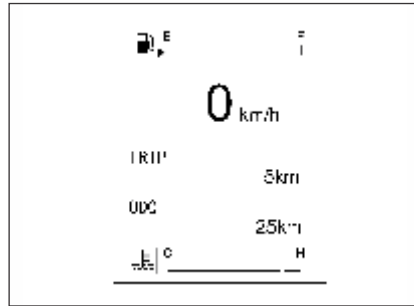
**Type-I Trip Computer Display Screen**

The trip computer monitor is located between the tachometer and the speedometer. It can display fuel gauge, engine coolant temperature gauge, general odometer, small odometer, fuel range, depending on the vehicle configuration.

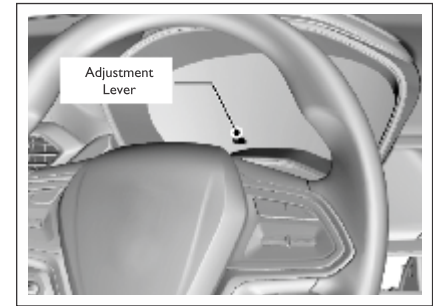
**Adjustment Lever**

Short press or long press the adjustment lever to switch among different screens or carry out zeroing.

Long press means press for over 2s and short press means press for 2s or less.

Rotate the adjustment lever to adjust the display brightness of the instrument cluster.

For more details, please refer to “Display Screen Mode Switch”.

### Mobile Phone Wireless Charging System

If your vehicle is equipped with a mobile phone wireless charging system, the system can achieve wireless charging of mobile phones through electromagnetic induction, without the need for a wire connection.

#### Note

**The mobile phone wireless charging system is not applicable for all mobile phones, only for "Qi" certified phones.**

### Mobile phone wireless charging failure

If a failure occurs during charging, it may be caused by the following:



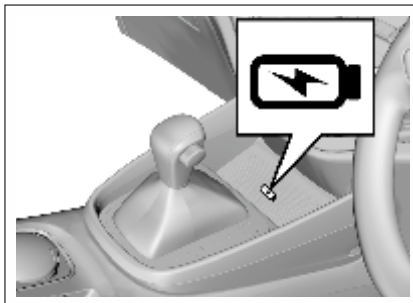

- The vehicle battery voltage is too low.
- A metal foreign object exists in the charging area. Please take the phone away to check if there is any foreign object. If so, remove the foreign object and place the phone in the charging area again.
- The temperature is too high.
- There is an internal failure in the mobile phone wireless charging system.
- The mobile phone is malfunctioning.

### Operation of Mobile Phone Wireless Charging



Please put the phone in the center of the charging board to charge the phone, if the phone is moved out of the appropriate area, the charging may stop.

Charge icons on status bar:

- Charging 
- Charging completed 
- Charging stopped / unable to charge 
- Metal foreign body warning 

#### Note

**The mobile phone wireless charging module may stop working when the low frequency antenna of the keyless start system is searching for keys.**

### Caution

**When the driver leaves the vehicle, please do not place the mobile phone in the vehicle for charging, so as to avoid potential safety hazards. During charging, do not leave metal foreign objects such as coins, keys, chip cards, etc. in the charging area, which may cause the metal to be heated, resulting in failure to charge and safety accidents. Only one phone can be charged at a time. Do not spill water on the charging area to avoid water entering the wireless charger through the gaps in the rubber pad and causing the charger malfunction. Charging of the phone may stop when the temperature is too high, and will continue to charge when the temperature drops.**



## Type-II Trip Computer Display Screen

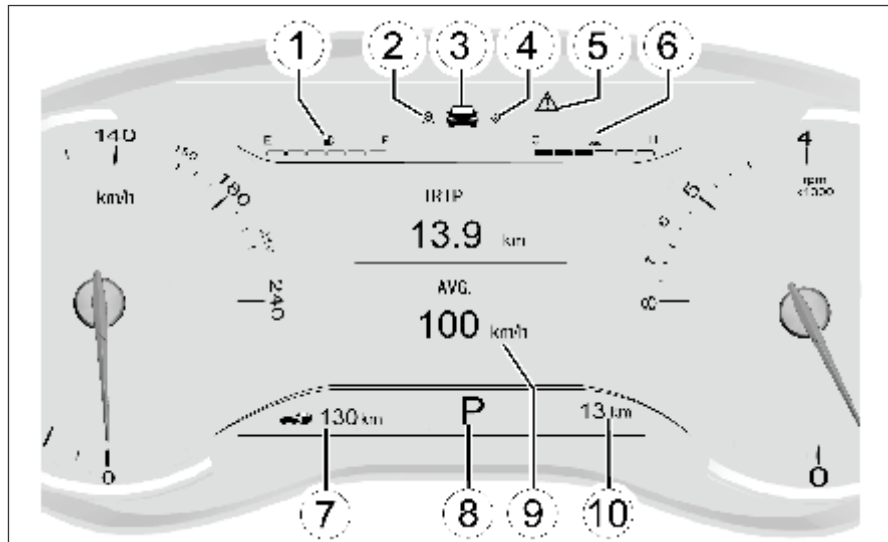

- |  |   |
|--|---|
| 1. Fuel Level                            | 7. Distance To Empty (Range)                          |
| 2. Navigation Information Display Option | 8. Gear Position Display* (equipped on AT model only) |
| 3. Vehicle Information Setup Option      | 9. Display Zone                                       |
| 4. Settings                              | 10. General Odometer                                  |
| 5. Warnings                              |   |
| 6. Coolant Temperature                   |   |

### Instrument Cluster Control Button\*

Type-II trip computer display screen can be controlled with the control button on the steering wheel. Only when the ignition switch is turned to ON can the instrument cluster be controlled.

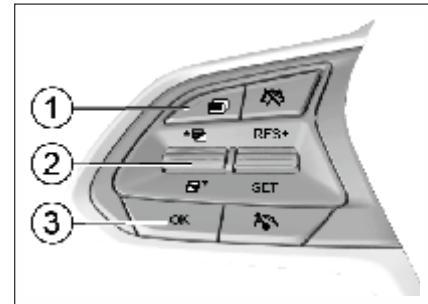

- Option switch button  
It is used to switch among different display screens.
- Up/down selection button  
Pull it up or down to make selection or adjustment.
- Confirm button (OK)  
It is used to confirm the setup or to clear the trip mileage. The confirm button can be

operated in two ways: short press (<2S) and long press (>2S).

### Trip Computer Information Option

Choose this option to indicate driving information such as odometer, current vehicle speed, driving time, fuel range, tyre pressure, etc. Pull the up/down selection button to switch among the following interfaces:

#### Interface - 1

##### Trip / Average Speed



The first trip mileage within the recent driving distance are shown.

#### Interface - 2

##### Tyre Pressure Indication

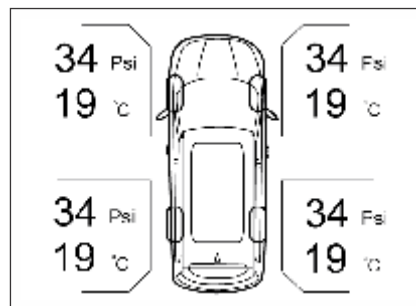

The Tyre Pressure Monitor System (TPMS) displays the current pressure and temperature of the four tyres respectively.

When the system detects tyre pressure low or high, it gives a prompt, asking you to adjust the tyre pressure in time. For the standard tyre pressures, please refer to "Technical Data".

If the tyre temperature value becomes extremely great, for example, when you are driving down a slope and applies the brake frequently, please stop the vehicle to cool down the tyres. If the shown tyre temperature value becomes abnormal, please contact the Service Center as soon as possible for inspection and repair.

#### Note

Please keep the tyre pressure within the reference range, otherwise the tyre service life and vehicle controllability can be reduced, or flat tyre can happen which is very dangerous. Please do not continue driving if the tyre temperature is extremely high. Once overheated, the brake may fail to provide sufficient braking force and the tyre may become flat. Please stop the vehicle as soon as possible to cool down the tyre and carry out inspection.

## Interface - 3

### Driving Time / Fuel Range



Calculation of the driving time starts as the vehicle starts running and ends as the vehicle stops. The indication can be 23 hours plus 59 minutes at maximum.

After the driving time reaches the maximum record value, or when the battery gets disconnected, or the engine flameout condition lasts for 2 hours, the driving time will clear automatically and calculation starts anew.

The displayed fuel range is calculated based on the current fuel consumption and the fuel amount left in the fuel tank. It changes as the driving condition changes. When the fuel level low warning indicator illuminates, “fuel

insufficient, add fuel” will appear in the fuel range indication area. If you long press “OK” on the current interface, the driving time will be cleared, while the fuel range cannot be cleared.

### Vehicle Information Setup Option



This option allows access to fault information inquiry, overspeed warning setup, fatigue driving setup and display language setup.

Pull the up/down selection button and then press “OK” to enter the interface under this option.

The control button on the steering wheel will be shielded as a warning message pops out on the display screen. The control button will give no response even though it is pressed until the warning message disappears.

## Interface - I

### Fault Information Inquiry

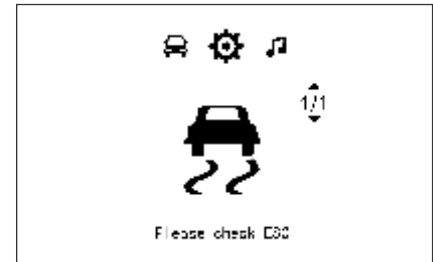

Press “OK” and you will enter the fault information inquiry interface. If no fault information is shown, a prompt saying no fault information exists will appear on the LCD; if any fault information is shown, you can check it one by one by pushing the up/down selection button.

Press “OK” to return to the parent directory.

If any fault exists at the time of vehicle start, a fault warning will appear and last for 5s. Please contact the Service Center for inspection and repair.

When the icon under this option changes to what is shown above, it indicates a vehicle fault to which you should keep alert. Please contact the Service Center in time for inspection and repair so as to eliminate the safety hazard.

## Interface - 2

## Fatigue Driving Warning Setup



Enter the fatigue driving function setup interface and you can make fatigue driving function setup. Once the driving time reaches or exceeds the set value, a text warning message will appear on the LCD, accompanied by a sound alarm. The system reminds you to have a rest if necessary in this way. You can also disable the fatigue driving function by selecting the corresponding option on this interface. The fatigue driving function gets disabled by fault once the battery power is cut off.

Set range of fatigue driving warning: 1 h~ 4 h at an increment/decrement of 0.5 h.

## Multimedia Information Option



Choose this option and the instrument cluster will show AM, FM or audio information real-time on the screen. If the instrument cluster has not connected to the relevant system, "Connecting Multimedia" will appear on the screen.

## Bluetooth Telephone Information Option



Choose this option and the Bluetooth telephone interface will appear. If the instrument cluster has not connected to Bluetooth telephone, "Telephone Not Connected" will appear on the screen. After successful connection, "Telephone Connected" will appear on the screen.

The instrument cluster will show the current state of Bluetooth telephone on the screen: "incoming call", "outgoing call" and "on the line".

In addition, the instrument cluster will also show the current telephone number and name of the contact on the screen.

**Navigation Information Option**



Choose this option and the instrument cluster will show “road name”, “destination” “distance information” or indication icon on the screen, depending on the current state of the navigation system.

If the instrument cluster has not connected to the navigation system, “Connecting Navigation” will appear on the screen.

**Gear Position Display\*  
(Equipped on AT Model Only)**



The automatic transmission has two control types: manual and automatic, displayed as “M” and “A” respectively.

Gear position display prompt includes two parts: mode prompt and gear position prompt. In automatic (A) mode, two transmission control modes are available: economy and sports, displayed as “E” and “S” respectively.

In automatic (A) mode, three gear positions will be displayed: D, R and N.

In manual (M) mode, the following gear positions will be displayed: 1, 2, 3, 4, 5, 6 (if equipped), R and N. When driving in this mode, you will be reminded to shift up as the vehicle speed reaches certain value and at the

same time, the arrow icon (↑) in the gear position display area will illuminate.

For more details, please refer to “Automatic Transmission” in the driving and control section.

**Door Ajar Warning Lamp**

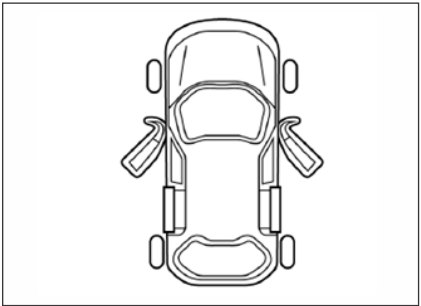

If any door in the front or rear row is ajar or not fully closed, a warning lamp shaped like the door ajar will illuminate; if the liftgate is ajar or not fully closed, a warning lamp shaped like a liftgate ajar will illuminate or flash.

If any door is not fully closed while the vehicle is running at a speed of 10 km/h, a door ajar alarm sound will be issued.

## Instrument Cluster Display Brightness Adjustment

### Type - I Instrument Cluster\*



Turn the adjustment lever to set the desired display brightness. After adjustment, if no operation is conducted within 2s, the system will turn back to the previous interface.

### Type - II Instrument Cluster\*

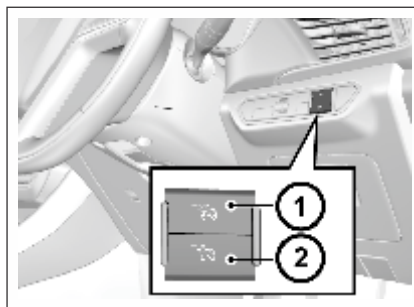

For high-configuration models, a backlight brightness adjustment button is set at the left side of the instrument panel.

Turn the ignition switch to ON position and then press the backlight adjustment button to set backlight brightness of the instrument cluster.

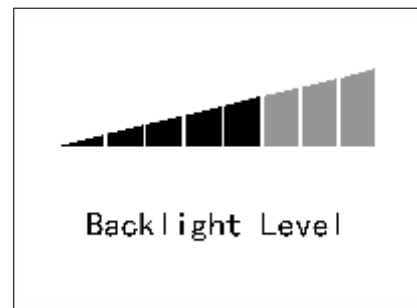

As it is shown in the figure, the current backlight brightness will be shown on the LCD as you make the adjustment. If no operation is conducted within several seconds, the system will save the setup and turn back to the previous interface. When the position lamp is switched on, the backlight brightness will decrease automatically.

### Type - I Trip Computer Display Screen Switch

If the vehicle is equipped with a Type-I trip computer display screen, you can short press or long press the adjustment lever on the instrument cluster to switch the display modes or conduct clearing. As it is shown in the figure:

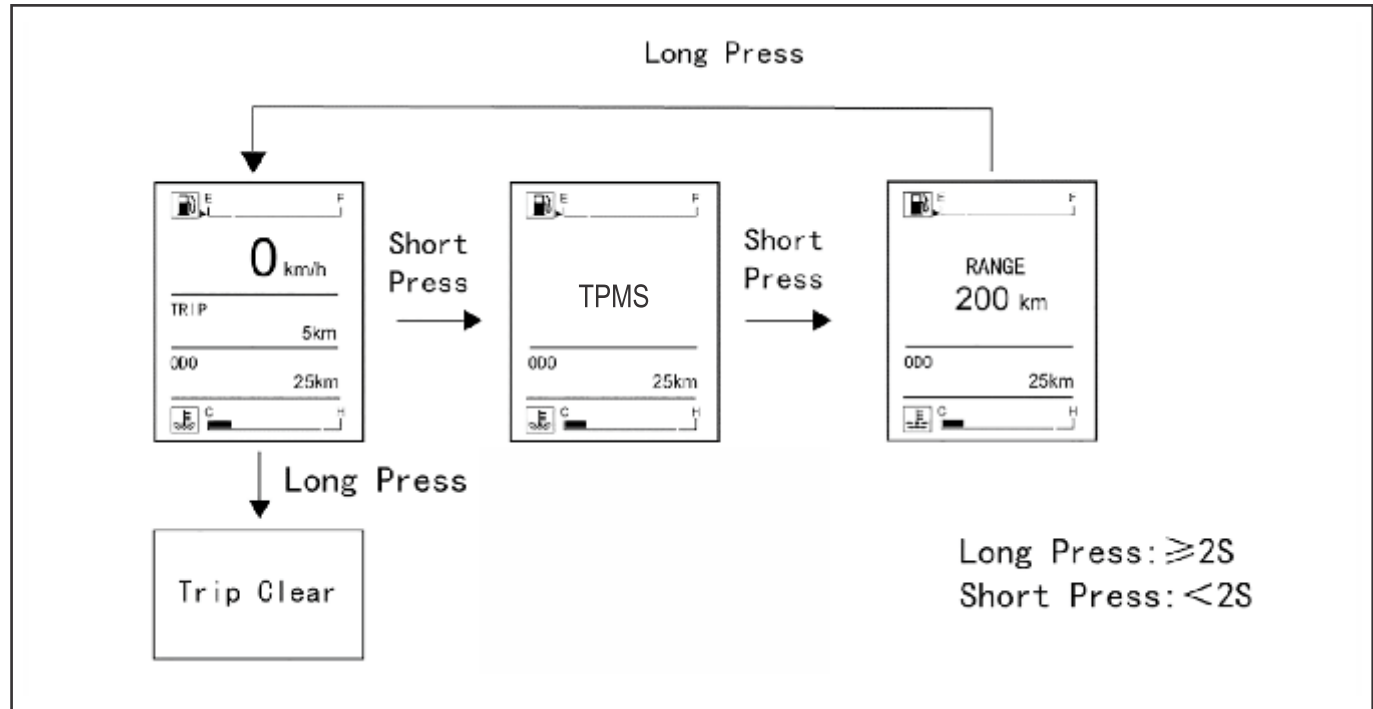

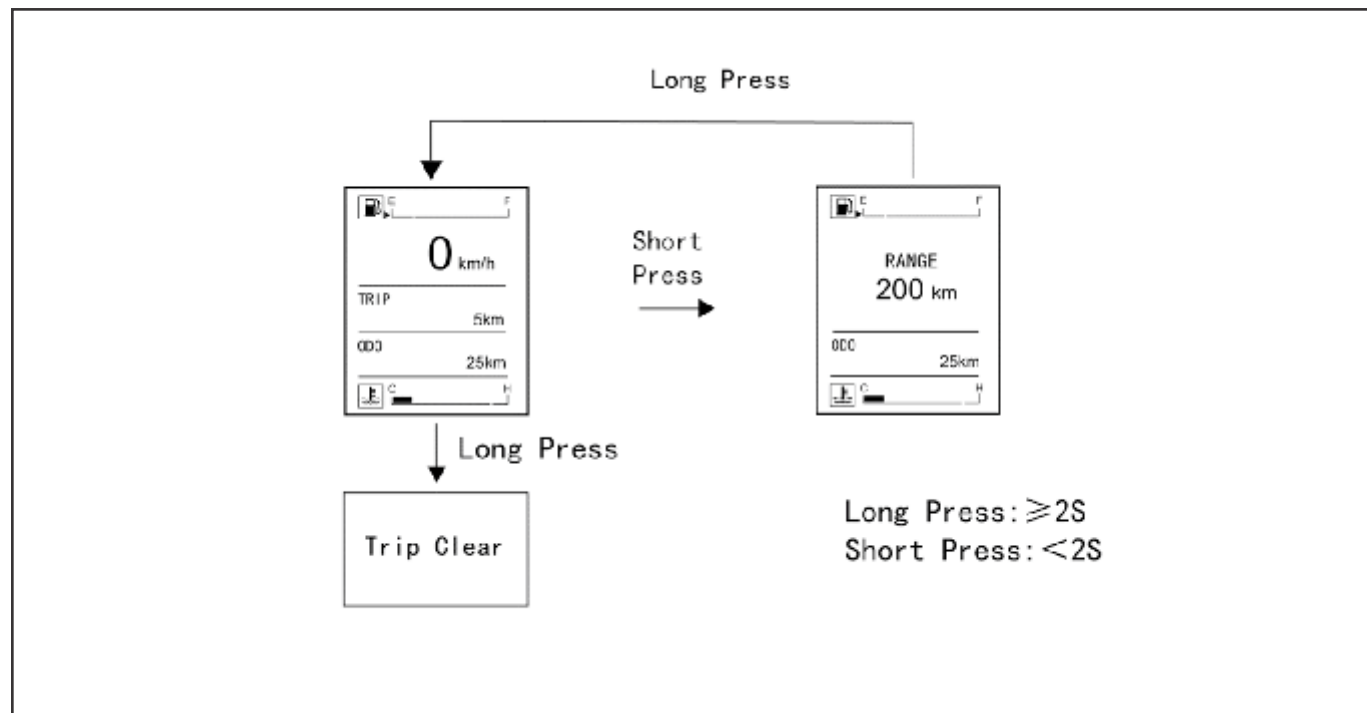



**Control Indicators****Type - I Instrument Cluster**

If the vehicle is equipped with a Type-I trip computer display screen, you can short press or long press the adjustment lever on the instrument cluster to switch the display modes or conduct clearing. As it is shown in the figure:

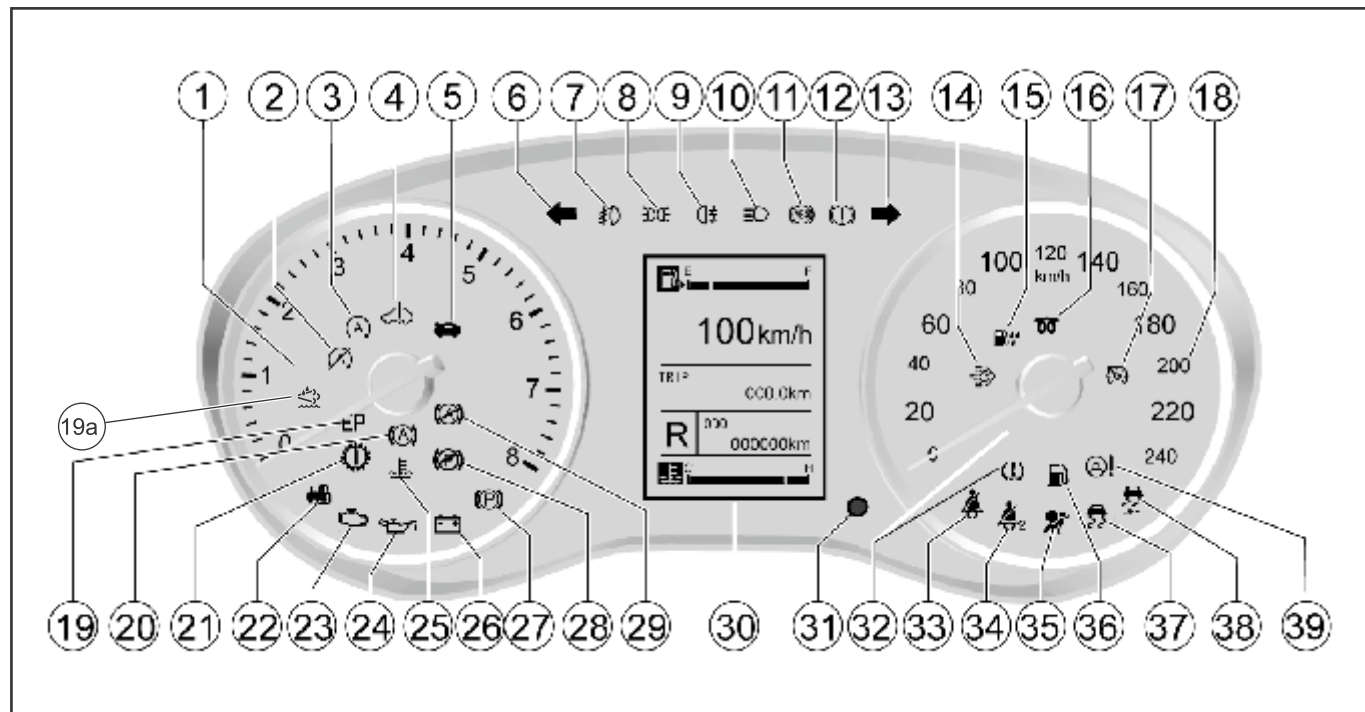

## INSTRUMENTS AND CONTROLS

1. Engine Tachometer
2. Start And Stop System Shutdown Indicator\*
3. Start And Stop System Work Indicator\*
4. 48v System Failure Warning Light\*
5. Engine Compartment Opening Indicator\*
6. Left Turn Signal / Hazard Warning Indicator
7. Front Fog Light Indicator\*
8. Position Light Indicator
9. Rear Fog Light Indicator
10. Headlights High Beam Indicator
11. Abs Failure Warning Light
12. Brake System / Hand Brake Indicator / Ebd Warning Light
13. Right Turn Signal / Hazard Warning Indicator
14. Particle Trap Indicator Light\*
15. Fuel Water Indicator Light\*
16. Glow Plug Indicator Light\*
17. Fixed Speed Cruise Work Status Indicator\*
18. Speedometer
19. Emergency Stop Light\*
- 19a. SCR (Selective Catalytic Reduction) Warning Light
20. Automatic Parking (avh) Work Indicator\*
21. Transmission Fault Warning Light\*
22. Engine Anti-theft System Indicator / Immobilizer
23. Engine Failure Warning Light Mil
24. Oil Pressure Is Too Low Warning Light
25. Engine Water Temperature Is Too High Warning Light
26. Charging System Fault Warning Light
27. Electronic Hand Brake Work Indicator\*
28. Electronic Hand Brake Failure Warning Light\*
29. Automatic Parking (avh) Fault Warning Light\*
30. Driving Computer Display
31. Display Adjustment Lever
32. Tyre Pressure Monitoring System (tpms) Failure Warning Light\*
33. Driver Side Seat Belt Warning Light
34. Passenger Side Seat Belts Warning Lights\*
35. Airbag Failure Warning Light
36. Fuel Level Low Warning Light
37. Electronic Stability Control (esc) Fault Alarm Notice Light
38. Electronic Stability Control System (esc) Shutdown Refers To Light
39. Electronic Power Steering (eps) Fault Warning Light

When the ignition switch is turned on, it is used as a function test.

Most control lights will be activated for a short time bright.

The Control Indicator Color Means:

Red = Dangerous, Important Reminder.

Yellow = Warning, Message, Fault.

Green = Confirm Enable.

## Type - II Instrument Cluster

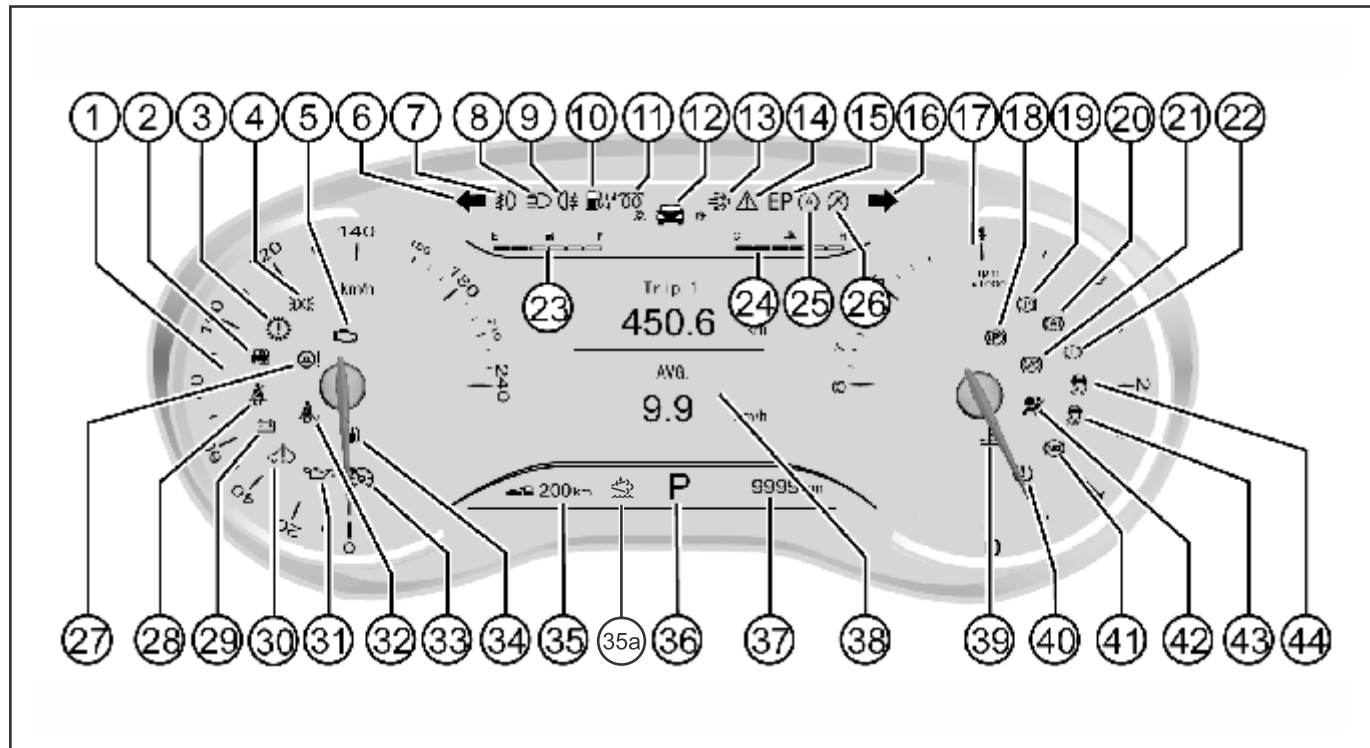

## INSTRUMENTS AND CONTROLS

1. Speedometer
2. Engine anti-theft system indicator / Immobilizer
3. Transmission Failure Warning Light\*
4. Position Light Indicator
5. Engine Failure Warning Light
6. Left Turn Signal / Hazard Warning Indicator
7. Front Fog Light Indicator\*
8. Headlights High Beam Indicator
9. Rear Fog Light Indicator
10. Fuel Water Indicator Light\*
11. Glow Plug Indicator Light\*
12. Driving Computer Information Tab
13. Particle Trap Indicator Light\*
14. Fault Information Prompt
15. Emergency Stop Light\*
16. Right Turn Signal / Hazard Warning Indicator
17. Engine Tachometer
18. Electronic Hand Brake Failure Warning Light\*
19. Electronic Hand Brake Work Indicator\*
20. Automatic Parking (AVH) Work Indicator\*
21. Automatic Parking (AVH) Fault Warning Light\*
22. Brake System / Hand Brake Indicator / EBD Warning Light
23. Oil Gauge
24. Water Temperature Gauge
25. Start and Stop System Work Indicator\*
26. Start And Stop System Shutdown Indicator\*
27. Electric Power Steering (EPS) Warning Light
28. Driver side Seat Belt Warning Light
29. Charging System Failure Warning Light
30. 48v System Failure Warning Light\*
31. Low Oil Pressure Warning Light
32. Passenger side Seat Belts Warning Lights
33. Constant Speed Cruise Work Status Indicator\*
34. Fuel Level Low Warning Light
35. Distance to empty (Fuel range)
- 35a. SCR (Selective Catalytic Reduction) Warning Light
36. Gear Display\*
37. Total Odometer
38. Display
39. Water Temperature Warning Lamp
40. Tyre Pressure Monitoring System (TPMS) Fault Indication light\*
41. ABS Warning Light
42. Airbag Failure Warning Light
43. Electronic Stability Control System (ESC) shutdown refers to Light\*
44. Electronic Stability Control (ESC) Fault Alarm Notice light\*

When the ignition switch is turned on, it is used as a function test.

Try, most control lights will be activated for a short time bright.

Control indicator color one position:

Red = dangerous, important reminder.

Yellow = warning, message, fault.

Green = Confirm Enable.

Blue = Confirm Enable.

### Turn Signal Lamp / Hazard Warning Indicator

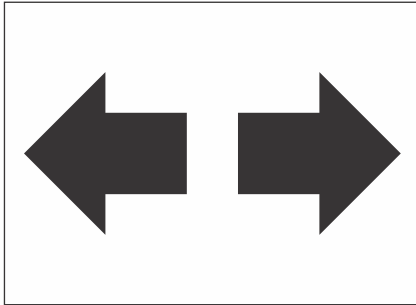

The turn signal lamp / hazard warning lamp indicator is used to confirm whether the outside turn signal lamp / hazard flasher can work normally. If you find that the green arrow does not flash as you send a turning signal or press the hazard warning button, please inspect the fuse and bulb and if necessary, replace them.

#### Caution

These indicators are essential for assurance of driving safety. If the turn signal lamp or the hazard flasher indicator bulb has burnt out, please replace it immediately. If you fail to keep these indicators in an agreeable working condition, accident may happen and as a result, personal injuries, and damage to the vehicle or other properties can occur.

#### Note

If the flashing time is shorter than normal, it indicates that the turn signal lamp bulb has burnt out and must be replaced.

### Engine Oil Pressure Too Low Warning Lamp

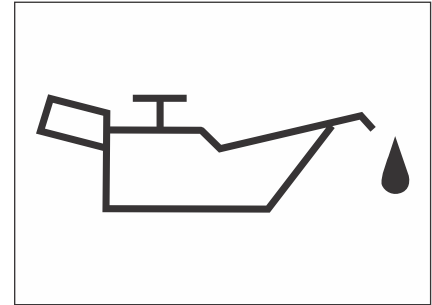

As you turn on the ignition switch, the engine oil pressure too low warning lamp illuminates and it goes out after the engine gets started. This indicates that the indicator bulb can work normally.

If this warning lamp illuminates while the engine is running, it indicates that the engine oil pressure may have dropped to a dangerous level. Please stop the engine and check the oil level immediately.

If the oil level is too low, please add the specified engine oil to the appropriate level. Please refer to the information about engine oil level check provided in "Vehicle Maintenance". If the oil level is normal, please

go to the nearest MG Authorised Service Center to check the lubrication system.

### Caution

**When the engine oil pressure too low warning lamp illuminates, it indicates that the engine oil pressure may have dropped to a dangerous level. Please do not drive the vehicle when the warning lamp has illuminated. Otherwise, the repair charge will be expensive.**

### Charging System Warning Lamp

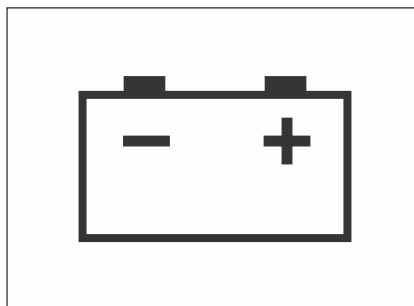

This warning lamp illuminates as you turn on the ignition switch. It goes out as the engine gets started. If the charging system warning lamp illuminates during driving:

1. Drive the vehicle off the lane in a safe manner.
2. Stop the vehicle.
3. Check and confirm that the drive belt has not loosened or broken.
4. If the drive belt is normal but the charging system warning lamp keeps illuminated, it can indicate a charging system fault. We advise you to go to the nearest MG Authorised Service Center for vehicle repair as soon as possible.

### Note

**If the charging system warning lamp illuminates, it may indicate a charging system fault.**

**Please do not drive the vehicle when the charging system warning lamp has illuminated, otherwise the vehicle can be damaged.**

### Note

**If you often drive the vehicle for short trips, the battery capacity consumes more quickly, so it is necessary to replenish the electric energy by charging the battery or having a long trip.**

### Coolant Temperature Too High Warning Lamp

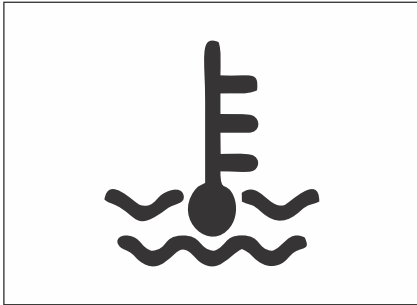

This warning lamp illuminates as you turn on the ignition switch and it goes out several seconds later. It indicates that both the system and the indicator bulb can work normally.

This indicator illuminates when the coolant temperature becomes excessively high. It indicates that the engine has over heated. Please do not continue driving the vehicle.

### Front Fog Lamp Indicator\*

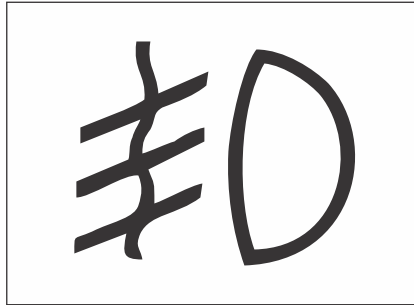

This indicator illuminates when the front fog lamp is turned on. Refer to “Front Fog Lamp” in the lighting section.

### Rear Fog Lamp Indicator

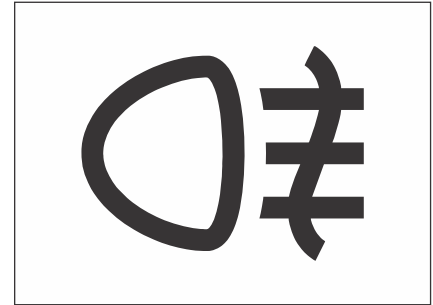

This indicator illuminates when the rear fog lamp is turned on. Refer to “Rear Fog Lamp” in the lighting section.

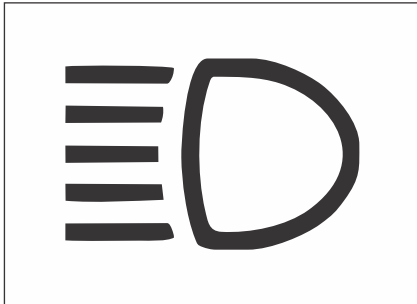
**Headlamp High Beam Indicator**

The high beam indicator illuminates when the headlamp high beam is turned on.

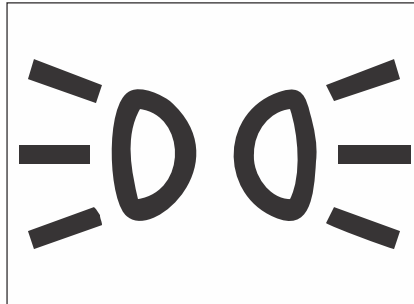
**Position Lamp Indicator**

This indicator illuminates when the position lamp is turned on.

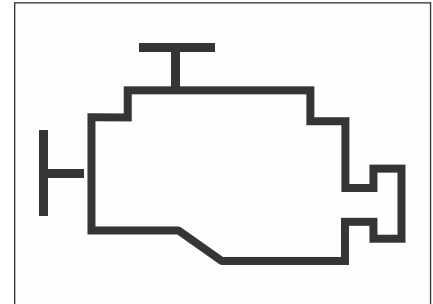
**Engine Malfunction Indicator Lamp (MIL)**

This indicator lamp illuminates when the ignition switch is turned on but the engine has not started. This indicates that the indicator lamp bulb can work normally. The lamp goes out after the engine is started. This malfunction indicator lamp (MIL) illuminates upon occurrence of any component or subsystem fault related to the emission system. Once the electronic control module (ECM) detects any fault, the malfunction indicator lamp will keep illuminated. In case that serious misfire is detected, the malfunction indicator lamp will flash constantly. Serious misfire can cause damage to the catalytic converter. In case of this, the electronic system of the vehicle will switch to



an emergency running procedure so that you can continue the trip. However, we advise you to go to the nearest MG Authorised Service Center for fault removal as soon as possible. If MIL illuminates for a while and then goes out, it is normal, not indicating any system fault.

### Caution

**If MIL illuminates, it indicates a fault that must be noted. Continuous driving after MIL has illuminated can cause damage to the emission control system, and reduce fuel economy and vehicle controllability. We advise you to go to the nearest MG Authorised Service Center for vehicle repair as soon as possible.**

### ABS Fault Warning Lamp

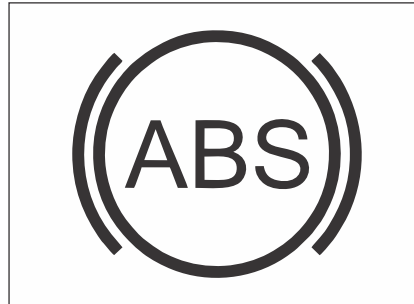

The ABS warning lamp will illuminate immediately the ignition switch is turned on. It indicates that the system is conducting self-inspection and the warning lamp bulb can work normally. The warning lamp goes out several seconds later.

When the ABS warning lamp gets into the following states, please consult the nearest MG Authorised Service Center.

- Not illuminated as the ignition switch is turned on
- Always illuminated
- Illuminated during driving

If the ABS warning lamp illuminates during driving, it indicates possibility of an ABS fault. Though the vehicle can run normally without ABS function, but we strongly advise you to go to the nearest MG Authorised Service Center for ABS inspection and necessary repair.

### Caution

**Illuminated ABS warning lamp can also indicate that the brake cannot work normally. If you fail to keep the brake in an agreeable working condition, collision may happen and as a result, personal injuries, and damage to the vehicle or other properties can occur.**

### EPS Fault Warning Lamp



This warning lamp will illuminate immediately the ignition switch is turned on. It indicates that the system is conducting self-inspection and the warning lamp bulb can work normally. The warning lamp goes out several seconds later.

When the electronic power steering (EPS) system detects a fault, the warning lamp will give out an indication. The vehicle can still steer even the steering system has a fault, but it demands much greater effort. In case of the following circumstances, please consult the nearest MG Authorised Service Center.

- The lamp does not illuminate when the ignition switch is turned on.
- The lamp does not go out after it illuminates.
- The lamp illuminates during driving.

#### Caution

**Illuminated ABS warning lamp can indicate that the electronic power steering column cannot work normally. If you fail to keep the steering column in an agreeable working condition, collision may happen and as a result, personal injuries, and damage to the vehicle or other properties can occur.**

### Airbag Fault Warning Lamp



The airbag warning lamp illuminates when the ignition switch is turned on and it goes out several seconds later. This indicates that both the warning lamp bulb and the airbag system can work normally.

In case of an airbag fault, the warning lamp will give out indication in any of the following ways:

- The lamp does not illuminate when the ignition switch is turned on.
- The lamp does not go out after it illuminates.
- Flashing or keeping illuminated during driving.

#### Caution

**If the airbag warning lamp flashes or keeps illuminated during driving, it indicates an airbag system fault. The airbag system will get deactivated and thus fail to trigger off in case of an accident. We strongly advise you to drive the vehicle to the nearest MG Authorised Service Center for inspection. If an accident happens after the airbag system fault has occurred, personal injuries or even death can appear as a result.**

## Brake System / EBD Warning Lamp



### Model with Mechanical Hand Brake

The brake system warning lamp illuminates after the ignition switch is turned on and it goes out several seconds later (if the parking brake has been released). This indicates that the warning lamp can work normally.

The brake system/EBD warning lamp also illuminates when the parking brake engages. The lamp goes out after the parking brake is released. Please do not fully release the parking brake before starting the vehicle.

If the brake system warning lamp illuminates after the parking brake is fully released, it indicates the possibility that the brake fluid level in the fluid reservoir is too low or an EBD system fault has occurred.

In case of this, please operate in the following steps:

1. Carefully drive the vehicle off the lane and then stop the vehicle.
2. Check the brake fluid level.
3. Add the recommended brake fluid until the fluid level reaches MAX (highest) mark. Refer to "Adding Brake/Clutch Fluid".
4. In case of the following circumstances, we advise you to drive the vehicle at a safe speed to the nearest MG Authorised Service Center to inspect the brake and confirm that:
  - The brake can work normally.
  - You think the brake system is safe at your own judgment.
5. In case of the following circumstances, we advise you to tow the vehicle to the nearest MG Authorised Service Center for inspection and repair:
  - You discovered brake system leakage.
  - The brake system warning lamp keeps illuminated.
  - The brake cannot work normally.

### Caution

**Please do not drive the vehicle when the brake system warning lamp has illuminated. This phenomenon indicates possibility of brake failure to work normally. Driving the vehicle after a brake fault has occurred can lead to collision, causing personal injuries and damage to the vehicle or other properties as a result.**

### Model with Electronic Parking Brake

The brake system warning lamp illuminates after the ignition switch is turned on and it goes out several seconds later. This indicates that the warning lamp can work normally.

If the brake system warning lamp keeps illuminated or illuminates during driving, it indicates possibility that the brake fluid level in the fluid reservoir is too low or an EBD system fault has occurred. In case of this, the operation steps are the same as those for model with mechanical hand brake.

#### Caution

**If the brake system warning lamp does not illuminate after the parking brake engages with the ignition switch turned on, please do not drive the vehicle.**

**Please ensure that light-emitting diode of the warning lamp works normally. If the lamp does not illuminate when the parking brake engages with the ignition switch turned on, even though light-emitting diode of the warning lamp works normally, we still advise you to go to the nearest MG Authorised Service Center to inspect the brake system.**

**These phenomena indicate possibility of a brake system fault.**

**If you fail to keep the brake in an agreeable working condition, collision may happen and as a result, personal injuries, and damage to the vehicle or other properties can occur.**

### Engine Immobilizer System Indicator



This indicator illuminates when the door is opened. It goes out after the engine is started. This indicates that the indicator can work normally. Refer to information on engine immobilizer system given in “Driving and Controls”.

**Driver Fasten-Seat-Belt Warning Lamp**

The seat belt warning lamp illuminates if the driver does not fasten the seat belt properly after the ignition switch is turned on. Following this, the following circumstances will appear unless the driver fastens the seat belt properly:

- The seat belt warning lamp keeps illuminated
- If the vehicle speed exceeds 20 km/h, the warning lamp will flash and the warning buzzer will buzz for a certain time.

**Front Passenger Fasten-Seat-Belt Warning Lamp\***

The seat belt warning lamp illuminates if the front passenger seat is occupied but the occupant does not fasten the seat belt properly after the ignition switch is turned on. Following this, the following circumstances will appear unless the front passenger fastens the seat belt properly:

- The seat belt warning lamp keeps illuminated
- If the vehicle speed exceeds 20 km/h, the warning lamp will flash and the warning buzzer will buzz for a certain time.

This warning lamp does not illuminate if the front passenger seat is not occupied after the ignition switch is turned on.

**Fuel Level Too Low Warning Lamp**

This warning lamp will illuminate immediately the ignition switch is turned on. It indicates that the system is conducting self-inspection and the warning lamp bulb can work normally. If this lamp keeps illuminated after the ignition switch is turned on or it illuminates during driving, it indicates that the fuel amount in the fuel tank is insufficient and you should replenish the fuel in time.

**Note**

**Do not exhaust the fuel, otherwise the catalytic converter can be damaged.**

### Electronic Parking Brake (EPB) Working Indicator\*



The electronic parking brake (EPB) working indicator illuminates as the electronic parking brake is pulled up. This indicates that the vehicle is in a parking state.

This indicator goes out as the electronic parking brake is released. This indicates that the vehicle is out of the parking state.

This indicator keeps illuminated as long as the electronic parking brake engages firmly.

For details about the electronic parking brake (EPB), please refer to “Parking Brake” under “Driving and Controls”.

### Electronic Parking Brake (EPB) Fault Warning Lamp\*



The electronic parking brake fault warning lamp illuminates after the ignition switch is turned on and it goes out several seconds later. This indicates that both the warning lamp and the electronic parking brake function module can work normally.

In case of an electronic parking brake fault or a warning lamp fault, it will be indicated in any of the following ways:

- The lamp does not illuminate when the ignition switch is turned on.
- The lamp does not go out after it illuminates.
- The lamp illuminates during driving.

Once the electronic parking brake (EPB) fault warning lamp shows the above abnormalities, please contact the Service Center in time. An electronic parking brake fault can cause the vehicle to coast.

#### Note\*

**Parking Brake Telltale may blink in cluster after ignition off few times. This is normal phenomenon\*.**

### Automatic Vehicle Hold (AVH) Working Indicator\*



The automatic vehicle hold (AVH) working indicator illuminates after the ignition switch is turned on and it goes out several seconds later. This indicates that the indicator can work normally. For certain vehicle models, the indicator does not illuminate when the ignition switch is turned on.

This indicator illuminates when the automatic vehicle hold function works and the vehicle is being parked.

It goes out as the vehicle gets out of the parking state.

For details about automatic vehicle hold (AVH), please refer to “Parking Brake” under “Driving and Controls”.

### Automatic Vehicle Hold (AVH) Fault Warning Lamp\*



The automatic vehicle hold (AVH) fault warning lamp illuminates after the ignition switch is turned on and it goes out several seconds later. This indicates that both the warning lamp and the automatic vehicle hold function module can work normally. For certain vehicle models, the warning lamp does not illuminate when the ignition switch is turned on.

In case of an automatic vehicle hold function module fault or a warning lamp fault, it will be indicated in any of the following ways:

- The lamp does not illuminate when the ignition switch is turned on.

- The lamp does not go out after it illuminates.
- The lamp illuminates during driving.

Once the automatic vehicle hold (AVH) fault warning lamp shows the above abnormalities, please contact the MG Authorised Service Center in time.

**ESC Fault Warning Lamp**

The warning lamp illuminates after the ignition switch is turned on and it goes out several seconds later. This indicates that the warning lamp can work normally. The ESC lamp flashes once the ESC function is triggered off. The system informs the driver that ESC is working in this way. If the ESC lamp keeps illuminated, it indicates an ESC fault. Please refer to information given in “Electronic Stability Control (ESC)” under “Driving and Controls”.

**ESC OFF Indicator**

The warning lamp illuminates after the ignition switch is turned on and it goes out several seconds later. This indicates that the warning lamp can work normally. If you press “ESC OFF” switch when the vehicle speed has not exceeded the threshold value, certain functions of ESC will be deactivated. At this time, ESC OFF indicator illuminates. Please refer to information given in “Electronic Stability Control (ESC)” under “Driving and Controls”.

**Note**

**Generally, it is not advised to turn ESC OFF switch off.**

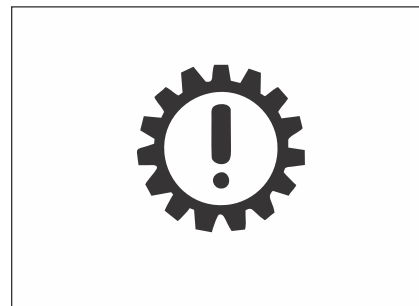
**Transmission Fault Warning Lamp\***

The transmission fault warning lamp illuminates when the ignition switch is turned on and it goes out several seconds later. This indicates that both the warning lamp bulb and the automatic transmission control system can work normally.

For certain vehicle models, the warning lamp does not illuminate when the ignition switch is turned on. It only illuminates upon fault occurrence.

In case of an automatic transmission system fault, the warning lamp will give out indication in any of the following ways:

- The lamp does not illuminate when the ignition switch is turned on.



**Emergency Parking (EP) Indicator\***

- The lamp does not go out after it illuminates.
- Flashing or keeping illuminated during driving.

In case of this, please contact the Service Center in time.



For vehicle models equipped with a dual clutch transmission (DTC), if the transmission is subject to a serious functional malfunction during driving, the instrument will send out an alarm sound.

In case of this, please stop the vehicle at the nearest safe place and contact the MG Authorised Service Center immediately. Please do not continue driving until the fault is removed.

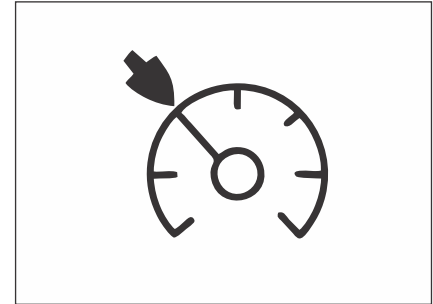
**Cruise Control System Working Condition Indicator\***

This indicator illuminates when the cruise control function is activated. Refer to information given in “Cruise Control System” under “Driving and Controls”.

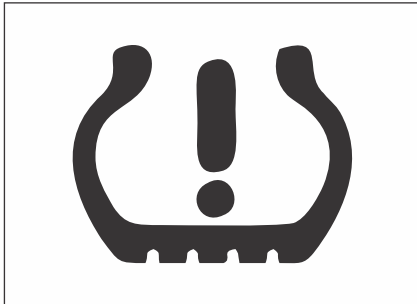
**TPMS Fault Indicator\***

The warning lamp illuminates after the ignition switch is turned on and it goes out several seconds later. This indicates that the warning lamp can work normally.

The TPMS fault indicator illuminates when the tyre pressure is too low or too high, or when a TPMS fault occurs.

For the correct tyre pressures, please refer to “Technical Data”.

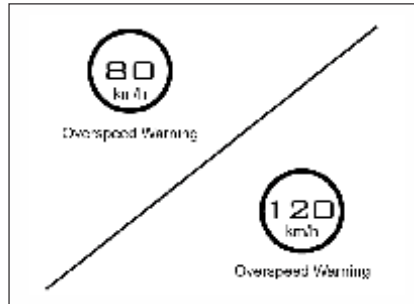
**Overspeed Warning**

If the vehicle speed is greater than 80km/h, the meter will make an audible alarm sounds and displays alarm icon. If the vehicle speed is always more than 80km/h then every two minutes, the alarm will indicate the overspeed driving. The "OK" button removes the icon from display.

Alarm will stop warning when the speed comes below 75km/h, then again over 80km/h, it will be warn for overspeed.

If the vehicle speed is more than 120km/h, the alarm will come continuously, and icon is always displayed. You can use the “OK” button to remove the icon.

Alarm will stop warning when the speed comes below 115km/h, then again over 120km/h, it will be warn for overspeed.

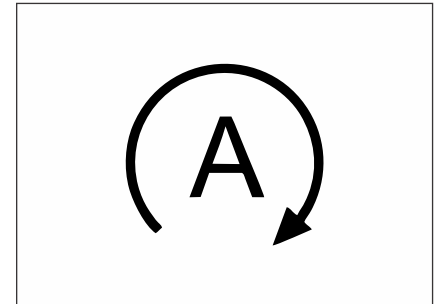
**Vehicle – Start / Stop Function**

This indicator illuminates when vehicle start / stop function is functioning. This function indicates Engine automatically start / stop.

### SCR (Selective Catalytic Reduction) Warning Light



The Low Diesel Exhaust Emissions Additive Diesel Exhaust Fluid (DEF) indicator light illuminates when the Diesel Exhaust Fluid (DEF) level is low.

Fill the Diesel Exhaust Fluid (DEF) tank as soon as possible with at least 5 liters of Diesel Exhaust Fluid (DEF).

### Diesel Particulate Filter Indicator

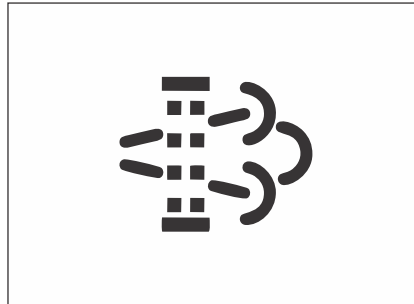

The indicator will illuminate when DPF is blocked completely / partially. It does not affect the operation of the vehicle, but if it is due to blockage of DPF, it may affect engine power performance. After this warning light is ON, please drive vehicle at a constant speed of 70-80km / h for a while. Release the throttle for a while, repeat the process. Do it 3 or 4 times. If the indicator is still running after running at high speed, please go to the service center for rectification.

### Fuel Water Indicator Light\*



This indicator will illuminate when the water is mixed with the fuel.

Once the light glows, immediately, drain the water through the bottom of the water separator / fuel filter. Release the water to drain, otherwise it will cause damage to oil injection Parts. If the indicator is still glowing please contact the MG Authorised Service Centre for rectification if necessary.

**Engine Hood Open Indicator\***



This indicator will illuminate when the engine hood is opened or it is not properly closed.

**Vehicle - Start / Stop Fault Indicator**

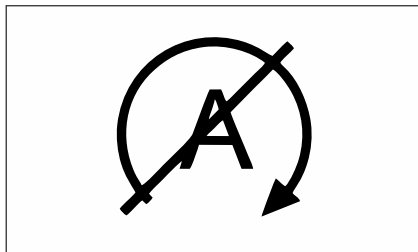

This indicator illuminates when vehicle start / stop function is not functioning.

**Glow Plug Indicator\***

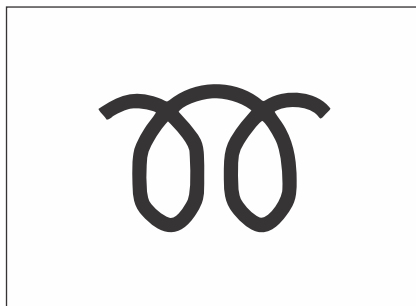

This indicator will illuminate when the glow plug is working on diesel.

This means that the engine is warming up. Do not start during this period, once the light is switched off then only start the engine. This will make the startup process very smooth.

**48v System Failure Warning Light\***

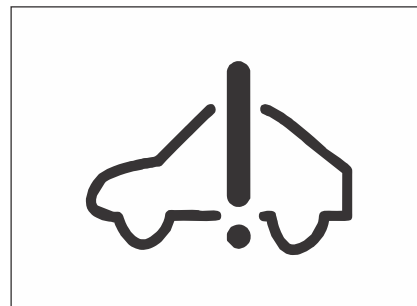

This indicator will illuminate when the 48V hybrid system not working.

Please contact the MG Authorised Service Centre as soon as possible.

## Reverse Sensor\*

The intelligent reverse sensor judges the distance between rear end of the vehicle and the obstacle via the ultrasonic transducer installed on the rear bumper.

If the buzzer buzzes once after you turn on the ignition switch and shift to reverse gear, it indicates that the system can work normally.

If the buzzer buzzes twice, it indicates that one transducer fails to work; if it buzzes thrice, it indicates that 2 or more transducers cannot work normally.

The intelligent reverse sensor starts to work immediately every time you turn on the ignition switch and shift to reverse gear.

When the distance between the vehicle and the obstacle behind it is within about 1.5 m~1.0 m, the reverse buzzer sends out alarm sound at long intervals.

When the distance between the vehicle and the obstacle behind it is within about 1.0 m~0.6 m, the reverse buzzer sends out alarm sound at short intervals.

When the distance between the vehicle and the obstacle behind it is within about 0.6 m~0.4 m, the reverse buzzer sends out alarm sound at shorter intervals.

When the distance between the vehicle and the obstacle behind it is within about 0.4 m, the reverse buzzer sends out alarm sound constantly.

### Note

- **Please note that the system is likely to work abnormally due to wrong induction under the following circumstances: reversing the vehicle on an uneven road, a road paved with round stones, an uphill road or grassland; interference from ultrasonic noise, metallic sound or high-pressure gas emission sound of the same frequency; sundries on the transducers; height change of vehicle rear end under heavy load; other detecting equipment installed within the effective detection range.**
- **If any nonstandard radio communication equipment is installed on the vehicle, usage of such equipment (not including mobile cellphone and audio system) may affect the function of this system.**

### Note

- **To ensure reversing safety and to leave enough time for the system to detect, please drive at a speed of 5 km/h or lower during reversing.**
- **Please stop the vehicle immediately a constant alarm sound is heard in case that the vehicle bumps onto the obstacle behind it.**
- **Please do not knock the transducers hard or wash them directly with a high-pressure water gun, otherwise the transducers can be damaged.**
- **Sundries on the transducers such as snow, mud and water drops can lead to misoperation.**
- **Please note that the system is likely to fail to detect the following obstacles: those of a conical shape or acute angle reflectors; objects which are prone to absorb sound wave, such as cotton and snow; fine objects such as iron gauze and ropes; objects 30 cm or lower to the ground or 1 m or higher than the ground. The system may detect these obstacles first, but as they become nearer and nearer to the vehicle, they can get out of the effective detection range, not detected as a result.**
- **When reversing down or up a slope, the system may give out a wrong warning, reminding you to take great care.**

### Reverse Video Display\*

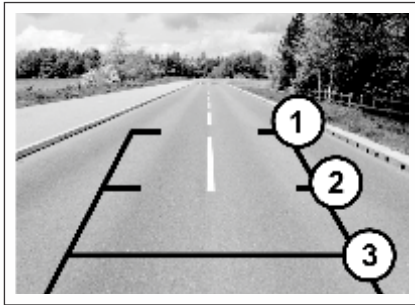

As is shown in the figure, if the vehicle is equipped with reverse camera, images behind the vehicle, reverse auxiliary lines and guide lines will appear on the multimedia player screen after you turn on the ignition switch, release the parking brake and shift to Reverse Gear "R". If the vehicle is of high configuration, a sector indication area will also show on the screen.

#### Reverse Auxiliary Line

The auxiliary is divided into three sections: red, yellow and green, based on the distance between the object and rear end of the vehicle.

The bottom red line represents the warning line for a distance from the obstacle to the vehicle rear end within 0.4 m; the middle yellow line represents the warning line for a distance from the obstacle to the vehicle rear end within 1.0 m; the top green line represents the warning line for a distance the obstacle to the vehicle rear end within 2.0 m; the line on both sides is the vehicle width indication line.

#### Reverse Guide Line\*

The yellow guide line can develop into a dynamic virtual guiding line as you turn the steering wheel.

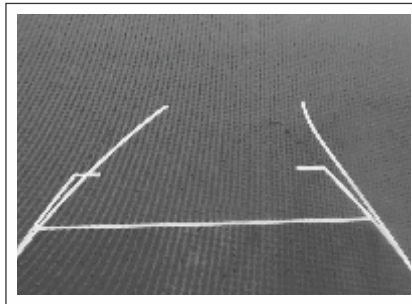

### Sector Indication Area\*



As is shown in the figure, a total of 6 sector indication areas are shown on the screen, indicating the distance from the obstacle to front left, front right, rear left, rear right, rear left middle and rear right middle of the vehicle respectively.

For the front left, front right, rear left and rear right sector indication areas:

When the distance from the vehicle to the obstacle is within about 0.4 m–0.6 m, the sector indication area appears yellow and the buzzer sends out alarm sound at short intervals. When the distance is within 0.4 m, the sector indication area appears red and the buzzer sends out alarm sound constantly.

For the rear left middle and rear right middle sector indication areas: When the distance from the vehicle to the obstacle is within about 0.6 m~1.0 m, the sector indication area appears green and the buzzer sends out alarm sound intermittently. When the distance is within 0.4 m~0.6 m, the sector indication area appears yellow and the buzzer sends out alarm sound at short intervals. When the distance is within 0.4 m, the sector indication area appears red and the buzzer sends out alarm sound constantly.

### Caution

**The intelligent reverse camera can only help the driver avoid accident during reversing. The driver should always keep concentrated. MG Motor shoulders no responsibility for any personal injury or vehicle damage resulting from careless driving with great reliance on the on-board reverse camera. Before reversing, please ensure that no child or animal is near the vehicle.**

### Parking Assist System\*

The parking assist system judges the distance between front/rear end of the vehicle and the obstacle via the ultrasonic transducer installed on the front/rear bumper. If the buzzer buzzes once after you turn on the ignition switch, it indicates that the system can work normally.

If the buzzer buzzes twice, it indicates that one transducer fails to work; if it buzzes thrice, it indicates that 2 or more transducers cannot work normally.

When a transducer fault is detected, the fault information will appear on the audio system display screen.

### Caution

**The reverse camera and the parking assist system can only help the driver avoid accident during reversing or parking. The driver should always keep concentrated. MG Motor shoulders no responsibility for any personal injury or vehicle damage resulting from careless driving with great reliance on the on-board radar system. Before reversing or parking, please ensure that no child or animal is near the vehicle as the radar system may fail to respond to them.**

### Parking Assist System Switch\*

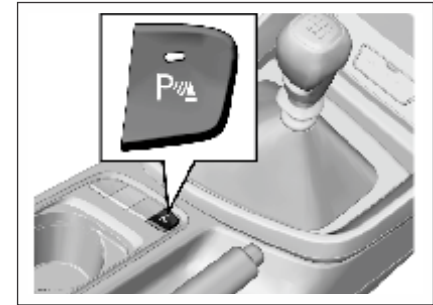

If the vehicle is equipped with parking assist system switch, the switch indicator will illuminate after the ignition switch is turned on and the parking assist system switch is pressed; if the parking brake is released at this time, the parking assist system starts to work.

If front/rear end of the vehicle is within certain distance from the obstacle, parking assist indication will appear on the audio system display screen. Press the switch again and the parking assist system turns off. The switch indicator also goes out.

The parking assist system activates automatically (under the precondition that the parking brake is released) as the shift lever is turned to the reverse gear.

It exits when the vehicle speed exceeds 20 km/h. To activate the system again, please press the switch.

### Parking System Display\*

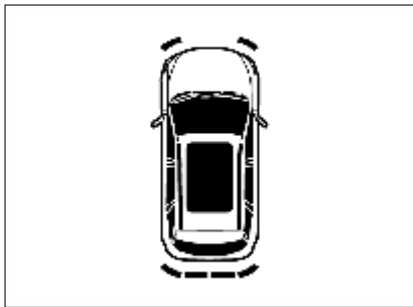

As is shown in the figure, when the transmission is engaged on the Forward Gear (D Mode) or the Neutral Gear, a prompt window will pop up in the audio system display screen as front end of the vehicle is within about 0.6 m from the obstacle or rear end of the vehicle is within about 1.5 m from the obstacle.

Color of the front and rear sector areas will change as the distance changes, accompanied by alarm sound. Please refer to information given in “Sector Indication Area”.

The prompt window will disappear when the system detects no obstacle.

The window will disappear immediately you press the window off button (x). It will appear again if an obstacle is detected.

### 360 Degree Panoramic Parking Screen Assist\*

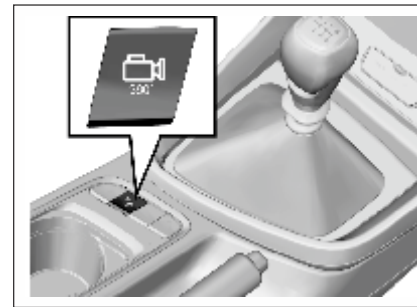

The 360° panoramic parking image assist is to display the images collected by the cameras installed on both sides of the outside rearview mirrors and the front/rear bumpers on the display screen of the audio system to help you check the outside environment. Turn the ignition switch at the ON position before using this function. It exits when the vehicle speed exceeds 20 km/h.

When the transmission is at Forward Gear (D Mode) or Neutral Gear, press the switch to display the 360° panoramic parking image assist. When the transmission is at R gear, this function is enabled automatically.



### Panoramic Parking Screen Switch

When the transmission is engaged in Forward Gear (D Mode) or Neutral Gear, press ON / Off switch to display 360 degree parking screen auxiliary function.

It is automatically turned on when the Reverse Gear (R) is engaged. Under the parking assist screen, according to your needs, Tap the screen selection icon on the left side of the center console to cut change to the corresponding interface below. Using left / right indicators can also change interface view.

### Parking Image Assist during Reversing



When the transmission is turned to R gear, the "rear view + side view + 3D panoramic view" will appear on the display screen of the audio system to help you check the environment behind the vehicle when reversing.

### Parking Image Assist at Forward Gear (D Mode) or Neutral Gear

When the transmission is at Neutral Gear or Forward Gear (D Mode), if you want to check the environment in front of the vehicle, press the panoramic parking image switch to display the "front view + side view + 3D panoramic view".

If you need to check the side environment during turning, press the switch first and then turn on the turn signal lamp to display the "front/rear view + side view + 3D panoramic view" on the display screen of the audio system.

You can also press the keys on the screen to switch the images.

#### Warning

**There is a certain blind spot in the parking screen, especially near the area around the vehicle. Therefore, it must be cautious, not to use this function as the only basis for judging safety.**

**MG India is not responsible for any inadvertent driving if assisted by the parking screen of the device cause personal injury and property damage.**



# Lighting

## Outside Lighting..... 104

- Lighting Switches..... 104
- High Beam ..... 104
- Automatic Headlamp ON/OFF ..... 104
- Headlamp Flashing ..... 104
- Automatic Wiping ..... 105
- Hazard Flasher ..... 105
- Turn and Lane Change Signal Lamp..... 105

## Fog Lamp..... 106

- Steering Assist Lighting Function\* ..... 106
- Front Fog Lamp\* ..... 106
- Rear Fog Lamp..... 107

- Stop Lamp..... 107

- Day Running Lamp\* ..... 107

- Headlamp Leveling..... 107

- Headlamp OFF Delay..... 107

- Lamp ON Reminder..... 107

## Inside Lighting ..... 108

- Front Reading Lamp ..... 108

- Rear Reading Lamp ..... 108

- Luggage Compartment  
Illumination Lamp ..... 109

## Outside Lighting

### Lighting Switches



To switch ON or OFF the headlamp, tail lamp and parking lamp, please turn the end of the combination switch control lever.

The lighting switch has 3 positions and they represent different lighting functions:

OFF= All the lamps are turned off.

AUTO= Automatic Light Control turns the lights on whenever the sensor, in the instrument panel, senses dark conditions. The system will activate the lights when the car is driven in a enclosure, such as a parking garage. Heavy overcast conditions can cause the lights to switch on.

☾☼ = The position lamp, license plate lamp,

instrument panel lamp and backlight of all the panels illuminate.

☾☼ = The low beam lamp and all lamps mentioned above illuminate under the precondition that the ignition switch is turned to ON position.

### High Beam

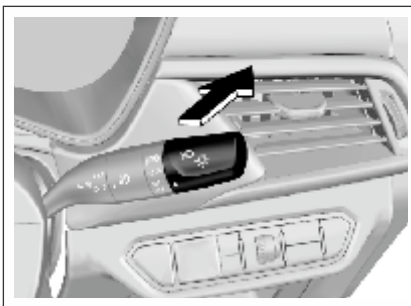

To turn on headlamp high beam:

- Ensure that the ignition switch is in ON position;
- The headlamp is in a low beam state;
- As is shown in the figure, push the combination switch control lever towards the instrument panel.

The headlamp high beam indicator illuminates when the headlamp high beam is turned on. To switch from headlamp high beam to low beam, pull the control lever towards the opposite direction until it returns to the normal position.

### Automatic Headlamp ON / OFF

When the ignition switch is in ON position, turn the combination switch lever to AUTO Position. This activates automatic headlamp ON / OFF function.

The system's light sensor recognizes the environment's light and dark condition.

### Headlamp Flashing

To activate headlamp high beam flashing, please pull the combination switch control lever toward yourself and then release it. The control lever will return to the normal position as you release it.

Before you release the control lever, the headlamp high beam keeps illuminated.

### Warnings

**While approaching incoming vehicle or the vehicle ahead, please use low beam. This is because headlamp high beam can make other driver feel temporarily blind and cause collision as a result.**

### Automatic Wiping

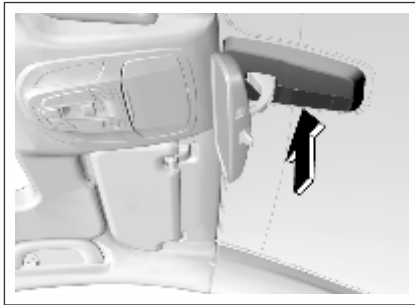

The sensor is installed on the front windshield. Light and rain sensors are used to sense light and rain. The control module provides sensing signals for bad / good lighting & amount of water vapor / rainfall on the surface of the glass.

The automatic control (AUTO) function of the wiper / headlamp acts accordingly.

Stains or snow and ice can affect the sensor's performance. Please clean up the glass on time.

### Hazard Flasher

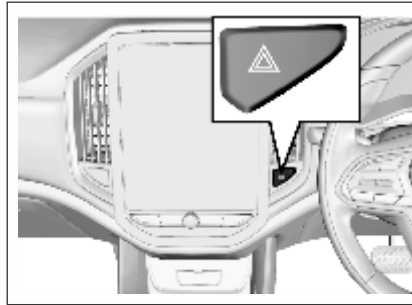

Press  to turn on/off the hazard flasher.

#### Note

**Please turn on the lights manually in a dense fog environment. The lighting system may not automatically turn ON because of dense fog. Automatic lighting control is just an auxiliary function. The driver should use lights as per the requirement of environment.**

### Turn and Lane Change Signal Lamp

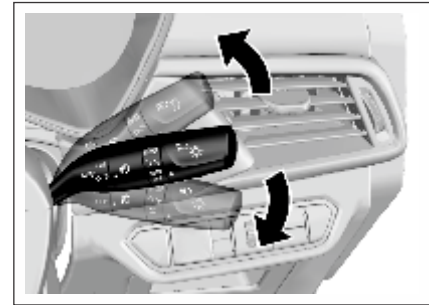

To turn on the Turn And Lane Change Signal Lamp, the ignition switch must be in ON position.

Control lever upward = right turn signal lamp

Control lever downward = left turn signal lamp

After cornering, the turn signal interrupts automatically and the control lever returns to the normal position.

To change the lane, you can pull the control lever to halfway position (not reaching the turn signal lamp position) and keep pulling it. After lane change, release the control lever and it will return to the normal position automatically.

A rear turn signal lamp is integrated on the rear combination lamp and the rear bumper of your vehicle respectively. If you turn on the turn signal lamp with the liftgate open, the turn signal lamp on the rear bumper will illuminate. This ensures that a turn signal is sent to the drivers behind even when the liftgate is open.

## Fog Lamp

### Steering Assist Lighting Function\*

During steering, the two front fog lamp will illuminate to provide auxiliary lighting if certain conditions are satisfied. These conditions are:

1. The engine is running;
2. The vehicle speed is  $\leq 35$  Km/h;
3. The low beam lamp is turned on;
4. The steering wheel angle is  $>60^\circ$  or the turn signal lamp switch is turned on.

As the front fog lamp illuminates, the front fog lamp indicator on the instrument panel also illuminates.

The steering assist lighting function deactivates and the front fog lamps go out after a while under any of the following condition:

1. The steering wheel angle is  $\leq 30^\circ$  or the turn signal lamp switch is turned off.
2. The ignition switch is turned to a position other than ON.
3. The vehicle speed is  $> 40$  Km/h;
4. The low beam lamp is turned off.

### Front Fog Lamp\*

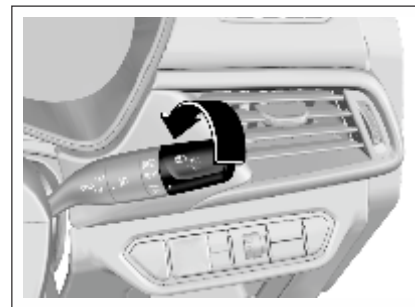

When the ignition switch is turned to ON position, and the headlamp functions as a position lamp or in a low beam state, turn the ring button in the middle of the combination switch to ON (connected) position to turn on the front fog lamp. Turn the ring switch to OFF (disconnected) position to turn off the front fog lamp.

### Rear Fog Lamp



When the headlamp is in low beam state or the front fog lamp is turned on, turn the rear wiper control knob to “s” position and then release it to turn on the rear fog lamp. Turn the knob again to turn off the rear fog lamp.

If the low beam lamp or front fog lamp is turned off with the rear fog lamp turned on, the rear fog lamp keeps on.

### Backup Lamp

The backup lamp illuminates after you turn on the ignition switch and shift to reverse gear.

### Stop Lamp

The stop lamp illuminates as you depress the brake pedal.

### Day Running Lamp\*

The day running lamp turns on automatically as the engine starts; it goes out automatically as the position lamp is turned on.

### Headlamp Leveling

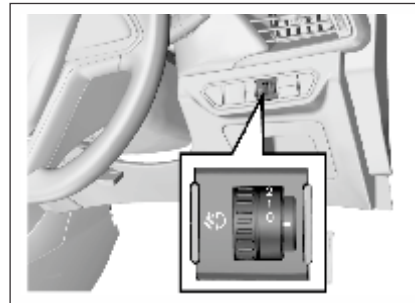

The headlamp leveling knob is located at the left side of the instrument panel.

Please adapt the headlamp illuminate range to the vehicle load so as to acquire the best lighting effect and avoid dazzling. Turn the knob to the desired position:

0 = front seats occupied

1 = all seats occupied

2 = all seats occupied with the luggage compartment loaded

3 = driver's seat occupied with the luggage compartment loaded

### Headlamp OFF Delay

To trigger off headlamp OFF delay function, turn off the headlamp and pull the light control lever towards the steering wheel within one second for twice after you shut down the engine and turn the ignition switch to ACC or LOCK position, or after you pull out the key. After remote locking, the low beam lamp will turn off automatically 30s later; if the vehicle is not remotely locked, the low beam lamp will turn off automatically 10 minutes later.

### Lamp ON Reminder

If any lamp switch is not turned to OFF position after you turn the ignition switch to LOCK position or pull out the key, the buzzer will send out alarm sound as the driver's door is opened. The alarm sound stops after the lamp is turned off.

## Inside Lighting

### Front Reading Lamp Type-I

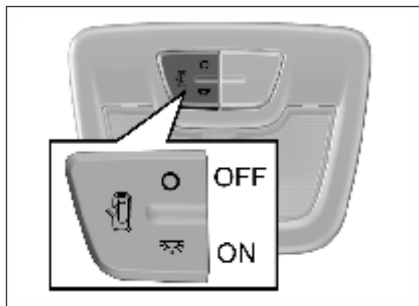

The lamp has 3 working positions.



 : The lamp illuminates and keeps illuminated until it is manually turned off.

 : The lamp gradually illuminates as any door is opened; it works for a while and then gradually goes out after all the doors (including liftgate) are closed.

 : The lamp does not illuminate even a door is opened.

### Type-II



 or  : Press the button to turn on the left/right reading lamp and press it again to turn the lamp off.

 : The reading lamp gradually illuminates if any door is opened (including liftgate) as the button is pressed. It gradually goes out after all the doors are closed.

### Warnings

**Please avoid usage of the inside lamps during driving in darkness. A bright passenger compartment can reduce the visibility outside and cause collision as a result.**

### Rear Reading Lamp Type-I



The rear reading lamp has 2 working buttons:

 : Press the switch and the lamp illuminates. It will not go out until the switch is pressed again.

 : The lamp gradually illuminates if the switch is pressed and any door is opened; it works for a while and then gradually goes out after all the doors (including liftgate) are closed.



## Type-II

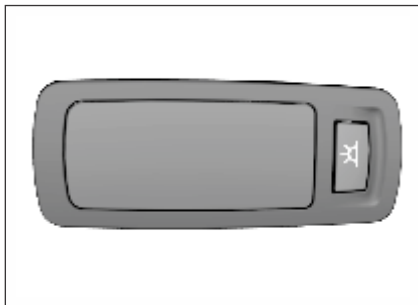

For certain models, two reading lamps are installed on the roof over the second row seats. You can press the reading lamp switch to turn it on/off.

## Luggage Compartment Illumination Lamp

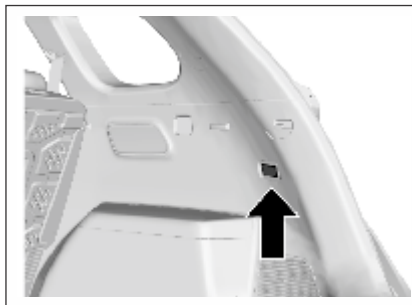

The luggage compartment illumination lamp illuminates as the liftgate is opened. It goes out after the liftgate is closed.

### Note

**Please do not replace with a high-power bulb (for example, refit with a xenon headlamp) in case that the lamp burns out or an accident arises from it.**

**Please turn off all lamps before you leave the vehicle.**



# Audio Entertainment System

<b>Audio Control Buttons on Steering Wheel*</b> .....	<b>112</b>
<b>Driver Information and Entertainment</b> .....	<b>113</b>
• Navigator Upgrading* .....	114

## Audio Control Buttons on Steering Wheel\*

### Type I

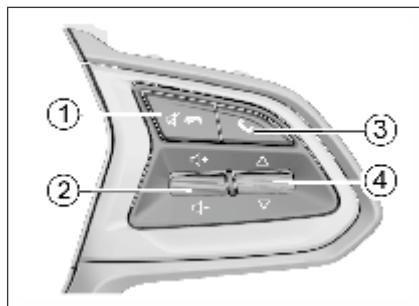

#### 1. Mute or Call Hangup Button

It is used to sound off or hang up a Bluetooth telephone call.

#### 2. Volume Adjustment Thumbwheel

Pull the thumbwheel up and down to adjust the sound volume.

#### 3. Bluetooth Setup or Call Answer Button

Press the button to enter the Bluetooth interface or answer the Bluetooth telephone call.

#### 4. Song Selection / Station Switch Thumbwheel

Pull the thumbwheel up and down to select the station or song.

### Type II

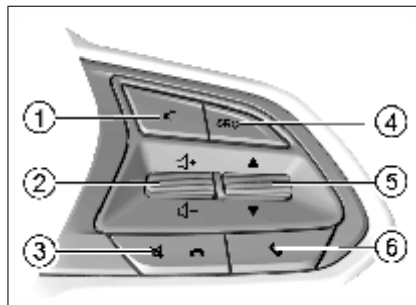

#### 1. Reserved Button

It is reserved with no role to play for the time being.

#### 2. Volume Adjustment Thumbwheel

Pull the thumbwheel up / down to increase / decrease the volume.

#### 3. Mute or Call Hangup Button

It is used to sound off or hang up a Bluetooth telephone call.

#### 4. Audio Source Selection Button

Press the button to switch among audio sources such as radio / USB / Bluetooth music.

#### 5. Song Selection / Station Switch Thumbwheel

Pull the thumbwheel up / down to select the next / previous station or song.

#### 6. Call Answer Button

Press the button to answer Bluetooth phone calls or enter the Bluetooth interface.

## Driver Information and Entertainment

As the model configuration or the supporting manufacturers are different, the audio entertainment system function, the display interface and the operation method may be different, such as video and entertainment, navigation, reverse camera, Bluetooth and telephone calls. For details about functional introduction and description of the audio entertainment system, please refer to the *Vehicle Audio System Instructions* placed in the glove box.

### Inspection before Repair

If you feel a bit of misgiving about certain audio function, before driving the vehicle to the Service Center for repair, please first read the directions given in the product instructions carefully and then check and operate according to the following table. This can help you remove the fault.

The host does not work and no information is shown on the screen.	Take out the host from the instrument panel, and then check the host fuse and connector to the vehicle.
The host works but no sound can be heard or the sound volume is very low.	Increase the sound volume and check the front/rear and left/right balance setup of the horn.
The device body is a little hot.	The device heats normally as it works.
The radio cannot search for the desired station.	Inspect whether the antenna is fully stretched and connected correctly. Inspect whether the antenna amplifier in the vehicle has been damaged. Signal of the desired station is too weak and please tune manually.
Certain audio files cannot be played via USB connection.	Please confirm whether the device supports such audio files. Refer to the vehicle audio system instructions.
The sound volume fluctuates as MP3 songs are played.	As MP3 songs are of wide sources and no uniform standard applies. The reason can be that the volumes of MP3 songs are different as they are compressed. Please turn the volume knob to adjust in case of this.
The singer/track/song name cannot be displayed.	The device does not support text display of the audio file.
The music pauses intermittently as it is played.	The reason can be that the format of the music file is different as it is compressed.
Songs stored in the memory device cannot be read.	Please confirm that the storage partition form of the memorizer is FAT16 or FAT32 as it is checked in the computer; if not, please make new setup on the computer to change the format into a standard applicable to the device requirement.
MP3 songs cannot be read via an all-in-one USB adapter.	This device only supports song reading via an adapter with only one USB port.
Noise can be heard.	The noise can be produced by the device used to record the original audio file or it may be the noise existed at the time of recording. Please use other players to play the file and then confirm whether the problem lies in this device.
If the fault still cannot be removed, please go to the MG Authorised Service Center for inspection. Never disassemble the host to repair it on yourself.	

### **Navigator Upgrading\***

When the navigator cannot display comparatively new main roads, it is time to update and upgrade the map data.

For details, please refer to the navigation system instructions.

#### **Note**

**After upgrading, the map may still fail to display all the roads which are recently completed and open to traffic. It is normal that certain roads can be displayed only on an upgraded map of a followup version.**

## HVAC

- Air Outlet ..... 116**
- Air Conditioning ..... 118**
  - Electronic Air Conditioning Control Panel ..... 118
  - Temperature Control Key ..... 119
  - Fan Control Key ..... 119
  - Air Distribution Mode ..... 119
  - Front Windshield Defrosting Key ..... 121
  - Internal / External Circulation Mode Key ..... 121
- Manual Air Conditioning ..... 122**
  - Control Panel..... 122
  - Temperature Control Knob ..... 123
  - Fan Control Knob ..... 123
  - Air Distribution Mode Button ..... 123
  - Internal Circulation Mode Button..... 123
  - Rear Windshield Defroster Button\* 124
  - Air Conditioning (A/C) Button..... 124
  - Cool Air ..... 125
  - Warm Air ..... 125
  - Ventilation..... 126
  - Rapid Defrosting and Defogging..... 126

## Air Outlet

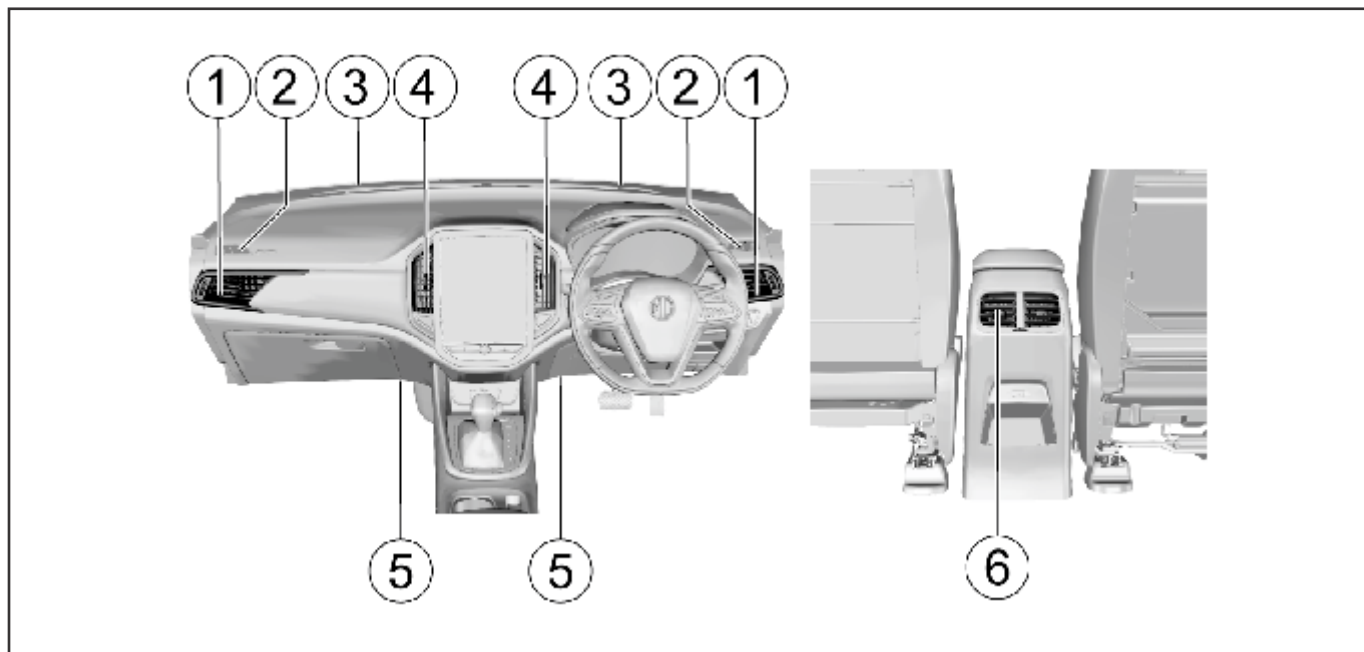

1. Side Air Outlet

2. Front Door Window Defogger Air Outlet

3. Front Windshield Defogger Air Outlet

4. Central Air Outlet

5. Floor Air Outlet

6. Console Air Outlet



### Side Air Outlet

You can divert the air to both sides of the front riding area or the side door windows by operating the two adjustable side air outlets. Beside each air outlet, an air volume adjustment switch is located and you can operate the switch to adjust the air volume.

### Front Door Window Defogger Air Outlet

The front door window defogger air outlet is used to divert the air to the side door window, mainly to the outside rearview mirror area.

### Central Air Outlet

You can decide the flow direction of the air from the two adjustable central air outlets.

### Front Windshield Defogger Air Outlet

The front windshield defogger air outlet is used to divert air to the front windshield.

### Floor Air Outlet

The floor air outlet is used to divert the air to the front foot area.

### Console Air Outlet

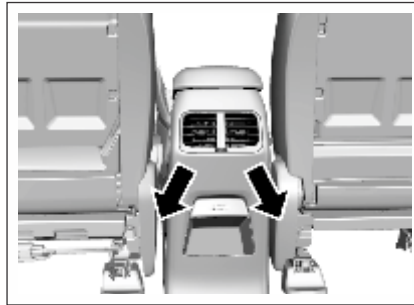

If equipped, the air outlets are located on the back of the armrest between the two front seats. They can divert the air to the rear passenger area.

### Rear Air Outlet\*



There is two rear air outlet for the 7 seater variant. You can decide the flow direction from the adjustable air outlet.

## Air Conditioning

### Electronic Air Conditioning Control Panel

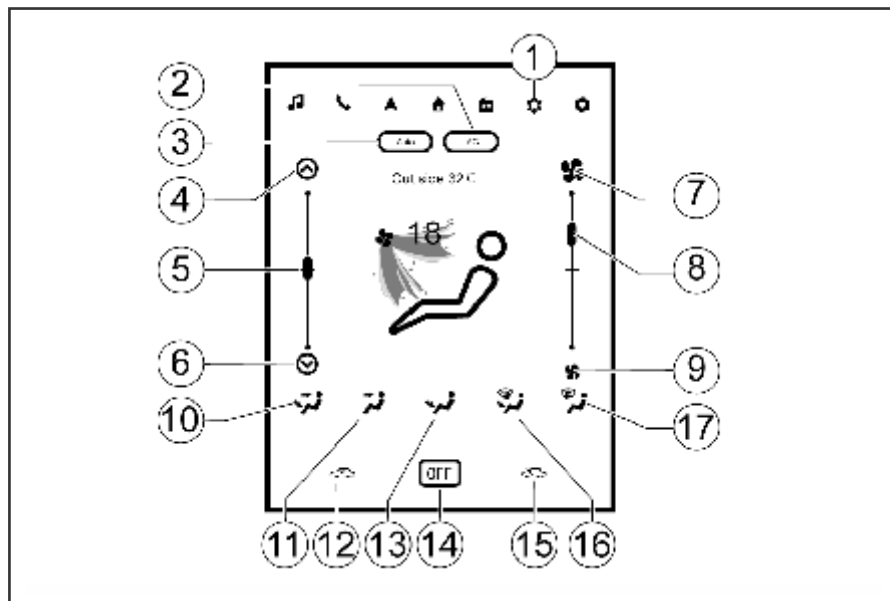

1. A/C Interface
2. A/C Key
3. Auto Key
4. Temperature Rise Key
5. Temperature Adjustment Slider
6. Temperature Drop Key
7. Air Volume Increase Key
8. Air Volume Adjustment Slider
9. Air Volume Decrease Key
10. Face-Foot Mode Key
11. Face Mode Key
12. Internal Circulation Mode Key
13. Foot Mode Key
14. OFF Key
15. External Circulation Mode Key
16. Foot/Defrosting Mode Key
17. Front Defrosting Mode Key

### Temperature Control Key

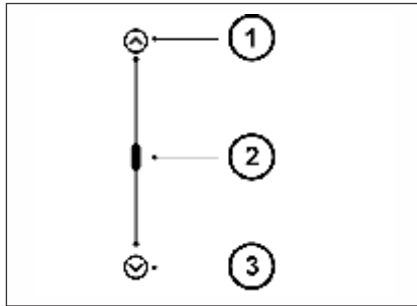

The temperature control key is used to control the air temperature at the vent. The temperature can be controlled by slider and increase/decrease key.

In A/C state, click the  $\wedge$  key once. The set temperature display increases 1 gear, with the maximum of Gear 8. Click the  $\vee$  key once. The set temperature display decreases 1 gear, with the minimum of Gear 1.

In AUTO state, click the  $\wedge$  key once. The set temperature display increases  $0.5^{\circ}$ , with the maximum of  $32^{\circ}$ . Click the  $\vee$  key once. The set temperature display decreases  $0.5^{\circ}$ , with the minimum of  $18^{\circ}$ .

You can also adjust the A/C temperature via temperature slider.

Once the temperature reaches the hottest (coolest) extent, if you pull the switch up again, the temperature stays unchanged.

### Fan Control Key

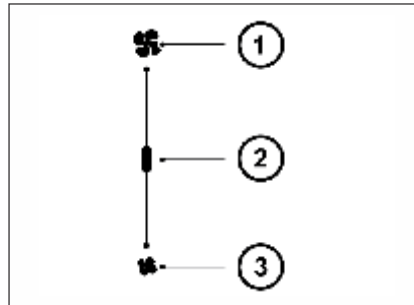

You can control the air volume at the air outlet via fan control key. The air volume can be controlled by slider and increase/decrease key. Click the  $\wedge$  key once. The air volume display increases 1 gear, with the maximum of Gear 8. Click the  $\vee$  key once. The air volume display decreases 1 gear, with the minimum of Gear 1.

### Air Distribution Mode

One of the following five positions can be selected in the air distribution mode according to the required airflow direction.

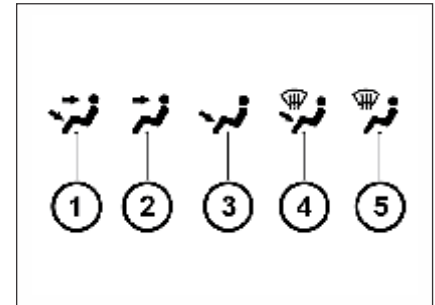

1. Face-foot mode key
2. Face mode key
3. Foot mode key
4. Foot/Defrosting mode key
5. Front defrosting mode key

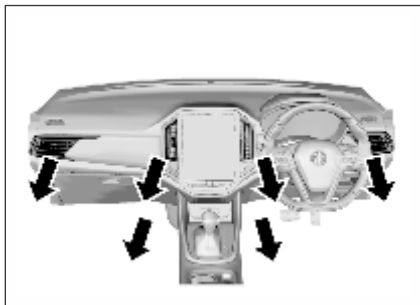
**Face-foot Mode (↻)**

In this mode, the air flows in two directions. Half of the air flows out from the floor air outlet and the front seat lower air outlet; the remaining air flows out from the central air outlet, side air outlet and console air outlet\*.

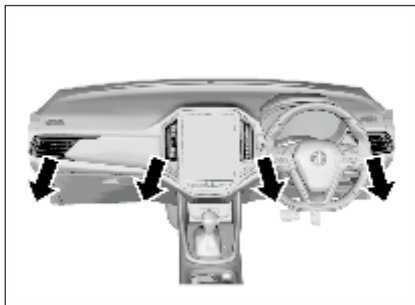
**Face Mode (↻)**

In this mode, the air flows out from the central air outlet, the side air outlet and the console air outlet\*.

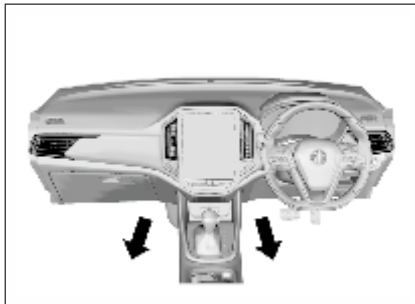
**Foot Blowing Mode (↻)**

Most of the air flows out from the floor air outlet and the front seat lower air outlet; little amount of air flows out from the windshield and front door window defroster air outlet and the side air outlet.

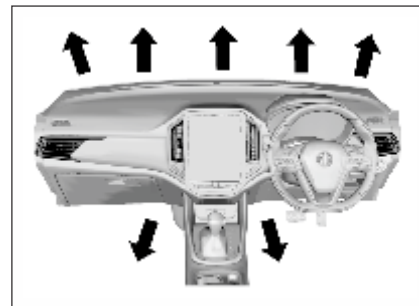
**Foot / Defrosting Mode (↻)**

In this mode, air flows out from the front windshield defroster air outlet, the front door window defroster air outlet, the floor air outlet, the front seat lower air outlet and the side air outlet.

### Front Windshield Defrosting Key

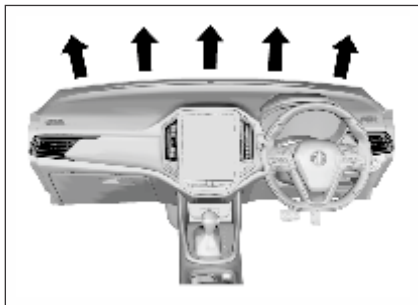

Press the button to select the front windshield defroster mode.

Press the front windshield defroster button and the air volume ascends to Range 6 automatically. If the air volume is already higher than 6 before the button is pressed, it will remain at same speed.

As you switch from the air blow mode to the defroster mode, the indicator below the button illuminates. As you turn on A/C function, the indicator on the A/C button illuminates.

The air circulation mode switches to external circulation. Press the button again to turn off the front defroster mode and the system restore to the state before defrosting.

### Internal / External Circulation Mode Key

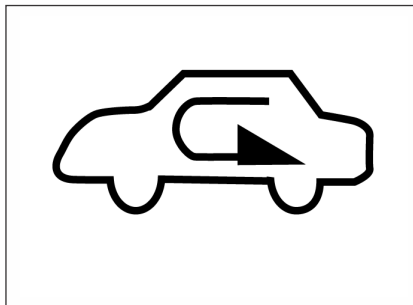

You can press this button during driving on a dusty road, or when you want to prevent the exhaust or outside smoke entering inside, or when you want to quickly decrease or increase temperature in the passenger area. The internal circulation icon displays in white, and the interior air is circulated internally.

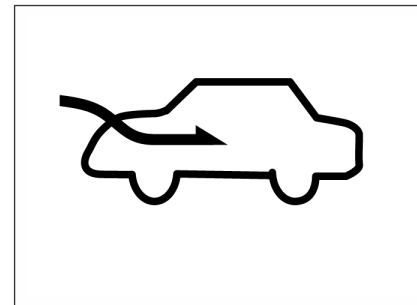

Press this key to switch to the external circulation mode. The external circulation icon displays in white, and the internal circulation icon displays in grey. The air is circulated externally.

The system memorizes the previously set air circulation mode the next time you start the vehicle.

#### Caution

**You may feel tired and sleepy after long-time driving in the internal circulation mode.**

**Please switch to external circulation mode on a regular basis to acquire fresh air.**

## Manual Air Conditioning Control Panel

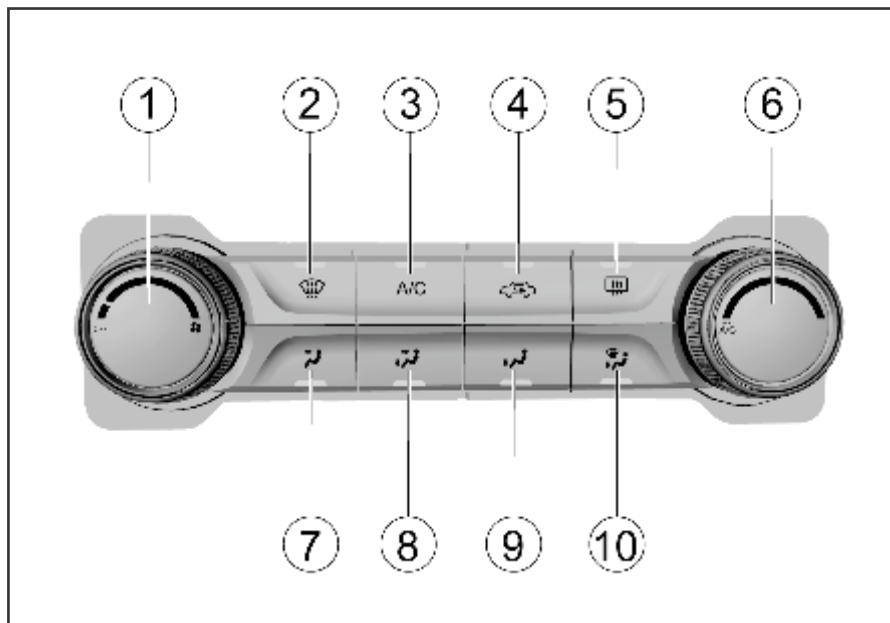

1. Fan Control Knob
2. Front Windshield Defroster Button
3. Air Conditioning (A/C) Button
4. Internal Circulation Button
5. Rear Windshield Defroster Button / Outside Rearview Mirror Defroster Button\*
6. Temperature Control Knob
7. Face Blowing Mode
8. Face/foot Mode
9. Foot Blowing Mode
10. Foot Blowing/Front Defrosting Mode

Note: Once the indicator of the button illuminates, the corresponding function starts to work.

### Temperature Control Knob



It is used to control temperature of the air flowing out from the air outlet.

Turn the knob to the blue area and cool air comes out; to the red area and warm air comes out.

### Fan Control Knob

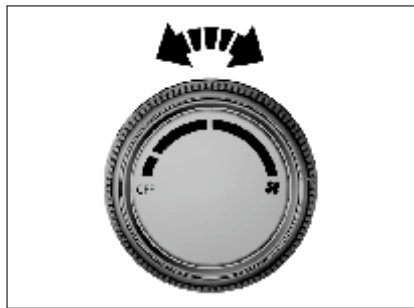

Turn the fan speed control knob to control the system air flow.

There are 8 wind speed gears in total, with the maximum of Gear 8. Turn it to "OFF" to close the air volume of the A/C system.

### Air Distribution Mode Button

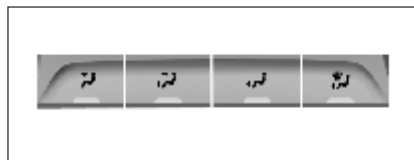

Adjust the air distribution knob to the desired mode so that the air flows in the desired

direction. Control the air to blow out from the corresponding air outlet. Please refer to the contents of "Air Distribution Mode" of the above automatic constant temperature A/C.

### Internal Circulation Mode Button

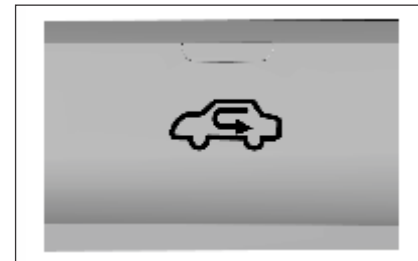

You can press this button during driving on a dusty road, or when you want to prevent the exhaust or outside smoke entering inside, or when you want to quickly decrease or increase temperature in the passenger area.

The indicator on the button illuminates and air starts to circulate inside the vehicle.

Press this button again to switch to the external circulation mode, the indicator will go out and outside fresh air enters inside.

**Caution**

You may feel tired and sleepy after long-time driving in the internal circulation mode, so please switch to the external mode on a regular basis to acquire fresh air.

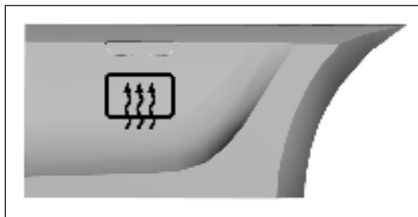
**Rear Windshield Defroster Button\***

To turn on the rear windshield defroster, first turn on the ignition switch and then press the rear windshield defroster button. The instrument on the button will illuminate. Please turn off the defroster after your view becomes clear.

**Caution**

**Usage of the rear windshield defroster is prohibited under the following circumstances:**

- The engine is not running.
- Snow or ice has deposited on the rear windshield.

If you use the rear windshield defroster under these circumstances, the vehicle battery can become under voltage.

Lack of proper maintenance may cause damage to the defroster or scratches on the glass.

It is not allowed to use any sharp cleaner or that prone to cause glass wear to clean the rear windshield.

During vehicle cleaning or when operating near the rear windshield, please take care not to shake or damage the defroster wire.

If the driver's view is affected, an accident can happen, causing personal injuries, damage to the vehicle or property loss.

**Air Conditioning System**

Refrigerating device of the air conditioning system is used to cool down the inside air and remove the moisture and dust contained in the air.

If the temperature control knob is already set to a comparatively high temperature, warm air will be generated inside the vehicle even though the air conditioning refrigeration (A/C) function is activated.

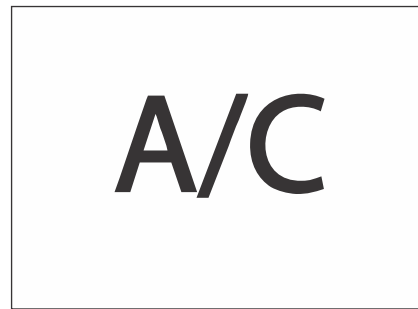
**Air Conditioning (A/C) Button**

To turn on the air conditioning (A/C) system:

1. Start the engine.
2. Press the air conditioning (A/C) button. The button indicator illuminates, indicating that the air conditioning system is working.
3. Adjust the fan speed.

To turn off the air conditioning system:

Press the A/C button again to make sure that the A/C stops refrigerating.

If the air conditioning system was kept on when the engine was shut down the last time, the system will turn on automatically as the vehicle is started next time.



**Note**

After the air conditioning system is turned on, you can find water drops in the lower area of the engine compartment. The water drops are formed as moisture in the air condenses on surface of the air conditioning system component, which is a normal phenomenon.

**Note**

As the air conditioning compressor works, it consumes certain engine power. This is the reason why you may find that the vehicle power performance decreases when the air conditioning refrigeration function is activated.

**Note**



The air conditioning system cannot work if the fan control thumbwheel is turned to OFF position.

**Cool Air****Fast Cooling**

To cool down fast in scorching hot days or after the vehicle is kept under the blazing sun for a long time:

1. Open the door windows a little to expel the hot air inside.
2. Turn on the air conditioning (A/C) system. (The indicator illuminates at this time.)
3. Activate the internal circulation mode.
4. Switch the air distribution mode to face mode (  ).
5. Adjust the temperature to the maximum coolness.
6. Adjust the fan speed to the maximum.

**Normal Cooling**

1. Turn on the air conditioning (A/C) button. (The indicator illuminates at this time.)
2. Activate the internal circulation mode.
3. Switch the air distribution mode to face mode (  ) or dual mode (  ).
4. Adjust the temperature to the cool air area.
5. Adjust the fan speed to the desired value.



**Warm Air****Rapid Heating**

Activate the rapid heating mode to increase the passenger area temperature quickly. It is prohibited to activate this mode for a long time, otherwise the inside air quality will decrease and fog can form on the windows. To clear up the fog on the windows, turn off the internal circulation mode so that fresh air enters inside.

To acquire the warmest air:

1. Turn off the air conditioning (A/C) system. (The indicator goes out at this time.)
2. Activate the internal circulation mode.
3. Switch the air distribution mode to foot mode (  ).
4. Adjust the temperature to the maximum warmth.
5. Adjust the fan speed to the maximum.

**Normal Heating**

1. Turn off the air conditioning (A/C) system. (The indicator goes out at this time.)
2. Activate the external circulation.
3. Switch the air distribution mode to foot mode (  ) or dual mode (  ).
4. Adjust the temperature to the warm air area.
5. Adjust the fan speed to the desired value.

## Ventilation

### Dual Mode

This mode is applicable to cool and sunny days. Warm air is controlled to flow to the floor area and outside cool air is controlled to flow to upper portion of the compartment.

The method to use this setup is:

1. Disable the internal circulation key. (The indicator goes out at this time.)
2. Switch the air distribution mode to dual mode (☼).
3. Adjust the temperature to the desired value.
4. Adjust the fan speed to the desired value.

### Ventilation

To control the air to flow out from the central air outlet and the side air outlet:

1. Turn off the air conditioning (A/C) system. (The indicator goes out at this time.)
2. Activate the external circulation mode.
3. Switch the air distribution mode to face mode (☼) or dual mode (☼).
4. Adjust the temperature to the cool air area.
5. Adjust the fan speed to the desired value.

## Rapid Defrosting and Defogging

**Please operate in the following steps in cold weather:**

- Air conditioning switch (A/C): ON (southern area) or OFF (northern area)
- Air inlet mode: external circulation mode (the indicator turns off)
- Air distribution mode: (☼)
- Temperature switch: red zone (warm air)
- Air volume switch: to the maximum
- Turn the air distribution knob to the foot / defrosting (☼) position to keep the front windshield clean and divert the warm air to the floor.

**Please operate in the following steps if not in cold weather:**

- Air conditioning switch (A/C): ON
- Air inlet mode: internal circulation mode (the indicator turns on) (☼). Switch it to the external circulation mode (the indicator turns off) after the fog lifts.
- Air distribution mode: (☼) or (☼).
- Temperature switch: to the area that ensures passenger comfort.
- Air volume switch: to the maximum

### Note

**At the beginning of defrosting and defogging with the warm air, the fog can become thicker, please take care to ensure driving safety.**

## Rear Fan Control Switch\*

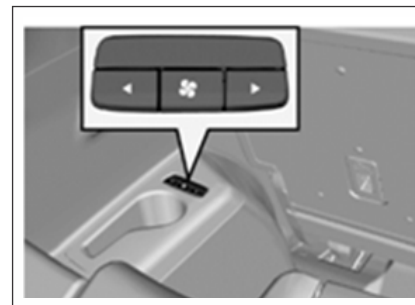

The switch located at the left rear cup holder for the 7 seater variant. Press the air conditioner switch to turn on/off the A/C. You can press the arrow button to raise or lower the air volume for the rear air outlet.

## Driving and Controls

<b>Driving Instructions</b> .....	<b>128</b>		
• Vehicle Control .....	128		
• Emergency Measures.....	128		
<b>Start and Operation</b> .....	<b>129</b>		
• Trial Run of New Vehicle.....	129		
• Mechanical Ignition Switch Position* .....	130		
• Engine START STOP Switch Position* .....	131		
• Electronic Steering Column Lock* .....	132		
• Engine Starting .....	133		
• Engine START STOP Function* .....	134		
• Cruise Control System *.....	135		
• Engine Immobilizer System .....	136		
• Parking.....	137		
<b>Manual Transmission*</b> .....	<b>137</b>		
• Operation for Shifting Transmission with Six Drive Gears to Reverse (R) Gear .....	138		
<b>Automatic Dual Clutch Transmission (DTC) *</b> .....	<b>138</b>		
		• Shifting .....	139
		• Gear .....	139
		• Gear Display.....	140
		• Vehicle Start.....	141
		• Automatic Upshift.....	141
		• Kick-down .....	141
		• Hill-start Hold Control.....	141
		• Run Downhill .....	142
		• Protection Mode.....	142
		• 48V Hybrid Power System*.....	143
		• Situations of Auto Engine Start.....	144
		• Continuously Variable	
		• Transmission (CVT) .....	147
		<b>Brake</b> .....	<b>147</b>
		• Anti-lock Brake System (ABS) .....	148
		• Electric Brake Force Distribution (EBD) System .....	148
		• Electronic Stability Control (ESC) System .....	148
		• ESC OFF Switch .....	150
		• Hill-start Hold Control (HHC) System* .....	150
		<b>Parking Brake</b> .....	<b>151</b>
		• Mechanical Hand Brake* .....	151
		• Electronic Parking Brake (EPB) * .....	152
		• Automatic Vehicle Hold (AVH) * .....	154
		<b>Fuel</b> .....	<b>155</b>
		• Fuel Suggestions .....	155
		• Fuel Filling .....	156

## Driving Instructions

### Vehicle Control

Do not slide in case that the engine is out of operation.

In such case, many systems (such as brake booster) cannot function. Driving in this way will form a danger to yourself and others.

### Pedal

To ensure that the pedal travel is unhampered, the floor mat in the pedal area shall not be excessively thick, and no article shall be placed in the pedal area.

### Emergency Measures

#### Caution

**The operation time of the starter motor shall not exceed 10s once. Otherwise, the starter motor will get damaged or discharge of battery will occur.**

### One Tyre is Punctured when the Vehicle is Running

If one tyre is punctured when the vehicle is running, the driver shall hold the steering wheel tightly to control the driving direction, slowly decelerate, turn on the hazard flasher, and gently depress the brake pedal to park your vehicle in a safe area.

#### Warnings

**Do not brake suddenly when one tyre is punctured. Braking suddenly will cause the vehicle to tilt towards one side, and thus an accident may be caused.**

### One Fault exists when the Vehicle is Running

If one fault exists when the vehicle is running, the driver shall turn on the hazard flasher, slowly decelerate, and park the vehicle in a safe area at the curb.

Place a warning triangle at a position 50 m behind the vehicle in the daytime while placing it at a position 100 m behind the vehicle at night. Please follow requirements of traffic laws and regulations.

After inspection, send the vehicle to the MG Authorised Service Center for inspection and maintenance.

Place the warning triangle in the trunk, or have the customer give it to you when the vehicle is being delivered.

### If the Engine Does Not Work

In case that the ignition switch is at the START position, if the starter motor does not work, please check whether the battery is dead,

whether the battery port is connected correctly and whether relevant fuses get damaged.

If the starter motor works but the engine fails to be started, please check fuel level, fuel filter, fuel pump, relevant wiring, etc. The operation condition of the fuel pump can be preliminarily judged by hearing sounds made by the ignition switch when it is being turned on.

### Measures Taken in Case of Engine Overheat

When the vehicle is running, if the output power of the engine reduces suddenly or the warning lamp on the instrument indicating excessively high temperature illuminates, park your vehicle in a safe area and take following measures:

- Have the engine run at idle, and turn the transmission at the neutral position.
- Pull the parking brake lever.
- Turn off the A/C.
- Open the bonnet to ventilate the engine bay.
- If the level of the coolant reservoir does not drop, stop the engine to cool it.
- If the coolant level is very low, uncover the reservoir, slowly fill water in the reservoir

drop by drop till the level reaches the MAX (maximum) level mark of the coolant reservoir.

- After taking provisional measures, immediately send the vehicle to the MG Authorised Service Center for inspection.

### Warnings

**Do not open the bonnet if steam or coolant overflows from engine parts. Otherwise, you may be scalded by steam or coolant.**

### Caution

**Suddenly filling cold water in the overheated engine will damage the engine. The handling method above is taken in case of an emergency. When the engine gets overheated, you are suggested to contact the MG Authorised Service Center for solution.**

### Caution

**When the engine gets heated, uncovering the coolant reservoir will get steam or coolant overflowed, and thus your face or other body parts may be scalded.**

**If you are to uncover the coolant reservoir, you can do it after the engine cools down completely. Apply one cloth to the cover, open it slightly at first (by 1/3-1/2), and then open it fully after pressure in the reservoir is released completely.**

### Operation in Heavy Snow

- Decelerate when the vehicle turns a corner, upgrades or crosses a bridge.
- Please avoid parking on a hard road shoulder; otherwise the snow shoveling work will be obstructed.
- Please keep safe distance from other vehicles; braking unnecessarily will be limited.
- Clear the accumulated snow around the vehicle frequently, for such measure can prevent the exhaust pipe from being blocked.

## Start and Operation

### Trial Run of New Vehicle

Following measures can be taken within the initial mileage of 500 km, which can improve the performance, promote the vehicle economy and extend the service life:

- Avoid starting the engine by depressing the accelerator fully.
- Do not keep the engine idling for a long time.
- Avoid any emergency shutdown except in an emergency. With this, the brake can run in well.
- Do not quickly start, accelerate suddenly and continuously keep the vehicle running at high speed if possible, to avoid any damage to the engine and save the fuel.
- Avoid accelerating by depressing the accelerator fully at a low gear and driving by depressing the accelerator greatly.
- Do not drag any other vehicle.

**Note**

Please do not use such vehicle electric equipment as audio and head lamp for a long time under the condition that the engine is off. When leaving the vehicle, please also shut down the electric equipment for the vehicle, to avoid the battery from running out. If the battery runs out, the vehicle may fail to be started.

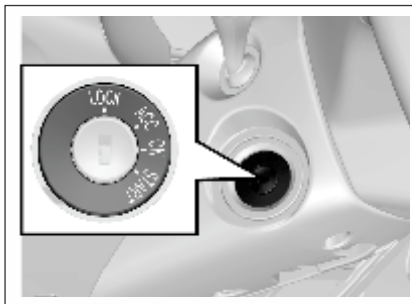
**Mechanical Ignition Switch Position\***

When the ignition switch is turned at the right side of the steering column, the operating positions are as follows: LOCK, ACC, ON and START.

- **LOCK**

Lock the steering wheel. Remove the key and turn the steering wheel till the steering wheel is locked.

If you cannot turn the key when unlocking the steering wheel, you can gently turn the steering wheel to right/left for one thing and turn the key for another.

- **ACC**

The engine can be shut down when the ignition key is turned to the ACC position without the need to lock the steering wheel.

If you are to turn the ignition key from the ACC position to the LOCK position, you can gently press in the key and turn the key to the LOCK position. When the ignition key is at the ACC position, some electrical accessories such as radio and cigar lighter can be used.

- **ON**

Connect the ignition system and electrical accessories.

**Note**

**Do not keep the key at "ON" for a long time when the engine is out of operation. Otherwise the battery will be discharged.**

- **START**

Start the engine. After starting the engine, release the key; the key will automatically return to the ON position.

Confirm that the engine does not operate before turning the ignition key to the START position.

**Caution**

Never remove the key or turn the key switch when the vehicle is running.

Otherwise, the brake assistance will disappear and the steering wheel may be locked. Therefore, the driver will lose control of the vehicle and thus the vehicle damage and the casualty accident may be caused.

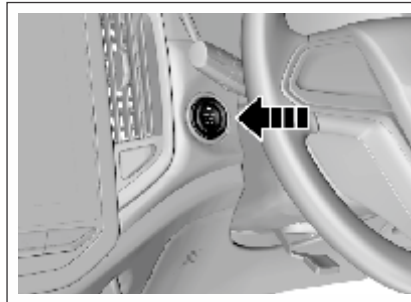
**ENGINE START STOP Switch Position\***

If equipped, the ENGINE START STOP switch is at the lower right side of the instrument cluster.

Working indicator on ENGINE START STOP switch:

Orange: It indicates that the ignition switch is at the ACC or ON position.

Green: It indicates that the start conditions are met.

When the working indicator turns green, if the transmission is at the neutral or P position, press the start switch and then the engine can be started.

When the power is switched from the low voltage to the high voltage, the system must be

able to detect the legal key. Please place the key at one position near the ENGINE START STOP switch inside the vehicle, such as driver's pocket or instrument panel storage box.

In the sequence from the low voltage to the high voltage of power, the operating positions are as follows: LOCK, ACC, ON and START.

- **LOCK**

Parking is carried out at the position. The working indicator on the ENGINE START STOP switch does not illuminate and the vehicle power is off.

- **ACC**

Press the ENGINE START STOP switch at the LOCK position; the position can be switched to the ACC position. The orange working indicator on the ENGINE START STOP switch starts to illuminate. At the position, power supplies of some electrical accessories such as audio and cigar lighter are connected.

If no operation is conducted, the system will automatically return to the LOCK position 1 h later, so as to reduce the consumed power.

- **ON**

Driving and start are conducted at the position.

Press the ENGINE START STOP switch at the ACC position once; the position can be switched to the ON position. The instrument cluster indicator illuminates, and the orange indicator on the ENGINE START STOP switch illuminates.

If you press the ENGINE START STOP switch once (without other operations) at the ON position, the switch will be turned to LOCK position.

- **START**

At the ON position, turn the transmission at the neutral position, and depress the clutch pedal (for MT model) or brake pedal (for AT model). Then the green indicator on the ENGINE START STOP switch illuminates. Press the ENGINE START STOP switch once, and the engine will start. After the engine starts, the ignition switch keeps at the ON position.

- **OFF**

Press the start switch once (vehicle speed < 2 Km/h).

Note
<p><b>Never keep the engine idling at high speed for over 5 min. Excess temperature will damage the exhaust system.</b></p>

Note
<p><b>For AT model, never release the brake pedal in the process of starting the engine; otherwise, the engine may fail to start. If the transmission is not at the neutral or P position, the engine cannot start.</b></p>

### Electronic Steering Column Lock\*

As the electronic steering column lock is used to lock the steering wheel, the vehicle having the ENGINE START STOP function is equipped with the electronic steering column lock at the same time. You can hear the operating sound when the lock device is started or released.

If locking the steering wheel is required, following conditions shall be met at the same time:

1. The vehicle is motionless
2. The ignition switch is at the LOCK position.

When conditions above are met, the steering wheel will be locked immediately if any one of following actions occur:

- Open or close the left front door.
- Remote locking
- Wait 24s later

If unlocking the steering wheel is required, you can just enter the vehicle with the legal key and press the ENGINE START STOP switch.

In case that the steering column lock may be unable to be released when it is in the wheel-deviation forward direction, the instrument cluster will display “Failure in locking of electronic steering lock” and buzz for prompt. At this time, align the steering wheel, turn the ignition switch at the ON position, and then switch to the LOCK position, to make efforts to unlock the steering wheel. If unlocking fails, check the vehicle.



## Engine Starting

Before starting the engine:

- Ensure that no barriers exist around the vehicle.
- Ensure that all windows and doors are clean and transparent.
- Check whether the tyre conditions and the inflation pressure are proper and whether foreign matters exist.
- Adjust the seat headrest to a proper position.
- Adjust the rearview mirrors inside / outside the vehicle.
- Fasten the safety belt and ask all passengers to fasten safety belts.
- When turning the key at the ON position, check the operating conditions of the warning lamp and the indicator on the instrument panel.
- Regularly (e.g., when refueling) check the maintenance items recorded in the Manual.

### Engine Starting:

1. Apply the parking brake.
2. Ensure that seats and rearview mirrors are at proper positions. Adjust them if necessary.
3. Turn the ignition switch at the ON position.
4. Ensure that the gear lever is at the neutral or P position, and then depress the clutch pedal fully. Please depress the brake pedal for the AT model.
5. Do not depress the accelerator pedal, turn the ignition-switch key to the ON position, and release the clutch (or brake) pedal after the engine starts. For one model having the ENGINE START STOP function, click the ENGINE START STOP switch once to start the engine. If the engine starts temporarily and fails to operate, you can wait for 10s and then try again.
6. Keep the engine idling for more than 30s to heat the engine.
7. Release the parking brake.
8. Do not drive the vehicle at high speed before the engine temperature reaches the normal operating temperature.

### Note

**Keep the engine idling for 3-5 min before the vehicle with the turbocharged engine starts to run, especially in winter or after storage for a long time, and after the engine oil is changed or the engine is maintained.**

### Note

- **Do not keep the starter running continuously for over 10s.**
- **It may be difficult to start the vehicle in extremely low temperature.**
- **It may be difficult to start the vehicle in one high-altitude area.**
- **If the engine fails to start, please wait for 10s and then restart so as to avoid any damage to the starter.**

### Turbocharged Engine Shutdown

After keeping the turbocharged engine operating at high speed for a long time, please firstly keep it idling for 3-5 min and then kill it, so as to cool the turbocharger. Otherwise, the turbocharger may get damaged due to overheat.

#### Note

**The turbocharged engine shall not idle for a long time. The idling time shall not exceed 20 min.**

### ENGINE START STOP Function\*

#### Start Condition

Following conditions shall be met for engine start:

1. The legal key is inside the vehicle;
2. Depress the clutch pedal (for MT model) or brake pedal (for AT model).

If conditions above are met, the green indicator on the ENGINE START STOP switch will illuminate. In this case, if the gear is at the neutral or P position, press the start switch and the engine will immediately start.

### Other Control Instructions

1. Emergency start
  - The brake or clutch switch failure will make the start conditions unable to be met, and thus the engine cannot start in the normal procedures. You can firstly turn the ignition switch at the ACC position, confirm that the transmission is at the neutral or P position, and then long press the ENGINE START STOP switch for 15s. In this case, emergency start of the engine succeeds.
  - Insufficient battery of the remote key may cause the system to fail to search for the key and thus the engine fails to start. In this case, you can firstly depress the clutch pedal (brake pedal for AT model), and at the same time attach the side of remote key close to the ENGINE START STOP switch. When the green indicator on the ENGINE START STOP switch illuminates, press the switch to start the engine. Please try again if you fail. You shall replace the battery of the remote key.

### 2. Emergency flameout

If emergency flameout of the engine is required when the vehicle is running, you can long press the ENGINE START STOP switch for 2s or continuously press for 3 times within 3s.

#### Caution

**Never have a kid operate the ENGINE START STOP switch in any case; otherwise unexpected start or flameout of the vehicle, and the vehicle damage and the casualty accident may be caused.**

#### Caution

**Never operate the ENGINE START STOP switch when the vehicle is running. Accidental vehicle flameout may suspend braking and assistance of the steering system. In this case, the driver will lose control of the vehicle and thus the vehicle damage and the casualty accident may be caused.**

### Cruise Control System \* Type-I Switch

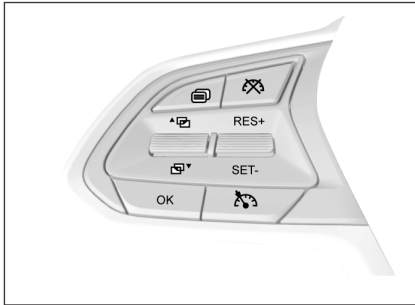



### Type-II Switch





As the switch of cruise control system is at the steering wheel, when the cruise control system is started, the vehicle can run at such speed. Depress the brake pedal, and the function will be immediately disabled. Except that the brake pedal is used to disable the function, operating switches such as parking brake switch and clutch switch can also be used to disable the function of the cruise control system. The system can be used at 3, 4, 5 and 6 gears with the speed range of 40 Km/h - 120 Km/h when the engine speed is lower than 4800 rpm. For the AT model, the minimum speed for starting the cruise application system is 48 Km/h. Specific application method:

#### First Step: Cruise Start

Based on the cruise control system switch type, press the “” button or pull the toggle button towards “” direction, and then the cruise indicator on the instrument cluster starts flickering, indicating that the cruise control system enters the activated state; pull the middle button towards the “SET/-” direction, and the cruise start succeeds and the cruise indicator of instrument is normally on. (For example, when the driver intends to

stabilize the speed at 100 km/h, the driver must firstly speed up to 100 km/h. When the speed reaches 100 km/h, he/she shall press the “” toggle button and then pull the toggle button towards the “SET/-” direction. At this time, release the accelerator pedal, and the vehicle will continuously run at the speed of 100 km/h). After setting the cruising speed, you can also use the accelerator pedal to accelerate in the normal method; after the accelerator pedal is released, the system will recover the speed to the original cruising speed.

#### Second Step: How to Deactivate Cruise

If you are to immediately decelerate in case of any emergency in front during cruise control, you can depress the brake pedal or clutch pedal, or press the cruise deactivation button “” or pull the toggle button towards “” direction. In this case, the vehicle exits from the current cruise state and enters the cruise activation state, and the cruise indicator of instrument flickers; if you press the “” button in the cruise state, the whole cruise system will be deactivated and the instrument indicator will go out.

### Third Step: Operation for Cruise Recovery

When the vehicle exits from the cruise state and enters the cruise activation state, if you are to carry out the cruise control at the previous cruising speed, you just need pull the toggle button once towards the “RES/+” direction. Then cruise control is carried out at the previously-saved speed recovered. For example, the cruising speed is 60 Km/h before braking and becomes 50 Km/h after braking, and at the time the cruise indicator of instrument flickers. Pull the toggle button once towards the “RES/+” direction; the cruise indicator will be normally on, and the vehicle will automatically speed up to 60 Km/h and enter the cruise control state.

### Fourth Step: How to Promote Cruise Control Speed

Pull the toggle button towards the “RES/+” direction and the set cruising speed will rise without the need to depress the accelerator pedal. The speed will rise by 2 km/h every time you pull up the switch once. If the toggle button is kept pressed, the vehicle speed will continuously rise. Once the switch is released, the then running speed will be saved into the memory and the vehicle will cruise at the speed.

### Fifth Step: How to Reduce Cruise Control Speed

Pull the toggle button towards the “SET/-” direction to reduce the cruising speed. The speed will reduce by 2 km/h every time you pull down the switch once. If the toggle button is kept pressed, the vehicle speed will continuously reduce. Once the control lever is released, the then running speed will be saved into the memory and the vehicle will cruise at the speed. If the toggle button is released when the vehicle speed reduces to about 40 km/h (less than 40 km/h), the saved value will be deleted. If you are to continuously drive at the cruise control speed, you need reset the cruising speed.

#### Caution

**In principle, the cruise control system can be used on one expressway or one totally-closed road. It is not allowed to use the cruise control system in rainy, icy and snowy weather, and on one densely-hillside road or densely-crooked road. Cruise control is also not proper on a rugged pavement and when too many vehicles run on one road.**

#### Note

**For the MT model, after the cruise control system is started, if you intend to shift the transmission to the neutral position, always depress the clutch pedal firstly. Otherwise, it may cause the engine to overspeed and thus get damaged.**

### Engine Immobilizer System

The vehicle with the engine immobilizer system has the extra anti-theft capacity, for the system can prevent any unauthorized person from starting the vehicle. The matching key of the engine immobilizer system has been encoded electronically. The electronic transceiver is concealed in the ignition key. Only a valid key can be used to start the engine. However, an invalid key can also be used to open doors. The engine immobilizer system isolates the power supply from the ignition system, the fuel pump and the fuel injector. When any unauthorized person turns the invalid key to the START position, the engine immobilizer system fails to identify the electronic code. Therefore, the engine cannot start and the immobilizer system indicator will be flickering.

**Note**

If the vehicle is equipped with one steering wheel mechanical lock again, a better anti-theft result will be realized.

**Parking**

- When the parking brake is used for parking, the button shall be released after parking. When parking on a ramp, tension the parking brake as tightly as possible and depress the brake pedal at the same time.
- Shut down the engine and turn off the ignition switch. Turn the steering wheel till the steering wheel is locked by the steering wheel lock.
- When parking the vehicle on one uphill ramp, turn the front wheels away from the road shoulder. When parking the vehicle on one downhill ramp, turn the front wheels towards the road shoulder.
- When parking the vehicle on one downhill ramp, turn the front wheels towards the road shoulder.

**Caution**

Do not park and drive the vehicle on inflammables such as straw and hay. If such inflammables cannot be avoided, park the vehicle to check and confirm that these inflammables are not attached at the chassis after the vehicle passes the inflammables.

**Otherwise, these inflammables may be ignited by high-temperature components on the chassis, and thus a fire accident is caused.**

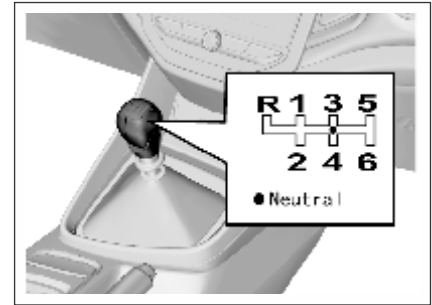
**Manual Transmission\***

Shift the gear as per gear positions marked on the gear lever ball after the clutch is released. If you have to shift to the reverse gear, you must firstly stop the vehicle, depress the clutch, and shift the gear lever from the neutral (N) gear to the reverse (R) gear.

1: First drive gear 2: Second drive gear

3: Third drive gear 4: Fourth drive gear

5: Fifth drive gear 6: Sixth drive gear (if any)

R: Reverse gear

Depress the clutch pedal completely when shifting gear. Do not always put your foot on the clutch pedal during driving.

### Operation for Shifting Transmission with Six Drive Gears to Reverse (R) Gear

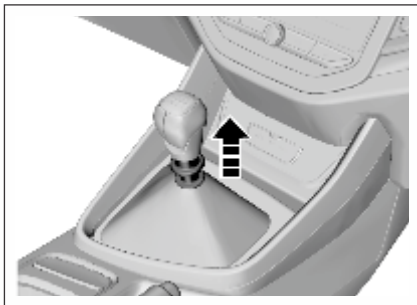

As shown in the figure above, when shifting the transmission with six drive gears to the reverse (R) gear, pull up the reverse gear lock ring firstly and then turn the gear lever from the neutral (N) gear to the reverse (R) gear. Take care not to pull the reverse gear lock ring when shifting to the drive gear, so as to avoid from shifting to the reverse gear accidentally.

#### Note

**When shifting between the drive gear and the reverse gear, be sure to ensure that the vehicle comes to a complete stop. After completely depressing the clutch, wait for a moment and engage a gear.**

**Otherwise, the transmission may get damaged or the transmission service life may be shortened.**

#### Note

**When reversing your vehicle, please slowly start and confirm that the vehicle is shifted to the reverse (R) gear, for engaging a wrong gear may cause an accident.**

#### Warnings

**Always putting your foot on the clutch pedal during driving will damage the engine and the clutch system and increase the consumed fuel volume.**

#### Caution

**Do not slide your vehicle at the neutral gear; otherwise, the transmission will get seriously damaged or an accident will be caused.**

### Automatic Dual Clutch Transmission (DTC) \*

Your vehicle may be equipped with one automatic dual clutch transmission, which is a wet automatic dual clutch transmission with 6 gears.

#### Instruction for Use

1. Before starting the engine, depress the brake pedal firstly to confirm that the transmission gear lever is at the P gear, and then the engine can be started.
2. Depress the brake pedal and then engage gear after you start the engine.
3. Continuously depress the brake pedal after you engage gear, release the electronic parking brake, and release the brake pedal after you are ready to start the vehicle.
4. After the brake pedal is released on a smooth pavement, the vehicle will start running automatically and slowly with the accelerator pedal not depressed.
5. Sliding your vehicle at the neutral gear is prohibited during driving; otherwise, the transmission will get seriously damaged or an accident will be caused.

## Shifting

### Locking Button

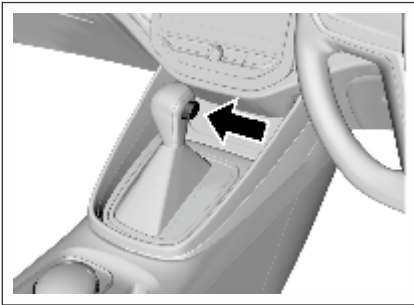

Only one locking button exists on the gear lever, and this button is used to avoid the driver from selecting the parking (P) gear or reverse (R) gear when the vehicle runs at other gears.

Do not press the button while the vehicle is running.

It is required to press the button only when the vehicle comes to a complete stop and you intends to engage the parking (P) gear or reverse (R) gear.

### Gear Lever Operation

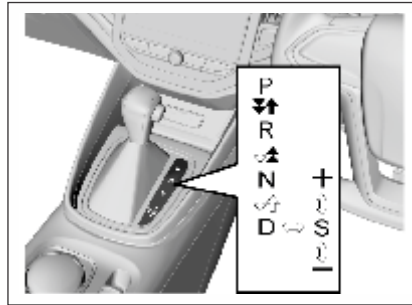

Operate the gear lever as indicated by arrows below when shifting gear.

- Shift gear freely.
- Press and hold the locking button to shift gear.
- Press and hold the locking button and at the same time depress the brake pedal to shift gear.

**Note:** The requirements for operations to switch the neutral (N) gear to the drive (D) gear are relevant to the vehicle speed and the duration of the gear lever at the neutral (N) gear. In some cases, you have to depress the brake pedal and then the neutral (N) gear can

be switched to the drive (D) gear. For example, the duration of the gear lever at the neutral (N) gear is over 2s when the vehicle is 5 km/h.

## Gear

### P: Parking Gear

The transmission is locked mechanically at the parking gear. Engage the parking (P) gear when the vehicle is motionless and the hand brake is drawn back.

### Note

**When you park your vehicle on a ramp, you should firstly depress the brake pedal and draw back the hand brake, and then engage the parking (P) gear.**

### R: Reverse gear

The reverse (R) gear can be engaged only when the vehicle is motionless and the engine idles.

### N: Neutral Gear

The neutral (N) gear can be engaged when the vehicle is motionless and the engine idles for a long time (for such purposes as waiting for a traffic light or for a traffic jam).

**D: Drive Gear (Economy Mode)**

It is used for normal driving. The transmission automatically selects among 6 drive gears according to the vehicle speed and the accelerator pedal position.

The economy mode among the automatic modes is selected at the gear. The optimum fuel consumption and discharge can be provided in the economy mode.

**S: Drive Gear (Sport Mode)**

Turn the gear lever from the (D) position right to the (S) position. The sport mode among the automatic modes is selected at the gear. The better operating performance can be provided in the sport mode. You can also switch to the manual mode at the gear.

**+/-: Upshift / Downshift in Manual Mode**

If you are to toggle the gear lever from the (S) position to the (+) or (-) position once, select the manual mode.

After selecting the manual mode, toggle the gear lever to the (+) position once, and one gear will be increased. If the vehicle speed is excessively low, the system will not implement the upshift command and the instrument will ring for prompt. It is recommended to upshift manually when the engine speed is 1600–2000 rpm.

Toggle the gear lever to the (-) position, and one gear will be reduced. If the vehicle speed is excessively high, the system will not implement the downshift command and the instrument will ring for prompt.

If the gear lever is toggled from the (S) position to the (D) position, the vehicle is switched to the automatic gearshift mode.

When the vehicle runs in the manual mode, if the engine speed is lower than one constant value, the transmission will automatically downshift to the adjacent low gear, so as to avoid the engine flameout from occurring. When the vehicle speeds up, and the engine speed continuously rises and reaches to the maximum speed allowed within gears, the transmission will automatically upshift to the adjacent high gear, so as to protect the engine.

**Dangers**

**Switching the gear lever from the drive (D) gear to the reverse (R) gear or parking (P) gear is prohibited during driving; otherwise, the transmission will get seriously damaged or an accident will be caused. Only when the vehicle comes to a complete stop can the reverse (R) gear or parking (P) gear be engaged.**

**Gear Display**

P	Parking
R	Reverse
N	Neutral
D	D: Drive A: Automatic mode E: Economic mode S: Sports mode
1	M: Manual operation 1: Gear position

The gear information is shown on the instrument cluster display.

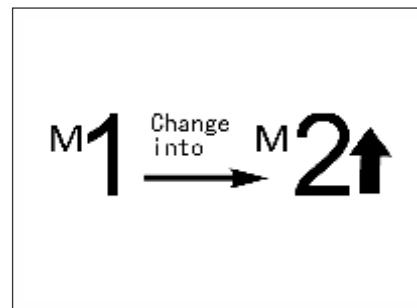
**Upshifting Reminding**



As shown in the figure above, when the vehicle is running in the manual mode, if the vehicle speed is excessively high at the current gear, the instrument will ring for upshift reminding. Take the figure above as an example, the instrument reminds you to upshift from Gear 1.

### Vehicle Start

When you start the engine and switch it to one required gear, release the hand brake and the brake pedal, and the vehicle will start running automatically and slowly. You can start the vehicle from Gear 2 in the manual mode on a snowfield so that front wheels slip less.

### Automatic Upshift

After you select the drive (D) gear to drive the vehicle, the time for automatic upshift of transmission is relevant to the opening of accelerator pedal depressed.

If the accelerator pedal is depressed slightly, the transmission will shift gear at the relatively low speed; if the accelerator pedal is depressed drastically, shifting of the transmission will be delayed, and the transmission will shift gear till the relatively high speed is reached.

### Kick-down

After you select the drive (D) gear to drive the vehicle, if you depress the accelerator pedal fully (such as for overtaking), the transmission will immediately switch to a proper lower gear at some speeds, which makes acceleration quicker. Release the pedal after acceleration, and the transmission will return to the proper high gear (according to the vehicle speed and the accelerator pedal position).

#### Caution

**Activating the kick-down function on such low-adhesion roads as smooth pavement may cause drive wheels to slip and bring in the sideslip danger.**

### Hill-Start Hold Control

The electronic parking brake (EPB) system can help you to start the vehicle on a ramp. When you stop the vehicle on a slope, please draw back the hand brake and fasten the safety belt. When you are ready to start the vehicle, depress the brake pedal and engage the required gear (D/R gear), release the brake pedal and depress the accelerator pedal. Then the electronic parking brake (EPB) system will automatically function and the vehicle starts running smoothly. Please refer to contents in

Section “Electronic Parking Brake (EPB)” under Chapter “Driving and Controls” for details.

Besides, the hill-start hold control (HHC) system can also help you to start the vehicle on a steep slope. Please refer to contents in Section “Hill-start Hold Control (HHC) System” under Chapter “Driving and Controls” for details.

#### Caution

**When the vehicle stays on a ramp (i.g., in case of a traffic jam), you shall not prevent the vehicle from sliding backward by throttling up the engine; otherwise, the automatic dual clutch transmission may get overheated and damaged. Please apply the hand brake or depress the brake pedal.**

### Run Downhill

If you depress the brake pedal continuously for a long time, the brake may get overheated, and thus the braking performance may be reduced and be invalid. When the vehicle is running down a long slope, after you depress the brake pedal to reduce the vehicle speed, push the gear lever from the drive (D) gear right into the (S) position and toggle it to the (-) position, and engage a low gear.

In this way, the braking function of engine can be activated to reduce the vehicle speed, and thus the load of brake is lowered.

### Protection Mode

#### Transmission Overheat Protection

If the vehicle starts frequently in the hot environment or when the transmission is in the overload state, the automatic dual clutch transmission may get very hot.

To avoid any damage to the transmission, the system will activate the overheat protection function, and at the same time the instrument cluster emergency parking (EP) indicator will illuminate or display the relevant warning icon and information accompanied with alarm sounds. In this case, please park the vehicle

safely and switch to the P gear to cool the transmission.

If the instrument cluster warning information remains the same or still exists 20 min later since you operate as per the information tips above, please contact the MG Authorised Service Center for overhaul as soon as possible. Otherwise, the transmission may get seriously damaged.

#### Limp Home Mode

When some faults exist on the transmission, the transmission will enter the limp home mode (in this case, it can work only at some gears, and the vehicle may be unable to run at the reverse (R) gear in individual cases), and the transmission MIL of instrument cluster illuminates. If the transmission enters the limping mode, please contact the MG Authorised Service Center for overhaul as soon as possible.

Do not shift gear manually in the limp home mode.

### Serious Functional Fault

When some serious functional faults exist on the transmission, the system will cut off power transmission from the engine to the clutch forcibly for the purpose of transmission protection, and thus the vehicle will be unable to run! If the transmission enters the limping mode, please contact the MG Authorised Service Center for overhaul as soon as possible.

Note
<p><b>The instrument cluster emergency parking (EP) indicator and the transmission MIL illuminate, indicating that the transmission gets seriously overheated or some functional faults exist on the transmission. Please park the vehicle safely and contact the MG Authorised Service Center as soon as possible.</b></p>

### 48V Hybrid Power System\*

The 48V hybrid power system has the following functions: auto engine start-stop, assist power, and energy recovery. It can improve the fuel economy, and enhance the driving experience. Normal operating temperature of the vehicle:  $>-30^{\circ}\text{C}$ .

#### Start / Stop function

The start-stop function can control the engine flame-out and start, and reduce unnecessary idle conditions to improve the fuel economy according to the corresponding driving conditions. To enable the start-stop function, the following preconditions must be met:

1. The engine hood is closed.
2. The driver side door is closed.
3. The driver seat belt is fastened.
4. Such conditions as ambient temperature, engine coolant temperature, and vacuum brake pressure are met.

#### Auto Engine Flame-out

If the vehicle speed drops to 0 km/h, the neutral is set, and the clutch is release under the above preconditions and without no-stop conditions, the engine will automatically flame out. (The highest vehicle speed before stopping is greater than 14 km/h)

### Auto Engine Start

After the engine automatically flames out, the engine can be started by any one of the following operations:

1. Depress the clutch pedal.
2. Depress the accelerator pedal.
3. Rotate the steering wheel by more than  $100^{\circ}$ , or rapidly rotate the steering wheel.
4. Continuously depress or stomp on the brake pedal.

#### Disabling of Start-Stop Function

After the ignition switch is put at "ON", the start-stop system enters the standby state. If the conditions are met, the engine will automatically start and stop. If you do not want the engine to automatically start and stop, the following operations can be taken:

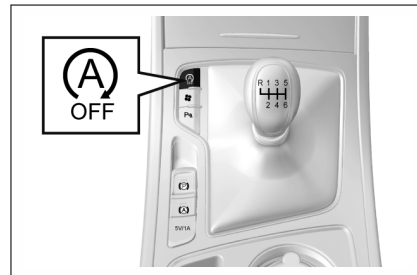

After starting the engine, press the start-stop disabling switch, as shown in the figure. The start-stop system OFF indicator on the instrument cluster turns on, and the start-stop function is disabled. Press the switch again to enable the start-stop function again.

#### Description

#### Auto Start / Stop will not work in following conditions

Giving priority to comfort over fuel efficiency, this feature will not work with AC ON condition to prevent any discomfort to customer in hot summer and prolonged stop-go situations in cities.

In case of any one of the following situations, the start-stop function will be disabled, and the engine will not automatically stop:

1. The start-stop disabling switch is pressed.
2. Engine coolant temperature is lower than  $36^{\circ}\text{C}$ .
3. AC is switched ON condition.
4. The brake is depressed.
5. 48V battery voltage is low.
6. 48V battery system error.

7. The rate of rotation of the steering wheel is greater than a certain value.
8. Vehicle speed signal invalid.
9. The rear / front windshield defrosting function is enabled.
10. The vehicle is on the slope.
11. The ambient pressure is low.
12. ESC works.

### Situations of Auto Engine Start

After the engine automatically stops, when the vehicle is in any one of the following states (AC should be in switched off condition), the engine will automatically start:

1. 48V battery voltage is low.
2. The stop time is more than 300s.
3. Unbuckle the driver side seat belt.
4. Open the driver side door.

After the engine automatically stops, if the engine hood is open, the engine will not automatically start. The engine must be started manually.

### Dangers

**After automatic stop, although the engine already flames out, the vehicle is still in operation. The engine may start at any time. In case of the following behaviors, firstly turn off the vehicle power or pull out the key:**

1. The driver leaves the vehicle.
2. The body extends to the engine compartment.
3. The vehicle is refueled.

### Caution

**When driving through water, please make sure to disable the start-stop function.**

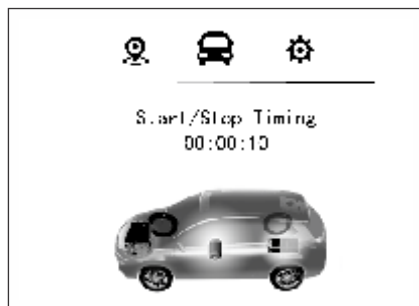
**Start-Stop Timing**

The start-stop timing displays the accumulated time of the auto engine stop after the ignition switch is switched on.

The start-stop timing function starts to display only when the start-stop working indicator turns on. The maximum display is 99:59:59. It will restart timing if the value exceeds the maximum.

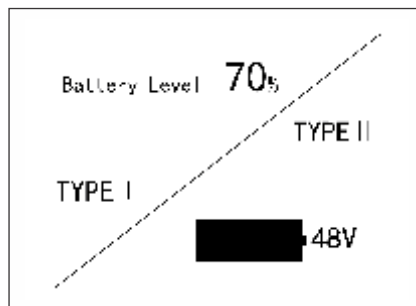
**Battery Capacity**

Display the 48V battery capacity.

The 48V power battery is located below the front passenger seat.

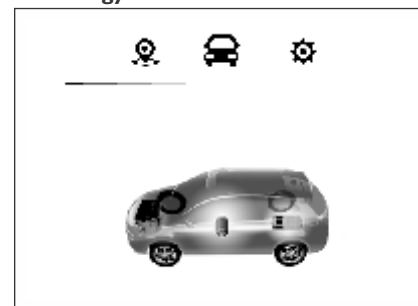
**Energy Flow Display  
No-energy Flow Mode**

Represent that there is no energy flowing because the engine flames out.

**Standby Mode**

Represent that there is no energy flowing.

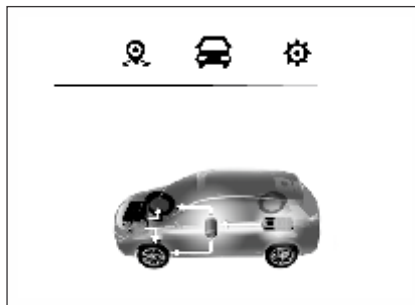
**Assist Power Mode**

When the engine speed is lower ( $<1,800$  r/min), and the 48V battery capacity is greater than 40%, the driver speeds up at full accelerator (opening  $>70\%$ ). The system enters the assist power mode to improve the vehicle acceleration performance. When the engine speed is greater than 2,000 r/min, exit the assist power mode.

The assist power mode will also be enabled under other conditions to reduce the fuel consumption.

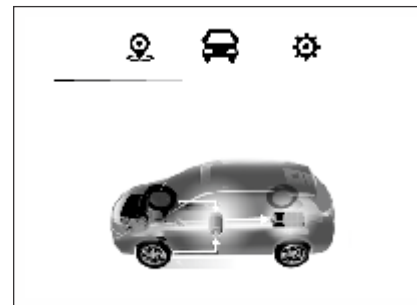
**Energy Recovery Mode**

When the vehicle speed is greater than 20 km/h during sliding and braking, without depressing the clutch, the system can recover a part of braking energy to store in the 48V battery pack, improving the fuel economy of the vehicle.

## Automatic Transmission

### Continuous Variable Transmission (CVT)

Your vehicle may be equipped with a Continuous Variable Transmission (CVT). A CVT can continuously change the transmission ratio, which is equivalent to having innumerable gears, making gear shifting smoother.

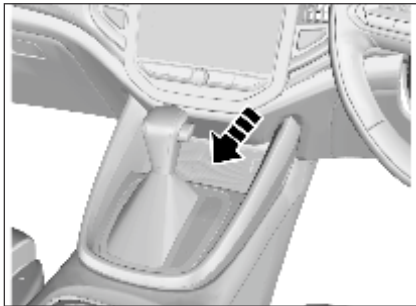

### Instruction for use:

1. Before starting the engine, depress the brake pedal firstly to confirm that the transmission gear lever is at the P gear, and then the engine can be started.
2. Depress the brake pedal and then engage gear after you start the engine.
3. Continuously depress the brake pedal after you engage gear, release the electronic parking brake, and release the brake pedal after you are ready to start the vehicle.
4. After the brake pedal is released on smooth pavement, the vehicle will start running automatically and slowly with the accelerator pedal not depressed.
5. It is forbidden to coast in neutral gear during driving. Otherwise, the transmission will be damaged or an accident will occur.

### Selector Lever

There is a locking button on the gearshift to prevent the wrong choice of P or R in other gears.

Do not press the button during the driving process. Press this button only when the vehicle is stationary and you intend to put it in either P gear or R gear.

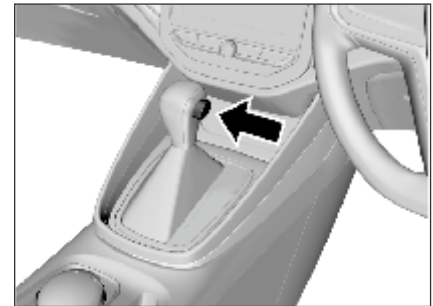

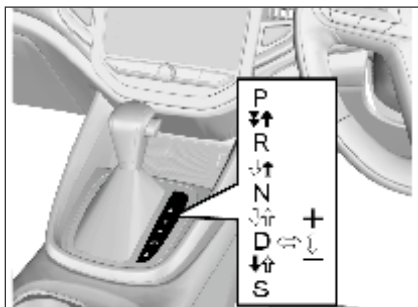

Operate the gearshift as indicated by arrows below when shifting gears:

⇨ Shift gears freely.

➡ Press and hold the locking button to shift gears.

⏴ Press and hold the locking button while depressing the brake pedal to shift gears.

## GEAR

### P: Parking Gear

The transmission is locked mechanically at the parking gear. Engage P gear when the vehicle is motionless and the hand brake is pulled.

### Note

When parking the vehicle on a ramp, press the brake pedal first and pull the hand brake before putting the vehicle in P gear.

### R: Reverse Gear

The reverse (R) gear can be engaged only when the vehicle is motionless and the engine idles.

### N: Neutral

Put the vehicle in N gear when it is stationary and the engine idles for a long time (for such purposes as waiting for a traffic light or for a traffic jam).

### D: Drive Gear (Normal Mode)

It is used for normal driving. The transmission automatically stays at the best transmission speed ratio according to the vehicle speed and the accelerator pedal position. The gear is selected in the normal mode under the automatic mode. The normal mode can provide relatively balanced fuel economy and operation performance.

### S: Drive Gear (Sport Mode)

Move the gearshift from position (D) to position (S). Select sport mode under the

automatic mode, which can provide better operating performance.

### M: Manual Shift Mode

Select the manual mode when the gearshift is moved to the right position (+/-) from position (D). After selecting the manual mode, move the gearshift to (+) once to raise one gear. If the vehicle speed is excessively low, the system will not implement the upshift command and the instrument will sound for prompt.

It is recommended to change into a higher gear manually when the engine speed is 1600–2000 RPM.

Move the gearshift to position (-) once to lower the gear. If the vehicle speed is excessively high, the system will not implement the downshift command and the instrument will sound for prompt.

If the gearshift is moved to position (D) at position (+/-), then switch to the automatic shift mode.

There are 8 drive gears (highest gear: 8th gear) in the manual mode.





When the gearshift is in D position, press the ECO button, and the transmission will automatically select the best transmission ratio to provide the best fuel consumption and emission.

### Warnings

- **Do not press the accelerator pedal while shifting from P (Park) or N (Neutral) to R (Reverse), D (Drive) or L (Low). Always press the brake pedal until shifting is completed. Failure to do so could cause you to lose control and have an accident.**
- **Cold engine idle speed is high, so use caution when shifting into a forward or reverse gear before the engine has warmed up.**
- **Do not downshift abruptly on slippery roads. This may cause a loss of control.**
- **Never shift to either the P (Park) or R (Reverse) position while the vehicle is moving forward, and P (Park) or D (Drive) position while the vehicle is reversing. This could cause an accident or damage the transmission.**
- **Except in an emergency, do not shift to the N (Neutral) position while driving. Coasting with the transmission in the N (Neutral) position may cause serious damage to the transmission.**

### Gear Display

<b>P</b>	<b>R</b>	<b>N</b>	<b>E D</b>	<b>S</b>	<b>M 1</b>
Parking	Reverse	Neutral	8-SDS Mode Sports	Sport Mode	Manual Mode Lock, Park, L

The gear information is shown on the instrument panel cluster display.

### Vehicle Start

When the engine starts and a required gear is switched to, the vehicle will start and move automatically and slowly after the hand brake and brake pedal are released.

### Hill-start Control

The electronic parking brake (EPB) system can help you to start the vehicle on a ramp. When stopping the vehicle on a slope, please pull the hand brake and fasten the seat belt.

When preparing to start, depress the brake pedal and engage the required gear (D/R gear), release the brake pedal and depress the accelerator pedal. Then the EPB system will automatically function and the vehicle starts running smoothly. See Electric Parking Brake

\*\*

**Caution**

**When stopping the vehicle on an uphill grade, do not hold the vehicle by pressing the accelerator pedal. The foot brake should be used for this purpose**

**Downhill Driving**

If the brake pedal is pressed continuously for a long time, it may cause the brake to overheat, thus reducing or even failing the braking effect.

When the vehicle drives downwards along a long slope, push the gearshift to the right from D gear to position (+/-) and move it to position (-), then engage a low gear. In this way, the braking function of engine can be activated to reduce the vehicle speed, thus reducing the brake load.

**Protection Mode****Transmission Overheating Protection**

If the vehicle starts frequently in a hot temperature or when the transmission is overloaded, the automatic transmission may get very hot.

To avoid transmission damage, the system will perform overheating protection function. At this time, the vehicle power will be limited. Smooth driving behavior is recommended while violent driving should be avoided.

If the warning message of the combination instrument still does not change or disappear after 20 minutes of operation according to the above information, please contact your dealer for maintenance as soon as possible.

Otherwise, the transmission will be seriously damaged.

**Limp Mode**

When some faults occur in the transmission, it will enter the limping mode. At this time, the transmission can only work at a specific speed ratio. There will be a strong sense of impact when gear shifting of the transmission occurs. The fault warning lamp of the transmission of the combination instrument will be on.

If this happens to the transmission, please contact the Aftersales Service Center for repair as soon as possible.

**Note**

When the transmission failure indicator light of the combination instrument flashes, it indicates that the transmission oil temperature is too high (over 140 °C) or too low (lower than -30 °C). At this time, smooth driving is recommended and rapid acceleration should be avoided.

**Note**

When the transmission failure indicator light of the combination instrument is on, it indicates that there is some functional fault in the transmission. See your dealer as soon as possible.

## Intelligent Charging Mode

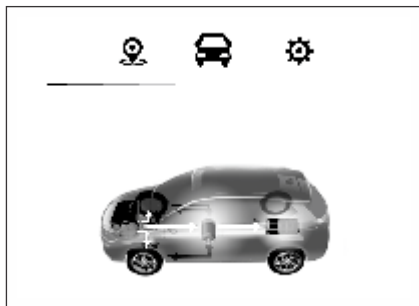

In the intelligent charging mode, the system charges the 48V battery.

### Fault Mode

When the 48V hybrid power system fails, the fault warning lamp turns on, and the corresponding prompt appears on the instrument. The vehicle enters the limp home mode. The torque output is limited, and the vehicle cannot accelerate. Please immediately drive to the Service Center for inspection.

## Brake

The brake system is designed for the braking performance under the driving conditions in wide range. In the braking process, the vehicle speed is reduced through the braking friction and the friction between tyres and ground. It is normal that small braking friction sounds and friction sounds between tyres and ground are given with no need for special treatment. It is also normal that occasional squeals are given in braking. Squeals may be produced for such causes that other matters may adhere to the friction faces during operation of the vehicle, the vehicle is out of operation for a long time, or friction faces get rusted after raining. As long as squeals are produced at a lower frequency, there is no need for special treatment.

To avoid the pedal travel from being influenced, do not lay a thick carpet in the brake pedal area.

If you find that the brake pedal fails to return or the brake pedal travel becomes longer, we strongly advise you to have your vehicle inspected at the MG Authorised Service Center. This may indicate a faulty brake system.

### Note

**When you drive your vehicle in one high-altitude area, continuously braking may cause the brake pedal force to increase.**

### Note

**To run in the friction plate and the brake disc and confirm the performance and the service life, after purchasing a vehicle and installing new friction plates, you had better avoid emergency braking or braking for a long time within millage of 200 km.**

### Warnings

**Please check whether the brake lamp is normal before driving your vehicle. Keep the vehicle running at low speed after starting the vehicle, and check the braking performance. You shall do more like this especially after your vehicle is just washed. The wet brake may cause an accident. In case the brake is wet, the brake fails to function well and thus the vehicle may be out of control due to lateral deviation. Therefore, after driving through water or having your vehicle cleaned, keep the vehicle running at low speed and depress the brake pedal intermittently and gently, so as to dry the brake.**

If the brake is unable to brake temporarily due to overheat.

Engage a lower gear when driving downhill and use the engine to brake.

If the brake is unable to brake temporarily due to wet components, the normal performance can be recovered with the help of following procedures:

1. Check whether there are vehicles behind your vehicle.
2. Keep safe driving speed to ensure there is sufficient space behind your vehicle and at both sides of your vehicle.
3. Carefully depress the brake till the normal performance is recovered.

### Anti-lock Brake System (ABS)

As one advanced electric braking system, the anti-lock brake system (ABS) is helpful in avoiding the vehicle from slipping and losing control, and this system can also provide the maximum braking capability on the slipped pavement.

When the ignition switch is turned on, the ABS warning lamp illuminates momentarily. The ABS warning lamp does not go out or illuminates when the vehicle is running, it indicates that the ABS is faulted. Please immediately contact the MG Authorised Service Center. Refer to “ABS Warning Lamp” under Chapter “Instrument and Control Device”.

The ABS will monitor the speed of each wheel during braking. If one wheel tends to be locked, the system will control brakes of two front wheels and two rear wheels respectively. When the ABS works, the brake pedal often vibrates slightly with noise.

#### Warnings

**If the ABS gets faulted, it may be unable to function, wheels may be locked in case of emergency brake, and the vehicle may be unable to steer or may steer suddenly.**

#### Warnings

**The ABS will neither change the time required for brake engagement, nor shorten the braking distance. Sufficient braking distance must be kept even the ABS is equipped.**

### Electric Brake Force Distribution (EBD) System

The EBD system uses the high-speed computer to respectively induce and calculate different ground to which four wheels are attached, and thus calculate different friction values at the moment the vehicle brakes. Therefore, four wheels can be able to brake in different ways and force based on different conditions, and can be adjusted fast during movement, so as to ensure that the vehicle is stable and safe.

### Electronic Stability Control (ESC) System

The ESC system is a new-type active safety system, representing the further development of the functions of anti-lock brake system (ABS) and traction control system (TCS). In addition, the yaw rate sensor, lateral acceleration sensor and steering wheel turn

angle sensor are added. The driving force and braking force of front and rear, left and right wheels are controlled through the ECU, which ensures the lateral stability of the vehicle. When the driver operates the vehicle beyond the limit values, in case of turning at high speed, the ESC system automatically intervenes to ensure that the vehicle returns to be controllable and ensure the safety. Indicators relevant to the ESC system include ABS fault indicator, EBD fault indicator, ESC indicator and ESCOFF indicator.

1. Indicators illuminate for self-inspect when the ignition is connected. The 4 indicators are normally on for 3s, indicating that the ESC system is conducting self-inspect and indicators work normally. The 4 indicators go out 3s later under the normal condition. When faults (such as neglected installation, loosened connector, abnormal CAN communication) exist on the ESC system, only the ESC OFF lamp will go out 3s later, and other 3 lamps are normally on.
2. During driving, if the ESC function is activated, the ESC indicator will flicker, telling the Owner that the ESC system is

working. If the ESC system functions abnormally but the ABS+EBD system functions normally, the ESC indicator is normally on, indicating that the ESC system gets faulted. If the ESC system and the ABS function abnormally but the EBD system functions normally, the ESC and ABS indicators are normally on. If the ESC system, the ABS and the EBD system function abnormally, the ESC, ABS and EBD indicators are normally on.

3. The ESC OFF lamp is used to indicate that the ESC function is disabled (the lamp will be normally on so long as the ESC function is disabled; the lamp will go out if the function is enabled). If the user presses the ESC OFF switch, some ESC functions will be disabled, and the ESC OFF lamp illuminates. When the switch is pressed, the ESC system is working, and the ESC function will not be disabled immediately and will be disabled after the work is over. If the user presses the ESC switch again, all functions will be enabled again. If the pressed time of ESC switch exceeds 10s, the ESC system will consider it as one incorrect operation (for example, the

switch is pressed by one unknown article incautiously), the ESC function will not be disabled.

4. The ESC system will be activated automatically after every re-ignition.

#### Note

**The ESP system may not be able to help you escape from out-of-control in the ultimate state for sure. Therefore, take care during daily driving.**

**You had better disable the ESP system when crossing country on a sandy and rocky pavement. As it is time for the ESP system to function on an icy, snowy and slippery pavement, the ESC system shall not be disabled.**

## ESC OFF Switch



Press the ESC OFF switch after starting the vehicle. The ESC OFF lamp on the instrument cluster turns on, and some ESC functions are disabled. Press the ESC switch again, the ESC function is enabled again and the ESCOFF indicator on the instrument cluster goes out.

Normally, it is not recommended to disable the ESC system. The system should be disabled temporarily only when the vehicle gets out of the mire or the vehicle climbs on a snowfield, etc.

### Hill-start Hold Control (HHC) System \*

The ESC system has the HHC function. The function can help the vehicle to start easily on a slope without using the parking brake.

Whether the driver is driving or reversing onto a hill, the start assistant is provided through the function. Therefore, engage gear before starting, please.

When the hill-start hold control functions, after the brake pedal is released, the vehicle still keeps the braking force for 1-2s. In this case, the vehicle will not slide backwards. For one MT vehicle, the driver can focus on engagement of accelerator and clutch in 2s, so as to deal with the tense hill-start with ease.

In this 2s, if the driving force applied by the driver is greater than the resistance which the vehicle is subject to when running onto a hill, the system will gradually reduce the braking force and the vehicle starts running smoothly. If the vehicle fails to start running in 2s, or the driving force applied by the driver is insufficient, the pressure of the brake system is released automatically and the vehicle may start sliding a slope. At the time, you can depress the brake pedal to make the vehicle come to a complete stop, and the system will still help you to conduct the next start (when conditions are met).

Conditions for the HHC system to function:

1. No fault exists on the system, and the engine has been operating;

2. The vehicle is motionless and the brake pedal is depressed;
3. The system detects that the gradient value is met. (In theory, when the slope is  $> 4\%$ , the vehicle will nod during braking, and the nodding angle will offset the slope. As a result, the system may fail to be started on a ramp whose slope is  $> 4\%$ .)
4. When the vehicle is reversed onto a slope, it is necessary to set to the reverse gear firstly.

### Warnings

**The HHC function may fail to prevent the vehicle from sliding a slope on a very slippery or steep hillside.**

**Only as one driver-assistance measure, the HHC function cannot supersede the parking brake function.**

**Always conduct the parking brake when getting out of the vehicle. If there is no sufficient driving force provided after the brake pedal is released, the vehicle will slide backwards. In this case, please immediately draw back the parking brake and depress the brake pedal.**

**If the engine flames out during the process, please immediately draw back the parking brake and depress the brake pedal.**

## Parking Brake

### Mechanical Hand Brake\*

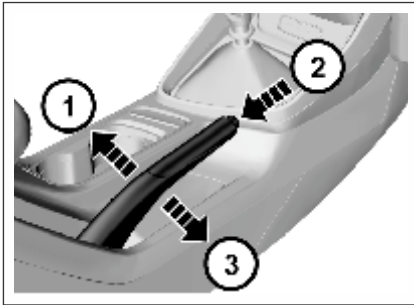

The parking brake impacts rear wheels.

The parking brake lever is between two front-row seats.

If you are to use the parking brake, you should stop the vehicle, depress the brake pedal and tension the parking brake lever.

When you are to release the parking brake, depress the brake pedal and take the following measures:

1. Draw back the parking brake lever slightly.
2. Press the button on the parking brake lever joint.
3. Release the parking brake lever when holding the button pressed.

When parking on a downhill or uphill pavement, tension the parking brake as tightly as possible.

- When parking the vehicle on one uphill ramp, turn the front wheels away from the road shoulder.
- When parking the vehicle on one downhill ramp, turn the front wheels towards the road shoulder.

Vehicle equipped with a manual transmission:

1. Turn the gear lever to the neutral gear when parking the vehicle on the horizontal ground.
2. Turn the gear lever to the reverse (R) gear when parking the vehicle towards the downhill direction.
3. Turn the gear lever to Gear I (turn the automatic transmission to Gear D) when parking the vehicle towards Gear D).

When parking one automatic model with dual clutch transmission, engage Gear P on all pavements.

### Caution

**If the parking brake is not engaged correctly, the vehicle may move automatically due to out-of-control in some cases (such as in case of parking on a ramp) and thus a danger may be caused.**

**When necessary, please have the MG Authorised Service Center adjust.**

### Note

**Do not drive the vehicle with the parking brake not released; otherwise the rear wheel brake may get overheated or be subject to premature wear. As a result, you must replace the rear wheel brake; otherwise, other components of the vehicle may get damaged.**

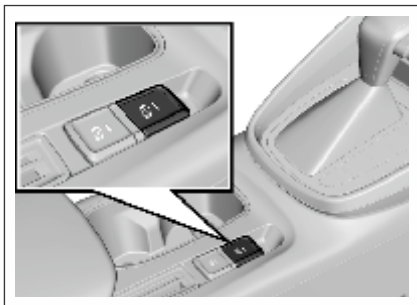
**Electronic Parking Brake (EPB) \***

The parking brake impacts rear wheels.

As shown in the figure above, the EPB switch is between two front-row seats.

**Manually Apply Parking Brake**

If you have to apply parking brake, depress the brake pedal to stop the vehicle and then draw back the electronic parking brake switch. In this case, the EPB working indicator illuminates, and you release the EPB switch after the instrument cluster displays “Parking brake applied”.

At the time, the EPB system brake will be clamped to park the vehicle in situ.

**Note**

**In the process of applying or releasing the parking brake, it is normal that you will feel that the brake pedal lifts or lowers.**

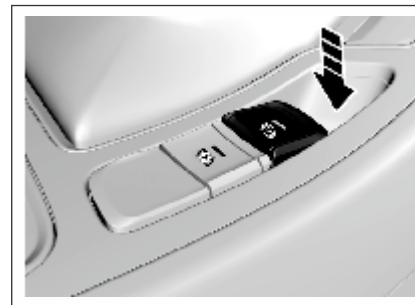
**Manually Release Parking Brake**

If you have to release parking brake, firstly confirm that the ignition switch is at the ON position, depress the brake pedal, and then press the EPB switch. The EPB working indicator  $\textcircled{P}$  goes out, and the instrument cluster displays “parking brake released”, reminding you of parking brake released.

If the brake pedal has not been depressed, the instrument will give a hint “Please depress the brake pedal and then release the EPB switch”.

When you are operating the EPB switch, the switch will make response only when the time for releasing or pressing the switch is  $> 0.1$  s.



**EPB Automatic Clamping Function**

When the engine flames out in the motionless state, the vehicle will automatically apply parking brake, and you do not have to pull up the EPB switch.

**EPB Automatic Releasing Function**

You do not have to manually release parking brake when starting the vehicle; parking brake will be released automatically when the system detects that the vehicle is going to start.

Start the vehicle, engage gear (drive gear or reverse gear), and the driver's safety belt is tightened; depress the accelerator and release the clutch. After the vehicle start conditions are met, the parking brake will be released automatically.

To smoothly start and avoid sliding backwards on an uphill pavement, opening of the accelerator being depressed shall be enlarged properly.

**Anti-sliding Reclamping Function**

When the parking brake is in the clamped state, if it is detected that wheels roll, EPB will immediately reclamp to avoid sliding.

**EPB Hot Disc Reclamping Function**

If you park when the rear brake disc temperature is high, the braking force may reduce after a period of time due to thermal expansion and cold contraction. EPB can keep the braking force by reclamping many times to avoid sliding.

**EPB Dynamic Braking Function**

During driving (speed > 3 km/h), continuously draw back the EPB switch to trigger the ESC system so as to brake four wheels till the vehicle comes to a stop. EPB clamps after the vehicle stops. If the EPB switch is released halfway, braking is released.

In case of dynamic braking, if the ESC system is subject to braking failure, EPB clamps rear wheels to brake.

This function can be activated only in case of emergencies such as foot brake failure. Please neither activate the function in normal times nor have others operate the EPB switch without permission.

**Detection Line Passing Mode**

Conduct as required by the detection line after entering the roller platform. Continuously draw back the EPB switch or

continuously conduct the action of drawing back-releasing the EPB switch 6 times.

**Deactivation of Automatic Clamping Function**

During transport, traction and vehicle cleaning, you may need deactivate the EPB automatic clamping function so as to make it possible to move the vehicle after flameout.

Deactivation method: Depress the brake pedal and hold the EPB switch pressed while killing the engine. Try to move the vehicle to confirm that EPB is not in the clamped state. Afterwards, if you have to apply the parking brake, draw back the EPB switch.

Deactivate the automatic clamping function only on the flat ground. Otherwise, the vehicle will move and thus a danger may be caused when the foot brake is released.

After deactivating the automatic clamping function, take measures to prevent from sliding due to lack of braking force, for example, cushion wood blocks or stones on both sides of a wheel.

**Note**

If the battery is excessively low, EPB will fail to be applied or released normally. If the condition above exists, please charge the battery. We recommend you contact the MG Authorised Service Center for solution.

**Note**

Specialized equipment and technologies are required for EPB brake lining replacement. Please do not have it repaired by yourself or at a maintenance shop rather than the Service Center. Otherwise, the EPB system may get damaged. If the EPB system components have been overhauled, they are not warranted for maintenance.

**Automatic Vehicle Hold (AVH)\***

The vehicle provided with EPB has the AVH function.

The driver depresses the brake pedal to stop the vehicle after the function is activated, or the driver depresses the brake pedal when the vehicle is motionless and the engine idles. After the brake pedal is released, the hydraulic pressure in the brake system will be kept to park

the vehicle in situ (whether on a downhill or uphill pavement or on flat ground), at the time there is no need to draw back EPB to park.

If the driver depresses the accelerator and releases the clutch to start the vehicle within 5 min, the hydraulic pressure in the brake system will be automatically released and the parking will be released, so as to start the vehicle. 5 min later, it will automatically switch to the EPB caliper to clamp and park, and the hydraulic pressure in the brake system will be released. Start and shutdown of AVH can be memorized. If AVH is in the on / off state when the power is off last time, AVH keeps in the corresponding state when the power is on next time.

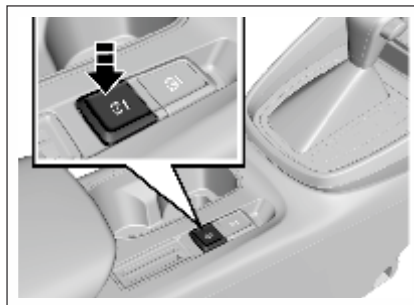
**Automatic Vehicle Hold (AVH) Switch\***

When the engine has been in operation, the driver's safety belt is tightened, and the driver's side door has been closed, you have to press the AVH switch, and the background lamp on the switch illuminates to activate the AVH function.

Afterwards, if following conditions are met, the AVH working indicator on the instrument illuminates. The parking brake will function and the brake system applies the braking force to park the vehicle in situ.

AVH Conditions (AVH Function Activated Firstly):

1. The vehicle is motionless and the engine is running.
2. The brake pedal is depressed to a degree (brake hydraulic pressure > 4 bar).
3. The driver's seat belt is buckled and the driver's side door is closed.

**Other Conditions (They Shall be Satisfied Simultaneously):**

1. No fault exists on the system.
2. EPB has been released.

3. The accelerator pedal has not been depressed (opening < 2%).

### How to Manually Release Automatic Parking Brake After AVH?

Confirm that the ignition switch is at the ON position, depress the brake pedal, and press the EPB switch. The AVH working indicator goes out and the automatic parking brake is released.

### Automatic Release After AVH

You do not have to manually press the EPB switch to release when starting the vehicle next time after AVH. Automatic release will be done when the system detects that you are going to start the vehicle.

Operate the engine, engage gear (drive gear or reverse gear), and the driver's safety belt is tightened and the driver's side door has been closed. Depress the accelerator and release the clutch. After the vehicle start conditions are met, the parking brake will be released automatically.

## Fuel

### Fuel Suggestions

Fill GB 91# gasoline for vehicle or gasoline with the equivalent standard No., or gasoline with a higher standard No. Using the fuel with an extremely low octane value will reduce power and torque of the engine, and increase the consumed fuel volume.

### Do not Use Methyl Alcohol

Do not use the fuel containing methyl alcohol on the vehicle. This fuel will reduce the vehicle performance and damage the fuel system components.

### Driving in Other Countries

When driving your vehicle in other countries:

- Please follow all registration and insurance regulations.
- Confirm that the country can provide proper fuel.

### Caution

**If you use any incorrect fuel, the engine and the catalytic converter will get seriously damaged. Always use the fuel suitable for your vehicle.**

**For the purpose of safety, the fuel tank, pump and pipe must be grounded correctly. The static electricity will ignite vapor included in the gasoline. You will get burnt and the vehicle will get damaged.**

### Dangers

**The fuel is one of flammables or explosives.**

**Smoking is prohibited. Keep away from open flames, sparks and smoking materials. If gasoline catches fire, serious burns will be caused and your vehicle will get damaged.**

**If you smell fuel odors, please immediately ask MG Authorized Service Center to repair according to the fault cause.**

**Caution**

Using the fuel with an extremely low octane value will lead to uncontrolled burning and cause the engine to be damaged. Using the fuel containing methyl alcohol is not allowed for the vehicle design. Therefore, do not use the fuel containing methyl alcohol. As the methyl alcohol will corrode the metal parts in the fuel system and damage the plastic and rubber parts. The damage caused due to use of the fuel containing methyl alcohol is beyond the warranty scope. If contents of manganese and iron exceed the standard, the three-way catalytic converter may be blocked, and the spark plug misfires, etc. Therefore, please use the gasoline meeting requirements of the national standard.

**Dangers**

Shut down the engine and any heating devices provided outside the combustion chamber before refueling. Turn off all mobile phones.

Follow operation and safety instructions of gasoline station when refueling.

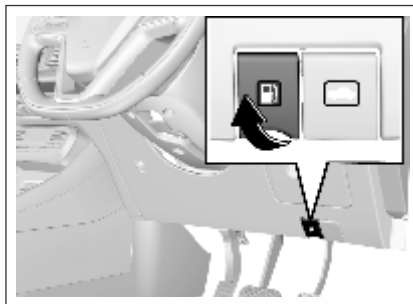
**Fuel Filling**

1. Stop the engine from running.
2. Pull up the filler flap release handle at the left lower side of the instrument panel to open the filler flap.

**Warnings**

**If you fail to open the filler flap in the cold weather, you can gently tap the filler flap. Then, try again.**

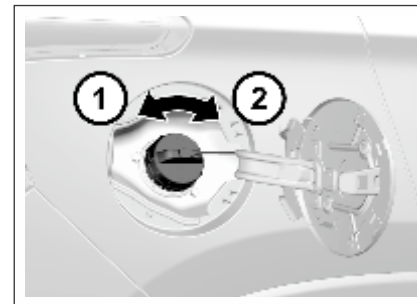

3. Slowly turn the filler cap anticlockwise. If you hear the hissing sound, wait till the sound stops, and then unscrew the cap.
4. Unscrew the filler cap. The filler cap is connected to the filler flap with a sling. Hang the sling to the hanger on the filler flap to secure the filler cap.
5. Reinstall the filler cap after refueling. Turn the filler cap clockwise till clicks are heard.
6. Tightly close the filler flap.

## Vehicle Service & Maintenance

<b>General Information.....</b>	<b>158</b>		
• Accessories and Vehicle Retrofitting.....	158		
• Vehicle Storage.....	158		
<b>Driver Checklist .....</b>	<b>158</b>		
• Exterior .....	158		
• Interior .....	158		
<b>Engine Compartment.....</b>	<b>159</b>		
• 1.5T Engine .....	159		
• 2.0 Diesel Engine .....	160		
<b>Engine Oil .....</b>	<b>161</b>		
• Engine Oil Level Check.....	161		
• Engine Oil and Oil Filter Replacement.....	161		
<b>Coolant .....</b>	<b>162</b>		
<b>Brake and Clutch Fluid.....</b>	<b>163</b>		
• Brake / Clutch Fluid Adding.....	163		
• Auto Transmission Clutch Fluid Adding *.....	164		
<b>Transmission Fluid.....</b>	<b>165</b>		
• Transmission Fluid Leakage Check....	165		
<b>Windshield Washer Solvent.....</b>	<b>165</b>		
		<b>Diesel Exhaust Fluid (DEF).....</b>	<b>166</b>
		<b>Windshield Wiper.....</b>	<b>172</b>
		<b>Air Filter .....</b>	<b>173</b>
		• Air Filter Cleaning.....	173
		<b>Drive Belt.....</b>	<b>173</b>
		<b>Brake Pedal .....</b>	<b>173</b>
		• Brake Pedal Travel Check.....	173
		<b>Fuse .....</b>	<b>174</b>
		• Engine Compartment Fuse Box.....	174
		• Indoor Fuse Box Layout.....	175
		• Engine Compartment Fuse Box Layout.....	176
		<b>Lamp Bulb Replacement.....</b>	<b>177</b>
		<b>Wheels and Tyres.....</b>	<b>178</b>
		• Maintenance .....	178
		• Internal Tread Wear Indicator .....	179
		• Tyre Rotation.....	180
		• Winter Tyres.....	180
		• Tyre Chain.....	180
		<b>Spare Tyre, Jack and Tools.....</b>	<b>181</b>
		• Tool Kit.....	181
		• Spare Tyre .....	181
		• Jack Lifting Point.....	181
		• Tyre Replacement.....	182
		<b>Jump Start (Dead Battery) .....</b>	<b>184</b>
		<b>Vehicle Traction.....</b>	<b>186</b>
		• Emergency Trailer.....	187
		• Front Towing Hook .....	187
		• Rear Towing Hook .....	188
		<b>Getting Vehicle Out of Trap.....</b>	<b>189</b>
		<b>Vehicle Maintenance.....</b>	<b>189</b>
		• Cleaning Agent .....	189
		• Vehicle Interior Maintenance and Cleaning.....	190
		• Glass Surface .....	190
		• Vehicle Exterior Maintenance and Cleaning .....	191
		• Corrosion Prevention .....	192

## General Information

### Accessories and Vehicle Retrofitting

**Do not slide in case that the engine is out of operation.**

We recommend using original spare and accessory parts and parts and components that are approved by the company to be particularly suitable for the vehicle. We may not be able to guarantee the compatibility of other products with this vehicle, even if these products meet the specified requirements or are otherwise approved.

### Tips for Glass Filming

During the process of glass filming, the cleaning solution may easily enter electronic components around the instrument panel, causing electrical faults. Please complete waterproofing work before filming.

### Caution

**Do not retrofit the vehicle. Otherwise, the performance, durability and safety of the vehicle may be affected; problems caused by retrofitting are not within the scope of warranty.**

### Vehicle Storage

#### Long-term Storage

Several months of storage of the vehicle:

- Clean the vehicle for waxing.
- Check the wax coating of engine compartment and the underbody.
- Clean and protect the rubber seal.
- Replace the engine oil.
- Drain the washer fluid reservoir.
- Check coolant antifreezing agent and corrosion protection.
- Adjust the tyre pressure according to the specified value under full load.
- Park the vehicle in a dry and well-ventilated area. Shift to Gear I or reverse gear to prevent the vehicle from sliding.
- Close all doors and lock the vehicle.
- Disconnect the clip from the vehicle battery negative terminal. Pay attention to that all systems are out of service at this time, e.g. theft deterrent system.

#### Vehicle being Put into Operation again:

- Connect the clip to the vehicle battery negative terminal. Enable the electronic device of power window.
- Check the tyre pressure.
- Fill the washer fluid reservoir.
- Check the engine oil level.
- Check the coolant level.

### Driver Checklist

Check the interior, exterior and engine compartment regularly to keep the vehicle safe and reliable.

#### Exterior

##### Tyre

- Inflate tyres correctly. (Refer to “Wheels and tyres” in this chapter).
- There is no crack on tyre wall or tyre tread.
- There is no foreign matter in tread pattern.

##### Lamp

- It includes all driving lamps, headlamps, tail lamps, turn signal lamps, brake lamps and fog lamps.

##### Oil Tank

- Check whether the level of fluid containers under engine hood is appropriate.

##### Windshield Wiper

- Check the state of wiper arms and blades.

#### Interior

##### Steering

- Check whether the steering wheel is too loose (free travel).

## Engine Compartment

### 1.5T Engine

#### Parking Brake

- Ensure the travel of parking brake lever is appropriate.

#### Instrument Panel

- Check whether all instruments, control buttons and warning lamps are functioning normally.

#### Rearview Mirror

- Ensure the reflecting surface of rearview mirror is in good state and clean.
- Check whether all rearview mirrors can be readjusted.

#### Control

- Check the brake pedal and clutch pedal for appropriate travel.

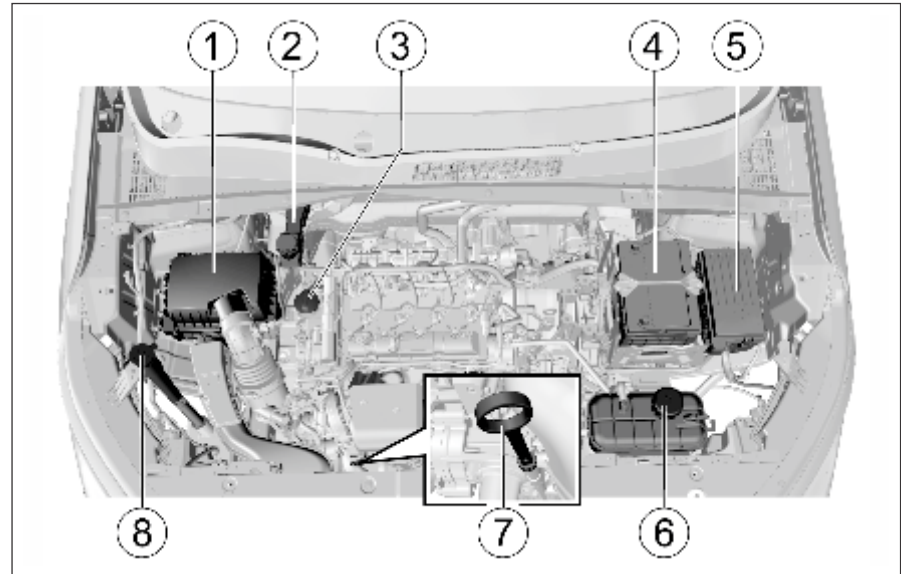

1. Air filter
2. Brake/clutch fluid reservoir
3. Engine oil filler cap
4. Battery

5. Fuse and relay box
6. Coolant pot
7. Engine oil dipstick
8. Windshield washer solvent container

## 2.0 Diesel Engine

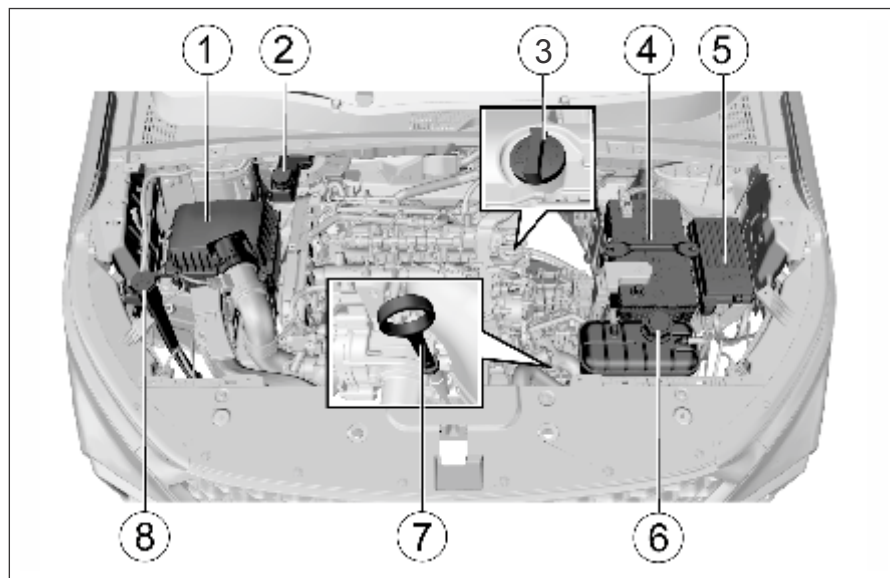

1. Air filter
2. Brake/clutch fluid reservoir
3. Engine oil filler cap
4. Battery
5. Fuse and relay box
6. Coolant pot
7. Engine oil dipstick
8. Windshield washer solvent container



## Engine Oil

Maintain the engine oil at a proper level to ensure correct lubrication of engine.

It is normal that the engine consumes some oil.

Check the engine oil level regularly, e.g. every time parking for refueling.

If the engine oil pressure warning lamp located inside instrument panel is ON, check the engine oil level immediately.

### Engine Oil Level Check

1. Park the vehicle on a horizontal ground.
2. After the engine stops running, wait for a few minutes to have the oil back to the oil pan. For cold engine, the time for the oil returning to the oil pan will be relatively long.
3. Pull out the oil dipstick and clean it.
4. Insert the oil dipstick completely.
5. Pull out the oil dipstick again.
6. Check the engine oil on the dipstick to ensure that the oil is free of contamination.

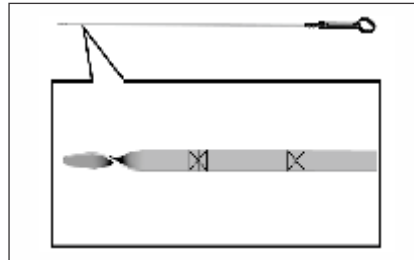

7. Observe the oil level via the oil dipstick. The oil level should be between the lower limit and the upper limit.
8. If the oil level is lower than the lower limit, add engine oil of the same grade to have the oil level approaching to but not higher than the upper limit. The engine oil filler cap is on the cylinder head cover. Refer to the diagram of “Engine Compartment”.

### Caution

**Engine oil is irritating and can cause illness or fatal danger in case of swallowing.**

- Keep it out of reach of children.
- Avoid repeated or prolonged skin contact with engine oil.
- Wash the part in contact with engine oil with soap water or hand sanitizer.

### Note

**Prohibit the engine oil level from being higher than the upper limit mark on the oil dipstick. Excessive engine oil may have adverse effect on the engine, including:**

- Increased engine oil consumption.
- Oil spilling of spark plug.
- A large amount of carbon deposits accumulated on the engine.

### Engine Oil and Oil Filter Replacement

The engine oil will lose the lubricating capacity after being contaminated. Be sure to replace the engine oil in accordance with maintenance procedures. The oil filter must be replaced at the same time of engine oil replacement every time. Under harsh conditions, the replacement interval of engine oil and oil filter must be shorter than the interval specified in standard maintenance procedures.

### Caution

**This work requires professional skills, tools and equipment; therefore, please go to the MG Authorised Service Center for help. Otherwise, it may cause personal injury or damage to the vehicle.**

Harsh conditions include but not limited to:

- Frequent cold start.
- Frequent starting and stopping in case of traffic jam.
- Frequent driving for short trips.
- Frequent driving at an outside temperature of below 0 °C.
- Long time idling.
- Frequent driving at low speed.
- Frequent driving under dusty conditions.

### Caution

**The engine oil and oil drum are harmful to human health.**

**Avoid repeated or prolonged exposure to engine oil. In case of contact with engine oil, wash the skin with soap water or hand sanitizer. Keep this kind of toxic substance out of reach of children.**

**Engine oil is irritating to the skin and can cause illness or fatal danger in case of swallowing.**

### Note

**It is prohibited to dispose of old engine oil and filters together with household garbage.**

**It shall make use of local legal waste management facilities.**

**Old engine oil and filters contain harmful substances that are harmful to human health and threaten the environment.**

### Note

**The use of non-specified or poor quality engine oil or additives will cause damage to the engine. Please consult the MG Authorised Service Center before attempting to use additives.**

## Coolant

The vehicle cooling system is filled with ethylene glycol coolant.

This kind of coolant in right mixing ratio can provide excellent anti-corrosion and antifreezing performance for the cooling and heating systems.

When the engine is in a cold state, the coolant level shall be between MIN (minimum) and MAX (maximum) marked on the coolant tank. The coolant level rises with the engine temperature rise and drops as the engine cools.

If the coolant level is lower than the MIN (minimum) mark, please go to the MG Authorised Service Center for coolant filling or replacement.

### Note

**Ordinary water or coolant in wrong mixing ratio will cause damage to the cooling system.**

**It is prohibited to use ordinary water, alcohol or methanol on the vehicle to prevent freezing.**

## Brake and Clutch Fluid

### Note

**Under pressure, hot coolant and steam may spray out, causing serious personal injury.**

**It is prohibited to open the coolant tank cover before the engine and radiator cool down.**

### Caution

**The coolant is a dangerous substance.**

- **Avoid repeated or prolonged exposure to coolant.**
- **In case of contact with coolant, wash the skin and fingernail with soap water.**
- **Keep it out of reach of children.**
- **Coolant is irritating to the skin and can cause illness or fatal danger in case of swallowing.**

There is a brake and clutch fluid reservoir on the vehicle. The brake and clutch fluid is moisture-absorbing, and the fluid with excessive water content will reduce the efficiency of the hydraulic brake/clutch system. Replace the fluid as per the instruction in the Manual to avoid corrosion of the hydraulic system.

Be sure to use the brake/clutch fluid recommended by MG Motor. Add fluid into the reservoir to reach a proper level. The fluid level shall not be lower than the MIN (minimum) mark or higher than the MAX (maximum) mark.

The cause of excessive low brake fluid level may be leakage of brake system or normal wear of brake pad/lining. Please contact the MG Authorised Service Center to ensure that whether the system needs to be repaired. If repairs are necessary, add fluid after repair of hydraulic braking system. When the brake fluid level is lower than the lower limit, the braking system warning lamp “ ” will be on. Refer to “Braking System/EBD Warning Lamp” in Chapter “Instrument and Control Device”.

### Brake / Clutch Fluid Adding

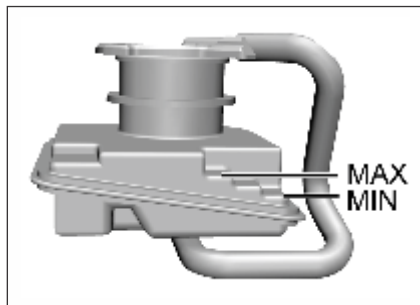

1. Thoroughly wipe off the dirt around the reservoir filler cap.
2. Open the filler cap.
3. Add the brake/clutch fluid recommended by MG Motor to reach the MAX (maximum) mark. Be careful not to spill the fluid on the paint surface. In case of spilling on the paint surface, wash the area with cold water immediately.
4. Re-install the reservoir filler cap.

**Auto Transmission Clutch Fluid Adding \***

The vehicle equipped with auto transmission has an independent clutch fluid reservoir.

1. Thoroughly wipe off the dirt around the reservoir filler cap.
2. Open the filler cap.
3. Add the clutch fluid recommended by MG Motor to reach the MAX (maximum) mark. Be careful not to spill the fluid outside the reservoir. In case of spilling on the paint surface, wash the area with cold water immediately.
4. Re-install the reservoir filler cap.

The level inspection and adding of clutch fluid require skills, and the fluid replacement requires specialized skills and equipment. It is recommended to go to a service center for vehicle maintenance on time. For any help, please contact the service center.

**Note**

**Before opening the filler cap, clean the area around the brake / clutch fluid reservoir filler cap.**

**Contamination of the brake/clutch fluid system will affect the system performance, resulting in costly repairs.**

**Caution**

**The brake / clutch fluid is irritating to the skin and eyes.**

**Keep the skin or eyes from contact with the brake/clutch fluid. In case of contact, wash the part in contact with the brake/clutch fluid with soap water or hand sanitizer thoroughly.**

**Caution**

**It is prohibited to dispose of the old brake/clutch fluid as household garbage. It shall make use of local legal waste management organization.**

**The old brake/clutch fluid and containers are dangerous and may be harmful to human health and the environment.**

**Caution**

**The brake/clutch fluid spilling over the engine may cause a fire.**

**An overfull fluid reservoir is not allowed. Engine fire may cause personal injury and damage the vehicle and other properties.**

## Transmission Fluid

### Transmission Fluid Leakage Check

This work requires professional skills and equipment. To avoid personal injury or vehicle damage, it is suggested to go to the MG Authorised Service Center for help.

## Windshield Washer Solvent

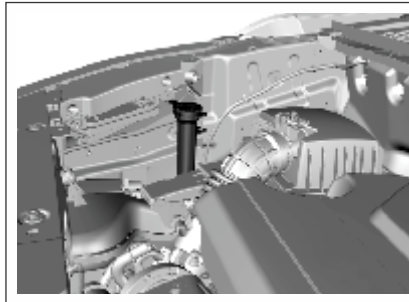

Before driving, be sure that the fluid reservoir contains sufficient specified washer solvent.

In cold weather, the windshield washer solvent container cannot be overfilled.

Washer solvent will swell under low temperature due to freezing. An overfull container has no enough space for expansion, thus resulting in damages.

### Note

Please go to the **MG Authorised Service Center** for filling of the correct washer solvent.

**Do not fill water or radiator antifreezing agent into the windshield washer solvent container. The water will lead the solution to freeze, and the frozen solution will damage the windshield washing system. The radiator antifreezing agent will damage the windshield washing system and vehicle paint.**

### Note

**Add windshield washer solvent:**

**It is suggested to use the ready-to-use special washer solvent. If concentrated washer solvent is used, please add water to dilute it according to the manufacturer's instructions.**

**Do not use tap water. Minerals or impurities contained in tap water may block lines of the windshield washer.**

**If the temperature is likely to fall below freezing point, use windshield washer solvent with good antifreezing performance.**

## Diesel Exhaust Fluid (DEF)

### Diesel Exhaust Fluid (DEF) Injection System Failure Warning Light - If Equipped

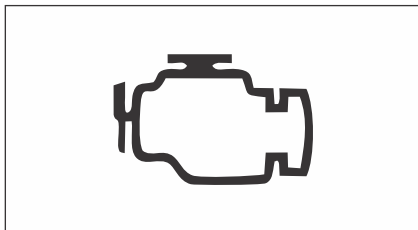

This warning light will illuminate along with a dedicated message on the display (If Equipped) if an unknown fluid not conforming with acceptable characteristics is inserted, or if an average consumption of Diesel Exhaust Fluid (DEF) over 50% is detected. Contact an authorized dealer as soon as possible.

If the problem is not solved, a specific message will appear on the Instrument Cluster Display whenever a certain threshold is reached until it will no longer be possible to start the engine.

When about 200 km are remaining before the Diesel Exhaust Fluid (DEF) tank is empty, a continuous dedicated message will appear on the instrument panel, accompanied by a buzzer sound\* (If Equipped).

### Low Diesel Emissions Additive Diesel Exhaust Fluid (DEF) Indicator Light - If Equipped



The Low Diesel Exhaust Emissions Additive Diesel Exhaust Fluid (DEF) indicator light illuminates when the Diesel Exhaust Fluid (DEF) level is low.

Fill the Diesel Exhaust Fluid (DEF) tank as soon as possible with at least 5 liters of Diesel Exhaust Fluid (DEF).

\*The exact message on instrument cluster may vary.

MESSAGE	DESCRIPTION
<b>Diesel Emissions Additive Diesel Exhaust Fluid (DEF) Warning Messages:</b>	
Low Diesel Emissions Additive Diesel Exhaust Fluid (DEF) Level Warning	<p>The first low level warning will be given at around 2,400 km range, and is determined according to the current consumption rate. The "Diesel Exhaust Fluid (DEF) Low Level" warning light and message will display on the instrument panel. The Diesel Exhaust Fluid (DEF) low level warning light will remain lit until the Diesel Exhaust Fluid (DEF) tank is topped up with at least 5 Liters of Diesel Exhaust Fluid (DEF). If the level is not resolved an additional warning appear whenever a certain threshold is reached until it will no longer be possible to start the engine.</p> <p>When 200 km are remaining before the Diesel Exhaust Fluid (DEF) tank is empty, a message will appear on the instrument panel, accompanied by a buzzer sound. When the range is at 0, the display will show a dedicated message (if equipped). In this case, the engine will not restart. It will be possible to restart the engine again as soon as Diesel Exhaust Fluid (DEF) is added; the minimum amount required is 5 Liters. Fill the Diesel Exhaust Fluid (DEF) tank as soon as possible with at least 5 Liters of Diesel Exhaust Fluid (DEF).</p> <p><b>NOTE:</b></p> <p>When the Diesel Exhaust Fluid (DEF) tank is empty, and the vehicle is stopped it is no longer possible to restart the vehicle until a minimum of 5 Liters of Diesel Exhaust Fluid (DEF) is added to the Diesel Exhaust Fluid (DEF) tank.</p>

\*The exact message on instrument cluster may vary.

MESSAGE	DESCRIPTION
<b>Diesel Emissions Additive Diesel Exhaust Fluid (DEF) Fault Warning Messages:</b>	
<p>Engine Will Not Restart Service Diesel Exhaust Fluid (DEF) System See Dealer</p>	<p>This message will display if Diesel Exhaust Fluid (DEF) system issue detected is not serviced during the allowed period. Your engine will not restart unless your vehicle is serviced by an authorized dealer. If the level is not resolved, an additional warning appear whenever a certain threshold is reached until it will no longer be possible to start the engine. When 200 km are remaining before the Diesel Exhaust Fluid (DEF) tank is empty, a message will appear on the instrument panel accompanied by a buzzer sound.</p>

\*The exact message on instrument cluster may vary.

### Note

- **The display may take up to five seconds to update after adding 7.5 Liters or more of Diesel Exhaust Fluid (DEF) to the Diesel Exhaust Fluid (DEF) tank. If you have a fault related to the Diesel Exhaust Fluid (DEF) system, the display may not update to the new level. See an authorized dealer for service.**
- **Diesel Exhaust Fluid (DEF) freezes at temperatures lower than 12°F (-11°C). If the car stands for a long time at this temperature, refilling could be difficult. For this reason, it is advised to park the vehicle in a garage and / or heated environment, and wait for the Diesel Exhaust Fluid (DEF) to return to liquid state before topping up.**



## Adding Diesel Exhaust Fluid (DEF)

### Preliminary Conditions

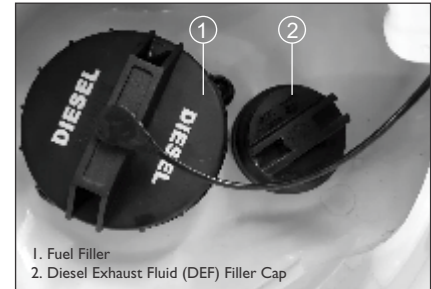

Consumption of the additive Diesel Exhaust Fluid (DEF) depends on the condition of vehicle use and is indicated by the Warning Light and / or the message on the instrument panel.

Diesel Exhaust Fluid (DEF) freezes at temperatures lower than 12°F (-11°C). If the car stands for a long time at this temperature refilling could be difficult. For this reason, it is advised to park the vehicle in a garage and / or heated environment and wait for the Diesel Exhaust Fluid (DEF) to return to liquid state before topping up.

Proceed as follows:

- Park the car on flat ground and stop the engine by placing the ignition in the OFF position.

### Diesel Exhaust Fluid (DEF) - If Equipped

The vehicle is equipped with an Diesel Exhaust Fluid (DEF) injection system and Selective Catalytic Reduction to meet emission standards. These two systems ensure compliance with the diesel emissions requirements; at the same time, they ensure fuel-efficiency, handling, torque and power. For messages and system warnings, refer to the "Warning Lights And Messages" in the "Getting To Know Your Instrument Panel" section. Diesel Exhaust Fluid (DEF) is a very stable product with a long shelf life. Stored at temperatures LOWER than 90°F (32°C), it has a shelf life of at least one year. For more information on the Diesel Exhaust Fluid (DEF) liquid type, see the "Fluids and lubricants" in the "Technical specifications" section.

#### NOTE:

Diesel Exhaust Fluid (DEF) freezes at temperatures lower than 12°F (-11°C).

### Diesel Exhaust Fluid (DEF) Storage

Diesel Exhaust Fluid (DEF) is considered a very stable product with a long shelf life. If Diesel Exhaust Fluid (DEF) is kept in temperatures between 10° and 90°F (-12° and 32°C), it will last a minimum of one year.

Diesel Exhaust Fluid (DEF) is subject to freezing at the lowest temperatures. For example, Diesel Exhaust Fluid (DEF) may freeze at temperatures at or below 12°F (-11°C). The system has been designed to operate in this environment.

#### NOTE:

When working with Diesel Exhaust Fluid (DEF), it is important to know that:

- Any containers or parts that come into contact with Diesel Exhaust Fluid (DEF) must be Diesel Exhaust Fluid (DEF) compatible (plastic or stainless steel). Copper, brass, aluminum, iron or non-stainless steel should be avoided as they are subject to corrosion by Diesel Exhaust Fluid (DEF).
- If Diesel Exhaust Fluid (DEF) is spilled, it should be wiped up completely.

- Open the fuel door, remove the Diesel Exhaust Fluid (DEF) filler cap.

### Caution

Never fill Diesel Exhaust Fluid (DEF) or diesel fuel into the wrong filling ports. This may result serious damage to Engine, Fuel system and Emission system components. In case of wrongly filled do not start the engine, contact an authorized dealer.

### Note

#### At Each Stop for Fuel

Check the engine oil level about five minutes after a fully warmed engine is shut off. Checking the oil level while the vehicle is on level ground will impose the accuracy of the oil level reading.

- Check the windshield washer solvent and add if required.
- Check and top-up Diesel Exhaust Fluid (DEF) if required as indicated by the Warning Light and/or message on the instrument cluster.

### Note

It is recommended to visit the MG Authorised workshop for refill / top up.

### Refilling With Nozzles

You can fill up at any Diesel Exhaust Fluid (DEF) distributor.

Proceed as follows:

- Insert the Diesel Exhaust Fluid (DEF) nozzle in the filler, start refilling and stop refilling at the first shut-off (the shut-off indicates that the Diesel Exhaust Fluid (DEF) tank is full). Do not proceed with the refilling, to prevent spillage of Diesel Exhaust Fluid (DEF).
- Extract the nozzle.

### Refilling With Containers

Proceed as follows:

- Check the expiration date.
- Read the advice for use on the label before pouring the content of the bottle into the Diesel Exhaust Fluid (DEF) tank.
- If systems which cannot be screwed in (e.g. tanks) are used for refilling, after the indication appears on the instrument panel display refer to "Warning lights And Messages" in the "Getting To Know Your Instrument Panel" for further information, fill the Diesel Exhaust Fluid (DEF) tank with no more than 8 liters.

- If containers which can be screwed to the filler are used, the reservoir is full when the Diesel Exhaust Fluid (DEF) level in the container stops pouring out. Do not proceed further.

### Operations After Refilling

Proceed as follows:

- Fit the cap back on the Diesel Exhaust Fluid (DEF) filler by turning it clockwise and screwing it completely.
- Place the ignition to ON POSITION (it is not necessary to start the engine).
- Wait for the indication on the instrument panel to switch off before moving the car. The indication may stay on for a few seconds to approximately half a minute. If the engine is started and the car is moved, the indication will remain on for longer. This will not compromise engine operation.
- If the Diesel Exhaust Fluid (DEF) was topped up when the tank was empty, wait for few minutes, until the warning light goes OFF and then start the engine.

**NOTE:**

- If Diesel Exhaust Fluid (DEF) is spilled out of the filler neck, clean up the area well and proceed to filling up again. If the liquid crystallizes, eliminate it with a sponge and warm water.
- **DO NOT EXCEED THE MAXIMUM LEVEL:** this could cause damage to the reservoir. Diesel Exhaust Fluid (DEF) freezes at under 12° F (-11° C). Although the system is designed to operate below the freezing point of the Diesel Exhaust Fluid (DEF), it is advisable not to fill the tank beyond the maximum level because if the Diesel Exhaust Fluid (DEF) freezes the system can be damaged. Follow the instructions in this section.
- If the Diesel Exhaust Fluid (DEF) is spilled on painted surfaces or aluminium, immediately clean the area with water and use absorbent material to collect the fluid that has been spilled on the ground.
- Do not try to start the engine if Diesel Exhaust Fluid (DEF) was accidentally added to the diesel fuel tank, this can result in serious engine damage, contact an authorized dealer.

- Do not add additives or other fluids to Diesel Exhaust Fluid (DEF), doing so could damage the system.
- The use of non-conforming or degraded Diesel Exhaust Fluid (DEF) may lead to indications appearing on the instrument panel display refer to "Warning Lights And Messages" in the "Getting To Know Your Instrument Panel" for further information.
- Never pour Diesel Exhaust Fluid (DEF) into another container; it could be contaminated.
- If the Diesel Exhaust Fluid (DEF) runs out, see refer to "Warning Lights And Messages" in the "Getting To Know Your Instrument Panel" for further information to continue using the car normally.

**Note**

Once the engine is turned off, the Diesel Exhaust Fluid (DEF) pump rotates (a noise can be heard, which is normal) in reverse direction for approx 30 sec and in turn sucks the Diesel Exhaust Fluid (DEF) back into the tank. This prevents Diesel Exhaust Fluid (DEF) sedimentation in the Diesel Exhaust Fluid (DEF) hose and injectors.

## Windshield Wiper

Foreign objects on the windshield and blade will reduce the effectiveness of the wiper. If the blade does not work properly, wipe the windshield and the blade with special or neutral washer solvent. Flush with water thoroughly. If necessary, repeat the above operation. Do not wipe the windshield with corrosive substances or materials that cannot be removed from the glass (e.g. silicone).

The strips have a layer of graphite on the surface for lubrication and protection. It should be protected from excessive wiping and undue polishing.

Do not start the wiper when the windshield surface is dry. Park the vehicle in a cool place as far as possible to prevent exposure to high-temperature, which will accelerate the aging and deformation of strips.

Remove foreign matters such as bird droppings, dust and leaves from the windshield surface before starting the wiper; otherwise, the service life of strips will be reduced.

### Wiper Blade Removal and Installation

Fold the wiper arm on the windshield for operation.

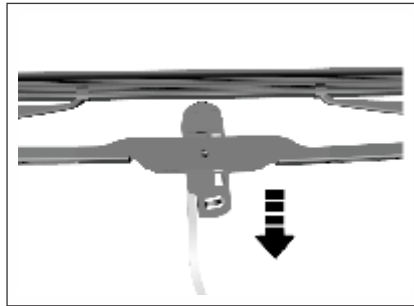

As shown in the figure, firstly press the release switch of the wiper blade in the direction of arrow 1. Then hold the joint part between the wiper blade and the wiper arm with the other hand. Pull the wiper blade down slightly in the direction of arrow 2 to separate the wiper blade from the wiper arm.

During installation, insert and clamp the new wiper blade into the U-slot of the wiper arm.

During the rear wiper blade removal, pull out the wiper blade from the installation point on wiper arm. For installation, align the blade with the installation point and press it into the point.

## Air Filter

Check and replace the air filter element regularly according to the maintenance instructions in the Manual.

### Air Filter Cleaning

If the air filter element is too dirty, clean it according to the following procedures:

1. Shake the air filter element to remove floating dust.
2. Clean the interior of air filter housing.
3. Cover the filter housing with a wet cloth when cleaning the filter element.
4. Clean the filter element with compressed air in the opposite direction of the engine intake.

### Note

**Clean air is necessary for the normal operation of engine.**

**It is prohibited to drive the vehicle without the air filter element being installed. Otherwise, the engine will be damaged.**

## Drive Belt

For normal operation of engine and air compressor, the drive belt should be adjusted to a good state. In case of damage, break or wear, please replace the drive belt.

### Caution

**If the key is not pulled out, the engine may start unintentionally during check. Do not leave the key in the ignition switch when checking the drive belt. Sudden running parts may cause serious personal injury when the engine is in operation.**

## Brake Pedal

### Brake Pedal Travel Check

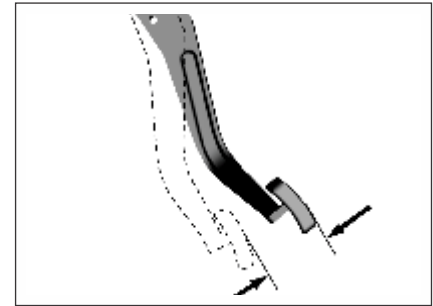

Brake pedal travel:

To avoid affecting the pedal travel, do not lay a thick carpet in the brake pedal area.

The reasonable range of brake pedal free travel is 0~30 mm.

If the brake pedal fails to return or the brake pedal travel becomes longer, please go to the MG Authorised Service Center for inspection. This may indicate faults of the brake system.

## Fuse

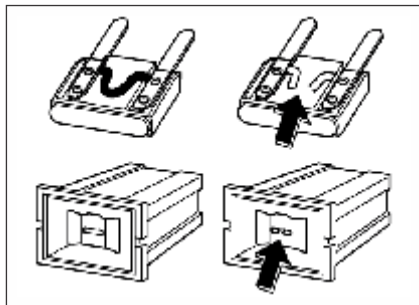

### Fuse replacement:

1. Open the fuse box cover.
2. Identify damaged fuses by finding out blown fuses.
3. Use a fuse extractor to remove the blown fuses. The fuse extractor is in the engine compartment fuse box.
4. Figure out the cause of fusing and remove the fault.
5. Install new fuses with rated current meeting the requirements.

## Indoor Fuse Box



The indoor fuse box is on the lower left side of the instrument panel and it can be seen after pulling out the storage box.

### Caution

**Do not use a conductive tool to remove the blown fuse. The fuse extractor must be used. The use of metal and other electric conductors may cause a short circuit, damage the electrical system or cause a fire, resulting in serious personal injury.**

## Engine Compartment Fuse Box

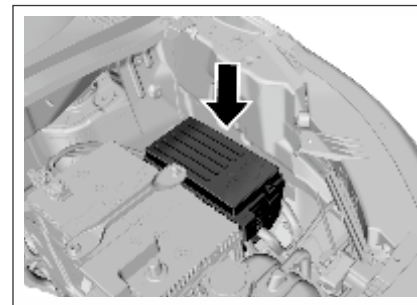

The engine compartment fuse box is next to the battery.

### Caution

**The use of fuse substitutes or the fuse with an incorrect type and current rating may damage the electrical system or cause a fire. Be sure to use a fuse of the type and current rating that meets the requirements. Otherwise, it may cause personal injury and damage the vehicle and other properties.**

### Indoor Fuse Box Layout

For vehicles with different models or configurations, the layout of fuse box internal components may be different. The owner's actual vehicle shall prevail.

NOTES : THE PART OF FUSE RELAY IN THE FUSE BOX IS ADDED AND SUBTRACTED ACCORDING TO THE CONFIGURATION OF THE CAR

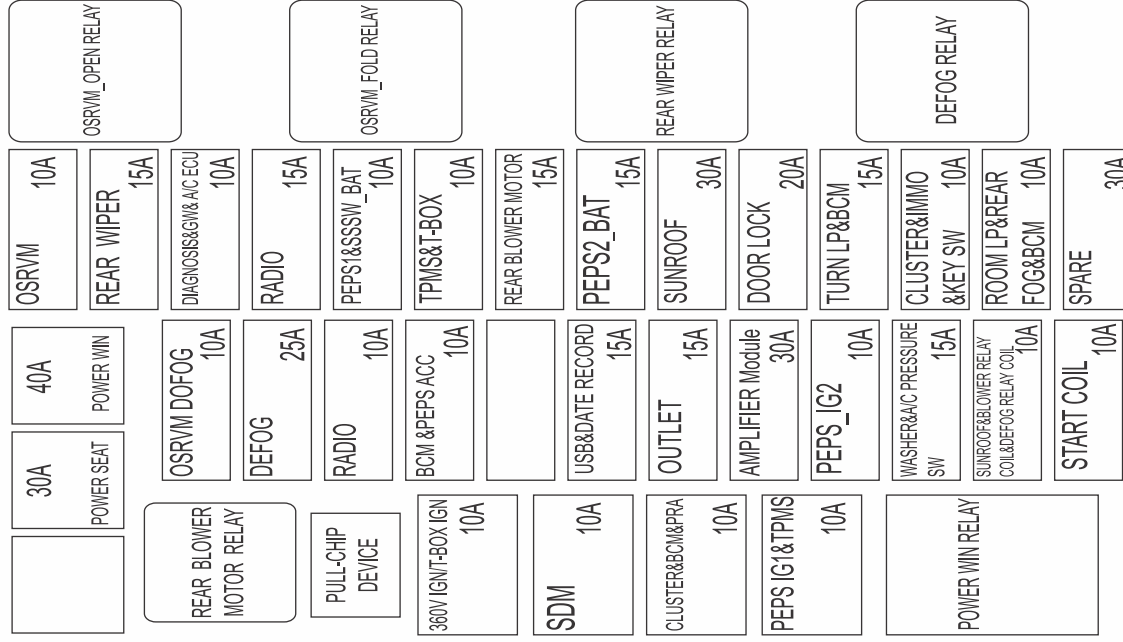

### Engine Compartment Fuse Box Layout

For vehicles with different models or configurations, the layout of fuse box internal components may be different. The owner's actual vehicle shall prevail.

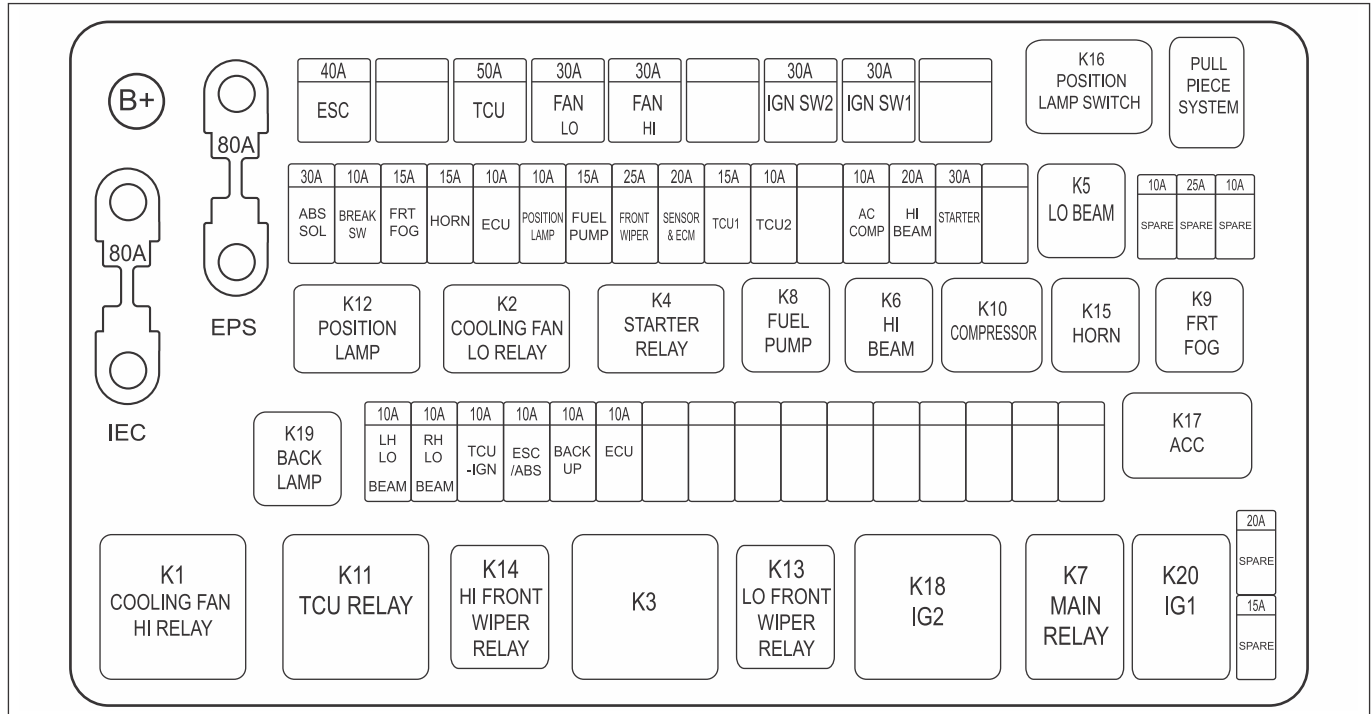



## Lamp Bulb Replacement

### Caution

The gas in the halogen bulb is under pressure. Handle with care and properly dispose of halogen bulbs.

- Wear safety glasses when removing or installing the lamp.
- Take care to prevent bulbs from wear and scratches.
- When the lamp lights up without being packaged, prevent the bulb from contacting liquids.
- Light up the lamp for test after the bulb being installed.
- Replace the cracked or damaged headlamp in time.
- Do not touch the glass portion with ungloved fingers when replacing the halogen bulb.
- Keep the bulb out of reach of children.
- Dispose of the old bulb carefully to prevent personal injury due to bulb explosion.

### Caution

Clean the halogen bulb with alcohol or mineral spirits and non-woven fabrics. Do not touch the bulb with hands directly.

Fingerprints may significantly shorten the effective service life of halogen bulbs.

### Caution

Professional skills and special equipment are required for replacement of bulbs. It is suggested to go to the MG Authorised Service Center for help. Otherwise, it may cause personal injury or damage the vehicle.

## Lamp Fogging

When the temperature is low or the air is humid, there may be water mist inside the lamp. Turn on the lamp, and the water mist will dissipate after a while. If it is resulted from the weather, repair is not necessary.

If the water mist does not dissipate after the lamp is turned on and there is more and more water vapor, please contact the MG Authorised Service Center for inspection.

## Wheels and Tyres

Original tyres guarantee optimum matching of riding comfort, tread life and performance.

### Caution

**Be sure to use wheels and tyres of specified specifications. The use of wheels and / or tyres of other specifications may result in abnormal operation of ABS and other relevant components and even cause collision accidents.**

**Please consult the MG Authorised Service Center before replacing original tyres or wheels.**

**Otherwise, it may cause personal injury and damage the vehicle or other properties.**

### Maintenance

The tyre pressure shall meet provisions of the Manual so as to ensure optimum matching of driving comfort, safety and driveability.

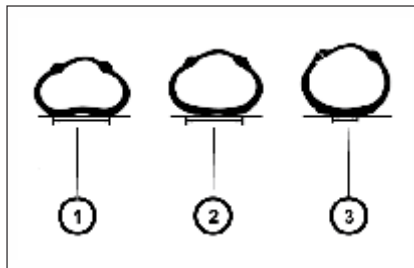

Refer to the tyre load information label for the correct tyre pressure. The label is on the sill plate below the driver's door.

At the time of cold start, check the tyre pressure with an accurate tyre pressure gauge. After check of tyre pressure, tighten the valve core cap.

### Note

**Make sure to check the tyre pressure at the time of cold start. The reading measured after the tyre temperature has increased shall not prevail. Tyres will become hot after traveling for 1.6 Km and will not cool down completely within 3h after stopping.**

Check the tyre pressure each time when refueling or at least every month. Incorrect tyre pressure may:

- Increase tyre wear
- Affect the vehicle manoeuvrability and safety
- Affect the riding comfort
- Reduce the fuel economy

### Note

- **Vehicle overload is prohibited.**
- **Be sure to keep a proper tyre inflation pressure.**
- **Be sure to check the tyre inflation pressure at the time of cold start (ambient temperature).**

Excessively low tyre pressure will cause overheat of the tyre, leading to internal damage and layered tread and even tyre burst when driving at a high speed. Even if the tyre pressure was restored later, driving under too low pressure may have damaged the tyre.

### Tyre and Wheel Maintenance

Running over sharp objects may damage tyres and wheels. If you have to run over these objects, please slow down.

Do not touch the curb when parking.

### Regular Tyre Check

- Appearance damage.
- Foreign material.
- Piercing.
- Cut.
- Crack.
- Protruding on side wall.

It shall also inspect the wheel for damage.

Tyre defects including the above defects may lead to vehicle out of control, causing personal injury.

In case of damage or abnormal wear of tyre or wheel, please consult the MG Authorised Service Center for help.

The vehicle is equipped with radial tyres. MG Motor suggests replacing with radial tyres of the same size, pattern, tread wear, temperature and rated speed.

### Note

The use of tyres with different size than the original tyres may cause the tyre and the vehicle component to interfere with each other, thus causing damage to the tyre and vehicle.

### Caution

If the vehicle is equipped with tyre pressure monitoring system, the tyre repairing liquid for tyre repair may result in the failure of the tyre pressure monitoring system sensor. It is suggested to go the MG Authorised Service Center for inquiries and repair.

### Internal Tread Wear Indicator

Check the tyre tread depth as per the tread wear indicator regularly. The mark on the tyre wall indicates the position of the tread wear indicator.

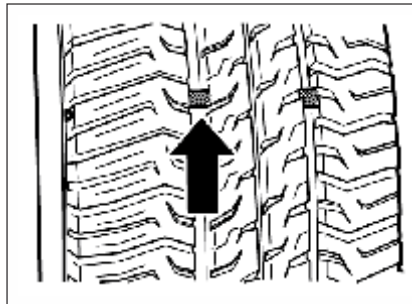

The tyre must be replaced when the tread wear indicator appears. When the tread depth is equal to or less than 1.6 mm due to wear, the tread wear indicator will appear between the tread grooves.

### Caution

Do not drive the vehicle in case of tyre wear or damage. The worn or damaged tyres may lead to the vehicle out of control and cause collision accidents, resulting in personal injury and damage of vehicle or other properties.

## Tyre Rotation

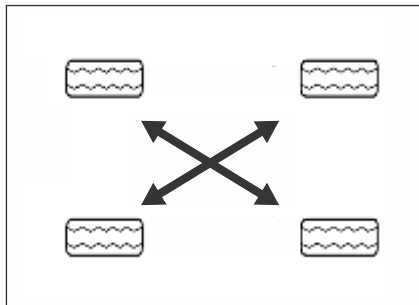

The front tyres and the rear tyres have different functions and therefore have different levels of wear. The front tyres wear faster than the rear tyres. In order to prolong the tyre life and avoid uneven tread wear:

1. Conduct tyre rotation as per maintenance regulations in the Manual.
2. Keep a proper tyre pressure.
3. Check nuts/bolts for tightening.

### Caution

**Please use the recommended wheels and wheel nuts/bolts. Otherwise, it may lead to the vehicle out of control and cause collision accidents, resulting in personal injury and damage of vehicle or other properties.**

### Note

**If the vehicle is equipped with tyre pressure monitoring system, after tyre rotation or tyre replacement, please go to the MG Authorised Service Center to realign the tyre pressure.**

## Winter Tyres

The use of winter tyres while driving on icy and snowy roads can improve driving safety. It is suggested to replace with winter tyres when the temperature is below 7 °C. Please select winter tyres with radial tyre structure and use such winter tyres on all four wheels. Please use the specified tyre pressure. Do not drive the vehicle at a speed exceeding the maximum speed specified by the tyre manufacturer. All-weather tyres can be used except winter tyres.

## Tyre Chain

Tyre chains are only used for emergencies or in areas clearly defined by law and should be installed on the drive wheels. Be especially careful when driving the vehicle equipped with tyre chains. Compared with tyres without tyre chains, when tyres are installed with tyre chains, the maneuverability of the vehicle is poor, and the tyre chain may damage the vehicle tyre, suspension or vehicle body. Therefore, use cable tyre chains as far as possible to ensure enough space between the tyre and other parts in the wheel casing. When using tyre chains, carefully read the installation and other related instructions of the tyre chain manufacturer.

### Note

**After installation of tyre chains, it is suggested to drive the vehicle at the speed of below 30 km/h or the limited speed recommended by the tyre chain manufacturer (whichever is smaller).**

## Spare Tyre, Jack and Tools

### Tool Kit

#### 5-seat Model



### Spare Tyre

The spare tyre, jack and tools are under the luggage compartment and can be seen after raising the luggage compartment floor. In-vehicle tools include the jack rocker, socket wrenches, traction hooks and screwdrivers.



### Take out the Spare Tyres

#### 5-seat Model

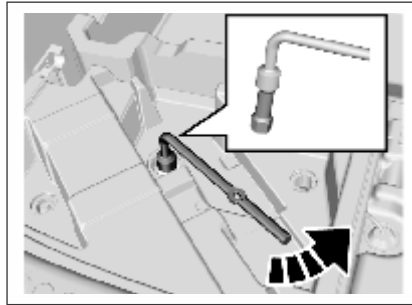

1. Open the liftgate and raise the luggage compartment floor.
2. Take out the tool bracket on the spare tyre. If the audio is equipped, disconnect its cable.
3. Rotate the butterfly nut in the center of the spare tyre counterclockwise to remove it, and then place it properly.
4. Take out the spare tyre.

### Jack Lifting Point

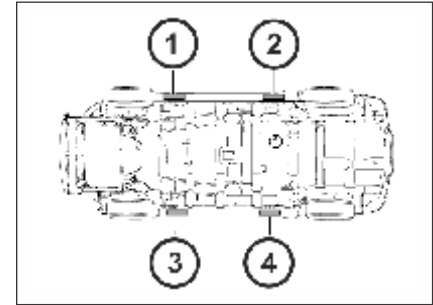

As shown in the figure above, the jack lifting points are around the side wall skirt, and there are triangle marks in corresponding parts for the convenience of searching.

These lifting points are also lifting points of the lifter, and the lifter tray should be aligned with the triangle mark. The lifting points have been specifically strengthened. Please be sure to align them.

## Tyre Replacement

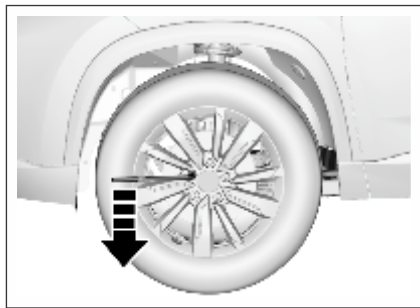

1. Take out tools, the jack and spare tyre. Check and confirm that the tyre on the diagonal is secured with blocks or stones.
2. Use a socket spanner to unscrew the wheel nut by one turn.

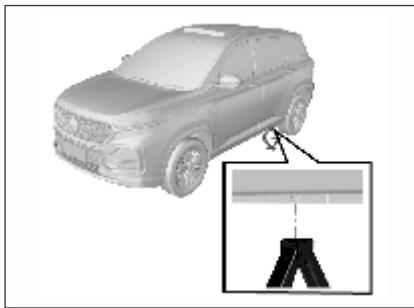

3. Place the jack just below the lifting point closest to the tyre that needs to be replaced. Align the slot on the jack head with the edgefold.

### Caution

**Do not remove any nut before wheels are lifted off the ground.**

### Warning

**Do not attempt to lift the vehicle before the jack is put into a proper position. The jack should be firmly secured between the vehicle and the ground.**

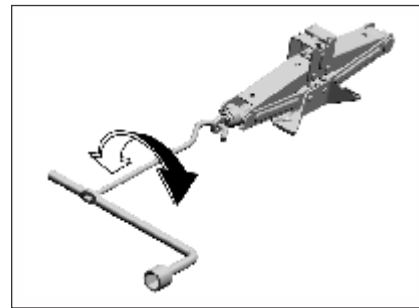

4. As shown in the figure above, connect the jack rocker to the jack.
5. Rotate the rocker clockwise to allow the jack to rise slowly and ensure that the jack head is firmly pushed into the lifting position.
6. After ensuring that the jack is in the correct position, continue turning the rocker until the tyre is about 3 cm off the ground.
7. Place the spare tyre at the vehicle bottom near the wheel to be replaced so as to prevent the vehicle from suddenly slipping.
8. Remove wheel nuts completely.
9. Remove the wheel to be replaced.
10. Install the spare tyre on wheel hub.

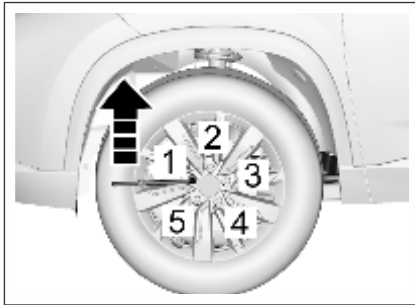

1. Install all wheel nuts and tighten them preliminarily.
2. Rotate the jack rocker counterclockwise to lower the vehicle to the ground stably.
3. Tighten the wheel nuts in the order 1-4-2-5-3 as shown in the figure above with the torque of 100~130 N•m.
4. Put the leaky tyre in the spare tyre storage location and secure it properly. Put tools back to the tool kit and secure them.

#### Caution

Make sure to use appropriate nuts and bolts, and tighten to the proper torque. The use of incorrect parts or improper tightening of vehicle nuts may cause damage to the vehicle or wheel falling off.

#### Caution

During the entire process the vehicle being lifted by the jack, ensure that the jack is placed vertically and no slipping occurs.

#### Note

Do not lift the vehicle to a height that exceeds the necessary height for wheel replacement.

#### Note

Please replace the leaky tyre as far as possible for further use. It shall check the spare tyres regularly to ensure that they can be used safely in case of emergency.

#### Caution

Do not work under the vehicle or start the engine when the vehicle is supported by a jack. The vehicle may slip off the jack, resulting in serious injury or death.

#### Note

When the vehicle jacking condition is unsatisfactory or if you do not have the confidence to safely complete this work, please contact the MG Authorised Service Center for help.

#### Caution

Do not apply oil or grease on the wheel nuts or bolts.  
Please use correct wheel nuts or bolts.  
Use a socket wrench to tighten nuts or bolts firmly.  
Please go to the MG Authorised Service Center as soon as possible and tighten wheel nuts or bolts according to specification. In case of improper tightening, nuts or bolts may be loose, resulting in accidents.

## Jump Start (Dead Battery)

### Caution

**When using the jack, the vehicle may become unstable and move, causing damage and personal injury. Please use the correct jack in normal state.**

**Before lifting, have all passengers leave the vehicle and stay away from traffic.**

**The jack is used for wheel replacement only.**

**Do not jack up the vehicle on a sloped or sliding ground.**

**Use the jack at the jack lifting point closest to the wheel that needs to be replaced.**

**Stop the wheel on the diagonal with wedges, blocks or stones so as to avoid vehicle moving.**

### Caution

**Before using the jack, make sure that the parking brake is pulled up, the transmission is at Gear I or reverse gear and the DCT automatic transmission is at P gear.**

**Avoid replacing wheels at traffic-intensive locations**

The vehicle with a low battery can be started by using the battery of other vehicles by the means of jump start.

If the battery is dead, please contact the MG Authorised Service Center for handling unless you confirm that you have enough electrical knowledge and you can safely complete this work.

### Caution

**Do not start the vehicle by the means of pushing or dragging. Otherwise, it may damage the catalytic converter and the transmission and even personal injury.**

### Preparation before Jump Start

1. Pull up the parking brake.
2. Ensure that the gearshift lever is at the neutral or P position.
3. Turn off all electrical accessories.

### Note

**Turn off the audio system before jump start of the vehicle. Otherwise, the audio system will be damaged. Please turn off unnecessary electrical devices when the vehicle is running at low speed for long time (in case of traffic jam).**

### Jumper Cable Connection

In case of jump start of the vehicle, connect the jumper cable in the following order:

1. Clip one end of the first jumper cable to the positive terminal of the powered battery. (There is a “+” mark on the battery housing or the terminal)
2. Clip the other end of the jumper cable to the positive terminal of the dead battery. (There is a “+” mark on the terminal)
3. Clip one end of the second jumper cable to the negative terminal of the powered battery. (There is a “-” mark on the battery housing or the terminal)
4. Connect the other end of the cable to the body ground of the vehicle that has no electricity.
5. While jump start, it is allowed to start the engine of the vehicle providing jump start power supply. Try to start the engine of the vehicle that has no electricity within one minute, and do not turn the ignition key more than 5s each time. After start, keep the rotation speed at 2000 (r/min) for several minutes.
6. To remove the jumper cable carefully in reverse order, remove the negative cable first and then the positive cable.



**Caution**

There is the risk of battery explosion. You may be burned by the battery acid, and an electrical short circuit can also cause personal injury or damage to the vehicle.

- Do not place the battery near an open flame or sparks. Do not tilt the vehicle body over the battery in case of jump start.
- Do not allow cable terminals to contact with each other.
- Wear safety goggles when working nearby the battery.
- Do not allow battery acid to come into contact with eyes, skin, fabric or painted surfaces.
- Ensure that the battery used for jump start has the same voltage as the voltage of original vehicle battery.
- Do not disconnect a dead battery from the vehicle.

When starting the engine with jumper cables, violation of the above precautions or the following instructions can cause the battery to explode, resulting in people being burned by battery acid or causing a short circuit.

This may damage the electrical system of both vehicles and cause serious personal injury.

**Caution**

Position the jumper cable properly and do not wrap it around rotating parts of the engine compartment.

Otherwise, it may damage the vehicle and cause personal injury.

**Caution**

It shall not be connected to the negative (-) terminal of the battery when it is finally connected to the vehicle that needs to be charged.

Connect the last connected clip to the bolt on the engine cylinder block steel bracket. The last connection point should be away from the battery as far as possible.

If the jumper cable is connected to the negative terminal of an uncharged battery, it may produce electric arc and cause the battery to explode.

It will cause serious personal injury or damage the vehicle.

**Note**

It shall start the engine of the vehicle with a discharged battery at an interval of about 1 minute, and the time for each start cannot exceed 15s.

**Caution**

Do not use the battery as a jump source for other appliances for a long time. Otherwise, it is easy to make the battery lose electricity and may even cause safety accidents.

## Vehicle Traction

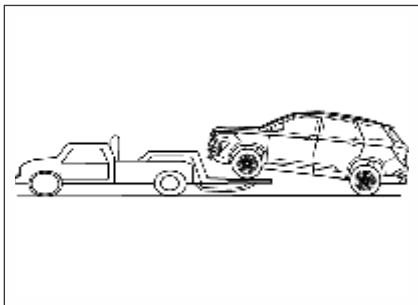

If vehicle traction is necessary, please contact the MG Authorised Service Center or a professional traction service company.

### Note

**Do not tow the vehicle with lifting chain type equipment. It must use plates or wheel lifting equipment.**

### Caution

- It is prohibited to allow passengers to be seated in the towed vehicles.
- The towing speed is not allowed to exceed the safe speed or the indicated road speed limit.
- It is prohibited to use damaged parts that are not firmly secured onto the vehicle for traction. Failure to comply with the above precautions may result in personal injury.

## Vehicle Traction with Wheel Lifter

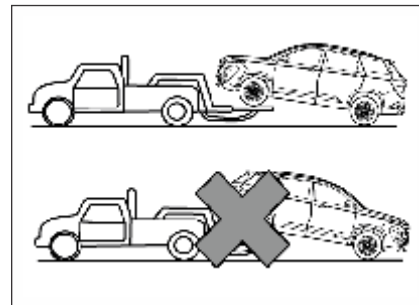

1. Turn on the hazard warning flasher.
2. Turn the ignition switch to ACC position.
3. The transmission must be in neutral gear.
4. Release the parking brake.
5. Front wheels must be off the ground when towing.

### Vehicle Traction with Platform Trailer

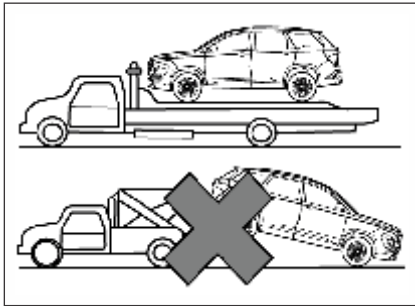

When towing the vehicle with a platform trailer, turn off the ignition switch and check that the vehicle is firmly attached to the trailer.

#### Note

**If the vehicle must be towed from the rear, please use traction device supporting wheels under the front wheels. The front wheels should not be on the ground when the vehicle is towed from the rear. Otherwise, it may cause serious damage to the vehicle transmission.**

### Emergency Trailer

#### For MT or DCT model

If the trailer is not available in case of an emergency, it can secure the rope on the front towing hook under the vehicle for temporary vehicle traction. When the vehicle is towed via the front towing hook, only traction rope can be used. Do not use a rigid tow bar.

No matter MT or DCT model, engage the neutral (N) gear and release the hand brake when the vehicle is towed.

If equipped with CVT, do not use a rope for traction. Only a platform trailer is allowed for carrying. When the vehicle is trapped in quagmire or slips in a pit, a rope can be used for traction, but long-distance traction is not allowed.

#### Notes on AT Model Traction

If the automatic transmission is faulty, the neutral (N) gear may not be engaged. In this case, if vehicle traction is required, the drive shafts of the two front wheels should be removed first; otherwise, the transmission may be damaged. It is suggested to contact the MG Authorised Service Center for solution.

### Front Towing Hook

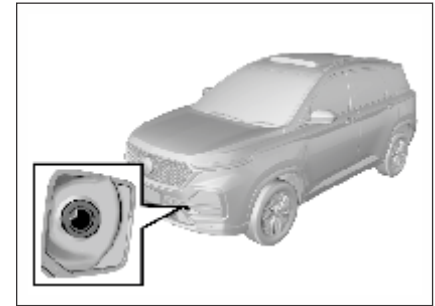

There is a hole cover on the right side of the front bumper of the vehicle. Open it and the fixing hole for hook installation can be seen.

The towing hook is on the tool bracket under the luggage compartment floor. Take out the towing hook and install it into the fixing hole. Rotate the towing hook clockwise to tighten it completely and insert a socket wrench into the hook hole to assist tightening. Be sure that the towing hook is installed firmly before towing the vehicle. When towing the vehicle, the driver must control steering and braking in the vehicle. After completion of traction, remove the towing hook and close the hole cover, and then put the towing hook back into the tool kit.

## Rear Towing Hook

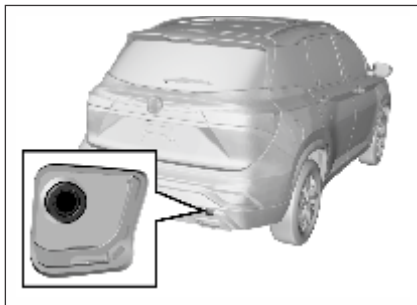

There is a hole cover on the left side of the rear bumper of the vehicle. Open it and the fixing hole for hook installation can be seen.

Take out the towing hook and install it into the fixing hole. Rotate the towing hook clockwise to tighten it completely and insert a socket wrench into the hook hole to assist tightening. Be sure that the towing hook is installed firmly before towing the vehicle.

Do not tow vehicles that are heavier than this vehicle; otherwise, it may damage the vehicle or cause accidents.

### Note

The vehicle may be damaged when it is towed by ropes. To reduce damage:

- The towing hook must be used when other traction devices are not available.
- The vehicle shall be towed from the front only.
- Keep the traction rope out of contact with the bumper.
- Make sure that both ends of the traction rope are firmly secured on the towing hook. Pull the traction rope for inspection.
- Drive the vehicle at a low speed and avoid sharp turning.

### Note

The vehicle may be out of control when it is towed by ropes.

To reduce damage:

- The towing distance shall not be too long, and the vehicle should be towed at a low speed.
- Do not tow the vehicle if the wheel, transmission, axle, steering or brake damage is damaged.
- Do not remove the key from the ignition switch; otherwise, the steering will be locked so that the vehicle cannot turn.

### Caution

The towing speed shall not exceed 30 Km/h, and the towing distance shall not exceed 40 Km. When long-distance towing is required, it is suggested to contact the MG Authorised Service Center or a professional towing service company for help.

### Caution

CVT models are not allowed to be towed and must be transported by platform trailer otherwise the transmission will be damaged.

## Getting Vehicle out of Trap

When the vehicle is caught in snow, puddle or other unstable ground, please follow the procedures below to get the vehicle out of trap.

1. Turn the steering wheel to the ultimate left and then turn it to the ultimate right. This will create a vacant area around the front wheels.
2. Engage the reverse gear and drive gear back and forth.
3. Reduce wheel idling as far as possible.
4. Release the accelerator pedal when shifting gear.
5. After engaging the gear, depress the accelerator pedal gently.

If it fails to get the vehicle out of trap, it is necessary to tow the vehicle.

### Caution

**When the vehicle is caught in snow, puddle or sandy soil, you need to get the vehicle out of the trap as soon as possible.**

**First, check whether there are obstructions or people around the vehicle.**

**During operation, the vehicle may suddenly move forward or backward, hitting the person or object next to it.**

### Note

**In order to avoid damage to the transmission and other parts, the following precautions must be observed when getting the vehicle out of the trap.**

- **Do not depress the accelerator pedal during gear shifting or when the transmission is not in a proper gear position.**
- **High engine speed is not allowed, and wheel idling shall be avoided.**
- **If it fails to get the vehicle out of trap after several efforts, consider other methods, such as traction.**

## Vehicle Maintenance

### Cleaning Agent

The manufacturer's suggestions must be observed when using cleaning agent or other chemical products inside or outside the vehicle.

Do not use dangerous cleaning agent when cleaning the interior and exterior of the vehicle. For example:

- Acetone
- Paint diluent
- Porcelain glaze reducing agent
- Nail polish remover

When cleaning the interior and exterior of the vehicle, the following cleaning agents are prohibited unless special instructions for cleaning stains are included in the fabric cleaning tips:

- Laundry soap
- Bleaching powder
- Reducing agent

### Caution

**Some cleaning agents are toxic, corrosive or flammable. Improper use is very dangerous and may easily cause personal injury or vehicle damage.**

Do not use the following materials for cleaning:

- Carbon tetrachloride
- Gasoline
- Benzene
- Naphtha

When using any cleaning agent or other chemical products inside the vehicle, please open the doors for proper ventilation.

To avoid permanent color change of light-colored interior trims, do not allow the easy-to-discolor fabrics to come into contact with the seat liner unless both materials are completely dry. Fabrics with easy-to-discolor materials are:

- Casual clothes
- Dyed denim
- Leather
- Kidskin
- Newspapers and decorative paper

### Caution

**Avoid prolonged exposure to cleaning agents and other chemical vapors. Such chemical vapor is extremely dangerous and harmful to the health, especially in limited space without ventilation.**

### Vehicle Interior Maintenance and Cleaning

Clean the interior and exterior of the vehicle with proper cleaning methods and materials.

Use a vacuum cleaner or a banister brush to remove dust and scum that accumulate on the fabric inside the vehicle frequently.

Wipe the vinyl plastics and leather trims regularly with a clean wet cloth.

Remove dust, spots or stains on trims with a suitable cleaning agent.

### Caution

**Clean the interior trims of the vehicle with proper cleaning methods and materials.**

**Otherwise, it will produce water spots, watermarks and permanent spots, especially during the first washing. These substances will permanently damage the vehicle.**

### Seat Belt Maintenance

Keep the seat belts clean and dry. Prevent seat belts from being contaminated by polishing agents, oils and chemical products, especially battery fluid, bleaching powder or dyestuff. These contaminants will reduce the strength of the seat belt material. Check all seat belt parts regularly. Replace any damaged seat belt or part immediately.

The seat belt or related parts that are stretched during the accident must be replaced, even if the damage is not obvious or is not visible. The seat belt for replacement must be new.

MG Motor suggests replacing the whole seat belt assembly after collision. It is not necessary to replace the seat belt after it is checked to be undamaged and normal by the MG Authorised Service Center for solution.

### Note

**The seat belt must be kept in good working condition to maintain its normal function.**

### Glass Surface

Make sure that the window glass is clean, which helps reduce glare and improve vision.

### Front Windshield Outside Cleaning

Waxes or other materials on the front windshield and blade may cause the blade to shake when working. Moreover, such foreign matters are not conducive to keeping the front windshield clean. Clean the outside of the front windshield regularly with a non-abrasive cleaning agent.

Water does not form water droplets on the clean front windshield.

**Note**

The non-abrasive cleaning agent will scratch the glass and damage the rear windshield defroster grid lines.

Do not use abrasive cleaning agent on vehicle glass. Otherwise, it will affect the driver's vision.

**Note**

Decals will affect the rear windshield defroster.

Do not paste decals on the inner side of the rear windshield. Otherwise, it will affect the driver's vision.

## Vehicle Exterior Maintenance and Cleaning

### Vehicle Washing

The best way to maintain the finish paint of vehicles is to wash it regularly and keep it clean.

- Park the vehicle in the place where is not directly exposed to sunlight.
- Wash the vehicle with the specified neutral soap liquid and cold or warm water.
- Be sure to remove the soap liquid and cleaning agent from the surface by the means of flushing.

MG Motor vehicles are designed to operate under normal environmental conditions and natural factors.

**Note**

Do not use household dishwashing detergent to wash the vehicle. The dishwashing detergent can wash off paint and wax.

Avoid excessive vehicle washing pressure. Water may enter the vehicle and damage the interior.

### Polishing and Waxing

Regular polishing can remove residues from the surface of the vehicle. After polishing, use high-quality car wax for protection.

**Note**

It is forbidden to clean or polish aluminum trims with automotive or chrome polishing agent, steam or alkaline soap liquids. These substances are abrasive and may damage trims and wheels.

### Exterior Bright Metal Parts Protection

Clean the bright metal trims regularly. They are usually washed with water. When waxing the vehicle, please also wax these bright metal parts.

## Aluminum Wheels and Wheel Trim Cover Cleaning

To maintain the original appearance of the wheel and wheel trim cover (if any), do not allow them to collect dust or brake dust.

Clean the wheel / wheel trim cover regularly. Do not use abrasive cleaning agent or brush that may damage the finish paint.

**Note**

Do not use abrasive cleaning agent or brush to clean aluminum wheels or wheel trim covers.

**Warning**

- Keep yourself, test leads, clothing, and other objects clear of electrical connections and hot or moving engine parts.
- Do not wear watches, rings, or loose clothing when working in an engine compartment.
- Make sure no loose material (Cloth or other inflammable material etc) is left (but not limited to) inside engine compartment / Engine Cover / Fender after washing.

### Corrosion Prevention

MG Motor vehicles are designed to have anti-corrosion capabilities. The use of special materials and protective paint on most vehicle parts helps maintain satisfactory appearance, strength and reliability.

Although the surfaces of certain parts inside the engine compartment or of the underbody may rust, the reliability or performance of these parts will not be affected.

#### Metal Plate Damage

If the body needs to be repaired or replaced, ensure that the repair shop uses proper anti-corrosion materials to restore the anti-corrosion protection performance.

#### Foreign Matter Deposition

The following substances may damage the paint surface:

- Calcium chloride and other salts
- Ice melting agent
- Road surface oil and asphalt
- Sap
- Bird droppings
- Industrial dust

Remove harmful substances on the vehicle in time. If residues cannot be removed with soap liquid, a special cleaning agent can be used.

#### Finish Paint Damage

Repair the gravel scratches, cracks or deep scratches on the finish paint as soon as possible. Exposed metal is prone to corrosion. Quick-drying products can be used to repair tiny cracks and scratches. Body and paint repair shops can complete large-scale repairs.

<b>Note</b>
<p><b>Only safe cleaning agents that are harmless to the paint surface can be used.</b></p> <p><b>Other cleaning agents may permanently damage the paint.</b></p>

#### Underbody Maintenance

Corrosive substances used for ice and snow melting and dust prevention may accumulate at the underbody. Failure to remove these substances will accelerate corrosion and rusting.

Flush the underbody with clean water regularly. Clean the part where the mud is prone to accumulate carefully. Loosen the

accumulated dirt in the enclosed area before flushing with water.

When necessary, please contact the MG Authorised Service Center for service.



## Technical Data

<b>Vehicle Identification .....</b>	<b>194</b>
• Identification Number (VIN) .....	194
• Vehicle Identification Tag .....	194
• Engine Identification Number .....	194
<b>Vehicle Data .....</b>	<b>195</b>
• Vehicle Tools .....	202

## Vehicle Identification

### Vehicle Identification Number (VIN)

There are 3 commonly used vehicle identification numbers on your car.

Remember :

#### Seat floor vehicle identification number

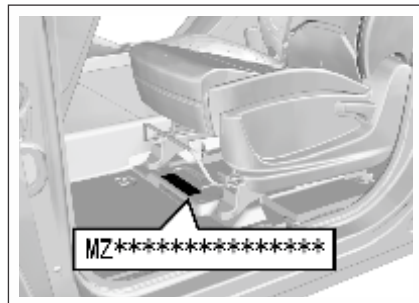

The VIN print stamp is located under the front passenger seat.

Square floor

### Vehicle Identification Tag



The sign is a paper sign and is located on the passenger side car.

On the door frame.

### Engine Identification Number

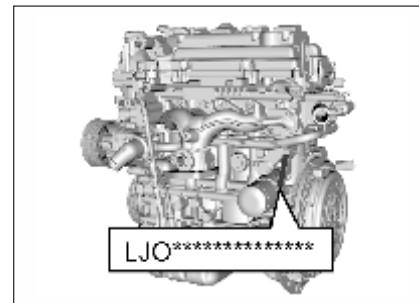

The rubbed stamp is located on the engine block.

Near the flywheel.

## Vehicle Data

## Main Engine Performance Parameters

Item	Unit	Parameter	
		Engine Model: LJO	Engine Model: 2.0D
Engine Type		Four-stroke, water-cooled, in-line, 16-valve, dual overhead camshaft, inlet VVT (inlet variable camshaft phase), timing chain drive, naturally aspirated, electronically controlled gasoline injection, electronically controlled ignition	Four Stroke, Water Cooled, In-Line, 16 Valve, DOHC, Timing Belt Drive, Direct Injection, Common Rail, VGT Turbo Charger with Electric Actuator
Bore diameter × stroke	mm × mm	73.8 × 84.7	83 × 90.4
Displacement	L	1.45 l	1.956
Compression ratio	-	9.8	16.5
Maximum net power / speed	kW / (r / min)	105 / 5000	125 / (3700 ~ 3800)
Maximum net torque	Nm / (r / min)	250 / 2400	350 / (1750 ~ 2500)
Idle Speed	r/min	750±50	850±50
Drive Type		Front wheel drive, forward	
Complete vehicle emission standard		BS4 OR BS6	

**Main Vehicle Quality Parameters**

Project	Unit	Parameter				
		NI5T 6MT	NI5T DCT	NI5T 6MT BSG	NI5T CVT	2.0D 6MT
Number of People		5*/6*/7*	5*/6*/7*	5*/6*/7*	5*/6*/7*	5*/6*/7*
Curb Weight	kg	1544, 1556, 1576, 1613	1612, 1649	1580, 1600, 1637	1616,1655,1628,1667	1658, 1670, 1690, 1727
Front axle load of curb weight	kg	919, 925, 932, 944	968, 980	943, 950, 962	970,983,969,982	1006, 1012, 1019, 1031
Rear axle load of curb weight	kg	625, 631, 644, 669	644, 669	637, 650, 675	646,672,659,685	652, 658, 672, 696
Total mass	kg	2100	2100	2100	2140	2180
Front axle load	kg	1050	1050	1050	1065	1120
Rear axle load	kg	1050	1050	1050	1075	1060

\*Above values may vary depending on seating capacity of the vehicle.  
Please contact MG Dealer for more information

### Vehicle Main Size Parameters

Project	Unit	Parameter Value				
		NI5T 6MT	NI5T DCT	NI5T 6MT BSG	NI5T CVT	2.0D 6MT
Overall length	mm	4 655				
Total width	mm	1 835				
Total height (no load)	mm	1 760				
Wheelbase	mm	2 750				
Front overhang	mm	950/975				
Rear overhang	mm	955/995				
Front track	mm	1 554				
Rear track	mm	1 549				
Approach angle (no load/full load)		20,19/19				
Departure (angle Load)		21/18,15				
Minimum ground clearance (full load)	mm	180	180	180	180	175
Minimum turning diameter	m	11.9				

TECHNICAL DATA

**Power / Dynamic Performance Parameter**

Project	Unit	Parameter				
		N15T 6MT	N15T DCT	N15T 6MT BSG	N15T CVT	2.0D 6MT
Maximum Speed	Km/h	≥170				≥180
Maximum climbing gradient	%	≥30				≥30

\*Above values may vary depending on road condition and specific country regulation.  
Please contact MG Dealer for more information.

**Main Liquid Parameter**

Name		Brand / Specification	Capacity, L				2.0D 6MT
			N15T 6MT	N15T DCT	N15T 6MT BSG	N15T CVT	
Motor Gasoline*		India 91 and above	60		-	60	-
		India 92 and above		-	60	-	-
Vehicle Diesel*		CN51 and above diesel	-			-	60
Engine Oil*	N15T	SN/GF-5 5W-30	4.0				-
	2.0D (BS4)	SAE 5W30 ACEA C2	-				4.8
	2.0D (BS6) (with DEF)*	SAE 0W-20 ACEA C2					4.8
Transmission Oil*	6MT / BSG	75W/90	2.0±0.15	-	2.0±0.15		-
	DCT	FFFL-2	-	6.5±0.2	-		-
	2.0D 6MT	75W	-	-	-		2.0
	CVT	Shell SL2100	-	-	-	4.0±0.2	
Coolant*		Glycol type anti-freeze	8±0.5				10±0.5
Brake Fluid (including Hydraulic Clutch Solution)*		DOT4	0.75±0.05				
Air Conditioning Refrigerant*		HFC-134a	690± 20g (5 seater) / 1050± 20g (6/7 seater)				
Diesel Exhaust Fluid (DEF)*		Standard – ISO 22241	As Required				

\*Specification may vary depending on vehicle manufacturing date. Please contact MG Authorized Workshop for exact specification of lubes / oils / fluids in your vehicle.

**Tyre Inflation Pressure (Cold State)**

Tyre Model	Project	Tyre Inflation Pressure (unit: Psi)	
		At no load	At full load
215/60R17	Front Tyre	34	
	Rear Tyre	34	
215/55R18	Front Tyre	35	
	Rear Tyre	35	

**Wheel Alignment Parameters (No Load)**

Project		Range (Unit: Degree)
Front Wheel	Camber	-26'±45'
	Caster	4°15'±45'
	Toe	0±5'
	King Pin Inclination	12°7'±1°
Rear Wheel	Camber	-1°±45'
	Toe	11'±20'



**Other Parameters**

<b>Project</b>	<b>Parameters</b>
Requirement for dynamic balance of wheels	Dynamic unbalance <15 g
Reasonable range of brake pedal free travel	<30 mm
Minimum scrapping thickness of front brake disc	24mm
Minimum scrapping thickness of front brake lining	2mm
Minimum scrapping thickness of rear brake disc	8mm
Minimum scrapping thickness of rear brake lining	2mm

**Vehicle Tools**

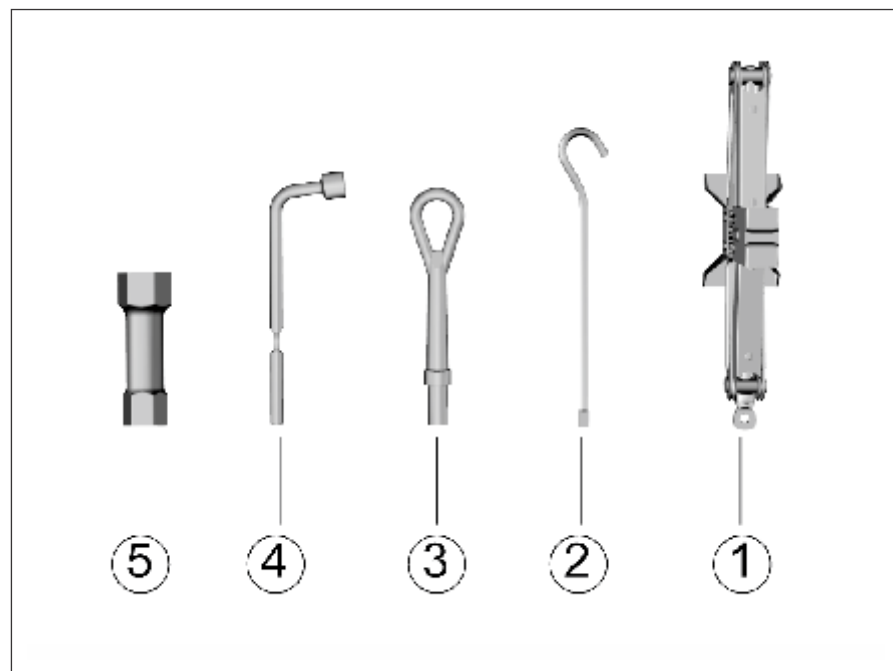

1. Jack
2. Jack Rocker
3. Traction Hook
4. Wheel Nut Wrench
5. Sleeve

## DELIVERY OF YOUR VEHICLE

Dealer Name..... Dealer Address.....

FIRST NAME ..... SURNAME .....

MODEL .....

VEHICLE DELIVERED ON ..... BY .....

### PRESENTATION AND EXPLANATION

#### 1 FRONT OF THE VEHICLE

Eg. Servicing details, Checking the levels

#### 2 FRONT PASSENGER SIDE

Eg. Disconnecting the passenger airbag (to fit a child seat to the front seat)

#### 3 REAR OF THE VEHICLE

Eg. Location of the spare wheel, tool kit

#### 4 REAR SEATS

Eg. Child safety (Isofix fixing point)  
Modularity of the seats

- » Was your vehicle presented to you as stated above?  
 YES                       NO
- » Did your vehicle match your vehicle order?  
 YES                          NO

#### 5 DRIVING POSITION

Eg. Adjusting the driving position. Use of the instrument panel and controls. Specific points relating to your vehicle.  
Eg: Programming the radio, bluetooth, automatic illumination of the headlights, etc.

#### 6 DEALER SERVICE DEPARTMENT

#### 7 WARRANTY AND MAINTENANCE CONDITIONS

Eg. Warranty and maintenance documents (Service sheet or warranty & maintenance booklets), maintenance stamps

#### 8 ISSUED WITH

- Two set of keys
- Tool kit
- Spare tyre
- Vehicle invoice
- Insurance cover note
- Registration document
- Vehicle manual

## DELIVERY OF YOUR VEHICLE

Comments:

.....

.....

.....

Please note that MG Motor India will not be responsible for any issues pertaining to Non Genuine Accessories fitted either by dealership or aftermarket.

Should you require any further details regarding the vehicle handover or if you have any questions relating to your vehicle, please do not hesitate to contact your Sales or Delivery Advisor.

**ENJOY DRIVING YOUR NEW MG!**

CUSTOMER SIGNATURE

DELIVERY ADVISOR SIGNATURE

1st EXEMPLARY : CUSTOMER  
2nd EXEMPLARY : DELIVERY ADVISOR

## DELIVERY OF YOUR VEHICLE

Dealer Name..... Dealer Address.....

FIRST NAME ..... SURNAME .....

MODEL .....

VEHICLE DELIVERED ON ..... BY .....

### PRESENTATION AND EXPLANATION

#### 1 FRONT OF THE VEHICLE

Eg. Servicing details, Checking the levels

#### 2 FRONT PASSENGER SIDE

Eg. Disconnecting the passenger airbag (to fit a child seat to the front seat)

#### 3 REAR OF THE VEHICLE

Eg. Location of the spare wheel, tool kit

#### 4 REAR SEATS

Eg. Child safety (Isofix fixing point)  
Modularity of the seats

- » Was your vehicle presented to you as stated above?  
 YES                       NO
- » Did your vehicle match your vehicle order?  
 YES                          NO

#### 5 DRIVING POSITION

Eg. Adjusting the driving position. Use of the instrument panel and controls. Specific points relating to your vehicle.  
Eg: Programming the radio, bluetooth, automatic illumination of the headlights, etc.

#### 6 DEALER SERVICE DEPARTMENT

#### 7 WARRANTY AND MAINTENANCE CONDITIONS

Eg. Warranty and maintenance documents (Service sheet or warranty & maintenance booklets), maintenance stamps

#### 8 ISSUED WITH

- Two set of keys
- Tool kit
- Spare tyre
- Vehicle invoice
- Insurance cover note
- Registration document
- Vehicle manual

## DELIVERY OF YOUR VEHICLE

Comments:

.....

.....

.....

Please note that MG Motor India will not be responsible for any issues pertaining to Non Genuine Accessories fitted either by dealership or aftermarket.

Should you require any further details regarding the vehicle handover or if you have any questions relating to your vehicle, please do not hesitate to contact your Sales or Delivery Advisor.

### ENJOY DRIVING YOUR NEW MG!

CUSTOMER SIGNATURE

DELIVERY ADVISOR SIGNATURE

1st EXEMPLARY : CUSTOMER  
2nd EXEMPLARY : DELIVERY ADVISOR

## MG Motor New Vehicle Warranty

### Terms & Conditions

INDIA

#### 1. **Warning:**

Your MG MOTOR vehicle is manufactured to meet the regulations and environmental requirements for Indian conditions. In case you relocate it to any other country than INDIA, it may be very difficult to make modifications to comply with the regulations and environmental requirements of that country and it may be difficult to perform repair service in that country.

Please note that a MG MOTOR vehicle relocated to any other country than India shall not be covered by the warranty.

#### 2. **The MG MOTOR New Vehicle Warranty**

##### 2.1 Duration of MG MOTOR'S New Vehicle Warranty:

Vehicles in the MG MOTOR range, delivered as new from 1st April 2019 to the Customer by an authorized

MG MOTOR DEALER, are warranted against any material, assembly or Manufacturing Defects by the Manufacturer. The New Vehicle shall be covered under a Warranty by MGMTOR for a period of

- **Personal Registration** - 5 years or Unlimited kilometers (whichever is earlier)
- **Commercial Registration** - 5 years or 1,50,000 kms (whichever is earlier)

MG Motor new vehicle warranty starts from the Delivery Date shown in the Owner's Manual issued to the Customer / First Owner of the vehicle upon delivery of the vehicle purchased. (Transfer of ownership of the vehicle does not alter the warranty period of a vehicle.)

##### 2.2 **Geographical coverage:**

##### 2.2.1 This warranty covers any new vehicle sold within geographical boundaries of INDIA.

If the vehicle is to be driven and, more importantly, registered outside the

geographical area defined above, such vehicle will not be covered under the current warranty as stated herein.

##### 2.3 The period of warranty on the vehicle shall not be deemed to be extended by repairs or replacements of any parts.

##### 2.4 In the event the Original Purchaser of the vehicle transfers the vehicle during the period of warranty, it shall be obligation of the subsequent purchaser to notify and inform MG Motor or its authorized dealer of such transfer.

#### **Field of Application:**

##### 2.5 **The Customer is covered for:**

##### 2.5.1 Free repair (parts, consumables and labour) of any material or assembly defect duly found in the vehicle, at their own request, as well as any repairs on damage caused by this defect to other vehicle parts.

##### 2.5.2 24/7 assistance services as defined in the "MG MOTOR Road Side Assistance" section.

It is the authorized MG MOTOR Dealer's discretion to decide whether it is appropriate to repair or replace the defective part, whilst keeping the Customer informed.

**2.6 Parts not covered under warranty conditions contained herein:**

The following are the parts not covered by warranty conditions contained herein. Hence, it is requested to contact your nearest MG MOTOR Dealer for more details.

**2.6.1 Battery:** The warranty coverage for 12V / 48V Battery is valid for 1 year starting from the Delivery Date shown in the Owner's Manual issued to the Customer and shall be provided by the battery manufacturer as per their terms and conditions.

**2.6.2 Tyre:** The warranty coverage for Tyre is valid for 1 year starting from the Delivery Date shown in the Owner's Manual issued to the Customer and shall be provided by the respective tyre manufacturer as

per their warranty terms and conditions.

**2.6.3 Infotainment / Audio system:** The warranty coverage for Infotainment / Audio system is valid for 3 years from the Delivery Date shown in the Owner's Manual issued to the Customer and shall be provided by the respective manufacturer as per their terms and conditions.

The MG MOTOR New Vehicle Warranty does not cover and MG MOTOR India Private Limited (MG MOTOR) and / or MG MOTOR authorized workshop shall not be responsible for the following:

**2.7** Normal maintenance services other than 5 free services, including without limitation, cleaning and polishing, minor adjustments, engine tuning, oil top-up / fluid changes, Diesel Exhaust Fluid (DEF) top-up / replacement, filters replenishment, fastener re-tightening, wheel balancing, wheel alignment and tyre rotation etc.

The indirect and remote consequences of any fault (loss of operation, duration of immobilization, etc.);

Vehicle components which have undergone conversion work, and/or specification and design changes and the consequences (deterioration, premature wear and tear, alterations, etc.) of the conversion work on other vehicle parts or components, or on its specifications;

The costs incurred by the Customer for routine maintenance;

Replacement of parts due to normal wear and tear resulting from use of the vehicle or from its mileage including but not limited to clutch, shocker absorbers, wiper blades, brake drum, brake disk, brake pads, brake shoe, lamp, plugs, belts, linings, bulbs, fuses, parts made of rubber, etc.

**2.8 Damage or failure resulting due to the following causes:**

**2.8.1** Poor vehicle maintenance, in particular if the instructions for the



treatment, the frequency of maintenance or care to be applied to the vehicle set out in the Owner's Manual have not been observed;

- 2.8.2** Due to lack of use / operation of vehicle over prolonged period[s];
- 2.8.3** Misuse, abuse, negligence, improper driving habits, theft etc. of the vehicle;
- 2.8.4** Damage from stress, like use of vehicles in races, rallies or as taxis. The warranty terms for the use of MG Motor vehicle shall be different / separate from the terms contained herein.
- 2.8.5** Use of parts other than MG MOTOR Genuine Parts.
- 2.8.6** Any device and / or accessories not Supplied / Fitted by MG MOTOR.
- 2.8.7** Modifications, alterations, tampering or improper repair.
- 2.8.8** Parts used in applications of which they were not designed or not approved by MG MOTOR.

Slight irregularities not recognized as affecting quality or function of the

vehicle or parts, such as slight noise or vibrations, or items considered characteristic of the vehicle.

**2.9 Damage caused by the following external causes:**

- 2.9.1** Accidents, impacts, scratches, scoring, projection of gravel or solid bodies, hail, acts of vandalism;
- 2.9.2** Failure to observe the Manufacturer recommendations;
- 2.9.3** Deposits due to atmospheric pollution, plant-based deposits such as resin, animal-based deposits such as bird droppings, chemical deposits;
- 2.9.4** Transportation of the vehicle;
- 2.9.5** Using an adulterated / incorrect fuel;
- 2.9.6** Fitting accessories not approved by the manufacturer;
- 2.9.7** Fitting accessories approved by the manufacturer, but installed without observing the recommendations defined by the manufacturer;
- 2.9.8** Damage due to airborne fallout, industrial fall out, acid rain, hail and wind storms, or other force majeure

events like lightning, fire, floods, earthquakes, war, riots, attacks etc.;

- 2.9.9** Damage caused due to hydro-static lock.
- 2.9.10** Damage caused due to rodents;
- 2.9.11** Paint scratches, dents or similar paint or body damage.

Incidental or consequential damages, including without limitation, loss of time, inconvenience, loss of use of vehicle or commercial loss.

**How does the MG MOTOR New Vehicle Warranty work?**

- 2.10** To be eligible for the MG MOTOR New Vehicle Warranty, the Customer must:
- 2.10.1** check that the Owner's Manual does contain the Delivery Date of the vehicle - their warranty entitlement is dependent on this;
- 2.10.2** contact any workshop of the MG MOTOR Authorized Workshop Network – only such Workshop have the authorization for operations of this sort;

- 2.10.3 show the duly completed Owner's Manual, as proof of entitlement to the warranty and that the maintenance operations recommended by the Manufacturer have been carried out;
- 2.10.4 have the defect covered by the MG MOTOR New Vehicle Warranty confirmed as soon as possible, by a MG MOTOR authorized workshop in writing. If the vehicle is unroadworthy, the Customer must contact the nearest MG MOTOR authorized workshop member or MG MOTOR Assistance.
- 2.11 The MG MOTOR New Vehicle Warranty does not apply, and MG MOTOR and MG MOTOR authorized dealer members are exempt from all liabilities, if:
  - 2.11.1 The vehicle has been driven under conditions not in accordance with those stated in the Owner's Manual (example: vehicle overloaded or taking part in any type of sports competition, etc.);  
The defect observed is due to the Customer having had the vehicle repaired or serviced in a workshop outside the MG MOTOR authorized network and not observing MG Motor's recommendations on the subject.
- 2.12 By way of consideration for the parts supplied by MG MOTOR under the MG MOTOR New Vehicle Warranty, parts replaced under this warranty, shall legally become the property of MG MOTOR.
- 2.13 All operations, parts and labour, carried out under the MG MOTOR New Vehicle Warranty are guaranteed until the new vehicle warranty expires.
- 2.14 Transferring ownership of the vehicle shall not alter the application conditions of the MG MOTOR New Vehicle Warranty.
- 3. **The MG MOTOR Anti-corrosion Warranty:**
  - 3.1 **Duration of the Anti-Corrosion Warranty:** This warranty will apply from the delivery date given on the Owner's Manual for a period of:
    - **Personal Registration** - 5 years or Unlimited kilometers (whichever is earlier)
    - **Commercial Registration** - 5 years or 1,50,000 kms (whichever is earlier).
  - 3.2 **Geographical Coverage:** The geographical coverage of the Anti-Corrosion Warranty is identical to that for the MG MOTOR New Vehicle Warranty.
  - 3.3 Anti-Corrosion Warranty field of application
    - 3.3.1 In addition to the MG MOTOR New Vehicle Warranty, MG MOTOR guarantees the bodywork and sub frame of MG MOTOR vehicle Schedule I from perforation from the interior, due to steel panel corrosion caused by a manufacturing, material or protective product application defect.
    - 3.3.2 This guarantee covers the repair or replacement of components with perforated steel panel work due to a

manufacturing, material or protective product application defect, acknowledged by the Manufacturer.

**3.3.3** It is authorized MG MOTOR workshop's discretion to decide whether it is appropriate to repair or replace these components, and to inform the Customer.

**3.4 The MG MOTOR Anti-Corrosion Warranty does not cover:**

**3.4.1** any damage which is not covered by the MG MOTOR New Vehicle Warranty, as defined at the start of this booklet; Mechanical components which are not an integral part of the bodywork or sub-frame (wheel rims, exhaust system, etc.).

**3.4.2** In case, repairs (including denting or painting) have been carried out on the body of the MG Motor Vehicle in a workshop outside the MG MOTOR authorized network.

**3.5** Anti-Corrosion Warranty conditions of application

**3.5.1** To obtain the Anti-Corrosion Warranty, the Customer must contact any Workshop of the MG MOTOR Authorized Workshop Network - only such Workshop have authorization for operations of this sort.

**3.5.2** The Customer shall show the duly completed (delivery date and validation of anti-corrosion test coupons) the Owner's Manual as proof of their warranty entitlement.

**3.5.3** Application of the MG MOTOR Anti-Corrosion Warranty is subject to the anti-corrosion tests on the bodywork and sub-frame. Customer shall ensure that these tests are conducted at the mileage intervals stated in the Owner's Manual, and at least once every two years. Scheduled maintenance services in the MG MOTOR authorized workshop network incorporate these tests.

**3.5.4** If the Customer requests to have the anti-corrosion test conducted independently of the scheduled

maintenance service, the same will be carried out at an extra cost to the Customer.

**3.5.5** During these tests the Customer shall make sure that the professional carrying out the operation correctly completes the bodywork and sub frame test coupon, in order to validate the continuation of the Anti-Corrosion Warranty.

**3.5.6** Repairs on any deterioration must be made as soon as possible.

**3.5.7** The application of the MG MOTOR Anti-Corrosion Warranty is also subject to bodywork and sub-frame repairs being carried out in accordance with MG MOTOR recommendations.

**3.5.8** The repair or replacement of components under the conditions described in the "field of application" (Paragraph 7.3), shall taken into account the general condition of the vehicle with regard to its age, mileage and maintenance level.

- 3.5.9** Parts replaced under the Anti-Corrosion Warranty legally become the property of MG MOTOR.
- 3.5.10** Repairs and components fitted under the Anti-Corrosion Warranty are guaranteed until the end of the term of the original Anticorrosion Warranty.
- 3.5.11** Transferring ownership of the vehicle does not alter the application conditions of the Anti-Corrosion Warranty.

**The MG MOTOR Paintwork Warranty:**

- 3.6 Duration of the Paintwork Warranty:** MG MOTOR guarantees the bodywork paintwork and painted parts paintwork (door mirrors, bumpers etc.) for 5 years or Unlimited kilometers (for Personal Registration) 5 years or 1.5 lac kms (for Commercial Registration) (whichever is earlier) from the Delivery Date of the new vehicle.
- 3.7 Geographical Coverage:** The geographical coverage of the

Paintwork Warranty is identical to that for the MG MOTOR New Vehicle Warranty.

**3.8 Paintwork Warranty field of application:**

- 3.8.1** This warranty covers the free repair or replacement of components with inherent paintwork defects (deterioration of lacquer or finishing varnish, due to any material, manufacturing or application defect) acknowledged by the Manufacturer, with the MG MOTOR authorized workshop carrying out the operation, keeping the Customer informed.
- 3.8.2** This repair shall take into account the general condition of the vehicle with regard to its age, mileage and maintenance level.

**3.9 The MG MOTOR Paintwork Warranty does not cover:**

- 3.9.1** any damage which is not covered by The MG MOTOR New Vehicle Warranty, as defined at the start of this booklet;

**3.9.2** damage due to force majeure events: lightning, fire, floods, earthquakes, war, riots and attacks;

**3.9.3** Mechanical components which are not an integral part of the bodywork or sub-frame (wheel rims, exhaust system, etc.).

Damage due to action of road elements (sand, gravel, dust or road debris) which results in stone chipping of paint or glass.

**3.9.4** In case, the denting or painting job has been carried out on the MG Motor Vehicle in a workshop outside the MG MOTOR authorized network.

**3.10** Paintwork Warranty conditions of application

**3.10.1** To obtain the Paintwork Warranty, the Customer must contact any workshop of the MG MOTOR Authorized Workshop Network - only such Workshop have authorization for operations of this sort.

- 3.10.2** The Customer shall show the duly completed (delivery date) Owner's Manual as proof of their entitlement to the warranty.
- 3.10.3** By way of consideration for the parts supplied by MG MOTOR under the Paintwork Warranty, parts replaced under this warranty legally become the property of MG MOTOR.
- 3.10.4** Repairs and components fitted under the Paintwork Warranty are guaranteed until the end of the term of the original Paintwork Warranty.
- 3.10.5** Transferring ownership of the vehicle does not alter the application conditions of the Paintwork Warranty.
- 4.** This warranty is the entire Warranty given by MG MOTOR and no Authorized Dealer of MG Motor or its or his agent or employee is authorized to extend or enlarge this warranty and no Authorized Dealer of MG Motor or its or his agent or employee is authorized to make any oral warranty on MG MOTOR's behalf.
- 5.** MG MOTOR reserves the right to make any change in design or make any improvement in the design, structure, technology etc. of the vehicle at any time without any obligation to make the same change on the vehicles already sold.
- 6.** Warranty service shall be provided only by MG MOTOR's Authorized Dealers and Dealer Service Branch.
- 7.** MG MOTOR's decision is final and binding on the Owner of the vehicle in all warranty matters. MG MOTOR reserves the right for the final decision on all warranty matters.
- 8.** The terms and conditions as contained herein shall be construed in accordance to the laws as applicable in India and all disputes arising out of this Warranty will be subject to the jurisdiction of Courts in Gurugram only.

## MG Roadside Assistance 24x7

**CALL 1800-100-6464**

MG Roadside Assistance is designed to enhance your overall MG ownership experience, by providing you with 24hrs/7days emergency support related to the use of your MG Motor Vehicle. Peace of mind motoring-guaranteed.

While it is our sincere hope that your travels are always trouble-free, breakdowns and road traffic accidents do happen - our goal is to ensure that even if your MG is immobilized, whether at home or while travelling, any inconvenience to you and your family is minimized.

Should you ever require assistance, all you need to do is dial our 24-hour assistance hotline: 1800 100 6464 and or press the Call button on your car and MG Roadside Assistance will be there to help. Vehicles will be covered under this program for a period of 5 years from the Date of sale of the vehicle.

### Getting Help – What to do when you need Assistance

In the event of a breakdown or accident, simply call MG Roadside Assistance on 1800 100 6464 (toll-free from anywhere in India), or press the Call button on your car. When

placing the call, please have the following information handy for assisting the operator in analysing the issue:

- Description of the problem;
- Your location;
- Registered Contact phone number, in case you are calling from a number other than your registered number, as registered with MG;
- License plate number

if you opt for your own vehicle assistance / recovery management, the cost for the same shall be borne by you.

### Covered Events

- Mechanical or electrical breakdown leading to stoppage/immobility of the vehicle
- Human error
- Key problems: locked keys, lost keys, or broken vehicle keys
- Tyre problems: puncture, bolts or valve related issues
- Battery problems: flat battery
- Fuel problems: out of fuel, incorrect fuel,

or contaminated fuel (Twice a year, up to 5 lit)

- Road traffic accident where the vehicle is immobilized

Assistance will be provided no matter where you are (i.e. at home, on the roadside, on the highway, in a parking lot, etc.), as long as you are not already at an Authorized MG Dealer.

### SUMMARY OF CUSTOMER BENEFITS

#### Roadside Assistance at home or on the road

If your vehicle is immobilized, whether at home or on the road, MG Roadside Assistance will attend to your vehicle. For conditions where we decide that the cause of the breakdown/immobilizations can be solved at the roadside, a technician will be sent to try and mobilize your vehicle at your location.

#### Vehicle Recovery

If your vehicle is unable to be mobilized following a mechanical or electrical breakdown, a recovery vehicle will be sent to recover your vehicle to the nearest authorized MG dealer.

**Taxi**

If your vehicle is recovered to an authorized MG Dealer, MG Roadside Assistance will also provide taxi assistance.

**Custody Services**

If towing is delayed, or if the technician on spot is unable to fix your vehicle, MG Roadside Assistance will arrange for a personnel to take custody of your vehicle.

**Vehicle Recovery following an Accident**

If your vehicle is unable to be mobilized following a road traffic accident, MG Roadside Assistance will organize to send a recovery vehicle to recover your vehicle from the accident site to the nearest authorized MG Dealer.

**Courtesy Car**

During such breakdown, if the repairs in the vehicle require a period of more than 24 hours, MG Roadside Assistance will aid you with a courtesy car to aid for your immobility.

**Medical Coordination**

In case of a medical assistance required by you during the breakdown, MG Roadside

Assistance team will help for the medical coordination.

**Accommodation Assistance**

In case of a breakdown occurring far from your hometown (not less than 100 kilometres), and if so needed by you, MG Roadside Assistance will help provide a hotel accommodation for you for one night.

**Program Overview –****Definitions**

- **Covered Customers:**

The owner (or driver) and all the passengers travelling in the vehicle at the moment the roadside assistance was required, up to the legal passenger limit of the vehicle. The customer may be asked to produce car/other identity documents to verify the eligibility under this Program.

- **Covered Vehicles and period of cover:**

All new MG vehicles sold by Authorised MG Dealers in India are eligible for free MG Roadside Assistance with Pan India coverage (except islands, areas with limited entries). Vehicles will be covered

under this program for a period of 5 years from the date of sale of the vehicle.

Assistance will be provided no matter where you are (i.e. at home, on the roadside, on the highways, in a parking lot, etc.), as long as you are not already at an Authorized MG Dealer.

**Non-covered Events**

MG Roadside Assistance is designed to help only in “covered events” that lead to stoppage / immobilization of your vehicle. As a result, this program will not cover following events, including but not limited to:

- Faulty fuel gauge
- Speedometer not working
- Air-conditioning is not working
- Passenger door(s) cannot be opened when there are no passengers in the vehicle
- Boot cannot be opened
- Front and / or rear demisters are not functioning
- Horn is not functioning
- Damaged door mirrors

- Rear view mirror is damaged, but it does not obstruct the driver's vision
- Damaged or faulty fuel cap but vehicle has not run out of petrol and there is enough fuel in the tank to enable the vehicle to reach the nearest Authorized MG Dealer
- Sunroof cannot be opened
- Sunroof cannot be closed but weather conditions are fair, and the vehicle is not exposed to any security risk
- Windows cannot be opened
- Windows cannot be closed but weather conditions are fair, and the vehicle is not exposed to any security risk.
- Seat adjuster is faulty, but the vehicle can be safely driven
- Passenger seat belts are faulty but there are no passengers in the vehicle
- Faulty security system unless the vehicle is immobilized or unless the alarm is sounding continuously
- ABS lights are illuminated
- Air bag warning lights are illuminated
- Traction control lights are illuminated

- Other non-safety related lights/service warnings are illuminated
- Vehicle runs out of windscreen wiper fluid
- Front or rear windscreen wipers faulty but weather conditions are fair

### General Exclusions

The following scenarios are general exclusions under the MG Roadside Assistance and therefore MG Roadside Assistance will not be responsible for any assistance costs as a result of any of the following:

- Vehicle is involved in motor racing, rallies, speed or duration tests, practice runs, or operated outside, subject to the exclusivities provided herein and in the owner manual;
- Assistance is required as a result of wars, riots, uprising, mass political demonstrations, pillage, strike, use for military purposes or acts of terrorism, earthquake damage, freak weather conditions, atmospheric phenomena, nuclear transformation phenomena or radiation caused by artificial acceleration of atomic particles;
- Breakdown is caused by deliberate damage, or participation or abetment in a criminal act or offence;
- The immobilization is resulting from damage caused by intervention of the police or other authorities;
- Any damage resulting from the use of the vehicle against the recommendations of the owner manual;
- Any consequential costs and / or damage to property as a result of a breakdown;
- Vehicles kept in a non-roadworthy condition or not serviced in accordance with the manufacturer's recommendations;
- The damage / immobilization is caused due to any repair work done on the vehicle is from a workshop which is not a member of the MG Authorised Workshop Network;
- The damage / immobilization is caused to the vehicle due to the negligence / intentional driving of the vehicle or tampering with the vehicle, even after becoming aware of the breakdown / fault / damage.



## General Terms and Conditions

### Remain with your Vehicle

- Once you have called MG Roadside Assistance, it is vital that you stay with your vehicle. Should the MG Roadside Assistance representative arrive at your vehicle while it is unattended, the necessary work will not be carried out.

### Adverse Weather

- On occasion, adverse weather conditions such as floods, heavy rain, thunder / lightning, other natural calamities or other external factors may affect our ability to provide services and it may become physically impossible to assist you until the weather improves. During such times, our main priority will be to ensure that you and your passengers are taken to a place of safety; the recovery of your vehicle may not be possible until weather conditions permit.

### External Factors

- MG will take every effort to reach you once you make the call however external conditions (including traffic, strike etc.), could delay such an effort.

### Locked Keys

- Whilst we will always endeavour to provide assistance by the most efficient method, modern security systems sometimes make it extremely difficult for us to gain entry to your vehicle at the roadside should the spare keys not be available. If a forced emergency entry is required, you will be asked to sign a declaration stating that you have granted permission for this to take place and confirming that all costs relating to any resulting damages to your vehicle will be your sole responsibility.

### Replacement Costs

- The replacement cost for any damaged part of the vehicle shall not be covered by MG Roadside Assistance, unless it is covered under any other warranty(ies) provided by MG Motor, including the new vehicle warranty, as may be applicable and / or subscribed to by the owner of the MG vehicle.

### Right of Refusal

- MG Roadside Assistance shall have the right to refuse any or all benefits under the

program, if it is found that you had furnished false information relating to your eligibility or entitlements to the benefits provided under this program.

### Disputes

- Courts situated within the jurisdiction of Gurugram alone shall have the exclusive jurisdiction to decide all disputes that may arise under this service.



## SERVICE COUPON



MORRIS GARAGES  
Since 1924

Dear Customer,

We are confident that you and your family would be enjoying the safe and comfortable drive of the MG Hector.

We would like to undertake a thorough check-up of the vehicle at 1000 kms or 30 days, whichever occurs earlier. This will also allow us to re-emphasize the salient features of the Hector to you.

**In the unlikely event of an emergency assistance, please call your nearest MG Dealer as mentioned in this booklet or please feel free to call our 24 x 7 pulse hub at 1800 100 6464**

I confirm that the vehicle has been inspected by me and delivered to my satisfaction. I do abide by MG terms & conditions laid forward for warranty and other vehicle maintenance details.

Customer's Signature

Dealer Stamp & Signature

## PDI (One day before delivery)

VIN no. \_\_\_\_\_

PDI no. \_\_\_\_\_

Date of Delivery \_\_\_\_\_

Dealer Name \_\_\_\_\_

Dealer Code \_\_\_\_\_

Customer Name \_\_\_\_\_

Contact No. \_\_\_\_\_

Customer's Signature

Dealer Stamp & Signature



SERVICE COUPON

**1<sup>st</sup> Free Inspection**

**1 Month / 1000 km (whichever occurs earlier) - Petrol**

**1 Month / 1000 km (whichever occurs earlier) - Diesel**

Engine Oil

Brake Oil / Clutch Fluid

WS Washer Fluid

Check the DTC, Diagnose, Inspect  
and Clear the all DTC

Check Fuel Lines for Leakages

Check HVAC for Satisfactory  
Performance

Check Front Brake and Rear  
Disk pad Clean-Inspect

**MG Motor Inspection**

**1<sup>st</sup> Free Inspection**

**1 Month / 1000 km (whichever occurs earlier) - Petrol**

**1 Month / 1000 km (whichever occurs earlier) - Diesel**

VIN \_\_\_\_\_

Regn. No. \_\_\_\_\_

Delivery Date \_\_\_\_\_

Date of Service \_\_\_\_\_

Kms \_\_\_\_\_

I confirm that the job has been attended to my  
satisfaction.

Customer's Signature

Dealer Stamp & Signature

Customer's Signature

Dealer Stamp & Signature

**GENERAL STATUS REVIEW**

- |                                |                          |                        |                          |
|--------------------------------|--------------------------|------------------------|--------------------------|
| Check closing efforts of doors | <input type="checkbox"/> | Central locking system | <input type="checkbox"/> |
| Other functions                | <input type="checkbox"/> |                        |                          |

**UNDER HOOD**

- |  |                          |                  |                          |
|--|--------------------------|------------------|--------------------------|
| Check fluid levels                         | <input type="checkbox"/> | Engine oil level | <input type="checkbox"/> |
| Brake oil level                            | <input type="checkbox"/> | Coolant level    | <input type="checkbox"/> |
| Power steering oil                         | <input type="checkbox"/> | M/T oil          | <input type="checkbox"/> |
| Windshield washer level & add washer fluid | <input type="checkbox"/> |                  |                          |

**UNDERBODY, WHEELS**

- |  |                          |                     |                          |
|--|--------------------------|---------------------|--------------------------|
| Visually check routing, leaks & damage | <input type="checkbox"/> | Check tyre pressure | <input type="checkbox"/> |
|--|--------------------------|---------------------|--------------------------|

**ELECTRICAL CHECKS**

- |  |                          |                                   |                          |
|--|--------------------------|-----------------------------------|--------------------------|
| Malfunction indicator lamp               | <input type="checkbox"/> | Charging lamp                     | <input type="checkbox"/> |
| Oil pressure lamp                        | <input type="checkbox"/> | Parking brake lamp / indicator    | <input type="checkbox"/> |
| High beam / Turn signal Hazard indicator | <input type="checkbox"/> | All other telltale lamp           | <input type="checkbox"/> |
| Cigarette lighter/rear defogger          | <input type="checkbox"/> | Check lighting system             | <input type="checkbox"/> |
| Horn / Radio / Outside Mirrors           | <input type="checkbox"/> | High / Low beam / Hazard signal   | <input type="checkbox"/> |
| Turn signal / Flash to pass signal       | <input type="checkbox"/> | Front/Rear fog lamps / Tail lamps | <input type="checkbox"/> |
| Stop lamp / Reversing lamp / Trunk lamp  | <input type="checkbox"/> |                                   |                          |

**DYNAMIC EVALUATION**

- |   |                          |   |                          |
|---|--------------------------|---|--------------------------|
| Steering function / noise / abnormal drag | <input type="checkbox"/> | Clutch & gear shifting function / noise | <input type="checkbox"/> |
| Accelerating & braking function / noise   | <input type="checkbox"/> | Check tyres                             | <input type="checkbox"/> |
| Any other abnormal noise                  | <input type="checkbox"/> |   |                          |

Note - For detailed information refer section 'Maintenance Schedule'.

SERVICE COUPON

**2<sup>nd</sup> Free Inspection**  
**6 Months / 5000 km (whichever occurs earlier) - Petrol**  
**6 Month / 7500 km (whichever occurs earlier) - Diesel**

- |  |                          |   |                          |
|--|--------------------------|---|--------------------------|
| Engine Oil   | <input type="checkbox"/> | Check Fuel Lines for Leakages                     | <input type="checkbox"/> |
| Air Filter Element                                     | <input type="checkbox"/> | Check HVAC for Satisfactory Performance           | <input type="checkbox"/> |
| Pollen / AC Filter                                     | <input type="checkbox"/> | Check Front Brake and Rear Disk pad-Clean-Inspect | <input type="checkbox"/> |
| Brake Oil / Clutch Fluid                               | <input type="checkbox"/> | ATF (Trans Oil)*                                  | <input type="checkbox"/> |
| WS Washer Fluid  | <input type="checkbox"/> | Check Front and Rear Brake Disk Pad-Inspect*      | <input type="checkbox"/> |
| Check the DTC, Diagnose, Inspect and Clear the all DTC | <input type="checkbox"/> |   |                          |

\*Applicable for Diesel vehicle only.

Customer's Signature

Dealer Stamp & Signature

**MG Motor Inspection**

**2<sup>nd</sup> Free Inspection**  
**6 Months / 5000 km (whichever occurs earlier) - Petrol**  
**6 Month / 7500 km (whichever occurs earlier) - Diesel**

VIN \_\_\_\_\_

Regn. No. \_\_\_\_\_

Delivery Date \_\_\_\_\_

Date of Service \_\_\_\_\_

Kms \_\_\_\_\_

I confirm that the job has been attended to my satisfaction.

Customer's Signature

Dealer Stamp & Signature

## ENGINE CONTROL SYSTEM

Drive Belt (Alternator, Power Steering and A/C Compressor)	<input type="checkbox"/>	Engine Oil	<input type="checkbox"/>
Engine Oil Filter	<input type="checkbox"/>	Cooling System Hose and Connections	<input type="checkbox"/>
Engine Coolant	<input type="checkbox"/>	Fuel Filter	<input type="checkbox"/>
Fuel Line and Connections	<input type="checkbox"/>	Air Cleaner Element	<input type="checkbox"/>
Spark Plugs & Spark Plug Wires	<input type="checkbox"/>	PCV System	<input type="checkbox"/>
EVAP Canister, Vapor Lines & Solenoid Valve Filter	<input type="checkbox"/>		

## CHASSIS AND BODY

Exhaust Pipe & Mountings	<input type="checkbox"/>	Brake Fluid	<input type="checkbox"/>
Front Brake Discs & Pads	<input type="checkbox"/>	Rear Brake Drums & Linings	<input type="checkbox"/>
Parking Brake	<input type="checkbox"/>	Brake Line and Connections (Including Booster)	<input type="checkbox"/>
Manual Transaxle Fluid	<input type="checkbox"/>	Steering Wheel & Linkage	<input type="checkbox"/>
Wheel Alignment (When required or as suggested by MG Motor retailer)	<input type="checkbox"/>	Wheel Balancing (When required or as suggested by MG Motor retailer)	<input type="checkbox"/>
Power Steering Fluid and Line	<input type="checkbox"/>	Drive Shaft Boots	<input type="checkbox"/>
Safety Belts, Buckles & Anchorages	<input type="checkbox"/>	Lubricate Locks, Hinges & Hood Latch	<input type="checkbox"/>
Tyre Condition and Inflation Pressure & Rotation	<input type="checkbox"/>	A/C Mesh Filter	<input type="checkbox"/>
Chassis and Underbody Bolts and Nuts Tight / Secure	<input type="checkbox"/>		

**Note** - For detailed information refer section 'Maintenance Schedule'.



SERVICE COUPON

**3<sup>rd</sup> Free Inspection**

**1 Year / 10000 km (whichever occurs earlier) - Petrol**

**1 Year / 15000 km (whichever occurs earlier) - Diesel**

- Engine Oil
- Oil Filter
- Washer Drain Plug
- Air Filter Element
- Spark Plug
- Pollen / AC Filter
- Brake Oil / Clutch Fluid
- Acc Belt
- Transmission Oil
- WS Washer Fluid
- Steering Geometry / Wheel  
Balancing / Rotation / Tyre  
Pressure

- Check the DTC, Diagnose,  
Inspect and Clear the  
all DTC
- Check Fuel Lines for Leakages
- Check HVAC for  
Satisfactory Performance
- Check Front Brake and Rear  
Disk pad-Clean-Inspect
- Fuel Filter\*
- Drain Water from Fuel Filter\*

\*Applicable for Diesel vehicle only.

Customer's Signature

Dealer Stamp & Signature

**MG Motor Inspection**

**3<sup>rd</sup> Free Inspection**

**1 Year / 10000 km (whichever occurs earlier) - Petrol**

**1 Year / 15000 km (whichever occurs earlier) - Diesel**

VIN \_\_\_\_\_

Regn. No. \_\_\_\_\_

Delivery Date \_\_\_\_\_

Date of Service \_\_\_\_\_

Kms \_\_\_\_\_

I confirm that the job has been attended to my satisfaction.

Customer's Signature

Dealer Stamp & Signature

### ENGINE CONTROL SYSTEM

Drive Belt (Alternator, Power Steering and A/C Compressor)	<input type="checkbox"/>	Engine Oil (Replace)	<input type="checkbox"/>
Engine Oil Filter (Replace)	<input type="checkbox"/>	Cooling System Hose and Connections	<input type="checkbox"/>
Engine Coolant	<input type="checkbox"/>	Fuel Filter	<input type="checkbox"/>
Fuel Line and Connections	<input type="checkbox"/>	Air Cleaner Element	<input type="checkbox"/>
Spark Plugs & Spark Plug Wires	<input type="checkbox"/>	PCV System	<input type="checkbox"/>
EVAP Canister, Vapor Lines & Solenoid Valve Filter	<input type="checkbox"/>		

### CHASSIS AND BODY

Exhaust Pipe & Mountings	<input type="checkbox"/>	Brake Fluid	<input type="checkbox"/>
Front Brake Discs & Pads	<input type="checkbox"/>	Rear Brake Drums & Linings	<input type="checkbox"/>
Parking Brake	<input type="checkbox"/>	Brake Line and Connections (Including Booster)	<input type="checkbox"/>
Manual Transaxle Fluid	<input type="checkbox"/>	Steering Wheel & Linkage	<input type="checkbox"/>
Wheel Alignment (When required or as suggested by MG Motor retailer)	<input type="checkbox"/>	Wheel Balancing (When required or as suggested by MG Motor retailer)	<input type="checkbox"/>
Power Steering Fluid and Line	<input type="checkbox"/>	Drive Shaft Boots	<input type="checkbox"/>
Safety Belts, Buckles & Anchorages	<input type="checkbox"/>	Lubricate Locks, Hinges & Hood Latch	<input type="checkbox"/>
Tyre Condition and Inflation Pressure & Rotation	<input type="checkbox"/>	A/C Mesh Filter	<input type="checkbox"/>
Chassis and Underbody Bolts and Nuts Tight / Secure	<input type="checkbox"/>		

**Note** - For detailed information refer section 'Maintenance Schedule'.

SERVICE COUPON

**4th Free Inspection**

**2 Years / 20000 km (whichever occurs earlier) - Petrol**

**2 Years / 30000 km (whichever occurs earlier) - Diesel**

- |  |                          |  |                          |
|--|--------------------------|--|--------------------------|
| Engine Oil   | <input type="checkbox"/> | Check the DTC, Diagnose, Inspect and Clear the all DTC | <input type="checkbox"/> |
| Oil Filter   | <input type="checkbox"/> |  |                          |
| Fuel Filter  | <input type="checkbox"/> | Check Fuel Lines for Leakages                          | <input type="checkbox"/> |
| Washer Drain Plug  | <input type="checkbox"/> | Check HVAC for Satisfactory Performance                | <input type="checkbox"/> |
| Air Filter Element   | <input type="checkbox"/> |  |                          |
| Spark Plug   | <input type="checkbox"/> | Check front Brake and Rear Disk pad-Clean-Inspect      | <input type="checkbox"/> |
| Pollen / AC Filter   | <input type="checkbox"/> | Transmission Oil*                                      | <input type="checkbox"/> |
| Brake Oil / Clutch Fluid                                       | <input type="checkbox"/> | ATF (Trans Oil)*                                       | <input type="checkbox"/> |
| Acc Belt   | <input type="checkbox"/> | Drain Water from fuel filter*                          | <input type="checkbox"/> |
| WS Washer Fluid  | <input type="checkbox"/> |  |                          |
| Steering Geometry / Wheel Balancing / Rotation / Tyre Pressure | <input type="checkbox"/> |  |                          |

\*Applicable for Diesel vehicle only.

Customer's Signature

Dealer stamp & signature

**MG Motor Inspection**

**4th Free Inspection**

**2 Years / 20000 km (whichever occurs earlier) - Petrol**

**2 Years / 30000 km (whichever occurs earlier) - Diesel**

VIN \_\_\_\_\_

Regn. No. \_\_\_\_\_

Delivery date \_\_\_\_\_

Date of service \_\_\_\_\_

Kms \_\_\_\_\_

I confirm that the job has been attended to my satisfaction.

Customer's Signature

Dealer Stamp & Signature

### ENGINE CONTROL SYSTEM

Drive Belt (Alternator, Power Steering and A/C Compressor)	<input type="checkbox"/>	Engine Oil (Replace)	<input type="checkbox"/>
Engine Oil Filter (Replace)	<input type="checkbox"/>	Cooling System Hose and Connections	<input type="checkbox"/>
Engine Coolant	<input type="checkbox"/>	Fuel Filter	<input type="checkbox"/>
Fuel Line and Connections	<input type="checkbox"/>	Air Cleaner Element	<input type="checkbox"/>
Spark Plugs & Spark Plug Wires	<input type="checkbox"/>	PCV System	<input type="checkbox"/>
EVAP Canister, Vapor Lines & Solenoid Valve Filter	<input type="checkbox"/>		

### CHASSIS AND BODY

Exhaust Pipe & Mountings	<input type="checkbox"/>	Brake Fluid	<input type="checkbox"/>
Front Brake Discs & Pads	<input type="checkbox"/>	Rear Brake Drums & Linings	<input type="checkbox"/>
Parking Brake	<input type="checkbox"/>	Brake Line and Connections (Including Booster)	<input type="checkbox"/>
Manual Transaxle Fluid	<input type="checkbox"/>	Steering Wheel & Linkage	<input type="checkbox"/>
Wheel Alignment (When required or as suggested by MG Motor retailer)	<input type="checkbox"/>	Wheel Balancing (When required or as suggested by MG Motor retailer)	<input type="checkbox"/>
Power Steering Fluid and Line	<input type="checkbox"/>	Drive Shaft Boots	<input type="checkbox"/>
Safety Belts, Buckles & Anchorages	<input type="checkbox"/>	Lubricate Locks, Hinges & Hood Latch	<input type="checkbox"/>
Tire Condition and Inflation Pressure & Rotation	<input type="checkbox"/>	A/C Mesh Filter	<input type="checkbox"/>
Chassis and Underbody Bolts and Nuts Tight / Secure	<input type="checkbox"/>		

Note - For detailed information refer section 'Maintenance Schedule'.

SERVICE COUPON

**5th Free Inspection**

**3 Years / 30000 km (whichever occurs earlier) - Petrol**

**3 Years / 45000 km (whichever occurs earlier) - Diesel**

- Engine Oil
- Oil Filter
- Washer Drain Plug
- Air Filter Element
- Spark Plug
- Pollen / AC Filter
- Brake Oil / Clutch Fluid
- Acc Belt
- WS Washer Fluid
- Steering Geometry / Wheel  
Balancing / Rotation / Tyre  
Pressure

- Check the DTC, Diagnose,  
Inspect and Clear the  
all DTC
- Check fuel lines for Leakages
- Check HVAC  
for Satisfactory Performance
- Check front Brake and Rear  
Disk pad-Clean-Inspect
- Fuel Filter\*
- Drain Water from fuel filter\*

\*Applicable for Diesel vehicle only.

Customer's Signature

Dealer stamp & signature

**MG Motor Inspection**

**5th Free Inspection**

**3 Years / 30000 km (whichever occurs earlier) - Petrol**

**3 Years / 45000 km (whichever occurs earlier) - Diesel**

VIN \_\_\_\_\_

Regn. No. \_\_\_\_\_

Delivery date \_\_\_\_\_

Date of service \_\_\_\_\_

Kms \_\_\_\_\_

I confirm that the job has been attended to my satisfaction.

Customer's Signature

Dealer Stamp & Signature

### ENGINE CONTROL SYSTEM

Drive Belt (Alternator, Power Steering and A/C Compressor)	<input type="checkbox"/>	Engine Oil (Replace)	<input type="checkbox"/>
Engine Oil Filter (Replace)	<input type="checkbox"/>	Cooling System Hose and Connections	<input type="checkbox"/>
Engine Coolant	<input type="checkbox"/>	Fuel Filter	<input type="checkbox"/>
Fuel Line and Connections	<input type="checkbox"/>	Air Cleaner Element	<input type="checkbox"/>
Spark Plugs & Spark Plug Wires	<input type="checkbox"/>	PCV System	<input type="checkbox"/>
EVAP Canister, Vapor Lines & Solenoid Valve Filter	<input type="checkbox"/>		

### CHASSIS AND BODY

Exhaust Pipe & Mountings	<input type="checkbox"/>	Brake Fluid	<input type="checkbox"/>
Front Brake Discs & Pads	<input type="checkbox"/>	Rear Brake Drums & Linings	<input type="checkbox"/>
Parking Brake	<input type="checkbox"/>	Brake Line and Connections (Including Booster)	<input type="checkbox"/>
Manual Transaxle Fluid	<input type="checkbox"/>	Steering Wheel & Linkage	<input type="checkbox"/>
Wheel Alignment (When required or as suggested by MG Motor retailer.)	<input type="checkbox"/>	Wheel Balancing (When required or as suggested by MG Motor retailer.)	<input type="checkbox"/>
Power Steering Fluid and Line	<input type="checkbox"/>	Drive Shaft Boots	<input type="checkbox"/>
Safety Belts, Buckles & Anchorages	<input type="checkbox"/>	Lubricate Locks, Hinges & Hood Latch	<input type="checkbox"/>
Tyre Condition and Inflation Pressure & Rotation	<input type="checkbox"/>	A/C Mesh Filter	<input type="checkbox"/>
Chassis and Underbody Bolts and Nuts Tight / Secure	<input type="checkbox"/>		

Note - For detailed information refer section 'Maintenance Schedule'.

**Change of Ownership Record**

Model \_\_\_\_\_

Registration or  
License Number | | | | | | | | | | | | | | | | | | | | | |

VIN \_\_\_\_\_

New Owner's Name \_\_\_\_\_

New Owner's Address \_\_\_\_\_  
\_\_\_\_\_  
\_\_\_\_\_  
\_\_\_\_\_

Telephone No. \_\_\_\_\_

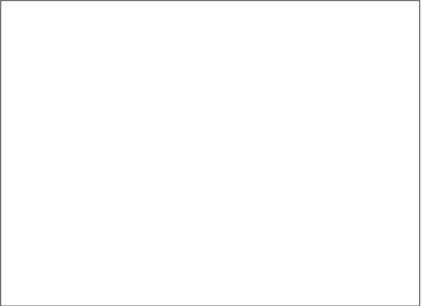

If resold by MG Motor Dealership  
Enter Dealer Stamp in Box above

## MAINTENANCE INTERVAL

### Periodic Maintenance Schedule - Petrol Manual Transmission and Hybrid Vehicles

Years		1 Month	6 Months	1 Year	2 Year	3 Year	4 Year	5 Year	6 Year	7 Year	8 Year	9 Year	10 Year
Operation / Processes for Periodic Service Schedule	Replacement Frequency: Km / Year whichever is earlier	1000	5000	10000	20000	30000	40000	50000	60000	70000	80000	90000	100000
Engine Oil	10K/1 Year	I	I	R	R	R	R	R	R	R	R	R	R
Oil Filter	10K/1 Year			R	R	R	R	R	R	R	R	R	R
Fuel Filter	20K/2 Years			R	R				R		R		R
Washer Drain Plug	10K/1 Year			R	R	R	R	R	R	R	R	R	R
Air Filter Element	20K/2 Years		I	I	R	I	R	I	R	I	R	I	R
Spark Plug	30K/3 Years			I	I	R	I	I	R	I	I	R	I
Pollen / AC Filter	10K/1 Year		I	R	R	R	R	R	R	R	R	R	R
Brake Oil / Clutch Fluid	30K/3 Years	I	I	I	I	R	I	I	R	I	I	R	I
Acc Belt	100K			I	I	I	I	I	I	I	I	I	I
Timing Chain	NA												I
Transmission Oil	60K/5 Years			I		I			R				I
Coolant Change (7.0 Lt)	80K/8 Years	I	I	I	I	I	I	I	I	I	R	I	I
WS Washer Fluid	10K/1 Year	I	I	R	R	R	R	R	R	R	R	R	R
Steering Geometry / Wheel Balancing / Rotation / Tyre Pressure	10K/1 Year			I	I	I	I	I	I	I	I	I	I
Check the DTC, Diagnos, Inspect and clear the all DTC	10K/1 Year	I	I	I	I	I	I	I	I	I	I	I	I
Check Fuel lines for Leakages	Every Service	I	I	I	I	I	I	I	I	I	I	I	I
Check HVAC for Satisfactory Performance	Every Service	I	I	I	I	I	I	I	I	I	I	I	I
Check front Brake and Rear Disk pad-Clean-Inspect	Every Service	I	I	I	I	I	I	I	I	I	I	I	I

**Symbol Abbreviation:** **R** -Replace • **I** - Inspect (Top up if required/Adjust/Clean/Gap setting/Clean) • **NA**: Not applicable • \* Labour Free Services.

- Tightening of underbody fasteners, door adjustments and functional checks of all the systems during every service is mandatory.

- Check the coolant level and top up as required, replace if it is contaminated/ discoloured or there is sludge formation.

- Filters, Fluid, Diesel Exhaust Fluid (DEF), Consumables, Components, Wheel Alignment, Wheel Balancing etc. (but not limited to mentioned) will be replaced on **chargeable basis**.



**Periodic Maintenance Schedule - Petrol Automatic Transmission**

Years		1 Month	6 Months	1 Year	2 Year	3 Year	4 Year	5 Year	6 Year	7 Year	8 Year	9 Year	10 Year
Operation / Processes for Periodic Service Schedule	Replacement Frequency: Km / Year whichever is earlier	1000	5000	10000	20000	30000	40000	50000	60000	70000	80000	90000	100000
Engine Oil	10K/1 Year	I	I	R	R	R	R	R	R	R	R	R	R
Oil Filter	10K/1 Year			R	R	R	R	R	R	R	R	R	R
Fuel Filter	20K/2 Years			R	R	R	R	R	R	R	R	R	R
Washer Drain Plug	10K/1 Year			R	R	R	R	R	R	R	R	R	R
Air Filter Element	20K/2 Years		I	I	R	I	R	I	R	I	R	I	R
Spark Plug	30K/3 Years			I	I	R	I	I	R	I	I	R	I
Pollen / AC Filter	10K/1 Year		I	R	R	R	R	R	R	R	R	R	R
Brake Oil /Clutch Fluid	30K/3 Years	I	I	I	I	R	I	I	R	I	I	R	I
Acc Belt	100K			I	I	I	I	I	I	I	I	I	I
Timing Chain	NA												I
Coolant Change (7.0 Lt)	80K/8 Years	I	I	I	I	I	I	I	I	I	R	I	I
WS Washer Fluid	10K/1 Year	I	I	R	R	R	R	R	R	R	R	R	R
ATF (Trans Oil DCT)#	60K/5 Years					I			R			I	
CVT Oil (Shell 2100)#	50K/5 Years			I		I		R			I		R
Steering Geometry / Wheel Balancing/ Rotation / Tyre Pressure	10K/1 Year			I	I	I	I	I	I	I	I	I	I
Check the DTC, Diagnos, Inspect and clear the all DTC	10K/1 Year	I	I	I	I	I	I	I	I	I	I	I	I
Check fuel lines for Leakages	Every Service	I	I	I	I	I	I	I	I	I	I	I	I
Check HVAC for Satisfactory Performance	Every Service	I	I	I	I	I	I	I	I	I	I	I	I
Check front Brake and Rear Disk pad-Clean-Inspect	Every Service	I	I	I	I	I	I	I	I	I	I	I	I

**Symbol Abbreviation:** R -Replace • I - Inspect (Top up if required/Adjust/Clean/Gap setting/Clean) • NA: Not applicable • \* Labour Free Services.

- Tightening of underbody fasteners, door adjustments and functional checks of all the systems during every service is mandatory.

- Check the coolant level and top up as required, replace if it is contaminated/ discoloured or there is sludge formation.

- Filters, Fluid, Diesel Exhaust Fluid (DEF), Consumables, Components, Wheel Alignment, Wheel Balancing etc. (but not limited to mentioned) will be replaced on **chargeable basis**.

# Depending on vehicle transmission.

## MAINTENANCE INTERVAL

### Periodic Maintenance Schedule - Diesel Manual Transmission

Years		1 Month	6 Months	1 Year	2 Year	3 Year	4 Year	5 Year	6 Year	7 Year	
Operation / Processes for Periodic Service Schedule	Replacement Frequency: Km / Yr whichever is earlier	1000*	7500*	15000*	30000*	45000*	60000	75000	90000	105000	
Engine Oil	15K/1 Year	I	I	R	R	R	R	R	R	R	
Oil Filter	15K/1 Year			R	R	R	R	R	R	R	
Fuel Filter	15K/1 Year			R	R	R	R	R	R	R	
Washer Drain Plug	15K/1 Year			R	R	R	R	R	R	R	
Air Filter Element	15K/1 Year		I	R	R	R	R	R	R	R	
Pollen / AC Filter	15K/1 Year		I	R	R	R	R	R	R	R	
Brake Oil / Clutch Fluid	45K/3 Years	I	I	I	I	R	I	I	R	I	
Acc Belt	75K			I	I	I	I	R	I	I	
Timing Belt + Roller	75K							I			
Transmission Oil	60K/5 Years				I		R		I		
Coolant Change	75K/5 Years	I	I	I	I	I	I	R	I	I	
WS Washer Fluid	15K/1 Year	I	I	R	R	R	R	R	R	R	
Steering Geometry / Wheel Balancing/Rotation/Tyre Pressure	15K/1 Year			I	I	I	I	I	I	I	
Drain Water from Fuel Filter	15K/1 Year			I	I	I	I	I	I	I	
Check the DTC, Diagnos, Inspect and clear the all DTC	Every Service	I		I	I	I	I	I	I	I	
Check fuel lines for Leakages	Every Service	I	I	I	I	I	I	I	I	I	
Check HVAC for Satisfactory Performance	Every Service	I	I	I	I	I	I	I	I	I	
Check Front and Rear Brake Disk Pad-Inspect	Every Service	I	I	I	I	I	I	I	I	I	
<b>Topping of Diesel Exhaust Fluid (DEF) (Not a part of Periodic Maintenance Schedule)</b>				<b>7500</b>	<b>15000</b>	<b>30000</b>	<b>45000</b>	<b>60000</b>	<b>75000</b>	<b>90000</b>	<b>105000</b>
Check and, if necessary, top-up additive for emission reduction (Diesel Exhaust Fluid (DEF) (For more information regarding top-up, please refer page no. 164 Diesel Exhaust Fluid (DEF) section)				I	I	I	I	I	I	I	I

**Symbol Abbreviation :** R - Replace • I - Inspect (Top up if required/Adjust/Clean/Gap setting/Clean) • NA: Not applicable \* \* Labour Free Services.

- Tightening of underbody fasteners, door adjustments and functional checks of all the systems during every service is mandatory.

- Check the coolant level and top up as required, replace if it is contaminated/ discoloured or there is sludge formation.

- Filters, Fluid, Diesel Exhaust Fluid (DEF), Consumables, Components, Wheel Alignment, Wheel Balancing etc. (but not limited to mentioned) will be replaced on **chargeable basis**.





**ANDHRA PRADESH**

**VIJAYAWADA**

**Sri Jayalakshmi Automotives Pvt. Ltd.**

- 3S** I-136/3, Gudavalli Junction, NH16,  
Rural Mandal - 521104

**VISAKHAPATNAM**

**Tristar Auto Agencies Pvt. Ltd.**

- IS** Tristar Auto, Behind Kali Mata Mandir, RK  
Beach Junction, Vishakhapatnam - 530002
- 2S** Tristar Auto, Plot D 36, Industrial Estate,  
Marripalem, Visakhapatnam - 530002

**BIHAR**

**PATNA**

**Ashiana Fabicon Pvt. Ltd.**

- IS** Ground Floor, "Ashiana Vihar" Apartment,  
Near CDA Building, Rajendra Path,  
Patna - 800 001
- 2S** Anisabad Main, Patna - 800 002

**CHHATISGARH**

**RAIPUR**

**Shivaaya Cars Pvt. Ltd.**

- 3S** Ring Road No.1, Raipura, Raipur - 492013

**DELHI NCR**

**MG Cars Pvt. Ltd.**

- IS** Plot No 13, Shivaji Marg, New Delhi - 110015
- 2S** 7/20, Block-B, Kirti Nagar Industrial Area,  
New Delhi - 110015
- EC** Outer Ring Road, Block C 2, Sector 14,  
Rohini, New Delhi - 110085

**Sai Shreeja Cars Pvt. Ltd.**

- IS** A-2/5, Safdarjung Enclave - 110029
- 2S** B-67, Phase-1, Okhla Industrial Area,  
New Delhi - 110020
- EC** A-14, Ring Road, Lajpat Nagar-IV,  
New Delhi - 110024

**Cargo Motors (Kutch) Pvt. Ltd.**

- IS** Sector 15 Part 2, Gurugram - 122022
- 2S** Sector 74A, Gurugram - 122004
- 3S** I4/6, Mathura Road, Pocket B, Sector 27,  
Faridabad - 121003
- EC** MGF Metropolis, Sector 28, Gurugram

**Crystal Autocars Pvt. Ltd.**

- 3S** D-2, Sector 8, Noida - 201301
- EC** Plot No. 24, Patparganj  
Industrial Area, New Delhi - 110092
- EC** Block G, Patel Nagar 3, Patel Nagar,  
Ghaziabad - 201003

**GOA**

**Priority Auto Lincs Pvt. Ltd.**

- IS** Survey No.166/1, New Taleigao Bypass Road,  
Opp. Taleigao Community Centre - 403002
- 2S** Survey No.132/1-C, Behind Healthway  
Hospital, SE Old Goa, Tiswadi - 403108

**GUJARAT**

**AHMEDABAD**

**Concept Motor Garage Pvt. Ltd.**

- IS** Ground Floor, Signature I, Near YMCA Club,  
S.G. Highway, Ahmedabad - 380051
- 2S** Survey No. 321, Sanathal, S.P. Ring Road,  
Ahmedabad - 404000
- EC** Neelkanth Square, NH-8, Naroda,  
Ahmedabad - 382330

**RAJKOT**

**Jai Ganesh Autocars Pvt. Ltd.**

- IS** Shri Balvi House Revenue Survey No. 215,  
Opp. Krishna Park, National Highway,  
Kothariya, Rajkot - 360003
- 2S** Near Jagannath Marble, Rajkot Gondal  
Highway, Kothariya, Rajkot - 360003

**SURAT**

**Nanavati Autosquare Pvt. Ltd.**

- 1S** Ground Floor, Icon Business Centre, Opposite Central Mall, Piplod Dumas Road, Surat - 395007
- 2S** Bhatpore GIDC, Behind Nanavati Toyota, Magdala Hazira Road, Surat - 394510

**VADODARA**

**Kayakalp Cars Pvt. Ltd.**

- 1S** Zorba, Akshara Chowk, OP Road, Vadodara
- 2S** 362 GIDC Makarpura, Vadodara - 390010

**HARYANA**

**KARNAL**

**Rahul Automotives Pvt. Ltd.**

- 3S** Adjoining Sudhanshu ji Maharaj Ashram, Near Devi Lal Chowk, Karnal

**JAMMU & KASHMIR**

**JAMMU**

**Arise Autoz Pvt. Ltd.**

- 1S** Malik Market, Bypass Jammu - 180016
- 2S** Malik Market, Bypass Jammu - 180016

**JHARKHAND**

**RANCHI**

**Singhania Future Pvt. Ltd.**

- 1S** Near Firayalals Pulsar Plaza, Line Tank Road, Ranchi - 834001
- 2S** NH-33, Chakla, Ormanjhi, Ranchi - 835219

**KARNATAKA**

**BENGALURU (West + South)**

**Jubilant Motorworks Pvt. Ltd.**

- 1S** 195/6/2, Ward No. 192, Beratena Agrahara, Luv Kusha Nagar, Hosur Road, Bangalore - 560100
- 2S** Audi-Workshop, 6/1, Beratena Agrahara, Hosur Main Road, Electronic City, Bangalore - 560100
- EC** Shree Bhuvanewari Vokkaligara Sangha, Survey No 102-1, B Narayanapura, ORR, Bangalore - 560016
- EC** Axis One4, No. 14, 15th Cross, JP Nagar 4th Phase, Bangalore - 560078

**BENGALURU (North + East)**

**Jubilant Motorworks Pvt. Ltd.**

- 1S** Big Boy Toyz - No. 144, Chikkathayappa Reddy Layout, 1st Cross, Chelekere Village, Outer Ring Road, Kalyan Nagar Post, Bangalore - 560043

- 2S** MVIT Workshop - Survey No. 32/33, Nellakunte Village, Jala Hobli, Yelahanka Taluk, MVIT College Road, Hunasemaranahalli Post, Bangalore - 562157
- EC** #84 Old No. 32, 20th Main West of Chord Road, Rajaj ji Nagar, Bangalore - 560010

**MYSORE**

**Dyuthi Automobiles Pvt. Ltd.**

- 3S** Plot No. 201/1&2, Hunsur Road, Mysore - 570017

**KERALA**

**COCHIN**

**Coastline Garages India Pvt. Ltd.**

- 1S** Parammal, Kozhikode
- 2S** Peringave-Parammal Road, Parammal, Ramanattukara - 673632
- 3S** Near Toll Plaza, Salem - Kochi - Kanyakumari Hwy, Thalavanikkara, Paliyekkara, Chittisery - 680301
- 3S** Survey No. 452/2; NH47, Kalamaserry, Cochin - 682022

**TRIVANDRUM**

**Pothen Autoworld Pvt. Ltd.**

- 3S** KJ Square, TC -55/719/1, Kaimanam, Karmana, Trivandrum - 695040

**MADHYA PRADESH**

**BHOPAL**

**Hriday Cars Pvt. Ltd.**

**IS** Khasra No. 59, P.H.No-20, Ward No-54,  
Hosangabaad Road, Ahamadpur,  
Bhopal - 462001

**2S** NH 12, Indus Towne, Ratanpur Sadak,  
Bhopal - 462047

**INDORE**

**Hriday Cars Pvt. Ltd.**

**IS** I-Anoop Nagar, AB Road, Indore - 452018

**2S** SR Compound, Indore - 453771

**MAHARASHTRA**

**MUMBAI**

**Kishiv Auto Agencies Pvt. Ltd.**

**IS** Cynergy IT Park, Appa Saheb Marathe Marg,  
Prabhadevi, Mumbai - 400025

**3S** Jogeshwari Caves Road, Gupha Tekdi,  
Western Express Highway Jogeshwari East,  
Mumbai - 400060

**EC** 106/G, B wing, Express Zone, Western  
Express Highway, Malad - East, Mumbai

**THANE**

**Tejpal Motors Pvt. Ltd.**

**IS** Shop No. 16, Dosti Imperia, Ghodbunder  
Road, Thane West, Thane - 400607

**2S** Western Extrusion Industries,  
Near Capital Hotel, Thane West - 400606

**EC** Old Mahindra Showroom, Next to AutoBahn  
VW Showroom

**KOLHAPUR**

**Unique Automobiles Pvt. Ltd.**

**IS** S.No. 592, H.No 4481, 1st Stop MIDC Shirol  
(P) Tal-Hatkanangale, Dist-Kolhapur - 416122

**2S** C/O-Choughle Machines Pvt. Ltd., A-17/18,  
MIDC, Shirol, Kolhapur - 416122

**NASHIK**

**Jitendra Wheels (N) Pvt. Ltd.**

**IS** B-88, MIDC Ambad, Patherdi Bridge, Next  
to Taj Residency, Nashik - 422001

**2S** P-11/2, Ambad MIDC, near Volkswagen  
Showroom, opp Lokmat Office, Mumbai Agra  
Highway, Nasik-422010

**AURANGABAD**

**Dhoot Autotech Pvt. Ltd.**

**IS** ABC Complex, Adalat Road, Chintamani  
Colony, Aurangabad - 431005

**2S** Adalat Road, Next to High Court, Samadhan  
Colony, Konkanwadi, Aurangabad - 431005

**PUNE**

**B.U Bhandari Auto Pvt. Ltd.**

**3S** Survey No. 142, Hissa No. 1+2/5, Wakad,  
Mumbai Bangalore Highway, Pune - 411057

**EC** Parakh House, Boat Club (Liberty phase 2,  
Bund Garden, Sangamvadi), Pune - 411001

**NAGPUR**

**Nangia Automotive Pvt. Ltd.**

**3S** Plot No B-33-1/4, Ring Road, MIDC, Nagpur

**ODISHA**

**BHUBANESWAR**

**Empreo Wheels Pvt. Ltd.**

**3S** Plot No. 86/88, Near Apex Institute of  
Technology & Management, Pahala, NH-16,  
Bhubaneswar - 752101

**PUNJAB**

**LUDHIANA**

**Gitansh Motors Pvt. Ltd.**

**3S** GT Road Jugiana, Adjoining Indian Oil Petrol  
Pump, Ludhiana - 141010

**JALANDHAR**

**Cargo Motors (Kutch) Pvt. Ltd.**

**3S** BSF Chowk, G.T. Road, Jalandhar - 144001

**CHANDIGARH**

**Krishna Motor Garage**

**IS** 178, MW Area, Industrial Area Phase I,  
Chandigarh - 160002

**MOHALI**

**3S** Plot No. 3, Sector 82, Mohali - 160055

**IS** - Sales

**2S** - Service + Spares

**3S** - Sales + Service + Spares

**EC** - Experience Centre

**RAJASTHAN**

**JAIPUR**

**GPS Automobiles Pvt. Ltd.**

- IS** Plot No. 2&3/4, Choudhary Charan Singh Colony, Tonk Road, Jaipur - 302029
- 2S** G-221 Sitapura Industrial Area, Sitapura, Jaipur - 302022
- EC** Near Bajaj Capital, G-3, Anukampa Tower, Church Road (M.I. Road), Gopalbari, Jaipur

**JODHPUR**

**Ganpati Four Wheels Pvt. Ltd.**

- 3S** Plot No.18, Opp. Saras Dairy, Heavy Industrial Area, Jodhpur - 342003

**UDAIPUR**

**Chambal Motors Pvt. Ltd.**

- 3S** CP-6/CP-7, Madri Industrial Area, Udaipur

**TAMILNADU**

**CHENNAI**

**FPL Automobiles Pvt. Ltd.**

- IS** No. 398, Anna Salai, CIT Nagar - 600035
- 2S** Poly Container Industries, Developed Plot No. 5, South Phase, Thiru Vi Ka Industrial Estate, Guindy, Chennai - 600032
- EC** Cenza Technologies Pvt. Ltd., Plot New No. 4, Old No. 8, Developed Plot, Industrial Estate for Electrical, Electronics and Instruments Industries, Perungudi, Chennai - 600097

**TELANGANA**

**HYDERABAD**

**RAAM4WHEELERS LLP**

- IS** 8-2-120/86/10, 10A, 11B, 11C and 11D, Opp. Hotel Park Hyatt, Road Number 2, Banjara Hills, Hyderabad - 500033

**SECUNDERABAD**

- 2S** H. No. 7-8-188/3, Gautam Nagar, Balanagar, Secunderabad - 500011

**RAI DURG**

- EC** 7-56/19, Dargah Road, Radhe Nagar, GachiBowli, Rai Durg

**UTTAR PRADESH**

**AGRA**

**NRL Cars Pvt. Ltd.**

- 3S** 404, Nagla Padi, Near Arvind Hyundai, Agra - 282005

**KANPUR**

**SOCMO Cars Pvt. Ltd.**

- IS** 15/63, Rudra House, Civil Lines, Kanpur - 208001
- 2S** 12/483, Macrobertganj, Kanpur - 208002

**LUCKNOW**

**Beeaar Autowheels India Pvt. Ltd.**

- 3S** Milestone No. 111, Faizabad Road, Chinhat, Lucknow - 227105
- EC** 10, Ashok Marg, Near Shri Ram Tower, Sadullah Nagar, Narhi, Hazratganj, Lucknow - 226001

**VARANASI**

**Puneet Cars Sales Pvt. Ltd.**

- IS** Andhrapull, Chaukaghat, Varanasi - 221002
- 2S** Grand Trunk Road, Parao, Varanasi - 221002

**UTTARAKHAND**

**DEHRADUN**

**Grand Automobiles Pvt. Ltd.**

- 3S** Saharanpur Road, Mahobewala Chowk, Dehradun - 248002

**WEST BENGAL**

**KOLKATA**

**Auto Hi-Tech Pvt. Ltd.**

- IS** 97A Southern Avenue, Kolkata - 700039
- 2S** 34A, C.N. Roy Road, Kolkata - 700039
- EC** Ecocentre Ambuja Neotia, EM Block, Sector V, Salt Lake City, Kolkata - 700091

**IS** - Sales

**2S** - Service + Spares

**3S** - Sales + Service + Spares

**EC** - Experience Centre



# VEHICLE RECORD SHEET

<b>MODEL</b>																
<b>CHASSIS NO.</b>																
<b>ENGINE NO.</b>																
<b>KEY NO.</b>																
<b>DATE OF DELIVERY</b>																
<b>MILEAGE (KM)</b>																
<b>BATTERY</b>	MAKE					SR NO./ BATCH CODE										
<b>TYRE</b>	TYRE LOCATION			FR RH <input type="checkbox"/>		FR LH <input type="checkbox"/>		RR RH <input type="checkbox"/>		RR LH <input type="checkbox"/>						
	MAKE					BATCH NUMBER										

<b>OWNER'S NAME &amp; ADDRESS:</b>

**ADDRESS OF SELLING DEALER**

Showroom:
Workshop:

For any feedback, please call **Toll free No. 1800 100 6464**

**www.mgmotor.co.in**  
**1800 100 6464**

**MG Motor India Pvt. Ltd.**

All information, illustrations and specifications contained in this Owner's Manual are based on the latest production information available at the time of publication. The right is reserved to make changes at any time without notice.

Version: 05-02/2020/4000 (2021)

