

John Lewis

Instruction manual
Pump espresso coffee machine



Contents

- 3 Important safety information
- 6 Your Pump espresso coffee machine - diagram
- 7 Before first use
- 8 Preheating
- 8 Making espresso
- 9 Making cappuccino
- 10 Steam for heating or frothing milk
- 10 Cleaning and maintenance
- 11 Descaling the coffee machine
- 12 Troubleshooting
- 13 Technical specifications
- 13 Servicing and disposal
- 14 Guarantee

Important safety information

Thank you for purchasing this Pump espresso coffee machine.

Please read the instructions and warnings carefully to ensure a long life for your product and safe usage. This instruction leaflet must be retained with the appliance for future reference. These warnings have been provided in the interest of safety. You **MUST** read them carefully before using the appliance.

If you are unsure of the meaning of any of these warnings, please contact your nearest John Lewis & Partners shop or John Lewis & Partners Technical Support on 03301 230106.

This product is not intended for use by persons (including children) with reduced physical, sensory or mental capabilities, unless they are properly supervised or given instructions concerning the safe use of the item by a person responsible for their wellbeing. Children must not play with the appliance. Cleaning and maintenance should not be carried out by children.

- Unplug from the mains when not in use, when removing or attaching accessories and before cleaning any part of the appliance.
- Do not place the coffee machine on hot surfaces or near sources of heat.
- Do not immerse the cord, plug or unit in water or other liquids.
- Do not operate any appliance with a damaged cord or plug. Should the item malfunction, or if it is damaged in any manner, please stop using it and return it to your nearest John Lewis & Partners shop. Do not attempt to repair it yourself. Do not modify the appliance's plug.
- Do not let the power cord overhang the edge of the surface on which it stands, or touch anything hot. Do not allow the power cord to touch the hot surfaces of the coffee machine.
- When unplugging the device, hold the plug itself, not the power cord.
- Do not use the appliance for any purpose other than its intended use.
- This appliance is for indoor use only. Do not use it outdoors.
- Do not use accessories or attachments that

- are not recommended by the manufacturer.
- This coffee machine is for household and light commercial use.
- Do not operate the coffee machine without water.
- Do not remove the portafilter during brewing or steaming.
- Do not touch the hot surface of the appliance, the steam wand or filter basket. Be careful: steam can scald skin.



WARNING: Polythene bags over the product or within packaging may be dangerous. To avoid the risk of suffocation, please keep away from pets, babies and children.

Your coffee machine - diagram

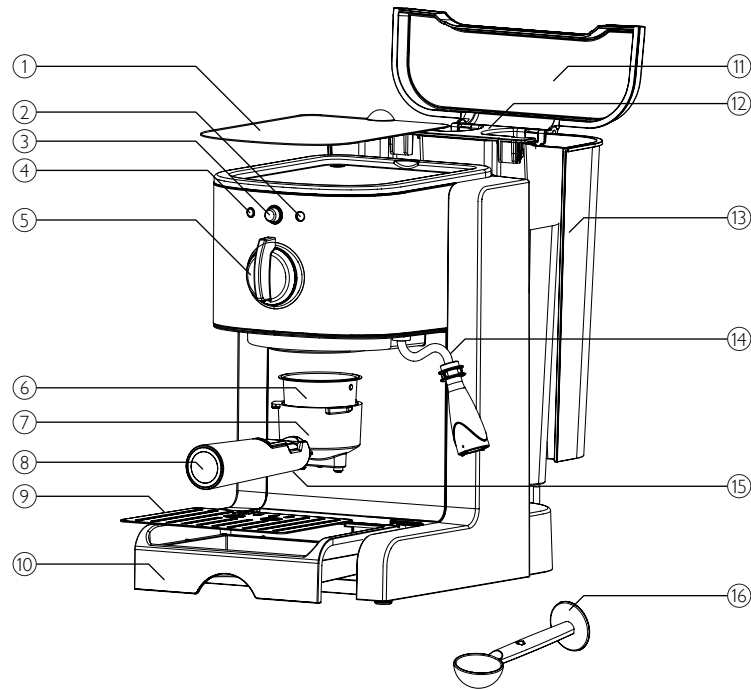

Diagram key

- | | |
|---------------------|------------------------------|
| ① Cup warming plate | ⑨ Removable cup shelf |
| ② Reading indicator | ⑩ Drip tray |
| ③ ON/OFF button | ⑪ Tank cover |
| ④ Power indicator | ⑫ Handle |
| ⑤ Coffee/steam knob | ⑬ Detachable tank |
| ⑥ Filter basket | ⑭ Steam wand |
| ⑦ Portafilter | ⑮ Press bar |
| ⑧ Funnel handle | ⑯ Measuring spoon and tamper |

This coffee machine comes with two filter baskets.
One for a single shot the other a double shot.

Before first use

1. Pour water into the water tank and close the lid. The water level should not exceed the maximum fill mark. Note: the coffee machine's tank is detachable for easy filling and cleaning.
2. Fit the filter basket into the portafilter. Fit the portafilter into the appliance in the Insert position. Fix it into the machine by turning it anti-clockwise until it locks (see Diagram 1).
3. Place an espresso cup on the removable cup shelf. Ensure that the Coffee/Steam dial is in the "●" position. Note: the appliance is not supplied with espresso cups.
4. Plug in the coffee machine and press the On/Off switch to get started. The orange indicator light will come on to indicate that the water is being heated.
5. When the green indicator light comes on, the heating stage is complete. Turn the Coffee/Steam dial to the "☺" position, and hot water will flow out.
6. After about one minute, turn the Coffee/Steam dial to the "●" position to end the brewing process. Pour out the unused water and rinse out the appliance. Now you are ready to begin brewing.



Note: The machine may make a noise when pumping out water for the first time. This is normal. The appliance is working out the air in its system. The noise will end after 20 seconds.

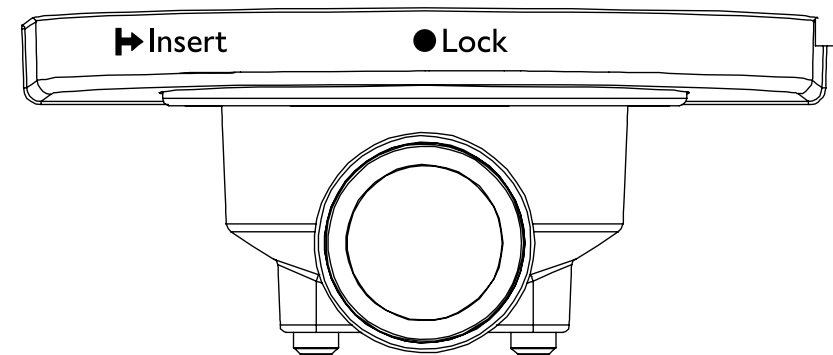

Diagram 1

Preheating

Preheat the appliance, including the portafilter, filter basket and cup, for the best flavour.

1. Remove the detachable tank. Open the tank cover to fill it with water. The water level should not exceed the maximum fill mark in the tank. Fit the tank back into the coffee machine.
2. Fit the filter basket properly into the portafilter. Insert the portafilter into the appliance in the Insert position. Fix it into the machine by turning it anti-clockwise until it locks (see Diagram 1).
3. Place an espresso cup on the removable cup shelf.
4. Plug in the appliance. Make sure the Coffee/Steam dial is in the '●' position.
5. Turn the machine on. The orange indicator light will come on to indicate that the water is being heated.
6. When the green indicator light comes on, turn the Coffee/Steam dial to the '☺' position. Hot water will flow out. After a minute, turn the Coffee/Steam dial again to the '●' position. The pre-heating stage is complete.

Making espresso

1. Remove the portafilter by turning it clockwise. Place the filter basket in the portafilter. Add coffee to the filter basket with a measuring spoon. A spoonful of ground coffee will make about one cup. Flatten the coffee down with the tamper.
2. Insert the portafilter into the appliance in the Insert position. Fix it into the machine by turning it anti-clockwise until it locks (see Diagram 1).
3. Pour out the hot water in the cup. Place the hot cup on the removable cup shelf.
4. When the green indicator light comes on, you should turn the Coffee/Steam dial to the '☺' position. Coffee will begin to pour.



Note: During the brewing or steam-making process, the green light will go out. This is normal and indicates that the coffee is sufficiently hot. The heater will now keep the temperature at the correct level.

5. When you have your desired amount of coffee, or when the coffee changes colour is and becoming weak, the power indicator and ready indicators will go out. Your coffee is ready.



WARNING: Do not leave the coffee machine unattended while it is operating.

6. After finishing making coffee, take the portafilter out by turning it clockwise. Empty out the coffee residue.
7. Let the accessories cool down completely, then rinse them under running water.

Making cappuccino

Cappuccino is made by adding frothed milk to a cup of espresso.



Note: during steam making, the portafilter must be properly in place.

1. First, prepare the espresso according to the instructions above.
2. Turn the Coffee/Steam dial to the '●' position. Wait for the green indicator light to come on.
3. Fill a jug with approximately 100 grams of milk for each cappuccino to be prepared. Whole milk, straight from the fridge is recommended.



Note: Choose a jug with a diameter of 65 to 75mm. Bear in mind that the milk volume will double, so please ensure that the jug is tall enough.

4. Insert the wand's plastic sleeve into the milk at a depth of about two centimetres. Turn the Coffee/Steam dial to the '☺' position. Steam will be released from the steam outlet. Froth the milk by moving the jug gently around.



Caution! Operate carefully as steam can scald skin.

5. When the milk is frothed, turn the Coffee/Steam dial to the '●' position (see Diagram 2).

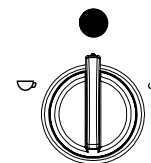

Diagram 2



Note: Clean the steam outlet with a damp cloth as soon as it has cooled.

6. Pour the frothed milk into the espresso. Your cappuccino is ready. Sprinkle with cocoa powder if desired.
7. Turn off the machine off.



Note: Drip plate and tray, Filter is dishwasher safe.

Steam for heating or frothing milk

The steam wand can be used to froth milk or to make hot beverages like drinking chocolate or tea.

Method:

1. Remove the detachable tank and fill it with the required amount of water. The water level should not exceed the maximum fill mark in the tank. Fit the tank back into the appliance.
2. Plug the coffee machine in.
3. Turn the machine on. The orange indicator light will come on.
4. Turning the Coffee/Steam dial to the "●" position. The appliance will heat up. When the green indicator light comes on, it shows that the heating is stage is complete.
5. Dip the plastic sleeve of the steam wand into the liquid to be heated or the milk to be frothed. Turn the Coffee/Steam dial to the "☞" position to start making steam.
6. When your beverage is hot enough or your milk is sufficiently frothed, turn the Coffee/Steam dial to the "●" position.
7. Turn the machine off.

Cleaning and maintenance

1. Turn the machine off at the plug and allow the coffee machine to cool down completely before cleaning.
2. Wipe down the coffee machine's housing with a damp cloth. Ensure you regularly clean and dry the water tank, drip tray and removable shelf.



Note: Do not clean with alcohol or a solvent. Use a mild detergent only. Never immerse the housing in water to clean it.

3. Detach the portafilter by turning it clockwise, removing the coffee residue inside, then cleaning and rinsing it.
4. Clean and dry all of the coffee machine's accessories.

Descaling the coffee machine

1. To make sure your coffee machine is operating efficiently and the coffee tastes as good as it can, you should descale the machine every 2-3 months.
2. Fill the tank with water and descaler to the maximum fill level (use a 4:1 ratio of water to descaler). As an alternative to a household descaler, you can use a very weak solution of citric acid (one hundred parts of water to three parts of citric acid).
3. Follow the pre-heating programme. Fit the portafilter and jug without adding coffee.
4. Turn the machine on. The orange indicator light will come on. Ensure the Coffee/Steam dial is in the "●" position. Wait for the coffee machine to heat up.
5. When the green indicator light comes on, heating is complete. Turn the Coffee/Steam dial to the "☞" position and make two cups of coffee (about 2oz). Then turn the Coffee/Steam dial to the "●" position and wait for five seconds.
6. Once the green indicator light comes on, make steam for two minutes, then turn the Coffee/Steam dial to the "●" position to finish. Turn the machine off. Let the descaler sit in the machine for 15 minutes.
7. Repeat steps 4 - 6 twice.
8. Turn the Coffee/Steam dial to the "●" position. When the green light comes on, turn the Coffee/Steam dial to the "☞" position and let it brew until the machine is empty.
9. To rinse out the machine, run it again with water. Do not add coffee. Fill the tank with tap water to the maximum fill level and repeat steps 4 - 6 twice. You do not need to let water sit in the machine as you did with the descaler.

Troubleshooting

Problem	Cause	Solution
Water is leaking from the bottom of the coffee machine.	There is too much water in the drip tray.	Empty the drip tray.
	The coffee machine has malfunctioned.	Please return the coffee machine to John Lewis & Partners.
Water is leaking from the outside of the filter.	There is ground coffee on the filter edge.	Wipe away any stray grounds.
The espresso has an acidic, vinegary taste.	The machine has not been properly descaled.	Perform a complete clean of the machine as you would before first use. Descale it thoroughly.
	The coffee powder has been stored in a damp or warm place.	Please use fresh coffee powder. Store unused coffee powder in a cool, dry place. After opening a package of coffee powder, reseal it tightly and store it in the fridge to maintain its freshness.
The coffee machine is not responding at all.	The coffee machine is not properly connected to a power outlet.	Ensure the power cord is plugged in correctly. If this does not work, please contact John Lewis & Partners Technical Support on 03301 230106.
The milk is not frothing.	The green indicator light is not illuminated.	Wait until the green indicator light comes on.
	The container is too large or the shape is unsuitable.	Use a high, narrow jug.
	You are using skimmed milk.	You must use whole or semi-skimmed milk.
Water droplets around water tank upon open product	Water residue may be left following a flush cycle in production.	This is normal. Rinse the product before use

Technical specifications

Rated input: 220-240V ~ 50Hz
Output: 1250 - 1470W

Capacity: 1.25L detachable water tank

Servicing and disposal

This product should only be repaired or serviced by an authorised service engineer. Only genuine, approved spare parts should be used.

This symbol  indicates that this product should not be treated as normal household waste and should be recycled. John Lewis does not operate in-store take back, but as a member of the Distributor Take Back scheme has funded the development and upgrade of recycling facilities across the UK.

Please take your old appliance to your nearest collection facility. For further details, contact your local council or visit: www.recycle-more.co.uk

Guarantee

This item is guaranteed for two years in respect of defects found to be due to faulty workmanship or materials. Proof of purchase is required for the validity of the guarantee. This guarantee is no longer valid in the case of accidental damage, alteration, repair by any unauthorised persons or poor maintenance. This guarantee in no way affects your statutory rights.

Please retain these instructions for future use.



John Lewis Partnership
171 Victoria Street
London SW1E 5NN
johnlewis.com