

Rosemount™ 3051N Smart Pressure Transmitter for Nuclear Service

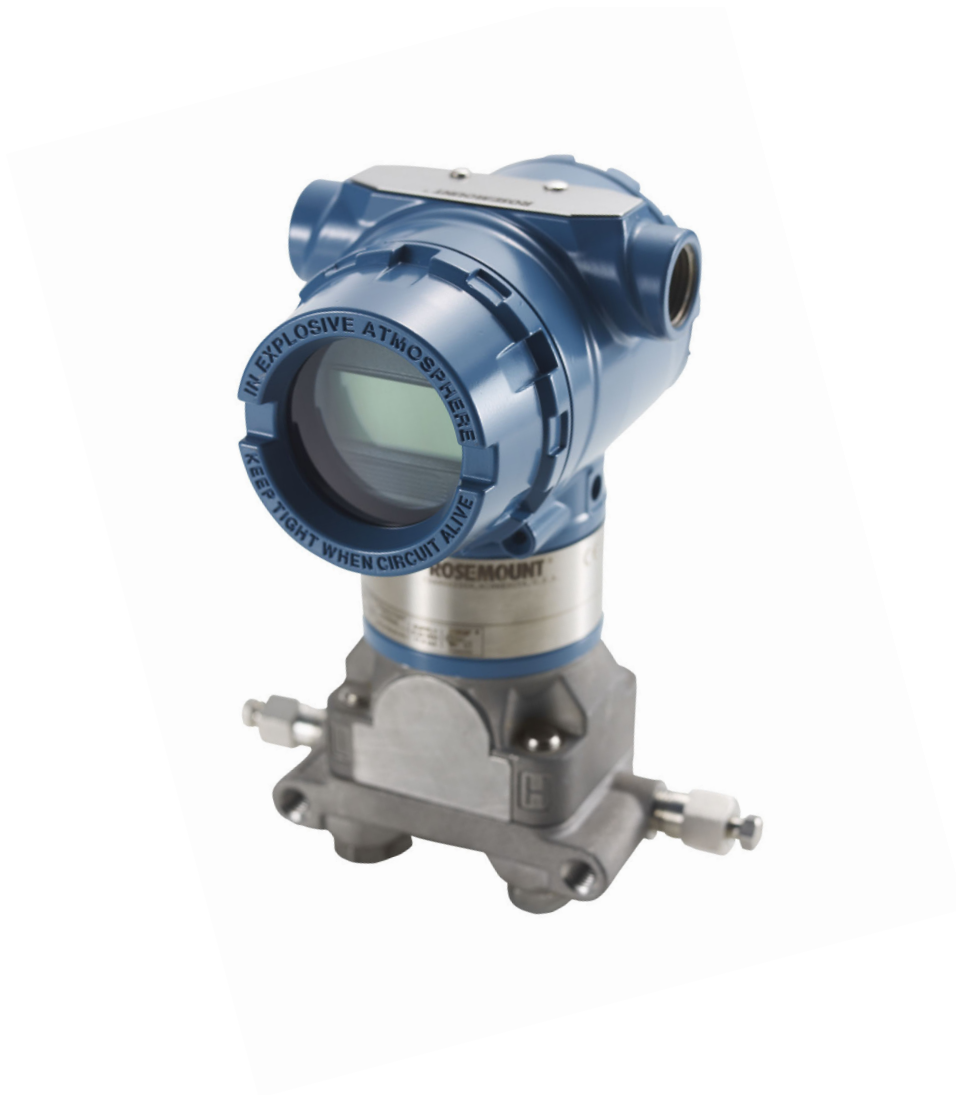

CE

This page intentionally left blank

Section 1: Introduction

1.1 Using this manual	1
-----------------------------	---

Section 2: Transmitter Functions

2.1 Overview	3
2.2 Safety messages	3
2.3 Failure mode alarm	4
2.3.1 Alarm level verification	4
2.4 Transmitter security	4
2.4.1 Security jumper (write protect)	5
2.4.2 Local zero and span (local keys) software lock out	5
2.4.3 Physical removal of local zero and span (local keys)	5
2.5 Configuring transmitter alarm and security jumper	5
2.6 Commissioning transmitter with a HART-based communicator	6
2.6.1 Setting the loop to manual	6
2.6.2 Wiring diagrams (bench hook-up)	7
2.6.3 Wiring diagrams (field hook-up)	7
2.7 Review configuration data	8
2.8 Check output	9
2.8.1 Process variables	9
2.8.2 Sensor temperature	9
2.9 Basic setup	9
2.9.1 Set process variable units	9
2.9.2 Set output	10
2.9.3 Rerange	10
2.9.4 Rerange with a communicator only	11
2.9.5 Rerange with a pressure input source and a communicator	11
2.9.6 Rerange with a pressure input source and the local zero and span buttons	11
2.9.7 Damping	12
2.9.8 LCD display meter options	13
2.10 Detailed setup	13
2.10.1 Local span and zero control (local keys)	13
2.10.2 Sensor temperature output unit selection	13
2.11 Diagnostics and service	13
2.11.1 Transmitter test	14
2.11.2 Loop test	14
2.12 Calibration	15
2.12.1 Calibration overview	16

2.12.2	Deciding which trim procedure to use	17
2.12.3	Sensor trim	18
2.12.4	Zero trim	18
2.12.5	Full trim	19
2.12.6	Recall factory trim	20
2.12.7	Recall factory trim— sensor trim	20
2.12.8	Recall factory trim— analog output	20
2.12.9	Analog output trim	20
2.12.10	Digital-to-analog trim	21
2.12.11	Digital-to-analog trim using other scale	21
2.12.12	Compensating Rosemount 3051N Range 4 and 5 Differential Transmitters for line pressure	22

Section 3: Installation

3.1	Overview	25
3.2	Safety messages	25
3.3	General considerations	27
3.3.1	Special draft range considerations	27
3.4	Mechanical considerations	27
3.4.1	Rosemount 3051ND0 and 3051ND1	27
3.4.2	Steam service	28
3.4.3	Side mounting	28
3.4.4	Independent seals	28
3.4.5	Mounting	31
3.4.6	Process connections	34
3.4.7	Housing rotation	34
3.5	Electrical considerations	34
3.5.1	Power supply	34
3.5.2	Wiring	35
3.5.3	Grounding the transmitter case	36
3.6	Environmental considerations	36
3.6.1	Access requirements	36
3.6.2	Cover installation	37

Section 4: Troubleshooting

4.1	Overview	39
4.2	Safety messages	39
4.2.1	Returning Rosemount products and materials	40

Appendix A: Specifications and Reference Data

A.1	Nuclear specifications	41
A.1.1	Seismic	41
A.1.2	Environmental	41
A.1.3	Quality Assurance program	41
A.1.4	Nuclear cleaning	41
A.1.5	Hydrostatic testing	42
A.2	Performance specifications	42
A.2.1	Reference accuracy	42
A.2.2	Drift	42
A.2.3	Ambient temperature effect ⁽¹⁾	42
A.2.4	Overpressure effect	42
A.2.5	Static pressure effect	43
A.2.6	Power supply effect	43
A.2.7	Load effect	43
A.2.8	Mounting position effect	43
A.3	Functional specifications	43
A.3.1	Service	43
A.3.2	Output	43
A.3.3	Power supply	43
A.3.4	Temperature limits	43
A.3.5	Span and zero, zero elevation, and suppression	44
A.3.6	Humidity limits	44
A.3.7	Volumetric displacement	44
A.3.8	Turn-on time	44
A.3.9	Response time	44
A.3.10	Maximum working pressure	45
A.3.11	Static pressure limits	45
A.3.12	Overpressure limits	45
A.3.13	Burst pressure	45
A.4	Physical specifications	45
A.4.1	Materials of construction	45
A.5	Ordering information	47
A.6	Configuration information	48
A.6.1	Rosemount 3051N 4-20 mA/HART Output Smart Pressure Transmitters Typical Configuration Data Worksheet	49

Appendix B: Options

B.1 Overview	51
B.2 Safety messages	51
B.3 LCD display meter	51
B.3.1 Custom meter configuration	52
B.3.2 Installing the meter	53
B.3.3 Diagnostic messages	54
B.3.4 Warnings	55
B.3.5 Operation	56
B.4 Mounting brackets	56
B.4.1 Traditional flange (H2)	57
B.5 Transient protection terminal block (T1)	57

Appendix C: HART® Communicator

C.1 Introduction	61
C.2 Safety messages	62
C.3 Connections and hardware	65
C.4 Menus and functions	67
C.4.1 Main menu	67
C.4.2 Online menu	68
C.4.3 Fast Key sequences	68
C.4.4 Hot Key options	68
C.5 Diagnostic messages	69

Appendix D: Glossary.....71

Rosemount™ 3051N Smart Pressure Transmitter for nuclear service

Rosemount 3051 HART® Universal Revision 5

⚠ WARNING

Read this manual before working with the product. For personal and system safety, and for optimum product performance, make sure you thoroughly understand the contents before installing, using, or maintaining this product.

Within the United States, contact Rosemount Nuclear Instruments, Inc. at 1-952-949-5200 for assistance.

Outside of the United States, contact your local Emerson Process Management Sales Representative.

Rosemount Nuclear Instruments, Inc. warranty and limitations of remedy

The warranty and limitations of remedy applicable to this Rosemount equipment are as stated on the reverse of the current Rosemount quotation and customer acknowledgment forms.

Return of material

Authorization for return is required from Rosemount Nuclear Instruments, Inc. prior to shipment. Contact Rosemount Nuclear Instruments, Inc. (1-952-949-5200) for details on obtaining Return Material Authorization (RMA). Rosemount Nuclear Instruments will not accept any returned material without a Returned Material Authorization. Material returned without authorization is subject to return to customer.

Material returned for repair, whether in or out of warranty, should be shipped prepaid to:

Rosemount Nuclear Instruments, Inc.

8200 Market Blvd.

Chanhassen, MN 55317

USA

Important

The Rosemount 3051N Pressure Transmitter is qualified for nuclear use per IEEE Std 344-1987 and IEEE Std 323-1983 (mild environment) as documented in Rosemount Report D2001019, and is supplied in accordance with 10CFR50 Appendix B and ISO 9001:2008 quality assurance programs. To ensure compliance with 10CFR Part 21, the transmitter must comply with the requirements herein and in Report D2001019 throughout its installation, operation, and maintenance. It is incumbent upon the user to ensure that the Rosemount Nuclear Instruments, Inc. component traceability program where applicable is continued throughout the life of the transmitter.

Where the manual uses the terms requirements, mandatory, must, or required, the instructions so referenced must be carefully followed. Rosemount Nuclear Instruments, Inc. expressly disclaims all responsibility and liability for transmitters for which the foregoing has not been complied with by the user.

This page intentionally left blank

Section 1 Introduction

1.1 Using this manual

The sections in this manual provide information on installing, operating, and maintaining devices from the Rosemount™ 3051N Smart Pressure Transmitter Family. The sections are organized as follows:

[Section 2: Transmitter Functions](#) provides instruction on commissioning and operating Rosemount 3051N Pressure Transmitters. Information on software functions, configuration parameters, and online variables is also included.

[Section 3: Installation](#) provides mechanical and electrical installation instructions.

[Section 4: Troubleshooting](#) provides troubleshooting techniques for the most common Rosemount 3051N Transmitter operating problems.

[Appendix A: Specifications and Reference Data](#) provides reference and specification data for the Rosemount 3051N Smart Pressure Transmitter Family.

[Appendix B: Options](#) describes the mounting and configuration options available for Rosemount 3051N Transmitters.

[Appendix C: HART® Communicator](#) provides an overview of the HART Communicator, defines its partial command menu tree for the Rosemount 3051N Family, and provides a table of typical Fast Key sequences. A table of typical diagnostic messages is also included.

This page intentionally left blank

Section 2 Transmitter Functions

Overview	page 3
Safety messages	page 3
Failure mode alarm	page 4
Transmitter security	page 4
Configuring transmitter alarm and security jumper	page 5
Commissioning transmitter with a HART-based communicator	page 6
Review configuration data	page 8
Check output	page 9
Basic setup	page 9
Detailed setup	page 13
Diagnostics and service	page 13
Calibration	page 15

2.1 Overview

This section contains information on commissioning and operating Rosemount™ 3051N Smart Pressure Transmitters. Tasks that should be performed on the bench prior to installation are explained in this section.

When the HART® Communicator is referenced, it refers to the 275, 375, or 475 Field Communicator as documented in Rosemount Report D2001019.

For your convenience, typical HART Communicator Fast Key sequences are listed for most software functions. These Fast Key sequences are the same for the 275, 375, and 475 Field Communicators. If you are unfamiliar with the communicator or how to follow Fast Key sequences, refer to [Appendix C: HART® Communicator](#) for communicator operations.

A typical transmitter software configuration data worksheet is provided in [Appendix A: Specifications and Reference Data](#).

2.2 Safety messages

Procedures and instructions in this section may require special precautions to ensure the safety of the personnel performing the operations. Information that raises potential safety issues is indicated by a warning symbol (⚠). Refer to the following safety messages before performing an operation preceded by this symbol.

⚠ WARNING

Explosions can result in death or serious injury.

- Do not remove the transmitter covers in explosive environments when the circuit is alive.

Electrical shock can result in death or serious injury.

- Avoid contact with the leads and terminals. High voltage that may be present on leads can cause electrical shock.
-

2.3 Failure mode alarm

Rosemount 3051N Transmitters automatically and continuously perform self-diagnostic routines. If the self-diagnostic routines detect a failure, the transmitter drives its output outside of the normal saturation values. The transmitter will drive its output low or high based on the position of the failure mode alarm jumper. See [Table 2-1](#) for failure mode and saturation output levels. To select alarm position, see “[Configuring transmitter alarm and security jumper](#)” on [page 5](#).

Table 2-1. Standard Alarm and Saturation Values

Level	4–20 mA Saturation	4–20 mA Alarm
Low	3.9 mA	≤ 3.75 mA
High	20.8 mA	≥ 21.75 mA

Note

The actual transmitter mA output values can be altered by performing an analog output trim.

Note

When a transmitter is in an alarm condition, the hand-held HART Communicator indicates the analog output the transmitter would drive if the alarm condition did not exist. The transmitter will alarm high in the event of failure if the alarm jumper is removed.

2.3.1 Alarm level verification

Transmitters allow verification testing of alarm current levels. If you replace the LCD display meter, reconfigure or make any changes to the transmitter, verify the transmitter alarm level before you return the transmitter to service. This feature is also useful in testing the reaction of your control system to a transmitter in an alarm state. To verify the transmitter alarm values, perform a loop test and set the transmitter output to the alarm value (see [Table 2-1](#) and “[Loop test](#)” on [page 14](#)).

2.4 Transmitter security

There are three security methods with the Rosemount 3051N Transmitter.

1. Security Jumper: prevents all writes to transmitter configuration.
2. Local Keys (Local Zero and Span) Software Lock Out: prevents changes to transmitter range points via local zero and span adjustment keys. With local keys security enabled, changes to configuration are possible via HART.
3. Physical Removal of Local Keys (Local Zero and Span) Magnetic Buttons: removes ability to use local keys to make transmitter range point adjustments. With local keys security enabled, changes to configuration are possible via HART.

Note

If the security jumper is not installed, the transmitter will continue to operate in the security OFF configuration.

2.4.1 Security jumper (write protect)

You can prevent changes to the transmitter configuration data with the write protection jumper. Security is controlled by the security (write protect) jumper located on the electronics board or meter face. Position the jumper on the transmitter circuit board in the *ON* position to prevent accidental or deliberate change of configuration data.

If the transmitter write protection jumper is in the *ON* position, the transmitter will not accept any “writes” to its memory. Configuration changes, such as digital trim and reranging, cannot take place when the transmitter security is on.

2.4.2 Local zero and span (local keys) software lock out

To enable this feature, see “Local span and zero control (local keys)” on page 13.

2.4.3 Physical removal of local zero and span (local keys)

To remove the magnetic buttons used to activate the local zero and span, use a small slotted head screwdriver and pry off the small, plastic cap located under the approval tag. Remove button assemblies and discard.

2.5 Configuring transmitter alarm and security jumper

To reposition the jumpers, follow the procedure described below.

1. If the transmitter is installed, secure the loop and remove power.
2. Remove the housing cover opposite the field terminal side. Do not remove the transmitter covers in explosive atmospheres when the circuit is alive.
3. Reposition the jumpers as desired.
 - Figure 2-1 shows the jumper positions for electronics boards.
 - Figure 2-2 shows transmitters with an optional LCD display meter.
4. Reattach the transmitter cover. Transmitter covers must be fully engaged to meet explosionproof requirements.

Figure 2-1. Electronics Board

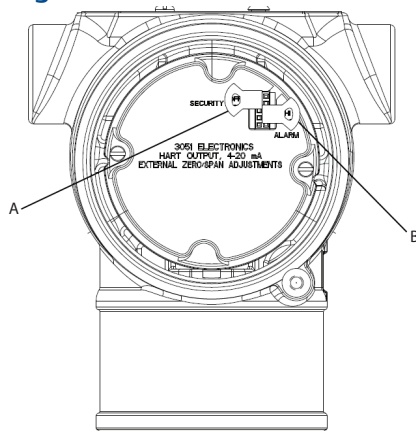

A. Security
B. Alarm

Figure 2-2. Rosemount 3051N Transmitter with Optional LCD Display Meter



Note

Security jumper not installed = not write protected
Alarm jumper not installed = high alarm

2.6 Commissioning transmitter with a HART-based communicator

Commissioning consists of testing the transmitter and verifying transmitter configuration data. You may commission Rosemount 3051N Transmitters either before or after installation. Commissioning the transmitter on the bench before installation using a HART-based Communicator ensures that all transmitter components are in good working order and acquaints you with the operation of the device.



To commission on the bench, connect the transmitter and the communicator as shown in Figure 2-3. Make sure the instruments in the loop are installed in accordance with intrinsically safe or nonincendive field wiring practices before connecting a communicator in an explosive atmosphere. Connect the communicator leads at any termination point in the signal loop. It is most convenient to connect them to the terminals labeled “COMM” on the terminal block. Connecting across the “TEST” terminals will prevent successful communication. To avoid exposing the transmitter electronics to the plant environment after installation, set all transmitter jumpers during the commissioning stage on the bench.

For 4–20 mA transmitters, you will need a power supply capable of providing 10.5 to 55 V dc at the transmitter, and a meter to measure output current. To enable communication, a resistance of at least 250 ohms, but within the transmitter load limitations (see Figure 3-7 on page 35) must be present between the communicator loop connection and the power supply. Do not use inductive-based transient protectors with the Rosemount 3051N Transmitter.

2.6.1 Setting the loop to manual

Whenever you are preparing to send or request data that would disrupt the loop or change the output of the transmitter, you must set your process application loop to manual. The HART Communicator will prompt you to set the loop to manual when necessary. Keep in mind that acknowledging this prompt does not set the loop to manual. The prompt is only a reminder; you have to set the loop to manual yourself as a separate operation.

2.6.2 Wiring diagrams (bench hook-up)

Connect the bench equipment as shown in [Figure 2-3](#) and turn on the HART-based Communicator by pressing the ON/OFF key. The communicator will search for a HART-compatible device and will indicate when the connection is made. If the communicator fails to connect, it will indicate that no device was found. If this occurs, refer to [Section 4: Troubleshooting](#).

Figure 2-3. Bench Hook-up (4–20 mA Transmitters)

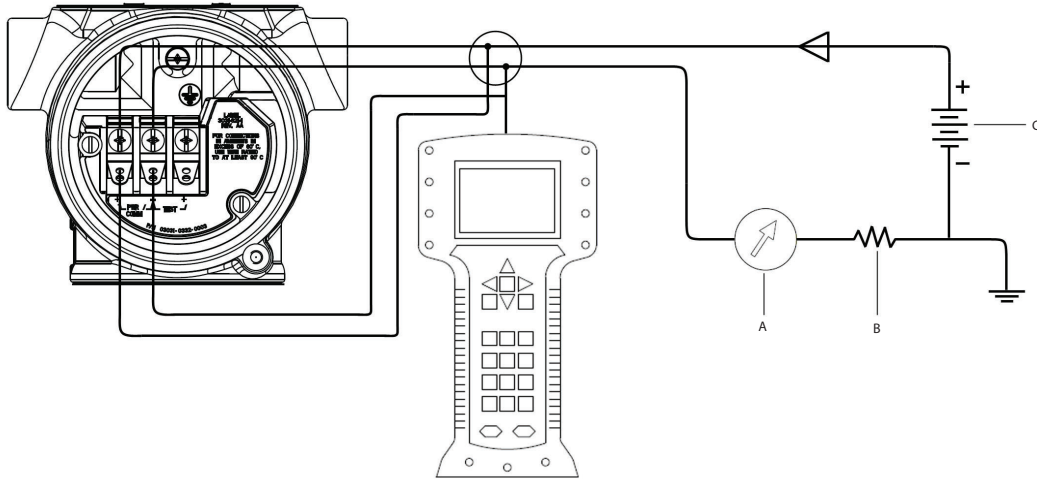

- A. Current meter
 - B. $R_t \geq 250$ ohms (necessary for HART communication only)
 - C. 24 Vdc power supply
- See "Safety messages" on page 3 for warning information.



2.6.3 Wiring diagrams (field hook-up)

The following diagrams illustrate wiring loops for a field hook-up with a HART-based Communicator.

Figure 2-4. Field Hook-up (4–20 mA Transmitters)

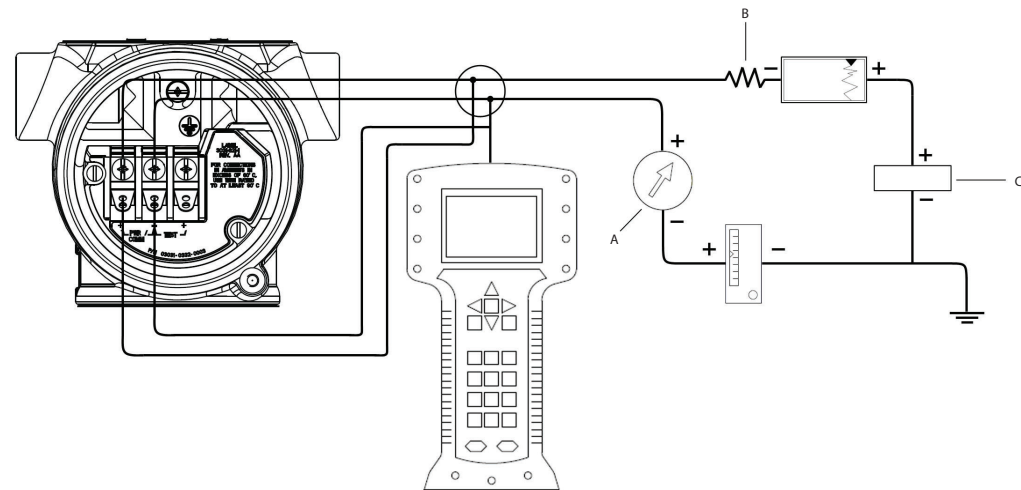

- A. Current meter
- B. $R_t \geq 250$ ohms (necessary for HART communication only)
- C. Power supply

⚠ CAUTION

Do not use inductive-based transient protectors.

Note

Signal point may be grounded at any point or left ungrounded

2.7 Review configuration data

HART Fast Keys	1, 5
-----------------------	------

Note

Information and procedures in this section that make use of HART Communicator Fast Key sequences assume that the transmitter and communicator are connected, powered, and operating correctly. Refer to [Appendix C: HART® Communicator](#) for more details on the HART Communicator or Fast Key sequences.

Before placing the transmitter into operation, it is recommended to review the transmitter configuration data that was set at the factory. Review the following configuration data:

Transmitter Model	Type
Tag	Range
Date	Descriptor
Message	Minimum and Maximum Sensor Limits
Minimum Span	Units
4 and 20 mA points	Output (linear or sq. root)
Damping	Alarm Setting (high, low)
Security Setting (on, off)	Local Zero/Span Keys (enabled, disabled)
Integral Meter	Sensor Fill
Isolator Material	Flange (type, material)
O-Ring Material	Drain/Vent
Remote Seal (type, fill fluid, isolator material, number)	Transmitter S/N
Address	Sensor S/N

2.8 Check output

Before performing other transmitter online operations, review the digital output parameters to ensure that the transmitter is operating properly and is configured to the appropriate process variables.

2.8.1 Process variables

HART Fast Keys	2
-----------------------	---

The process variables for the Rosemount 3051N Transmitter provide the transmitter output, and are continuously updated. The process variable menu displays the following process variables:

- Pressure
- Percent of Range
- Analog Output

The pressure reading in both Engineering Units and Percent of Range will continue to track with pressures outside of the defined range from the lower to the upper range limit of the sensor module.

Note

Regardless of the range points, the Rosemount 3051N Transmitter will measure and report all readings within the digital limits of the sensor. For example, if the 4 and 20 mA points are set to 0 and 10 in H₂O on a range code 1 Rosemount 3051N Transmitter, and the transmitter detects a pressure of 25 inH₂O, it digitally outputs the 25 inH₂O reading and a 250% of span reading. However, there may be up to ±5.0% error associated with output outside of the range points.

2.8.2 Sensor temperature

HART Fast Keys	1, 1, 4
-----------------------	---------

The Rosemount 3051N Transmitter contains a temperature sensor just above its pressure sensor in the sensor module. When reading this temperature, keep in mind that this is not a process temperature reading.

2.9 Basic setup

2.9.1 Set process variable units

HART Fast Keys	1, 3, 2
-----------------------	---------

The *PV Unit* command sets the process variable units to allow you to monitor your process using the appropriate units of measure. Select from the following engineering units:

- | | | | |
|----------------------|------------------------------|----------------------|------------------------------|
| ■ inH ₂ O | ■ mmHg | ■ bar | ■ Pa |
| ■ inHg | ■ psi | ■ mbar | ■ kPa |
| ■ ftH ₂ O | ■ torr | ■ g/cm ² | ■ atm |
| ■ mmH ₂ O | ■ inH ₂ O at 4 °C | ■ kg/cm ² | ■ mmH ₂ O at 4 °C |

2.9.2 Set output

HART Fast Keys	1, 3, 5
-----------------------	---------

Activate the transmitter square root output option to make the analog output proportional to flow. As the input approaches zero, the Rosemount 3051N Transmitter automatically switches to a linear output in order to ensure a more smooth, stable output near zero. See [Figure 2-5](#).

The transition from linear to square root is not adjustable. It occurs at 0.8 percent of ranged pressure input or 8.9 percent of full-scale flow output.

From 0 percent to 0.6 percent of the ranged pressure input, the slope of the curve is unity ($y = x$). This allows accurate calibration near zero. Greater slopes would cause large changes in output for small changes at input. From 0.6 percent to 0.8 percent, the slope of the curve equals 42 ($y = 42x$) to achieve continuous transition from linear to square root at the transition point.

Figure 2-5. Square Root Output Transition Point

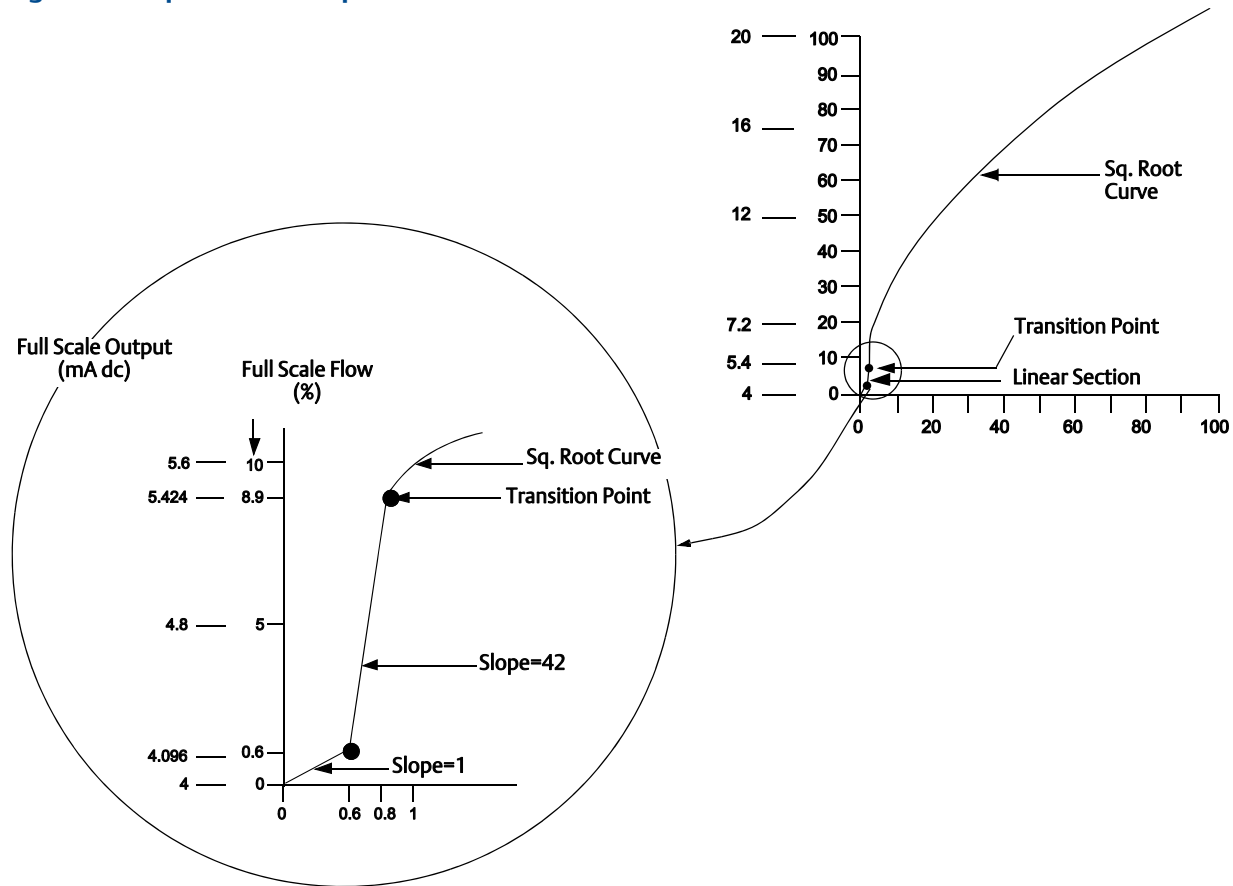

2.9.3 Rerange

The *Range Values* command sets the 4 and 20 mA points (lower and upper range values). Setting the range values to the limits of expected readings maximizes transmitter performance. In practice, you may reset the transmitter range values as often as necessary to reflect changing process conditions.

There are three methods available to rerange the transmitter. Each method is unique; examine all three closely before deciding which method to use.

2.9.4 Rerange with a communicator only

HART Fast Keys	1, 2, 3, 1, 1
-----------------------	---------------

Reranging using only the communicator changes the values of the analog 4 and 20 mA points independently without a pressure input.

Note

Changing the lower or upper range point results in similar changes to the span.

To rerange using only the communicator, enter the Fast Key sequence above, select **1 Keypad input**, and follow the online instructions. Or enter the values directly from the *ONLINE* screen.

Note

If the transmitter security jumper is in the *ON* position, you will not be able to make adjustments to the zero and span. Refer to [Figure 2-1 on page 5](#) for the appropriate placement of the transmitter security jumper.

2.9.5 Rerange with a pressure input source and a communicator

HART Fast Keys	1, 2, 3, 1, 2
-----------------------	---------------

Reranging using the communicator and a pressure source or process pressure is a way of reranging the transmitter with a pressure input. When specific 4 and 20 mA points are not known process input can be used. This method changes the values of the analog 4 and 20 mA points.

Note

When setting the 4 mA point, the span is maintained; when setting the 20 mA point, the span changes. If setting the lower range point to a value that causes the upper range point to exceed the sensor limit, the upper range point is automatically set to the sensor limit, and the span is adjusted accordingly.

To rerange using the communicator and a pressure source or process pressure, enter the Fast Key sequence above, select **2 Apply values**, and follow the online instructions.

Note

If the transmitter security jumper is in the *ON* position, no adjustments can be made to the zero and span. Refer to [Figure 2-1 on page 5](#) for the appropriate placement of the transmitter security jumper.

2.9.6 Rerange with a pressure input source and the local zero and span buttons

Reranging using the local zero and span adjustments (see [Figure 2-6 on page 12](#)) and a pressure source or process pressure is a way of reranging the transmitter with a pressure input and when a communicator is not available. When specific 4 and 20 mA points are not known process input can be used.

Note

When setting the 4 mA point, the span is maintained; when setting the 20 mA point, the span changes. If setting the lower range point to a value that causes the upper range point to exceed the sensor limit, the upper range point is automatically set to the sensor limit and the span is adjusted accordingly.

To rerange the transmitter using the span and zero buttons, perform the following procedure.

1. Loosen the screw holding the label on top of the transmitter housing, and rotate the label to expose the zero and span buttons (see [Figure 2-6 on page 12](#)).
2. Using a pressure source with an accuracy three to ten times the desired calibrated accuracy, apply a pressure equivalent to the lower range value to the high side of the transmitter.
3. To set the 4 mA point, press and hold the zero button for at least two seconds, then verify the output is 4 mA. If a meter is installed, it will display ZERO PASS.
4. Apply a pressure equivalent to the upper range value to the high side of the transmitter.
5. To set the 20 mA point, press and hold the span button for at least two seconds, then verify the output is 20 mA. If a meter is installed, it will display SPAN PASS.

Note

If the transmitter security jumper is in the *ON* position, or if the local zero and span adjustments are disabled through the software, adjustments to the zero and span cannot be made using the local buttons. Refer to [Figure 2-1 on page 5](#) for the proper placement of the transmitter security jumper. Or refer to “[Local span and zero control \(local keys\)](#)” on [page 13](#) in Section 2 for instructions on how to enable the span and zero buttons.

Figure 2-6. Local Zero and Span Adjustments

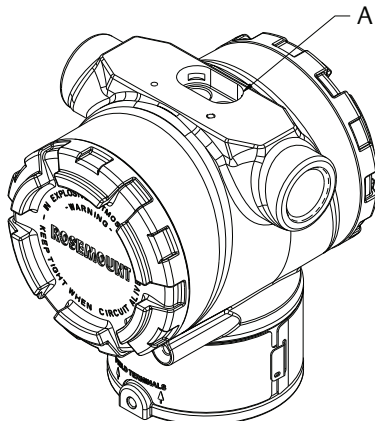

A. Span and Zero Adjustment buttons

After reranging the transmitter using the span and zero adjustments, it is possible to disable the adjustments to prevent further reranging. Refer to “[Local span and zero control \(local keys\)](#)” below for more information.

2.9.7 Damping

HART Fast Keys	1, 3, 6
-----------------------	---------

The process variable (PV) *Damp* command changes the response time of the transmitter to smooth variations in output readings caused by rapid changes in input. Determine the appropriate damping setting based on the necessary response time, signal stability, and other requirements of the of loop dynamics of your system. The default damping value is 0.4 seconds,⁽¹⁾ and can be reset to any of eleven pre-configured, nominal damping values between 0 and 25.6 seconds.

1. Rosemount 3051ND0 default damping is 3.2 seconds. Rosemount 3051ND1, with calibrations below 2.5 inH₂O (0,62 kPa), have damping set at 3.2 seconds.

2.9.8 LCD display meter options

HART Fast Keys	1, 4, 3, 4
-----------------------	------------

The *Meter Options* command allows you to customize the LCD display meter for use in your application. The meter can be configured to display the following information:

- Engineering units
- Percent of range
- User-configurable LCD display scale
- Alternating between any two of the above

The user-configurable scale is a feature that enables you to configure the LCD display meter to a custom scale using a HART Communicator. This feature can be used to define the decimal point position, the upper range value, the lower range value, the engineering units, and transfer function. Refer to “[Custom meter configuration](#)” on page 52 for complete configuration information.

2.10 Detailed setup

2.10.1 Local span and zero control (local keys)

HART Fast Keys	1, 4, 4, 1, 7
-----------------------	---------------

The *Local keys* command allows software control over the use of the local span and zero adjustments. To enable or disable the span and zero adjustment buttons on the transmitter, perform the Fast Key sequence above.

Note

Disabling the local keys does not disable all transmitter configuration changes. With the local keys disabled, changes to the transmitter configuration can still be made—including range values—using a HART Communicator.

2.10.2 Sensor temperature output unit selection

HART Fast Keys	1, 4, 1, 2, 2
-----------------------	---------------

The *Sensor Temperature Output Unit Selection* command selects between Celsius and Fahrenheit units for output of the sensor temperature. The sensor temperature output is accessible via HART only.

2.11 Diagnostics and service

The diagnostics and service functions listed here are primarily for use after installing the transmitter in the field. The transmitter test feature is designed to verify the transmitter is operating properly, and can be performed either on the bench or in the field. The loop test feature is designed to verify proper loop wiring and transmitter output, and should only be performed after installing the transmitter.

2.11.1 Transmitter test

HART Fast Keys	1, 2, 1, 1
-----------------------	------------

The transmitter *Self Test* command initiates a more extensive diagnostics routine than that performed continuously by the transmitter. The transmitter test routine can quickly identify potential electronics problems. If the transmitter test detects a problem, messages to indicate the source of the problem are displayed on the communicator screen.

2.11.2 Loop test

HART Fast Keys	1, 2, 2
-----------------------	---------

The *Loop Test* command verifies the output of the transmitter, the integrity of the loop, and the operations of any recorders or similar devices installed in the loop. To initiate a loop test, perform the following procedure.

1. Connect a reference meter to the transmitter. To do so, either connect the meter to the test terminals on the transmitter terminal block, or shunt the power to the transmitter through the meter at some point in the loop.
2. From the *ONLINE* screen, select **1 Device Setup > 2 Diagnostics and Service > 2 Loop Test**, to prepare to perform a loop test.
3. Set the control loop to manual (see “[Setting the loop to manual](#)” on page 6). The communicator displays the loop test menu.
4. Select **OK**.
5. Select a discreet milliamp level for the transmitter to output. At the *CHOOSE ANALOG OUTPUT* prompt, select **1 4mA > 2 20mA**, or select **3 other** to manually input a value.

Note

If performing a loop test to verify the transmitter output, enter a value between 4 and 20 mA. If performing a loop test to verify the transmitter alarm levels, enter the milliamp value representing an alarm state ([Table 2-1 on page 4](#)).

6. Check the electrical current meter installed in the test loop to verify it reads the value commanded the transmitter to output.

Note

If the readings match, then the transmitter and loop are configured and functioning properly. If the readings do not match, then the current meter may be attached to the wrong loop, there may be a fault in the wiring or elsewhere in the loop, the transmitter may require an output trim, or the electrical current meter may be malfunctioning.

After completing the test procedure, the display returns to the loop test screen and allows selection of another output value or exit loop testing.

Note

If the HART Communicator is disconnected from the process loop or loses power prior to exiting loop testing, output will remain fixed at the loop test value.

2.12 Calibration

Calibrating a smart transmitter is different from calibrating an analog transmitter. The one-step calibration process of an analog transmitter is done in three steps with a smart transmitter.

- **Rerange**—sets the 4 and 20 mA points at the desired pressures;
- **Sensor Trim**—Adjusts the position of the factory characterization curve to optimize the transmitter performance over a specified pressure range or to adjust for mounting effects;
- **Analog Output Trim**—Adjusts the analog output to match the plant standard or the control loop.

Smart transmitters operate differently than analog transmitters. A smart transmitter uses a microprocessor and sensor memory that contains information about the sensor’s specific characteristics in response to pressure and temperature inputs. A smart transmitter compensates for these sensor variations. The process of generating the sensor performance profile is called factory characterization. Factory characterization also provides the ability to readjust the 4 and 20 mA points without applying pressure to the transmitter.

The trim and rerange functions also differ. Reranging sets the transmitter analog output to the selected upper and lower range points and can be done with or without an applied pressure. Reranging does not change the factory characterization curve stored in the microprocessor. Sensor trimming requires an accurate pressure input and adds additional compensation that adjusts the position of the factory characterization curve to optimize transmitter performance over a specific pressure range.

Note

Sensor trimming adjusts the position of the factory characterization curve. It is possible to degrade the performance of the transmitter if the sensor trim is done improperly or with inaccurate equipment. Contact Rosemount Nuclear Instruments, Inc. at 952-949-5200 if there are questions.

Table 2-2. Standard Alarm and Saturation Values

Transmitter	Bench calibration tasks	Field calibration tasks
Rosemount 3051ND Rosemount 3051NG	<ol style="list-style-type: none"> 1. Set output configuration parameters. <ol style="list-style-type: none"> a. Set the process variable units. b. Set the output type. c. Set the range points. d. Set the damping value. 2. <i>Optional:</i> Perform a full sensor trim (accurate multimeter required). 3. <i>Optional:</i> Perform an analog output trim (accurate multimeter required). 	<ol style="list-style-type: none"> 1. Reconfigure parameters if necessary. 2. Zero trim the transmitter to compensate for mounting effects or static pressure effects.
Rosemount 3051NA	<ol style="list-style-type: none"> 1. Set output configuration parameters: <ol style="list-style-type: none"> a. Set the process variable units. b. Set the output type. c. Set the range points. d. Set the damping value. 2. <i>Optional:</i> Perform a full sensor trim if equipment available (accurate absolute pressure source required), otherwise perform the low trim value section of the full sensor trim procedure. 3. <i>Optional:</i> Perform an analog output trim (accurate multimeter required). 	<ol style="list-style-type: none"> 1. Reconfigure parameters if necessary. 2. Perform low trim value section of the full sensor trim procedure to correct for mounting position effects.

Note

A HART Communicator is required for all sensor and output trim procedures. Rosemount 3051N Transmitter Range 4 and Range 5 Transmitters require a special calibration procedure when used in differential pressure applications under high static line pressure (see “Compensating Rosemount 3051N Range 4 and 5 Differential Transmitters for line pressure” on page 22).

2.12.1 Calibration overview

Complete calibration of the Rosemount 3051N Pressure Transmitter involves the following tasks.

Configure the analog output parameters

- Set Process Variable Units (page 9)
- Set Output Type – Linear or Square Root (page 10)
- Set the Range Points (page 10)
- Set Damping (page 12)

Calibrate the sensor

- Full Trim (page 19)
- Zero Trim (page 18)

Calibrate the 4–20 mA output (digital-to-analog [D/A] signal conversion)

- 4–20 mA Output Trim (page 21) or
- 4–20 mA Output Trim using other scale (page 21)

Figure 2-7 on page 17 illustrates the Rosemount 3051N Transmitter data flow. This data flow can be summarized in four major steps.

1. A change in pressure is measured by a change in the sensor output (Sensor Signal).
2. The sensor signal is converted to a digital format that can be understood by the microprocessor (Analog-to-Digital Signal Conversion).
3. Corrections are performed in the microprocessor to obtain a digital representation of the process input (Digital PV).
4. The Digital PV is converted to an analog value (Digital-to-Analog Signal Conversion).

Figure 2-7 also identifies the approximate transmitter location for each calibration task. Note the data flows from left to right, and a parameter change affects all values to the right of the changed parameter.

Not all calibration procedures should be performed for each Rosemount 3051N Transmitter. In addition, some procedures are appropriate for bench calibration but should not be performed during field calibration. Table 2-2 identifies the recommended calibration procedures for each type of Rosemount 3051N Transmitter for both bench and field calibration.

Figure 2-7. Transmitter Data Flow with Calibration Options

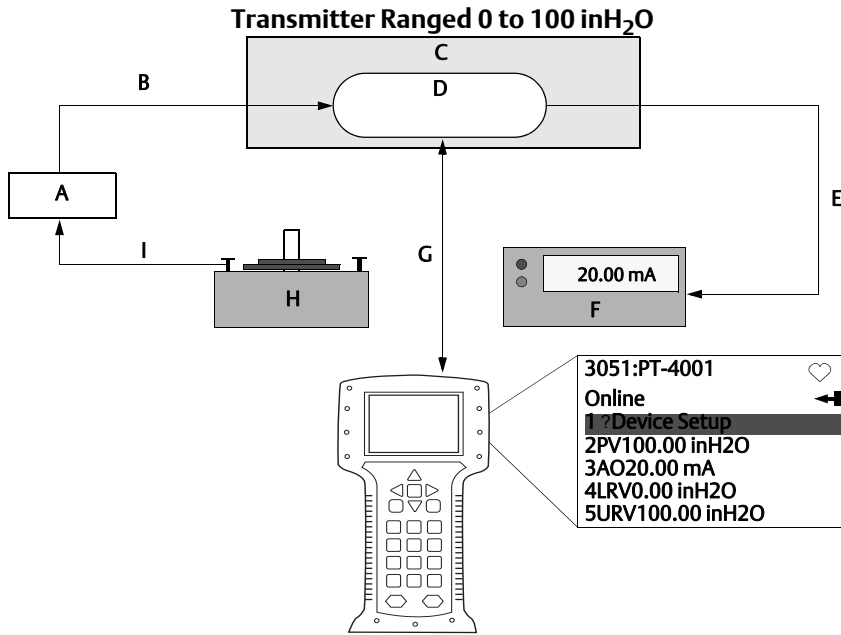

- A. Sensor
- B. Sensor signal
- C. Transmitter electronics module
- D. Microprocessor digital PV
- E. Analog output
- F. Output device
- G. HART Communicator
- H. Input device
- I. Input pressure

Note

Value on PV line should equal the input pressure. Value on AO line should equal the output device reading.

2.12.2 Deciding which trim procedure to use

To decide which trim procedure to use, first determine whether the analog-to-digital section or the digital-to-analog section of the transmitter electronics is in need of calibration. To do so, refer to Figure 2-7 and perform the following procedure.

1. Connect a pressure source, a HART Communicator, and a digital readout device to the transmitter.
2. Establish communication between the transmitter and the communicator.
3. Apply pressure equal to the upper range point pressure (100 inH₂O, for example).
4. Compare the applied pressure to the Process Variable (PV) line on the Communicator Online Menu. If the PV reading on the communicator does not match the applied pressure, and the test equipment is accurate, perform a sensor trim.
5. Compare the Analog Output (AO) line on the communicator online menu to the digital readout device. If the AO reading on the communicator does not match the digital readout device, and the test equipment is accurate, perform an output trim.

2.12.3 Sensor trim

The sensor can be trimmed using either the full trim or the zero trim function. The trim functions vary in complexity, and their use is application-dependent. Both trim functions alter the transmitter’s interpretation of the input signal.

A **zero trim** is a single-point adjustment. It is useful when compensating for mounting position effects and is most effective when performed with the transmitter installed in its final mounting position. Since this correction maintains the slope of the characterization curve, it should not be used in place of a full trim over the full sensor range.

When performing a zero trim, ensure the equalizing valve is open and all wet legs are filled to the correct levels.

Note

Do not perform a zero trim on Rosemount 3051N Absolute Pressure Transmitters. A zero trim is zero-based, and absolute pressure transmitters reference absolute zero. To correct mounting position effects on a Rosemount 3051N Absolute Pressure Transmitter, perform a low trim within the full sensor trim function. The low trim function provides a “zero” correction similar to the zero trim function but it does not require the input to be zero-based.

Figure 2-8. Typical Zero vs. Non-Zero-Based Application

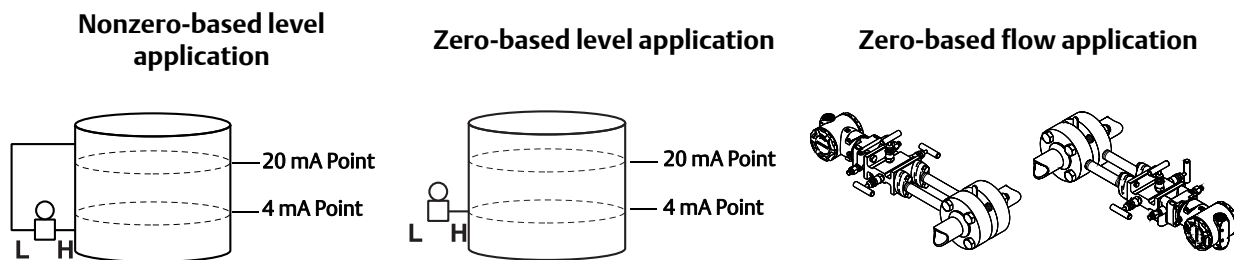

A **full trim** is a two-point sensor calibration where two end-point pressures are applied, and all output is linearized between them. Always adjust the low trim value first to establish the correct offset. Adjustment of the high trim value provides a slope correction to the characterization curve based on the low trim value. The factory-established characterization curve is not changed by this procedure. The trim values allows performance to be optimized over a specified measuring range at the calibration temperature.

2.12.4 Zero trim

HART Fast Keys	1, 2, 3, 3, 1
-----------------------	---------------

To calibrate the sensor with a HART Communicator using the *Zero Trim* function, perform the following procedure.

1. Vent the transmitter and attach a communicator to the measurement loop.
2. From the communicator menu select **1 Device setup > 2 Diagnostics and service > 3 Calibration > 3 Sensor trim > 1 Zero trim** to prepare to adjust the zero trim.

Note

The transmitter must be within three percent of true zero (zero-based) in order to calibrate it using the zero trim function.

3. Follow the commands provided by the communicator to complete the adjustment of the zero trim.

2.12.5 Full trim

HART Fast Keys	1, 2, 3, 3
-----------------------	------------

To calibrate the sensor with a HART Communicator using the full trim function, perform the following procedure.

1. Assemble and power the entire calibration system including a transmitter, HART Communicator, power supply, pressure input source, and readout device (see [Figure 2-9](#)).

Note

Use a pressure input source with sufficient accuracy and allow the input pressure to stabilize for 10 seconds before entering any values.

2. From the communicator menu select **1 Device setup > 2 Diagnostics and service > 3 Calibration > 3 Sensor trim > 2 Lower sensor trim** to prepare to adjust the lower trim point.

Note

Select pressure input values so the low and high values are equal to or outside the 4 and 20 mA points. Do not attempt to obtain reverse output by reversing the high and low points. The transmitter allows approximately a five percent URL deviation from the characterized curve established at the factory.

3. Follow the commands provided by the communicator to complete the adjustment of the lower value.
4. Repeat the procedure for the upper value, replacing *2 Lower sensor trim* with **3 Upper sensor trim** in [Step 2](#).

Figure 2-9. Digital Trim Connection Drawing (4–20 mA Transmitters)

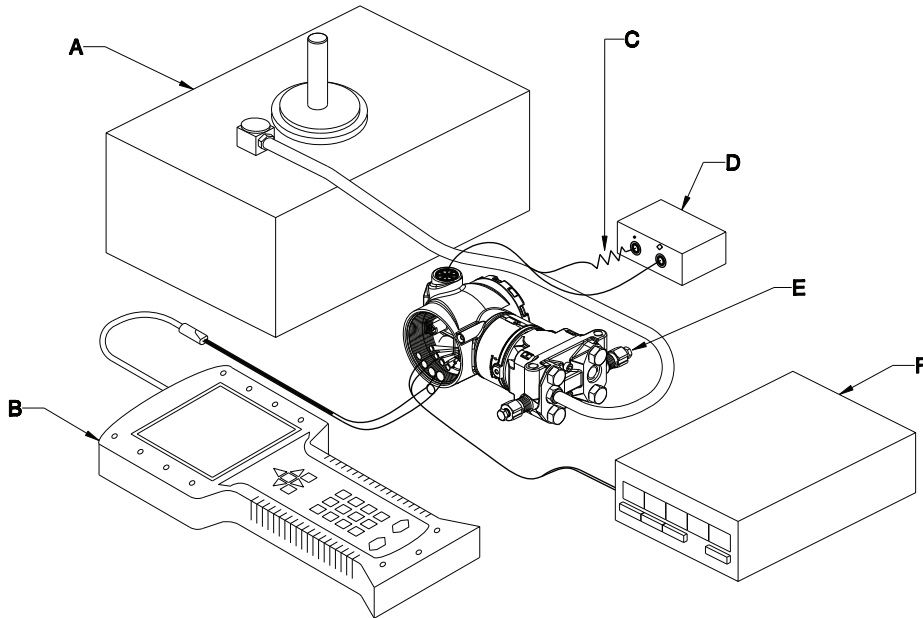

- A. Dead weight tester (calibration standard for sensor trim only)
- B. HART-based communicator
- C. 250 ohm minimum loop resistance
- D. 24 Vdc power supply
- E. Rosemount 3051N Pressure Transmitter
- F. Precision meter

2.12.6 Recall factory trim

The *Recall Factory Trim* commands allow the restoration of the as-shipped factory settings of the sensor trim and analog output trim.

2.12.7 Recall factory trim— sensor trim

HART Fast Keys	1, 2, 3, 4, 1
-----------------------	---------------

Resets the transmitter sensor trim to the as-shipped factory settings. The *Recall Factory Trim—Sensor Trim* command can be useful for recovering from an inadvertent zero trim of an absolute pressure unit.

2.12.8 Recall factory trim— analog output

HART Fast Keys	1, 2, 3, 4, 2
-----------------------	---------------

Resets the transmitter analog output trim to the as-shipped factory settings. The *Recall Factory Trim—Analog Output Trim* command can be useful for recovering from an inadvertent zero trim on an absolute pressure transmitter.

2.12.9 Analog output trim

The *Analog Output Trim* commands allow you to adjust the transmitter’s current output at the 4 and 20 mA points to match the plant standards. This command adjusts the digital to analog signal conversion (see [Figure 2-7 on page 17](#)).

2.12.10 Digital-to-analog trim

HART Fast Keys	1, 2, 3, 2, 1
-----------------------	---------------

To perform a digital-to-analog trim with a HART Communicator, perform the following procedure.

1. From the *ONLINE* screen, select **1 Device Setup > 2 Diag/Service > 3 Calibration > 2 Trim Analog Output > 1 Digital-to-Analog Trim**.
2. Select **OK** after setting the control loop to manual (see “[Setting the loop to manual](#)” on page 6).
3. At the *CONNECT REFERENCE METER* prompt, connect an accurate reference ammeter to the transmitter.
 - a. Connect the positive lead to the positive terminal and the negative lead to the test terminal in the transmitter terminal compartment.OR
 - b. Shunt the transmitter power through the reference meter at some point.
4. Select **OK** after connecting the reference meter.
5. At the *SETTING FLD DEV OUTPUT TO 4 MA* prompt, select **OK**. The transmitter outputs 4.00 mA.
6. Record the actual value from the reference meter, and enter it at the *ENTER METER VALUE* prompt. The communicator prompts to verify whether or not the output value equals the value on the reference meter.
7. Select **1 Yes** if the reference meter value equals the transmitter output value, or **2 No** if it does not. If you select **1 Yes**, then proceed to [Step 8](#). If you select **2 No**, then repeat [Step 6](#).
8. At the *SETTING FLD DEV OUTPUT TO 20 MA* prompt, select **OK** and repeat [Step 6](#) and [Step 7](#) until the reference meter value equals the transmitter output value.
9. Select **OK** after returning the control loop to automatic control.

2.12.11 Digital-to-analog trim using other scale

HART Fast Keys	1, 2, 3, 2, 2
-----------------------	---------------

The *Scaled D/A Trim* command matches the 4 and 20 mA points to a user-selectable reference scale other than 4 and 20 mA (1 to 5 volts if measuring across a 250 ohm load, or 0 to 100 percent if measuring from a DCS, for example). To perform a scaled D/A trim, connect an accurate reference meter to the transmitter and trim the output signal to scale as outlined in the [Analog output trim](#) procedure.

Note

Use a precision resistor for optimum accuracy. If adding a resistor to the loop, ensure the power supply is sufficient to power the transmitter to a 20 mA output with the additional loop resistance.

2.12.12 Compensating Rosemount 3051N Range 4 and 5 Differential Transmitters for line pressure

Rosemount 3051N Range 4 and Range 5 Pressure Transmitters require a special calibration procedure when used in differential pressure applications. The purpose of this procedure is to optimize transmitter performance by reducing the effect of static line pressure (P_s) in these applications. Rosemount 3051N Differential Pressure Transmitter ranges 0, 1, 2, and 3 do not require this procedure because the optimization occurs in the sensor. See “[Static pressure effect](#)” on page 43 for additional details.

Applying high static pressure to Rosemount 3051N Range 4 and Range 5 Pressure Transmitters causes a systematic shift in the output. This shift is linear with static pressure; correct it by performing the “[Full trim](#)” on page 19, after determining the corrected input values as noted below.

The following specifications show the static pressure effect for Rosemount 3051N Range 4 and Range 5 Transmitters used in differential pressure applications:

Zero effect

$\pm 0.1\%$ of the upper range limit per 1000 psi (6,9 MPa) for line pressures (P_s) from 0 to 2000 psi (0 to 13,8 MPa)

$\pm [0.2 + 0.2 (P_s - 2000) / 1000]\%$ of the upper range limit per 1000 psi (6,9 MPa) for line pressures above 2000 psi (13,8 MPa) and ≤ 3626 psi (25 MPa)

Span effect

Correctable to $\pm 0.2\%$ of reading per 1000 psi for line pressures from 0 to 3626 psi.

The systematic span shift caused by the application of static line pressure is -1.00% of input reading per 1000 psi for Rosemount 3051N Range 4 transmitters, and -1.25% of reading per 1000 psi for Range 5 transmitters.

Use the following example to compute corrected input values.

Example

A Rosemount 3051ND4 Transmitter will be used in a differential pressure application where the static line pressure is 1200 psi. The transmitter is ranged so the output is 4 mA at 500 inH₂O and 20 mA at 1500 inH₂O.

To correct for systematic error caused by high static line pressure, first use the following formulas to determine corrected values for the low trim and high trim.

$$LT_c = LRV + S (LRV) P_s$$

Where:

- LT_c = Corrected Low Trim Value
- LRV = Lower Range Value
- S = $-(\text{Systematic Span shift per specification})$
- P_s = Static Line Pressure

$$HT_c = URV + S (URV) P_s$$

Where:

- HT_c = Corrected High Trim Value
- URV = Upper Range Value
- S = $-(\text{Span shift per specification})$
- P_s = Static Line Pressure

In this example:

$$URV = 1500 \text{ inH}_2\text{O}$$

$$LRV = 500 \text{ inH}_2\text{O}$$

$$P_s = 1200 \text{ psi}$$

$$S = -(-0.01/1000 \text{ psi}) = 0.01/1000 \text{ psi}$$

To calculate the corrected low trim (LT_c) value:

$$LT_c = 500 \text{ in H}_2\text{O} + (0.01/1000 \text{ psi})(500 \text{ in H}_2\text{O})(1200 \text{ psi})$$

$$LT_c = 506 \text{ in H}_2\text{O}$$

To calculate the corrected high trim (HT_c) value:

$$HT_c = 1500 \text{ in H}_2\text{O} + (0.01/1000 \text{ psi})(1500 \text{ in H}_2\text{O})(1200 \text{ psi})$$

$$HT_c = 1518 \text{ in H}_2\text{O}$$

To complete a Rosemount 3051N Transmitter full trim, enter the corrected values for low trim (LT) and high trim (HT). Refer to [“Full trim” on page 19](#).

Enter the corrected input values for low trim and high trim through the communicator keypad after applying the nominal value of pressure as the transmitter input.

Note

After calibrating Rosemount 3051N Range 4 and Range 5 Transmitters for high differential pressure applications, rerange the 4 and 20 mA points using the communicator to maintain the systematic static line pressure correction. The 4 mA point at line pressure may be re-zeroed after installation using the local zero button without affecting the completed calibration.

This page intentionally left blank

Section 3 Installation

Overview	page 25
Safety messages	page 25
General considerations	page 27
Mechanical considerations	page 27
Electrical considerations	page 34
Environmental considerations	page 36

3.1 Overview

The information in this section covers installation considerations. Dimensional drawings illustrating the Rosemount™ 3051N Transmitter and mounting brackets are included in this section.

3.2 Safety messages

Procedures and instructions in this section may require special precautions to ensure the safety of the personnel performing the operation. Information that raises potential safety issues is indicated by a warning symbol (⚠). Refer to the following safety messages before performing an operation preceded by this symbol.

⚠ WARNING

Explosions can result in death or serious injury.

- Do not remove the transmitter covers in explosive environments when the circuit is alive.
- Verify the operating atmosphere of the transmitter is consistent with the appropriate qualification parameters.

Electrical shock can result in death or serious injury.

- Avoid contact with the leads and terminals.

Process leaks could result in death or serious injury.

- Install and tighten all four flange bolts before applying pressure.
- Do not attempt to loosen or remove flange bolts while the transmitter is in service.

Replacement equipment or spare parts not approved by Rosemount Nuclear Instruments, Inc. for use as spare parts could reduce the pressure retaining capabilities of the transmitter and may render the instrument dangerous or adversely impact its qualification status.

- Use only components supplied with the Rosemount 3051N or sold by Rosemount Nuclear Instruments Inc. as spare parts for the Rosemount 3051N.

Improper assembly of manifold or mounting bracket to traditional flange can damage sensor module.

- For safe assembly of manifold or mounting bracket to traditional flange, bolts must break back plane of flange web (i.e. bolt hole), but must not contact module housing.
-

Figure 3-1. Typical Installation Flowchart

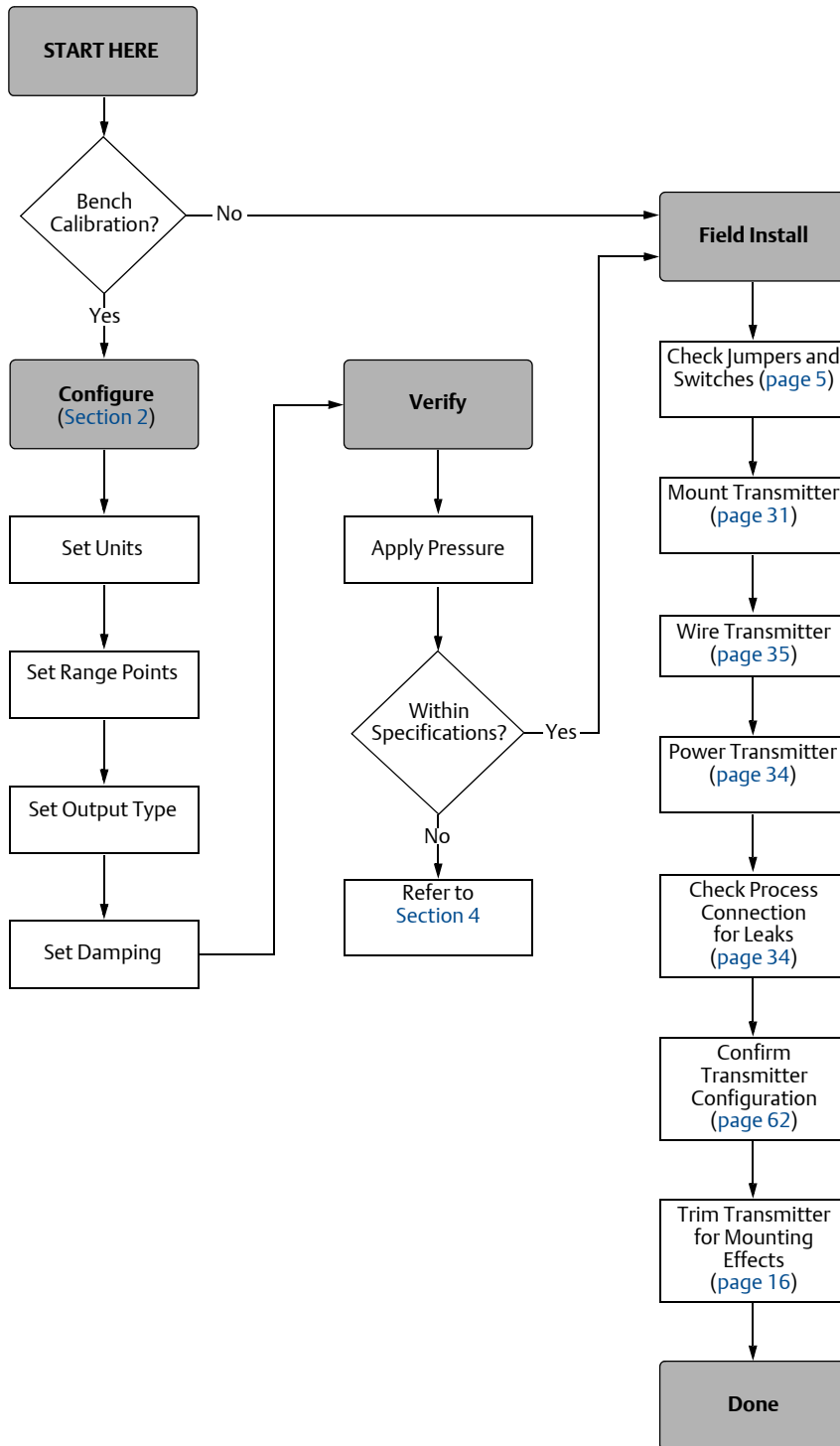

3.3 General considerations

Measurement accuracy depends upon proper installation of the transmitter and impulse piping. Mount the transmitter close to the process and use a minimum of piping to achieve best accuracy. Keep in mind the need for easy access, personnel safety, practical field calibration, and a suitable transmitter environment. Install the transmitter to minimize vibration, shock, and temperature fluctuation.

3.3.1 Special draft range considerations

Installation

It is best to mount the transmitter with the isolating diaphragms parallel to the ground. Installing the transmitter in this way reduces oil head effect and provides for optimal temperature performance.

Be sure the transmitter is securely mounted. Tilting of the transmitter may cause a zero shift in the transmitter output.

Reducing process noise

It is often difficult to isolate the actual process variable from process noise in draft range applications. Pressure fluctuations and air currents can make accurate draft range measurements difficult to obtain.

There are two recommended methods of reducing process noise: output damping and, in gage applications, reference side filtering.

Output damping

The output damping for the Rosemount 3051ND0 is factory set to 3.2 seconds as a default. If the transmitter output is still noisy, increase the damping time. If faster response is needed, decrease the damping time. Damping adjustment information is available in [Section 2: Transmitter Functions](#).

Reference side filtering

In gage applications, it is important to minimize fluctuations in atmospheric pressure to which the low side isolator is exposed. One method of reducing fluctuations in atmospheric pressure is to attach a length of tubing to the reference side of the transmitter to act as a pressure buffer. Another method is to plumb the reference side to a chamber that has a small vent to atmosphere. If multiple draft transmitters are being used in an application, the reference side of each device can be plumbed to a chamber to achieve a common gage reference.

Important

Install the enclosed pipe plug in unused conduit openings with a minimum of five threads engaged to comply with explosion proof requirements.

3.4 Mechanical considerations

The following figures show dimensional drawings and installation examples of the Rosemount 3051N Transmitters including mounting brackets.

3.4.1 Rosemount 3051ND0 and 3051ND1

For Rosemount 3051ND0 and 3051ND1, mount the transmitter solidly to prevent tilting. A tilt in the physical transmitter may cause a zero shift in the transmitter output.

3.4.2 Steam service

For steam service, do not blow down impulse piping through the transmitter. Flush the lines with the blocking valves closed and refill the lines with water before resuming measurement.

3.4.3 Side mounting

When the transmitter is mounted on its side, position the coplanar process flange to ensure proper venting or draining. Keep drain/vent connections on the bottom for gas service and on the top for liquid service.

3.4.4 Independent seals

The Rosemount 3051N Transmitter incorporates two independent seals between the process connection and the conduit connection.

Figure 3-2. Coplanar Flange Mounting Configurations with Optional Bracket (Code B4) for Panel Mounting

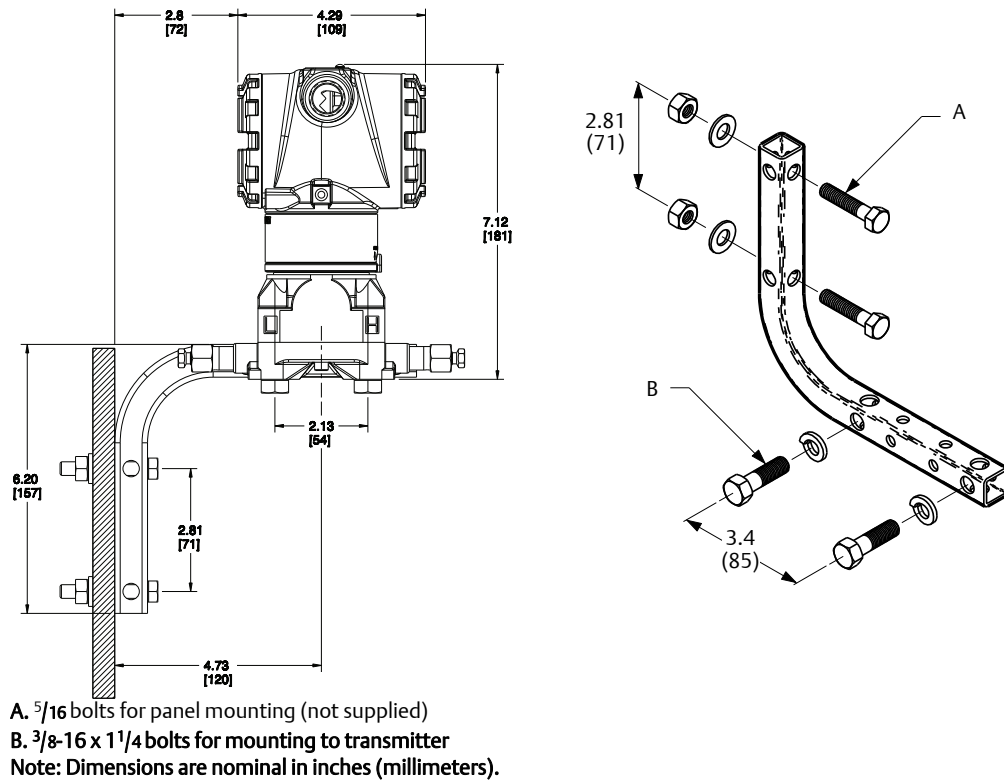
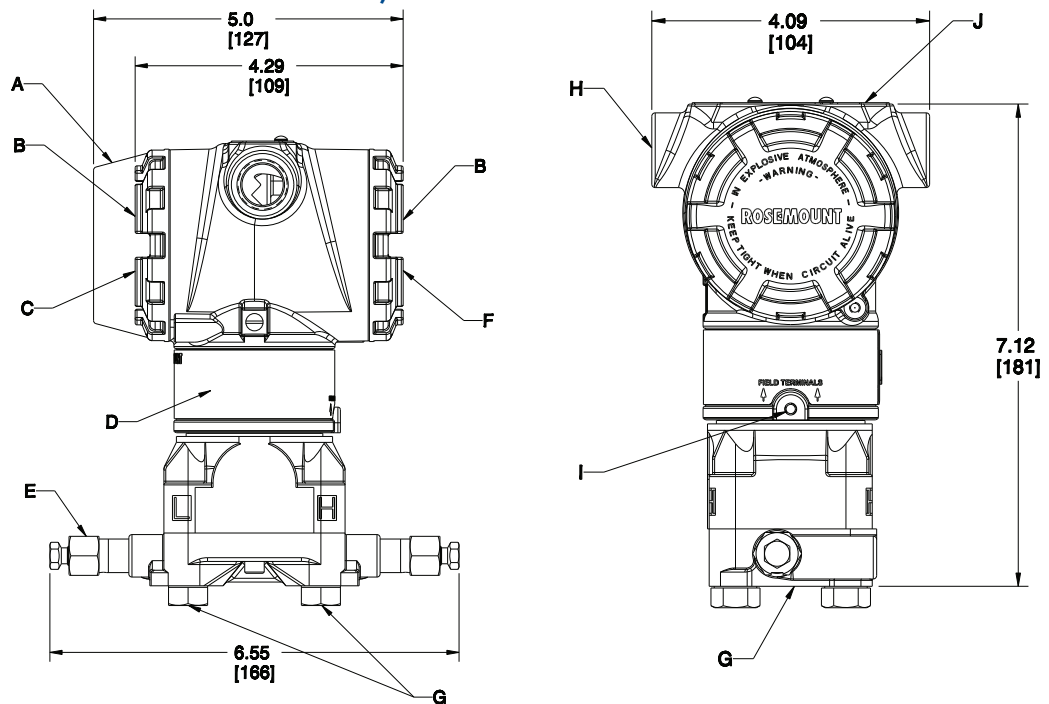

Figure 3-3. Rosemount 3051N Coplanar Flange Dimensional Drawing (Differential Pressure Transmitter Shown)



- A. Meter cover (optional)
 - B. 0.75 (20) clearance for cover removal
 - C. Transmitter circuitry
 - D. Nameplate
 - E. Drain/vent valve
- Note: Dimensions are nominal in inches (millimeters).

- F. Terminal connections
- G. 1/4-18 NPT on coplanar flange for pressure connection
- H. 1/2-14 NPT conduit connection (two places)
- I. Housing rotation set screw
- J. Label

Figure 3-4. Traditional Flange Mounting Configurations with Optional Brackets for Panel Mounting

Option code B2: Traditional flange panel mounting bracket (painted carbon steel)

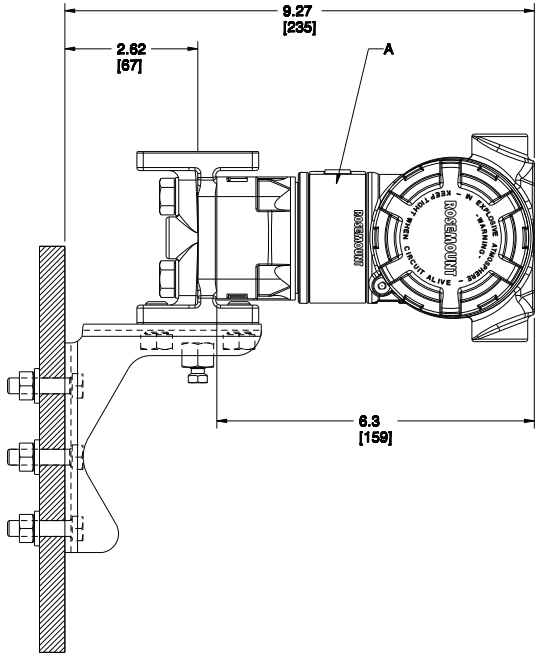

Option code BS: Traditional flange universal panel mounting bracket (stainless steel)

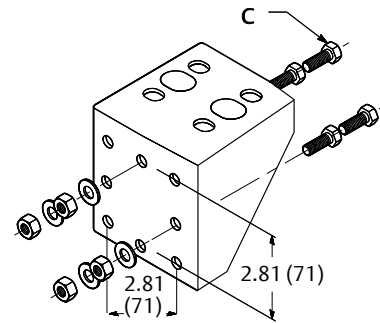
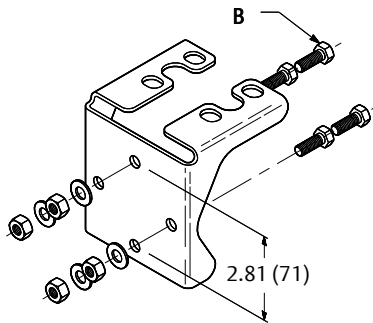
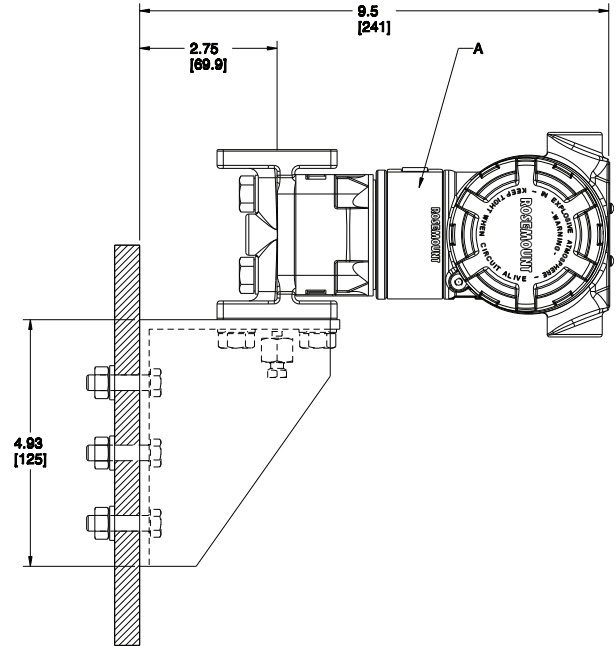

A. Nameplate
B. 5/16-in. bolts for panel mounting (not supplied)

C. 3/8-in. bolts for panel mounting (not supplied)
Note: Dimensions are nominal in inches (millimeters).

Figure 3-5. Traditional Flange (Option Code H2) Dimensional Drawing

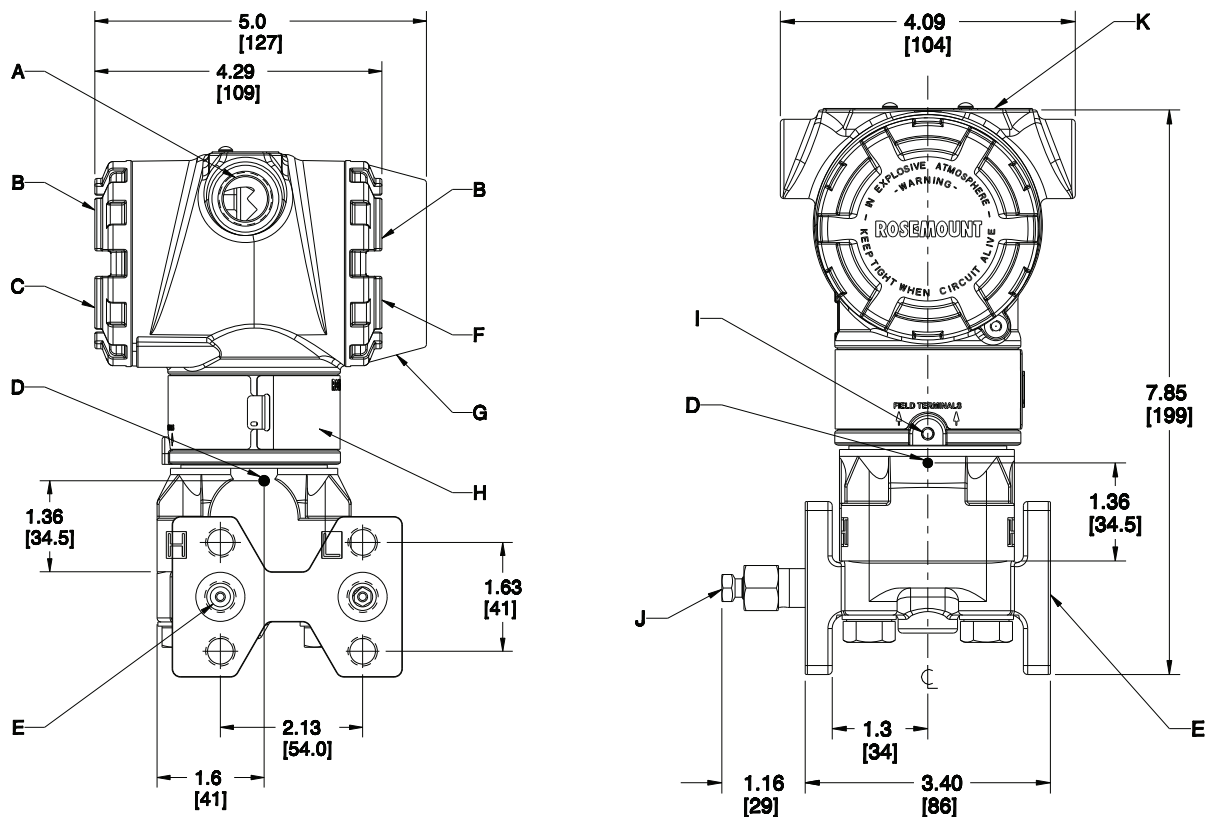

- A. 1/2-14 NPT conduit connection (two places)
- B. 0.75 (20) clearance for cover removal
- C. Terminal connections
- D. Center of gravity (aluminum housing without meter)
- E. 1/4-18 NPT on traditional flange for process connection
- F. Transmitter circuitry

- G. Meter cover (optional)
 - H. Nameplate
 - I. Housing rotation set screw
 - J. Drain/vent valve
 - K. Label
- Note: Dimensions are nominal in inches (millimeters).

3.4.5 Mounting

The Rosemount 3051N Pressure Transmitter weighs approximately 6.0 lb (2,7 kg) without additional options. For complete weight information, including options, see “Physical specifications” on page 45. Optional mounting brackets available with the Rosemount 3051N allow mounting to a panel or wall. The B4 bracket option for use with the coplanar flange is 316 SST and provided with 316 SST bolts.

Bracket option B2 is a polyurethane painted carbon steel bracket designed for use in panel mounting the traditional flange (H2). The B2 bracket is provided with carbon steel bolts.

Bracket option BS is a 316L SST bracket provided with carbon steel bolts that is designed for use in panel mounting the traditional flange (H2). It is the same bracket used on other Rosemount Nuclear Instruments, Inc. nuclear qualified transmitters, including the Rosemount 1153 Series D and Rosemount 1154.

Bracket option PM is a SST pipe mount bracket assembly designed for use in pipe mounting the traditional flange (H2). It is the same bracket used on other Rosemount Nuclear Instruments, Inc. nuclear qualified transmitters, including the Rosemount 1154 Series H.

When installing the transmitter to the mounting bracket, torque the mounting bolts to 21 ft.-lbs.

Dimensions and typical mounting configurations are contained in this section.

Note

The transmitter is calibrated in an upright position at the factory. If you mount the transmitter in any other position, the zero point will shift by an amount equivalent to the liquid head caused by the varied mounting position. To reset the zero point, refer to “[Sensor trim](#)” on page 18.

Mounting requirements

Refer to [Figure 3-6](#) for examples of the following mounting configurations.

Liquid flow measurement

- Place taps to the side of the line to prevent sediment deposits on the transmitter’s process isolators.
- Mount the transmitter beside or below the taps so gases can vent into the process line.
- Mount drain/vent valve upward to allow gases to vent.

Gas flow measurement

- Place taps in the top or side of the line.
- Mount the transmitter beside or above the taps so liquid will drain into the process line.

Steam flow measurement

- Place taps to the side of the line.
- Mount the transmitter below the taps to ensure that the impulse piping will stay filled with condensate.
- Fill impulse lines with water to prevent the steam from contacting the transmitter directly and to ensure accurate measurement start-up.

Note

In steam or other elevated temperature services, it is important that temperatures at the coplanar process flanges not exceed 250 °F (121 °C). In vacuum service, these temperature limits are reduced to 220 °F (104 °C).

Figure 3-6. Typical Installation Examples to Illustrate Transmitter and Impulse Piping Locations

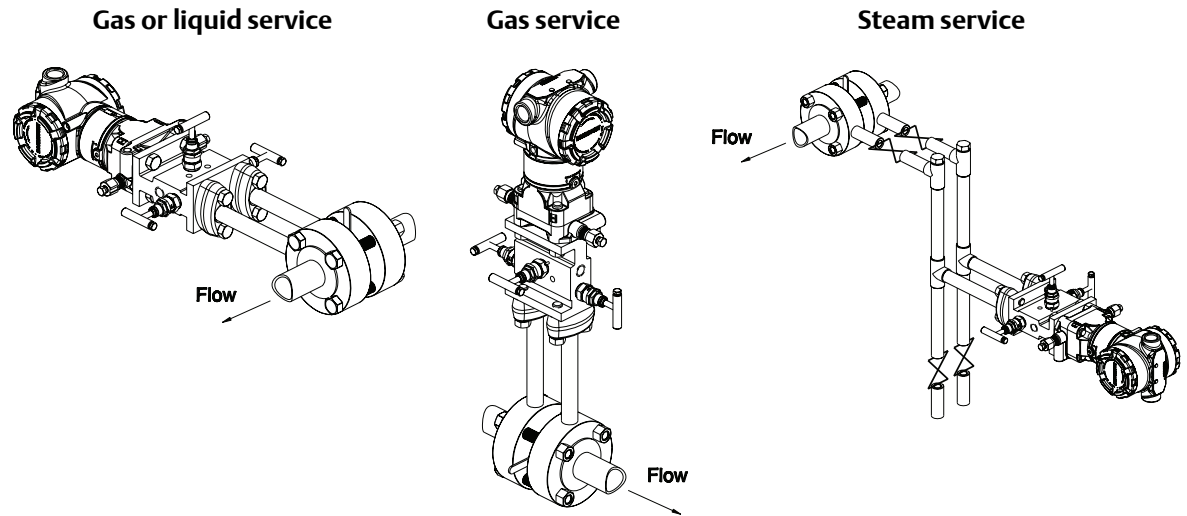

Impulse piping

The piping between the process and the transmitter must accurately transfer the pressure to obtain accurate measurements. There are several possible sources of error: pressure transfer, leaks, friction loss (particularly if purging is used), trapped gas in a liquid line, liquid in a gas line, and density variations between the legs. The best location for the transmitter in relation to the process pipe depends on the process itself. Use the following guidelines to determine transmitter location and placement of impulse piping:

- Keep impulse piping as short as possible.
- For liquid service, slope the impulse piping at least one inch per foot (eight cm per m) upward from the transmitter toward the process connection.
- For gas service, slope the impulse piping at least one inch per foot (eight cm per m) downward from the transmitter toward the process connection.
- Avoid high points in liquid lines and low points in gas lines.
- Make sure both impulse legs are the same temperature.
- Use impulse piping large enough to avoid friction effects and blockage.
- Vent all gas from liquid piping legs.
- When using a sealing fluid, fill both piping legs to the same level.
- When purging, make the purge connection close to the process taps and purge through equal lengths of the same size pipe. Avoid purging through the transmitter.
- Keep corrosive or hot (above 250 °F [121 °C]) process material out of direct contact with the sensor module and flanges.
- Prevent sediment deposits in the impulse piping.
- Keep the liquid head balanced on both legs of the impulse piping.
- Avoid conditions that might allow process fluid to freeze within the process flange.

3.4.6 Process connections

Rosemount 3051N connections on the transmitter flange are 1/4-18 NPT. Use your plant-approved lubricant or sealant when making the connections. The end-user is responsible for the qualification of the threaded seal interface on the transmitter's 1/4-18 NPT connections.

 Do not attempt to loosen or remove the flange bolts while the transmitter is in service.

3.4.7 Housing rotation

The electronics housing can be rotated up to 180 degrees (left or right) to improve field access or to better view the optional LCD display meter. To rotate the housing, perform the following procedure:

1. Loosen the housing rotation set screw using a 9/64-in. hex wrench.
2. Turn the housing up to 180 degrees to the left or right of its original (as shipped) position.

 **Note**
Do not rotate the housing more than 180 degrees. Over-rotation will sever the electrical connection between the sensor module and the electronics module.

3. Retighten the housing rotation set screw.

3.5 Electrical considerations

The transmitter terminal block is in the compartment of the electronics housing labeled “FIELD TERMINALS.” The other compartment contains the transmitter electronics module. Connections for the HART®-based communicator are attached beneath the terminal screws on the terminal block. [Figure 3-7](#) shows power supply load limitations for the transmitter.

 See “[Safety messages](#)” on [page 25](#) for warning information.

3.5.1 Power supply

4–20 mA transmitters

The dc power supply should provide power with less than two percent ripple. The total resistance load is the sum of the resistance of the signal leads and the load resistance of the controller, indicator, and related pieces. Note that the resistance of intrinsic safety barriers, if used, must be included.

Note
A minimum loop resistance of 250 ohms is required to communicate with a HART-based communicator. With 250 ohms of loop resistance, the transmitter will require a minimum of 16 volts to output 20 mA. If a single power supply is used to power more than one Rosemount 3051N Transmitter, the power supply used, and circuitry common to the transmitters, should not have more than 20 ohms of impedance at 1200 Hz. For additional details, see [Figure 3-7](#).

Figure 3-7. Power Supply Load Limitations

Max. Loop Resistance = 43.5 (Power Supply Voltage – 10.5) ohms

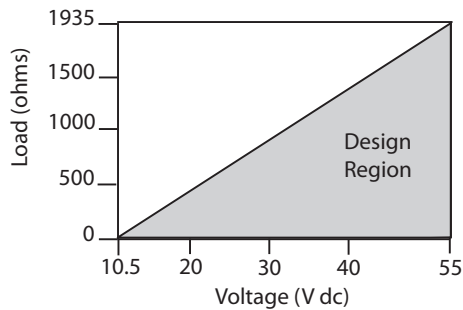

Communication requires a minimum loop resistance of 250 ohms.

3.5.2 Wiring

To make connections, perform the following procedure.

- ⚠ 1. Remove the housing cover on the side marked “FIELD TERMINALS.” Do not remove the cover in explosive atmospheres when the circuit is alive. All power to the transmitter is supplied over the signal wiring.
- ⚠ 2. Connect the lead that originates at the positive side of the power supply to the terminal marked “+” and the lead that originates from the negative side of the power supply to the terminal marked “-”. Avoid contact with the leads and terminals. Do not connect the powered signal wiring to the test terminals. Power could damage the test diode in the test connection.
- ⚠ See “**Safety messages**” on page 25 for warning information.
3. Plug and seal unused conduit connections on the transmitter housing to avoid moisture accumulation in the terminal side of the housing. If you do not seal the unused connections, mount the transmitter with the electrical housing positioned downward for drainage. Install wiring with a drip loop. Arrange the drip loop so the bottom is lower than the conduit connections and the transmitter housing.

Note

Signal wiring needs to be shielded, but use twisted pairs for best results. To ensure proper communication, use 24 AWG or larger wire, and do not exceed 5000 feet (1500 meters).

Do not use inductive-based transient protectors, including the Rosemount 470, as they can adversely affect the output of Rosemount 3051N 4–20 mA transmitters. The Rosemount 3051N includes the transient protection terminal block (T1) as standard.

Signal wiring grounding

Do not run signal wiring in conduit or open trays with power wiring, or near heavy electrical equipment. Ground the signal wiring at any one point on the signal loop, or leave it ungrounded. The negative terminal of the power supply is a recommended grounding point.

3.5.3 Grounding the transmitter case

The transmitter case should always be grounded in accordance with national and local electrical codes. The most effective transmitter case grounding method is direct connection to earth ground with minimal impedance. Methods for grounding the transmitter case include:

- **Internal Ground Connection:** The Internal ground connection screw is inside the *FIELD TERMINALS* side of the electronics housing. This screw is identified by a ground symbol () and is standard on all Rosemount 3051N Transmitters.
- **External Ground Assembly:** This assembly is included as standard with the transient protection terminal block (T1) included with the Rosemount 3051N.

Note

Grounding the transmitter case using the threaded conduit connection may not provide a sufficient ground. The standard transient protection terminal block (T1) does not provide transient protection unless the transmitter case is properly grounded. Use the above guidelines to ground the transmitter case. Do not run the transient protection ground wire with signal wiring as the ground wire may carry excessive current if a lightning strike occurs.

3.6 Environmental considerations

The following guidelines can help optimize transmitter performance. Mount the transmitter to minimize ambient temperature changes, vibration, mechanical shock, and to avoid external contact with corrosive materials. “[Temperature limits](#)” on [page 43](#) lists transmitter temperature operating limits.

3.6.1 Access requirements

When choosing an installation location and position, take into account the need for access to the transmitter.

Process flange orientation

Mount the process flanges with sufficient clearance for process connections. For safety reasons, place the drain/vent valves so the process fluid is directed away from technicians when the vents are used. In addition, consider the possible need for a testing or calibration input.

Housing rotation

See “[Housing rotation](#)” on [page 34](#).

Terminal side of electronics housing

Mount the transmitter so the terminal side is accessible. A 0.75-inch (19 mm) clearance is required for cover removal. Use a conduit plug on the unused side of the conduit opening.

Circuit side of electronics housing

Provide 0.75 inches (19 mm) clearance for cover removal. Three inches of clearance are required for cover removal if a meter is installed.

Exterior of electronics housing

The integral span and zero adjustments are located under the label plate on the top of the transmitter. Allow a minimum of 1.0 inch of clearance above the transmitter if intending to use the integral zero and span adjustments.

3.6.2 Cover installation

Always install the electronics housing covers metal-to-metal to ensure a proper seal.

This page intentionally left blank

Section 4 Troubleshooting

Overview	page 39
Safety messages	page 39
Returning Rosemount products and materials	page 40

4.1 Overview

Table 4-1 provides summarized troubleshooting suggestions for the most common operating problems. If a malfunction is suspected without any diagnostic messages on the communicator display, follow the procedures described here to verify that transmitter hardware and process connections are in good working order. Always deal with the most likely and easiest-to-check conditions first.

4.2 Safety messages

Procedures and instructions in this section may require special precautions to ensure the safety of the personnel performing the operations. Information that raises potential safety issues is indicated by a warning symbol (⚠). Refer to the following safety messages before performing an operation preceded by this symbol.

⚠ WARNING

Explosions can result in death or serious injury.

- Do not remove the transmitter covers in explosive environments when the circuit is alive.

⚠ CAUTION

Static electricity can damage sensitive components.

- Observe safe handling precautions for static-sensitive components.

Table 4-1. Rosemount™ 3051N Troubleshooting Chart

Symptom	Corrective actions
Milliamp Reading Is Zero	Check if power polarity is reversed.
	Verify voltage across terminals (should be 10 to 55 V dc).
	Check for bad diode in terminal block.
Transmitter Not Communicating with HART® Communicator	Check power supply voltage at transmitter (minimum 10.5 V).
	Verify calibration settings (4 and 20 mA points)
	Check load resistance (250 Ω minimum).
	Check if unit is addressed properly.
Milliamp Reading Is Low or High	Check pressure variable reading for saturation.
	Check if output in alarm condition.
	Verify 4 and 20 mA range points.
	Perform 4–20 mA output trim.
No Response to Changes in Applied Pressure	Check test equipment.
	Check impulse piping for blockage.
	Check disabled span adjustment.
	Check if output in alarm condition.
Pressure Variable Reading Is Low or High	Check impulse piping for blockage.
	Check test equipment.
	Perform full sensor trim.
Pressure Variable Reading Is Erratic	Check impulse piping for blockage.
	Check damping.
	Check for EMF interference.

The Rosemount 3051N Smart Pressure Transmitter is supplied by Rosemount Nuclear Instruments, Inc. as a non-field repairable device to ensure its qualification status is maintained. The Rosemount 3051N must be returned to Rosemount Nuclear Instruments, Inc. (RNII) for repairs and/or failure analysis. Instructions for returning product follow. Any piece parts, if available, must be supplied by RNII to maintain the Rosemount 3051N qualification status.

4.2.1 Returning Rosemount products and materials

Authorization for return is required from Rosemount Nuclear Instruments Inc. prior to shipment. Contact Rosemount Nuclear Instruments, Inc. at (952) 949-5200 for details on obtaining Returned Material Authorization (RMA). **Rosemount Nuclear Instruments will not accept any returned material without Returned Material Authorization.** Materials returned without authorization are subject to be returned to the customer.

Materials returned for repair should be shipped (prepaid) to:

Rosemount Nuclear Instruments, Inc.
8200 Market Blvd
Chanhausen, MN 55317
USA

Appendix A Specifications and Reference Data

Nuclear specifications	page 41
Performance specifications	page 42
Functional specifications	page 43
Physical specifications	page 45
Materials of construction	page 45
Ordering information	page 47
Configuration information	page 48

A.1 Nuclear specifications

Qualified for nuclear use per IEEE Std 344-1987 and IEEE Std 323-1983 (mild environment) as documented in Rosemount Report D2001019.

A.1.1 Seismic

Table A-1. Seismic Specifications Summary

Model	Range code	During seismic accuracy ⁽¹⁾	Post seismic accuracy	Specified seismic maximum working pressure	Structural integrity	
3051ND	Differential	0 ⁽²⁾	1.5% of URL (adjustable damping ≥ 3.2 s)	0.25% of URL	750 psi (5,2 MPa)	Maintained throughout specified seismic disturbance
		1 ⁽³⁾	0.75% of URL (adjustable damping ≥ 1.6 s)	0.25% of span	2000 psi (13,8 MPa)	
		2 ⁽³⁾	0.75% of URL (adjustable damping ≥ 0.8 s)		3000 psi (20,7 MPa) (glass-filled TFE O-ring)	
		3	0.75% of URL		2000 psi (13,8 MPa) (EPR O-ring)	
		4	0.25% of URL			
5						
3051NG	Gauge	2 ⁽³⁾	0.75% of URL (adjustable damping ≥ 0.8 s)	Upper Range Limit		
		3	0.75% of URL			
		4	0.25% of URL			
5						
3051NA	Absolute	1	not specified		not specified	
		2	0.25% of URL		0.25% of span	
		3				
		4		3000 psia (20,7 MPa) (glass-filled TFE O-ring) 2000 psi (13,8 MPa) (EPR O-ring)		

1. User-adjustable damping set at ≥ 0.4 s unless otherwise noted.
2. Mounting bracket Option Code BS required for Range 0 specified "During Seismic Accuracy" performance.
3. Mounting bracket (Option Code B2, BS, or PM) required for specified "During Seismic Accuracy" performance.

A.1.2 Environmental

Performance to normal operating limits as described in the [Performance specifications](#) and [Functional specifications](#) sections of this manual.

A.1.3 Quality assurance program

In accordance with 10CFR50 Appendix B, ISO 9001:2008

A.1.4 Nuclear cleaning

To <1 ppm chloride content

A.1.5 Hydrostatic testing

Model	Range code	Hydrostatic test pressure ⁽¹⁾
3051ND	0	750 psi
	1	2000 psi
	2-5	4200 psi
3051NG	2-5	150% of maximum working pressure ⁽²⁾
3051NA	1-4	

1. Process O-ring Code A (glass-filled TFE).
2. Maximum Working Pressure equals upper range limit (URL).

A.2 Performance specifications

Based upon zero-based calibrations, reference conditions, 4–20mA analog output, and digital trim values equal to the span setpoints

A.2.1 Reference accuracy

Includes hysteresis, terminal-based linearity, and repeatability⁽¹⁾

Rosemount 3051ND

Range code	Reference accuracy
0	± 0.10% calibrated span from 1:1 to 2:1 RDF ± 0.05% upper range limit from 2:1 to 30:1 RDF
1	± 0.10% calibrated span from 1:1 to 15:1 RDF ± (0.005% URL + 0.025% span) from 15:1 to 50:1 RDF
2 – 5	± 0.075% calibrated span from 1:1 to 10:1 RDF ± (0.005% URL + 0.025% span) from 10:1 to 100:1 RDF

Rosemount 3051NG

Range code	Reference accuracy
2 – 5	± 0.075% calibrated span from 1:1 to 10:1 RDF ± (0.005% URL + 0.025% span) from 10:1 to 100:1 RDF

Rosemount 3051NA

Range code	Reference accuracy
1 – 4	± 0.075% calibrated span from 1:1 to 10:1 RDF ± (0.0075% URL) from 10:1 to 100:1 RDF

A.2.2 Drift

Rosemount 3051ND, NG, NA

Range code	Drift
1	± (0.2% URL + 0.2% span) for 30 months
2 – 5	± 0.2% URL for 30 months

1. RDF = Range Down Factor = URL / Calibrated Span.
2. Exposure of isolating diaphragms to process temperatures above 185 °F (85 °C), but below 250 °F (121 °C), produces a temperature effect of ± 1.0% of calibrated span in addition to the effects listed.

A.2.3 Ambient temperature effect⁽¹⁾⁽²⁾

Rosemount 3051ND/NG

Range code	Ambient temperature effect per 50° F (28° C)
0	± (0.25% URL + 0.05% span)
1	± (0.1% URL + 0.25% span) from 1:1 to 30:1 RDF ± (0.14% URL + 0.15% span) from 30:1 to 50:1 RDF
2 – 5	± (0.0125% URL + 0.0625% span) from 1:1 to 5:1 ± (0.025% URL + 0.125% span) from 5:1 to 100:1

Rosemount 3051NA

Range code	Ambient temperature effect per 50° F (28° C)
1 – 4	± (0.025% URL + 0.125% span) from 1:1 to 30:1 ± (0.035% URL + 0.125% span) from 30:1 to 100:1

A.2.4 Overpressure effect

Maximum zero shift after overpressure equal to maximum working pressure

Rosemount 3051ND

Range code	Overpressure effect
0 – 3	± 0.5% URL
4 – 5	± 3.0% URL

Rosemount 3051NG

Range code	Overpressure effect
2 – 4	± 0.25% URL
5	± 0.30% URL

Rosemount 3051NA

Range code	Overpressure effect
1 – 4	± 0.05% URL

A.2.5 Static pressure effect

Rosemount 3051ND

Zero Error (can be calibrated out at line pressure) Per 1000 psi (6,9 MPa) line pressure

Range code	Static pressure zero effect ⁽¹⁾
0 ⁽²⁾	± 0.125% URL for Ps ≤ 750 psi (5,2 MPa)
1	± 0.25% URL for Ps ≤ 2000 psi (13,8 MPa)
2, 3	± 0.05% URL for Ps ≤ 2000 psi (13,8 MPa) ± [0.1 + 0.1 (Ps-2000) / 1000]% URL for Ps > 2000 psi (13,8 MPa) ≤ 3626 psi (25 MPa)
4, 5	± 0.1% URL for Ps ≤ 2000 psi (13,8 MPa) ± [0.2 + 0.2 (Ps-2000) / 1000]% URL for Ps > 2000 psi (13,8 MPa) ≤ 3626 psi (25 MPa)

1. Ps equals static line pressure applied.

2. Specification for Rosemount 3051N Range 0 is expressed in (% per 100 psi [689 KPa]).

Rosemount 3051ND

Span Error Per 1000 psi (6,9 MPa) line pressure

Range code	Static pressure span effect
0 ⁽¹⁾	± 0.15% input reading
1	± 0.40% input reading
2, 3	± 0.10% input reading
4, 5	± 0.20% input reading (uncertainty after calibration correction for systematic effects)

1. Specification for Rosemount 3051N Range 0 is expressed in [% per 100 psi (689 KPa)] up to 750 psi (5 171 KPa).

A.2.6 Power supply effect

Less than ±0.005% of calibrated span per volt for RDF ≤ 10

A.2.7 Load effect

No load effect other than change in voltage supplied to the transmitter

A.2.8 Mounting position effect

Rosemount 3051ND/NG

Zero shifts up to ±1.25 in H₂O (0,31 KPa), which can be calibrated out; no span effect

Rosemount 3051NA

Zero shifts up to 2.5 in H₂O (63,5 mm), which can be calibrated out; no span effect

A.3 Functional specifications

A.3.1 Service

Liquid, gas, or vapor

A.3.2 Output

4–20 mA, user-selectable for linear or square root output; digital signal based on HART® Protocol

A.3.3 Power supply

Load limitations

Maximum loop resistance is determined by the voltage level of the external power supply, as described by:

Max. Loop Resistance = 43.5 (Power Supply Voltage – 10.5) ohms

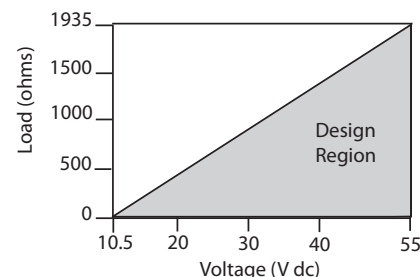

Communication requires a minimum loop resistance of 250 ohms.

A.3.4 Temperature limits

Ambient

0 to 185 °F (-18 to 85 °C)

with meter option:

0 to 175 °F (-18 to 80 °C)

Process⁽¹⁾⁽²⁾⁽³⁾

0 to 250 °F (-18 to 121 °C) coplanar flange

0 to 300 °F (-18 to 149 °C) traditional flange

Storage

0 to 212 °F (-18 to 100 °C)

with meter option:

0 to 185 °F (-18 to 85 °C)

1. Process temperatures above 185 °F (85 °C) require derating the ambient temperature limits by 1.5 °F per degree above 185 °F.
2. 220 °F (104 °C) limit in vacuum service; 130 °F (54 °C) for pressures below 0.5 psia
3. EPR O-ring is limited to 150 °F (66 °C) process temperature.

A.3.5 Span and zero, zero elevation, and suppression

Zero and span values can be set anywhere within the range limits stated in Table A-2 and Table A-3, providing sensor limits are not exceeded.

Span must be greater than or equal to the minimum span stated in Table A-2 and Table A-3.

Table A-2. Rosemount 3051ND and 3051NG Range and Sensor Limits

Range	Minimum span	Range and sensor limits		
	Rosemount 3051ND/NG	Upper (URL)	Lower (LRL)	
			Rosemount 3051ND	Rosemount 3051NG
0	0.1 inH ₂ O (25 Pa)	3.0 inH ₂ O (750 Pa)	-3.0 inH ₂ O (-750 Pa)	N/A
1	0.5 inH ₂ O (0,12 kPa)	25 inH ₂ O (6,22 kPa)	-25 inH ₂ O (-6,22 kPa)	N/A
2	2.5 inH ₂ O (0,62 kPa)	250 inH ₂ O (62,2 kPa)	-250 inH ₂ O (-62,2 kPa)	-250 inH ₂ O (-62,2 kPa)
3	10 inH ₂ O (2,48 kPa)	1000 inH ₂ O (248 kPa)	-1000 inH ₂ O (-248 kPa)	0.5 psia (3,5 kPa abs)
4	3 psi (20,7 kPa)	300 psi (2 070 kPa)	-300 psi (-2 070 kPa)	0.5 psia (3,5 kPa abs)
5	20 psi (138 kPa)	2000 psi (13 800 kPa)	-2000 psi (-13 800 kPa)	0.5 psia (3,5 kPa abs)

Table A-3. Rosemount 3051NA Range and Sensor Limits

Range	Minimum span	Range and sensor limits	
		Upper (URL)	Lower (LRL)
1	0.3 psia (2,07 kPa abs)	30 psia (206,8 kPa abs)	0 psia (0 kPa abs)
2	1.5 psia (10,34 kPa abs)	150 psia (1 034,2 kPa abs)	0 psia (0 kPa abs)
3	8 psia (55,16 kPa abs)	800 psia (5 515,8 kPa abs)	0 psia (0 kPa abs)
4	40 psia (275,8 kPa abs)	4000 psia (27 580 kPa abs)	0 psia (0 kPa abs)

A.3.6 Humidity limits

0-100% relative humidity

A.3.7 Volumetric displacement

Less than 0.005 in³ (0,08 cm³)

A.3.8 Turn-on time

Two seconds maximum

A.3.9 Response time

Dead time (T_d)

Maximum dead time before analog output reacts to step change in input = 0.1 seconds

Update rate

20 times per second minimum

Minimum time constant (T_c)

At 70 °F, with minimum damping setting

Range code	Minimum time constant (T _c) including dead time (T _d)
0	≤ 1.0 seconds

At 70 °F, with minimum damping setting

Range code	Minimum time constant (T _c) including dead time (T _d)
1	≤ 0.5 seconds
2 - 5	≤ 0.2 seconds

Adjustable damping

Time constant on analog output is incrementally adjustable from the minimum values stated above to 25.6 seconds nominal.

Figure A-1. Typical Smart Transmitter Response Time

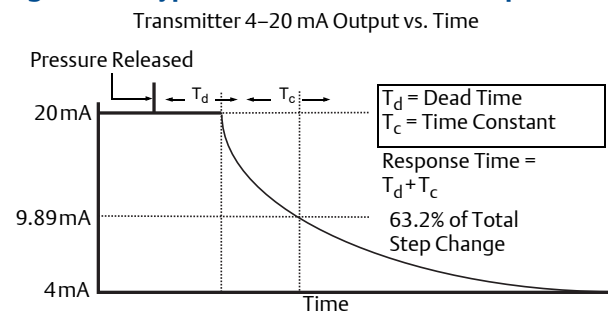

A.3.10 Maximum working pressure⁽¹⁾⁽²⁾

Rosemount 3051ND

Static pressure limit

Rosemount 3051NG and Rosemount 3051NA

Upper range limit

A.3.11 Static pressure limits

Operates within specifications between static line pressures stated below

Rosemount 3051ND only

Range code	Static pressure limits
0	0.5 psia to 750 psig (3,4 kPa abs to 5,2 MPa)
1	0.5 psia to 2000 psig (3,4 kPa abs to 13,8 MPa)
2 – 5 ⁽¹⁾	0.5 psia to 3626 psig (3,4 kPa abs to 25 MPa)

1. EPR process O-ring (Code B) is limited to 2000 psi maximum working pressure.

A.3.12 Overpressure limits

Transmitters withstand the following overpressure without damage:

Rosemount 3051ND/NG

Range code	Overpressure limits
0	750 psig (5,2 MPa)
1	2000 psig (13,8 MPa)
2 – 5 ⁽¹⁾	3626 psig (25 MPa)

1. EPR process O-ring (Code B) is limited to 2000 psi maximum working pressure.

Rosemount 3051NA

Range code	Overpressure limits
1	120 psia (827 kPa)
2	300 psia (2 070 kPa)
3	1600 psia (11 030 kPa)
4 ⁽¹⁾	6000 psia (41 370 kPa)

1. EPR process O-ring (Code B) is limited to 2000 psi maximum working pressure.

A.3.13 Burst pressure

Minimum burst pressure is 10,000 psig (69 MPa).

1. EPR process O-ring (Code B) is limited to 2000 psi maximum working pressure.
2. See Table A-2 for specified Seismic Maximum Working Pressure.

A.4 Physical specifications

A.4.1 Materials of construction

Isolating diaphragms

316L SST

Drain/vent valves

316 SST

Process flanges

CF-8M (cast version of 316 SST)

Process O-rings

Glass-filled TFE, Ethylene propylene (optional)

Fill fluid

Silicone oil

Flange bolts

Plated carbon steel, per ASTM A449, Type 1 or SAE J492 Grade 5 (austenitic 316 SST per ASTM F593 for the Rosemount 3051N Range Code 0)

Electronics housing

Low-copper aluminum with polyurethane paint, or CF-8M (cast version of 316 SST)

Non-wetted O-rings

Ethylene propylene elastomer

Sensor module housing

CF-3M (cast version of 316L SST per ASTM-A743)

Mounting bracket

AISI 1010 steel or JIS G3131 SPHC P/O Steel with polyurethane paint (Option Code B2), 304 SST per ASTM 554 (Option Code B4), 316L SST (Option Code BS), or SST (Option Code PM)

Mounting bolts (bracket-to-transmitter)

Carbon steel, per ASTM A449, Type 1 or SAE J429 Grade 5 (Option Code B2, BS, PM), 316 SST per ASTM F-593 (Option Code B4)

Process connections

1/4-18 NPT

Electrical connections

1/2-14 NPT conduit with screw terminals

Weight

Transmitter without options: 6.0 lb (2,7 kg) (see table below for additional weights)

Option code	Description	Add:
J	Stainless steel housing	3.1 lb (1.4 kg)
H2	Traditional flange	2.4 lb (1.1 kg)
M5	LCD display meter for aluminum housing	0.5 lb (0.2 kg)
M6	LCD display meter for SST housing	1.25 lb (0.6 kg)
B2	Carbon steel panel mounting bracket for traditional flange	2.3 lb (1.0 kg)
B4	SST mounting bracket for coplanar flange	1.0 lb (0.5 kg)
BS	Universal SST panel bracket for traditional flange	3.4 lb (1.5 kg)
PM	2-in. pipe mount assembly for traditional flange	6.8 lb (3.0 kg)

A.5 Ordering information

Table A-4. Rosemount 3051N⁽¹⁾ Differential, Gage, and Absolute Pressure Transmitters Ordering Information

— = Not Applicable • = Applicable

Model	Transmitter type (select one)			ND	NG	NA	
3051ND	Differential pressure transmitter			•	—	—	
3051NG	Gage pressure transmitter			—	•	—	
3051NA	Absolute pressure transmitter			—	—	•	
Code	Pressure ranges (Range/min. span)			ND	NG	NA	
	Rosemount 3051ND	Rosemount 3051NG	Rosemount 3051NA				
0 ⁽²⁾	-3 to 3 inH ₂ O/0.1 inH ₂ O (-747 to 747 Pa/25 Pa)	Not applicable	Not applicable	•	—	—	
1	-25 to 25 inH ₂ O/0.5 inH ₂ O (-6,22 to 6,22 kPa/0,12 kPa)	Not applicable	0 to 30 psia/0.3 psia (0 to 207 kPa/2,1 kPa)	•	—	•	
2	-250 to 250 inH ₂ O/2.5 inH ₂ O (-62,2 to 62,2 kPa/0,6 kPa)	-250 to 250 inH ₂ O/2.5 inH ₂ O (-62,2 to 62,2 kPa/0,6 kPa)	0 to 150 psia/1.5 psia (0 to 1 034 kPa/10,34 kPa)	•	•	•	
3	-1000 to 1000 inH ₂ O/10 inH ₂ O (-248 to 248 kPa/2,5 kPa)	-393 to 1000 inH ₂ O/10 inH ₂ O (-101 to 249 kPa/2,5 kPa)	0 to 800 psia/8 psia (0 to 5 516 kPa/55,16 kPa)	•	•	•	
4	-300 to 300 psi/3 psi (-2 070 to 2 070 kPa/20,7 kPa)	-14.2 to 300 psig/3 psi (-101 to 2 070 kPa/20,7 kPa)	0 to 4000 psia/40 psia (0 to 27 580 kPa/276 kPa)	•	•	•	
5	-2000 to 2000 psi/20 psi (-13 800 to 13 800 kPa/138 kPa)	-14.2 to 2000 psig/20 psi (-101 to 13 800 kPa/138 kPa)	Not applicable	•	•	—	
Note: Rosemount 3051NG lower range limit varies with atmospheric pressure.							
Code	Output			ND	NG	NA	
A	4–20 mA with digital signal based on HART Protocol						
Code	Materials of construction			ND	NG	NA	
	Process flange type	Flange material	Drain/vent				
2	Coplanar	SST	SST	•	•	•	
0	Alternate flange – See Option Code H2			•	•	•	
Code	Isolating diaphragm			ND	NG	NA	
2	316L SST						
Code	Process O-ring			ND	NG	NA	
A	Glass-filled TFE						
B ⁽³⁾	Ethylene Propylene (EPR)			•	•	•	
Code	Fill fluid			ND	NG	NA	
1	Silicone oil						
Code	Housing material	Conduit entry size			ND	NG	NA
A	Polyurethane-covered aluminum	½–14 NPT					
J	SST	½–14 NPT			•	•	•

Table A-4. Rosemount 3051N⁽¹⁾ Differential, Gage, and Absolute Pressure Transmitters Ordering Information

Code	Alternate flange options (requires materials of construction Code 0)			
H2	Traditional flange, 316 SST, SST drain/vent	•	•	•
Code	Mounting bracket options			
B2	Traditional flange bracket for panel mounting, CS bolts	•	•	•
B4	Coplanar flange bracket for panel mounting, all SST	•	•	•
BS	Universal traditional flange bracket for panel mounting (SST), CS bolts	•	•	•
PM	Traditional flange bracket for pipe mounting, all SST	•	•	•
Code	Meters (optional)			
M5	LCD display meter for aluminum housing (Housing Material Code A only)	•	•	•
M6	LCD display meter for SST housing (Housing Material Code J only)	•	•	•
Typical Rosemount Number: 3051ND 2 A 2 2 A 1 A B4				

1. All Rosemount 3051N Transmitters are provided as standard with transient protection block (TI) and cleaning for < 1 PPM chloride.
2. Rosemount 3051ND0 is available only with Process Flange Code 0 (Alternate Flange H2), O-ring Code A, and stainless steel process flange bolting.
3. EPR process O-ring is limited to 2000 psi maximum working pressure and 150 °F (66 °C) process temperature.

Note

Mounting bracket option code must be specified last in the Rosemount model number even if optional meter is ordered.

A.6 Configuration information

Transmitter is shipped as follows (unless different calibration is specified).

Table A-5. Engineering Units

Differential/gage	inH ₂ O (Range 0, 1, 2, and 3) psi (Range 4 and 5)
Absolute	psi (all ranges)
4 mA	0 (engineering units above)
20 mA	Upper range limit
Output	Linear
Flange type	Specified Rosemount code option
Flange material	Specified Rosemount code option
O-ring material	Specified Rosemount code option
Drain/vent	Specified Rosemount code option
Integral meter	Installed or none
Alarm	Upscale
Software tag	(blank)

A.6.1 Rosemount 3051N 4-20 mA/HART Output Smart Pressure Transmitters Typical Configuration Data Worksheet

Software Tag: | _ | _ | _ | _ | _ | _ | _ | _ | _ | _ |

Output information: (software selectable)

4 mA = _____ 0?

20 mA = _____ Upper Range Limit ?

Pressure Units = <input type="checkbox"/> inH ₂ O? ⁽²⁾	<input type="checkbox"/> psi? ⁽³⁾	<input type="checkbox"/> Pa	<input type="checkbox"/> ftH ₂ O
<input type="checkbox"/> inHg	<input type="checkbox"/> bar	<input type="checkbox"/> kPa	<input type="checkbox"/> g/cm ²
<input type="checkbox"/> mbar	<input type="checkbox"/> Torr	<input type="checkbox"/> mmH ₂ O	<input type="checkbox"/> inH ₂ O at 4 °C
<input type="checkbox"/> Atm	<input type="checkbox"/> kg/cm ²	<input type="checkbox"/> mmHg	<input type="checkbox"/> mmH ₂ O at 4 °C

Output = Linear? Square root (For DP transmitters only)

Damping⁽⁴⁾ = 0.00 seconds 0.05 seconds 0.10 seconds 0.20 seconds 0.40 seconds?

0.80 seconds 1.60 seconds 3.20 seconds 6.4 seconds 12.8 seconds

25.6 seconds

Key to Symbols
? = Typical Factory Default Value⁽¹⁾

Transmitter information (software selectable):

Descriptor: | _ | _ | _ | _ | _ | _ | _ | _ | _ | _ | _ | _ | _ | _ | _ | _ |

(16 characters)

Message: | _ | _ | _ | _ | _ | _ | _ | _ | _ | _ | _ | _ | _ | _ | _ | _ |

(32 characters)

Date: | _ | _ | _ | / | _ | _ | _ | / | _ | _ | _ |

Day Month Year

Local Span and Zero: Enabled? Disabled

LCD display meter configuration
(software adjustable – M5 or M6 option must be specified in Rosemount number)

Meter Display Type:

<input type="checkbox"/> Eng. Units only	<input type="checkbox"/> Alternate Eng. Units and % of Range ?
<input type="checkbox"/> % of Range only	<input type="checkbox"/> Alternate Eng. Units and Custom Display
<input type="checkbox"/> Custom Display only	<input type="checkbox"/> Alternate % of Range and Custom Display

Custom Display Configuration (must be filled out if Custom Display is selected as meter type):

Decimal Point Position (fixed)
Indicate decimal point location X₀ X₀ X₀ X₀ X₀

Enter Lower Range Value (decimal point must be in the same position as specified above)
(circle sign) + - | _ | _ | ◊ | _ | _ | ◊ | _ | _ | ◊ | _ | _ | ◊ | Default is +000.00

Enter Upper Range Value (Decimal point must be in the same position as specified above.)
(circle sign) + - | _ | _ | ◊ | _ | _ | ◊ | _ | _ | ◊ | _ | _ | ◊ | Default is +100.00

Custom Units
Available characters: A-Z, 0-9, /, *, %, (blank)

| _ | _ | _ | _ | _ | Default is %RNGE

Custom Display Transfer Function (Independent of Analog Output)

Linear?

Square Root

1. Default values may be different outside the U.S.A. Consult your Rosemount Representative for details.
2. inH₂O for ND/NG Ranges 0, 1, 2, and 3.
3. psi for ND/NG Ranges 4 and 5, all NA ranges.
4. Rosemount 3051NDO default damping is 3.2 seconds. Rosemount 3051ND1, with calibrations below 2.5 inH₂O (0,62 kPa) have damping set at 3.2 seconds.

Hardware selectable information
Alarm Option: <input type="radio"/> High? <input type="radio"/> Low
Transmitter Security: <input type="radio"/> Off? <input type="radio"/> On
Signal selection (software selectable):
<input type="checkbox"/> 4–20 mA with simultaneous digital signal based on HART Protocol? Note: This is the only signal selection that has been evaluated for use in safety related applications.

Figure A-2. Rosemount 3051N Exploded View (with Coplanar Process Flange)

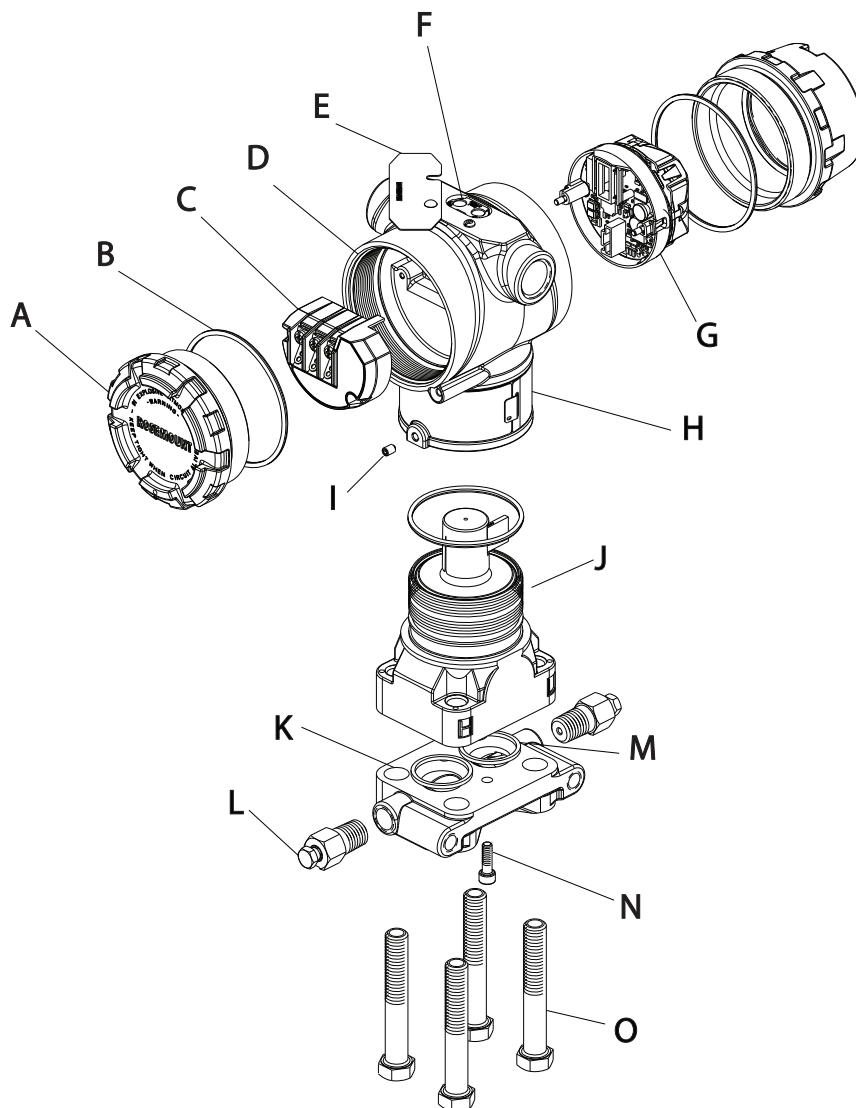

- | | | |
|--------------------------------|---|--|
| A. Cover | G. Electronics board | K. Coplanar flange |
| B. Cover O-ring | H. Name plate | L. Drain/vent valve |
| C. Terminal block | I. Housing rotation set screw (180 degree maximum rotation without further disassembly) | M. Process O-ring |
| D. Electronics housing | J. Sensor module | N. Flange alignment screw (not pressure retaining) |
| E. Configuration button cover | | O. Flange bolts |
| F. Local configuration buttons | | |

Appendix B Options

Overview	page 51
Safety messages	page 51
LCD display meter	page 51
Mounting brackets	page 56
Transient protection terminal block (T1)	page 57

B.1 Overview

The options available with the Rosemount™ 3051N can ease installation, improve the security of control systems, and simplify use. Included in this section is a description of LCD display meter diagnostic messages. The Rosemount 3051N LCD display meter option is qualified to maintain structural integrity throughout the specified seismic event. Operation of the LCD display meter is not addressed for use during or after a seismic event.

B.2 Safety messages

Procedures and instructions in this section may require special precautions to ensure the safety of the personnel performing the operations. Information that raises potential safety issues is indicated by a warning symbol (⚠). Refer to the following safety messages before performing an operation preceded by this symbol.

⚠ WARNING

Explosions can result in death or serious injury.

- Do not remove the instrument cover in explosive environments when the circuit is alive.
- Before connecting a communicator in an explosive atmosphere, make sure the instruments in the loop are installed in accordance with intrinsically safe or nonincendive field wiring practices.

Electrical shock can result in death or serious injury.

- Avoid contact with the leads and terminals.
-

B.3 LCD display meter

The LCD display meter provides local indication of the output and abbreviated diagnostic messages governing transmitter operation. The meter is located on the electronics module side of the transmitter, maintaining direct access to the signal terminals. An extended cover is required to accommodate the meter.

The meter features a two-line display with five digits for reporting the process variable on the top line and six characters for displaying engineering units on the bottom line. The LCD display meter can also display flow and level scales. The meter uses both lines to display diagnostic messages. The meter can be configured to display the following information:

- Engineering units
- Percent of range
- User-configurable LCD display scale
- Alternating between any two of the above

B.3.1 Custom meter configuration

The user-configurable scale is a feature that enables the LCD display meter to display flow, level, or custom pressure units. The meter can be configured using a HART® Communicator (see [Table C-1 on page 62](#)).

The user-configurable scale feature can define:

- Decimal point position
- Upper range values
- Lower range values
- Engineering units
- Transfer function

To configure the meter with a HART Communicator, perform the following procedure:

-  1. Connect the communicator to the transmitter. Before connecting a communicator in an explosive atmosphere, make sure the instruments in the loop are installed according to intrinsically safe or nonincendive field wiring practices.

HART Fast Keys	1, 3, 7, 2
-----------------------	------------

2. From the *ONLINE* screen, select **1 Device Setup > 3 Basic Setup > 7 Meter Options > 2 Custom Meter Setup**.
3. To specify decimal point position:
 - a. Select **1 Sel dec pt pos**. Select the decimal point representation that will provide the most accurate output for your application. For example, when outputting between 0 and 75 GPM, select **XX.XXX**.
 - b. Go to [Step 8](#).
4. To specify a custom upper range value:
 - a. Select **2 CM Upper Value**. Enter the value the transmitter should read at the 20 mA point.
 - b. Go to [Step 8](#).
5. To specify a custom lower range value:
 - a. Select **3 CM Lower Value**. Enter the value the transmitter should read at the 4 mA point.
 - b. Go to [Step 8](#).
6. To define custom units:
 - a. Select **4 CM Units**. Enter the custom units (five characters maximum) the meter should display.
 - b. Go to [Step 8](#).
7. To select the transmitter transfer function for the meter:
 - a. Select **5 CM xfer fnct**. Enter the transmitter transfer function for the meter. Select **sq root** to display flow units. The custom meter transfer function is independent of the analog output transfer function.
8. Select **Send (F2)** to upload the configuration to the transmitter.

 See “[Safety messages](#)” on [page 51](#) for warning

Figure B-1. Exploded View of the Rosemount 3051N with Optional LCD Display Meter

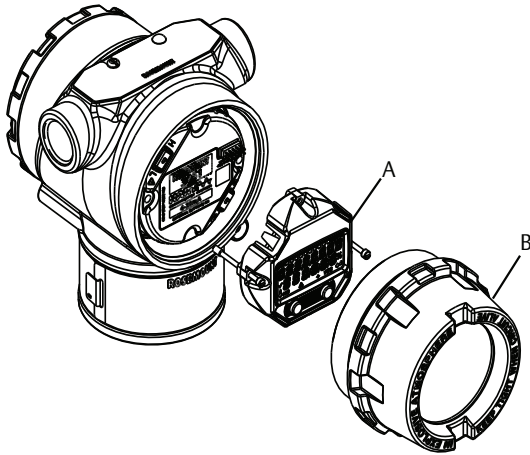

A. LCD display
B. Extended cover

B.3.2 Installing the meter

For transmitters ordered with the LCD display meter, the meter is shipped installed. Installing the meter on an existing Rosemount 3051N Transmitter requires a small instrument screwdriver and the meter kit (when the kit is made available by Rosemount Nuclear Instruments, Inc.).

To maintain the Rosemount 3051N qualification status, any piece parts for the Rosemount 3051N (if available) must be supplied by RNII.

The meter kit includes:

- One LCD display meter assembly
- One extended cover with O-ring installed
- Two nylon standoffs
- Two captive screws
- One 10-pin interconnection header

Use the following procedure and [Figure B-1](#) to install the LCD display meter.

1. If the transmitter is installed in a loop, then secure the loop and disconnect power.
- ⚠ 2. Remove the transmitter cover opposite the field terminal side. Do not remove the instrument covers in explosive environments when the circuit is alive.
3. Remove the failure mode and alarm jumpers from the electronics module and insert them in their new positions above and below the meter readout on the meter assembly.
4. Insert the interconnection header in the ten-pin socket exposed by removal of the jumpers.
5. Remove the two captive screws from the electronics module.
 - a. Loosen the screws to release the module.
 - b. Pull out the screws until they are stopped by the captive thread inside of the circuit board standoffs.
 - c. Continue loosening the screws and remove them.
6. If necessary, rotate the electronics housing up to 180 degrees (left or right) to improve field access or to better view the LCD display meter. To rotate the housing:
 - a. Loosen the housing rotation set screw using a $\frac{9}{64}$ -in. hex wrench.
 - b. Turn the housing up to 180 degrees to the left or right of its original (as shipped) position.

⚠ See “Safety messages” on page 51 for warning

Note

Do not rotate the housing more than 180 degrees. Over-rotation will sever the electrical connection between the sensor module and the electronics module.

- c. Retighten the housing rotation set screw.
7. Decide which direction to orient the meter. Insert the long meter screws into the two holes on the meter assembly that coincide with the holes on the electronics module. The meter can be installed in 90-degree increments for easy viewing. Position one of the four connectors on the back of the meter assembly to accept the interconnection header.
8. Attach the meter assembly to the electronics module by threading the screws into the captive threads and attaching the meter assembly to the interconnection pins. Tighten the screws to secure the meter assembly and electronics board in place.
9. Attach and tighten the extended cover. Transmitter covers must be fully engaged to meet explosion proof requirements and to achieve the proper environmental seal.

Note the following LCD display temperature limits:

Operating: 0 to 175 °F (–20 to 80 °C)

Storage: 0 to 185 °F (–40 to 85 °C)

Note

Electronics are able to verify alarm current levels. An alarm level test is recommended before returning the transmitter to service (see “Alarm level verification” on page 4).

Figure B-2. Rosemount 3051N with Optional LCD Display Meter



B.3.3 Diagnostic messages

In addition to the output, the LCD display meter displays abbreviated operation, error, and warning messages for troubleshooting the transmitter. Messages appear according to their priority, with normal operating messages appearing last. To determine the cause of a message, use a HART Communicator to further interrogate the transmitter. A description of each LCD display diagnostic message follows.

Error

Error messages appear on the LCD display meter display to inform you of serious problems effecting the operation of the transmitter. The meter displays an error message until the error condition is corrected, and the analog output is driven to the specified alarm level. No other transmitter information is displayed during an alarm condition.

FAIL

The transmitter CPU board and the sensor module are incompatible. If this message is encountered, contact Rosemount Nuclear Instruments, Inc. at (952) 949-5200 for assistance.

FAIL MODULE

The sensor module is disconnected or is malfunctioning. Verify the sensor module ribbon cable is connected to the back of the electronics board. If the ribbon cable is properly connected, there is a problem within the sensor module. Possible sources of problems include:

- Pressure or temperature updates are not being received in the sensor module.
- A non-volatile memory fault that will effect transmitter operation has been detected in the module by the memory verification routine.

Some non-volatile memory faults are user-addressable. Use a HART Communicator to diagnose the error and determine if it is repairable. Any error message that ends in “*FACTORY*” is not repairable. In cases of non user-addressable errors, the transmitter must be replaced. Contact Rosemount Nuclear Instruments Inc. at (952) 949-5200 if needed for assistance.

FAIL ELECT

The transmitter electronics board is malfunctioning due to an internal fault. Some of the *FAIL ELECT* errors are user-addressable. Use a HART Communicator to diagnose the error and determine if it is repairable. Any error message that ends in “*FACTORY*” is not repairable. In cases of non user-repairable errors, the transmitter must be replaced. Contact Rosemount Nuclear Instruments Inc. at (952) 949-5200 if needed for assistance.

FAIL CONFIG

A memory fault has been detected in a location that could affect transmitter operation, and is user-addressable. To correct this problem, use a HART Communicator to interrogate and reconfigure the appropriate portion of the transmitter memory. Contact Rosemount Nuclear Instruments Inc. at (952) 949-5200 if needed for assistance.

B.3.4 Warnings

Warnings appear on the LCD display meter display to alert of user-repairable problems with the transmitter, or current transmitter operations. Warnings appear alternately with other transmitter information until the warning condition is corrected or the transmitter completes the operation that warrants the warning message.

PRESS LIMIT

The process variable read by the transmitter is outside of the transmitter’s range.

TEMP LIMIT

The secondary temperature variable read by the transmitter is outside of the transmitter’s range.

CURR SATURD

The pressure read by the module is outside of the specified range, and the analog output has been driven to saturation levels. See “[Failure mode alarm](#)” on page 4.

LOOP TEST

A loop test is in progress. During a loop test or 4–20 mA trim, the analog output is set to a fixed value. The meter display alternates between the current selected in milliamps and “*LOOP TEST.*”

XMTR INFO

A non-volatile memory fault has been detected in the transmitter memory by the memory verification routine. The memory fault is in a location containing transmitter information. To correct this problem, use a HART Communicator to interrogate and reconfigure the appropriate portion of the transmitter memory. This warning does not affect the transmitter operation. Contact Rosemount Nuclear Instruments Inc. at (952) 949-5200 if needed for assistance.

B.3.5 Operation

Normal operation messages appear on the LCD display meter to confirm actions or inform you of transmitter status. Operation messages are displayed with other transmitter information, and warrant no action to correct or alter the transmitter settings.

ZERO PASS

The zero value, set with the local zero adjustment button, has been accepted by the transmitter, and the output should change to 4 mA.

ZERO FAIL

The zero value, set with the local zero adjustment button, exceeds the maximum rangedown allowed for a particular range, or the pressure sensed by the transmitter exceeds the sensor limits.

SPAN PASS

The span value, set with the local span adjustment button, has been accepted by the transmitter, and the output should change to 20 mA.

SPAN FAIL

The span value, set with the local span adjustment button, exceeds the maximum rangedown allowed for a particular range, or the pressure sensed by the transmitter exceeds the sensor limits.

LOCAL DSBLD

This message appears during reranging with the integral zero and span buttons and indicates that the transmitter local zero and span adjustments have been disabled. The adjustments may have been disabled by the transmitter security jumper on the transmitter circuit board or through software commands from the HART Communicator. See “[Transmitter security](#)” on [page 4](#) for information on the position of the security jumper, removal of local zero and span buttons, and for information on the software lockout.

WRITE PROTECT

This message appears if attempting to change the transmitter configuration data while the security jumper is in the *ON* position. See “[Transmitter security](#)” on [page 4](#) for more information about the security jumper.

B.4 Mounting brackets

Optional mounting brackets available with the Rosemount 3051N facilitate mounting to a panel. The standard bracket (B4) for use with the coplanar flange is stainless steel with stainless steel bolts. Refer to [Figure 3-2 on page 28](#) for dimensions and mounting configurations.

Option B2 is polyurethane painted carbon steel bracket designed for use with the traditional flange (H2). The B2 bracket is supplied with carbon steel bolts and supports panel mounting. Refer to [Figure 3-4 on page 30](#) for dimensions and mounting configurations.

Option BS is a 316LSST bracket supplied with carbon steel bolts and designed for use in panel mounting with the traditional flange (H2). It is the same bracket used on other RNII nuclear qualified transmitters, including the Rosemount 1153 series D and Rosemount 1154. Refer to [Figure 3-4 on page 30](#) for dimensions and mounting configurations.

Option PM is a SST pipe mount bracket assembly designed for use in pipe mounting the traditional flange (H2). It is the same bracket used on other RNII nuclear qualified transmitters, including the Rosemount 1154 Series H.

When installing the transmitter to the optional mounting brackets, torque the bolts to 21 foot-pounds. See “[Mounting](#)” on [page 31](#) for additional mounting considerations.

B.4.1 Traditional flange (H2)

The traditional flange option converts the mounting configuration of the Rosemount 3051N to one similar to traditional style transmitters. This allows the Rosemount 3051N to replace traditional transmitters without changing existing manifolds, impulse piping, or bracket arrangements. The traditional flange also allows a higher process temperature at the process ports (300 °F [149 °C]) because of its ability to dissipate heat.

The traditional flange fits most existing mounting brackets. If a new bracket is required, use one of the bracket options described earlier. Figure B-3 shows the traditional flange.

Figure B-3. Typical Traditional Flange

Traditional flange and Rosemount 3051N

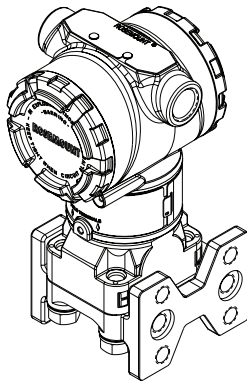

Traditional flange with drain/vents

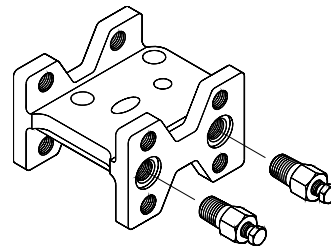

B.5 Transient protection terminal block (T1)

The standard transient protection terminal block increases the Rosemount 3051N Pressure Transmitter’s ability to withstand electrical transients. Rosemount 3051N Pressure Transmitters, with integral transient protection installed, meet the standard performance specifications as outlined in this product manual.

Note

Installation of the transient protection terminal block does not provide transient protection unless the Rosemount 3051N Transmitter case is properly grounded. See “Grounding the transmitter case” on page 36 for grounding information.

Figure B-4. Transient Protection Terminal Block (T1)

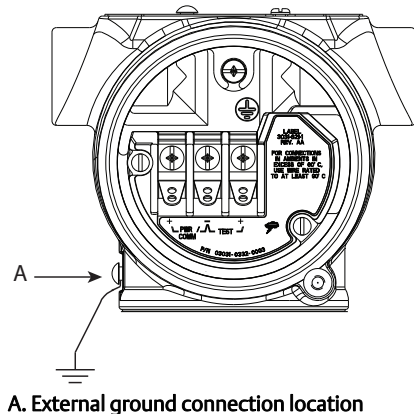

This page intentionally left blank

Appendix C HART® Communicator

Introduction	page 59
Safety messages	page 60
Connections and hardware	page 63
Menus and functions	page 65
Diagnostic messages	page 67

C.1 Introduction

This appendix provides basic communicator information on the 275, 375, and 475 HART® Communicators when used with a Rosemount™ 3051N Smart Pressure Transmitter. The 275, 375, and 475 HART Communicators are not qualified, but may be used as Measurement and Test Equipment (MTE) as documented in Rosemount Report D2001019.

When the HART Communicator is referenced, it refers to the 275, 375, or 475 Field Communicator.

This brief appendix will familiarize you with the HART Communicator but is not meant to replace the HART Communicator User's Manual. For additional information on the HART Communicator, refer to the 275 HART Communicator Product Manual (publication number 00275-8026-0001), 375 User's Manual, or 475 User's Manual.

Note

The HART Communicator software may need updating to take advantage of all features of the Rosemount 3051N. If initiating communication with a Rosemount 3051N using a communicator that has a previous version of the transmitter Device Descriptors (DDs), the communicator will display the following message:

Notice: Upgrade software to access XMTR function. Continue with old description?

If **YES** is selected, the communicator will communicate properly with the transmitter using the existing Rosemount 3051N DDs. However, software features added since the revision of the DDs in the communicator will not be accessible. If **NO** is selected, the communicator will default to a generic transmitter functionality. Contact Rosemount Nuclear Instruments, Inc. at (952) 949-5200.

C.2 Safety messages

Procedures and instructions in this section may require special precautions to ensure the safety of the personnel performing the operations. Information that raises potential safety issues is indicated by a warning symbol (⚠). Refer to the following safety messages before performing an operation preceded by this symbol.

⚠ WARNING

Explosions can result in death or serious injury.

- Do not remove the transmitter covers in explosive environments when the circuit is alive.
- Before connecting a communicator in an explosive atmosphere, make sure the instruments in the loop are installed according to intrinsically safe or nonincendive field wiring practices.

If all field device status messages are ignored, every message from nuisance to critical will be ignored. Voltage measurements are for reference purposes only. Do not make critical process control decisions based upon this voltage.

FIGURE C-1. HART Communicator Typical Abbreviated Menu Tree

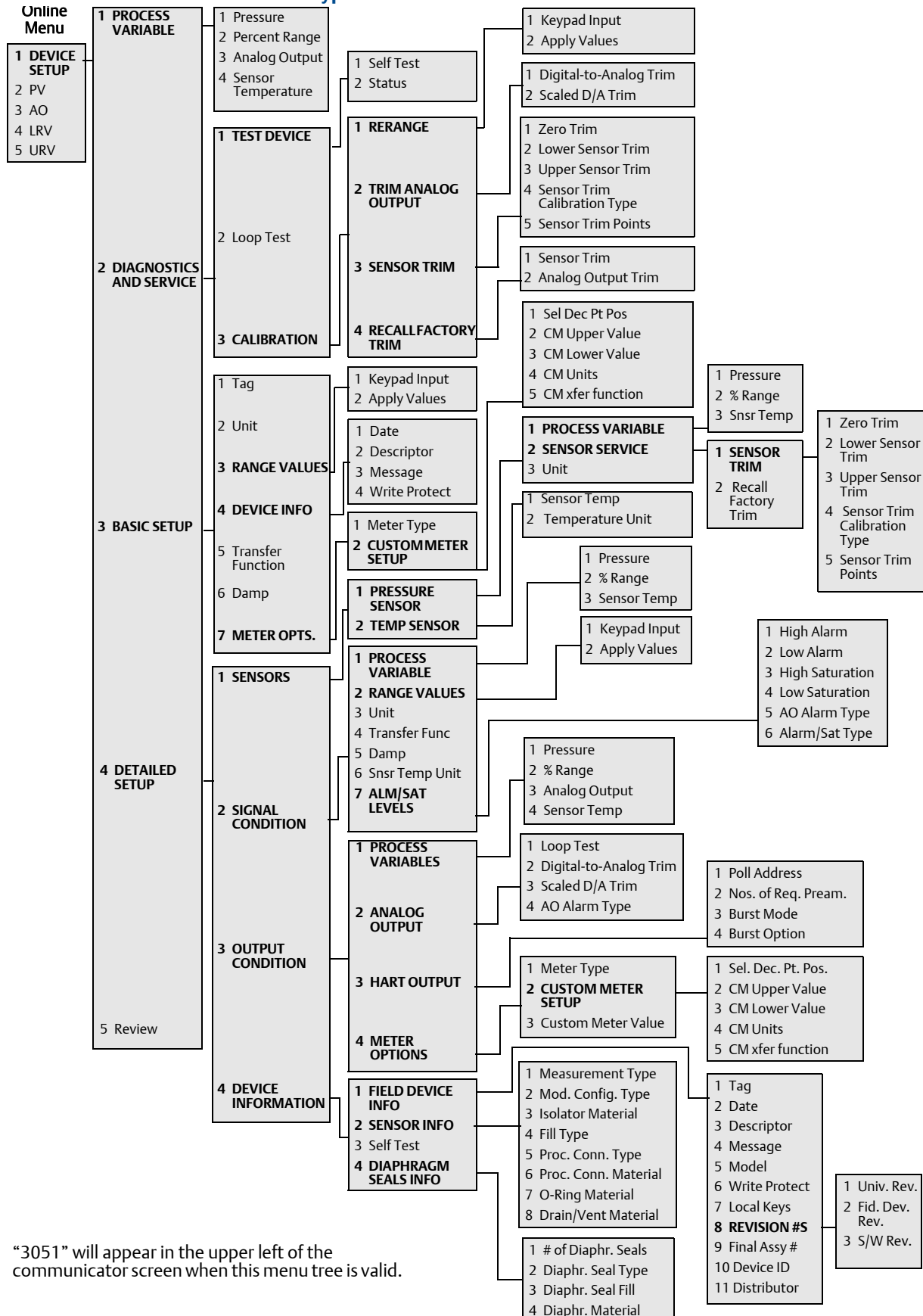

“3051” will appear in the upper left of the communicator screen when this menu tree is valid.

Table C-1. Typical HART Fast Key Sequences (partial listing)

Function	HART Fast Key sequence
Alarm and Saturation Levels	1, 4, 2, 7
Analog Output Alarm Type	1, 4, 3, 2, 4
Custom Meter Configuration	1, 3, 7, 2
Custom Meter Value	1, 4, 3, 4, 3
? Damping	1, 3, 6
Date	1, 3, 4, 1
Descriptor	1, 3, 4, 2
Digital To Analog Trim (4–20 mA Output)	1, 2, 3, 2, 1
Disable Local Span/Zero Adjustment	1, 4, 4, 1, 7
Field Device Info	1, 4, 4, 1
Full Trim	1, 2, 3, 3
Keypad Input – Rerange	1, 2, 3, 1, 1
Local Zero and Span Control	1, 4, 4, 1, 7
Loop Test	1, 2, 2
Lower Sensor Trim	1, 2, 3, 3, 2
Message	1, 3, 4, 3
Meter Options	1, 4, 3, 4
Number Of Requested Preambles	1, 4, 3, 3, 2
? Range Values	1, 3, 3
Rerange	1, 2, 3, 1
Scaled D/A Trim (4–20 mA Output)	1, 2, 3, 2, 2
Self Test (Transmitter)	1, 2, 1, 1
Sensor Info	1, 4, 4, 2
Sensor Temperature	1, 1, 4
Sensor Trim Points	1, 2, 3, 3, 5
Status	1, 2, 1, 2
? Tag	1, 3, 1
? Transfer Function (Setting Output Type)	1, 3, 5
Transmitter Security (Write Protect)	1, 3, 4, 4
Trim Analog Output	1, 2, 3, 2
? Units (Process Variable)	1, 3, 2
Upper Sensor Trim	1, 2, 3, 3, 3
Zero Trim	1, 2, 3, 3, 1

Note

A check (?) indicates the basic configuration parameters. At minimum, these parameters should be verified as part of the configuration and startup procedure.

C.3 Connections and hardware

 The HART Communicator can interface with a transmitter from the control room, the instrument site, or any wiring termination point in the loop through the communicator connections as shown in [Figure C-2](#), [Figure C-3](#), and [Figure C-4](#). To communicate, connect the HART Communicator in parallel with the instrument or load resistor. The connections are non-polarized. Before connecting the HART Communicator in an explosive atmosphere, make sure the instruments in the loop are installed in accordance with intrinsically safe or nonincendive field wiring practices.

Note

The HART Communicator needs a minimum of 250 ohms resistance in the loop to function properly. The HART Communicator is not a measurement device and does not need to be calibrated; it is a communications device through which the transmitter configuration information can read and adjusted. All variable outputs displayed by the communicator are functions of the transmitter.

Figure C-2. 275 Field Communicator Rear Connection Panel with Optional NiCad Recharger Pack

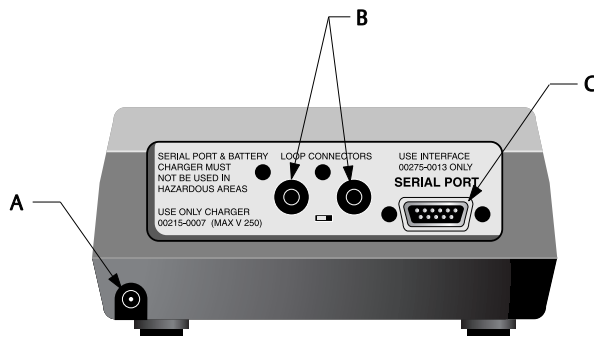

- A. NiCad recharger jack
- B. Loop connection ports
- C. Serial port

Note

Do not make connections to the serial port or NiCad recharger jack in an explosive atmosphere.

Figure C-3. 375 HART Communicator Terminal Access Door



- A. IrDA interface (for PC communication)
- B. HART Terminal Markings

 See "Safety messages" on page 60 for warning information.

Figure C-4. 475 HART Communicator Terminal Access Door

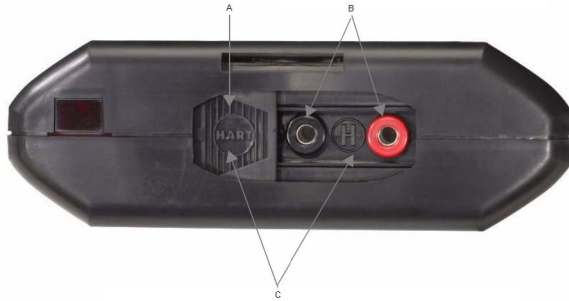

- A. Access door
- B. Communication terminals
- C. HART communication terminal markings

Figure C-5. Bench Hook-up (4–20 mA Transmitters)

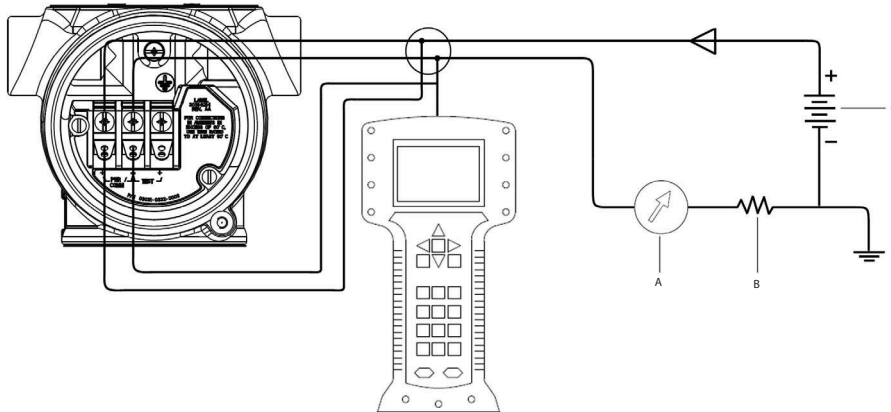

- A. Current meter
 - B. $R_L \geq 250$ ohms (necessary for HART communication only)
 - C. 24 Vdc power supply
- See "Safety messages" on page 60 for warning information.



Figure C-6. Field Hook-up (4–20 mA Transmitters)

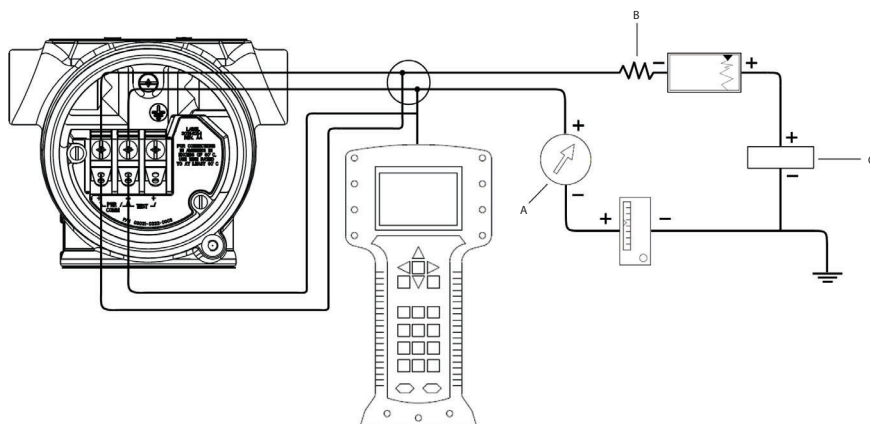

- A. Current meter
- B. $R_L \geq 250$ ohms (necessary for HART communication only)
- C. Power supply

⚠ CAUTION

Do not use inductive-based transient protectors.

Note

Signal point may be grounded at any point or left ungrounded

C.4 Menus and functions

The HART Communicator is a menu driven system. Each screen provides a menu of options that can be selected as outlined above, or provides direction for input of data, warnings, messages, or other instructions.

C.4.1 Main menu

When the HART Communicator is turned on, one of two menus will appear. If the HART Communicator is connected to an operating loop, the communicator will find the device and display the *ONLINE MENU* (see below). If not connected to a loop, the communicator will indicate that no device was found. When pressing **OK (F4)**, it will display the *MAIN* menu.

The *MAIN* menu provides the following options:

- *Offline*—provides access to offline configuration data and simulation functions
- *Online*—checks for a device and if it finds one, brings up the **ONLINE MENU**
- *Transfer*—provides access to options for transferring data either from the HART Communicator (memory) to the transmitter (device) or vice versa; transfer is used to move offline data from the HART Communicator to the transmitter, or to retrieve data from a transmitter for offline revision

Note

Online communication with the transmitter automatically loads the current transmitter data to the HART Communicator. Changes in online data are made active by pressing **SEND (F2)**. The transfer function is used only for offline data retrieval and sending.

- *Frequency Device*—displays the frequency output and corresponding pressure output of current-to-pressure transmitters (**not applicable to the Rosemount 3051N**)
- *Utility*—provides access to the contrast control for the HART Communicator LCD display screen and to the autopoll setting used in multidrop applications

Note

Although the Rosemount 3051N has multi-drop capability, which is a HART protocol feature, the Rosemount 3051N is not qualified/dedicated for use in multi-drop mode.

Once selecting a *MAIN* menu option, the HART Communicator provides the information needed to complete the operation. If further details are required, consult the HART Communicator Manual.

C.4.2 Online menu

The *ONLINE MENU* can be selected from the *MAIN* menu as outlined above, or it may appear automatically if the HART Communicator is connected to an active loop and can detect an operating transmitter.

Note

The *MAIN* menu can be accessed from the *ONLINE MENU*. Select the left arrow action key to deactivate the online communication with the transmitter and to activate the *MAIN* menu options.

When configuration variables are reset in the online mode, the new settings are not activated until the data is sent to the transmitter. Select **SEND (F2)** when it is activated to update the process variables of the transmitter.

Online mode is used for direct evaluation of a particular meter, reconfiguration, changing parameters, maintenance, and other functions.

C.4.3 Fast Key sequences

A Fast Key sequence is a sequence of numerical button presses, corresponding to the menu options leading to a given task. Instead of stepping your way through the menu structure using the action keys, you can press a HART Fast Key sequence to move from the *ONLINE MENU* to the desired variable of function. On-screen instructions provide guidance through the rest of the screens.

Example

HART Fast Key sequences are made up of the series of numbers corresponding to the individual options in each step of the menu structure. For example, the date can be changed from the *ONLINE MENU*. Following the menu structure, select **1** to reach Device Setup, select **3** for Basic Setup, select **4** for Device Info, select **1** for Date. The corresponding HART Fast Key sequence is **1, 3, 4, 1**.

HART Fast Keys are operational only from the *ONLINE MENU*. If using them consistently, return to the *ONLINE MENU* by selecting the **HOME** button when it is available. If not starting at the *ONLINE MENU*, the HART Fast Key sequences will not function properly.

Use [Table C-1](#), an alphabetical listing of most online functions, to find the corresponding HART Fast Key sequences. These codes are applicable only to Rosemount 3051N Transmitters and the HART Communicator. For additional details, refer to the applicable HART Field Communicator User Manual.

C.4.4 Hot Key options

The Hot Key menu is a user-definable menu that can store shortcuts for up to 20 frequently performed tasks. For example, if the device tags and damping are changed often, options can be added for these functions to the Hot Key menu for quick access. The 275 HART Communicator has a Hot Key button as an Action Key located on the communicator panel. For the 375 and 475 HART Communicators, once online the Hot Key will automatically appear in the toolbar. To add a custom option to the Hot Key menu, refer to the applicable HART Field Communicator User Manual.

C.5 Diagnostic messages

The following pages contain a list of messages used by the 275, 375, and 475 HART Communicators (HC) and their corresponding descriptions.

Variable parameters within the text of a message are indicated with *<variable parameter>*.

Reference to the name of another message is identified by *[another message]*.

Message	Description
1k snsr EEPROM error-factory ON	Return to Rosemount Nuclear Instruments, Inc. for repair.
1k snsr EEPROM error-user-no out ON	Use HART communicator to reset the following parameters: remote seal isolator, remote seal fill fluid, flange material, O-ring material, transmitter type, remote seal type, flange type, meter type, number of remote seals.
1k snsr EEPROM error-user ON	Perform a full trim to recalibrate the transmitter.
4k micro EEPROM error-factory ON	Return to Rosemount Nuclear Instruments, Inc. for repair.
4k micro EEPROM error-user-no out ON	Use HART communicator to reset the message field.
4k micro EEPROM error-user ON	Use HART communicator to reset the following parameters: units, range values, damping, analog output, transfer function, tag, scaled meter values. Perform a d/a trim to ensure that the error is corrected.
4k snsr EEPROM error-factory ON	Return to Rosemount Nuclear Instruments, Inc. for repair.
4k snsr EEPROM error-user ON	Use HART communicator to reset the temperature units and the calibration type.
Add item for ALL device types or only for this ONE device type.	Asks user whether the Hot Key item being added should be added for all device types or only for the type of device that is connected.
Command Not Implemented	The connected device does not support this function.
Communication Error	The communicator and device are not communicating correctly. Check all connections between the communicator and the device and resend the information.
Configuration memory not compatible with connected device	The configuration stored in memory is incompatible with the device to which a transfer has been requested.
CPU board not initialized ON	The electronics board is not initialized. Return to Rosemount Nuclear Instruments, Inc. for repair.
CPU EEPROM write failure ON	Message sent to electronics board from HART signal failed. Return to Rosemount Nuclear Instruments, Inc. for repair.
Device Busy	The connected device is busy performing another task.
Device Disconnected	The device failed to respond to a command. Check all connections between the communicator and the device and resend the command.
Device write protected	Device is in write-protect mode. Data can not be written.
Device write protected. Do you still want to shut off?	Device is in write-protect mode. Select YES to turn the HART communicator off and lose the unsent data.
Display value of variable on hotkey menu?	Asks whether the variable value should be displayed adjacent to its label on the hotkey menu if the item being added to the hotkey menu is a variable.

Message	Description
Download data from configuration memory to device	Select the SEND softkey to transfer information from the communicator memory to the device.
Exceed field width	Indicates the field width for the current arithmetic variable exceeds the device-specified description edit format.
Exceed precision	Indicates the precision for the current arithmetic variable exceeds the device-specified description edit format.
Ignore next 50 occurrences of status?	Select YES to ignore the next 50 occurrences of device status, or select NO to display every occurrence.
Illegal character	An invalid character for the variable type was entered.
Illegal date	The day portion of the date is invalid.
Illegal month	The month portion of the date is invalid.
Illegal year	The year portion of the date is invalid.
Incompatible CPU board and module ON	Return to Rosemount Nuclear Instruments, Inc. for repair.
Incomplete exponent	The exponent of a scientific notation floating point variable is incomplete.
Incomplete field	The value entered is not complete for the variable type.
Looking for a device	Polling for multidropped devices at addresses 1–15.
Local buttons operator error ON	Illegal pressure applied during zero or span operation. Repeat the process after verifying the correct pressures.
Mark as read only variable on hotkey menu?	Asks whether the user should be allowed to edit the variable from the hotkey menu if the item being added to the hotkey menu is a variable.
Module EEPROM write failure ON	Message sent to the module from the HART signal failed. Return to Rosemount Nuclear Instruments, Inc. for repair.
No device configuration in configuration memory	There is no configuration saved in memory available to re-configure offline or transfer to a device.
No Device Found	Poll of address zero fails to find a device, or poll of all addresses fails to find a device if auto-poll is enabled.
No hotkey menu available for this device.	There is no menu named “hotkey” defined in the device description for this device.
No pressure updates ON	No pressure updates being received from the sensor module. Verify the sensor module ribbon cable is attached correctly. Return to Rosemount Nuclear Instruments, Inc. for repair.
No offline devices available.	There are no device descriptions available to be used to configure a device offline.
No simulation devices available.	There are no device descriptions available to simulate a device.
No temperature updates ON	No temperature updates being received from the sensor module. Verify the sensor module ribbon cable is attached correctly. Return to Rosemount Nuclear Instruments, Inc. for repair.
No UPLOAD_VARIABLES in ddl for this device	There is no menu named “upload_variables” defined in the device description for this device. This menu is required for offline configuration.
No Valid Items	The selected menu or edit display contains no valid items.
OFF KEY DISABLED	Appears when user attempts to turn the HC off before sending modified data or before completing a method.
Online device disconnected with unsent data. RETRY or OK to lose data.	There is unsent data for a previously connected device. Select RETRY to send data, or select OK to disconnect and lose unsent data.

Message	Description
Out of memory for hotkey configuration. Delete unnecessary items.	There is no more memory available to store additional hotkey items. Unnecessary items should be deleted to make space available.
Overwrite existing configuration memory	Requests permission to overwrite existing configuration either by a device-to-memory transfer or by an offline configuration. User answers using the softkeys.
Press OK...	Select the OK softkey. This message usually appears after an error message from the application or as a result of HART communications.
Restore device value?	The edited value sent to a device was not properly implemented. Restoring the device value returns the variable to its original value.
ROM checksum error ON	Checksum of transmitter software has detected a fault. Return to Rosemount Nuclear Instruments, Inc. for repair.
Save data from device to configuration memory	Prompts user to select SAVE softkey to initiate a device-to-memory transfer.
Saving data to configuration memory.	Data is being transferred from a device to configuration memory.
Sending data to device.	Data is being transferred from configuration memory to a device.
Sensor board not initialized ON	The sensor module electronics board is not initialized. Return to Rosemount Nuclear Instruments, Inc. for repair.
There are write only variables which have not been edited. Please edit them.	There are write-only variables which have not been set by the user. These variables should be set or invalid values may be sent to the device.
There is unsent data. Send it before shutting off?	Select YES to send unsent data and turn the HC off. Select NO to turn the HC off and lose the unsent data.
Too few data bytes received	Command returns fewer data bytes than expected as determined by the device description.
Transmitter Fault	Device returns a command response indicating a fault with the connected device.
Units for <variable label> has changed. Unit must be sent before editing, or invalid data will be sent.	The engineering units for this variable have been edited. Send engineering units to the device before editing this variable.
Unsent data to online device. SEND or LOSE data	There is unsent data for a previously connected device which must be sent or thrown away before connecting to another device.
Upgrade 275 Field Communicator software to access XMTR function. Continue with old description?	The communicator does not contain the most recent Rosemount 3051N Device Descriptors (DDs). Select YES to communicate using the existing DDs. Select NO to abort communication.
Use up/down arrows to change contrast. Press DONE when done.	Gives direction to change the contrast of the HC display.
Value out of range	The user-entered value is either not within the range for the given type and size of variable or not within the min/max specified by the device.
<message> occurred reading/writing <variable label>	Either a read/write command indicates too few data bytes received, transmitter fault, invalid response code, invalid response command, invalid reply data field, or failed pre- or post-read method; or a response code of any class other than <i>SUCCESS</i> is returned reading a particular variable.
<variable label> has an unknown value. Unit must be sent before editing, or invalid data will be sent.	A variable related to this variable has been edited. Send related variable to the device before editing this variable.

This page intentionally left blank

Appendix D Glossary

Analog output trim

Digital trim operation that allows adjustment of the output electronics to conform to the plant standard. Three types of analog output trim are available: 4–20 mA Trim, 4–20 mA Other Scale, and Low Power. See “[Analog output trim](#)” on page 20. Low Power is not approved for use with the Rosemount 3051N.

Cloning

Offline operation that uses the HART® Communicator (275, 375, or 475 Field Communicator) to copy configuration data from one transmitter to one or more other transmitters that require the same data.

Commissioning

Functions performed with a HART-based communicator and the transmitter which test the transmitter, test the loop, and verify transmitter configuration data. See “[Commissioning transmitter with a HART-based communicator](#)” on page 6.

Configuration

Process of setting parameters that determine how the transmitter operates.

Damping

Output function that increases the response time of the transmitter to smooth the output when there are rapid input variations. See “[Analog output trim](#)” on page 20.

Descriptor

Sixteen-character field for additional identification of the transmitter, its use, or location. The descriptor is stored in the transmitter and can be changed using the HART-based communicator.

Digital trim

Format function that allows you to adjust the transmitter characterization for purposes of digital calibration to plant standards. Digital trim includes two separate operations: Sensor Trim and Analog Output Trim. See [Analog output trim](#) above.

Failure mode alarm

Transmitter function that drives the analog output to a jumper-selectable high or low value in the event of an electronics failure. See “[Failure mode alarm](#)” on page 4.

Factory characterization

Factory process during which each sensor module is subjected to pressures and temperatures covering the full operating range. The sensor module memory stores data generated from this process for use by the microprocessor in correcting the transmitter output during operation.

Full trim

Sensor trim function in which two accurate, end-point pressures are applied, and all output is linearized between them. The selected end points should always be equal to or outside the LRV and URV. See “[Full trim](#)” on page 19.

HART (Highway Addressable Remote Transducer) Protocol

Communications standard that provides simultaneous analog and digital signal transmission between control rooms and field devices such as transmitters. All Rosemount SMART FAMILY products communicate using the HART protocol.

Lower Range Limit (LRL)

Lowest value of the measured variable that the transmitter can be configured to measure.

Lower Range Value (LRV)

Lowest value of the measured variable that the analog output of the transmitter is currently configured to measure.

Multidropping

The connection of several transmitters to a single communications transmission line. Communication between the host and the transmitters takes place digitally with the analog output of the transmitters deactivated. **Note that although the Rosemount 3051N has multi-drop capability, which is a HART protocol feature, the Rosemount 3051N is not qualified/dedicated for use in multi-drop mode.**

Reranging

Configuration function that changes the transmitter 4 and 20 mA settings. See “Rerange” on page 10.

Send data

HART-based communicator command that transfers configuration data from the hand-held communicator’s memory to the transmitter memory.

Sensor trim

Digital trim function that allows you to adjust the digital process variable reading to a precise pressure input. Zero Trim and Full Trim are the two sensor trim functions. See “Sensor trim” on page 18.

Smart

Term used to describe instruments that are microprocessor-based and feature advanced communications capabilities. See [Section 2: Transmitter Functions](#).

SMART family

Rosemount pressure, temperature, level, and flow instruments with microprocessor-based digital electronics.

Span

Algebraic difference between the upper and lower range values.

Tag

Eight-character field for identifying the transmitter. The tag is stored in the transmitter and can be changed using the HART Communicator (275, 375, or 475 Field Communicator) and the *Transmitter Information* function.

Transmitter address

Unique number (1-15) used to identify a multidropped transmitter. Transmitters that are not multidropped have 0 as an address. Note that although the Rosemount 3051N has multi-drop capability, which is a HART Protocol feature, the Rosemount 3051N is not qualified/dedicated for use in multi-drop mode.

Transmitter security

Jumper-selectable feature that prevents accidental or deliberate changes to configuration data. See “Transmitter security” on page 4.

Upper Range Limit (URL)

Highest value of the measured variable the transmitter can be configured to measure.

Upper Range Value (URV)

Highest value of the measured variable the analog output of the transmitter is currently configured to measure.

Zero trim

A zero-based, one-point adjustment used in differential pressure applications to compensate for mounting position effects or zero shifts caused by static pressure. See “Zero trim” on page 18.

This page intentionally left blank

Revision status (changes from October 2016 to March 2021)

Page (Old)	Page (New)	Changes
Front cover, throughout	Front cover, throughout	Updated document revision from DA to EA, implementation date from October 2016 to March 2021
41	41	Specified during and post seismic accuracy for range 0 differential transmitters, added related footnote
Throughout, back cover	Throughout, back cover	Updated telephone contact information

Note

The above revision status list summarizes the changes made. Refer to both manuals for complete comparison details.

Global Headquarters

Emerson Process Management

Rosemount Nuclear Instruments, Inc.

8200 Market Blvd.

Chanhassen, MN 55317, USA

 +1 952 949-5200

 +1 952 949-5201

 RNII.info@Emerson.com

Standard Terms and Conditions of Sale can be found at:

www.Emerson.com/en-us/Terms-of-Use

The Emerson logo is a trademark and service mark of Emerson Electric Co.

Rosemount and Rosemount logotype are trademarks of Emerson.

All other marks are the property of their respective owners.

© 2021 Emerson. All rights reserved.