



Installation Operation Maintenance

RTHF

Water Cooled Liquid Chillers

with Helical Rotary Compressors

RTHF XE / HSE / XSE: 1140-3670 kW (R134a)

RTHF XE / HSE: 850-2760 kW (R1234ze)



XSTREAM

EXCELLENT

May 2020

RLC-SVX021D-GB

TRANE
TECHNOLOGIES

Confidential and proprietary Trane information
Original instructions

Contents

Introduction.....	4
Unit model number description	6
General Data	8
Table 1 – General Data RTHF Extra Efficiency (XE) - R134a	8
Table 2 – General Data RTHF High Seasonal Efficiency (HSE) - R134a..	10
Table 3 – General Data RTHF Extra High Efficiency (XSE) - R134a	13
Table 4 – General Data RTHF Extra Efficiency (XE) - R1234ze	14
Table 5 – General Data High Seasonal Efficiency (HSE) - R1234ze	16
Unit Description.....	18
Installation - Mechanical	20
Installation - Electrical	32
Operating Principles Mechanical.....	38
Typical Operating map	44
Controls/TracerTD7 Operator Interface.....	45
Pre-Start Checkout	46
Unit Start-up.....	48
Periodic Maintenance.....	49
Maintenance Procedures	52
Recommended service routine frequencies.....	57
Additional services	58





Introduction

Foreword

These instructions are given as a guide to good practice in the installation, start-up, operation, and maintenance by the user, of Trane XStream chiller RTHF manufactured in France. A separate manual is available for the use and maintenance of the unit's control, Tracer™ UC800. They do not contain full service procedures necessary for the continued successful operation of this equipment. The services of a qualified technician should be employed through the medium of a maintenance contract with a reputable service company. Read this manual thoroughly before unit start-up.

Units are assembled, pressure tested, dehydrated, charged and tested in accordance with factory standard before shipment.

Warnings and Cautions

Warnings and Cautions appear at appropriate sections throughout this manual. Your personal safety and the proper operation of this machine require that you follow them carefully. The constructor assumes no liability for installations or servicing performed by unqualified personnel.

WARNING: Indicates a potentially hazardous situation which, if not avoided, could result in death or serious injury.

CAUTION: Indicates a potentially hazardous situation which, if not avoided, may result in minor or moderate injury. It may also be used to alert against unsafe practices or for equipment or property-damage-only accidents.

Safety Recommendations

To avoid death, injury, equipment or property damage, the following recommendations should be observed during maintenance and service visits:

The maximum allowable pressures for system leak testing on low and high pressure side are given in the chapter "Installation". Ensure to do not exceed test pressure by using appropriate device.

Disconnect all power supplies before any servicing on the unit.

Service work on the refrigeration system and the electrical system should be carried out only by qualified and experienced personnel.

To avoid any risk, it is recommended to place the unit on an area with restricted access.

Reception

On arrival, inspect the unit before signing the delivery note. Specify any visible damage on the delivery note, and send a registered letter of protest to the last carrier of the goods within 7 days of delivery.

Notify the local TRANE sales office at the same time. The delivery note must be clearly signed and countersigned by the driver.

Any concealed damage shall be notified by a registered letter of protest to the last carrier of the goods within 7 days of delivery. Notify the local TRANE sales office at the same time.

Important notice: No shipping claims will be accepted by TRANE if the above mentioned procedure is not respected.

For more information, refer to the general sales conditions of your local TRANE sales office.

Note: Unit inspection in France. Delay to send registered letter in case of visible and concealed damage is only 72 hours.

Loose Parts Inventory

Check all the accessories and loose parts that are shipped with the unit against the shipping list. Included in these items will be the water vessel drain plugs, Water Flow Switch (optional), rigging and electrical diagrams, service literature, which are placed inside the control panel and/or starter panel for shipment.

If optional elastomeric isolators are ordered with the unit they are shipped mounted on the horizontal support frame of the chiller. The isolators' location and distribution weight diagram is placed with the service literature inside the starter/control panel.

Warranty

Warranty is based on the general terms and conditions of the manufacturer. The warranty is void if the equipment is repaired or modified without the written approval of the manufacturer, if the operating limits are exceeded or if the control system or the electrical wiring is modified. Damage due to misuse, lack of maintenance or failure to comply with the manufacturer's instructions or recommendations is not covered by the warranty obligation. If the user does not conform to the rules of this manual, it may entail cancellation of warranty and liabilities by the manufacturer.

Introduction

Unit Description

The RTHF unit is helical-rotary type, water-cooled, liquid chillers, designed for installation indoors. The units have 2 independent refrigerant circuits, with one or two compressors per circuit. The RTHF unit is packaged with an evaporator and condenser.

Note: Each RTHF unit is a completely assembled, hermetic package that is factory-piped, wired, leak tested, dehydrated, charged and tested for proper control operations prior to shipment. The chilled water inlet and outlet openings are covered for shipment.

The RTHF series features Trane's exclusive Adaptive Control logic with UC800 controls. It monitors the control variables that govern the operation of the chiller unit. Adaptive Control logic can correct these variables, when necessary, to optimize operational efficiencies, avoid chiller shutdown, and keep producing chilled water.

Compressor loading/unloading is provided by:

Slide valve solenoid activated or AFD (Adaptive Frequency Drive) coordinated with slide valve operation

Each refrigerant circuit is provided with filter, sight glass, electronic expansion valve, and charging valves on the RTHF.

The evaporator and condenser are manufactured in accordance with Pressure Equipment Directive standards. The evaporator is insulated according the option ordered. Both evaporator and condenser are equipped with water drain and vent connections.

Refrigerant

Consult the addendum to Manuals for units with refrigerant, for conformity to the Pressure Equipment Directive (PED) 97/23/EC and Machinery Directive 2006/42/EC and for specific caution for R1234ze.

Maintenance contract

It is strongly recommended that you sign a maintenance contract with your local Trane Service Agency. This contract provides regular maintenance of your installation by a specialist in our equipment. Regular maintenance ensures that any malfunction is detected and corrected in good time and minimizes the possibility that serious damage will occur. Finally, regular maintenance ensures the maximum operating life of your equipment. We would remind you that failure to respect these installation and maintenance instructions may result in immediate cancellation of the warranty.

Training

To assist you in obtaining the best use of it and maintaining it in perfect operating condition over a long period of time, the manufacturer has at your disposal a refrigeration and air conditioning service school. The principal aim of this is to give operators and technicians a better knowledge of the equipment they are using, or that is under their charge. Emphasis is particularly given to the importance of periodic checks on the unit operating parameters as well as on preventive maintenance, which reduces the cost of owning the unit by avoiding serious and costly breakdown.



Unit model number description

Digit 1, 2, 3, 4 – Unit Model

RTHF

Digit 5, 6, 7 – Unit size

250 = 250 Tons
270 = 270 Tons
295 = 295 Tons
305 = 305 Tons
320 = 320 Tons
330 = 330 Tons
335 = 335 Tons
355 = 355 Tons
360 = 360 Tons
370 = 370 Tons
400 = 400 Tons
405 = 405 Tons
410 = 410 Tons
440 = 440 Tons
445 = 445 Tons
460 = 460 Tons
480 = 480 Tons
490 = 490 Tons
500 = 500 Tons
520 = 520 Tons
535 = 535 Tons
540 = 540 Tons
560 = 560 Tons
590 = 590 Tons
595 = 595 Tons
600 = 600 Tons
630 = 630 Tons
640 = 640 Tons
650 = 650 Tons
680 = 680 Tons
700 = 700 Tons
720 = 720 Tons
750 = 750 Tons
780 = 780 Tons
800 = 800 Tons
840 = 840 Tons
850 = 850 Tons
855 = 855 Tons
900 = 900 Tons
905 = 905 Tons
945 = 945 Tons
950 = 950 Tons
995 = 995 Tons
K00 = 1000 Tons

Digit 8 – Unit Power supply

D = 400 V – 50 Hz – 3Ph

Digit 9 – Factory

E = Europe

Digit 10&11 – Design Sequence

XX = Factory assigned

Digit 12 – Efficiency Level

A = Extra Efficiency (XE)

Digit 13 – Starter type

Y = Star-Delta closed transition starter
B = VFD (Variable Frequency Drive)

Digit 14 – Agency listing

C = CE marking

Digit 15 – Pressure Vessel Code

2 = PED (Pressure Equipment Directive)

Digit 16 – Unit Application

X = Standard Condenser Temperature
H = Water to Water Heat Pump

Digit 17 – Refrigerant

1 = R134a unit with Factory charge (with oil)
0 = R134a with pre-charge (with oil)
N = R134a unit with Nitrogen (no oil)
Z = R1234ze unit with Factory charge (with oil)
Y = R1234ze with pre-charge (with oil)
L = R1234ze unit with Nitrogen (no oil)

Digit 18 – Open for future use

XX = **

Digit 19 – Relief Valve Option

L = Single Relief Valve Condenser
2 = Single Relief Valve Condenser & Evaporator
D = Dual relief valve with 3 way valve condenser
4 = Dual relief valve with 3 way valve condenser & Evaporator

Digit 20 – Compressor Type

X = CHHC
V = CHHC Var Vi

Digit 21 & 22 – Evaporator size

2A = Evaporator E516A
2B = Evaporator E516B
2C = Evaporator E516C
2D = Evaporator E516D
2E = Evaporator E516E
3A = Evaporator E580A
3B = Evaporator E580B
3C = Evaporator E580C
4A = Evaporator E800A
4B = Evaporator E800B
4C = Evaporator E800C
4D = Evaporator E800D

Digit 23 – Evaporator Configuration

X = Standard Single Pass
T = Single Pass Evaporator with turbulators

Digit 24 – Evaporator Water connection

X = Standard Grooved Pipe connection
L = LH Evap Grooved pipe
R = RH Evap Grooved pipe

Digit 25 – Evaporator Water side Pressure

X = 10 Bar Evaporator Water Pressure

Digit 26 – Evaporator application

N = Comfort Cooling (above 4.4°C)
P = Process Cooling (0°C, 4.4°C)
L = Process Cooling below 0°C
C = Ice Making (-7°C, 20°C)

Digit 27 – Cold Parts Thermal insulation

N = Standard
X = None

Digit 28 & 29 – Condenser size

4A = Condenser C501A
4B = Condenser C501B
4C = Condenser C501C
4D = Condenser C501D
4E = Condenser C501E
5A = Condenser C550A
5B = Condenser C550B
5C = Condenser C550C
6A = Condenser C800A
6B = Condenser C800B
6C = Condenser C800C

Digit 30 – Condenser Configuration

X = Standard Single pass
2 = 2 passes

Unit model number description

Digit 31 – Condenser Water connection

X = Standard Grooved Pipe connection
L = Left Hand Grooved pipe
R = Right Hand Grooved pipe

Digit 32 – Condenser Tubes

N = Enhanced Fin – Copper

Digit 33 – Condenser Water side pressure

X = 10 Bar Condenser Water Pressure

Digit 34 – Condenser Thermal Insulation

X = Without Condenser Insulation
H = With Condenser Insulation

Digit 35 – Oil cooler

X = Without
C = With

Digit 36 – Evaporator Pump Smart Flow control

X = None
E = VPF Constant DeltaT Evaporator

Digit 37 – Power Protection

F = With fuses
B = With circuit breakers
D = Dual Power Supply with circuit breakers

Digit 38 – Under/Over voltage protection

X = None
1 = Included
2 = Included with ground fault protection

Digit 39 – Human interface language

C = Spanish
D = German
E = English
F = French
H = Dutch
I = Italian
M = Swedish
P = Polish
R = Russian
T = Czech
U = Greek
V = Portuguese
2 = Romanian
6 = Hungarian
8 = Turkish

Digit 40 – Smart com protocole

X = None
B = BACnet MSTP interface
C = BACnet IP interface
M = Modbus RTU interface
L = LonTalk interface

Digit 41 – Communication customer input/output

X = None
A = External Set points & Capacity outputs – Voltage Signal
B = External Set points & Capacity outputs – Current Signal

Digit 42 – Outdoor Air Temperature Sensor

0 = No Air Outdoor Temperature Sensor
A = Outdoor Air Temperature Sensor – CWR/Low Ambient

Digit 43 – Electrical IP protection

X = Enclosure with dead front protection
1 = Enclosure with IP20 internal protection

Digit 44 – Master Slave Set

X = None
M = With Master/Slave control
Unit model number description

Digit 45 – Energy meter

X = Without
M = Included

Digit 46 – Condenser Pump Smart Flow Control/Other Condenser Pressure Control Outputs

X = None
1 = Condenser Pressure in % HPC
2 = Differential Pressure
3 = Condenser Head Pressure Flow Control
4 = VPF Constant DeltaT Condenser Flow Control

Digit 47 – Power socket

X = None
P = Included (230V-100W)

Digit 48 – Factory test

X = None
B = Visual inspection with Customer attendance
E = 1 point Test with Report

Digit 49 – Installation Accessory

X = Without
1 = Neoprene isolators
4 = Neoprene pads

Digit 50 – Connection Accessory

X = Grooved pipe connection
W = Grooved pipe with coupling and pipe stub

Digit 51 – Flow switch

X = None
A = Evaporator or Condenser
B = Evaporator and Condenser

Digit 52 – Literature Language

C = Spanish
D = German
E = English
F = French
H = Dutch
I = Italian
M = Swedish
P = Polish
R = Russian
T = Czech
V = Portuguese
2 = Romanian
6 = Hungarian
8 = Turkish

Digit 53 – Shipping package

X = Standard Protection
A = Containerization Package

Digit 54 – EXV selection

L = Standard EXV
U = Undersized EXV

Digit 55 – AFD Selection

X = Max RLA
V = Limited RLA

Digit 56 – Design special

X = None
S = Special

General Data

Table 1 – General Data RTHF Extra Efficiency (XE) - R134a

		RTHF 330 XE	RTHF 360 XE	RTHF 410 XE	RTHF 460 XE	RTHF 500 XE	RTHF 540 XE
Indicative performances (1)							
Gross Cooling Capacity (1)	(kW)	1141	1258	1459	1573	1777	1898
Gross Total Power input in cooling (1)	(kW)	190	212	247	267	301	318
Unit Electrical data (2) (5)							
Maximum Power Input	(kW)	291	291	355	355	419	419
Unit rated amps (2)	(A)	468	466	583	582	698	698
Unit start up amps (2)	(A)	647	645	762	761	829	829
Displacement power factor	#	0.9	0.9	0.88	0.88	0.87	0.87
Short Circuit Unit Capacity	(kA)	35	35	35	35	35	35
Max Power cable (cross)	(mm ²)	2*300	2*300	2*300	2*300	2*300	2*300
Disconnect switch size (3)	(A)	800	800	800	800	800	800
Compressor							
Compressor Number per Circuit	#	1	1	1	1	1	1
Type	#	Screw	Screw	Screw	Screw	Screw	Screw
Model	#	B1/B1	B2/B2	C1/B2	C2/B2	C2/C1	C2/C2
Max compr Power input Circuit 1 / Circuit 2	(kW)	145/145	145/145	209/145	209/145	209/209	209/209
Max Amps Circuit 1 / Circuit 2	(A)	233/233	233/233	349/233	349/233	349/349	349/349
Motor max RPM (variable speed)	(RPM)	3000	3000	3000	3000	3000	3000
Oil sump heater Circuit 1 / Circuit 2	(kW)	0.3/0.3	0.3/0.3	0.3/0.3	0.3/0.3	0.3/0.3	0.3/0.3
Evaporator							
Quantity	#	1	1	1	1	1	1
Type	#	Flooded shell and tube heat exchanger					
Evaporator model	#	516D	516C	580B	580B	580A	580A
Evaporator Content volume	(l)	148	160	187	187	211	211
One pass evaporator							
Evap. Water Flow rate - Minimum (4)	(l/s)	25.2	28	34	34	39.4	39.4
Evap. Water Flow rate - Maximum (4)	(l/s)	93	103.2	124.8	124.8	144.6	144.6
Nominal water connection size (Grooved coupling)	(in)	8	8	8	8	8	8
One pass with turbulator evaporator							
Evap. Water Flow rate - Minimum (4)	(l/s)	21	23.3	28.3	28.3	32.8	32.8
Evap. Water Flow rate - Maximum (4)	(l/s)	84.5	93.8	113.5	113.5	131.5	131.5
Nominal water connection size (Grooved coupling)	(in)	8	8	8	8	8	8
Condenser							
Quantity	#	1	1	1	1	1	1
Type	#	Shell and tube heat exchanger					
Condenser model	#	501B	501A	550B	550B	550B	550A
Condenser Water Content Volume	(l)	287	304	350	350	350	369
One pass condenser							
Cond. Water Flow rate - Minimum	(l/s)	46.9	50.3	53.3	53.3	53.3	56.7
Cond. Water Flow rate -Maximum	(l/s)	171.9	184.2	195.3	195.3	195.3	207.7
Nominal water connection size (Grooved coupling)	(in)	8	8	8	8	8	8
Dimensions							
Unit Length	(mm)	4586	4586	4586	4586	4586	4586
Unit Width	(mm)	1840	1840	1840	1840	1840	1840
Unit Height	(mm)	2395	2395	2395	2395	2395	2395
Weights							
Shipping Weight	(kg)	6920	7000	8080	8080	9100	9130
Operating Weight	(kg)	7350	7450	8590	8590	9630	9680
System data (5)							
Nb of refrigerant circuit	#	2	2	2	2	2	2
Minimum cooling capacity per circuit %	%	30	30	30	30	30	30
Standard unit							
Refrigerant charge Circuit 1 / Circuit 2 (5)	(kg)	176/174	180/180	181/181	178/180	197/202	197/199
Oil charge Circuit 1 / Circuit 2 (5)	(l)	16/16	16/16	24/16	24/16	24/24	24/24
POE Oil type	#	OIL0023E/48E					

(1) Indicative performance at Evaporator water temperature: 12°C / 7°C - Condenser water temperature 30 / 35°C - for detailed performances consult order write up.

(2) Under 400V/3/50Hz.

(3) Option fuse + disconnect switch.

(4) Not applicable for Glycol application - see tables with Minimum Flow with Glycol.

(5) Electrical & system data are indicative and subject to change without notice. Please refer to unit nameplate data.

General Data

Table 1 – RTHF General Data Extra Efficiency (XE) - R134a (Continued)

		RTHF 600 XE	RTHF 650 XE	RTHF 700 XE	RTHF 750 XE	RTHF 800 XE	RTHF 840 XE
Indicative performances (1)							
Gross Cooling Capacity (1)	(kW)	2110	2250	2510	2645	2826	3009
Gross Total Power input in cooling (1)	(kW)	333	365	397	427	466	504
Unit Electrical data (2) (5)							
Maximum Power Input	(kW)	490	561	561	561	582	603
Unit rated amps (2)	(A)	804	910	910	910	943	976
Unit start up amps (2)	(A)	1097	1203	1203	1203	1236	1236
Displacement power factor	#	0.88	0.89	0.89	0.89	0.89	0.89
Short Circuit Unit Capacity	(kA)	35	35	35	35	35	35
Max Power cable (cross)	(mm ²)	4*185	4*185	4*185	4*185	4*185	4*185
Disconnect switch size (3)	(A)	1250	1250	1250	1250	1250	1250
Compressor							
Compressor Number per Circuit	#	1	1	1	1	1	1
Type	#	Screw	Screw	Screw	Screw	Screw	Screw
Model	#	D1/C2	D1/D1	D2/D2	D3/D3	E3/D3	E3/E3
Max compr Power input Circuit 1 / Circuit 2	(kW)	280/209	280/280	280/280	280/280	301/280	301/301
Max Amps Circuit 1 / Circuit 2	(A)	455/349	455/455	455/455	455/455	488/455	488/488
Motor max RPM (variable speed)	(RPM)	3000	3000	3000	3000	3000	3000
Oil sump heater Circuit 1 / Circuit 2	(kW)	0.3/0.3	0.3/0.3	0.3/0.3	0.3/0.3	0.3/0.3	0.3/0.3
Evaporator							
Quantity	#	1	1	1	1	1	1
Type	#	Flooded shell and tube heat exchanger					
Evaporator model	#	800A	800A	800A	800A	800A	800A
Evaporator Content volume	(l)	324	324	324	324	324	324
One pass evaporator							
Evap. Water Flow rate - Minimum (4)	(l/s)	63.8	63.8	63.8	63.8	63.8	63.8
Evap. Water Flow rate - Maximum (4)	(l/s)	234	234	234	234	234	234
Nominal water connection size (Grooved coupling)	(in)	10	10	10	10	10	10
One pass with turbulator evaporator							
Evap. Water Flow rate - Minimum (4)	(l/s)	53.2	53.2	53.2	53.2	53.2	53.2
Evap. Water Flow rate - Maximum (4)	(l/s)	212.7	212.7	212.7	212.7	212.7	212.7
Nominal water connection size (Grooved coupling)	(in)	10	10	10	10	10	10
Condenser							
Quantity	#	1	1	1	1	1	1
Type	#	Shell and tube heat exchanger					
Condenser model	#	800A	800A	800A	800A	800A	800A
Condenser Water Content Volume	(l)	452	452	452	452	452	452
One pass condenser							
Cond. Water Flow rate - Minimum	(l/s)	90.87	90.87	90.87	90.87	90.87	90.87
Cond. Water Flow rate -Maximum	(l/s)	333.2	333.2	333.2	333.2	333.2	333.2
Nominal water connection size (Grooved coupling)	(in)	10	10	10	10	10	10
Dimensions							
Unit Length	(mm)	5521	5521	5521	5521	5521	5521
Unit Width	(mm)	2088	2088	2088	2088	2088	2088
Unit Height	(mm)	2457	2457	2457	2457	2457	2457
Weights							
Shipping Weight	(kg)	12285	12585	12585	12585	12695	12815
Operating Weight	(kg)	13080	13380	13380	13380	13490	13610
System data (5)							
Nb of refrigerant circuit	#	2	2	2	2	2	2
Minimum cooling capacity per circuit %	%	30	30	30	30	30	30
Standard unit							
Refrigerant charge Circuit 1 / Circuit 2 (5)	(kg)	283/296	283/282	280/279	280/279	275/279	275/274
Oil charge Circuit 1 / Circuit 2 (5)	(l)	30/30	30/30	30/30	30/30	30/30	30/30
POE Oil type	#	OIL0023E/48E					

(1) Indicative performance at Evaporator water temperature: 12°C / 7°C - Condenser water temperature 30 / 35°C - for detailed performances consult order write up.

(2) Under 400V/3/50Hz.

(3) Option fuse + disconnect switch.

(4) Not applicable for Glycol application - see tables with Minimum Flow with Glycol.

(5) Electrical & system data are indicative and subject to change without notice. Please refer to unit nameplate data.

General Data

Table 2 – General Data RTHF High Seasonal Efficiency (HSE) - R134a

		RTHF 330 HSE	RTHF 360 HSE	RTHF 410 HSE	RTHF 460 HSE	RTHF 500 HSE	RTHF 540 HSE	RTHF 590 HSE	RTHF 640 HSE
Indicative performances (1)									
Gross Cooling Capacity (1)	(kW)	1139	1257	1457	1570	1771	1892	2084	2272
Gross Total Power input in cooling (1)	(kW)	195	217	252	272	306	324	367	411
Unit Electrical data (2) (5)									
Maximum Power Input	(kW)	282	282	347	347	413	413	466	509
Unit rated amps (2)	(A)	429	428	527	527	627	627	708	773
Unit start up amps (2)	(A)	429	428	527	527	627	627	708	773
Displacement power factor	#	0.95	0.95	0.95	0.95	0.95	0.95	0.95	0.95
Short Circuit Unit Capacity	(kA)	35	35	35	35	35	35	35	35
Max Power cable (cross)	(mm ²)	2*300	2*300	2*300	2*300	2*300	2*300	2*300	2*300
Disconnect switch size (3)	(A)	800	800	800	800	800	800	1250	1250
Compressor									
Compressor Number per Circuit	#	1	1	1	1	1	1	1	1
Type	#	Screw	Screw	Screw	Screw	Screw	Screw	Screw	Screw
Model	#	B1/B1	B2/B2	C1/B2	C2/B2	C2/C1	C2/C2	C2/C2	C2/C2
Max compr Power input Circuit 1 / Circuit 2	(kW)	141/141	141/141	206/141	206/141	206/206	206/206	233/233	254/254
Max Amps Circuit 1 / Circuit 2	(A)	214/214	214/214	313/214	313/214	313/313	313/313	354/354	386/386
Motor max RPM (variable speed)	(RPM)	3000	3000	3000	3000	3000	3000	3300	3600
Oil sump heater Circuit 1 / Circuit 2	(kW)	0.3/0.3	0.3/0.3	0.3/0.3	0.3/0.3	0.3/0.3	0.3/0.3	0.3/0.3	0.3/0.3
Evaporator									
Quantity	#	1	1	1	1	1	1	1	1
Type	#	Flooded shell and tube heat exchanger							
Evaporator model	#	515D	515C	580B	580B	580A	580A	580A	580A
Evaporator Content volume	(l)	148	160	187	187	211	211	211	211
One pass evaporator									
Evap. Water Flow rate - Minimum (4)	(l/s)	25.2	28	34	34	39.4	39.4	39.4	39.4
Evap. Water Flow rate - Maximum (4)	(l/s)	93	103.2	124.8	124.8	144.6	144.6	144.6	144.6
Nominal water connection size (Grooved coupling)	(in)	8	8	8	8	8	8	8	8
One pass with turbulator evaporator									
Evap. Water Flow rate - Minimum (4)	(l/s)	21	23.3	28.3	28.3	32.8	32.8	32.8	32.8
Evap. Water Flow rate - Maximum (4)	(l/s)	84.5	93.8	113.5	113.5	131.5	131.5	131.5	131.5
Nominal water connection size (Grooved coupling)	(in)	8	8	8	8	8	8	8	8
Condenser									
Quantity	#	1	1	1	1	1	1	1	1
Type	#	Shell and tube heat exchanger							
Condenser model	#	500B	500A	550B	550B	550B	550A	550A	550A
Condenser Water Content Volume	(l)	287	304	350	350	350	369	369	369
One pass condenser									
Cond. Water Flow rate - Minimum	(l/s)	46.9	46.9	53.5	53.5	53.5	56.7	56.7	56.7
Cond. Water Flow rate -Maximum	(l/s)	171.9	171.9	195.3	195.3	195.3	207.7	207.7	207.7
Nominal water connection size (Grooved coupling)	(in)	8	8	8	8	8	8	8	8
Dimensions									
Unit Length	(mm)	4586	4586	4586	4586	4586	4586	4586	4586
Unit Width	(mm)	1940	1940	1940	1940	1940	1940	1940	1940
Unit Height	(mm)	2395	2395	2395	2395	2395	2395	2395	2395
Weights									
Shipping Weight	(kg)	7090	7170	8310	8310	9390	9420	9420	9420
Operating Weight	(kg)	7520	7620	8820	8820	9920	9970	9970	9970
System data (5)									
Nb of refrigerant circuit	#	2	2	2	2	2	2	2	2
Minimum cooling capacity per circuit %	%	30	30	30	30	30	30	30	30
Standard unit									
Refrigerant charge Circuit 1 / Circuit 2 (5)	(kg)	176/174	180/180	181/181	178/180	197/202	197/199	196/197	194/196
Oil charge Circuit 1 / Circuit 2 (5)	(l)	16/16	16/16	24/16	24/16	24/24	24/24	24/24	24/24
POE Oil type	#	OIL00315/317							

(1) Indicative performance at Evaporator water temperature: 12°C / 7°C - Condenser water temperature 30 / 35°C - for detailed performances consult order write up.

(2) Under 400V/3/50Hz.

(3) Option fuse + disconnect switch.

(4) Not applicable for Glycol application - see tables with Minimum Flow with Glycol.

(5) Electrical & system data are indicative and subject to change without notice. Please refer to unit nameplate data.

General Data

Table 2 – General Data RTHF High Seasonal Efficiency (HSE) - R134a(Continued)

		RTHF 600 HSE	RTHF 650 HSE	RTHF 700 HSE	RTHF 750 HSE	RTHF 800 HSE	RTHF 840 HSE	RTHF 850 HSE	RTHF 900 HSE
Indicative performances (1)									
Gross Cooling Capacity (1)	(kW)	2105	2240	2500	2636	2816	2996	2996	3221
Gross Total Power input in cooling (1)	(kW)	339	372	404	434	473	522	514	584
Unit Electrical data (2) (5)									
Maximum Power Input	(kW)	478	543	543	545	566	587	715	715
Unit rated amps (2)	(A)	726	825	825	827	859	892	1086	1086
Unit start up amps (2)	(A)	726	825	825	827	859	892	1086	1086
Displacement power factor	#	0.95	0.95	0.95	0.95	0.95	0.95	0.95	0.95
Short Circuit Unit Capacity	(kA)	35	35	35	35	35	35	35	35
Max Power cable (cross)	(mm ²)	4*185	4*185	4*185	4*185	4*185	4*185	4*185	4*185
Disconnect switch size (3)	(A)	1250	1250	1250	1250	1250	1250	1250	1250
Compressor									
Compressor Number per Circuit	#	1	1	1	1	1	1	1	1
Type	#	Screw	Screw	Screw	Screw	Screw	Screw	Screw	Screw
Model	#	D1/C2	D1/D1	D2/D2	D3/D3	E3/D3	E3/E3	E3/E3	E3/E3
Max compr Power input Circuit 1 / Circuit 2	(kW)	271/206	271/271	271/271	272/272	293/272	293/293	357/357	357/357
Max Amps Circuit 1 / Circuit 2	(A)	412/313	412/412	412/412	413/413	446/413	446/446	543/543	543/543
Motor max RPM (variable speed)	(RPM)	3000	3000	3000	3000	3000	3000	3000	3000
Oil sump heater Circuit 1 / Circuit 2	(kW)	0.3/0.3	0.3/0.3	0.3/0.3	0.3/0.3	0.3/0.3	0.3/0.3	0.3/0.3	0.3/0.3
Evaporator									
Quantity	#	1	1	1	1	1	1	1	1
Type	#	Flooded shell and tube heat exchanger							
Evaporator model	#	800A	800A	800A	800A	800A	800A	800A	800A
Evaporator Content volume	(l)	324	324	324	324	324	324	324	324
One pass evaporator									
Evap. Water Flow rate - Minimum (4)	(l/s)	63.8	63.8	63.8	63.8	63.8	63.8	63.8	63.8
Evap. Water Flow rate - Maximum (4)	(l/s)	234	234	234	234	234	234	234	234
Nominal water connection size (Grooved coupling)	(in)	10	10	10	10	10	10	10	10
One pass with turbulator evaporator									
Evap. Water Flow rate - Minimum (4)	(l/s)	53.2	53.2	53.2	53.2	53.2	53.2	53.2	53.2
Evap. Water Flow rate - Maximum (4)	(l/s)	212.7	212.7	212.7	212.7	212.7	212.7	212.7	212.7
Nominal water connection size (Grooved coupling)	(in)	10	10	10	10	10	10	10	10
Condenser									
Quantity	#	1	1	1	1	1	1	1	1
Type	#	Shell and tube heat exchanger							
Condenser model	#	800A	800A	800A	800A	800A	800A	800A	800A
Condenser Water Content Volume	(l)	452	452	452	452	452	452	452	452
One pass condenser									
Cond. Water Flow rate - Minimum	(l/s)	90.87	90.87	90.87	90.87	90.87	90.87	90.87	90.87
Cond. Water Flow rate -Maximum	(l/s)	333.2	333.2	333.2	333.2	333.2	333.2	333.2	333.2
Nominal water connection size (Grooved coupling)	(in)	10	10	10	10	10	10	10	10
Dimensions									
Unit Length	(mm)	5521	5521	5521	5521	5521	5521	5521	5521
Unit Width	(mm)	2088	2088	2088	2088	2088	2088	2088	2088
Unit Height	(mm)	2457	2457	2457	2457	2457	2457	2457	2457
Weights									
Shipping Weight	(kg)	12645	12945	12945	12945	13055	13175	13775	13775
Operating Weight	(kg)	13440	13740	13740	13740	13850	13970	14570	14570
System data (5)									
Nb of refrigerant circuit	#	2	2	2	2	2	2	2	2
Minimum cooling capacity per circuit %	%	30	30	30	30	30	30	30	30
Standard unit									
Refrigerant charge Circuit 1 / Circuit 2 (5)	(kg)	283/296	283/282	280/279	280/279	275/279	275/274	275/274	275/274
Oil charge Circuit 1 / Circuit 2 (5)	(l)	30/30	30/30	30/30	30/30	30/30	30/30	30/30	30/30
POE Oil type	#	OIL00315/317							

(1) Indicative performance at Evaporator water temperature: 12°C / 7°C - Condenser water temperature 30 / 35°C - for detailed performances consult order write up.

(2) Under 400V/3/50Hz.

(3) Option fuse + disconnect switch.

(4) Not applicable for Glycol application.

(5) Electrical & system data are indicative and subject to change without notice. Please refer to unit nameplate data.

General Data

Table 2 – General Data RTHF High Seasonal Efficiency (HSE) - R134a(Continued)

		RTHF 950 HSE	RTHF 1000 HSE
Indicative performances (1)			
Gross Cooling Capacity (1)	(kW)	3446	3672
Gross Total Power input in cooling (1)	(kW)	654	729
Unit Electrical data (2) (5)			
Maximum Power Input	(kW)	715	715
Unit rated amps (2)	(A)	1086	1086
Unit start up amps (2)	(A)	1086	1086
Displacement power factor	#	0.95	0.95
Short Circuit Unit Capacity	(kA)	35	35
Max Power cable (cross)	(mm ²)	4*185	4*185
Disconnect switch size (3)	(A)	1250	1250
Compressor			
Compressor Number per Circuit	#	1	1
Type	#	Screw	Screw
Model	#	E3/E3	E3/E3
Max compr Power input Circuit 1 / Circuit 2	(kW)	357/357	357/357
Max Amps Circuit 1 / Circuit 2	(A)	543/543	543/543
Motor max RPM (variable speed)	(RPM)	3600	3900
Oil sump heater Circuit 1 / Circuit 2	(kW)	0.3/0.3	0.3/0.3
Evaporator			
Quantity	#	1	1
Type	#		
Evaporator model	#	800A	800A
Evaporator Content volume	(l)	324	324
One pass evaporator			
Evap. Water Flow rate - Minimum (4)	(l/s)	63.8	63.8
Evap. Water Flow rate - Maximum (4)	(l/s)	234	234
Nominal water connection size (Grooved coupling)	(in)	10	10
One pass with turbulator evaporator			
Evap. Water Flow rate - Minimum (4)	(l/s)	53.2	53.2
Evap. Water Flow rate - Maximum (4)	(l/s)	212.7	212.7
Nominal water connection size (Grooved coupling)	(in)	10	10
Condenser			
Quantity	#	1	1
Type	#		
Condenser model	#	800A	800A
Condenser Water Content Volume	(l)	452	452
One pass condenser			
Cond. Water Flow rate - Minimum	(l/s)	90.87	90.87
Cond. Water Flow rate -Maximum	(l/s)	333.2	333.2
Nominal water connection size (Grooved coupling)	(in)	10	10
Dimensions			
Unit Length	(mm)	5521	5521
Unit Width	(mm)	2088	2088
Unit Height	(mm)	2457	2457
Weights			
Shipping Weight	(kg)	13775	13775
Operating Weight	(kg)	14570	14570
System data (5)			
Nb of refrigerant circuit	#	2	2
Minimum cooling capacity per circuit %	%	30	30
Standard unit			
Refrigerant charge Circuit 1 / Circuit 2 (5)	(kg)	275/274	275/274
Oil charge Circuit 1 / Circuit 2 (5)	(l)	30/30	30/30
POE Oil type	#	OIL00315/317	

(1) Indicative performance at Evaporator water temperature: 12°C / 7°C - Condenser water temperature 30 / 35°C - for detailed performances consult order write up.

(2) Under 400V/3/50Hz.

(3) Option fuse + disconnect switch.

(4) Not applicable for Glycol application - see tables with Minimum Flow with Glycol.

(5) Electrical & system data are indicative and subject to change without notice. Please refer to unit nameplate data.

General Data

Table 3 – General Data RTHF Extra High Efficiency (XSE) - R134a

		RTHF 855 XSE	RTHF 905 XSE	RTHF 945 XSE	RTHF 995 XSE
Indicative performances (1)					
Gross Cooling Capacity (1)	(kW)	2973	3189	3407	3634
Gross Total Power input in cooling (1)	(kW)	519	585	649	729
Unit Electrical data (2) (5)					
Maximum Power Input	(kW)	711	713	715	715
Unit rated amps (2)	(A)	1080	1083	1086	1086
Unit start up amps (2)	(A)	1080	1083	1086	1086
Displacement power factor	#	0.95	0.95	0.95	0.95
Short Circuit Unit Capacity	(kA)	35	35	35	35
Max Power cable (cross)	(mm ²)	6 x 185	6 x 185	6 x 185	6 x 185
Disconnect switch size (3)	(A)	1600	1600	1600	1600
Compressor					
Compressor Number per Circuit	#	1	1	1	1
Type	#	Screw	Screw	Screw	Screw
Model	#	D4/D4	E4/D4	E4/E4	E4/E4
Max compr Power input Circuit 1 / Circuit 2	(kW)	355/355	357/355	357/357	357/357
Max Amps Circuit 1 / Circuit 2	(A)	540/540	543/540	543/543	543/543
Motor max RPM (variable speed)	(RPM)	3600	3600	3600	3900
Oil sump heater Circuit 1 / Circuit 2	(kW)	0.3	0.3	0.3	0.3
Evaporator					
Quantity	#	1	1	1	1
Type	#	Flooded shell and tube heat exchanger			
Evaporator model	#	800A	800A	800A	800A
Evaporator Content volume	(l)	324	324	324	324
One pass evaporator					
Evap. Water Flow rate - Minimum (4)	(l/s)	63.8	63.8	63.8	63.8
Evap. Water Flow rate - Maximum (4)	(l/s)	234	234	234	234
Nominal water connection size (Grooved coupling)	(in)	10	10	10	10
One pass with turbulator evaporator					
Evap. Water Flow rate - Minimum (4)	(l/s)	53.2	53.2	53.2	53.2
Evap. Water Flow rate - Maximum (4)	(l/s)	212.7	212.7	212.7	212.7
Nominal water connection size (Grooved coupling)	(in)	10	10	10	10
Condenser					
Quantity	#	1	1	1	1
Type	#	Shell and tube heat exchanger			
Condenser model	#	800A	800A	800A	800A
Condenser Water Content Volume	(l)	452	452	452	452
One pass condenser					
Cond. Water Flow rate - Minimum	(l/s)	90.87	90.87	90.87	90.87
Cond. Water Flow rate -Maximum	(l/s)	333.2	333.2	333.2	333.2
Nominal water connection size (Grooved coupling)	(in)	10	10	10	10
Dimensions					
Unit Length	(mm)	5521	5521	5521	5521
Unit Width	(mm)	2088	2088	2088	2088
Unit Height	(mm)	2457	2457	2457	2457
Weights					
Shipping Weight	(kg)	13570	13680	13790	13790
Operating Weight	(kg)	14360	14470	14590	14590
System data (5)					
Nb of refrigerant circuit	#	2	2	2	2
Minimum cooling capacity per circuit %	%	30	30	30	30
Standard unit					
Refrigerant charge Circuit 1 / Circuit 2 (5)	(kg)	275/275	275/275	275/275	275/275
Oil charge Circuit 1 / Circuit 2 (5)	(l)	25/25	25/25	25/25	25/25
POE Oil type	#	OIL0066E/67E			

(1) Indicative performance at Evaporator water temperature: 12°C / 7°C - Condenser water temperature 30 / 35°C - for detailed performances consult order write up.

(2) Under 400V/3/50Hz.

(3) Option fuse + disconnect switch.

(4) Not applicable for Glycol application - see tables with Minimum Flow with Glycol.

(5) Electrical & system data are indicative and subject to change without notice. Please refer to unit nameplate data.

General Data

Table 4 – General Data RTHF Extra Efficiency (XE) - R1234ze

		RTHF 250 XE	RTHF 270 XE	RTHF 305 XE	RTHF 335 XE	RTHF 370 XE	RTHF 400 XE	RTHF 445 XE	RTHF 490 XE
Indicative performances (1)									
Gross Cooling Capacity (1)	(kW)	853	943	1087	1170	1313	1401	1580	1686
Gross Total Power input in cooling (1)	(kW)	145	161	187	202	228	242	251	272
Unit Electrical data (2) (5)									
Maximum Power Input	(kW)	291	291	355	355	419	419	490	561
Unit rated amps (2)	(A)	466	466	582	582	698	698	804	910
Unit start up amps (2)	(A)	645	645	761	761	829	829	1097	1203
Displacement power factor	#	0.9	0.9	0.88	0.88	0.87	0.87	0.88	0.89
Short Circuit Unit Capacity	(kA)	35	35	35	35	35	35	35	35
Max Power cable (cross)	(mm ²)	2 x 300	2 x 300	2 x 300	2 x 300	2 x 300	2 x 300	4 x 185	4 x 185
Disconnect switch size (3)	(A)	800	800	800	800	800	800	1250	1250
Compressor									
Compressor Number per Circuit	#	1	1	1	1	1	1	1	1
Type	#	Screw	Screw	Screw	Screw	Screw	Screw	Screw	Screw
Model	#	B1/B1	B2/B2	C1/B2	C2/B2	C2/C1	C2/C2	D1/C2	D1/D1
Max compr Power input Circuit 1 / Circuit 2	(kW)	145/145	145/145	209/145	209/145	209/209	209/209	280/209	280/280
Max Amps Circuit 1 / Circuit 2	(A)	233/233	233/233	349/233	349/233	349/349	349/349	455/349	455/455
Motor max RPM (variable speed)	(RPM)	3000	3000	3000	3000	3000	3000	3000	3000
Oil sump heater Circuit 1 / Circuit 2	(kW)	0.3/0.3	0.3/0.3	0.3/0.3	0.3/0.3	0.3/0.3	0.3/0.3	0.3/0.3	0.3/0.3
Evaporator									
Quantity	#	1	1	1	1	1	1	1	1
Type	#	Flooded shell and tube heat exchanger							
Evaporator model	#	516A	516A	580A	580A	580A	580A	800A	800A
Evaporator Content volume	(l)	172	172	211	211	211	211	324	324
One pass evaporator									
Evap. Water Flow rate - Minimum (4)	(l/s)	34.6	34.6	39.4	39.4	39.4	39.4	63.8	63.8
Evap. Water Flow rate - Maximum (4)	(l/s)	127.4	127.4	144.6	144.6	144.6	144.6	234	234
Nominal water connection size (Grooved coupling)	(in)	8	8	8	8	8	8	10	10
One pass with turbulator evaporator									
Evap. Water Flow rate - Minimum (4)	(l/s)	28.8	28.8	32.8	32.8	32.8	32.8	53.2	53.2
Evap. Water Flow rate - Maximum (4)	(l/s)	115.8	115.8	131.5	131.5	131.5	131.5	212.7	212.7
Nominal water connection size (Grooved coupling)	(in)	8	8	8	8	8	8	10	10
Condenser									
Quantity	#	1	1	1	1	1	1	1	1
Type	#	Shell and tube heat exchanger							
Condenser model	#	501C	501A	550A	550A	550A	550A	800B	800A
Condenser Water Content Volume	(l)	273	304	369	369	369	369	364	452
One pass condenser									
Cond. Water Flow rate - Minimum	(l/s)	44.1	50.3	56.7	56.7	56.7	56.7	63.12	63.12
Cond. Water Flow rate -Maximum	(l/s)	161.6	184.2	207.7	207.7	207.7	207.7	231.43	231.43
Nominal water connection size (Grooved coupling)	(in)	8	8	8	8	8	8	10	10
Dimensions									
Unit Length	(mm)	4586	4586	4586	4586	4586	4586	5521	5521
Unit Width	(mm)	1840	1840	1840	1840	1840	1840	2088	2088
Unit Height	(mm)	2395	2395	2395	2395	2395	2395	2457	2457
Weights									
Shipping Weight	(kg)	7037	7073	8198	8198	9132	9132	12176	12561
Operating Weight	(kg)	7508	7560	8745	8745	9679	9679	12881	13356
System data (5)									
Nb of refrigerant circuit	#	2	2	2	2	2	2	2	2
Minimum cooling capacity per circuit %	%	30	30	30	30	30	30	30	30
Standard unit									
Refrigerant charge Circuit 1 / Circuit 2 (5)	(kg)	165/165	165/166	175/175	175/175	175/175	175/175	295/305	295/290
Oil charge Circuit 1 / Circuit 2 (5)	(l)	10/10	10/10	10/10	10/10	10/10	10/10	22/10	22/22
POE Oil type	#	OIL00315/317							

(1) Indicative performance at Evaporator water temperature: 12°C / 7°C - Condenser water temperature 30 / 35°C - for detailed performances consult order write up.

(2) Under 400V/3/50Hz.

(3) Option fuse + disconnect switch.

(4) Not applicable for Glycol application - see tables with Minimum Flow with Glycol.

(5) Electrical & system data are indicative and subject to change without notice. Please refer to unit nameplate data.

General Data

Table 4 – General Data RTHF Extra Efficiency (XE) - R1234ze (Continued)

		RTHF 520 XE	RTHF 560 XE	RTHF 595 XE	RTHF 630 XE
Indicative performances (1)					
Gross Cooling Capacity (1)	(kW)	1883	1964	2071	2178
Gross Total Power input in cooling (1)	(kW)	295	317	344	370
Unit Electrical data (2) (5)					
Maximum Power Input	(kW)	561	561	582	603
Unit rated amps (2)	(A)	910	910	943	976
Unit start up amps (2)	(A)	1203	1203	1236	1236
Displacement power factor	#	0.89	0.89	0.89	0.89
Short Circuit Unit Capacity	(kA)	35	35	35	35
Max Power cable (cross)	(mm ²)	4 x 185	4 x 185	4 x 185	4 x 185
Disconnect switch size (3)	(A)	1250	1250	1250	1250
Compressor					
Compressor Number per Circuit	#	1	1	1	1
Type	#	Screw	Screw	Screw	Screw
Model	#	D2/D2	D3/D3	E3/D3	E3/E3
Max compr Power input Circuit 1 / Circuit 2	(kW)	280/280	280/280	301/280	301/301
Max Amps Circuit 1 / Circuit 2	(A)	455/455	455/455	488/455	488/488
Motor max RPM (variable speed)	(RPM)	3000	3000	3000	3000
Oil sump heater Circuit 1 / Circuit 2	(kW)	0.3/0.3	0.3/0.3	0.3/0.3	0.3/0.3
Evaporator					
Quantity	#	1	1	1	1
Type	#	Shell and tube heat exchanger			
Evaporator model	#	800A	800A	800A	800A
Evaporator Content volume	(l)	324	324	324	324
One pass evaporator					
Evap. Water Flow rate - Minimum (4)	(l/s)	63.8	63.8	63.8	63.8
Evap. Water Flow rate - Maximum (4)	(l/s)	234	234	234	234
Nominal water connection size (Grooved coupling)	(in)	10	10	10	10
One pass with turbulator evaporator					
Evap. Water Flow rate - Minimum (4)	(l/s)	53.2	53.2	53.2	53.2
Evap. Water Flow rate - Maximum (4)	(l/s)	212.7	212.7	212.7	212.7
Nominal water connection size (Grooved coupling)	(in)	10	10	10	10
Condenser					
Quantity	#	1	1	1	1
Type	#	Shell and tube heat exchanger			
Condenser model	#	800A	800A	800A	800A
Condenser Water Content Volume	(l)	452	452	452	452
One pass condenser					
Cond. Water Flow rate - Minimum	(l/s)	90.87	90.87	90.87	90.87
Cond. Water Flow rate - Maximum	(l/s)	333.2	333.2	333.2	333.2
Nominal water connection size (Grooved coupling)	(in)	10	10	10	10
Dimensions					
Unit Length	(mm)	5521	5521	5521	5521
Unit Width	(mm)	2088	2088	2088	2088
Unit Height	(mm)	2457	2457	2457	2457
Weights					
Shipping Weight	(kg)	12561	12561	12661	12771
Operating Weight	(kg)	13356	13356	13456	13566
System data (5)					
Nb of refrigerant circuit	#	2	2	2	2
Minimum cooling capacity per circuit %	%	30	30	30	30
Standard unit					
Refrigerant charge Circuit 1 / Circuit 2 (5)	(kg)	295/290	295/290	285/290	285/285
Oil charge Circuit 1 / Circuit 2 (5)	(l)	22/22	22/22	22/22	22/22
POE Oil type	#	OIL00315/317			

(1) Indicative performance at Evaporator water temperature: 12°C / 7°C - Condenser water temperature 30 / 35°C - for detailed performances consult order write up.

(2) Under 400V/3/50Hz.

(3) Option fuse + disconnect switch.

(4) Not applicable for Glycol application - see tables with Minimum Flow with Glycol.

(5) Electrical & system data are indicative and subject to change without notice. Please refer to unit nameplate data.

General Data

Table 5 – General Data High Seasonal Efficiency (HSE) - R1234ze

		RTHF 270 HSE	RTHF 295 HSE	RTHF 320 HSE	RTHF 355 HSE	RTHF 405 HSE	RTHF 440 HSE	RTHF 480 HSE	RTHF 535 HSE
Indicative performances (1)									
Gross Cooling Capacity (1)	(kW)	928	1017	1105	1213	1396	1523	1658	1811
Gross Total Power input in cooling (1)	(kW)	166	189	211	245	264	283	318	370
Unit Electrical data (2) (5)									
Maximum Power Input	(kW)	260	318	318	318	349	381	381	381
Unit rated amps (2)	(A)	394	483	483	483	530	578	578	578
Unit start up amps (2)	(A)	394	483	483	483	530	578	578	578
Displacement power factor	#	0.95	0.95	0.95	0.95	0.95	0.95	0.95	0.95
Short Circuit Unit Capacity	(kA)	35	35	35	35	35	35	35	35
Max Power cable (cross)	(mm ²)	2 x 300	2 x 300	2 x 300	2 x 300	2 x 300	2 x 300	2 x 300	2 x 300
Disconnect switch size (3)	(A)	800	800	800	800	800	800	800	800
Compressor									
Compressor Number per Circuit	#	1	1	1	1	1	1	1	1
Type	#	Screw	Screw	Screw	Screw	Screw	Screw	Screw	Screw
Model	#	B2/B2	B2/B2	B2/B2	B2/B2	C2/B2	C2/C2	C2/C2	C2/C2
Max compr Power input Circuit 1 / Circuit 2	(kW)	130/130	159/159	159/159	159/159	190/159	190/190	190/190	190/190
Max Amps Circuit 1 / Circuit 2	(A)	197/197	241/241	241/241	241/241	289/241	289/289	289/289	289/289
Motor max RPM (variable speed)	(RPM)	3000	3300	3600	3900	3600	3300	3600	4020
Oil sump heater Circuit 1 / Circuit 2	(kW)	0.3/0.3	0.3/0.3	0.3/0.3	0.3/0.3	0.3/0.3	0.3/0.3	0.3/0.3	0.3/0.3
Evaporator									
Quantity	#	1	1	1	1	1	1	1	1
Type	#	Flooded shell and tube heat exchanger							
Evaporator model	#	516A	516A	516A	516A	580A	580A	580A	580A
Evaporator Content volume	(l)	172	172	172	172	211	211	211	211
One pass evaporator									
Evap. Water Flow rate - Minimum (4)	(l/s)	34.6	34.6	34.6	34.6	39.4	39.4	39.4	39.4
Evap. Water Flow rate - Maximum (4)	(l/s)	127.4	127.4	127.4	127.4	144.6	144.6	144.6	144.6
Nominal water connection size (Grooved coupling)	(in)	8	8	8	8	8	8	8	8
One pass with turbulator evaporator									
Evap. Water Flow rate - Minimum (4)	(l/s)	28.8	28.8	28.8	28.8	32.8	32.8	32.8	32.8
Evap. Water Flow rate - Maximum (4)	(l/s)	115.8	115.8	115.8	115.8	131.5	131.5	131.5	131.5
Nominal water connection size (Grooved coupling)	(in)	8	8	8	8	8	8	8	8
Condenser									
Quantity	#	1	1	1	1	1	1	1	1
Type	#	Shell and tube heat exchanger							
Condenser model	#	501C	501A	501A	501A	550A	550A	550A	550A
Condenser Water Content Volume	(l)	273	304	304	304	369	369	369	369
One pass condenser									
Cond. Water Flow rate - Minimum	(l/s)	44.1	50.3	50.3	50.3	56.7	56.7	56.7	56.7
Cond. Water Flow rate -Maximum	(l/s)	161.6	184.2	184.2	184.2	207.7	207.7	207.7	207.7
Nominal water connection size (Grooved coupling)	(in)	8	8	8	8	8	8	8	8
Dimensions									
Unit Length	(mm)	4586	4586	4586	4586	4586	4586	4586	4586
Unit Width	(mm)	1940	1940	1940	1940	1940	1940	1940	1940
Unit Height	(mm)	2395	2395	2395	2395	2395	2395	2395	2395
Weights									
Shipping Weight	(kg)	7243	7233	7233	7233	8413	9412	9412	9412
Operating Weight	(kg)	7730	7720	7720	7720	8960	9959	9959	9959
System data (5)									
Nb of refrigerant circuit	#	2	2	2	2	2	2	2	2
Minimum cooling capacity per circuit %	%	30	30	30	30	30	30	30	30
Standard unit									
Refrigerant charge Circuit 1 / Circuit 2 (5)	(kg)	165/165	160/160	160/160	160/160	170/170	170/170	170/170	170/170
Oil charge Circuit 1 / Circuit 2 (5)	(l)	10/10	10/10	10/10	10/10	10/10	10/10	10/10	10/10
POE Oil type	#	OIL00315/317							

(1) Indicative performance at Evaporator water temperature: 12°C / 7°C - Condenser water temperature 30 / 35°C - for detailed performances consult order write up.

(2) Under 400V/3/50Hz.

(3) Option fuse + disconnect switch.

(4) Not applicable for Glycol application.

(5) Electrical & system data are indicative and subject to change without notice. Please refer to unit nameplate data.

General Data

Table 5 – General Data High Seasonal Efficiency (HSE) - R1234ze (Continued)

		RTHF 560 HSE	RTHF 595 HSE	RTHF 630 HSE	RTHF 680 HSE	RTHF 720 HSE	RTHF 780 HSE
Indicative performances (1)							
Gross Cooling Capacity (1)	(kW)	1965	2110	2255	2414	2588	2759
Gross Total Power input in cooling (1)	(kW)	315	347	379	431	483	536
Unit Electrical data (2) (5)							
Maximum Power Input	(kW)	460	460	460	574	574	578
Unit rated amps (2)	(A)	698	698	698	872	872	877
Unit start up amps (2)	(A)	698	698	698	872	872	877
Displacement power factor	#	0.95	0.95	0.95	0.95	0.95	0.95
Short Circuit Unit Capacity	(kA)	35	35	35	35	35	35
Max Power cable (cross)	(mm ²)	4 x 185	4 x 185	4 x 185	4 x 185	4 x 185	4 x 185
Disconnect switch size (3)	(A)	1250	1250	1250	1250	1250	1250
Compressor							
Compressor Number per Circuit	#	1	1	1	1	1	1
Type	#	Screw	Screw	Screw	Screw	Screw	Screw
Model	#	D3/D3	E3/D3	E3/E3	E3/E3	E3/E3	E3/E3
Max compr Power input Circuit 1 / Circuit 2	(kW)	229/229	229/229	229/229	287/287	287/287	289/289
Max Amps Circuit 1 / Circuit 2	(A)	349/349	349/349	349/349	436/436	436/436	438/438
Motor max RPM (variable speed)	(RPM)	3000	3000	3000	3300	3600	3900
Oil sump heater Circuit 1 / Circuit 2	(kW)	0.3/0.3	0.3/0.3	0.3/0.3	0.3/0.3	0.3/0.3	0.3/0.3
Evaporator							
Quantity	#	1	1	1	1	1	1
Type	#	Flooded shell and tube heat exchanger					
Evaporator model	#	800A	800A	800A	800A	800A	800A
Evaporator Content volume	(l)	324	324	324	324	324	324
One pass evaporator							
Evap. Water Flow rate - Minimum (4)	(l/s)	63.8	63.8	63.8	63.8	63.8	63.8
Evap. Water Flow rate - Maximum (4)	(l/s)	234	234	234	234	234	234
Nominal water connection size (Grooved coupling)	(in)	10	10	10	10	10	10
One pass with turbulator evaporator							
Evap. Water Flow rate - Minimum (4)	(l/s)	53.2	53.2	53.2	53.2	53.2	53.2
Evap. Water Flow rate - Maximum (4)	(l/s)	212.7	212.7	212.7	212.7	212.7	212.7
Nominal water connection size (Grooved coupling)	(in)	10	10	10	10	10	10
Condenser							
Quantity	#	1	1	1	1	1	1
Type	#	Shell and tube heat exchanger					
Condenser model	#	800A	800A	800A	800A	800A	800A
Condenser Water Content Volume	(l)	452	452	452	452	452	452
One pass condenser							
Cond. Water Flow rate - Minimum	(l/s)	63.12	63.12	90.87	90.87	90.87	90.87
Cond. Water Flow rate -Maximum	(l/s)	231.43	231.43	333.2	333.2	333.2	333.2
Nominal water connection size (Grooved coupling)	(in)	10	10	10	10	10	10
Dimensions							
Unit Length	(mm)	5521	5521	5521	5521	5521	5521
Unit Width	(mm)	2088	2088	2088	2088	2088	2088
Unit Height	(mm)	2457	2457	2457	2457	2457	2457
Weights							
Shipping Weight	(kg)	12881	13021	13131	13131	13131	13131
Operating Weight	(kg)	13676	13816	13926	13926	13926	13926
System data (5)							
Nb of refrigerant circuit	#	2	2	2	2	2	2
Minimum cooling capacity per circuit %	%	30	30	30	30	30	30
Standard unit							
Refrigerant charge Circuit 1 / Circuit 2 (5)	(kg)	295/290	285/290	285/285	285/285	285/285	285/285
Oil charge Circuit 1 / Circuit 2 (5)	(l)	22/22	22/22	22/22	22/22	22/22	22/22
POE Oil type	#	OIL00315/317					

(1) Indicative performance at Evaporator water temperature: 12°C / 7°C - Condenser water temperature 30 / 35°C - for detailed performances consult order write up.

(2) Under 400V/3/50Hz.

(3) Option fuse + disconnect switch.

(4) Not applicable for Glycol application.

(5) Electrical & system data are indicative and subject to change without notice. Please refer to unit nameplate data.

Unit Description

Figure 1 – Component Location for Typical RTHF Unit

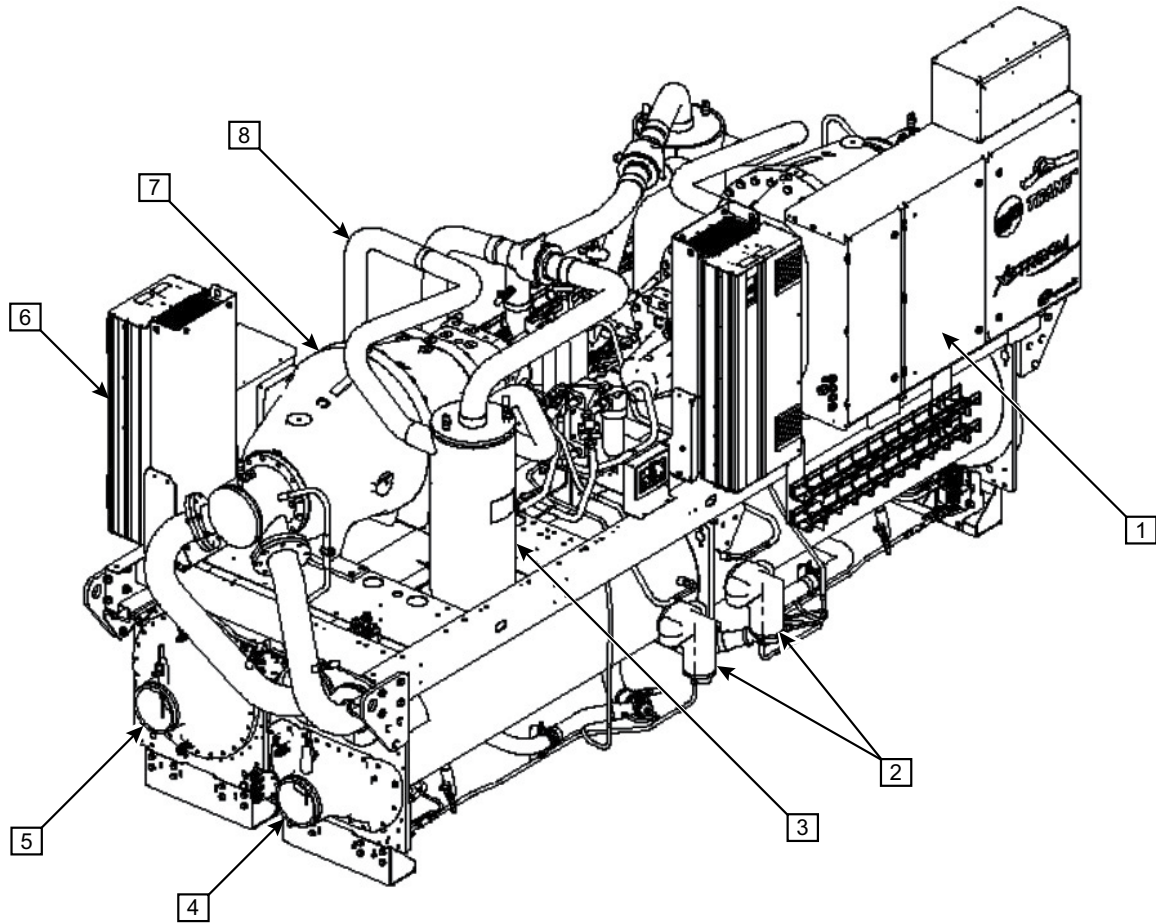

1	Control panel
2	Spillover (not present on R1234ze unit)
3	Oil separator
4	Evaporator water outlet
5	Condenser water inlet
6	Adaptive Frequency Drive (HSE version only)
7	Compressor
8	Discharge line

Note: Detailed location is given on the submittal drawing shipped with the unit.

Unit Description

Installation overview and requirements.

Contractor responsibilities

A list of the contractor responsibilities typically associated with the RTHF installation process is provided in Table 6.

- Locate and maintain the loose parts. Loose parts are located in the control panel.
- Install the unit on a foundation with flat support surfaces, level within 5 mm and of sufficient strength to support concentrated loading. Place the manufacturer-supplied isolation pad assemblies under the unit.
- Install the unit per the instructions outlined in the "Mechanical Installation" section.
- Complete all water piping and electrical connections.

Note: Field piping must be arranged and supported to avoid stress on the equipment. It is strongly recommended that the piping contractor provide at least 1m of clearance between the pre-installation piping and the planned location of the unit. This will allow for proper fit-up upon arrival of the unit at the installation site. All necessary piping adjustments can be made at that time

- Where specified, supply and install valves in the water piping upstream and downstream of the evaporator and condenser water boxes, to isolate the shells for maintenance and to balance/trim the system.

- Supply and install flow switches or equivalent devices in both the chilled water and condenser water piping. Interlock each switch with the proper pump starter and Tracer UC800, to ensure that the unit can only operate when water flow is established.
- Supply and install taps for thermometers and pressure gauges in the water piping, adjacent to the inlet and outlet connections of both the evaporator and the condenser.
- Supply and install drain valves on each water box.
- Supply and install vent cocks on each water box.
- Where specified, supply and install strainers ahead of all pumps and automatic modulating valves.
- Supply and install refrigerant pressure relief piping from the pressure relief to the atmosphere.
- Start the unit under supervision of a qualified service technician.
- Where specified, supply and insulate the evaporator and any other portion of the unit, as required, to prevent sweating under normal operating conditions.
- For unit-mounted starters, cutouts are provided at the top of the panel for line-side wiring.
- Supply and install the wire terminal lugs to the starter.
- Supply and install field wiring to the line-side lugs of the starter.

Table 6 – Installation Responsibility

Requirement	Trane supplied Trane installed	Trane supplied Field installed	Customer supplied Customer installed
Foundation			Meet foundation requirements
Rigging			Safety chains Clevis connectors Lifting beams
Isolation		Isolation pads	Other type of isolators
Electrical	- Circuit breakers or fusible disconnects (Optional) - Unit mounted starter - Wye Delta starter or AFD (Adaptive Frequency Drive)	- Flow switches (may be field supplied) - Harmonic filters (on request according to customer electrical network and equipment) - Junction box on control panel	- Circuit breakers or fusible disconnect - Electrical connections to unit mounted starter (optional) - Electrical connections to remote mounted starter (optional) - Wiring sizes per submittal and local regulations - Terminal lugs - Ground connections - BAS wiring (optional) - Control voltage wiring - Chilled water pump contactor and wiring including interlock - Option relays and wiring
Water piping		Flow switches (may be field supplied)	- Taps for thermometers and gauges - Thermometers - Strainers (as required) - Water flow pressure gauges - Isolation and balancing valves in water piping - Vents and drain on waterbox valves - Pressure relief valves for water side
Insulation	Insulation		Insulation
Water piping connection components	- Grooved pipe - Return pipe to get inlet and outlet on same side (optional) - Grooved pipe to flagged connection (optional)		
Caution on exposure to refrigerant			Respect recommendation of IOM addendum



Installation - Mechanical

Storage

If the chiller is to be stored more than one month prior to installation, observe the following precautions:

- Do not remove the protective coverings from the electrical panel.
- Store the chiller in a dry, vibration-free, secure area.
- At least every three months, attach a gauge and manually check the pressure in the refrigerant circuit. If the refrigerant pressure is below 5 bar at 21°C (3 bar at 10 °C), call a qualified service organization and the appropriate Trane sales office.

NOTE: Pressure will be approximately 1.0 bar if shipped with the optional nitrogen charge.

Noise Considerations

- Refer to Engineering Bulletin for sound consideration applications.
- Locate the unit away from sound-sensitive areas.
- Install the isolation pads under the unit. Refer to "Unit Isolation."
- Install rubber vibration isolators in all water piping.
- Use flexible electrical conduit for final connection to the Tracer UC800.
- Seal all wall penetrations.

NOTE: Consult an acoustical engineer for critical applications.

Foundation

Provide rigid, non-warping mounting pads or a concrete foundation of sufficient strength and mass to support the chiller operating weight (including completed piping and full operating charges of refrigerant, oil and water).

Refer to General information for unit operating weights.

Once in place, level the chiller within 6 mm over its length and width.

The manufacturer is not responsible for equipment problems resulting from an improperly designed or constructed foundation.

Vibration Eliminators

- Provide rubber boot type isolators for all water piping at the unit.
- Provide flexible conduit for electrical connections to the unit.
- Isolate all pipe hangers and be sure they are not supported by main structure beams that could introduce vibration into occupied spaces.
- Make sure that the piping does not put additional stress on the unit.

NOTE: Do not use metal braided type eliminators on the water piping. Metal braided eliminators are not effective at the frequencies at which the unit will operate.

Clearances

Provide enough space around the unit to allow the installation and maintenance personnel unrestricted access to all service points. A minimum of 1 m is recommended for compressor service and to provide sufficient clearance for the opening of control panel doors. Refer to submittals (documents supplied in document package coming with unit) for minimum clearances required for condenser or evaporator tube service. In all cases, local codes will take precedence over these recommendations. If the room configuration requires a variance to the clearance dimensions, contact your sales representative.

NOTE: Required vertical clearance above the unit is at least 1 m. There should be no piping or conduit located over the compressor motor.

NOTE: Maximum clearances are given. Depending on the unit configuration, some units may require less clearance than others in the same category. Heat exchanger tube removal clearance is necessary for detubing and retubing.

Ventilation

The unit produces heat even though the compressor is cooled by the refrigerant. Make provisions to remove heat generated by unit operation from the equipment room. Ventilation must be adequate to maintain an ambient temperature lower than 40°C. Vent the pressure relief valves in accordance with all local and national codes. Refer to "Pressure Relief Valves." Make provisions in the equipment room to keep the chiller from being exposed to ambient temperatures below 10°C.

Water Drainage

Locate the unit near a large capacity drain for water vessel drain-down during shutdown or repair. Condensers and evaporators are provided with drain connections. Refer to "Water Piping." All local and national codes apply.

Access Restrictions

Refer to the unit submittals for specific dimensional information (documents supplied in document package coming with unit).

Installation - Mechanical

Lifting Procedure

WARNING

Heavy Equipment!

Always use lifting equipment with a capacity exceeding unit lifting weight by an adequate safety factor. Follow the instructions given in the lifting and handling document and submittal supplied with documentation package shipped with the unit. Failure to do so can result in death personal injury.

CAUTION

Equipment Damage!

Never use a forklift to move the unit. The skid is not designed to support the unit at any one point and using a forklift to move the equipment may cause unit damage. Always position the lifting beam so that cables do not contact the unit. Failure to do so may result in unit damage.

NOTE: If absolutely necessary, the chiller can be pushed or pulled across a smooth surface if it is bolted to wood shipping mounts.

WARNING:

Shipping Mounts!

Do not use the threaded holes in the compressor to lift or assist in lifting the unit. They are not intended for that purpose. Do not remove the wood mounts (option) until the unit is in its final location. Removal of wood shipping mounts prior to unit final locating could result in death or serious injury or equipment damage.

1. When the unit is at its final location, remove the shipping bolts that secure the unit to the wood base mounts (option).
2. Rig the unit properly and lift from above or jack the unit (alternate moving method). Use the points shown on the rigging diagram that ships with the unit. Remove the base mounts.
3. Install clevis connectors in lifting holes provided on the unit. Attach lifting chains or cables to clevis connectors. Each cable alone must be strong enough to lift the chiller.
4. Attach cables to lifting beam. Total lifting weight, lifting weight distribution and required lifting beam dimensions are shown in the rigging diagram shipped with each unit. The lifting beam crossbar must be positioned so the lifting cables do not contact unit piping or electrical panel enclosure.

NOTE: The anti-rotation strap is not a lifting chain, but a safety device to ensure that the unit cannot tilt during lifting.

Alternate Moving Method

5. If it is not possible to rig from above as shown in the figures, the unit may also be moved by jacking each end high enough to move an equipment dolly under each tube sheet support. Once securely mounted on the dollies, the unit may be rolled into position.

WARNING: Connect an anti-rotation strap between the lifting beam and compressor before lifting unit. Failure to do so may result in death or serious injury should a lifting cable fail.

Lifting and handling drawings are included in the document package sent with the unit.

Figure 2 – Example of spreader to be used to lift RTHF

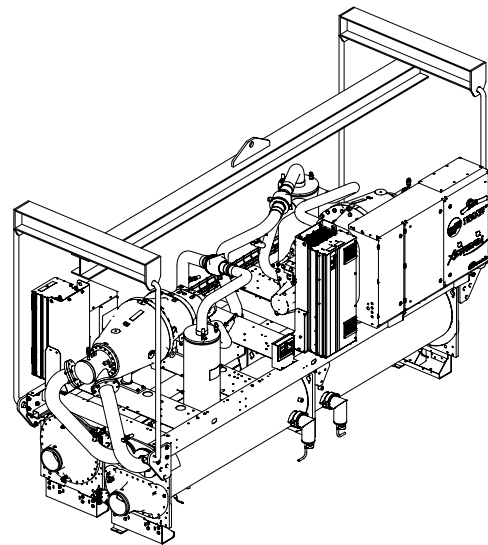

Isolation Pads

6. The elastomeric pads shipped (as standard) are adequate for most installations. For additional details on isolation practices, consult an acoustical engineer for sensitive installations. For AFD version, it is possible that some vibration frequencies can be transmitted into the foundations. This depends on the building structure. It is recommended for these situations to use neoprene isolators instead of elastomeric pads. Drawings to locate isolation pads are supplied with unit document package.
7. During final positioning of the unit, place the isolation pads under the evaporator and condenser tube sheet supports. Level the unit.
8. The unit is shipped with spacers on the compressor mount that protect the compressor isolation pads during shipping and in handling. Remove these spacers before the unit is operated.
9. Remove the shipping brackets and spacers of the oil separator(s).

Drawings to locate isolation pads are included with in document package sent with the unit.

Installation - Mechanical

Figure 3 – Shipping spacer and brackets to be removed prior to unit startup

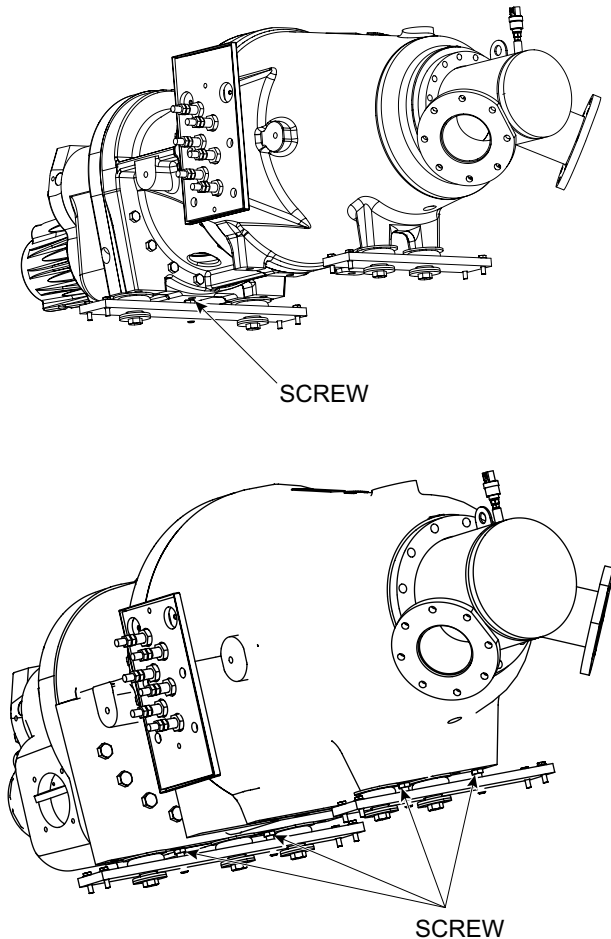

Unit Leveling

NOTE: The electrical panel side of the unit is designated as the “front” of the unit.

1. Check unit level end-to-end by placing a level on the top surface of the evaporator shell.
2. If there is insufficient surface available on the top of the evaporator shell, attach a magnetic level to the bottom of the shell to level the unit. The unit should be level to within 5 mm over its length.
3. Place the level on the evaporator shell tube sheet support to check side-to-side (front-to-back) level. Adjust to within 5 mm of level front-to-back. **NOTE:** The evaporator **MUST** be level for optimum heat transfer and unit performance.
4. Use full-length shims to level the unit.

Water Piping

Piping Connections

To prevent equipment damage, bypass the unit if using an acidic flushing agent.

Make water piping connections to the evaporator and condenser. Isolate and support piping to prevent stress on the unit. Construct piping according to local and national codes. Insulate and flush piping before connecting to unit.

The chilled water connections to the evaporator are to be grooved-pipe type connections. Do not attempt to weld these connections, as the heat generated from welding can cause microscopic and macroscopic fractures on the cast iron waterboxes that can lead to premature failure of the waterbox. Refer to submittal for dimension of tube stub for grooved connection

To prevent damage to chilled water components, do not allow evaporator pressure (maximum working pressure) to exceed 10 bar.

Reversing Water Boxes is prohibited

Heat exchanger are one pass evaporator and condenser. It is critical to keep the factory layout for water boxes. Therefore, reversing water boxes may lead to functional disorder.

NOTE: Dimensions of tube stub for grooved connection are included in submittal drawings.

Vents and Drains

Install pipe plugs in evaporator and condenser water box drain and vent connections before filling the water systems. To drain water, remove vent and drain plugs, install a NPT connector in the drain connection and connect a hose to it.

Water Treatment

WARNING: Do not use untreated or improperly treated water. Use of untreated or improperly treated water may result in equipment damage.

The following disclamatory label is provided on each RTHF unit:

The use of improperly treated or untreated water in this equipment may result in scaling, erosion, corrosion, algae or slime. The services of a qualified water treatment specialist should be engaged to determine what treatment, if any, is advisable. The warranty specifically excludes liability for corrosion, erosion or deterioration of the manufacturer's equipment. The manufacturer assumes no responsibilities for the results of the use of untreated or improperly treated water, or saline or brackish water.

At 65°C condensing leaving water temperature and above, it is mandatory to have condenser equipped with CuNi tubes.

Installation - Mechanical

Evaporator Piping Components

Note: Make sure all piping components are between the shutoff valves, so that isolation can be accomplished on both the condenser and the evaporator. "Piping components" include all devices and controls used to provide proper water system operation and unit operating safety. These components and their general locations are given below.

Entering Chilled Water Piping

- Air vents (to bleed air from system)
- Water pressure gauges with shutoff valves
- Pipe unions
- Vibration eliminators (rubber boots)
- Shutoff (isolation) valves
- Thermometers
- Clean out tees
- Pipe strainer

Leaving Chilled Water Piping

- Air vents (to bleed air from system)
- Water pressure gauges with shutoff valves
- Pipe unions
- Vibration eliminators (rubber boots)
- Shutoff (isolation) valves
- Thermometers
- Clean out tees
- Balancing valve
- Pressure relief valve

To prevent evaporator damage, do not exceed 10 bar evaporator water pressure for standard water boxes.

To prevent tube damage, install a strainer in the evaporator water inlet piping.

Condenser Piping Components

"Piping components" include all devices and controls used to provide proper water system operation and unit operating safety. These components and their general locations are given below.

Entering Condenser Water Piping

- Air vents (to bleed air from system)
- Water pressure gauges with shutoff valves
- Pipe unions
- Vibration eliminators (rubber boots)
- Shutoff (isolation) valves
- One per each pass
- **Thermometers**
- **Clean out tees**
- **Pipe strainer**
- **Flow switch**

Leaving Condenser Water Piping

- Air vents (to bleed air from system)
- Water pressure gauges with shutoff valves
- Pipe unions
- Vibration eliminators (rubber boots)
- Shutoff (isolation) valve
- One per each pass
- Thermometers
- Clean out tees
- Balancing valve
- Pressure relief valve

To prevent condenser damage, do not exceed 10 bar water pressure for standard water boxes.

To prevent tube damage, install a strainer in condenser water inlet piping.

Water Pressure Gauges and Thermometers

Install field-supplied thermometers and pressure gauges (with manifolds, whenever practical). Locate pressure gauges or taps in a straight run of pipe; avoid placement near elbows, etc. Be sure to install the gauges at the same elevation on each shell if the shells have opposite-end water connections.



Installation - Mechanical

Water Pressure Relief Valves

Install a pressure relief valve in both evaporator and condenser water systems. Failure to do so could result in shell damage.

Install a water pressure relief valve in one of the condenser and one of the evaporator water box drain connections or on the shell side of any shutoff valve. Water vessels with close-coupled shutoff valves have a high potential for hydrostatic pressure buildup on a water temperature increase. Refer to applicable regulation for relief valve installation guidelines.

Flow Sensing Devices

Use field-provided flow switches or differential pressure switches with pump interlocks to sense system water flow. Flow switch locations are schematically shown in Figure.

To provide chiller protection, install and wire flow switches in series with the water pump interlocks, for both chilled water and condenser water circuits (refer to the "Installation Electrical" section). Specific connections and schematic wiring diagrams are shipped with the unit.

Flow switches must stop or prevent compressor operation if either system water flow drops off drastically. Follow the manufacturer's recommendations for selection and installation procedures. General guidelines for flow switch installation are outlined below.

- Mount the switch upright, with a minimum of 10 pipe diameters of straight, horizontal run on each side.
- Do not install close to elbows, orifices or valves.

Note: The arrow on the switch must point in the direction of the water flow. To prevent switch fluttering, remove all air from the water system.

Note: The Tracer UC800 provides a 6-second time delay on the flow switch input before shutting down the unit on a loss-of-flow diagnostic. Contact a qualified service organization if nuisance machine shutdowns persist. Adjust the switch to open when water flow falls below nominal. Refer to the General Data table for minimum flow recommendations for specific water pass arrangements. Flow switch contacts are closed on proof of water flow.

Refrigerant Pressure Relief Valve Venting

To prevent injury due to inhalation of refrigerant gas, do not discharge refrigerant anywhere. If multiple chillers are installed, each unit must have separate venting for its relief valves. Consult local regulations for any special relief line requirements.

All relief valve venting is the responsibility of the installing contractor. All RTHF units use condenser pressure relief valves that must be vented to the outside of the building. Relief valve connection sizes and locations are shown in the unit submittals. Refer to national regulations for relief valve vent line sizing information.

Do not exceed vent piping code specifications. Failure to heed specifications could result in capacity reduction, unit damage and/or relief valve damage.

Note: Once opened, relief valves tend to leak.

Installation - Mechanical

RTHF- Evaporator and Condenser Pressure drop

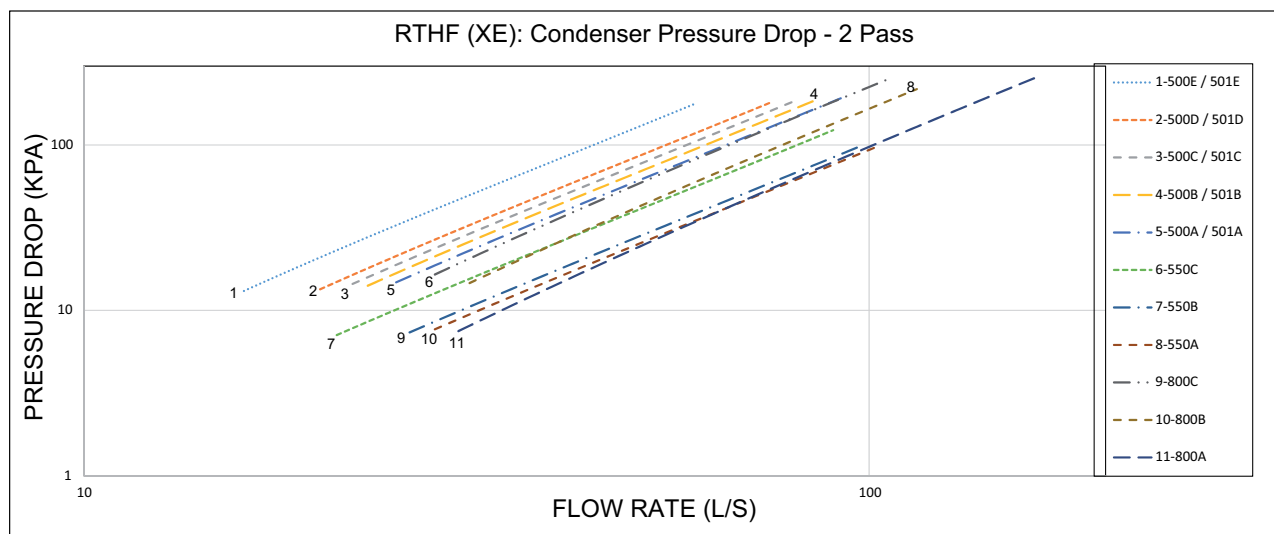
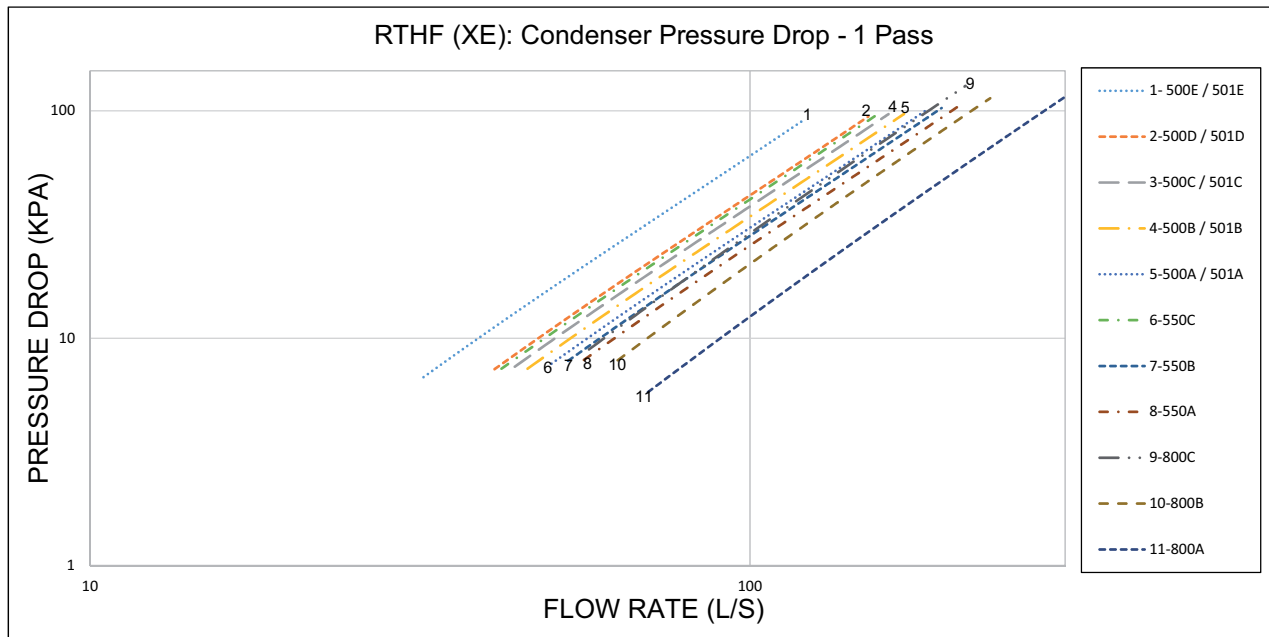

Note :

Water pressure drop are for pure water.
Limit of water flow are limit of the curves.

Installation - Mechanical

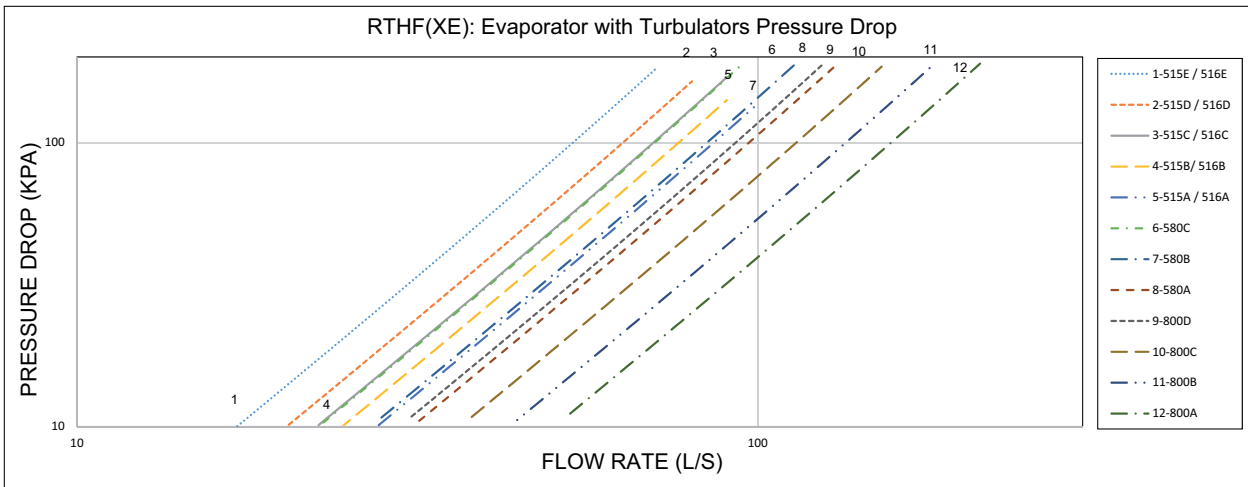
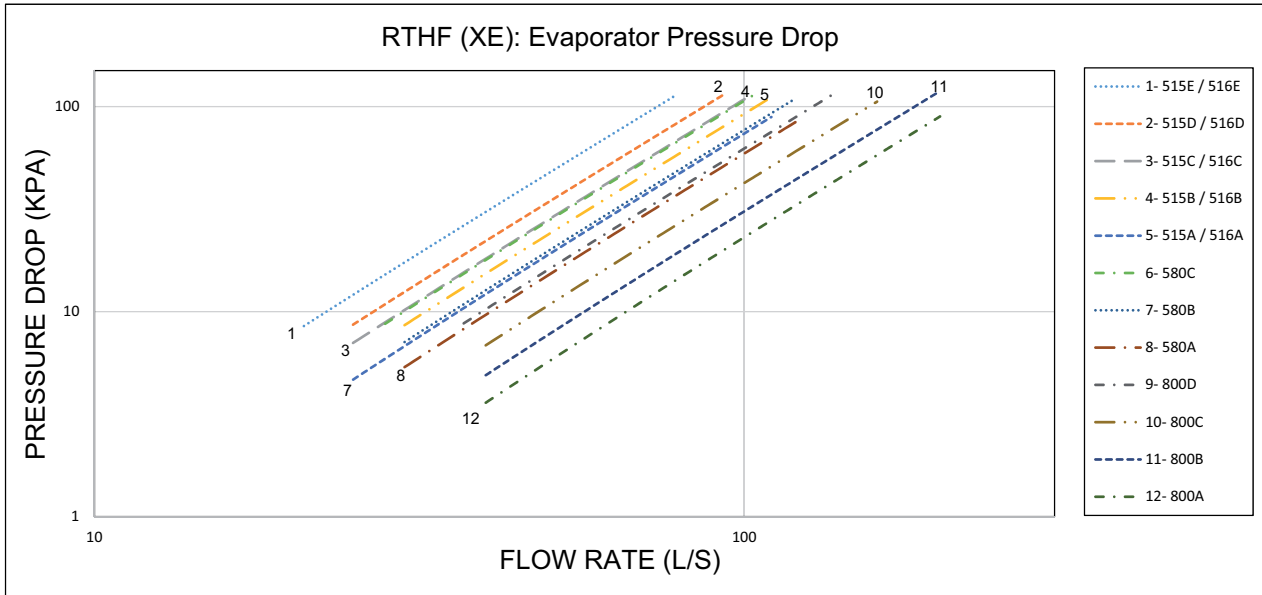

Freeze protection

For all chiller, it is extremely important to keep full water flow in the evaporator and condenser for an extended time after last compressor stops. This will protect evaporator tube from freezing by refrigerant migration.

This is why both evaporator and condenser water pump output relay must be used to control the chilled water pump. It is mandatory even if glycol is used with protection down to lowest ambient expected.

For unit operation in a low temperature environment, adequate protection measures must be taken against freezing. Freeze protection can be accomplished by adding sufficient glycol to protect against freezing below the lowest ambient expected.

Important: Be sure to apply appropriate LERTC (Low Evaporator Refrigerant Temperature Cutout) and LWTC (Low Water Temperature Cutout) control setpoints based on the concentration of the freeze inhibitor or solution freeze point temperature.

Avoid the use of very low or near minimum chilled fluid flow rates through the chiller. Higher velocity chilled fluid flow reduces freeze risk in all situations. Flow rates below published limits have increased freeze potential and have not been considered by freeze protection algorithms.

- Avoid applications and situations that result in a requirement for rapid cycling or repeated starting and stopping of the chiller. Keep in mind that chiller control algorithms may prevent a rapid compressor restart after shutting down when the evaporator has been operating near or below the LERTC limit.
- Maintain refrigerant charge at appropriate levels. If charge is in question, contact Trane service. A reduced or low level of charge can increase the likelihood of freezing conditions in the evaporator and/or LERTC diagnostic shutdowns.



Installation - Mechanical

RTHF Low Refrigerant temperature Ethylene Glycol and Propylene Glycol and Freeze protection settings.

Table 7 – Recommended low evaporator refrigerant temperature cutout (LERTC) and low water temperature cutout (LWTC) for RTHF chillers

Glycol Percentage (weight %)	Solution Freeze Point (°C)	Ethylene Glycol		Mono Propylene Glycol		
		Minimum Recommended LRTC (°C)	Minimum Recommended LWTC (°C)	Solution Freeze Point (°C)	Minimum Recommended LRTC (°C)	Minimum Recommended LWTC (°C)
0	0	0	2.8	0	0	2.8
2	-0.6	-1.4	2.2	-0.6	-1.4	2.2
4	-1.3	-2.1	1.5	-1.2	-2	1.6
5	-1.7	-2.5	1.1	-1.5	-2.3	1.3
6	-2	-2.9	0.7	-1.8	-2.6	1
8	-2.8	-3.6	0	-2.5	-3.3	0.3
10	-3.6	-4.5	-0.8	-3.1	-4	-0.4
12	-4.5	-5.3	-1.7	-3.8	-4.7	-1.1
14	-5.4	-6.2	-2.6	-4.6	-5.4	-1.8
15	-5.9	-6.7	-3.1	-5	-5.8	-2.2
16	-6.3	-7.2	-3.6	-5.4	-6.2	-2.6
18	-7.4	-8.2	-4.6	-6.2	-7	-3.4
20	-8.4	-9.3	-5.7	-7.1	-7.9	-4.3
22	-9.6	-10.4	-6.8	-8	-8.8	-5.2
24	-10.8	-11.6	-8	-9	-9.9	-6.3
25	-11.4	-12.3	-8.7	-9.6	-10.4	-6.8
26	-12.1	-12.9	-9.3	-10.1	-11	-7.4
28	-13.5	-14.3	-10.7	-11.3	-12.2	-8.5
30	-15	-15.8	-12.2	-12.6	-13.4	-9.8
32	-16.5	-17.3	-13.7	-14	-14.8	-11.2
34	-18.2	-19	-15	-15.5	-16.3	-12.7
35	-19	-19.9	-15	-16.3	-17.1	-13.5
36	-19.9	-20.6	-15	-17.1	-17.9	-14.3
38	-21.8	-20.6	-15	-18.8	-19.6	-15
40	-23.8	-20.6	-15	-20.7	-20.6	-15
42	-25.9	-20.6	-15	-22.6	-20.6	-15
44	-28.1	-20.6	-15	-24.8	-20.6	-15
45	-29.3	-20.6	-15	-25.9	-20.6	-15
46	-30.5	-20.6	-15	-27.1	-20.6	-15
48	-33	-20.6	-15	-29.5	-20.6	-15
50	-35.6	-20.6	-15	-32.1	-20.6	-15

CAUTION!

1. Additional glycol beyond the recommendations will adversely affect unit performance. The unit efficiency will be reduced and the saturated evaporator temperature will be reduced. For some operating conditions this effect can be significant.
2. If additional glycol is used, then use the actual % glycol to establish the low refrigerant cutout set point.
3. The minimum low refrigerant cutout set point allowed is -20.6°C. This minimum is established by the solubility limits of the oil in the refrigerant.

4. With glycol application, ensure that there is no fluctuation of brine flow versus Order Write Up value, as a reduction of flow will adversely affect unit performance and behaviour.
5. Tables above should not be interpreted as suggesting operating ability or performance characteristics at all tabulated glycol percentages. Full unit simulation is required for proper prediction of unit performance for specific operating conditions. For information on specific conditions, contact Trane.

Installation - Mechanical

Condenser Water Temperatures

With the model RTHF chiller, a condenser water control method is necessary only if the unit starts with entering water temperatures below 13°C, or between 7°C and 13°C, when a temperature increase of 0.6°C per minute to 13°C is not possible.

When the application requires startup temperatures below the prescribed minimums, a variety of options are available. To control a 2-way or 3-way valve, Trane offers a Condenser Regulating Valve Control option for the Tracer UC800 controls.

Condenser leaving water temperature must be 9°C higher than evaporator leaving water temperature within 2 minutes after start-up. A minimum of 14°C differential must be maintained afterwards.

The minimum acceptable refrigerant pressure differential between condenser and evaporator is 1.7 Bar. The chiller control system will attempt to obtain and maintain this differential at startup, but for continuous operation a design should maintain a 14°C differential from evaporator leaving water temperature to condenser leaving water temperature.

CAUTION! In case of low evaporator leaving water temperature applications, the non use of glycol on the condenser side may result in condenser tube freeze-up.

Condenser Water Regulation

The Condenser Head Pressure Control Option provides for a 0-10VDC (maximum range - a smaller range is adjustable) output interface to the customer's condenser water flow device. This option enables the Tracer UC800 controls to send a signal for opening and closing a 2-way or 3-way valve as necessary to maintain chiller differential pressure.

Methods other than those shown can be employed to achieve the same results. Contact your local Trane office for details.

Contact the manufacturer of the cooling device for compatibility with variable water flow.

Throttling valve (Figure 5)

This method maintains condensing pressure and temperature by throttling water flow leaving the condenser in response to condenser pressure or system differential pressures.

Advantages:

- Good control with proper valve sizing at relatively low cost.
- Pumping cost can be reduced.

Disadvantages:

- Increased rate of fouling due to lower condenser water velocity.
- Requires pumps that can accommodate variable flow.

Figure 5

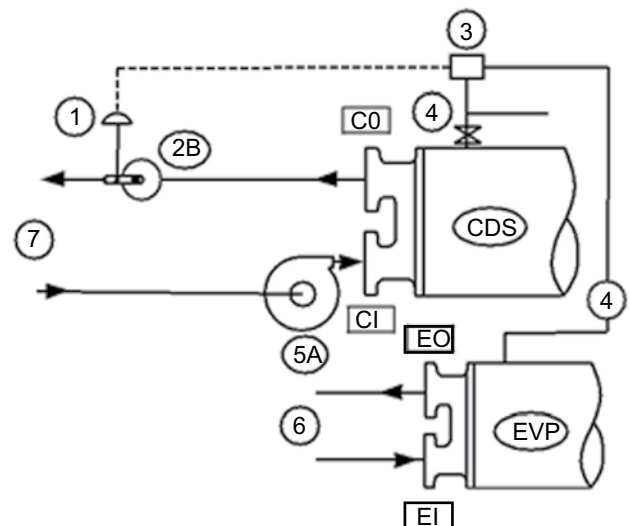

Installation - Mechanical

Cooling device bypass - Figure 6

Cooling device bypass is also a valid control method if the chiller temperature requirements can be maintained.

Advantage:

- Excellent control by maintaining constant water flow through the condenser.

Disadvantage:

- Higher cost because of the dedicated pump required for each chiller if condenser pressure is the control signal.

Figure 6

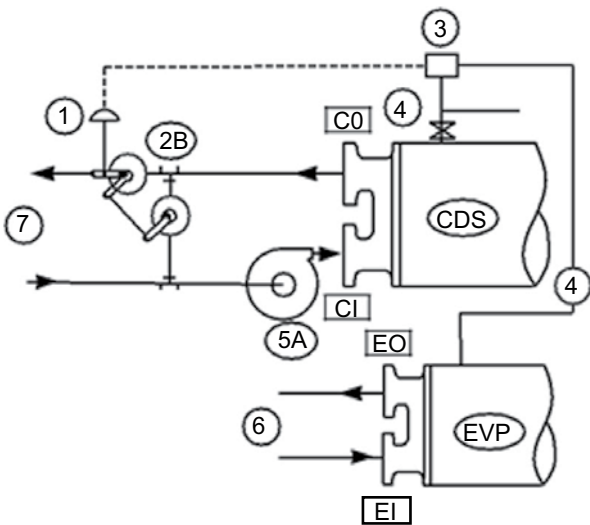

Condenser water pump with variable frequency drive - Figure 7

Advantages:

- Pumping cost can be reduced. Good cooling device temperature control.
- Relatively low first cost.

Disadvantage:

- Increased rate of fouling due to lower water velocity in the condenser.

Figure 7

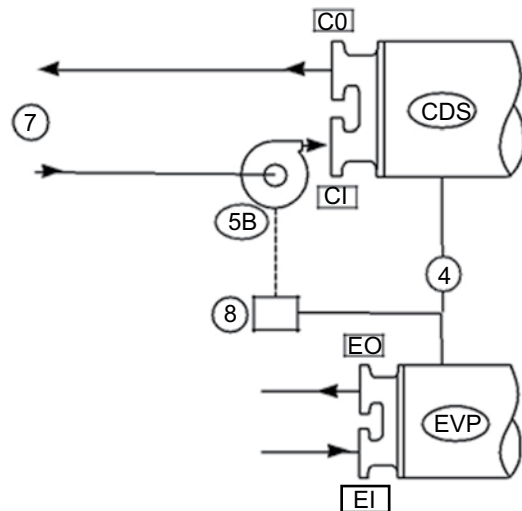

- 1 = Electric valve actuator
- 2A = 3-way valve or 2 butterfly valves
- 2B = 2 butterfly valves
- 3 = RTHD controller
- 4 = Refrigerant pressure line
- 5A = Condenser water pump
- 5B = Condenser water pump with VFD
- 6 = To/from cooling load
- 7 = To/from cooling device
- 8 = Electric controller
- EI = Evaporator Inlet
- EO = Evaporator Outlet
- CI = Condenser Inlet
- CO = Condenser Outlet

Condenser Water Regulating Valve Adjustment

A separate Settings Menu tab entitled "Condenser Head Pressure Control -Setup" that is only visible if the configuration is selected, contain the following settings and manual overrides for user adjustments and commissioning all under one tab:

- "Off State" Output Command (0-10 Vdc, 0.1 volt increments, Default 2.0 Vdc)
- Output Voltage @Desired Minimum Flow (Adj: 0 to 10.0 in 0.1 volt increments, Default 2.0 Vdc)
- Desired Minimum Flow (Adj:0-100% of full flow in 1%intervals, Default 20%)
- Output Voltage @Desired Maximum Flow (Adj: 0 to 10.0 in 0.1 volt increments (or finer),Default 10 Vdc)
- Actuator Stroke Time (Min to Max Range Time)(Adj: 1 to 1000 seconds, in 1 second increments, Default 30s)
- Damping Coefficient (adj: 0.1 to 1.8, in 0.1 increments, Default .5)
- Head Pressure Control Override (enumeration of: disabled (auto),"off" state, minimum, maximum (100%),) default : disabled (auto). When this setting is in "disabled (auto)"
- Condenser Water Pump Prerun Time

WARNING: In low temperature chilled water applications, in the case of a power loss, there is a risk of a condenser freeze-up. For low temperature chilled water applications, it is recommended to take freeze protection measures.

Installation - Electrical

General Recommendations

For proper electrical component operation, do not locate the unit in areas exposed to dust, dirt, corrosive fumes, or excessive humidity. If any of these conditions exist, corrective action must be taken.

When reviewing this manual keep in mind:

- All field-installed wiring must be in accordance with local regulations, CE directives and guidelines. Be sure to satisfy proper equipment grounding requirements according to CE.
- The following standardized values - Maximum Amps - Short Circuit Amps - Starting Amps are displayed on unit nameplate.
- All field-installed wiring must be checked for proper terminations, and for possible shorts or grounds.

Note: always refer to wiring diagrams shipped with chiller or unit submittal for specific electrical schematic and connection information.

Important: to prevent control malfunctions, do not run low voltage wiring (<30V) in conduit with conductors carrying more than 30 volts.

WARNING! Hazardous Voltage with Capacitor!

Disconnect all electric power, including remote disconnects and discharge all motor start/run and AFD (Adaptive Frequency™ Drive) capacitors before servicing. Follow proper lockout/tagout procedures to ensure the power cannot be inadvertently energized.

- For variable frequency drives or other energy storing components provided by Trane or others, refer to the appropriate manufacturer's literature for allowable waiting periods for discharges capacitors. Verify with an appropriate voltmeter that all capacitors have discharged.
- DC bus capacitors retain hazardous voltages after input power has been disconnected. Follow proper lockout/ tagout procedures to ensure the power cannot be inadvertently energized.

After disconnecting input power, wait twenty (20) minutes for units which are equipped with variable frequency drive (0V DC) before touching any internal components.

Failure to follow these instructions could result in death or serious injury.

For additional information regarding the safe discharge of capacitors, see "Adaptive Frequency™ Drive (AFD3) Capacitor Discharge".

- **However, for any intervention in the AFD, the indicated time on the label of the AFD must be respected.**

Before installing the chiller with AFD, the user must evaluate the potential electromagnetic problems in the surrounding area. The following should be considered:

- a) the presence above, below and adjacent to the unit of for example: welding equipment or other power cables, control cables or signalling and telephone cables;
- b) receivers and transmitters, radio and television;
- c) computer and other control equipment ;
- d) the critical safety equipment, eg protection of industrial equipment ;
- e) the health of neighbouring persons, for example, use of pacemakers or appliances against deafness ;
- f) the immunity of other equipment in the environment. The user must ensure that the other materials used in the environment are compatible. This may require additional protection measures ;

If electromagnetic disturbances are detected, it shall be the responsibility of the user to resolve the situation.

In any case, the electromagnetic interferences have to be reduced until they are no longer troublesome.

All wiring must comply with national electric regulations. Minimum circuit ampacities and other unit electrical data is on the unit nameplate. See the unit order specifications for actual electrical data. Specific electrical schematics and connection diagrams are shipped with the unit.

Do not allow conduit to interfere with other components, structural members or equipment. Control voltage (110V) wiring in conduit must be separate from conduit carrying low voltage (<30V) wiring. To prevent control malfunctions, do not run low voltage wiring (<30V) in conduit with conductors carrying more than 30V.

Power Supply Wiring

Model RTHF chillers are designed according to European standard EN 60204-1; therefore, all power supply wiring must be sized and selected accordingly by the project engineer.

Water Pump Power Supply

Provide power supply wiring with fused disconnect for both the chilled water and condenser water pumps.

Electrical Panel Power Supply

Power supply wiring instructions for the starter/control panel are:

Run the line voltage wiring in conduit to the access opening(s) on the starter/control panel. See the product catalogue for wire sizing and selection information and refer to general data that show typical electrical connection sizes and locations. Always refer to submittal information for your actual unit specifications.

Note: Asterisked connections require the user to provide an external source of power. The 110V control power transformer is not sized for additional load.

CAUTION

Unit with AFD version must not be linked to the neutral wiring of the installation.

Units are compatible with the following neutral operating conditions:

TNS	IT	TNC	TT
Standard	Special	Special	Special
	- on request	- on request	- on request

Differential protection should be suited for industrial machinery with current leak which can be higher than 500 mA (several motors and frequency drives).

CAUTION! To avoid corrosion, overheating or general damage, at terminal connections, unit is designed for copper Conductors only. In case of aluminum cable, bi-material connecting devices are mandatory. Cable routing inside control panel should be made case by case by installer.

Compressor Motor Phase Sequencing

Always verify that proper rotation of the chiller compressor is established before the machine is started. Proper motor rotation requires confirmation of the electrical phase sequence of the power supply. The motor is internally connected for clockwise rotation with the incoming power supply phased A, B, C (L1, L2, L3).

To confirm the correct phase sequence (ABC), use a phase meter.

Basically, voltages generated in each phase of a polyphase alternator or circuit are called phase voltages. In a 3-phase circuit, 3 sine wave voltages are generated, differing in phase by 120 electrical degrees. The order in which the 3 voltages of a 3-phase system succeed one another is called phase sequence or phase rotation. This is determined by the direction of rotation of the alternator. When rotation is clockwise, phase sequence is usually called "ABC."

This direction may be reversed outside the alternator by interchanging any two of the line wires. It is this possible interchange of wiring that makes a phase sequence indicator necessary if the operator is to quickly determine the phase rotation of the motor.

Module and Control Panel Connectors

All connectors can be unplugged or the wires can be removed. If an entire plug is removed, make sure the plug and the associated jack are marked for proper location identification during reinstallation.

All electrical drawings, schematics and control panel layout are included in the documentation package sent with the chiller.



Installation - Electrical

Interconnecting Wiring (Field Wiring Required)

Important: Do not turn chiller on or off using the chilled water pump interlocks.

When making field connections, refer to the appropriate field layout, wiring, schematics and controls diagrams that ship with the unit. Whenever a contact closure (binary output) is referenced, the electrical rating is:

At 120 VAC	7.2 amp resistive 2.88 amp pilot duty 250 W, 7.2 FLA, 43.2 LRA
At 240 VAC	5.0 amp resistive 2.0 amp pilot duty 250 W, 3.6 FLA, 21.3 LRA

Whenever a dry contact input (binary input) is referenced, the electrical rating is 24 VDC, 12 mA.

Whenever a control voltage contact input (binary input) is referenced, the electrical rating is 120 VAC, 5mA.

Note: Asterisked connections require the user to provide an external source of power. The 115V control power transformer is not sized for additional load.

Chilled Water Pump Control

Tracer UC800 has a evaporator water pump output relay that closes when the chiller is given a signal to go into the Auto mode of operation from any source. The contact is opened to turn off the pump in the event of most machine level diagnostics to prevent the build up of pump heat. To protect against the build-up of pump heat for those diagnostics that do not stop and/or start the pump and to protect against the condition of a bad flow switch, the pump shall always be stopped when refrigerant pressure is seen to be close to heat exchanger design pressure.

Chilled Water Flow Interlock

Tracer UC800 has an input that will accept a contact closure from a proof-of-flow device such as a flow witch. The flow switch is to be wired in series with the chilled water pump starter's auxiliary contacts. When this input does not prove flow within 20 minutes relative to transition from Stop to Auto modes of the chiller, or if the flow is lost while the chiller is in the Auto mode of operation, the chiller will be inhibited from running by a non-latching diagnostic. The flow switch input shall be filtered to allow for momentary openings and closings of the switch due to turbulent water flow. This is accomplished with a 6 seconds filtering time. The sensing voltage for the condenser water flow switch is 115/240 VAC

IMPORTANT! DO NOT cycle the chiller through starting and stopping the chilled water pump. This could cause the compressor to shut down fully loaded. Use the external stop/start input to cycle the chiller.

Installation - Electrical

Condenser Water Pump Control

Tracer UC800 provides a contact closure output to start and stop the condenser water pump. It will allow to run the condenser pump after compressor stop to avoid risk of freezing due to refrigerant migration from evaporator. Condenser Water Pump Prestart time has been added to help with cold condenser water problems. In very cold outdoor ambient, the cooling device's sump would reach the chiller some time after the low system differential pressure protection had run through its ignore time, and result in an immediate shutdown and latching diagnostic. By simply starting the pump earlier, and allowing mixing of the warmer indoor loop with the cooling device's sump, this problem can be avoided.

Condenser Water Flow Interlock

The Tracer UC800 shall accept an isolated contact closure input from a customer installed proof-of-flow device such as a flow switch and customer provided pump starter auxiliary contact for interlocking with condenser water flow.

The input shall be filtered to allow momentary openings and closings of the switch due to turbulent water flow, etc. This shall be accomplished with a 6 seconds filtering time. The sensing voltage for the condenser water flow switch is 115/240 VAC.

On a call for cooling after the restart inhibit timer has timed out, the Tracer UC800 shall energize the condenser water pump relay and then check the condenser water flow switch and pump starter interlock input for flow confirmation.

Startup of the compressor will not be allowed until flow has proven. If flow is not initially established within 1200 seconds (20 minutes) of the condenser pump relay energizing, an automatically resetting diagnostic "Condenser Water Flow Overdue" shall be generated which terminates the prestart mode and de-energizes the condenser water pump relay. This diagnostic is automatically reset if flow is established at any later time.

Note: This diagnostic would never automatically reset if Tracer UC800 was in control of the condenser pump through its condenser pump relay since it is commanded off at the time of the diagnostic. It could however reset

and allow normal chiller operation if the pump was controlled from some external source.

Programmable Relays (Alarm and Status)

Tracer UC800 provides a flexible alarm or chiller status indication to a remote location through a hard wired interface to a dry contact closure. 4 relays are available for this function as a Quad Relay Output LLID and a second quad relay board can be field mounted if more than 4 different alarm/status are needed (refer to your local Trane service). The events/states that can be assigned to the programmable relays are listed in the following table.



Installation - Electrical

The Tracer UC800 Service Tool (TU) is used to install and assign any of the above listed events or status to each of the 4 relays. The default assignments for the 4 available relays are listed below.

LLID Name	LLID Software		
	Relay Designation	Output Name	Default
Operating Status Programmable Relays	Relay 0	Status Relay 1, J2-1,2,3	Evaporator Freeze Avoidance Request
	Relay 1	Status Relay 2, J2-4,5,6	Condenser Freeze Avoidance Request
	Relay 2	Status Relay 3, J2-7,8,9	Compressor Running
	Relay 3	Status Relay 4, J2-10,11,12	Latching Alarm

Latching input

The Tracer UC800 provides auxiliary control for a customer specified/installed latching trip out. When this customer-furnished remote contact is provided, the chiller will run normally when the contact is closed. When the contact opens, the unit will trip off on a manually resettable diagnostic. This condition requires manual reset at the chiller switch on the front of the control panel.

External Auto/Stop

If the unit requires the external Auto/Stop function, the installer must provide leads from the remote contacts to the proper terminals of the LLID on the control panel. The chiller will run normally when the contacts are closed. When the contact opens, the compressor(s), if operating, will go to the RUN : UNLOAD operating mode and cycle off. Unit operation will be inhibited. Re-closure of the contacts will permit the unit to automatically return to normal operation.

NOTE: A "panic" stop (similar to "emergency" stop) can be manually commanded by pressing the STOP button twice in a row, the chiller will immediately shut down, but without creating a latching diagnostic.

Soft Loading

Soft loading will prevent the chiller from going to full capacity during the pull-down period. The Tracer UC800 control system has two soft loading algorithms running all of the time. They are capacity control soft loading and current limit soft loading. These algorithms introduce the use of a Filtered Chilled Water Setpoint and a Filtered Current Limit Setpoint. After the compressor has been started, the starting point of the filtered chilled water setpoint is initialized to the value of the Evap Leaving Water Temperature. The filtered current limit setpoint is initialized to the value of the Current Limit Softload Starting Percent. These filtered setpoints allow for a stable pull-down that is user adjustable in duration. They also eliminate sudden transients due to setpoint changes during normal chiller operation.

3 settings are used to describe the behaviour of soft loading. The setup for soft loading can be done using TU.

- Capacity Control SoftloadTime: This setting controls the time constant of the Filtered Chilled Water Setpoint. It is settable between 0 and 120 min.
- Current Limit Control SoftloadTime: This Setting controls the time constant of the Filtered Current Limit Setpoint. It is settable between 0 and 120 minutes.
- Current Limit Softload Starting %: This setting controls the starting point of the Filtered Current Limit Setpoint. It is adjustable from 40 to 100% RLA.

Installation - Electrical

LonTalk Communication Interface - Optional

Tracer UC800 provides an optional LonTalk Communication Interface (LCI-C) between the chiller and a BAS. An LCI-C LLID shall be used to provide "gateway" functionality between the LonTalk protocol and the chiller.

Bacnet Communication Interface - Optional

Tracer UC800 provides an optional Bacnet communication interface between the chiller and a BAS. Bacnet communication capability is fully integrated on UC800. For further information see Integration Guide.

Modbus Communication Interface - Optional

Tracer UC800 provides an optional Modbus communication Interface between the chiller and a BAS. Modbus communication capability is fully integrated on UC800. For further information see the Integration guide.

Ice Making Contact - Optional

Tracer UC800 accepts a contact closure input to initiate Ice Building. When in the ice building mode, the compressor will be fully loaded (not given a low setpoint) and will continue to operate until the ice contacts open or the return water temperature reaches the Ice Termination Setpoint. If terminated on return setpoint, Tracer UC800 will not allow the chiller to restart until the ice making contact is opened.

Ice Machine Control - Optional

Tracer UC800 provides an output contact closure that can be used as a signal to the system that ice building is in operation. This relay will be closed when ice building is in progress and open when ice building has been terminated by either Tracer UC800 or the remote interlock. It is used to signal the system changes required to convert to and from ice making.

External Chilled Water Setpoint - Optional

Tracer UC800 will accept either a 2-10 VDC or a 4-20 mA input signal, to adjust the chilled water setpoint from a remote location.

Auxiliary Chilled/Hot Setpoint Contact - Optional

Tracer UC800 accepts a contact closure input to switch from BAS/External/Front Panel setpoint to a customer defined auxiliary setpoint. By default, chilled water auxiliary setpoint is set to 9°C and hot water auxiliary setpoint is set to 33°C.

External Demand Limit Setpoint - Optional

Tracer UC800 will accept either a 2-10VDC or a 4-20mA input signal to adjust the demand limit setpoint from a remote location.

Percent Condenser Pressure Output - Optional

Tracer UC800 provides a 2-10 VDC analog output to indicate condenser pressure in percent of software High Pressure Cutout (soft HPC).

Percent HPC = (Lowest Condenser Pressure of all running circuits (abs) / Soft HPC (abs)) * 100.

Refrigerant Differential Pressure Indication - Optional

Tracer UC800 provides a 2-10 VDC analog output to indicate refrigerant differential pressure with the endpoints customer defined.

Refrigerant Differential Pressure = Lowest of (condenser refrigerant pressure cktx - evaporator refrigerant pressure cktx).

Unit Percent RLA Output - Optional

Tracer UC800 provides a 0-10 Vdc analog output to indicate unit %RLA. 2 to 10 Vdc corresponds to 0 to 130% RLA.



Operating Principles Mechanical

This section contains an overview of the operation and maintenance of RTHF chillers equipped with microcomputer-based control systems. It describes the overall operating principles of the RTHF. Following the section is information regarding specific operating instructions, detailed descriptions of the unit controls and options and maintenance procedures that must be performed regularly to keep the unit in top condition. Diagnostic information is provided to allow the operator to identify system malfunctions.

Note: To ensure proper diagnosis and repair, contact a qualified service organization if a problem should occur.

General

The RTHF units are multi compressors, dual circuit, water-cooled liquid chillers. These units are equipped with unit mounted starter/control panels. The basic components of RTHF unit are:

- Unit-mounted panel containing starter and Tracer UC800 controller and Input/output LLIDS
- Helical-rotary compressor
- Evaporator
- Electronic expansion valve
- Water-cooled condenser with integral subcooler
- Oil supply system
- Oil cooler (application dependent)
- Related interconnecting piping
- AFD (Adaptive Frequency Drive) on HSE versions

Refrigeration (Cooling) Cycle

The refrigeration cycle of the RTHF chiller is conceptually similar to that of other Trane chiller products. It makes use of a shell-and-tube evaporator design with refrigerant evaporating on the shell side and water flowing inside tubes having enhanced surfaces.

The compressor is a twin-rotor helical-rotary type. It uses a suction gas-cooled motor that operates at lower motor temperatures under continuous full- and part-load operating conditions. An oil management system provides oil-free refrigerant to the shells to maximize heat transfer performance, while providing lubrication and rotor sealing to the compressor. The lubrication system ensures long compressor life and contributes to quiet operation.

Condensing is accomplished in a shell-and-tube heat exchanger where refrigerant is condensed on the shell side and water flows internally in the tubes.

Refrigerant is metered through the flow system using an electronic expansion valve that maximizes chiller efficiency at part load.

A unit-mounted starter (Wye delta on SE, HE, PE Versions or AFD on HSE versions) and control panel is provided on every chiller. Microprocessor-based unit control modules (Tracer UC800) provide for accurate chilled water control as well as monitoring, protection and adaptive limit functions. The "adaptive" nature of the controls intelligently prevents the chiller from operating outside of its limits, or compensates for unusual operating conditions, while keeping the chiller running rather than simply tripping due to a safety concern. When problems do occur, diagnostic messages assist the operator in troubleshooting.

Operating Principles Mechanical

Cycle Description

The refrigeration cycle for the RTHF chiller can be described using the pressure-enthalpy diagram shown in Figure 8. Key State Points are indicated on the figure and are referenced in the discussion following. Typical schematics of the system showing the refrigerant flow loop as well as the lubricant flow loop is shown in Figure 9.

Evaporation of refrigerant occurs in the evaporator that maximizes the heat transfer performance of the heat exchanger while minimizing the amount of refrigerant charge required. A metered amount of refrigerant liquid enters a distribution system in the evaporator shell and is then distributed to the tubes in the evaporator tube bundle.

The refrigerant vaporizes as it cools the water flowing through the evaporator tubes. Refrigerant vapor leaves the evaporator as saturated vapor (State Point 1).

The refrigerant vapor generated in the evaporator flows to the suction end of the compressor where it enters the motor compartment of the suction-gas-cooled motor. The refrigerant flows across the motor, providing the necessary cooling, then enters the compression chamber. Refrigerant is compressed in the compressor to discharge pressure conditions. Simultaneously, lubricant is injected into the compressor for two purposes: (1) to lubricate the rolling element bearings, and (2) to seal the very small clearances between the compressor's twin rotors.

Immediately following the compression process the lubricant and refrigerant are effectively divided using an oil separator. The oil-free refrigerant vapor enters the condenser at State Point 2. The lubrication and oil management issues are discussed in more detail in the compressor description and oil management sections that follow.

Baffles within the condenser shell distribute the compressed refrigerant vapor evenly across the condenser tube bundle. Cooling device water, circulating through the condenser tubes, absorbs heat from this refrigerant and condenses it.

As the refrigerant leaves the bottom of the condenser (State Point 3), it enters an integral subcooler where it is subcooled before traveling to the electronic expansion valve (State Point 4). The pressure drop created by the expansion process vaporizes a portion of the liquid refrigerant. The resulting mixture of liquid and gaseous refrigerant then enters the Evaporator Distribution system (State Point 5). The flash gas from the expansion process is internally routed to the compressor suction, and while the liquid refrigerant is distributed over the tube bundle in the evaporator.

The RTHF chiller maximizes the evaporator heat transfer performance while minimizing refrigerant charge requirements. This is accomplished by metering the liquid refrigerant flow to the evaporator's distribution system using the electronic expansion valve.

A liquid level measurement device monitors liquid level in the condenser and provides feedback information to the Tracer UC800 unit controller, which commands the electronic expansion valve to reposition when necessary.

Figure 8 – Pressure /Enthalpy Curve

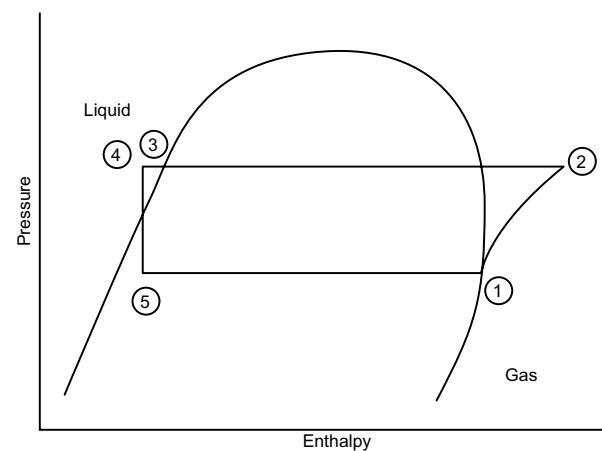

Operating Principles Mechanical



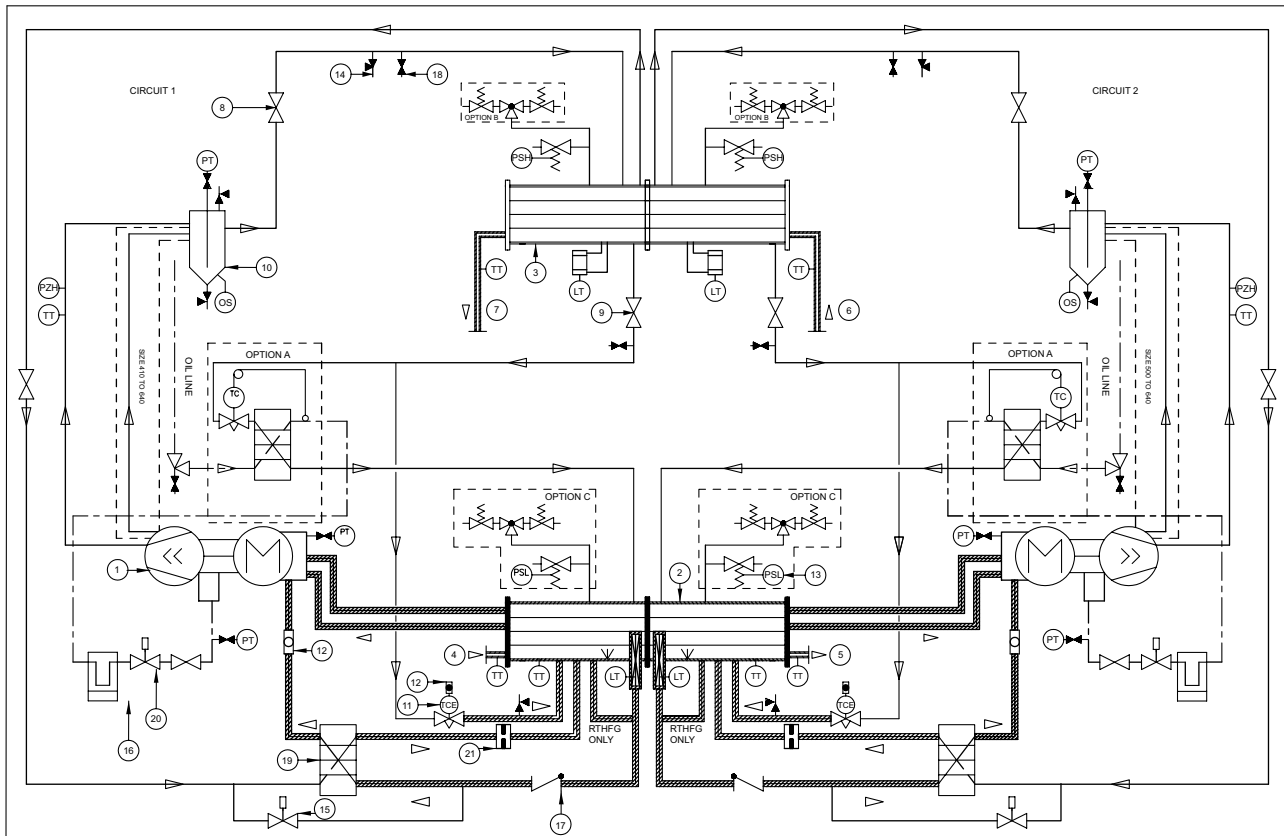

Refrigerant flow diagram

Refrigerant flow diagram for RTHF unit is supplied with drawing package joint with unit order.

Figure 9 – Example of typical refrigerant flow diagram for RTHF



- 1 = Screw compressor
- 2 = Evaporator
- 3 = Water cooled condenser
- 4 = Evaporator water inlet connection
- 5 = Evaporator water outlet connection
- 6 = Condenser water inlet connection
- 7 = Condenser water outlet connection
- 8 = Discharge service valve
- 9 = Liquid shut off valve
- 10 = Oil separator
- 11 = Electronic expansion valve
- 12 = Sight glass
- 13 = Relief valve
- 14 = Service valve
- 15 = Solenoid valve
- 16 = Oil filter
- 17 = Check valve
- 18 = Schraeder valve
- 19 = BPHE oil return
- 20 = Master oil solenoid
- 21 = Restrictor

	Refrigerant line
	Oil line
	Chilled heated water line
	Insulation

- PT = Pressure transducer
- PSH = High pressure relief valve
- PSL = Low pressure relief valve
- PZH = High pressure switch
- TT = Temperature sensor
- TCE = Electronic expansion valve
- TC = Thermostatic expansion valve
- OS = Optical sensor
- LT = Liquid level sensor
- Option A = Auxiliary oil cooler
- Option B = Single or dual relief valve for condenser
- Option C = Single or dual relief valve for exaporator

Operating Principles Mechanical

Compressors

The compressor used by the RTHF chiller consists of 3 distinct sections: the motor, the rotors and the bearing housing.

Compressor Motor

A two-pole, hermetic, squirrel-cage induction motor directly drives the compressor rotors. The motor is cooled by suction vapor drawn from the evaporator and entering the end of the motor housing through the suction line.

Compressor Rotors

Each RTHF chiller uses a semi-hermetic, direct-drive Helical-Rotary type compressor. Excluding the bearings, each compressor has only 3 moving parts:

2 rotors - "male" and "female" - provide compression, and a slide valve that controls capacity. The male rotor is attached to, and driven by, the motor, and the female rotor is, in turn, driven by the male rotor. Separately housed bearing sets are provided at each end of both rotors. For RTHF, the slide valve is located below and moves along the rotors.

The helical-rotary compressor is a positive displacement device. Refrigerant from the evaporator is drawn into the suction opening at the end of the motor section. The gas is drawn through a suction strainer across the motor, cooling it, and then into the rotor section. It is then compressed and discharged directly into the discharge plenum for RTHF.

There is no physical contact between the rotors and compressor housing. Oil is injected through adequate ports, coating both rotors and the compressor housing interior. Although this oil does provide rotor lubrication, its primary purpose is to seal the clearance spaces between the rotors and compressor housing. A positive seal between these internal parts enhances compressor efficiency by limiting leakage between the high pressure and low pressure cavities.

Capacity control is accomplished by means of a slide valve assembly for RTHF.

Slide Valve Movement on versions without AFD

Movement of the slide valve/piston determines rotor coverage which regulates compressor capacity. On compressor shutdown, the unload solenoid valve is energized and leads to fully-unloaded position, so the unit always starts fully unloaded.

Slide Valve movement for HSE version

Slide valve operates in HSE versions coordinated with AFD. Tracer UC800 algorithm controls the compressor capacity with higher slide valve capacity and lower AFD frequency to get higher efficiency

This loading/unloading schema is a general figure, it could be different in case of sudden modifications of the operating data. Also it has not to be considered as a starting/stopping mode.

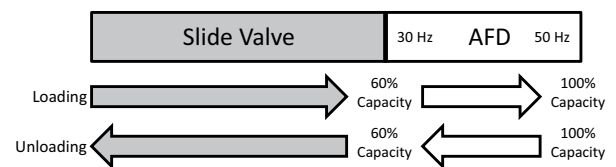

Slide valve movement on version XSE

The slide valve can move back and from high volume index position (optimized for high pressure ratio) to low volume index position (optimized for low pressure ratio) depending on the chiller operating conditions. The slide valve position is managed by the Tracer UC800 algorithm to achieve the best efficiency.

Operating Principles Mechanical

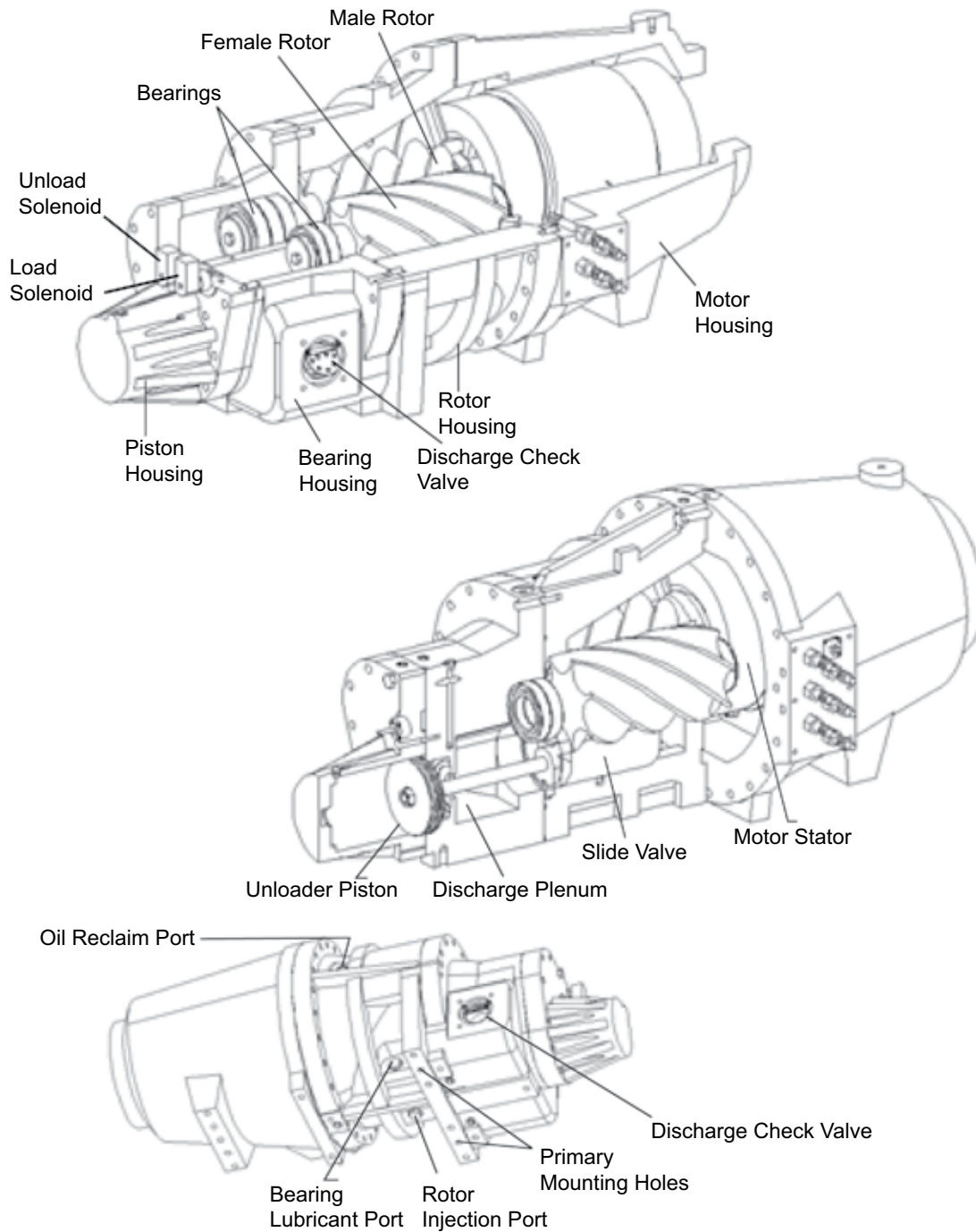

Note:

For XSE range Compressors:

Unload Solenoid = High Vi solenoid

Load Solenoid = Low Vi solenoid

Operating Principles Mechanical

Oil Management System

Oil Separator

The oil separator consists of a vertical tube, joined at the top by the refrigerant discharge line from the compressor. This causes the refrigerant to swirl in the tube and throws the oil to the outside, where it collects on the walls and flows to the bottom. The compressed refrigerant vapor, stripped of oil droplets, exits out the top of the oil separator and is discharged into the condenser.

Oil that collects in the bottom of the oil separator at condensing pressure during compressor operation; therefore, oil is constantly moving to lower pressure areas.

Oil Flow Protection

Oil flow and quality is proven through a combination of a number of sensors, most notably a pressure transducer and the optical oil level sensor.

If for any reason oil flow is obstructed because of a plugged oil filter, closed service valve, faulty master solenoid, or other source, the oil pressure transducer will read an excessively high pressure drop in the oil system (relative to the total system pressure) and shut down the chiller.

Likewise, the optical oil level sensor can detect the lack of oil in the primary oil system (which could result from improper oil charging after servicing, or oil logging in other parts of the system). The sensor will prevent the compressor from starting or running unless an adequate volume of oil is present. The combination of these two devices, as well as diagnostics associated with extended low system differential pressure and low superheat conditions, can protect the compressor from damage due to severe conditions, component failures, or improper operation.

To ensure the required system differential pressure is adequate to move oil to the compressor, the Tracer UC800 attempts to both control a minimum system differential pressure as well as monitor it. Based on readings from pressure transducers in both the evaporator and condenser. Once the minimum is met, the EXV will return to normal liquid level control (see the paragraph on "Cycle Description"). If the differential is significantly lower than required, the unit will trip and initiate appropriate diagnostics and would enforce a compressor "cool down" period. To ensure proper lubrication and minimize refrigerant condensation in the oil sump, heaters are mounted on the bottom of the oil sump. An auxiliary contact of the compressor starter, energizes these heaters during the compressor off cycle to maintain a proper elevation of the oil temperature. The heater element is continuously energized while the compressor is off and does not cycle on temperature.

Oil Filter

All Series R chillers are equipped with replaceable-element oil filters. Each removes any impurities that could foul the compressor internal oil supply galleries. This also prevents excessive wear of compressor rotor and bearing surfaces and promotes long bearing life. Refer to maintenance section for recommended filter element replacement intervals.

Compressor Rotor Oil Supply

Oil flowing through this circuit enters the compressor rotor housing. From there it is injected along the rotors to seal clearance spaces around the rotors and lubricate the contact line between the male and female rotors.

Lubricant Recovery

Despite the high efficiency of the oil separators, a small percentage of oil will get past them, move through the condenser, and eventually end up in the evaporator. This oil must be recovered and returned to the oil separator. The function of oil return is accomplished by passive thermosiphon system: a portion of liquid refrigerant + oil of the evaporator goes continuously through a brazed plate heat exchanger to be vaporized by a small amount of heat coming from the condenser. Then this refrigerant in gas state is re-injected to compressor suction line with the oil, carried by thermosiphon effect.

Oil Cooler

The oil cooler is a brazed plate heat exchanger located near the oil filter. It is designed to transfer approximately 3.5 kW of heat from the oil to the suction side of the system. Subcooled liquid is the cooling source. The oil cooler is required on units running at high condensing or low suction temperatures. The high discharge temperatures in these applications increase oil temperatures above the recommended limits for adequate lubrication and reduce the viscosity of the oil.

Typical Operating map

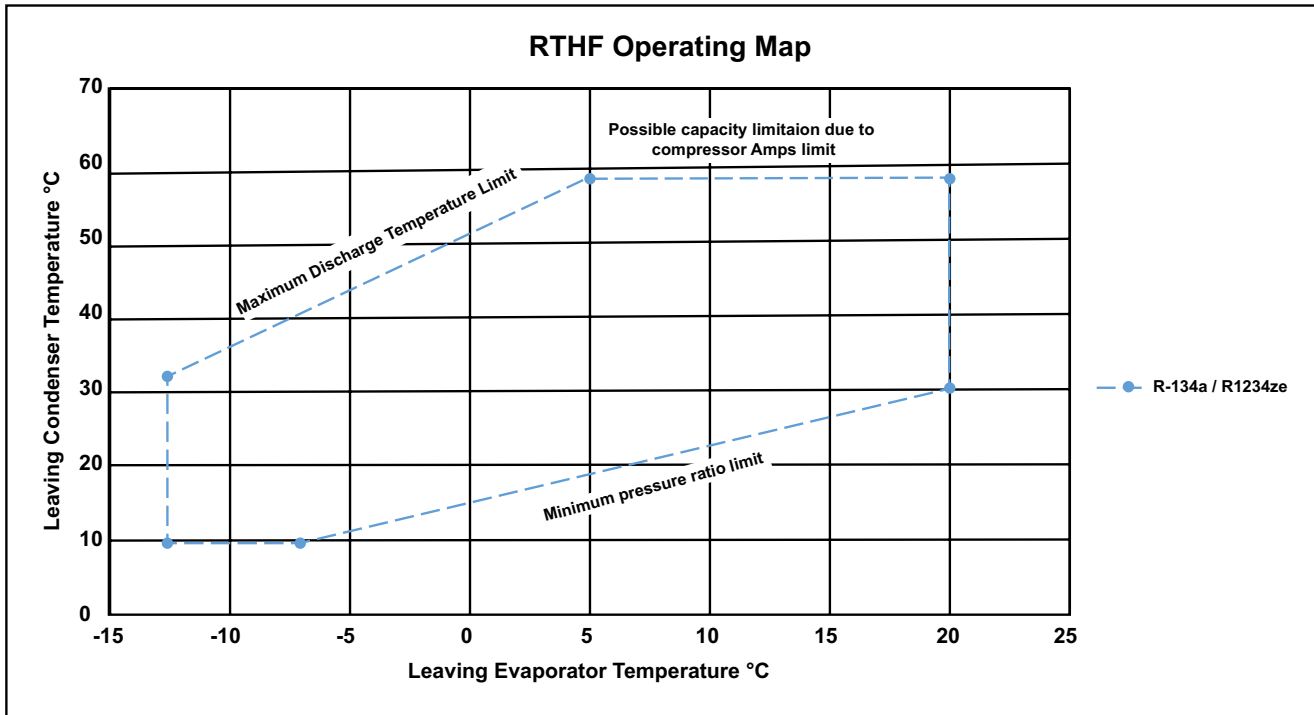

RTHF is not built to operate continuously unloaded due to motor cooling concerns. Doing so could lead to latching trips on motor and compressor protection devices and could not be claimed to TRANE.

Note:

- For part load conditions, operating map will change. Contact Trane representative for more details.
- For the RTHF XSE range, the minimum part load that the chiller can achieve depends on the operating conditions. For the additional information, contact Trane sales organization representative

Controls/Tracer TD7 Operator Interface

Controls Overview

RTHF units use the following control/interface components:

- Tracer™ UC800 Controller
- TracerTD7 Operator Interface

Communication Interfaces

There are four connections on the UC800 that support the communication interface. See TracerTD7 User Guide RLC-SVU007 to locate the following ports: “Wiring and Ports Description” section.

- BACnet MS/TP
- BACnet IP (from BACnet MS/TP)
- Modbus Slave
- LonTalk using LCI-C (from the IPC3 bus)

See chiller User Guide for information on communication interface.

Tracer TD7 Operator Interface

Operator Interface

Information is tailored to operators, service technicians and owners. When operating a chiller, there is specific information you need on a day-to-day basis, like setpoints, limits, diagnostic information, and reports. Day-to-day operational information is presented at the display. Logically organized groups of information-chiller mode of operation, active diagnostics, settings and reports put information conveniently at your fingertips

Tracer™ TU

The TD7 operator interface allows for daily operation tasks and setpoint changes. However to adequately service RTHF chillers, Tracer™ TU service tool is required (Non-Trane personnel, contact your local Trane office for software purchase information). Tracer TU adds a level of sophistication that improves service technician effectiveness and minimizes chiller downtime. This portable PC-based service-tool software supports service and maintenance tasks.



Pre-Start Checkout

CAUTION

Proper Water Treatment!

The use of untreated or improperly treated water may result in scaling, erosion, corrosion, algae or slime. It is recommended that the services of a qualified water treatment specialist be engaged to determine what water treatment, if any, is required. Trane assumes no responsibility for equipment failures which result from untreated or improperly treated water, or saline or brackish water.

At 65°C condensing leaving water temperature and above, it is mandatory to have condenser equipped with CuNi tubes.

Installation Checklist

Complete this checklist as the unit is installed, and verify that all recommended procedures are accomplished before the unit is started. This checklist does not replace the detailed instructions given in the "Installation Mechanical" and "Installation Electrical" sections of this manual. Read both sections completely, to become familiar with the installation procedures, prior beginning the work.

General

When installation is complete, before starting the unit, the following prestart procedures must be reviewed and verified:

1. Inspect all wiring connections in the compressor power circuits (disconnects, terminal block, contactors, compressor junction box terminals and so forth) to ensure they are clean and tight.
2. Open all refrigerant valves in the discharge, liquid, and oil return lines.
3. Check the power-supply voltage to the unit at the main-power fused-disconnect switch. Voltage must be within the voltage use range and also stamped on the unit nameplate. Voltage fluctuation must not exceed 10%. Voltage imbalance must not exceed 2%.
4. Check the unit power phasing L1-L2-L3 in the starter to ensure that it has been installed in a "A-B-C" phase sequence.
5. Fill the evaporator and condenser water circuit. Vent the system while it is being filled. Open the vents on the top of the evaporator water and condenser boxes while filling and close when filling is completed.
6. Close the disconnect switch(es) that supplies power to the chilled-water pump starter.
7. Start the evaporator and condenser water pump to begin circulation of the water. Inspect all piping for leakage and make any necessary repairs.
8. With water circulating through the system, adjust the water flow and check the water pressure drop through the evaporator and condenser.
9. Adjust the chilled-water flow switch for proper operation
10. Reapply power to complete the procedures.
11. Prove all Interlock and Interconnecting Wiring Interlock and External as described in the Electrical Installation section.
12. Check and set, as required, all UC800TD7 menu items.
13. Stop the evaporator and condenser water pump.
14. Energize the compressor and oil separator heaters 24 hours, prior to unit start up.

Unit Voltage Power Supply

Unit voltage must meet the criteria given in the installation Electrical Section. Measure each lead of the supply voltage at the main power disconnect switch for the unit. If the measured voltage on any lead is not within the specified range, notify the supplier of the power and correct the situation before operating the unit.

Unit Voltage Imbalance

Excessive voltage imbalance between the phases of a three-phase system can cause motors to overheat and eventually fail. The maximum allowable unbalance is 2%. Voltage imbalance is determined using the following calculations:

$$\% \text{ Imbalance} = [(V_x - V_{ave}) \times 100 / V_{ave}]$$

$$V_{ave} = (V_1 + V_2 + V_3) / 3$$

V_x = phase with greatest difference from V_{ave} (without regard to the sign)

Unit Voltage Phasing

Pre-Start Checkout

Unit Voltage Phasing

It is important that proper rotation of the compressors be established before the unit is started. Proper motor rotation requires confirmation of the electrical phase sequence of the power supply. The motor is internally connected for clockwise rotation with the incoming power supply phases A-B-C.

When rotation is clockwise, the phase sequence is usually called "ABC"; when counterclockwise "CBA" This direction may be reversed by interchanging any two of the line wires.

1. Stop the unit from TD7/UC800.
2. Open the electrical disconnect or circuit protection switch that provides line power to the line power terminal block(s) in the starter panel (or to the unit mounted disconnect).
3. Connect the phase-sequence indicator leads to the line power terminal block as follows:

Phase Sequence Lead	Terminal
Phase A	L1
Phase B	L2
Phase C	L3

4. Turn power on by closing the unit supply-power fused-disconnect switch.
5. Read the phase sequence on the indicator. The ABC LED of the phase indicator will glow.

WARNING! It is imperative that L1, L2, and L3 in the starter be connected in the A-BC phase sequence to prevent equipment damage due to reverse rotation.

WARNING! To prevent injury or death due to electrocution, take extreme care when performing service procedures with electrical power energized.

CAUTION! Do not interchange any load leads that are from the unit contactors or the motor terminals. Doing so may damage the equipment.

Water System Flow Rates

Establish a balanced chilled-water flow through the evaporator. The flow rates should be between the minimum and maximum values given on the pressure drop curves.

Water System Pressure Drop

Measure the water-pressure drop through the evaporator on the field installed pressure taps on the system water piping. Use the same gauge for each measurement. Do not include valves, strainers, or fittings in the pressure drop readings.



Unit Start-up

Daily Unit Start Up

The timeline for the sequence of operation begins with a power-up of the main power to the chiller. The sequence assumes 2 circuits, RTHF water cooled chiller with no diagnostics or malfunctioning components. External events such as the operator placing the chiller in AUTO or STOP, chilled water flow through the evaporator, and application of load to the chilled water loop causing loop water-temperature increases, are depicted and the chiller responses to those events are shown, with appropriate delays noted. The effects of diagnostics, and other external interlocks other than evaporator water-flow proving, are not considered.

Note: Unless the UC800TD7 and building automation system are controlling the chilled-water pump, the manual unit start sequence is as follows. Operator actions are noted.

General

If the present checkout, as discussed above, has been completed, the unit is ready to start.

1. Press the STOP key on the TD7 display.
2. As necessary, adjust the set point values on the TD7 menus using TracerTU.
3. Close the fused-disconnect switch for the chilled water pump. Energize the pump(s) to start water circulation
4. Check the service valves on the discharge line, suction line, oil line, and liquid line for each circuit. These valves must be open (back seated) before starting the compressors.
5. Verify that chilled-water pump runs for at least one minute after the chiller is commanded to stop (for normal chilled-water systems).
6. Press the AUTO key. If the chiller control calls for cooling, and all safety interlocks are closed, the unit will start. The compressor(s) will load and unload in response to the leaving chilled – water temperature;

After the system has been operating for approximately 30 minutes and has become stabilized, complete the remaining start up procedures, as follows:

1. Check the evaporator refrigerant pressure and the condenser refrigerant pressure under Refrigerant Report on the TD7.
2. Check the EXV sight glasses after enough time has elapsed to stabilize the chiller. The refrigerant flow through the sight glasses should be clear. Bubbles in the refrigerant indicate either low refrigerant charge or excessive pressure drop in the liquid line, or an expansion valve that is stuck open. A restriction in the line can sometimes be identified by a noticeable temperature differential between the two sides of the restriction. Frost will often form on the line at this point. Proper refrigerant charges are shown in the General Information Section;
3. Measure the system discharge superheat.
4. Clean the air filter located on the door of the control panel of AFD when required.

Seasonal Unit Startup Procedure

1. Close all valves and reinstall the drain plugs in the evaporator and condenser.
2. Service the auxiliary equipment according to the startup and maintenance instructions provided by the respective equipment manufacturers.
3. Close the vents in the evaporator and condenser water circuits.
4. Open all the valves in the evaporator and condenser water circuits.
5. Open all refrigerant valves.
6. If the evaporator and condenser were previously drained, vent and fill the evaporator and condenser water circuit. When all air is removed from the system (including each pass), install the vent plugs in the evaporator and condenser water boxes.
7. Verify periodically water characteristics as it is a key element for heat exchanger reliability.
8. Check the adjustment and operation of each safety and operating control.
9. Close all disconnect switches.
10. Refer to the sequence for daily unit start up for the remainder of the seasonal start up.

CAUTION! Ensure that the compressor and oil separator heaters have been operating for a minimum of 24 hours before starting. Failure to do so may result in equipment damage.

System Restart after Extended Shutdown

1. Verify that the liquid-line service valves, oil line, compressor discharge service valves, and optional suction service valves are open (back seated).
2. Check the oil separator oil level (see Maintenance procedures section).
3. Fill the evaporator and condenser water circuit. Vent the system while it is being filled. Open the vent on the top of the evaporator and condenser while filling, and close it when filling is completed.
4. Close the fused-disconnect switches that provide power to the water pump.
5. Start the evaporator and condenser water pump and, while water is circulating, inspect all piping for leakage. Make any necessary repairs before starting the unit.
6. While the water is circulating, adjust the water flow and check the water pressure drops through the evaporator and condenser. Refer to “water-system flow rates” and “water-system pressure drop”.
7. Adjust the flow switch on the evaporator and condenser piping for proper operation.
8. Stop the water pumps. The unit is now ready for startup as described “Startup procedures.”

CAUTION! To prevent damage to the compressor, ensure that all refrigerant valves are open before starting the unit. Do not use untreated or improperly treated water. Equipment damage may occur.

Ensure that the compressor and oil separator heaters have been operating for a minimum of 24 hours before starting. Failure to do so may result in equipment damage.

Periodic Maintenance

Overview

This section describes preventative maintenance procedures and intervals for the Series R unit. Use a periodic maintenance program to ensure optimal performance and efficiency of the units. An important aspect of the chiller maintenance program is the regular completion of the "Operating Log". When filled out properly the completed logs can be reviewed to identify any developing trends in the chiller's operating conditions.

Weekly Maintenance and Checks

After the unit has operated for approximately 30 minutes and the system has stabilized, check the operating conditions and complete the procedures below:

- Log the chiller.
- Check evaporator and condenser pressures with gauges and compare to the reading on the Clear Language Display. Pressure readings should fall within the following ranges specified in the Operating Conditions.

Table 8– Operating Conditions at Full Load R134a

Description	Condition
Evaporator pressure	3.5 - 3.8 bar
Condensing pressure	8.6 - 10.2 bar
Discharge superheat	9-13°C
Subcooling	3 - 6°C
EXV percent open	30 - 65% open in Auto mode

Table 9– Operating Conditions at Full Load R1234ze

Description	Condition
Evaporator pressure	2.5-2.8 bar
Condensing pressure	6.6-8.2 bar
Discharge superheat	4-8°C
Subcooling	3 - 6°C
EXV percent open	25-60 %

All conditions stated above are based on the unit running fully loaded, running at conditions indicated above. If full load conditions can not be met, refer to note below to trim the refrigerant charge

Note: Entering condenser water: 30°C and entering evaporator water: 12°C.

NOTE: Optimum condenser pressure is dependent on condenser water temperature, and should equal the saturation pressure of the refrigerant at a temperature 1 to 3°C above that of leaving condenser water at full load.

Monthly Maintenance and Checks

- Review operating log.
- Clean all water strainers in both the chilled and condensing water piping systems.
- Measure the oil filter pressure drop. Replace oil filter if required. Refer to "Service Procedures".
- Measure and log the subcooling and superheat.
- If operating conditions indicate a refrigerant shortage, leak check the unit using soap bubbles.
- Repair all leaks.
- Trim refrigerant charge until the unit operates in the conditions listed in the note below.

Note: condenser water: 30/35°C and evaporator water: 12/7°C.



Periodic Maintenance

Table 10 – Operating Conditions at Minimum Load R134a

Description	Condition
Evaporator approach	* < 1.5 °C (non-glycol applications)
Condensing approach	* < 1.5 °C
Subcooling	1-2°C
EXV percent open	< 30%

* 0.5°C for new unit.

Table 11 – Operating Conditions at Minimum Load R1234ze

Description	Condition
Evaporator approach	* < 1.5 °C (non-glycol applications)
Condensing approach	* < 1.5 °C
Subcooling	1-2°C
EXV percent open	< 30%

Annual Maintenance

WARNING: Hazardous Voltage!

Disconnect all electric power, including remote disconnects before servicing. Follow proper lockout / tagout procedures to ensure the power can not be inadvertently energized. Failure to disconnect power before servicing could result in death or serious injury.

- Shut down the chiller once each year to check the following:
- Perform all weekly and monthly maintenance procedures.
- Check the refrigerant charge and oil level. Refer to "Maintenance Procedures " Routine oil changing is not necessary on a hermetic system.
- Have a qualified laboratory perform an oil analysis to determine system moisture content and acid level.
- For units delivered with variable frequency drives, check and clean up the heat sink and the air filters

IMPORTANT NOTE: Due to the hygroscopic properties of the POE oil, all oil must be stored in metal containers. The oil will absorb water if stored in a plastic container.

- Check the pressure drop across the oil filter. Refer to "Maintenance Procedures "
- Contact a qualified service organization to leak check the chiller, to inspect safety controls, and inspect electrical components for deficiencies.
- Inspect all piping components for leakage and/or damage. Clean out any inline strainers.

- Clean and repaint any areas that show signs of corrosion.
- Test vent piping of all relief valves for presence of refrigerant to detect improperly sealed relief valves. Replace any leaking relief valve.
- Inspect the condenser tubes for fouling; clean if necessary. Refer to "Maintenance Procedures "
- Check to make sure that the crank case heater is working.

Scheduling Other Maintenance

- Use a nondestructive tube test to inspect the condenser and evaporator tubes at 3-year intervals.

NOTE: It may be desirable to perform tube tests on these components at more frequent intervals, depending upon chiller application. This is especially true of critical process equipment.

- Depending on chiller duty, contact a qualified service organization to determine when to conduct a complete examination of the unit to determine the condition of the compressor and internal components.
- Follow national regulation when special prescriptions.

Do not swap R134a by R1234ze without intervention of Trane Service organization for advice on technical changes.

Periodic Maintenance

Contractor Confirmation Check Sheet

This check sheet must be completed by the installing contractor and submitted prior to requesting Trane Service start-up support. The check sheet identifies a list of items that need to be completed prior to actual machine start-up.

Contractor Confirmation Check Sheet	
Addressed to the Trane Service office of:	
Job Name:	Job location:
Model No.:	Sales order No.:
Unit	Cooling water
<input type="checkbox"/> Unit installed	<input type="checkbox"/> Connected to the unit
<input type="checkbox"/> Isolator pads in place	<input type="checkbox"/> Connected to the cooling device
Chilled Water	<input type="checkbox"/> Connected to the pumps
<input type="checkbox"/> Connected to the unit	<input type="checkbox"/> System flushed and then filled
<input type="checkbox"/> Connected to the air handling units	<input type="checkbox"/> Pumps run and air bled
<input type="checkbox"/> Connected to the pumps	<input type="checkbox"/> Strainers cleaned
<input type="checkbox"/> System flushed and then filled	<input type="checkbox"/> Flow switch installed and checked/set
<input type="checkbox"/> Pumps run and air bled	<input type="checkbox"/> Throttling cock installed in leaving water
<input type="checkbox"/> Strainers cleaned	<input type="checkbox"/> Thermometers installed in leaving/entering water
<input type="checkbox"/> Flow switch installed and checked/set	<input type="checkbox"/> Gauges installed in leaving/entering water
<input type="checkbox"/> Throttling cock installed in leaving water	<input type="checkbox"/> Cooling water control operational
<input type="checkbox"/> Thermometers installed in leaving/entering water	<input type="checkbox"/> Water treatment equipment
<input type="checkbox"/> Gauges installed in leaving/entering water	Wiring
	<input type="checkbox"/> Power supply connected and available
	<input type="checkbox"/> External interlock connected
	Load
	<input type="checkbox"/> System can be operated under load condition

We will therefore require your service technician on job by* _____.

Checklist completed by _____.

Date _____.

* Return this completed checklist to your Trane Service office as soon as possible to enable the start-up visit to be scheduled. Be aware that advance notification is required to allow scheduling of the start-up as close to the requested date as possible. Additional time required to complete the start-up and adjustment due to incompleteness of the installation will be invoiced at prevailing rates.



Maintenance Procedures

Cleaning the Condenser

CAUTION: Proper Water Treatment!

The use of untreated or improperly treated water in a RTHF may result in scaling, erosion, corrosion, algae or slime. It is recommended that the services of a qualified water treatment specialist be engaged to determine what water treatment, if any, is required. The manufacturer assumes no responsibility for equipment failures which result from untreated or improperly treated water, saline or brackish water.

At 65°C condensing leaving water temperature and above, it is mandatory to have condenser equipped with CuNi tubes.

Condenser tube fouling is suspect when the “approach” temperature (i.e., the difference between the refrigerant condensing temperature and the leaving condenser water temperature) is higher than predicted. Standard water applications will operate with less than a 5°C approach. If the approach exceeds 5°C and there is no-condensable in the system cleaning the condenser tubes is recommended.

NOTE: Glycol in the water system typically doubles the standard approach.

If the annual condenser tube inspection indicates that the tubes are fouled, 2 cleaning methods can be used to rid the tubes of contaminants. The methods are:

Mechanical Cleaning Procedure

Mechanical tube cleaning this method is used to remove sludge and loose material from smooth-bore condenser tubes.

1. Remove the retaining bolts from the water boxes at each end of the condenser. Use a hoist to lift the water boxes.
2. Work a round nylon or brass bristled brush (attached to a rod) in and out of each of the condenser water tubes to loosen the sludge.
3. Thoroughly flush the condenser water tubes with clean water. (To clean internally enhanced tubes, use a bi-directional brush or consult a qualified service organization for recommendations.)

Chemical Cleaning Procedure

Scale deposits are best removed by chemical means. Consult a qualified water treatment specialist (i.e., one that knows the local water supply chemical/ mineral content) for a recommended cleaning solution suitable for the job. (A standard condenser water circuit is composed solely of copper, cast iron and steel.) Improper chemical cleaning can damage tube walls.

All of the materials used in the external circulation system, the quantity of the solution, the duration of the cleaning period, and any required safety precautions should be approved by the company furnishing the materials or performing the cleaning.

NOTE: Chemical tube cleaning should always be followed by mechanical tube cleaning.

Cleaning the Evaporator

Since the evaporator is typically part of a closed circuit, it does not accumulate appreciable amounts of scale or sludge. However, if cleaning is deemed necessary, use the same cleaning methods described for the condenser tubes.

Compressor Oil

CAUTION: Equipment Damage!

To prevent oil sump heater burnout, open the unit main power disconnect switch before removing oil from the compressor.

Trane Polyolester Oil is the approved oil for the RTHF units. Polyolester oil is extremely hygroscopic meaning it readily attracts moisture. The oil can not be stored in plastic containers due to the hygroscopic properties. As with mineral oil, if water is in the system it will react with the oil to form acids. Use Table 12 to determine the acceptability of the oil. Trane approved oils on non AFD versions is OIL 0048E and OIL 0023E, on HSE version (with AFD) Trane approved oil is OIL00317. The proper charge amounts are given on General data. Note: Use an oil transfer pump to change the oil regardless of chiller pressure.

For R1234ze, approved oil is OIL0066E/OIL0067E.

Maintenance Procedures

Maintenance Procedures

Table 12 - POE Oil Properties

Description	Acceptable Levels
Moisture content	less than 300 ppm
Acid Level (mg KOH/g)	less than 0.5 TAN

Running the chiller at minimum load is the best for the quickest return of oil to the separator and sump. The machine still needs to sit for approximately 30 minutes before the level is taken. At minimum load, the discharge superheat should be highest. The more heat in the oil as it lays in the sump, the more refrigerant will boil off in the sump and leave more concentrated oil. The oil level in the oil sump can be measured to give an indication of the system oil charge. Follow the procedures below to measure the level.

1. Run the unit fully unloaded for approximately 20 minutes.
2. Cycle the compressor off line.

Oil Level Check

Figure 10 – Determining oil level in the oil separator

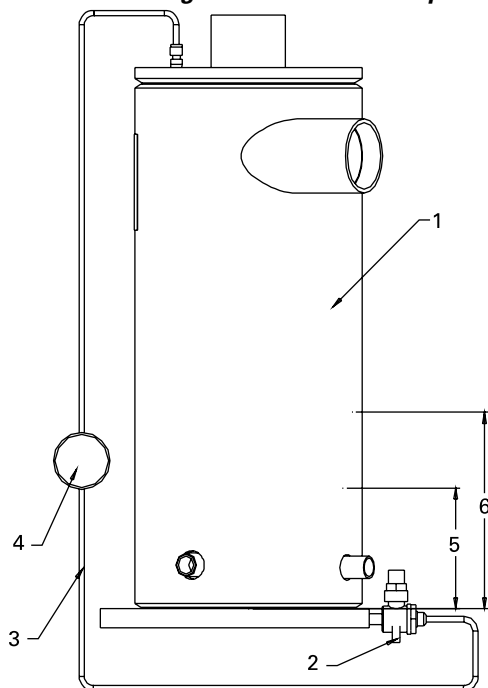

- 1 = Oil separator
- 2 = Valve
- 3 = 1/4" refrigeration hose
- 4 = Sight glass
- 5 = Minimum oil level
- 6 = Maximum oil level

How to measure the oil level:

1. Use the oil drain valve (bottom side) and the service valve on the oil separator (top side). This measurement can be made, when the circuit is not running. Note: the bottom plate of the oil separator is approximately 25 mm thick.
2. The initial oil charge should be approximately at the level in of the above chart. This is the approximate oil and the unit is in vacuum so that there is no refrigerant dissolved in the oil.

After the unit has run for a while, the oil level in the sump can vary greatly. However, if the unit has run at "normal" conditions for a long time, the level should resemble the level in the above chart: Minimum and maximum oil levels should correspond to values shown in below table evaporator approach temperature.

Oil separator size	Compressors type	Min. oil level (mm)	Max. oil level (mm)
12"	"B" type (RTHF)	50 mm	170 mm
14"	"C" type (RTHF)	50 mm	240 mm
16"	"D" type (RTHF)	50 mm	220 mm

The field charging procedure depends on the circumstances that resulted in the need for oil charge.

1. Some services procedures may result in loss of small quantities of oil that must be replaced (oil analysis, compressor filter replacement, re-tubing the evaporator, and so forth).
2. Additionally, some maintenance procedures may result in virtually all the oil being removed (compressor motor burn or total removal of the charge to trouble shoot a unit).
3. Finally, leaks may result in a loss of oil that must be replaced.

Oil charging data.

The oil quantity is written on the nameplate of the unit.

Maintenance Procedures

Removing Compressor Oil

The oil in the compressor oil separator is under a constant positive pressure at ambient temperature. To remove oil, open the service valve located on the bottom of the oil separator and drain the oil into a suitable container using the procedure outlined below:

CAUTION: POE Oil!

Due to the hygroscopic properties of the POE oil, all oil must be stored in metal containers. The oil will absorb water if stored in a plastic container.

Oil should not be removed until the refrigerant is isolated or removed.

Connect a line to the oil sump drain valve.

Open the valve and allow the desired amount of oil to flow into the container and close the charging valve.

Measure the exact amount of oil removed from the unit.

Oil Charging Procedure

It is critical to fill the oil lines feeding the compressor when charging a system with oil. The diagnostic "Loss of oil at the compressor stopped" will be generated if the oil lines are not full on start-up.

To properly charge the system with oil, follow the steps below:

1. Locate the 1/4 " schrader valve between the ball valve and oil filter (or the ball valve and oil cooler, if so equipped) for RTHF
2. Loosely connect oil pump to schrader valve called out in step 1.
3. Operate oil charging pump until oil appears at the charging valve connection; then tighten the connection.

NOTE: To keep air from entering the oil, the charging valve connection must be air-tight.

4. Open the service valve and pump in the required amount of oil.
5. Monitor the "Oil Loss Level Sensor Status in TD7 in Compressor status view. This display shows whether the optical sensor is seeing oil (wet) or if it is not (dry).

NOTE: The remainder of the oil charge can be charged into the 1/4 " service valve located at the bottom of the separator if a larger connection is preferred.

Replacing the Main Oil Filter (Hot Filter)

The filter element should be changed if the oil flow is sufficiently obstructed. Two things can happen: first, the chiller may shut down on a "Low Oil Flow" diagnostic, or secondly, the compressor may shut down on a "Loss of Oil" at Compressor (Running) diagnostic. If either of these diagnostics occurs, it is possible the oil filter needs replacement. The oil filter is not usually the cause of a Loss of oil at Compressor diagnostic.

Specifically, the filter must be changed if the pressure drop between the 2 service valves in the lubrication circuit exceeds the maximum level as given in Figure below. Each of the charts RTHF shows the relationship between the pressure drop measured in the lubrication circuit as compared with operating pressure differential of the chiller (as measured by pressures in the condenser and evaporator).

Normal pressure drops between the service valves of the lubrication circuit are shown by the lower curve. The upper curve represents the maximum allowable pressure drop and indicates when the oil filter must be changed. Pressure drops that lie between the lower and upper curves are considered acceptable.

For a chiller equipped with an oil cooler, add 35 kPa to the values shown in Figure. For example, if the system pressure differential was 550 kPa, then the clean filter pressure drop would be approximately 100 kPa (up from 70 kPa). For a chiller with an oil cooler and operating with a dirty oil filter, the maximum allowable pressure drop would be 190 kPa (up from 160 kPa).

Under normal operating conditions the element should be replaced after the first year of operation and then as needed thereafter.

Maintenance Procedures

Figure 13 – Oil Filter Replacement Chart for RTHF

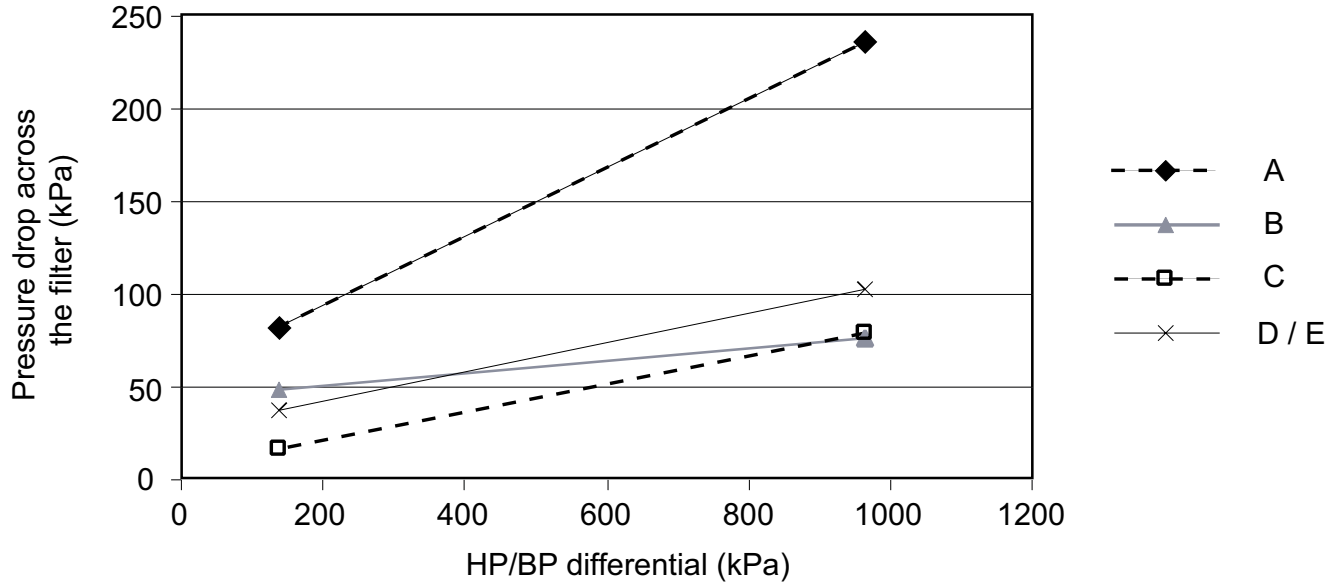

- A = Maximum pressure drop
- B = B compressors
- C = C compressors
- D/E = D and E compressors



Maintenance Procedures

Refrigerant Charge

Refrigerant recovery

1. Insure that the water flow is maintained on condenser and evaporator during all the recovery operation.
2. Connections on evaporator and condenser are available to remove the refrigerant. Weigh the refrigerant removed.

CAUTION !

Never recover refrigerant without maintaining nominal water flow on heat exchangers during all the recovery operation. Evaporator or condenser could freeze and bringing severe damages to the unit.

3. Use a "refrigerant transfer machine" and adequate service cylinders to stock the recovered refrigerant.
4. According to its quality, use recovered refrigerant to charge the unit or give it to refrigerant producer for recycling or elimination.

Evacuation and Dehydration

1. Disconnect ALL power before/during evacuation.
2. Connect the vacuum pump to the 5/8 " flare connection on the bottom of the evaporator and/or condenser.
3. To remove all of the moisture from the system and to insure a leak free unit, pull the system down below 500 microns.
4. After the unit is evacuated, perform a standing rise test for at least an hour. The pressure should not rise more than 150 microns. If the pressures rises more than 150 microns, either a leak is present or moisture still in the system.

NOTE: If oil is in the system, this test is more difficult. The oil is aromatic and will give off vapors that will raise the pressure of the system.

Refrigerant Charging

Once the system is deemed leak and moisture free, use the 5/8 "flare connections at the bottom of the evaporator and condenser to add refrigerant charge. Refer to Table 1 and unit nameplate for refrigerant charge information.

Recommended service routine frequencies

As a commitment to our customers, we have created a wide service network staffed with experienced factory-authorized technicians. At Trane we offer all the benefits of after sales service direct from the manufacturer and we are committed to our mission statement to provide efficient customer care.

We would be delighted to discuss your individual requirement with you. For further information regarding Trane maintenance agreements please contact your local TRANE sales office.

Year	Commis- sioning	Inspec- tion visit	Seasonal shut- down	Seasonal start up	Oil analysis (2)	Vibration Analysis (3)	Annual mainte- nance	Preven- tive Mainte- nance	Tube analysis (1)	Compressor R'newal (4)
1	x	x	x	x		X		xx		
2			x	x	x		x	xxx		
3			x	x	x		x	xxx		
4			x	x	x		x	xxx		
5			x	x	x	X	x	xxx	x	
6			x	x	x	X	x	xxx		
7			x	x	x	X	x	xxx		
8			x	x	x	X	x	xxx		
9			x	x	x	X	x	xxx		
10			x	x	x	X	x	xxx	x	
over 10			every year	every year	every year (2)	X	every year	every 3 year	every 3	40000 h

This timetable is applicable to units operating in normal conditions with an average of 4000 hours per year.

If operating conditions are abnormally severe, an individual timetable must be made for that unit.

1. Tube testing required if aggressive water conditions exist. Applies to condensers only on water cooled units.
2. Schedule as per previous analysis result or at least once a year.
3. Year 1 to define equipment baseline. Subsequent year based on oil analysis results or schedule as per vibration analysis.
4. Recommended at 40 000 run hours or 100 000 equivalent operating hours whichever comes first. Schedule also depends on results from oil analysis / vibration analysis.

Seasonal start up and shutdown are mainly recommended for Comfort Air Conditioning and annual and preventive maintenance are mainly recommended for Process application.



Additional services

Oil analysis

Trane Oil Analysis is a predictive tool used to detect minor issues before they become major problems. It also reduces failure detection time and allows planning for appropriate maintenance. Oil changes can be reduced by half resulting in lower operating costs and a lower impact on the environment.

Vibration analysis

Vibration analysis is required when oil analysis reveals the presence of wear indicating the start of possible bearing or motor failure. Trane oil analysis has the ability to identify the type of metallic particles in the oil which, when combined with the vibration analysis, will clearly point out the failing components.

Vibration analysis should be performed on a regular basis to build a vibration trend of the equipment and avoid unplanned downtime and costs.

Compressor R'newal

To ensure a long lifetime for Trane compressors, system oil and vibration are regularly analyzed. These tests build a detailed picture of the condition of internal system components. Over time, they also help build a 'wear trend' of the equipment. This informs our service experts whether your compressor is due for minor maintenance or a complete overhaul.

System upgrade

This Service provides a consulting service.

Upgrading your equipment will increase the unit reliability and can reduce the operating costs by optimizing the controls. A list of solutions / recommendations to the system will be explained to the customer. Actual upgrade for the system will be costed separately.

Water treatment

This Service provides all of the necessary chemicals to properly treat each water system for the period designated.

The inspections will be conducted at agreed upon intervals and Trane Service First will submit a written report to the customer after each inspection.

These reports will indicate any corrosion, scaling, and alga growth in the system.

Refrigerant analysis

This Service includes a thorough analysis for contamination and solution upgrade.

It is recommended that this analysis be performed every six months.

Annual cooling tower maintenance

This Service includes the inspection and maintenance of the cooling tower at least once a year.

This involves checking the motor.

24 hours duty

This service includes emergency calls outside of the office normal working hours.

This Service is only available with a Maintenance Contract, where available.

Trane Select Agreements

Trane Select Agreements are programs tailored to your needs, your business and your application. They offer four different levels of coverage. From preventive maintenance plans to fully comprehensive solutions, you have the option of selecting the coverage that best suits your requirements.

5 years motor-compressor warranty

This Service will provide a 5 years part and labor warranty for the motor compressor only.

This Service is only available for units covered by a 5 years Maintenance Contract.

Tube analysis

- Eddy Current Tube Testing for prediction of tube failure/ wear
- Frequency - every 5 years for first 10 years (depending on the water quality), then every 3 years thereafter.

Energy enhancement

With Trane Building Advantage you can now explore cost effective ways to optimize the energy efficiency of your existing system and generate immediate savings. Energy management solutions are not only for new systems or buildings. Trane Building Advantage offers solutions designed to unlock energy savings in your existing system.

Trane - by Trane Technologies (NYSE:TT), a global climate innovator - creates comfortable, energy efficient indoor environments for commercial and residential applications. For more information, please visit trane.com or tranetechnologies.com.

Trane has a policy of continuous product and product data improvement and reserves the right to change design and specifications without notice. We are committed to using environmentally conscious print practices.

RLC- SVX021D-GB May 2020
Supersedes RLC-SVX021C-GB_0919)

© 2020 Trane

Confidential and proprietary Trane information