

Instruction Manual

CVS Type 630 HP Regulators and Relief Valves

Introduction

Please note: These regulators and relief valves must be installed, operated and maintained in accordance with CVS instructions and all applicable federal, provincial, state and local codes, laws, rules, and regulations.

The CVS 630 HP Series consists of a high pressure reducing regulator, and Type CVS 630R relief valve. These regulators and relief valves are furnished in either spring-loaded or pressure-loaded construction with 1 or 2 inch NPT screwed end connections.

Pressure loaded Type 630 HP regulators are normally furnished without a main regulator spring and use a Bellofram 7360 or a Bellofram P39 regulator.

Pressure loaded Type 630R relief valves are furnished with a light rate relief valve spring and use a Bellofram 7360 or a Bellofram P39 regulator.

Installation

After uncrating the regulator or relief valve, inspect it for shipping damage. Be certain the body cavity and seat ring are free from any foreign material. Also be certain that connecting pipelines are free of loose pipe scale.

The regulator or relief valve may be installed in any position, but direction of flow through the body must be as indicated by the flow direction arrow on nameplate.



Figure 1: CVS Type 630HP Regulator

Note that in diagrams in this manual, regulator flow direction is opposite relief valve flow direction.

Protect the regulator or relief valve against damage from vehicles and other external sources. The temperature capability of the 630 HP Series regulator and relief valves with standard construction materials is -20 to $+150^{\circ}\text{F}$.

Head Office
3900 - 101 Street
Edmonton, Alberta, Canada T6E 0A5
Office: (780) 437-3055
Fax: (780) 436-5461

CVS
Controls Ltd.

Calgary Sales Office
3516 114 Avenue SE
Calgary, Alberta, Canada T2Z 3V6
Office: (403) 250-1416
Fax: (403) 291-9487

Website: www.cvs-controls.com E-Mail: info@cvs-controls.com

Vents

Spring-loaded constructions have a screened vent assembly (Key 24) installed in the 1/4" NPT spring case vent opening. If a remote vent is required, remove the vent assembly and install a remote vent line.

Pressure loaded constructions have a bleed orifice fitting (Key 38) installed in an extra outlet connection of the loading regulator. The function of this fitting is to bleed loading pressure during operation of the regulator or relief valve.

Warning: The bleed orifice fitting continuously vents a small amount of gas. If the regulator or relief valve is located where accumulation of the vented gas will create an explosion hazard, install a remote vent line to carry the vented gas to a safe area. The bleed orifice is furnished with a 1/4" NPT screened opening; remove the screen and install remote vent line.

All remote vent lines must have as large an inside diameter as possible. The vent line should be as short as possible with a minimum number of bends and elbows. Protect all vent openings against entrance of rain, snow or any other foreign material that may plug the vent or affect operation of the regulator or relief valve. Inspect all vent openings periodically to be sure they are not plugged.

Overpressure Protection

As is the case with most regulators, the Type 630 HP spring-loaded and pressure-loaded regulators have outlet pressure ratings that are lower than the inlet pressure ratings. Overpressure protection must be provided if the actual inlet pressure can exceed the outlet pressure rating. Overpressure protection may also be required for the loading regulator and main regulator spring case of pressure loaded regulators and relief valves.

Refer to the following tables to determine pressure ratings:

1. Spring loaded Type 630 HP regulators
 - 1.1. Inlet pressure and pressure drop (Table 1)
 - 1.2. Outlet pressure (Table 2)
2. Pressure loaded Type 630 HP regulators
 - 2.1. Main regulator inlet pressure and pressure drop (Table 1)
 - 2.2. Loading pressure and outlet pressure (Table 3)
3. Spring loaded Type 630R relief valve pressure (Table 4)
4. Pressure loaded Type 630R relief valve pressures (Table 5)

WARNING: Over pressuring any portion of this equipment may cause damage to regular parts, leaks in the regulator or personal injury due to bursting of pressure-containing parts or explosion of accumulated gas.

To prevent overpressure, provide an appropriate overpressure protection device to ensure that none of the limits listed in tables 1 through 5 will be exceeded.

Regulator or relief valve operation below the limits specified in tables 1 through 5 does not preclude the possibility of damage from external sources or from debris in the gas line. Inspect the regulator for damage following any over pressuring condition.

Loading Regulator Supply Pressure

Use a clean, dry gas as supply pressure for the loading regulator of pressure loaded regulators or relief valves. Connect the supply to the 1/4" NPT inlet connection of the loading regulator. The supply pressure may be obtained from the upstream piping, but be certain adequate overpressure protection is provided for the loading regulator and for the spring case of the main regulator or relief valve.

Table 1: Maximum Inlet Pressures and Pressure Drops for CVS Type 630 HP Regulators

	1/8" & 3/16" Port Diameter	1/4" Port Diameter	3/8" Port Diameter	1/2" Port Diameter
Max. Allowable Inlet Pressure, (PSIG)	1500*	1500*	1000*	750*
Max. Allowable Pressure Drop, ** (PSIG)	1500	1000	500	250

Does not apply to loading regulator of pressure-loaded Type 630 HP.

+ Inlet pressure must not exceed the sum of the actual outlet pressure setting and the maximum allowable pressure drop. For example, with an outlet pressure setting of 200 psig and a 3/8" port dia. (maximum allowable pressure drop of 500 psig), the maximum allowable inlet pressure is 700 psig.

++ Nitrile valve discs are normally furnished for pressure drops to 200 psi. For better erosion resistance, nylon valve discs are normally furnished for higher-pressure drops.

Some erosion of valve discs occurs at all pressure drops due to solid particles in the flow stream. The rate of erosion is higher with large amounts of impurities in the flow stream and with higher pressure drops. Valve discs and other regulator parts must be inspected periodically for erosion and damage and must be replaced as necessary.

Table 2: Outlet Pressure Limits for Spring-Loaded CVS Type 630 HP Regulators

	Low-Pressure Regulator				High-Pressure Regulator						
Outlet Pressure range	3 to 10 psig	8 to 20 psig	17 to 30 psig	27 to 40 psig	27 to 50 psig	46 to 95 psig	90 to 150 psig	150 to 200 psig	200 to 275 psig	275 to 500 psig	
Spring Part Number	CVS0W 0192 27022	CVS0W 0191 27022	CVS0W 0190 27022	CVS0Y 0664 000A2	CVS0W 0192 27022	CVS0W 0191 27022	CVS0W 0190 27022	CVS0Y 0664 000A2	CVS1J 1469 27142	CVS1K 3709 27082	
Maximum Operating Outlet Pressure, PSIG	10	20	30	40	50	95	150	200	275	500	
Max. Outlet Pressure Over Pressure Setting ¹ , PSIG	20		20 ²	Ltd. By Max. emr Outlet Pr.	200					200 ³	
Max. Emergency Outlet (Casing) Pressure, PSIG	45				550						
1. Damage to internal parts of the regulator may occur if outlet pressure exceeds the actual pressure setting by amounts greater than shown in this row. 2. For outlet pressure settings to 25 psig only. For pressure settings over 25 psig, outlet pressure is limited by max. emergency outlet pressure of 45 psig. 3. For outlet pressure settings to 350 psig only. For pressure settings over 350 psig, outlet pressure is limited by max. emergency outlet pressure of 550 psig. 4. Leakage or bursting of pressure-containing parts may occur if outlet pressure exceeds these values.											

Table 3: Loading Pressure and Outlet Pressure Limits for Spring-Loaded CVS Type 630 HP Regulators

	Low-Pressure Regulator		High-Pressure Regulator	
Loading Regulator Type	Bellofram 7360	Bellofram P39	Bellofram 7360	Bellofram P39
Max. Inlet Pressure to loading regulator, psig	250	6000	250	6000
Outlet Pressure Ranges, ² psig	0 to 30 0 to 60	0 to 225	0 to 120	50 to 225 200 to 500
Max. Operating Outlet Pressure, ² psig	60		100	500
Max. Main Regulator Outlet Pressure Overpressure Setting, ³ psig	20 ⁴		200	200 ⁵
Max. Emergency Outlet (Casing) Pressure of Loading Regulator, ⁶ psig	70 ⁷		110	550
Max. Emergency Outlet (Casing) Pressure of Main Regulator, ⁶ psig	70		600	
1. Limited to this value by maximum inlet pressure to Type 630 HP 2. Applies to both loading regulator and main regulator. 3. Damage to internal parts of the regulator may occur if outlet pressure exceeds the actual pressure setting by amounts greater than those shown in this row. Loss of loading pressure to main regulator diaphragm will reduce outlet pressure settings in proportion to the loss in loading pressure. 4. For pressure settings to 46 psig. For higher-pressure settings, outlet pressure is limited by max. emergency outlet pressure of 66 psig. 5. For pressure settings to 350 psig. For higher-pressure settings, outlet pressure is limited by max. emergency outlet pressure of 550 psig. 6. Leakage or bursting of pressure-containing parts may occur if outlet pressure exceeds these values. 7. Limited to this value by maximum emergency loading pressure of main regulator.				

Table 4: Relief Valve Pressure Limits for Spring-Loaded CVS Type 630R Regulators

	Low Pressure Relief Valve					High Pressure Relief Valve			
Max. Allowable Inlet Pressure, psig	Relief Pressure Setting Plus Maximum Allowable Buildup of 25 psig					Relief Pressure Setting Plus Maximum Allowable Buildup of 250 psig			
Max. Emergency Inlet (Casing) Pressure, ¹ psig	75					550			
Relief Pressure Settings (psig)	3 to 8	6 to 17	15 to 22	20 to 35	27 to 50	30 to 70	50 to 95	75 to 175	150 to 250
Spring Part Number	CVS0W 0192 27022	CVS0W 0191 27022	CVS0W 0190 27022	CVS0Y 0664 000A2	CVS1J 1469 27142	CVS0W 0191 27022	CVS0W 0190 27022	CVS0Y 0664 000A2	CVS1J 1469 27142
Leakage or bursting of pressure-contained parts may occur if inlet pressure exceeds these values									

Table 5: Relief Valve Pressure Limits for Pressure-Loaded CVS Type 630R Regulators

Loading Regulator Type	Low Pressure Relief Valve	High Pressure Relief Valve	
	Bellofram 7360	Bellowfram 7360	Bellofram P39
Max. Allowable Inlet Pressure to Relief Valve, PSIG	Relief pressure setting plus maximum Allowable buildup of 25 psig	Relief pressure setting plus maximum Allowable buildup of 250 psig	
Max. Emergency Inlet (Casing) Pressure * of Relief Valve, PSIG	75	550	550
Max. Allowable Inlet Pressure to Loading Regulator, PSIG	75+	250	550+
Relief Pressure Settings, PSIG	10 to 20 or 20 to 50	50 to 100	100 to 225
Max. Emergency Outlet (Casing) Pressure * of Loading Regulator, PSIG	75++	110	250

* Leakage or bursting of pressure-contained parts may occur if pressure exceeds these values.
 + Limited to this value by maximum emergency inlet pressure of relief valve.
 ++ Limited to this value by maximum emergency loading pressure of Type 630R

Putting Unit in Service

Use pressure gauges to monitor pressure during startup.

1. For pressure loaded constructions, turn on supply pressure to loading regulator.
2. Slowly open upstream shutoff valve.
3. Slowly open the downstream shutoff valve.
4. Check all connections for leaks.
5. If indicated by the monitoring pressure gauges, make final spring adjustments per the "Adjustment" section.

Adjustment

The range of allowable pressure settings is marked on the nameplate. If a pressure setting beyond the nameplate range is required, substitute an appropriate spring in the relief valve or loading regulator. Be sure to change the nameplate to indicate the new pressure range.

Some pressure ratings are dependent upon the actual outlet pressure settings being used. For example, with a Type 630 HP regulator, outlet pressure must not exceed the setting by more than 20 psig (200 psig for high-pressure constructions), or damage to internal regulator parts may occur. However, with some higher-pressure ranges, the setting plus 20 psig (200 psig for high-pressure constructions) exceeds the maximum emergency outlet (casing) pressure. In these cases, outlet pressure must be limited by the maximum emergency outlet (casing) pressure. Before increasing the setting, refer to table 2 through 5 (as appropriate). Review the pressure limits for the spring range being used, and be certain that the new pressure setting will not result in an overpressure condition. Always use a pressure gauge to monitor pressure when making adjustments.

Spring Loaded Regulators and Relief Valves

1. Loosen locknut (Key 22)
2. Rotate the adjusting screw (Key 23) clockwise to increase the setting or counter clockwise to decrease the setting.
3. Tighten locknut.

Pressure Loaded Regulators and Relief Valves

1. Loosen the locknut found on the loading regulator adjusting screw.
2. Rotate the loading regulator adjusting screw clockwise to increase the setting or counterclockwise to decrease the setting.
3. Tighten locknut.

Taking out of Service

Isolate the regulator or relief valve from all pressure. For pressure loaded constructions, shut off supply pressure to loading regulator.

Cautiously vent all pressure from the regulator or relief valve before performing any service on the unit.

Maintenance

WARNING: To avoid personal injury and equipment damage, isolate the regulator or relief valve from all pressure. Cautiously release pressure from the regulator or relief valve before attempting disassembly.

Due to normal wear that may occur in regulators and relief valves, parts such as the valve disc, seat ring and diaphragm must be inspected periodically and replaced as necessary. The frequency of inspection and replacement depends upon the severity of service conditions or federal and provincial laws. Normal wear of the seat ring and valve disc is accelerated with high-pressure drops and with large amounts of impurities in the flow stream. Instructions are given below for replacing the seat ring, valve disc and diaphragm. These instructions may also be used for disassembly required for inspection and replacement of other parts.

If the loading regulator of pressure-loaded constructions requires maintenance, disconnect the supply pressure line (and bleed orifice vent line if one is present) and unscrew the loading regulator from its mounting nipple. Refer to the separate instruction manual for maintenance information.

Seat Ring and Valve Disc:

Note: With some piping systems it may be possible to omit step 1 below by removing four cap screws (Key 7) and spreading the body (Key 1) and adaptor (Key 6) far enough apart to allow removal of the seat ring (Key 4) and Type 630 HP valve disc (Key 3) or Type 630R valve seat O-ring (Key 32). However, take care to avoid pinching fingers between body and adapter.

1. Disconnect piping from Adapter (Key 6). Remove four cap screws (Key 7) and adapter.
2. Remove seat ring (Key 4) and gaskets (Key 5).
3. To remove Type 630 HP valve disc (Key 3) OR Type 630R valve seat O-ring (Key 32), first disconnect remote vent pipe (if one is used). For pressure loaded constructions, disconnect loading regulator supply line.
4. Unscrew the two cap screws that secure the diaphragm adaptor (Key 11) to body (Key 1); remove diaphragm adaptor and attach spring case (Key 21).
5. Remove valve carrier assembly (Key 2) from body.
6. To replace seating surface:
 - 6.1. For Type 630 HP, use a $\frac{3}{4}$ " socket wrench to remove and re-install valve disc and holder assembly (Key 3).
 - 6.2. For Type 630R, unscrew machine screw (key31) and remove O-ring washer and O-ring (Key 28 and 32) from O-ring holder (Key 3). When reassembling, apply a good quality gasket shellac to the machine screw thread.
7. Use new seat ring gaskets (Key 5) and body gasket (Key 8) when reassembling. Insert valve carrier assembly (Key 2) into the body before re-installing the diaphragm adaptor.
8. The spring case (Key 21) must point away from the adaptor (Key 6) on Type 630 HP regulators. On Type 630R relief valves, the spring case must face the same direction as the adaptor (Key 6). Be certain the lever (Key 10) engages the valve carrier.

Diaphragm

1. Relieve spring compression as follows:
 - 1.1 For spring loaded constructions, loosen locknut (Key 22). Turn the adjusting screw (Key 23) counterclockwise until spring compression is relieved.
 - 1.2 For pressure loaded Type 630R relief valves (and for pressure loaded Type 630 HP regulators that have been furnished with a spring), turn cap screw (Key 23) counterclockwise until spring compression is relieved.
2. Disconnect remote vent line (if one is present).
3. For pressure loaded constructions, disconnect the supply line from the loading regulator (Key 25).
4. Remove spring case (Key 21) by unscrewing cap screws and nuts (Key 14).
5. Remove diaphragm (Key 13) and attached parts from lever assembly (Key 10).
6. Unscrew cap screw (Key 18) from connector head assembly (Key 12) and disassemble the diaphragm assembly.
7. Install new diaphragm. Note that low-pressure constructions use a diaphragm plate (Key 16) on the spring case side of the diaphragm. Low pressure, pressure loaded constructions use a diaphragm plate on each side of the diaphragm plate gasket (Key 33) with each plate. Install new gaskets when replacing diaphragm.
8. When reassembling, be certain that the diaphragm connector is engaged on the lever.

- 9. To ensure proper slack in the diaphragm:
 - 9.1 For constructions using a spring, tighten the spring case cap screws finger tight only. Compress the spring slightly with the adjusting screw (or cap screw for pressure loaded constructions); then complete the tightening of spring case cap screws and nuts.
 - 9.2 For constructions without a spring, tighten spring case cap screws finger tight only. Remove cap screw (Key 23). Insert a rod in the spring case and push on the assembly to take up the slack; then complete the tightening of the spring case cap screws. Re-install cap screw (Key 23) in spring case.

Nameplate Information

When corresponding with your CVS Controls representative about this device, state the model number, pressure range and all other pertinent information found on the nameplate (Key 29). When ordering replacement parts, also specify the complete part number of each part required.

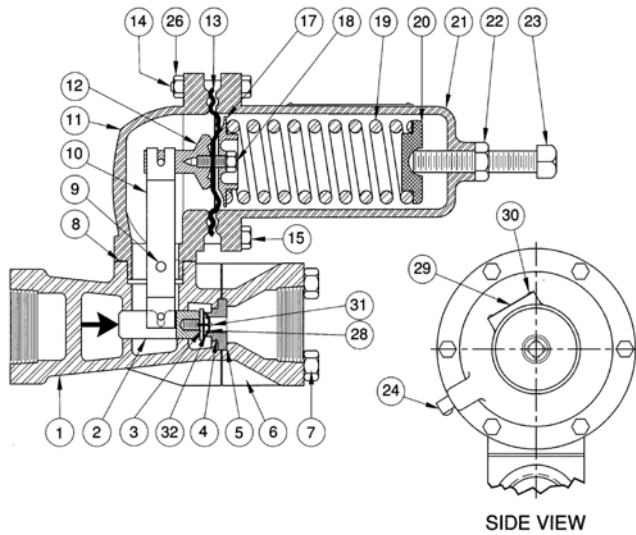

Figure 1: Spring-Loaded CVS Type 630R Relief Valve High Pressure Connection

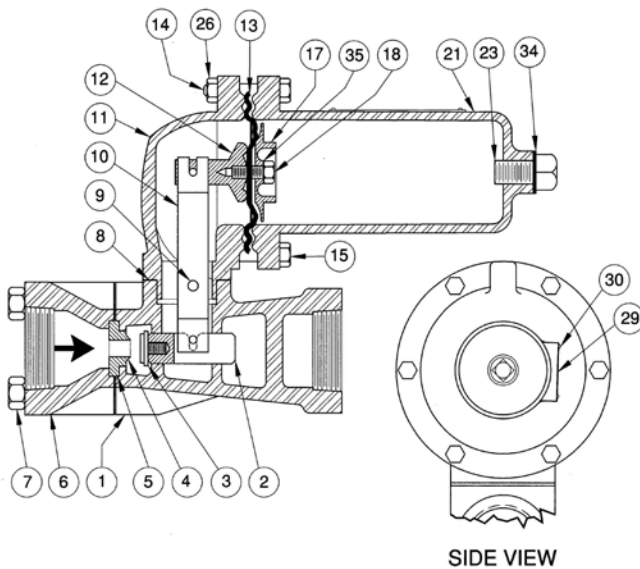
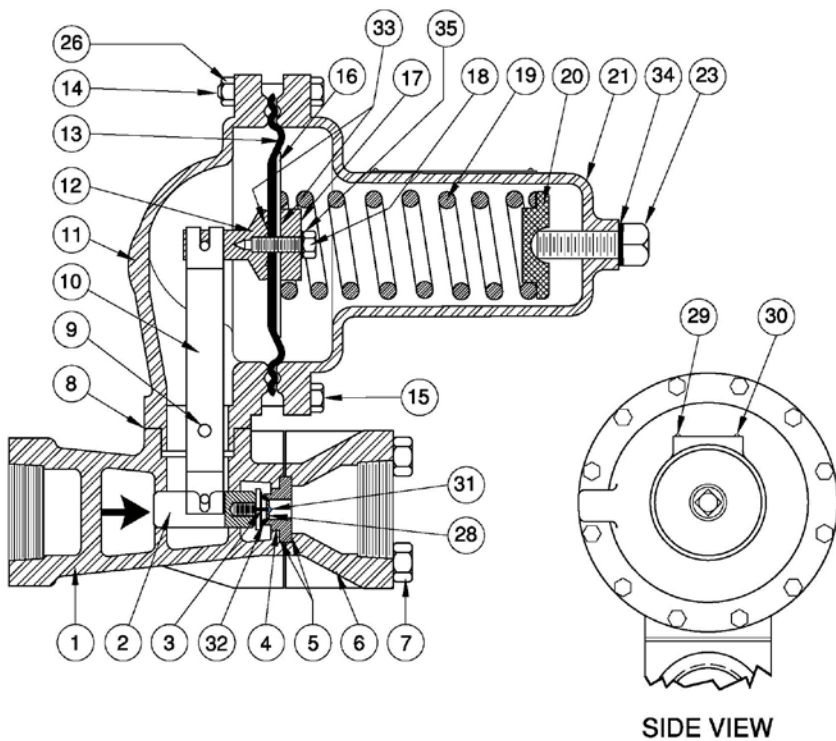

Figure 2: Pressure-Loaded CVS Type 630 Regulator High Pressure Connection

Parts Reference

Key	Description
1	Body
2	Valve Carrier
3*	Type 630R O-Ring Holder Type 630* Valve Disc Assembly
4	Seat Ring
5	Gasket (2 required)
6	Inlet Adaptor, Steel
7	Cap Screw, Steel (4 required)
8*	Gasket
9	Pin, SST
10	Lever Assembly
11	Diaphragm Adaptor
12	Connector Head Assembly
13*	Diaphragm, Neoprene
14	Cap Screw, Steel
15	Cap Screw, Steel
16	Diaphragm Plate, Steel Cd. Pl.
17	Lower Spring Seat
18	Cap Screw, Steel Pl.
19	Spring
20	Upper Seat Ring, Zinc
21	Spring Case
22	Hex Nut, Steel Cd. Pl.
23	Adjusting Screw, Steel
24	Vent Assembly (Spring Loaded Only)
25	Loading (Pressure Loaded Only)
26	Hex Nut, Steel Cd. Pl.
27	Cap Screw, Steel Pl.
28	O-Ring Washer (Pressure Loaded Only)
29	Nameplate
30	Drive Screw, SST
31	Machine Screw (CVS Type 630R Only)
32	O-Ring
33	Head Gasket (Pressure Loaded Only)
34	Gasket (Pressure Loaded Only)
35	Gasket (Pressure Loaded Only)
36	Pipe Nipple (Pressure Loaded Only)
37	Street Elbow
38	Bleed Orifice Assembly (Pressure Loaded Only)



**Figure 3: Spring-Loaded CVS Type 630R Relief Valve
Low Pressure Connection**

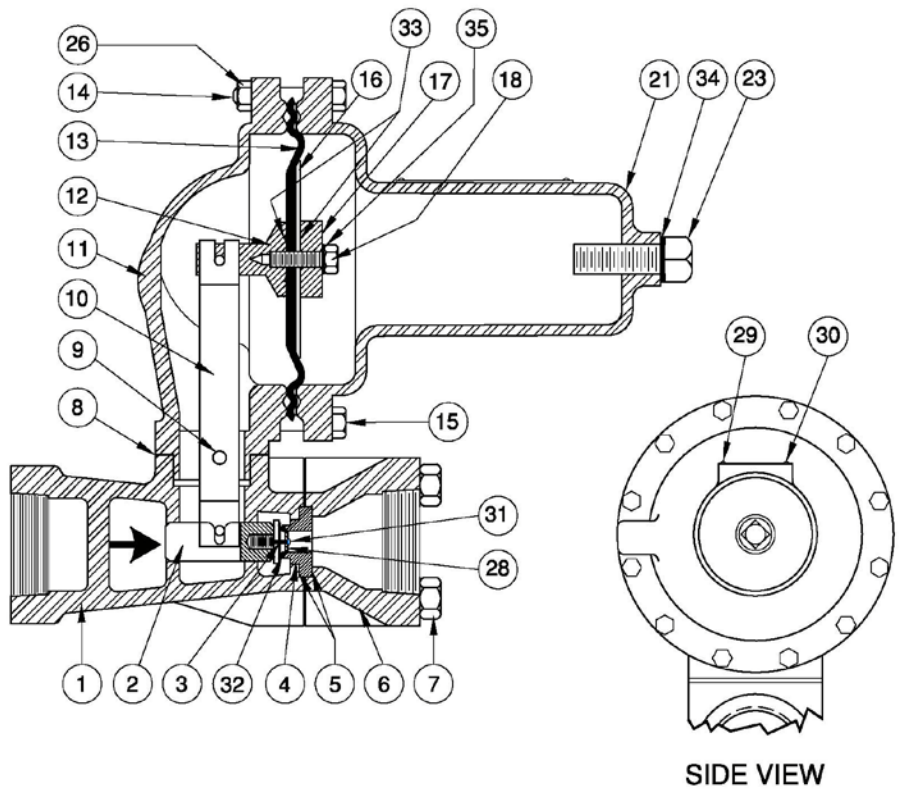

**Figure 4: Pressure-Loaded CVS Type 630R Relief Valve
Low Pressure Connection**

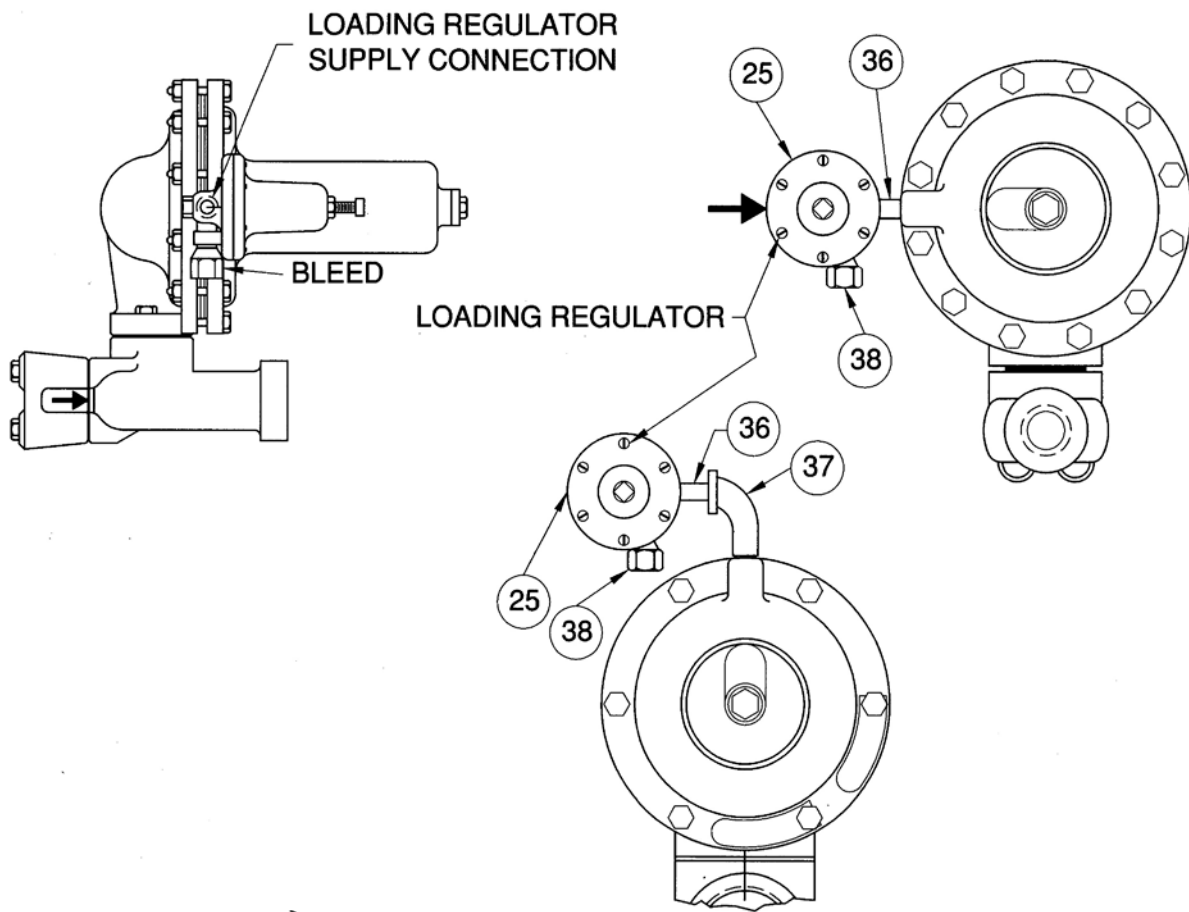

**Figure 5: Pressure-Loaded CVS Type 630 Regulator
Low Pressure Connection**

CVS Type 630 HP Regulators and Relief Valves

Parts List

Key No.	Description		Part #	
1	Body	1" Cast Iron w/ brass pitot tube	CVS0W0209000A2	
		1" Cast Iron w/ SST pitot tube	CVS0W0209X0012	
		1" Steel w/ brass pitot tube	CVS2N6990000A2	
		1" Steel w/ SST pitot tube	CVS2N6990X0012	
		2" Cast Iron w/brass pitot tube	CVS0W021519012	
		2" Steel w/ SST pitot tube	CVS2N699122012	
2	Valve Carrier	Brass	CVS0W018614022	
		SST	CVS0W018635032	
3	O-Ring Holder, Type 630R	Brass	CVS1D336014012	
		SST	CVS1D336035032	
	Valve Disc Assembly, Type 630	Brass/Nitrile	CVS1B4500000A2	
		SST/Nitrile	CVS1B4500000B2	
		Brass/Nylon	CVS1C1860000A2	
		SST/Nylon	CVS1C1860000B2	
		Brass/TFE	CVS1C1860000C2	
		SST/TFE	CVS1C1860000D2	
4	Seat Ring, Type 630	Brass	1/8" Port	CVS0Z040014012
			3/16" Port	CVS1B219514102
			1/4" Port	CVS0W018314012
			3/8" Port	CVS0W018214012
			1/2" Port	CVS0W018114012
		SST	1/8" Port	CVS1K416635032
			3/16" Port	CVS1K416535032
			1/4" Port	CVS1K416435032
			3/8" Port	CVS1K416335032
			1/2" Port	CVS1K416235032
	Seat Ring, Type 630R	Brass	1/2" Port	CVS1B735014012
			SST	CVS1B735035032
		SST	1/2" Port	CVS1B735035032
			1/2" Port	CVS1B735035032
5	Gasket (2 Req'd)	Copper, For Brass Trim	CVS0W018415042	
		Garlock	CVS0W018404022	
6	Inlet Adaptor, Steel	1-inch Body	CVS1F479823022	
		2-inch Body	CVS1F479923022	
7	Cap Screw, Steel (4 Req'd)	1-inch Body	CVS1A935924052	
		2-inch Body	CVS1A353524052	
8	Gasket, Asbestos		CVS0W018704022	
9	Pin, SST		CVS0W018835072	
10	Lever Assembly	Low-Pressure	CVS1B2891000A2	
		High-Pressure	CVS1B2890000A2	
11	Diaphragm Actuator	Low-Pressure	Cast Iron	CVS0W019719012
			Steel	CVS2N698522012
		High-Pressure	Cast Iron	CVS0W019819012
			Steel	CVS2N698722012
12	Connector Head Assembly	Low-Pressure	Brass	CVS1C3000X0012
			SST	CVS1C3000X0022
		High-Pressure	Brass	CVS1P8465000A2
			SST	CVS1P8465000B2
13	Diaphragm, Neoprene	Low-Pressure	CVS0W020002192	
		High-Pressure	CVS0W019902192	
14	Cap Screw, Steel	Low-Pressure (10 Req'd)	CVS1A352524052	
		High-Pressure (4 Req'd)	CVS1A352524052	
15	Cap Screw, Steel	Standard (2 Req'd)	CVS1A352624052	
		Wire Seal (1 of Each Req'd)	CVS1R419124052	
			CVS1A352624052	
16	Diaphragm Plate, Steel Cd. Pl.	630 and 630R, Low-Pressure, Pressure-Loaded	CVS1B136324052	
		All Others	CVS1A352524052	
17	Lower Spring Seat	Low-Pressure, Steel	CVS0W020324102	
		High-Pressure, Zinc	Pressure Range to 275	CVS0W020144022
			Pressure Range over 275	CVS1K371044022
18	Cap Screw, Steel Pl.	630 and 630R, Low-Pressure, Pressure-Loaded	CVS1B136324052	
		All Others	CVS1R817699012	

CVS Type 630 HP Regulators and Relief Valves Parts List cont'd

Key No.	Description			Part #
19	Spring			See Following Table
20	Upper Spring Seat, Zinc	630 Pressure Loaded		None Required
		630 and 630R, and 630R Pressure-Loaded	Pressure Range to 275	CVS0W019344022
21	Spring Case		Low Pressure	Cast Iron
		Steel		CVS3N698122012
		High Pressure	Cast Iron	CVS3C780819042
			Steel	CVS3N698322012
22	Hex Nut, Steel Cd. Pl.			CVS1A352424122
23	Adjusting Screw, Steel			See Following Table
24	Vent Assembly (Not Required for Pressure-Loaded Units)			CVSEMY602X1A12
25	Loading Regulator (For Pressure-Loaded Only)			Type 67, 67H, 1301F or 1301G
26	Hex Nut, Steel Cd. Pl.	Low-Pressure (10 Req'd)		CVS1A352724122
		High-Pressure (4 Req'd)		CVS1A352724122
27	Cap Screw, Steel Pl. (2 Req'd) (Not Shown)			CVS1A341827052
28	O-Ring Washer (For Pressure-Loaded Units Only)	Brass		CVS1D335914012
		SST		CVS1D335935072
29	Nameplate, Aluminum	Type 630		CVS1F749611032
		Type 630R		CVS21A5495X012
30	Drive Screw, SST (4 Req'd)			CVS1A368228982
31	Machine Screw, Type 630R Only	Brass		CVS1A682618992
		SST		CVS1D336435042
32	O-Ring	Nitrile		CVS1D288806992
		TFE		CVS1F581906522
33	Head Gasket, Garlock (2 Req'd), (For Pressure-Loaded Units Only)			CVS1B192204022
34	Gasket, Copper (For Pressure-Loaded Units Only)			CVS0Y008915042
35	Gasket, Copper and Garlock (For Pressure-Loaded Units Only)			CVS1E275999212
36	Pipe Nipple, Steel Galvanize Zn Pl (Pressure-Loaded Units Only)			CVS1B218826232
37	Street Elbow, Malleable Iron (High-Pressure, Pressure-Loaded Units)			CVS1A913221992
38	Bleed Orifice Assembly (Pressure-Loaded Only)	Low Pressure	3-20 psig Loading Regulator Range	CVS1K8845X0012
			20-100 psig Loading Regulator Range	CVS1K8844X0012
		High-Pressure		CVS1K8843X0012

Key 23: Adjusting Screw, Steel

Type	Spring	Use Adjusting Screw	For Wire Seal, Use Adjusting Screw
CVS 630	CVS0W019227022	CVS1A279128982	CVS1R829928992
	CVS0W019127022	CVS1B212028982	CVS1R830028992
	CVS0W019027022	CVS1A500528982	CVS1R808528992
	CVS0Y0664000A2	CVS1A500528982	CVS1R808528992
	CVS1J146927142	CVS1A500528982	CVS1R808528992
	CVS1K370927082	CVS1A500528982	CVS1R808528992
	None *	CVS1C116227092	---
CVS 630R	CVS0W019227022	CVS1A279128982	CVS1R829928992
	CVS0W019127022	CVS1B212028982	CVS1R830028992
	CVS0W019027022	CVS1A500528982	CVS1R808528992
	CVS0Y0664000A2	CVS1D336628982	CVS1R830128992
	CVS1J146927142	CVS1D336628982	CVS1R830128992
	CVS0W019227022*	CVS1E359024492	---

* Pressure-Loaded Construction

Key 19: Regulator Spring, Steel

Type		Outlet (or Relief) Pressure Setting, PSIG	Spring Part Number	Spring Colour Code
Spring-Loaded Type 630	Low-Pressure	3 to 10	CVS0W019227022	Red Stripe
		8 to 20	CVS0W019127022	Olive Drab
		17 to 30	CVS0W019027022	Cadmium
		27 to 40	CVS0Y0664000A2	Green Stripe
	High-Pressure	27 to 50	CVS0W019227022	Red Stripe
		46 to 95	CVS0W019127022	Olive Drab
		90 to 150	CVS0W019027022	Cadmium
		150 to 200	CVS0Y0664000A2	Green Stripe
		200 to 275	CVS1J1469270142	Blue Stripe
	275-500	CVS1K370927082	Yellow Stripe	
Spring-Loaded Type 630R	Low-Pressure	3 to 8	CVS 0W019227022	Red Stripe
		6 to 17	CVS0W019127022	Olive Stripe
		15 to 22	CVS0W019027022	Cadmium
		20 to 35	CVS0Y0664000A2	Green Stripe
		27 to 50	CVS1J146927142	Blue Stripe
	High-Pressure	30 to 70	CVS0W019127022	Olive Drab
		50 to 95	CVS0W019027022	Cadmium
		75 to 175	CVS0Y0664000A2	Green Stripe
		150 to 250	CVS1J146927142	Blue Stripe
Pressure-Loaded Type 630 R	Low-Pressure	10 to 20 or 20 to 50	CVS0W019227022	Red Stripe
	High-Pressure	50 to 100 or 100 to 225	CVS0W019227022	Red Stripe

CVS Controls Ltd. strives for the highest levels of quality and accuracy. The information included in this publication is presented for informational purposes only. CVS Controls Ltd. reserves the right to modify or change, and improve design, process, and specifications without written notice. Under no circumstance is the information contained to be interpreted to be a guarantee/warranty with regard to our products or services, applicability or use. Selection, use and maintenance are the sole responsibility of the end user and purchaser. CVS Controls assumes no liability for the selection use and maintenance of any product.