

# Crystal Nightlight



## Warning.

Not suitable for children under 8 years. For use under adult supervision. Contains some chemicals which present a hazard to health. Read the instructions before use, follow them and keep them for reference. Do not allow chemicals to come into contact with any part of the body, particularly the mouth and eyes. Keep small children and animals away from experiments. Keep the experimental set out of reach of children under 8 years old.

**WARNING** — This set contains chemicals and/or parts that may be harmful if misused. Read cautions on individual containers and in manual carefully. Not to be used by children except under adult supervision.



## Safety information

### WARNING.

Not suitable for children under 3 years. Choking hazard — small parts may be swallowed or inhaled.

Keep the packaging and instructions as they contain important information.

## First aid information

Advice in case any accidents should happen during experimentation.

**1. In case of eye contact:** Wash out eye with plenty of water, holding eye open if necessary. Seek immediate medical advice.

**2. If swallowed:** Wash out mouth with water, drink some fresh water. Do not induce vomiting. Seek immediate medical advice.

**3. In case of inhalation:** Remove person to fresh air.

**4. In case of skin contact and burns:** Wash affected area with plenty of water for at least 10 minutes.

**5. In case of doubt,** seek medical advice without delay. Take the chemical and its container with you.

**6. In case of injury** always seek medical advice.

## Poison control

Poison Control Centers (United States)

In case of emergency, your nearest poison control center can be reached everywhere in the United States by dialing the number:

**1-800-222-1222**

Local Hospital or Poison Centre (Europe)

Record the telephone number of your local hospital or poison centre here:

Write the number down now so you do not have to search for it in an emergency.

## Notes on disposal of electrical components



None of the electrical or electronic components in this kit should be disposed of in the regular household trash when you have finished using them. Instead, they must be delivered to a collection location for the recycling of electrical and electronic devices. The symbol on the product, instructions for use, or packaging will indicate this. The materials are reusable in accordance with their designation. By reusing or recycling used devices, you are making an important contribution to the protection of the environment. Please consult your local authorities for the appropriate disposal location.

## Advice for parents and supervising adults

With this crystal growing set, you will be accompanying your child on a journey into the fascinating world of crystals. It is natural to have questions about the safety of a kit that contains chemicals. The experimental equipment in this kit complies with safety standards that specify the safety requirements for crystal growing sets. These standards impose obligations on the manufacturer, such as forbidding the use of any particularly dangerous substances. The standards also stipulate that adults should assist their children with advice and assistance in their new hobby.

A. Read and follow these instructions, the safety rules and the first aid information, and keep them for reference.

B. The incorrect use of chemicals can cause injury and damage to health. Only carry out those experiments which are listed in the instructions.

C. This experimental set is for use only by children over 8 years.

D. Because children's abilities vary so much, even within age groups, supervising adults should exercise discretion as to which experiments are suitable and safe for them. The instructions should enable supervisors to assess any experiment to establish its suitability for a particular child.

E. The supervising adult should discuss the warnings and safety information with the child or children before commencing the experiments. Particular attention should be paid to the safe handling of crystal growing chemicals and solutions.

F. The area surrounding the experiment should be kept clear of any

obstructions and away from the storage of food. It should be well lit and ventilated and close to a water supply. A solid table with a heat resistant top should be provided.

G. Substances in non-reclosable packaging should be used up (completely) during the course of one experiment, i.e. after opening the package.

Hot water is used in the production of crystal salt solution. You should devote special care to handling it safely and assist your child when help is needed. Make sure there is no fire risk when heating water on the kitchen stove!

While experimenting, please be careful not to let the crystal salts (chemicals) come into contact with the skin, eyes, or mouth. It is also important not to let the crystal salts, their solutions, or especially the finished crystals get into the hands of young children.

While growing crystals, the electronic components and the die-cut figure pieces should be stored safely in the experiment kit box, in order to prevent them from getting damaged (by spilled liquids, for example).

The work area should not be in the kitchen, as chemicals should be kept strictly separate from foods and kitchen equipment. A cool basement room would be ideal. Do not use any containers or tools in the kitchen after you have used them for growing crystals.

Always get any required equipment and chemicals ready before beginning an experiment.

We hope you and your child have a lot of fun growing your crystal nightlight!

# Safety rules

Read this before starting any experiments

1. Read these instructions before use, follow them and keep them for reference.
2. Keep young children and animals away from the experimental area.
3. Store this experimental set and the final crystal(s) out of reach of children under 8 years of age.
4. Clean all equipment after use.
5. Ensure that all empty containers and/or non-reclosable packaging are disposed of properly.
6. Wash hands after carrying out experiments.
7. Do not eat or drink in the experimental area.
8. Do not allow chemicals to come into contact with the eyes or mouth.
9. Do not apply any substances or solutions to the body.
10. Do not grow crystals where food or drink is handled or in bedrooms.
11. Do not use any equipment which has not been supplied with the set or recommended in the instructions for use.
12. Take care while handling hot water and hot solutions.
13. Ensure that during growing of the crystal the container with the liquid is out of reach of children under 8 years of age.
14. Do not use any eating, drinking, or other kitchen utensils for your experiments. Any containers or equipment used in your experiments should not be used in the kitchen afterward.
15. If chemicals should come in contact with eyes, mouth, or skin, follow the first aid advice (inside front cover of this manual) and contact a doctor if necessary.
16. Never work alone. An adult should always be present. Also, pay attention to the information on the chemical labels, the “Information about hazardous substances” on page 3, as well as the safety information provided with the individual experiments (for example, having to do with handling hot liquids).
17. Be particularly careful with hot burners, and don't forget to turn them off after use!
18. Pay special attention to the quantity specifications and the sequence of the individual steps. Only perform experiments that are described in this instruction manual.
19. When working, wear appropriate protective clothing (old clothes).
20. Always hold containers of hot materials such that their openings are pointing away from yourself or others. Do not inhale hot vapors that are released while heating!
21. Read and follow the warnings on the packages of any additionally required items, such as the all-purpose glue.

**NOTE!** *The additionally required items are highlighted in italic script in the individual experiments. Before starting the experiments, carefully read through everything that will be required and make sure to have all the materials ready.*

## Advice for growing crystals safely

To open the crystal salt packet, cut the packet open at one corner with a pair of scissors. Never use your teeth. Be sure that the printing on the packet remains legible.

If the crystal salt has formed clumps, it does not mean there is anything wrong with the quality of the contents. It means that some moisture has gotten in. This will not affect its function. The age of your crystal salt will likewise make no difference.

Cleanliness is especially important in chemistry. So always clean up any used containers and your workplace immediately after finishing the experiments. Then wash the containers with clean water and dry them with a paper towel, which you should then throw into the trash.

Since you will only be working with small amounts of a harmless chemical, you can just wash liquid waste down the sink with plenty of water. Solid waste can go into the household garbage.

## Information about hazardous substances

Here is information about handling the substance contained in this kit. Please note the following hazard and precautionary statements for the chemical contained in this kit:

**Potassium aluminium sulfate (alum):**

Avoid breathing dust. Do not get in eyes, on skin, or on clothing.

**Warning.** The following applies to all chemicals: Store locked up. Keep out of reach of children.

This primarily applies to young children, but also to older children who — unlike the experimenter — have not been appropriately instructed by adults.

Also follow this precautionary statement: **IF SWALLOWED:** Get immediate medical advice/attention and have product container or label of chemical substance at hand.

If any chemicals inadvertently get onto the skin, rinse off immediately under running water. Always be careful not to inhale chemical dust or powder when experimenting.

## Notes on experimenting with batteries



- Warning. Only for use by children aged 8 years and older. Instructions for parents or other supervising adults are included and have to be observed. Keep the packaging and instructions as they contain important information.
- The wires are not to be inserted into socket-outlets. Never perform experiments using household current! The high voltage can be extremely dangerous or fatal!
- Two AAA batteries (1.5-volt/LR03) are required, which could not be included in the kit due to their limited shelf life.
- Different types of batteries or new and used batteries are not to be mixed.
- Do not mix old and new batteries.
- Do not mix alkaline, standard (carbon-zinc), or rechargeable (nickel-cadmium) batteries.
- Batteries are to be inserted with the correct polarity. Press them gently into the battery compartment. See page 13. Always close the battery compartment of your base with the lid.
- Non-rechargeable batteries are not to be recharged. They could explode!
- Rechargeable batteries are only to be charged under adult supervision.
- Rechargeable batteries are to be removed from the toy before being charged.
- Exhausted batteries are to be removed from the toy.
- The supply terminals are not to be short-circuited. A short circuit can cause the wires to overheat and the batteries to explode.
- Dispose of used batteries in accordance with environmental provisions, not in the household trash.
- Be sure not to bring batteries into contact with coins, keys, or other metal objects.
- Avoid deforming the batteries.
- Have an adult check the base before you use it so you can be sure it was assembled properly!

# KIT CONTENTS

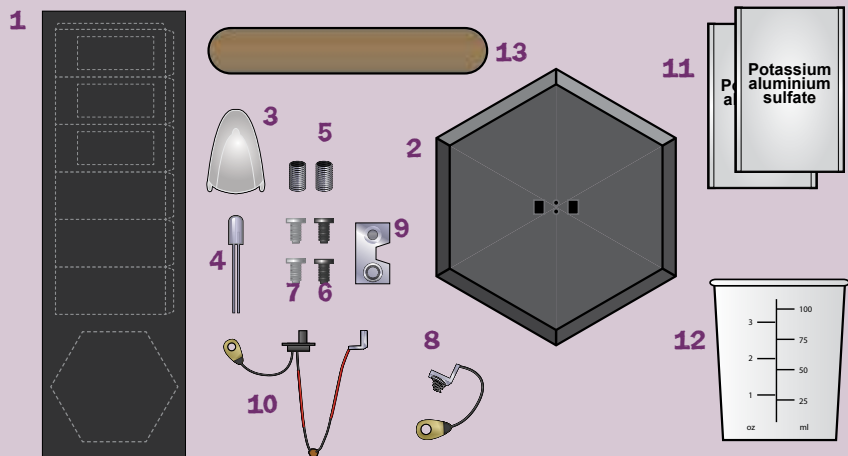

- |   |                                          |    |                                                     |
|---|------------------------------------------|----|-----------------------------------------------------|
| 1 | Die-cut black cardboard                  | 9  | Double contact latch                                |
| 2 | Plastic base with lid                    | 10 | Switch with eyelet and contact latch                |
| 3 | Transparent plastic cone                 | 11 | Potassium aluminium sulfate powder (alum), 50 g (2) |
| 4 | Color-changing LED                       | 12 | Measuring cup, 100 ml                               |
| 5 | Contact springs (2)                      | 13 | Wooden spatulas (2)                                 |
| 6 | Black screws (2)                         |    |                                                     |
| 7 | Silver screws (2)                        |    |                                                     |
| 8 | Black wire with eyelet and contact latch |    |                                                     |

**YOU WILL ALSO NEED:** Two clean empty jelly jars (about 600 ml, one with a lid), paper, pencil, scissors, tape, water, old pot and hot pad, pot holders, paper towels, a piece of cardboard, sturdy string, ruler, all-purpose glue, tweezers, small Phillips-head ("crosshead") screwdriver, two AAA batteries (1.5-volt, type LR03).

## Hey Crystal Growers!

Ready to grow a beautiful crystal and make it into a cool nightlight that will glow in a spectrum of colors? First you'll grow the crystal from alum powder, then you'll wire up the nightlight circuitry, then you'll put them both together! Let's get started! Rocky the Geeker will be your guide!

Hi! I'm Rocky!





# PART 1

# THE CRYSTAL TAKES SHAPE

## Growing starter crystals

### You will need:

One packet of alum, measuring cup, wooden spatula, 2 empty, clean jars, one with a lid, paper, pencil, scissors, tape, water, old pot and hot pad, pot holder, paper towels, piece of cardboard

### Here's how:

- 1 Pour the entire alum packet (50 g) into a labeled jar. Pour in 200 ml of water (measure 100 ml twice).
- 2 Now get your hot pad ready at the experiment area. Fill the old pot with enough tap water to cover the bottom about 3 cm deep, and bring the water to a boil on the stove.
- 3 Carry the pot carefully to the experiment area and set it on the hot pad. Place the jar with the alum into the pot and stir the contents with the wooden spatula until all the alum is dissolved. When all the alum is dissolved, take the jar out of the pot with the pot holder and dry it off with a paper towel. CAREFUL, IT'S HOT!

### TIP!

Use a pencil or a ball-point pen to write "alum solution" on a narrow strip of paper or label, then tape the paper to the glass jar. If you use self-adhesive labels, cover them with cellophane tape.

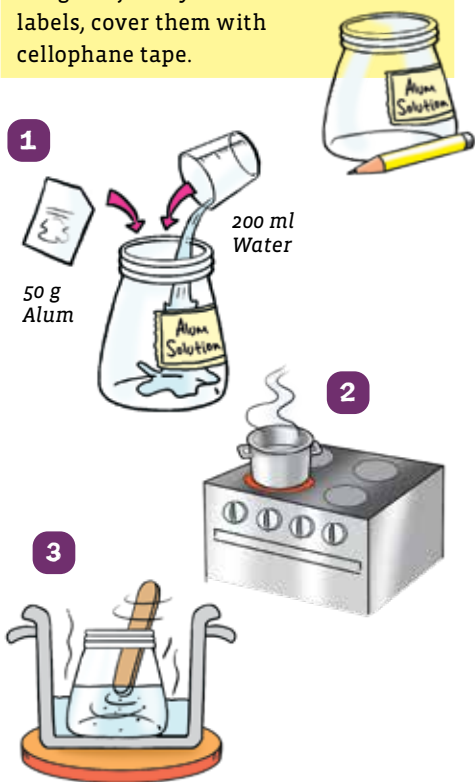

### CAUTION!

Have an adult help you! Be careful not to burn yourself on the hot stove, and don't forget to turn the stove off afterwards!



## TIP!

If all of the alum did not dissolve, take the jar out of the pot with the pot holder and reheat the water on the stove. Bring the pot back to the experiment area and heat the liquid in the jar once again.

4 Place the piece of cardboard in a safe location and set the jar on it. Cover it with a paper towel so no dust falls in. Take a look at it every now and then to see what's happening.

5 Let the jar sit overnight. Once crystals that are about 5 mm in size have developed, pour the rest of the alum solution into a second labeled jar. Don't throw it away — you will still need it!

If you still can't find any little crystals, let the jar sit a while longer. If the crystals have grown too large, just break them up with the wooden spatula.

6 Fish the crystals out with the spatula and let them dry on a double layer of paper towels. You will need them in the next experiment. Screw the lid onto the jar with the alum solution and save it for Experiment 3.

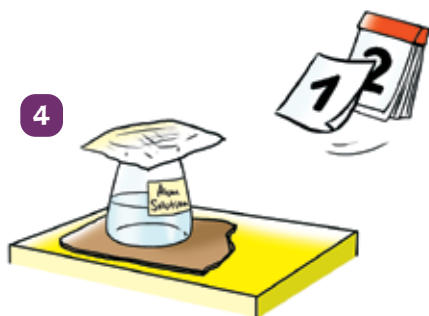
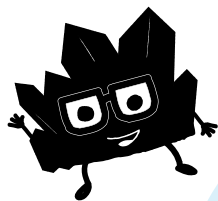

**GEEK  
OUT!**

## WHAT'S HAPPENING?

The hot water in the pot heats the water in the jar. That rapidly dissolves the alum crystal salt, which turns invisible. The liquid in the jar is called an alum solution.

As the solution cools, transparent pointed shapes form on the bottom and sides of the jar. At first they are small, but they grow larger with time. The first crystals have formed!

## Preparing the plastic cone

### You will need:

Transparent plastic cone, dry crystals from Experiment 1, sturdy string, scissors, ruler, all-purpose glue, tweezers

### Here's how:

- 1 Cut two pieces of string, each about 20 cm in length. Tie each one tightly to one of the little "feet" of the plastic cone. Trim a little of the extra string from the short end where you tied it.
- 2 Now glue the little crystals all around the outside of the plastic cone. Do not fill the flat end where the opening is! The best way is to cover one half and let the glue dry before continuing with the other half. You can use a pair of tweezers if you like. Let the cone dry overnight.

You can put any extra crystals in the closed jar with the alum solution. Be sure to wash your hands very thoroughly after this experiment!



### TIP!

Have a friend hold the plastic cone while you tie the knot.

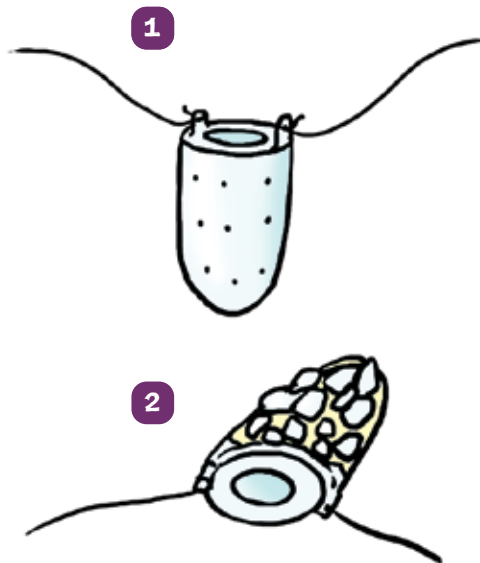

**GEEK  
OUT!**

### WHAT'S HAPPENING?

Your big crystal is going to grow on the plastic cone. For that to happen, the crystal salt particles in the alum solution will have to accumulate on the cone. Since the particles prefer to attach to already-present crystals, the first step was to glue on the little starter crystals.

## Growing a single crystal

### You will need:

Transparent plastic cone with crystals from Experiment 2, jar of alum solution from Experiment 1, 1 packet of alum, measuring cup, 2 wooden spatulas, water, old pot and hot pad, pot holder, paper towels, piece of cardboard

### Here's how:

- 1 Pour the entire packet of alum into the jar of alum solution and add 150 ml of water (measure 75 ml twice). Heat the liquid as described in Experiment 1 until all the alum is dissolved. Dry off the jar with a paper towel (careful, hot!) and set it in the experiment area. Be sure to let the solution cool to room temperature!
- 2 Lay a wooden spatula across the mouth of the jar and tie the plastic cone to it in such a way that the cone is completely immersed in the solution. Just don't let the flat end get submerged under the liquid's surface!
- 3 Set the jar on the piece of cardboard in a safe place and cover the jar with a paper towel. Whenever a layer of little crystals forms on the bottom of the jar, pull the big crystal out and dissolve the little ones in a

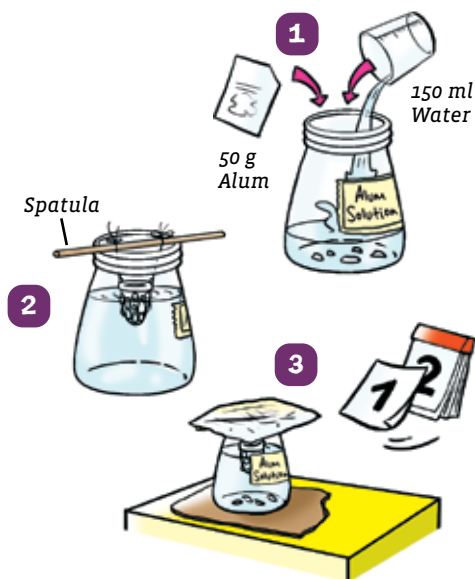

pot of hot water. Always let the liquid cool completely before suspending the big crystal in it again!

When your crystal has grown large enough, leave it on a paper towel to dry and cut off the string.

**GEEK  
OUT!**

### WHAT'S HAPPENING?

The particles of crystal salt from the alum solution don't just settle on the bottom of the jar as the solution cools, they also accumulate on the starter crystals. As that happens, the plastic cone is gradually surrounded by a thicker and thicker layer of crystals, which ultimately looks like one big single crystal. The longer you let the solution sit, the larger it gets.

# WHAT IS SALT, REALLY?

A salt consists of several chemical elements. For example, ordinary table salt consists of the elements **sodium** and **chlorine**. That's why chemists call it **sodium chloride**. All salts form crystals.

In a table salt crystal, the small sodium and chloride particles are always arranged in a specific, orderly pattern. One chloride particle (blue spheres) is always surrounded by six sodium particles (green spheres) — left, right, above, below, in front, and behind.

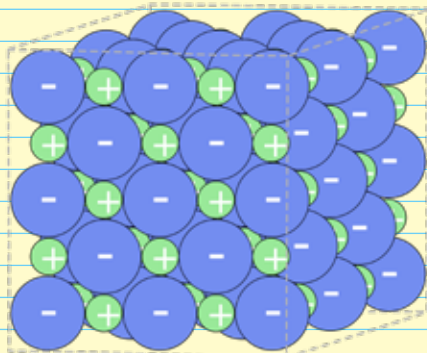

*Sodium chloride structure*

The pattern formed by the particles is called the **crystal lattice** of each type of salt. A salt that consists of other elements will also form a different pattern. The crystal lattice determines how table salt crystals are formed and what shape they take.



## WHAT ELEMENTS DOES ALUM CONSIST OF?

A salt can also consist of more than two elements. Alum consists of potassium, aluminium, and sulfur — hence its chemical name, potassium aluminium sulfate. It also contains oxygen and hydrogen. Compared to table salt, an alum crystal lattice looks pretty complicated, doesn't it?

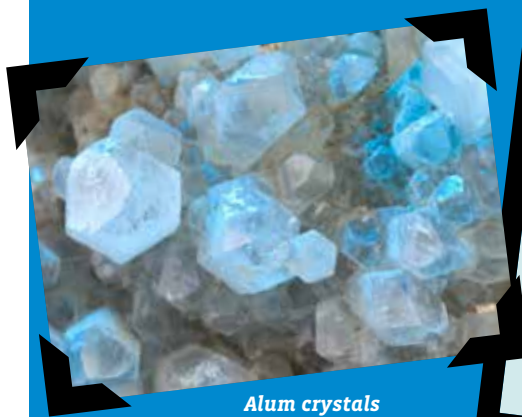

*Alum crystals*

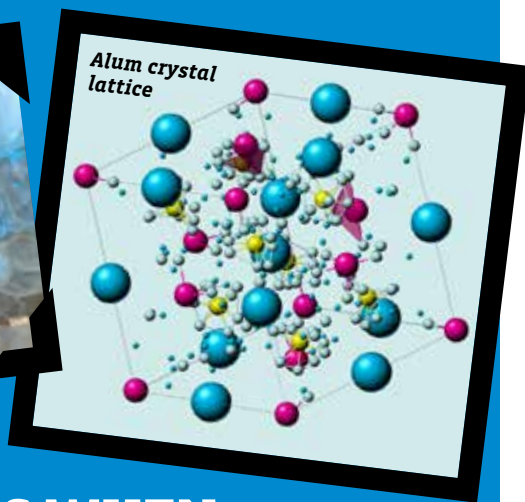

## WHAT HAPPENS WHEN A SALT DISSOLVES?

When a salt dissolves, water molecules **A** push between the salt particles **B** and release them from the crystal lattice. These particles then float around one by one in the water. Since they are so tiny, you cannot see them.

When the water evaporates, the particles recollect and accumulate on one another — in the exact same pattern as before. Once enough particles accumulate, they become visible again — a new crystal has formed!

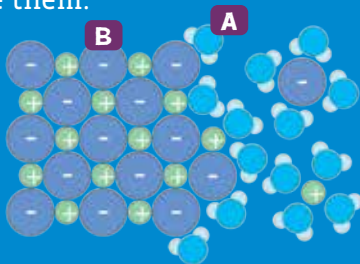

*Salt dissolving*

# PART 2

# GET YOUR CRYSTAL GLOWING

## Let the LED shine!

### You will need:

Plastic pouch with base and small pieces, small Phillips-head screwdriver, two 1.5-volt batteries of type AAA/LR03

### Here's how:

- 1 From the inside, push the switch through the small rectangular opening in the edge of the base **A**. Screw it firmly into place from the outside with the two black screws. Stick the gold-colored eyelet over the left attachment **B** and attach the contact latch to the upper right of the battery compartment **C**.
- 2 Stick the black wire's eyelet over the right attachment **D** and attach the contact latch to the lower right of the battery compartment **E**. Stick the double contact latch to the left of the battery compartment **F**.
- 3 Insert the LED through the two small round holes from the outside. Be sure that the flat side of the LED points to the left.

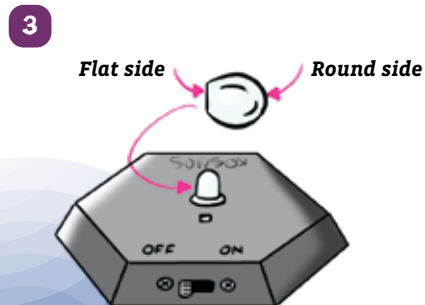
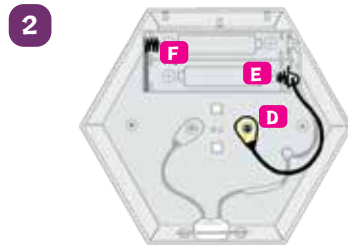
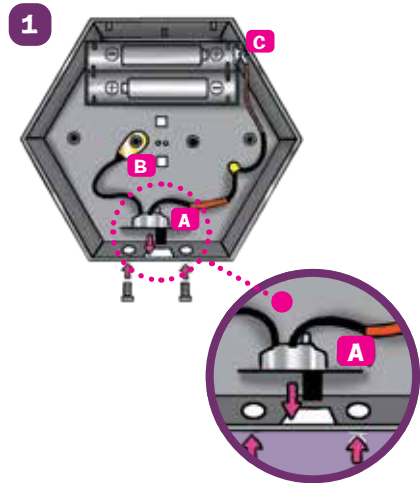



4 On the inside, carefully (!) bend the two terminals (“legs”) of the LED a little to the left and right, and clamp them more or less in the center of the two contact springs. Then, place the springs over the two attachments with the eyelets in such a way that the LED terminals sit in the attachment slots.

5 Insert the batteries into the battery compartment in the correct polarity direction.

6 Close the lid and secure it in place with the two silver screws. Switch on the LED by setting the switch to “ON.”

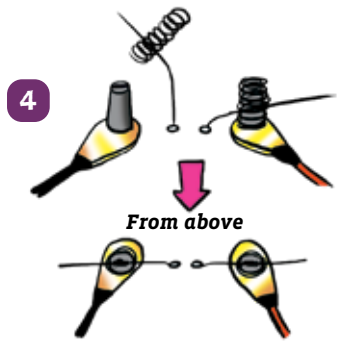

## GEEK OUT!

### WHAT'S HAPPENING?

You have installed an LED into the circuit, and the battery supplies it with energy. The electricity flows from the battery compartment through the switch and then through the LED and back to the battery compartment again.

### Where are LEDs used?

The first LEDs, which could only shine very weakly, were used in things like digital watches. Today's LEDs can produce a lot more light, and they have many applications — in illuminated displays, backlighting for flat screens, traffic lights, and in all sorts of other kinds of lights, such as car headlights, flashlights, and even street lighting.





## Assemble your crystal nightlight and display box

### You will need:

Die-cut figure, your base with LED, your fully dried crystal, *all-purpose glue*

### Here's how:

- 1 Lower your crystal over the LED and insert the little feet of the plastic cone into the two square holes.
- 2 Remove the display box parts from the die-cut sheet and fold them along the marked lines. Glue the display box together as shown in the pictures.
- 3 Lower the display box over the crystal and marvel at the fascinating color show.

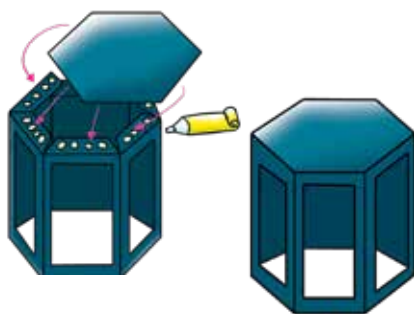
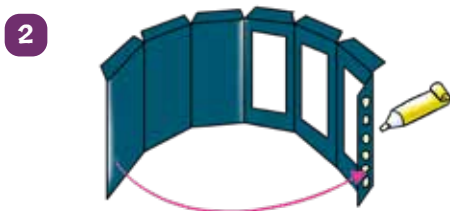

**GEEK  
OUT!**

## WHAT'S HAPPENING?

The color-changing LED actually consists of three different lights — a red one, a green one, and a blue one. By mixing equal parts of red, green, and blue light, you get what our eye sees as white light.

If you reduce the portion of one color or omit it entirely, you can produce any color you like. This effect is known as **additive color mixing**, and it is a little different from the mixing of water color paints, which would give you black if you mixed all the colors (**subtractive color mixing**).

The built-in electronics ensure that the LED lights sometimes shine individually and sometimes together — which produces all the different colors.

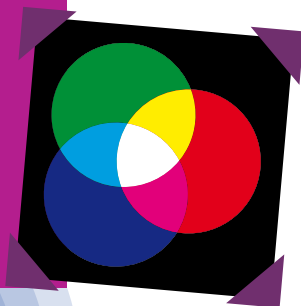

# HOW IS AN LED MADE?

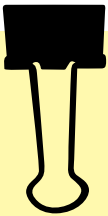

- 1** The transparent **plastic dome** protects the components inside the LED. The round shape distributes the light well.
- 2** A thin connection wire, also called a **bondwire**, connects the crystal (4) to the positive terminal.
- 3** A small concave **mirror** also helps to distribute the light.
- 4** A tiny **semiconductor crystal** is the most important component in the LED. It emits light as soon as current flows through it.
- 5** Two metal **brackets** serve as electrical terminals.
- 6** The **flattened area** marks the negative terminal.
- 7** Connection to the **positive terminal** (long leg).
- 8** Connection to the **negative terminal** (short leg).

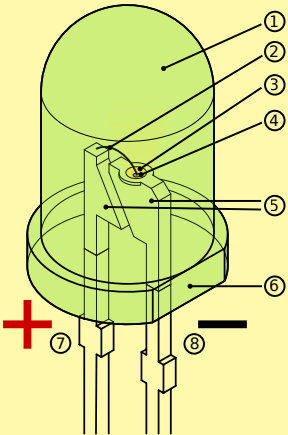

## How does an LED work?

Inside an LED, there is a tiny piece of artificial crystal. Two thin layers of the crystal are treated with two different electrically conductive materials. You can think of it in terms of foreign particles getting smuggled into the crystal. It looks something like the image below.

If an electrical current is connected to both layers, the crystal starts to glow where the two different layers meet. The light is able to penetrate the upper layer and shine out, since the crystal is really thin.

LEDs glow in different colors depending on the material used to make the crystal.

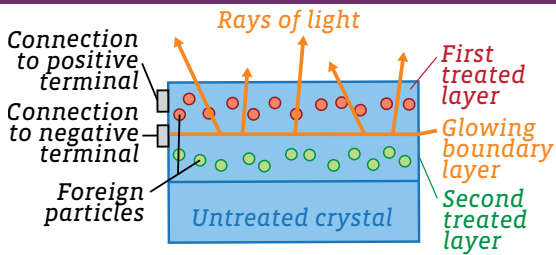



# AMAZING CRYSTAL FACTS!



**A**

Certain crystals will vibrate when electric current passes through them. Many clocks use **quartz** **A** crystals to ensure the watch keeps accurate time. Early radio transmitters used different types of crystals to create the frequencies to transmit signals.

**Quartz** is the most commonly found crystal on earth.

Crystals are often used in jewelry. There are four types that are considered the most valuable and commercially referred to as precious stones. These are **diamonds** **B**, **emeralds** **C**, **rubies** **D**, and **sapphires** **E**.

When we think of crystals we often think of beautiful gems. But did you know that **snowflakes**, **sugar**, **sand**, and **salt** are also crystals?

Colombia is the world's largest producer of **emeralds**, providing more than 50% of the world's production.

A diamond needs only one building block to form: **carbon** atoms. Diamonds are typically made deep inside Earth by carbon atoms being pushed together with amazing amounts of pressure and high temperatures.

Some of the largest crystals ever found are in a cave in Mexico called the *Cueva de los Cristales* (Cave of the Crystals)

**F** This cave is filled with **gypsum** crystals that are up to 36 feet long.

**Diamonds** are the hardest natural material on Earth and are often used for cutting other stones or in polishing tools.

Most minerals occur naturally as crystals. Many minerals are actually colorless but if there are impurities present when the crystal is forming they can form in different colors.

Quartz traditionally is clear, but if iron or manganese impurities are present during the quartz formation you will get a purple quartz called

**amethyst** **G**.



**C**



**D**



**E**



**B**



**F**

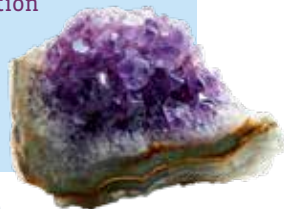

**G**



## Kosmos Quality and Safety

More than one hundred years of expertise in publishing science experiment kits stand behind every product that bears the Kosmos name. Kosmos experiment kits are designed by an experienced team of specialists and tested with the utmost care during development and production. With regard to product safety, these experiment kits follow European and US safety standards, as well as our own refined proprietary safety guidelines. By working closely with our manufacturing partners and safety testing labs, we are able to control all stages of production. While the majority of our products are made in Germany, all of our products, regardless of origin, follow the same rigid quality standards.

# MEET THE GEEKERS!

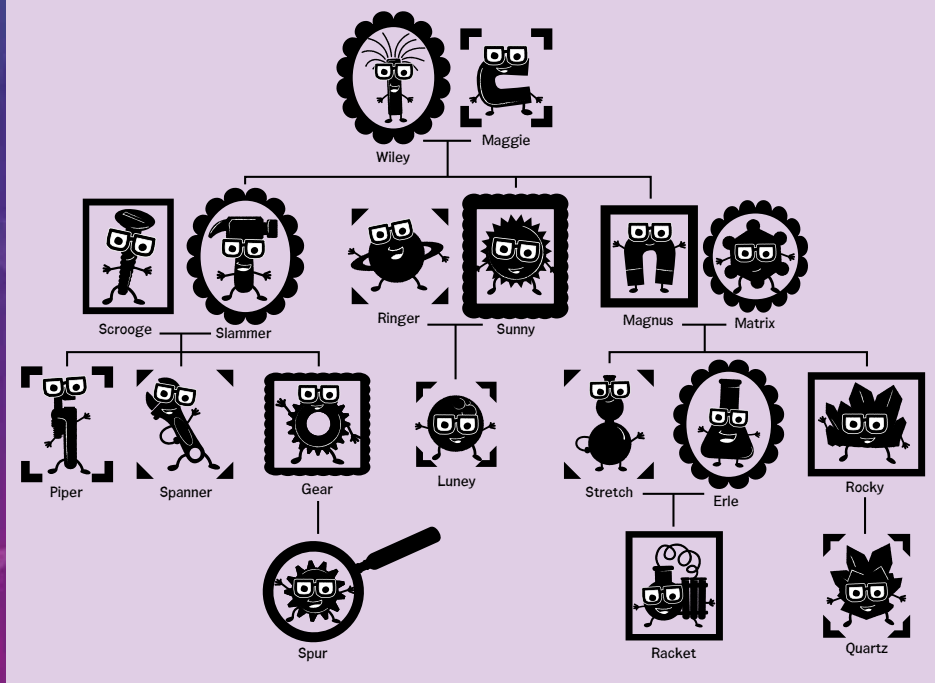

3rd Edition 2015

© 2013, 2015 Franckh-Kosmos Verlags-GmbH & Co. KG,  
Pfizerstr. 5-7, D-70184 Stuttgart, Tel. +49 (0) 711 2191-343

4th English Edition © 2014, 2015, 2018, 2020 Thames & Kosmos,  
LLC, Providence, RI, USA

Thames & Kosmos® is a registered trademark of Thames &  
Kosmos, LLC.

This work, including all its parts, is copyright protected. Any use outside the specific limits of the copyright law without the consent of the publisher is prohibited and punishable by law. This applies specifically to reproductions, translations, microfilming, and storage and processing in electronic systems and networks. We do not guarantee that all material in this work is free from copyright or other protection.

Project management and text: Kristin Albert

Editing: Andreas Hantsch, Freiberg, lektorat & textlabor,  
Christiane Theis, Gärtringen

Technical product development: Dr. Petra Müller

Additional text: Ted McGuire, Amanda Bremmon

Manual photos: Oswald Kunstmann, p. 16 top; Alexandra,  
p. 10 bottom right; TwilightArt-Pictures, p. 10 bottom left;  
Irina Beloturova, p. 16 bottom right (all previous © fotolia.  
com); Gizmo, p. 11 center left; mariusFM77, p. 10 center left;  
Marchcattle, p. 13 bottom left (all previous © istockphoto.  
com); anaken2012, p. 13 bottom right (all previous ©  
shutterstock.com); Roland.chem, p. 10 top right, p. 11  
bottom right (© wikipedia.de, CC-BY-SA-3.0); Inductiveload,

p. 15 top right (© wikipedia.de, public domain); S. C. Nyburg,  
Structure of alum, p. 11 center right; iStock.com, p. 16 b, c, d, e;  
OggiScienza, CC BY ND 2.0, p. 16 bottom left, flickr.com  
Manual illustrations, p. 6-9, 12-14; Andrea Mangold, Munich  
All other illustrations by Dan Freitas, Ashley Greenleaf, and  
Ted McGuire of Thames & Kosmos  
Packaging photos: Michael Flaig, Pro-Studios, Stuttgart  
(contents)  
Packaging artwork and additional photos: Dan Freitas, Ben  
Britton

The publisher has made every effort to locate the holders  
of image rights for all of the photos used. If in any  
individual cases any holders of image rights have not been  
acknowledged, they are asked to provide evidence to the  
publisher of their image rights so that they may be paid an  
image fee in line with the industry standard.

Distributed in North America by Thames & Kosmos, LLC.  
Providence, RI 02903  
Phone: 800-587-2872; Email: support@thamesandkosmos.com

Distributed in United Kingdom by Thames & Kosmos UK LP.  
Cranbrook, Kent TN17 3HE  
Phone: 01580 713000; Web: www.thamesandkosmos.co.uk

We reserve the right to make technical changes.  
Printed in China / Imprimé en Chine