



# GENUINE PARTS

## INSTALLATION INSTRUCTIONS

1. **DESCRIPTION:** Auto-Dimming Mirror with Compass

2. **APPLICATION:** Juke (2011)

3. **PART NUMBER:** 999L1 VT004

4. **KIT CONTENTS:**

Item	Qty	Description	Service Part Number
A	1	EC Compass Mirror	999L1 KT000S2
B	1	Parts Kit	999L1 VT004S1
C	1	• Harness Assembly - Power and Ground	
D	1	• Wire Cover - Short	
E	1	• Wire Cover - Long	
F	1	• Posi-tap	
G	7	• Wire Tie	
H	7	• Foam Tape	
I	2	• A-Pillar Clip	76988 JM00A
J	1	• Manual, Installation Instruction Download	999V2 AW000
K	1	• User Guide	

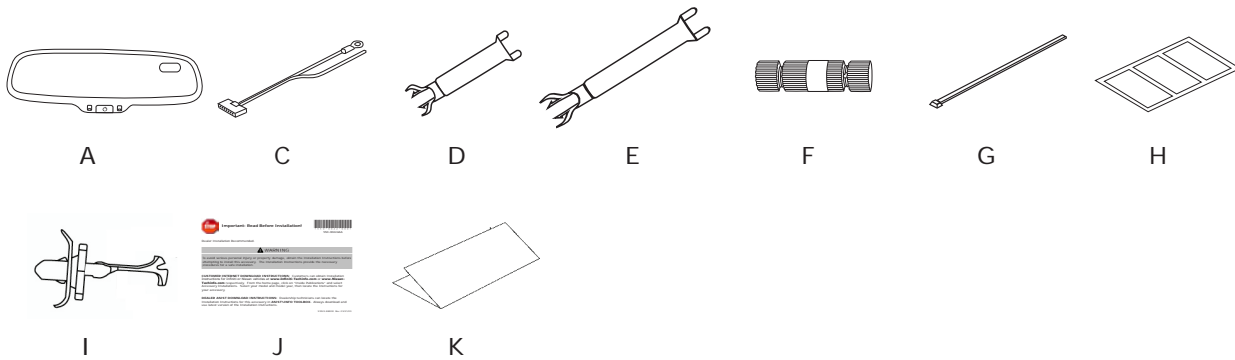

5. **PRE-INSTALLATION CAUTION / NOTES:**

### WARNING

- Disconnect vehicle battery before installing EC mirror to prevent possible shock injury during installation.

### CAUTION

- Place removed vehicle trim components in a clean, dry area to prevent damage.
- This is a universal installation kit so all parts may not be used.

## Auto-Dimming Mirror Kit - Juke

### 6. TOOLS REQUIRED:

- |                       |                          |                         |                         |
|-----------------------|--------------------------|-------------------------|-------------------------|
| 1. Clean Rag          | 3. 10mm Socket Wrench    | 5. 3mm Flat Screwdriver | 7. Side Cutters         |
| 2. Panel Removal Tool | 4. T-20 Torx Head Driver | 6. Torque Wrench        | 8. Phillips Screwdriver |

### 7. VEHICLE PREPARATION:

- 1) Apply parking brake.
- 2) Record the customer radio presets.

Presets	1	2	3	4	5	6	
A							
B							
C							

- 3) Make sure that the shift lever is engaged in the "P" position.
- 4) Turn the ignition switch OFF.
- 5) Open engine hood.
- 6) Disconnect negative battery terminal.

### 8. INSTALLATION PROCEDURE:

#### CAUTION

- Do not use excessive force when removing OE mirror from windshield. The window button may separate from windshield or the windshield could break.

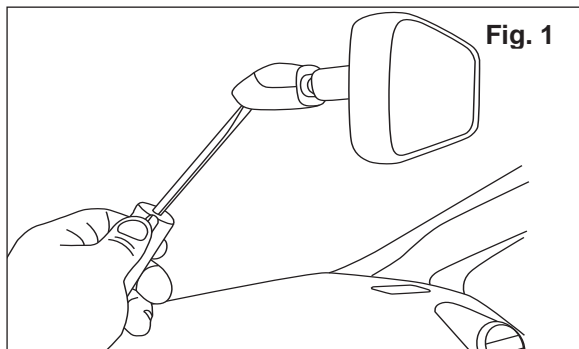

- 1) Removal of OE rearview mirror.
  - a) Insert the flat end of a 3mm screwdriver into the opening at the bottom of the mirror mount. **(Fig. 1)**
  - b) Push screwdriver up into the mount to disengage locking tab. **(Fig. 1)**
  - c) While still applying upward pressure with the screwdriver, grasp the mirror bracket and lift the mirror up towards the headliner and off the mirror mounting bracket. **(Fig. 1)**

## Auto-Dimming Mirror Kit - Juke

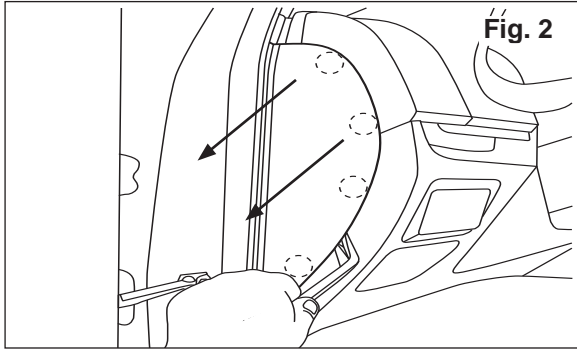

2) Remove driver side instrument side mask.

- a) Using panel removal tool, disengage clips on driver side instrument side mask and remove. **(Fig. 2)**

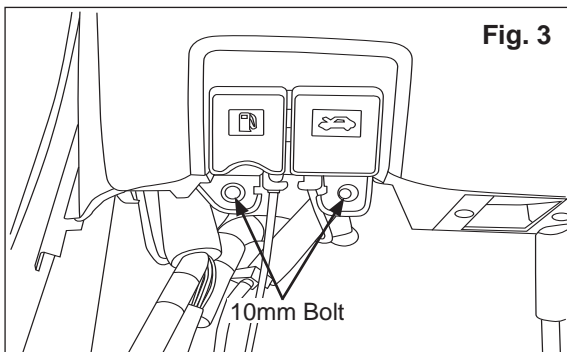

3) Remove driver side instrument lower panel.

- a) Remove 2 10mm bolts securing hood release lever and gas door lever. **(Fig. 3)**

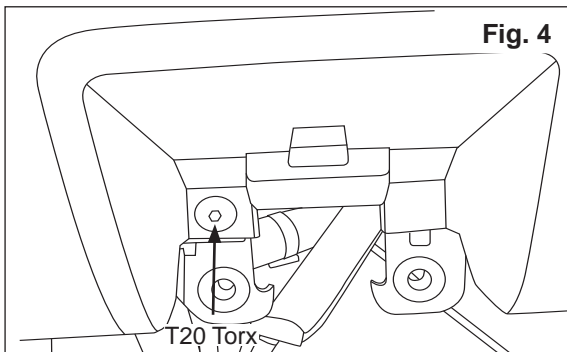

- b) Remove T20 torx screw located behind hood release lever. **(Fig. 4)**

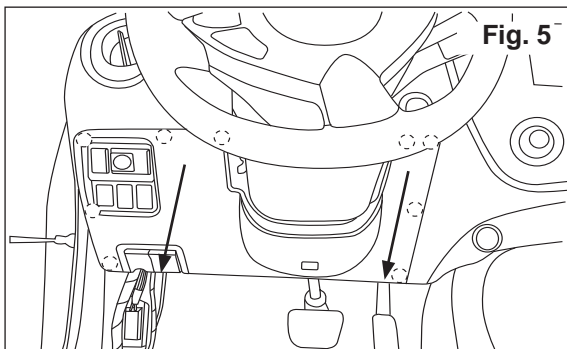

- c) Pull driver side instrument lower panel outward to remove. **(Fig. 5)**

## Auto-Dimming Mirror Kit - Juke

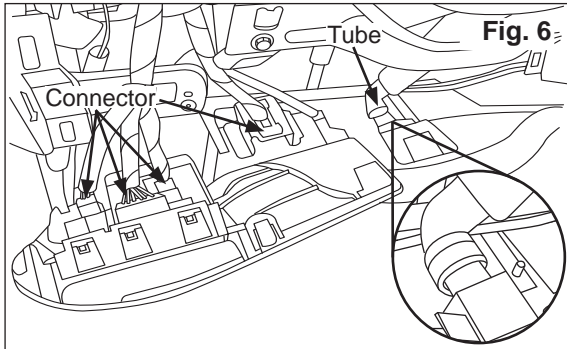

- d) Disconnect all connector's from instrument panel, as well as temperature tube (if present) and remove panel. **(Fig. 6)**

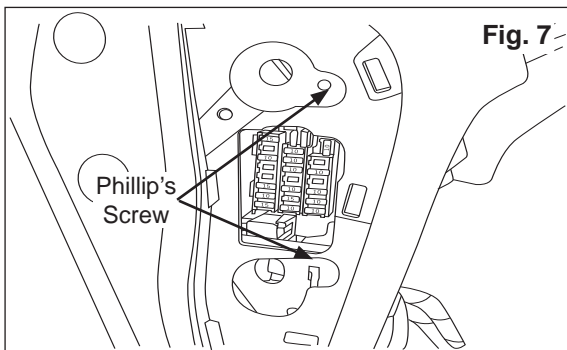

- 4) Partially remove fuse panel.

- a) Using Phillips screwdriver, remove 2 screws and loosen fuse panel. **(Fig. 7)**

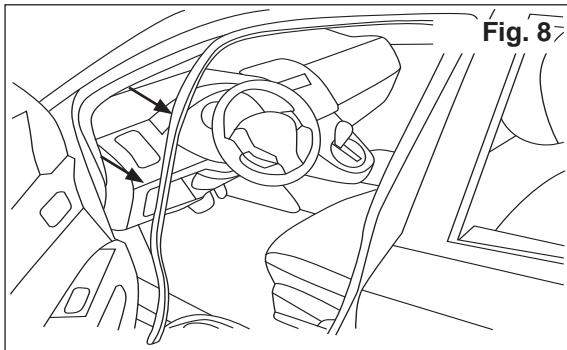

- b) Using panel removal tool, loosen driver side weather strip and remove from top of A-pillar to scuff plate area. **(Fig. 8)**

## Auto-Dimming Mirror Kit - Juke

### ⚠ CAUTION

- Exercise caution when removing and installing LH front pillar finisher due to side airbag placement. Reference Figure 9 below for further detail.
- Do **NOT** re-use LH front pillar finisher clips. LH front pillar finisher clips (P/N 76988 JM00A) **MUST** be replaced during re-installation of finisher.

- 5) Disengage driver side front pillar garnish fixing clip and metal clip with panel removal tool, cut clips with cutter knife and then remove front pillar garnish. **(Fig. 9)**

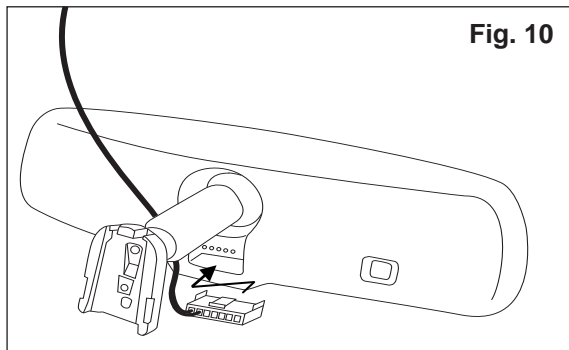
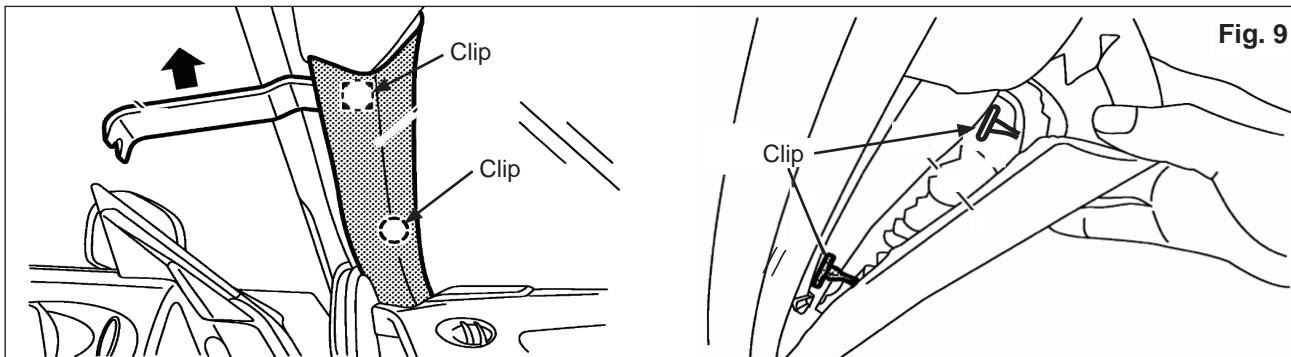

- 6) Install EC mirror

- a) Plug the EC mirror harness connector into the back of the EC mirror. **(Fig. 10)**

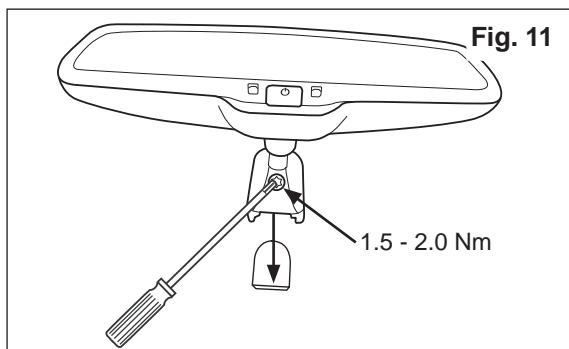

- b) Slide the EC mirror base over the button on the windshield.
- c) Using a T20 torx head driver, tighten the screw on the mirror mount to 1.5 - 20 Nm. **(Fig. 11)**

## Auto-Dimming Mirror Kit - Juke

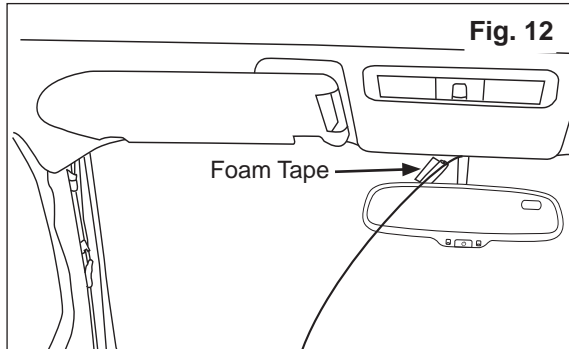

- d) Wrap 1 piece of foam tape around EC mirror harness and using panel removal tool, tuck between headliner and roof above EC mirror. **(Fig. 12)**

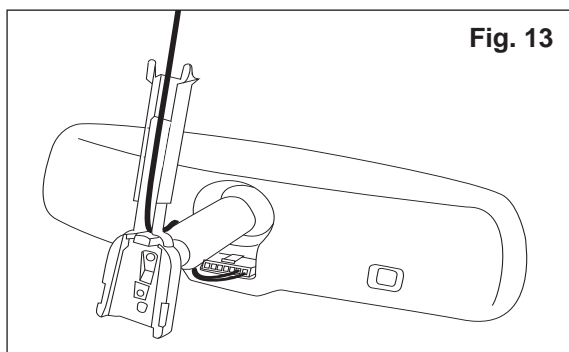

- e) Route the EC mirror harness into the groove of short wire cover (Item D) and attach to the mirror mount. **(Fig. 13)**
- f) Slide the forks on top of the wire cover, into the headliner so that the prongs of the wire cover are under headliner. **(Fig. 13)**

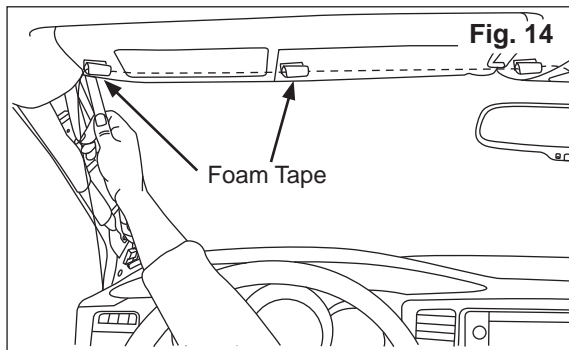

- g) Wrap 1 piece of foam tape around EC mirror harness at center of sun visor and where the headliner bends towards driver side door. **(Fig. 14)**
- h) Using panel removal tool, tuck the wire harness between the headliner and roof. **(Fig. 14)**

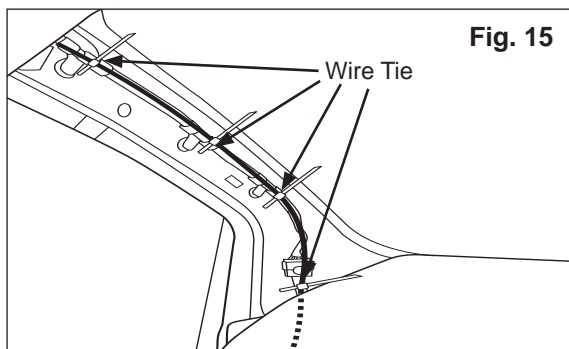

- i) Route EC mirror harness down driver side A-pillar and secure to existing vehicle harness with 4 wire ties. **(Fig. 15)**

## Auto-Dimming Mirror Kit - Juke

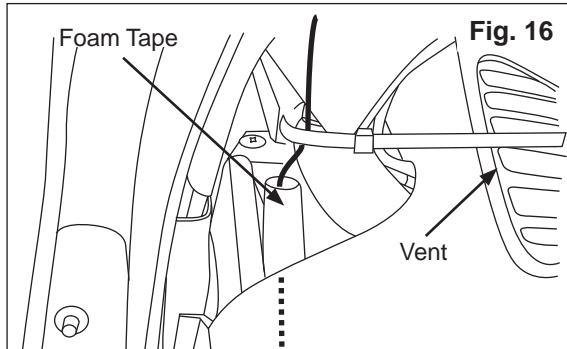

- j) Wrap 1 piece of foam tape around EC wire harness at the base of the A-pillar to protect harness from metal frame. **(Fig. 16)**

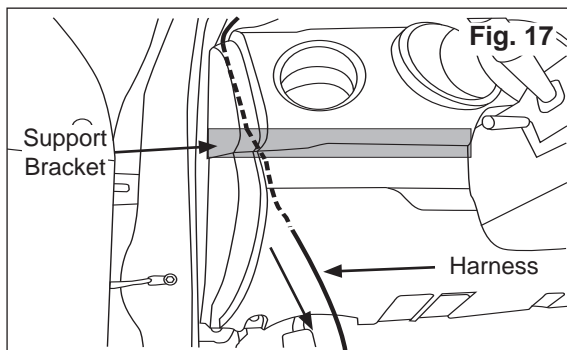

- k) Carefully route EC mirror harness through center dash panel, over the support bracket and down to the kick panel area. **(Fig. 17)**

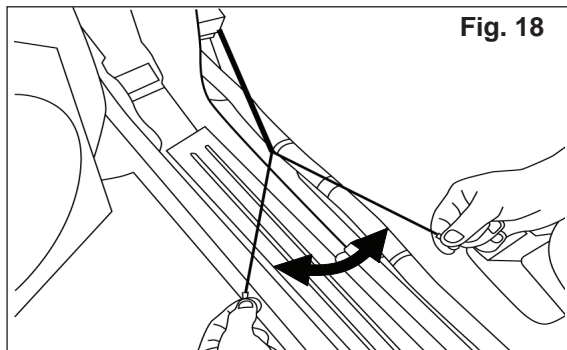

- l) Pull power and ground wires apart approximately 24 inches. **(Fig. 18)**

# Auto-Dimming Mirror Kit - Juke

## ⚠ CAUTION

- Color(s) given in illustration(s) are for reference only. Use location(s) where color deviates.
- If a vehicle wire is being used by another accessory and a posi-tap is present, tap the accessory wire NOT the vehicle wire.

- 7) Secure gray end of the wire tap to **Blue Wire**. (Fig. 19)
  - a) See steps 8 - 12 for wire tap installation instructions.
  - b) Locate Blue wire at back of J/B. (Fig. 19)

Fig. 19

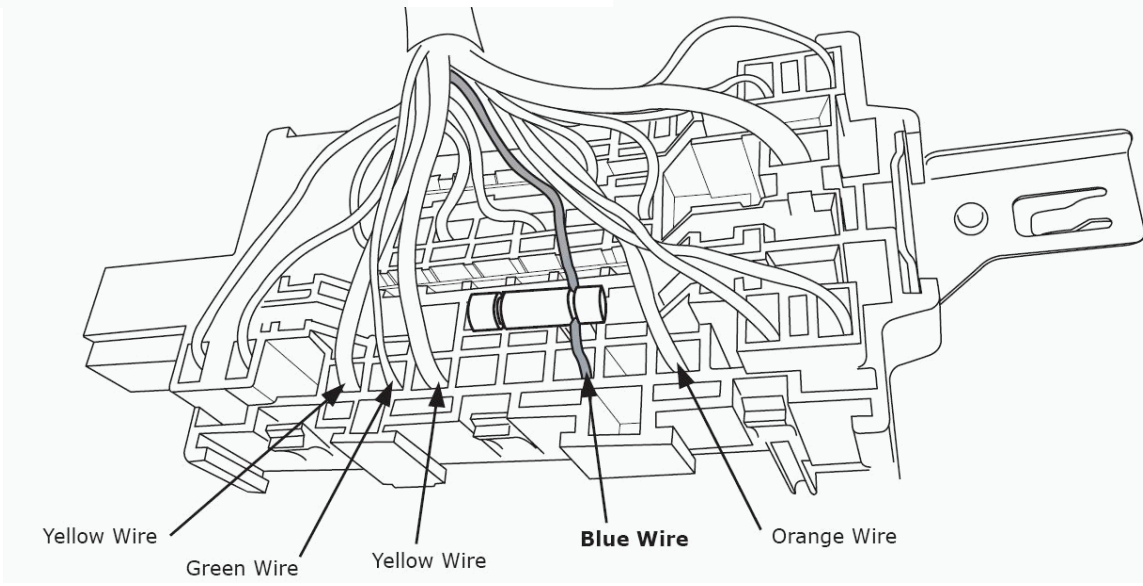
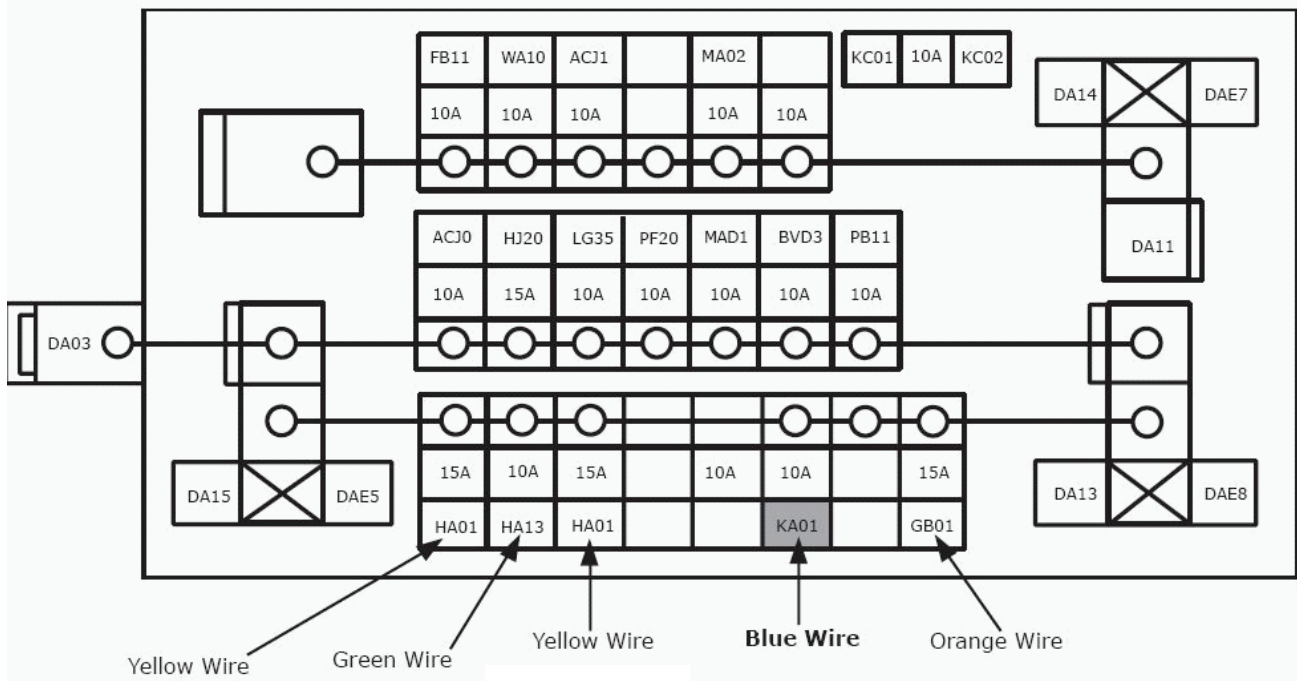

## Auto-Dimming Mirror Kit - Juke

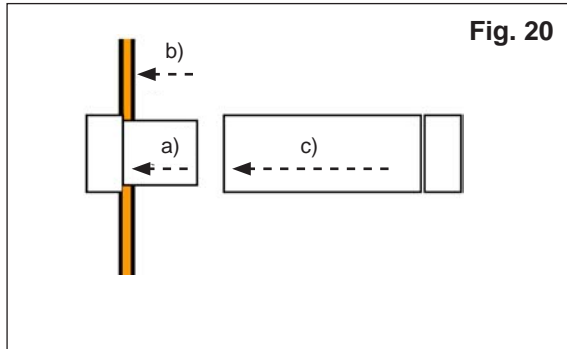

- 8) Tap vehicle wire. **(Fig. 20)**
- a) Remove cap (slot side) from tap body.
  - b) Slide the cap around vehicle wire.
  - c) Tighten the tap **TIGHT** with finger pressure.

**NOTE:**  
Do not re-use the tap for subsequent re-installation.

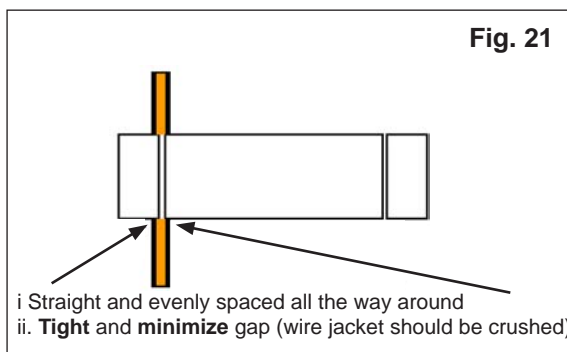

- 9) Inspect the tap to ensure correct installation. **(Fig. 21)**

**NOTE:**  
Avoid putting pressure on the vehicle wire and tap for the rest of the installation.

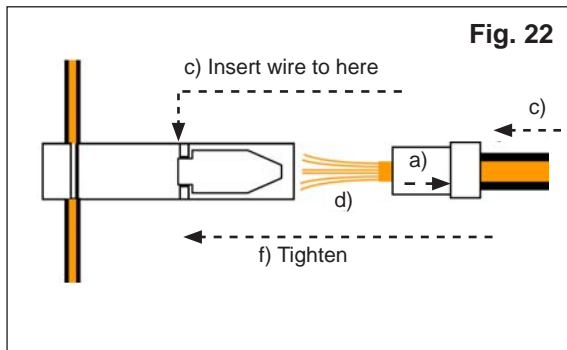

- 10) Tap accessory wire. **(Fig. 22)**
- a) Remove tap (non-pierce) side from tap.
  - b) Remove the protective stub.
  - c) Insert black wire **without** ground ring through the non-pierce side opening.
  - d) Spread the individual strands into fan shape.
  - e) Insert wire into the tap body and ensure that it is all the way in.
  - f) Tighten the tap **TIGHT** with finger pressure.

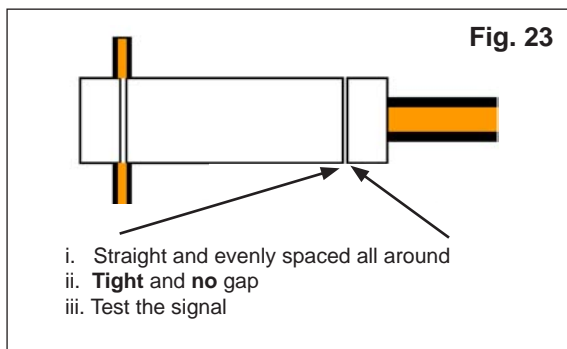

- 11) Confirm the tapped accessory wire **(Fig. 23)**
- a) Inspect the tap to ensure correct installation.
  - b) Test the signal to ensure that it is working properly.

**NOTE:**  
Avoid putting pressure on the vehicle wire, tap, and accessory wire for the rest of the installation.

## Auto-Dimming Mirror Kit - Juke

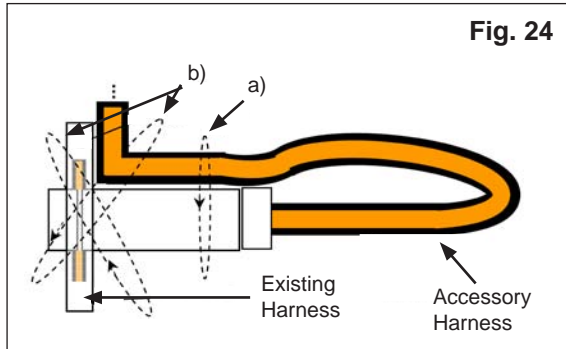

### 12) Secure the tap (**Fig. 24**)

- a) Secure the tapped wire on the non-pierce side to the body of the posi-tap with electrical tape (2 revolutions).
- b) Secure the body to harness where vehicle wire is being tapped with electrical tape (2 revolutions).

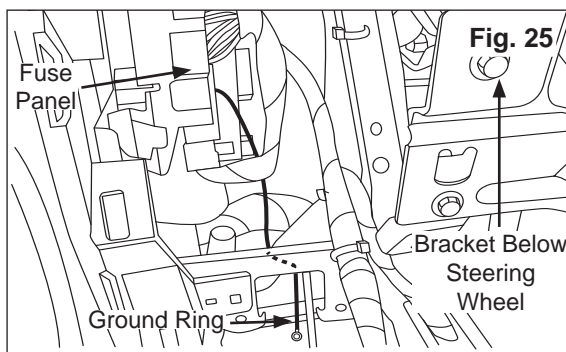

### 13) Install EC mirror ground ring to 10mm bolt near gas door lever.

- a) Begin by routing the ground ring portion of the mirror harness down to the hood release bolt location. Actual installation of ground ring will occur at a later step. (**Fig. 25**)

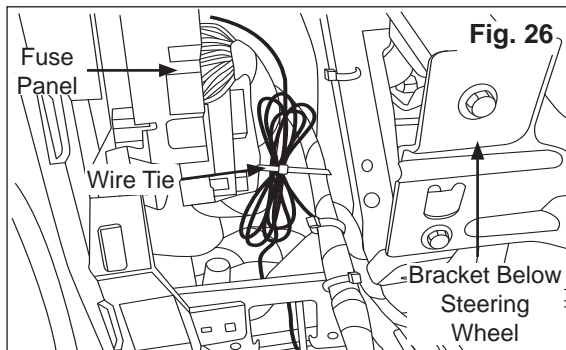

- b) Bundle excess mirror harness and secure to existing vehicle harness with 1 wire tie. Be sure to leave enough ground ring portion of the harness to extend to the hood release bolt location (which will be installed at a later step). (**Fig. 26**)
- c) Trim excess material off wire tie installed on previous step.

## Auto-Dimming Mirror Kit - Juke

### ⚠ CAUTION

- When stacking multiple ground eyelets, DO NOT stack the stems of the eyelet. **(Fig. 27)**
- When stacking multiple ground eyelets, leave a 30° spacing between stems of the eyelet. **(Fig. 28)**

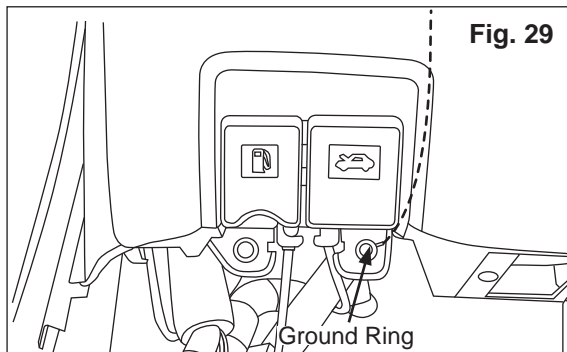
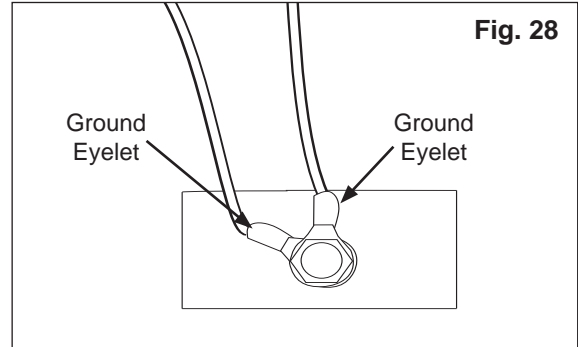
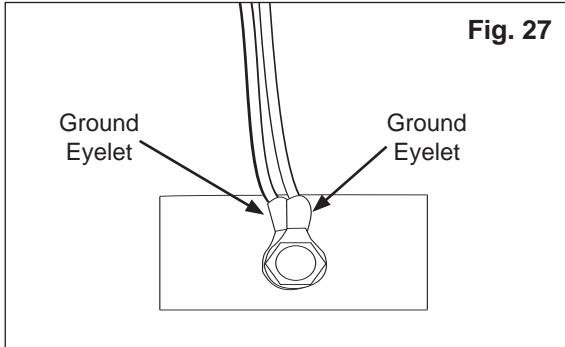

- d) Begin reinstalling driver side instrument lower panel. (Reference pages 3 - 4, sections 3a - 3d).
- e) During reinstallation, attach ring terminal from EC mirror harness over ground bolt for hood release lever and securely tighten bolt. **(Fig. 29)**

## Auto-Dimming Mirror Kit - Juke

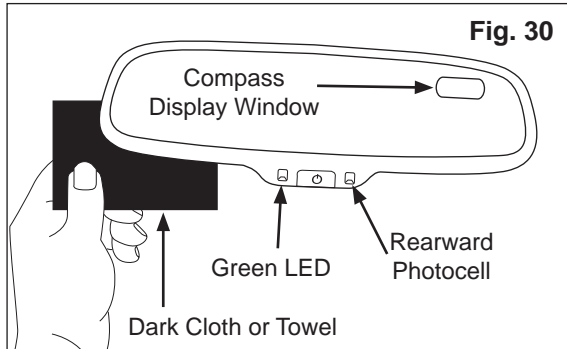

### 14) Testing (Fig. 30)

- a) Reconnect the vehicle's negative battery cable.
- b) Tighten negative battery terminal nut to 4.1 Nm.
- c) Turn the ignition switch to ON.
- d) Ensure vehicle is in a fairly well lit area.
- e) Check to see that green LED is illuminated. If it is not, press the "⏻" to turn it on.
- f) Cover the forward-looking photocell (located on the back of the mirror) with a dark cloth or towel. After a few seconds, the mirror should begin to darken. Timing will vary with ambient light levels and a flashlight may be shined on the rearward photocell if needed, to accelerate effect.
- g) Remove the cover from the forward-looking photocell and the mirror will begin to clear.
- h) Push the "⏻" button to ensure compass display shows either a direction such as "NE" or a "C", and that it can be turned ON and OFF.

### 15) Trim excess material off all wire ties.

### 16) Re-install the LH front pillar finisher

- a) Insert new clip's (P/N 76988 JM00A) into the finisher hole ensuring the long hook faces down. **(Fig. 31)**
- b) Insert the base of the finisher.
- c) Insert panel removal tool (A) between the front pillar finisher bottom side and body side and press clips into body. **(Fig. 32)**
- d) Push the finisher toward the vehicle body to attach.

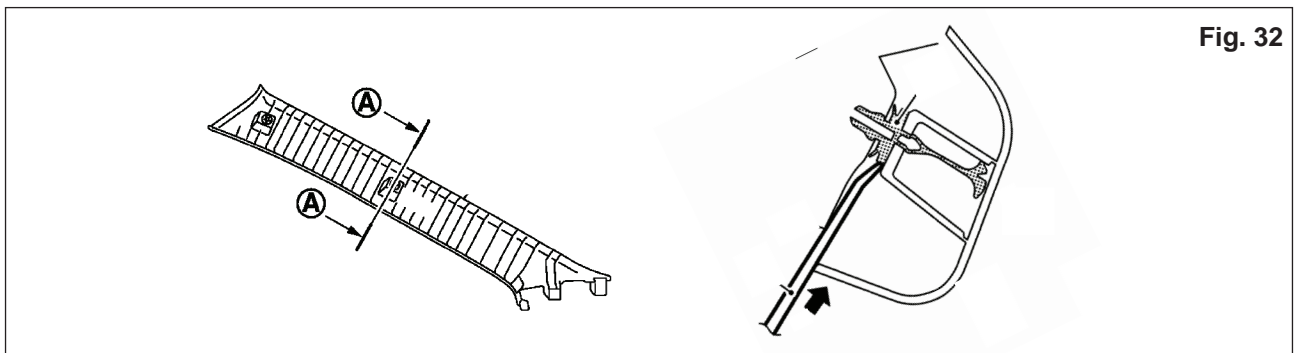
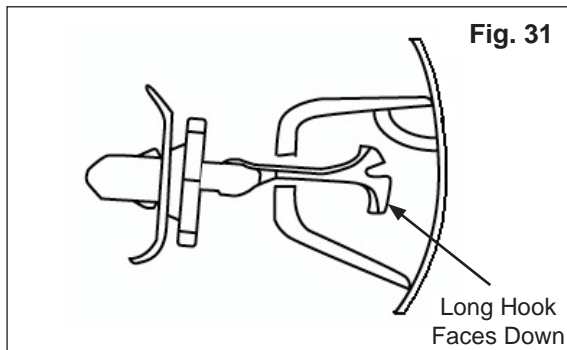

## Auto-Dimming Mirror Kit - Juke

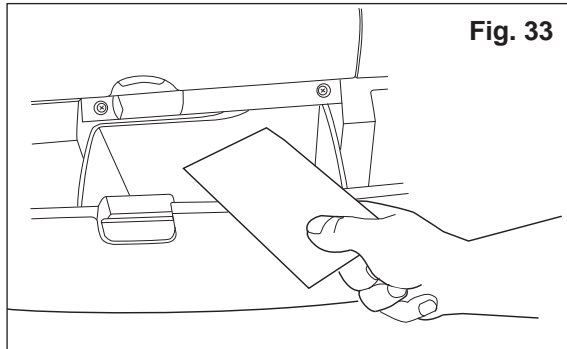

### 17) Final Assembly

- a) Reinstall in reverse order, all trim pieces removed during installation.
- b) Remove fingerprints, smudges, dirt, etc from mirror glass.
- c) Place the operation instruction card in the vehicle glovebox. **(Fig. 33)**
- d) Verify each reinstalled component for proper fit and function.
- e) Verify operation of all buttons disconnected during installation.

## ⚠ CAUTION

- Use caution when re-installing interior components to avoid damage, scratches, or breaking of mounting clips. Refer to the vehicle specific service manual for more information.



### 18) Set Compass Zone

- a) With the display turned "ON", push the "⏻" button for 3 seconds, until a number appears in display (numbers correspond to regional compass zones).
- b) Press and release "⏻" button to scroll through zone numbers.
- c) Release "⏻" button when correct zone number is displayed. Zone number will disappear and display will return to showing either a directional heading or a "C" after 5 seconds of no switch activity.

### 19) Calibrate Compass

- a) Drive vehicle in circles (360°) at 5 mph or less until compass display window shows a direction.

## Auto-Dimming Mirror Kit - Juke

### 9. Post Installation Check Sheet

- Inspect the vehicle interior and exterior for damage.
- Confirm proper operation of vehicle systems.
- Vehicle trim parts reinstalled in good fit and finish.
- Reset radio presets to the recorded settings.
- Start the Engine and check that the following vehicle functions are operational.
  - Power Mirror Switch
  - Traction Control Switch
  - AWD Switch (if equipped)

Posi-Tap™ is protected by patent # 5,228,875 5,695,369 5,868,589 6,692,313 Jap 2881414 Aus 708700  
Tia 103534 Can 2204826 Mex 200626 Korea 477279 China Z197105562.9 & others pending.