



User's Guide

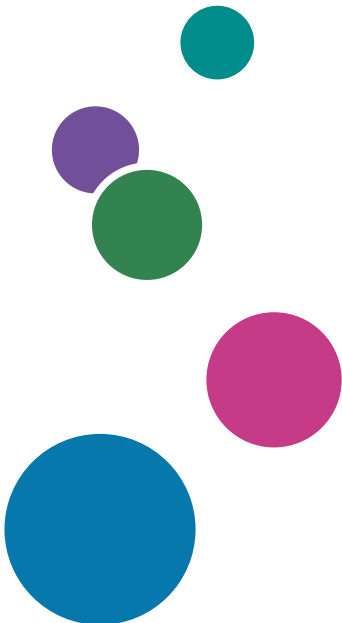

TABLE OF CONTENTS

How to Find Information about Operations and Troubleshooting.....	11
Operating Manual (Printed).....	11
Operating Manual (Digital Format).....	11
How to Read This Manual.....	13
Introduction.....	13
Symbols Used in This Manual.....	13
Model-Specific Information.....	13
Disclaimer.....	14
Notes.....	14
Note to Administrator.....	15
List of Option.....	15
About IP Address.....	16
1. Guide to the Machine	
Guide to Components.....	17
Exterior: Front View.....	17
Exterior: Rear View.....	19
Interior.....	21
Control Panel.....	22
Installing Option.....	25
Attaching Paper Feed Unit.....	25
How to Use the [Home] Screen.....	28
Displaying the [Home] Screen.....	28
How to Use the [Home] Screen.....	28
Customizing the [Home] Screen.....	31
How to Customize the [Home] Screen.....	31
Adding to the [Home] Screen Shortcuts to Favorite Items.....	31
Changing the Order of Icons on the [Home] Screen.....	31
Deleting an Icon on the [Home] Screen.....	32
Registering Frequently Used Functions.....	33
Registering Functions in a Favorite Item.....	33
Recalling a Favorite Item.....	34
Deleting a Favorite Item.....	35
Displaying Frequently Used Modes Preferentially.....	36

Multi-access.....	37
About Operation Tools.....	41
Entering Characters.....	42
Character Entry Display.....	42
Available Characters.....	43
Entering Text.....	43
Using RICOH Smart Device Connector.....	45
Connecting a Smart Device to the Machine Using NFC.....	46
Writing the Machine's Information to the NFC with a Smart Device.....	46
Using the Application on a Smart Device by Using NFC.....	46

2. Paper Specifications and Adding Paper

Workflow for Loading Paper and Configuring Paper Sizes and Types.....	47
Loading Paper.....	48
Loading Paper into Tray1 and 2.....	48
Loading Paper into Bypass Tray.....	53
Loading Envelopes.....	54
Specifying Paper Type and Paper Size Using the Control Panel.....	56
Specifying the Paper Type.....	56
Specifying the Standard Paper Size.....	57
Specifying a Custom Paper Size.....	57
Specifying Paper Type and Paper Size Using Web Image Monitor.....	59
Specifying a Custom Paper Size.....	59
Specifying Paper Type and Paper Size Using the Printer Driver.....	60
When Using Windows.....	60
When Using OS X/macOS.....	61
Supported Paper.....	62
Specifications of Paper Types.....	65
Non-Recommended Paper Types.....	72
Paper Storage.....	72
Print Area.....	73
Placing Originals.....	76
Placing Originals on the Exposure Glass.....	76
Placing Originals in the Auto Document Feeder.....	76

About Originals.....	77
----------------------	----

3. Printing Documents

What You Can Do with the Printer Function.....	81
Configuring Option Settings for the Printer.....	82
Conditions for Bidirectional Communication.....	82
If Bidirectional Communication is Disabled.....	82
Displaying the Printing Preferences Dialog Box.....	85
Displaying the Printing Preferences Dialog Box from the [Start] Menu.....	85
Displaying the Printing Preferences Dialog Box in an Application.....	85
Basic Operation of Printing.....	87
When Using Windows.....	87
When Using macOS/OS X.....	87
If a Paper Mismatch Occurs.....	88
Canceling a Print Job.....	89
Printing Confidential Documents.....	91
Storing a Locked Print file.....	91
Printing a Locked Print file.....	92
Deleting a Locked Print file.....	93
Using Various Print Functions.....	95
Print Quality Functions.....	95
Print Output Functions.....	96

4. Copying Originals

What You Can Do with the Copier Function.....	99
Copier Mode Screen.....	100
Basic Operation of Copying.....	102
Canceling a Copy.....	103
Making Enlarged or Reduced Copies.....	105
Specifying Reduce/Enlarge.....	106
Copying Single-Sided Originals with 2-Sided and Combined Printing.....	107
Specifying Combined and 2-sided Copies.....	110
Copying 2-Sided Originals with 2-Sided and Combined Printing.....	112
Duplex Copying Using the ADF.....	113
Duplex Copying Manually Using the Exposure Glass.....	115

Copying an ID Card.....	117
Specifying Scan Settings for Copying.....	120
Adjusting Image Density.....	120
Selecting the Document Type According to Original.....	120

5. Scanning Originals

What You Can Do with the Scanner Function.....	123
Scanner Mode Screen.....	124
Registering Scan Destinations.....	126
Modifying Scan Destinations.....	132
Deleting Scan Destinations.....	132
Testing Transmission.....	133
Basic Operation of Scan to Folder.....	135
1 Printing the Check Sheet.....	135
2 Confirming the User Name and Computer Name.....	136
3 Creating a Shared Folder on a Computer.....	138
4 Specifying Access Privileges for the Created Shared Folder.....	140
5 Registering a Shared Folder in the Machine's Address Book.....	140
6 Send Scanned Files to a Shared Folder.....	141
Basic Operation of Scan to E-mail.....	144
1 Configuring SMTP and DNS Settings.....	144
2 Registering Destination E-mail Addresses to the Address Book.....	145
3 Sending Scanned Files by E-mail.....	145
Basic Operation of Scan to FTP.....	148
1 Configuring FTP Server Settings.....	148
2 Sending Scanned Files to an FTP Server.....	148
Specifying the Scan Destination Using [Resend].....	151
Basic Procedures for Saving Scan Files on a USB Flash Memory Device.....	152
Basic Operation for RICOH Scan Utility V2.....	155
Preparations for Using RICOH Scan Utility V2.....	155
Using RICOH Scan Utility V2 to Scan to a Computer.....	155
Basic Operation for TWAIN Scanning.....	159
Using TWAIN scanner.....	159
TWAIN scanning.....	159

Settings you can configure in the TWAIN dialog box.....	160
Basic Operation for WIA Scanning.....	162
Basic Operation for ICA Scanning.....	163
Installing the ICA Driver.....	163
Using ICA Scanner.....	163
ICA Scanning.....	163
Settings you can configure in the ICA dialog box.....	164
Using SANE scanning.....	166
Specifying Scan Settings for Scanning.....	167
Specifying the Scanning Size According to the Size of the Original.....	167
Adjusting Image Density.....	168
Specifying Resolution.....	169

6. Sending and Receiving a Fax

What You Can Do with the Fax Function.....	171
Fax Setting Workflows.....	172
Fax Mode Screen.....	173
Setting the Date and Time.....	175
Registering Fax Destinations.....	176
Registering Fax Destinations Using the Control Panel.....	176
Registering Fax Destinations Using Web Image Monitor.....	178
Preventing Transmission to the Wrong Destination.....	180
Sending a Fax.....	182
Selecting Transmission Mode.....	182
Internet Fax Transmission.....	183
Basic Operation for Sending a Fax.....	184
Canceling a Transmission.....	186
Specifying the Fax Destination.....	188
Useful Sending Functions.....	191
Specifying Scan Settings for Faxing.....	193
Using the Fax Function from a Computer (LAN-Fax).....	196
Basic Operation for Sending Faxes from a Computer.....	196
Configuring Transmission Settings.....	198
Configuring the LAN-Fax Address Book.....	198

Editing a Fax Cover Sheet.....	201
Receiving a Fax.....	202
Selecting Reception Mode.....	202
Receiving an Internet Fax.....	206
Forwarding or Storing Faxes in Memory.....	208
Receiving or Rejecting Faxes from Special Senders.....	212
Lists/Reports Related to Fax.....	214

7. Configuring the Machine Using the Control Panel

Basic Operation.....	215
Menu Chart.....	216
Copier Settings.....	217
Scanner Settings.....	222
Fax Settings.....	224
Address Book.....	233
System Settings.....	234
Printer Settings.....	242
Paper Settings.....	246
Administrator Tools Settings.....	251
Printing Lists/Reports.....	259
Printing the Configuration Page.....	259
Types of Lists/Reports.....	259
Network Settings.....	261
@Remote.....	266

8. Configuring the Machine Using Utilities

Available Setting Functions Using Web Image Monitor.....	267
Using Web Image Monitor.....	268
Displaying Top Page.....	269
Changing the Interface Language.....	270
Checking the System Information.....	271
Status Tab.....	271
Counter Tab.....	272
Machine Information Tab.....	275
Configuring the System Settings.....	276

Sound Volume Adjustment Tab.....	276
Tray Paper Settings Tab.....	276
Copier Tab.....	280
Fax Tab.....	280
Priority Tray Tab.....	282
Toner Saving Tab.....	283
I/O Timeout Tab.....	284
Black-and-White Print Priority Tab.....	284
Registering Destinations.....	285
Registering Fax Special Senders.....	286
Restricting Machine Functions According to User.....	287
Enabling the User Restriction Settings.....	287
When Machine Functions are Restricted.....	291
Configuring the Network Settings.....	293
Network Status Tab.....	293
IPv6 Configuration Tab.....	294
Network Application Tab.....	294
DNS Tab.....	295
Auto E-mail Notification Tab.....	296
SNMP Tab.....	297
SMTP Tab.....	298
POP3 Tab.....	299
Internet Fax Tab.....	299
Wireless Tab.....	300
Certificate Tab.....	302
Configuring the IPsec Settings.....	304
IPsec Global Settings Tab.....	304
IPsec Policy List Tab.....	304
Printing Lists/Reports.....	308
Configuring the Administrator Settings.....	309
Administrator Tab.....	309
Reset Settings Tab.....	309
Backup Setting Tab.....	310

Restore Setting Tab.....	311
Set Date/Time Tab.....	311
Energy Saver Mode Tab.....	312

9. Maintaining the Machine

Replacing the Print Cartridge.....	313
Replacing the Waste Toner Bottle.....	318
Replacing a Component.....	324
Replacing the Intermediate Transfer Unit.....	324
Replacing the Fusing Unit and Transfer Roller.....	324
Cautions When Cleaning.....	325
Cleaning the Toner Density Sensor.....	326
Cleaning the Friction Pad and Paper Feed Roller.....	328
Cleaning the Registration Roller and Paper Tray.....	331
Cleaning the Exposure Glass.....	334
Cleaning the Auto Document Feeder.....	335
Moving and Transporting the Machine.....	337
Disposal.....	338
Where to Inquire.....	338

10. Troubleshooting

Error and Status Messages on the Screen.....	339
Removing Paper Jams.....	349
Removing Printing Jams.....	349
Removing Scanning Jams.....	357
When You Cannot Print Test Page.....	359
Paper Feed Problems.....	360
Print Quality Problems.....	363
Checking the Condition of the Machine.....	363
Checking the Printer Driver Settings.....	364
Printer Problems.....	366
When You Cannot Print Properly.....	366
When You Cannot Print Clearly.....	370
When Paper Is Not Fed or Ejected Properly.....	374
Other Printing Problems.....	375



Copier Problems.....	376
When You Cannot Make Clear Copies.....	376
When You Cannot Make Copies as Wanted.....	377
Scanner Problems.....	378
When You Cannot Browse the Network to Send a Scan File.....	378
When Scanning Is Not Done As Expected.....	378
Fax Problems.....	379
When You Cannot Send or Receive Fax Messages As Wanted.....	379
When an Error Is Notified via a Report or E-mail.....	382
Error Code.....	384
Common Problems.....	389

11. Configuring Network Settings

Connecting the Machine to a Wired Network.....	391
Configuring the IPv4 Setting.....	391
Configuring the IPv6 setting.....	391
Connecting the Machine to a Wireless Network.....	393
Using the Wi-Fi Setup Wizard.....	393
Using the WPS Button.....	394
Using a PIN Code.....	396

12. Appendix

Transmission Using IPsec.....	399
Encryption and Authentication by IPsec.....	399
Security Association.....	400
Encryption Key Exchange Settings Configuration Flow.....	401
Specifying Encryption Key Exchange Settings.....	401
Specifying IPsec Settings on the Computer.....	402
Enabling and Disabling IPsec Using the Control Panel.....	404
Notes About the Toner.....	406
Specifications of the Machine.....	407
General Function Specifications.....	407
Printer Function Specifications.....	409
Copier Function Specifications.....	410
Scanner Function Specifications.....	411

Fax Function Specifications.....	412
Paper Feed Unit TK1220.....	414
Consumables.....	416
Print Cartridge.....	416
Waste Toner Bottle.....	417
Information for This Machine.....	418
User Information on Electrical & Electronic Equipment  Region A (mainly Europe and Asia).....	418
Note for the Battery and/or Accumulator Symbol (For EU countries only).....	419
Environmental Advice for Users  Region A (mainly Europe).....	419
Note to Users EU Countries.....	420
NOTES TO USERS REGARDING FACSIMILE UNIT (NEW ZEALAND).....	421
Notes to users in the state of California (Notes to Users in USA).....	421
Notes to users in the United States of America.....	422
Notes to Canadian Users of Wireless Devices.....	424
Notes to Canadian Users regarding Facsimile Unit.....	425
ENERGY STAR Program  Region B	426
Saving Energy.....	426
Trademarks.....	429
INDEX	431

How to Find Information about Operations and Troubleshooting

You can find support information about operating the machine and troubleshooting in the Operating Manual (printed), Operating Manual (digital format), and Help (online).

Operating Manual (Printed)

The following manuals are provided with this machine.

Safety Information

This manual explains the safety precautions that should be followed when using the machine. Be sure to read this manual before using the machine.

Setup Guide

This manual explains how to set up the machine. It also explains how to remove the machine from the packaging and how to connect it to a computer.

Operating Manual (Digital Format)

Operating manuals can be viewed from Ricoh's website or from the provided CD-ROM.

Viewing from a web browser

Access the Internet from a web browser.

Confirm that the computer or the machine is connected to the network.

Download the operating manuals from <https://www.ricoh.com/>.

Viewing from the provided CD-ROM

Operating manuals can also be viewed from the provided CD-ROM.

- When using Windows

1. Insert the CD-ROM into the CD-ROM drive.
2. Click [Read Manual] and follow the instructions on the screen.

The PDF file manual opens.

- When using OS X/macOS

1. Insert the CD-ROM into the CD-ROM drive.
2. Double-click **Manuals.htm** file, located on the CD-ROM root directory.
3. Select the language.
4. Click [Read PDF manuals].

5. Click the manual you want to refer to.

The PDF file manual opens.

How to Read This Manual

Introduction

This manual contains detailed instructions and notes on the operation and use of this machine. For your safety and benefit, read this manual carefully before using the machine. Keep this manual in a handy place for quick reference.

Symbols Used in This Manual

This manual uses the following symbols:

★ Important

Indicates points to pay attention to when using functions. This symbol indicates points that may result in the product or service becoming unusable or result in the loss of data if the instructions are not obeyed. Be sure to read these explanations.

↓ Note

Indicates supplementary explanations of the product's functions and instructions on resolving user errors.

[]

Indicates the names of keys on the machine's display or control panels.

Model-Specific Information

This section explains how you can identify the region your machine belongs to.

There is a label on the rear of the machine, located in the position shown below. The label contains details that identify the region your machine belongs to. Read the label.

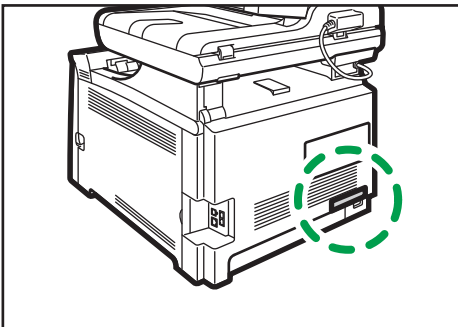

ECC101

The following information is region-specific. Read the information under the symbol that corresponds to the region of your machine.

 **Region A** (mainly Europe and Asia)

If the label contains the following, your machine is a region A model:

- CODE XXXX -27
- 220–240 V

 **Region B** (mainly North America)

If the label contains the following, your machine is a region B model:

- CODE XXXX -17
- 120–127 V

 **Note**

- Dimensions in this manual are given in two units of measure: metric and inch. If your machine is a Region A model, refer to the metric units. If your machine is a Region B model, refer to the inch units.

Disclaimer

To the maximum extent permitted by applicable laws, in no event will the manufacturer be liable for any damages whatsoever arising out of failures of this machine, losses of the registered data, or the use or non-use of this product and operation manuals provided with it.

Make sure that you always copy or have backups of the data registered in this machine. Documents or data might be erased due to your operational errors or malfunctions of the machine.

In no event will the manufacturer be responsible for any documents created by you using this machine or any results from the data executed by you.

Notes

Contents of this manual are subject to change without prior notice.

Two kinds of size notation are employed in this manual.

Some illustrations in this manual might be slightly different from the machine.

Certain options might not be available in some countries. For details, please contact your local dealer.

Depending on which country you are in, certain units may be optional. For details, please contact your local dealer.

For good output quality, the manufacturer recommends that you use genuine toner from the manufacturer.

The manufacturer shall not be responsible for any damage or expense that might result from the use of parts other than genuine parts from the manufacturer with your office products.

Note to Administrator

Password

Certain configurations of this machine can be password-protected to prevent unauthorized modifications by others. We strongly recommend you to create your own password immediately.

The following are the operations that can be password-protected:

- Entering the [Address Book], [Network Settings], or [Administrator Tools] menu using the control panel

You can access these menus without a password by factory default.

The setting for creating a password can be found in [Administrator Tools].

- Configuring the [System Settings], [Quick Dial Destination], [Scan Destination], [Fax Speed Dial Destination], [Special Sender], [Restrict Available Functions], [Network Settings], [IPsec Settings], or [Administrator Tools] menu using Web Image Monitor

You can configure the machine using Web Image Monitor without a password by factory default.

The setting for creating a password can be found in [Administrator Settings].

For details about creating passwords, see page 309 "Configuring the Administrator Settings".

User Restriction

You can restrict the use of certain functions of this machine to users with proper authentication.

Using Web Image Monitor, you can select the functions you want to restrict, and register the users who can use that function upon authentication.

Note

- For details about creating passwords and configuring the user restriction settings, see page 287 "Restricting Machine Functions According to User".

List of Option

Option List	Referred to as
Paper Feed Unit TK1220	Paper feed unit

Note

- If Paper feed unit is attached, "Tray 2" appears on the machine's control panel.

About IP Address

In this manual, "IP address" covers both IPv4 and IPv6 environments. Read the instructions that are relevant to the environment you are using.

1. Guide to the Machine

This chapter describes preparations for using the machine and its operating instructions.

Guide to Components

This section introduces the names of the various parts on the front and rear side of the machine and outlines their functions.

Exterior: Front View

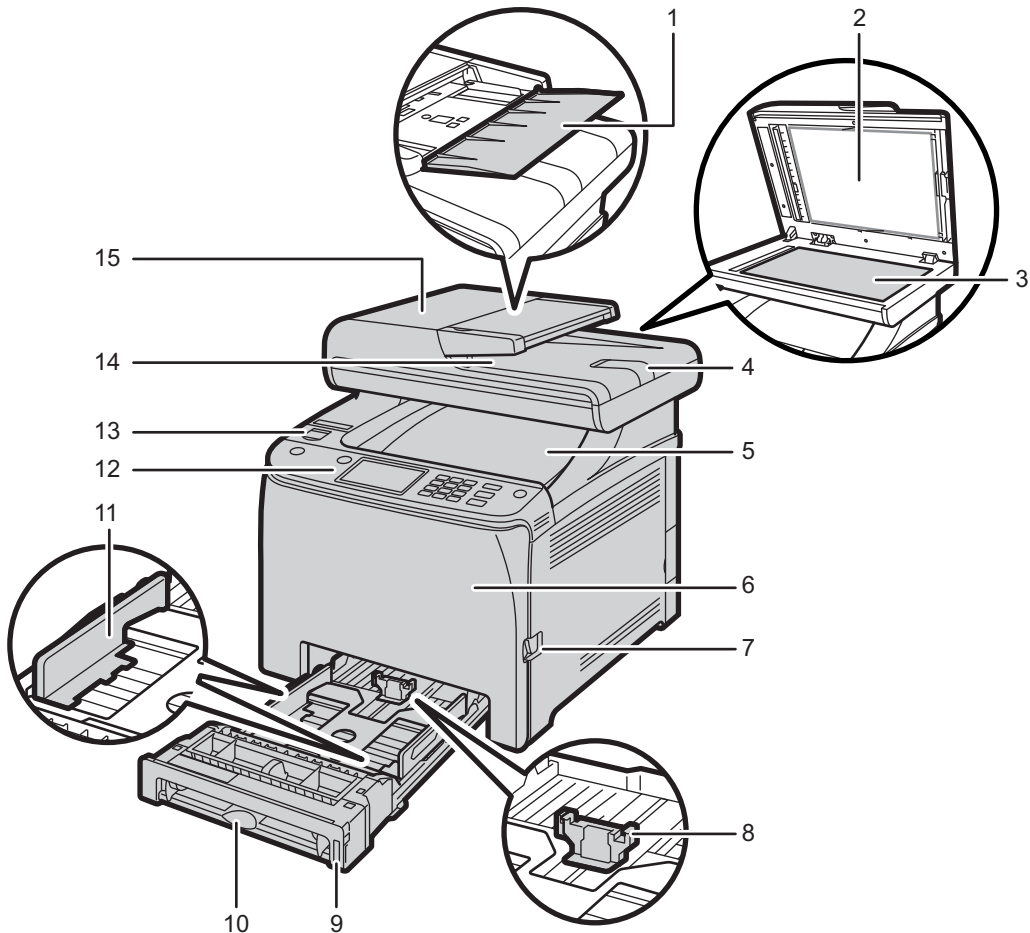

ECC102

No.	Name	Description
1	Input Tray for the ADF (Auto document feeder)	Place stacks of originals here. They will feed in automatically. This tray can hold up to 50 sheets of plain paper.
2	Auto Document Feeder (Exposure Glass Cover)	The ADF is integrated with the exposure glass cover. Open this cover to place originals on the exposure glass.
3	Exposure Glass	Place originals here sheet by sheet.
4	Extender for the ADF Tray	Extend these when placing paper longer than A4 in the input tray for ADF.
5	Standard Tray/Top Cover	Printed paper is delivered to this tray. Up to 150 sheets of plain paper can be stacked here. Open this to replace the print cartridges.
6	Front Cover	Open this cover to replace the waste toner bottle or remove jammed paper.
7	Front Cover Open Lever	To open the front cover, pull this lever on the right side of the machine.
8	End Fence	Adjust this fence to the paper size.
9	Tray 1	This tray can hold up to 250 sheets of plain paper.
10	Bypass Tray	Load paper here sheet by sheet.
11	Side Fence	Adjust this fence to the paper size.
12	Control Panel	Contains a screen and keys for machine control.
13	USB Flash Disk Port	Insert a USB flash disk for using the Scan to USB function.
14	Output Tray for the ADF	Originals scanned with the ADF are delivered from here.
15	ADF Cover	Open this cover to remove originals jammed in the ADF.

Exterior: Rear View

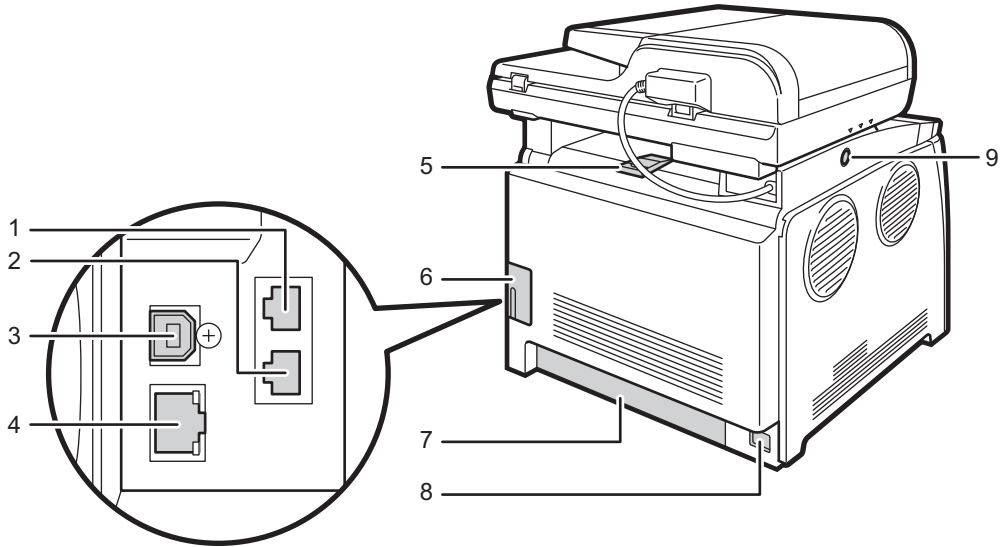

ECC103

No.	Name	Description
1	G3 (analog) Line Interface Connector	For connecting a telephone line.
2	External Telephone Connector	For connecting an external telephone.
3	USB Port	For connecting the machine to a computer using a USB cable.
4	Ethernet Port	For connecting the machine to the network using a network interface cable.
5	Stop Fences	Pull up this fence to prevent paper falling off when printing a large amount of paper at a time. The fence can be adjusted at the A4/Letter or Legal size position.
6	Cable Cover	Remove this cover when connecting cables to the machine.
7	Rear Cover	Remove this cover when loading paper longer than A4 in Tray 1.

No.	Name	Description
8	Power Socket	For connecting the power cord to the machine.
9	Button for Sliding the ADF	Press to slide the ADF towards the rear of the machine and hold it in that position, if paper output to the output tray is difficult to retrieve.

Note

- As shown, slide the ADF while pressing the button for sliding the ADF. Be sure to check that the ADF is closed in advance. Be careful not to trap your fingers when sliding.

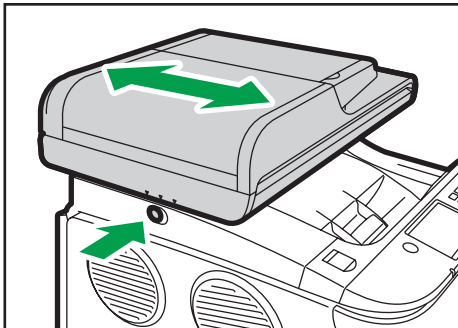

DUE205

- Pull up the retainer as shown below to prevent A4- or Letter-size printed copies from falling off.

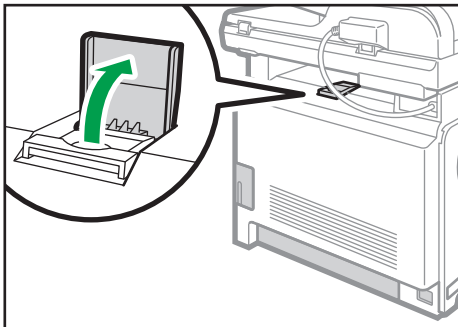

ECC104

- Pull up the retainer as shown below to prevent Legal-size printed copies from falling off.

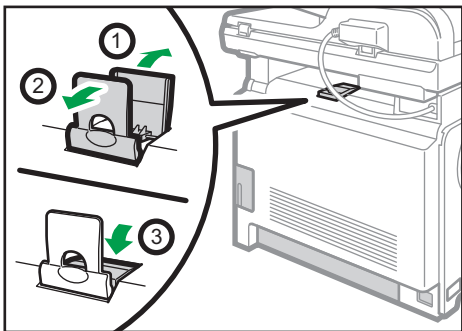

ECC105

Interior

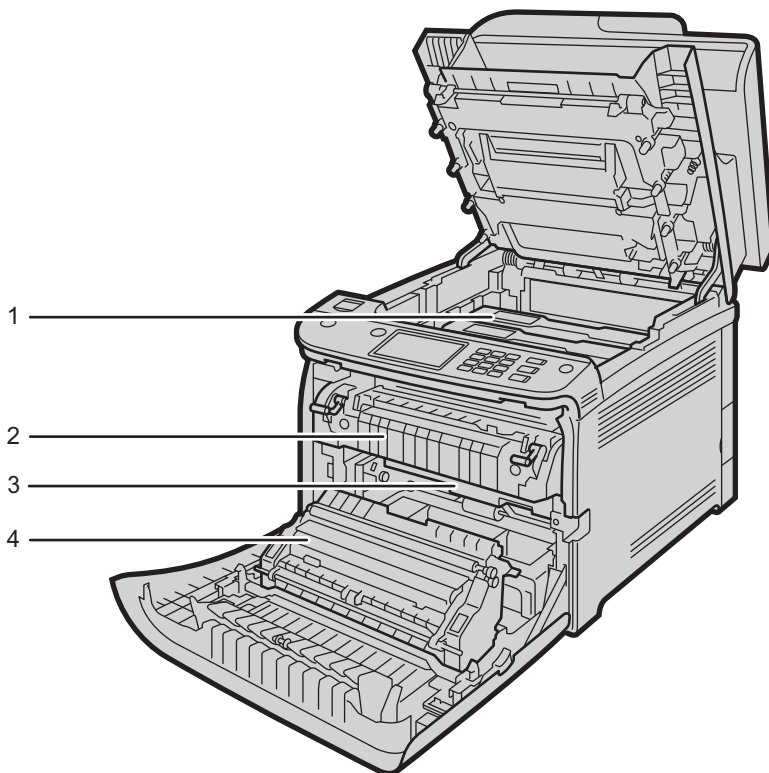

ECC106

No.	Name	Description
1	Print Cartridge	Install the print cartridges from the machine rear, in the order of cyan (C), magenta (M), yellow (Y), and black (K). Messages appear on the screen when print cartridges need to be replaced, or new ones need to be prepared.
2	Fusing Unit	Fuses toner to the paper. You might have to move this unit to check for or remove jammed paper.
3	Waste Toner Bottle	Collects toner that is wasted during printing.
4	Transfer unit	You need to remove this when you replace the waste toner bottle.

↓ Note

- For details about the messages that appear on the screen when consumables need to be replaced, see page 339 "Error and Status Messages on the Screen".

Control Panel

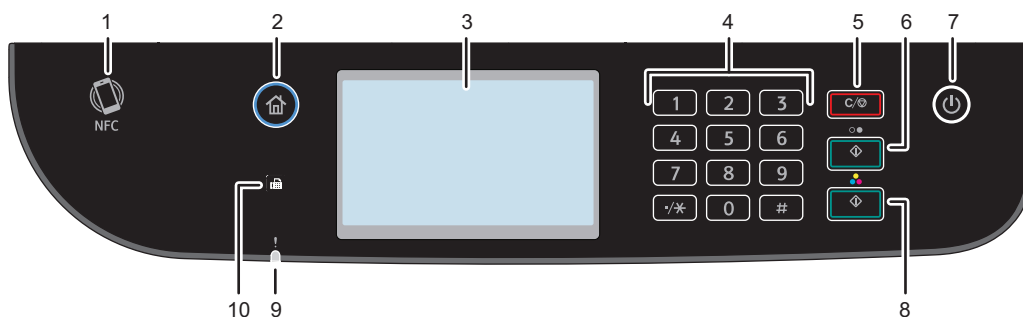

ECC201

No.	Name	Description
1	NFC	Allows you to connect a smart device to the machine when you touch NFC on a smart device using the application corresponding to the machine.
2	[Home] key	Press to display the [Home] screen. For details, see page 28 "How to Use the [Home] Screen".

No.	Name	Description
3	Display panel	<p>This is a touch panel display that features icons, keys, and shortcuts that allow you to navigate the screens of the various functions and provide you with information about operation status and other messages.</p> <p>You can display the software keyboard by double tapping the entry area on the display.</p>
4	Number keys	Use to enter the numbers for copies, fax numbers and data for the selected function.
5	[Clear/Stop] key	<ul style="list-style-type: none"> • While the machine is processing a job: press to cancel the current job. • While configuring the machine settings: press to cancel the current setting and return to standby mode. • While in standby mode: press to cancel temporary settings such as image density or resolution.
6	[B&W Start] key	Press to scan or copy in black and white, or start sending a fax.
7	[Power] key	<p>Press to turn on and turn off the main power. To turn off the machine, press and hold down this key for at least three seconds. This indicator lights up blue when the machine is turned on.</p> <p>If the machine's system is busy, the power may not be turned off even though you press and hold down this key for three seconds. If this is the case, press and hold down the [Clear/Stop] key and [Power] key simultaneously for at least three seconds to force the machine to turn off.</p> <p>Do not accidentally press the [Power] key within 3 minutes of disconnecting the power cord.</p>
8	[Color Start] key	Press to scan or copy in color.
9	Alert indicator	<p>Flashes yellow when the machine will require maintenance soon (such as replacing consumables), or lights up red when a machine error occurs.</p> <p>When an alert is issued, check the messages on the screen. For details about the messages that appear on the screen, see page 339 "Error and Status Messages on the Screen".</p>

No.	Name	Description
10	Fax indicator	Indicates the status of the fax functions. Lights up when received faxes that have not been printed out exist in the machine's memory. Flashes when the machine is unable to print out the faxes due to machine errors such as an empty paper tray or a paper jam.

Note

- The backlight of the screen is turned off when the machine is in Energy Saver mode.
- When the machine is processing a job, you cannot display the menu for configuring the machine. You can confirm the machine's status by checking messages on the screen. If you see messages such as "Printing...", "B&W Copying...", "Color Copying...", or "Processing...", wait until the current job is finished.

Installing Option

This section explains how to install options.

1

Attaching Paper Feed Unit

WARNING

- Touching the prongs of the power cable's plug with anything metallic constitutes a fire and electric shock hazard.
- It is dangerous to handle the power cord plug with wet hands. Doing so could result in electric shock.

CAUTION

- Before installing or removing options, always disconnect the power cord plugs from the wall outlet and allow time for the main unit to fully cool. Failing to take these precautions could result in burns.
- The machine weighs approximately 30 kg (67 lb.). When moving the machine, use the inset grips on both sides, and lift slowly in pairs.
- Lifting the paper feed unit carelessly or dropping may cause injury.
- Before moving the machine, unplug the power cord from the wall outlet. If the cord is unplugged abruptly, it could become damaged. Damaged plugs or cords can cause an electrical or fire hazard.

Important

- Tray 1 is required to print using the optional paper feed unit. Without Tray 1, paper jams will occur.
- The machine must be lifted by two people.
- Do not hold the tray to lift the machine.

1. Confirm that the following is true: The machine's cord is unplugged from the wall outlet.

2. Remove the adhesive tape from the optional paper feed unit.

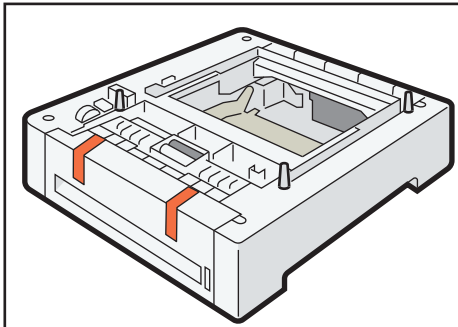

DPP210

3. Standing at the front and back of the machine, two persons should lift the machine using the inset grips on the sides.

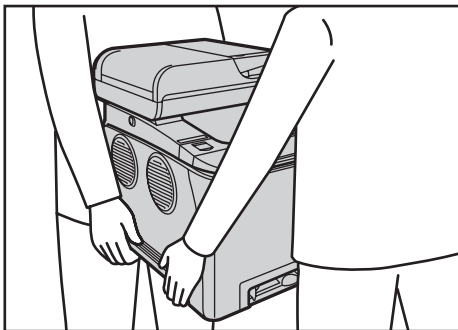

DUE287

4. There are three upright pins on the optional paper feed unit. Align the holes of the machine with the pins, and then lower the machine slowly.

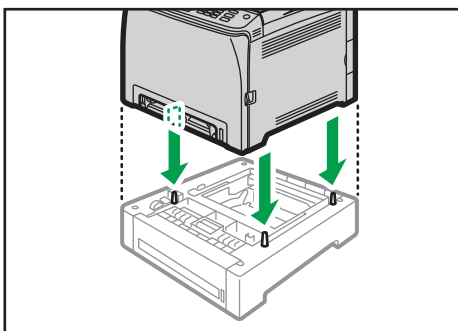

ECC107

5. Plug the machine's cord back into the wall outlet, and then turn on the power.

Note

- After installing the optional paper feed unit, select Tray 2 in the printer driver. For details, see the printer driver Help.
- If the new device is listed in the column of configuration options, it has been properly installed.

- If the optional paper feed unit is not installed properly, try to install it again by repeating the procedure. If the problem persists, contact your sales or service representative.
- For details about printing the configuration page, see page 259 "Printing Lists/Reports".

How to Use the [Home] Screen

↓ Note

- The [Home] screen is set as the default screen when the machine is turned on. You can change this default setting under Function Priority. See page 251 "Administrator Tools Settings".

Displaying the [Home] Screen

1. Press the [Home] key.

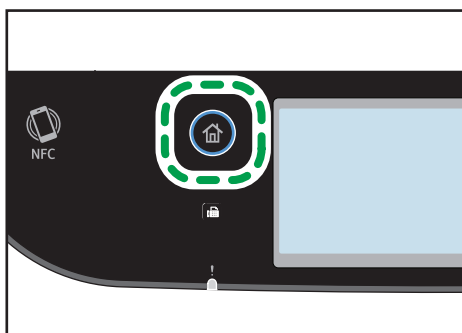

↓ Note

- Function or shortcut icons will be displayed on the [Home] screen. For details, see page 28 "How to Use the [Home] Screen".
- To use a different function, press the icon of the function you want to use.

How to Use the [Home] Screen

The icons of each function are displayed on the [Home] screen.

You can add shortcuts to favorite items to [Home] screens 2 and 3. The icons of added shortcuts appear on the [Home] screen. You can recall favorite items by pressing the shortcut icons.

To display the [Home] screen, press the [Home] key.

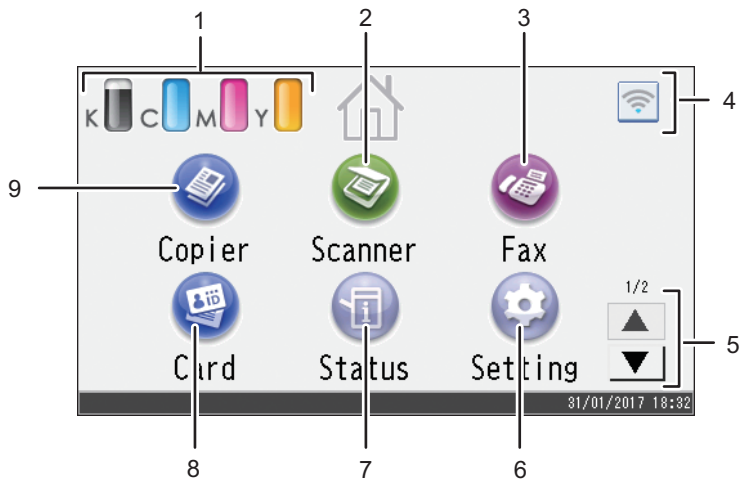
[Home] screen 1

DUE303

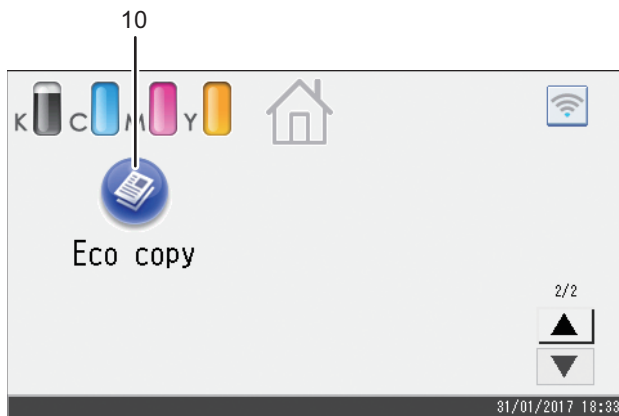
[Home] screen 2

DUE304

1. Supply Information icon

Displays the remaining amount of toner.

2. [Scanner] 

Press to scan originals and save images as files.

For details about how to use the scanner function, see page 123 "Scanning Originals".

3. [Fax] 

Press to send or receive faxes.

For details about how to use the fax function, see page 171 "Sending and Receiving a Fax".

4. Wireless LAN icon

Press to display the [Wi-Fi Configuration] screen.

This icon appears when Wireless LAN is enabled.

When wireless LAN connection is enabled, the  icon appears.

When Wi-Fi Direct connection is enabled, the  icon appears.

5. ▲/▼

Press to switch pages when the icons are not displayed on 1 page.

6. [Setting]

Press to customize the default settings of the machine to meet your requirements.

7. [Status]

Press to check the machine's system status, operational status of each function, and Locked Print jobs. You can also display the machine's maintenance information.

8. [Card]

Press to make ID card copies.

9. [Copier]

Press to make copies.

For details about how to use the copy function, see page 217 "Copier Settings".

10. Shortcut icon

You can add shortcuts to favorite items to the [Home] screen. For details about how to register shortcuts, see page 31 "Adding to the [Home] Screen Shortcuts to Favorite Items".

For details about examples of shortcuts that you can register, see page 34 "Example of favorite items".

Note

- You can change the order of favorite item icons. For details, see page 31 "Changing the Order of Icons on the [Home] Screen".

Customizing the [Home] Screen

You can add shortcuts to favorite items in the [Home] screen. You can recall favorite items by pressing the shortcut icons. You can rearrange the order of the function and shortcut icons.

How to Customize the [Home] Screen

You can customize the [Home] screen to make it more accessible.

The icons of each application are displayed on the [Home] screen. You can also add shortcuts to favorite items registered in some applications.

For details about the items on the [Home] screen, see page 28 "How to Use the [Home] Screen".

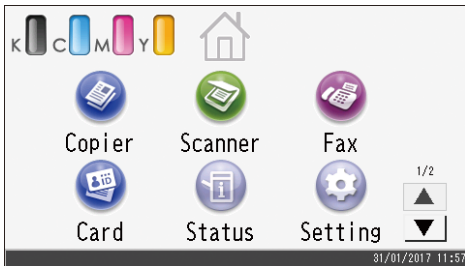

Note

- When you register a favorite item, the shortcut to the favorite item appears on [Home] screens 2 or 3. If [Home] screens 2 and 3 do not have enough space for more icons, registering any more favorite items becomes impossible.
- You can register a total of 12 icons for shortcuts to favorite items, 6 icons on each of the 2 pages.

Adding to the [Home] Screen Shortcuts to Favorite Items

When you register frequently used settings for functions such as copier and fax functions as favorite items, the shortcuts to them appear on [Home] screens 2 or 3. For details about how to register a favorite item, see page 33 "Registering Functions in a Favorite Item".

Changing the Order of Icons on the [Home] Screen

You can change the order of the favorite item icons on [Home] screen 2 and 3 to make them more accessible.

1. Press and hold an icon that you want to move.

2. Select [Move Up] or [Move Down].

The position of an icon switches from that of another icon located ahead or behind.

↓ Note

- You cannot change the order of the icons on the [Home] screen 1.

Deleting an Icon on the [Home] Screen

Delete unused favorite item icons. You can only display icons and shortcuts that you use.

When a shortcut to a favorite item on the [Home] screen is deleted, the registered favorite item is also deleted. For details about how to delete a favorite item, see page 35 "Deleting a Favorite Item".

↓ Note

- You cannot delete icons on the [Home] screen 1.

Registering Frequently Used Functions

You can store frequently used job settings in the machine memory and recall them easily.

1

Registering Functions in a Favorite Item

You can register up to 12 favorite items for each function.

The following settings can be registered to favorite items:

- Copier:
Sim to Dup, Dup to Dup, Paper Tray, Reduce/Enlarge, Quantity, Original Settings, Original Type, Other Settings, Sort
- Fax:
Immed. TX, TX Settings
- Scanner:
Original Settings, Scan Setting

This section explains how to register functions to a favorite item by using each application.

1. Edit the settings so all functions you want to register to a favorite item are selected on the [Copier], [Fax], [Scanner], or [ID Card Copy] screen.
2. Press the favorite item icon () in the upper right of the screen.
3. Press the [Input favorite item name:] box.
4. Enter the favorite item name, and then press [OK].
5. Confirm the name you entered is displayed, and then press [OK].
6. Press the [Home] key.

The favorite item is registered to the [Home] screen.

Note

- You can enter up to 8 characters for a favorite item name.
- Favorite items are not deleted by turning the power off or by pressing the [Clear/Stop] key unless the favorite item is deleted or overwritten.
- Favorite items can be registered to the [Home] screen, and can be recalled easily. For details, see page 31 "Adding to the [Home] Screen Shortcuts to Favorite Items".

Example of favorite items

Copier

Favorite item name	Favorite item description	Effect
Eco copy	Specify [Sim to Dup].	You can save paper and toner.
Thumbnail copy	Specify settings to combine and print a multiple pages on one side or both sides of paper in [Other Settings...].	You can copy up to four pages onto one side of a sheet, so that you can save paper.

Fax

Favorite item name	Favorite item description	Effect
Departmental fax transmission	In [TX Settings], specify [Fax Header].	This setting can be used if the receiver specifies forwarding destinations by senders.

↓ Note

- The names of favorite items given above are just examples. You can assign any name to a favorite item according to your objectives.
- Depending on your business details or the type of documents to be scanned, registering a favorite item cannot be recommended.

Recalling a Favorite Item

You can recall the favorite item and operate the machine using the stored settings.

1. Press the [Home] key.

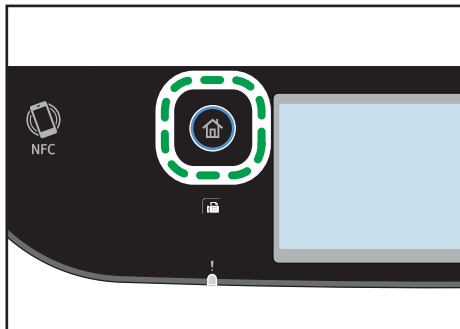

ECC202

2. Press [▼] until the favorite item icon you want appears.
3. Press the favorite item icon.

↓ Note

- Using the favorite item causes the previous settings to be cleared.

Deleting a Favorite Item

1. Press the [Home] key.

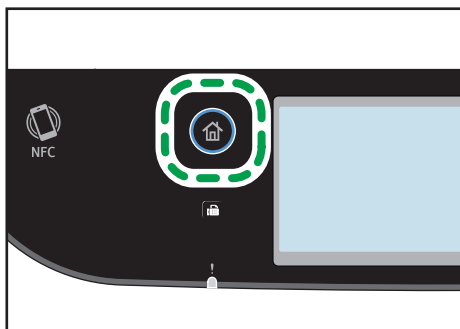

ECC202

2. Press [▼] until the favorite item icon you want appears.
3. Press and hold down the favorite item icon.
4. Press [Delete].

Displaying Frequently Used Modes Preferentially

1

Specify the mode to be displayed immediately after the operation switch is turned on, or when System Reset mode is turned on.

1. Press the [Home] key.

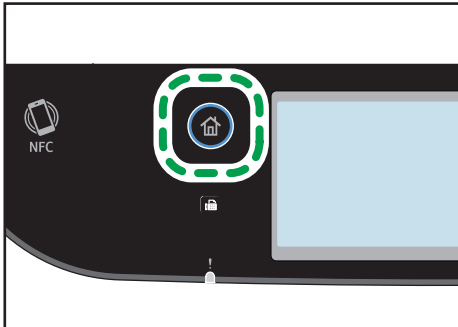

ECC202

2. Press the [Setting] icon.
3. Press [Administrator Tools].
4. Press [▼].
5. Press [Function Priority].
6. Specify the mode to be displayed preferentially.
7. Press the [Home] key.

↓ Note

- For details about which modes you can specify, see "page 251 "Administrator Tools Settings".

Multi-access

This machine can perform multiple jobs using different functions, such as copying and faxing, at the same time. Performing multiple functions simultaneously is called "Multi-access".

The following table shows the functions that can be performed simultaneously.

Current job	Types of jobs that can be executed simultaneously
Copying	<ul style="list-style-type: none"> • Fax memory transmission • Fax memory reception • Internet Fax reception ^{*7} • Receiving a LAN-Fax job from a computer • LAN-Fax transmission
Scanning	<ul style="list-style-type: none"> • Fax memory transmission • Fax memory reception • Printing ^{*1} • Printing a fax received in the machine's memory ^{*6} • Fax immediate printing ^{*6} • Receiving a LAN-Fax job from a computer (except when TWAIN scanning) ^{*6} • LAN-Fax transmission (except when TWAIN scanning) ^{*6} • Internet Fax reception ^{*6} • Mobile printing (from a device) ^{*6}
Scan to USB	<ul style="list-style-type: none"> • Fax memory transmission • Fax memory reception • Printing ^{*1} • Printing a fax received in the machine's memory ^{*6} • Fax immediate printing ^{*6} • Receiving a LAN-Fax job from a computer (except when TWAIN scanning) ^{*6} • LAN-Fax transmission (except when TWAIN scanning) • Internet Fax reception ^{*6} • Mobile printing (from a device) ^{*6}

Current job	Types of jobs that can be executed simultaneously
Fax immediate transmission (scanning an original and sending it simultaneously)	<ul style="list-style-type: none"> • Internet Fax reception • Printing ^{*4} • Mobile printing (from a device)
Fax memory transmission (sending a fax that has already been stored in the machine's memory)	<ul style="list-style-type: none"> • Copying • Scanning • Internet Fax reception • Printing ^{*4} • Mobile printing (from a device)
Fax receiving and printing	<ul style="list-style-type: none"> • Internet Fax reception ^{*7} • Scanning ^{*5}
Fax memory reception (storing a received fax into the machine's memory)	<ul style="list-style-type: none"> • Copying • Scanning • Printing a Fax job in the machine's memory • Internet Fax transmission • Internet Fax reception • Printing ^{*1} • Mobile printing (from a device)
Printing a Fax job in the machine's memory	<ul style="list-style-type: none"> • Fax memory reception • Receiving a LAN-Fax job from a computer • LAN-Fax transmission • Internet Fax reception ^{*7} • Scanning ^{*5}
<ul style="list-style-type: none"> • Receiving a LAN-Fax job from a computer • LAN-Fax transmission 	<ul style="list-style-type: none"> • Copying • Printing a Fax job in the machine's memory • Internet Fax transmission • Internet Fax reception • Scanning ^{*5}

Current job	Types of jobs that can be executed simultaneously
Internet Fax transmission	<ul style="list-style-type: none"> • Fax reception (no printing) • Fax memory reception • Receiving a LAN-Fax job from a computer • LAN-Fax transmission • Internet Fax reception • Printing^{*4} • Mobile printing (from a device)
Internet Fax reception	<ul style="list-style-type: none"> • Fax memory transmission • Fax memory reception • Receiving a LAN-Fax job from a computer • LAN-Fax transmission • Internet Fax transmission • Internet Fax reception^{*7} • Scanning^{*6} • Fax immediate transmission (scanning and sending)^{*6} • Copying^{*8} • Scanning^{*8} • Fax immediate transmission^{*8} • Fax reception^{*8} • Printing a Fax job in the machine's memory^{*8} • Internet Fax reception^{*8} • Printing^{*8} • Mobile printing (from a device)^{*8}
Printing	<ul style="list-style-type: none"> • Scanning^{*2} • Fax immediate transmission^{*3} • Fax memory transmission^{*3} • Fax memory reception • Internet Fax transmission • Internet Fax reception^{*7}

Current job	Types of jobs that can be executed simultaneously
Mobile printing (from a device)	<ul style="list-style-type: none"> • Fax memory transmission • Internet Fax reception ^{*7} • Fax memory reception • Scanning ^{*6} • Fax immediate transmission ^{*6} • Internet Fax transmission ^{*6}

- *1 Printing starts after scanning is finished if [Gradation:] is set to [Standard] or [Fine] (PCL printer driver), or when printing from the PostScript 3 printer driver.
- *2 Scanning is not possible if [Gradation:] is set to [Standard] or [Fine] (PCL printer driver), or when printing from the PostScript 3 printer driver.
- *3 Fax transmission is not possible if [Gradation:] is set to [Fine] (PCL printer driver), or when printing from the PostScript 3 printer driver.
- *4 Printing may be canceled if [Gradation:] is set to [Standard] or [Fine] (PCL printer driver), or when printing from the PostScript 3 printer driver.
- *5 Fax printing may take longer than normal if you scan using the control panel at the same time, especially when scanning multiple pages using the exposure glass.
- *6 Multi-access is possible when each job is performed using the exposure glass or ADF on the M C250FWB. Multi-access is not possible when each job is performed using the exposure glass or ADF on the M C250FW.
- *7 Internet faxes that are received cannot be printed.
- *8 Simultaneous processing is possible only when the current job is to receive an Internet fax but not to print it.

Note

- If you try to use a function that cannot be performed simultaneously, you will hear a beep sound from the machine or see a failure message pop up on your computer screen. In this case, try again after the current job is finished.

About Operation Tools

This section explains the operation tools of this machine.

Control Panel

The control panel contains a screen and keys for controlling the machine. They allow you to configure the machine's various settings.

For details about how to use the control panel, see page 215 "Configuring the Machine Using the Control Panel".

Web Image Monitor

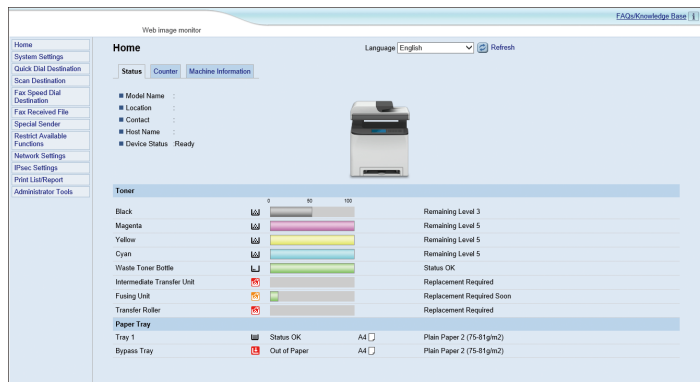

You can check the machine's status and configure its settings by accessing the machine directly using Web Image Monitor.

For details about how to use Web Image Monitor, see page 267 "Configuring the Machine Using Utilities".

Entering Characters

This section describes how to enter text on the screens of the functions such as copier or fax or on the Setting screen.

The cursor appears if you tap the text field. If you tap the text field again after the cursor appears, the keyboard appears.

Character Entry Display

This section explains the entry screen and the keys displayed on it.

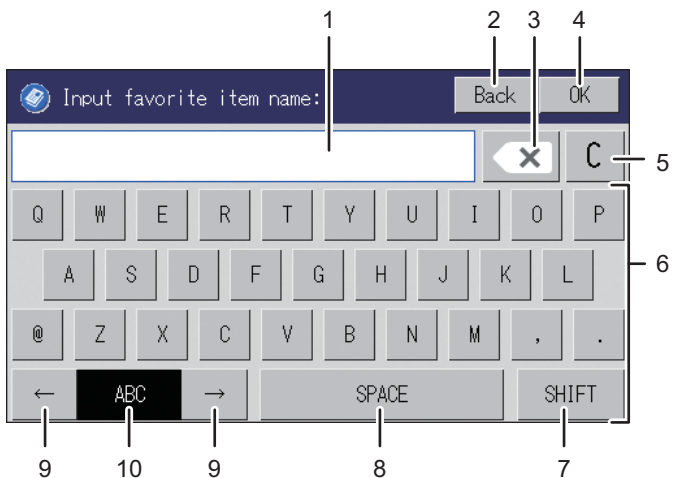

1. Characters you enter are displayed on the text field.
2. Cancels the entered text and closes the character entry display.
3. Deletes the character to the left of the cursor.
4. Confirms text and closes the character entry display.
5. Deletes all characters that have been input.
6. Enters characters.
7. Switches between uppercase and lowercase.
8. Enters a space.
9. You can switch the input method from the menu displayed pressing this key. Press to enter numbers, symbols, and some special characters.
10. Displays the current input method.

Available Characters

You can enter the following characters:

- Alphabetic characters
- Symbols
- Numerals

0123456789

Entering Text

When you enter a character, it appears at the position of the cursor.

Entering letters

1. Press the letters you want to enter.

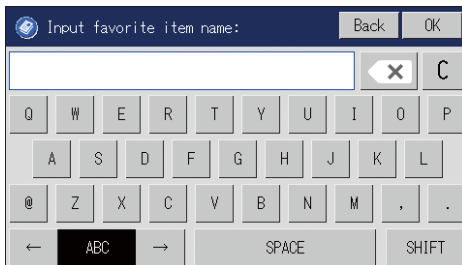

Entering alphanumeric characters and symbols

1. Press [←] or [→].

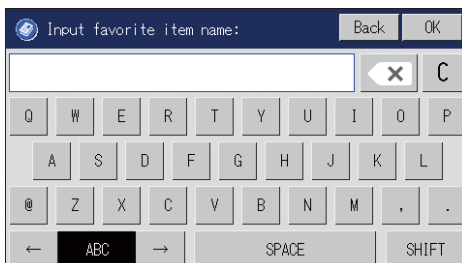

2. Press [123] or [,-.&@%].
3. Press the numbers or symbols you want to enter.

Deleting characters

1. Press [] to delete characters.

1

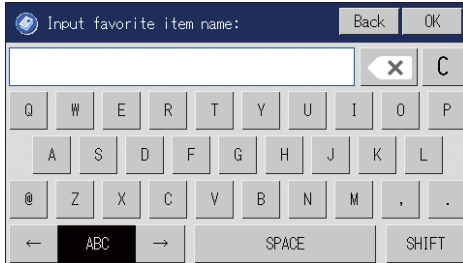

Using RICOH Smart Device Connector

To use RICOH Smart Device Connector, access the App Store or Google Play with your smart device, search for and download the "RICOH Smart Device Connector" application from the site.

Check the App Store or Google Play to see the functions you can use on RICOH Smart Device Connector.

1. Press the [Home] key.

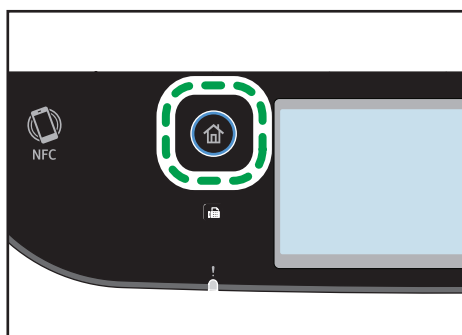

2. Press the [Status] icon on the [Home] screen.

3. Press the [Machine info] tab.

The QR code is displayed on the screen.

4. Start the application on the smart device, and then read the QR code.

Follow the instructions displayed on the application.

For details about how to connect a smart device to the machine using Near-field communication (NFC), see page 46 "Connecting a Smart Device to the Machine Using NFC".

Connecting a Smart Device to the Machine Using NFC

1

This section describes how to connect your smart device to the machine using NFC.

Writing the Machine's Information to the NFC with a Smart Device

1. Configure the network connection of the machine.
2. Access the App Store or Google Play from your smart device, search for and download the application corresponding to the machine from the site.
3. Press the [Home] key.

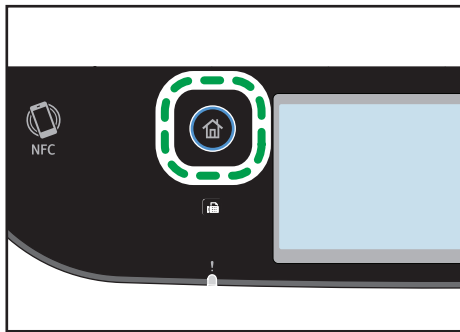

ECC202

4. Press the [Status] icon on the [Home] screen.
5. Press the [Machine info] tab.
The QR code is displayed on the screen.
6. Start the application on the smart device, and then read the QR code.
7. Write the machine's network information to the NFC using the application, and then touch the NFC with the smart device.

Using the Application on a Smart Device by Using NFC

1. Start the application on the smart device, and then touch the NFC with the smart device.
2. Print using application corresponding to the machine by touching the NFC or execute a scan using the application.

2. Paper Specifications and Adding Paper

This chapter describes how to load paper and originals and about their specifications.

Workflow for Loading Paper and Configuring Paper Sizes and Types

This section explains how to load paper and operations required after paper is loaded.

After following the procedures below, you can copy or print on the paper that is loaded in the machine.

1 ▶ **2** ▶ **3** Load paper into the paper tray.



1 ▶ **2** ▶ **3** Specify the paper type and size.



1 ▶ **2** ▶ **3** Specify the paper type and size on the printer driver.

For details about the procedures, refer to the next page.

Procedure	Reference
1	See page 48 "Loading Paper".
2	There are two ways to specify the paper type and size. <ul style="list-style-type: none">• When using the control panel See page 56 "Specifying Paper Type and Paper Size Using the Control Panel".• When using Web Image Monitor See page 59 "Specifying Paper Type and Paper Size Using Web Image Monitor".
3	See page 60 "Specifying Paper Type and Paper Size Using the Printer Driver".

For details about supported paper, see page 62 "Supported Paper".

Loading Paper

This section explains how to load paper into the paper tray and the bypass tray.

CAUTION

- When loading paper, take care not to trap or injure your fingers.

For information about supported paper, precautions for storing paper and print areas, see page 62 "Supported Paper".

Loading Paper into Tray1 and 2

The following example explains the loading procedure for the standard paper tray (Tray 1).

The same procedure applies to loading paper in Tray 2.

Important

- Curled paper may jam. Straighten curled paper before loading.
- After loading paper in the tray, specify the paper type and size using the control panel to avoid printing problems. This machine does not detect the paper size automatically.
- Be sure to select the correct paper size and feed direction using the paper size dial on the tray. Otherwise, the printer might be damaged, or printing problems might occur.
- Make sure the paper stack does not exceed the upper limit mark inside the paper tray. Excessive stacking can cause paper jams.
- If paper jams occur frequently, flip the paper stack in the tray.
- Do not mix different types of paper in the same paper tray.
- After loading paper, specify the paper size using the control panel and paper type using the control panel. When printing a document, specify the same paper size and type in the printer driver as specified on the printer.
- Do not move the side fences and end fence forcefully. Doing so may damage the tray.
- Do not slide the paper tray in forcefully when inserting the loaded tray into the printer. Otherwise, the side and end fences or the paper guide of the bypass tray might move.
- When loading label paper, load it one by one.

1. Pull out the paper tray carefully with both hands.

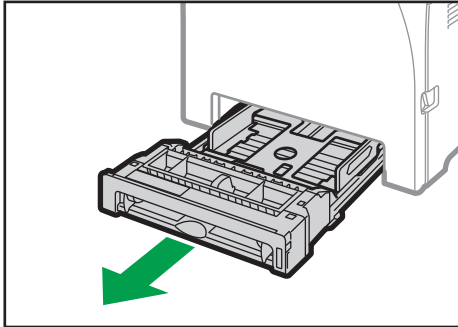

ECC076

Place the tray on a flat surface.

2. Push the metal plate down until it clicks.

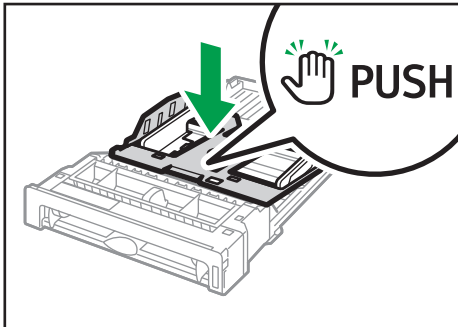

ECC077

3. Align the side fences and end fence with the paper size.

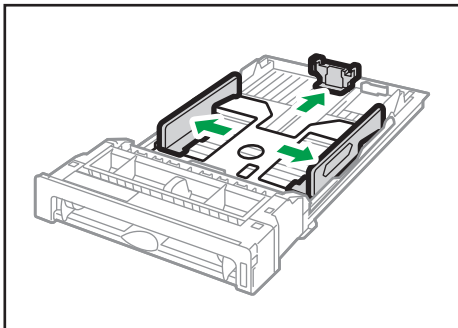

ECC078

4. Fan the paper before loading it.



DAC344

5. Load the paper in the tray with the print side faced up.

Make sure the paper is not stacked higher than the upper limit marked inside the tray.

Make sure the paper is not stacked higher than the projection on the side fences. (Tray 1 only)

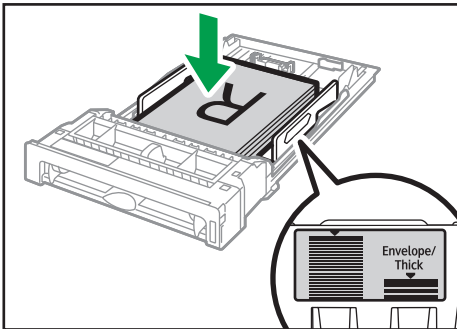

ECC108

6. Check there are no gaps between the paper and the fences; both side and end fences.

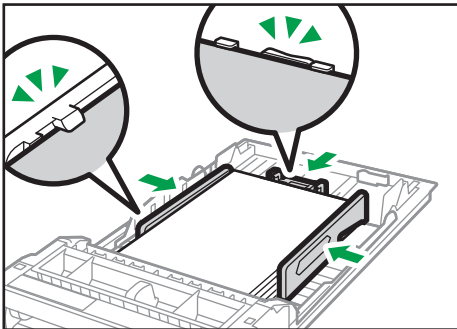

ECC080

7. Carefully push the paper tray straight into the machine.

To avoid paper jams, make sure the tray is securely inserted.

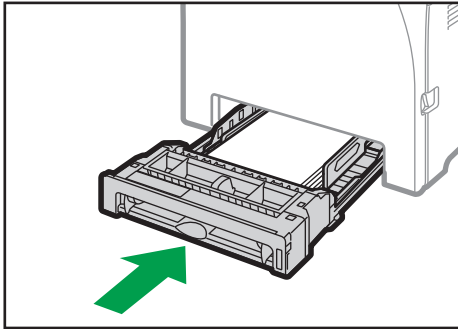

ECC081

Note

- The upper limit differs depending on the paper type (thin or thick paper). See the label inside the tray to check the upper limit.
- The remaining paper indicator on the right front side of the paper tray shows approximately how much paper is remaining.

Extending Tray 1 to load paper

This section explains how to load paper longer than A4 (297 mm) into the machine.

1. Remove the rear cover using a coin.

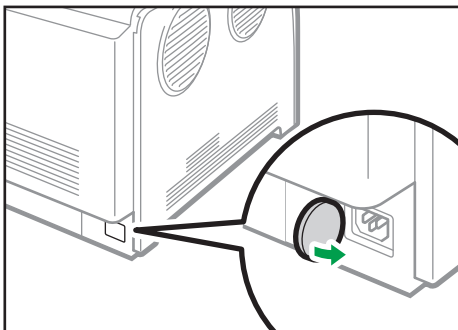

ECC109

2. Pull out tray 1 carefully with both hands.

Place the tray on a flat surface.

3. Push the metal plate down until it clicks.

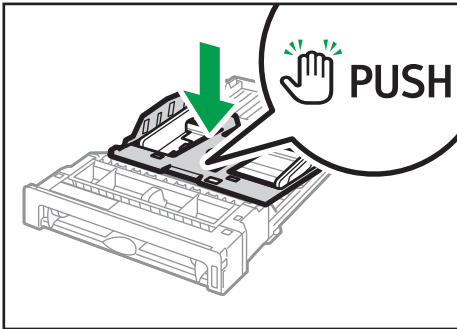

ECC077

4. Pinch the extender, and then pull out the extender until it clicks.

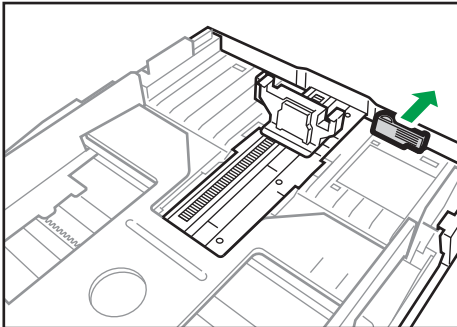

ECC110

After extension, check that the arrows on the extender and tray are aligned.

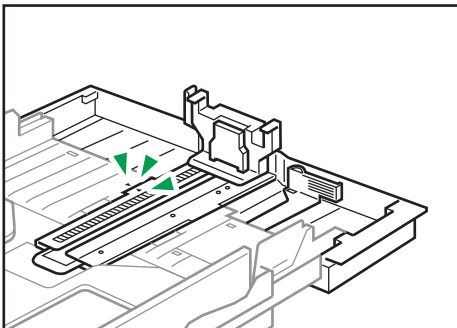

ECC111

5. Follow Steps 3 to 7 in "Loading Paper into Tray1 and 2".

Note

- To reinsert the extender, you might have to push it with moderate force.

Loading Paper into Bypass Tray

★ Important

- Do not load paper while the machine is printing.
- Load paper with the print side down and in the short-edge feed direction.
- Curled paper may jam. Straighten curled paper before loading.
- Duplex printing is not possible.
- Tray 1 and 2 are unavailable if paper is loaded in the bypass tray.
- You cannot load paper into the bypass tray while the machine is in Energy Saver mode.

1. Insert the top edge of the paper into the machine.

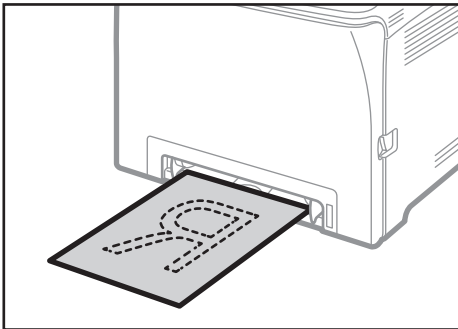

ECC112

2. Adjust the paper guides to the paper size.

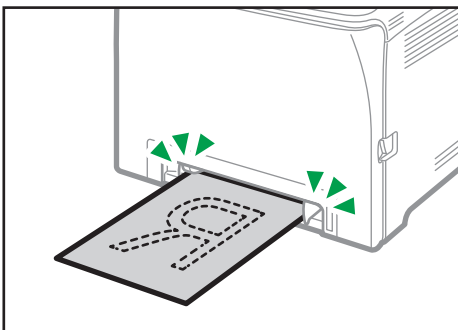

ECC113

3. Support the paper with both hands, and insert it carefully until it stops.

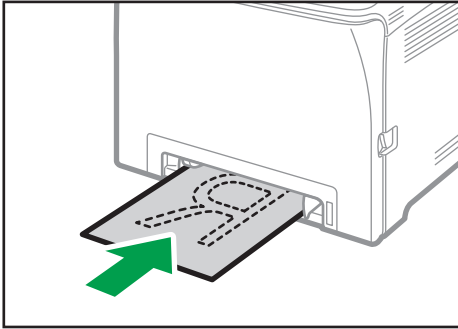

ECC114

Loading Envelopes

★ Important

- Avoid using self-adhesive envelopes. They may cause machine malfunctions.
- Check there is no air in the envelopes before loading.
- Load only one size and type of envelope at a time.
- Before loading envelopes, flatten their leading edges (the edge going into the machine) by running a pencil or ruler across them.
- Some kinds of envelope might cause misfeeds, wrinkles or print poorly.
- Print quality on envelopes may be uneven if parts of an envelope have different thicknesses. Print one or two envelopes to check print quality.
- In a hot and humid environment, the envelope might be output creased or improper printing quality.

For details about loading an envelope, see page 48 "Loading Paper into Tray 1 and 2", and page 53 "Loading Paper into Bypass Tray". Note that you cannot load an envelope in Tray 2.

↓ Note

- If printed envelopes come out badly creased, load the envelopes in the opposite direction, and then rotate the print object by 180 degrees using the printer driver before printing. For details, see the printer driver Help.
- When Using Tray 1
 - If the envelope flap is on a short side, place the envelope with the flap side in the tray recess.
 - If the envelope flap is on a long side, place the envelope with the flap side on the right.

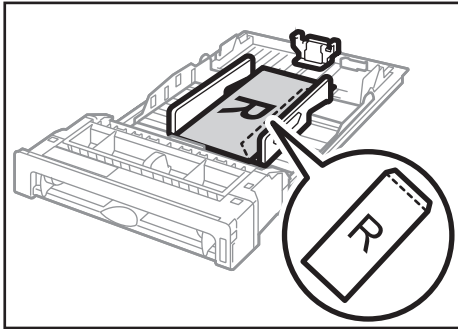

ECC118

- When Using the Bypass Tray

- If the envelope flap is on a short side, place the envelope with the flap side in the front part of the tray. If the envelope flap is on a long side, place the envelope with the flap side on the right.

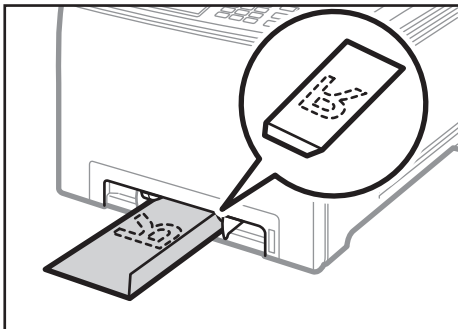

ECC119

Specifying Paper Type and Paper Size Using the Control Panel

This section describes how to specify the paper size and paper type using the control panel.

Note

- Paper type and size can also be specified using the printer driver. For details, see the printer driver Help.
- For prints from the bypass tray or Tray 1, you can select to print according to either the printer driver settings or the control panel settings with [Bypass Tray Priority] or [Tray 1 Priority] under [Paper Settings]. For details about [Bypass Tray Priority] and [Tray 1 Priority], see page 246 "Paper Settings".
- If [Auto Continue] under [System Settings] is enabled, printing stops temporarily if a paper type/size error is detected. The printing restarts automatically with the settings made with the control panel after about ten seconds. For details about [Auto Continue], see page 234 "System Settings".

Specifying the Paper Type

This section describes how to specify the paper type.

1. Press the [Home] key.

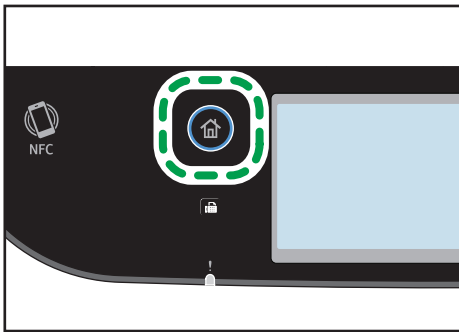

2. Press the [Setting] icon on the [Home] screen.
3. Press [Paper Settings].
4. Select the tray for which you want to specify the paper type.
5. Select the desired paper type.
6. Press the [Home] key.

Specifying the Standard Paper Size

This section describes how to specify the standard paper size.

1. Press the [Home] key.

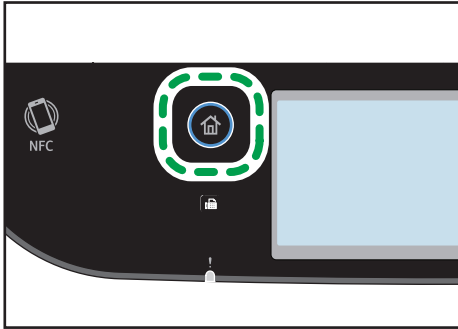

2. Press the [Setting] icon on the [Home] screen.
3. Press [Paper Settings].
4. Select the tray for which you want to specify the paper size.
5. Select the desired paper size.
6. Press the [Home] key.

Specifying a Custom Paper Size

This section describes how to specify a custom paper size.

★ Important

- Custom size paper cannot be loaded in tray 2.
- When you perform printing, make sure that the paper size specified with the printer driver matches the paper size specified with the control panel. If a paper size mismatch occurs, a message appears on the display. To ignore the error and print using mismatched paper, see page 88 "If a Paper Mismatch Occurs".

1. Press the [Home] key.

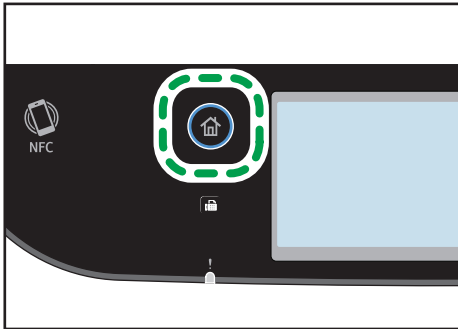

ECC202

2. Press the [Setting] icon on the [Home] screen.
3. Press [Paper Settings].
4. Select the tray for which you want to specify the paper size.
5. Press [▼] twice.
6. Press [Custom Size].
7. Select [mm] or [inch].
8. Press the box next to [Horiz:].
9. Enter the horizontal size, and then press [OK].
You can display the software keyboard by double tapping the entry area on the display.
10. Press the box next to [Vert:].
11. Enter the vertical size, and then press [OK].
12. Confirm the size you entered is displayed, and then press [OK].
13. Press the [Home] key.

Specifying Paper Type and Paper Size Using Web Image Monitor

This section describes how to specify paper sizes and types using Web Image Monitor.

1. Start the web browser and access the machine by entering its IP address.

The top page of Web Image Monitor appears.

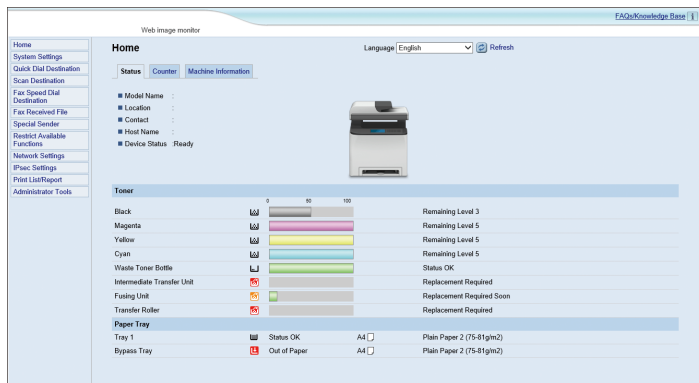

2. Click [System Settings].
3. Click [Tray Paper Settings] tab.
4. Select the paper type and paper size for the tray you want to use.
5. Enter the administrator password if required.
6. Click [OK].
7. Close the web browser.

Specifying a Custom Paper Size

1. Start the web browser and access the machine by entering the IP address.
2. Click [System Settings].
3. Click [Tray Paper Settings] tab.
4. Select [Custom Size] in the [Paper Size] list.
5. Select [mm] or [inch] and specify the width and length.
6. Enter the administrator password if required.
7. Click [OK].
8. Close the web browser.

Specifying Paper Type and Paper Size Using the Printer Driver

★ Important

- Make sure that the paper type and size specified with the printer driver matches the type and size of the paper loaded in the tray. Since this machine does not detect paper sizes automatically, the type or size of the paper may be mismatched and the print job may not print correctly.

When Using Windows

The procedure in this section is an example based on Windows 10. The actual procedure may vary depending on the operating system you are using.

1. Open the [Printing preferences] dialog box from the printer driver.

For information of how to open the printer driver properties from [Devices and Printers], see page 85 "Displaying the Printing Preferences Dialog Box".

The [Printing Preferences] dialog box appears.

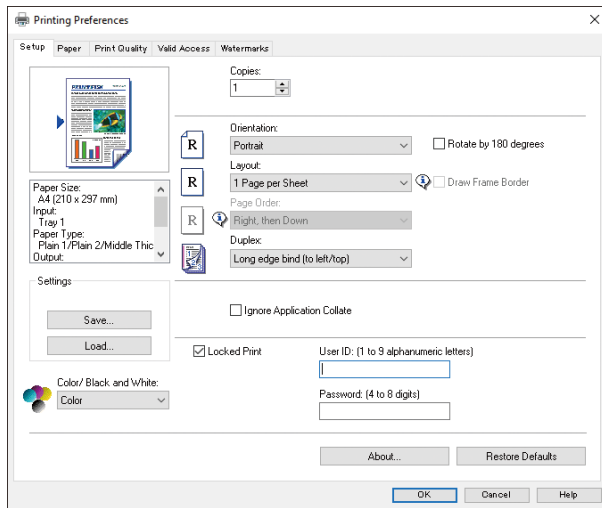

2. Click the [Paper] tab.

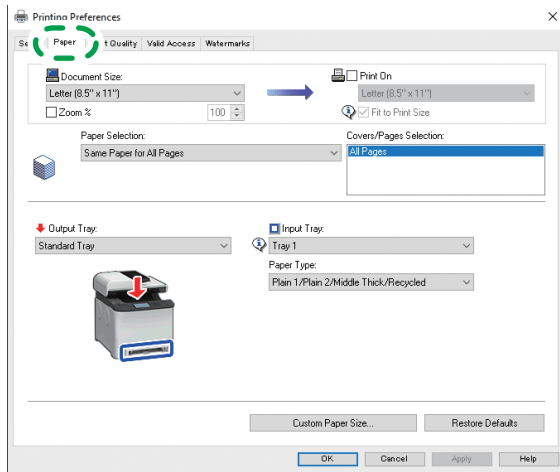

ECC251

3. In the [Input Tray:] list, select the paper tray you want to use for printing.
4. In the [Paper Type:] list, select the type of paper that is loaded in the paper tray.
5. Select the [Print On] check box and select the size of the paper that is loaded in the paper tray.
Clear the [Fit to Print Size] check box as necessary.
6. Click [OK].

When Using OS X/macOS

The procedure in this section is an example based on macOS 10.13. The actual procedure may vary depending on the operating system you are using.

1. Open the document to print.
2. Select [Print...] on the [File] menu.
3. In the [Printer] list, select the printer you are using.
4. In the [Paper Size] list, select the size of the document to be printed.

Supported Paper

★ Important

- After loading paper in the tray, specify the paper type and size using the control panel. This machine does not detect the paper size automatically.
- When loading custom size paper into Tray 1 or the bypass tray, specify the width and length using the control panel and the printer driver.
- When printing on custom size paper from the bypass tray, you can print without specifying the paper type or paper size from the control panel depending on the settings for [Bypass Tray Priority].

Tray 1

Type	Size	Weight	Capacity* 1
Plain Paper 1	A4, B5 JIS, A5 LEF, A5 SEF, B6	60 to 163 g/m ²	250
Plain Paper 2	JIS, A6, 8 ¹ / ₂ × 14, 8 ¹ / ₂ × 11,	(16 to 43 lb.)	(80 g/m ² , 20 lb.)
Middle Thick Paper	5 ¹ / ₂ × 8 ¹ / ₂ , 7 ¹ / ₄ × 10 ¹ / ₂ , 8		
Recycled Paper	× 13, 8 ¹ / ₂ × 13, 8 ¹ / ₄ × 13,		
Thick Paper 1	16K, 4 ¹ / ₈ × 9 ¹ / ₂ , 3 ⁷ / ₈ ×		
Thick Paper 2	7 ¹ / ₂ , C5 Env, C6 Env, DL Env,		
Thin Paper	8 ¹ / ₂ × 13 ² / ₅ , 8 ¹ / ₂ × 13 ³ / ₅		
Letterhead			
Preprinted Paper			
Label Paper			
Prepunched Paper			
Bond Paper			
Cardstock			
Color Paper			
Envelope			

Type	Size	Weight	Capacity* ¹
Plain Paper 1	Custom size:	60 to 163 g/m ²	250
Plain Paper 2	90 to 216 mm in width,	(16 to 43 lb.)	(80 g/m ² , 20 lb.)
Middle Thick Paper	148 to 356 mm in length		
Recycled Paper	(3.54 to 8.50 inches in width,		
Thick Paper 1	5.83 to 14.0 inches in length)		
Thick Paper 2			
Thin Paper			
Letterhead			
Preprinted Paper			
Label Paper			
Prepunched Paper			
Bond Paper			
Cardstock			
Color Paper			
Envelope			

* 1 The number of envelopes that can be loaded is up to 10.

Tray 2 (option)

Type	Size	Weight	Capacity
Thin Paper	A4	60 to 105 g/m ²	500
Plain Paper 1	Letter (8 ¹ / ₂ × 11 inches)	(16 to 28 lb.)	(80 g/m ² , 20 lb.)
Plain Paper 2			
Middle Thick Paper			
Thick Paper 1			
Recycled Paper			
Color Paper			
Preprinted Paper			
Prepunched Paper			
Letterhead			

Bypass tray

Type	Size	Weight	Capacity
Plain Paper 1 Plain Paper 2 Middle Thick Paper Recycled Paper Thick Paper 1 Thick Paper 2 Thin Paper Letterhead Envelope Label Paper Prepunched Paper Bond Paper Cardstock Color Paper	A4, B5 JIS, A5 LEF, A5 SEF, B6 JIS, A6, 8 ¹ / ₂ × 14, 8 ¹ / ₂ × 11, 5 ¹ / ₂ × 8 ¹ / ₂ , 7 ¹ / ₄ × 10 ¹ / ₂ , 8 × 13, 8 ¹ / ₂ × 13, 8 ¹ / ₄ × 13, 16K, 4 ¹ / ₈ × 9 ¹ / ₂ , 3 ⁷ / ₈ × 7 ¹ / ₂ , C5 Env, C6 Env, DL Env, 8 ¹ / ₂ × 13 ² / ₅ , 8 ¹ / ₂ × 13 ³ / ₅	60 to 163 g/m ² (16 to 43 lb.)	1
Plain Paper 1 Plain Paper 2 Middle Thick Paper Recycled Paper Thick Paper 1 Thick Paper 2 Thin Paper Letterhead Envelope Label Paper Prepunched Paper Bond Paper Cardstock Color Paper	Custom size: 90 to 216 mm in width, 148 to 356 mm in length (3.54 to 8.50 inches in width, 5.83 to 14.0 inches in length)	60 to 163 g/m ² (16 to 43 lb.)	1

Note

- You cannot print on Legal size paper in the following cases:

- PCL printer driver
When [Gradation:] in [Print Quality] is set to [Fine]
- PostScript 3 printer driver
When [Print Quality] in [Printer Features] is set to [Best Quality]

Specifications of Paper Types

2

The following tables describe the types of paper that can be used with this machine.

★ Important

- Depending on the paper type, the toner may take a while to dry. Before handling printed sheets, make sure that they have fully dried. Otherwise, the toner may smudge.
- Print quality can be guaranteed only if recommended paper is used. For more information about the recommended paper, contact your sales or service representative.

Plain Paper 1

Item	Description
Paper thickness	66 to 74 g/m ² (18 to 20 lb.)
Supported paper tray	Can be used with any of the paper trays.
Duplex supported size	A4, B5 JIS, 8 ¹ / ₂ × 14, 8 ¹ / ₂ × 11, 7 ¹ / ₄ × 10 ¹ / ₂ , 8 × 13, 8 ¹ / ₂ × 13, 8 ¹ / ₄ × 13, 16K, 8 ¹ / ₂ × 13 ² / ₅ , 8 ¹ / ₂ × 13 ³ / ₅

Plain Paper 2

Item	Description
Paper thickness	75 to 81 g/m ² (20 to 22 lb.)
Supported paper tray	Can be used with any of the paper trays.
Duplex supported size	A4, B5 JIS, 8 ¹ / ₂ × 14, 8 ¹ / ₂ × 11, 7 ¹ / ₄ × 10 ¹ / ₂ , 8 × 13, 8 ¹ / ₂ × 13, 8 ¹ / ₄ × 13, 16K, 8 ¹ / ₂ × 13 ² / ₅ , 8 ¹ / ₂ × 13 ³ / ₅

Middle Thick Paper

Item	Description
Paper thickness	82 to 90 g/m ² (22 to 24 lb.)
Supported paper tray	Can be used with any of the paper trays.
Duplex supported size	A4, B5 JIS, 8 ¹ / ₂ × 14, 8 ¹ / ₂ × 11, 7 ¹ / ₄ × 10 ¹ / ₂ , 8 × 13, 8 ¹ / ₂ × 13, 8 ¹ / ₄ × 13, 16K, 8 ¹ / ₂ × 13 ² / ₅ , 8 ¹ / ₂ × 13 ³ / ₅

Thick Paper 1

Item	Description
Paper thickness	91 to 105 g/m ² (24 to 28 lb.)
Supported paper tray	Can be used with any of the paper trays.
Duplex supported size	None
Notes	The number of sheets that can be printed per minute is approximately half that of middle thick paper.

Thick Paper 2

Item	Description
Paper thickness	106 to 163 g/m ² (28 to 43 lb.)
Supported paper tray	Tray 1 and bypass tray
Duplex supported size	None
Notes	The number of sheets that can be printed per minute is approximately half that of middle thick paper.

Thin Paper

Item	Description
Paper thickness	60 to 65 g/m ² (16 to 17 lb.)

Item	Description
Supported paper tray	Can be used with any of the paper trays.
Duplex supported size	A4, B5 JIS, $8\frac{1}{2} \times 14$, $8\frac{1}{2} \times 11$, $7\frac{1}{4} \times 10\frac{1}{2}$, 8×13 , $8\frac{1}{2} \times 13$, $8\frac{1}{4} \times 13$, 16K, $8\frac{1}{2} \times 13\frac{2}{5}$, $8\frac{1}{2} \times 13\frac{3}{5}$

Recycled Paper

Item	Description
Paper thickness	75 to 90 g/m ² (20 to 24 lb.)
Supported paper tray	Can be used with any of the paper trays.
Duplex supported size	A4, B5 JIS, $8\frac{1}{2} \times 14$, $8\frac{1}{2} \times 11$, $7\frac{1}{4} \times 10\frac{1}{2}$, 8×13 , $8\frac{1}{2} \times 13$, $8\frac{1}{4} \times 13$, 16K, $8\frac{1}{2} \times 13\frac{2}{5}$, $8\frac{1}{2} \times 13\frac{3}{5}$
Notes	If the paper thickness is outside the specified range, select [Thin Paper], [Plain Paper], [Thick Paper 1], or [Thick Paper 2].

Color Paper

Item	Description
Paper thickness	75 to 90 g/m ² (20 to 24 lb.)
Supported paper tray	Can be used with any of the paper trays.
Duplex supported size	A4, B5 JIS, $8\frac{1}{2} \times 14$, $8\frac{1}{2} \times 11$, $7\frac{1}{4} \times 10\frac{1}{2}$, 8×13 , $8\frac{1}{2} \times 13$, $8\frac{1}{4} \times 13$, 16K, $8\frac{1}{2} \times 13\frac{2}{5}$, $8\frac{1}{2} \times 13\frac{3}{5}$
Notes	If the paper thickness is outside the specified range, select [Thin Paper], [Plain Paper], [Thick Paper 1], or [Thick Paper 2].

Preprinted Paper

Item	Description
Paper thickness	75 to 90 g/m ² (20 to 24 lb.)
Supported paper tray	Tray 1 and Tray 2

Item	Description
Duplex supported size	A4, B5 JIS, $8\frac{1}{2} \times 14$, $8\frac{1}{2} \times 11$, $7\frac{1}{4} \times 10\frac{1}{2}$, 8×13 , $8\frac{1}{2} \times 13$, $8\frac{1}{4} \times 13$, 16K, $8\frac{1}{2} \times 13\frac{2}{5}$, $8\frac{1}{2} \times 13\frac{3}{5}$
Notes	If the paper thickness is outside the specified range, select [Thin Paper], [Plain Paper], [Thick Paper 1], or [Thick Paper 2].

Prepunched Paper

Item	Description
Paper thickness	75 to 90 g/m ² (20 to 24 lb.)
Supported paper tray	Can be used with any of the paper trays.
Duplex supported size	A4, B5 JIS, $8\frac{1}{2} \times 14$, $8\frac{1}{2} \times 11$, $7\frac{1}{4} \times 10\frac{1}{2}$, 8×13 , $8\frac{1}{2} \times 13$, $8\frac{1}{4} \times 13$, 16K, $8\frac{1}{2} \times 13\frac{2}{5}$, $8\frac{1}{2} \times 13\frac{3}{5}$
Notes	If the paper thickness is outside the specified range, select [Thin Paper], [Plain Paper], [Thick Paper 1], or [Thick Paper 2].

Letterhead

Item	Description
Paper thickness	75 to 90 g/m ² (20 to 24 lb.)
Supported paper tray	Can be used with any of the paper trays.
Duplex supported size	A4, B5 JIS, $8\frac{1}{2} \times 14$, $8\frac{1}{2} \times 11$, $7\frac{1}{4} \times 10\frac{1}{2}$, 8×13 , $8\frac{1}{2} \times 13$, $8\frac{1}{4} \times 13$, 16K, $8\frac{1}{2} \times 13\frac{2}{5}$, $8\frac{1}{2} \times 13\frac{3}{5}$
Notes	Paper that has a thickness outside the specified range cannot be printed onto.

Bond Paper

Item	Description
Paper thickness	106 to 163 g/m ² (28 to 43 lb.)
Supported paper tray	Tray 1 and bypass tray

Item	Description
Duplex supported size	None
Notes	<ul style="list-style-type: none"> The number of sheets that can be printed in one minute is approximately half that of middle thick paper. If the paper thickness is outside the specified range, select [Thick Paper 1].

Cardstock

Item	Description
Paper thickness	106 to 163 g/m ² (28 to 43 lb.)
Supported paper tray	Tray 1 and bypass tray
Duplex supported size	None
Notes	<ul style="list-style-type: none"> The number of sheets that can be printed in one minute is approximately half that of middle thick paper. If the paper thickness is outside the specified range, select [Thick Paper 1].

Label Paper

Item	Description
Supported paper tray	Tray 1 and bypass tray
Duplex supported size	None
Notes	<ul style="list-style-type: none"> The number of sheets that can be printed per minute is approximately half that of middle thick paper. Avoid using adhesive label paper on which glue is exposed. Glue may stick to the inner parts of the machine, which can cause paper feed problems, deterioration in print quality, or premature wear of the print cartridge's photo conductor unit.

Envelope

Item	Description
Supported paper tray	Tray 1 and bypass tray
Duplex supported size	None

2

Notes

- Avoid using self-adhesive envelopes. They may cause machine malfunctions.
- The number of envelopes that can be printed per minute is approximately half that of middle thick paper.
- Paper can be loaded only up to the lower of the two paper limit marks of the tray.
- If printed envelopes come out badly creased, load the envelopes in the opposite direction. Also, configure the printer driver to rotate the print object 180 degrees. For details about changing the orientation see the printer driver Help.
- Environmental factors can degrade the print quality on both recommended and non-recommended envelopes.
- If envelopes are severely curled after printing, flatten them by bending them back against the curl.
- After printing, envelopes sometimes have creases along their long edges and toner smear on their unprinted sides. Print images might also be blurred. When printing large, black-solid areas, striping can occur as a result of the envelopes overlapping.
- To correctly specify the length of an envelope whose flap opens along its short edge, be sure to include the open flap when measuring.

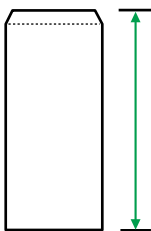

CER112

- Fan envelopes, and then align their edges before loading.

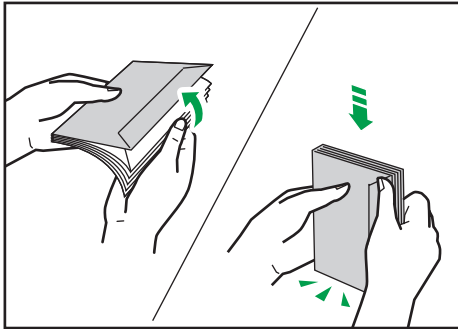

DAC573

- When fanning envelopes, make sure they are not stuck together. If they are stuck together, separate them.
- When fanning envelopes, make sure the envelope flaps are not stuck. If they are stuck, separate them.
- Before loading envelopes, flatten them out so that their curl does not exceed that shown as shown below.

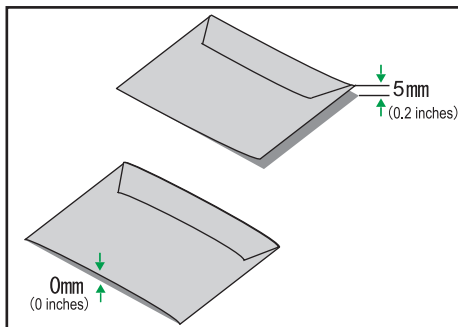

DAC574

- If the curl is severe, flatten out the envelopes using your fingers, as shown below.

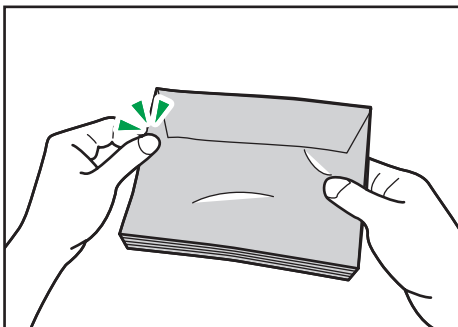

DAC575

↓ Note

- You may not be able to perform duplex printing on 8×13 , $8\frac{1}{2} \times 13$, Folio ($8\frac{1}{4} \times 13$ inches), or 16K (195 mm \times 267 mm) size paper in the following cases:

- PCL printer driver
When [Gradation:] in [Print Quality] is set to Fine
- PostScript 3 printer driver
When [Print Quality] in [Printer Features] is set to [Best Quality]

Non-Recommended Paper Types

Do not use the following types of paper:

- Ink-jet printer paper
- Bent, folded, or creased paper
- Curled or twisted paper
- Torn paper
- Wrinkled paper
- Damp paper
- Dirty or damaged paper
- Paper that is dry enough to emit static electricity
- Paper that has already been printed onto, except a preprinted letterhead paper.
Malfunctions are especially likely when using paper printed on by other than a laser printer (e.g.monochrome and color copiers, ink-jet printers, etc.)
- Special paper, such as thermal paper and carbon paper
- Paper weighing heavier or lighter than the limit
- Paper with windows, holes, perforations, cutouts, or embossing
- Adhesive label paper on which glue or base paper is exposed
- Paper with clips or staples

↓ Note

- When loading paper, take care not to touch the surface of the paper.
- Even if paper is adequate for the machine, poorly stored paper can cause paper misfeeds, print quality degradation, or malfunctions.

Paper Storage

★ Important

- **Store paper appropriately. If the paper is stored incorrectly, misfeeds, lower printing quality, or malfunctions may result.**

When storing paper:

- Do not store paper in a humid place.
- Do not store paper in direct sunlight.
- Do not stand paper on its edge.
- Store any leftover paper in a wrapping or box supplied with the paper.

Print Area

The diagram below shows the area of the paper that the machine can print on.

From the printer driver

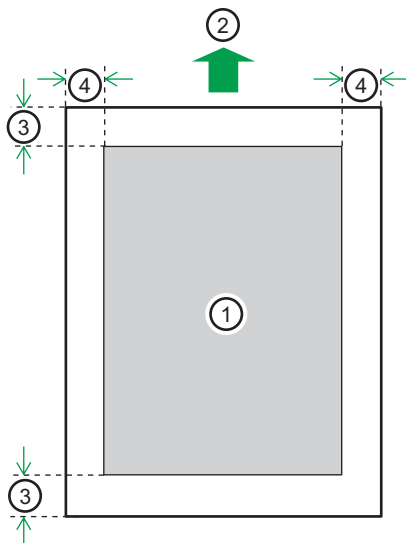

DAC571

1. Print area
2. Feed direction
3. Approx. 4.2 mm (0.2 inches)
4. Approx. 4.2 mm (0.2 inches)

Envelope

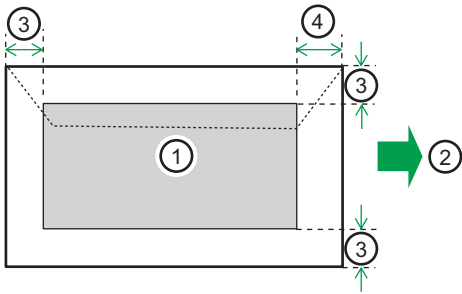

DAC577

- 1. Print area
- 2. Feed direction
- 3. Approximately 10 mm (0.4 inches)
- 4. Approximately 15 mm (0.6 inches)

Copier function

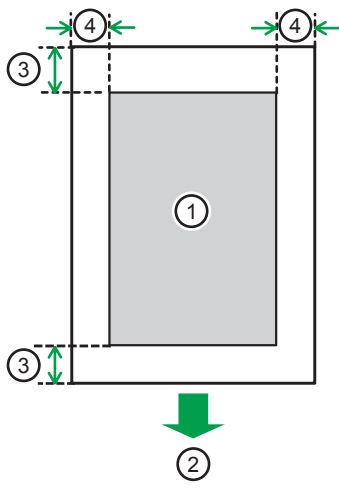

DAC580

- 1. Print area
- 2. Feed direction
- 3. Approx. 4 mm (0.2 inches)
- 4. Approx. 3 mm (0.1 inches)

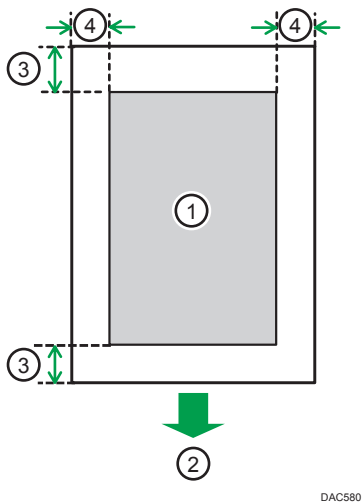
Fax function

1. Print area
2. Feed direction
3. Approx. 4.2 mm (0.2 inches)
4. Approx. 2 mm (0.08 inches)

Note

- Borderless printing is not supported.
- The print area may vary depending on the paper size, printer language and printer driver settings.
- For better envelope printing, we recommend you set the right, left, top, and bottom print margins to at least 15 mm (0.6 inches) each.

Placing Originals

This section describes the types of originals you can set and how to place them.

Placing Originals on the Exposure Glass

2

This section describes the procedure for placing originals on the exposure glass.

★ Important

- Do not place originals before any correction fluid and toner has completely dried. Doing so may make marks on the exposure glass that will appear on copies.
- The original in the ADF takes precedence over the original on the exposure glass if you place originals both in the ADF and on the exposure glass.
- Be careful not to hold the input tray when lifting the ADF, for the tray might be damaged.

1. Lift the ADF.
2. Place the original face down on the exposure glass. The original should be aligned to the rear left corner.

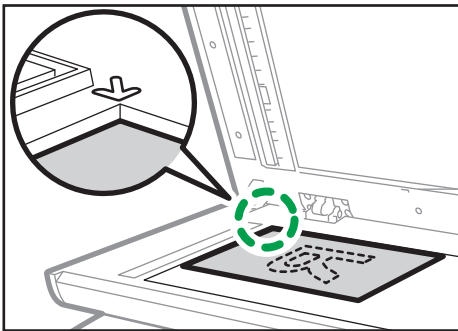

ECC120

3. Lower the ADF.

Hold down the ADF with your hands when using thick, folded, or bound originals and when the ADF cannot be lowered completely.

Placing Originals in the Auto Document Feeder

By using the ADF, you can scan multiple pages at once.

★ Important

- Do not place different size originals in the ADF at once.
- Straighten curls in the originals before placing them in the ADF.

- To prevent multiple sheets from being fed at once, fan the pages of your original before placing them in the ADF.
 - Place the original squarely.
1. Open the cover of the input tray for the ADF and adjust the guides according to the size of the original.

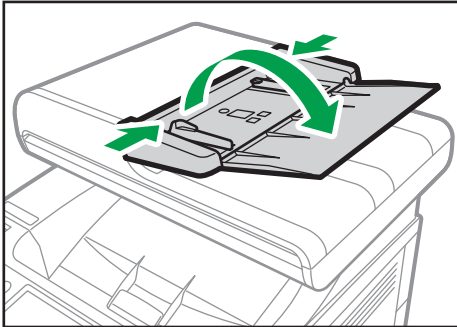

ECC121

2. Place the aligned originals face up in the ADF. The last page should be on the bottom.

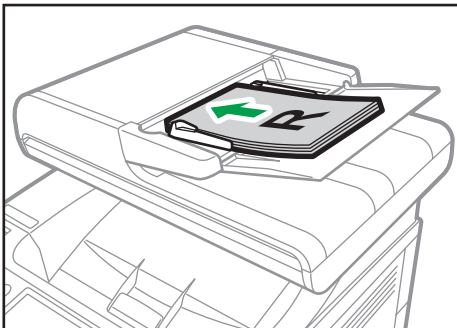

ECC122

↓ Note

- When placing originals longer than A4 or $8\frac{1}{2} \times 11$, pull out the ADF tray's extenders.

About Originals

This section describes the types of originals that can be placed and the parts of the original that are unscannable.

Recommended size of originals

This section describes the recommended size of the original.

Exposure glass

Up to 216 mm (8.5 inches) in width, up to 297 mm (11.7 inches) in length

ADF

- Paper size: 140 to 216 mm (5¹/₂ to 8¹/₂ inches) in width, 140 to 356 mm (5¹/₂ to 14 inches) in length
- Paper weight: 52 to 105 g/m² (13.8 to 28.0 lb.)

Note

- Only 1 sheet of an original can be placed on the exposure glass at a time.
- In the ADF, up to 50 sheets of originals can be placed at once (when using paper weighing 80 g/m², 20 lb.).

Types of originals not supported by the Auto Document Feeder

If placed in the ADF, the following types of original might be damaged or become jammed, or result in gray or black lines appearing on prints:

- Originals larger or heavier than recommended
- Stapled or clipped originals
- Perforated or torn originals
- Curled, folded, or creased originals
- Pasted originals
- Originals with any kind of coating, such as thermal fax paper, art paper, aluminum foil, carbon paper, or conductive paper
- Originals with perforated lines
- Originals with indexes, tags, or other projecting parts
- Sticky originals such as translucent paper
- Thin, highly flexible originals
- Thick originals such as postcards
- Bound originals such as books
- Transparent originals such as OHP transparencies or translucent paper
- Originals that are wet with toner or white out

Unscannable image area

Even if you correctly place originals in the ADF or on the exposure glass, margins of a few millimeters on all four sides of the original might not be scanned.

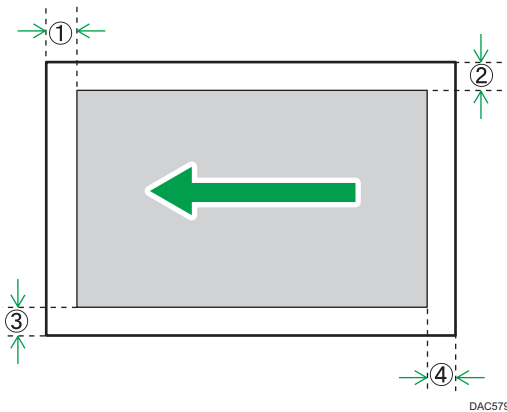

Margins when using exposure glass

	In copier mode	In scanner mode	In fax mode
① Top	4 mm (0.2 inches)	0 mm (0 inches)	1 mm (0.05 inches)
② Right	3 mm (0.1 inches)	0 mm (0 inches)	1 mm (0.05 inches)
③ Left	3 mm (0.1 inches)	0 mm (0 inches)	1 mm (0.05 inches)
④ Bottom	4 mm (0.2 inches)	0 mm (0 inches)	2 mm (0.08 inches)

Margins when using ADF

	In copier mode	In scanner mode	In fax mode
① Top	4 mm (0.2 inches)	0 mm (0 inches)	0 mm (0 inches)
② Right	3 mm (0.1 inches)	0 mm (0 inches)	1 mm (0.05 inches) (Letter, Legal) 0 mm (0 inches) (other sizes)
③ Left	3 mm (0.1 inches)	0 mm (0 inches)	1 mm (0.05 inches) (Letter, Legal) 0 mm (0 inches) (other sizes)
④ Bottom	4 mm (0.2 inches)	2 mm (0.08 inches)	2 mm (0.08 inches)

3. Printing Documents

This chapter describes how to configure settings on the printer driver and print documents.

What You Can Do with the Printer Function

Duplex printing

You can print on both sides of a sheet of paper. For details, see the printer driver Help.



DSG261

Combined printing

You can combine multiple pages and print them on a single sheet of paper. For details, see the printer driver Help.



DSG262

Configuring Option Settings for the Printer

When bidirectional communication works correctly, your computer obtains information about option, paper size and paper feed direction settings from the machine automatically. Bidirectional communication also allows you to monitor machine status.

Conditions for Bidirectional Communication

3

To support bidirectional communication, the following conditions must be met:

When connected with the network

- The Standard TCP/IP port must be used.
- In addition to the above, one of the following conditions must also be met:
 - The TCP/IP protocol or the IPP protocol is used. (When using the IPP protocol, the IPP port name must include the IP address.)

When connected with USB

- The machine must be connected to the computer's USB port using the USB interface cable.
- The computer must support bidirectional communication.
- [Enable bidirectional support] must be selected, and [Enable printer pooling] must not be selected on the [Ports] tab with the printer driver.

If Bidirectional Communication is Disabled

This section describes how to set up option and setting of paper size for each tray on your computer manually.

★ Important

- **Manage Printers permission is required to change the printer properties. Log on as an Administrators group member.**

When Using Windows

The procedure in this section is an example based on Windows 10.

1. On the [Start] menu, select [Control Panel] under [Windows System].
2. Click [View devices and printers].
3. Right-click the machine's icon, and then click [Printer properties].

4. Click the [Accessories] tab.

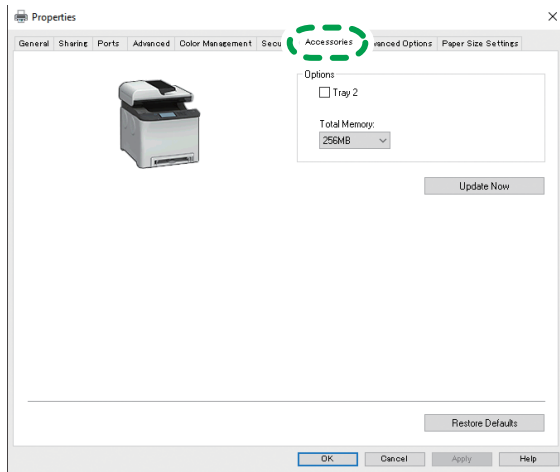

ECC252

5. Select options installed from the [Options] area, and then make the necessary settings.

6. Click [Paper Size Settings] tab.

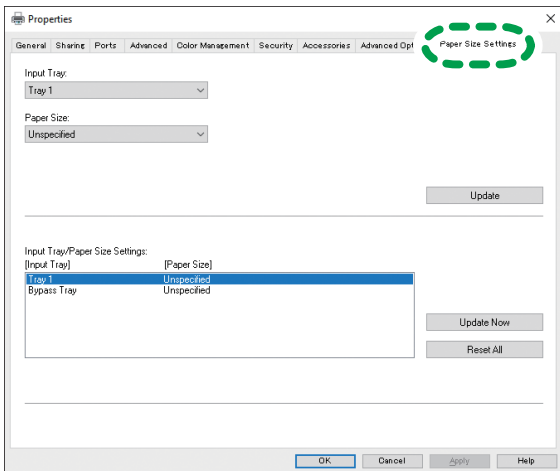

ECC253

7. In [Input Tray:] select which trays to use, and then, in [Paper Size:] select the size of the paper that you want to load in each tray.

Click [Update] to apply the setting for each tray.

8. Click [Apply].

9. Click [OK] to close the printer properties window.

When Using OS X/macOS

The following procedure is explained using macOS 10.13 as an example.

1. Start System Preferences.
2. Click [Printers & Scanners].
3. Select the printer you are using, and then click [Options & Supplies...].
4. Click [Options], and then configure settings as needed.
5. Click [OK].
6. Quit System Preferences.

Displaying the Printing Preferences Dialog Box

To change the default settings of the printer driver, configure settings in the [Printing Preferences] dialog box.

To change the default settings of all applications, open the [Printing Preferences] dialog box from the OS. For details, see page 85 "Displaying the Printing Preferences Dialog Box from the [Start] Menu".

To change the default settings of a specific application, open the [Printing Preferences] dialog box from that application. For details, see page 85 "Displaying the Printing Preferences Dialog Box in an Application".

Displaying the Printing Preferences Dialog Box from the [Start] Menu

This section explains how to open the [Printing Preferences] dialog box from [Devices and Printers].

★ Important

- When the printer driver is distributed from the print server, the setting values specified by the server are displayed as the default for [Printing Defaults...].
- You cannot configure different print settings for each user. The settings configured in this dialog box are used as the default.

1. On the [Start] menu, click [Control Panel] under [Windows System].
2. Click [View devices and printers].
3. Right-click the icon of the printer you want to use.
4. Click [Printing preferences].

Displaying the Printing Preferences Dialog Box in an Application

You can make printer settings for a specific application. To make printer settings for a specific application, open the [Printing Preferences] dialog box from that application.

The settings displayed in the [Printing Preferences] dialog box opened from the [Devices and Printers] window are applied as the default in the [Printing Preferences] dialog box opened in an application. When printing from an application, modify the settings as required.

The screens displayed may differ depending on the application. The following procedure explains how to print documents from an application using WordPad in Windows 10 as an example.

Displaying the Printing Preferences Dialog Box in an Application When Using Windows

1. Click [File] in the upper left corner of the window, and then click [Print].

2. In the [Select Printer] list, select the printer you want to use.
3. Click [Preferences].

Note

- Procedures for opening the [Printing Preferences] dialog box vary depending on the application. For details, see the printer driver Help or the manuals provided with the application.

Displaying the Printing Preferences Dialog Box in an Application When Using OS X/ macOS

3

The following procedure is explained using macOS 10.13 as an example.

1. Open the document to print.
2. Select [Print...] on the [File] menu.
3. Check that the machine name or IP address you are using is selected in the [Printer:] popup menu.

If the machine name or IP address you are using is not selected in the [Printer:] list, click the list, and then select the machine.

Basic Operation of Printing

The following procedure explains how to perform basic printing.

★ Important

- Duplex printing is selected as the default setting.

When Using Windows

The procedure in this section is an example based on Windows 10. The actual procedure may vary depending on the operating system you are using.

For details of printing options, see the printer driver Help.

1. Open the printer properties dialog box in your document's application.

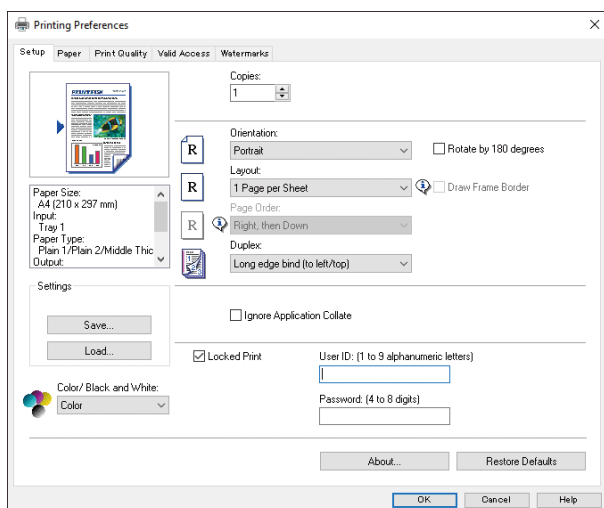

For details about each setting, click [Help]. You can also click the information icons to show configuration information.

2. Set printing options as necessary, and then click [OK].

The printer properties dialog box closes.

3. Click [Print].

When Using macOS/OS X

The procedure in this section is an example based on macOS 10.13. The actual procedure may vary depending on the operating system you are using.

1. Open the printer properties dialog box in your document's application.

For details, see page 86 "Displaying the Printing Preferences Dialog Box in an Application When Using OS X/macOS".

2. Set printing options as necessary, and then click [OK].

The printer properties dialog box closes.

3. Click [Print].

Note

- When printing a job (Color/B&W or B&W only) is restricted, specify the user code in the printer properties of the printer driver before printing. For details about user code, see page 287 "Restricting Machine Functions According to User".
- You can specify which paper tray is selected first in [Paper Tray Priority] under [Paper Settings] when the trays are automatically selected while you are printing. For details about [Paper Tray Priority], see page 246 "Paper Settings".
- If a paper jam occurs, printing stops after the current page has been printed out. After the jammed paper is removed, printing restarts from the jammed page automatically. For details about how to remove the jammed paper, see page 349 "Removing Paper Jams".

If a Paper Mismatch Occurs

The machine reports an error if:

- The paper type does not match the print job's settings when [Input Tray:] is set to [Auto Tray Select].

There are two ways to resolve these errors:

Continue printing using mismatched paper

Ignore the error and print using mismatched paper.

Cancel the print job

Cancel printing.

Note

- If [Auto Continue] under [System Settings] is enabled, the machine ignores the paper type and size settings and prints on whatever paper is loaded. Printing stops temporarily when the error is detected, and restarts automatically after about ten seconds using the settings made on the control panel. For details about [Auto Continue], see page 234 "System Settings".

Continuing printing using mismatched paper

If the paper is too small for the print job, the printed image will be cropped.

1. Press [FormFeed] while the error message is being displayed.

Canceling a Print Job

You can cancel print jobs using either the machine's control panel or your computer, depending on the status of the job.

Canceling a print job before printing has started

- Windows
 1. Double-click the printer icon on the task tray of your computer.
 2. Select the print job you want to cancel, click the [Document] menu, and then click [Cancel].
 3. Click [Yes].
- OS X and macOS
 1. Start System Preferences.
 2. Click [Printers & Scanners].
 3. Select the printer you are using, and then click [Open Print Queue...].
 4. Select the queue you want to delete.
 5. Click [✕].

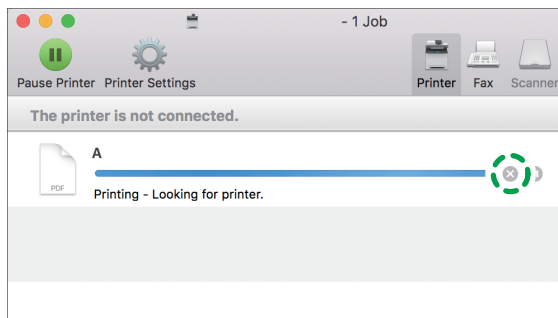

ECC272

↓ Note

- If you cancel a print job that has already been processed, printing may continue for a few pages before being canceled.
- It may take a while to cancel a large print job.

Canceling a print job while printing

1. Press the [Clear/Stop] key.

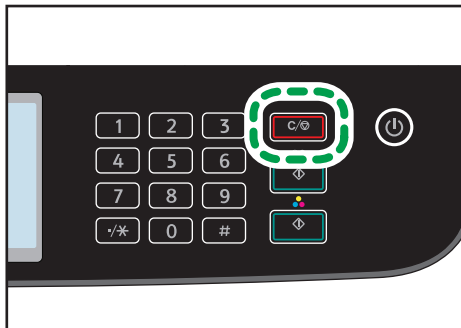

ECC203

2. Press [Print Jobs] on the [Cancel Jobs] screen.

Printing Confidential Documents

By the Locked Print function, you can password-protect print jobs.

This means that your job is printed only after you enter the password using the machine's control panel.

This function prevents unauthorized users from seeing sensitive documents at the machine.

★ Important

- This function is available for M C250FW only.
- This function is only available when using the PCL printer driver, and printing from a computer running a Windows operating system.
- The procedure in this section is an example based on Windows 10.

3

Storing a Locked Print file

This section explains how to store a Locked Print file in the machine using the printer driver.

1. Open the file you want to print on your computer.
2. On the [File] menu, click [Print...].
3. In the [Select Printer] area, select the name of this machine, and then click [Preferences].
4. Click the [Setup] tab, and then select the [Locked Print] check box.

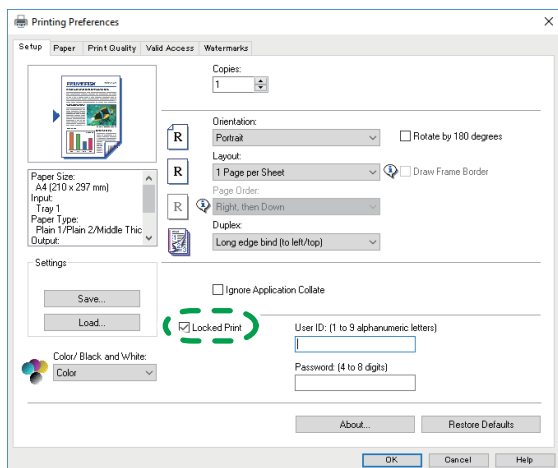

ECC254

The [Password:] and [User ID:] text boxes become available.

The [User ID:] text box contains the login user name of your computer account or the user code used for the previous Locked Print job.

5. Type the password (containing 4 to 8 digits) and user ID (containing 1 to 9 alphanumeric characters), and then click [OK].

The user code will be used to identify your Locked Print file on the machine's control panel.

6. Execute a print command.

The print job is stored in the machine as a Locked Print file. You can print the file by entering the password using the control panel.

Note

- The Locked Print file is automatically erased from the machine's memory when it is printed out, or when the machine's power is turned off.
- The machine can store up to 5 jobs or 5 MB of Locked Print data at a time.
- Even if the machine cannot store any more Locked Print files, the machine holds a new Locked Print file for the period of time specified in [Locked Print] under system settings before canceling the job. Within this time, you can print or delete the new Locked Print file. You can also print or delete an existing Locked Print file so that the new Locked Print file can be stored in the machine.

Printing a Locked Print file

When there is a Locked Print file stored in the machine, "Locked Print Job" appears on the machine's control panel display when the machine is in the copier, fax, scanner, or ID card copy mode.

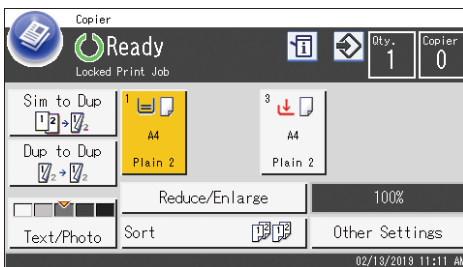

Also, "Locked Print Job" appears on the [Status] screen.

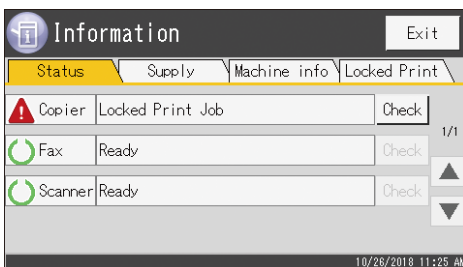

Use the following procedure to unlock and print the Locked Print file.

1. Press the [Home] key.

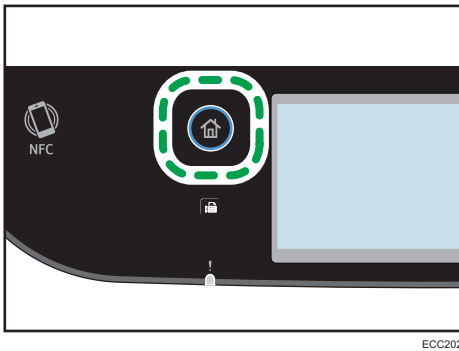

ECC202

2. Press the [Status] icon on the [Home] screen.

3. Press the [Locked Print] tab.

4. Select the file you want to print.

Identify the Locked Print file by checking its time stamp and user ID.

5. Press [Print Jobs].

6. Press the [Locked Print Password:] box.

7. Enter the password, and then press [OK].

8. Press [OK].

Note

- You cannot print a Locked Print file while the machine is currently printing. The machine beeps if you try to do so.
- While entering a password using the control panel, the machine cannot process other print jobs.
- The Locked Print file is automatically erased from the machine's memory when it is printed out, or when the machine's power is turned off.

Deleting a Locked Print file

When there is a Locked Print file stored in the machine, "Locked Print Job" appears on the machine's control panel display when the machine is in the copier, fax, scanner, or ID card copy mode.

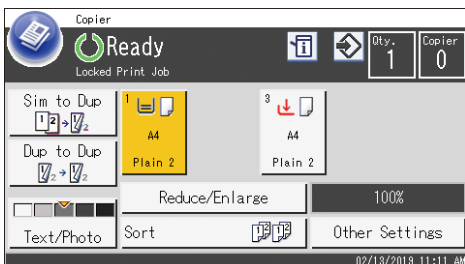

Also, "Locked Print Job" appears on the [Status] screen.

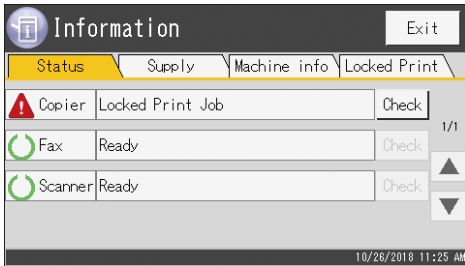

3

Use the following procedure to delete a Locked Print file. You do not need to enter a password to delete a Locked Print file.

1. Press the [Home] key.

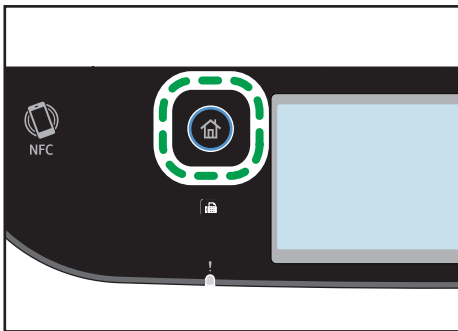

2. Press the [Status] icon on the [Home] screen.
3. Press the [Locked Print] tab.
4. Select the file you want to delete.

Identify the Locked Print file by checking its time stamp and user ID.

5. Press [Delete Jobs].

The Locked Print file is deleted.

Note

- You can also display the Locked Print file list by pressing [Check] on the [Status] tab in Step 3.

Using Various Print Functions

This section briefly describes various print functions that you can configure with the printer driver to make printouts appropriate for your purposes.

Print Quality Functions

Print quality and color tone can be adjusted to suit the print data. Some of the print quality settings you can configure are described below.

Printing color documents in black and white

The black produced in black and white printing is a more distinct black than that produced in color printing.

Separating the print data into CMYK and printing in designated color only

Normally, all four colors (CMYK) are used for color printing. If you do not want to use certain colors, you can disable the use of those colors and print using other colors only.

Saving toner when printing (Economy Color printing)

You can save toner by printing with lower toner consumption.

Changing the image printing method

You can select to print with priority on print quality or print speed. When printing images, the higher the resolution of images is, the longer the time is required for printing.

Changing the dither pattern

A dither pattern is a pattern of dots used to simulate a color or shade of an image. If the pattern is changed, the characteristics of the image will also change. You can select a pattern suitable for the image to be printed.

Changing the color profiling pattern

You can select a color profiling pattern to adjust the tone of colors according to the colors displayed on the computer screen.

Because colors on the computer screen are created using the three RGB colors while colors for printing are composed of the four CMYK colors, colors need to be converted during the printing process. Therefore, images on the printed paper may look different from those on the computer screen if adjustment is not performed.

Printing grayscale images using black or CMYK

You can print black or gray sections of an image using black toner only, instead of using all CMYK toners. Compared to the black printed with CMYK toner, this results in a black that is flatter and purer.

Using ICM (Image Color Matching)

You can use Windows ICM function to reproduce colors that appear on the computer screen as close as they are on printed paper.

To use this function, the color profile must be added to the computer. You can find the color profile in the ICM folder stored on the provided printer driver CD-ROM. For information about adding a color profile, search Windows Help for "color profile", and then see the appropriate topic.

↓ Note

- Some of the functions described above might not be available depending on the printer driver or operating system. For details, see the printer driver Help.

3

Print Output Functions

You can specify the form of print outputs according to your purposes. This section briefly describes some of the settings that you can specify.

Printing multiple sets of a document

You can print multiple sets of the same document.

Collating the output in document batches

You can print complete sets of a multiple-page document one set at a time (P1, P2, P1, P2 ...). If this function is not used when printing multiple sets, prints will be output in page batches (P1, P1, P2, P2 ...). This function is useful when, for example, making presentation materials.

Changing orientation or rotating the image

You can change the orientation of an image to portrait or landscape. You can also rotate the image by 180 degrees. Use rotation to prevent an image from being printed upside down when using paper with a predefined top and bottom (such as letterhead paper).

Printing multiple pages per sheet

You can print multiple pages onto one sheet of paper.

When using this function, a suitable reduction ratio is selected automatically based on the paper size and the number of pages you want to fit on each sheet.

Printing on both sides of paper (duplex printing)

You can print on both sides of paper.

Reducing or enlarging the document

You can reduce or enlarge documents by a specific ratio, from 25% to 400% in 1% increments.

You can also reduce or enlarge documents automatically to fit a specific paper size. This function is useful, for example, when printing Web pages.

If the [Enable Large Papers] option is selected, A3/11 × 17/B4/8K documents can be scaled to a size that the machine supports, so that it can then be printed out.

Not printing of blank pages (only PostScript 3 printer driver)

If a print job contains blank pages, they can be prevented from being printed.

Note that this setting has higher priority than [Blank Page Print] under [Printer Settings] of the control panel.

Printing with a cover page

You can add a cover page to the print job.

You can select to leave the cover page blank, or print the first page of the document on the cover page. If a cover page is inserted into a duplex job, you can print on its back side also.

Paper for the cover page can either be the same as or different from the remaining pages.

Printing on custom size paper

You can print using non-standard size paper by specifying the size of the paper as custom size.

To specify the custom paper size, select [Custom Paper Size] from the [Document Size:] list, and then click the [Custom Paper Size...] button in the lower part of the dialog box to configure the paper size.

Superimposing text on prints (watermark)

You can superimpose watermark text on prints. Various predefined watermarks are provided. You can also create your own watermarks.

Note

- Some of the functions described above might not be available depending on the printer driver or operating system. For details, see the printer driver Help.

4. Copying Originals

This chapter describes the basic and advanced procedures for making copies and how to specify settings.

What You Can Do with the Copier Function

Duplex copying

You can copy two pages onto both sides of a single sheet of paper. For details about the settings, see page 107 "Copying Single-Sided Originals with 2-Sided and Combined Printing" and page 112 "Copying 2-Sided Originals with 2-Sided and Combined Printing".

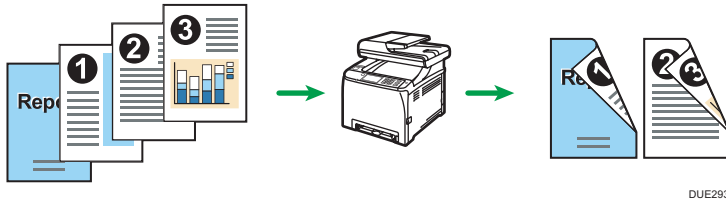

Combined copying

You can copy multiple pages onto a single sheet of paper. For details about the settings, see page 107 "Copying Single-Sided Originals with 2-Sided and Combined Printing" and page 112 "Copying 2-Sided Originals with 2-Sided and Combined Printing".

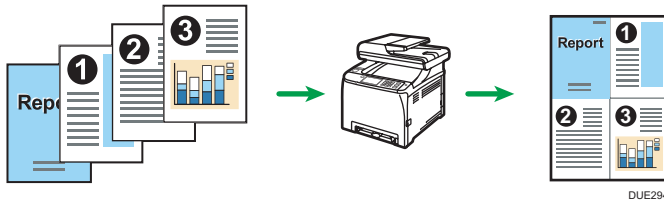

ID card copying

ID card copying allows you to copy the front and back sides of an ID card or passport onto one side of a sheet of paper. For details, see page 117 "Copying an ID Card".

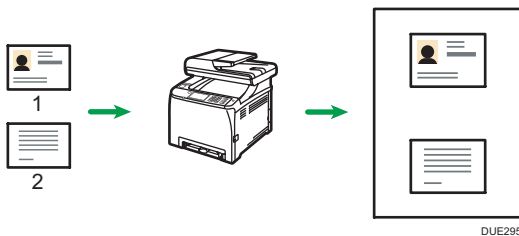

Copier Mode Screen

This section provides information about the screen when the machine is in copier mode.

Screen in standby mode

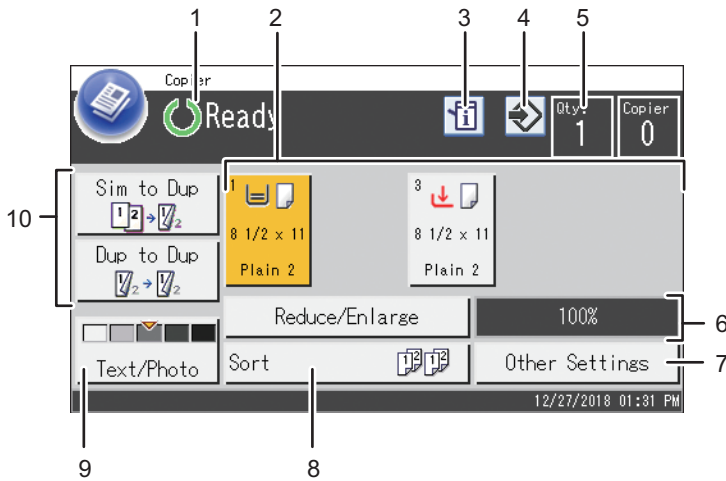

ECC207

1. Current status or messages

Displays the current status or messages.

2. Paper tray status indicators

Displays paper tray settings.

3. Information icon

Press to check the information.

4. Favorite item icon

Press to register current settings to a favorite item.

5. Copy quantity

Displays the numbers of copies set and copies made. You can change the copy quantity using the number keys.

6. Reduce/Enlarge ratio

You can specify the enlargement and reduction ratios if [Reduce/Enlarge] is pressed.

7. [Other Settings]

Press to display the functions you can use.

8. [Sort]

Configures the machine to sort the output pages into sets when making multiple copies of a multipage document.

9. Original and scanning settings

Press to specify the original type and image density level.

10. [Dup to Dup], [Sim to Dup]

Press to set the duplex function.

↓ Note

- The start-up mode can be specified in the [Function Priority] setting under [Administrator Tools]. For details, see page 251 "Administrator Tools Settings".

Basic Operation of Copying

★ Important

- The original in the ADF takes precedence over the original on the exposure glass if you place originals both in the ADF and on the exposure glass.

1. Press the [Home] key.

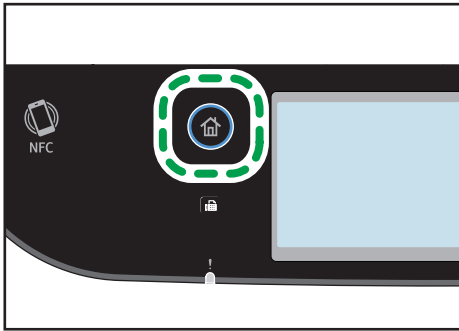

ECC202

2. Press the [Copier] icon on the [Home] screen.

3. Place the original on the exposure glass or in the ADF.

To place the original, see page 76 "Placing Originals". If necessary, configure advanced photocopy settings.

4. To make multiple copies, enter the number of copies using the number keys.

5. Press the [B&W Start] key or [Color Start] key.

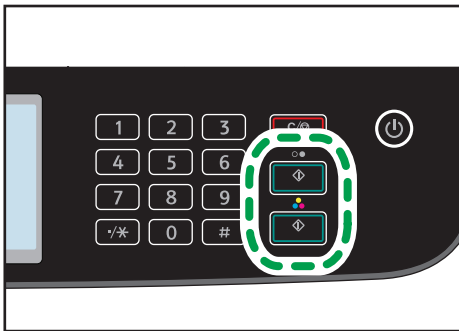

ECC204

To make black-and-white photocopies, press the [B&W Start] key.

To make color photocopies, press the [Color Start] key.

↓ Note

- The maximum number of copies is 99.

- You can change the paper tray for the current job. If tray 2 is installed, you can select to change the paper tray automatically according to the paper size (A4 or Letter).
- You can select the paper tray for printing out copies in [Select Paper] under copy settings. If you set the machine to switch between Tray 1 and 2 automatically depending on the paper size in this setting, you can also specify the tray the machine uses first in [Paper Tray Priority] under [Paper Settings]. For [Select Paper], see page 217 "Copier Settings". For [Paper Tray Priority], see page 246 "Paper Settings".
- When making multiple copies of a multi-page document, you can select whether copies are output in collated sets, or in page batches in the [Sort] setting under copy settings. [Sort] cannot be used with the bypass tray. For [Sort], see page 217 "Copier Settings".
- If a paper jam occurs, printing stops after the current page has been printed out. After the jammed paper is removed, printing restarts from the jammed page automatically.
- If a scanning jam occurs in the ADF, copying is canceled immediately. In this case, copy the originals again starting from the jammed page. For the direction to remove the jammed paper, see page 349 "Removing Paper Jams".

Canceling a Copy

While scanning the original

If copying is canceled while the machine is scanning the original, copying is cancelled immediately and there is no printout.

When the original is set in the ADF, scanning stops immediately but pages that have already been scanned completely will be copied.

While printing

If copying is canceled during printing, the photocopy process is canceled after the current page has been printed out.

Follow the procedure below to cancel copying.

1. Press the [Home] key.

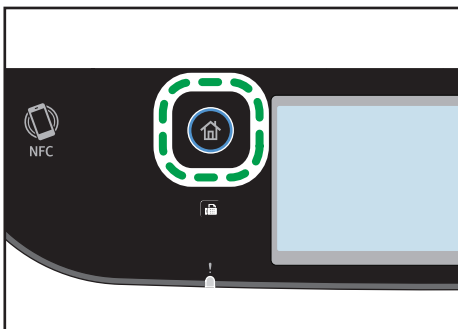

ECC202

2. Press the [Copier] icon on the [Home] screen.
3. Press the [Clear/Stop] key.

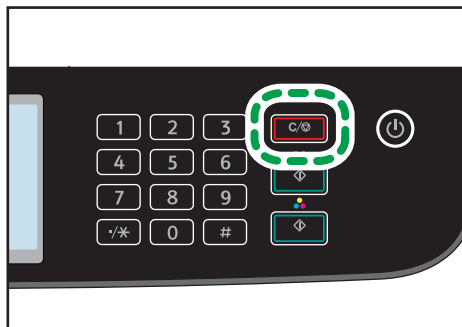

ECC203

4

When the [Cancel Jobs] screen appears, proceed to Step 4.

4. Press [Copy Jobs].

Making Enlarged or Reduced Copies

There are two ways to set the scaling ratio: using a preset ratio or manually specifying a customized ratio.

Preset ratio

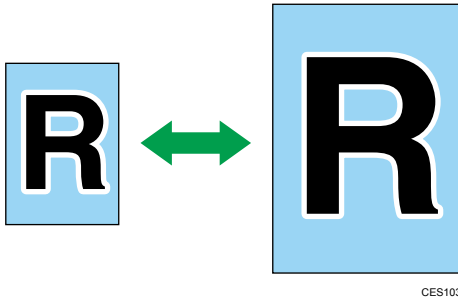

- **Region A** (mainly Europe and Asia)
50%, 71%, 82%, 93%, 122%, 141%, 200%, 400%
- **Region B** (mainly North America)
50%, 65%, 78%, 93%, 129%, 155%, 200%, 400%

Custom ratio



25% to 400% in 1% increments.

Specifying Reduce/Enlarge

1. Press the [Home] key.

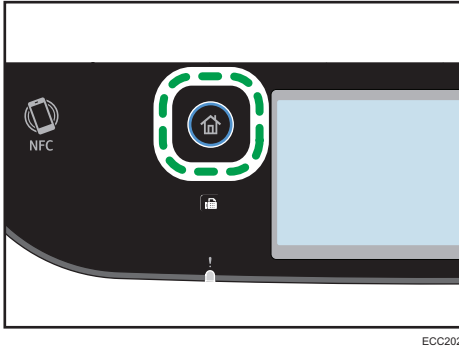

4

2. Press the [Copier] icon on the [Home] screen.
3. Press [Reduce/Enlarge].
4. For [Reduce] and [Enlarge], select the ratio you require. For [Zoom], press [+] or [-] to specify the ratio.
5. Press [OK].

↓ Note

- You can change the machine's default [Reduce/Enlarge] setting to always make photocopies in the specified ratio. For details, see page 217 "Copier Settings".
- Temporary job settings are cleared in the following cases:
 - When no input is received for the period of time specified in [System Reset Timer] while the initial screen is displayed. For details, see page 251 "Administrator Tools Settings".
 - When the [Clear/Stop] key is pressed while the initial screen is displayed.
 - When the machine's mode is changed.
 - When the power is turned off.
 - When the machine's default for the same setting is changed.

Copying Single-Sided Originals with 2-Sided and Combined Printing

This section explains how to combine and print a multiple pages (two or four pages) on one side or both sides of paper.

★ Important





- This function is only available when the original is set in the ADF, not when it is set on the exposure glass.
- To use this function, the paper size used for printing copies must be set to A4, Letter or Legal.
- To use 2-sided copy, the paper size used for printing copies must be set to A4, B5 JIS, Legal, Letter, Executive, 8 × 13, 8¹/₂ × 13, Folio, 16K, Government Legal, or Indian Legal.
- The paper for 2-sided copy is fed from Tray 1 or 2, but not from the bypass tray.
- The types of paper that can be used for 2-sided copy are plain 1, plain 2, middle thick, recycled, color, preprinted, and prepunched.

There are following copy modes. Select a copy mode according to your original and how you want the copy outputs to appear.

Combined copy on one side

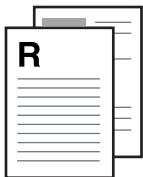





In this mode, a two or four-page original is combined and printed on one side of paper.

1S 2Org->Cmb 2on1 1S

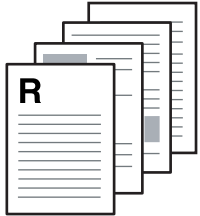
	Original	Copy
Portrait		
Landscape		

CMF250

1S 4Org->Cmb 4on1 1S







	Original	Copy	
Portrait		Left to Right 	Top to Bottom 
Landscape		Left to Right 	Top to Bottom 

CMF251

Combined copy on both sides

In this mode, a multiple-page original is combined and printed on both sides of paper.

1S 4Org->Cmb 2on1 2S

	Original	Copy	
Portrait		Top to Top 	Top to Bottom 
Landscape		Top to Top 	Top to Bottom 

DUE331

1S 8Org->Cmb 4on1 2S

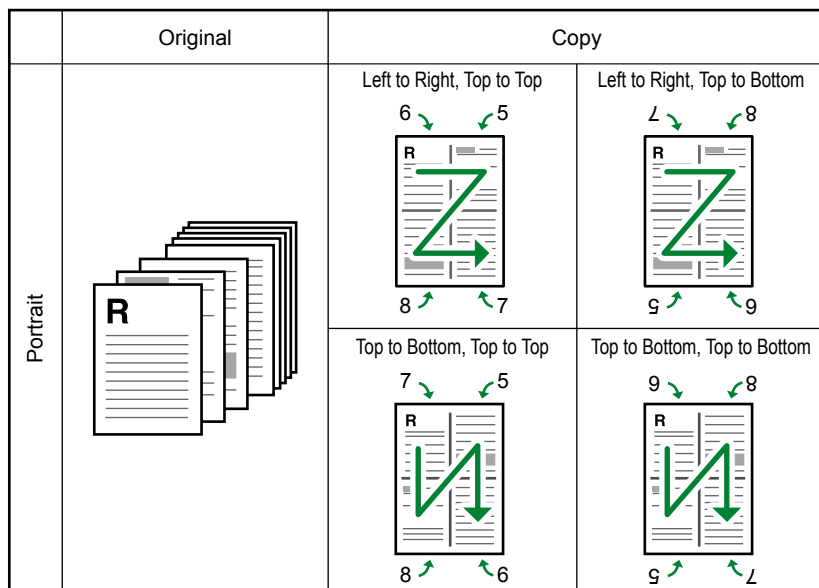



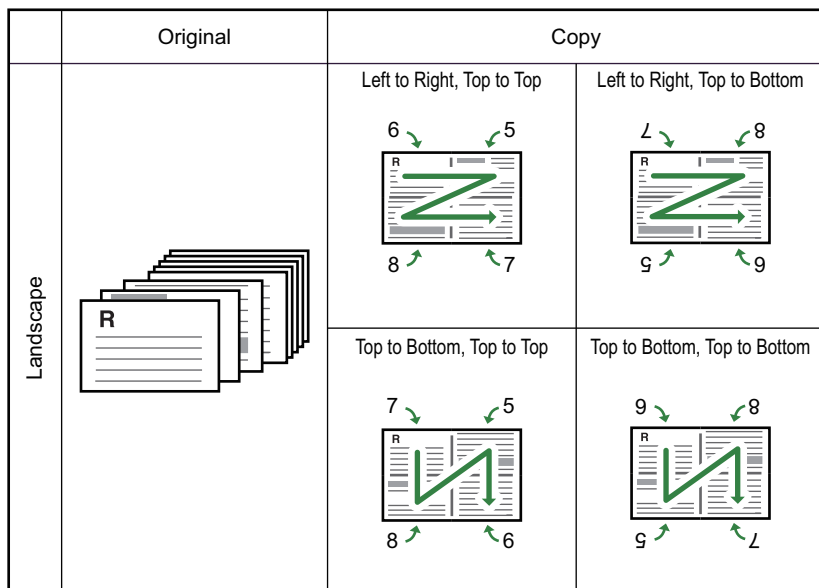

CMF255

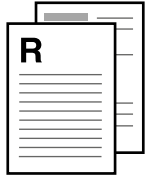

DCT004

1S Orig->2S Copy

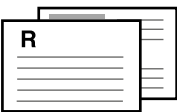
In this mode, one-sided pages are printed on the front and back sides of paper without being combined.

	Original	Copy	
Portrait		Top to Top 	Top to Bottom 
Landscape		Top to Top 	Top to Bottom 

CMF260

Specifying Combined and 2-sided Copies

1. Press the [Home] key.

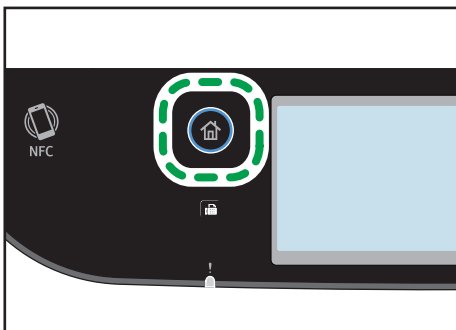

ECC202

2. Press the [Copier] icon on the [Home] screen.
3. Press [Other Settings].
4. Press [Simplex to Duplex].
5. Select the desired copy mode, and then press [OK].
6. Press [OK].

↓ Note

- Setting combined and 2-sided copying automatically disables the [ID Card Copy] setting.

- You can change the machine's default [Duplex/Combine] setting to always make photocopies in the specified ratio. For details, see page 217 "Copier Settings".
- Temporary job settings are cleared in the following cases:
 - When no input is received for the period of time specified in [System Reset Timer] while the initial screen is displayed. For details, see page 251 "Administrator Tools Settings".
 - When the [Clear/Stop] key is pressed while the initial screen is displayed.
 - When the machine's mode is changed.
 - When the power is turned off.
 - When the machine's default for the same setting is changed.

Copying 2-Sided Originals with 2-Sided and Combined Printing

This section explains how to make 2-sided copies of 2-sided originals, or copy two original pages to one sheet, or copy four original pages to one sheet with two pages per side.

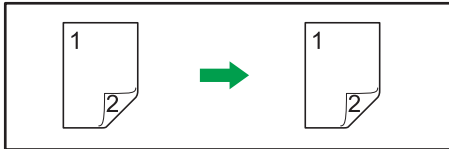

DAC602



DAC603

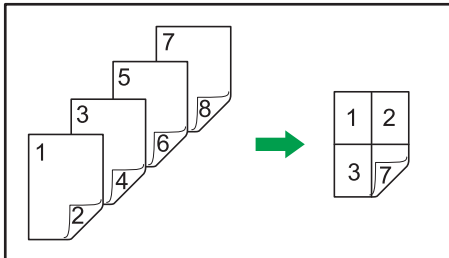

DAC603

★ Important

- [2S 1Org->Cmb 2on1 1S], [2S 2Org->Cmb 4on1 1S], [2S Orig->2S Copy], [2S 2Org->Cmb 2on1 2S], or [2S 4Org->Cmb 4on1 2S] is available for copying using the ADF, but not using the exposure glass.
- Copy to the front and back of the sheet in the same color mode. If you try to copy in a different mode, an alarm sounds.
- Make sure the same number of pages will be printed on the front and back of all sheets. Otherwise, the job will be reset.

The following five types of manual 2-sided copying are available.

2S 1Org->Cmb 2on1 1S

Copies one 2-sided original to one side of a sheet.

2S 2Org->Cmb 4on1 1S

Copies two 2-sided originals to one side of a sheet.

2S Orig->2S Copy

Makes 2-sided copies of 2-sided originals.

2S 2Org->Cmb 2on1 2S

Copies both sides of one 2-sided original to one side of a sheet, and both sides of another 2-sided original to the other side of the sheet.

2S 4Org->Cmb 4on1 2S

Copies four 2-sided originals to one sheet with four pages per side.

Manual 2Sd Scan Mode

Select this mode to make 2-sided copies using the exposure glass.

Duplex Copying Using the ADF

1. Press the [Home] key.

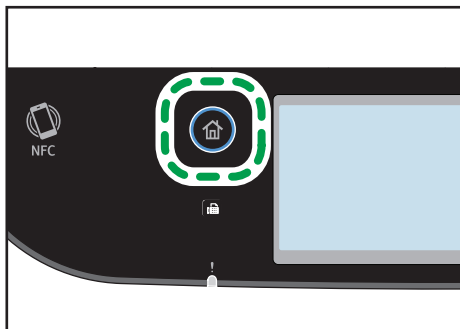

ECC202

2. Press the [Copier] icon on the [Home] screen.
3. Press [Other Settings].
4. Press [Duplex to Duplex].
5. Select the desired copy mode, and then press [OK].
6. Press [OK].

7. Place all 2-sided originals into the ADF with their fronts facing up.

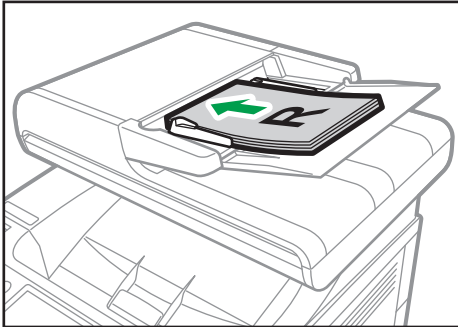

ECC122

4

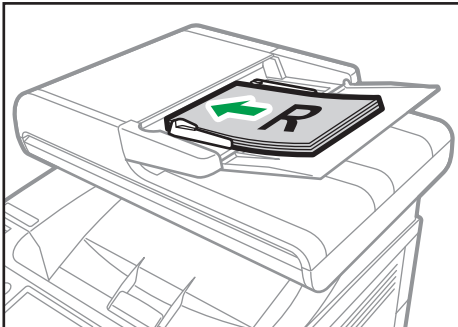

ECC124

8. Press the [B&W Start] key or [Color Start] key.

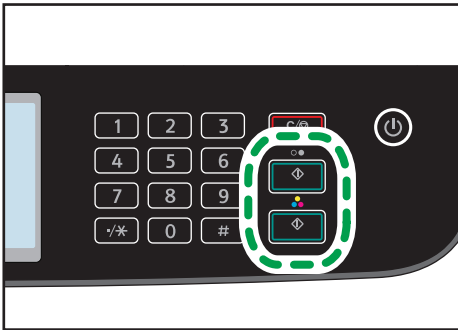

ECC204

To make black-and-white photocopies, press the [B&W Start] key.

To make color photocopies, press the [Color Start] key.

Use the same mode (color or black-and-white) for both sides.

After all pages have been scanned, copying starts.

↓ Note

- After you place the originals, press the [B&W Start] key or [Color Start] key within the time specified in [System Reset Timer]. Otherwise, the job is canceled. For details, see page 251 "Administrator Tools Settings".
- If the memory becomes full while originals are being scanned, the job is canceled.

Duplex Copying Manually Using the Exposure Glass

★ Important

- When printing odd pages in [Manual 2Sd Scan Mode], the last page cannot be printed. Before printing the last page, set the [Duplex/Combine] to [Off].

1. Press the [Home] key.

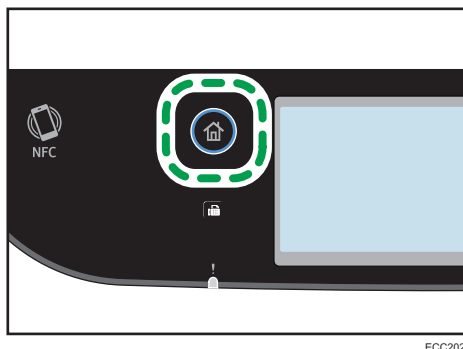

2. Press the [Setting] icon on the [Home] screen.
3. Press [Copier Settings].
4. Press [▼].
5. Press [Duplex/Combine].
6. Press [▼].
7. Press [Manual 2Sd Scan Mode].
8. Press the [Home] key.
9. Press the [Copier] icon on the [Home] screen.
10. Place the original on the exposure glass front side down and with the top to the rear of the machine.
Place the originals one by one.
11. Press the [B&W Start] key or [Color Start] key.

A message prompting you to place the original back side down on the exposure glass appears on the display.

12. Place the original on the exposure glass with the back side faced down and with the top to the rear of the machine.

13. Press [Start].

Use the same mode (color or black-and-white) for both sides.

When all originals have been scanned, press [Job Finished].

↓ Note

- After you load the original, press the [B&W Start] key or [Color Start] key within the time specified in [System Reset Timer]. Otherwise, the job is canceled. For details, see page 251 "Administrator Tools Settings".
- Sort is not available.

Copying an ID Card

This section describes how to copy the front and back sides of an ID card or other small documents onto one side of a sheet of paper.

★ Important

- This function is available only when the original is set on the exposure glass, not when it is set in the ADF.
- To use this function, the paper size used for printing copies must be set to A6, A5, A4, or Letter.

Printed paper size	Scanned paper size
A4	A5 (148×210 mm)
Letter	Half Letter (140×216 mm)
A5	A6 (105×148 mm)
A6	A7 (74×105 mm)

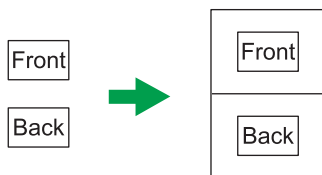

DUE332

1. Press the [Home] key.

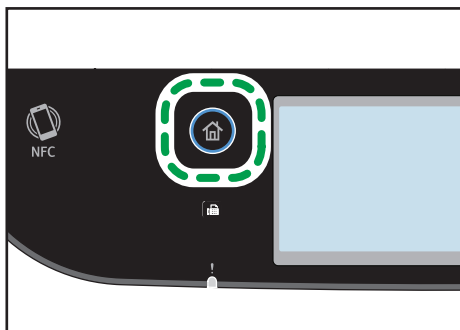

ECC202

2. Press the [Card] icon on the [Home] screen.
3. To make multiple copies, enter the number of copies using the number keys.

4. Place the original in the upper-left corner of the exposure glass.

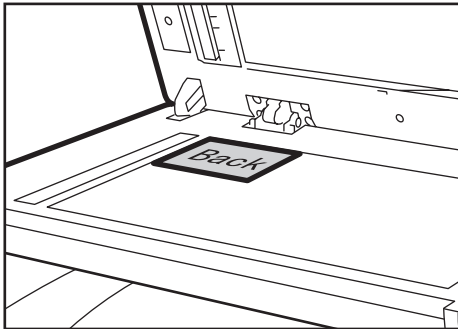

DUE241

4

5. Press the [B&W Start] key or [Color Start] key.

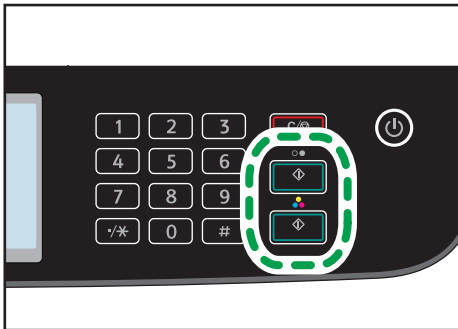

ECC204

A message prompting you to place the original back side down on the exposure glass appears on the display.

6. Place the original on the exposure glass with the back side faced down, and then press [Start].

Use the same mode (color or black-and-white) for both sides.

↓ Note

- For the ID card copy function, you can set the machine to print a line in the middle of the printed paper. Specify [Center Line] under [Copier Settings].
- You can change the scanning size for the ID card function. Specify [Card Size] under [Copier Settings].
- After you load the originals, press the [B&W Start] key or [Color Start] key within the time specified in [System Reset Timer]. Otherwise, the job is canceled. For details, see page 251 "Administrator Tools Settings".
- Regardless of the machine's reduction or enlargement ratio setting, an ID card copy will always be made at 100%.
- Temporary job settings are cleared in the following cases:

- When no input is received for the period of time specified in [System Reset Timer] while the initial screen is displayed. For details, see page 251 "Administrator Tools Settings".
- When the [Clear/Stop] key is pressed while the initial screen is displayed.
- When the machine's mode is changed.
- When the power is turned off.
- When the machine's default for the same setting is changed.

Specifying Scan Settings for Copying

This section describes how to specify image density and scan quality for the current job.

Adjusting Image Density

There are five image density levels. The higher the density level, the darker the printout.

1. Press the [Home] key.

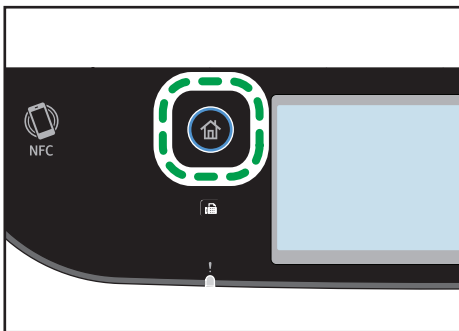

2. Press the [Copier] icon on the [Home] screen.
3. Press [Text/Photo].
4. Press [◀] or [▶] to select the desired density level, and then press [OK].

↓ Note

- You can change the machine's default [Density] setting to always make copies with a specific density level. For details, see page 217 "Copier Settings".
- Temporary job settings are cleared in the following cases:
 - When no input is received for the period of time specified in [System Reset Timer] while the initial screen is displayed. For details, see page 251 "Administrator Tools Settings".
 - When the [Clear/Stop] key is pressed while the initial screen is displayed.
 - When the machine's mode is changed.
 - When the power is turned off.
 - When the machine's default for the same setting is changed.

Selecting the Document Type According to Original

There are three document types:

Text/Photo

Select this when the original contains both text and photographs or pictures.

Text

Select this when the original contains only text and no photographs or pictures.

Photo

Select this when the original contains only photographs or pictures. Use this mode for the following types of original:

- Photographs
- Pages that are entirely or mainly photographs or pictures, such as magazine pages.

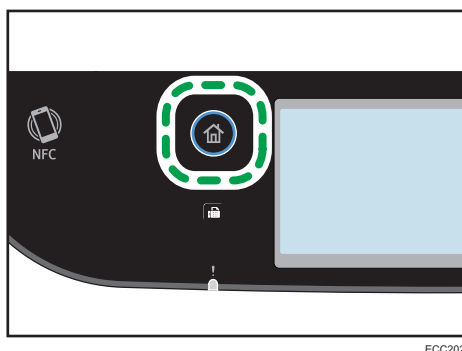
1. Press the [Home] key.**2. Press the [Copier] icon on the [Home] screen.****3. Press [Text/Photo].****4. Select the desired document type, and then press [OK].****Note**

- You can change the machine's default [Original Type] setting to always make copies with a specific document type. For details, see page 217 "Copier Settings".
- Temporary job settings are cleared in the following cases:
 - When no input is received for the period of time specified in [System Reset Timer] while the initial screen is displayed. For details, see page 251 "Administrator Tools Settings".
 - When the [Clear/Stop] key is pressed while the initial screen is displayed.
 - When the machine's mode is changed.
 - When the power is turned off.
 - When the machine's default for the same setting is changed.

5. Scanning Originals

This chapter describes how to specify settings and use the scanner function.

What You Can Do with the Scanner Function

Send Scanned Documents to a Folder on a Client Computer

For details, see "Basic Operation of Scan to Folder".



Send Scanned Documents by E-mail

For details, see "Basic Operation of Scan to E-mail".



Saving Scan Files on a USB Flash Memory Device

For details, see "Basic Procedures for Saving Scan Files on a USB Flash Memory Device".

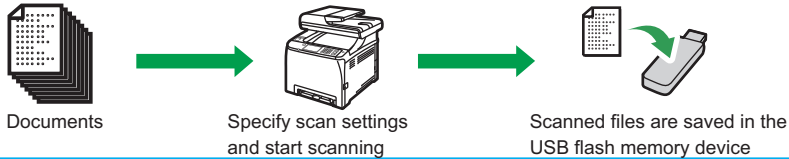

Scanning Documents from RICOH Scan Utility V2

For details, see "Basic Operation for RICOH Scan Utility V2".

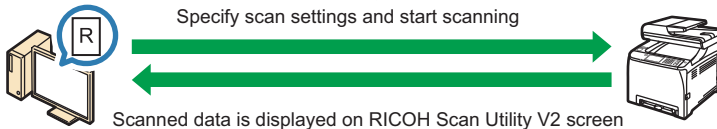

Scanning Documents from a Client Computer

For details, see "Basic Operation for TWAIN Scanning".

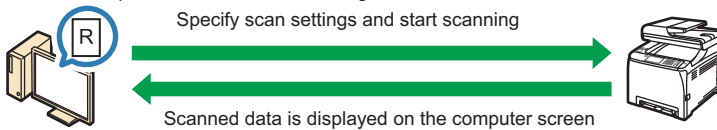

Scanner Mode Screen

This section provides information about the screen in scanner mode.

Screen in standby mode

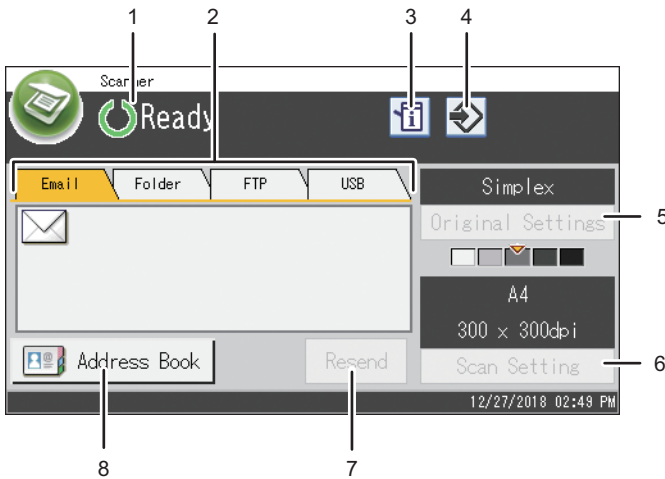

ECC208

1. Current status or messages

Displays the current status or messages.

2. Email / Folder / FTP / USB

Press these tabs to switch between the [Email] screen, [Scan to Folder] screen, [Scan to FTP] screen, and [Scan to USB] screen.

- When [Email] is selected, you can specify e-mail destinations.
- When [Folder] is selected, you can specify folder destinations.
- When [FTP] is selected, you can send scanned documents to an FTP server.
- When [USB] is selected, you can save scanned files to the USB flash memory device inserted into the machine.

3. Information icon

Press to check the information.

4. Favorite item icon

Press to register current settings to a favorite item.

5. Original Settings

Allows you to specify original settings.

6. Scan Settings

Allows you to specify scan settings.

7. Resend

Press this to specify the last used destination as the destination for the current job.

8. Address Book

Allows you to recall destinations registered in the machine.

Note

- The machine's default mode at power on can be specified in the [Function Priority] setting under [Administrator Tools] For [Function Priority], see page 251 "Administrator Tools Settings".

Registering Scan Destinations

This section describes how to register scan destinations in the Address Book. To send scanned files to an e-mail address (Scan to E-mail), FTP server (Scan to FTP), or a shared folder on a network computer (Scan to Folder), you must first register the destination in the Address Book using Web Image Monitor.

★ Important

- **The Address Book data could be damaged or lost unexpectedly. The manufacturer shall not be responsible for any damages resulting from such data loss. Be sure to create backup files of the Address Book data periodically.**
- **Depending on your network environment, the Scan to FTP and Scan to Folder functions may require a user name and password to be correctly entered in the destination information. In such cases, after registering destinations, check that the user name and password are correctly entered by sending test documents to those destinations.**

5

The Address Book can contain up to 100 entries, including 20 Quick Dial entries.

Destinations registered as Quick Dial entries can be selected by pressing the corresponding button in the Address Book.

1. **Start the web browser and access the machine by entering its IP address.**
2. **Click [Quick Dial Destination] or [Scan Destination].**
3. **From the [Destination Type] list, select [E-mail Address], [FTP], or [Folder].**
4. **Register information as necessary.**

The information you must register varies depending on the destination type. For details, see the tables below.

5. **Enter the administrator password if required.**
6. **Click [Apply].**
7. **Close the web browser.**

Scan to E-mail Settings



Program/Change E-mail Address Destination

- Quick Dial Number:
- Name (Required):
- Destination E-mail Address (Required):
- Notification E-mail Address (Optional):
- Subject (Required):
- Sender's Name (Optional):
- File Format (Color/Gray Scale): PDF TIF
- File Format (Black & White): TIF PDF
- Original: 1 Sided
- Scan Size: A4 210 x 297
- Resolution: 300 x 300dpi
- Density:

Please enter Administrator Password:



Apply Cancel

Item	Setting	Description
Quick Dial Number	Optional	Select when setting the destination as a Quick Dial entry.
Name	Required	Name of the destination. The name specified here will be shown on the screen when selecting a scan destination. Can contain up to 16 characters.
Destination E-mail Address	Required	E-mail address of the destination. Can contain up to 64 characters.
Notification E-mail Address	Optional	E-mail address to which a notification is sent after transmission. Can contain up to 64 characters.
Subject	Required	Subject of the e-mail. Can contain up to 64 characters.
Sender's Name	Optional	Name of e-mail sender. The name specified here will be shown under "From" or a similar field of the recipient's email application. Can contain up to 32 characters.
File Format (Color/Gray Scale)	Required	File format of the scanned file when scanning in color. PDF or JPEG can be selected. PDF supports multiple pages in a document, but JPEG does not.
File Format (Black & White)	Required	File format of the scanned file when scanning in black and white. PDF or TIFF can be selected. Both formats support multiple pages in a document.

Item	Setting	Description
Original	Required	Select the sides of the original (1 side or 2-sides) to scan according to the page and binding orientation.
Scan Size	Required	Select the scanning size for the original from A5, B5, A4, 7 ¹ / ₄ × 10 ¹ / ₂ , 8 ¹ / ₂ × 5 ¹ / ₂ , 8 ¹ / ₂ × 11, 8 ¹ / ₂ × 14, or custom size. If you select custom size, select [mm] or [Inch], and then specify the width and length.
Resolution	Required	Select the scan resolution from 100×100, 150×150, 200×200, 300×300, 400×400, or 600×600 dpi.
Density	Required	Specify the image density by clicking the right or left button.  is the lightest, and  is the darkest.

Scan to FTP Settings

Item	Setting	Description
Quick Dial Number	Optional	Select when setting the destination as a Quick Dial entry.
Name	Required	Name of the destination. The name specified here will be shown on the screen when selecting a scan destination. Can contain up to 16 characters.
Hostname or IP Address	Required	Name or IP address of the FTP server. Can contain up to 64 characters.

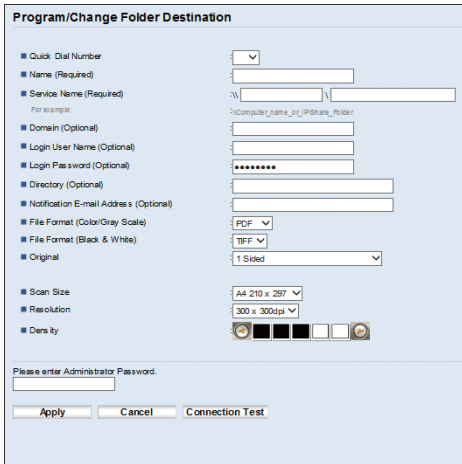

Item	Setting	Description
File Format (Color/Gray Scale)	Required	File format of the scanned file when scanning in color. PDF or JPEG can be selected. PDF supports multiple pages in a document, but JPEG does not.
File Format (Black & White)	Required	File format of the scanned file when scanning in black and white. PDF or TIFF can be selected. Both formats support multiple pages in a document.
FTP User Name	Optional	User name for logging in to the FTP server. Can contain up to 32 characters.
FTP Password	Optional	Password for logging in to the FTP server. Can contain up to 32 characters.
Directory	Optional	Name of the FTP server directory where scanned files are stored. Can contain up to 64 characters.
Notification E-mail Address	Optional	E-mail address to which a notification is sent after transmission. Can contain up to 64 characters.
Original	Required	Select the sides of the original (1 side or 2-sides) to scan according to the page and binding orientation.
Scan Size	Required	Select the scanning size for the original from A5, B5, A4, $7\frac{1}{4} \times 10\frac{1}{2}$, $8\frac{1}{2} \times 5\frac{1}{2}$, $8\frac{1}{2} \times 11$, $8\frac{1}{2} \times 14$, or custom size. If you select custom size, select [mm] or [Inch], and then specify the width and length.
Resolution	Required	Select the scan resolution from 100×100, 150×150, 200×200, 300×300, 400×400, or 600×600 dpi.
Density	Required	Specify the image density by clicking the right or left button.  is the lightest, and  is the darkest.
Connection Test	-	A connection test is performed to check whether the specified FTP server exists.

Scan to Folder Settings



5

Item	Setting	Description
Quick Dial Number	Optional	Select when setting the destination as a Quick Dial entry.
Name	Required	Name of the destination. The name specified here will be shown on the screen when selecting a scan destination. Can contain up to 16 characters.
Service Name	Required	Path to the directory where scanned files will be stored. Consists of the IP address or name of the destination computer (can contain up to 64 characters), and name of the shared folder (can contain up to 32 characters).
Domain	Optional	Specify the name of the domain to which the computer belongs. Can contain up to 15 characters.
Login User Name	Optional	User name for logging in to the destination computer. Can contain up to 32 characters.
Login Password	Optional	Password for logging in to the destination computer. Can contain up to 32 characters.
Directory	Optional	Directory within the shared folder for storing scanned files. Can contain up to 64 characters.
Notification E-mail Address	Optional	E-mail address to which a notification is sent after transmission. Can contain up to 64 characters.

Item	Setting	Description
File Format (Color/Gray Scale)	Required	File format of the scanned file when scanning in color. PDF or JPEG can be selected. PDF supports multiple pages in a document, but JPEG does not.
File Format (Black & White)	Required	File format of the scanned file when scanning in black and white. PDF or TIFF can be selected. Both formats support multiple pages in a document.
Original	Required	Select the sides of the original (1 side or 2-sides) to scan according to the page and binding orientation.
Scan Size	Required	Select the scanning size for the original from A5, B5, A4, $7\frac{1}{4} \times 10\frac{1}{2}$, $8\frac{1}{2} \times 5\frac{1}{2}$, $8\frac{1}{2} \times 11$, $8\frac{1}{2} \times 14$, or custom size. If you select custom size, select [mm] or [Inch], and then specify the width and length.
Resolution	Required	Select the scan resolution from 100×100, 150×150, 200×200, 300×300, 400×400, or 600×600 dpi.
Density	Required	Specify the image density by clicking the right or left button.  is the lightest, and  is the darkest.
Connection Test	-	A connection test is performed to check whether the specified FTP server exists.

Note

- To send files via e-mail, SMTP and DNS settings must be configured properly.
- If you are using the Scan to E-mail function, select a time zone according to your geographic location to send email with correct transmission date and time.
- To send files to an FTP server or computer, the user name, password, and directory must be configured properly.
- On a network that uses a DNS server, specify a computer name in [Service Name] and the name of the domain to which the computer belongs in [Domain]. In this case, also configure the DNS related settings using Web Image Monitor.
- The Scan to Folder destination must operate on one of the following operating systems: Windows 7/8.1/10, Windows Server 2008/2008 R2/2012/2012 R2/2016, or OS X 10.10 or later.
- Scan destinations cannot be registered using the control panel.

Modifying Scan Destinations

This section describes how to modify the information of registered destinations.

1. Start the web browser and access the machine by entering its IP address.
2. Click [Scan Destination].
3. Click the [E-mail Address], [FTP], or [Folder] tab.
4. Select the entry to modify, and then click [Change].
5. Modify settings as necessary.
6. Enter the administrator password if required.
7. Click [Apply].
8. Close the web browser.

↓ Note

- You can unassign a Quick Dial entry from the [Quick Dial Destination] page. To do this, select the desired entry, click [Delete], and then click [Apply] again on a confirmation page.
- The machine will notify you if the destination you want to modify is set as a forwarding destination of received faxes. For details about fax forwarding settings, see page 280 "Fax Tab".

Deleting Scan Destinations

This section describes how to delete registered destinations.

1. Start the web browser and access the machine by entering its IP address.
2. Click [Scan Destination].
3. Click the [E-mail Address], [FTP], or [Folder] tab.
4. Select the entry to delete, and then click [Delete].
5. Confirm that the entry you have selected is the entry that you want to delete.
6. Enter the administrator password if required.
7. Click [Apply].
8. Close the web browser.

↓ Note

- The machine will notify you if the destination you want to delete is set as a forwarding destination of received faxes. If you delete the destination anyway, reconfigure the fax forwarding setting. For details about fax forwarding settings, see page 280 "Fax Tab".

Testing Transmission

★ Important

- When a USB flash memory device is inserted into the machine, scanned documents will be stored in the USB flash memory device. Confirm that there are no USB flash memory devices inserted into the machine.
1. Place the original on the exposure glass or in the ADF.
 2. Press the [Home] key.

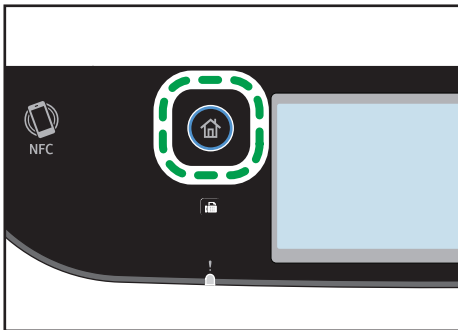

ECC202

3. Press the [Scanner] icon on the Home screen.
4. Press [Address Book].
5. Select the desired destination, and then press [OK].

When you select a destination, a check mark appears against the selected destination.

When you specify a scan destination, the machine's scan settings change automatically according to the information registered for that destination in the Address Book. If necessary, you can change the scan settings using the control panel. For scan settings, see page 167 "Specifying Scan Settings for Scanning".

6. Press the [B&W Start] key or [Color Start] key.

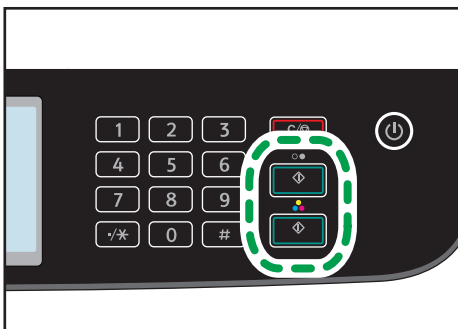

ECC204

To scan in black and white, press the [B&W Start] key.

To scan in color, press the [Color Start] key.

Depending on the machine's settings, you may see the following screen on the display when scanning from the exposure glass.

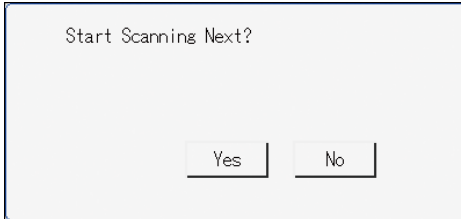

If you see this screen, proceed to the next step.

7. **If you have more originals to scan, place the next original on the exposure glass, and then press [Yes]. Repeat this step until all originals are scanned.**
8. **When all originals have been scanned, press [No] to start sending the scanned file.**

Scanning starts and scanned documents will be stored in a shared folder.

Note

- If the machine fails to transmit the file, confirm the following items.
 - The destination is registered to the Address Book correctly.
 - Disable the security software or firewall of the destination computer and try the job again. For details about security software or the firewall settings, contact your network administrator.
 - If there are several destination computers, test the job with other computers. Compare the settings with the computer the file was transmitted from. For details, contact your network administrator.
 - There is enough disk space on the destination computer.

Basic Operation of Scan to Folder

This section explains the preparations and procedures to send scanned documents to a folder on a client computer.

After following the procedures below, you can send scanned documents from the machine to a shared folder on a client computer.

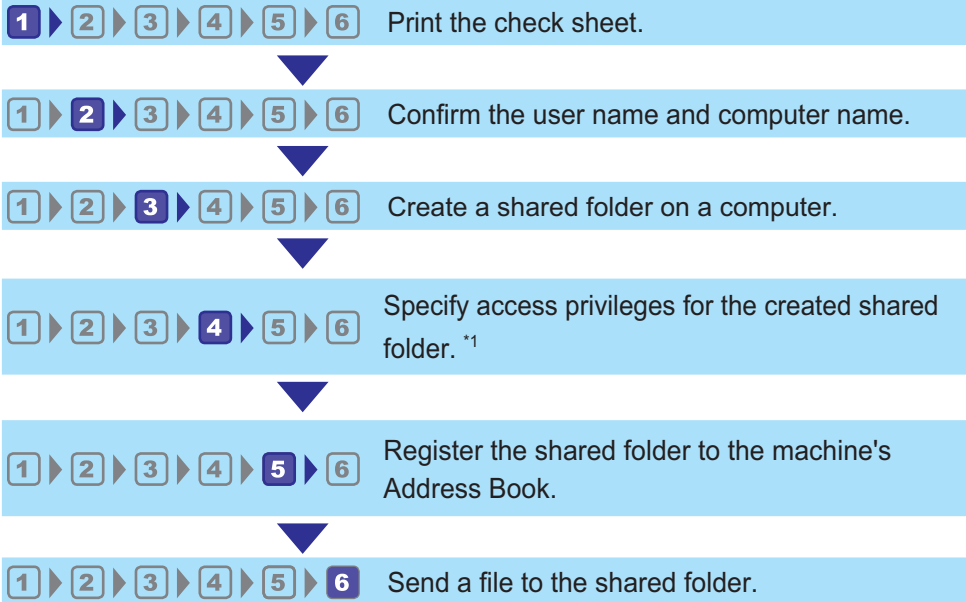

*1 only Windows

↓ Note

- You can create the shared folder under Windows 7 or later, Windows Server 2008 or later, and OS X 10.10 or later.
- Files can be sent via SMB using the SMB (139/TCP, 137/UDP) or CIFS (445/TCP) protocol.
- Files can be sent via SMB (139/TCP, 137/UDP) in a NetBIOS over TCP/IP environment only.
- Files cannot be sent via SMB in a NetBEUI environment.

1 Printing the Check Sheet

Print out the following check sheet. Write on the check sheet the settings for the computer to which you will send documents.

For details about how to use the check sheet to make a list of the setting values, see page 136 "2 Confirming the User Name and Computer Name" and page 138 "3 Creating a Shared Folder on a Computer".

★ Important

- After registering scan destinations to the Address Book, discard the completed check sheet to prevent leakage of personal information.

Check Sheet

No.	Check Item (Entry Example)	Entry Column
[1]	Computer name (ex. YamadaPC)	
	Active settings of DHCP server ([Yes] or [No])	
	Computer's IP address (ex. 192.168.0.152)	
[2]	Domain Name/Working Group Name (ex. ABCD-NET)	USERDNSDOMAIN
		USERDOMAIN
	Computer's user name (ex. TYamada)	
[3]	Computer's login password (ex. Administrator)	
[4]	Computer's shared folder name (ex. scan)	

↓ Note

- Depending on the network environment, USERDNSDOMAIN or USERDOMAIN may not be displayed. Write the domain name or working group name in the check sheet.

2 Confirming the User Name and Computer Name**Confirming the User Name and Computer Name When Running Microsoft Windows**

Confirm the user name and the name of the computer you will send scanned documents to.

1. On the [Start] menu, click [Windows System], and then click [Command Prompt].

2. Enter the command "ipconfig /all", and then press the [Enter] key.
3. Confirm the name of the computer, the active settings of the DHCP server, and the IPv4 address, and then write them in [1] on the check sheet.

The computer's name is displayed under [Host Name].

The address displayed under [IPv4 Address] is the IPv4 address of the computer.

Active settings of DHCP server are displayed under [DHCP Enabled].

4. Next, enter the command "set user", and then press the [Enter] key.
Be sure to put a space between "set" and "user".
5. Confirm the domain name/working group name and the user name, and then write them in [2] on the check sheet.

The user name is displayed under [USERNAME].

Confirm the computer's login password and write it in [3] on the check sheet.

Next, create a shared folder on a computer. For details about creating a shared folder, see page 138 "3 Creating a Shared Folder on a Computer".

Note

- Depending on the operating system or security settings, it might be possible to specify a user name that does not have a password assigned. However, we recommend that for greater security you select a user name that has a password.

Confirming the User Name and Computer Name When Running OS X/macOS

Confirm the user name and the name of the computer you will send scanned documents to. Confirm the values, and then write them on the check sheet.

1. On the Apple menu, click [About This Mac].
The computer's information screen appears.
2. Click [System Report...].
3. In the left pane, click [Software], and then confirm the computer name and user name under "System Software Overview:".

The computer name is displayed next to [Computer Name].

The user name is displayed next to [User Name].

On the check sheet, write the computer name in [1] and the user name in [2].

Next, create a shared folder on a computer. For details about creating a shared folder, see page 138 "3 Creating a Shared Folder on a Computer".

Note

- Depending on the operating system or security settings, you might be able to specify a user name that does not have a password assigned. However, we recommend that you select a user name that has a password.
- To confirm the IP address on the Apple menu, click [System Preferences...], and then click [Network] on the System Preferences window. Then click [Ethernet] or [Wi-Fi]. The address displayed in the IP address field is the IP address of the computer.

3 Creating a Shared Folder on a Computer**Creating a Shared Folder on a Computer Running Microsoft Windows**

5

Create a shared destination folder in Windows and enable sharing. In the following procedure, a computer which is running under Windows 10 Ultimate and participating in a domain is used as an example.

★ Important

- You must log in as an Administrators group member to create a shared folder.
- If "Everyone" is left selected in Step 6, the created shared folder will be accessible by all users. This is a security risk, so we recommend that you give access rights only to specific users. Use the following procedure to remove "Everyone" and specify user access rights.

1. Create a folder, just as you would create a normal folder, in a location of your choice on the computer. Write the folder name in [4] on the check sheet.
2. Right-click the folder, and then click [Properties].
3. On the [Sharing] tab, select [Advanced Sharing...].
4. Select the [Share this folder] check box.
5. Click [Permissions].
6. In the [Group or user names:] list, select "Everyone", and then click [Remove].
7. Click [Add...].

In the [Select Users or Groups] window, add groups or users to whom you want to grant access. In the following procedure, the procedure to give access privileges to users that you wrote on the check sheet is used as an example.

8. In the [Select Users or Groups] window, click [Advanced...].
9. Specify one or more object types, select a location, and then click [Find Now].
10. From the list of results, select the groups and users you want to grant access to (the name you wrote in [2] on the check sheet), and then click [OK].
11. In the [Select Users or Groups] window, click [OK].

12. In the [Group or user names:] list, select a group or user (the name you wrote in [2] on the check sheet), and then, in the [Allow] column of the permissions list, select either the [Full Control] or [Change] check box.

Configure the access permissions for each group and user.

13. Click [OK] 2 times.
14. Click [Close].

If you want to specify access privileges for the created folder to allow other users or groups to access it, proceed to page 140 "4 Specifying Access Privileges for the Created Shared Folder".

If not, proceed to page 140 "5 Registering a Shared Folder in the Machine's Address Book".

Creating a Shared Folder on a Computer Running OS X/macOS

The following procedures explain how to create a shared folder on a computer running OS X or macOS, and how to confirm the computer's information. macOS 10.13 is used in these examples.

★ Important

- You must log in as an administrator to create a shared folder.
1. Create the folder that you want to send scan files to.
Write the folder name into [4] in the check sheet.
 2. On the Apple menu, click [System Preferences...].
 3. Click [Sharing].
 4. Select the [File Sharing] check box.
 5. Click [Options...].
 6. Select the [Share files and folders using SMB] check box.
 7. Select the account that will be used to access the shared folder.
 8. If the [Authenticate] screen appears, enter the password for the account, click [OK], and then click [Done].
 9. Under the [Shared Folders:] list, click [+].
 10. Select the folder you have created, and then click [Add].
 11. Make sure that the permissions for the user who will access this folder are set to [Read & Write].

Next, register scan destinations. For details about registering scan destinations, see page 140 "5 Registering a Shared Folder in the Machine's Address Book".

4 Specifying Access Privileges for the Created Shared Folder

If you wish to specify access privileges for the created folder to allow other users or groups to access it on Windows, configure it as follows:

This is not necessary if not you do not wish to specify access privileges.

1. Right-click the folder created in Step 3, and then click [Properties].
2. On the [Security] tab, click [Edit...].
3. Click [Add...].
4. In the [Select Users or Groups] window, click [Advanced...].
5. Specify one or more object types, select a location, and then click [Find Now].
6. From the list of results, select the groups and users you want to grant access to, and then click [OK].
7. In the [Select Users or Groups] window, click [OK].
8. In the [Groups or user names:] list, select a group or user, and then, in the [Allow] column of the permissions list, select either the [Full control] or [Modify] check box.
9. Click [OK] twice.

Next, register scan destinations. For details about registering scan destinations, see page 140 "5 Registering a Shared Folder in the Machine's Address Book".

↓ Note

- If you are creating a shared folder for the first time on this computer, you must enable the file sharing function. For details, see Windows Help.

5 Registering a Shared Folder in the Machine's Address Book

Register scan destinations using Web Image Monitor.

1. Start the web browser and access the machine by entering its IP address.
2. Click [Quick Dial Destination] or [Scan Destination].
3. From the [Destination Type] list, select [Folder].
4. Register information as necessary.

The information you must register are the following items. For details, see page 126 "Registering Scan Destinations".

- Name
 - Service Name
5. Enter the administrator password if required.
 6. Click [Apply].

7. Close the web browser.

Preparations for Scan to Folder are complete.

For details about sending scanned files to the destination you registered to the Address Book, see page 141 "6 Send Scanned Files to a Shared Folder".

↓ Note

- If the machine fails to transfer the file, confirm the following items.
 - Destination is registered to the Address Book correctly.
 - Set the security software or firewall of the destination computer to off and try the job again. For details about security software or the firewall settings, contact your network administrator.
 - If there is more than one destination computer, test the job with other computers. Compare the settings with the computer which succeeded to transfer the file. For details, contact your network administrator.
 - When there is not enough disk space on the destination computer, the machine may fail to transfer the file.

5

6 Send Scanned Files to a Shared Folder

Send scanned files to the shared folder registered in Step 5.

★ Important

- The original in the ADF takes precedence over the original on the exposure glass if you place originals both in the ADF and on the exposure glass.
- Register the scan destination in the Address Book using Web Image Monitor. For details, see page 126 "Registering Scan Destinations".
- When a USB flash memory device is inserted into the machine, scanned documents will be stored in the USB flash memory device. Confirm that there are no USB flash memory devices inserted into the machine.

1. Place the original on the exposure glass or in the ADF.

To place the original, see page 76 "Placing Originals".

2. Press the [Home] key.

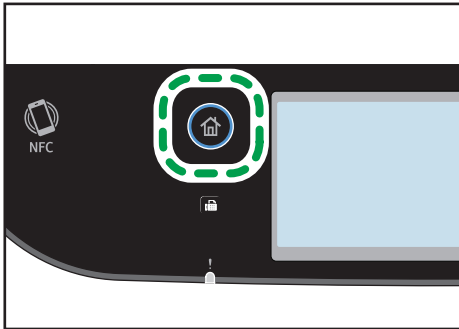

ECC202

3. Press the [Scanner] icon on the [Home] screen.

4. Press the [Folder] tab.

5. Press [Address Book].

6. Select the desired destination, and then press [OK].

7. Press the [B&W Start] key or [Color Start] key.

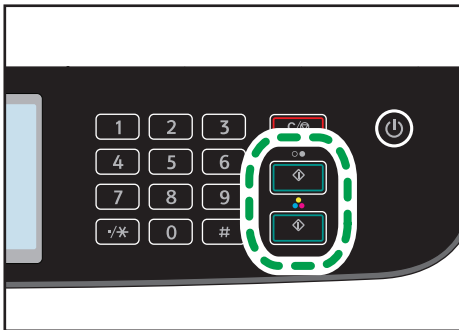

ECC204

To scan in black and white, press the [B&W Start] key.

To scan in color, press the [Color Start] key.

Depending on the machine's settings, you may see the following screen on the display when scanning from the exposure glass.

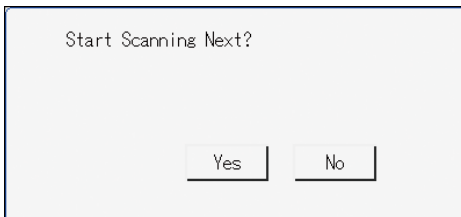

If you see this screen, proceed to the next step.

8. If you have more originals to scan, place the next original on the exposure glass, and then press [Yes]. Repeat this step until all originals are scanned.
9. When all originals have been scanned, press [No] to start sending the scanned file.

Note

- To cancel scanning, press the [Clear/Stop] key. The scan files are discarded.
- You can also specify a destination using [Resend]. For details, see page 151 "Specifying the Scan Destination Using [Resend]".

Basic Operation of Scan to E-mail

This section explains the preparations and procedures to send scanned documents as a file attached to an e-mail.

After following the procedures below, you can send scanned documents to the specified e-mail address.

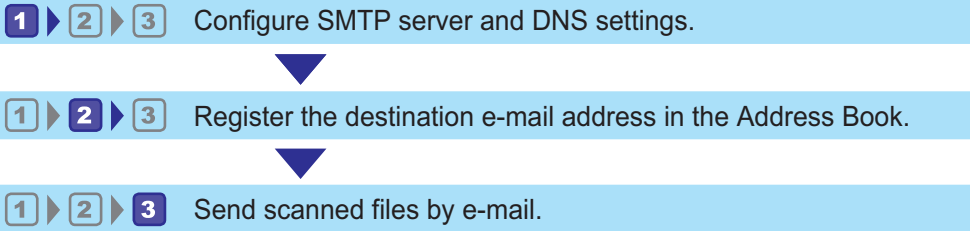

5

1 Configuring SMTP and DNS Settings

To send files via e-mail, SMTP and DNS settings must be configured properly.

For details about SMTP server information, contact the network administrator of your Internet service provider.

Configure SMTP and DNS information using Web Image Monitor.

1. **Start the web browser and access the machine by entering its IP address.**
2. **Click [Network Settings].**
3. **Click the [DNS] tab.**
4. **Register information as necessary.**
For details, see page 293 "Configuring the Network Settings".
Enter the administrator password if required.
5. **Click [OK].**
6. **Click the [SMTP] tab.**
7. **Register information as necessary.**
For details, see page 293 "Configuring the Network Settings".
Enter the administrator password if required.
8. **Click [OK].**
9. **Close the web browser.**

Next, register the destination e-mail address to the Address Book. For details, see page 145 "2 Registering Destination E-mail Addresses to the Address Book".

2 Registering Destination E-mail Addresses to the Address Book

Configure the destination information using Web Image Monitor.

1. Start the web browser and access the machine by entering its IP address.
2. Click [Quick Dial Destination] or [Scan Destination].
3. From the [Destination Type] list, select [E-mail Address].
4. Register information as necessary.

The information you must register are the following items. For details, see page 126 "Registering Scan Destinations".

- Name
- Destination E-mail Address
- Subject

5. Enter the administrator password if required.
6. Click [Apply].
7. Close the web browser.

Preparations for Scan to E-mail are complete.

For details about sending files to the registered destinations, see page 145 "3 Sending Scanned Files by E-mail".

3 Sending Scanned Files by E-mail

This section explains how to send scanned files to the destinations registered in Step 2.

★ Important

- The original in the ADF takes precedence over the original on the exposure glass if you place originals both in the ADF and on the exposure glass.
- Register the scan destination in the Address Book using Web Image Monitor. For details, see page 126 "Registering Scan Destinations".
- When a USB flash memory device is inserted into the machine, scanned documents will be stored in the USB flash memory device. Confirm that there are no USB flash memory devices inserted into the machine.

1. Place the original on the exposure glass or in the ADF.

To place the original, see page 76 "Placing Originals".

2. Press the [Home] key.

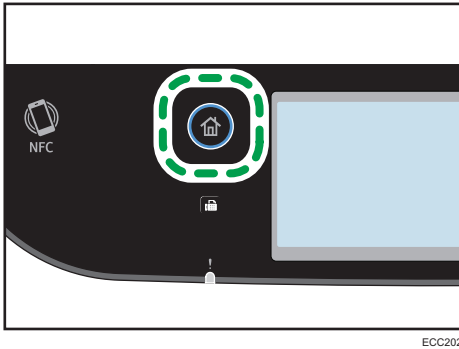

3. Press the [Scanner] icon on the [Home] screen.

4. Press the [Email] tab.

5. Press [Address Book].

6. Select the desired destination, and then press [OK].

When you select a destination, a check mark appears against the selected destination.

7. Press the [B&W Start] key or [Color Start] key.

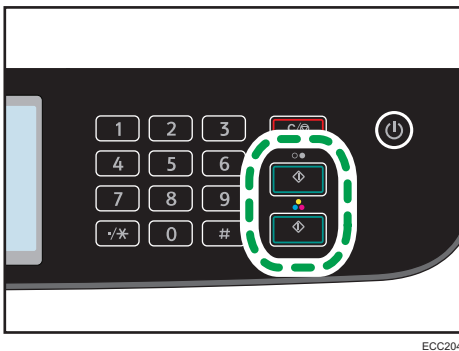

To scan in black and white, press the [B&W Start] key.

To scan in color, press the [Color Start] key.

Depending on the machine's settings, you may see the following screen on the display when scanning from the exposure glass.

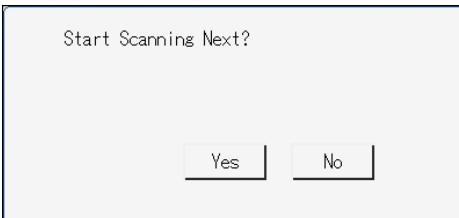

If you see this screen, proceed to the next step.

8. If you have more originals to scan, place the next original on the exposure glass, and then press [Yes]. Repeat this step until all originals are scanned.
9. When all originals have been scanned, press [No] to start sending the scanned file.

Note

- To cancel scanning, press the [Clear/Stop] key. The scan files are discarded.
- You can also specify a destination using [Resend]. For details, see page 151 "Specifying the Scan Destination Using [Resend]".

Basic Operation of Scan to FTP

This section explains the preparations and instructions to send scanned documents to an FTP server. After following the procedures below, you can send scanned documents to an FTP server.

1 ▶ **2** Configure FTP server settings.



1 ▶ **2** Send scanned files to the FTP server.

1 Configuring FTP Server Settings

5

To send files to an FTP server, configure FTP server settings properly. For details about FTP servers, contact your network administrator.

Configure FTP server settings using Web Image Monitor.

1. Start the web browser and access the machine by entering its IP address.
2. Click [Quick Dial Destination] or [Scan Destination].
3. From the [Destination Type] list, select [FTP].
4. Register information as necessary.

The information you must register are the following items. For details, see page 126 "Registering Scan Destinations".

- Name
- Hostname or IP Address

5. Enter the administrator password if required.
6. Click [Apply].
7. Close the web browser.

Preparations for Scan to FTP are complete.

For details about sending files to the registered destinations, see page 148 "**2** Sending Scanned Files to an FTP Server".

2 Sending Scanned Files to an FTP Server

This section explains how to send scanned files to the destinations registered in Step 1.

★ Important

- The original in the ADF takes precedence over the original on the exposure glass if you place originals both in the ADF and on the exposure glass.

- Register the scan destination in the Address Book using Web Image Monitor. For details, see page 126 "Registering Scan Destinations".
- When a USB flash memory device is inserted into the machine, scanned documents will be stored in the USB flash memory device. Confirm that there are no USB flash memory devices inserted into the machine.

1. Place the original on the exposure glass or in the ADF.

To place the original, see page 76 "Placing Originals".

2. Press the [Home] key.

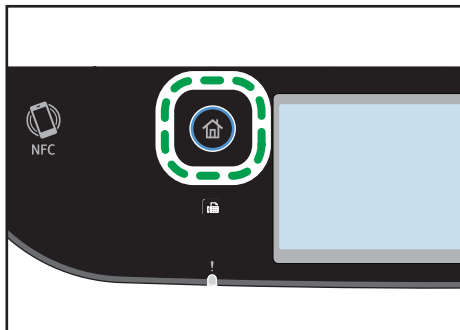

ECC202

3. Press the [Scanner] icon on the [Home] screen.

4. Press the [FTP] tab.

5. Press [Address Book].

6. Select the desired destination, and then press [OK].

When you select a destination, a check mark appears against the selected destination.

7. Press the [B&W Start] key or [Color Start] key.

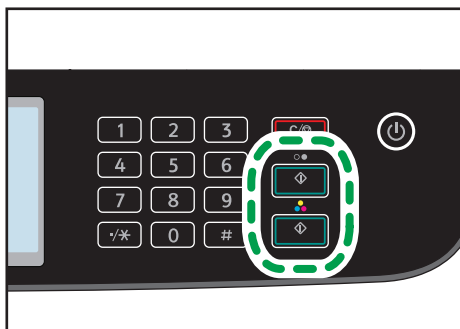

ECC204

To scan in black and white, press the [B&W Start] key.

To scan in color, press the [Color Start] key.

Depending on the machine's settings, you may see the following screen on the display when scanning from the exposure glass.

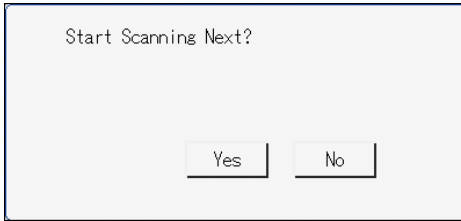

If you see this screen, proceed to the next step.

8. If you have more originals to scan, place the next original on the exposure glass, and then press [Yes]. Repeat this step until all originals are scanned.
9. When all originals have been scanned, press [No] to start sending the scanned file.

↓ Note

- To cancel scanning, press the [Clear/Stop] key. The scan files are discarded.
- You can also specify a destination using [Resend]. For details, see page 151 "Specifying the Scan Destination Using [Resend]".

Specifying the Scan Destination Using [Resend]

This section describes how to specify a destination using [Resend].

Using [Resend]

Press [Resend] to select the last used destination.

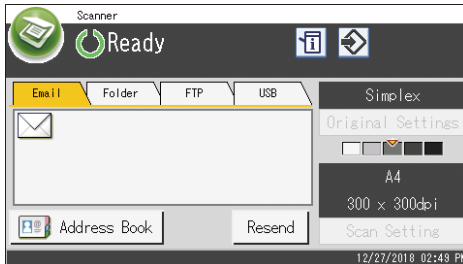

Note

- When you specify a scan destination, the machine's scan settings change automatically according to the information registered for that destination in the Address Book. If necessary, you can change the scan settings using the control panel. For details, see page 167 "Specifying Scan Settings for Scanning".
- [Resend] is not effective for the first scan job after the machine is turned on.
- You can press the [Clear/Stop] key to clear the destination.

Basic Procedures for Saving Scan Files on a USB Flash Memory Device

This section explains basic operations of Scan to USB. Files are saved to the USB flash memory device inserted into the machine.

★ Important

- The original in the ADF takes precedence over the original on the exposure glass if you place originals both in the ADF and on the exposure glass.
- This machine does not support the use of external USB hubs.
- Not all types of USB flash memory devices are supported.
- When using Scan to USB, set [Save Scn Data to USB] to [Active]. For details, see page 251 "Administrator Tools Settings".

5

1. Insert the USB flash memory device into the USB port.

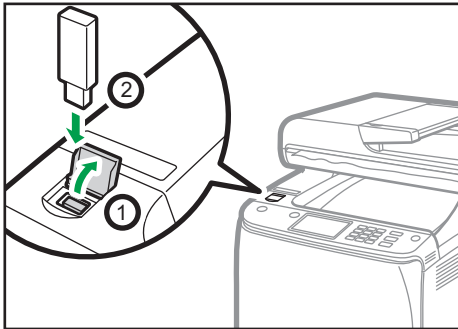

ECC127

2. Press the [Home] key.

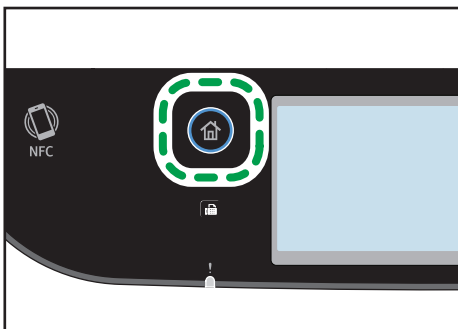

ECC202

3. Press the [Scanner] icon on the [Home] screen.

4. Press the [USB] tab.

5. Place the original on the exposure glass or in the ADF.

To place the original, see page 76 "Placing Originals".

Specify the scanning settings as necessary. For details of specifying the scanning settings, see page 167 "Specifying Scan Settings for Scanning".

6. Press the [B&W Start] key or [Color Start] key.

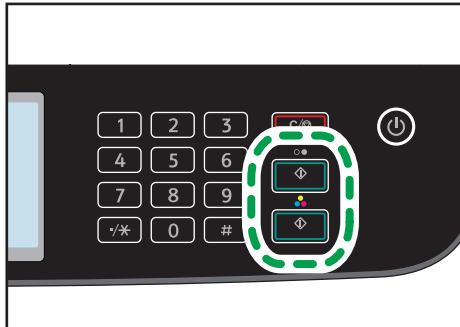

ECC204

To scan in black and white, press the [B&W Start] key.

To scan in color, press the [Color Start] key.

Depending on the machine's setting, you will see the following screen on the display.

- When in halftone black-and-white scanning mode:

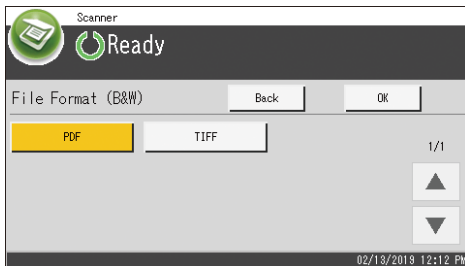

- When in color or gray scale black-and-white scanning mode:

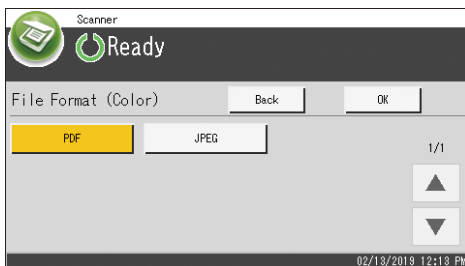

7. Press the appropriate selection key according to the desired file format, and then press [OK].

Depending on the machine's settings, you may see the following screen on the display when scanning from the exposure glass.

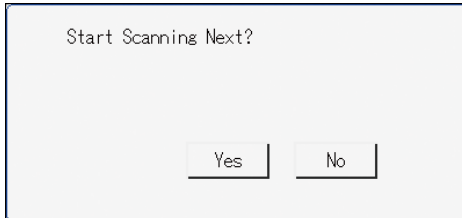

If you see this screen, proceed to the next step.

- 8. If you have more originals to scan, place the next original on the exposure glass, and then press [Yes]. Repeat this step until all originals are scanned.**
- 9. When all originals have been scanned, press [No] to start sending the scanned file.**
- 10. Wait until "Completed the Process" is displayed on the screen.**

Scanned files are saved in the root directory of the USB flash memory device.

11. Remove the USB flash memory device from the machine.

↓ Note

- To cancel scanning, press the [Clear/Stop] key. The scan files are discarded.
- You can configure the machine to perform black-and-white scanning in halftone or grayscale by changing [B&W Scanning Mode] setting under [Scanner Settings]. For details about [B&W Scanning Mode], see page 222 "Scanner Settings".
- If the [Limitless Scan] setting under [Scanner Settings] is enabled, you can place originals on the exposure glass repeatedly in a single scan procedure. For details about [Limitless Scan], see page 222 "Scanner Settings".
- If the [Single/ Multi Page] setting under scanner settings is set to [Multi-page], you can scan multiple pages to create a single PDF or TIFF file containing all pages. However, if the file format is JPEG, a single-page file will be created for every page scanned. For details about [Single/ Multi Page], see page 222 "Scanner Settings".
- If paper is jammed in the ADF, the scan job will be put on hold. To resume the current job, remove the jammed paper and scan the originals again starting from the jammed page. For details about how to remove the paper jammed in the ADF, see page 357 "Removing Scanning Jams".

Basic Operation for RICOH Scan Utility V2



1. Your Computer (RICOH Scan Utility V2 already installed)

Instruct the machine to start scanning the original that is set on the machine.

2. This Machine

The original that is set on the machine is scanned, and its data is sent to a client computer.

5

Preparations for Using RICOH Scan Utility V2

This section describes the preparations needed for scanning from RICOH Scan Utility V2.

To use RICOH Scan Utility V2:

★ Important

- Make sure that the machine connects to the network environment.
- Configure the network settings under [Network Settings].
- Install RICOH Scan Utility V2.

To use the USB port, install the TWAIN driver and WIA driver first, which are on the supplied CD-ROM.

Using RICOH Scan Utility V2 to Scan to a Computer

1. Place originals.
2. On the [Start] menu, click [All Programs].
3. Click [M C250 Series Software Utilities].
4. Click [RICOH Scan Utility V2 for M C250 Series].
RICOH Scan Utility V2 starts.
5. Click [Select Machine], and then select the scanner you want to use.

Select the scanner by specifying the IP address or pressing [Search Network Scanner], and then select from the list displayed.

6. On the [General] tab, specify settings according to the types of originals and scanning, and the orientation of the original.
7. On the [Options] tab, specify the file format and the directory to save the file.
8. Click [Scan].
9. After all originals are scanned, click [Exit].

Settings you can configure in the RICOH Scan Utility V2 dialog box

[General] tab

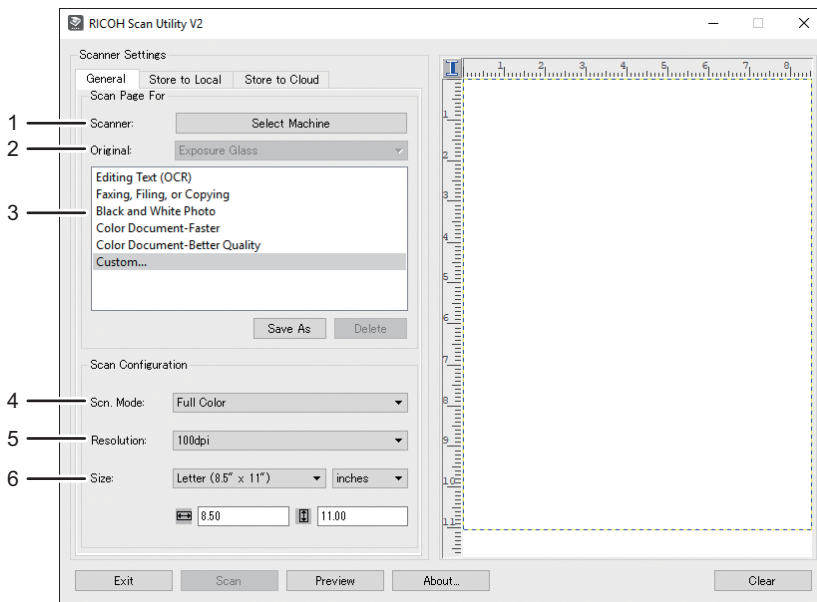

ECC169

1. Scanner:

Select the scanner you want to use.

2. Original:

Select [Exposure Glass] to scan from the exposure glass, or [Automatic Document Feeder] to scan from the ADF.

3. Original type

According to your original, select a setting from the list of options detailed below, or select [Custom...] to configure your own scan settings. [Scn. Mode:], [Resolution:], and [Size:] under [Scan Configuration] will change according to the original type setting you selected here.

- When using the exposure glass:
 - [Editing Text (OCR)]
 - [Faxing, Filing, or Copying]
 - [Black and White Photo]

[Color Document-Faster]
 [Color Document-Better Quality]
 [Custom...]

- When using the ADF:

[ADF-Faster]
 [ADF-Better]
 [ADF-Gray]
 [Custom...]

4. Scn. Mode:

Select from [Full Color], [Grayscale], [Black and White].

5. Resolution:

Select a resolution from the list.

100, 200, 300, 600 dpi

6. Size:

Select the scanning size. If you select [User defined], enter the scanning size directly in the edit box.

Also, you can change the scanning size with your mouse in the preview area. You can select the unit of measure from [cm], [inches], or [pixels].

↓ Note

- [Duplex] appears only when you select [Automatic Document Feeder] in [Original:]. Select the check box when scanning both sides of the original, and then specify the orientation.

[Store to Local] tab

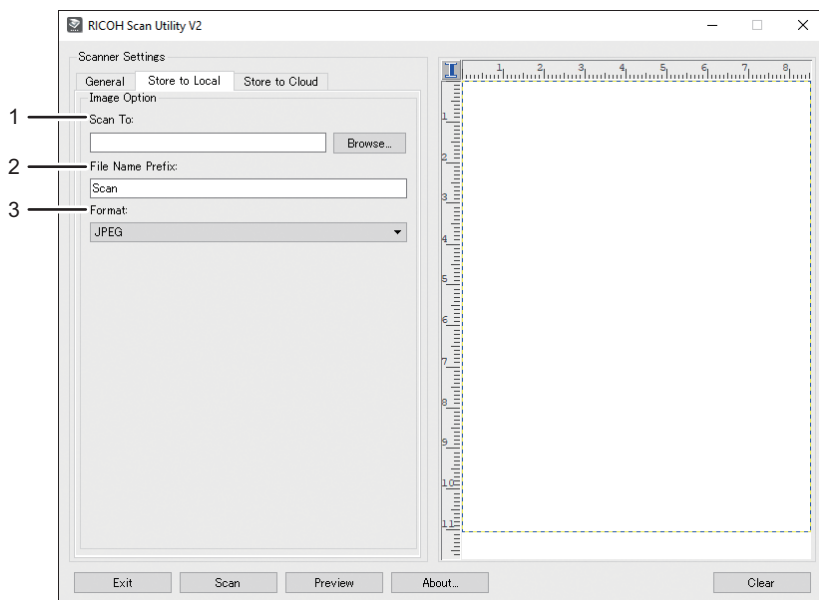

ECC170

1. Scan To:

Specify the directory to save the file.

2. File Name Prefix:

Specify the file name prefix.

3. Format:

Select the file format of the scanned document from JPEG, TIFF, or PDF.

[Store to Cloud] tab

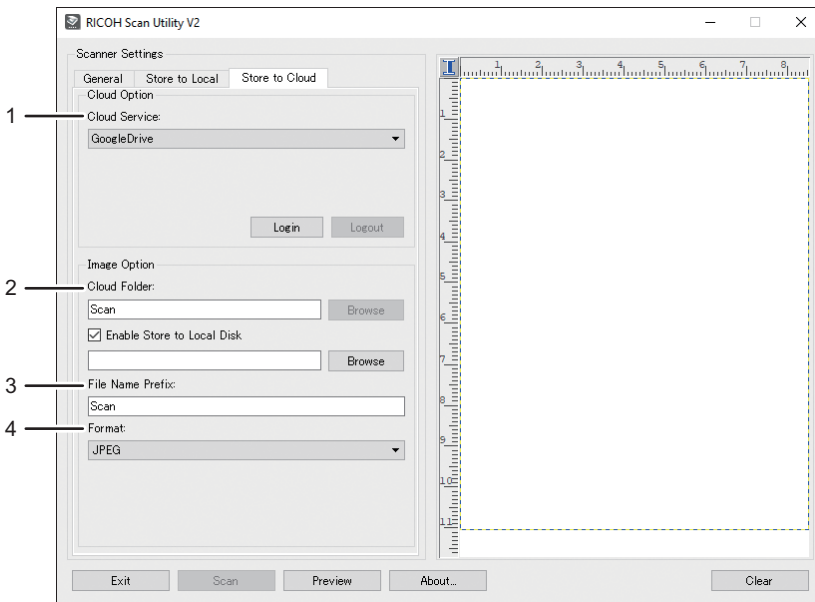

ECC171

1. Cloud Service:

Specify the service to save the file.

2. Cloud Folder:

Specify the directory to save the file.

3. File Name Prefix:

Specify the file name prefix.

4. Format:

Select the file format of the scanned document from JPEG, TIFF, or PDF.

Basic Operation for TWAIN Scanning

This section describes the basic TWAIN scanning operation.

TWAIN scanning is possible if a TWAIN-compatible application is running on your computer.



DUE297

1. Your Computer (TWAIN driver already installed)

Instruct the machine to start scanning the original that is set on the machine.

2. This Machine

The original that is set on the machine is scanned, and its data is sent to a client computer.

5

Using TWAIN scanner

This section describes the preparations for using the TWAIN scanner.

★ Important

- To use the TWAIN scanner, you must install the TWAIN driver, which is on the supplied CD-ROM.
- To use the TWAIN scanner, a TWAIN-compliant application must be installed.

To use the machine as a TWAIN scanner, first do the following:

- Install the TWAIN driver.
- Install a TWAIN-compliant application.

TWAIN scanning

TWAIN scanning is possible if your computer is running a TWAIN-compatible application.

The following is a general scan procedure with the TWAIN driver, so the actual operation may differ depending on the applications you use. For details, see the application's Help.

1. Start a TWAIN-compliant application.
2. Place originals.

3. Open the Scanner Control dialog box.

The Scanner Control dialog box is used to control the scanner using the TWAIN driver. To open the Scanner Control dialog box, select the correct TWAIN scanner using the TWAIN-compliant application. For details, see the application's Help.

4. Make settings according to such factors as the type of original, type of scanning, and orientation of the original.

For details, see the TWAIN driver Help.

5. In the Scanner Control dialog box, click [Scan].

Depending on the security setting, if you press [Scan], a dialog box for entering the user name and password may appear.

If there are more originals to be scanned, place the next original, and then click [Continue].

If there are no more originals to be scanned, click [Complete].

Settings you can configure in the TWAIN dialog box

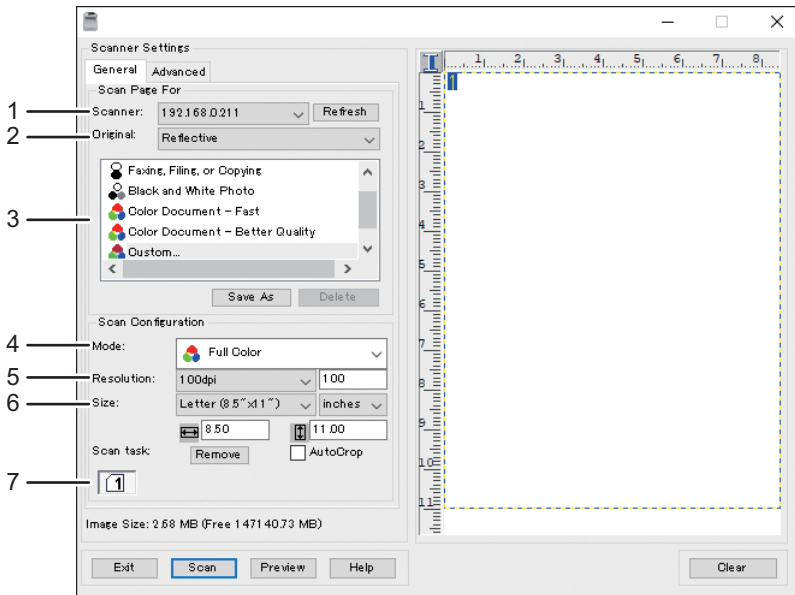

ECC270

1. Scanner:

Select the scanner you want to use. The scanner you select becomes the default scanner. Click [Refresh] to discover all available scanners connected via USB or the network.

2. Original:

Select [Reflective] to scan from the exposure glass, or [Automatic Document Feeder] to scan from the ADF.

3. Original type

According to your original, select a setting from the list of options detailed below, or select [Custom...] to configure your own scan settings. [Mode], [Resolution], and [Size] under [Scan Configuration] will change according to the original type setting you selected here.

- When using the exposure glass:
 - [Editing Text(OCR)]
 - [Faxing, Filing, or Copying]
 - [Black and White Photo]
 - [Color Document-Fast]
 - [Color Document-Better Quality]
 - [Custom...]
- When using the ADF:
 - [ADF-Faster]
 - [ADF-Better]
 - [ADF - Gray]
 - [Custom...]

4. Mode:

Select from color, grayscale, or black-and-white.

5. Resolution:

Select a resolution from the list. If you select [User defined], enter a resolution value directly in the edit box. Note that increasing the resolution also increases the file size and scanning time.

Selectable resolutions vary depending on where the original is set.

- When using the exposure glass:
 - 75, 100, 150, 200, 300, 400, 500, 600, 1200, 2400, 4800, 9600, 19200 dpi, User defined
- When using the ADF:
 - 75, 100, 150, 200, 300, 400, 500, 600 dpi, User defined

6. Size:

Select the scanning size. If you select [User defined], enter the scanning size directly in the edit box. Also, you can change the scanning size with your mouse in the preview area. You can select the unit of measure from [cm], [inches], or [pixels]. Selectable resolutions vary depending on where the original is set. For details, see the TWAIN Help.

7. Scan task: (when using the exposure glass)

Displays up to 10 previously used scan areas. To remove a scan task, select the number of the task, and then click [Remove]. You can select [AutoCrop] to let the scanner automatically detect the size of your original.

Note

- If the scan data is larger than the memory capacity, an error message appears and scanning is canceled. If this happens, specify a lower resolution and scan the original again.

Basic Operation for WIA Scanning

1. Place the original on the exposure glass or in the ADF.
2. On the [Start] menu, click [Control Panel] under [Windows System].
3. Click [View devices and printers].
4. Right-click the icon of the printer model you want to use, and then click [Start scan] to open the dialog box for the scan settings.
5. In the dialog box, configure the scan settings as required, and then click [Scan].
6. Click [Import].

Basic Operation for ICA Scanning

This section describes the basic ICA scanning operation.

You can use the ICA scanner over both USB and network connections.

Installing the ICA Driver

1. Download the driver from the web site.
2. Open the package file.
3. Follow the instructions on the screen.

Using ICA Scanner

This section describes the preparations and procedure for using the ICA scanner.

To use the network connection, configure the network setting.

Install an ICA-compliant application.

ICA Scanning

Setting procedures using macOS 10.13 are shown as an example. The actual procedure may differ depending on the OS X or macOS version you are using.

1. Place the original on the exposure glass or in the ADF.
2. Start System Preferences.
3. Click [Printers & Scanners].
4. Select the scanner you want to use from the list.
5. Select [Open Scanner] in the [Scan] button.

Settings you can configure in the ICA dialog box

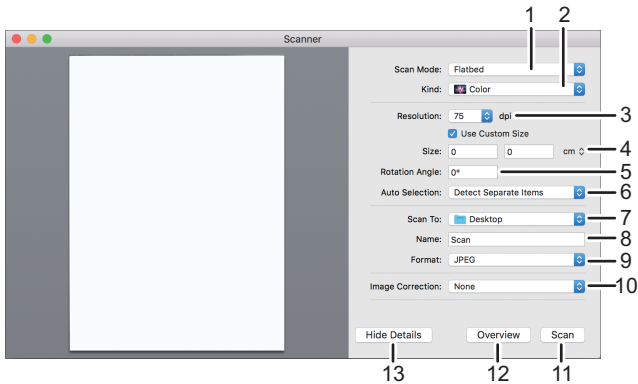

ECC271

5

1. Scan Mode:

Select where the original is placed.

- Flatbed
If the original is placed on the exposure glass, select [Flatbed].
- Document Feeder
If the original is placed in the ADF, select [Document Feeder].

2. Kind:

Set the type of original to [Text], [Black & White], or [Color].

[Text] is suitable for scanning originals containing mainly text.

3. Resolution:

Select a resolution from the list.

Note that increasing the resolution also increases the file size and scanning time.

Selectable resolutions vary depending on where the original is set.

- When using the exposure glass:
75, 100, 150, 200, 300, 400, 500, 600, 1200, 2400, 4800 dpi
- When using the ADF:
75, 100, 150, 200, 300, 400, 500, 600 dpi

4. Size:

Specify the original paper size.

If [Use Custom Size] is selected, you can specify the width and height of the original to be scanned in [Size]. You can specify these dimensions in pixels, inches, or centimeters.

If [Use Custom Size] is not selected, select the original size and orientation.

5. Rotation Angle:

You can specify how many degrees to rotate the scan image clockwise.

6. Auto Selection:

- Detect Separate Items

You can scan multiple originals together and store each scan image as a separate file.

- Detect Enclosing Box

You can scan multiple originals placed on the exposure glass and store their scan images as a single file.

7. Scan to:

Select where to store the scan data.

8. Name:

Name the scan data.

9. Format:

Select the format of the scan data.

- JPEG
- TIFF
- PNG
- JPEG 2000
- GIF
- BMP
- PDF

10. Image Correction:

By selecting [Manual], [Threshold] appears and you can adjust settings such as brightness and contrast.

11. Scan

Click to start scanning.

12. Overview

Click to preview the scan image.

13. Hide Details

Click to hide the settings.

Note

- If the scan data is larger than the memory capacity, an error message appears and scanning is canceled. If this happens, specify a lower resolution and scan the original again.

Using SANE scanning

This driver allows you to scan images and edit them using SANE compatible software.

Specifying Scan Settings for Scanning

When you specify a scan destination, the machine's scan settings change automatically according to the information registered for that destination in the Address Book. If necessary, you can change the scan settings for the current job using the control panel.

Note

- The machine maintains the preset scan settings for the current destination until the machine returns to standby mode.
- Changing the preset scan settings for the current destination does not change the information registered in the Address Book.
- If you specify the last used destination, the preset scan settings become effective again, even if you have changed the settings for the previous job.

Specifying the Scanning Size According to the Size of the Original

5

This section describes how to specify the scanning size according to the size of the current original.

1. Press the [Home] key.

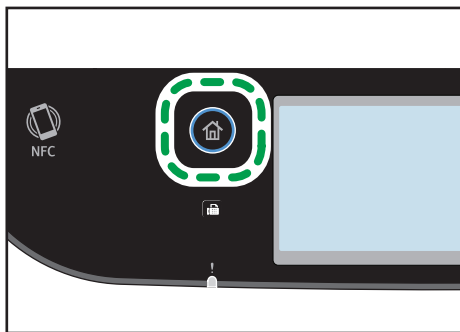

ECC202

2. Press the [Scanner] icon on the [Home] screen.
3. Select the desired destination tab.
4. Press [Address Book].
5. Select the desired destination, and then press [OK].

When you select a destination, a check mark appears against the selected destination.

6. Press [Scan Setting].
7. Press [Scan Size...].
8. Select the size of the original, and then press [OK].

If you selected anything other than [Custom Size], you do not need to perform the remaining steps of the procedure.

9. Select [mm] or [inch].
10. Press [Set Width...].
11. Enter the width, and then press [OK].
12. Press [Set Length...].
13. Enter the length, and then press [OK].
14. Confirm the scan size you entered is displayed, and then press [OK].

↓ Note

- You can change the machine's default [Scan Size] setting to always scan originals with a specific scanning size. For details, see page 222 "Scanner Settings".
- Temporary job settings are cleared in the following cases:
 - When no input is received for the period of time specified in [System Reset Timer] while the initial screen is displayed. For details, see page 251 "Administrator Tools Settings".
 - When the [Clear/Stop] key is pressed while the initial screen is displayed.
 - When the machine's mode is changed.
 - When the power is turned off.
 - When the machine's default for the same setting is changed.

Adjusting Image Density

This section describes how to adjust image density for the current job.

There are five image density levels. The higher the density level, the darker the scanned image.

1. Press the [Home] key.

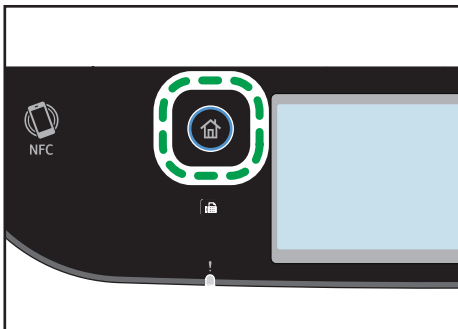

ECC202

2. Press the [Scanner] icon on the [Home] screen.
3. Select the desired destination tab.

When you select a destination, a check mark appears against the selected destination.

4. Press [Address Book].

5. Select the desired destination, and then press [OK].
6. Press [Scan Setting].
7. Press [◀] or [▶] to select the desired density level, and then press [OK].

↓ Note

- You can change the machine's default [Density] setting to always scan with a specific density level. For details, see page 222 "Scanner Settings".
- Temporary job settings are cleared in the following cases:
 - When no input is received for the period of time specified in [System Reset Timer] while the initial screen is displayed. For details, see page 251 "Administrator Tools Settings".
 - When the [Clear/Stop] key is pressed while the initial screen is displayed.
 - When the machine's mode is changed.
 - When the power is turned off.
 - When the machine's default for the same setting is changed.

Specifying Resolution

This section describes how to specify the scan resolution for the current job.

There are six resolution settings. The higher the resolution, the higher the quality but greater the file size.

1. Press the [Home] key.

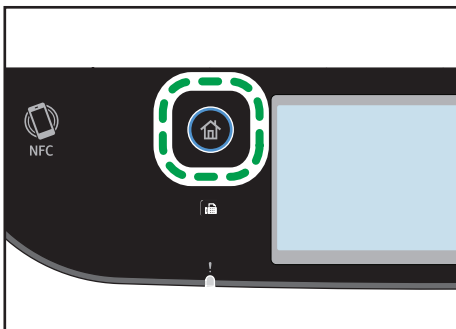

2. Press the [Scanner] icon on the [Home] screen.
3. Select the desired destination tab.
4. Press [Address Book].
5. Select the desired destination, and then press [OK].

When you select a destination, a check mark appears against the selected destination.

6. Press [Scan Setting].
7. Press [Resolution...].

8. Select the desired resolution, and then press [OK].

9. Confirm the resolution you selected is displayed, and then press [OK].

Note

- You can change the machine's default [Resolution] setting to always scan with a specific resolution level. For details, see page 222 "Scanner Settings".
- Temporary job settings are cleared in the following cases:
 - When no input is received for the period of time specified in [System Reset Timer] while the initial screen is displayed. For details, see page 251 "Administrator Tools Settings".
 - When the [Clear/Stop] key is pressed while the initial screen is displayed.
 - When the machine's mode is changed.
 - When the power is turned off.
 - When the machine's default for the same setting is changed.

6. Sending and Receiving a Fax

This chapter describes how to use the fax function and specify the settings.

What You Can Do with the Fax Function

Forward received faxes to receive them wherever you are

By forwarding received faxes to an e-mail address or a folder, you can receive them anytime, anywhere you are.

For details, see page 208 "Forwarding or Storing Faxes in Memory".

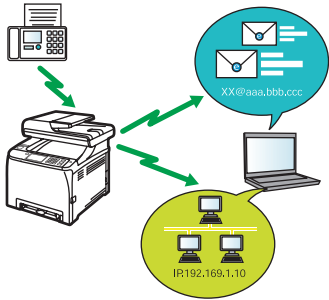

DUE299

Send faxes by data to save paper

By using a LAN-Fax Driver, you can send documents from your computer without printing them.

For details, see page 196 "Using the Fax Function from a Computer (LAN-Fax)".

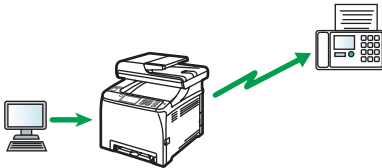

DUE300

Send faxes via the Internet

The machine converts scanned documents to TIFF files and sends them as e-mail attachments to e-mail addresses.

This function is available for M C250FW only.

For details, see page 183 "Internet Fax Transmission".

Fax Setting Workflows

This section explains the preparations and procedures to send fax documents to a folder on a client computer.

After following the procedures below, you can send fax documents from the machine to a shared folder on a client computer.

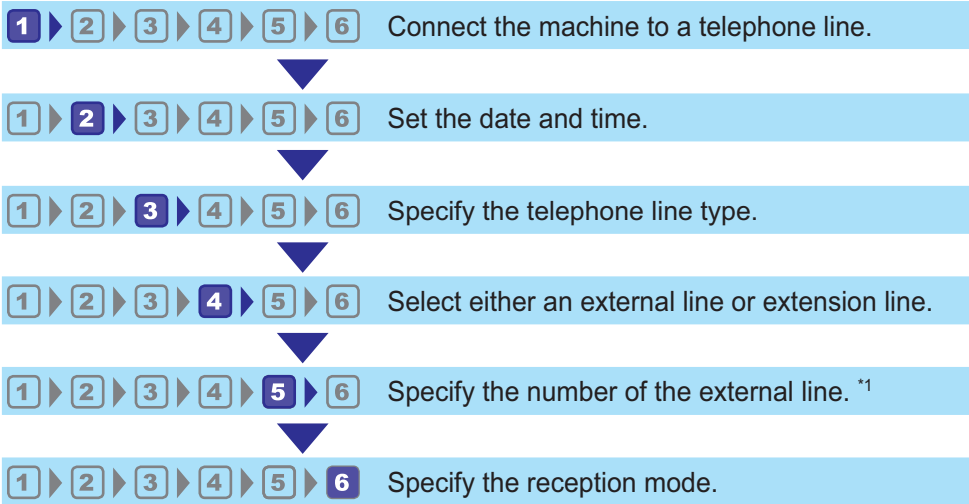

* 1 Specify when using an extension line or a PBX.

Procedure	Reference
1	See Setup Guide.
2	
3	
4	
5	
6	For details about selecting reception modes, see page 202 "Selecting Reception Mode".

Fax Mode Screen

This section provides information about the screen in fax mode.

Screen in standby mode

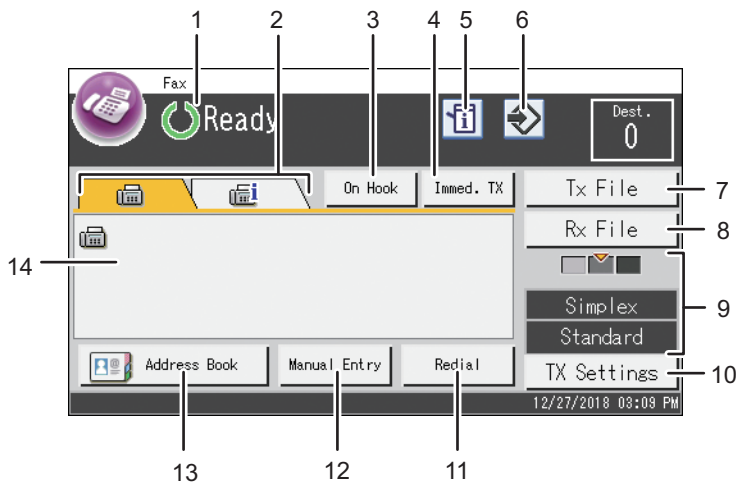

ECC209

1. Current status or messages

Displays the current status or messages.

2. Fax and Internet Fax

Press a tab to switch the transmission type between the [Fax] (📠) screen and [Internet Fax] (🌐) screen.

When the [Fax] (📠) tab is selected, you can specify fax destinations.

When the [Internet Fax] (🌐) tab is selected, you can specify Internet Fax destinations.

3. [On Hook]

Allows you to dial while listening to the tone from the internal speaker. You can send a fax checking the connection.

4. [Immed. TX]

Press to select Immediate Transmission mode. For details, see page 182 "Selecting Transmission Mode".

5. Information icon

Press to check the information.

6. Favorite item icon

Press to register current settings to a favorite item.

7. [Tx File]

Press to display the list of transmission files in memory.

8. [Rx File]

Press to display the list of received files in memory.

9. Current settings

Displays the current duplex, resolution, and density settings.

10. [TX Settings]

Press to specify scan settings.

11. [Redial]

Press to select destinations from recent destinations.

While entering a destination, press this key to insert a pause.

12. [Manual Entry]

Press to specify destinations manually.

13. [Address Book]

Press to select destinations registered in the machine.

14. Entered number

Displays the entered number of a destination.

↓ Note

- The machine's default mode at power on can be specified in the [Function Priority] setting under [Administrator Tools]. For [Function Priority], see page 251 "Administrator Tools Settings".
- The display format for time and date can be specified in [Set Date/Time] under [Administrator Tools]. For setting the date and time, see page 175 "Setting the Date and Time".
- If the Alert indicator flashes on the initial fax display, press the [Home] key, press the [Status] icon, and check the displayed message.

Setting the Date and Time

1. Press the [Home] key.

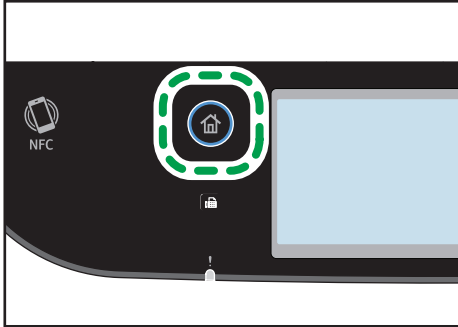

ECC202

2. Press the [Setting] icon on the [Home] screen.
3. Press [Administrator Tools].
4. If you are requested to enter a password, enter the password using the number keys, and then press [OK].
5. Press [Set Date/Time].
6. Press [Set Date].
7. Press the box.
8. Enter the current date, and then press [OK].
9. Confirm the date you entered is displayed, and then press [OK].
10. Press [Set Time].
11. Press the box.
12. Enter the current time, and then press [OK].
13. Confirm the time you entered is displayed, and then press [OK].
14. Press the [Home] key.

↓ Note

- A password for accessing the [Administrator Tools] menu can be specified in [Admin. Tools Lock]. For [Admin. Tools Lock], see page 251 "Administrator Tools Settings".

Registering Fax Destinations

This section describes how to register fax destinations in the Address Book using the control panel. For entering characters, see page 42 "Entering Characters".

The Address Book can also be edited using Web Image Monitor.

★ Important

- The Address Book data could be damaged or lost unexpectedly. The manufacturer shall not be responsible for any damages resulting from such data loss. Be sure to create backup files of the Address Book data periodically. For details about creating backup files, see page 309 "Configuring the Administrator Settings".

The Address Book can contain up to 220 entries (20 Quick Dial entries and 200 Speed Dial entries).

Registering Fax Destinations Using the Control Panel

1. Press the [Home] key.

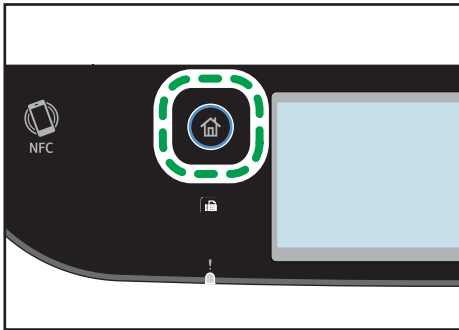

2. Press the [Setting] icon on the [Home] screen.
3. Press [Address Book].
4. If you are requested to enter a password, enter the password using the number keys, and then press [OK].
5. Select [Quick Dial List] or [Speed Dial List].
6. Select the number of Quick Dial List or Speed Dial List you want to register.
7. Press the box next to [Name:].
8. Enter the fax name, and then press [OK].

You can display the software keyboard by double tapping the entry area on the display.

9. Press the box next to [Number:].
10. Enter the fax number, and then press [OK].
11. Confirm the setting, and then press [OK].

12. Press the [Home] key.

↓ Note

- For details about entering characters, see page 42 "Entering Characters".
- A fax number can contain 0 to 9, pause, "*", "#", and space.
- If necessary, insert a pause in the fax number. The machine pauses briefly before it dials the digits following the pause. You can specify the length of the pause time in the [Pause Time] setting under [Transmission Setting]. For [Pause Time], see page 224 "Fax Settings".
- To use tone services on a pulse-dialing line, insert "*" in the fax number. "*" switches the dialing mode from pulse to tone temporarily.
- If the machine is connected to the telephone network through a PBX, make sure to enter the outside line access number specified in [PBX Access Number] before the fax number. For [PBX Access Number], see page 251 "Administrator Tools Settings".
- Use Web Image Monitor to register an Internet Fax destination (an e-mail address). For details about registering an Internet Fax destination, see page 176 "Registering Fax Destinations".
- A password for accessing the [Address Book] menu can be specified in [Admin. Tools Lock]. For [Admin. Tools Lock], see page 251 "Administrator Tools Settings".

Modifying or deleting fax destinations

1. Press the [Home] key.

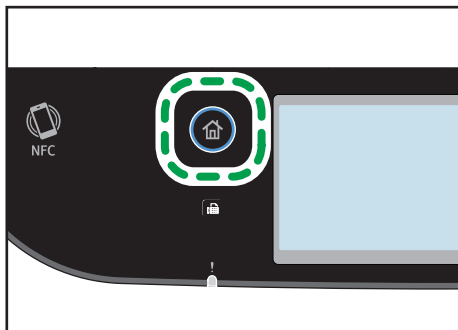

ECC202

2. Press the [Setting] icon on the [Home] screen.
3. Press [Address Book].
4. If you are requested to enter a password, enter the password using the number keys, and then press [OK].
5. Select [Quick Dial List] or [Speed Dial List].
6. Select the number of Quick Dial List or Speed Dial List you want to modify or delete.
7. Press the box next to [Name:].

8. Enter the fax name, and then press [OK].

You can display the software keyboard by double tapping the entry area on the display.

If you want to delete the fax name, press [←] or [C] until the current name is deleted.

9. Press the box next to [Number:].

10. Enter the fax number, and then press [OK].

If you want to delete the fax number, press [←] or [C] until the current number is deleted.

11. Confirm the setting, and then press [OK].

12. Press the [Home] key.

Note

- For details about entering characters, see page 42 "Entering Characters".

Registering Fax Destinations Using Web Image Monitor

1. Start the web browser and access the machine by entering its IP address.
2. Click [Quick Dial Destination] or [Fax Speed Dial Destination].
3. From the [Destination Type] list, select [Fax].
4. Select [Quick Dial Number] or [Speed Dial Number], and then select the registration number from the list.
5. Register information as necessary.
6. Enter the administrator password if required.
7. Click [Apply].
8. Close the web browser.

Fax destination settings

Item	Setting	Description
Quick Dial Number / Speed Dial Number	Required	Select the number to which you want to register Quick Dial or Speed Dial destination.

Item	Setting	Description
Name	Optional	Name of the destination. The name specified here will be shown on the screen when selecting a fax destination. Can contain up to 20 characters.
Fax Number	Required	Fax number of the destination. Can contain up to 40 characters. If the machine is connected to the telephone network through a PBX, make sure to enter the outside line access number specified in [PBX Access Number] before the fax number. For [PBX Access Number], see page 251 "Administrator Tools Settings".
E-mail Address	Optional	E-mail address of the destination of the Internet Fax. Can contain up to 64 characters. This setting appears only for M C250FW.

↓ Note

- A fax number can contain 0 to 9, "P" (pause), "*#", "-", and space.
- If necessary, insert a pause in the fax number. The machine pauses briefly before it dials the digits following the pause. You can specify the length of the pause time in the [Pause Time] setting under [Transmission Setting]. For [Pause Time], see page 224 "Fax Settings".
- For details about using Web Image Monitor, see page 267 "Configuring the Machine Using Utilities".
- To use tone services on a pulse-dialing line, insert "*" in the fax number. "*" switches the dialing mode from pulse to tone temporarily.

Modifying fax destinations

1. Start the web browser and access the machine by entering its IP address.
2. Click [Quick Dial Destination] or [Fax Speed Dial Destination].
If you modify the Speed Dial entry, proceed to Step 4.
3. Click [Fax Quick Dial Destination] tab.
4. Select the entry to modify, and then click [Change].
If you want to delete the entry, click [Delete].
5. Modify settings as necessary.
To delete the entry, confirm the entry you have selected.

6. Enter the administrator password if required.
7. Click [Apply].
8. Close the web browser.

Preventing Transmission to the Wrong Destination

If you want to prevent documents being sent to the wrong destination, you can configure the machine to prompt users twice for the destination, or to display the entered destination prior to transmission.

Re-entering a fax number to confirm destination

Enter the fax number again to confirm the destination is correct.

Transmission is disabled if the confirmation fax number does not match the first fax number. This function helps prevent users accidentally sending faxes to the wrong destination.

★ Important

- This function is available only when an administrator password is specified.

1. Press the [Home] key.

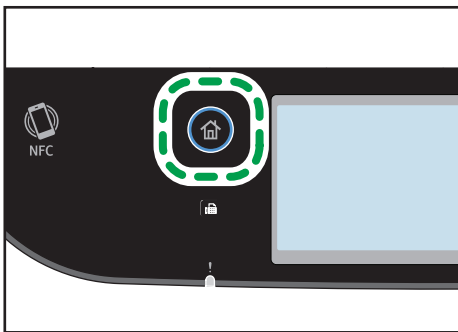

ECC202

2. Press the [Setting] icon on the [Home] screen.
3. Press [Administrator Tools].
4. If you are requested to enter a password, enter the password using the number keys, and then press [OK].
5. Press [▼] twice.
6. Press [Fax No. Confirmation].
7. Select [On] or [Off].
8. Press the [Home] key.

Note

- A password for accessing the [Administrator Tools] menu can be specified in [Admin. Tools Lock]. For [Admin. Tools Lock], see page 251 "Administrator Tools Settings".

Sending a Fax

★ Important

- It is recommended that you call the receiver and confirm with them when sending important documents.

Selecting Transmission Mode

The following explains the transmission modes of the fax function and how to select them.

Types of transmission modes

There are two types of transmission:

- Memory transmission
- Immediate transmission

Selecting the transmission mode

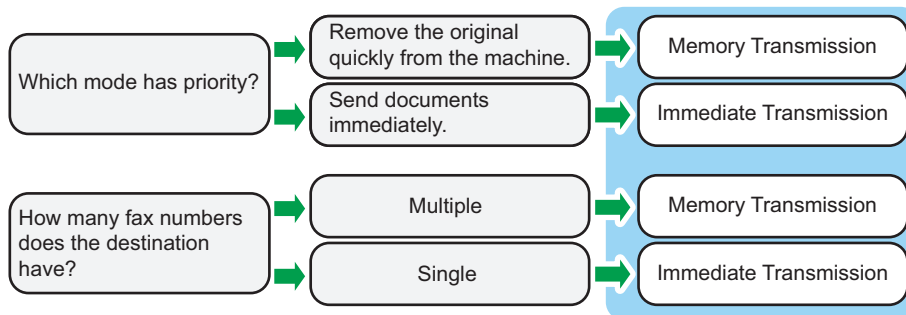

Description of transmission modes

- Memory transmission

In this mode, the machine scans several originals into memory and sends them all at once. This is convenient when you are in a hurry and want to remove the document from the machine. In this mode, you can send a fax to multiple destinations. If the [Auto Redial] under [Transmission Setting] is enabled, the machine redials the fax destination automatically when the line is busy or a transmission error occurs. The number of redial attempts is set to two or three in five-minute intervals, depending on the [Country] setting under [Administrator Tools]. You can disable [Auto Redial] under [Fax Settings]. For details, see page 224 "Fax Settings".

- Immediate transmission

In this mode, the machine scans the original and faxes it simultaneously. This is convenient when you want to send an original quickly or when you want to check the destination you are sending to. The original is not stored in memory. You can only specify one destination. If fax is not received normally, an error message appears on the control panel.

Configuring the transmission mode

1. Press the [Home] key.

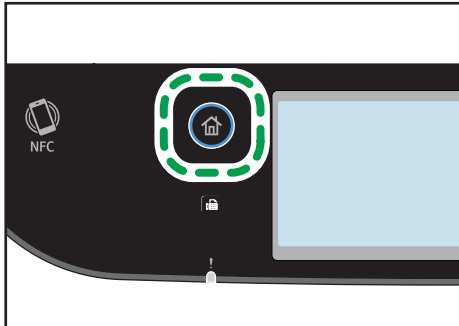

ECC202

2. Press the [Setting] icon on the [Home] screen.
3. Press [Fax Settings].
4. Press [▼].
5. Select [Transmission Setting].
6. Press [Immediate TX].
7. Select [Off], [On], or [Next Fax Only].

For Memory Transmission, select [Off].

For Immediate Transmission, select [On] or [Next Fax Only].

8. Press the [Home] key.

Internet Fax Transmission

You can send faxes over the Internet. When you send faxes to Internet Fax destinations, the machine converts scanned images to TIFF-F format files and send them as attachments to e-mail.

★ Important

- The level of security for Internet communications is low. It is recommended that you use the telephone network for confidential communications.
- Internet Fax delivery might be delayed due to network congestion. Use a telephone line if the fax needs to be delivered in a timely manner.
- This function is available for M C250FW only.

↓ Note

- The Internet Fax function supported by this machine is compliant with ITU-T Recommendation T.37 (Simple Mode).

- To use the Internet Fax function, network settings must be configured properly. For details about network settings, see page 293 "Configuring the Network Settings".
- Internet Fax transmission may take some time before it starts. The machine needs a certain amount of time to convert data in memory prior to transmission.
- Depending on e-mail environment conditions, you may not be able to fax large images.
- The "Photo" resolution is not available for Internet Faxes. Faxes will be sent using "Detail" resolution if "Photo" resolution has been specified.
- If the faxes are received on a computer, a viewer application needs to be installed in order to view the documents.

Basic Operation for Sending a Fax

★ Important

- The original in the ADF takes precedence over the original on the exposure glass if you place originals both in the ADF and on the exposure glass.

1. Press the [Home] key.

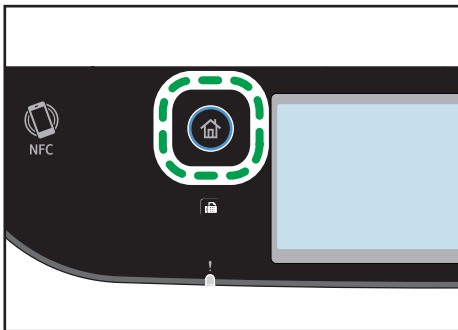

2. Press the [Fax] icon on the [Home] screen.
3. Place the original on the exposure glass or in the ADF.
To place the originals, see page 76 "Placing Originals".
4. Select the [Fax] (📠) tab or [Internet Fax] (📠i) tab.
5. Select [Address Book], [Manual Entry], or [Redial].
6. Enter the fax number (up to 40 characters), or specify a destination.
 - For details about entering characters, see page 42 "Entering Characters".
 - For details about specifying destinations, see page 188 "Specifying the Fax Destination".
 - If the machine is connected to the telephone network through a PBX, make sure to enter the outside line access number specified in [PBX Access Number] before the fax number. For [PBX Access Number], see page 251 "Administrator Tools Settings".

7. Press [OK].

8. Press the [B&W Start] key.

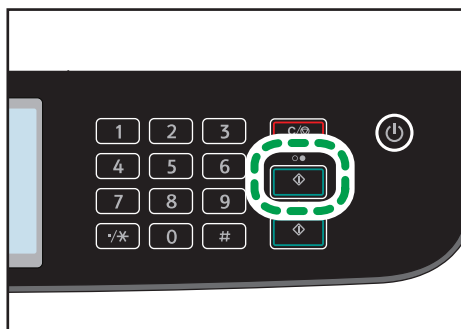

ECC205

- Depending on the machine's settings, you may be prompted to enter the fax number again if you manually entered the destination fax number. In this case, re-enter the number within 60 seconds, and then press the [B&W Start] key. If the fax numbers do not match, go back to Step 6. For [Fax No. Confirmation], see page 251 "Administrator Tools Settings".
- When using the exposure glass in Memory Transmission mode, you will be prompted to place another original. In this case, proceed to the next step.

9. If you have more originals to scan, press [Yes] within 60 seconds, place the next original on the exposure glass, and then press [OK]. Repeat this step until all originals are scanned.

If you do not press [Yes] within 60 seconds, the machine will start to dial the destination.

10. When all originals have been scanned, press [No] or the [B&W Start] key to start sending the fax.

↓ Note

- A fax number can contain 0 to 9, pause, "*", "#", and space.
- If necessary, insert a pause in a fax number. The machine pauses briefly before it dials the digits following the pause. You can specify the length of the pause time in the [Pause Time] setting under [Transmission Setting]. For [Pause Time], see page 224 "Fax Settings".
- To use tone services on a pulse-dialing line, insert "*" in a fax number. "*" switches the dialing mode from pulse to tone temporarily.
- You can specify multiple destinations and broadcast the fax you are sending. For sending a fax using the broadcast function, see page 188 "Specifying the Fax Destination".
- When [Fax No. Confirmation] is set to [On], the machine prompts you to enter the fax number twice only when you dial the destination manually. Destinations specified using the Speed Dial function or [Redial] need not be confirmed. For details about [Fax No. Confirmation], see page 180 "Preventing Transmission to the Wrong Destination".

- When in Memory Transmission mode, you can enable the [Auto Redial] setting under [Transmission Setting] to set the machine to automatically redial the destination if the line is busy or an error occurs during transmission. For [Auto Redial], see page 224 "Fax Settings".
- When in Memory Transmission mode, the machine's memory may become full while scanning the originals. In this case, the screen prompts you to cancel the transmission or to send only the pages that have been scanned successfully.
- You can scan 2-sided originals from the ADF in Memory Transmission mode. Specify how to scan 2-sided originals in the [Fax Original] setting under [Transmission Setting]. For [Fax Original], see page 224 "Fax Settings".
- If paper is jammed in the ADF, the jammed page has not been scanned properly. When the machine is in Immediate Transmission mode, resend the fax starting from the jammed page. When in Memory Transmission mode, scan the entire originals again. For details about removing paper jammed in the ADF, see page 349 "Removing Paper Jams".
- The machine can store up to 5 unsent fax jobs.

Canceling a Transmission

6

This section explains how to cancel a fax transmission.

Canceling a Transmission Before the Original Is Scanned

Use this procedure to cancel a transmission before pressing the [B&W Start] key.

1. Press the [Clear/Stop] key.

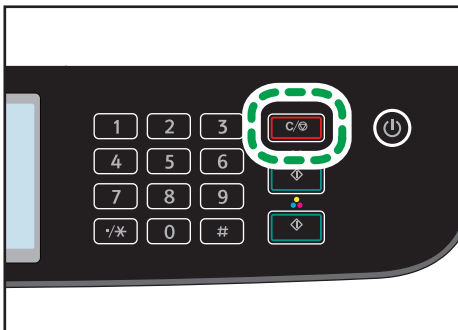

ECC203

Canceling a Transmission While the Original Is Being Scanned

Use this procedure to cancel scanning or transmitting of the original while it is being scanned.

1. Press the [Clear/Stop] key.

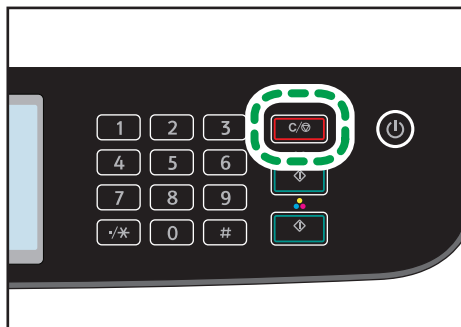

ECC203

2. Press [Fax Jobs] on the [Cancel Jobs] screen.

Canceling a Transmission After the Original Is Scanned (While a Transmission Is in Progress)

Use this procedure to delete a file that is being sent after the original is scanned.

1. Press the [Clear/Stop] key while "Transmitting..." is displayed on the display.

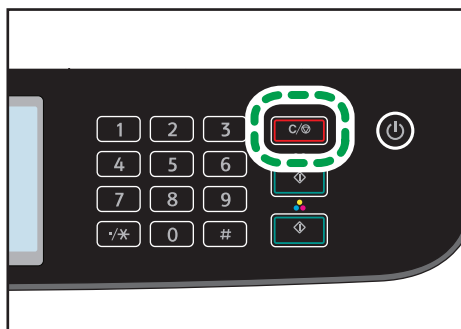

ECC203

2. Press [Fax Jobs] on the [Cancel Jobs] screen.

↓ Note

- If you cancel a document while it is being sent, the transmission is halted as soon as you finish the cancellation procedure. However, some pages of the document may already have been sent and received at the other end.
- If the transmission finishes while this procedure is being processed, the transmission is not canceled. Note that the transmission duration is short if an Internet Fax is being executed.
- If you cancel sending a fax while broadcasting, only the fax to the current destination is canceled. The fax will be sent to the subsequent destinations as normal. For details about sending a fax using the broadcast function, see page 188 "Specifying the Fax Destination".

Canceling a Transmission After the Original Is Scanned (Before a Transmission Starts)

Use this procedure to delete a file stored in memory before its transmission starts.

Use the following procedure to delete a file stored in memory (such as automatic redial) before its transmission starts.

1. Confirm that the initial screen for Fax settings is shown on the display.

For details about the initial screen, see page 173 "Fax Mode Screen".

2. Press [Tx File].

3. Select the file you want to delete.

4. Press [Delete] or [Delete All].

- [Delete]

To delete a fax job, select the desired job, and then select [Yes]. Selecting [No] exits to the previous level of the menu tree without deleting the fax job.

- [Delete All]

To delete the fax jobs, select [Yes]. Selecting [No] exits to the previous level of the menu tree without deleting the fax job.

5. Press [Exit].

Note

- You cannot view files that are in the process of being sent.
- If you specify a broadcast task, all the unsent destinations are canceled.

Specifying the Fax Destination

Other than entering the destination fax number using the number keys, you can specify destinations using the following functions:

- Quick Dial
- Speed Dial
- Broadcast function
- Redial function

Specifying the destination using Quick Dial

1. Press the [Home] key.

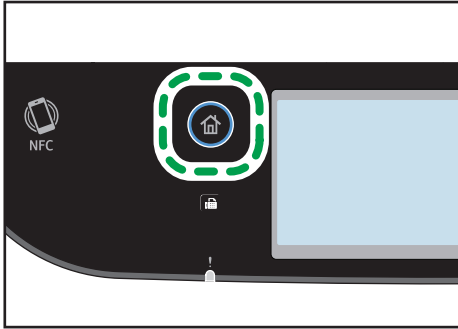

ECC202

2. Press the [Fax] icon on the [Home] screen.
3. Press [Address Book].
4. Press the [Quick Dial] tab.
5. Select the desired Quick Dial entry, and then press [OK].

When you select a Quick Dial, a check mark appears against the selected Quick Dial.

For registering the Quick Dial entries, see page 176 "Registering Fax Destinations".

↓ Note

- You can check the registered names and fax numbers by printing a report. For printing the Quick Dial list, see page 259 "Printing Lists/Reports".

Specifying the destination using Speed Dial

1. Press the [Home] key.

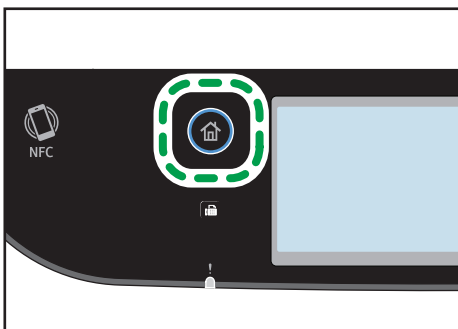

ECC202

2. Press the [Fax] icon on the [Home] screen.
3. Press [Address Book].

4. Press the [Speed Dial] tab.

5. Select the desired Speed Dial entry, and then press [OK].

When you select a Speed Dial, a check mark appears against the selected Speed Dial.

For registering the Speed Dial entries, see page 176 "Registering Fax Destinations".

Note

- You can check the registered names and fax numbers by printing a report. For printing the Speed Dial list, see page 259 "Printing Lists/Reports".

Specifying the destination using the broadcast function

You can send a fax to multiple destinations (up to 100 destinations) simultaneously.

Faxes are sent to destinations in the order they were specified.

1. Press the [Home] key.

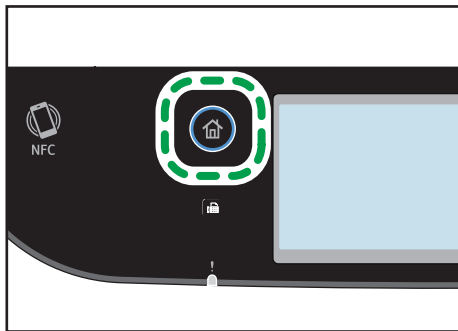

2. Press the [Fax] icon on the [Home] screen.

3. Add a destination by using one of the following methods:

- To add a Quick Dial destination: press [Address Book], press the [Quick Dial List] tab, select a destination, and then press [OK].
- To add a Speed Dial destination: press [Address Book], press the [Speed Dial List] tab, select a destination, and then press [OK].
- To add a manually-specified destination: press [Manual Entry], press the box, enter the destination fax number, and then press [OK] twice.

Note

- While specifying multiple destinations, you can press the [Clear/Stop] key to clear all destinations.
- If you specify multiple destinations in Immediate Transmission mode, the mode switches to Memory Transmission mode temporarily.
- While broadcasting, pressing [Clear] cancels the fax to the current destination only.

- If the destinations contain both normal fax destinations and Internet Fax destinations, the fax will be sent to the Internet Fax destinations first (M C250FW only).

Specifying the destination using the redial function

You can specify the last used destination as the destination for the current job.

This function saves time when you are sending to the same destination repeatedly, as you do not have to enter the destination each time.

1. Press the [Home] key.

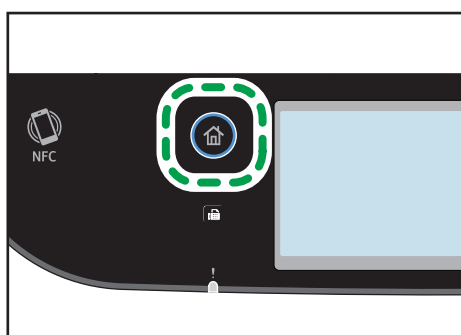

2. Press the [Fax] icon on the [Home] screen.
3. Press [Redial].
4. Specify the destination, and then press [OK].

Useful Sending Functions

You can check the status of the other party's machine easily before sending a fax by using the On Hook Dial function. Using an external telephone, you can talk and send a fax in one call.

★ Important

- This function is not available with Internet Fax.

Sending a fax using On Hook Dial

The On Hook Dial function allows you to check the destination's status while listening to the tone from the internal speaker. This function is useful when you want to ensure that the fax will be received.

★ Important

- The On Hook Dial function cannot be used when [Fax No. Confirmation] under [Administrator Tools] is enabled.

1. Place the original.
2. Press the [Home] key.

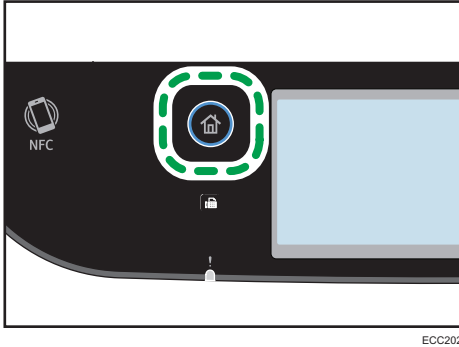

3. Press the [Fax] icon on the [Home] screen.
4. Press [On Hook].
[On Hook] appears on the screen.
5. Specify the destination using the number keys.
6. If you hear a high pitched tone, press the [B&W Start] key.

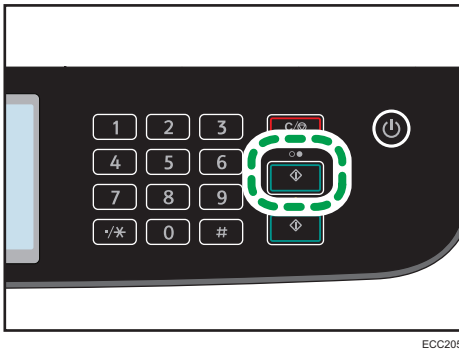

7. If the original is placed on the exposure glass, press [TX], and then press the [B&W Start] key.

Note

- For details about selecting the transmission mode, see page 182 "Selecting Transmission Mode".
- For details about [Fax No. Confirmation], see page 251 "Administrator Tools Settings".

Sending a fax after a conversation

An external telephone allows you to send a fax after finishing your conversation without having to disconnect and redial. This function is useful when you want to ensure that the fax has been received.

1. Place the original.

2. Press the [Home] key.

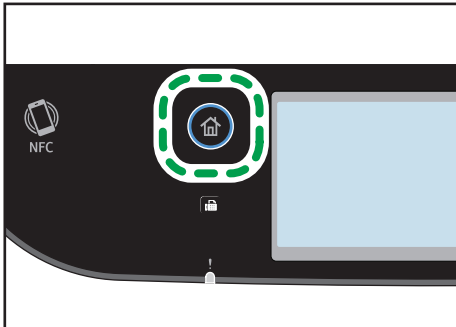

ECC202

3. Press the [Fax] icon on the [Home] screen.
4. Pick up the handset of the external telephone.
5. Specify the destination using the external telephone.
6. When the other party answers, tell the receiver that you want to send them a fax document (ask them to switch to facsimile mode).
7. If you hear a high pitched tone, press the [B&W Start] key.

6

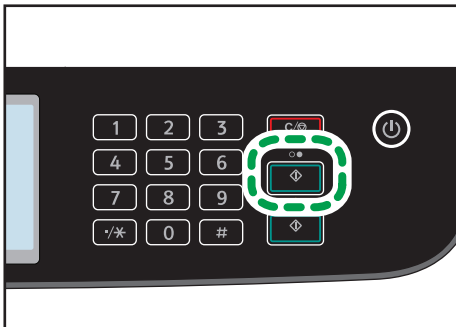

ECC205

8. If the original is placed on the exposure glass, press [TX], and then press the [B&W Start] key.
9. Replace the handset.

Specifying Scan Settings for Faxing

Adjusting image density

This section describes how to adjust image density for the current job.

There are three image density levels. The darker the density level, the darker the printout.

1. Press the [Home] key.

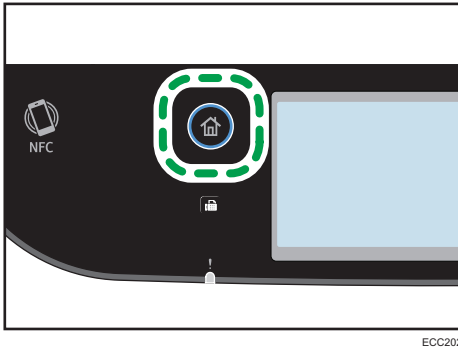

2. Press the [Fax] icon on the [Home] screen.

3. Press [TX Settings].

4. Press [◀] or [▶] to select the desired density level, and then press [OK].

5. Press [OK].

↓ Note

- You can change the machine's default [Density] setting to always scan with a specific density level. For [Density], see page 224 "Fax Settings".

Specifying the resolution

This section describes how to specify the scan resolution for the current job.

There are three resolution settings:

Standard

Select this when the original is a printed or typewritten document with normal-sized characters.

Detail

Select this when the original is a document with small print.

Photo

Select this when the original contains images such as photographs or shaded drawings.

1. Press the [Home] key.

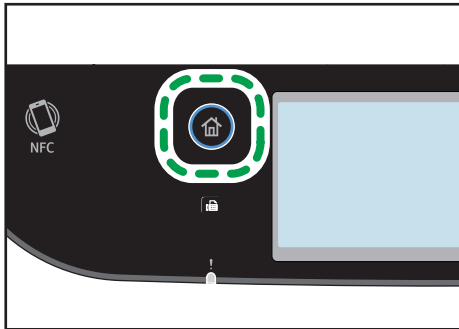

2. Press the [Fax] icon on the [Home] screen.
3. Press [TX Settings].
4. Press [Resolution].
5. Select the desired resolution, and then press [OK].
6. Confirm the resolution you selected is displayed, and then press [OK].

Note

- You can change the machine's default [Resolution] setting to always scan with a specific resolution level. For [Resolution], see page 224 "Fax Settings".

Using the Fax Function from a Computer (LAN-Fax)

This section describes how to use the fax function of the machine from a computer.

You can send a document directly from a computer through this machine to another fax machine, without printing the document.

Basic Operation for Sending Faxes from a Computer

This section describes the basic operation for sending faxes from a computer.

You can select a destination from the LAN-Fax address book or enter a fax number manually. You can send faxes to up to 100 destinations at one time.

The procedure in this section is an example based on Windows 10.

★ Important

- Using LAN-Fax, you can send up to 10 pages (including the cover sheet) at a time.
- Before sending a fax, the machine stores all the fax data in memory. If the machine's memory becomes full while storing this data, the fax transmission will be canceled. If this happens, lower the resolution or reduce the number of pages and try again.

1. Open the file you want to send.
2. On the [File] menu, click [Print...].
3. Select the LAN-Fax driver as the printer, and then click [Print].
4. Specify a destination.
 - To specify a destination from the LAN-Fax address book:
Select a destination from [User List:], and then click [Add to List].
Repeat this step to add more destinations.
 - To enter a fax number directly:
Click the [Specify Destination] tab, and enter a fax number (up to 40 digits) in [Fax Number:], and then click [Add to List].
Repeat this step to add more destinations.
5. To attach a cover sheet, click [Edit Cover Sheet] on the [Specify Destination] tab, and then select the [Attach a Cover Sheet] check box.
Edit the cover sheet as necessary, and then click [OK].
For details about editing a fax cover sheet, see page 201 "Editing a Fax Cover Sheet".
6. Click [Send].

Note

- For details, see the LAN-Fax driver help.
- A fax number can contain 0 to 9, "P" (pause), "*#", "-", and space.
- If necessary, insert a pause in a fax number. The machine pauses briefly before it dials the digits following the pause. You can specify the length of the pause time in the [Pause Time] setting under [Transmission Setting]. For [Pause Time], see page 224 "Fax Settings".
- To use tone services on a pulse-dialing line, insert "*" in a fax number. "*" switches the dialing mode from pulse to tone temporarily.
- To delete an entered destination, select the destination in the [Destination List:], and then click [Delete from List].
- You can register the fax number you entered in the [Specify Destination] tab in the LAN-Fax Address Book. Click [Save to Address Book] to open the dialog box for registering a destination.
- From the [View:] list, you can select the types of destinations to display.
 - [All]: Displays all destinations.
 - [Group]: Displays groups only.
 - [User]: Displays individual destinations only.
- If sending faxes via LAN-Fax is restricted, you must enter a user code in the LAN-Fax driver's property before sending a fax. For details about entering a user code, see page 291 "When Machine Functions are Restricted".

Canceling a fax

You can cancel sending a fax using either the machine's control panel or your computer, depending on the status of the job.

Canceling while the machine is receiving a fax from the computer

If the machine is shared by multiple computers, be careful not to cancel the fax of another user.

1. Double-click the printer icon on the task bar of your computer.
2. Select the print job you want to cancel, click the [Document] menu, and then click [Cancel].
3. Click [Yes].

Canceling while sending a fax

Cancel the fax using the control panel.

1. Press the [Home] key.

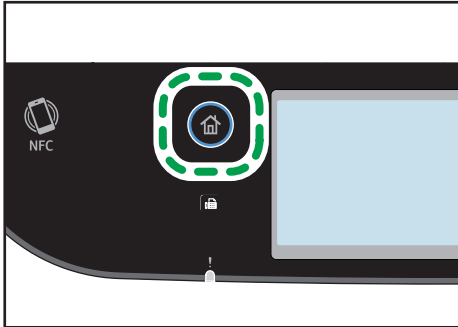

ECC202

2. Press the [Fax] icon on the [Home] screen.
3. Press the [Clear/Stop] key.

Configuring Transmission Settings

6

This section describes how to configure transmission settings in the LAN-Fax driver's properties.

Properties are set separately for each application.

1. On the [File] menu, click [Print...].
2. Select the LAN-Fax driver as the printer, and then click a button such as [Preferences].
LAN-Fax driver properties dialog box appears.
3. Click the [Setup] tab.
4. Configure settings as necessary, and then click [OK].

For details about the settings, see the LAN-Fax driver help.

Configuring the LAN-Fax Address Book

This section describes the LAN-Fax address book. Configure the LAN-Fax address book on the computer. The LAN-Fax address book allows you to specify LAN-Fax destinations quickly and easily.

The LAN-Fax address book can contain up to 1000 entries, including individual destinations and groups of destinations.

Opening the LAN-Fax address book

1. On the [Start] menu, click [Control Panel] under [Windows System].
2. Click [View devices and printers].

3. Right-click the LAN-Fax driver icon, and then click [Printing preferences].
4. Click the [Address Book] tab.

Registering destinations

1. Open the LAN-Fax address book, and then click [Add User].
2. Enter the destination information, and then click [OK].
You must enter a contact name and fax number.
3. Confirm the setting, and then click [OK].

Modifying destinations

1. Open the LAN-Fax address Book, select the destination you want to modify from the [User List:], and then click [Edit].
2. Modify information as necessary, and then click [OK].

Click [Save as new User] if you want to register a new destination with similar information. This is useful when you want to register a series of destinations that contain similar information. To close the dialog box without modifying the original destination, click [Cancel].

3. Confirm the setting, and then click [OK].

Registering groups

1. Open the LAN-Fax address Book, and then click [Add to Group].
2. Enter the group name in [Group Name].
3. Select the destination you want to include in the group from [User List:], and then click [Add].

To delete a destination from a group, select the destination you want to delete from [List of Group Members:], and then click [Delete from List].

4. Click [OK].
5. Confirm the setting, and then click [OK].

Note

- A group must contain at least one destination.
- A group name must be specified for a group. No two groups can have the same group name.
- A single destination can be included in more than one group.

Modifying groups

1. Open the LAN-Fax address Book, select the group you want to modify from the [User List:], and then click [Edit].
2. To add a destination to the group, select the destination you want to add from [User List:] and click [Add].
3. To delete a destination from the group, select the destination you want to delete from [List of Group Members:], and then click [Delete from List].
4. Click [OK].
5. Confirm the setting, and then click [OK].

↓ Note

- A message appears if the name you specified already exists in the LAN-Fax Address Book. Click [OK] and register it under a different name.

Deleting individual destinations or groups

1. Open the LAN-Fax Address Book, select the destination you want to delete from [User List:], and then click [Delete].
A confirmation message appears.
2. Click [Yes].
3. Confirm the setting, and then click [OK].

↓ Note

- A destination is automatically deleted from a group if that destination is deleted from the LAN-Fax Address Book. If you are deleting the last destination from a group, a message asking you to confirm the deletion appears. Click [OK] if you want to delete the group.
- Deleting a group does not delete the destinations it contains from the LAN-Fax Address Book.

Exporting/Importing LAN-Fax Address Book data

★ Important

- The following procedure is based on Windows 10 as an example. If you are using another operating system, the procedure might vary slightly.

Exporting LAN-Fax Address Book data

LAN-Fax Address Book data can be exported to a file in CSV (Comma Separated Values) format. Follow this procedure to export LAN-Fax Address Book data.

1. Open the LAN-Fax Address Book, and then click [Export].

2. **Navigate to the location to save the LAN-Fax Address Book data, specify a name for the file, and then click [Save].**

Importing LAN-Fax Address Book data

LAN-Fax Address Book data can be imported from files in CSV format. You can import address book data from other applications if the data is saved as a CSV file.

1. **Open the LAN-Fax Address Book, and then click [Import].**
2. **Select the file containing the address book data, and then click [Open].**

A dialog box for selecting the items to import appears.

3. **For each field, select an appropriate item from the list.**

Select [*empty*] for fields for which there is no data to import. Note that [*empty*] cannot be selected for [Name] and [Fax].

4. **Click [OK].**

For details about the settings, see the LAN-Fax driver help.

Note

- CSV files are exported using Unicode encoding.
- LAN-Fax Address Book data can be imported from CSV files whose character encoding is Unicode or ASCII.
- Group data cannot be exported or imported.
- Up to 1000 destinations can be registered in the LAN-Fax Address Book. If this limit is exceeded during importing, the remaining destinations will not be imported.

Editing a Fax Cover Sheet

1. **On the [File] menu, click [Print...].**
2. **Select the LAN-Fax driver as the printer, and then click [Print].**
3. **Click the [Specify Destination] tab, and then click [Edit Cover Sheet].**
4. **Configure settings as necessary, and then click [OK].**

For details about the settings, see the LAN-Fax driver help.

Receiving a Fax

★ Important

- When receiving an important fax, we recommend you confirm the contents of the received fax with the sender.
- The machine may not be able to receive faxes when the amount of free memory space is low.

↓ Note

- You can use an external telephone to use this machine as a telephone.
- Only A4, Letter, or Legal size paper can be used for printing faxes.

Selecting Reception Mode

The following explains the reception modes of the fax function and how to select them.

★ Important

- In FAX/TAD mode, the machine receives the fax automatically after the external telephone answering device rings the number of times specified in [No. of Rings (TAD)]. Set the external telephone answering device to ring before receiving a fax. For details about [No. of Rings (TAD)], see page 224 "Fax Settings".

Types of reception mode

There are four types of reception:

- Fax Only mode
- FAX/TEL Manual mode
- FAX/TEL Auto mode
- FAX/TAD mode

Selecting the reception modes

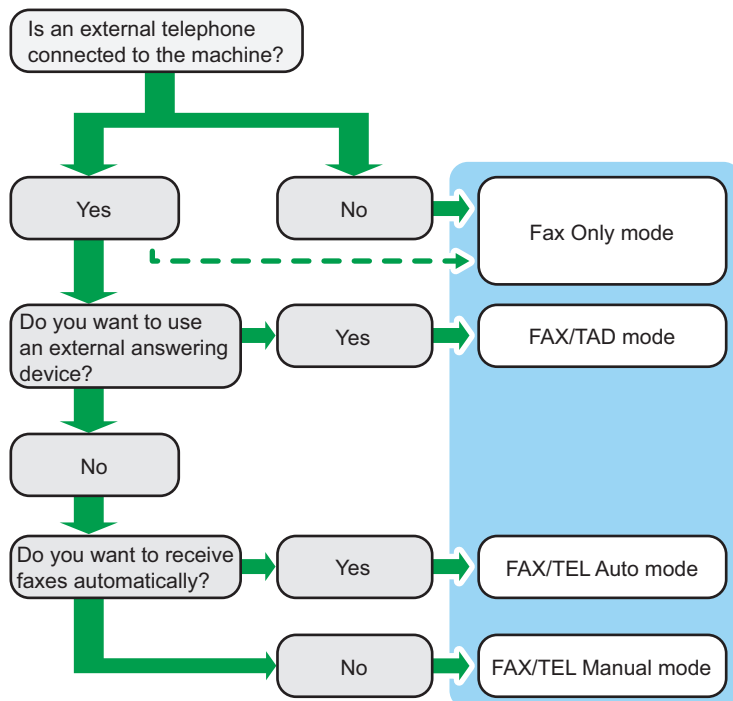

Description of reception modes

- Fax Only mode (auto reception)
 - When an external telephone is not connected
The machine automatically answers all incoming calls in fax reception mode.
 - When an external telephone is connected
The machine automatically answers all incoming calls in fax reception mode after the external telephone rings the number of times specified. It is convenient for those who only use telephones for outgoing calls.
- FAX/TAD mode (auto reception)
In this mode, the external telephone answering device answers and records messages when the machine receives telephone calls. If the incoming call is a fax call, the machine receives the fax automatically. For details, see page 205 "Receiving a fax in FAX/TAD mode".
- FAX/TEL Auto mode (auto reception)
In this mode, the machine receives faxes automatically if a fax calling tone is detected from an incoming call. For details, see page 205 "Receiving a fax in FAX/TEL Auto mode".
- FAX/TEL Manual mode (manual reception)

In this mode, you must answer calls with the handset or an external telephone. If a call is a fax call, you must start the fax reception manually. For details, see page 204 "Receiving a fax in FAX/TEL Manual mode".

Configuring the reception mode

1. Press the [Home] key.

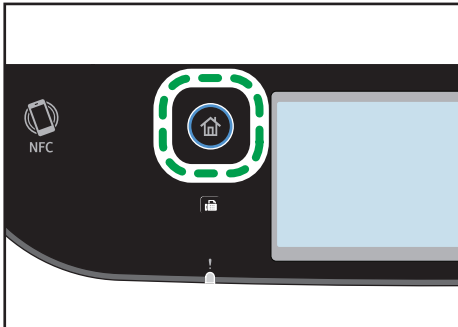

2. Press the [Setting] icon on the [Home] screen.
3. Press [Fax Settings].
4. Press [Reception Settings].
5. Press [Switch Recep. Mode].
6. Select the desired reception mode.
7. Press the [Home] key.

↓ Note

- In FAX/TAD mode, the machine automatically starts to receive faxes after the external telephone answering device rings the number of times specified in [No. of Rings (TAD)] under [Fax Settings]. Make sure to set the external telephone answering device to answer calls before the machine starts to receive faxes. For [No. of Rings (TAD)], see page 224 "Fax Settings".
- An external telephone is required to use this machine as a telephone. For details about connecting an external telephone to the machine, see Setup Guide.

Receiving a fax in FAX/TEL Manual mode

★ Important

- To receive faxes, be sure to first remove any originals loaded in the ADF.

1. Pick up the handset of the external telephone to answer the call.

A normal telephone call starts.

2. When you hear a fax calling tone or no sound, press the [Home] key, press the [Fax] icon, and then press the [B&W Start] key.
3. Press [RX].
4. Press the [B&W Start] key.
5. Replace the handset.

Receiving a fax in Fax Only mode

When the reception mode is set to Fax Only mode, the machine automatically answers all incoming calls in fax reception mode.

↓ Note

- You can specify the number of times the machine rings before answering a call in the [Number of Rings] setting under [Fax Settings]. For [Number of Rings], see page 224 "Fax Settings".
- If you answer a call with the external telephone while the machine is ringing, a normal telephone call starts. If you hear a fax calling tone or no sound, receive the fax manually. To receive the fax manually, see page 204 "Receiving a fax in FAX/TEL Manual mode".

Receiving a fax in FAX/TEL Auto mode

When the reception mode is set to FAX/TEL Auto mode, the machine receives faxes automatically if a fax calling tone is detected from an incoming call.

If you answer a call with the external telephone while the machine is ringing, a normal telephone call starts. If you hear a fax calling tone, receive the fax manually. To receive the fax manually, see page 204 "Receiving a fax in FAX/TEL Manual mode".

↓ Note

- You can specify how long the machine rings before it receives faxes in the [RX Mode Switch Time] setting under [Fax Settings]. For [RX Mode Switch Time], see page 224 "Fax Settings".

Receiving a fax in FAX/TAD mode

When the reception mode is set to FAX/TAD mode, the external telephone answering device answers and records messages when the machine receives telephone calls. If the incoming call is a fax call, the machine receives the fax automatically.

1. When there is an incoming call, the external telephone answering device rings the number of times specified in [No. of Rings (TAD)] under [Fax Settings].

For [No. of Rings (TAD)], see page 224 "Fax Settings".

If the external telephone answering device does not answer, the machine starts to receive the fax automatically.

2. If the external telephone answering device answers, the machine monitors silence on the line for 30 seconds (silence detection).

- If a fax calling tone or no sound is detected, the machine starts to receive the fax automatically.
- If a voice is detected, a normal telephone call starts. The external telephone answering device records messages.

↓ Note

- You can manually receive a fax during silence detection. To receive the fax manually, see page 204 "Receiving a fax in FAX/TEL Manual mode".
- Silence detection does not terminate for 30 seconds even if the external telephone answering device goes on-hook, unless you press the [Clear/Stop] key and disconnect the call.

Receiving an Internet Fax

You can set the machine to periodically check for e-mails (Internet Faxes) and receive them automatically, or you can manually check and receive them.

★ Important

- **Specify the e-mail address of this machine for receiving Internet Faxes in User Account under POP3 settings of Web Image Monitor.**
- **This machine may not be able to receive e-mails in HTML format.**
- **This function is available for M C250FW only.**

Automatic reception

When [Automatic POP] under Internet Fax settings of Web Image Monitor is enabled, the machine periodically connects to the POP3 server, as specified in [POP Interval (minutes)], to check for new e-mails. The machine will download them if there are any.

Manual reception

When [Automatic POP] is disabled, use the control panel to manually connect to the POP3 server and check for new e-mails.

Receiving a fax using the control panel

1. Press the [Home] key.

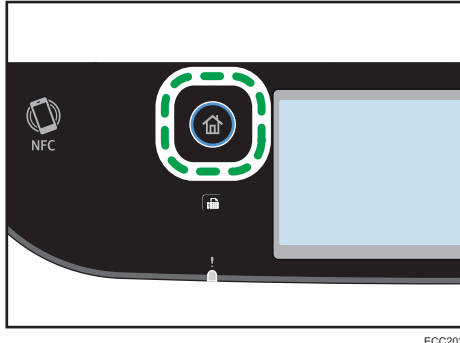

2. Press the [Setting] icon on the [Home] screen.
3. Press [Fax Settings].
4. Press [Reception Settings].
5. Press [▼] twice.
6. Press [Manual POP].
7. In the confirmation screen, press [Yes].

The machine checks for new e-mails and downloads them if there is any.

Receiving a fax using Web Image Monitor

1. Start the Web browser, and access the machine by entering its IP address.
2. Click [Network Settings].
3. Click the [Internet Fax] tab.
4. Select "Automatic POP" to [Active] or [Inactive].
 [Active]: Automatic reception
 [Inactive]: Manual reception
5. Enter the administrator password if required.
6. Click [OK].
7. Close the Web browser.

For details about using Web Image Monitor, see page 268 "Using Web Image Monitor".

ⓘ Note

- If the e-mail reception fails and [Error Notification E-mail] under Internet Fax settings of Web Image Monitor is enabled, an error notification e-mail will be sent to the original sender. For details about settings of Web Image Monitor, see page 299 "Internet Fax Tab".

- If [Error Notification E-mail] is disabled or the error notification e-mail failed, the machine will print out an error report.

Forwarding or Storing Faxes in Memory

To prevent unauthorized users from seeing sensitive faxes, you can set the machine to forward received faxes to a preset destination, or store them in memory without printing them out.

★ Important

- This function is available for M C250FW only.

↓ Note

- The table below shows what happens after forwarding succeeds or fails depending on the machine's configuration.

Forwarding	[Print Forwarded File]	[Print Received File]	Results
Success	Off	Not applicable	The machine deletes the fax from memory.
Success	On	On	The machine prints out the fax and deletes it from memory.
Success	On	Off	The machine stores the fax in memory for later manual printing.
Failure	Off	Not applicable	The machine prints out a forwarding failure report and deletes the fax from memory.
Failure	On	On	The machine prints out a forwarding failure report, prints out the fax, and then deletes it from memory.
Failure	On	Off	The machine prints out a forwarding failure report and stores the fax in memory for later manual printing.

- If the machine is unable to print out a fax due to machine errors such as an empty paper tray or a paper jam, the fax will remain in memory and the Fax Received indicator will flash. The remaining pages will start printing as soon as the problem is resolved.

- The number of forwarding attempts and the attempt interval time can be specified using Web Image Monitor. For details about the forwarding destination, forwarding trials and interval settings, see page 276 "Configuring the System Settings".

Forwarding settings

To specify the forwarding conditions for received faxes, configure the machine as follows:

1. Press the [Home] key.

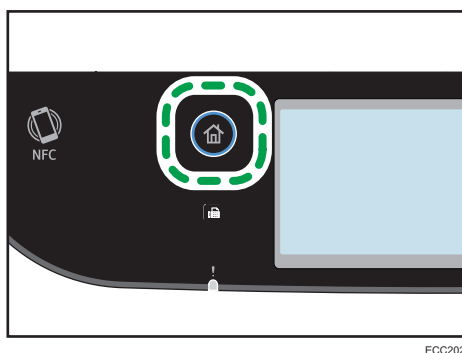

2. Press the [Setting] icon on the [Home] screen.
3. Press [Fax Settings].
4. Press [Reception Settings].
5. Press [▼].
6. Press [Reception File Sett.].
7. Select [Forward].

To send e-mail notifications after faxes are forwarded, proceed to Step 8.

8. Press [▼].
9. Press [Notify Forwarding].
10. Press [Active].
 - [Active]: Send an e-mail notification after forwarding. E-mail notification destination depends on how the forwarding destination is configured.
 - [Inactive]: An e-mail notification is not sent.
11. Press the [Home] key.

Specifying the forwarding destination using Web Image Monitor

1. Start the web browser and access the machine by entering its IP address.
2. Click [System Settings].

3. Click the [Fax] tab.
4. Specify the forwarding destination in [Forwarding Destination].
 - [E-mail Address]: Enter a destination e-mail address.
 - [Scan Destination]: Select a scan destination as a forwarding destination.
5. Enter the administrator password if required.
6. Click [OK].
7. Close the web browser.

For details about using Web Image Monitor, see page 276 "Configuring the System Settings".

Configuring the storing conditions

To specify the storing conditions for received faxes, configure the machine as follows:

1. Press the [Home] key.

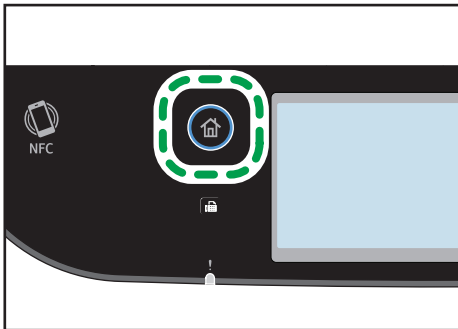

2. Press the [Setting] icon on the [Home] screen.
3. Press [Fax Settings].
4. Press [Reception Settings].
5. Press [▼].
6. Press [Reception File Sett.].
7. Select [Print] or [Forward].
8. Press [Print Received File].
9. Select [On] or [Off].
 - [On]: Automatically print out the received faxes and delete from memory.
 - [Off]: Store the received faxes in memory for later manual printing.

If you select [On], proceed to the next step. If you select [Off], press [OK], and then proceed to Step 11.

10. Enter the start time and the end time, and then press [OK].

The machine prints out the received faxes and delete from memory within the specified time.

11. Press the [Home] key.**Note**

- When the fax is successfully printed out, it will be deleted from memory.
- If the machine is unable to print out a fax due to machine errors such as an empty paper tray or a paper jam, the fax will remain in memory. The remaining pages will start printing as soon as the problem is resolved.

Printing Out Faxes Stored in Memory

This section explains how to print out received faxes stored in the machine's memory.

If the Data-In indicator is flashing, there is a fax in machine's memory. Follow the procedure below to print the fax.

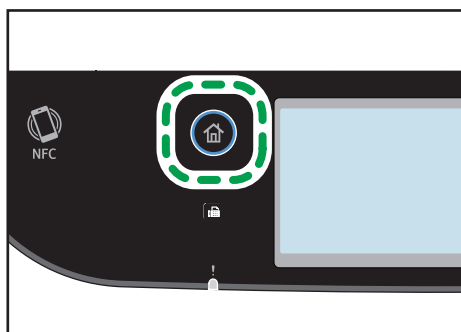
1. Press the [Home] key.

ECC202

2. Press the [Fax] icon on the [Home] screen.**3. Press [RX File].****4. Select the file, and then press [Print].****5. Press [Yes].**

The machine prints out the stored fax and deletes it from memory.

6. Press the [Home] key.**Note**

- Selecting [On] here will enable [Print Received File] under fax feature settings. If you do not want to print out subsequent faxes automatically, set it back to [Off]. For details, see page 224 "Fax Settings".
- If tray 2 is installed, you can select which tray to feed paper from in [Select Paper Tray] under fax feature settings. If you set the machine to switch between Tray 1 and 2 automatically in this setting,

you can also specify the tray the machine uses first in [Paper Tray Priority] under [Paper Settings]. For details about [Select Paper Tray], see page 224 "Fax Settings" and [Paper Tray Priority], see page 246 "Paper Settings".

- If the Fax Received indicator is flashing, there is a received fax in the machine's memory that could not be printed out due to machine errors such as an empty paper tray or a paper jam. The printing will start as soon as the problem is resolved.

Receiving or Rejecting Faxes from Special Senders

You can set the machine to receive (or reject) faxes only from the registered Special Senders. This helps you screen out unwanted documents, such as junk faxes, and prevents the wasting of fax paper.

To use this function, you must first register Special Senders using Web Image Monitor, and then select whether to accept or reject faxes from them.

★ Important

- This function is not available with Internet Fax.

Registering the Special Senders

This section explains how to register Special Senders.

Up to 30 Special Senders can be registered.

1. Start the Web browser, and access the machine by entering its IP address.
2. Click [Special Sender].

The screenshot shows a web interface titled "Special Sender List". At the top, there is a "Program New Destination" section with a "Destination Type" dropdown menu set to "Special Sender". Below this is the "Special Sender List" section, which includes a "Change" button with a plus sign and a "Delete" button. A table with two columns, "No." and "Special Sender Number", is displayed. The table contains five rows, each with a radio button in the "No." column and an empty input field in the "Special Sender Number" column. The numbers 01, 02, 03, 04, and 05 are listed in the "No." column.

No.	Special Sender Number
<input type="radio"/> 01	
<input type="radio"/> 02	
<input type="radio"/> 03	
<input type="radio"/> 04	
<input type="radio"/> 05	

3. From the [Destination Type] list, select [Special Sender].

Program Special Sender

■ Special Sender No. : ▾

■ Special Sender Number :

Please enter Administrator Password.

- 4. Select the Special Sender number from the list (1 to 30).**
- 5. Enter the Special Sender's fax number (up to 20 characters).**
- 6. Enter the administrator password if required.**
- 7. Click [OK].**
- 8. Close the Web browser.**

Note

- A fax number can contain 0 to 9, +, and space.

Limiting the incoming faxes

This section explains how to set the machine to receive (or reject) faxes only from the programmed Special Senders.

- 1. Start the Web browser, and access the machine by entering its IP address.**
- 2. Click [System Settings].**
- 3. Click the [Fax] tab.**
- 4. For [Authorized Reception], click [Active].**
- 5. For [Receive Conditions], click [Special Sender] or [Other Than Special Sender].**
 - **Special Sender**
Select this to receive faxes from the Special Senders and reject faxes from all other senders.
 - **Other Than Special Sender**
Select this to reject faxes from the Special Senders and receive faxes from all other senders.
- 6. Enter the administrator password if required.**
- 7. Click [OK].**
- 8. Close the Web browser.**

Lists/Reports Related to Fax

The lists and reports related to the fax function are as follow:

- Configuration Page
Prints general information and the current configurations of the machine.
- Fax Journal
Prints a fax transmission and reception journal for the last 50 jobs.
- TX/RX Standby Files
Prints a list of fax jobs remaining in the machine's memory to be printed, sent, or forwarded.
- Quick Dial Dest.
Prints a list of scan and fax Quick Dial entries.
- Fax Speed Dial Dest.
Prints a list of Speed Dial entries.
 - By Speed Dial No.
Prints the list with the entries sorted by Speed Dial registration number.
 - By Name
Prints the list with the entries sorted by name.
- Special Sender List
Prints a list of fax Special Senders.
- Power Failure Report
Prints a report when the machine's power has been interrupted while sending or receiving a fax, or images stored in the machine's memory have been lost due to the machine being turned off for a prolonged period of time.

Note

- For more information on Fax Journal and Print TX Status, see page 224 "Fax Settings".
- Repots will be printed on A4 or Letter size paper. Load one of these sizes of paper into the tray before printing reports. For details about loading paper, see page 48 "Loading Paper".

7. Configuring the Machine Using the Control Panel

This chapter describes how to configure the machine using the control panel.

Basic Operation

Use the following procedure to access the machine settings.

To check which category the function you want to configure belongs to, see page 216 "Menu Chart".

1. Press the [Home] key.

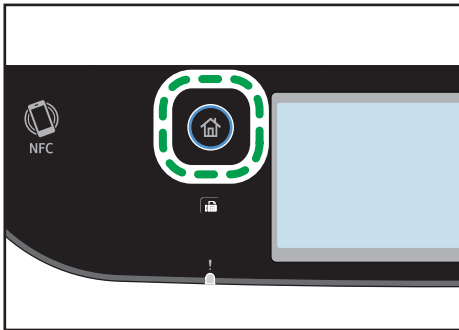

ECC202

2. Press the [Setting] icon on the [Home] screen.
3. Select the settings you want to use.

For a list of available items, see page 216 "Menu Chart".

If you select [Address Book], [Network Settings], or [Administrator Tools] menu, you might be requested to enter a password. Enter the four-digit password, and then press [OK]. For details about the password, see [Admin. Tools Lock] on page 251 "Administrator Tools Settings".

4. To confirm setting items and values displayed, press [OK].
5. To go back to the previous item, press [Back] or [Exit].

Menu Chart

This section lists the parameters included in each menu.

For details about configuring the machine using Web Image Monitor, see page 267 "Configuring the Machine Using Utilities".

Important

- Some items might not appear depending on the model type or machine's configuration.
- Some items can also be configured using Web Image Monitor.

Copier Settings

For details, see page 217 "Copier Settings".

Scanner Settings

For details, see page 222 "Scanner Settings".

Fax Settings

For details, see page 224 "Fax Settings".

Address Book

For details, see page 233 "Address Book".

System Settings

For details, see page 234 "System Settings".

Paper Settings

For details, see page 246 "Paper Settings".

Network Settings

For details, see page 261 "Network Settings".

Print List/Report

For details, see page 259 "Printing Lists/Reports".

Administrator Tools

For details, see page 251 "Administrator Tools Settings".

Printer Settings

For details, see page 242 "Printer Settings".



@Remote

For details, see page 266 "@Remote".

Copier Settings

Item	Description	Value
Select Paper	<p>Specifies the paper size used for printing copies.</p> <p>When a tray is selected, the machine prints from that tray only.</p> <p>When a paper size is selected, the machine prints from the trays that contain the paper of the specified size, except the bypass tray. If Tray 1 and tray 2 both contain the paper of the specified size, the machine starts to print from the tray specified as the priority tray in [Paper Tray Priority] under [Paper Settings]. If that tray runs out of paper, the machine automatically switches to the other tray to continue printing.</p> <p>If Tray 2 is not installed, only [Tray 1] and [Bypass Tray] appear.</p>	<ul style="list-style-type: none"> • Tray 1 • Tray 2 • Bypass Tray • A4 • 8 1/2 × 11 <p>Default: [Tray 1]</p>
Sort	<p>Configures the machine to sort the output pages into sets when making multiple copies of a multi-page document (P1, P2, P1, P2...).</p>	<ul style="list-style-type: none"> • Off • On <p>Default: [Off]</p>



Item	Description	Value
Original Type	Specifies the content of originals, to optimize copy quality.	<ul style="list-style-type: none"> • Text/Photo Select this when the original contains both text and photographs or pictures. • Text Select this when the original contains only text and no photographs or pictures. • Photo Select this when the original contains photographs or pictures. Use this mode for the following types of original: <ul style="list-style-type: none"> • Photographs • Pages that are entirely or mainly photographs or pictures, such as magazine pages. Default: [Text/Photo]
Density	Specifies the image density for photocopying.	Increase the level (black squares) to increase the density. Default: The default setting is the middle of 5 adjustment levels.

Item	Description	Value
Reduce/Enlarge	Specifies the percentage by which copies are enlarged or reduced.	<p> Region A</p> <ul style="list-style-type: none"> • 50% (A4->A6) • 71% (A4->A5 B5->B6) • 82%(8x13->A4) • 93% • 100% • 122%(A5->B5J) • 141% (A5->A4 B6->B5) • 200% (A6->A4) • 400% • Manual Entry <p> Region B</p> <ul style="list-style-type: none"> • 50% • 65% • 78% • 93% • 100% • 129% • 155% • 200% • 400% • Manual Entry <p>Default: [100%]</p>
Color Adjustment	<p>Specify the color balance of red, green and blue.</p> <p>Increase the level (black squares) to increase the color brightness.</p>	<p>Default: The default setting is the middle of 5 adjustment levels.</p>

Item	Description	Value
Duplex/Combine	<p>Specifies combined copying. Select a copy mode according to your original and how you want the copy outputs to appear. For more details, see page 107 "Copying Single-Sided Originals with 2-Sided and Combined Printing" and page 112 "Copying 2-Sided Originals with 2-Sided and Combined Printing".</p> <p>Note that enabling combined copying automatically disables ID card copying.</p>	<ul style="list-style-type: none"> • Off • 1S 2Org->Cmb 2on1 1S • 1S 4Org->Cmb 4on1 1S • 1S Orig->2S Copy • 1S 4Org->Cmb 2on1 2S • 1S 8Org->Cmb 4on1 2S • 2S Orig->1S Copy • 2S 1Org->Cmb 2on1 1S • 2S 2Org->Cmb 4on1 1S • 2S Orig->2S Copy • 2S 2Org->Cmb 2on1 2S • 2S 4Org->Cmb 4on1 2S • Manual 2Sd Scan Mode <p>Default: [Off]</p>
B&W Quality Setting	<p>Specify an image quality for black-and-white printing. The scanning speed using [Fine] is slower than that using [Speed].</p>	<ul style="list-style-type: none"> • Speed • Fine <p>Default: [Speed]</p>

Item	Description	Value
ID Card Setting	Specifies the ID Card Copy setting.	<ul style="list-style-type: none"> • Card Size You can change the ID card copy scanning size. <ul style="list-style-type: none"> • Horizontal: 50 to 216mm (1.90 to 8.50 inches) • Vertical: 50 to 148mm (1.90 to 5.83 inches) <p>Default(horizontal × vertical): 96×64mm (3.78×2.52inches)</p> <ul style="list-style-type: none"> • Center Line Specify whether to draw a center line when making ID card copy. <ul style="list-style-type: none"> • Print • Do not Print <p>Default: [Do not Print]</p>

Scanner Settings

Item	Description	Value
Scan Size	Specifies the scanning size according to the size of the original.	<p>8 1/2 × 14, 8 1/2 × 11, 5 1/2 × 8 1/2, 7 1/4 × 10 1/2, A4, B5JIS, A5, Custom Size</p> <p> Region A</p> <p>Default: [A4]</p> <p> Region B</p> <p>Default: [8 1/2 × 11]</p>
B&W scanning mode	Specifies the scanning mode for black-and-white scanning using the control panel.	<ul style="list-style-type: none"> • Halftone The machine creates 1-bit black-and-white images. Images contain only black and white colors. • Gray Scale The machine creates 8-bit black-and-white images. Images contain black and white, and intermediate gray colors. <p>Default: [Halftone]</p>
Maximum Email Size	Specifies the maximum size of a file that can be sent by e-mail.	<ul style="list-style-type: none"> • 1 MB • 2 MB • 3 MB • 4 MB • 5 MB • No Limit <p>Default: [1 MB]</p>
Density	Specifies the image density for scanning originals.	<p>Increase the level (black squares) to increase the density.</p> <p>Default: The default setting is the middle of 5 adjustment levels.</p>

Item	Description	Value
Resolution	Specifies the resolution for scanning the original.	<ul style="list-style-type: none"> • 100 × 100dpi • 150 × 150dpi • 200 × 200dpi • 300 × 300dpi • 400 × 400dpi • 600 × 600dpi Default: [300 × 300dpi]
Compression (Color)	Specifies the color compression ratio for JPEG files. The lower the compression ratio, the higher the quality but greater the file size.	<ul style="list-style-type: none"> • Low • Medium • High Default: [Medium]
Limitless Scan	Sets the machine to request next originals when scanning with the exposure glass.	<ul style="list-style-type: none"> • Off • On Default: [Off]
Single/ Multi Page	<p>Specifies whether to create a multi-page file containing all pages or separate single-page files when scanning multiple pages.</p> <p>Note that a scanned file can contain multiple pages only when the file format is PDF or TIFF. If the file format is JPEG, a single-page file is created for each scanned page.</p>	<ul style="list-style-type: none"> • Multi-page • Single Page Default: [Multi-page]
Scan Original	Specifies the orientation to scan and whether to have scanned in double side.	<ul style="list-style-type: none"> • Simplex Portrait • Dup.Portrait: T to T • Dup.Portrait: T to B • Dup.Landscape: T to T • Dup.Landscape:T To B Default: [Simplex Portrait]

Fax Settings

Reception Settings

Specifies the settings for receiving a fax.

Item	Description	Value
Switch Recep. Mode	Specifies the reception mode.	<ul style="list-style-type: none"> <li data-bbox="842 511 968 540">• Fax Only The machine automatically answers all incoming calls in fax reception mode. <li data-bbox="842 674 1078 703">• FAX/TEL(Manually) The machine rings when it receives incoming calls. The machine receives faxes only when you manually receive faxes. <li data-bbox="842 913 975 942">• FAX/TAD The machine receives faxes automatically when a fax call is received. Otherwise, the connected telephone answering device answers the call. <li data-bbox="842 1152 1027 1181">• FAX/TEL(Auto) The machine receives faxes automatically if a fax calling tone is detected from an incoming call. If you answer the call with the external telephone while the machine is ringing, a normal telephone call starts. If you hear a fax calling tone, receive the fax manually. <p data-bbox="819 1575 1016 1605">Default: [Fax Only]</p>

Item	Description	Value
Auto Reduction	<p>Sets the machine to reduce the size of a received fax if it is too large to print on a single sheet of paper.</p> <p>Note that the machine only reduces the size down to 74%. If further reduction is required to fit the fax on a single sheet, it will be printed on separate sheets without being reduced.</p>	<ul style="list-style-type: none"> • Off • On <p>Default: [On]</p> <p>Default may be [Off] depending on the [Country] setting under [Administrator Tools].</p>
No. of Rings (TAD)	Specifies the number of times the external telephone answering device rings before the machine starts to receive faxes in FAX/TAD mode.	1 to 20 times, in increments of 1 Default: 5 times
Number of Rings	Specifies the number of times the machine rings before it starts to receive faxes in Fax Only mode.	3 to 5 times Default: 3 times
RX Mode Switch Time	Specifies how long the machine rings before it starts to receive faxes in FAX/TEL(Auto) mode.	5 to 99 seconds Default: 15 seconds
Authorized Reception	Sets the machine to receive (or reject) faxes only from the programmed Special Senders. This helps you screen out unwanted documents, such as junk faxes, and prevents the wasting of fax paper.	<ul style="list-style-type: none"> • Active • Inactive <p>Default: [Inactive]</p>
Auth.RX: Conditions	<p>Specifies whether to receive or reject faxes from the programmed Special Senders.</p> <p>This setting is available when [Authorized Reception] is enabled.</p>	<ul style="list-style-type: none"> • Special Sender Receive faxes from the Special Senders and reject faxes from all other senders. • Not Special Sender Reject faxes from the Special Senders and receive faxes from all other senders. <p>Default: [Special Sender]</p>

Item	Description	Value
<p>Reception File Sett.</p>	<p>Sets the machine to store received faxes into memory for printing or forward them to a preset destination.</p> <p>Use Web Image Monitor to specify the forwarding destination (for details, see page 276 "Configuring the System Settings").</p> <p>This setting appears only for M C250FW.</p>	<ul style="list-style-type: none"> • Print • Forward <p>Default: [Print]</p>
<p>Print Received File</p>	<p>Sets the machine to automatically print the faxes received into memory or store them for later manual printing.</p> <p>This setting appears only for M C250FW.</p>	<ul style="list-style-type: none"> • On <p>Automatically print out the received faxes and delete from memory.</p> <p>The machine prints out the received faxes and deletes them from memory within the specified time.</p> <ul style="list-style-type: none"> • Off <p>Store the received faxes in memory for manual printing specified time.</p> <p>Default: [On]</p>
<p>Print Forwarded File</p>	<p>Sets the machine to store the faxes in memory for printing or delete them after forwarding.</p> <p>This setting appears only for M C250FW.</p>	<ul style="list-style-type: none"> • On <p>Store the faxes in memory for printing after forwarding.</p> <ul style="list-style-type: none"> • Off <p>Delete the faxes from memory after forwarding.</p> <p>Default: [Off]</p>

Item	Description	Value
Notify Forwarding	<p>Sets the machine to send e-mail notifications after faxes are forwarded. The e-mail notification destination depends on how the forwarding destination is configured using Web Image Monitor (for details, see page 276 "Configuring the System Settings").</p> <p>This setting appears only for M C250FW.</p>	<ul style="list-style-type: none"> • Inactive • Active <p>Default: [Inactive]</p>
Manual POP	<p>Connects to the POP3 server to receive e-mail messages manually.</p> <p>Press [Yes] to connect to the POP3 server and receive e-mail messages. Press [No] to exit to the previous level of the menu tree without connecting to the POP3 server.</p> <p>This setting appears only for M C250FW.</p>	-
Duplex Print	<p>Specify whether or not received fax documents are to be printed on both sides of the paper.</p>	<ul style="list-style-type: none"> • Off • Duplex Portrait: T to T • Duplex Portrait: T to B <p>Default: [Off]</p>

Select Paper Tray

Item	Description	Value
Select Paper Tray	<p>Specifies the tray for printing received faxes.</p> <p>Note that only A4, Letter, or Legal size paper can be used for printing faxes.</p> <p>Make sure to select a tray that contains paper of the valid size.</p> <p>If Tray 2 is not installed, only [Tray 1] appears.</p>	<ul style="list-style-type: none"> • Auto <p>The machine uses Tray 1 and Tray 2 if they contain paper of the same size. In this case, the machine starts to print from the tray specified as the priority tray in [Paper Tray Priority] under [Paper Settings]. If that tray runs out of paper, the machine automatically switches to the other tray to continue printing.</p> <ul style="list-style-type: none"> • Tray 1 • Tray 2 <p>Default: [Auto]</p>

7

Delete TX Stand.File

Deletes unsent fax jobs remaining in the machine's memory. The machine can store up to 5 unsent fax jobs. This function is only performed when selected.

Item	Description	Value
Delete Selected File	To delete a fax job, select the desired job, press [Delete], and then press [Yes]. Pressing [Exit] without pressing [Delete] exits to the previous level of the menu tree without deleting the fax job.	-
Delete All Files	To delete the fax jobs, press [Delete All], and then press [Yes]. Pressing [Exit] without pressing [Delete All] exits to the previous level of the menu tree without deleting the fax jobs.	-

Communication Sett.

Item	Description	Value
ECM Transmission	Sets the machine to automatically resend parts of the data that are lost during transmission.	<ul style="list-style-type: none"> • Off • On Default: [On]
ECM Reception	Sets the machine to automatically receive parts of the data that are lost during reception.	<ul style="list-style-type: none"> • Off • On Default: [On]
Dial Tone Detect	Sets the machine to detect a dial tone before the machine begins to dial the destination automatically.	<ul style="list-style-type: none"> • Detect • Not Detect Default: [Detect]
Transmission Speed	Specifies the transmission speed for the fax modem.	<ul style="list-style-type: none"> • 33.6 Kbps • 14.4 Kbps • 9.6 Kbps • 7.2 Kbps • 4.8 Kbps • 2.4 Kbps Default: [33.6 Kbps]
Reception Speed	Specifies the reception speed for the fax modem.	<ul style="list-style-type: none"> • 33.6 Kbps • 14.4 Kbps • 9.6 Kbps • 7.2 Kbps • 4.8 Kbps • 2.4 Kbps Default: [33.6 Kbps]
JBIG	<p>Enables transmission and reception of JBIG-compressed images.</p> <p>Note that to use this function, [ECM] [Transmission] and [ECM Reception] must also be enabled.</p> <p>This function is not available with Internet Fax.</p>	<ul style="list-style-type: none"> • Active • Inactive Default: [Active]

Report Print Setting

Item	Description	Value
<p>Print TX Status</p>	<p>Sets the machine to print a transmission report automatically after a fax transmission.</p> <p>When the machine is in Immediate Transmission mode, the image of the original will not be reproduced on the report, even if [Error Only(Image)] or [Every TX (Image)] is selected.</p> <p>Note that if a memory error occurs for LAN-Fax transmission, a transmission report will always be printed regardless of this setting.</p> <p>The transmission report will be printed on A4 or Letter size paper.</p>	<ul style="list-style-type: none"> • Error Only Prints a report when a transmission error occurs. • Error Only(Image) Prints a report with an image of the original when transmission error occurs. • Every TX Prints a report for every fax transmission. • Every TX (Image) Prints a report with an image of the original for every fax transmission. • Do not Print <p>Default: [Every TX (Image)]</p>
<p>Print Fax Journal</p>	<p>Sets the machine to print a fax journal automatically for every 50 fax jobs (both sent and received).</p> <p>This machine's fax transmission history is deleted after printing each fax journal.</p> <p>The fax journal will be printed using the tray set for [Facsimile] under [Paper Tray Priority] in [Paper Settings], on A4 or Letter size paper.</p>	<ul style="list-style-type: none"> • Auto Print • Do not Auto Print <p>Default: [Auto Print]</p>

Transmission Setting

Item	Description	Value
Immediate TX	Sets the machine to send a fax immediately when the original is scanned.	<ul style="list-style-type: none"> • Off Select this when using Memory Transmission. • On Select this when using Immediate Transmission. • Next Fax Only Select this when using Immediate Transmission for the next transmission only. Default: [Off]
Resolution	Specifies the resolution to use for scanning originals. "Photo" resolution is not available for Internet Faxes. Faxes will be sent using "Detail" resolution if "Photo" resolution has been specified.	<ul style="list-style-type: none"> • Standard Select this when the original is a printed or typewritten document with normal-sized characters. • Detail Select this when the original is a document with small print. • Photo Select this when the original contains images such as photographs or shaded drawings. Default: [Standard]
Density	Specifies the image density to use for scanning originals.	Press [▶] to increase the density. Default: The default setting is the middle of 3 adjustment levels.
Pause Time	Specifies the length of pause time when a pause is inserted between the digits of a fax number.	1 to 15 seconds Default: 3 seconds

Item	Description	Value
Auto Redial	Sets the machine to redial the fax destination automatically when the line is busy or a transmission error occurs, if the machine is in Memory Transmission mode. The number of redial attempts is preset to two or three times, depending on the [Country] setting under [Administrator Tools], in five-minute intervals.	<ul style="list-style-type: none"> • Off • On Default: [On]
Print Fax Header	Sets the machine to add a header to every fax you send. The header includes the current date and time, user fax name and fax number of the machine, job ID, and page information.	<ul style="list-style-type: none"> • Off • On Default: [On]
Fax Original	Specifies the orientation to fax and whether to have faxes printed in both sides.	<ul style="list-style-type: none"> • Simplex Portrait • Dup. Portrait: T to T • Dup. Portrait: T to B • Dup. Landscape: T to T • Dup. Landscape: T to B Default: [Simplex Portrait]

Address Book

Item	Description	Value
Quick Dial List	Specifies the fax number and name for Quick Dial entries. You can register up to 20 Quick Dial entries.	<ul style="list-style-type: none"> • No. Specifies the Quick Dial number. • Name Specifies the name for Quick Dial entries. The name can contain up to 20 characters. • Number: Specifies the fax number for Quick Dial entries. The fax number can contain up to 40 characters, including 0 to 9, pause, "*", "#", and space.
Speed Dial List	Specifies the fax number and name for Speed Dial entries. You can register up to 200 Speed Dial entries.	<ul style="list-style-type: none"> • No. Specifies the Speed Dial number. • Name Specifies the name for Speed Dial entries. The name can contain up to 20 characters. • Number: Specifies the fax number for Speed Dial entries. The fax number can contain up to 40 characters, including 0 to 9, pause, "*", "#", and space.

System Settings

Adjust Sound Volume

Specifies the volume of the sounds produced by the machine.

Item	Description	Value
Panel Key Sound	Specifies the volume of the beep that sounds when a key is pressed.	<ul style="list-style-type: none"> • Off • Low • Middle • High Default: [Low]
Ring Volume	Specifies the volume of the ringing tone.	<ul style="list-style-type: none"> • Off • Low • Middle • High Default: [Middle]
On Hook Mode	Specifies the volume of the sound from the speaker during on hook mode.	<ul style="list-style-type: none"> • Off • Low • Middle • High Default: [Middle]
Job End Tone	Specifies the volume of the beep that sounds when a job is complete.	<ul style="list-style-type: none"> • Off • Low • Middle • High Default: [Middle]
Job Error Tone	Specifies the volume of the beep that sounds when a fax transmission error occurs.	<ul style="list-style-type: none"> • Off • Low • Middle • High Default: [Middle]

Item	Description	Value
Alarm Volume	Specifies the volume of the alarm that sounds when an operation error occurs.	<ul style="list-style-type: none"> • Off • Low • Middle • High Default: [Middle]

I/O Timeout

Item	Description	Value
USB	Specifies how many seconds the machine waits for print data, if the data is interrupted while it is being sent from the computer via USB. If the machine does not receive any more data within the time specified here, the machine only prints the data it has received. If printing is frequently interrupted by data from other ports, increase the timeout period.	<ul style="list-style-type: none"> • 15 sec. • 60 sec. • 300 sec. Default: [60 sec.]
Network	Specifies how many seconds the machine waits for print data, if the data is interrupted while it is being sent from the computer via network. If the machine does not receive any more data within the time specified here, the machine only prints the data it has received. If printing is frequently interrupted by data from other ports, increase the timeout period.	<ul style="list-style-type: none"> • 15 sec. • 60 sec. • 300 sec. Default: [60 sec.]

Item	Description	Value
Locked Print	<p>Specifies how many seconds the machine holds a new Locked Print file, when the machine cannot store any more Locked Print files. Within this time, you can print or delete the new Locked Print file. You can also print or delete an existing Locked Print file so that the new Locked Print file can be stored in the machine.</p> <p>This setting appears only for M C250FW.</p>	<ul style="list-style-type: none">• 0 to 300 seconds, in increments of 1 second <p>Default: [60 seconds]</p>
User Auth. (Copy)	<p>Specifies how many seconds a user stays authenticated after paper is output when copying with the exposure glass. Note that authentication for other functions will expire immediately after using that function.</p> <p>This setting appears only for M C250FW (when the user restriction function is enabled via Web Image Monitor).</p>	<ul style="list-style-type: none">• 5 to 60 seconds, in increments of 1 second <p>Default: [30 seconds]</p>

Item	Description	Value
Fixed USB Port	Specifies whether the same printer/ LAN-Fax driver can be used for multiple machines or not under USB connection.	<ul style="list-style-type: none"> • Off You must install the printer/ LAN-Fax driver separately for individual machines, because the machine other than the original will be recognized as a new device upon USB connection. • On The same printer/LAN-Fax driver you have installed in your computer can be used with any machine other than the one originally used for installation, if the machine is of the same model. <p>Default: [Off]</p>
Export to NFC	<p>Specifies whether or not to synchronize the data you have configured using the control panel and Web Image Monitor with the data stored in NFC.</p> <p>You can read and write the data in NFC by using the application corresponding to the machine.</p>	<ul style="list-style-type: none"> • Off Does not synchronize the data you have configured using the control panel and Web Image Monitor with the data stored in NFC. • On Synchronizes the data you have configured using the control panel and Web Image Monitor with the data stored in NFC. <p>Default: [On]</p>

Auto Continue

Item	Description	Value
Auto Continue	<p>Sets the machine to ignore an error with paper size or type and continue printing. The printing stops temporarily when an error is detected, and restarts automatically after about ten seconds using the settings made on the control panel.</p> <p>However, if the size of paper specified on the control panel and that of the paper loaded in the paper tray or the paper size specified for the print job do not match when printing restarts, it may cause a paper jam.</p>	<ul style="list-style-type: none"> • Off • On <p>Default: [Off]</p>

Toner Saving

7

Item	Description	Value
Toner Saving	<p>Sets the machine to print using a reduced amount of toner (for prints made by the copier function only).</p>	<ul style="list-style-type: none"> • Off • On <p>Default: [Off]</p>

Color Registration

Item	Description
Color Registration	<p>Adjusts color registration as necessary. (This adjustment is usually executed by the machine automatically.)</p> <p>Press [Yes] to execute color registration adjustment.</p> <p>Press [No] to exit to the previous level of the menu tree without adjusting color registration.</p>

Auto Cleaning

Item	Description	Value
Auto Cleaning	Sets the machine to execute periodic cleaning of the interior. You may hear some noise while cleaning is being executed. This noise does not indicate a malfunction.	<ul style="list-style-type: none"> • On • Off Default: [On]

B&W Print Priority

Item	Description	Value
B&W Print Priority	<p>Sets the machine to suppress the consumption of color toner when printing black-and-white pages.</p> <p>Also, the amount of color toner consumed during warm-up time for maintenance will also be lowered. Note that the default value for this setting will not be restored by performing [Reset All Settings] under [Administrator Tools] or [Reset Settings] under [Administrator Tools] of Web Image Monitor.</p>	<ul style="list-style-type: none"> • On • Off Default: [Off]

Toner Almost Empty

Item	Description	Value
Toner Almost Empty	<p>Specifies the low toner level notification timing.</p> <p>Note that the default value for this setting will not be restored by performing [Reset All Settings] under [Administrator Tools] or [Reset Menu Settings] under [Administrator Tools] of Web Image Monitor.</p>	<ul style="list-style-type: none"> • Sooner Low toner level notification will be made when the number of pages that can be printed with the remaining toner is approximately 300. • Normal Low toner level notification will be made when the number of pages that can be printed with the remaining toner is approximately 200. • Later Low toner level notification will be made when the number of pages that can be printed with the remaining toner is approximately 100. <p>Default: [Normal]</p>
 Region A (mainly Europe) Auto Power Off	<p>The machine shuts down automatically if it remains in energy saver mode and does not connect to the host for 2 hours or more.</p>	<ul style="list-style-type: none"> • Off • On <p>Default: [On]</p>

Fixing Quality Mode

Item	Description	Value
Fixing Quality Mode	Set this item to [Fixing Quality Improved] to increase the toner fusibility in order to improve its adherence, etc.	<ul style="list-style-type: none">• Normal• Fixing Quality Improved Default: [Normal]

Curl Prevention Mode

Item	Description	Value
Curl Prevention Mode	Set this to [Curl Prevented] to reduce paper curl.	<ul style="list-style-type: none">• Normal• Curl Prevented Default: [Normal]

Printer Settings

List/Test Print

Prints lists showing configurations on the machine.



The lists will be printed using the tray set for [Printer] under [Paper Tray Priority] in [Paper Settings] on A4 or Letter size paper.

Item	Description
Configuration Page	Prints general information and the current configurations of the machine.
Menu List	Prints the machine's function menus.
Test Page	Prints a test page for checking the single-sided printing condition. The test page contains network settings.
PCL Font List	Prints installed PCL font list.
PS Font List	Prints installed PostScript font list.

7



System

Item	Description	Value
Copies	<p>Sets the machine to print the specified number of sets.</p> <p>This setting is disabled if the number of pages to print is specified by the printer driver.</p>	<p>1 to 999</p> <p>Default: 1</p>
Sub Paper Size	<p>Sets the machine to print onto paper of another size if the specified paper is not loaded in any tray. Alternative sizes are preset to A4 and Letter.</p>	<ul style="list-style-type: none"> • Auto • Off <p>Default: [Off]</p>

Item	Description	Value
Default Page Size	Specifies the paper size to be used when the paper size is not specified in the print job.	<p>A4, A5, A6, 8¹/₂ × 11, 7¹/₄ × 10¹/₂, 8¹/₂ × 13, 16K, 3⁷/₈ × 7¹/₂, C6 Env, B5 JIS, B6 JIS, 8¹/₂ × 14, 5¹/₂ × 8¹/₂, 8 × 13, 8¹/₄ × 13, 4¹/₈ × 9¹/₂, C5 Env, A5 LEF, 8¹/₂ × 13²/₅, 8¹/₂ × 13³/₅, DL Env</p> <p> Region A</p> <p>Default: [A4]</p> <p> Region B</p> <p>Default: [8¹/₂ × 11]</p>
Duplex	Sets the machine to print on both sides of paper according to the specified binding method.	<ul style="list-style-type: none"> • None • Long Edge Bind • Short Edge Bind <p>Default: [None]</p>
Blank Page Print	<p>Sets the machine to print blank pages.</p> <p>When cover sheet printing is enabled from the printer driver, cover sheets are inserted even if you select [Off].</p> <p>Note that this setting has lower priority than the PostScript 3 printer driver's blank page setting.</p>	<ul style="list-style-type: none"> • On • Off <p>Default: [On]</p>
B&W Page Detect	Sets the machine to print all monochrome pages in monochrome mode even if color printing is specified.	<ul style="list-style-type: none"> • On • Off <p>Default: [On]</p>
Print Error Report	Sets the machine to print an error page when the machine detects a printer or memory error.	<ul style="list-style-type: none"> • On • Off <p>Default: [Off]</p>

PCL Menu

Specifies conditions when using PCL for printing.

Item	Description	Value
Orientation	Specifies the page orientation.	<ul style="list-style-type: none"> • Portrait • Landscape Default: [Portrait]
Form Lines	Specifies the number of lines per page.	5 to 128  Region A Default: 64  Region B Default: 60
Font Number	Specifies the ID of the default font you want to use.	0 to 89 Default: 0
Point Size	Specifies the point size for the default font. This setting is effective only for a variable-space font.	4.00 to 999.75 Default: 12.00 points You can change the value in 0.25 increments.
Font Pitch	Specifies the number of characters per inch for the default font. This setting is effective only for fixed-space fonts.	0.44 to 99.99 Default: 10.00 pitch
Symbol Set	Specifies the character set for the default font. The following sets are available:	Roman-8, Roman-9, ISO L1, ISO L2, ISO L5, PC-8, PC-8 D/N, PC-850, PC-852, PC-858, PC8-TK, Win L1, Win L2, Win L5, Desktop, PS Text, VN Intl, VN US, MS Publ, Math-8, PS Math, VN Math, Pifont, Legal, ISO 4, ISO 6, ISO 11, ISO 15, ISO 17, ISO 21, ISO 60, ISO 69, Win 3.0, MC Text, ISO L6, ISO L9, PC-775, PC-1004, Win Baltic Default: [PC-8]
Courier Font	Specifies a courier-type font.	<ul style="list-style-type: none"> • Regular • Dark Default: [Regular]







Item	Description	Value
Extend A4 Width	Sets the machine to extend the width of the printable area of A4 size paper, reducing side margin width.	<ul style="list-style-type: none"> • On • Off Default: [Off]
Append CR to LF	Sets the machine to append a CR code to each LF code to print text data clearly.	<ul style="list-style-type: none"> • On • Off Default: [Off]
PCL Resolution	Specifies the print resolution in dots per inch.	<ul style="list-style-type: none"> • 600 × 600 1bit • 600 × 600 2bit • 600 × 600 4bit Default: [600 × 600 1bit]

PS Menu

Specifies conditions when using PostScript for printing.

Item	Description	Value
PS Resolution	Specifies the print resolution in dots per inch.	<ul style="list-style-type: none"> • 600 × 600 1bit • 600 × 600 2bit • 600 × 600 4bit Default: [600 × 600 1bit]
Color Profile	Specifies the color profile.	<ul style="list-style-type: none"> • Solid Color • Presentation • Photographic • Off Default: [Solid Color]

Paper Settings

Item	Description	Value
Paper Size: Tray 1		<p>A4, B5 JIS, A5, B6 JIS, A6, 8¹/₂ × 14, 8¹/₂ × 11, 5¹/₂ × 8¹/₂, 7¹/₄ × 10¹/₂, 8 × 13, 8¹/₂ × 13, 8¹/₄ × 13, 16K, 4¹/₈ × 9¹/₂, 3⁷/₈ × 7¹/₂, C5 Env, C6 Env, DL Env, A5 LEF, 8¹/₂ × 13²/₅, 8¹/₂ × 13³/₅, Custom Size</p> <p> Region A</p> <p>Default: [A4]</p> <p> Region B</p> <p>Default: [8¹/₂ × 11]</p>
Paper Size: Tray 2	<p>Specifies the paper size for Tray 2.</p> <p>This setting appears only when the optional paper feed unit is installed.</p>	<ul style="list-style-type: none"> • A4 • 8¹/₂ × 11 <p> Region A</p> <p>Default: [A4]</p> <p> Region B</p> <p>Default: [8¹/₂ × 11]</p>
Paper Size: Bypass		<p>A4, B5 JIS, A5, B6 JIS, A6, 8¹/₂ × 14, 8¹/₂ × 11, 5¹/₂ × 8¹/₂, 7¹/₄ × 10¹/₂, 8 × 13, 8¹/₂ × 13, 8¹/₄ × 13, 16K, 4¹/₈ × 9¹/₂, 3⁷/₈ × 7¹/₂, C5 Env, C6 Env, DL Env, A5 LEF, 8¹/₂ × 13²/₅, 8¹/₂ × 13³/₅, Custom Size</p> <p> Region A</p> <p>Default: [A4]</p> <p> Region B</p> <p>Default: [8¹/₂ × 11]</p>

Item	Description	Value
Paper Type: Tray 1	Specifies the paper type for tray 1.	<ul style="list-style-type: none"> • Thin Paper • Plain Paper 1 • Plain Paper 2 • Middle Thick Paper • Thick Paper 1 • Recycled Paper • Color Paper • Letterhead • Preprinted Paper • Prepunched Paper • Label Paper • Bond Paper • Cardstock • Envelope • Thick Paper 2 Default: [Plain Paper 2]
Paper Type: Tray 2	Specifies the paper type for Tray 2. This setting appears only when the optional paper feed unit is installed.	<ul style="list-style-type: none"> • Thin Paper • Plain Paper 1 • Plain Paper 2 • Middle Thick Paper • Thick Paper 1 • Recycled Paper • Color Paper • Letterhead • Preprinted Paper • Prepunched Paper Default: [Plain Paper 2]

Item	Description	Value
Paper Type: Bypass	Specifies the paper type for bypass tray.	<ul style="list-style-type: none"> • Thin Paper • Plain Paper 1 • Plain Paper 2 • Middle Thick Paper • Thick Paper 1 • Recycled Paper • Color Paper • Letterhead • Prepunched Paper • Label Paper • Bond Paper • Cardstock • Envelope • Thick Paper 2 <p>Default: [Plain Paper 2]</p>
Tray 1 Priority	Specifies how print jobs using Tray 1 are handled.	<ul style="list-style-type: none"> • Machine Setting(s) The paper settings configured on the machine's control panel are applied to all print jobs. An error occurs when the paper settings specified by the printer driver or the print command do not match the machine's settings. • Driver/Command When executing a print job specifying the paper tray, the paper settings specified in the printer driver or in the print command are applied regardless of the machine's settings. <p>Default: [Driver/Command]</p>

Item	Description	Value
Bypass Tray Priority	Specifies how print jobs using the bypass tray are handled.	<ul style="list-style-type: none"> <li data-bbox="677 309 1218 544">• Machine Setting(s) The machine prints all print jobs according to the machine's settings. An error will occur if the paper size/type settings of the machine and printer driver do not match. <li data-bbox="677 560 1218 746">• Driver/Command When executing a print job specifying the paper tray, the paper settings specified in the printer driver or in the print command are applied regardless of the machine's settings. <li data-bbox="677 762 1218 1030">• Any Size/Type The machine prints all print jobs according to the printer driver's settings. Printing proceeds even if the paper size/type settings of the machine and printer driver do not match. However, if the paper is too small for the print job, the printed image will be cropped.
		<ul style="list-style-type: none"> <li data-bbox="677 1060 1218 1550">• Any Custom Size/Type The machine prints custom size print jobs according to the printer driver's settings and prints standard size print jobs according to the machine's settings. For custom size print jobs, printing proceeds even if the paper size/type settings of the machine and printer driver do not match. However, if the paper is too small for the print job, the printed image will be cropped. For standard size print jobs, an error will occur if the paper size/type settings of the machine and printer driver do not match. <p data-bbox="653 1569 941 1599">Default: [Driver/Command]</p>

Item	Description	Value
Paper Tray Priority	<p>Specifies the tray that the machine uses first for print jobs, printing out copies, or printing out faxes, from Tray 1 or Tray 2.</p> <p>If multiple trays contain valid paper, the first tray the machine finds will be used for printing; when that tray runs out of paper, the machine automatically switches to the next tray to continue printing.</p> <p>If Tray 2 is not installed, [Tray 2] does not appear.</p>	<ul style="list-style-type: none"> • Printer <p>If automatic tray selection is specified for the print job and both tray 1 and tray 2 contain paper that matches the print job, the machine starts to print from the specified tray.</p> <ul style="list-style-type: none"> • Tray 1 • Tray 2 • Copier <p>Selects a tray to check first when [A4], or [8¹/₂ × 11] is selected for [Select Paper] under copy settings and both tray 1 and tray 2 contain paper of that size, the machine starts to print from the specified tray.</p> <ul style="list-style-type: none"> • Tray 1 • Tray 2 • Facsimile <p>[Auto] is selected for [Select Paper Tray] under fax feature settings, and both Tray 1 and Tray 2 contain paper of the same size, the machine starts to print from the specified tray.</p> <ul style="list-style-type: none"> • Tray 1 • Tray 2 Default: [Tray 1]
Size Mismatch Detect.	<p>Sets the machine to report an error if the paper size does not match the print job's settings.</p>	<ul style="list-style-type: none"> • Invalid • Valid Default: [Valid]

Administrator Tools Settings

Item	Description	Value
Set Date/Time	Sets the date and time of the machine's internal clock. (Default may differ depending on the [Country] setting under [Administrator Tools].)	<ul style="list-style-type: none"> • Set Date Specifies the date of the machine's internal clock. Only dates that correspond with the year and month can be set. Incompatible dates will be refused. Default date format: [Day/Month/Year] <ul style="list-style-type: none"> • Date format: Month/Day/Year, Day/Month/Year, or Year/Month/Day Year: 2000 to 2099 Month: 1 to 12 Day: 1 to 31 • Set Time Sets the time of the machine's internal clock. Default date format: [24-hour Format] <ul style="list-style-type: none"> • Time format: 12-hour Format, 24-hour Format AM/PM stamp: AM, PM (for 12-hour Format) Hour: 0 to 23 (for 24-hour Format), or 1 to 12 (for 12-hour Format) Minute: 0 to 59
Program Fax Info.	Specifies the fax name and fax number of the machine.	<ul style="list-style-type: none"> • Number: Specifies the fax number of the machine using up to 20 characters, including 0 to 9, space, and "+". • Name: Specifies the fax name of the machine using up to 20 alphanumeric characters and symbols.

Item	Description	Value
Dial/Push Phone	<p>Specifies the line type of the telephone line.</p> <p>To configure this setting, contact your telephone company and select the setting based on your telephone line. Selecting a wrong setting may cause failures in fax transmissions.</p> <p>[Dial Phone (2OPPS)] appears only if the country is set to [Thailand].</p>	<ul style="list-style-type: none"> • Push Phone • Dial Phone (10PPS) • Dial Phone (20PPS) <p>Default: [Push Phone]</p>
PSTN / PBX	<p>Sets the machine to connect to the public switched telephone network (PSTN) or a private branch exchange (PBX).</p>	<ul style="list-style-type: none"> • PSTN • PBX <p>Default: [PSTN]</p>
External Access No.	<p>Specifies the dial number to access the outside line when the machine is connected to a PBX.</p> <p>Make sure that this setting matches the setting of your PBX. Otherwise, you may not be able to send faxes to outside destinations.</p>	<p>0 to 999</p> <p>Default: 9</p>
Function Priority	<p>Specifies the mode that is activated when the power is turned on, or if the time specified for [System Reset Timer] elapses without activity while the initial screen of the current mode is displayed.</p>	<ul style="list-style-type: none"> • Home • Copier • Facsimile • Scanner <p>Default: [Home]</p>

Item	Description	Value
System Reset Timer	<p>Sets the machine to return to the mode specified in [Function Priority].</p> <p>This setting is also applied to the timeout for copying the next document while ID card copy and manual 2-sided copy is performed.</p>	<ul style="list-style-type: none"> • 30 sec. • 1 min. • 2 min. • 3 min. • 5 min. • 10 min. • Off <p>Default: [1 min.]</p>
Energy Saver Mode	<p>Sets the machine to enter Energy Saver mode, Energy Saver mode 1 or Energy Saver mode 2, to reduce power consumption. The machine recovers from Energy Saver mode when it receives a print job, prints a received fax, or one of the keys on the control panel is pressed.</p> <p>Regardless of the settings for EnergySaverMode 1 or EnergySaverMode 2, the machine enters EnergySaverMode 1 after being idle for 10 minutes.</p>	<ul style="list-style-type: none"> • EnergySaverMode 1 <p>The machine enters Energy Saver mode 1 if the machine has been idle for about 30 seconds. It takes less time to recover from Energy Saver mode 1 than from power-off state or Energy Saver mode 2, but power consumption is higher in Energy Saver mode 1 than in Energy Saver mode 2.</p> <ul style="list-style-type: none"> • Off • On <p>Default: [Off]</p>

Item	Description	Value
Energy Saver Mode	<p>Sets the machine to enter Energy Saver mode, Energy Saver mode 1 or Energy Saver mode 2, to reduce power consumption. The machine recovers from Energy Saver mode when it receives a print job, prints a received fax, or one of the keys on the control panel is pressed.</p> <p>Regardless of the settings for EnergySaverMode 1 or EnergySaverMode 2, the machine enters EnergySaverMode 1 after being idle for 10 minutes.</p>	<ul style="list-style-type: none"> • EnergySaverMode 2 <p>The machine enters Energy Saver mode 2 after the period of time specified for this setting is passed. The machine consumes less power in Energy Saver mode 2 than in Energy Saver mode 1, but it takes longer to recover from Energy Saver mode 2 than from Energy Saver mode 1.</p> <p>1 to 60 minutes</p> <p>Default: 1 minute</p>

Item	Description	Value
Language	<p>Specifies the language used on the screen and in reports.</p> <p>The default value for this setting is the language you have specified during the Initial Setup, which is required after turning on the machine for the first time.</p>	<ul style="list-style-type: none">• English• German• French• Italian• Spanish• Dutch• Swedish• Norwegian• Danish• Finnish• Portuguese• Czech• Hungarian• Polish• Simplified Chinese• Russian• Brazilian Portuguese• Turkish• Traditional Chinese• Arabic

Item	Description	Value
Country	<p>Selects the country in which the machine is used. The country code you specify determines the time and date display format and the default values of the fax transmission-related settings.</p> <p>Make sure to select the country code correctly. Selecting a wrong country code may cause failures in fax transmissions.</p> <p>The default value for this setting is the country code you have specified during the Initial Setup, which is required after turning on the machine for the first time.</p>	<p>Algeria, Argentina, Australia, Austria, Belgium, Bolivia, Brazil, Bulgaria, Canada, Chile, China, Colombia, Costa Rica, Croatia, Cyprus, Czech Republic, Denmark, Dominican Republic, Ecuador, Egypt, El Salvador, Estonia, Finland, France, Germany, Greece, Guam, Guatemala, Honduras, Hong Kong, Hungary, Iceland, India, Ireland, Israel, Italy, Japan, Jordan, Kuwait, Latvia, Lebanon, Liechtenstein, Lithuania, Luxembourg, Malaysia, Malta, Mexico, Montenegro, Morocco, Netherlands, New Zealand, Nicaragua, Nigeria, Norway,</p>
Country	<p>Selects the country in which the machine is used. The country code you specify determines the time and date display format and the default values of the fax transmission-related settings.</p> <p>Make sure to select the country code correctly. Selecting a wrong country code may cause failures in fax transmissions.</p> <p>The default value for this setting is the country code you have specified during the Initial Setup, which is required after turning on the machine for the first time.</p>	<p>Oman, Panama, Paraguay, Peru, Philippines, Poland, Portugal, Puerto Rico, Romania, Russia, Saudi Arabia, Senegal, Serbia, Singapore, Slovakia, Slovenia, South Africa, Spain, Sri Lanka, Sweden, Switzerland, Taiwan, Thailand, Trinidad and Tobago, Tunisia, Turkey, UAE, UK, Uruguay, USA, Venezuela, Vietnam, Virgin Islands, Yemen</p>

Item	Description	Value
Reset Settings	Be sure not to clear the settings by mistake.	<ul style="list-style-type: none"> • Reset All Settings Resets the machine's settings to their defaults except the following: <ul style="list-style-type: none"> • Language settings • Country settings • Network settings • Fax destinations Press [Yes] to execute. Press [No] to exit to the previous level of the menu tree without clearing the settings. • Reset Network Sett. Resets the network settings to their defaults. Press [Yes] to execute. Press [No] to exit to the previous level of the menu tree without clearing the settings. • Clear Address Book Clears the fax Quick Dial/Speed Dial destinations. Press [Yes] to execute. Press [No] to exit to the previous level of the menu tree without clearing the destinations.
Admin. Tools Lock	Specifies a four-digit password for accessing the [Address Book], [Network Settings], [Setup Wizard], and [Administrator Tools] menus. Do not forget this password.	<ul style="list-style-type: none"> • On (0000 to 9999) • Off Default: [Off]
IPSec	Selects whether to enable or disable IPsec. This function appears only when a password is specified under [Admin. Tools Lock].	<ul style="list-style-type: none"> • Inactive • Active Default: [Inactive]

Item	Description	Value
Fax No. Confirmation	<p>Sets the machine to require a fax number to be entered twice when specifying a destination manually.</p> <p>When this function is enabled, you cannot use the On Hook Dial function.</p> <p>This function appears only when a password is specified under [Admin. Tools Lock].</p>	<ul style="list-style-type: none"> • On • Off <p>Default: [Off]</p>
Save Scn Data to USB	<p>Specify whether to enable or disable Scan to USB.</p> <p>This function appears only when a password is specified under [Admin. Tools Lock].</p>	<ul style="list-style-type: none"> • Inactive • Active <p>Default: [Active]</p>

Printing Lists/Reports

Printing the Configuration Page

1. Press the [Home] key.

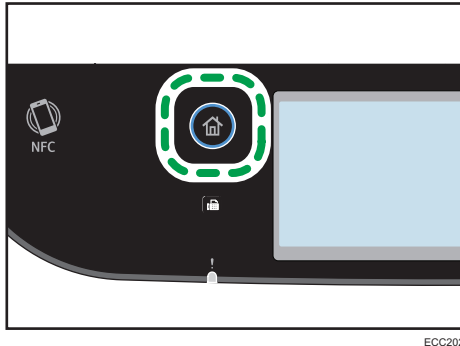

2. Press the [Setting] icon on the [Home] screen.
3. Press [Print List/Report].
4. Press [Configuration Page].
5. Press [Yes].

Types of Lists/Reports

Note

- Reports will be printed on A4 or Letter size paper. Load one of these sizes of paper into the tray before printing reports.

Configuration Page

Prints general information and the current configurations of the machine.

Fax Journal

Prints a fax transmission and reception journal for the last 50 jobs.

TX/RX Standby Files

Prints a list of fax jobs remaining in the machine's memory to be printed, sent, or forwarded.

Quick Dial Dest.

Prints a list of scan and fax Quick Dial entries.

Fax Speed Dial Dest.

Prints a list of Speed Dial entries.

- **By Speed Dial No.**
Prints the list with the entries sorted by Speed Dial registration number.
- **By Name**
Prints the list with the entries sorted by name.

Scanner Dest. List

Prints a list of scan destinations.

Scanner Journal

Prints a scanner journal for the last 100 Scan to E-mail, Scan to FTP, and Scan to Folder transmissions.

Maintenance Page

Prints the maintenance page.

Special Sender List

Prints a list of fax Special Senders.

Network Settings

★ Important

- Depending on the settings you change, the machine might need to be restarted.
- Depending on the model you are using, some items might not appear.

Wi-Fi Enable

Item	Description	Value
Wi-Fi Enable	Select whether to enable or disable Wireless LAN. If [Disable] is set, [Wi-Fi Configuration] is not displayed.	<ul style="list-style-type: none"> • Disable • Enable Default: [Disable]

Connection Mode

Item	Description	Value
Connection Mode	Select the network connection mode.	<ul style="list-style-type: none"> • Ethernet • Wi-Fi Default: [Ethernet]

Ethernet

Item	Description	Value
MAC Address	Displays the machine's MAC address.	–
Ethernet Speed	Displays the current Ethernet speed setting.	<ul style="list-style-type: none"> • 100Mbps Full Duplex • 100Mbps Half Duplex • 10Mbps Full Duplex • 10Mbps Half Duplex • No Ethernet Connection Appears when a network cable is not connected.

Item	Description	Value
Set Ethernet Speed	<p>Specifies the speed for Ethernet communication. Select a speed that matches your network environment.</p> <p>For most networks, the default setting is the optimum setting.</p>	<ul style="list-style-type: none">• Auto Select• 100Mbps Full Duplex• 100Mbps Half Duplex• 10Mbps Full Duplex• 10Mbps Half Duplex <p>Default: [Auto Select]</p>

IPV4 Configuration

Item	Description	Value
IPV4 DHCP	Sets the machine to receive its IPv4 address, subnet mask, and default gateway address automatically from a DHCP server.	<ul style="list-style-type: none"> Inactive Active Default: [Active]
		<ul style="list-style-type: none"> IP Address <p>Specifies the machine's IPv4 address when DHCP is not used.</p> <p>Use this menu to check the current IP address when DHCP is used.</p> <p>Default: 11.22.33.44</p> Subnet Mask <p>Specifies the machine's subnet mask when DHCP is not used.</p> <p>Use this menu to check the current subnet mask when DHCP is used.</p> <p>Default: 255.255.255.0</p> Gateway Address <p>Specifies the machine's default gateway address when DHCP is not used.</p> <p>Use this menu to check the current default gateway address when DHCP is used.</p> <p>Default: 11.22.33.44</p>
IP Address Method	Displays the IP address acquisition method.	<ul style="list-style-type: none"> IP not Ready DHCP Manual Configuration Default IP
Wi-Fi Direct IP Addr	Displays the IP address of Wi-Fi Direct.	–

IPv6 Configuration

Item	Description	Value
IPv6	Select whether to enable or disable IPv6.	<ul style="list-style-type: none"> • Inactive • Active Default: [Active]
IPv6 DHCP	Sets the machine to receive its IPv6 address from a DHCP server.	<ul style="list-style-type: none"> • Inactive • Active Default: [Inactive]
		<ul style="list-style-type: none"> • Manually Set Address Specifies the machine's IPv6 address when DHCP is not used. Can contain up to 46 characters. For details about entering characters, see page 42 "Entering Characters". • Prefix Length Specifies the prefix length, using a value between 0 and 128. • Gateway Address Specifies the IPv6 address of the default gateway. Can contain up to 46 characters. For details about entering characters, see page 42 "Entering Characters".
Stateless Address	Displays the IPv6 stateless addresses obtained from a Router Advertisement.	<ul style="list-style-type: none"> • Stateless Address 1 • Stateless Address 2 • Stateless Address 3 • Stateless Address 4
Link-local Address	Displays the IPv6 link local address.	–

Wi-Fi Configuration

Item	Description	Value
Wi-Fi Direct Type	Selects the Wi-Fi Direct type.	<ul style="list-style-type: none"> • 2.4 GHz • 5 GHz Default: [2.4 GHz]
Wi-Fi Direct	Enables devices to communicate directly with each other without using a central access point.	-
Wi-Fi Status	<ul style="list-style-type: none"> • Status Displays the current connection status. • Mac Address Displays the machine's MAC address. • SSID Displays detailed information about the SSID. 	-
Setup Wizard	Displays the procedure for manually connecting to a wireless LAN. It leads you step-by-step through configuring the settings for connecting with a wireless LAN.	-
WPS	Connects with one touch using WPS (Wi-Fi Protected Setup). For details, see Setup Guide.	<ul style="list-style-type: none"> • PBC • PIN
Wi-Fi Direct SSID	<ul style="list-style-type: none"> • Name Displays the current SSID of the machine. • Password Specify the password for Wi-Fi Direct connection. 	-

↓ Note

- Contact your network administrator for information about the network configuration.

@Remote

RC Gate Proxy Server

Item	Description	Value
RC Gate Proxy Server	Specify whether to use a proxy server.	<ul style="list-style-type: none"> • Off • On Default: [Off]
Proxy Address	Specify the proxy server address.	-
Port Number	Enter the port number for the proxy server.	(1 to 65535)
User Name	Enter the user name for logging in to the proxy server.	-
Password	Enter the password for logging in to the proxy server.	-

7

RC Gate Setup

Item	Description	Value
Request No.	Displays the request number issued by @Remote.	-
Reference	Refers to the machine's registration information.	-
RC Gate Location	Displays the location of the machine as a result of the reference function. Confirm the information and proceed with the registration.	-
Registration	Registers the machine to @Remote.	-

Note

- @Remote (At Remote) is an Internet-based support for remote management of digital multi-purpose devices and laser printers. For more information about the settings, contact your sales or service representative.

8. Configuring the Machine Using Utilities

This chapter describes how to configure the machine using utilities.

Available Setting Functions Using Web Image Monitor

Use Web Image Monitor to change the configuration of the machine from a computer.

Available operations for Web Image Monitor is as follows:

The following operations can be performed remotely using Web Image Monitor on a computer:

- Displaying the machine's status or settings
- Configuring the machine's settings
- Registering the scan and fax destinations
- Registering the fax Special Senders
- Configuring the user restriction settings
- Configuring the network settings
- Configuring the IPsec settings
- Printing reports
- Setting the administrator password and e-mail address
- Resetting the machine's configuration to the factory default
- Creating backup files of the machine's configuration
- Restoring the machine's configuration from backup files
- Configuring the machine's date and time
- Configuring the machine's Energy Saver mode setting

Using Web Image Monitor

★ Important

- Some items might not appear, depending on the model type you are using.
- Some items can also be configured using the control panel.

Recommended web browsers

- Internet Explorer 9 or later
- Microsoft Edge
- Google Chrome version 3.0 or later
- Firefox 3.0 or later
- Safari 4.0 or later

↓ Note

- To operate the machine via Web Image Monitor, you must first configure the machine's TCP/IP or wireless LAN settings. For details, see page 261 "Network Settings" or see page 293 "Configuring the Network Settings".

Displaying Top Page

When you access the machine using Web Image Monitor, the top page appears in your browser's window.

1. Launch the Web browser.
2. In the Web browser's address bar, enter "http://(machine's IP address)/" to access the machine.

If a DNS server is used and the machine's host name has been specified, you can enter the host name instead of the IP address.

The top page of Web Image Monitor appears.

Top page

Every Web Image Monitor page is divided into the following areas:

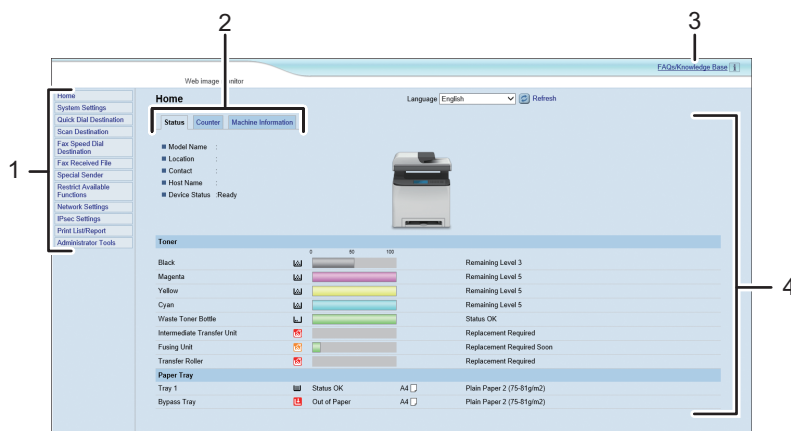

ECC264

1. Menu area
Clicking a menu shows its contents in the main area.
2. Tab area
Contains tabs for switching between information and settings you want to see or configure.
3. FAQs/Knowledge Base
Provides answers to frequently asked questions and other useful information about using this machine.
An internet connection is required to view this information.
4. Main area
Displays the contents of the item selected in the menu area.

Information in the main area is not automatically updated. Click [Refresh] at the upper-right in the main area to update the information. Click the Web browser's [Refresh] button to refresh the entire browser screen.

Note

- If you use an older version of a supported Web browser or the Web browser has JavaScript and cookies disabled, display and operation problems may occur.
- If you are using a proxy server, configure the Web browser settings as necessary. For details about the settings, contact your network administrator.
- The previous page may not appear even if the back button of the Web browser is clicked. If this happens, click the refresh button of the Web browser.
- The FAQs (Frequently Asked Questions)/Knowledge Base are not available in certain languages.

Changing the Interface Language

Select the desired interface language from the [Language] list.

Checking the System Information

Click [Home] to display the main page of Web Image Monitor. You can check the current system information on this page.

This page contains three tabs: [Status], [Counter], and [Machine Information].

Status Tab

Item	Description
Model Name	Shows the name of the machine.
Location	Shows the location of the machine as registered on the [SNMP] page.
Contact	Shows the contact information of the machine as registered on the [SNMP] page.
Host Name	Shows the host name specified in [Host Name] on the [DNS] page.
Device Status	Shows the current messages on the machine's display.

Toner

Item	Description
Black	Shows the amount of black toner remaining.
Magenta	Shows the amount of magenta toner remaining.
Yellow	Shows the amount of yellow toner remaining.
Cyan	Shows the amount of cyan toner remaining.
Waste Toner Bottle	Shows the remaining life of the waste toner bottle, as "Status OK", "Almost Full" or "Full".
Intermediate Transfer Unit	Shows the remaining life of the intermediate transfer unit, as "Status OK", "Replacement Required Soon" or "Replacement Required". For replacing, contact your sales or service representative.
Fusing Unit	Shows the remaining life of the fusing unit, as "Status OK", "Replacement Required Soon" or "Replacement Required". For replacing, contact your sales or service representative.

Item	Description
Transfer Roller	Shows the remaining life of the transfer roller, as "Status OK", "Replacement Required Soon" or "Replacement Required". For replacing, contact your sales or service representative.

Paper Tray

Item	Description
Tray 1	Shows the current state and paper size/type setting of Tray 1.
Tray 2	Shows the current state and paper size/type setting of Tray 2.
Bypass Tray	Shows the current state and paper size/type setting of the bypass tray.

Note

- If a non-genuine print cartridge is installed, toner life cannot be reliably indicated.
- The information about Tray 2 appears only when it is installed.

Counter Tab

Page Counter

Item	Description
Printer	Shows the following for pages printed using the printer function: <ul style="list-style-type: none"> • Total number of pages printed using the printer function, and lists/reports printed from the [List/Test Print] menu under [Printer Settings] • Number of color pages • Number of black-and-white pages printed using the printer function
Scanner	Shows the following for pages scanned using the scanner function: <ul style="list-style-type: none"> • Total number of pages • Number of color pages • Number of black-and-white pages
Copier	Shows the following for pages printed using the copier function: <ul style="list-style-type: none"> • Total number of pages • Number of color pages • Number of black-and-white pages

Item	Description
Fax	Shows the following for telephone line faxes: <ul style="list-style-type: none"> • Total number of pages sent and received • Number of pages sent • Number of pages received

Machine Counter

Item	Description
Machine Counter	Shows the following for pages printed using the printer, copier, and fax functions, and lists/reports: <ul style="list-style-type: none"> • Total number of pages • Number of color pages • Number of black-and-white pages
Black	Shows the following for pages printed using the printer, copier, and fax functions, and lists/reports: <ul style="list-style-type: none"> • Accumulated value of black toner A4 page coverage (in percent) • Accumulated value of black toner consumption (converted into fully-covered A4 pages)
Cyan	Shows the following for pages printed using the printer, copier, and fax functions, and lists/reports: <ul style="list-style-type: none"> • Accumulated value of cyan toner A4 page coverage (in percent) • Accumulated value of cyan toner consumption (converted into fully-covered A4 pages)
Magenta	Shows the following for pages printed using the printer, copier, and fax functions, and lists/reports: <ul style="list-style-type: none"> • Accumulated value of magenta toner A4 page coverage (in percent) • Accumulated value of magenta toner consumption (converted into fully-covered A4 pages)
Yellow	Shows the following for pages printed using the printer, copier, and fax functions, and lists/reports: <ul style="list-style-type: none"> • Accumulated value of yellow toner A4 page coverage (in percent) • Accumulated value of yellow toner consumption (converted into fully-covered A4 pages)

Economy Color Prints

Item	Description
Economy Color Prints (Color)	Shows the number of pages printed in Economy Color Printing mode using the printer function.
Black	Shows the following for pages printed in Economy Color Printing mode using the printer function: <ul style="list-style-type: none"> • Accumulated value of black toner A4 page coverage (in percent) • Accumulated value of black toner consumption (converted into fully-covered A4 pages)
Cyan	Shows the following for pages printed in Economy Color Printing mode using the printer function: <ul style="list-style-type: none"> • Accumulated value of cyan toner A4 page coverage (in percent) • Accumulated value of cyan toner consumption (converted into fully-covered A4 pages)
Magenta	Shows the following for pages printed in Economy Color Printing mode using the printer function: <ul style="list-style-type: none"> • Accumulated value of magenta toner A4 page coverage (in percent) • Accumulated value of magenta toner consumption (converted into fully-covered A4 pages)
Yellow	Shows the following for pages printed in Economy Color Printing mode using the printer function: <ul style="list-style-type: none"> • Accumulated value of yellow toner A4 page coverage (in percent) • Accumulated value of yellow toner consumption (converted into fully-covered A4 pages)

Duplex

Item	Description
Duplex Total Page	Shows the total number of sheets printed on both sides.

Note

- A sheet printed on both sides counts as two printed pages.

Machine Information Tab

Machine Information

Item	Description
Firmware Version	Shows the version of firmware installed on the machine.
Engine FW Version	Shows the version of firmware for the machine engine.
PCL Version	Shows the version of the PCL interpreter.
PS Version	Shows the version of the PS interpreter.
Machine ID	Shows the identification number of the machine.
Fax Card	Shows that a fax card is installed.
Total Memory	Shows the total memory installed on the machine.

Configuring the System Settings

Click [System Settings] to display the page for configuring the system settings.

This page contains the following tabs: [Sound Volume Adjustment], [Tray Paper Settings], [Copier], [Fax], [Priority Tray], [Toner Saving], [I/O Timeout], and [B&W Print Priority].

Sound Volume Adjustment Tab

Sound Volume Adjustment

Item	Description
Panel Key Sound	Select the volume of the beep that sounds when a key is pressed from [Off], [Low], [Middle], or [High].
Ring Volume	Select the volume of the ring when a call is received from [Off], [Low], [Middle], or [High].
On Hook Mode	Select the volume of the sound from the speaker during on hook mode from [Off], [Low], [Middle], or [High].
Job End Tone	Select the volume of the beep that sounds when a job is complete from [Off], [Low], [Middle], or [High].
Job Error Tone	Select the volume of the beep that sounds when a fax transmission error occurs from [Off], [Low], [Middle], or [High].
Alarm Volume	Select the volume of the alarm that sounds when an operation error occurs from [Off], [Low], [Middle], or [High].

Tray Paper Settings Tab

Tray 1

Item	Description
Paper Size	Select the paper size for Tray 1 from the following: A4, A5, A5 (210 × 148 mm), A6, B5 JIS, B6 JIS, 8 ¹ / ₂ × 14, 8 ¹ / ₂ × 13, 8 ¹ / ₂ × 11, 8 ¹ / ₄ × 13, 8 × 13, 5 ¹ / ₂ × 8 ¹ / ₂ , 7 ¹ / ₄ × 10 ¹ / ₂ , 8 ¹ / ₂ × 13 ² / ₅ , 8 ¹ / ₂ × 13 ³ / ₅ , 4 ¹ / ₈ × 9 ¹ / ₂ , 3 ⁷ / ₈ × 7 ¹ / ₂ , C5 Env, C6 Env, DL Env, 16K, Custom Size

Item	Description
Paper Type	Select the paper type for Tray 1 from the following: Thin Paper (60-65g/m ²), Plain Paper 1 (66-74g/m ²), Plain Paper 2 (75-81g/m ²), Middle Thick (82-90g/m ²), Thick Paper 1 (91-105g/m ²), Thick Paper 2 (106-163g/m ²), Recycled Paper, Color Paper, Prepunched Paper, Letterhead, Bond Paper, Preprinted Paper, Cardstock, Label Paper, Envelope

Tray 2

Item	Description
Paper Size	Select the paper size for Tray 2 from the following: A4, 8 ¹ / ₂ × 11
Paper Type	Select the paper type for Tray 2 from the following: Thin Paper (60-65g/m ²), Plain Paper 1 (66-74g/m ²), Plain Paper 2 (75-81g/m ²), Middle Thick (82-90g/m ²), Thick Paper 1 (91-105g/m ²), Recycled Paper, Color Paper, Letterhead, Preprinted Paper, Prepunched Paper

Bypass Tray

Item	Description
Paper Size	Select the paper size for the bypass tray from the following: A4, A5, A5 (210 × 148 mm), A6, B5 JIS, B6 JIS, 8 ¹ / ₂ × 14, 8 ¹ / ₂ × 13, 8 ¹ / ₂ × 11, 8 ¹ / ₄ × 13, 8 × 13, 5 ¹ / ₂ × 8 ¹ / ₂ , 7 ¹ / ₄ × 10 ¹ / ₂ , 8 ¹ / ₂ × 13 ² / ₅ , 8 ¹ / ₂ × 13 ³ / ₅ , 4 ¹ / ₈ × 9 ¹ / ₂ , 3 ⁷ / ₈ × 7 ¹ / ₂ , C5 Env, C6 Env, DL Env, 16K, Custom Size
Paper Type	Select the paper type for the bypass tray from the following: Thin Paper (60-65g/m ²), Plain Paper 1 (66-74g/m ²), Plain Paper 2 (75-81g/m ²), Middle Thick (82-90g/m ²), Thick Paper 1 (91-105g/m ²), Thick Paper 2 (106-163g/m ²), Recycled Paper, Color Paper, Prepunched Paper, Letterhead, Bond Paper, Cardstock, Label Paper, Envelope

Tray 1 Priority

Item	Description
Tray 1 Priority	<p>Select how print jobs using the Tray 1 are handled.</p> <ul style="list-style-type: none"><li data-bbox="454 397 642 427">• System Settings The paper settings configured on the machine's control panel are applied to all print jobs. An error occurs when the paper settings specified by the printer driver or the print command do not match the machine's settings.<li data-bbox="454 597 669 627">• Driver/Command When executing a print job specifying the paper tray, the paper settings specified in the printer driver or in the print command are applied regardless of the machine's settings.

Bypass Tray Setting Priority

Item	Description
Bypass Tray Setting Priority	<p>Select how print jobs using the bypass tray are handled.</p> <ul style="list-style-type: none"> • System Settings The paper settings configured on the machine's control panel are applied to all print jobs. An error occurs when the paper settings specified by the printer driver or the print command do not match the machine's settings. • Driver/Command When executing a print job specifying the paper tray, the paper settings specified in the printer driver or in the print command are applied regardless of the machine's settings. • Any Size/Type Printing proceeds even if the paper size/type settings of the machine and printer driver do not match, but if the paper is too small for the print job, the printed image will be cropped. • Any Custom Size/Type The machine prints custom size print jobs according to the printer driver's settings and prints standard size print jobs according to the machine's settings. For custom size print jobs, printing proceeds even if the paper size/type settings of the machine and printer driver do not match, but if the paper is too small for the print job, the printed image will be cropped. For standard size print jobs, an error will occur if the paper size/type settings of the machine and printer driver do not match.

Note

- The information about Tray 2 appears only when it is installed.

Copier Tab

Select Paper

Item	Description
Select Paper	<p>Select the paper size used for printing copies from the following: [Tray 1], [Tray 2], [Bypass Tray], [A4], or [8¹/₂ × 11].</p> <p>When a tray is selected, the machine prints from that tray only. When a paper size is selected, the machine checks the trays for the paper of the specified size in the order of priority as set in [Copier] in the [Priority Tray] page.</p> <p>If multiple trays contain valid paper, the first tray the machine finds will be used for printing; when that tray runs out of paper, the machine automatically switches to the next tray to continue printing.</p>

Note

- The information about Tray 2 appears only when it is installed.

Fax Tab

Select Paper Tray

Item	Description
Select Paper Tray	<p>Select the tray for printing faxes from the following: [Auto], [Tray 1], or [Tray 2].</p> <p>If [Auto] is selected, the machine uses Tray 1 and Tray 2 if they contain paper of the same size. In this case, the machine starts to print from the tray specified as the priority tray for [Fax] in the [Priority Tray] page. If that tray runs out of paper, the machine automatically switches to the other tray to continue printing.</p> <p>Only A4, Letter, or Legal size paper can be used for printing faxes. Make sure to select a tray that contains paper of the valid size.</p> <p>If Tray 2 is not installed, only [Tray 1] appears.</p>

Fax Number Confirmation

Item	Description
Fax Number Confirmation	<p>Enable this setting to configure the machine to require a fax number to be entered twice when specifying a destination manually.</p> <p>This setting appears only when the administrator password is set in the [Administrator] page.</p>

Fax Received File Processing

Item	Description
Received File Processing	Select whether received faxes are stored into the machine's memory for printing or forwarded to a destination specified for [Forwarding Destination].
Print Automatically	Select whether the faxes received into the machine's memory are printed automatically or stored for later manual printing.
Print Forwarded File	Select whether the forwarded faxes are printed or not.
Notify Forward Status	<p>Select whether e-mail notifications are sent after forwarding faxes or not. Email notification destination depends on how [Forwarding Destination] is specified:</p> <ul style="list-style-type: none"> • If specified with [E-mail Address]: the notification will be sent to the administrator e-mail address specified in [Administrator E-mail Address] in the [Administrator] page. • If specified with [Scan Destination]: the notification will be sent to the notification destination specified for the selected scan destination. <p>Note that if a destination e-mail address is not specified, no notification will be sent even if this setting is enabled.</p>
Forwarding Destination	<p>Specifies the forwarding destination.</p> <ul style="list-style-type: none"> • [E-mail Address]: Enter a destination e-mail address. Can contain up to 64 characters. • [Scan Destination]: Select a scan destination as a forwarding destination.
Number of Trials of Forwarding (time)	Specifies how many times the machine attempts to forward a fax (1 to 255 times).
Interval of Forwarding Trial (min.)	Specifies how many minutes the machine waits between forwarding attempts (1 to 255 minutes).

Authorized Reception

Item	Description
Authorized Reception	Enable this setting to set the machine to receive (or reject) faxes only from the programmed Special Senders. This helps you screen out unwanted documents, such as junk faxes, and prevents the wasting of fax paper. Special Senders can be programmed in the [Special Sender] page.
Receive Conditions	Specifies whether to receive or reject faxes from the programmed Special Senders. <ul style="list-style-type: none"> • Special Sender Receive faxes from the Special Senders and reject faxes from all other senders. • Other Than Special Sender Reject faxes from the Special Senders and receive faxes from all other senders.

2 Sided Print

Item	Description
2 Sided Print	Specify whether to print received faxes on both sides of paper.

8

Note

- [Fax Received File Processing] appears only for M C250FW.
- The information about Tray 2 appears only when it is installed.

Priority Tray Tab**Priority Tray**

Item	Description
Printer	Select the tray that the machine checks first for paper that can be used for the job from [Tray 1] or [Tray 2]. If automatic tray selection is specified for the print job and multiple trays contain valid paper, the first tray the machine finds will be used for printing; when that tray runs out of paper, the machine automatically switches to the next tray to continue printing.

Item	Description
Copier	<p>Select the tray that the machine checks first for paper that can be used for the job from [Tray 1] or [Tray 2].</p> <p>If [A4] or [8¹/₂ × 11] is selected for [Select Paper] in the [Copier] page and multiple trays contain valid paper, the first tray the machine finds will be used for printing; when that tray runs out of paper, the machine automatically switches to the next tray to continue printing.</p>
Fax	<p>Select the tray that the machine uses first for printing out faxes from [Tray 1] or [Tray 2].</p> <p>If [Auto] is selected for [Select Paper Tray] in the [Fax] page and both Tray 1 and Tray 2 contain paper of the same size, the machine starts to print from the specified tray. If that tray runs out of paper, the machine automatically switches to the other tray to continue printing.</p>

 **Note**

- The information about Tray 2 appears only when it is installed.

Toner Saving Tab

Toner Saving

Item	Description
Toner Saving	Enable this setting to print using a reduced amount of toner when printing out copies.

I/O Timeout Tab

I/O Timeout

Item	Description
Fixed USB Port	<p>Specifies whether the same printer/LAN-Fax driver can be used for multiple machines or not under USB connection.</p> <p>If this setting is enabled, the same printer/LAN-Fax driver you have installed in your computer can be used with any machine other than the one originally used for installation, if the machine is of the same model.</p> <p>If disabled, you must install the printer/LAN-Fax driver separately for individual machines, because the machine other than the original will be recognized as a new device upon USB connection.</p>
NFC	<p>Specifies whether or not to synchronize the data you have configured using the control panel and Web Image Monitor with the data stored in NFC.</p> <p>You can read and write the data in NFC by using the application corresponding to the machine.</p>
Locked Print Timeout (seconds)	<p>Specifies how many seconds the machine holds a new Locked Print file, when the machine cannot store any more Locked Print files (0 to 300 seconds). Within this time, you can print or delete the new Locked Print file.</p> <p>You can also print or delete an existing Locked Print file so that the new Locked Print file can be stored in the machine.</p>

↓ Note

- [Locked Print Timeout (seconds)] appears only for M C250FW.

Black-and-White Print Priority Tab

B&W Print Priority

Item	Description
B&W Print Priority	<p>Enable this setting to suppress the consumption of color toner when printing black-and-white pages. Also, amount of color toner consumed during warm-up time for maintenance will also be lowered.</p>

Registering Destinations

Scan and fax destinations can be registered using Web Image Monitor.

Up to 100 scan destinations and 200 fax destinations (20 Quick Dial and 200 Speed Dial destinations) can be registered. See the scan and fax sections for more information on registering destinations.

Note

- For details about registering scan destinations, see page 126 "Registering Scan Destinations".
- For details about registering fax destinations using Web Image Monitor, see page 176 "Registering Fax Destinations".

Registering Fax Special Senders

Fax Special Senders can be registered using Web Image Monitor.

Up to 30 Special Senders be registered. For details about registering Special Senders, see page 202 "Receiving a Fax".

Restricting Machine Functions According to User

You can configure settings to require a user code when someone tries to use certain machine functions. To enable this setting, you must first configure the machine settings via Web Image Monitor.

★ Important

- To print jobs that require authentication you can use only the PCL printer driver. Printing such jobs from the PostScript 3 printer driver is not possible.

↓ Note

- For details about using Web Image Monitor, see page 268 "Using Web Image Monitor".

Enabling the User Restriction Settings

This section explains how to configure settings to permit only authorized users to use certain machine functions.

Using Web Image Monitor, enable user restriction for all or some of the functions listed below, and then register users who can use those functions.

- Copying (both color and black-and-white)
- Color copying
- Sending faxes
- Scan to E-mail/FTP/Folder
- Scan to USB
- Printing (both color and black-and-white)
- Color printing
- Sending faxes via LAN-Fax

You can specify functions available to each user upon authentication. Up to 30 users can be registered.

1. Start the Web browser, and access the machine by entering its IP address.
2. Click [Restrict Available Functions].
3. Enter the administrator password if required.
4. Click [Apply].

- Under "Available Functions", select [Restrict] for the functions you want to restrict, and then click [Apply].

Restrict Available Functions

Available Functions Available Functions per User

- Copying : Restrict Do not Restrict
- Color Copying : Restrict Do not Restrict
- Fax Transmitting : Restrict Do not Restrict
- Scanner Sending : Restrict Do not Restrict
- Scanner Sending (USB) : Restrict Do not Restrict
- Printing : Restrict Do not Restrict
- Color Printing : Restrict Do not Restrict
- PC Fax Transmitting : Restrict Do not Restrict

Apply Cancel

Select [Do not Restrict] for the functions you do not want to restrict.

The user restriction setting is enabled for the selected function. Proceed to the following steps to register users.

- Click [Available Functions per User].

A list of currently registered user entries appears.

Restrict Available Functions

Available Functions Available Functions per User

Change Delete

No.	User Name	Pictbridge	Printing	Color Printing
01				
02				
03				
04				
05				
06				
07				
08				
09				
10				
11				

- Select a user entry, and then click [Change].

The following window appears.

Available Functions

- No. : 1
- User Name :
- User Code :

Available Functions :

- Copying
- Color Copying
- Fax Transmitting
- Scanner Sending
- Scanner Sending (USB)
- Printing
- Color Printing
- PC Fax Transmitting

Apply Cancel

8. Enter the user name in [User Name] using up to 16 alphanumeric characters.

9. Enter the user code in [User Code] using up to 8 digits.

The user code will be used to authenticate users when they try to use a restricted function.

10. Select the functions you want to make available to the user upon authentication.

Unselected functions will be unavailable to users authenticated under this user code.

11. Click [Apply].

12. Close the Web browser.

Note

- You must enter both the user name and user code to register a user entry.
- Make sure that different user entries do not share the same user name or user code.

Modifying user entries

This section explains how to modify user entries.

1. Start the Web browser, and access the machine by entering its IP address.

2. Click [Restrict Available Functions].

3. Enter the administrator password if required.

4. Click [Apply].

5. Click [Available Functions per User].

A list of currently registered user entries appears.

6. Select the entry to modify, and then click [Change].

7. Modify settings as necessary.

8. Click [Apply].

9. Close the Web browser.

Deleting user entries

This section explains how to delete user entries.

1. Start the Web browser, and access the machine by entering its IP address.

2. Click [Restrict Available Functions].

3. Enter the administrator password if required.

4. Click [Apply].

5. Click [Available Functions per User].

A list of currently registered user entries appears.

6. Select the entry to delete, and then click [Delete].
7. Confirm that the entry you have selected is the entry that you want to delete.
8. Click [Apply].
9. Close the Web browser.

When Machine Functions are Restricted

Restricted functions can be used only by authorized users.

Depending on the restricted function, users will be authenticated from the machine's control panel or in the printer/LAN-Fax driver.

★ Important

- To print jobs that require authentication you can use only the PCL printer driver. Printing such jobs from the PostScript 3 printer driver is not possible.
- The procedure in this section is an example based on Windows 10.

The table below shows the functions that can be restricted, and how users can be authenticated to use them.

Restricted Function	Authentication method
<ul style="list-style-type: none"> • Copying (both color and black-and-white) • Color copying • Sending faxes • Scan to E-mail/FTP/Folder • Scan to USB 	<p>The machine requests for a user code when a user presses the [B&W Start] or [Color Start] key.</p> <p>The user must enter a valid user code from the control panel.</p>
<ul style="list-style-type: none"> • Printing (both color and black-and-white) • Color printing • Sending faxes via LAN-Fax 	<p>The user must enter a valid user code in the printer or LAN-Fax driver before executing a print command.</p>

Authentication using the control panel

1. If the machine requests for the user code, press the box, enter a user code, and then press [OK].

If you enter a wrong user code 3 times, the machine beeps and denies further attempts of authentication.

2. If the printer requests for a user code, enter a user code.

If you enter a wrong user code, the printer denies further attempts of authentication.

3. Press [OK].

Authentication using the printer or LAN-Fax driver

1. Open the file you want to print on your computer.

2. On the [File] menu, click [Print...].
3. In the [Select Printer] area, select the name of this machine, and then click [Preferences].
4. Click the [Valid Access] tab or check the [User Code] check box.
5. Enter the user code using 1 to 8 digits, and then click [OK].
6. Execute a print command.

If an incorrect user code is entered, the job will be canceled automatically (without any error message).

Configuring the Network Settings

Click [Network Settings] to display the page for configuring the network settings.

This page contains the following tabs: [Network Status], [IPv6 Configuration], [Network Application], [DNS], [Auto E-mail Notification], [SNMP], [SMTP], [POP3], [Internet Fax], [Wireless], and [Certificate].

★ Important

- Depending on the settings you change, the machine might need to be restarted.
- Depending on the model you are using, some items might not appear.

Network Status Tab

General Status

Item	Description
Ethernet Speed	Shows the type and speed of the network connection.
IPP Printer Name	Shows the name used to identify the machine on the network.
Network Version	Shows the version of the machine's network module (a part of the machine firmware).
Ethernet MAC Address	Shows the Ethernet MAC address of the machine.
Active Interface	Shows the active communication method.
Wi-Fi Direct IP Address	Shows the IP address of Wi-Fi Direct.

TCP/IP Status

Item	Description
DHCP	Select whether the machine should receive a dynamic IPv4 address automatically using DHCP. To use DHCP, select [Active]. When enabled, the items below cannot be configured.
IP Address	Enter the IPv4 address for the machine.
Subnet Mask	Enter the subnet mask of the network.
Gateway	Enter the IPv4 address of the network gateway.

IPv6 Configuration Tab

IPv6

Item	Description
IPv6	<p>Select whether to enable or disable IPv6. You cannot disable IPv6 using Web Image Monitor if the machine is currently in use in an IPv6 environment. In this case, use the control panel to disable [IPv6] under network settings.</p> <p>When disabled, [DHCP], [Manual Configuration Address], [Prefix Length], and [Gateway Address] below cannot be configured.</p>

IPv6 Address

Item	Description
DHCP	Select whether or not the machine obtains its IPv6 address from a DHCP server.
IP Address (DHCP)	Displays the IPv6 address obtained from the DHCP server when [DHCP] is set to [Active].
Stateless Address	Displays up to four stateless auto addresses.
Gateway Address	Displays the machine's default gateway address.
Link-local Address	Displays the link local address of the machine. The link local address is an address that is valid only inside the local network (local segment).
Manual Configuration Address	Enter the machine's IPv6 address. Can contain up to 39 characters.
Prefix Length	Enter the prefix length, using a value between 0 and 128.
Gateway Address	Enter the default gateway's IPv6 address. Can contain up to 39 characters.

Network Application Tab

Scanner Send Setting

Item	Description
E-mail	Select to enable the Scan to E-mail feature.

Item	Description
Max. E-mail Size	Select the maximum size of scan files that can be attached to an e-mail message (1 to 5 MB, or no limit).
FTP	Select to enable the Scan to FTP feature.
Folder	Select to enable the Scan to Folder feature.

Network Print Setting

Item	Description
IPP	Select to enable network printing using Internet Print Protocol (via TCP port 631/80).
FTP	Select to enable network printing using an embedded FTP server in the machine (via TCP port 20/21).
RAW	Select to enable network raw printing.
Port No.	Enter the TCP port number to use for raw printing. The valid range is 1024 to 65535, except 53550 and 49999 (default is 9100).
LPR	Select to enable network printing using LPR/LPD (via TCP port 515).

mDNS Setting

Item	Description
mDNS	Select to enable Multicast DNS (via UDP port 5353). If disabled, the item below cannot be configured.
Printer Name	Enter the name of the machine. Can contain up to 32 characters.

DNS Tab

DNS

Item	Description
DNS Method	Select whether to specify domain name servers manually or receive DNS information from the network automatically. When set to [Auto-Obtain (DHCP)], [Primary DNS Server], [Secondary DNS Server], and [Domain Name] below become unavailable.
Primary DNS Server	Enter the IPv4 address of the primary DNS.

Item	Description
Secondary DNS Server	Enter the IPv4 address of the secondary DNS.
Domain Name	Enter the IPv4 domain name for the machine. Can contain up to 32 characters.
IPv6 DNS Method	Select whether to specify the domain server manually or have the machine obtain its DNS information automatically. When set to [Auto-Obtain (DHCP)], [Primary IPv6 DNS Server], [Secondary IPv6 DNS Server], and [IPv6 Domain Name] below become unavailable.
Primary IPv6 DNS Server	Enter the IPv6 address of the primary IPv6 DNS server. Can contain up to 39 characters.
Secondary IPv6 DNS Server	Enter the IPv6 address of the secondary IPv6 DNS server. Can contain up to 39 characters.
IPv6 Domain Name	Enter the IPv6 domain name of the machine. Can contain up to 32 characters.
DNS Resolve Priority	Select whether to give priority to IPv4 or IPv6 for DNS name resolution.
DNS Timeout (seconds)	Enter the number of seconds the machine waits before considering a DNS request to have timed out (1 to 999 seconds).
Host Name	Enter a host name for the machine. Can contain up to 15 characters.

Auto E-mail Notification Tab

E-mail Notification 1/E-mail Notification 2

Item	Description
Display Name	Enter a sender name for notification e-mail. Can contain up to 32 characters.
E-mail Address	Enter the address of the recipient of the alert email. Can contain up to 64 characters.
Paper Misfeed	Select to send an alert e-mail to the specified address if a paper jam occurs.
Out of Paper	Select to send an alert e-mail to the specified address if paper runs out.
Toner Almost Empty	Select to send an alert e-mail to the specified address if toner becomes low.

Item	Description
Call Service	Select to send an alert e-mail to the specified address if the machine requires servicing.
Out of Toner	Select to send an alert e-mail to the specified address if toner runs out.
Cover Open	Select to send an alert e-mail to the specified address if a cover is open.

SNMP Tab

SNMP

Item	Description
SNMP	Select whether to enable the machine to use SNMP services.

Trap

Item	Description
Target Trap	Select whether to enable the machine to send traps to the management host (NMS). When disabled, [SNMP Management Host 1] and [SNMP Management Host 2] below become unavailable.
SNMP Management Host 1	Enter the IP address or host name of a management host. Can contain up to 64 characters.
SNMP Management Host 2	Enter the IP address or host name of a management host. Can contain up to 64 characters.

Community

Item	Description
Get Community	Enter the community name to use for authentication of Get requests. Can contain up to 32 characters.
Trap Community	Enter the community name to use for authentication of Trap requests. Can contain up to 32 characters.

System

Item	Description
Location	Enter the location of the machine. The location entered here is displayed on the main page. Can contain up to 64 characters.
Contact	Enter the contact information of the machine. The contact information entered here is displayed on the main page. Can contain up to 64 characters.

SMTP Tab**SMTP**

Item	Description
Primary SMTP Server	Enter the IP address or host name of the SMTP/POP3 server. Can contain up to 64 characters.
Port No.	Enter the port number for SMTP (1 to 65535).
Authentication Method	Select an authentication method from the following: [Anonymous]: The user name and password are not necessary. [SMTP]: The machine supports NTLM and LOGIN authentication. [POP before SMTP]: The POP3 server is used for authentication. When sending e-mails to an SMTP server, you can enhance the SMTP server security level by connecting to the POP server for authentication.
User Name	Enter the user name for logging in to the SMTP server. Can contain up to 32 characters.
Password	Enter the password for logging in to the SMTP server. Can contain up to 32 characters.
Device E-mail Address	Enter the machine's e-mail address. This address is used as the sender's address of e-mail messages sent from this machine, such as notification e-mails. Can contain up to 64 characters.
Server Timeout (seconds)	Enter the number of seconds the machine waits before considering an SMTP operation to have timed out (1 to 999).

Item	Description
Time Zone	Select a time zone according to your geographic location. Selecting a different time zone may cause transmission date and time to be incorrect for email sent by the Scan to E-mail function, even when the machine's clock is set correctly.

POP3 Tab

POP3 Settings

Item	Description
POP3 Server	Enter the IP address or host name of the POP3 server for e-mail reception. The POP3 server specified here will be used for [POP before SMTP]. Can contain up to 64 characters.
User Account	Enter the user name for logging in to the POP3 server. Can contain up to 32 characters.
User Password	Enter the password for logging in to the POP3 server. Can contain up to 32 characters.
Authentication	Select an authentication method from the following: [None]: Password will not be encrypted. [APOP Authentication]: Password will be encrypted. [Auto]: Password will be encrypted or not encrypted according to the POP3 server's settings.

Internet Fax Tab

Item	Description
Internet Fax Transmission	Select whether to enable or disable the Internet Fax function.
Error Notification E-mail	Select whether to send a notification e-mail to the sender of the Internet Fax or not when e-mail reception fails. The text will include the machine's host name (as set in the DNS settings page), model name, and contact e-mail address (as set in the administrator settings page).

Item	Description
Insert System-fixed Text	Select whether to include system-fixed text in the body of the e-mail or not when sending Internet Faxes. The text will include the machine's host name (as set in the DNS settings page), model name, and contact e-mail address (as set in the administrator settings page).
Automatic POP	Select whether to automatically connect to the POP3 server to check for new e-mails or not. If this setting is enabled, the connection will be made at an interval specified in [POP Interval (minutes)].
POP Server: E-mail Reception Setting	Select whether to leave or delete e-mails in the POP3 server after receiving them. [No]: Delete e-mails from the server after receiving them. [Save E-mail]: Leave e-mails on the server after receiving them. [Save Only Error Info]: Delete e-mails that are successfully received from the server only.
POP Interval (minutes)	Specifies how many minutes the machine waits between automatic connections to the POP3 server to acquire new e-mails (2 to 1440 minutes).

Note

- [Internet Fax] appears only for M C250FW.

Wireless Tab

Wireless LAN Status

Item	Description
Wireless LAN Status	Displays the status of the connection to the wireless LAN.
MAC Address	Displays the MAC address.
Communication Mode	Displays the communication mode that the machine is connecting in.
SSID	Displays the SSID of the access point that the machine is connected to.
Wireless Signal Status	Displays the strength of the wireless signal that is being received.
Wireless	Specifies whether or not to use the wireless LAN.

Wireless LAN Settings

Item	Description
SSID	Enter the SSID of the access point. The SSID can contain up to 32 characters. When you click [Scan List], a list of available access points is displayed. You can select the SSID from the list.
Communication Mode	[Infrastructure] is selected by default. Therefore, connect the machine to a wireless router or access point.
Authentication	Select an authentication method.
Encryption	Select an encryption method.
WPA Passphrase	If [WPA2-PSK] or [Mixed Mode WPA/WPA2] is selected for [Authentication], enter the WPA encryption key.
WEP Key Length	If [WEP] is selected for [Encryption], select 64 bits or 128 bits for the length of the encryption key.
WEP Transmit Key ID	Select an ID number to identify each WEP key in case multiple WEP connections are configured.
WEP Key Format	Select a format for entering the WEP key.
WEP Key	Enter the WEP key. The number and type of characters you can enter vary depending on the length and format selected for the key. See the following: <ul style="list-style-type: none"> • WEP key length: [64bit], Format: [Hexadecimal] WEP key max length: 10 characters (0-9, A-F, a-f) • WEP key length: [64bit], Format: [ASCII] WEP key max length: 5 characters (0x20-0x7e) • WEP key length: [128bit], Format: [Hexadecimal] WEP key max length: 26 characters (0-9, A-F, a-f) • WEP key length: [128bit], Format: [ASCII] WEP key max length: 13 characters (0x20-0x7e)

↓ Note

- If you are configuring the connection settings manually, check the SSID, authentication method, or encryption key of the access point or wireless router in advance.

Wi-Fi Direct Settings

Item	Description
Wi-Fi Direct Type	Select 2.4 GHz or 5 GHz as the wireless LAN frequency.
SSID	Enter the SSID name. The SSID can contain up to 32 characters.
WPA Passphrase	Enter the passphrase for Wi-Fi Direct connection. You can enter 8 to 32 characters for a passphrase.

Certificate Tab

You can use the following two types of certificates on this machine:

- Certificates created by the machine.
- Certificates issued by certification authorities.

You can install only one certificate on the machine.

If you execute [Create New Self-Signed Certificate], [Create Certificate Request], [Install Certificate], or [Import Certificate and Private Key], the existing certificate on the machine is deleted.

Follow the procedure below to set items:

1. Check the item you want to set.
2. Enter the password if required.
3. Click [Next].

Certificate

Item	Description
Create New Self-Signed Certificate	Select this item to create a new self-signed certificate.
Create Certificate Request	Select this item to request the certification authority to issue a new certificate. You can submit a certificate created using this setting to the certification authority. Note that you cannot submit a certificate to the certification authority directly via Web Image Monitor.
Install Certificate	Select this item to install the certificate issued by the certification authority.

Item	Description
Import Certificate and Private Key	Select this item to install the certificate created by the machine. You can use certificates that are in the following formats: <ul style="list-style-type: none">• PEM• PKCS12
Export Certificate	Select this item to back-up the certificate installed on the machine. The certificate is exported in PKCS12 format.
View Certificate	Select this item to check details about the certificate that is installed on the machine.

Configuring the IPsec Settings

Click [IPsec Settings] to display the page for configuring the IPsec settings.

This page contains the following tabs: [IPsec Global Settings] and [IPsec Policy List].

★ Important

- This function is available only when an administrator password is specified.

IPsec Global Settings Tab

Item	Description
IPsec Function	Select whether to enable or disable IPsec.
Default Policy	Select whether to allow for the default IPsec policy.
Broadcast and Multicast Bypass	Select the services that you do not want to apply IPsec from the following: [DHCPv4], [DHCPv6], [SNMP], [mDNS], [NetBIOS], [UDP Port 53550]
All ICMP Bypass	Select whether to apply IPsec to ICMP packets (IPv4 and IPv6) from the following: [Active]: All ICMP packets will be bypassed without IPsec protection. "ping" command (echo request and echo reply) is not encapsulated by IPsec. [Inactive]: Some ICMP message types will be bypassed without IPsec protection.

IPsec Policy List Tab

Item	Description
No.	IPsec policy number.
Name	Displays the name of the IPsec policy.
Address Settings	Displays the IP address filter of the IPsec policy as below: Remote address/Prefix length
Action	Displays the action of the IPsec policy as "Allow", "Drop", or "Require Security".

Item	Description
Status	Displays the status of the IPsec policy as "Active" or "Inactive".

To configure IPsec policies, select the desired IPsec policy, and then click [Change] to open the "IPsec Policy Settings" page. The following settings can be made on the "IPsec Policy Settings" page.

IP Policy Settings

Item	Description
No.	Specify a number between 1 and 10 for the IPsec policy. The number you specify will determine the position of the policy in the IPsec Policy List. Policy searching is performed according to the order of the list. If the number you specify is already assigned to another policy, the policy you are configuring will take the number of the earlier policy, and the earlier policy and any subsequent policies will be renumbered accordingly.
Activity	Select whether to enable or disable the policy.
Name	Enter the name of the policy. Can contain up to 16 characters.
Address Type	Select IPv4 or IPv6 as the type of IP address to be used in IPsec communication.
Local Address	Displays the IP address of this printer.
Remote Address	Enter the IPv4 or IPv6 address of the device with which to communicate. Can contain up to 39 characters.
Prefix Length	Enter the prefix length of the Remote Address, using a value between 1 and 128. If this setting is left blank, "32" (IPv4) or "128" (IPv6) will be automatically selected.
Action	Specify how the IP packets are processed from the following: <ul style="list-style-type: none"> • [Allow]: IP packets are both sent and received without IPsec applied to them. • [Drop]: IP packets are discarded. • [Require Security]: IPsec is applied to IP packets that are both sent and received. <p>If you have selected [Require Security], you must configure [IPsec Settings] and [IKE Settings].</p>

IPsec Settings

Item	Description
Encapsulation Type	Specify the encapsulation type from the following: <ul style="list-style-type: none"> • [Transport]: Select this mode to secure only the payload section of each IP packet when communicating with IPsec compliant devices. • [Tunnel]: Select this mode to secure every section of each IP packet. We recommend this type for communication between security gateways (such as VPN devices).
Security Protocol	Select the security protocol from the following: <ul style="list-style-type: none"> • [AH]: Establishes secure communication that supports authentication only. • [ESP]: Establishes secure communication that supports both authentication and data encryption. • [ESP&AH]: Establishes secure communication that supports both data encryption and authentication of packets, including packet headers. Note that you cannot specify this protocol when [Tunnel] is selected for [Encapsulation Type].
Authentication Algorithm for AH	Specify the authentication algorithm to be applied when [AH] or [ESP&AH] is selected for [Security Protocol] from the following: [MD5], [SHA1]
Encryption Algorithm for ESP	Specify the encryption algorithm to be applied when [ESP] or [ESP&AH] is selected for [Security Protocol] from the following: [None], [DES], [3DES], [AES-128], [AES-192], [AES-256]
Authentication Algorithm for ESP	Specify the authentication algorithm to be applied when [ESP] is selected for [Security Protocol] from the following: [MD5], [SHA1]
Life Time	Specify the life time of the IPsec SA (Security Association) as a time period or data volume. The SA will expire when the time period you specify elapses or the volume of data you specify reaches the volume carried. If you specify both a time period and a data volume, the SA will expire as soon as either is reached, and a new SA will then be obtained by negotiation. To specify the life time of the SA as a time period, enter a number of seconds. To specify the life time of the SA as a data volume, enter a number of KBs.

Item	Description
Key Perfect Forward Secrecy	Select whether to enable or disable PFS (Perfect Forward Secrecy).

IKE Settings

Item	Description
IKE Version	Displays the IKE version.
Encryption Algorithm	Specify the encryption algorithm from the following: [DES], [3DES], [AES-128], [AES-192], [AES-256]
Authentication Algorithm	Specify the authentication algorithm from the following: [MD5], [SHA1]
IKE Life Time	Specify the life time of the ISAKMP SA as a time period. Enter a number of seconds.
IKE Diffie-Hellman Group	Select the IKE Diffie-Hellman Group to be used in the generation of the IKE encryption key from the following: [DH1], [DH2]
Pre-Shared Key	Specify the PSK (Pre-Shared Key) to be used for authentication of a communicating device. Can contain up to 32 characters.
Key Perfect Forward Secrecy	Select whether to enable or disable PFS (Perfect Forward Secrecy).

Printing Lists/Reports

Click [Print List/Report] to display the page for printing reports. Then, select an item and click [Print] to print out information for that item.

Print List/Report

Item	Description
Configuration Page	Prints general information about the machine and its current configuration.
Fax Journal	Prints a fax transmission and reception journal for the last 50 jobs. For details about automatic fax journal printing, see page 224 "Fax Settings".
Fax TX/RX Standby File List	Prints a list of fax jobs remaining in the machine's memory to be printed, sent, or forwarded.
Quick Dial Destination List	Prints a list of Quick Dial entries.
Fax Speed Dial Destination List	Prints a list of Speed Dial entries.
Scanner Destination List	Prints a list of scan destinations.
Scanner Journal	Prints a scanner journal for the last 100 Scan to E-mail, Scan to FTP, and Scan to Folder transmissions.
Maintenance Page	Prints the maintenance page.

Note

- Reports cannot be printed via Web Image Monitor if other jobs are printing. Before printing reports, confirm that machine is not printing.
- Reports will be printed on A4 or Letter size paper. Load one of these sizes of paper into the tray before printing reports.

Configuring the Administrator Settings

Click [Administrator Tools] to display the page for configuring the administrator settings.

This page contains the following tabs: [Administrator], [Reset Settings], [Backup Setting], [Restore Setting], [Set Date/Time], and [Energy Saver Mode].

Administrator Tab

Administrator Settings

Item	Description
Change Password	Check this to configure the administrator password.
New Password	Enter the new administrator password. Can contain up to 16 characters.
Confirm New Password	Enter the same password again, to confirm.
Change E-mail Address	Check this to configure the administrator e-mail address.
Administrator E-mail Address	Enter the administrator e-mail address. If the machine's e-mail address is not configured in the [SMTP] page, this address will be used as the sender's address of e-mails sent from this machine, such as notification e-mails and Internet Faxes. Can contain up to 64 characters.

Note

- Administrator e-mail address can only be configured with M C250FW.

Reset Settings Tab

Reset Settings

Item	Description
Reset Network Settings	Select to restore settings configured under the [Network Settings] and [Administrator Tools].
Reset Menu Settings	Select to restore settings that are not related to the network to their defaults.
Clear Scan Destination	Select to clear the scan destinations.

Item	Description
Reset Settings of Available Functions	Select to clear the user restriction settings.
Clear Address Book	Select to clear the fax destinations.
Reset IPsec Settings	Select to clear the IPsec settings.

Note

- [Reset IPsec Settings] appears only when the administrator password is specified.

Backup Setting Tab

Important

- When sending the machine for repair, it is important that you create backup files in advance. The machine's settings are returned to the default after repair.

Backup Setting

Item	Description
Back up Network Settings	Backs up settings configured under the [Network Settings] and [Administrator Tools]. Note that, however, [Max. E-mail Size] setting under [Network Application] will not be backed up here; it will be backed up by [Back up Menu Settings] instead.
Back up Menu Settings	Backs up settings that are not related to the network.
Back up Scan Destination	Backs up scan destinations to a file.
Back up Settings of Available Functions	Backs up user restriction settings to a file.
Back up Address Book	Backs up fax destinations to a file.
Back up IPsec Settings	Backs up the IPsec settings to a file.

Follow the procedure below to create configuration backup files.

1. Select the radio button for the type of data you wish to back up.
2. Enter the administrator password if required.

3. Click [OK].
4. Click [Save] in the confirmation dialog box.
5. Navigate to the location to save the backup file.
6. Specify a name for the file, and click [Save].

↓ Note

- [Back up IPsec Settings] appears only when the administrator password is specified.

Restore Setting Tab

★ Important

- When the machine is returned from repair, it is important that you restore the machine's settings from the backup files. The machine's settings are returned to the default after repair.

Restore Setting

Item	Description
File to Restore	Enter the path and name of the file to restore, or click [Browse...] to select the file.

Follow the procedure below to restore configuration backup files.

1. Click [Browse...].
2. Navigate to the directory containing the backup file to restore.
3. Select the backup file, and click [Open].
4. Enter the administrator password if required.
5. Click [OK].

↓ Note

- If the settings are not restored successfully, an error message appears. Try again to restore the file completely.

Set Date/Time Tab

Set Date

Item	Description
Year	Enter the current year (2000 to 2099).
Month	Enter the current month (1 to 12).

Item	Description
Day	Enter the current day (1 to 31).
Date Format	Select the date format from [MM/DD/YYYY], [DD/MM/YYYY], or [YYYY/MM/DD].

Set Time

Item	Description
Time Format	Select 24- or 12-hour time format.
Time (AM/PM)	Select [AM] or [PM] if 12-hour time format is selected.
hour (0-23)	Enter the current hour if 24-hour time format is selected (0-23).
hour (1-12)	Enter the current hour if 12-hour time format is selected (1-12).
min. (0-59)	Enter the current minute (0-59).

Energy Saver Mode Tab**Energy Saver Mode**

Item	Description
Energy Saver Mode 1	Select [Active] to set the machine to enter Energy Saver mode 1 if the machine has been idle for about 30 seconds. It takes less time to recover from Energy Saver mode 1 than from power-off state or Energy Saver mode 2, but power consumption is higher in Energy Saver mode 1 than in Energy Saver mode 2.
Energy Saver Mode 2	Set the machine to enter Energy Saver mode 2 after the period of time specified for [Waiting Time (1 min. - 60 min.)] is passed (1 to 60 minutes). The machine consumes less power in Energy Saver mode 2 than in Energy Saver mode 1, but it takes longer to recover from Energy Saver mode 2 than from Energy Saver mode 1.

Note

- The machine recovers from Energy Saver mode when it receives a print job, prints a received fax, or when the [Copy], [Color Start], or [B&W Start] key is pressed.
- Regardless of the settings for Energy Saver mode 1 or Energy Saver mode 2, the machine enters Energy Saver mode 1 after being idle for 10 minutes.

9. Maintaining the Machine

This chapter describes how to replace supplies and how to clean the machine.

Replacing the Print Cartridge

★ Important

- Store print cartridge in a cool dark place.
- Actual printable numbers vary depending on image volume and density, number of pages printed at a time, paper type and size, and environmental conditions such as temperature and humidity. Toner quality degrades over time. Early replacement of the print cartridge might be necessary. Therefore, we recommend you always keep a new print cartridge ready.
- For good print quality, the manufacturer recommends that you use genuine toner from the manufacturer.
- The manufacturer shall not be responsible for any damage or expense that might result from the use of parts other than genuine parts from the manufacturer with your office products.
- If you try to print while the message "Replacement Required: Toner Cartridge (XX)" is being displayed, another message "Continue printing?" may appear. If this happens, you can print a few pages by pressing [Yes], although the print quality may be lower. Replace the toner as soon as possible. If the message "Continue printing?" does not appear, replace the toner immediately.
- Do not allow paper clips, staples, or other small objects to fall inside the machine.
- Do not expose the print cartridge without its cover to direct sunlight for a long time.
- Do not touch the print cartridge's photo conductor unit and the ID chip on the side of the print cartridge as indicated in the illustration below.

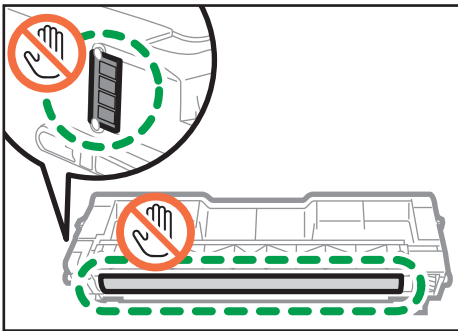

ECC072

- When removing print cartridges, be careful not to touch the laser scanning unit under the upper cover (the position shown by the arrow in the illustration below).

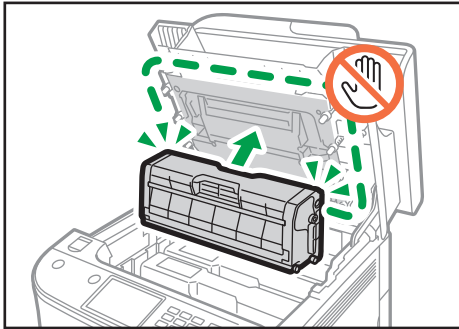

- If cyan, magenta, or yellow toner runs out, you can print in black and white using just the black toner. Change the color mode setting to Black and White using the machine's driver.
- If black toner runs out, you cannot print in black and white or color until the black print cartridge is replaced.

Messages on the screen

- Replace the indicated print cartridge when any of the following messages appear on the screen:
"Replacement Required: Toner Cartridge" (XX)
("XX" indicates the toner color)
- Prepare the indicated print cartridge when any of the following messages appear on the screen:
"Replace Required Soon: Toner Cartridge" (XX)
("XX" indicates the toner color)

9

1. Pull up the lever on the top cover, and then carefully raise the top cover.

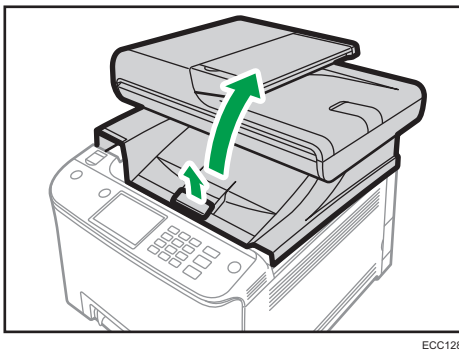

2. Carefully lift out the print cartridge vertically, holding its center.

From the rear, the print cartridges are installed in the order of cyan (C), magenta (M), yellow (Y), and black (K).

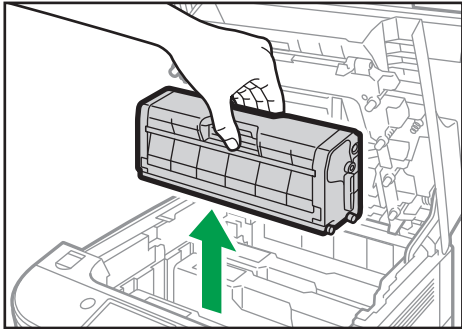

ECC167

- Do not shake the removed print cartridge. Doing so can cause remaining toner to leak.
- Place the old print cartridge on paper or similar material to avoid dirtying your workspace.
- The toner color is indicated by the label on each print cartridge.

3. Take the new print cartridge out of the box, and then take it out of the plastic bag.

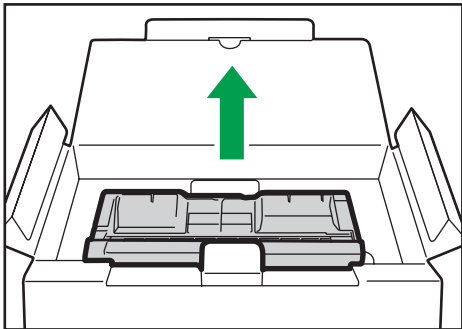

DUE260

4. Hold the print cartridge and shake it from side to side five or six times.

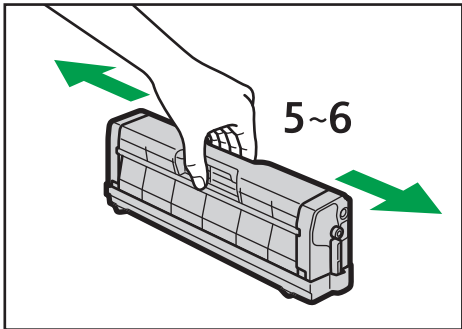

ECC130

Even distribution of toner within the bottle improves print quality.

5. Remove the protective cover from the print cartridge.

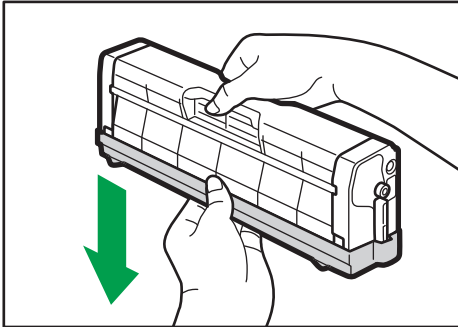

ECC131

6. Check the toner color and corresponding location, and then carefully insert the print cartridge vertically.

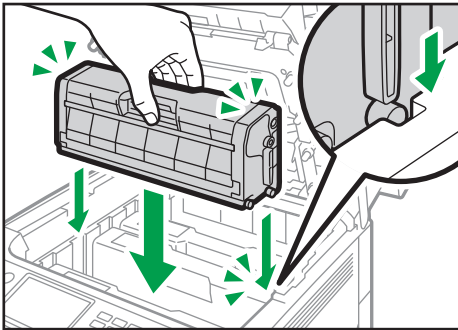

ECC132

7. Using both hands, hold the center of the top cover and close the cover carefully.

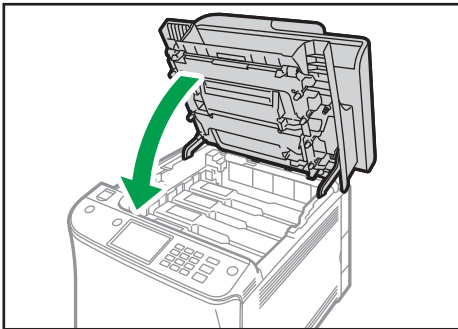

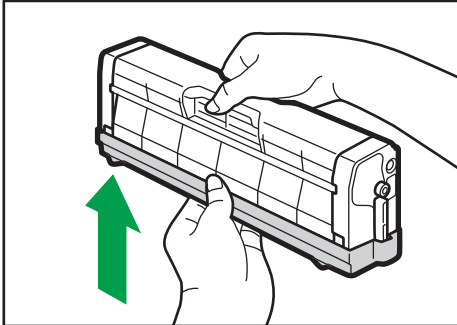

ECC133

8. Attach the protective cover you removed in Step 5 on the old print cartridge. Then, put the old print cartridge into the bag, and then put it into the box.



ECC134

Note

- Make sure to cover the old print cartridge with the protective cover for recycling and environmental purposes.
-  **Region A** (mainly Europe and Asia)
If you want to discard your used toner container, please contact your local sales office. If you discard it by yourself, treat it as general plastic waste material.
-  **Region B** (mainly North America)
Please see our local company website for information on the recycling of supply products, or you can recycle items according to the requirements of your local municipalities or private recyclers.

Replacing the Waste Toner Bottle

Messages on the screen

- Replace the waste toner bottle when the following message appears on the screen:
"Replacement Required: Waste Toner Bottle"
- Prepare a waste toner bottle when the following message appears on the screen:
"Replace Required Soon: Waste Toner Bottle"

★ Important

- Waste toner bottles cannot be reused.
- When removing the waste toner bottle, make sure not to tilt it.
- Make sure the transfer unit is installed. If the transfer unit is not installed, install it before turning on the power.
- Before removing the waste toner bottle from the machine, spread paper or similar material around the area to keep toner from dirtying your workspace.

1. Pull the front cover open lever and then carefully lower the front cover.

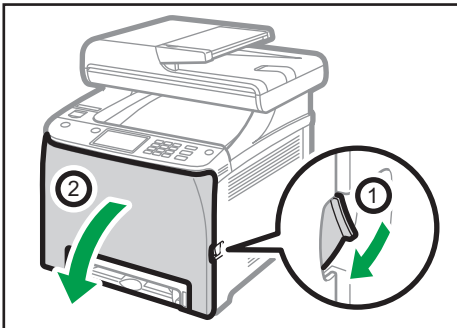

ECC115

2. Slide the lever in front of the transfer unit forward.

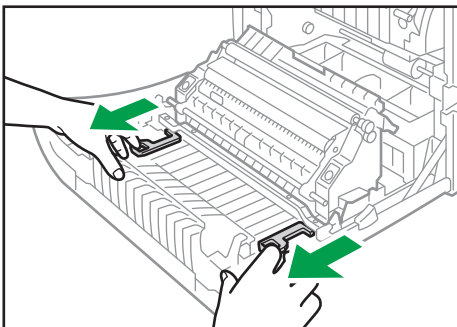

ECC135

3. Holding the tabs on both ends of the transfer unit, tilt it backwards and lift it up.

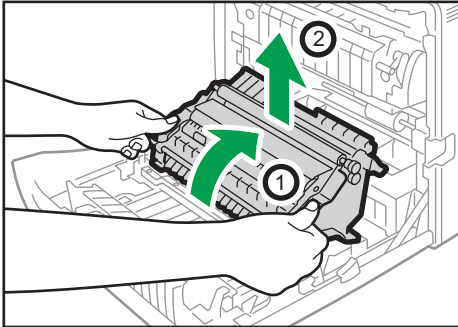

ECC136

4. Holding the handle at the center of the waste toner bottle, carefully pull it partially out without tilting it.

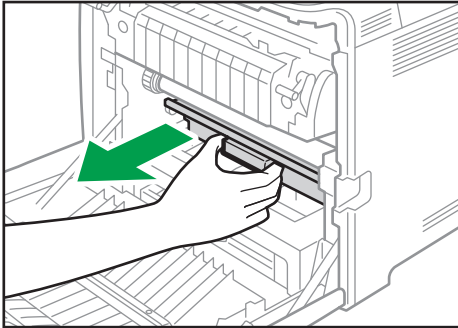

ECC137

5. Pull the waste toner bottle halfway out, hold the bottle firmly, and then pull it straight out.

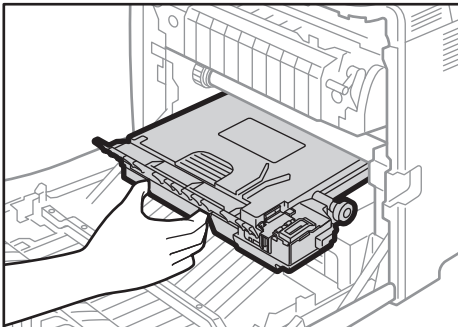

ECC138

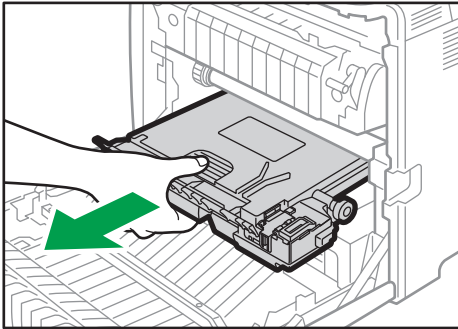

ECC139

To prevent the waste toner bottle from coming into contact with the intermediate transfer unit (the position shown by the arrow in the illustration below), do not lift the bottle while pulling it out.

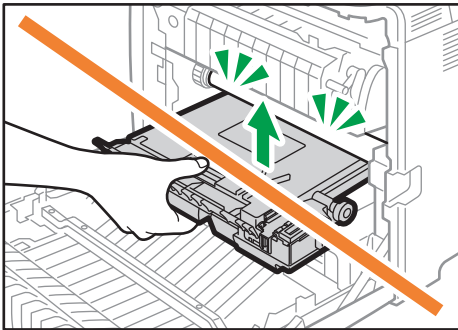

ECC140

6. Close the bottle cap.

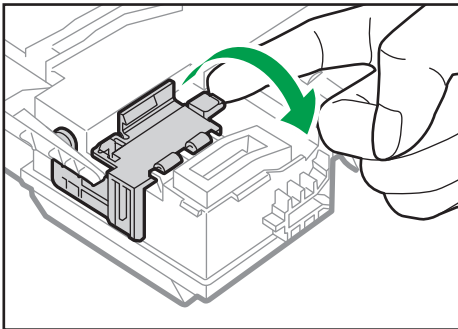

ECC141

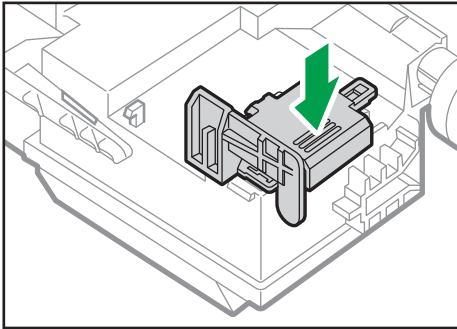

ECC142

7. Holding the center of the new waste toner bottle, carefully insert it halfway into the machine body.

Leave the bottle cap open.

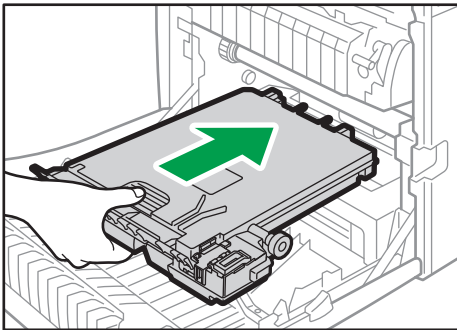

ECC143

To prevent the waste toner bottle from coming into contact with the intermediate transfer unit (the position shown by the arrow in the illustration below), do not lift the bottle while inserting it.

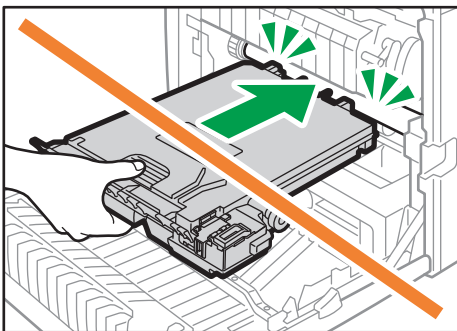

ECC144

8. Push in the waste toner bottle until it clicks.

Pressing the handle at the center, push the bottle all the way in.

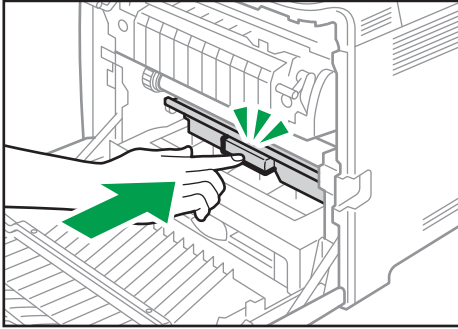

ECC145

- 9. Place the transfer unit on the front cover. Slide the transfer unit along the guide rails into the machine.**

Do not manually operate the pressure lever, because pressuring and depressing are interlocked with the front cover's position.

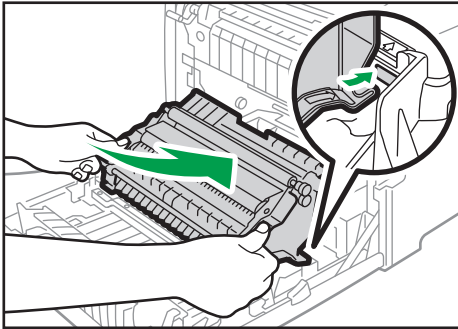

ECC146

- 10. When it stops, push on the PUSH mark until it clicks.**

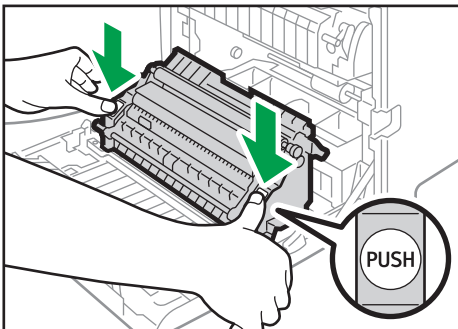

ECC147

11. Using both hands, carefully push up the front cover until it closes.

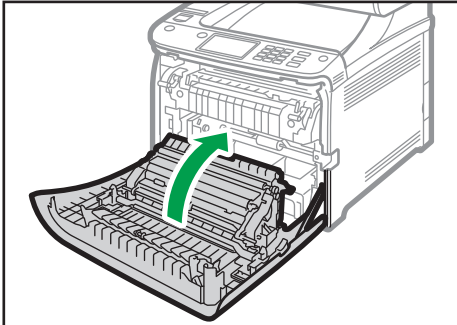

ECC117

When closing the front cover, push the upper area of the cover firmly.

Note

- For easy replacement, we recommend you purchase and store extra waste toner bottles.
- Comply with the waste toner bottle recycling program, whereby used waste toner bottles are collected for processing. For details, ask your sales or service representative.

Replacing a Component

Replacing the Intermediate Transfer Unit

If the Alert indicator on the control panel lights up and the "Replacement Required: Intermediate Transfer Unit" message appears on the display, contact your sales or service representative.

Replacing the Fusing Unit and Transfer Roller

If the Alert indicator on the control panel lights up and the "Replacement Required: Transfer Roller" or "Replacement Required: Fusing Unit" message appears on the display, contact your sales or service representative.

Cautions When Cleaning

Clean the machine periodically to maintain high print quality.

Dry wipe the exterior with a soft cloth. If dry wiping is not sufficient, wipe with a soft, damp cloth that has been wrung out thoroughly. If you still cannot remove the stain or grime, use a neutral detergent, wipe over the area with a thoroughly-wrung damp cloth, and then dry wipe the area and allow it to dry.

★ Important

- To avoid deformation, discoloration, or cracking, do not use volatile chemicals, such as benzine and thinner, or spray insecticide on the machine.
- If there is dust or grime inside the machine, wipe with a clean, dry cloth.
- You must disconnect the plug from the wall outlet at least once a year. Clean away any dust and grime from the plug and outlet before reconnecting. Accumulated dust and grime pose a fire hazard.
- Do not allow paper clips, staples, or other small objects to fall inside the machine.

Cleaning the Toner Density Sensor

Clean the toner density sensor when the following message appears on the control panel.

"Density Sensor Require Cleaning"

1. Pull up the lever on the top cover, and then carefully raise the top cover.

Make sure that the ADF is closed.

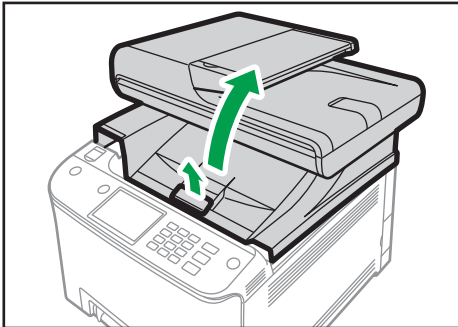

ECC128

2. Remove the rearmost print cartridge.

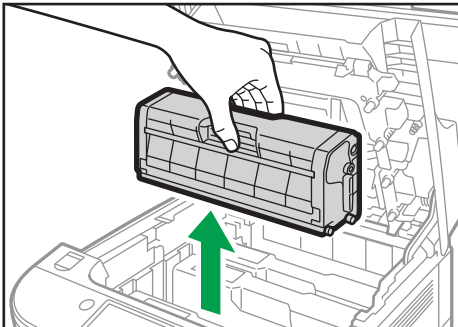

ECC167

3. Slide the toner density sensor lever once to the left.

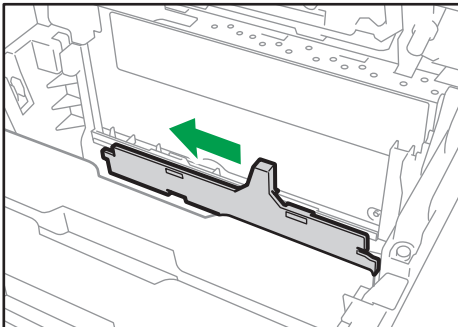

ECC148

4. Carefully insert the print cartridge removed in Step 2 vertically.

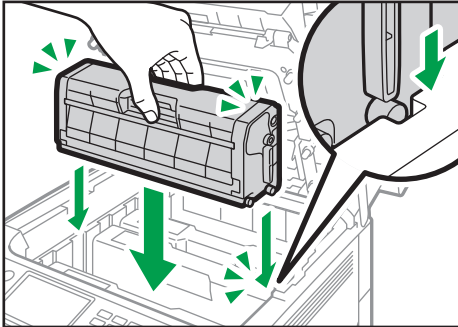

ECC132

5. Using both hands, hold the center of the top cover and close the cover carefully. Be careful not to trap your fingers.

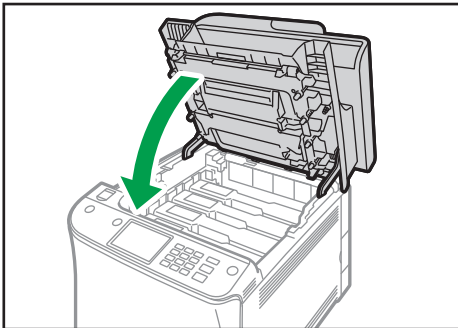

ECC133

Cleaning the Friction Pad and Paper Feed Roller

If the friction pad or paper feed roller is dirty, a multi-feed or misfeed might occur. In this case, clean the friction pad and paper feed roller as follows:

★ Important

- Do not use chemical cleaning fluids or organic solvents such as thinner or benzene.
1. Turn off the power.
 2. Unplug the power cord from the wall outlet. Remove all the cables from the machine.
 3. Pull out Tray 1 carefully with both hands.

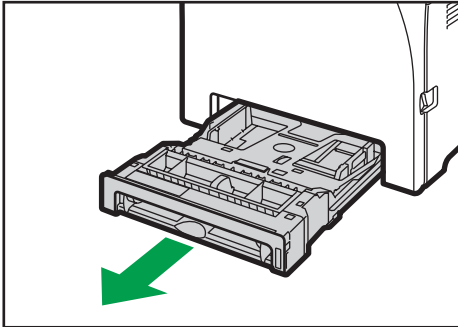

DUE214

Place the tray on a flat surface. If there is paper in the tray, remove it.

4. Wipe the friction pads with a damp cloth.

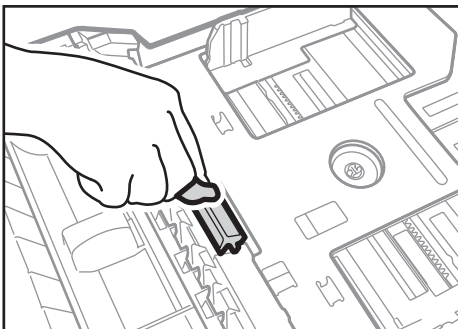

ECC149

- Wipe the rubber part of the roller with a soft damp cloth. After that, wipe it with a dry cloth to remove the moisture.

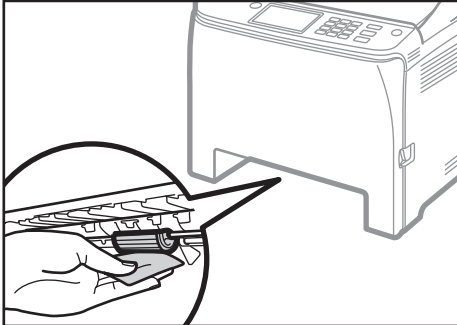

ECC150

- Push the metal plate down until it clicks.

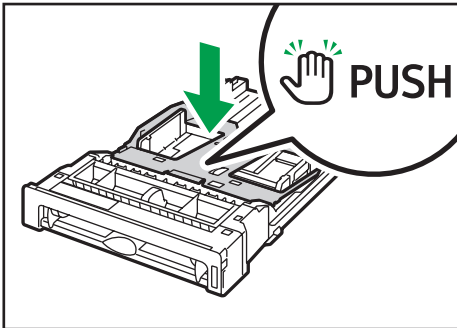

DUE215

- Reload the removed paper into the tray, and then push the tray carefully into the machine until it clicks into place.

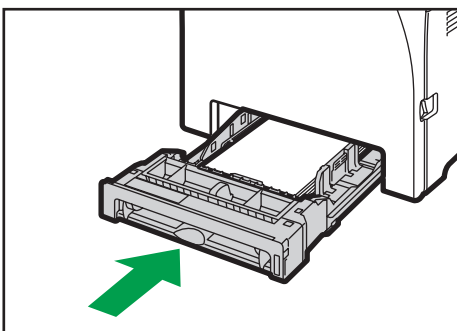

DUE220

- Insert the plug of the power cord into the wall socket securely. Connect all the interface cables that were removed.
- Turn on the power.

 **Note**

- If jams or multi-sheet feeds occur after cleaning the friction pad, contact your sales or service representative.
- If the optional Tray 2 is installed, clean its friction pad and paper feed roller in the same way as you did for Tray 1.

Cleaning the Registration Roller and Paper Tray

The registration roller and paper tray can become dirty with paper dust if you print to non-standard paper.

Clean the registration roller if white dots appear on prints.

★ Important

- Do not use chemical cleaning fluids or organic solvents such as thinner or benzene.
- Do not touch the transfer roller (as shown below).

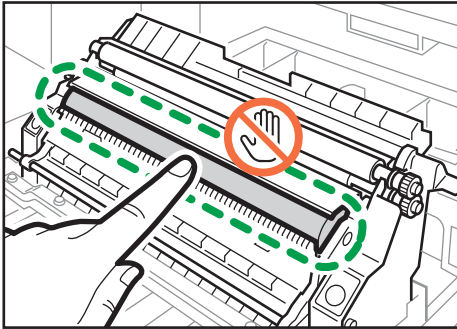

ECC151

1. Turn off the power.
2. Unplug the power cord from the wall outlet. Remove all the cables from the machine.
3. Pull out Tray 1 carefully with both hands.

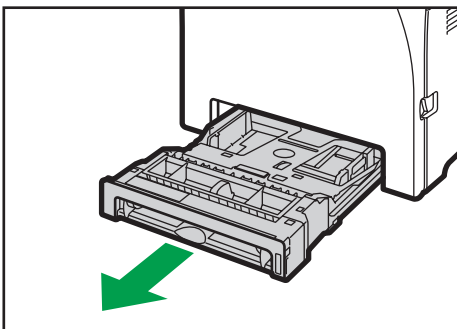

DUE214

Place the tray on a flat surface. If there is paper in the tray, remove it.

- 4. Wipe the inside of the paper tray with a cloth.

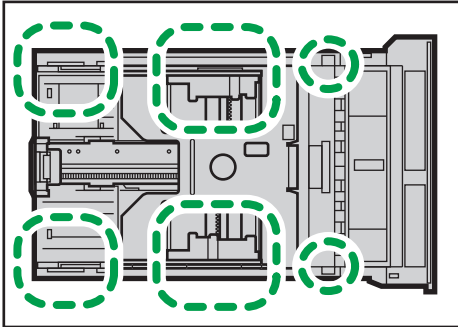

ECC152

- 5. Push the metal plate down until it clicks.

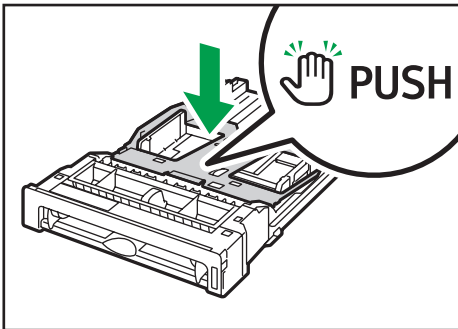

DUE215

- 6. Reload the removed paper into the tray, and then push the tray carefully into the machine until it clicks.

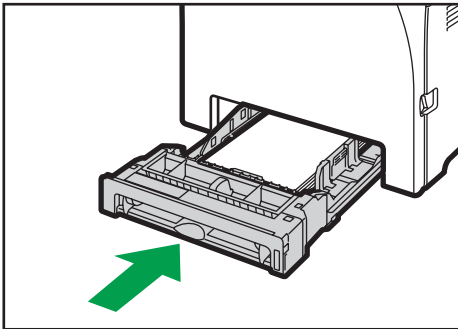

DUE220

7. Pull the front cover open lever and then carefully lower the front cover.

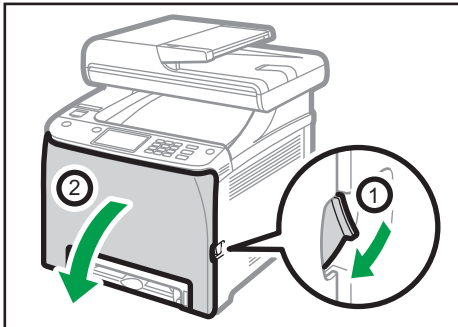

ECC115

Be sure to set the registration roller in the position shown by the arrow in the illustration below.

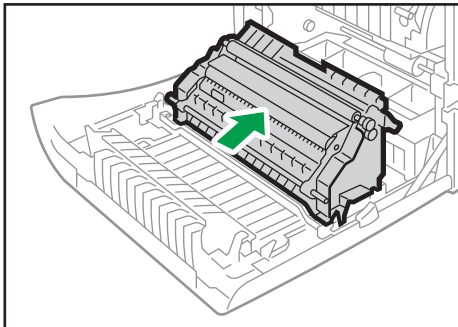

ECC153

Clean the registration roller if prints are smeared after a paper jam is cleared.

8. Clean the registration roller by applying a soft damp cloth while turning it.
9. Using both hands, carefully push up the front cover until it closes.

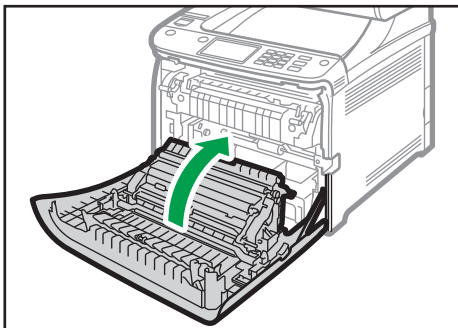

ECC117

When closing the front cover, push the upper area of the cover firmly.

10. Plug in the power cord securely. Connect all the cables that were removed.
11. Turn on the power.

Cleaning the Exposure Glass

1. Lift the ADF.

Be careful not to hold the input tray when lifting the ADF, for the tray might be damaged.

- 2. Clean the parts indicated with arrows with a soft damp cloth and then wipe the same parts with a dry cloth to remove any remaining moisture.**

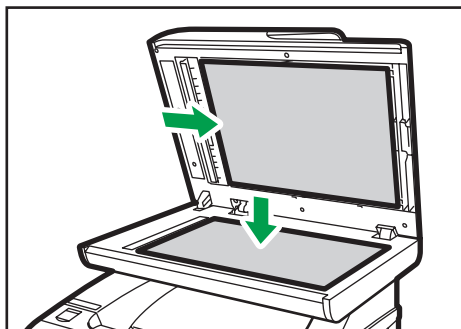

DUE285

Cleaning the Auto Document Feeder

1. Lift the ADF.

Be careful not to hold the input tray when lifting the ADF, for the tray might be damaged.

- ## 2. Clean the parts indicated with arrows with a soft damp cloth and then wipe the same parts with a dry cloth to remove any remaining moisture.

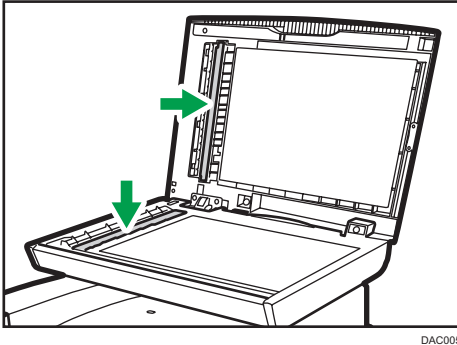

DAC005

3. Close the ADF.

4. Open the ADF cover.

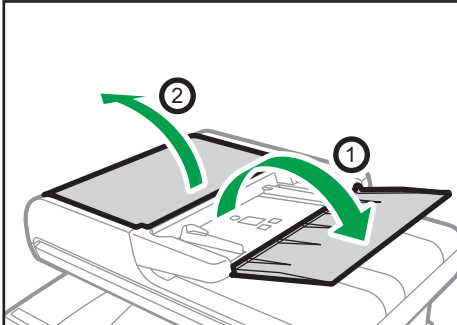

ECC154

5. Clean the parts indicated below.

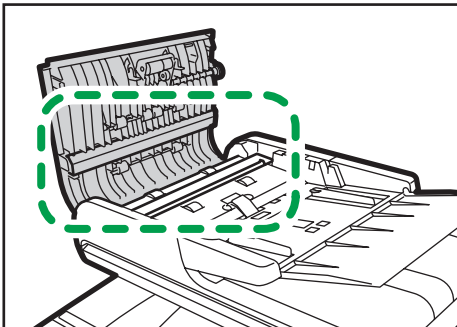

DUE322

6. Close the ADF cover.

Moving and Transporting the Machine

This section provides cautions that you must follow when moving the machine both short and long distances.

Repack the machine in its original packing materials when moving it over a long distance.

★ Important

- **Be sure to disconnect all cables from the machine before transporting it.**
- **The machine is a precision piece of machinery. Be sure to handle it carefully when moving it.**
- **Make sure to move the machine horizontally. Take extra caution when carrying the machine up or down stairs.**
- **If Tray 2 is installed, remove it from the machine, and move them separately.**
- **Do not remove the print cartridge when moving the machine.**
- **Be sure to hold the machine level while carrying it. To prevent toner from spilling, move the machine carefully.**
- Keep the machine away from salt-bearing air and corrosive gases. Also, do not install the machine in places where chemical reactions are likely (laboratories, etc.), as doing so will cause the machine to malfunction.

Ventilation

When you use this machine in a confined space without good ventilation for a long time or print large quantities, you might detect an odd smell.

This might cause the output paper to also have an odd smell.

When you detect an odd smell, regularly ventilate in order to keep the workplace comfortable.

- Set up the machine so that it does not directly ventilate towards people.
- Ventilation should be more than 30 m³/hr/person.

New machine smell

When a machine is new, it might have a unique smell. This smell will subside in about one week.

When you detect an odd smell, sufficiently ventilate and circulate the air in the room.

- 1. Be sure to check the following points:**
 - The power switch is turned off.
 - The power cord is unplugged from the wall outlet.
 - All other cables are unplugged from the machine.
- 2. If Tray 2 is installed, remove it.**

- 3. Standing at the front and back of the machine, two persons should lift the machine using the inset grips on the sides. Move it horizontally to the place where you want to use it.**

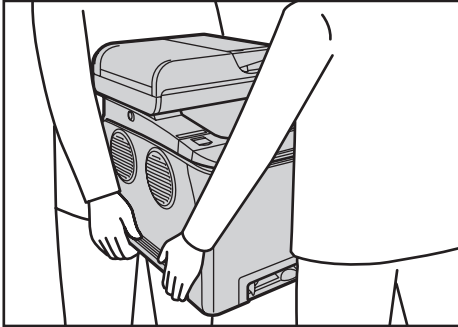

DUE287

- 4. If you have removed Tray 2, reinstall it.**

↓ Note

- To move the machine over a long distance, pack it well and empty all the paper trays. Take care not to tip or tilt the machine during transit.
- Toner might spill inside the machine if the machine is not kept level during transit.
- For more information about moving the machine, contact your sales or service representative.

Disposal

Ask your sales or service representative for information about correct disposal of this machine.

Where to Inquire

Contact your sales or service representative for further information about the topics included in this manual or to inquire about other topics not included in this manual.

10. Troubleshooting

This chapter provides solutions for error messages and other problems.

Error and Status Messages on the Screen

Messages are listed in alphabetical order in the table below.

"X" indicates a number in an error code that appear differently depending on a specific situation.

★ Important

- If the alert indicator lights up continuously or flashes, press the [Status] icon on the [Home] screen and check the displayed message.

Message	Causes	Solutions
2XXX14	The machine was not able to print the received fax, or the machine's memory reached capacity while receiving a fax because the document was too large.	<ul style="list-style-type: none">• The paper tray was empty. Load paper in the paper tray. See page 48 "Loading Paper".• The paper tray did not contain A4, Letter, or Legal size paper. Load valid size paper in the tray, and configure the paper size settings under [Paper Settings] accordingly.• A cover or tray was open. Close the cover or tray.• There was a paper jam. Remove the jammed paper. See page 349 "Removing Paper Jams".• A print cartridge was empty. Replace the print cartridge. See page 313 "Replacing the Print Cartridge".• The received fax was too large. Ask the sender to resend the document in parts as several smaller individual faxes, or to send at a lower resolution.

Message	Causes	Solutions
ADF Original Misfeed Open ADF Cover and remove paper.	An original has been jammed inside the ADF.	<ul style="list-style-type: none"> Remove jammed originals, and then place them again. See page 349 "Removing Paper Jams" and page 360 "Paper Feed Problems". Check the originals are suitable for scanning. See page 76 "Placing Originals".
Available: IDCard Copy A4, 8 ¹ / ₂ × 11, A5, A6	ID card copy could not be performed because the tray does not contain the valid size paper, which are A4, Letter, A5, or A6 size.	<ul style="list-style-type: none"> Set the machine to print copies using the A4 or Letter size paper in the [Select Paper] setting. See page 217 "Copier Settings". Specify the A4, Letter, A5, or A6 size paper for the tray selected for printing copies. See page 246 "Paper Settings".
Available: 2 Sided Copy A4/B5/LG/LT/EXE 8 × 13, 8 ¹ / ₄ × 13, 8 ¹ / ₂ × 13, 16K	2-sided copy could not be performed because the tray does not contain the valid size paper, which are A4, B5, Letter, Legal, Executive, 8 × 13 inches, 8 ¹ / ₂ × 13 inches, Folio, or 16K.	<ul style="list-style-type: none"> Select the tray containing the A4, B5, Letter, Legal, or Executive size paper (other than the bypass tray) in the [Select Paper] setting. See page 217 "Copier Settings". Specify the A4, B5, Letter, Legal, Executive, 8 × 13 inches, 8¹/₂ × 13 inches, Folio, or 16K size for the tray selected for printing copies. See page 246 "Paper Settings".
Available: 2 Sided Copy Tray 1 or Tray 2	2-sided copy could not be performed because paper is specified to be fed from the bypass tray.	Specify a setting other than [Bypass Tray] for the [Select Paper] setting. See page 217 "Copier Settings".
Busy	Fax transmission could not be completed because the destination's line was busy.	Wait for a while and send the fax again.

Message	Causes	Solutions
Cannot Copy This Setting Combine.: 2 page on 1 / 4 page on 1	Combined copying could not be performed because the tray does not contain the valid size paper, which are A4, Letter, or Legal size.	<ul style="list-style-type: none"> Set the machine to print copies using the A4, Letter, or Legal size paper in the [Select Paper] setting. See page 217 "Copier Settings". Specify the A4, Letter, or Legal size paper for the tray selected for printing copies. See page 246 "Paper Settings".
Cannot copy. Set original to ADF.	Combined copying could not be performed because the originals were not placed in the ADF.	<ul style="list-style-type: none"> Use the ADF, even when copying a single sheet. If you need to use the exposure glass, select [Off] or [Manual 2Sd Scan Mode] in [Duplex/Combine] under [Copier Settings], and then try again. See page 217 "Copier Settings".
Check Paper Size	The paper size set for the document differs from the size of the paper in the indicated tray.	Press [FormFeed] to begin printing, or press [JobReset] to cancel the job.
Check Paper Type	The paper type set for the document differs from the type of the paper in the indicated tray.	Press [FormFeed] to begin printing, or press [JobReset] to cancel the job.
Connection Failed	The line could not be connected correctly.	<ul style="list-style-type: none"> Confirm that the telephone line is properly connected to the machine. Disconnect the telephone line from the machine, and connect a standard telephone in its place. Confirm that you can make calls using the telephone. If you cannot make calls this way, contact your telephone company.
Cover open	A cover is open.	Close the cover completely.
Density Sensor Require Cleaning	The machine failed to adjust color registration.	Clean the toner density sensor. See page 326 "Cleaning the Toner Density Sensor".

Message	Causes	Solutions
Dial Failed	The fax could not be sent.	<ul style="list-style-type: none"> • Confirm that the fax number you dialed is correct. • Confirm that the destination is a fax machine. • Confirm that the line is not busy. • You may need to insert a pause between dial digits. Press [Redial] after, for example, the area code. • Check that [PSTN / PBX] in [Administrator Tools] has been specified in accordance with the telephone line in use. See page 251 "Administrator Tools Settings".
Exceeded Maximum Email Size	The scan file exceeds the size limit for files that can be sent through e-mail.	<ul style="list-style-type: none"> • Configure [Resolution] under [Scan Settings] to reduce the scanning resolution. See page 222 "Scanner Settings". • Configure [Max. E-mail Size] under [Scan Settings] to increase the allowed size. See page 222 "Scanner Settings".
Failed to Access File Press Clear key	The Scan to USB function failed because the machine could not access the USB flash disk properly.	Use a USB flash disk that is not password- or write-protected.
Failed to Create File Press Clear key	The Scan to USB function failed because there was not enough memory on the USB flash disk.	Use a USB flash disk with enough memory.

Message	Causes	Solutions
I-Fax POP3 Failed	Connection to the POP3 server failed.	<ul style="list-style-type: none"> • Confirm that the network cable is properly connected to the machine. • Confirm that the network settings such as IP address, DNS, and POP3 settings have been configured properly (make sure that no double-byte character is used). See page 293 "Configuring the Network Settings".
Independent-supply Toner: X	A non-supported print cartridge is installed for the indicated color.	Remove and replace it with a print cartridge specified by an authorized dealer.
Internal Misfeed	Paper has been jammed in the machine.	Remove the jammed paper. See page 349 "Removing Paper Jams".
Memory Overflow	The number of fax jobs in memory (unsent or unprinted faxes) has reached maximum, so new jobs cannot be stored.	Wait until pending jobs have been transmitted or printed.
Memory Overflow	<ul style="list-style-type: none"> • The data is too large or complex to print. • When performing printing on Legal size paper under certain print quality setting, print data becomes too large and the job may be canceled. 	<ul style="list-style-type: none"> • Select [600 × 600 1bit] in [PCL Resolution] in [PCL Menu] or [PS Resolution] in [PS Menu] under [Printer Settings] to reduce the size of data. See page 242 "Printer Settings". • If using the PCL printer driver, set [Gradation:] in [Print Quality] to [Speed] or [Standard]. If using the PostScript 3 printer driver, set [Print Quality] in [Printer Features] to [Standard] or [High Quality].

Message	Causes	Solutions
Memory Overflow	<ul style="list-style-type: none"> If you try to print a Locked Print file stored in the machine with the printer driver's [Gradation:] set to [Fine] in the [Print Quality] tab, printing may be canceled depending on the machine's current memory usage. 	<ul style="list-style-type: none"> Print or delete other Locked Print files in the machine, and then print the Locked Print file that the machine failed to print. Alternately, resend the Locked Print file to the machine with [Gradation:] set to [Speed] or [Standard], and then print the Locked Print file.
Memory Overflow	<ul style="list-style-type: none"> The machine's memory reached capacity while scanning the first page of the original to store a fax job in memory before transmission. The machine's memory reached capacity while storing a fax in memory in Memory Transmission mode. 	Resend the fax in parts as several smaller individual faxes, or send at a lower resolution.
Misfeed: Duplex Unit Remove Paper	Paper has been jammed in the duplex unit.	Remove the jammed paper. See page 349 "Removing Paper Jams".
Misfeed: Paper Tray	Paper has been jammed in the paper tray.	Remove the jammed paper. See page 349 "Removing Paper Jams".
Misfeed: Standard Tray	Paper has been jammed in the paper exit area.	Remove the jammed paper. See page 349 "Removing Paper Jams".
Misfeed: Tray 1	Paper has been jammed in the tray 1 paper input area.	Remove the jammed paper. See page 349 "Removing Paper Jams".
Misfeed: Tray 2	Paper has been jammed in the paper tray.	Remove the jammed paper. See page 349 "Removing Paper Jams".
Net Communication Error	Connection with the server was lost while sending or receiving data.	Contact the network administrator.

Message	Causes	Solutions
Network is not Ready	A scanned file could not be sent because the machine has not received IP address information from the DHCP server completely.	Wait until the machine receives the IP address information completely, and then try the operation again.
On Hook or Stop key	The machine has been off-hook for an extended period of time.	Put down the handset phone or press the [Clear/Stop] key.
Out of Paper: X	The indicated tray has run out of paper.	Load paper to the indicated tray. See page 48 "Loading Paper".
Please Restart Machine	The machine needs to be restarted.	Turn off the power, and then turn it back on.
Remove Paper: Bypass Tray	The machine failed to proceed with the print job, because tray 1 or Tray 2 was specified as the input tray but paper was set in the bypass tray.	Remove paper from the bypass tray.
Replace Intermediate Transfer Belt	The transfer belt is no longer usable, and must be replaced.	Contact your sales or service representative.
Replace Required Soon: Toner Cartridge (X)	The print cartridge is almost empty.	Prepare a new print cartridge.
Replace Required Soon: Waste Toner Bottle	The waste toner bottle needs to be replaced soon.	Prepare a new waste toner bottle.
Replacement Required: Fusing Unit	The fusing unit is no longer usable, and must be replaced.	Contact your sales or service representative.
Replacement Required: Paper Feed Roller	The paper feed roller is no longer usable, and must be replaced.	Contact your sales or service representative.

Message	Causes	Solutions
Replacement Required: Toner Cartridge (X)	The machine has run out of toner.	Replace the print cartridge. See page 313 "Replacing the Print Cartridge".
Replacement Required: Transfer Roller	The transfer roller is no longer usable, and must be replaced.	Contact your sales or service representative.
RX Communication Error	A reception error occurred, and the fax could not be received correctly.	If possible, contact the sender of the fax and ask them to resend it.
Scan (NW) Disconnected	A scanned file could not be sent because the Ethernet cable was not connected properly.	Reconnect the Ethernet cable properly, and then try the operation again.
Scan (USB) Disconnected	The USB cable was disconnected while scanning from a computer.	Reconnect the USB cable properly, and then try the operation again.
Server Connection Failed	A scanned file could not be sent because the destination could not be reached.	Confirm that the destination is registered correctly, and then try the operation again.
Server Response Error	An error occurred in communication with the server before beginning transmission.	Confirm that the destination is registered correctly, and then try the operation again. If the problem could not be solved, contact the network administrator.
SCXXX	A fatal hardware error has occurred, and the machine cannot function.	Contact your sales or service representative.
Set Correct Paper	The tray selected in [Select Paper Tray] under [Fax Settings] does not contain A4, Letter, or Legal size paper.	While the message is displayed, press [Set Size]. A menu for changing the paper size of the current tray appears. Load A4/Letter/ Legal size paper in the tray, and then select the corresponding paper size. Note that the paper size setting for the tray under [Paper Settings] will be changed. See page 246 "Paper Settings".

Message	Causes	Solutions
Set Original to ADF Cannot use exposure glass with set. in [Scan Size].	Scanning could not be performed because the originals were not placed in the ADF, even though the machine is set to scan originals larger than A4/Letter size.	<ul style="list-style-type: none"> • Use the ADF, even when scanning A4/Letter or smaller size originals. • If you need to use the exposure glass, set A4/Letter or smaller size in [Scan Size] under [Scan Settings], and then try again. See page 167 "Specifying Scan Settings for Scanning".
Sort Copy was Cancelled	The machine's memory reached capacity while originals were being scanned from the ADF to perform sort copying.	Press [Exit] to print the originals that were successfully scanned into memory. Then, copy again the originals left in the ADF.
Setting Error: Waste Toner Bottle	The waste toner bottle has been installed incorrectly.	Reinstall the waste toner bottle. See page 318 "Replacing the Waste Toner Bottle".
TX Communication Error	A transmission error occurred, and the fax could not be transmitted correctly.	If the [Auto Redial] setting is enabled, the machine will redial the number and try again. If all attempts fail, or if the machine is in Immediate Transmission mode, the fax will not be transmitted. Try the operation again.
Unavailable Paper Type	2-sided copy could not be performed because the tray does not contain the valid type paper, which is thin, plain, middle thick, recycled, color, preprinted or prepunched.	<ul style="list-style-type: none"> • Specify the tray containing the valid type paper (other than the bypass tray) in the [Select Paper] setting. See page 217 "Copier Settings". • Specify the valid paper type for the tray selected for printing copies. See page 246 "Paper Settings".
Unsupported Device Please Remove	The Scan to USB function failed because a USB device other than a USB flash disk or a USB flash disk with an unsupported file system was used.	Use a USB flash disk that is compatible with the Scan to USB function.

Message	Causes	Solutions
Unsupported USB Hub Please Remove	The Scan to USB function failed because a USB device other than a USB flash disk or a USB flash disk with an unsupported file system was used.	Use a USB flash disk that is compatible with the Scan to USB function.
USB Disconnected Press Clear key	The Scan to USB function failed because the USB flash disk was removed before the operation could be completed.	Check that the USB flash disk is securely inserted in the machine. Do not pull out the USB flash disk until "Ready" appears on the display.
USB Memory Overflow Press Clear key	The Scan to USB function failed because there was not enough memory on the USB flash disk.	Use a USB flash disk with enough memory.
Write Protect Press Clear key	The Scan to USB function failed because the machine could not access the USB flash disk properly.	Use a USB flash disk that is not password- or write-protected.

Removing Paper Jams

If a paper jam occurs, one of the following messages appears on the control panel:

★ Important

- If the alert indicator lights up continuously or flashes, press the [Status] icon on the [Home] screen and check the displayed message.

Message	Reference title
Internal Misfeed	See page 352 "If paper jams inside the fusing unit".
Misfeed: Standard Tray	
Misfeed: Paper Tray	See page 354 "If paper jams inside a tray".
Misfeed: Tray 1	
Misfeed: Tray 2	
Misfeed: Duplex Unit Remove Paper	See page 356 "If paper jams inside the transfer unit".
ADF Original Misfeed Open ADF Cover and remove paper.	See page 357 "Removing Scanning Jams".

See the section identified by the message and remove the jammed paper accordingly.

Removing Printing Jams

⚠ CAUTION

- The inside of this machine becomes very hot. Do not touch the parts labeled "△" (indicating a hot surface).
- Some of this machine's internal components get very hot. For this reason, take care when removing misfed paper. Not doing so could result in burns.
- Some of the internal components of this machine might be fragile. When you remove jammed paper, do not touch the sensors, connectors, LEDs, or other fragile parts that are shown in this manual. Doing so may cause malfunctions.

For the location of the sensors in the machine and extended options, see the following illustrations.

Main unit

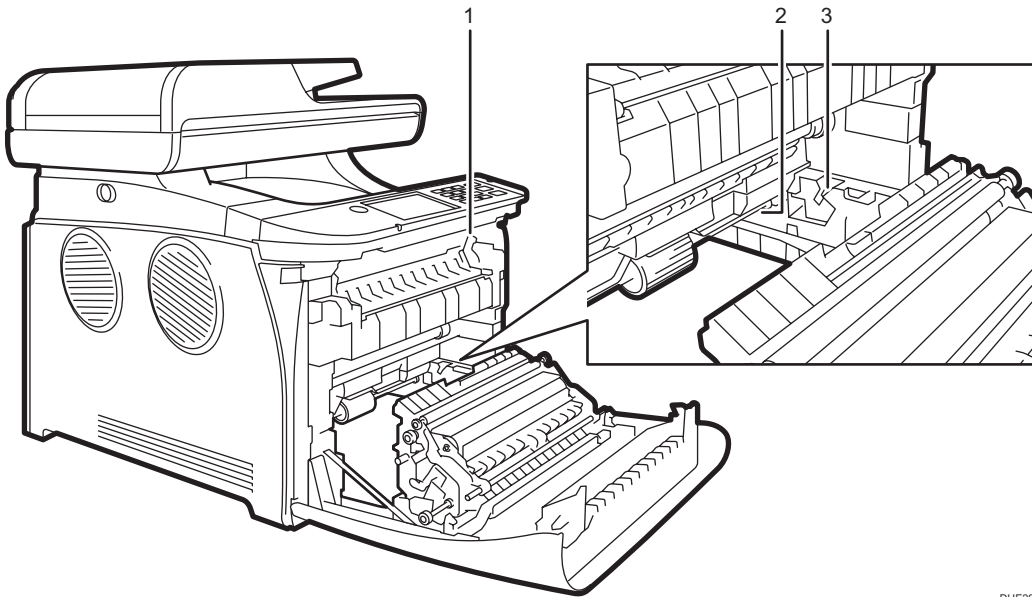

DUE292

1.



DUE288

2.

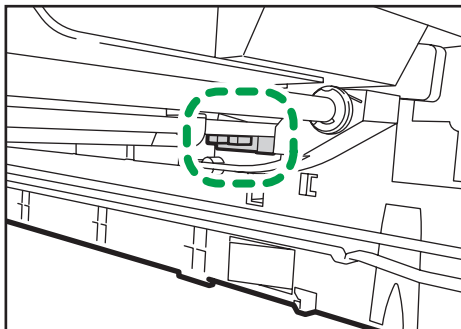

DUE289

3.

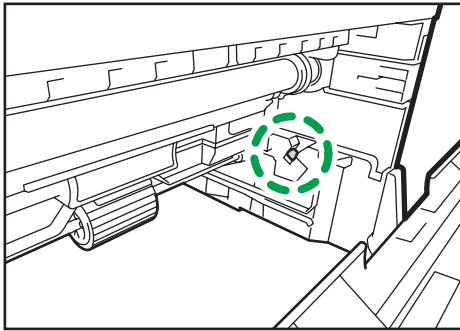

DUE290

Waste toner bottle

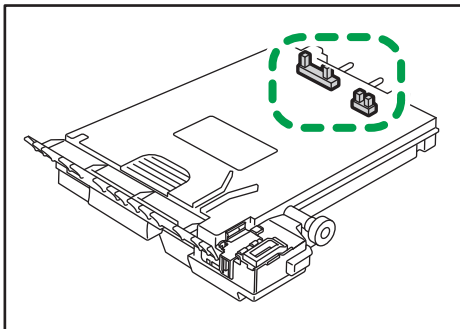

ECC168

Paper feed unit

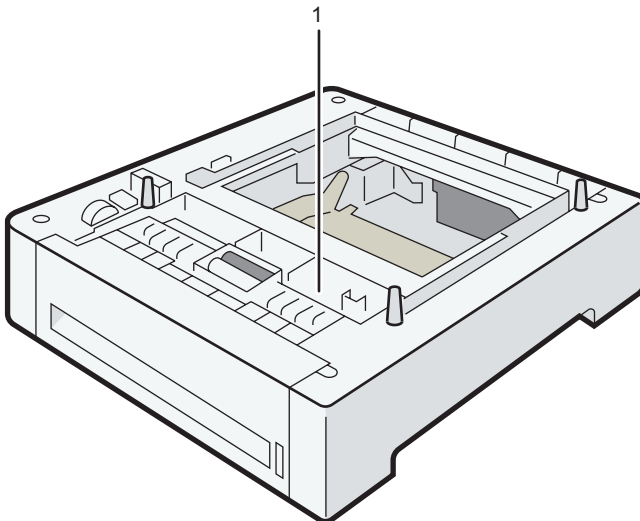

DUE320

1.

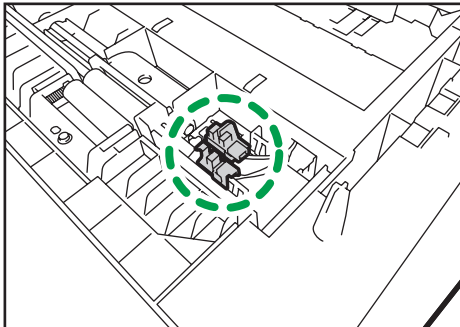

DUE291

★ Important

- Jammed paper may be covered in toner. Be careful not to get toner on your hands or clothes.
- Toner on prints made immediately after clearing a paper jam may be insufficiently fused and may smudge. Make test prints until smudges no longer appear.
- Do not forcefully remove jammed paper, as it may tear. Torn pieces remaining inside the machine will cause further jams and possibly damage the machine.
- Paper jam can cause pages to be lost. Check your print job for missing pages and reprint any pages that did not print out.

If paper jams inside the fusing unit

If paper jams inside the fusing unit, follow the procedure below to remove it.

★ Important

- Since the temperature around the guide is high, wait for it to cool down before checking for jammed paper.

1. Pull the front cover open lever and then carefully lower the front cover.

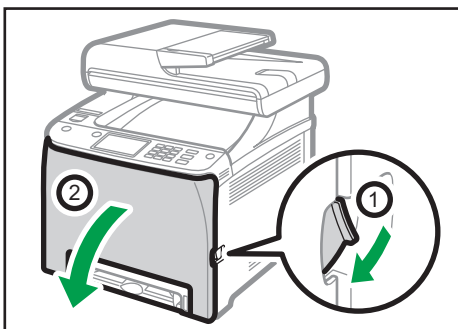

ECC115

2. Pull the paper downward to remove it. Do not pull it upward.

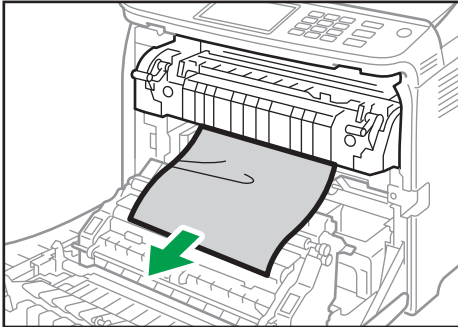

ECC158

Do not touch the fusing unit.

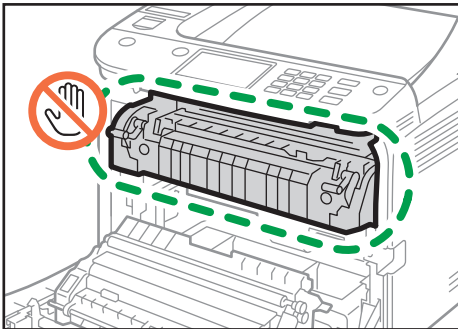

ECC157

If you cannot find the jammed paper, check for it by pulling down the guide.

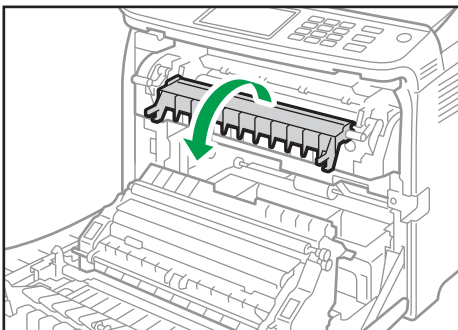

ECC159

3. Using both hands, carefully push up the front cover until it closes.

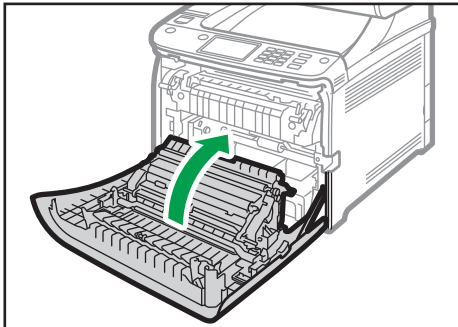

ECC117

When closing the front cover, push the upper area of the cover firmly. After closing the cover, check that the error is cleared.

If paper jams inside a tray

If paper jams in Tray 1 or 2, follow the procedure below to remove it.

1. Pull the front cover open lever and then carefully lower the front cover.

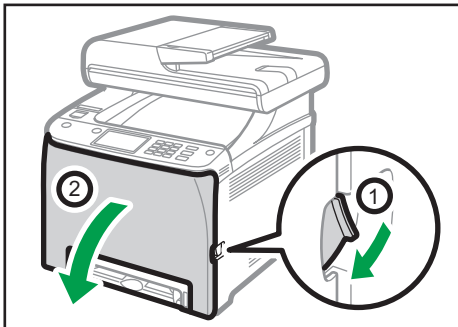

ECC115

2. Pull out the jammed paper carefully.

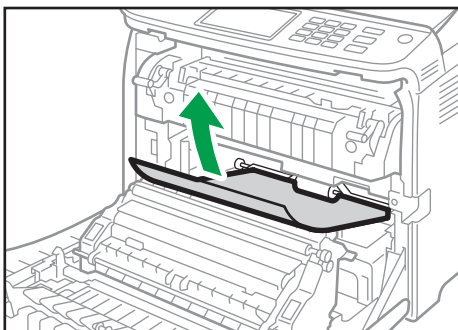

ECC160

Do not touch the fusing unit.

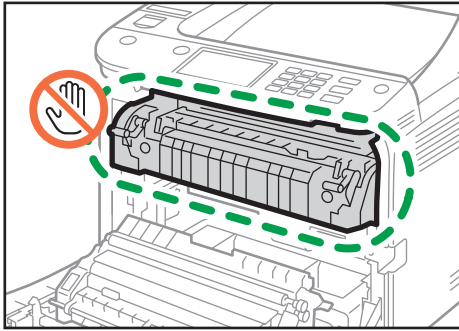

ECC157

If paper has jammed inside the transfer unit, holding both sides of the paper, pull the paper carefully forward and out.

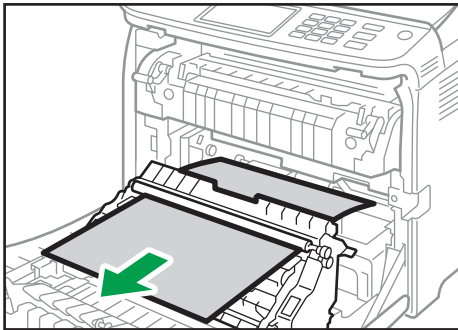

ECC161

3. Using both hands, carefully push up the front cover until it closes.

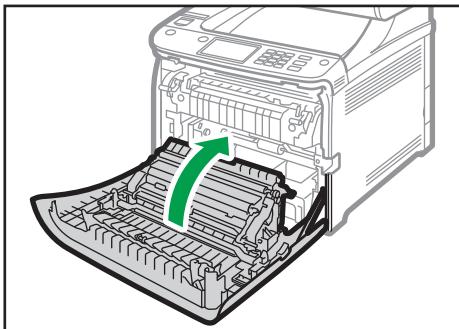

ECC117

When closing the front cover, push the upper area of the cover firmly. After closing the cover, check that the error is cleared.

Note

- Do not pull out the paper tray (Tray 1).
- If paper jams in Tray 2 but is difficult to locate, pull out Tray 2 to remove it. After removing the paper, carefully push Tray 2 squarely back into the machine.

If paper jams inside the transfer unit

If paper jams inside the transfer unit, follow the procedure below to remove it.

1. Pull the front cover open lever and then carefully lower the front cover.

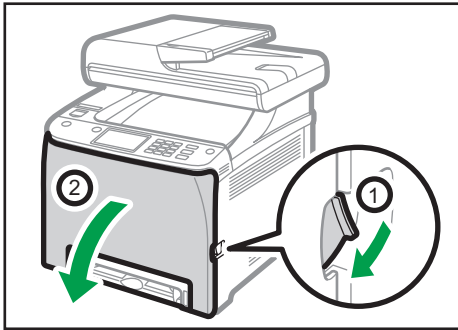

ECC115

2. Carefully remove any paper that is jammed under the transfer unit.

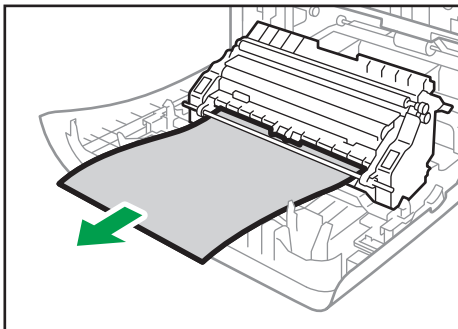

ECC162

If you cannot find the jammed paper, look inside the machine.

3. Using both hands, carefully push up the front cover until it closes.

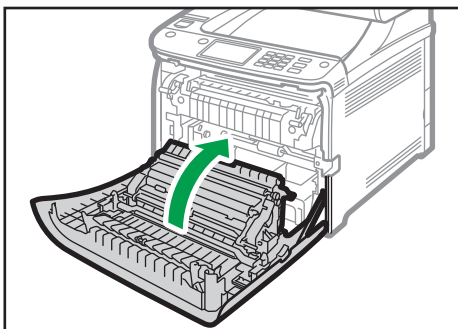

ECC117

When closing the front cover, push the upper area of the cover firmly. After closing the cover, check that the error is cleared.

Removing Scanning Jams

★ Important

- Be careful not to hold the input tray when lifting the ADF, for the tray might be damaged.

If a paper jam occurs in the ADF, follow the procedure below to remove the jammed paper.

1. Open the ADF cover.

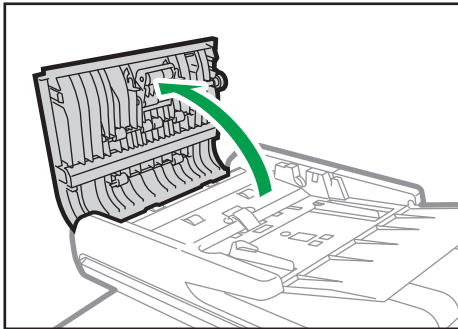

2. Gently pull the jammed paper to remove it.

Be careful not to pull the original too hard, as it may rip.

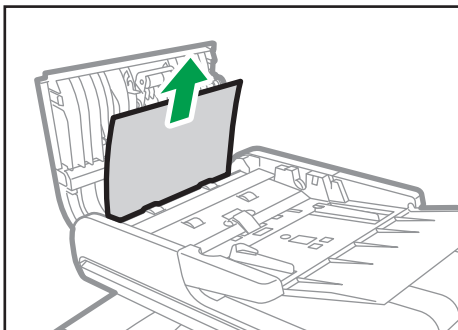

3. Close the ADF cover and the cover of the input tray for ADF.

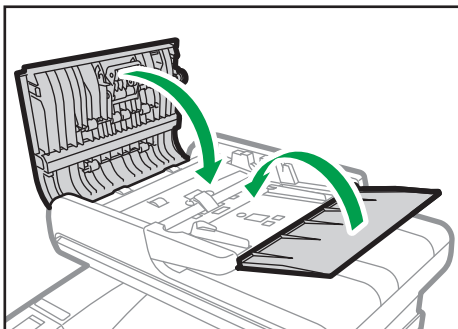

- 4. Lift the ADF, and if there is any original remaining in the ADF, gently pull the jammed paper to remove it.**

Be careful not to hold the input tray when lifting the ADF. Doing so may damage the tray.

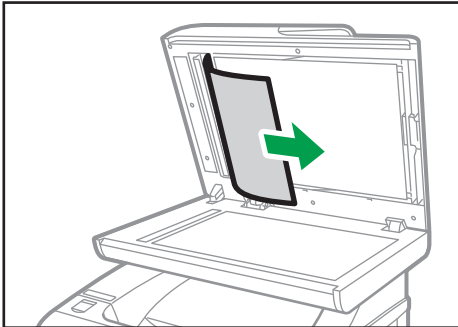

ECC166

- 5. Close the ADF.**

When You Cannot Print Test Page



Possible cause	Solution
The power cord, a USB cable, or a network cable is not connected correctly.	Make sure that the power cord, USB cable, and network cable are connected correctly. Also confirm that they are not damaged.
The port connection is not established correctly.	<ol style="list-style-type: none">1. On the [Start] menu, click [Devices and Printers].2. Right-click the icon of the machine, and then click [Printer properties].3. Click the [Ports] tab, and then make sure that the port is set as a USB or network printer.

Paper Feed Problems

If the machine is operating but paper will not feed or paper jams occur frequently, check the condition of the machine and paper.

Problem	Solution
Paper does not feed smoothly.	<ul style="list-style-type: none"> • Use supported types of paper. See page 62 "Supported Paper". • Load paper correctly, making sure that the side or end fences of the paper tray, or the paper guides of the bypass tray are properly adjusted. See page 48 "Loading Paper". • If the paper is curled, straighten the paper. • Take out the paper from tray and fan it well. Then, reverse the top and bottom of the paper, and put it back in the tray.
Paper jams occur frequently.	<ul style="list-style-type: none"> • If there are gaps between the paper and the side or end fences of the paper tray, or the paper guides of the bypass tray, adjust the side or end fences of the paper tray, or the paper guides of the bypass tray to remove the gaps. • Avoid printing on both sides of paper when printing images that contain large solid areas, which consume a lot of toner. • Use supported types of paper. See page 62 "Supported Paper". • Load paper only as high as the upper limit markings on the side fence. • Make sure that the friction pads and paper feed rollers are clean. See page 328 "Cleaning the Friction Pad and Paper Feed Roller".

Problem	Solution
Multiple sheets of paper are fed at one time.	<ul style="list-style-type: none"> • Fan the paper well before loading. Also make sure that the edges are even by tapping the stack on a flat surface such as a desk. • Make sure that the side or end fences are in the right position. • Use supported types of paper. See page 62 "Supported Paper". • Load paper only as high as the upper limit markings on the side fence.. • Make sure that the friction pads and paper feed rollers are clean. • Check that paper was not added while there was still some left in the tray. Only add paper when there is none left in the tray.
Paper gets wrinkles.	<ul style="list-style-type: none"> • Paper is damp. Use paper that has been stored properly. See page 62 "Supported Paper". • Paper is too thin. See page 62 "Supported Paper". • If there are gaps between the paper and the side or end fences of the paper tray, or the paper guides of the bypass tray, adjust the side or end fences of the paper tray, or the paper guides of the bypass tray to remove the gaps.
The printed paper is curled.	<ul style="list-style-type: none"> • Load the paper upside down in the paper tray. • If the paper curl is severe, take prints from the output tray more frequently. • Paper is damp. Use paper that has been stored properly. See page 62 "Supported Paper". • Select [Curl Prevented] in [Curl Prevention Mode] under [System Settings].

Problem	Solution
<p>Images are not printed in the right position</p>  <p>DAC606</p>	<p>Adjust the front end fence and both side fences to match the paper size.</p> <p>See page 48 "Loading Paper".</p>
<p>Images are printed diagonally to the pages.</p>  <p>DAC572</p>	<p>If there are gaps between the paper and the side or end fences of the paper tray, or the paper guides of the bypass tray, adjust the side or end fences of the paper tray, or the paper guides of the bypass tray to remove the gaps.</p>

Print Quality Problems

Checking the Condition of the Machine

If there is a problem with the quality of printing, first check the condition of the machine.

Possible Cause	Solution
There is a problem with the machine's location.	Make sure that the machine is on a level surface. Place the machine where it will not be subject to vibration or shock.
Unsupported types of paper is used.	Make sure that the paper being used is supported by the machine. See page 62 "Supported Paper".
The paper type setting is incorrect.	Make sure that the paper type setting of the printer driver matches the type of paper loaded. See page 60 "Specifying Paper Type and Paper Size Using the Printer Driver".
A non-genuine print cartridge is being used.	Refilled or non-genuine print cartridge reduces print quality and can cause malfunctions. Use genuine print cartridge only.
An old print cartridge is being used.	Print cartridge should be opened before their expiration date and used within six months of being opened.
The machine is dirty.	See page 313 "Maintaining the Machine", and clean the machine as required.
Color degradation has occurred.	Color degradation may occur in color printing after the machine is moved or a large number of pages are printed. In this case, adjust color registration by executing [Color Registration] in [System Settings].

Checking the Printer Driver Settings

Problem	Solution
The printed image is smudged.	<p>PCL 5c/6</p> <p>On the printer driver's [Paper] tab, select [Bypass Tray] in the "Input Tray:" list. In the "Paper Type:" list, select a proper paper type.</p> <p>PostScript 3</p> <p>On the printer driver's [Paper/Quality] tab, select [Bypass Tray] in the "Paper Source" list. In the "Media" list, select a proper paper type.</p>
Images smudge when rubbed. (Toner is not fixed.)	<p>PCL 5c/6</p> <p>On the printer driver's [Paper] tab, select a proper paper type in the "Paper Type:" list.</p> <p>PostScript 3</p> <p>On the printer driver's [Paper/Quality] tab, select a proper paper type in the "Media" list.</p>
The printed image is different from the image on the computer's display.	<p>Only when using PCL 5c/6</p> <p>On the printer driver's [Print Quality] tab, select [Raster] in the "Graphics Mode" list.</p>
When printing graphics, the output and the screen are different.	<p>To print accurately, specify the printer driver setting to print without using the graphics command. For details about specifying the printer driver setting, see the printer driver Help.</p>
Images are cut off, or excess is printed.	<p>Use the same size paper selected in the application. If you cannot load paper of the correct size, use the reduction function to reduce the image, and then print. For details about the reduction function, see the printer driver Help.</p>
Photo images are coarse.	<p>Use the application's or printer driver's settings to specify a higher resolution.</p> <p>For details about the printer driver's settings, see the printer driver Help.</p>
A solid line is printed as a dashed line or appears blurred.	<p>Change the dithering settings on the printer driver. For details about the dithering settings, see the printer driver Help.</p>

Problem	Solution
Fine lines are fuzzy, of inconsistent thickness, or do not appear.	Change the dithering settings on the printer driver. For details about the dithering settings, see the printer driver Help. If the problem persists, specify the settings of the application in which the image was created to change the thickness of the lines.

Printer Problems

This section describes printing problems and possible solutions.

When You Cannot Print Properly

Problem	Solution
An error occurs.	<p>If an error occurs when printing, change the computer or printer driver settings.</p> <ul style="list-style-type: none"> • Check the printer icon name does not exceed 32 alphanumeric characters. If it does, shorten it. • Check whether other applications are operating. Close any other applications, as they may be interfering with printing. If the problem is not resolved, close unneeded processes too. • Check that the latest printer driver is being used.
A print job is canceled.	<ul style="list-style-type: none"> • Printing on Legal size paper may be canceled, if the printing is performed with a certain print quality setting. If using the PCL printer driver, set [Gradation:] in [Print Quality] to [Speed] or [Standard]. If using the PostScript 3 printer driver, set [Print Quality] to [Standard] or [High Quality]. For details, see the printer driver Help. • If [I/O Timeout] under [System Settings] is set to 15 seconds, increase the time period. A print job may be canceled if printing is frequently interrupted by data from other ports, or if printing data is large and takes time for processing. For details, see page 234 "System Settings".

Problem	Solution
A Locked Print file is canceled.	<ul style="list-style-type: none"> • The machine already has 5 jobs or 5 MB of Locked Print data. Print or delete an existing Locked Print file. For details, see page 91 "Printing Confidential Documents". • Even if the machine cannot store any more Locked Print files, the machine holds the new Locked Print file for the period of time specified in [Locked Print] under [System Settings] before canceling that file. Within this time, you can print or delete the new Locked Print file. You can also print or delete an existing Locked Print file so that the new Locked Print file can be stored in the machine. • For details about [Locked Print], see page 234 "System Settings"
A Locked Print file is canceled.	<p>Only when using PCL 5c/6</p> <p>The Locked Print file has too many pages or it is too large. Reduce the number of pages to print, or print with a lower setting for [Gradation:] in [Print Quality]. For details, see the printer driver Help.</p>
There is a considerable delay between the print start command and actual printing.	<ul style="list-style-type: none"> • Processing time depends on data volume. High volume data, such as graphics-heavy documents, take longer to be processed. • To speed up printing, reduce the printing resolution using the printer driver. For details, see the printer driver Help. • The machine is calibrating color. Wait for a while.
Documents are not printed properly when using a certain application, or image data is not printed properly. Some characters are printed faintly or not printed.	Change the print quality settings.

Problem	Solution
It takes too long to complete the print job.	<ul style="list-style-type: none"> • Photographs and other data intensive pages take a long time to be processed so simply wait when printing such data. • Changing the settings with printer driver may help to speed up printing. See the printer driver Help. • The data is so large or complex that it takes a long time to be processed. • If "Processing..." is displayed on the screen, the machine is receiving data. Wait for a while. • The printer is adjusting the color registration. Wait for a while.
A printed image is different from the image on the computer's display.	<ul style="list-style-type: none"> • When you use some functions, such as enlargement and reduction, the layout of the image might be different from that displayed in the computer display. • Check that the page layout settings are properly configured in the application. • Make sure the paper size selected in the printer properties dialog box matches the size of the paper loaded. For details, see the printer driver Help.
Images are cut off, or excess pages are printed.	<p>If you are using paper whose size is smaller than the paper size selected in the application, use the same size paper selected in the application. If you cannot load paper of the correct size, use the reduction function to reduce the image, and then print.</p> <p>See the printer driver Help.</p>

Problem	Solution
<p>The color of the printout is different from the color on the computer's display.</p>	<ul style="list-style-type: none"> The colors made using color toner may be different from colors displayed on the display due to the difference of methods to reproduce colors. <p>Only when using PCL 5c/6</p> <p>Color gradation might appear differently if On is selected for [Economy Color] on the [Print Quality] tab in the printer driver's dialog box.</p> <p>See the printer driver Help.</p> <ul style="list-style-type: none"> Turn off the main power, and then turn it back on. If the color still appears different on the printout, perform the [Color Registration] under [System Settings]. For details, see page 234 "System Settings". <p>If this procedure fails to resolve the problem, contact your sales or service representative.</p>
<p>Color changes extremely when adjusted with the printer driver.</p>	<p>Only when using PCL 5c/6</p> <p>Do not make extreme settings for the color balance under the [Print Quality] tab in the printer driver's dialog box.</p> <p>See the printer driver Help.</p>
<p>Color documents are printed in black and white.</p>	<ul style="list-style-type: none"> The printer driver is not set up for color printing. <p>See the printer driver Help.</p> <ul style="list-style-type: none"> Some applications print color files in black and white.

When You Cannot Print Clearly

Problem	Solution
The whole printout is blurred.	<ul style="list-style-type: none"> • The paper being used may be damp. Use paper that has been stored properly. See page 62 "Supported Paper". • Select [Curl Prevented] in [Curl Prevention Mode] under [System Settings]. • If you enable [Toner Saving] under [System Settings], printing is generally less dense. • If you select [On] for [Economy Color] in the [Print Quality] tab (PCL printer driver) or under [Printer Features] (PostScript 3 printer driver), print will be at lower density. For details, see the printer driver Help. • The print cartridge is almost empty. If "Replacement Required: Toner Cartridge (X)" ("X" indicates the toner color) appears on the screen, replace the indicated print cartridge. • Condensation may have occurred. If rapid change in temperature or humidity occurs, use this machine only after it has acclimatized.
Toner smears appear on the print side of the page.	<ul style="list-style-type: none"> • The paper setting may not be correct. For example, although you are using thick paper, the setting for thick paper may not be specified. Check the printer driver's paper settings. See the printer driver Help. • Check that the paper is not curled or bent. Envelopes can be curled easily. Flatten out the paper before loading it. See page 48 "Loading Paper". • Set [Fix Quality Improved] in [Fixing Quality Mode] under [System Settings].

Problem	Solution
<p>White lines appear.</p> 	<p>The intermediate transfer belt is dirty.</p> <p>Follow the procedure below to clean the belt:</p> <ol style="list-style-type: none"> 1. Open the top cover while the power is on. 2. Remove all print cartridges from the printer. 3. The machine automatically starts cleaning. Once cleaning is complete, the error message "Toner Set Error: (X)" appears ("X" indicates the toner color). 4. When cleaning finishes, open the top cover and attach all the print cartridges again. <p>If this procedure does not resolve the problem, the exposure glass or ADF may be stained. Perform cleaning according to page 334 "Cleaning the Exposure Glass" and page 335 "Cleaning the Auto Document Feeder". If the lines remain even after cleaning, contact your service representative.</p>
<p>Horizontal lines appear on the printed paper.</p>	<ul style="list-style-type: none"> • Impact can cause lines to appear on printed paper and other malfunctions. <p>Protect the printer from impact at all times, especially while it is printing.</p> <ul style="list-style-type: none"> • If lines appear on prints, turn the printer off, wait a few moments, and then turn it back on again. Then, perform the print job again.
<p>The print color is different from the color specified.</p>	<p>If a specific color is missing, turn the power switch off and on. If this does not resolve the problem, contact your sales or service representative.</p>
<p>Photo images are coarse.</p>	<p>Some applications lower the resolution for making prints.</p>

Problem	Solution
A color is missing or a printed image is partially blurred.	<ul style="list-style-type: none"> • The paper being used may be damp. Use paper that has been stored properly. See page 48 "Loading Paper". • Toner is almost empty. If the following message appears on the control panel, replace the print cartridge: "Replacement Required: Toner Cartridge (X)". ("X" indicates the toner color) See page 313 "Replacing the Print Cartridge". • Condensation may have occurred. If rapid change in temperature or humidity occurs, use this printer only after it has acclimatized.
Color shift occurs.	Perform the [Color Registration] under [System Settings]. For details, see page 234 "System Settings".
White spots appear.	The surrounding registration roller or paper tray can become dirty with paper dust if you use paper other than standard paper. Wipe any paper dust off both the paper tray and registration roller. See page 331 "Cleaning the Registration Roller and Paper Tray".
Colorless dots appear on solid color printouts.	Change the paper type currently selected in the Paper Type settings, and then print. Eg. [Recycled Paper] to [Thin Paper] to [Plain Paper]. See page 56 "Specifying Paper Type and Paper Size Using the Control Panel".
White streaks or color streaks appear.	Toner is almost empty. If an error message appears on the control panel, replace the print cartridge of the color indicated. See page 313 "Replacing the Print Cartridge".

Problem	Solution
The backs of printed sheets are blemished.	<ul style="list-style-type: none"> • When removing a jammed sheet, the inside of the printer may have become dirty. Print several sheets until they come out clean. • If document size is larger than paper size, e.g. A4 document on B5 paper, the back of the next printed sheet may become dirty.
The message "Processing..." does not appear on the control panel after printing.	<p>If the message "Processing..." does not appear on the control panel after printing, the printer has not received the data.</p> <p>If the printer is connected to the computer using the interface cable.</p> <p>Check the port connection setting is correct.</p> <p>Network Connection</p> <p>Contact your network administrator.</p>
Black gradation is not natural.	<p>Only when using PostScript 3</p> <p>Select [CMY + K] for [Gray Reproduction] in the printer driver's dialog box.</p> <p>See the printer driver Help.</p>
Solid lines are printed as broken lines.	<p>Only when using PostScript 3</p> <p>Change the [Dithering] setting in the printer driver's dialog box.</p> <p>See the printer driver Help.</p>
Fine dot patterns do not print.	<p>Only when using PostScript 3</p> <p>Change the [Dithering] setting in the printer driver's dialog box.</p> <p>See the printer driver Help.</p>
Solid areas, lines or text are shiny or glossy when created as a mixture of cyan, magenta, yellow.	<p>Only when using PostScript 3</p> <p>Select [Black by K] for [Gray Reproduction] in the printer driver's dialog box.</p> <p>See the printer driver Help.</p>

Problem	Solution
Speckling occurs in areas of solid black print.	<p>Only when using PostScript 3</p> <p>Select [CMY + K] for [Gray Reproduction] in the printer driver's dialog box.</p> <p>See the printer driver Help.</p>
If rubbed with your finger, the print smears.	<p>The setting of the paper may not be correct. For example, although thick paper is used, the setting for thick paper may not be specified.</p> <ul style="list-style-type: none"> • Check the paper settings of this printer. See page 48 "Loading Paper". • Check the paper settings of the printer driver. <p>See the printer driver Help.</p>

When Paper Is Not Fed or Ejected Properly

Problem	Solution
Prints fall behind the machine when they are delivered.	Pull up the appropriate stop fence (forward fence for A4/Letter, rear fence for Legal size prints). See page 17 "Guide to Components".
Prints do not stack properly.	<ul style="list-style-type: none"> • The paper being used may be damp. Use paper that has been stored properly. See page 62 "Supported Paper". • Pull up the appropriate stop fence (forward fence for A4/Letter, rear fence for Legal size prints). See page 17 "Guide to Components". • Select [Curl Prevented] in [Curl Prevention Mode] under [System Settings].

Problem	Solution
The printed paper is curled.	<ul style="list-style-type: none">• Load the paper upside down in the paper tray.• If the paper curl is severe, retrieve prints from the output tray more frequently.• The paper being used may be damp. Use paper that has been stored properly.• Select [Curl Prevented] in [Curl Prevention Mode] under [System Settings].• If you enable [Toner Saving] under [System Settings], printing is generally less dense.

Other Printing Problems

Problem	Solution
The toner has run out and printing has stopped.	When the "Continue printing?" message appears on the control panel, pressing [Yes] allows you to print a few more pages, but the print quality of those pages may be lower.

Copier Problems

When You Cannot Make Clear Copies

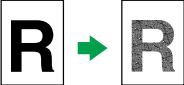
Problem	Solution
The printed copy is blank.	The original is not placed correctly. When using the exposure glass, place originals copy side down. When using the ADF, place them copy side up. See page 76 "Placing Originals".
The wrong original was copied.	If copying from the exposure glass, make sure that there are no originals in the ADF.
Copied pages do not look the same as the originals.	Select the correct scan mode according to the type of original. See page 120 "Specifying Scan Settings for Copying"
Black spots appear when photocopying a photographic print.	The original may have stuck to the exposure glass due to high humidity. Place the original on the exposure glass, and then place two or three sheets of white paper on top of it. Leave the ADF open when copying.
A moire pattern is produced. 	The original probably has heavily lined or dotted areas. Switching the setting for image quality between [Photo] and [Text/Photo] may eliminate the moire pattern. See page 120 "Specifying Scan Settings for Copying".
The printed copy is dirty.	<ul style="list-style-type: none"> Image density is too high. Adjust the image density. See page 120 "Adjusting Image Density". Toner on the printed surface is not dry. Do not touch printed surfaces immediately after copying. Remove freshly printed sheets one by one, taking care not to touch printed areas. The exposure glass or ADF is dirty. See page 313 "Maintaining the Machine". Before placing originals on the exposure glass, make sure that toner or correction fluid is dry.

Problem	Solution
When copying from the exposure glass, the print area of the copy is out of alignment with the original.	Place the original copy side down, making sure that it is aligned to the rear left corner and pressed flat against the exposure glass.

When You Cannot Make Copies as Wanted

Problem	Solution
Photocopied pages are not in correct order.	On the control panel, change the [Sort] setting under copy settings to collate pages as you require. For details about [Sort], see page 217 "Copier Settings".
Copied pages are too dark or too light.	Adjust the image density. See page 120 "Adjusting Image Density".
Cannot make copies with satisfactory tones.	Adjust the tone in [Color Adjustment] in [Copier Settings]. You can adjust the intensity of red, green and blue. See page 217 "Copier Settings".

Scanner Problems

When You Cannot Browse the Network to Send a Scan File

Problem	Solution
<p>The following machine settings may not be correct:</p> <ul style="list-style-type: none"> • IP address • Subnet Mask 	<p>Check the settings. See page 293 "Configuring the Network Settings".</p>

When Scanning Is Not Done As Expected

Problem	Solution
The machine does not start scanning.	The ADF or its cover is open. Close the ADF or its cover.
The scanned image is dirty.	<ul style="list-style-type: none"> • The exposure glass or ADF is dirty. See page 313 "Maintaining the Machine". • Before placing originals on the exposure glass, make sure that toner or correction fluid is dry.
The scanned image is distorted or out of position.	The original was moved during scanning. Do not move the original during scanning.
The scanned image is upside down.	The original was placed upside down. Place the original in the correct orientation. See page 76 "Placing Originals".
The scanned image is blank.	The original was placed with the front and back reversed. When using the exposure glass, place originals copy side down. When using the ADF, place originals copy side up. See page 76 "Placing Originals".
The scanned image is too dark or too light.	Adjust the image density. See page 167 "Specifying Scan Settings for Scanning".

Fax Problems

When You Cannot Send or Receive Fax Messages As Wanted

Transmission

Problem	Causes	Solutions
Cannot send files.	The telephone line may be disconnected.	Check if the telephone line is properly connected to the machine. For details, see Setup Guide.
	The machine cannot accept a new fax job because there are 5 unsent faxes in memory already.	Wait until any of these faxes is transmitted completely, or use the [Delete TX Stand.File] function to delete unnecessary faxes. For details, see page 224 "Fax Settings".
Document appears blank at the other end.	The original was placed upside down.	The original was placed upside down. Place the original in the correct orientation. See page 76 "Placing Originals".
Printed or sent images are spotty.	The exposure glass, exposure glass, exposure glass cover, or guide plate of the ADF is dirty.	Clean them. For details about how to clean the machine, see page 334 "Cleaning the Exposure Glass". Make sure ink or correction fluid is dry before placing originals.
Reception is possible, but transmission is not.	There are regions and telephone exchanges where a dial tone cannot be detected.	Contact your sales or service representative.
Transmission failed due to "maximum e-mail size" error.	If the e-mail size specified on the machine is too large, the Internet Fax document cannot be sent.	Change the setting for [Maximum Email Size] in [Scan Settings]. For details about the maximum e-mail size, see page 222 "Scanner Settings".

Problem	Causes	Solutions
When using On Hook Dial, "Receiving..." appears and transmission is not allowed.	If the machine fails to detect the size of the original when the [B&W Start] key is pressed, it performs a receiving operation.	Press [Scan Size] in [Scan Settings], select the scan size, and then resend the document.
LAN-Fax Driver does not work.	The entered login user name, login password, or driver encryption key is incorrect.	Check your login user name, login password, or driver encryption key, and then enter them correctly. For details, contact your administrator.

Reception

Problem	Causes	Solutions
Cannot receive files.	The telephone line may be disconnected.	Check if the telephone line is properly connected to the machine. For details, see Setup Guide.
The Receiving File indicator lights up and the received document is not printed.	The machine cannot print because it is out of paper or toner.	<ul style="list-style-type: none"> • Load paper into the tray. • Add toner. • The paper tray does not contain paper of the right size. Load paper of the right size in the paper tray.
The machine does not print received fax documents.	[Fax Settings] is configured to store received documents.	Print the fax documents using Web browser or the Print Stored RX File function. For details about printing received faxes stored in memory, page 211 "Printing Out Faxes Stored in Memory" and page 280 "Fax Tab".
The machine failed to print received fax documents.	The paper has run out.	Load paper into the tray.

Printing

Problem	Causes	Solutions
Print is slanted.	The paper is fed at a slant.	Load the paper correctly. For details about loading paper, see page 48 "Loading Paper".
Misfeeds occur frequently.	The number sheets loaded in the paper tray exceeds the capacity of the machine.	Load paper only as high as the upper limit markings inside the paper tray.
	The paper tray's side fence is set too tightly.	Pinch the fence lightly, and then adjust its position.
	The paper is too thick or too thin.	Use the recommended paper. For details about the recommended paper, see page 62 "Supported Paper".
	Printed paper is being used.	Do not load sheets that have already been copied or printed.
	Sheets are sticking together.	Fan the sheets thoroughly before loading them. Alternatively, feed the sheets into the machine one at a time.
Printed copies are together, resulting in jams.	Sheets are sticking together.	Fan the sheets thoroughly before loading them. Alternatively, feed the sheets into the machine one at a time.
Copy paper becomes creased.	Printed paper is being used.	Do not load sheets that have already been copied or printed.
	The paper is too thin.	Use the recommended paper. For details about the recommended paper, see page 62 "Supported Paper".
Edges of sheets are creased.	You are using a non-recommended paper.	Use the recommended paper. For details about the recommended paper, see page 62 "Supported Paper".
Black lines appear on the file printed at the destination.	The exposure glass, exposure glass, exposure glass cover, or guide plate of the ADF is dirty.	Clean the components. For details about how to clean the machine, see page 334 "Cleaning the Exposure Glass".

Problem	Causes	Solutions
The background of received images appears dirty. Images from the back of the page appear.	Image density is too high.	Adjust the image density. See page 167 "Specifying Scan Settings for Scanning".
Received image is too light.	When using moist, rough, or processed paper, areas of print may not be fully reproduced.	Use the recommended paper. For details about the recommended paper, see page 62 "Supported Paper".
	The image density has been specified too low.	Increase the image density. For details about how to change the density, see page 120 "Adjusting Image Density".
	The original of the transmitted fax was printed on paper that is too thin.	Ask the sender to reprint the original on thicker paper, and then fax it again.

When an Error Is Notified via a Report or E-mail

When a report is printed from the machine

Error Report

An Error Report is printed if a document cannot be successfully sent or received.

Possible causes include a problem with the machine or noise on the telephone line. If an error occurs during transmission, resend the original. If an error occurs during reception, ask the sender to resend the document.

- If an error happens frequently, contact your service representative.
- The "Page" column gives the total number of pages.

Power Failure Report

- Right after recovery from power failure, the internal battery needs to be sufficiently recharged to guard against future data loss. Keep the machine plugged in and the power on for about 24 hours after the power loss.

Even if the power is turned off, the contents of the machine memory (for example, programmed numbers) will not be lost. Lost items will include any fax documents stored in memory using Memory Transmission or Reception.

If a file deleted from memory, Power Failure Report is automatically printed as soon as the power is restored.

This report can be used to identify lost files. If a document stored for Memory Transmission was lost, resend it. If a document received by Memory Reception was lost, ask the sender to resend it.

Error Report (E-mail)

The Error Report (E-mail) is printed by the machine when it is unable to send an Error notification Email.

For details about the Error notification Email, see page 383 "When an error notification E-mail is received".

Transmission Error Report

The Transmission Error Report is printed by the machine when it is unable to send a Transmission Error Mail Notification. For details about the Transmission Error Mail Notification, see page 383 "When an error notification E-mail is received".

When an error notification E-mail is received

Error notification e-mail

The machine sends the Error Notification Email to the sender when it is unable to successfully receive a particular e-mail message by Internet Fax Function. A "cc" of this notification is also sent to the administrator's e-mail address if the address has been specified.

- If an incoming Internet Fax from another party bypasses the SMTP server, even if reception is not successful, an Error Mail Notification is not sent to the sender.
- You can select to send Error Notification Email using Web Image Monitor. For details, see page 293 "Configuring the Network Settings".
- If Error Notification Email cannot be sent, the Error Report (E-mail) is printed by the machine.
- If an error occurs when an e-mail is received via SMTP, the SMTP server sends an error notification e-mail to the originator of the document.

Server-generated error e-mail

The transmitting server sends this error e-mail to the originator of an e-mail that has failed to be transmitted successfully (due to reasons such as specifying an incorrect e-mail address).

- If an Internet Fax transmission bypasses the SMTP server, even if transmission is not successful, an error e-mail is not sent from the server.
- After a server-generated error e-mail is printed, the first page of the sent document is printed.

Transmission Error Mail Notification

If an e-mail fails to be sent due to a transmission error, the machine sends the Transmission Error Mail Notification to the sender. If an e-mail could not be sent using the forward function, the Transmission Error Mail Notification will be sent to the destination e-mail address for forwarding.

If there is an additional user-registered e-mail address or administrator e-mail address, the Transmission Error Mail Notification will be sent to that address.

- If Transmission Error Mail Notification cannot be sent, Transmission Error Report is printed by the machine.

Error Code

The table below describes the meaning of error codes that appear under "Results" on Fax Journal or transmission status report, and what to do when a particular error code appears.

"X" indicates a number in an error code that appear differently depending on the situation.

Error Code	Solution
1XXX11	<p>An original has been jammed inside the ADF while sending a fax in Immediate Transmission mode.</p> <ul style="list-style-type: none"> • Remove jammed originals, and then place them again. See page 360 "Paper Feed Problems". • Check the originals are suitable for scanning. See page 76 "Placing Originals".
1XXX21	<p>The line could not be connected correctly.</p> <ul style="list-style-type: none"> • Check if the telephone line is properly connected to the machine. • Disconnect the telephone line cord from the machine, and connect the cord to a telephone. Check if you can make calls using the telephone. If you cannot make calls this way, contact your telephone company. • If the problem persists, contact your sales or service representative.
1XXX22 to 1XXX23	<p>Dial fails when trying to send faxes.</p> <ul style="list-style-type: none"> • Check if that the fax number you dialed is correct. • Check if that the destination is a fax machine. • Check if that the line is not busy. • You may need to insert a pause between dial digits. Press [Redial] after, for example, the area code. • Check if [PSTN / PBX] under [Administrator Tools] has been specified properly for your connection method to the telephone network. See page 251 "Administrator Tools Settings".

Error Code	Solution
1XXX32 to 1XXX84	<p>An error occurred while sending a fax.</p> <ul style="list-style-type: none"> • Check if the telephone line is properly connected to the machine. • Disconnect the telephone line cord from the machine, and connect the cord to a telephone. Check if you can make calls using the telephone. If you cannot make calls this way, contact your telephone company. • If the problem persists, contact your sales or service representative.
2XXX14	<p>The machine was not able to print the received fax, or the machine's memory reached its capacity while receiving a fax because the document was too large.</p> <ul style="list-style-type: none"> • The paper tray was empty. Load paper in the paper tray. See page 48 "Loading Paper". • The tray selected in [Select Paper Tray] under [Fax Settings] did not contain A4, Letter, or Legal size paper. Load valid size paper in the tray, and configure the paper size settings under [Paper Settings] accordingly. • A cover or tray was open. Close the cover or tray. • There was a paper jam. Remove the jammed paper. See page 349 "Removing Paper Jams". • A print cartridge was empty. Replace the print cartridge. See page 313 "Replacing the Print Cartridge". • The received fax was too large. Ask the sender to re-send the document in parts as several smaller faxes, or to send the fax at a lower resolution.
2XXX32 to 2XXX84	<p>An error occurred while receiving a fax.</p> <ul style="list-style-type: none"> • Check if the telephone line is properly connected to the machine. • Disconnect the telephone line cord from the machine, and connect the cord to a telephone. Check if you can make calls using the telephone. If you cannot make calls this way, contact your telephone company. • If the problem persists, contact your sales or service representative.

Error Code	Solution
3XXX11	<p>Connection to the server failed while sending an Internet Fax.</p> <ul style="list-style-type: none"> • Check if the network cable is properly connected to the machine. • Check if the network settings such as the IP address, DNS, and SMTP settings have been configured properly (make sure that no double-byte character is used). See page 293 "Configuring the Network Settings".
3XXX12	<p>E-mail transmission failed while sending an Internet Fax.</p> <ul style="list-style-type: none"> • There was an error in the header of the e-mail. Check if the network settings such as the IP address, DNS, and SMTP settings have been configured properly (make sure that no double-byte character is used). See page 293 "Configuring the Network Settings".
3XXX13	<p>E-mail transmission failed while sending an Internet Fax.</p> <ul style="list-style-type: none"> • There was an error in the part header of the e-mail. Check if the network settings such as the IP address, DNS, and SMTP settings have been configured properly (make sure that no double-byte character is used). See page 293 "Configuring the Network Settings".
3XXX14	<p>E-mail transmission failed while sending an Internet Fax.</p> <ul style="list-style-type: none"> • There was an error in the converted TIFF file. Check if the network settings such as the IP address, DNS, and SMTP settings have been configured properly (make sure that no double-byte character is used). See page 293 "Configuring the Network Settings".
3XXX33	<p>The machine memory reached capacity while sending an Internet Fax.</p> <ul style="list-style-type: none"> • The fax was too large. Resend the document in parts as several smaller faxes, or send the fax at a lower resolution.

Error Code	Solution
4XXX21	Connection to the server failed while receiving an Internet Fax. <ul style="list-style-type: none"> • Check if the network cable is properly connected to the machine. • Check if the network settings such as the IP address, DNS, and POP3 settings have been configured properly (make sure that no double-byte character is used). See page 293 "Configuring the Network Settings".
4XXX22	E-mail reception failed while receiving an Internet Fax. <ul style="list-style-type: none"> • LIST command to the POP3 server failed. Ask the sender to check the e-mail settings.
4XXX23	E-mail reception failed while receiving an Internet Fax. <ul style="list-style-type: none"> • There was an error in the header of the e-mail. Ask the sender to check the e-mail settings.
4XXX24	E-mail reception failed while receiving an Internet Fax. <ul style="list-style-type: none"> • There was an error in the part header of the e-mail. Ask the sender to check the e-mail settings. • The e-mail had an invalid Content-Type, or an unsupported type of file (such as PDF or JPEG) was received. Ask the sender to check the file type.
4XXX25	E-mail reception failed while receiving an Internet Fax. <ul style="list-style-type: none"> • There was an error in the text part of the part body of the e-mail. Ask the sender to check the e-mail settings.
4XXX26	E-mail reception failed while receiving an Internet Fax. <ul style="list-style-type: none"> • There was an error in the received TIFF file (which resulted from a condition not indicated by the error codes 4XXX43 to 4XXX45). Ask the sender to check the TIFF file.
4XXX42	E-mail reception failed while receiving an Internet Fax. <ul style="list-style-type: none"> • There was an error in the part header of the e-mail. Ask the sender to check the e-mail settings.

Error Code	Solution
4XXX43	<p>A TIFF file could not be received via Internet Fax properly.</p> <ul style="list-style-type: none">The compression method of the received TIFF file was other than MH/MR/MMR. Ask the sender to check the TIFF file.
4XXX44	<p>A TIFF file could not be received via Internet Fax properly.</p> <ul style="list-style-type: none">The resolution of the TIFF file was not supported, or the width of the TIFF file was that of A3 or B4 paper. Ask the sender to check the TIFF file.
4XXX45	<p>A TIFF file could not be received via Internet Fax properly.</p> <ul style="list-style-type: none">The format of the TIFF file was other than TIFF-S/F. Ask the sender to check the TIFF file.
4XXX46	<p>The machine memory reached its capacity while receiving an Internet Fax.</p> <ul style="list-style-type: none">The fax was too large. Ask the sender to resend the document in parts as several smaller faxes, or send at a lower resolution.

Common Problems

This section describes how to troubleshoot common problems that may occur while operating the machine.

Problem	Possible cause	Solution
The machine does not turn on.	The power cord is not connected properly.	<ul style="list-style-type: none"> Make sure that the power plug is firmly inserted into the wall outlet. Make sure that the wall outlet is not defective by connecting another working device.
An error message is shown on the machine's screen.	An error has occurred.	See page 339 "Error and Status Messages on the Screen".
Pages do not print.	The machine is warming up or receiving data.	Wait until "Printing..." appears on the screen. If "Processing..." is displayed on the screen, the machine is receiving data.
Pages are not printed.	The interface cable is not connected correctly.	<ul style="list-style-type: none"> Reconnect the cable. Check that the interface cable is the correct type.
Strange noise is heard.	<ul style="list-style-type: none"> The supplies are not properly installed. If [Auto Cleaning] in [System Settings] is set to [On], the machine automatically cleans its interior periodically. 	<ul style="list-style-type: none"> Confirm that the supplies are properly installed. Wait until the cleaning has finished. This is not a malfunction.
The volume of the sounds produced by the machine is too loud.	The volume is set to the high level.	Adjust the volume of the beep, ring, speaker, and alarm sounds. For details, see page 234 "System Settings".
The volume of the sounds produced by the machine is too quiet.	The volume is muted or set to the low level.	Adjust the volume of the beep, ring, speaker, and alarm sounds. For details, see page 234 "System Settings".

Problem	Possible cause	Solution
The network setting may not have been configured properly or the 3G dongle may not be connected properly.	Using Web Image Monitor, check the setting and check whether printing can be performed.	If the problem persists, contact your service representative.
You cannot print after rebooting the computer.	The printer may be offline.	<p>The procedure in this section is an example based on Windows 10. The actual procedure may vary depending on the operating system you are using.</p> <ol style="list-style-type: none"> 1. On the [Start] menu, select [Control Panel] under [Windows System]. 2. Click [View devices and printers]. 3. Click the machine's icon, and then click [See what's printing]. 4. Click [Printer] on the menu bar, and then uncheck [Use Printer Offline].

 **Note**

- If any of these problems persist, turn off the power, pull out the power cord, and contact your sales or service representative.

11. Configuring Network Settings

This chapter describes how to connect the machine to the network and specify the network settings. Configurations differ according to the communication environment of your system.

Connecting the Machine to a Wired Network

Configuring the IPv4 Setting

1. Press the [Setting] icon on the [Home] screen.
2. Press [Network Settings].
3. If you are requested to enter a password, enter the password using the number keys, and then press [OK].

You can display the software keyboard by double tapping the entry area on the display.

A password for accessing the [Network Settings] menu can be specified in [Admin. Tools Lock] under [Administrator Tools] menu.

4. Press [IPV4 Configuration].
5. Press [IPV4 DHCP].
6. Select [Active] to automatically obtain the IP address or [Inactive] to specify the IP address manually.

If you have selected [Active], proceed to Step 11.

7. Enter the machine's IPv4 address in [IP Address].
8. Enter the subnet mask in [Subnet Mask].
9. Enter the gateway address in [Gateway Address].
10. Press [OK].
11. Turn off the machine, and then turn it back on.

Setup is completed.

Configuring the IPv6 setting

1. Press the [Setting] icon on the [Home] screen.
2. Press [Network Settings].
3. If you are requested to enter a password, enter the password using the number keys, and then press [OK].

You can display the software keyboard by double tapping the entry area on the display.

A password for accessing the [Network Settings] menu can be specified in [Admin. Tools Lock] under [Administrator Tools] menu.

- 4. Press [IPV6 Configuration].**
- 5. Press [IPV6 DHCP].**
- 6. Select [Active] to automatically obtain the IP address or [Inactive] to specify the IP address manually.**

If you have selected [Active], proceed to Step 12.

- 7. Press [Manually Set Address].**
- 8. Enter the machine's IPv6 address in [Manually Set Address].**
- 9. Enter the prefix length in [Prefix Length].**
- 10. Enter the gateway address in [Gateway Address].**
- 11. Press [OK].**
- 12. Turn off the machine, and then turn it back on.**

Setup is completed.

Connecting the Machine to a Wireless Network

There are four methods for connecting the machine to a wireless network:

- Using the Wi-Fi Setup Wizard
See page 393 "Using the Wi-Fi Setup Wizard".
- Using the WPS button
See page 394 "Using the WPS Button".
- Using a PIN code
See page 396 "Using a PIN Code".
- Using the Wi-Fi Direct
See Wi-Fi Direct Guide.

Using the Wi-Fi Setup Wizard

A router (access point) is needed to set up a connection.

Checking the SSID and encryption key

The SSID and Encryption key for the router (access point) may be printed on a label affixed to the router (access point). For details about the SSID and Encryption key, refer to the router (access point) manual.

Configuring settings using the control panel

Make sure the Ethernet cable is not connected to the machine.

1. **Check that the router (access point) is working correctly.**
When selecting [Detailed Setup], proceed to step 10.
2. **Press the [Home] key.**

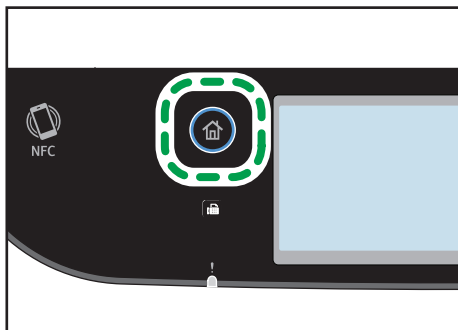

ECC202

3. **Press the [Setting] icon on the [Home] screen.**
4. **Press [Network Settings].**

- 5. If you are requested to enter a password, enter the password using the number keys, and then press [OK].**

You can display the software keyboard by double tapping the entry area on the display.

A password for accessing the [Network Settings] menu can be specified in [Admin. Tools Lock] under [Administrator Tools] menu.

- 6. Press [Wi-Fi Enable].**

- 7. Press [Enable].**

- 8. Turn off the machine, and then turn it back on.**

- 9. Press the wireless LAN icon.**

- 10. If you are requested to enter a password, enter the password using the number keys, and then press the [OK].**

You can display the software keyboard by double tapping the entry area on the display.

A password for accessing the [Wi-Fi Configuration] menu can be specified in [Admin. Tools Lock] under [Administrator Tools] menu.

- 11. Press [Setup Wizard].**

- 12. Press the SSID of the router (access point) from the searched SSID list.**

- 13. Enter the encryption key using the number keys, and then press the [Connect].**

As the passphrase, you can enter either 8 to 63 ASCII characters (0x20-0x7e) or 64 hexadecimal digits (0-9, A-F, a-f).

- 14. Check the result.**

- Connection has succeeded:
Configuring the Wi-Fi settings is complete.
- Connection has failed:
Check the configuration for the router (access point), and then try the connection again.

Using the WPS Button

A router (access point) is needed to set up a connection.

Make sure the Ethernet cable is not connected to the machine.

- 1. Check that the router (access point) is working correctly.**

When selecting [Detailed Setup], proceed to step 10.

2. Press the [Home] key.

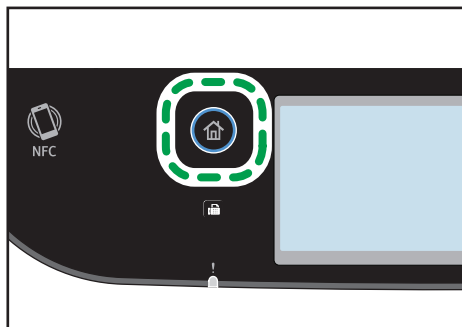

ECC202

3. Press the [Setting] icon on the [Home] screen.
4. Press [Network Settings].
5. If you are requested to enter a password, enter the password using the number keys, and then press [OK].

You can display the software keyboard by double tapping the entry area on the display.

A password for accessing the [Network Settings] menu can be specified in [Admin. Tools Lock] under [Administrator Tools] menu.

6. Press [Wi-Fi Enable].
7. Press [Enable].
8. Turn off the machine, and then turn it back on.
9. Press the wireless LAN icon.
10. If you are requested to enter a password, enter the password using the number keys, and then press the [OK].

You can display the software keyboard by double tapping the entry area on the display.

A password for accessing the [Wi-Fi Configuration] menu can be specified in [Admin. Tools Lock] under [Administrator Tools] menu.

11. Press [WPS].
12. Press [PBC].
13. Press [Connect].

"Please wait for 2 minutes" appears, and the machine starts to connect in PBC method.

14. Press the WPS button on the router (access point) within two minutes.

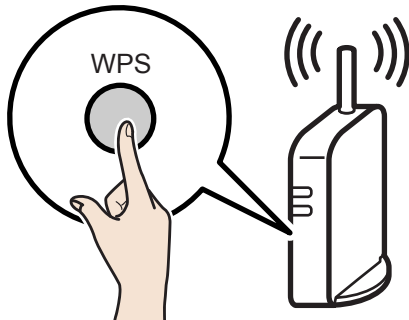

CHV607

For details about how to use the WPS button, refer to the manuals for the router (access point).

15. Check the result.

- Connection has succeeded:
Press [OK] to return to the screen displayed in Step 12, and then press the [Home] key to return to the initial screen.
Configuring the Wi-Fi settings is complete.
- Connection has failed:
Press [OK] to return to the screen displayed in Step 12. Check the configuration for the router (access point), then try the connection again.

Using a PIN Code

A router (access point) is needed to set up a connection. To establish a connection using the PIN code, use a computer that is connected to the router (access point).

Make sure the Ethernet cable is not connected to the machine.

- 1. Check that the router (access point) is working correctly.**
- 2. Open the PIN code configuration window (web page) for the router (access point) on your computer.**



When selecting [Detailed Setup], proceed to step 11.

3. Press the [Home] key.

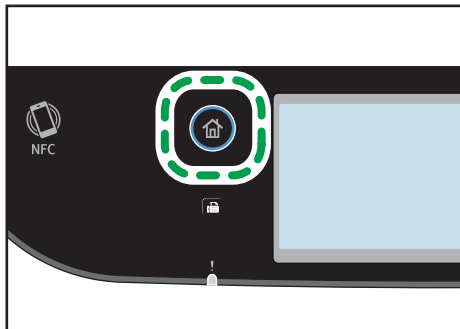

ECC202

4. Press the [Setting] icon on the [Home] screen.

5. Press [Network Settings].

6. If you are requested to enter a password, enter the password using the number keys, and then press [OK].

You can display the software keyboard by double tapping the entry area on the display.

A password for accessing the [Network Settings] menu can be specified in [Admin. Tools Lock] under [Administrator Tools] menu.

7. Press [Wi-Fi Enable].

8. Press [Enable].

9. Turn off the machine, and then turn it back on.

10. Press the wireless LAN icon.

11. If you are requested to enter a password, enter the password using the number keys, and then press [OK].

You can display the software keyboard by double tapping the entry area on the display.

A password for accessing the [Wi-Fi Configuration] menu can be specified in [Admin. Tools Lock] under [Administrator Tools] menu.

12. Press [WPS].

13. Press [PIN].

14. Check the PIN code.

Write down the PIN code in case you might forget it.

15. Enter the machine's PIN code (8 digits) on the router (access point)'s web page (The web page accessed in Step 2).

16. Execute WPS (PIN system) from the router (access point)'s web page.

17. Press [Connect].

"Please wait for 2 minutes" and connecting with PIN method starts.

18. Check the result.

- Connection has succeeded:
Press [OK] to return to the screen displayed in Step 13, and then press the [Home] key to return to the initial screen.
Configuring the Wi-Fi settings is complete.
- Connection has failed:
Press [OK] to return to the screen displayed in Step 13. Check the configuration for the router (access point), then try the connection again.

12. Appendix

This chapter describes the machine specifications and consumables.

Transmission Using IPsec

For securer communications, this machine supports the IPsec protocol. When applied, IPsec encrypts data packets at the network layer using shared key encryption. The machine uses encryption key exchange to create a shared key for both sender and receiver. To achieve even higher security, you can also renew the shared key on a validity period basis.

★ Important

- IPsec is not applied to data obtained through DHCP or DNS.
- IPsec compatible operating systems are Windows 7 or later, Windows Server 2008 or later, OS X 10.10 or later, Red Hat Enterprise Linux 6.8, 6.9, 6.10, 7.4, 7.5, and 7.6. However, some setting items are not supported depending on the operating system. Make sure the IPsec settings you specify are consistent with the operating system's IPsec settings.
- If you cannot access Web Image Monitor due to IPsec configuration problems, disable IPsec under [Administrator Tools] on the control panel, and then access Web Image Monitor.

↓ Note

- For details about specifying the IPsec settings using Web Image Monitor, see page 304 "Configuring the IPsec Settings".
- For details about enabling and disabling IPsec using the control panel, see page 251 "Administrator Tools Settings".

Encryption and Authentication by IPsec

IPsec consists of two main functions: the encryption function, which ensures the confidentiality of data, and the authentication function, which verifies the sender of the data and the data's integrity. This machine's IPsec function supports two security protocols: the ESP protocol, which enables both of the IPsec functions at the same time, and the AH protocol, which enables only the authentication function.

ESP Protocol

The ESP protocol provides secure transmission through both encryption and authentication. This protocol does not provide header authentication.

- For successful encryption, both the sender and receiver must specify the same encryption algorithm and encryption key. The encryption algorithm and encryption key are specified automatically.

- For successful authentication, the sender and receiver must specify the same authentication algorithm and authentication key. The authentication algorithm and authentication key are specified automatically.

AH Protocol

The AH protocol provides secure transmission through authentication of packets only, including headers.

- For successful authentication, the sender and receiver must specify the same authentication algorithm and authentication key. The authentication algorithm and authentication key are specified automatically.

AH Protocol + ESP Protocol

When combined, the ESP and AH protocols provide secure transmission through both encryption and authentication. These protocols provide header authentication.

- For successful encryption, both the sender and receiver must specify the same encryption algorithm and encryption key. The encryption algorithm and encryption key are specified automatically.
- For successful authentication, the sender and receiver must specify the same authentication algorithm and authentication key. The authentication algorithm and authentication key are specified automatically.

Note

- Some operating systems use the term "Compliance" in place of "Authentication".

Security Association

This machine uses encryption key exchange as the key setting method. With this method, agreements such as the IPsec algorithm and key must be specified for both sender and receiver. Such agreements form what is known as an SA (Security Association). IPsec communication is possible only if the receiver's and sender's SA settings are identical.

The SA settings are auto configured on both parties' machines. However, before the IPsec SA can be established, the ISAKMP SA (Phase 1) settings must be auto configured. When this is done, the IPsec SA (Phase 2) settings, which allow actual IPsec transmission, will be auto configured.

Also, for further security, the SA can be periodically auto updated by applying a validity period (time limit) for its settings. This machine only supports IKEv1 for encryption key exchange.

Multiple settings can be configured in the SA.

Settings 1-10

You can configure ten separate sets of SA details (such as different shared keys and IPsec algorithms).

IPsec policies are searched through one by one, starting at [No.1].

Encryption Key Exchange Settings Configuration Flow

This section explains the procedure for specifying encryption key exchange settings.

Machine	PC
1. Set the IPsec settings on Web Image Monitor.	1. Set the same IPsec settings as the machine on PC.
2. Enable IPsec settings.	2. Enable IPsec settings.
3. Confirm IPsec transmission.	

Note

- After configuring IPsec, you can use "ping" command to check if the connection is established correctly. Because the response is slow during initial key exchange, it may take some time to confirm that transmission has been established.
- If you cannot access Web Image Monitor due to IPsec configuration problems, disable IPsec under [Administrator Tools] on the control panel, and then access Web Image Monitor.
- For details about disabling IPsec using the control panel, see page 251 "Administrator Tools Settings".

Specifying Encryption Key Exchange Settings

Important

- This function is available only when an administrator password is specified.
1. Start the web browser and access the machine by entering its IP address.
 2. Click [IPsec Settings].
 3. Click the [IPsec Policy List] tab.
 4. Select the number of the setting you want to modify in the list, and then click [Change].
 5. Modify the IPsec related settings as necessary.
 6. Enter the administrator password, and then click [Apply].
 7. Click the [IPsec Global Settings] tab, and then select [Active] in [IPsec Function].
 8. If necessary, specify [Default Policy], [Broadcast and Multicast Bypass], and [All ICMP Bypass] also.
 9. Enter the administrator password, and then click [Apply].

Note

- An administrator password can be specified in the [Administrator] tab.

Specifying IPsec Settings on the Computer

Specify exactly the same settings for IPsec SA settings on your computer as are specified for the IPsec Settings on the machine. Setting methods differ according to the computer's operating system. The following procedure is based on Windows 10 in an IPv4 environment as an example.

1. On the [Start] menu, click [Control Panel], [System and Security], and then click [Administrative Tools].
2. Double-click [Local Security Policy], and then click [IP Security Policies on Local Computer].
3. In the "Action" menu, click [Create IP Security Policy...].

The IP Security Policy Wizard appears.

4. Click [Next].
5. Enter a security policy name in "Name", and then click [Next].
6. Clear the "Activate the default response rule" check box, and then click [Next].
7. Select "Edit properties", and then click [Finish].
8. In the "General" tab, click [Settings...].
9. In "Authenticate and generate a new key after every", enter the same validity period (in minutes) that is specified on the machine in [IKE Life Time], and then click [Methods...].
10. Confirm that the Encryption Algorithm ("Encryption"), Hash Algorithm ("Integrity"), and IKE Diffie-Hellman Group ("Diffie-Hellman Group") settings in "Security method preference order" all match those specified on the machine in [IKE Settings].

If the settings are not displayed, click [Add...].

11. Click [OK] twice.
12. Click [Add...] in the "Rules" tab.
13. Click [Next].
14. Select "This rule does not specify a tunnel", and then click [Next].
15. Select the type of network for IPsec, and then click [Next].
16. Click [Add...] in the IP Filter List.
17. In [Name], enter an IP Filter name, and then click [Add...].

The IP Filter Wizard appears.

18. Click [Next].

19. In [Description:], enter a name or a detailed explanation of the IP filter, and then click [Next].

You may click [Next] and proceed to the next step without entering any information in this field.

20. Select "My IP Address" in "Source address", and then click [Next].
21. Select "A specific IP Address or Subnet" in "Destination address", enter the machine's IP address, and then click [Next].
22. For the IPsec protocol type, select "Any", and then click [Next].
23. Click [Finish], and then click [OK].
24. Select the IP filter that you have just created, and then click [Next].
25. Click [Add...] in the Filter Action.

The Filter Action Wizard appears.

26. Click [Next].
27. In [Name], enter a Filter Action name, and then click [Next].
28. Select "Negotiate security", and then click [Next].
29. Select one of options for computers allowed to communicate with, and then click [Next].
30. Select "Custom" and click [Settings...].
31. When [ESP] is selected for the machine in [Security Protocol] under [IPsec Settings], select [Data integrity and encryption (ESP)], and configure the following settings:

Set the value of [Integrity algorithm] to the same value as the [Authentication Algorithm for ESP] specified on the machine.

Set the value of [Encryption algorithm] to the same value as the [Encryption Algorithm for ESP] specified on the machine.

32. When [AH] is selected for the machine in [Security Protocol] under [IPsec Settings], select [Data and address integrity without encryption (AH)], and configure the following settings:

Set the value of [Integrity algorithm] to the same value as the [Authentication Algorithm for AH] specified on the machine.

Clear the [Data integrity and encryption (ESP)] check box.

33. When [ESP&AH] is selected for the machine in [Security Protocol] under [IPsec Settings], select [Data and address integrity without encryption (AH)], and configure the following settings:

Set the value of [Integrity algorithm] under [Data and address integrity without encryption (AH)] to the same value as [Authentication Algorithm for AH] specified on the machine.

Set the value of [Encryption algorithm] under [Data integrity and encryption (ESP)] to the same value as [Encryption Algorithm for ESP] specified on the machine.

34. In the **Session key settings**, select **"Generate a new key every"**, and enter the same validity period (in **[Seconds]** or **[Kbytes]**) as that specified for **[Life Time]** on the machine.
35. Click **[OK]**, and then click **[Next]**.
36. Click **[Finish]**.

If you are using IPv6, you must repeat this procedure from Step 12 and specify ICMPv6 as an exception. When you reach Step 22, select **[58]** as the protocol number for the "Other" target protocol type, and then set **[Negotiate security]** to **[Permit]**.

37. Select the filter action that you have just created, and then click **[Next]**.
38. Select one of options for an authentication method, and then click **[Next]**.
39. Click **[Finish]**, and then click **[OK]** twice.

The new IP security policy (IPsec settings) is specified.

40. Click **[IP Security Policies on Local Computer]**.
41. Select the security policy that you have just created, right click on it, and then click **[Assign]**.

IPsec settings on the computer are enabled.

↓ Note

- To disable the computer's IPsec settings, select the security policy, right click, and then click **[Unassign]**.

Enabling and Disabling IPsec Using the Control Panel

★ Important

- This function is available only when an administrator password is specified.
1. Press the **[Setting]** icon on the **[Home]** screen.
 2. Press **[Administrator Tools]**.
 3. If you are requested to enter a password, enter the password using the number keys, and then press **[OK]**.

You can display the software keyboard by double tapping the entry area on the display.

A password for accessing the **[Network Settings]** menu can be specified in **[Admin. Tools Lock]** under **[Administrator Tools]** menu.

4. Press **[IPSec]**.
5. Press **[Active]** or **[Inactive]**.

↓ Note

- A password for accessing the **[Administrator Tools]** menu can be specified in **[Admin. Tools Lock]**. For details about **[Admin. Tools Lock]**, see page 251 "Administrator Tools Settings".

- You can press [Exit] to exit to the previous level of the menu tree.

Notes About the Toner

- Proper operation cannot be guaranteed if any third-party toner is used.
- Depending on printing conditions, there are cases where the printer cannot print the number of sheets indicated in the specifications.
- Replace the print cartridge if the printed image suddenly becomes pale or blurred.
- When operating the machine for the first time, use the print cartridge supplied with this machine. If this cartridge is not initially used, the following problems may occur:
 - "Replace Required Soon:" "Print Cartridge (XX)" will be displayed before the toner runs out.
 - "Replacement Required:" "Print Cartridge (XX)" will be displayed when the toner runs out, but instead the printed image suddenly becomes pale or blurred.
- The lifetime of the photo conductor, which is built into the print cartridge, is taken into account in displaying "Replace Required Soon:" "Print Cartridge (XX)". If the photo conductor stops working before the toner runs out, "Replace Required Soon:" "Print Cartridge (XX)" may be displayed.

Specifications of the Machine

This section lists the machine's specifications.

Note

- We have obtained each author's permission for the use of applications including open-source software applications. For details about the copyright information for these software applications, see "OSS.pdf" on the CD-ROM supplied with the machine.

General Function Specifications

Item	Description
Configuration	Desktop
Print process	Laser electrostatic transfer
Maximum paper size for scanning using the exposure glass	A4, Letter (8 ¹ / ₂ × 11 inches)
Maximum paper size for scanning using the ADF	Legal (8 ¹ / ₂ × 14 inches)
Maximum paper size for printing	Legal (8 ¹ / ₂ × 14 inches)
Warm-up time (23 °C, 71.6 °F)	20 seconds or less
Paper sizes	For details, see page 62 "Supported Paper".
Paper type	For details, see page 62 "Supported Paper".
Paper output capacity (80 g/m ² , 20 lb)	150 sheets
Paper input capacity (80 g/m ² , 20 lb)	<ul style="list-style-type: none"> Tray 1 250 sheets Tray 2 500 sheets Bypass tray 1 sheet
ADF capacity (80 g/m ² , 20 lb)	50 sheets
Memory	256MB

Item	Description
Power requirements	<p> Region A</p> <p>220-240 V, 6 A, 50/60 Hz</p> <p> Region B</p> <p>120-127 V, 11 A, 60 Hz</p>
<p>Power consumption  Region A</p> <p>The power level when the main switch is turned off and the power cord is plugged into an outlet: 1 W or less</p>	<ul style="list-style-type: none"> • Maximum 1300 W or less • Ready 35.4 W • During printing Color: 444 W B&W: 422 W
<p>Power consumption  Region B</p> <p>The power level when the main switch is turned off and the power cord is plugged into an outlet: 1 W or less</p>	<ul style="list-style-type: none"> • Maximum 1300 W or less • Ready 34.5 W • During printing Color: 469 W B&W: 428 W
Noise emission	<ul style="list-style-type: none"> • Sound power level Stand-by: 29.8 dB (A) During printing: Color: 64.4 dB (A) B&W: 63.6 dB (A) • Sound pressure level Stand-by: 20.4 dB (A) During printing: Color: 53.5 dB (A) B&W: 53.0 dB (A)
Machine dimensions (Width × Depth × Height)	420 × 493 × 473 mm (16.6 × 19.5 × 18.6 inches)

Item	Description
Weight (machine body with consumables)	30 kg (67 lb.) or less

Note



- Sound power level and sound pressure level are actual values measured in accordance with ISO 7779.
- Sound pressure level is measured from the position of the bystander.

Printer Function Specifications

Item	Description
Printing speed	Black and white: 25 pages per minute (Simplex/Letter), 13.5 pages per minute (Duplex/Letter) Color: 25 pages per minute (Simplex/Letter), 13.5 pages per minute (Duplex/Letter)
Resolution	600 × 600 dpi
First print speed	10 seconds or less
Interface	<ul style="list-style-type: none"> • Ethernet (10BASE-T, 100BASE-TX) • USB 2.0 • Wi-Fi • USB2.0 Host
Printer language	PCL6, PCL5c, PostScript3
Fonts (PCL6, PCL5c, PostScript3)	80 fonts

Copier Function Specifications

Item	Description
Maximum resolution (scanning and printing)	<ul style="list-style-type: none"> • Exposure glass Scanning: 600 × 600 dpi Printing: 600 × 600 dpi • ADF Scanning: 300 × 600 dpi Printing: 600 × 600 dpi
First copy speed (A4, at 23 °C, 71.6 °F)	<ul style="list-style-type: none"> • Black and white: 15 seconds or less • Color: 19 seconds or less
Gradation	<p>Scanning: 256 levels</p> <p>Printing: Four-value</p>
Multiple copy speed (Countries other than European countries)	<ul style="list-style-type: none"> • When copying multiple simplex originals (simplex printing) <ul style="list-style-type: none"> • 25 pages per minute (A4) • 25 pages per minute (Letter (8¹/₂ × 11 inches)) • When copying multiple copies of simplex originals one by one (simplex printing) <ul style="list-style-type: none"> • Black and white: 20 pages per minute • Full Color: 12 pages per minute • When copying multiple copies of two-sided originals one by one (duplex scanning, duplex printing) <ul style="list-style-type: none"> • Black and white: 13.5 pages per minute • Full Color: 13.5 pages per minute

Item	Description
Reproduction ratio	<ul style="list-style-type: none"> Fixed ratio <ul style="list-style-type: none">  Region A 50%, 71%, 82%, 93%, 122%, 141%, 200%, 400%  Region B 50%, 65%, 78%, 93%, 129%, 155%, 200%, 400% Zoom ratio 25% to 400%
Copy quantity	99

Scanner Function Specifications

Item	Description
Maximum scanning area (horizontal × vertical)	<ul style="list-style-type: none"> Exposure glass 216 × 297 mm (8.5 × 11.7 inches) ADF 216 × 356 mm (8.5 × 14 inches)
Maximum resolution when scanning from the control panel (Scan to E-mail, Scan to FTP, Scan to Folder, Scan to USB)	<ul style="list-style-type: none"> Exposure glass 600 × 600 dpi ADF 300 × 300 dpi
Maximum resolution when scanning from a computer (TWAIN)	<ul style="list-style-type: none"> Exposure glass 19200 × 19200 dpi ADF 600 × 600 dpi
Maximum resolution when scanning from a computer (WIA)	600 × 600 dpi
Gradation	<ul style="list-style-type: none"> Input: 16 bit color processing Output: 8 bit color processing

Item	Description
Scanning time	<ul style="list-style-type: none"> Black and white: 5 seconds or less Color: 10 seconds or less (A4/600 dpi/Compressed) Not including transfer time.
ADF throughput	<ul style="list-style-type: none"> Black and white: 20 image per minute (300 × 600 dpi) Full Color: 12 image per minute (300 × 600 dpi)
Interface	Ethernet (10BASE-T, 100BASE-TX), USB 2.0, Wi-Fi
Sendable file formats	TIFF, JPEG, PDF
Address book	Maximum 100 items Number of redials: 1

Fax Function Specifications

Fax transmission and reception

Item	Description
Access line	<ul style="list-style-type: none"> Public switched telephone networks (PSTN) Private branch exchange (PBX)
Transmission mode	ITU-T Group 3 (G3)
Scan line density	<ul style="list-style-type: none"> 8 dots per mm × 3.85 line per mm (200 × 100 dpi) 8 dots per mm × 7.7 line per mm (200 × 200 dpi)
Transmission time	3 seconds (8 dots per mm × 3.85 line per mm, 33.6 kbps, MMR, ITU-T # 1 chart)
Transfer rate	33.6 kbps to 2400 bps (auto shift down system)
Data compression methods	MH, MR, MMR, JBIG

Item	Description
Memory capacity	100 sheets (8 dots per mm × 3.85 line per mm, MMR, ITU-T # 1 chart)
Address book	<ul style="list-style-type: none"> • Speed dial 200 items • Quick dial 20 items • Number of redials for Fax 1

Internet Fax transmission and reception

Item	Description
Interface	Ethernet (10BASE-T, 100BASE-TX), Wi-Fi
Communication protocols	<ul style="list-style-type: none"> • Transmission SMTP, TCP/IP • Reception POP3, TCP/IP
Transmission function	E-mail
E-mail format	Single/Multi-part, MIME Conversion Attached file forms (transmission): TIFF-S (MH encoding) Attached file forms (reception): TIFF-S/TIFF-F (MH/MR/MMR encoding)
Authentication method	SMTP-AUTH, POP before SMTP, A-POP
Original size	A4 (Length is up to 356 mm)
Scan line density	8 dots per mm × 3.85 line per mm (200 × 100 dpi) 8 dots per mm × 7.7 line per mm (200 × 200 dpi)

Item	Description
Destination machine specifications	<ul style="list-style-type: none"> • Communication protocols <ul style="list-style-type: none"> • Transmission SMTP, TCP/IP • Reception POP3, TCP/IP • E-mail format <ul style="list-style-type: none"> • Format MIME, Base64 • Content-Type Image/tiff Multipart/mixed (text/plain, Image/tiff (attached file forms)) • Data format <ul style="list-style-type: none"> • Profile TIFF-S • Encoding MH • Original size A4 • Resolution (dpi) 200 × 100, 200 × 200

Paper Feed Unit TK1220

Paper capacity

500 sheets

Paper size

For details, see page 62 "Supported Paper".

Dimensions (Width × Depth × Height)

400 × 450 × 127 mm (15.8 × 17.8 × 5 inches)

Paper weight

For details, see page 62 "Supported Paper".

Weight

Less than 4 kg (8.9 lb.)

Consumables

CAUTION

- Our products are engineered to meet high standards of quality and functionality, and we recommend that you use only the expendable supplies available at an authorized dealer.

Print Cartridge

Print cartridge	Average printable number of pages per cartridge ^{*1}
Black	M C250FWB: 2,300 pages M C250FW: 6,900 pages
Cyan	M C250FWB: 2,300 pages M C250FW: 6,300 pages
Magenta	M C250FWB: 2,300 pages M C250FW: 6,300 pages
Yellow	M C250FWB: 2,300 pages M C250FW: 6,300 pages

*1 The printable number of pages is based on pages that are compliant with ISO/IEC 19798 and the image density set as the factory default. ISO/IEC 19798 is an international standard on measurement of printable pages, set by the International Organization for Standardization.

Note

- For information about consumables, see our website.
- If print cartridges are not changed when necessary, printing will become impossible. For easy replacement, we recommend you purchase and store extra print cartridges.
- The actual number of printable pages varies depending on the image volume and density, number of pages printed at a time, paper type and paper size used, and environmental conditions such as temperature and humidity.
- Print cartridges may need to be changed sooner than indicated above due to deterioration over the period of use.
- Print cartridges (consumables) are not covered by warranty. However, if there is a problem, contact the store where they were purchased.
- When you first use this machine, use the print cartridges packaged with the machine.
- The supplied print cartridges are good for approximately 1,000 pages.

- This machine routinely performs cleaning and uses toner during this operation to maintain quality.
- To prevent a cleaning malfunction, you may need to replace a print cartridge even if it is not empty.

Waste Toner Bottle

Name	Average printable number of pages per cartridge ^{*1}
Waste Toner Bottle SP C220	25,000 pages

*1 A4/Letter 5% test chart, 3 pages per job, printing in 50% black and white/color.

↓ Note

- The actual number of printable pages varies depending on the image volume and density, number of pages printed at a time, paper type and paper size used, and environmental conditions such as temperature and humidity.
- If the waste toner bottle is not changed when necessary, printing will become impossible. For easy replacement, we recommend you purchase and store extra waste toner bottles.

Information for This Machine

User Information on Electrical & Electronic Equipment Region **A** (mainly Europe and Asia)

Users in the countries where this symbol shown in this section has been specified in national law on collection and treatment of E-waste

Our Products contain high quality components and are designed to facilitate recycling.

Our products or product packaging are marked with the symbol below.



The symbol indicates that the product must not be treated as municipal waste. It must be disposed of separately via the appropriate return and collection systems available. By following these instructions you ensure that this product is treated correctly and help to reduce potential impacts on the environment and human health, which could otherwise result from inappropriate handling. Recycling of products helps to conserve natural resources and protect the environment.

For more detailed information on collection and recycling systems for this product, please contact the shop where you purchased it, your local dealer or sales/service representatives.

All Other Users

If you wish to discard this product, please contact your local authorities, the shop where you bought this product, your local dealer or sales/service representatives.

For Users in India

This product including components, consumables, parts and spares complies with the "India E-waste Rule" and prohibits use of lead, mercury, hexavalent chromium, polybrominated biphenyls or polybrominated diphenyl ethers in concentrations exceeding 0.1 weight % and 0.01 weight % for cadmium, except for the exemptions set in the Rule.

For Turkey only

AEEE Yönetmeliğine Uygundur.

Bu sistem sarf malzemeleri ve yedek parçaları da dahil olmak üzere AEEE Yönetmeliğine Uygundur.

Üretici:

Ricoh Company, Ltd.

3-6, Nakamagome 1-chome,

Ohta-ku, Tokyo 143-8555 Japan

+81-3-3777-8111 (English only/Sadece İngilizce)

Note for the Battery and/or Accumulator Symbol (For EU countries only)



In accordance with the Battery Directive 2006/66/EC Article 20 Information for end-users Annex II, the above symbol is printed on batteries and accumulators.

This symbol means that in the European Union, used batteries and accumulators should be disposed of separately from your household waste.

In the EU, there are separate collection systems for not only used electrical and electronic products but also batteries and accumulators.

Please dispose of them correctly at your local community waste collection/recycling centre.

Environmental Advice for Users Region A (mainly Europe)

Users in the EU, Switzerland and Norway

Consumables yield

Please refer to either the User's Manual for this information or the packaging of the consumable.

Recycled paper

The machine can use recycled paper which is produced in accordance with European standard EN 12281:2002 or DIN 19309. For products using EP printing technology, the machine can print on 64 g/m² paper, which contains less raw materials and represents a significant resource reduction.

Duplex printing (if applicable)

Duplex printing enables both sides of a sheet of paper to be used. This saves paper and reduces the size of printed documents so that fewer sheets are used. We recommend that this feature is enabled whenever you print.

Toner and ink cartridge return program

Toner and ink cartridge for recycling will be accepted free of charge from users in accordance with local regulations.

For details about the return program, please refer to the Web page below or consult your service person.

<https://www.rioh-return.com/>

Energy efficiency

The amount of electricity a machine consumes depends as much on its specifications as it does on the way you use it. The machine is designed to allow you to reduce electricity costs by switching to Ready mode after it prints the last page. If required, it can immediately print again from this mode. If no additional prints are required and a specified period of time passes, the device switches to an energy saving mode.

In these modes, the machine consumes less power (watts). If the machine is to print again, it needs a little longer to return from an energy saving mode than from Ready mode.

For maximum energy savings, we recommend that the default setting for power management is used.

Note to Users EU Countries

Model Name: M C250FW, M C250FWB

Manufacturer:

Ricoh Co., Ltd.

3-6 Nakamagome 1-chome, Ohta-ku, Tokyo. 143-8555, Japan

Importer:

Ricoh Europe SCM B.V.

Blankenweg 24, 4612 RC Bergen op Zoom, The Netherlands

Declaration of Conformity

Notice to Users in EEA Countries

This product complies with the essential requirements and provisions of Directive 2014/53/EU.

The CE Declaration of Conformity is available by accessing the URL:

https://www.rioh.com/products/ce_doc2/

and selecting the product applicable.

Operating frequency band: 2412-2462 MHz, 5150-5350MHz

RF Output Power: 17dBm - 802.11b / 15dBm - 802.11g / 13dBm - 802.11a / 13dBm - 802.11n / 11dBm - 802.11ac

Operating frequency band: 13.56Mhz

Maximum radio-frequency power: less than 42dBµA/m (at 10m)

* Maximum radio-frequency power is depended on power value of reader/writer device.

Outdoor use of the 5GHz band is prohibited.

As this equipment with the radiating part is not intended to be used in close proximity to the human body, it is recommended to use at least 20cm apart from the user.

NOTES TO USERS REGARDING FACSIMILE UNIT (NEW ZEALAND)

The grant of a Telepermit for any item of terminal equipment indicates only that Telecom has accepted that the item complies with minimum conditions for connection to its network. It indicates no endorsement of the product by Telecom, nor does it provide any sort of warranty. Above all, it provides no assurance that any item will work correctly in all respects with another item of Telepermitted equipment of a different make or model, nor does it imply that any product is compatible with all of Telecom's network services.

This equipment is not capable, under all operating conditions, of correct operation at the higher speeds for which it is designed. Telecom will accept no responsibility should difficulties arise in such circumstances.

Devices connected to the telephone port may lose their memory if this fax machine is on line for extended periods. To prevent this, such devices should have the facility for battery or similar backup of memory.

This device may be subject to ringing or bell tinkle when certain other devices are connected to the same line. If this occurs, the problem should not be referred to the Telecom Faults Service.

This equipment should not be used under any circumstances that may constitute a nuisance to other Telecom customers.

Telepermitted equipment only may be connected to the auxiliary telephone port. The auxiliary telephone port is not specifically designed for 3-wire connected equipment that may not respond to incoming ringing when attached to this port.

Notes to users in the state of California (Notes to Users in USA)

Perchlorate Material - special handling may apply. See: www.dtsc.ca.gov/hazardouswaste/perchlorate

Notes to users in the United States of America

FCC Rules

Note:

This equipment has been tested and found to comply with the limits for a Class B digital device, pursuant to Part 15 of the FCC Rules. These limits are designed to provide reasonable protection against harmful interference in a residential installation. This equipment generates, uses and can radiate radio frequency energy and, if not installed and used in accordance with the instructions, may cause harmful interference to radio communications. However, there is no guarantee that interference will not occur in a particular installation. If this equipment does cause harmful interference to radio or television reception, which can be determined by turning the equipment off and on, the user is encouraged to try to correct the interference by one or more of the following measures:

- Reorient or relocate the receiving antenna.
- Increase the separation between the equipment and receiver.
- Connect the equipment into an outlet on a circuit different from that to which the receiver is connected.
- Consult the dealer or an experienced radio /TV technician for help.

Caution:

Changes or modifications not expressly approved by the party responsible for compliance could void the user's authority to operate the equipment.

This transmitter must not be co-located or operated in conjunction with any other antenna or transmitter.

Frequency Tolerance: ± 12.5 ppm

Compliance with FCC requirement 15.407(c)

Data transmission is always initiated by software, which is the passed down through the MAC, through the digital and analog baseband, and finally to the RF chip. Several special packets are initiated by the MAC. These are the only ways the digital baseband portion will turn on the RF transmitter, which it then turns off at the end of the packet. Therefore, the transmitter will be on only while one of the aforementioned packets is being transmitted. In other words, this device automatically discontinues transmission in case of either absence of information to transmit or operational failure.

Federal Communication Commission (FCC) Radiation Exposure Statement

This EUT is compliance with SAR for general population/uncontrolled exposure limits in ANSI/IEEE C95.1-1999 and had been tested in accordance with the measurement methods and procedures specified in OET Bulletin 65 Supplement C. This equipment should be installed and operated with minimum distance 0.5cm between the radiator & your body.

Supplier's Declaration of Conformity

This device complies with Part 15 of the FCC Rules.

Operation is subject to the following two conditions:

- (1) This device may not cause harmful interference, and
- (2) this device must accept any interference received, including interference that may cause undesired operation.

Responsible party: Ricoh USA, Inc.

Address: 70 Valley Stream Parkway Malvern, Pennsylvania 19355

Telephone number: 610-296-8000

Product Name: Multifunction Digital Product(Copier/Printer/Scanner)

Model Number: M C250FW, M C250FWB

Part 68 of the FCC Rules regarding Facsimile Unit

1. This equipment complies with Part 68 of the FCC rules and requirements adopted by the ACTA. On the cover of this equipment is a label that contains, among other information, a product identifier in the format US:AAAEQ##TXXXXX. If requested, this number must be provided to the telephone company.
2. This equipment uses the RJ11C USOC jack.
3. A plug and jack used to connect this equipment to the premises wiring and telephone network must comply with the applicable FCC Part 68 rules and requirements adopted by the ACTA. A compliant telephone cord and modular plug is provided with this product. It is designed to be connected to a compatible modular jack that is also compliant. See installation instructions for detail.
4. The REN is used to determine the number of devices that may be connected to a telephone line. Excessive RENs on a telephone line may result in the devices not ringing in response to an incoming call. In most but not all areas, the sum of RENs should not exceed five (5.0). To be certain of the number of devices that may be connected to a line, as determined by the total RENs, contact the local telephone company. The REN for this product is part of the product identifier that has the format US:AAAEQ##TXXXXX. The digits represented by ## are the REN without a decimal point (e.g., 03 is a REN of 0.3).
5. If this equipment causes harm to the telephone network, the telephone company will notify you in advance that temporary discontinuance of service may be required. But if advance notice is not practical, the telephone company will notify the customer as soon as possible. Also, you will be advised of your right to file a complaint with the FCC if you believe it is necessary.
6. The telephone company may make changes in its facilities, equipment, operations or procedures that could affect the operation of the equipment. If this happens the telephone company will provide advance notice in order for you to make necessary modifications to maintain uninterrupted service.
7. If trouble is experienced with this equipment, for repair or warranty information, please contact Ricoh USA, Inc. Customer Support Department at 1-888-456-6457. If this device is causing

problems with your telephone network, the telephone company may request that you disconnect the equipment until the problem is resolved.

8. In the event of operation problems (document jam, copy jam, communication error indication), see the manual provided with this machine for instruction on resolving the problem.
9. Connection to party line service is subject to state tariffs. Contact the state public utility commission, public service commission or corporation commission for information.
10. If your home has specially wired alarm equipment connected to the telephone line, ensure the installation of this equipment does not disable your alarm equipment. If you have questions about what will disable alarm equipment, consult your telephone company or a qualified installer.

WHEN PROGRAMMING EMERGENCY NUMBERS AND/OR MAKING TEST CALLS TO EMERGENCY NUMBERS:

1. Remain on the line and briefly explain to the dispatcher the reason for the call before hanging up.
2. Perform such activities in the off-peak hours, such as early morning hours or late evenings.

The Telephone Consumer Protection Act of 1991 makes it unlawful for any person to use a computer or other electronic device, including FAX machines, to send any message unless such message clearly contains in a margin at the top or bottom of each transmitted page or on the first page of the transmission, the date and time it is sent and an identification of the business or other entity, or other individual sending the message and the telephone number of the sending machine or such business, other entity, or individual. (The telephone number provided may not be a 900 number or any other number for which charges exceed local or long-distance transmission charges.)

In order to program this information into your FAX machine, you should complete the following steps: Follow the FAX HEADER programming procedure in the Programming chapter of the operating instructions to enter the business identification and telephone number of the terminal or business. This information is transmitted with your document by the FAX HEADER feature. In addition to the information, be sure to program the date and time into your machine.

Notes to Canadian Users of Wireless Devices

This device complies with Industry Canada's licence-exempt RSSs.

Operation is subject to the following two conditions:

- (1) This device may not cause interference; and
- (2) This device must accept any interference, including interference that may cause undesired operation of the device.

Federal Communication Commission (FCC) Radiation Exposure Statement

This EUT is compliance with SAR for general population/uncontrolled exposure limits in ANSI/IEEE C95.1-1999 and had been tested in accordance with the measurement methods and procedures

specified in OET Bulletin 65 Supplement C. This equipment should be installed and operated with minimum distance 0.5cm between the radiator & your body.

5150-5250 MHz band is restricted to indoor operation only.

5250-5350 MHz band is restricted to indoor operation only.

Compliance with ISED requirement RSS-247 6.4 a) Data transmission is always initiated by software, which is the passed down through the MAC, through the digital and analog baseband, and finally to the RF chip. Several special packets are initiated by the MAC. These are the only ways the digital baseband portion will turn on the RF transmitter, which it then turns off at the end of the packet. Therefore, the transmitter will be on only while one of the aforementioned packets is being transmitted. In other words, this device automatically discontinue transmission in case of either absence of information to transmit or operational failure.

Remarques à l'attention des utilisateurs canadiens d'appareils sans fil

Le présent appareil est conforme aux CNR d'Industrie Canada applicables aux appareils radio exempts de licence.

L'exploitation est autorisée aux deux conditions suivantes :

- (1) l'appareil ne doit pas produire de brouillage, et
- (2) l'utilisateur de l'appareil doit accepter tout brouillage radioélectrique subi, même si le brouillage est susceptible d'en compromettre le fonctionnement.

Cet EUT est conforme à la norme SAR pour la population générale / limites d'exposition non contrôlées selon la norme ANSI / IEEE C95.1-1999 et a été testé conformément aux méthodes et procédures de mesure spécifiées dans le CNR-102. Cet équipement doit être installé et utilisé à une distance minimale. 0.5 cm entre le radiateur et votre corps.

La bande 5150-5250 MHz est restreinte à une utilisation à l'intérieur seulement.

La bande 5250-5350 MHz est restreinte à une utilisation à l'intérieur seulement.

Conformité à la norme CNR-247 6.4 a) La transmission des données est toujours initiée par le logiciel, puis les données sont transmises par l'intermédiaire du MAC, par la bande de base numérique et analogique et, enfin, à la puce RF. Plusieurs paquets spéciaux sont initiés par le MAC. Ce sont les seuls moyens pour qu'une partie de la bande de base numérique active l'émetteur RF, puis désactive celui-ci à la fin du paquet. En conséquence, l'émetteur reste uniquement activé lors de la transmission d'un des paquets susmentionnés. En d'autres termes, ce dispositif interrompt automatiquement toute transmission en cas d'absence d'information à transmettre ou de défaillance.

Notes to Canadian Users regarding Facsimile Unit

This product meets the applicable Innovation, Science and Economic Development Canada technical specifications.

The Ringer Equivalence Number (REN) indicates the maximum number of devices allowed to be connected to a telephone interface. The termination of an interface may consist of any combination of devices subject only to the requirement that the sum of the RENs of all the devices not exceed five.

Remarques à l'attention des utilisateurs canadiens

Le présent produit est conforme aux spécifications techniques applicables d'Innovation, Sciences et Développement économique Canada.

L'indice d'équivalence de la sonnerie (IES) sert à indiquer le nombre maximal de dispositifs qui peuvent être raccordés à une interface téléphonique. La terminaison d'une interface peut consister en une combinaison quelconque de dispositifs, à la seule condition que la somme des IES de tous les dispositifs n'excède pas cinq.

ENERGY STAR Program Region B

ENERGY STAR® Program Requirements for Imaging Equipment



The ENERGY STAR® Program Requirements for Imaging Equipment encourage energy conservation by promoting energy efficient computers and other office equipment.

The program backs the development and dissemination of products that feature energy saving functions.

It is an open program in which manufacturers participate voluntarily.

Targeted products are computers, monitors, printers, facsimiles, copiers, scanners, and multifunction devices. Energy Star standards and logos are internationally uniform.

Saving Energy

This machine is equipped with the following Energy Saver modes: Energy Saver mode 1 and Energy Saver mode 2. If the machine has been idle for a certain period of time, the machine automatically enters Energy Saver mode.

The machine recovers from Energy Saver mode when it receives a print job, prints a received fax, or when any key is pressed.

Energy Saver mode 1





The machine enters Energy Saver mode 1 if the machine has been idle for about 30 seconds. It takes less time to recover from Energy Saver mode 1 than from power-off state or Energy Saver mode 2, but power consumption is higher in Energy Saver mode 1 than in Energy Saver mode 2.

Energy Saver mode 2

The machine enters Energy Saver mode 2 after the period of time specified for this setting is passed. Power consumption is lower in Energy Saver mode 2 than in Energy Saver mode 1, but it takes longer to recover from Energy Saver mode 2 than from Energy Saver mode 1.

After printing in Energy Saver mode 2, the power is turned off without waiting for 1 minute.

Specifications

Energy Saver mode 1	Power Consumption ^{*1}	 Region A 26.5 W  Region B 26.9 W
	Default Time	30 seconds
	Recovery Time ^{*1}	10 seconds or less
Energy Saver mode 2	Power Consumption ^{*1}	 Region A 0.74 W  Region B 0.70 W
	Default Time	1 minute
	Recovery Time ^{*1}	12 seconds
Duplex Function ^{*2}		Standard

*1 Recovery time and power consumption may differ depending on the conditions and environment of the machine.

*2 Achieves ENERGY STAR energy savings; product fully qualifies when packaged with (or used with) a duplex tray and the duplex function is enabled as an option.

For details about Energy Saver modes, see page 251 "Administrator Tools Settings".

Note

- If the machine is in Energy Saver mode for 24 hours continuously, the machine automatically returns to normal state and performs self-maintenance.
-  **Region A** (mainly Europe)

The power is automatically switched off if the machine is left idle in standby mode for 2 hours.

Trademarks

Adobe and Acrobat are either registered trademarks or trademarks of Adobe Systems Incorporated in the United States and/or other countries.

Android, Google Chrome, and Google Play are trademarks or registered trademarks of Google LLC.

OS X, macOS, TrueType, App Store, and Safari are trademarks of Apple Inc., registered in the U.S. and other countries.

Firefox® is a registered trademark of the Mozilla Foundation.

IOS is a trademark or registered trademark of Cisco in the U.S. and other countries and is used under license.

Java is a registered trademark of Oracle and/or its affiliates.

LINUX® is the registered trademark of Linus Torvalds in the U.S. and other countries.

Microsoft®, Windows®, Windows Server®, and Internet Explorer® are either registered trademarks or trademarks of Microsoft Corporation in the United States and/or other countries.

PCL® is a registered trademark of Hewlett-Packard Company.

QR Code is a registered trademark of DENSO WAVE INCORPORATED in Japan and in other countries.

Red Hat is a registered trademark of Red Hat, Inc.

Wi-Fi® and Wi-Fi Direct® are registered trademarks of Wi-Fi Alliance.

The proper names of Internet Explorer 9, 10 and 11 are as follows:

- Windows® Internet Explorer® 9
- Internet Explorer® 10
- Internet Explorer® 11

The proper name of Edge is Microsoft® Edge™.

The proper names of the Windows operating systems are as follows:

- The product names of Windows 7 are as follows:
 - Microsoft® Windows® 7 Home Premium
 - Microsoft® Windows® 7 Professional
 - Microsoft® Windows® 7 Ultimate
 - Microsoft® Windows® 7 Enterprise
- The product names of Windows 8.1 are as follows:
 - Microsoft® Windows® 8.1
 - Microsoft® Windows® 8.1 Pro
 - Microsoft® Windows® 8.1 Enterprise
- The product names of Windows 10 are as follows:

Microsoft® Windows® 10 Home Premium

Microsoft® Windows® 10 Pro

Microsoft® Windows® 10 Enterprise

Microsoft® Windows® 10 Education

- The product names of Windows Server 2008 are as follows:

Microsoft® Windows Server® 2008 Standard

Microsoft® Windows Server® 2008 Enterprise

- The product names of Windows Server 2008 R2 are as follows:

Microsoft® Windows Server® 2008 R2 Standard

Microsoft® Windows Server® 2008 R2 Enterprise

- The product names of Windows Server 2012 are as follows:

Microsoft® Windows Server® 2012 Foundation

Microsoft® Windows Server® 2012 Essentials

Microsoft® Windows Server® 2012 Standard

- The product names of Windows Server 2012 R2 are as follows:

Microsoft® Windows Server® 2012 R2 Foundation

Microsoft® Windows Server® 2012 R2 Essentials

Microsoft® Windows Server® 2012 R2 Standard

- The product names of Windows Server 2016 are as follows:

Microsoft® Windows Server® 2016 Standard

Microsoft® Windows Server® 2016 Essentials

Other product names used herein are for identification purposes only and might be trademarks of their respective companies. We disclaim any and all rights to those marks.

Microsoft product screen shots reprinted with permission from Microsoft Corporation.

INDEX

@Remote..... 266

A

Address book..... 126, 233
address book (LAN-Fax)..... 198, 201
ADF..... 335
ADF (Auto Document Feeder)..... 78, 335
Administrator password..... 15, 251, 309
Administrator settings..... 309
Administrator Tools settings..... 251
Attaching Paper Feed Unit TK1220..... 25
Authentication..... 399
Authorized reception..... 213, 282
Auto e-mail notification settings..... 296

B

B&W print priority..... 284
Backup settings..... 310
Basic operation..... 135, 215
Broadcast function..... 190
Bypass tray..... 53, 277
Bypass tray setting priority..... 276

C

Canceling a copy..... 103
Canceling a fax..... 197
Canceling a Transmission..... 186
Cleaning..... 325, 326, 328, 331, 334
Community..... 297
Confidential document..... 91
Configuration page..... 259, 308
Configuring Network Settings
 Ethernet..... 391
 Wireless LAN..... 393
Configuring the machine
 Printing the configuration page..... 259
 Using the control panel..... 215
Confirming information
 Printer driver settings..... 85
Consumables..... 416
Control panel..... 22
Copier mode screen..... 100
Copier settings..... 217

Copy

2-sided copy..... 107, 112
Basic operation..... 102
Combine..... 107, 112
Enlarge..... 105
ID Card copy..... 117
Reduce..... 105
Scan settings..... 120
Specifications..... 410
Counter information..... 272
Cover sheet..... 201

D

Date and time settings..... 175, 311
Date setting..... 311
Default settings..... 309
Density..... 168
Disclaimer..... 14
DNS setting..... 295
Duplex..... 274

E

E-mail notification 1..... 296
E-mail notification 2..... 296
Economy Color Prints..... 274
Encryption..... 399
Encryption key exchange..... 401
Energy saver mode..... 312, 426
Entering characters..... 42
Error messages..... 339
Exposure glass..... 334
Extending tray 1..... 51
Exterior..... 17

F

Fax

Fax setting workflows..... 172
LAN-Fax..... 196
Lists/Reports..... 214
Receiving a fax..... 202
Registering destinations..... 176
Sending a fax..... 182
Specifications..... 412
Fax destinations..... 176, 178, 179, 285
Fax journal..... 259
Fax mode screen..... 173

Fax Number confirmation.....	281
Fax only mode.....	205
Fax printing.....	211
Fax received file processing.....	281
Fax settings.....	224
Fax Speed Dial destination list.....	259
Fax TX/RX standby file list.....	308
FAX/TAD mode.....	205
FAX/TEL Auto mode.....	205
FAX/TEL manual mode.....	204
Forwarding.....	208, 209
Fusing Unit.....	324

G

General status.....	293
---------------------	-----

I

I/O timeout.....	284
IKE settings.....	304
Image density.....	120, 193
Immediate transmission.....	182
Interior.....	21
Intermediate transfer unit.....	324
Internet fax.....	206, 299
Internet fax transmission and reception.....	413
Introduction.....	13
IPsec global settings.....	304
IPsec policy settings.....	304
IPsec settings.....	304
IPsec transmission.....	399
IPv6 configuration.....	294
IPv6 environment.....	294

J

Job cancel.....	89
-----------------	----

L

LAN-Fax.....	196
Language.....	270
List of Option.....	15
Lists.....	214, 259, 308
Loading paper.....	48
Locked Print.....	92

M

Machine information.....	275
Maintaining the machine	
Cleaning the machine.....	325, 328, 334, 335
Replacing the print cartridge.....	313
Maintenance page.....	259, 308
mDNS setting.....	294
Memory transmission.....	182
Menu chart.....	216
Messages.....	339
Model-specific information.....	13
Moving.....	337
Multi-access.....	37

N

Network application.....	294
Network print setting.....	294
Network settings.....	261, 293
Network status.....	293
Non-recommended paper.....	72
Notes.....	406

O

On hook dial.....	191
Operation Tools.....	41
Option settings.....	82
Original.....	77
Original type.....	120

P

Page counter.....	272
Paper Feed Unit TK1220.....	25, 414
Paper jam.....	349, 352, 354, 356, 357
Paper mismatch.....	88
Paper recommendations.....	77
Paper settings.....	246
Paper size.....	56
Paper Storage.....	72
Paper tray.....	271
Paper types.....	65
Bond Paper.....	65
Cardstock.....	65
Color Paper.....	65
Envelope.....	65

Label Paper.....	65
Letterhead.....	65
Middle Thick paper.....	65
Plain Paper.....	65
Preprinted Paper.....	65
Prepunched Paper.....	65
Recycled Paper.....	65
Thick Paper 1.....	65
Thick Paper 2.....	65
Thin Paper.....	65

Placing originals.....	76
POP3 settings.....	299

Print	
Basic operation.....	87
Combine.....	81
Duplex.....	81
Printing on envelopes.....	54
Specifications.....	409

Print area.....	73
Print cartridge.....	313, 416
Print counter.....	272
Print functions.....	95
Print output functions.....	96
Print quality functions.....	95
Printer settings.....	242
Priority tray.....	282

Q

Quick Dial destination list.....	259
----------------------------------	-----

R

Reception mode.....	202
Redial function.....	191
Registering information	
Destinations.....	126, 176
E-mail address.....	144
Fax number.....	251
Folder.....	135
FTP server.....	148
Replacing the Fusing Unit and Transfer Rollor..	324
Replacing the intermediate transfer unit.....	324
Reports.....	259, 308
Resend key.....	151
Reset settings.....	309
Resolution.....	169, 194
Restore settings.....	311

Restrict user function.....	287, 291
-----------------------------	----------

S

SA (Security Association).....	400
--------------------------------	-----

Scan	
Registering destinations.....	126
SANE.....	166
Scan settings.....	167
Scan to E-mail.....	144
Scan to Folder.....	135
Scan to FTP.....	148
Scan to USB.....	152
TWAIN.....	159
WIA.....	162

Scan destinations.....	126, 132, 151, 285
------------------------	--------------------

Scan size.....	167
----------------	-----

Scan to E-mail.....	126, 144
---------------------	----------

Scan to Folder.....	126
---------------------	-----

Scan to FTP.....	126, 148
------------------	----------

Scanner destination list.....	259, 308
-------------------------------	----------

Scanner function.....	411
-----------------------	-----

Scanner journal.....	259
----------------------	-----

Scanner mode screen.....	124
--------------------------	-----

Scanner send setting.....	294
---------------------------	-----

Scanner settings.....	222
-----------------------	-----

Select paper.....	280
-------------------	-----

Select paper tray.....	280
------------------------	-----

Sending a fax.....	184
--------------------	-----

Set date.....	311
---------------	-----

Set time.....	311
---------------	-----

SMTP settings.....	298
--------------------	-----

SNMP settings.....	297
--------------------	-----

Sound volume adjustment.....	276
------------------------------	-----

Special senders.....	212
----------------------	-----

Specifications.....	407, 409, 410, 411, 412
---------------------	-------------------------

Specifying the paper type and paper size... 59, 60	
--	--

Speed Dial.....	178, 179, 189
-----------------	---------------

Standby file list.....	259
------------------------	-----

Status information.....	271
-------------------------	-----

Status messages.....	339
----------------------	-----

Supported paper.....	62
----------------------	----

System.....	297
-------------	-----

System information.....	271
-------------------------	-----

System settings.....	234, 276
----------------------	----------

T

TCP/IP status.....	293
Time setting.....	311
Toner.....	271
Toner saving.....	283
Top page.....	269
Trademarks.....	429
Transfer Rollor.....	324
Transmission mode.....	182
Trap.....	297
Tray 1.....	48
Tray 1 priority.....	278
Tray 2.....	277
Tray paper settings.....	276
Troubleshooting.....	376, 378, 379
Error and status messages on the screen.....	339
Other problems.....	359, 360, 363, 366, 389
TWAIN scanning.....	159

U

User code.....	291
User restriction.....	15

W

Waste toner bottle.....	318, 417
Web Image Monitor.....	268
What you can do with this machine	
Copier function.....	99
Fax function.....	171
Printer function.....	81
Scanner function.....	123
Wireless LAN settings.....	300
Wireless settings.....	300

MEMO

MEMO

