



---

Canopy rangehood

---

User manual

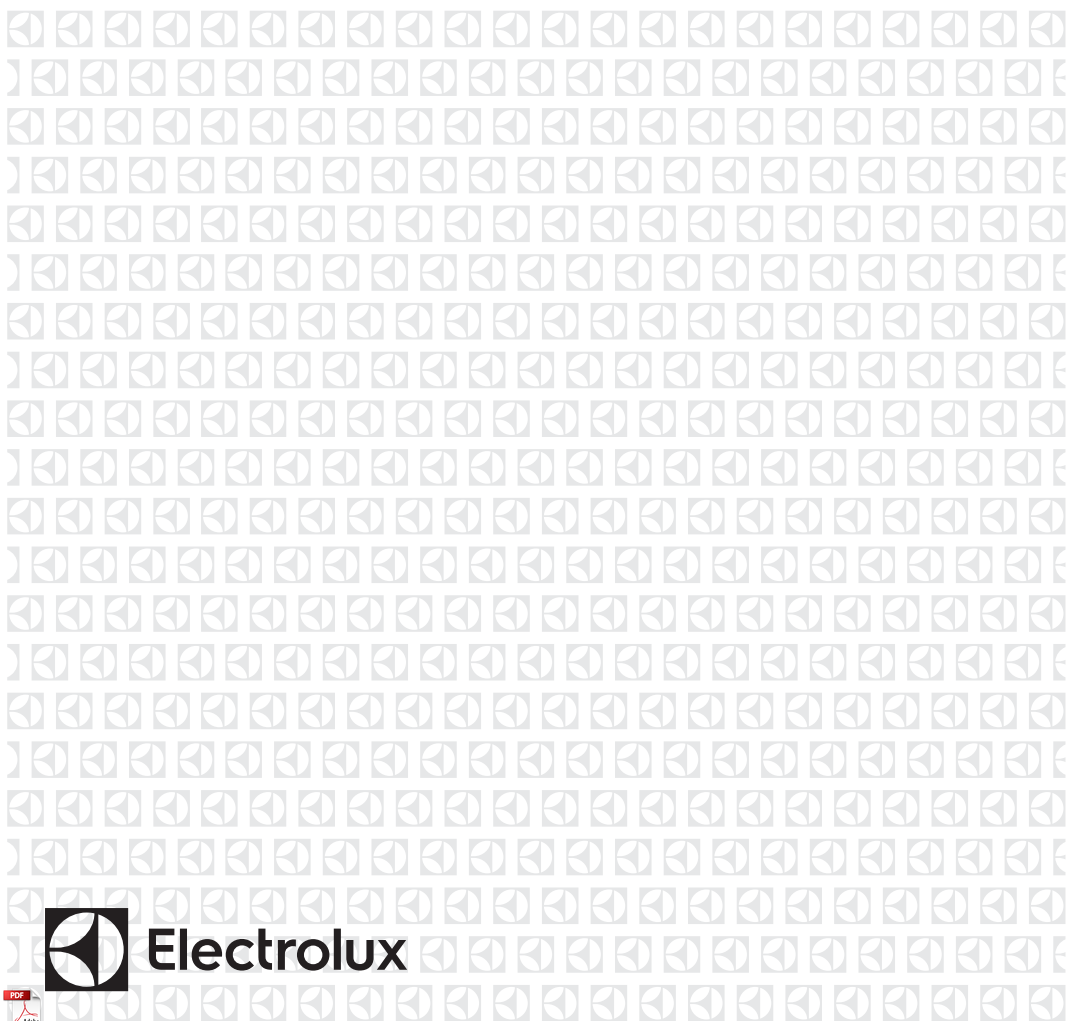

## CONGRATULATIONS

Dear customer,

Thank you for purchasing an Electrolux rangehood. You've chosen a product that brings with it decades of professional experience and innovation. Ingenious and stylish, it has been designed with you in mind. So whenever you use it, you can be safe in the knowledge that you'll get great results every time.

Welcome to Electrolux.

The symbols you will see in this booklet have these meanings:



### WARNING

**This symbol indicates information concerning your personal safety.**



### CAUTION

**This symbol indicates information on how to avoid damaging the rangehood.**



### IMPORTANT

**This symbol indicates tips and information about use of the rangehood.**



### ENVIRONMENT

**This symbol indicates tips and information about economical and ecological use of the rangehood.**

## CONDITIONS OF USE

This appliance is intended to be used in household and similar applications such as:

- Staff kitchen areas in shops, offices and other working environments
- Farm houses
- By clients in hotels, motels and other residential type environments
- Bed and breakfast type environments
- Catering and similar non-retail applications

Record model and serial number here:

Model number: \_\_\_\_\_

Serial number: \_\_\_\_\_

## CONTENTS

Important instructions _____	3
Before using your appliance _____	3
Information on disposal for users _____	3
Important safety instructions _____	3
Care & Cleaning _____	5
Description _____	6
General hints _____	7
Care & Cleaning _____	8
Long life charcoal filter _____	8
Grease filters _____	8
Replacing the lamps _____	8
Troubleshooting _____	9
Technical data _____	10
Installation _____	11
Recirculated _____	21
Ducted _____	33
Warranty _____	43

# IMPORTANT INSTRUCTIONS

## Important Information that may impact your Manufacturer's Warranty

Adherence to the directions for use in this manual is extremely important for health and safety. Failure to strictly adhere to the requirements in this manual may result in personal injury, property damage and affect your ability to make a claim under the Electrolux manufacturer's warranty provided with your product. Products must be used, installed and operated in accordance with this manual. You may not be able to claim on the Electrolux manufacturer's warranty in the event that your product fault is due to failure to adhere to this manual.

## BEFORE USING YOUR APPLIANCE

Before you use the appliance, we recommend that you read through the relevant sections of this manual, which provides the description of your appliance and its functions.

To avoid the risks that are always present when you use an appliance, it is important that the appliance is installed correctly and that you read the safety instructions carefully to avoid misuse and hazards.

We recommend that you keep this instruction booklet for future reference and pass it on to any future owners.

This appliance complies with the requirements of Australian Standards AS/NZS 60335.2.31



### IMPORTANT

**Check for any damage or marks. If you find the appliance is damaged or marked, you must report it within 7 days if you wish to claim for damage/marks under the manufacturer's warranty. This does not affect your statutory rights.**

## INFORMATION ON DISPOSAL FOR USERS



### ENVIRONMENT

**Most of the packing materials are recyclable. Please dispose of those materials through your local recycling depot or by placing them in appropriate collection containers.**

**If you wish to discard this appliance, please contact your local authorities and ask for the correct method of disposal.**

## IMPORTANT SAFETY INSTRUCTIONS



### WARNING

**These warnings have been provided in the interest of safety. You MUST read them carefully before installing or using the appliance.**



### WARNING

**The wire connection has to be done by specialized technician.**

- The manufacturer will not be held liable for any damages resulting from incorrect or improper installation.
- The minimum safety distance between the cooker top and the extractor hood is: for electrical hob 600mm and for gas hob 650mm.
- If the instructions for installation for the gas hob specify a greater distance, this must be respected.
- Check that the mains voltage corresponds to that indicated on the rating plate fixed to the inside of the hood.
- Means for disconnection must be incorporated in the fixed wiring in accordance with the wiring rules.



### CAUTION

**In order to avoid a hazard due to inadvertent resetting of the thermal cut-out, this appliance must not be supplied through an external switching device, such as a timer, or connected to a circuit that is regularly switched on and off by the utility.**

- For Class I appliances, check that the domestic power supply guarantees adequate earthing.
- Connect the extractor to the exhaust flue through a pipe of minimum diameter 120 mm. The route of the flue must be as short as possible.
- If the extractor is used in conjunction with non-electrical appliances (e.g. gas burning appliances), a sufficient degree of aeration must be guaranteed in the room in order to prevent the backflow of exhaust gas. When the cooker hood is used in conjunction with appliances supplied with energy other than electric, the negative pressure in the room must not exceed 0,04 mbar to prevent fumes being drawn back into the room by the cooker hood.
- The air must not be discharged into a flue that is used for exhausting fumes from appliances burning gas or other fuels.
- If the supply cord is damaged, it must be replaced from the manufacturer or its service agent.

# IMPORTANT INSTRUCTIONS (CONTINUED)

- Connect the plug to a socket complying with current regulations, located in an accessible place.
- With regards to the technical and safety measures to be adopted for fume discharging it is important to closely follow the regulations provided by the local authorities.
- Adjust the flame intensity to direct it onto the bottom of the pan only, making sure that it does not engulf the sides.
- Deep fat fryers must be continuously monitored during use: overheated oil can burst into flames.



## WARNING

**Before installing the Hood, remove the protective films.**

- Use only screws and small parts in support of the hood.



## WARNING

**Failure to install the screws or fixing device in accordance with these instructions may result in electrical hazards.**

- Connect the hood to the power net by using a bipolar switch having a contact gap of at least 3 mm.
- Do not look directly at the light through optical devices (binoculars, magnifying glasses...).
- Do not flambè under the range hood; risk of fire.
- This appliance is not intended for use by persons (including children) with reduced physical, sensory or mental capabilities, or lack of experience and knowledge, unless they have been given supervision or instruction concerning use of the appliance by a person responsible for their safety.
- Children should be supervised to ensure that they do not play with the appliance.



## WARNING

**Accessible parts may become hot when used with cooking appliances.**

- Clean and/or replace the Filters after the specified time period (Fire hazard).
- There shall be adequate ventilation of the room when the range hood is used at the same time as appliances burning gas or other fuels (not applicable to appliances that only discharge the air back into the room)
- Switch off or unplug the appliance from the mains supply before carrying out any maintenance work.
- The top of the hood must not be used as a shelf.
- The extractor hood has been designed exclusively for domestic use to eliminate kitchen smells.
- Never use the hood for purposes other than for which it has been designed.
- Never leave high naked flames under the hood when it is in operation.



## CAUTION

**Accessible parts may become hot when used with cooking appliances.**

## CARE AND CLEANING

- Grease filters must be cleaned every 2 months of operation, or more frequently for particularly heavy usage, and can be washed in a dishwasher.
- Clean the hood using a damp cloth and a neutral liquid detergent.
- There is a fire risk if cleaning is not carried out in accordance with the instructions.

# DESCRIPTION

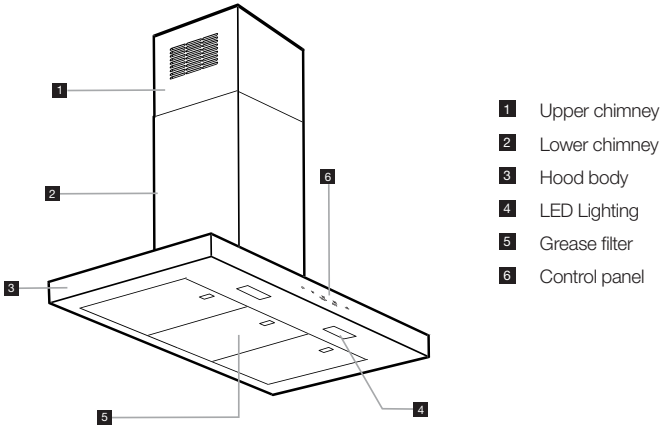

## CONTROL PANEL

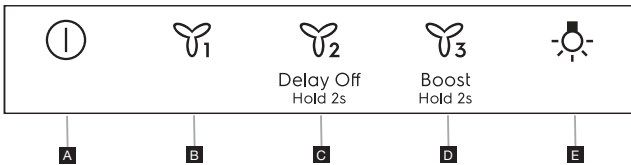

button	function
A = Off	Turns off the motor.  Press and hold the button for approximately 2 seconds, with all the loads turned off (Motor+Lights), to reset the Filter saturation alarm. All led flashes three times.  With the motor turned off: Saturation of the grease filters takes place after 100 hours of continuous operation of the hood. Led A: Flashes once a second.
B = Speed	Turns the motor on at speed 1.  Press and hold the button for approximately 2 seconds, with all the loads turned off (Motor+Lights), to turn the Activated Charcoal Filter alarm on. LED (A) flashes twice to confirm  To turn the alarm off, press the button again and hold for at least 2 seconds. The relevant LED flashes once (A).
C = Speed	Turns the Motor on at speed 2.  Press and hold the button for 2 seconds to activate delay off function for speed 1, 2 and 3. After 6 minutes the fan will automatically turn off.
D = Speed	Turns the motor on at speed 3.  Press and hold for 2 seconds to activate intensive Boost speed. After 6 minutes, the motor will automatically return to the speed that the hood was previously set to.
E = Light	Press briefly: Turns the lighting system on and off at maximum intensity  Press and hold to change the lighting intensity up or down.

# GENERAL HINTS

Switch ON the hood at minimum speed when you start cooking and kept it running for few minutes after cooking is finished.

- Increase the speed only in case of large amount of smoke and vapour and use boost speed(s) only in extreme situations.
- Replace the charcoal filter(s) when necessary to maintain a good odour reduction efficiency.
- Clean the grease filter(s) when necessary to maintain a good grease filter efficiency.
- Use the maximum diameter of the ducting system indicated in this manual to optimize efficiency and minimize noise.

## **Hob to Hood remote control**

*NOTE: This Hood can be switched on remotely by certain cooktops that have compatible Hob to Hood capability.*

The Hob to Hood remote capability is always active for this hood, just install it above a compatible cooktop with Hob to Hood capability to use this feature directly.

# CARE AND CLEANING

**⚠ WARNING**

**Switch off or unplug the appliance from the mains supply before carrying out any maintenance work.**

**i IMPORTANT**

**Clean the hood using a damp cloth and a neutral liquid detergent.**

### Long Life Carbon Filter

The anti-odour filter can be washed and regenerated every 3-4 months (or more frequently if the hood is subject to intensive use), up to a Max. of 8 regeneration cycles (in case of particularly intensive use it is recommended that you do not exceed 5 cycles).

#### Regeneration procedure:

Wash in the dishwasher at a Max temperature of 70°C or hand wash in hot water without using abrasive sponges (do not use detergents!).

Dry in the oven at a Max temperature of 70°C for 2 hours or dry at room temperature, standing the filter in a vertical position to facilitate drainage.

*NOTE: Replacement carbon filters are available from Electrolux spare parts.*

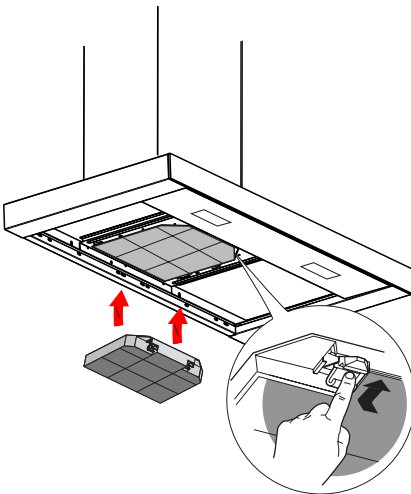

### Grease Filters

Clean or replace the filters continuously according to below time intervals, to maintain good performance of the hood and to prevent a potential fire hazard, caused by excessive grease build-up. The grease filters must be cleaned every 2 months of operation, or more frequently for particularly heavy usage, and can be washed in a dishwasher.

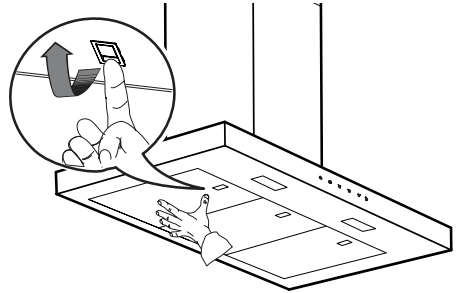

### Replacing the lamps

For replacement, please contact an Authorised Service Center.



# TROUBLE SHOOTING

If there is a fault, first try to find a solution to the problem yourself. If you cannot find a solution to the problem yourself, contact an authorized service center.

problem	possible cause	solution
Appliance not stable	The appliance is not correctly installed	Follow the Installation instruction enclosed to the appliance.
Appliance is not in horizontal position	The appliance is not correctly installed	Follow the Installation instruction enclosed to the appliance.
Performance in terms of oil capture are not satisfying	Oil and grease on metal filters or charcoal filters.	Follow the cleaning frequency of filters as described in the user manual
Appliance does not work	The appliance is not correctly connected	Verify that the main cable is connected to the motor group or the plug is connected to the socket
The light does not work	The LED is broken	For replacement, contact the Authorised Service Centre.
Noise of hood is higher than customer expectation.	Air outlet diameter in the wall is too small, causing a pressure drop and an increase in motor speed.	Follow the Installation instruction enclosed to the appliance.
	Product is installed in recirculation mode.	Product in recirculation mode (and using a charcoal filter) will generate an higher noise than a product in extration mode.
	More than one bend in the ventilation duct.	If the exhaust system in the building has multiple bend in or a long distance, this can increase the noise of the product.

## Before contacting the Authorised Service Centre:

Switch the appliance on again to see if the problem has disappeared. If not, switch it off again and repeat the operation after an hour.

If your appliance still does not work properly after carrying out the checks listed in the troubleshooting guide and switching the appliance on again, contact the Authorised Service Centre, clearly explaining the problem and specifying:

- the type of fault;
- the model;
- the type and serial number of the appliance (given on the rating plate).

# TECHNICAL DATA

		<b>unit</b>	<b>value</b>
Product Type			Wall mounted hood
Dimensions	Width	mm	898
	Depth	mm	460
	Height min/max	mm	<b>800/1210</b>
Airflow max (Exhaust mode)		m <sup>3</sup> /h	790
Noise min/max (sound power level)		dBA	50/70
Total Power		W	274
Lamps info	Type		Rectangular LED
	Number & Power		2x 2W
	Socket		N/A
Installation minimum height - gas hob		mm	650
Installation minimum height - elec hob		mm	600
Net Weight		Kg	15

# INSTALLATION

The hood has been designed to be installed and used either as a "**Exhausted mode**", or as a "**Recirculation mode**".



## Exhausted mode

Cooking steam is sucked and channelled outside the house through a discharge duct (not supplied), fitted to the hood steam outlet.

Ensure that the discharge duct is correctly fitted to the air outlet, unit using an appropriate connection system.

*NOTE: It is not recommended to have a carbon filter fitted when operating in exhausted mode*



## Recirculation mode

The air is filtered through one or more the charcoal filters, and then resent into room.



### IMPORTANT

**Ensure appropriate air circulation around the hood.**



### IMPORTANT

If the hood is supplied without charcoal filters and installed on recirculation mode, these must be fitted before the hood can be used. Filters are available in shops. The hood should be installed away from particularly dirty areas, windows, doors and heat sources. The accessories for wall fixing are not included because wall made of different materials require different types of fixing accessories. Use fixing systems suitable for the walls of your home and the weight of the appliance. For more details, contact a specialised dealer. Keep this booklet for future consultation.



### WARNING

**Fixing devices for the wall are not included since different wall materials require different types of fixing devices. Use fixing devices suitable for the walls in your home and for the weight of the appliance. For advice on suitable fixing systems, contact your local specialised dealer.**



### WARNING

**Failure to install the screws or fixing device in accordance with these instructions may result in electrical hazards.**

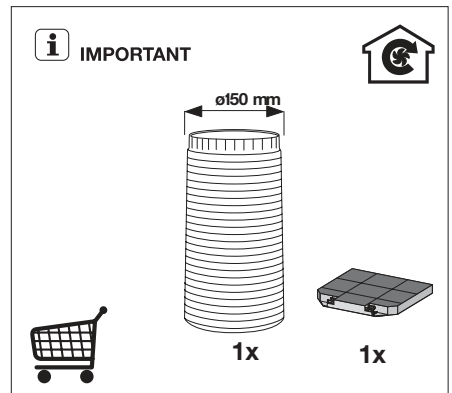
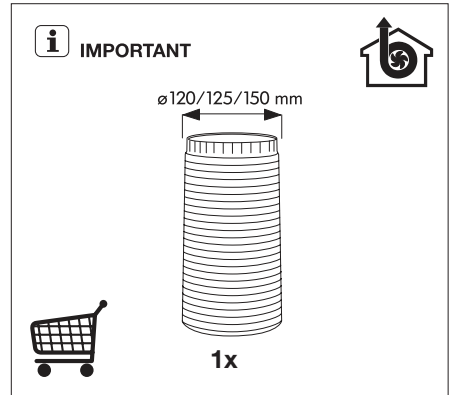
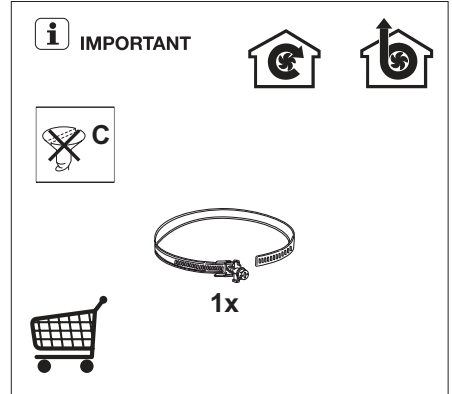

# INSTALLATION (CONTINUED)

**i** IMPORTANT

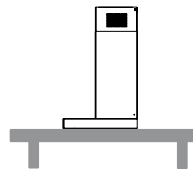
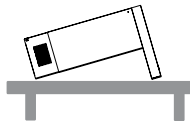
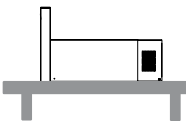
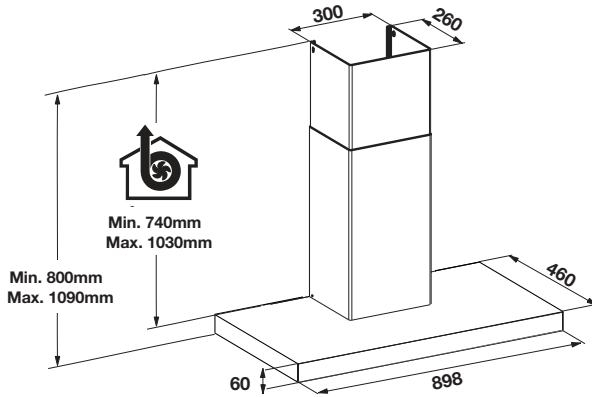
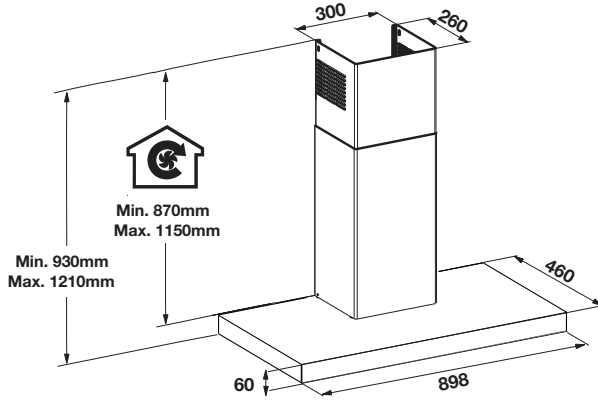

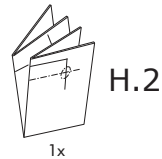
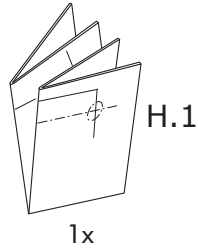
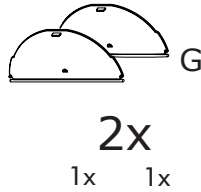
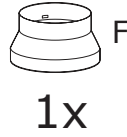
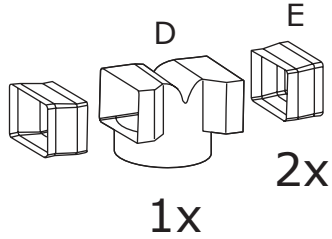
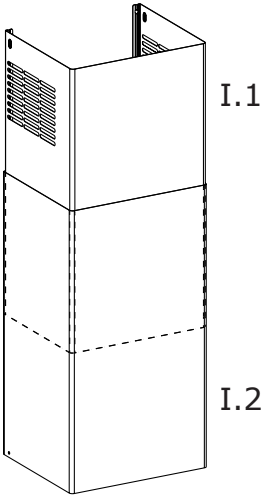
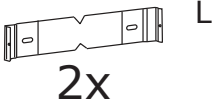
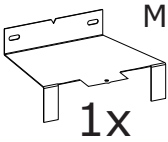
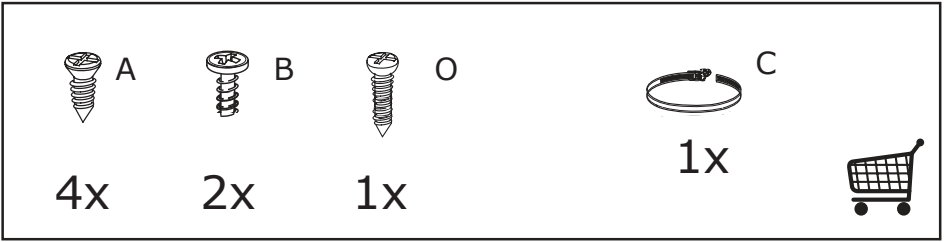

# INSTALLATION (CONTINUED)

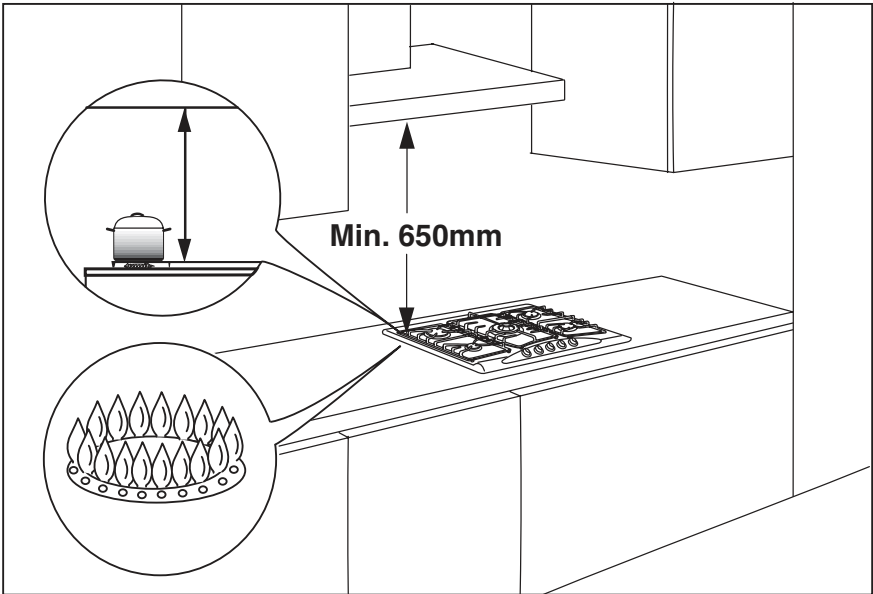
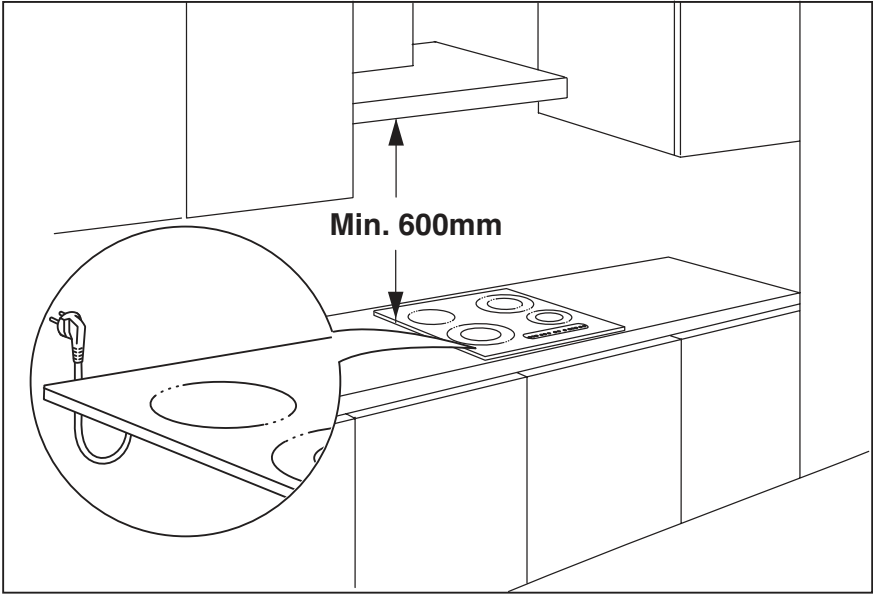

1

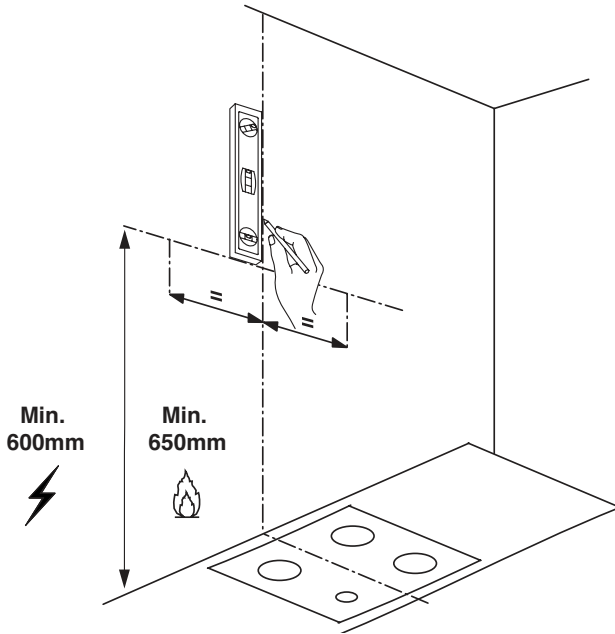

2

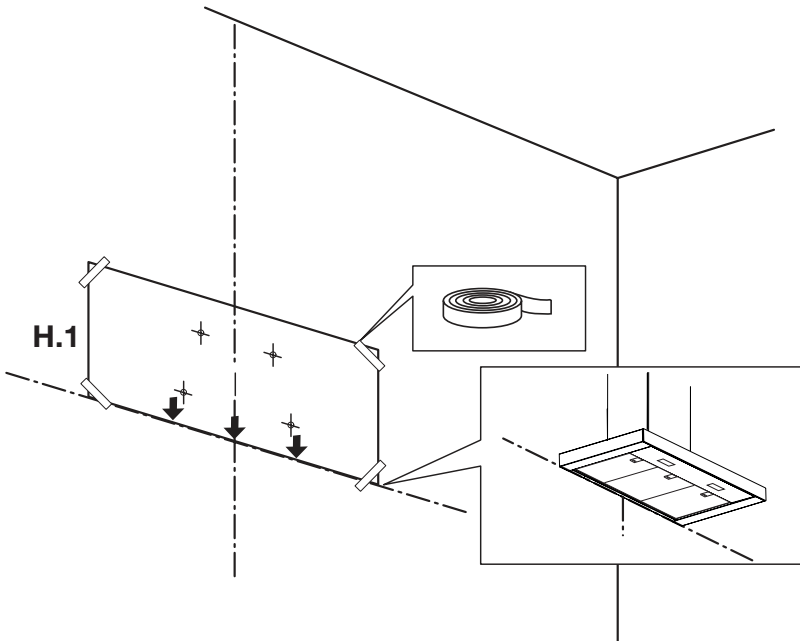

# INSTALLATION (CONTINUED)

**3**

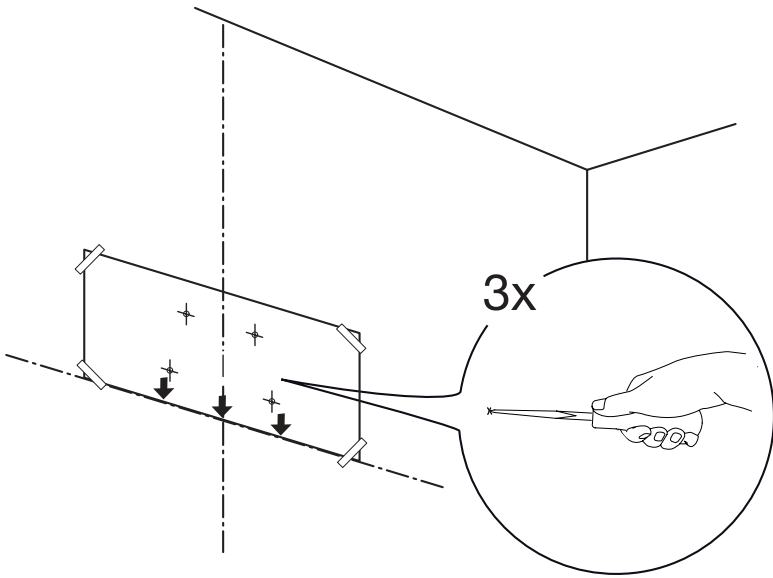

**4**

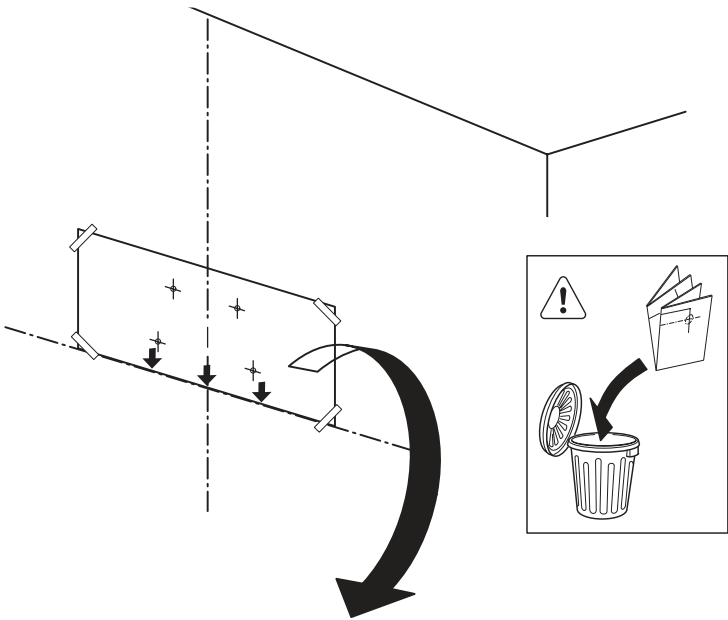



5

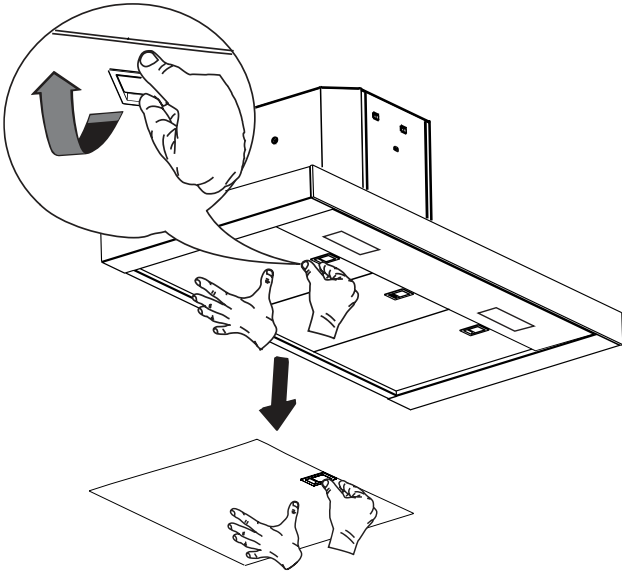

**i** IMPORTANT

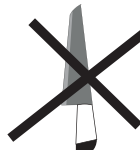
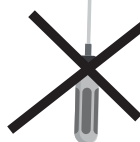
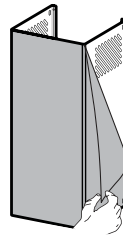
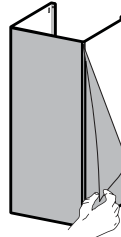
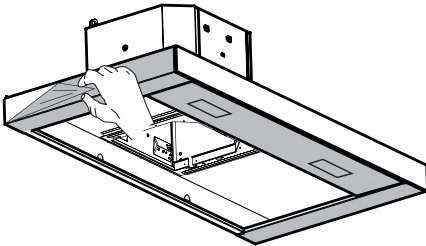
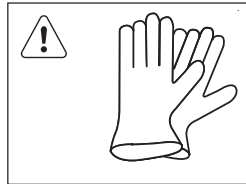
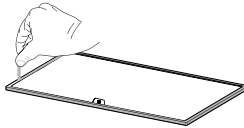

# INSTALLATION (CONTINUED)

**i** IMPORTANT

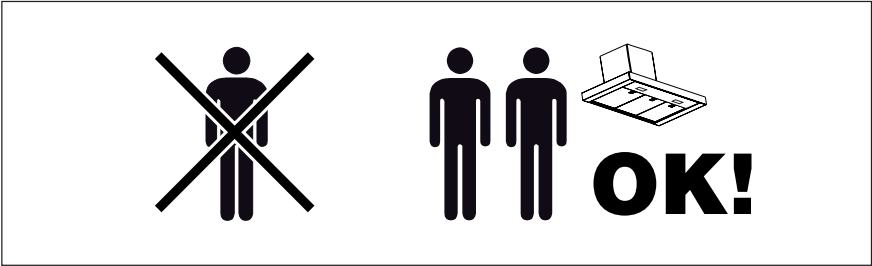

**6**

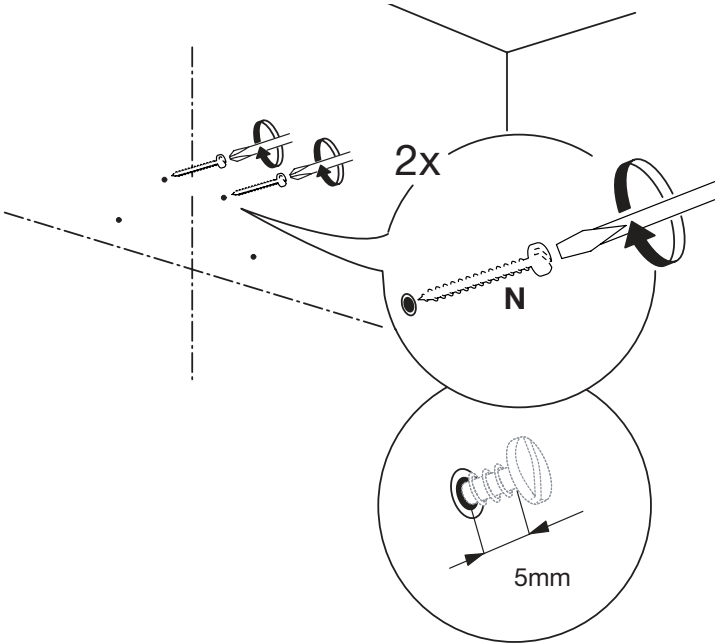

7

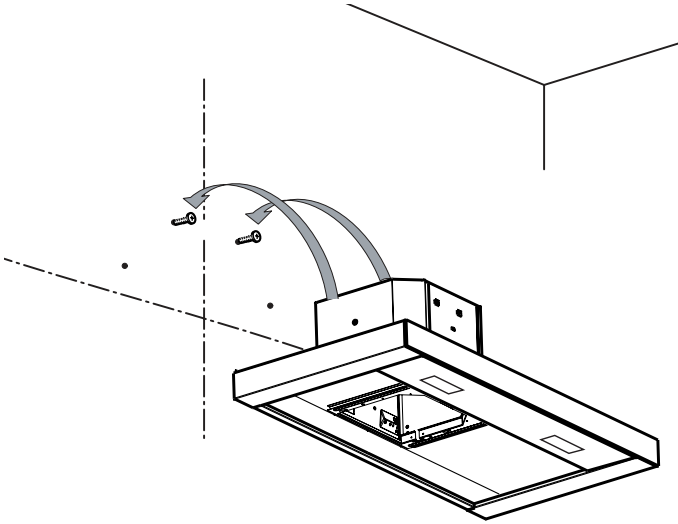

8

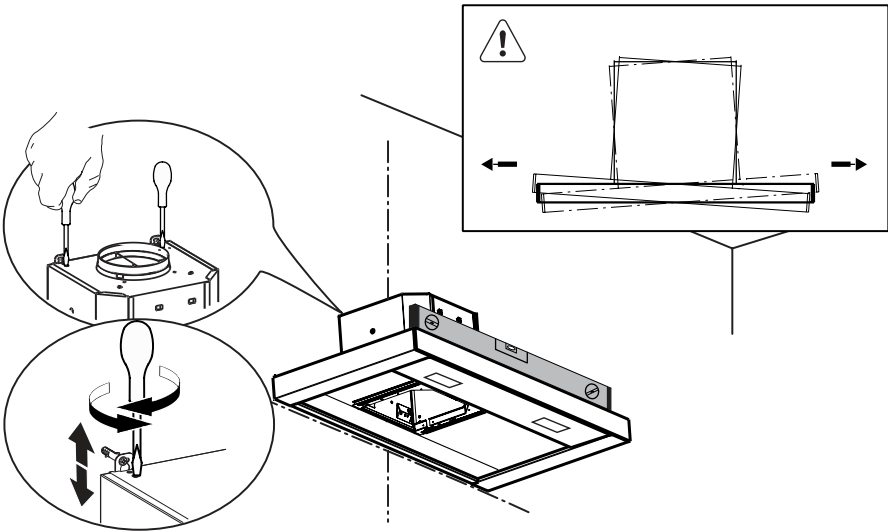

# INSTALLATION (CONTINUED)

## 9

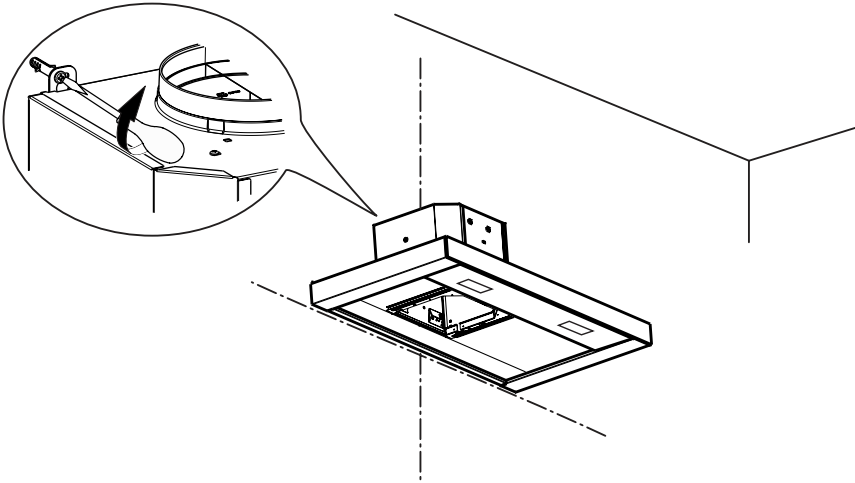

## 10

**i** IMPORTANT

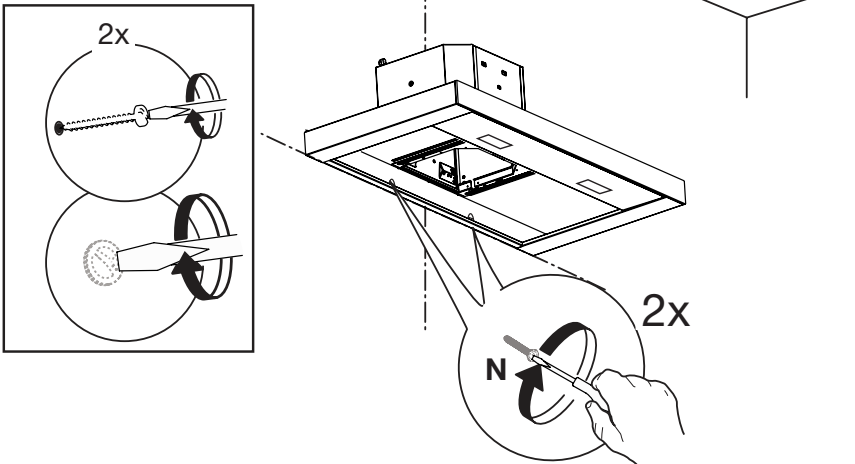

### RECIRCULATED INSTALLATION

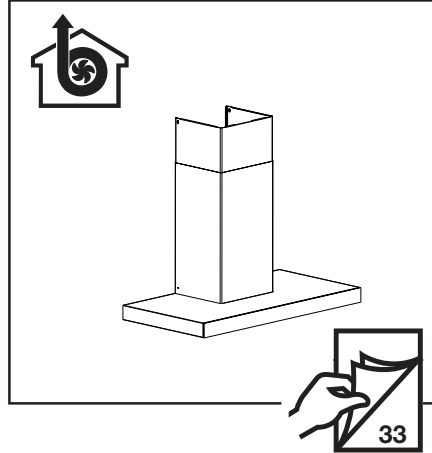
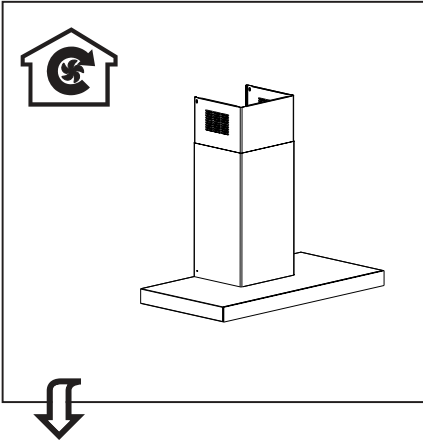

For Ducted installation go to page 33

**i** IMPORTANT

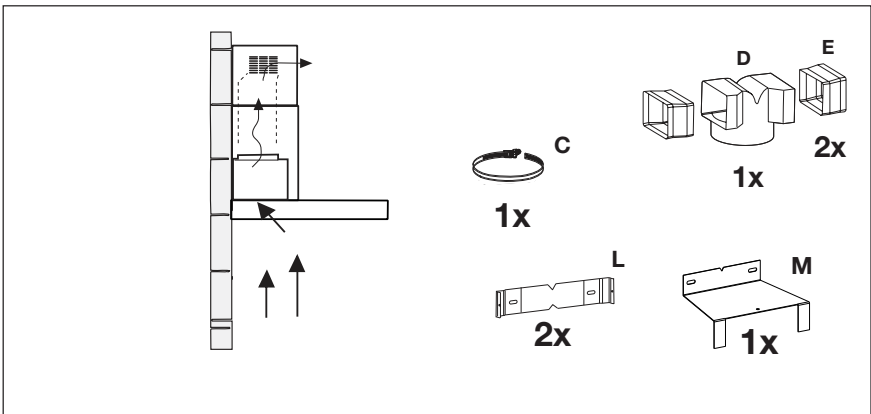

# INSTALLATION (CONTINUED)

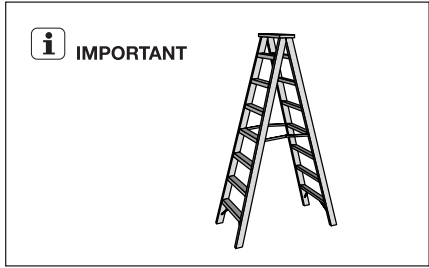
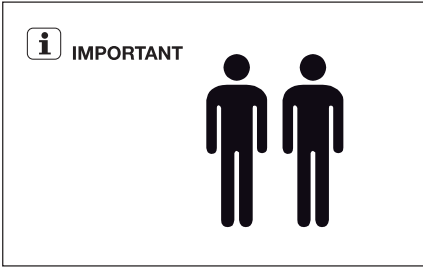

# 11

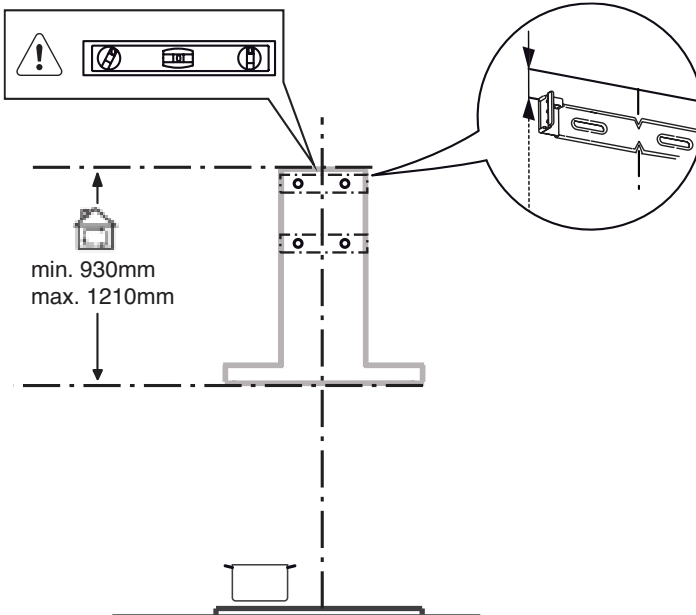

12

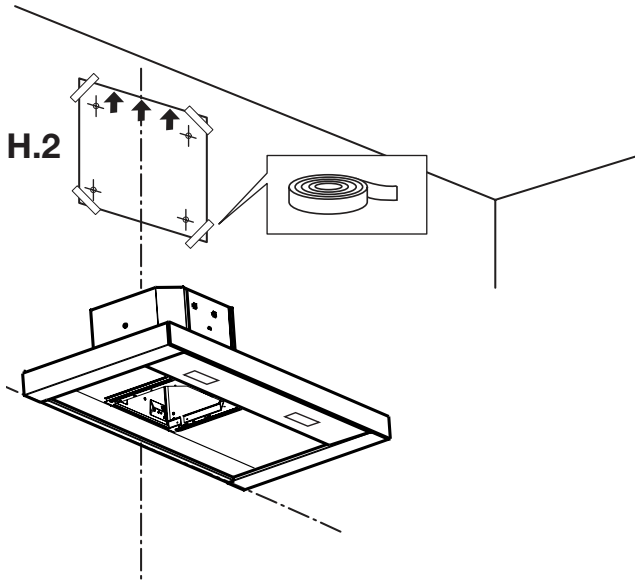

13

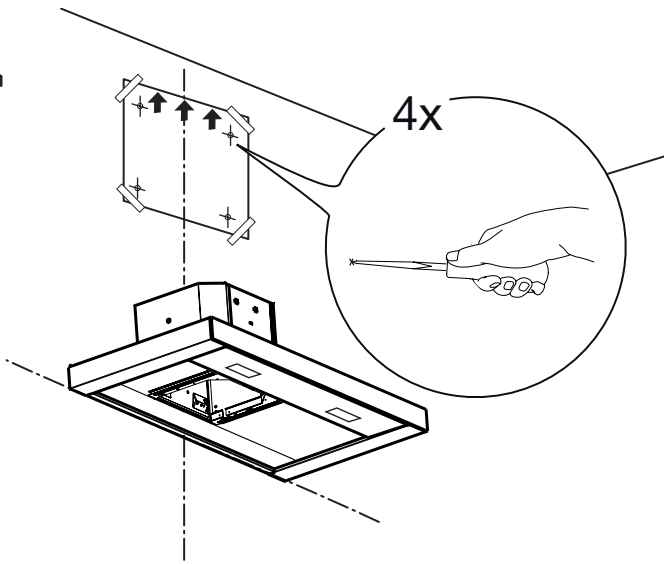

# INSTALLATION (CONTINUED)

## 14

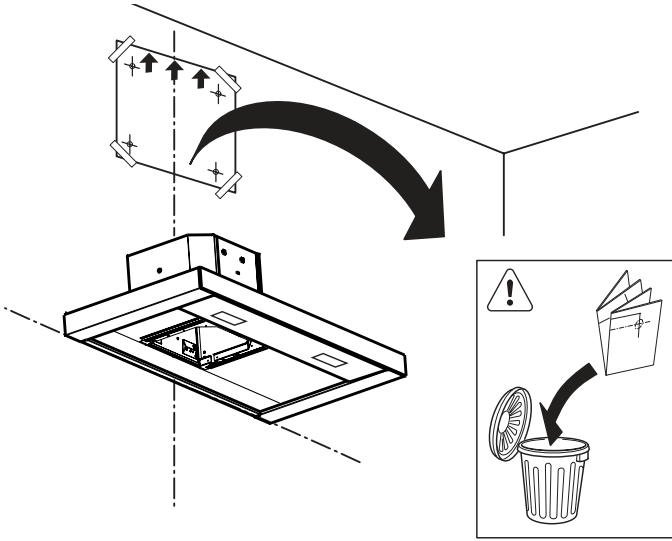

## 15

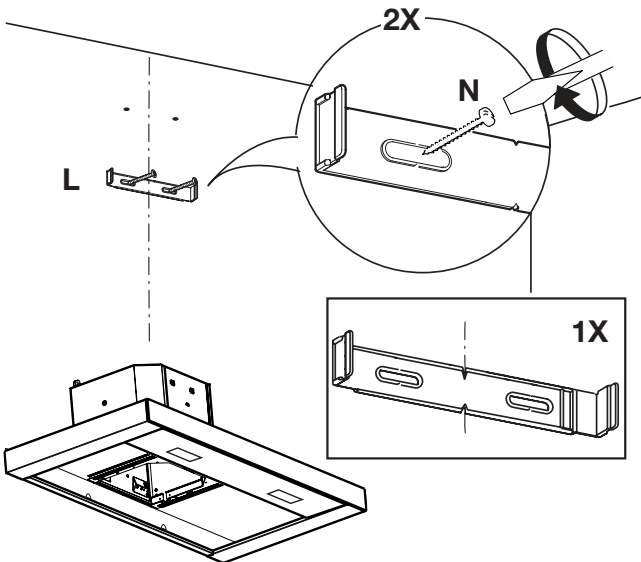



16

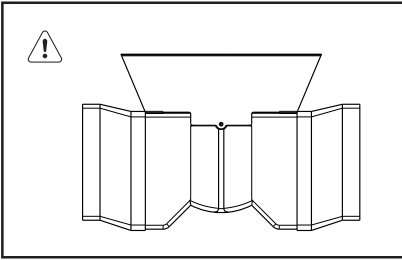
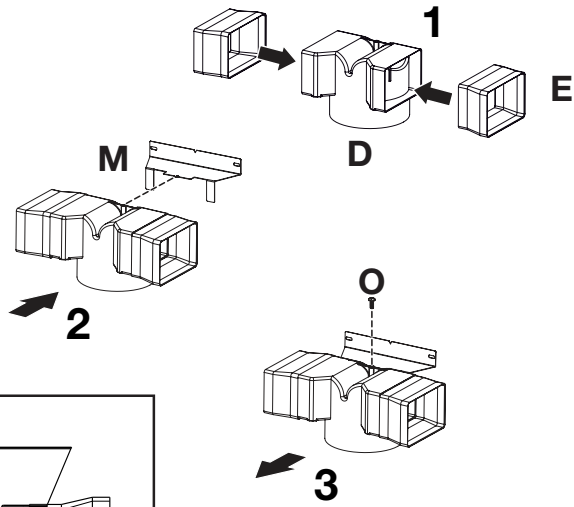

17

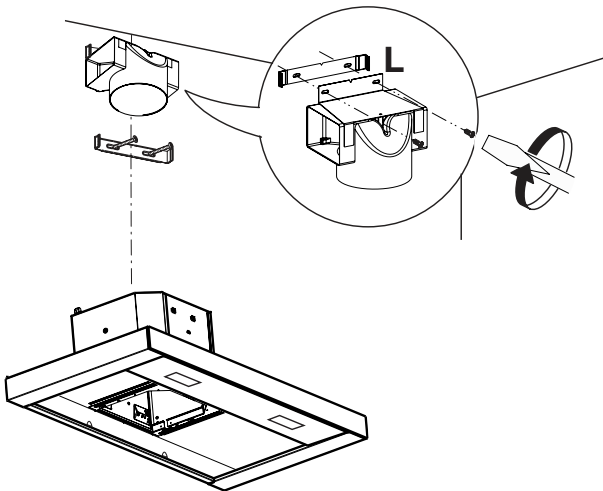

# INSTALLATION (CONTINUED)

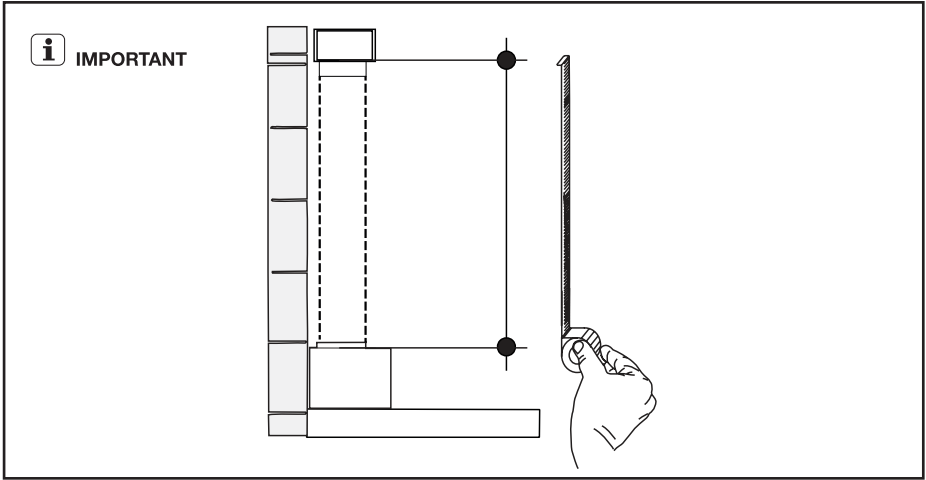

## 18

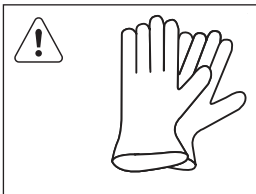
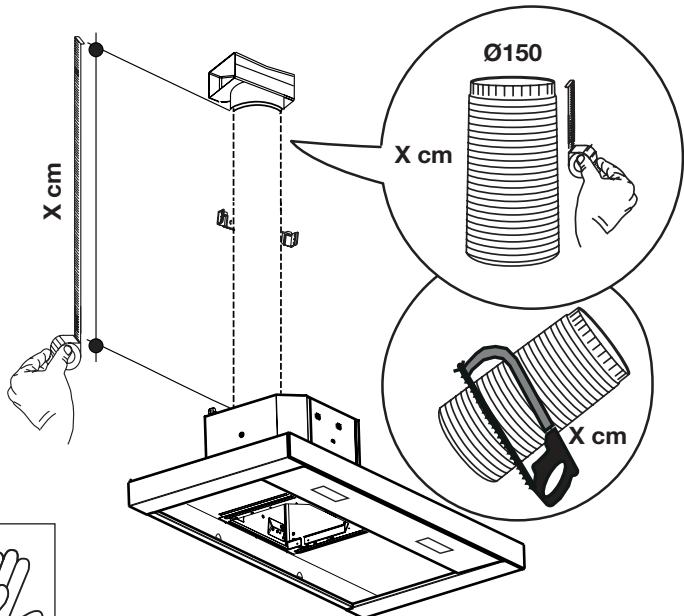

19

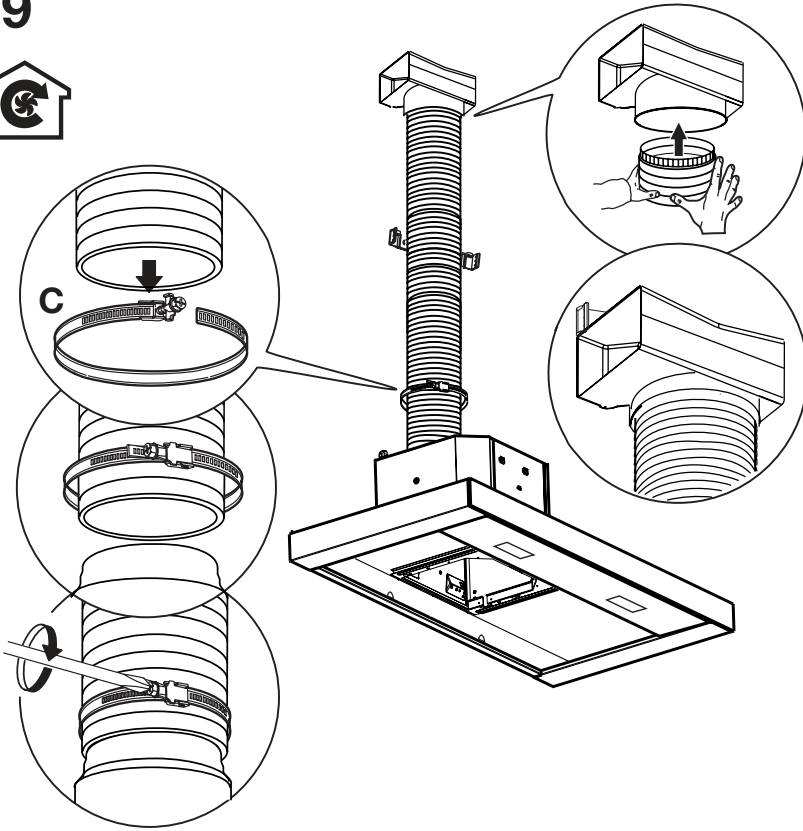

# INSTALLATION (CONTINUED)

## 20

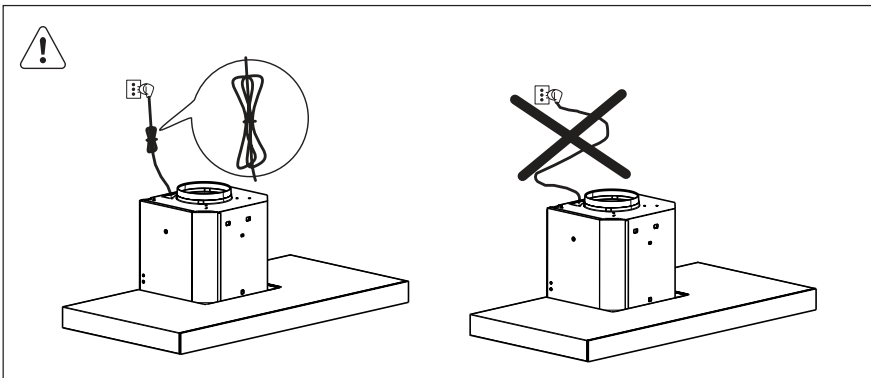
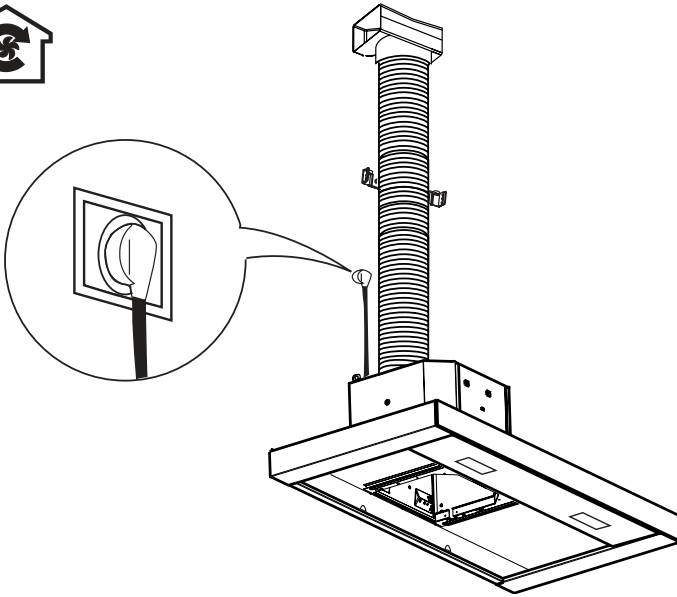

21

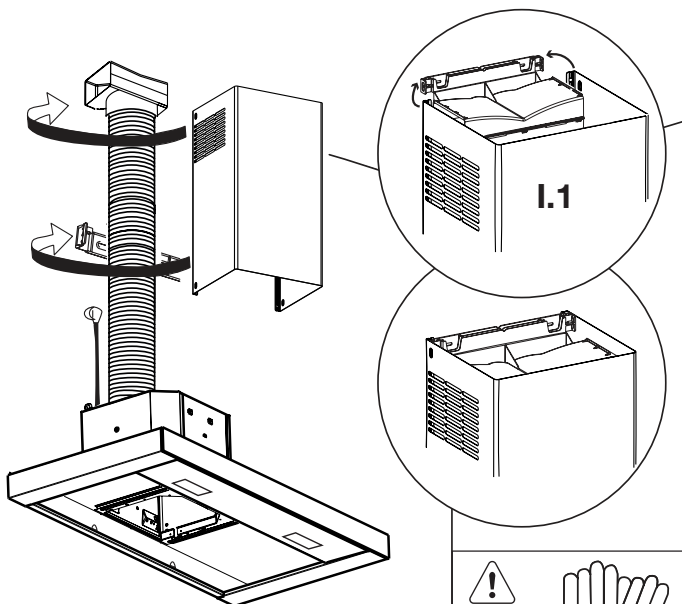

22

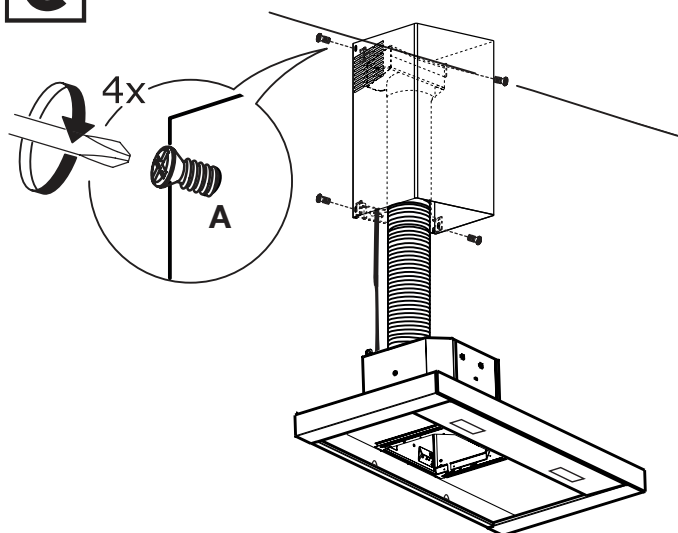

# INSTALLATION (CONTINUED)

## 23

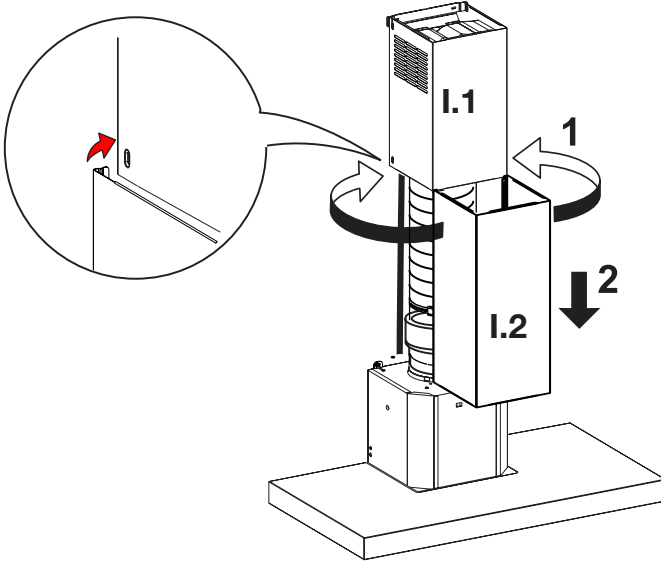

## 24

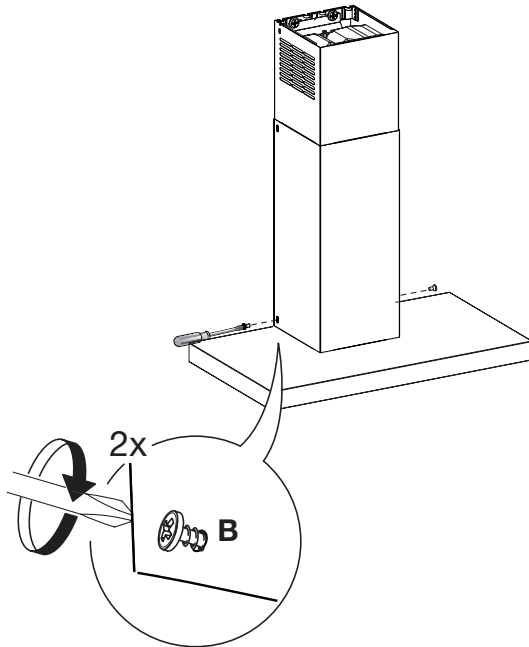

25

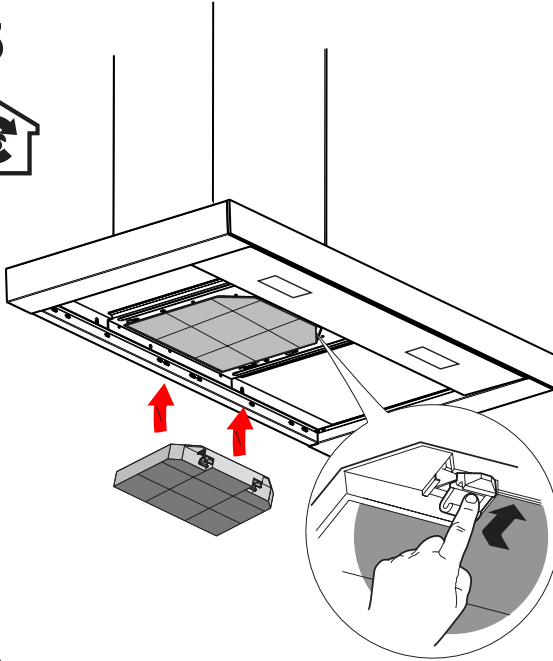

26

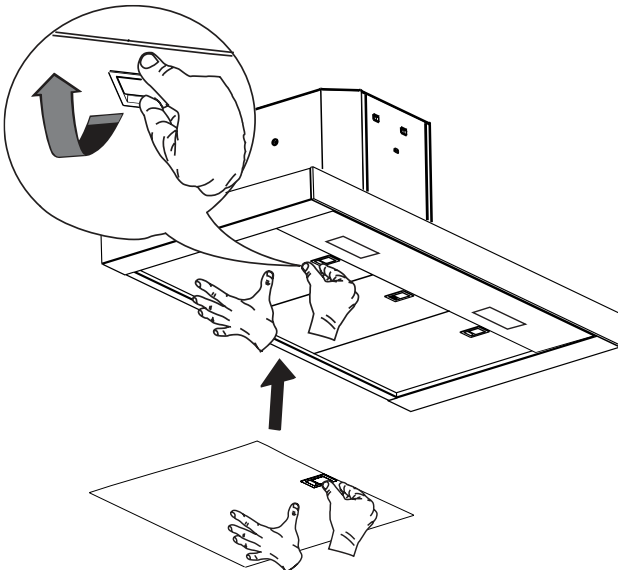

# INSTALLATION (CONTINUED)

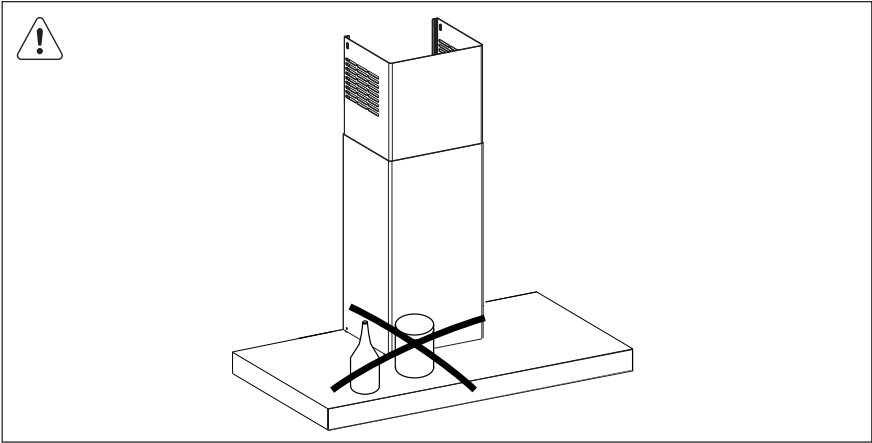



### DUCTED INSTALLATION

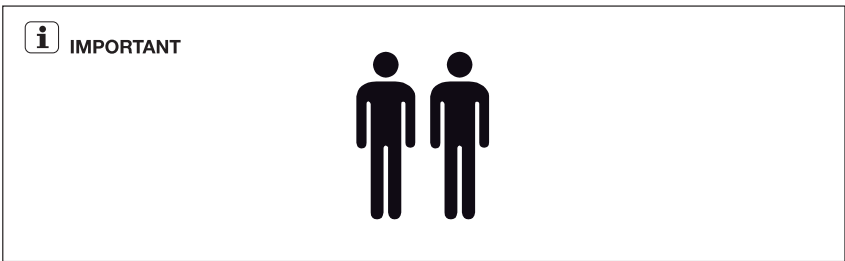
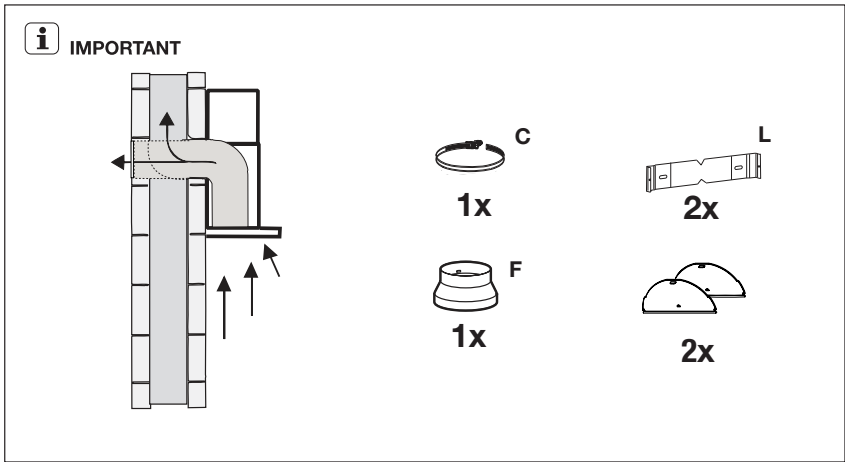
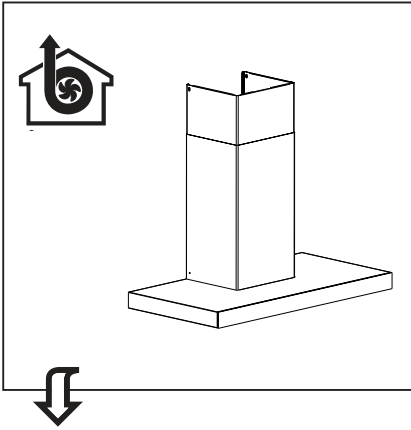

# INSTALLATION (CONTINUED)

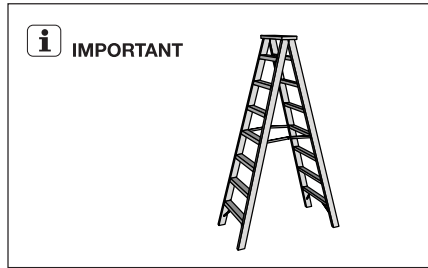
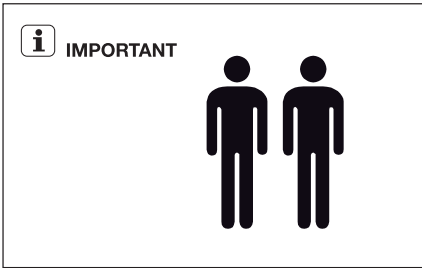

# 11

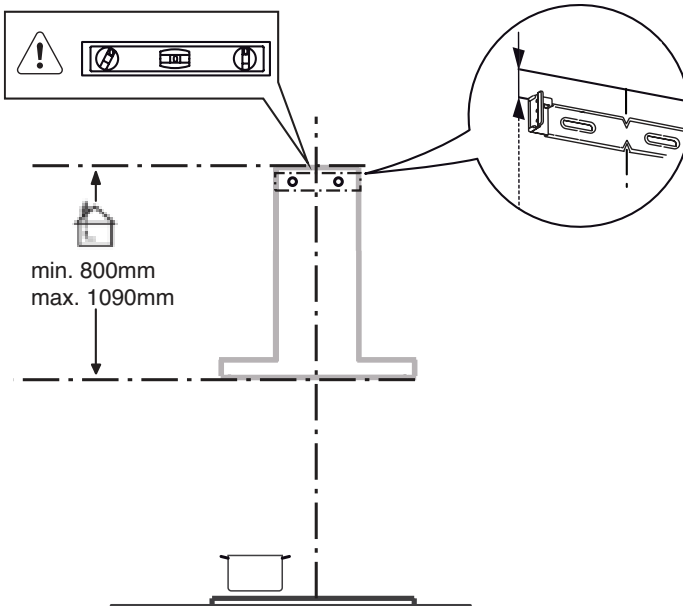

12



H.2

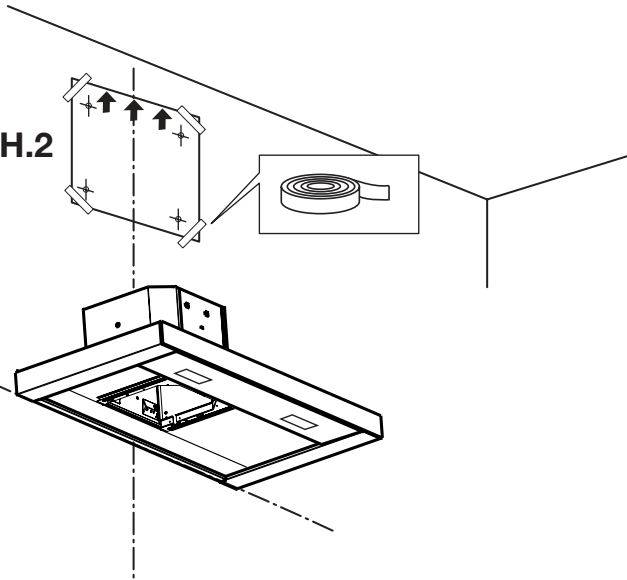

13



4x

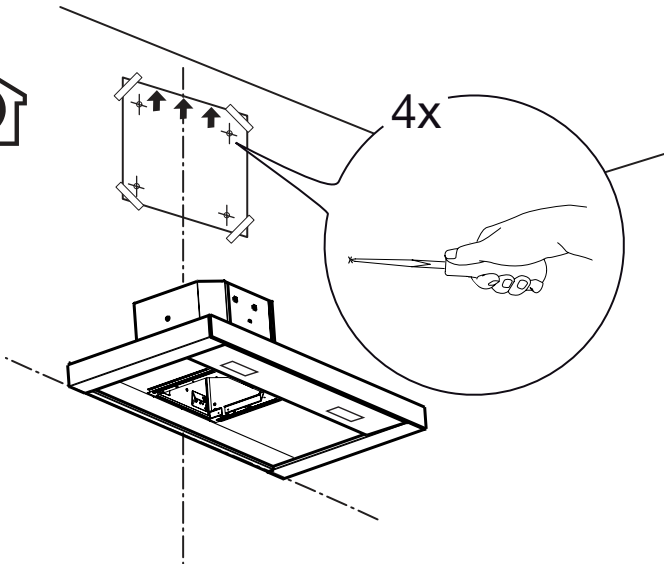

# INSTALLATION (CONTINUED)

## 14

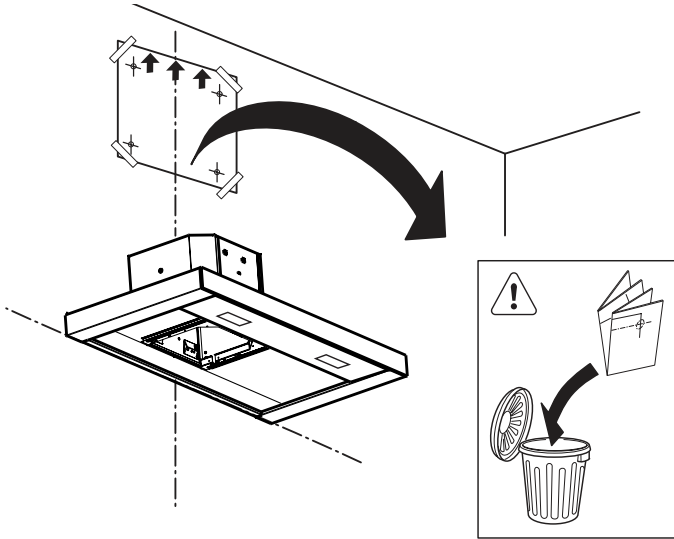

## 15

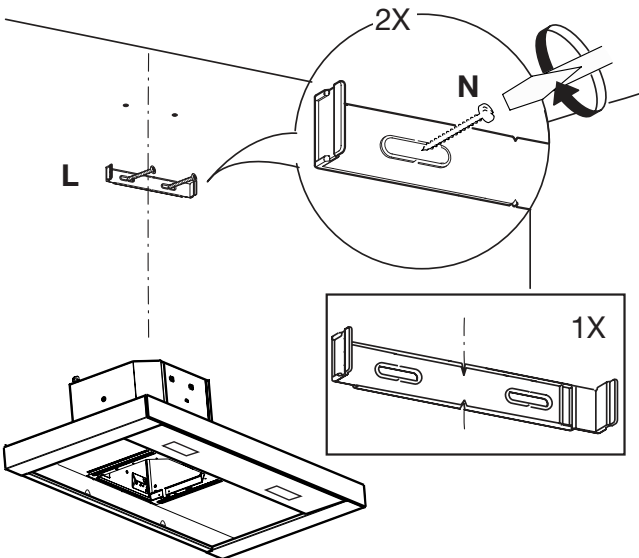

16

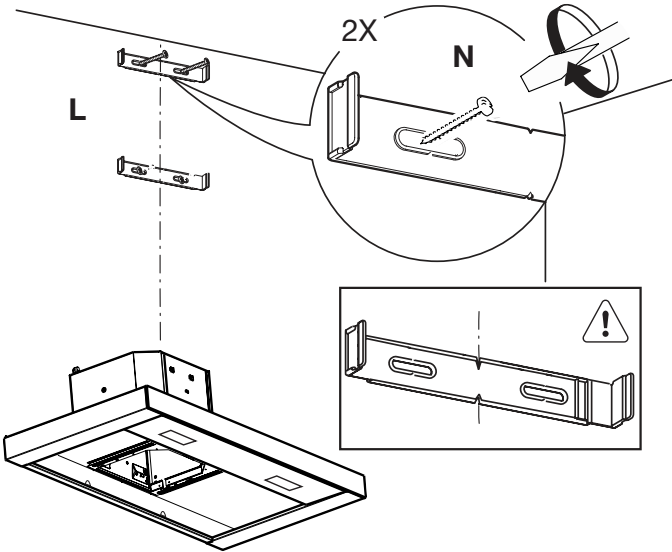

17

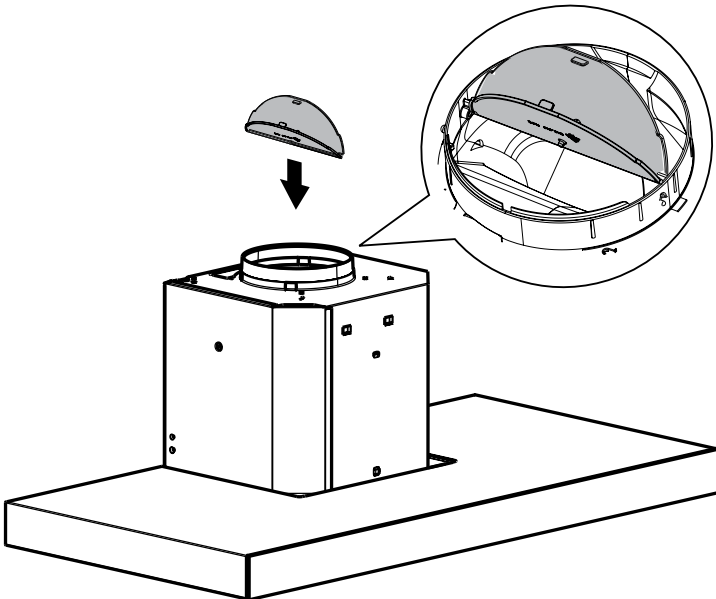

# INSTALLATION (CONTINUED)

## 18

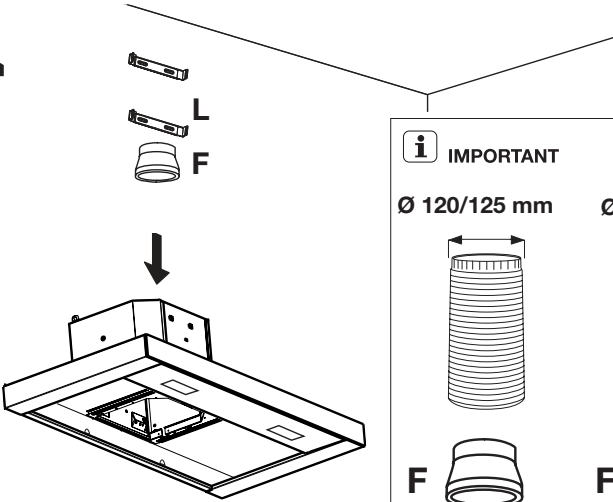

**i** IMPORTANT

Ø 120/125 mm	Ø 150 mm

**i** IMPORTANT

19

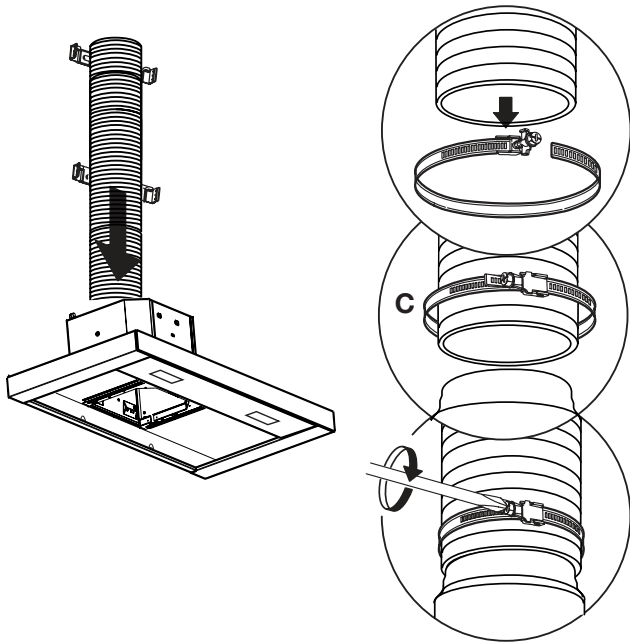

20

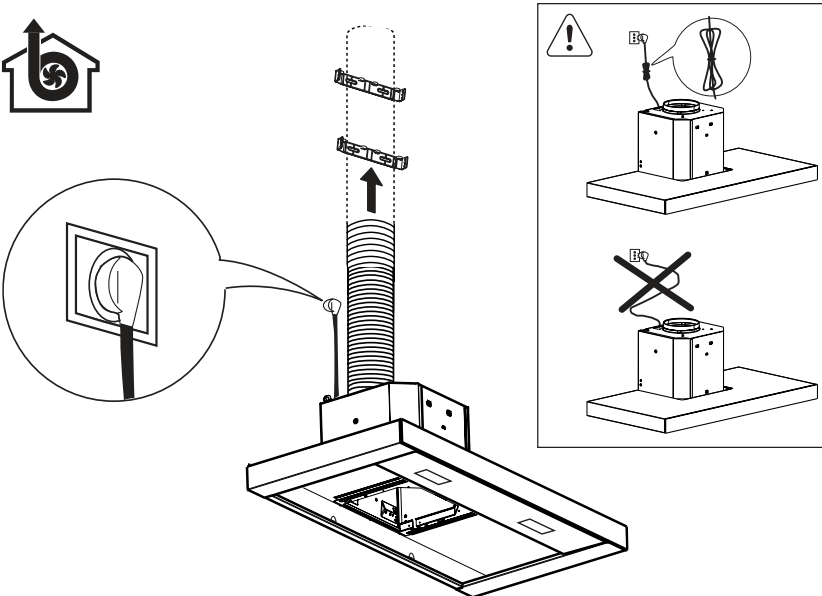

# INSTALLATION (CONTINUED)

## 21

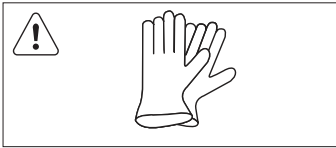
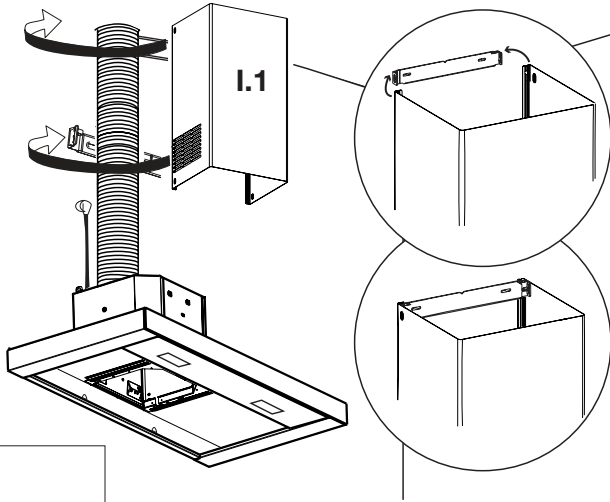

## 22

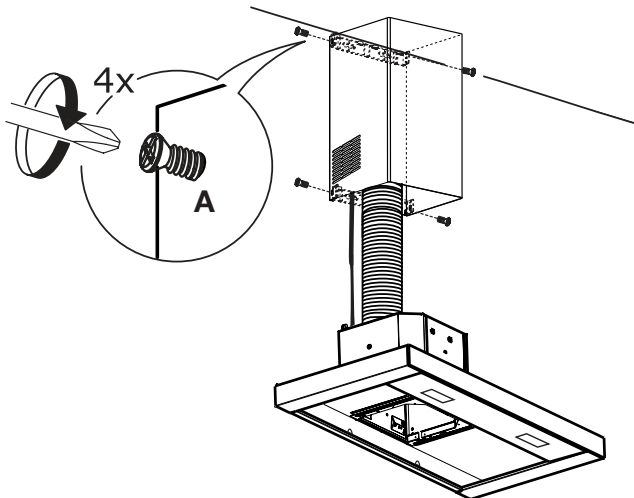



23

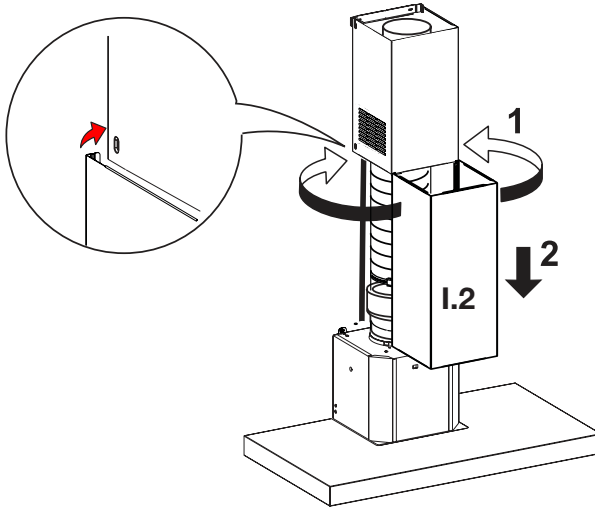

24

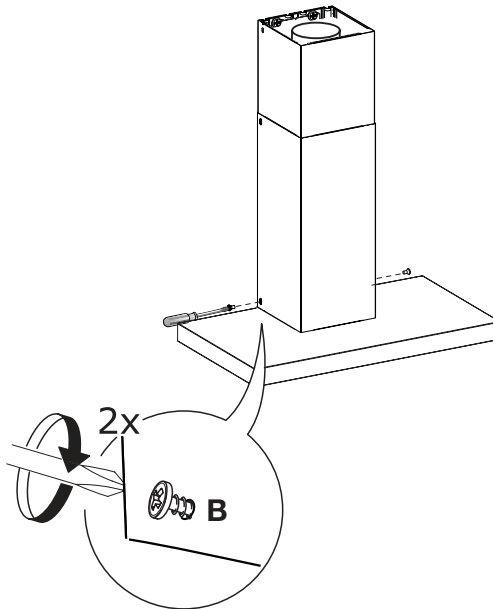

25

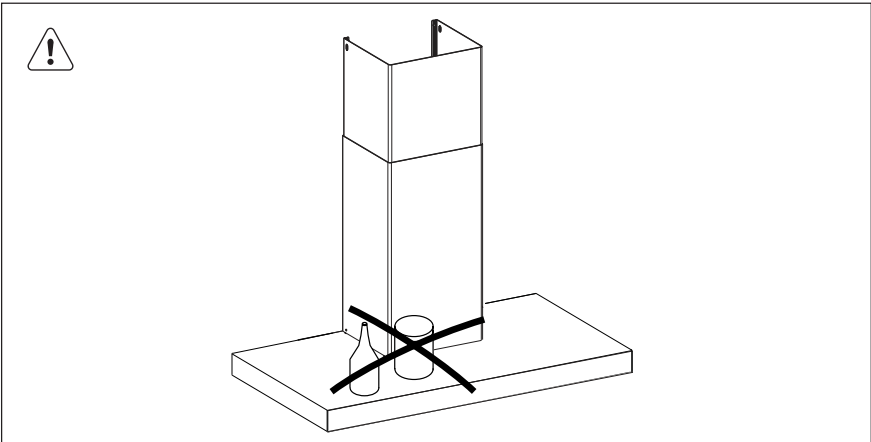
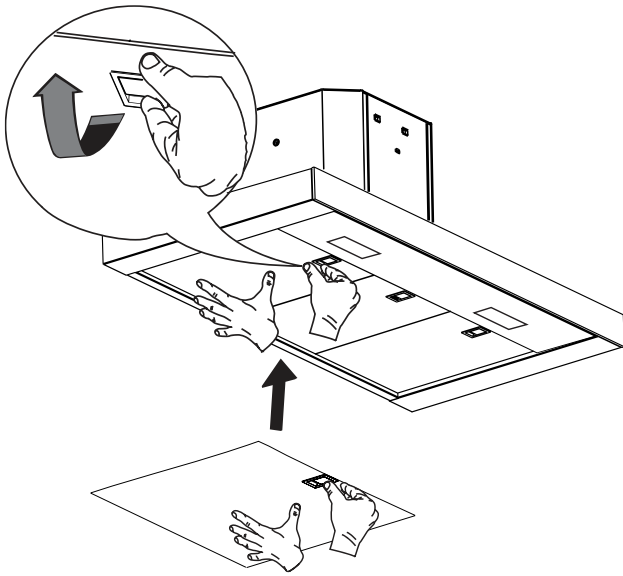

**This document sets out the terms and conditions of the product warranties for Electrolux Appliances. It is an important document. Please keep it with your proof of purchase documents in a safe place for future reference should there be a manufacturing defect in your Appliance. This warranty is in addition to other rights you may have under the Australian Consumer Law.**

**1. In this warranty:**

- (a) 'ACL' or 'Australian Consumer Law' means Schedule 2 to the Competition and Consumer Act 2010;
- (b) 'Appliance' means any Electrolux product purchased by you and accompanied by this document;
- (c) 'ASC' means Electrolux's authorised serviced centres;
- (d) 'Electrolux' is the brand controlled by Electrolux Home Products Pty Ltd of 163 O'Riordan Street, Mascot NSW 2020, ABN 51 004 762 341 in respect of Appliances purchased in Australia and Electrolux (NZ) Limited (collectively "Electrolux") of 3-5 Niall Burgess Road, Mount Wellington, in respect of Appliances purchased in New Zealand;
- (e) 'Warranty Period' means the period specified in clause 3 of this warranty;
- (f) 'you' means the purchaser of the Appliance not having purchased the Appliance for re-sale, and 'your' has a corresponding meaning.

**2. Application:** This warranty only applies to new Appliances, purchased and used in Australia or New Zealand and is in addition to (and does not exclude, restrict, or modify in any way) other rights and remedies under a law to which the Appliances or services relate, including any non-excludable statutory guarantees in Australia and New Zealand.

**3. Warranty Period:** Subject to these terms and conditions, this warranty continues for in Australia for a period of 24 months and in New Zealand for a period of 24 months, following the date of original purchase of the Appliance.

**4. Repair or replace warranty:** During the Warranty Period, Electrolux or its ASC will, at no extra charge if your Appliance is readily accessible for service, without special equipment and subject to these terms and conditions, repair or replace any parts which it considers to be defective. Electrolux may, in its absolute discretion, choose whether the remedy offered for a valid warranty claim is repair or replacement. Electrolux or its ASC may use refurbished parts to repair your Appliance. You agree that any replaced Appliances or parts become the property of Electrolux.

**5. Travel and transportation costs:** Subject to clause 7, Electrolux will bear the reasonable cost of transportation, travel and delivery of the Appliance to and from Electrolux or its ASC. Travel and transportation will be arranged by Electrolux as part of any valid warranty claim.

**6. Proof of purchase** is required before you can make a claim under this warranty.

**7. Exclusions:** You may not make a claim under this warranty unless the defect claimed is due to faulty or defective parts or workmanship. This warranty does not cover:

- (a) light globes, batteries, filters or similar perishable parts;
- (b) parts and Appliances not supplied by Electrolux;
- (c) cosmetic damage which does not affect the operation of the Appliance;

- (d) damage to the Appliance caused by:
  - (i) negligence or accident;
  - (ii) misuse or abuse, including failure to properly maintain or service;
  - (iii) improper, negligent or faulty servicing or repair works done by anyone other than an Electrolux authorised repairer or ASC;
  - (iv) normal wear and tear;
  - (v) power surges, electrical storm damage or incorrect power supply;
  - (vi) incomplete or improper installation;
  - (vii) incorrect, improper or inappropriate operation;
  - (viii) insect or vermin infestation;
  - (ix) failure to comply with any additional instructions supplied with the Appliance;

In addition, Electrolux is not liable under this warranty if:

- (a) the Appliance has been, or Electrolux reasonably believes that the Appliance has been, used for purposes other than those for which the Appliance was intended, including where the Appliance has been used for any non-domestic purpose;
- (b) the Appliance is modified without authority from Electrolux in writing;
- (c) the Appliance's serial number or warranty seal has been removed or defaced

**8. How to claim under this warranty:** To enquire about claiming under this warranty, please follow these steps:

- (a) carefully check the operating instructions, user manual and the terms of this warranty;
- (b) have the model and serial number of the Appliance available;
- (c) have the proof of purchase (e.g. an invoice) available;
- (d) telephone the numbers shown below.

**9. Australia:** For Appliances and services provided by Electrolux in Australia: Electrolux goods come with guarantees that cannot be excluded under the Australian Consumer Law. You are entitled to a replacement or refund for a major failure and for compensation for any other reasonably foreseeable loss or damage. You are also entitled to have the Appliance repaired or replaced if the Appliance fails to be of acceptable quality and the failure does not amount to a major failure. 'Acceptable quality' and 'major failure' have the same meaning as referred to in the ACL.

**10. New Zealand:** For Appliances and services provided by Electrolux in New Zealand, the Appliances come with a guarantee by Electrolux pursuant to the provisions of the Consumer Guarantees Act, the Sale of Goods Act and the Fair Trading Act. Where the Appliance was purchased in New Zealand for commercial purposes the Consumer Guarantee Act does not apply.

**11. Confidentiality:** You accept that if you make a warranty claim, Electrolux and its agents including ASC may exchange information in relation to you to enable Electrolux to meet its obligations under this warranty.

**Important Notice**

Before calling for service, please ensure that the steps listed in clause 8 above have been followed.

<p><b>FOR SERVICE</b> or to find the address of your nearest authorised service centre in Australia <b>PLEASE CALL 13 13 49</b> <small>For the cost of a local call (Australia only)</small></p>	<p><b>AUSTRALIA</b> ELECTROLUX HOME PRODUCTS 163 O'Riordan Street, Mascot NSW 2020 electrolux.com.au</p>	<p><b>FOR SPARE PARTS</b> or to find the address of your nearest spare parts centre in Australia <b>PLEASE 13 13 50</b> <small>For the cost of a local call (Australia only)</small></p>
<p><b>FOR SERVICE</b> or to find the address of your nearest authorised service centre in New Zealand <b>PLEASE CALL 0800 10 66 10</b> <small>(New Zealand only)</small></p>	<p><b>NEW ZEALAND</b> ELECTROLUX (NZ) Limited 3-5 Niall Burgess Road, Mount Wellington electrolux.co.nz</p>	<p><b>FOR SPARE PARTS</b> or to find the address of your nearest spare parts centre in New Zealand <b>PLEASE 0800 10 66 20</b> <small>(New Zealand only)</small></p>

**Electrolux Home Products Australia**

telephone: 1300 363 640  
fax: 1800 350 067  
email: [customercare@electrolux.com.au](mailto:customercare@electrolux.com.au)  
web: [electrolux.com.au](http://electrolux.com.au)

**shop.electrolux.com.au**



**Electrolux Home Products New Zealand**

telephone: 0800 436 245  
fax: 0800 225 088  
email: [customercare@electrolux.co.nz](mailto:customercare@electrolux.co.nz)  
web: [electrolux.co.nz](http://electrolux.co.nz)



991.0567.372\_03 - 210519  
D0005434\_02

To add a touch of  
professional inspiration  
to your home,  
visit [electrolux.com.au](http://electrolux.com.au)  
or [electrolux.co.nz](http://electrolux.co.nz)

[electrolux.com.au](http://electrolux.com.au)



or [electrolux.co.nz](http://electrolux.co.nz)

