

Color and Finish Codes

**SO-SVCN-\_\_-\_\_**  
**GRAFIK Systems**  
**Sivoia QED™ Controller**

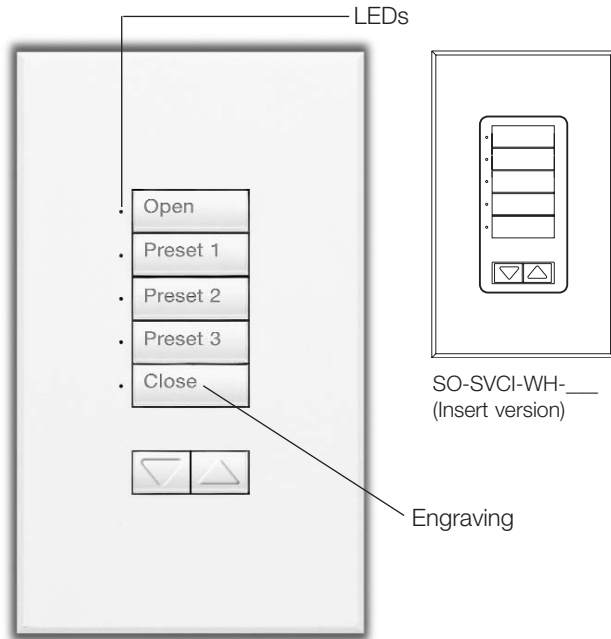

SO-SVCN-WH-E01

SO-SVCI-WH-\_\_  
 (Insert version)

**Description**

- Provides programming and control of one group of Sivoia QED™ Window Treatments.
- Allows selection of preset window treatment levels from GRAFIK Systems.
- Connects to both the GRAFIK™ Systems link and the Sivoia QED Electronic Drive Unit (EDU) link.
- One SO-SVC needed per group of Sivoia QED Window Treatments (up to 96 devices).
- Maximum of 32 GRAFIK Systems Sivoia QED Controllers per wallstation link.
- Large, rounded buttons are easy to use.
- Backlit buttons with optional engraving make it easy to find and operate the control in low light conditions.
- Optional button engraving is angled up to the eye for easy reading.
- Pressing the Open button once will cause the window treatments move to their fully open position. If the Open button is pressed again while the window treatments are opening, the movement of the window treatments will stop.
- Pressing the Preset 1, Preset 2, or Preset 3 button once will cause the window treatments to move to the first, second, and third preset level, respectively. If the Preset 1, Preset 2, or Preset 3 button is pressed while the window treatments are moving to that position, the window treatments will stop.
- Pressing the Close button once will cause the window treatments move to their fully closed position. If the Close button is pressed again while the window treatments are closing, the movement of the window treatments will stop.
- Pressing the Raise/Lower buttons will cause the window treatments to open/close while the button is pressed.
- The LEDs next to each button are used during programming and provide feedback of the current Sivoia QED preset.
- Works with GRAFIK 5000™, 6000®, and 7000® Systems.

**Finish and Engraving Options**

- Available with button engraving.
- Standard and Non-Standard text engraving available. For more details, visit the website at [www.lutron.com/seetouch](http://www.lutron.com/seetouch).

Job Name:	Model Numbers:
Job Number:	

## Specifications

### Power

Low-voltage type PELV (Class 2: USA). Operating voltage: 24 V $\sim$ , supplied by Sivoia QED System.

### Key Design Features

- Field-changeable button and faceplate assemblies allow easy customization.
- Front accessible DIP switches allow change of function without removing the unit from the wall.
- Meets IEC 801-2. Tested to withstand 15 kV electro-static discharge without damage or memory loss.
- Faceplate snaps on with no visible means of attachment.
- Available as an “insert” style control for multi-gangging.
- Can be ganged to share a common faceplate with NovaT\*<sup>®</sup> and Vareo<sup>®</sup> Dimmers. To order new Wallplates for multi-gangging, specify “R3” openings in a Lutron NovaT\* multi-gang FB (fins broken) Series model number.
- Use Button Replacement Kits to change color, button configuration, or engraving.
- Button Replacement Kits may also be used to convert between non-insert and insert configurations.

### System Communications and Capacity

- Low-voltage type PELV (Class 2: USA) wiring connects Wallstations and Sivoia QED Controllers to GRAFIK Systems components.
- The Sivoia QED Controller is wired on the GRAFIK 5000<sup>™</sup>, 6000<sup>®</sup>, or 7000<sup>®</sup> wallstation/CSD link.
- Up to 32 GRAFIK Systems Sivoia QED Controllers may be connected per wallstation/CSD link.
- Each GRAFIK Systems Sivoia QED Controller is capable of controlling up to 96 Electronic Drive Units as a group.
- Each Sivoia QED Electronic Drive Unit requires its own 24 V $\sim$  transformer.

### Terminals

Communications to GRAFIK Systems Central Processor: One 4-pin removable terminal block. Each pin will accept one wire up to #18 AWG (1.0 mm<sup>2</sup>).

Communications to Sivoia QED EDU: One 5-pin removable terminal block. Each pin will accept one wire up to #18 AWG (1.0 mm<sup>2</sup>).

### Environment

32 - 104 °F (0 - 40 °C). Relative humidity less than 90% non-condensing.

### Mounting

Typical backbox dimensions: 95 mm (3.74 in.) high, 55 mm (2.17 in.) wide, 70 mm (2.75 in.) deep.

<b>Job Name:</b>	<b>Model Numbers:</b>
<b>Job Number:</b>	

### Dimensions

Front View

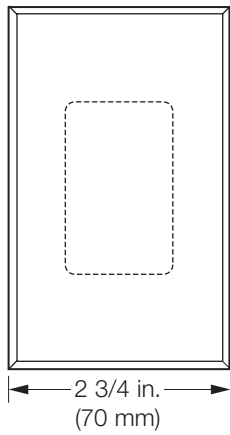

Side View

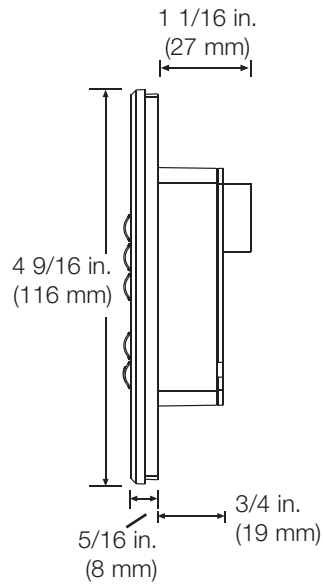

Back View

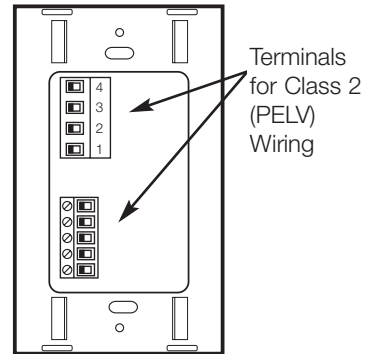

### Mounting

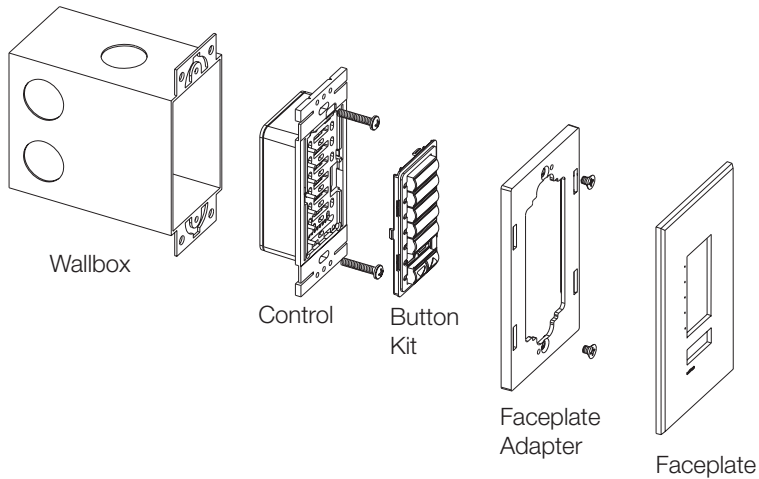

Job Name:	Model Numbers:
Job Number:	

## Color/Finish and Customizing Information

### Color/Finish

#### Matte Finishes

White	WH
Ivory	IV*
Beige	BE
Gray	GR*
Brown	BR
Black	BL

\* GR, IV not currently backlighted

#### Metal Finishes

With Black Plastic Buttons (Standard)

Bright Brass	BB
Bright Chrome	BC
Bright Nickel	BN
Satin Brass	SB
Satin Chrome	SC
Satin Nickel	SN
Antique Brass	QB
Antique Bronze	QZ

#### Gloss Finishes

Available with Insert (I) style controls only.  
Ship with Claro® faceplates.

White	GWH
Light Almond	GLA

#### Anodized Aluminum Finishes

Clear	CLA
Black	BLA
Brass	BRA

#### Backlighting Notes:

Illuminated text (translucent text on buttons) is available for these colors: BL and BR (including all metal finishes).

Illuminated buttons (with black text on buttons) are available for these colors: WH, BE, GR, WH\*, GLA\*.

\* Insert (I) style controls only

### Multi-gangung

- Order Insert (I) style controls.
- To order new Wallplates for multi-gangung, specify “R3” openings in a Lutron NovaT® multi-gang FB (fins broken) Series model number.

Examples:

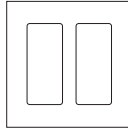

Wallplate for 2 seeTouch Wallstations, Model # NT-R3-R3-FB-(color)

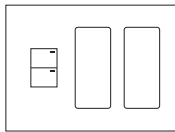

Wallplate for other Lutron controls and 2 seeTouch Wallstations, Model # NT-T8-R3-R3-FB-(color)

Note: New button inserts are not included with multi-gangung Wallplates.

### Button Replacement Kits

Use Button Replacement Kits to change: colors, button configuration, engraving, between insert and non-insert versions.

#### Non-Insert Kit

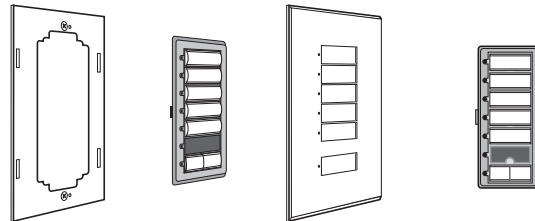

Each Kit includes an adapter, button assembly, and wallplate

#### Insert Kit

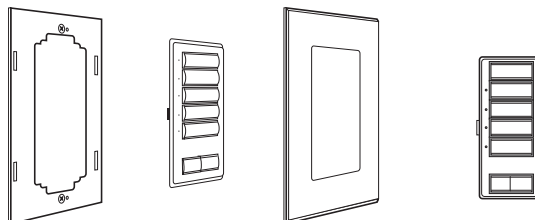

<b>Job Name:</b>	<b>Model Numbers:</b>
<b>Job Number:</b>	

# Wiring to Sivoia QED Window Treatments

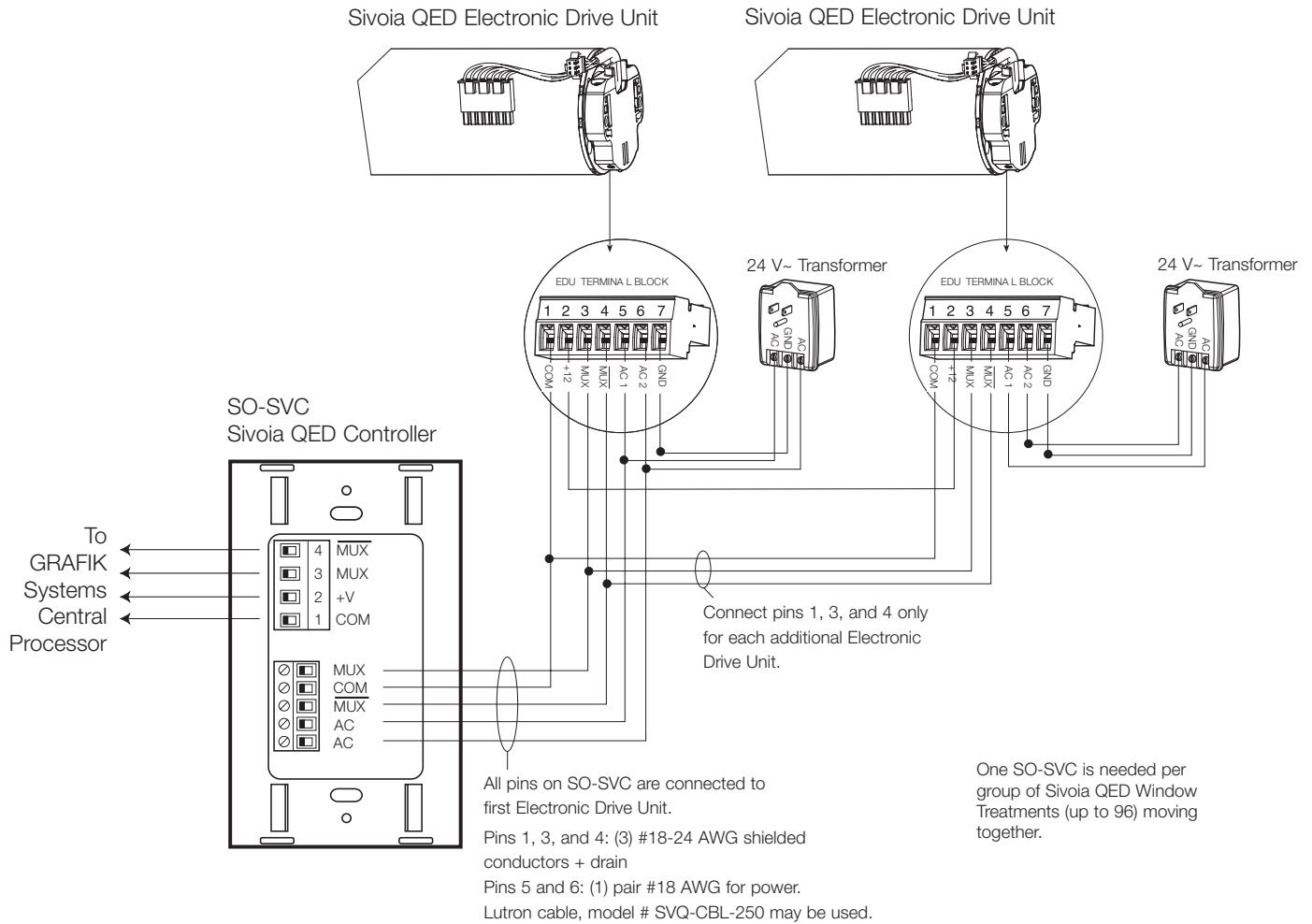

Refer to the Sivoia QED System instruction sheets for more information on programming Sivoia QED Electronic Drive Units.

**Notes:**

- Sivoia IR transmitters will not provide feedback to GRAFIK 5000/6000/7000 Central Processors.
- Use Sivoia keypads to control individual window treatments.

<b>Job Name:</b>	<b>Model Numbers:</b>
<b>Job Number:</b>	

## Low Voltage PELV (Class 2: USA) Wiring

- Use low-voltage PELV (Class 2: USA) wiring to daisy-chain Wallstations to GRAFIK Systems components.
- Make connections inside the wallbox or in a switchbox or junction box with a maximum wire length of 8 ft. (2.5 m) from the link to the Wallstation.
- Two #12 AWG (2.5 mm<sup>2</sup>) conductors for common (terminal 1) and 12 V<sub>DC</sub> (terminal 2). These will not fit in terminals. Connect as shown.
- One shielded, twisted pair #18 AWG (1.0 mm<sup>2</sup>) for data link (terminals 3 and 4).
- Connect Drain/Shield as shown. Do not connect to Ground (Earth) or Wallstation. Connect the bare drain wires and cut off the outside shield.

Note: Use appropriate wire connecting devices as specified by local codes.

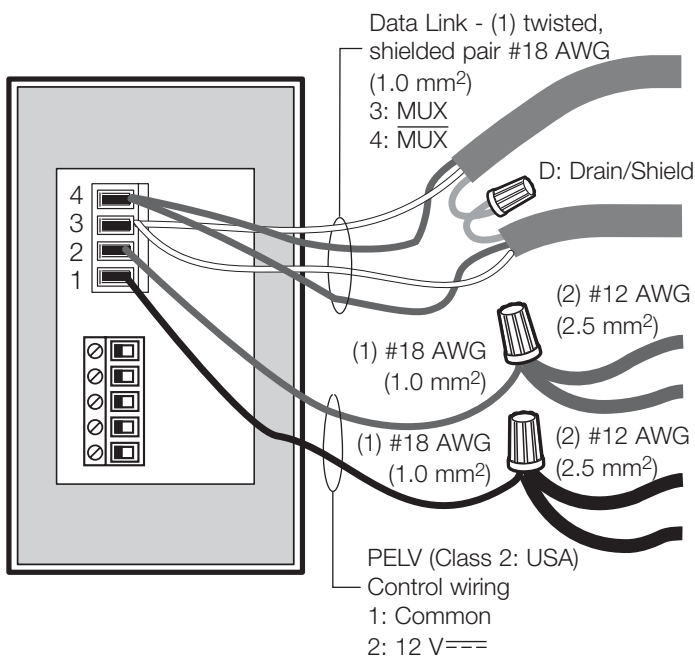

Job Name:	Model Numbers:
Job Number:	

## Low Voltage PELV (Class 2: USA) Wiring

### Sivoia QED Electronic Drive Unit Link

- Each SO-SVC may be wired in a daisy-chain, star, or t-tap configuration to connect up to 96 Sivoia QED Electronic Drive Units.
- Total length of wire on this link should not exceed 4000 ft. (1220 m). Power (24 V $\sim$ ) is supplied to the Sivoia QED Controller from the Sivoia QED Electronic Drive Unit's transformer.
- Each SO-SVC may be wired to only one group of Sivoia QED Electronic Drive Units.
- The Sivoia QED communication link should not be connected between groups of Electronic Drive Units controlled by separate Sivoia QED Controllers.
- Use seven conductors (four shielded #18 AWG, two power non-shielded #16 AWG, and one non-shielded #18 AWG with ground) Class 2. Lutron cable, model # SVQ-CBL-250, may be used.

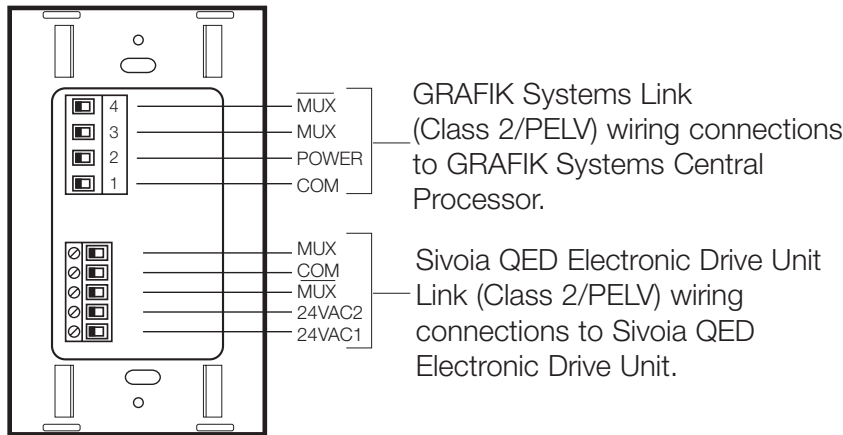

<p><b>Job Name:</b></p>	<p><b>Model Numbers:</b></p>
<p><b>Job Number:</b></p>	