

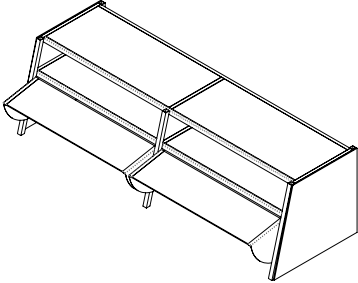

Your Solutions Partner

# Specifications

F.O.B Sedalia, Missouri 65301



TS-449-32

### OPTIONS:

- Full length Fluorescent light
- Special lengths
- Powder coat painted frames

**Approval Stamp(s):**

### PRODUCT INFORMATION:

PROJECT: \_\_\_\_\_

ITEM: \_\_\_\_\_

QUANTITY: \_\_\_\_\_

**MODEL:** Foodshield - Double Display Shelf

Fits: Thurmaduke, Insignia, Expressions Serving Systems

- TS-449-32
- TS-449-46
- TS-449-60 Traditional Glass Display Shelf
- TS-449-74
- TS-449-88

### SHELVES:

- 1/4" Tempered glass shelves
- Shelves hold pre-packaged products

### FRAMES:

- 1" square stainless steel tubing with welded corners
- Sloped front 1" square stainless steel tube legs

### GUARDS:

- Adjustable 1/4" tempered glass food shield
- Self-service one-sided style
- Clear acrylic enclosures both ends

### SIZES:

- All units available in following lengths  
31-1/2", 45-1/2", 59-1/2", 73-1/2", 87-1/2"

### Agency Listings:



**DUKE MANUFACTURING CO.**  
 2305 N. Broadway  
 St. Louis, MO 63102

**800.735.3853 Toll Free**  
**314.231.5074 Fax**  
**www.dukemfg.com**

### SHORT FORM SPECIFICATIONS:

#### Foodshield - TS449 Series Traditional Glass Display Shelves:

Constructed of 1" square stainless steel tube frames and uprights. Shelves constructed of 1/4" tempered glass. Food shield constructed of 1/4" thick glass with stainless steel edging. Fluorescent lights are available.

**NSF Updates:** (1) Removed upper guards (2) Changed lower bracket height and added radius (3) added new label to upper shelf

**FOODSHIELD - DOUBLE DECK**

- TS-449-32
- TS-449-46
- TS-449-60 Traditional Glass Display
- TS-449-74
- TS-449-88

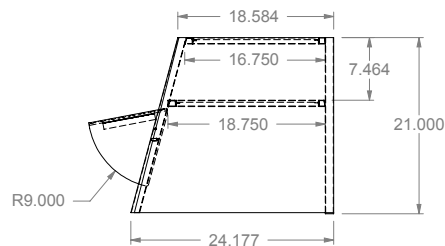
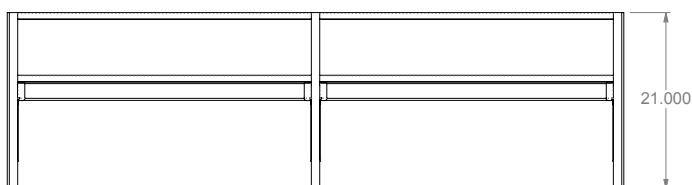
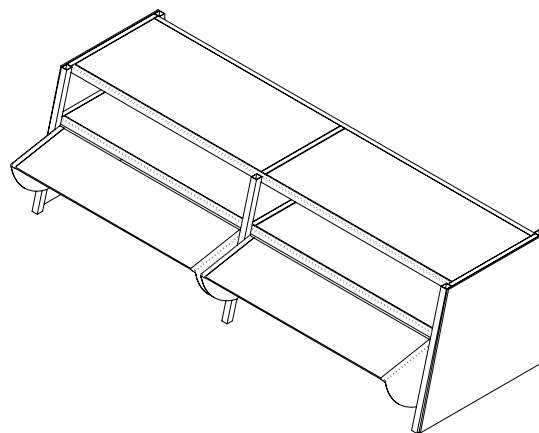
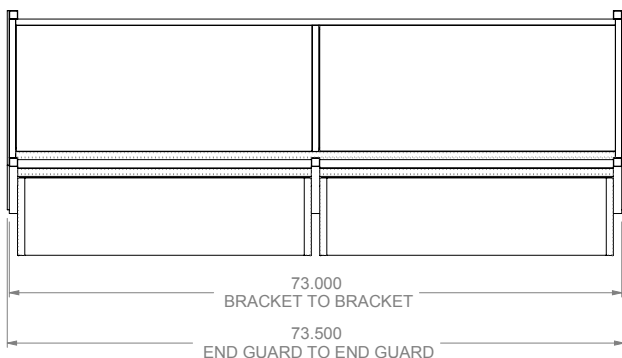

**DIMENSIONS:**

Traditional Glass Display

Freight Class: 125

Model	Length		Height		Width		Weight		Cube ft. Crated	Fluorescent light 120V / 1 Phase	
	in.	cm	in.	cm	in.	cm	lbs.	kg		Watts	Amps
TS-449-32	31	81.3	21	50.8	18-1/2	40.6	50	22.7	11.8	15	0.13
TS-449-46	45	116.8	21	50.8	18-1/2	40.6	65	29.6	16.3	15	0.13
TS-449-60	59	152.4	21	50.8	18-1/2	40.6	80	36.4	20.9	30	0.25
TS-449-74	73	188.0	21	50.8	18-1/2	40.6	100	45.5	27.0	30	0.25
TS-449-88	87	223.5	21	50.8	18-1/2	40.6	120	54.5	34.1	30	0.25



**DUKE MANUFACTURING CO.**

2305 N. Broadway  
St. Louis, MO 63102

800.735.3853 Toll Free  
800.231.1130 In Missouri  
314.231.5074 Fax  
www.dukemfg.com

Specification subject to change