

Access Transmission Solution

Mobile Backhaul



Cloud Services



Triple Play Services



Industry



Technology Park



Government



Data Center



Bank



Campus

iAccess™ Multi-Service Platform

- Mobile Fronthaul & Backhaul for 4G LTE
- 40G/10G Ethernet for Data Center Solution
 - Carrier Ethernet (NID & EDD)
 - CWDM & DWDM



iAccess™ Multi-Service Platform - FRM220 Series

In-Band Managed Multi-Service Platform-FRM220-CH20/08/04A



The FRM220 series is a multi-service chassis platform, which provides a reliable solution of high density media converter modules for applications such as telecom operator, enterprise, long haul transmission and factory automation. All of critical components of FRM220-CH20 and FRM220-CH08 chassis such as power modules, fans, management module and interface cards are hot swappable, allowing online field replacement. FRM220-CH04A is a fixed type AC, DC power built-in chassis. The available power options are built-in AC, DC power or built-in AC+DC, AC+AC, DC+DC redundant power.

FRM220 series is offered in three chassis densities, a 2U 20-slot (FRM220-CH20), a 1U 8-slot (FRM220-CH08), and a 1U 4-slot (FRM220-CH04A)

Feature

- Supports AC/DC power module hot swappable and power redundancy (CH20 & CH08)
- Supports fixed type AC/DC power built-in and power redundancy (CH04A)
- Two alarm relays contact for critical events warning
- Interface cards are hot swappable
- Chassis backplane consists of passive components

Specifications

Connectors	Console: RS232 (DB9), LAN 10/100Base-TX RJ45		Power	DC24	18~36VDC (CH20/CH08)
Physical Specifications	Dimensions (D x W x H)	303 x 438 x 88 mm (CH20)	DC48	36~75VDC (CH20/CH08)	
		310 x 440 x 44 mm (CH08)	AC	100~240V (CH04A)	
		170 x 310 x 44.7 mm (CH04A)	DC	18~75VDC (CH04A)	
Temperatures	Operating 0~60°C, Storage -10~70°C	Weight	Humidity	5%~90% non-condensing	
		5.2kg (CH20), 3.5kg (CH08) (w/o Power)	MTBF	65,000 hrs	
Power	AC	1.9kg (CH04AD), 1.5kg (CH04AC/DC)	Certification	FCC Class A, VCCI Class A, CE	
		100~240VAC (CH20/CH08)	Safety	UL 60950-1 (FRM220-CH20)	

iAccess Platform Solutions

iAccess™ Multi-Service Platform solutions offer a full range of solutions for service provider and enterprise, including high density 40G/16G connectivity, DWDM, CWDM, distance extension, Ethernet Switch/NID, Fiber Modem, Fiber Multiplexer and Media Converter. It is a fully modular product series that integrates a wide range of optical transport modules for any interface or protocol hosted in selection of Chassis size for simple and flexible operations.

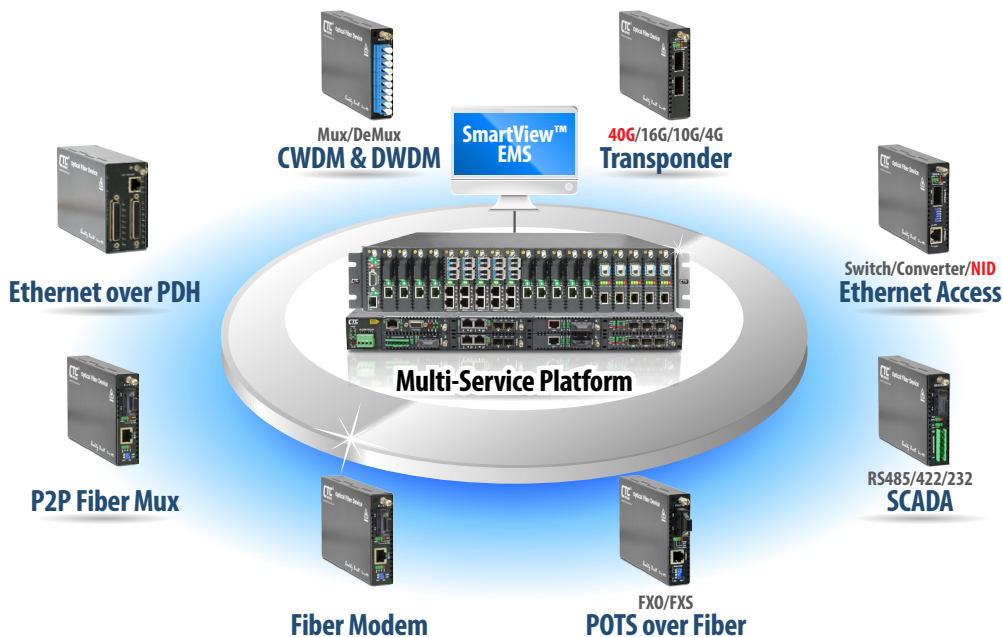

Main Features

- Module Cards for Deployment Scenarios

The FRM220-CH20, FRM220-CH08 and FRM220-CH04A have been designed as a Multi-service platform. This allows network administrators to deploy the chassis in a wide range of networks.

Technologies supported by the chassis include Fast/Gigabit Ethernet, E1/T1, V35/X21/RS-530, Serial RS-485/RS-422, Voice FXO/FXS, Repeater, Fiber Multiplexer, E1 Inverse Multiplexer, CWDM Mux/DeMUX and 10G/16G 3R Transponder

- Network Management

The FRM220-CH20, FRM220-CH08 and FRM220-CH04A require a NMC (Network Management Controller FRM220-NMC page: 2-3) card which must be installed into the first slot of chassis. The NMC card allows a network administrator the ability to configure and monitor the status of the blades. Management can be achieved locally over RS232, or over the network by Telnet, Web or SNMP. If the blades support Ethernet in the First Mile (IEEE 802.3ah), then the management module can also be monitored the status of a remote CPE.

Access Transmission Application

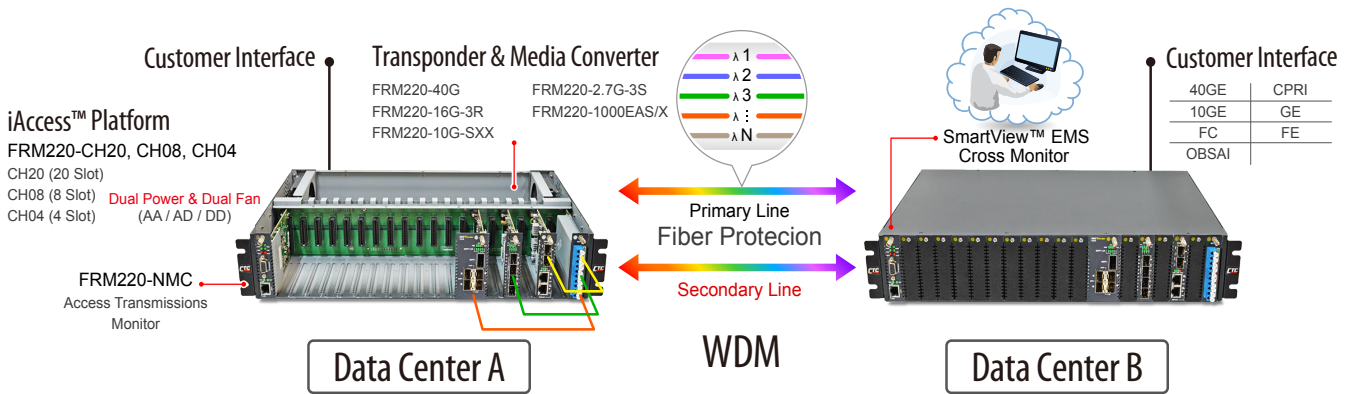

Chassis Overview

- FRM220-CH20 (2U 19" 20 Slots)

- FRM220-CH08 (1U 19" 8 Slots)

- FRM220-CH04A (1U 4 Slots)

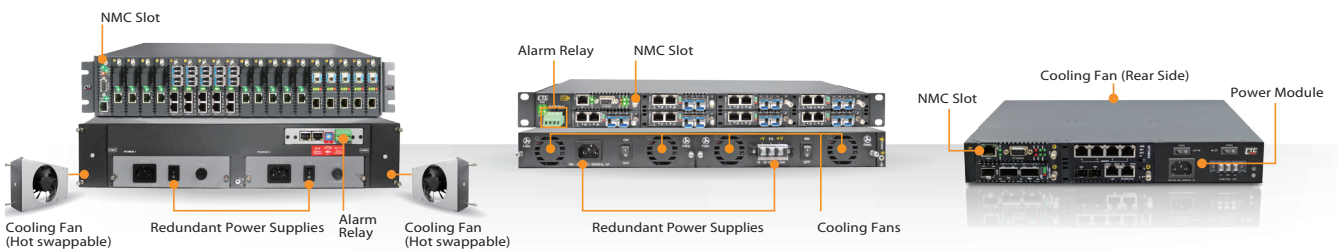

Ordering Information

Model Name	Type	Description
FRM220-CH20	Chassis	2U 20-Slot rack mount chassis with 20 line card blank plate
CH20-AC	Power	Chassis power module 100 ~ 240 VAC, IEC connector
CH20-DC24	Power	Chassis power module 18 ~ 36 VDC, 3 pin terminal block, 200W
CH20-DC48	Power	Chassis power module 36 ~ 72 VDC, 3 pin terminal block, 200W
FRM220-CH08	Chassis	1U 8 slots rack mount chassis with 8 line card blank plate, 200W
CH08-AC	Power	Chassis power module 100 ~ 240 VAC, IEC connector, 120W
CH08-DC24	Power	Chassis power module 18 ~ 36 VDC, 3 pin terminal block, 200W
CH08-DC48	Power	Chassis power module 36 ~ 72 VDC, 3 pin terminal block, 200W
CH04A-AC	Power	Four slot chassis with built-in AC power, 65W
CH04A-DC	Power	Four slot chassis with built-in DC power, 50W
CH04A-AD	Power	Four slot chassis with built-in AC+DC power (65W/50W)



FRM220-NMC

Network Management Controller

The FRM220-NMC is a Network Management Controller card that can be placed in a compatible FRM220 series chassis to provide device management functions. The management interface supports a local RS-232 serial console or remote TCP/IP management by Telnet, HTTP and SNMP protocols. The card is designed to be hot swapped so that it may be field replaced without affecting any online service of any other rack cards. The card also supports online firmware upgrade from TFTP server, using any user interface, without affecting any other inserted line card's transmissions. Support for any standard NMS is provided by the included enterprise MIB file. CTC Union also provides and maintains our own EMS (Element Management System) which is a Java based client/server manager for monitoring and maintaining a large number of network elements over a long period of time.

Feature

NMC provides central management for FRM220-CH20, FRM220-CH08, FRM220-CH04A and CH02-NMC

- User interfaces for serial console, Telnet & Web
- Configure, monitor and provide fault management for all installed line cards
- Monitor power and fan status in chassis
- Provides upgrade feature for most line card types
- SNMP agent for complete management by enterprise software
- Running System log with time stamping for SNTP (time server)
- Parameter management for quick configuration, configuration copy/backup/restore
- Card alias and inventory by type and serial number
- Linux Kernel based for high stability and reliability



◀ FRM220-NMC



(2U/19" rack mountable, 20 slots)

▪ FRM220-NMC must be installed in to the first slot of chassis.



◀ FRM220-NMC



(1U/19" rack mountable, 8 slots)



◀ FRM220-NMC



(1U, rack mountable, 4 slots)

The local area screen (Figure 1) is also the home page for the Web management of the NMC. An overview of all installed network interface cards (NIC) is shown with real-time status of LEDs. To enter the configuration screen for a NIC, simply click on the card.

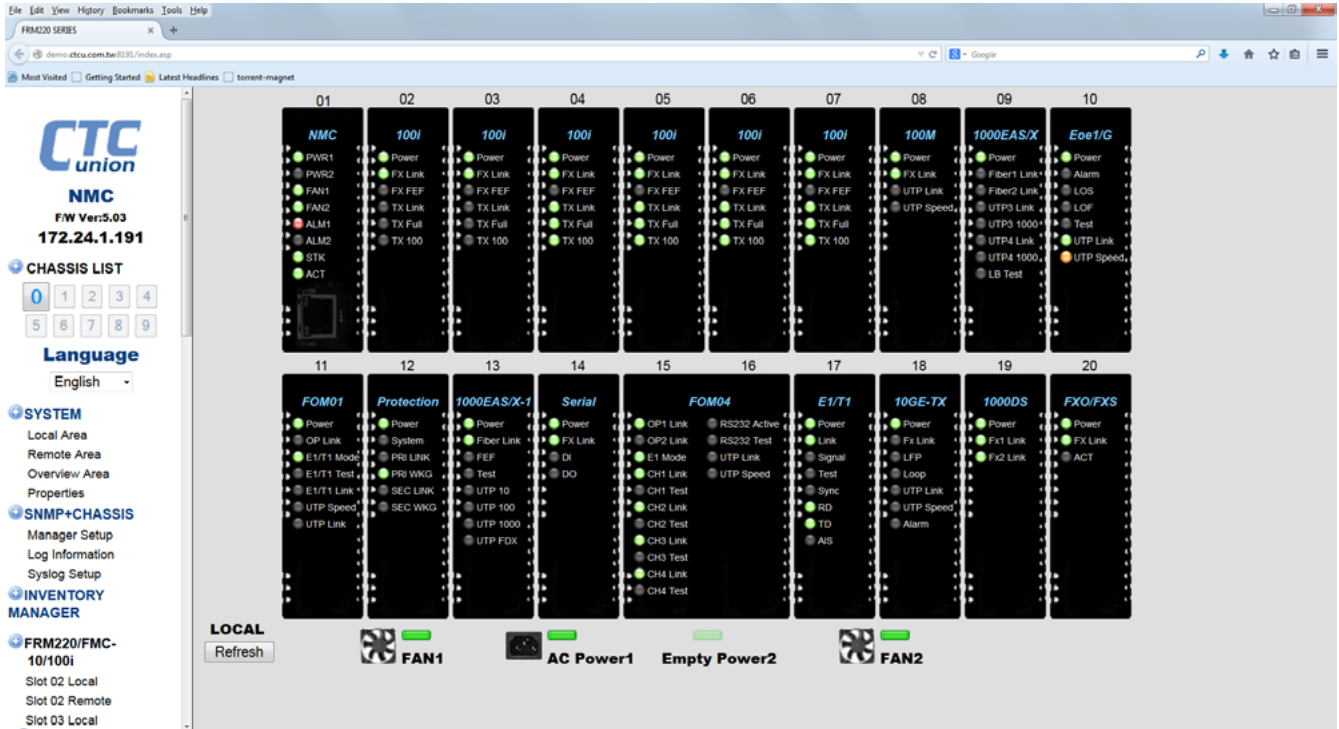

Figure 1

The SNMP+CHASSIS screen (Figure 2) gives a quick overview of the power and fan status in the chassis. This page is also used to assign the alarm conditions for the two programmable alarms. These alarms activate the electrical relays, display messages in the system log and can generate SNMP traps when a trap receiver is configured.



Figure 2

Network Management Controller

The system setting screen (Figure 3) has the functions for NMC upgrade, line card upgrade, system time and card parameter management.

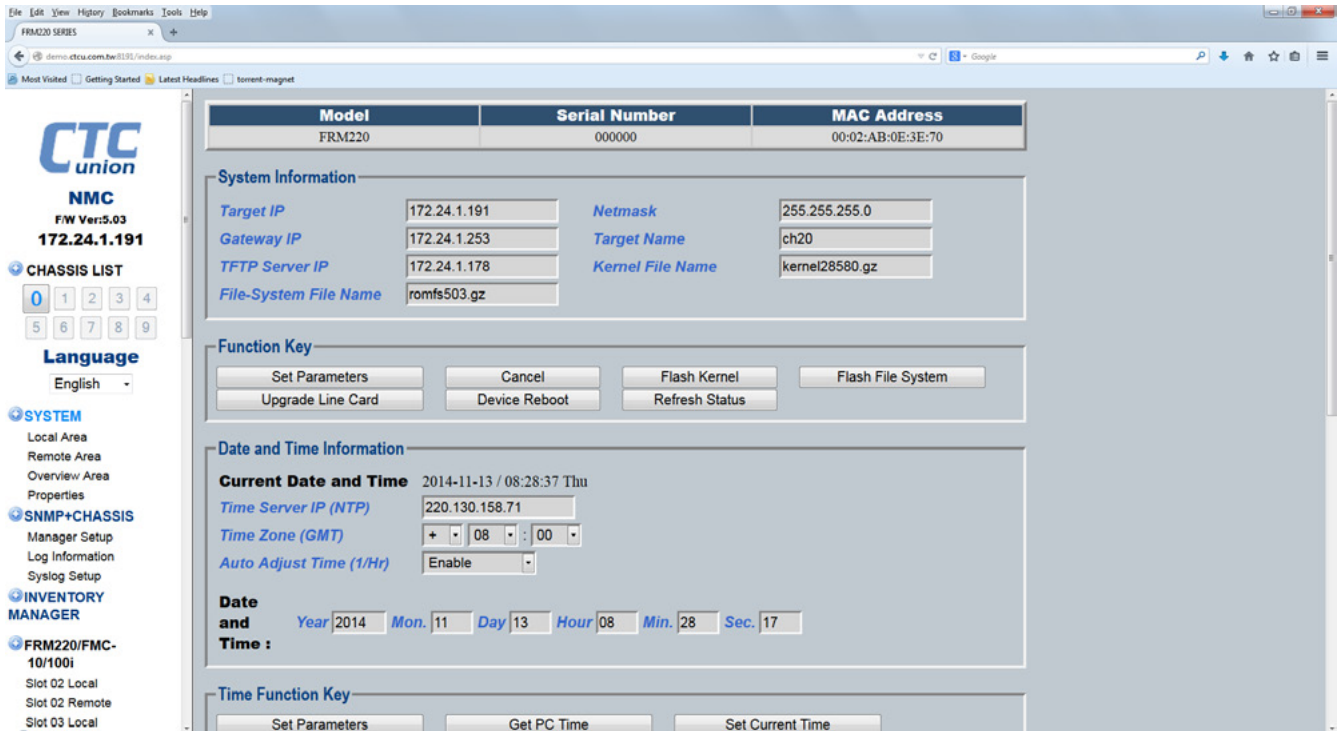

Figure 3

The management (Figure 4) can call up each line card to view detailed status and to make configuration changes to the card. By using a Web GUI, the settings can be made with simple mouse point and click actions.

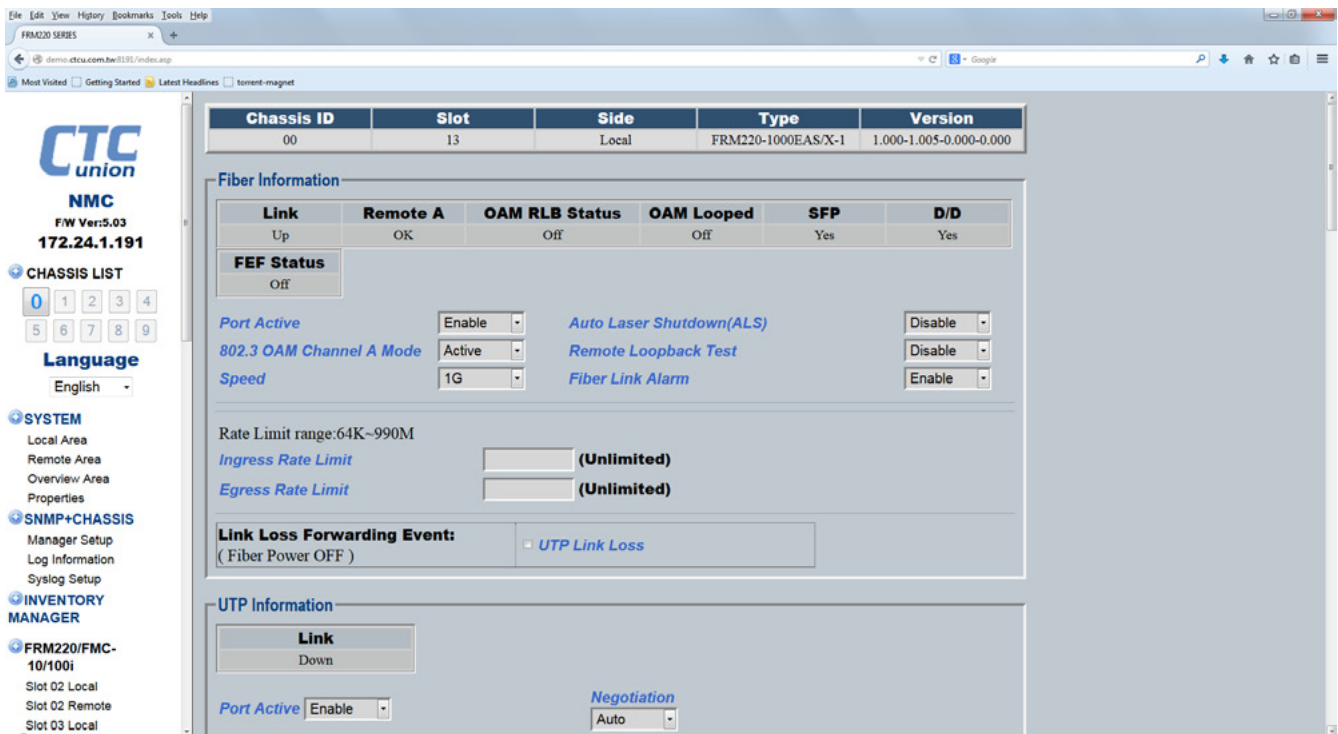

Figure 4

Ordering Information

Model Name	Type	Description
FRM220-NMC	Card	Network Management Controller card, support web, telnet, console, SNMP functions

Standalone Chassis for FRM220 Series

All of FRM220 series rack mount cards are hot-swappable and can be installed in a 20 slots (2U), or 8 slots (1U) rack-mountable chassis with any combination of redundant hot swappable AC, 24VDC or 48VDC power supplies, providing a scalable solution that is space-efficient and cost-effective. The rack mount cards can also be mounted in 4 slots, 2 slots, or 1 slot standalone housing with fixed AC/DC powered chassis.

The rack mount cards of FRM220 series provide telecommunication solutions for most applications. CTC union offers a universal and cost-efficient transmission series for a variety of fiber optic technologies (Multimode, Single mode, WDM, CWDM) starting from converters and switches, to modems and extending to intelligent voice/data multiplexer systems. The products are designed as rack mount cards in combination with various chassis types. The concept is to ensure an extremely variable mixture of products at low storage costs for spares.

Power Build-in Type

Power Build-in Type

FRM220-CH01



FRM220-CH01M

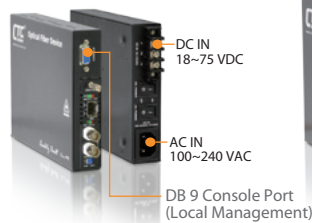

FRM220-CH02M & CH02M-2

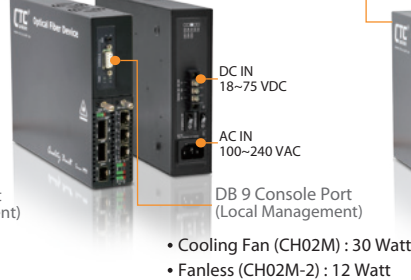

FRM220-CH02/NMC

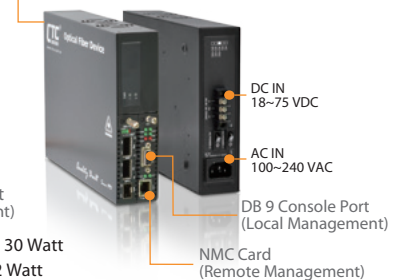

Adapter Type

FRM220-CH01



FRM220-CH02



Feature

- Fanless (CH01, CH01M, CH02, CH02M-2)
- Cooling Fan (CH02M, CH02/NMC)
- Supports DB9 console port for local management (CH01M, CH02M, CH02M-2)
- Telnet, Web, Console, SNMP management via NMC Card (CH02/NMC)

Power Type:

- External Power: DC12
- Internal Power: AC, DC, AD, AA or DD redundant power (option)

Standalone Chassis

Specifications

Power Input (Option)	External Adapter	Input Voltage 100~240VAC 50/60Hz
		Output Voltage 120VDC 1A
	Internal Power	AC: 100~240VAC
		DC: 18~75VDC
Weight	0.5~0.8kg (CH01) , 0.9kg (CH01M)	
	0.8kg (CH02), 1.3kg (CH02M), 1.2kg (CH02M-2), 1kg (CH02/NMC)	

Dimensions (D x W x H)	External Adapter	139x 23.2x 88mm (CH01)
		139x 44.5x 88mm (CH02)
	Internal Power	180x 30x 135mm (CH01)
		185x 30x 135mm (CH01M)
		222.7x 45.5x 167.4mm (CH02M, CH02M-2, CH02/NMC)

FRM220 Slide-In Card Chassis Order Information

Model Name	Description
CH01	1 Slot Chassis with 100 ~240VAC to 12VDC Adapter, Fanless
CH01-AC,DC,AD	1 Slot Chassis with AC: 100 ~240VAC DC: 18 ~72VDC or Dual Power (AC+DC), Fanless
CH01M-AC,DC,AD	1 Slot Chassis with Console port and AC: 100 ~240VAC, DC: 18 ~72VDC or Dual Power (AC+DC), Fanless
CH02	2 Slots Chassis with 100 ~240VAC to 12VDC Adapter, Fanless
CH02M-AC,DC,AD	2 Slots Chassis with Console port and AC: 30W 100 ~240VAC, DC:30W 18 ~72VDC or Dual Power (AC+DC), with Cooling Fan
CH02M-2-AC,DC,AD	2 Slots Chassis with Console port and AC:12W 100 ~240VAC, DC:12W 18 ~72VDC or Dual Power (AC+DC), Fanless
CH02/NMC (S)-AC,DC,AD	2 Slots Chassis with NMC card and AC:100 ~240VAC, DC:18 ~72VDC or Dual Power (AC+DC), with Cooling Fan

FRM220 – □□□□ – □□

Example: FRM220 – CH01 – AD

NEW



FRM220-40G-1Q4S

40G QSFP to 4x 10G SFP+ Transponder

2

40G Transponder

The FRM220-40G-1Q4S is a 40G QSFP to 4x 10G SFP+ transponder that provides media conversion and distance extension for 40G over 10G links. The FRM220-40G-1Q4S meets the growing need for more bandwidth for data centers and enterprises. The emergence of high-end servers and Ethernet switches with 40G Ethernet interfaces increases the need for media conversion (multi-mode to single-mode) and link range extension. The FRM220-40G-1Q4S is hot-swappable with one QSFP slot for QSFP 40G transceiver and four SFP+ slots for SFP+ 10G transceiver. The installation and setup is simple plug and play. The FRM220-40G-1Q4S can be inserted into any powered FRM220-CH20 chassis with QSFP and SFP+ transceivers required for the application.

Feature

- Network Management via FRM220 Chassis
- Multiple functions in one module: 40G converter/repeater and Quad 10G optical multiplexer
- 40G link interface --Ethernet/IEEE: 802.3ba 40GE-LR4
- 40G multi-link (fiber) interfaces --Ethernet/IEEE: 802.3ba XLAUI and OIF: CEI-11G
- Aggregate Data Rate: 10G x 4
- Data Rate per Lane: 8 ~ 14.2G
- QSFP ports for flexibility and scalability
- Hot-swap support (module and interfaces)
- Supports 1x 40G Mode and 4x 10G Modes
- Supports DMI function for QSFP fiber module
- Supports Loopback test function
- 3R function.

Specifications

Equipment function	3R Transponder, Regenerator, Reshaper, Retimer	Protocol	Ethernet 10G
Protocol	Multiple functions in one module: 40G converter/repeater—Quad 10G optical multiplexer 40G link interface	Interface Type	40Gbps : QSFP (1 port), 10Gbps : SFP+ (4 ports)
Aggregate Data Rate	32 - 56.8 Gbps	Transmission Distance	Up to QSFP module
Data Rate per Lane	8 - 14.2 Gbps	Power requirement	Power input 12VDC Power consumption: ≤12W
Ethernet/IEEE CPRI	802.3ba 40GBASE-LR4/SR4 x16	Work Environment	Operating Temperature 0 ~ 50°C Storage Temperature -10 ~ 70°C Humidity 10 ~ 90% (non-condensing)
STM	64	Dimension	Card: 155 x 23 x 88mm (D x W x H)
OC	192		
FC	8G, 10G, 16G		

Application

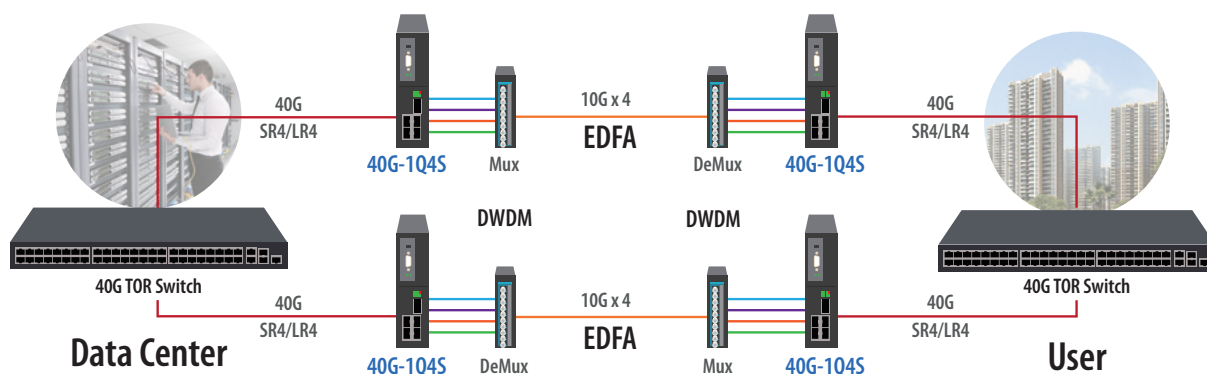

Ordering Information

Model Name	Description
FRM220-40G-1Q4S	40G converter/repeater, Quad 10G Optical Multiplexer module with QSFP Interfaces

Accessories

10G SFP+ Transceiver Module

SFM-1000-SR85	10G SFP+ SR/SW MMF 300m, 850nm VCSEL, 10G Ethernet/FC/SDH/SONET
SFS-1010-LR31	10G SFP+ LR/LW SMF 10km, 1310nm DFB DML, 10G Ethernet/FC/SDH/SONET
SFS-1040-ER55	10G SFP+ ER/EW SMF 40km, 1550nm DFB EML, 10G Ethernet/FC/SDH/SONET
SFS-1080-ZR55	10G SFP+ ZR/EW SMF 80km, 1550nm DFB EML, 10G Ethernet/FC/SDH/SONET



FRM220-16G-3R

16G 3R Multi-rate Transponder

The FRM220-16G-3R has 4 SFP+ slots that can be configured as a dual channel 16G 3R multi-rate transponder or in a 1-to-2 port protection mode. The device provides a flexible transmission of various protocols, such as 1G/10G Ethernet, SDH STM16/STM64, OTU1/OTU1e/OTU2/OTU2e, Fiber Channel 1/2/4/8/10/16, ODU, OBSAI, CPRI, etc. Using SFP+ ports with dedicated CWDM or DWDM wavelengths, the 16G transponder supports multi-rate functionality with optical data rates from 1Gbps up to 14Gbps. With its functionality the FRM220-16G-3R transponder is also suitable as a repeater for transmission over extended distances. In addition, the use of state of the art components greatly reduces the power requirements and heat dissipation factors over our previous transponders.

Feature

- Multi-rate supports 1Gbps ~ 14Gbps
- Protocol Transparent 3R fiber Media Transponder / Repeater
- Supports 1+1 Optical Line Protection
- Supports 2 channels with different bit rate.
- Supports Loopback Test.
- SFP DDM Information
- Firmware Upgrade
- Setting from DIP Switch, Console, NMC
- Supports FRM220 -CH01M, CH02M, CH04A, CH08, CH20
- FRM220-CH20, Full Load (19 Slots)

Specifications

Optical Interface	Connector	LC (SFP+, SFP)
	Wavelength	CWDM 1271 ~ 1611nm DWDM 1529.5~1565.50nm
Operation mode	Dual channel mode : Ch 1 SFP1 line / SFP2 client. Ch2 SFP3 line/ SFP4 client. Protection mode : SFP1 line / SFP2, SFP3 client	
Protocol	SONET	OC-24, OC-48, OC-192
	SDH	STM-16, STM-64
	Ethernet	1G, 2.5G, 10G
	OTU	OTU1, OTU1e, OTU2, OTU2e
	ODU	ODU1, ODU1e, ODU2, ODU2e
	OBSAI	OBSAI x1, x2, x4, x8
	CPRI	CPRI x1, x2, x4, x5, x8, x10, x16
	Fiber Channel	1/ 2/4/8/10/16 GFC
Regeneration	Re-Amplification, Re-Shaping, Re-Timing	

Indication	LED	Power, System, Mode, Test, FX1 Link, FX2 Link, FX3 Link, FX4 Link
Power	Input	12V / 1A
	Power Consumption	< 8W
Size	Dimensions	Card: 155 x 20.8 x 88mm (D x W x H)
	Weight	150g
Environment	Operating Temperature	0 ~ 50°C
	Storage Temperature	-10 ~ 70°C
	Humidity	10 ~ 90%
	Certification	CE, FCC
	MTBF	65000 hrs

Application

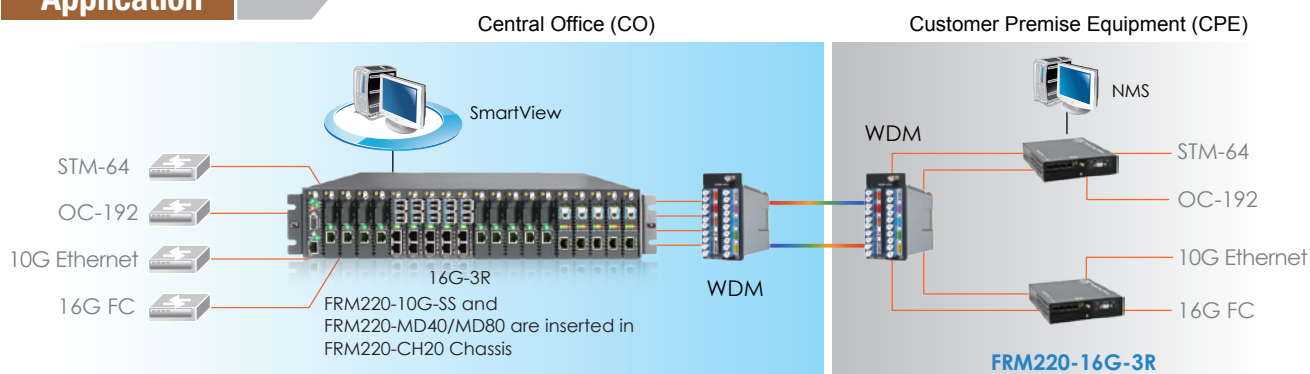

Ordering Information

Model Name	Description
FRM220-16G-3R	2 Channels 16Gbps 3R multi-rate transponder (optional SFP+)

Accessories

10G SFP+ Transceiver Module

SFM-1000-SR85	10G SFP+ SR/SW MMF 300m, 850nm VCSEL, 10G Ethernet/FC/SDH/SONET
SFS-1010-LR31	10G SFP+ LR/LW SMF 10km, 1310nm DFB DML, 10G Ethernet/FC/SDH/SONET
SFS-1040-ER55	10G SFP+ ER/EW SMF 40km, 1550nm DFB EML, 10G Ethernet/FC/SDH/SONET
SFS-1080-ZR55	10G SFP+ ZR/EW SMF 80km, 1550nm DFB EML, 10G Ethernet/FC/SDH/SONET

Note: This card may be placed in CH02M, CH01M or CH04A chassis with fan. For SNMP management, place this card in CH02/NMC or CH04A Chassis.

NEW



FRM220-10G-FEC

10G Ethernet FEC Multi-rate Transponder

FRM220-10G-FEC is a conversion module suitable for high-speed 10G signals with Forward-Error-Correction (FEC). The module supports four flexible SFP+ ports suitable for wavelength conversion and the transferring application for 10GbE and STM-64. The main field of FRM220-10G-FEC application is cost-optimized CWDM and DWDM networks. As an intelligent transponder module, the FRM220-10G-FEC converts a transparent data channel to a corresponding CWDM/DWDM wavelength. By means of the implemented 3R functionality (re-amplification, re-shaping, re-timing) for signal processing, the module is also suited for the use as a repeater. The data rates between 9.95Gbps and 11.32Gbps can be provided. Two types of housings are available for installation in a 19" FRM220 chassis. 20 slots are provided by using the FRM220-CH20 chassis 2U while the FRM220-CH08 1U supports up to 8 modules. Both housings can be monitored and configured through SNMP, Web GUI or Telnet using a NMC management module.

Feature

- Protocol transparent (9.95 – 11.32Gbps)
- 10Gbps signal repeating for 10GbE and STM-64
- 10Gbps conversion: Multimode, Single mode, CWDM, DWDM
- Future-proof and flexible SFP+ technology
- 3R functionality (Re-amplification, Re-shaping and Re-clocking)
- Low power consumption
- Wide range of applications
 - Dual OTN transponder or OTN repeater
 - Lambda conversion with FEC exchange
- Multiple clients data rate support
 - 10G Ethernet LAN/WAN PHY
 - 10G OC-192/ STM-64 SONET/SDH*
- Non OTN/FEC
 - 10G Ethernet LAN-PHY to LAN-PHY
 - 10G Ethernet LAN-PHY to WAN-PHY
- Per interface Forward Error Correction (FEC) encoding selection:
 - ITU-T G.709 Standard RS(255,239) (GFEC) – 6.2 dB
 - ITU-T G.975.1 Section I.7 Ultra-strong FEC with scaled - overhead (UFEC 7%) – 8.1 dB
 - ITU-T G.975.1 Section I.4 Ultra-strong FEC with scaled - overhead (UFEC 10%) – 8.3 dB
 - Zero FEC (wrapper done, FEC is zero)
 - No FEC (wrapper done, FEC is disabled)
- Comprehensive access performance monitoring
 - 10G Ethernet, 10G SONET/SDH*
- Comprehensive G.709 line and service performance monitoring
- Connection testing tools
 - Loopback
 - Notification or fault propagation
- SNMP management through NMC management module
- SFP+ transceivers for flexible configuration including DWDM
- SFP+ Digital Diagnostics

Specifications

General	1-slot module for integration in a FRM220 platform Operating temperature: 0°C – 40°C Dimensions (D x W x H): 155 x 88 x 23mm	Management	SNMP, Telnet and Web management using a NMC management module SFP+ management information provided by integrated DMI functions: input/output power, wavelength, bit rate, status, supported protocols, temperature
Interfaces	4x SFP+ ports (1 x line, 1 x client) Protocol : STM-64, 10G Ethernet Data rate: 9.92Gbps – 11.32Gbps depending on SFP+ type and application used	Housing Types	FRM220-CH08 1U 8-slot chassis FRM220-CH20 2U 20-slot chassis FRM220-CH02M, FRM220-CH02/NMC, 2-slot chassis
SFP+ Types	Optical (LC) 10Gigabit Ethernet (with or without FEC) STM-64 (with or without FEC) Multi-rate for 10Gigabit, STM-64 Wavelengths: 850nm, 1310nm, 1550nm, DWDM or tunable optics		

10G FEC Transponder

Application

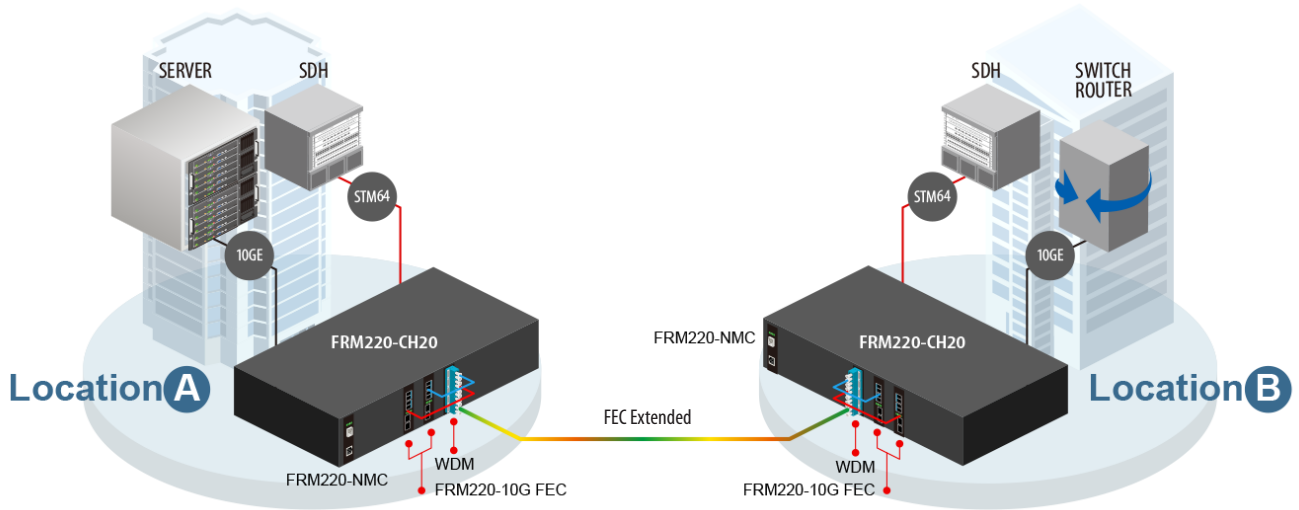

Ordering Information

Model Name	Description
FRM220-10G-FEC	10G Ethernet FEC Transponder

Note: This card MUST be placed in CH02M chassis with fan.
For SNMP management, place this card in CH02/NMC or CH04A Chassis.



FRM220-10G-SXX

10G 3R Multi-rate Transponder with Optical Line Protection

The FRM220-10G-SXX is a 10G fiber to fiber 3R repeater and transponder. Based on 10 Gigabit fiber standards, this transponder supports SFP+ to XFP (SX) or XFP to XFP (XX) fiber connections. 1+1 Automatic optical line Protection Switching is supported for the aggregate XFP fiber ports. The transponder is protocol transparent, providing 3R (Re-amplification, Re-shaping and Re-clocking) between these different optical module types. One of the major applications for this converter is in connecting proprietary transceiver equipment to CWDM or DWDM when these 'colored' optical modules are not available for the proprietary equipment. With transparent bi-directional forwarding capability between the 2 fiber media, the FRM220-10G-SXX brings you the best and simplest solution for your 10G conversion between fiber and fiber.

Feature

- Protocols Transparent at discrete bit rates of 1Gbps to 10Gbps
- Network management via Web, Telnet, SNMP in central FRM220-CH20 chassis (10 cards in chassis max.)
- Protocol transparent 3R fiber media transponder / repeater (Re-amplification, Re-shaping and Re-clocking)
- Promotes flexibility and eases management with pluggable SFP+ or XFP transceiver
- Features two 10G ports offering multiservice 10G transponder and regenerator function
- Supports 1+1 optical line protection
- Built-in self test (BIST) function
- Provides superior optics capabilities resulting in extended transport distances for regional application.
- Extend 10G Ethernet transmission over fiber useful as a 'Transponder' in CWDM or DWDM systems for 10G Ethernet/ Fiber Channel/STM-64
- Supports Client / Line loop back tests
- Serial console for stand-alone management when inserted in CH02M dual slot chassis
- XFP power supplies: +5.0V, -5.2V, +3.3V and +1.8V
- Supports reference clock output
- Supports 10G Tunable XFP module

Specifications

Optical Interface	Connector	LC	Power Input	12VDC
		1x Line SFP+ to 2x Client XFP 1x Line SFP+ to 1x Client XFP 1x Line XFP to 1x Client XFP		Power Consumption
	Protocol	OC-192/STM-64 (9.95328Gbps)	Dimensions	Card: 155 x 20.8 x 88mm (D x W x H)
		1 Gigabit Ethernet (1.25Gbps) 10 Gigabit Ethernet LAN(10.3125Gbps) G.709 OTU2 (10.709225Gbps) Fiber Channel 1x FC(1.062 Gbps); 2x FC(2.125 Gbps); 4x FC(4.25 Gbps); 8x FC(8.5 Gbps); 10xFC(10 Gbps)	Weight	150g
	Regeneration	Re-amplification Re-shaping, Re-timing	Temperature	0 ~ 50°C (Operating), -10 ~ 70°C (Storage)
Power	Loopback	Line / Client	Humidity	10 ~ 90% non-condensing
	Fiber	SM 9/125µm MM 50/125µm or 62.5/125µm	Certification	CE, FCC
	Wavelength	Depends on SFP+ or XFP	MTBF	65,000 hrs
Indications	LED (Power, Line Link, Client Link, Test, Loop back, Port Active, Alarm)			

Application

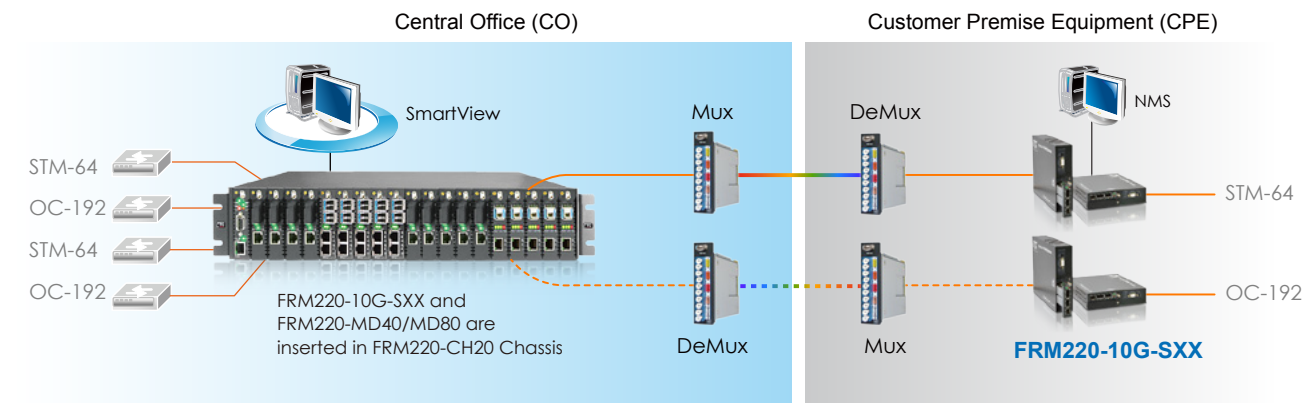

Ordering Information

Model Name	Description
FRM220-10G-SXX	10G 3R SFP+ to XFP fiber protection (optional SFP+, XFP module)

Accessories

10G XFP Transceiver Module

XFM-1000-SR85	10G XFP SR/SW MMF 300m, 850nm VCSEL, Ethernet / Fiber Channel only
XFS-1010-LR31	10G XFP LR/LW SMF 10km, 1310nm DFB DML, Ethernet/Fiber Channel/SDH/SONET
XFS-1040-ER55	10G XFP ER/EW SMF 40km, 1550nm DFB EML, Ethernet/Fiber Channel/SDH/SONET
XFS-1080-ZR55	10G XFP ZR/ZW SMF 80km, 1550nm DFB EML APD, Ethernet/Fiber Channel/SDH/SONET

10G SFP+ Transceiver Module

SFM-1000-SR85	10G SFP+ SR/SW MMF 300m, 850nm VCSEL, 10G Ethernet/FC/SDH/SONET
SFS-1010-LR31	10G SFP+ LR/LW SMF 10km, 1310nm DFB DML, 10G Ethernet/FC/SDH/SONET
SFS-1040-ER55	10G SFP+ ER/EW SMF 40km, 1550nm DFB EML, 10G Ethernet/FC/SDH/SONET
SFS-1080-ZR55	10G SFP+ ZR/EW SMF 80km, 1550nm DFB EML, 10G Ethernet/FC/SDH/SONET

Note: This card may be placed in CH02M or CH04A chassis with fan.
For standalone SNMP management, place this card in CH02/NMC or CH04A chassis.



FRM220-10G-SS

10G 3R Multi-rate Transponder

2

10G Transponder

The FRM220-10G-SS is a 10G fiber to fiber 3R repeater and transponder. Based on a number of 10 Gigabit Fiber standards, these transponders support SFP+ to SFP+ (SS) fiber connections. The transponders are protocol transparent, providing 3R (Re-amplification, Re-shaping and Re-clocking) regeneration between these different optical module types. One of the major applications for this converter is in connecting proprietary transceiver equipment to CWDM or DWDM when these 'colored' optical modules are not available for the proprietary equipment. With transparent bi-directional forwarding capability between the 2 fiber media, the FRM220-10G-SS brings you the best and simplest solution for your 10G conversion between fiber and fiber.

Feature

- Protocols Transparent at discrete bit rates of 1Gbps to 10Gbps
- Network management via Web, Telnet, SNMP in central FRM220 chassis(10 cards in chassis max.)
- Protocol transparent 3R fiber media transponder / repeater (Re-amplification, Re-shaping and Re-clocking)
- Promotes flexibility and eases management with pluggable SFP+ transceiver
- Features two 10G ports offering multiservice 10G transponder and regenerator function
- Provides superior optics capabilities resulting in extended transport distances for regional application.
- Extend 10G Ethernet transmission over fiber
- Useful as a 'Transponder' in CWDM or DWDM systems for 10G Ethernet/Fiber Channel/STM-64
- Supports Client / Line loop back tests
- Serial console for stand-alone management when inserted in CH02M Single Slot Chassis
- SFP+ power supplies: +3.3V

Specifications

Optical Interface	Connector	LC, 1x Line SFP+ to 1x Client SFP+	Power Input	12VDC							
	Protocol	OC-192/STM-64 (9.95328Gbps)		Power Consumption	< 12W						
		10 Gigabit Ethernet			Dimensions	Card: 155 x 20.8 x 88mm (D x W x H)					
		LAN(10.3125Gbps)				Weight	150g				
		G.709 OTU2 (10.709225Gbps)					Temperature	0 ~ 50°C (Operating), -10 ~ 70°C (Storage)			
		Fiber Channel						Humidity	10 ~ 90% non-condensing		
		1xFC (1.062 Gbps); 2xFC (2.125 Gbps)							Certification	CE, FCC	
		4xFC (4.25 Gbps); 8xFC (8.5 Gbps)								MTBF	65,000 hrs
		10xFC (10.51875 Gbps)									
		Regeneration									Re-amplification
		Re-shaping, Re-timing									
	Loopback	Line / Client									
	Fiber	SM 9/125µm									
		MM 50/125µm or 62.5/125µm									
Optical Interface	Wavelength	CWDM 1470 ~ 1610nm									
		DWDM 1529.55 ~ 1565.50nm									
Indications		LED (Power, Line Link, Client Link, Test, Loop back, Port Active, Alarm)									

10G Transponder

Application

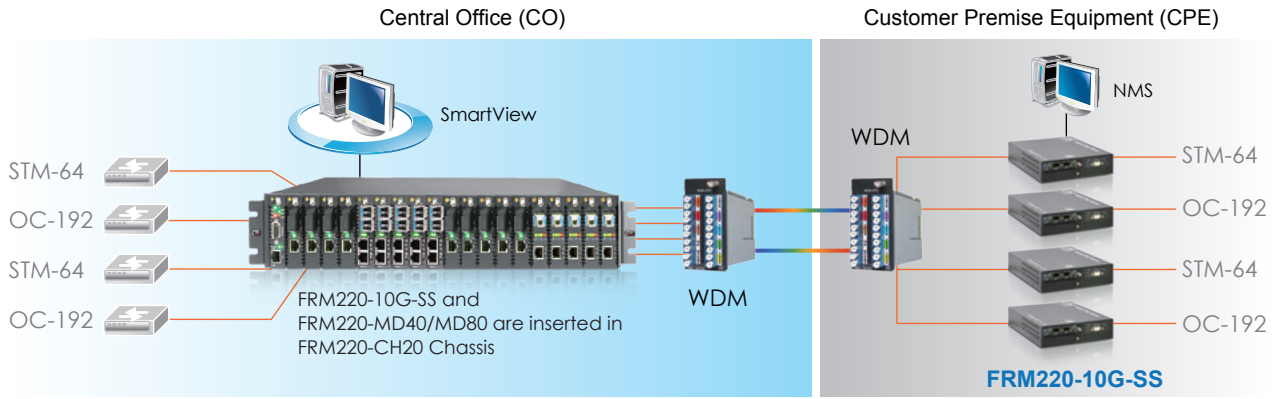

Ordering Information

Model Name	Description
FRM220-10G-SS	10G 3R transponder, SFP+ to SFP+ (optional SFP+ module)

Accessories

10G SFP+ Transceiver Module

SFM-1000-SR85	10G SFP+ SR/SW MMF 300m, 850nm VCSEL, 10G Ethernet/FC/SDH/SONET
SFS-1010-LR31	10G SFP+ LR/LW SMF 10km, 1310nm DFB DML, 10G Ethernet/FC/SDH/SONET
SFS-1040-ER55	10G SFP+ ER/EW SMF 40km, 1550nm DFB EML, 10G Ethernet/FC/SDH/SONET
SFS-1080-ZR55	10G SFP+ ZR/EW SMF 80km, 1550nm DFB EML, 10G Ethernet/FC/SDH/SONET

Note: This card may be set by DIP switch or console, but **MUST** be placed in CH02M chassis with fan. For SNMP management, place this card in CH02/NMC or CH04A Chassis.



FRM220-4G-3S

4G 2R Multi-rate Transponder with Optical Line Protection

The FRM220-4G-3S is a 2R 4G optical regeneration device, which consists of Re-amplification and Re-shaping. The transponder card converts a data signal to the correct wavelength for transmission on a specific channel by supporting SFP optics on both line side and client side interfaces. 1+1 Automatic optical line Protection Switching is supported for the aggregate fiber ports. When the FRM220-4G-3S card is placed in the FRM220 rack with SNMP management, the management can view the converter card's status, type, version, fiber link status and alarms. The card can be configured to enable or disable the port, reset the port and perform diagnostic loop backs.

Feature

- Multi-rate supports 28Mbps to 4.25Gbps
- Network management via Web, Telnet, SNMP in central FRM220 chassis
- Local configuration via DB9 console port (when placed in CH01M or CH02M)
- Digital diagnostic monitoring of SFP module
- Perform optical repeater function (Re-amplification, Re-shaping)
- Facility loopback on both Client / Line sides
- 1+1 optic fiber protection
- Link Fault Pass-Through (LFPT)
- Auto Laser Shutdown (ALS)
- Detect transceiver transmitter error alarm

Specifications

Optical Interface	Connector	SFP LC
	Protocol	OC -3, OC -6, OC -12, STM-1, STM-4, STM-16, FC -1, FC -2, FC -4
	Regeneration	Re-amplification Re-shaping
	Loop back	Line/Client
	Fiber	MM 62.2/125 μ m, 50/125 μ m. SM 9/125 μ m
	Wavelength	MM 850, 1310nm SM 1310, 1550nm WDM 1310T/1550R, 1550T/1310R CWDM 1470 ~ 1610nm
	Indications	LED (PWR, Line Link, Client Link, Test, Loop back, Port Active, Alarm)
Power Input	12VDC	
Power Consumption	< 12W	

Dimensions	Card: 155 x 20.8 x 88mm (D x W x H)
Weight	120g
Temperature	0 ~ 50°C (Operating), -10 ~ 70°C (Storage)
Humidity	10 ~ 90% non-condensing
Certification	CE, FCC
MTBF	65,000 hrs

Application

Managed 4G 2R Transponder with Fiber Protection

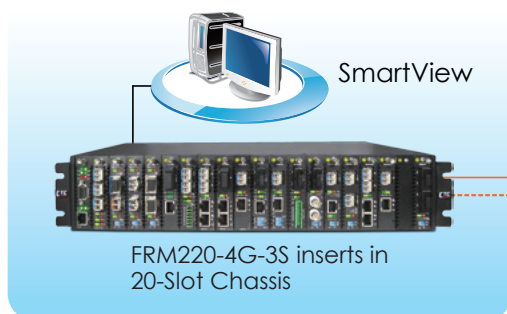

1+1 Fiber Protection



Protocols: Fast Ethernet, Gigabit Ethernet, OC-3, OC-6, OC-12, STM-1, STM-4, STM-16, FC-1, FC-2

4G Transponder

Ordering Information

Model Name	Description
FRM220-4G-3S	4G 2R Transponder with fiber protection, (optional SFP module)

Accessories

Multi-Mode 1.25Gbps SFP

SFM-7000-S85	1.25G SX, MM, 550m, 850nm, 8.5dB, 3.3V, LC
SFM-7000-S85-DD	1.25G SX, MM, 550m, 850nm, 8.5dB, 3.3V, LC, DD
SFM-7000-L31	1.25G LX, MM, 2km, 1310nm, 10dB, 3.3V, LC
SFM-7000-L31-DD	1.25G LX, MM, 2km, 1310nm, 10dB, 3.3V, LC, DD

Single-Mode 1.25Gbps SFP

SFS-7020-L31	1.25G LX, SM, 20km, 1310nm, 15dB, 3.3V, LC
SFS-7020-L31-DD	1.25G LX, SM, 20km, 1310nm, 15dB, 3.3V, LC, DD
SFS-7040-L31	1.25G LX, SM, 40km, 1310nm, 20dB, 3.3V, LC, DFB LD
SFS-7040-L31-DD	1.25G LX, SM, 40km, 1310nm, 20dB, 3.3V, LC, DFB LD, DD

Single Fiber 1.25Gbps SFP

SFS-7020-WA	1.25G WDM, 20km, Tx1310nm / Rx1550nm (A type), 3.3V, LC
SFS-7020-WA-DD	1.25G WDM, 20km, Tx1310nm / Rx1550nm (A type), 3.3V, LC, DD
SFS-7020-WB	1.25G WDM, 20km, Tx1550nm / Rx1310nm (B type), 3.3V, LC
SFS-7020-WB-DD	1.25G WDM, 20km, Tx1550nm / Rx1310nm (B type), 3.3V, LC, DD
SFS-7040-WA	1.25G WDM, 40km, Tx1310nm / Rx1550nm (A type), 3.3V, LC
SFS-7040-WA-DD	1.25G WDM, 40km, Tx1310nm / Rx1550nm (A type), 3.3V, LC, DD
SFS-7040-WB	1.25G WDM, 40km, Tx1550nm / Rx1310nm (B type), 3.3V, LC
SFS-7040-WB-DD	1.25G WDM, 40km, Tx1550nm / Rx1310nm (B type), 3.3V, LC, DD

Note: This card may be set by DIP switch and placed in CH02M chassis with fan, or set by serial console if placed in CH01M chassis



FRM220-2.7G-3S

2.7G Transponder (3R) with Optical Line Protection

The FRM220-2.7G-3S is a 3R 2.7G optical repeater and transponder, which consists of Re-amplification, Re-shaping and Re-timing. The transponder card converts a data signal to the correct wavelength for transmission on a specific channel by supporting SFP optics on both line side and client side interfaces. 1+1 Automatic optical line Protection Switching are supported for the aggregate fiber ports. When the FRM220-2.7G-3S card is placed in the FRM220 rack with SNMP management, the management can view the converter card's status, type, version, fiber link status and alarms. The card can be configured to enable or disable the port, reset the port and set the desired data rate to match the transmitted protocol.

Feature

- Multi-rate supports 34.3Mbps to 2.7Gbps
- Network management via Web, Telnet, SNMP in central FRM220 chassis
- Link Fault Pass-Through (LFPT)
- Auto Laser Shutdown (ALS)
- Local configuration via DB9 craft port In Stand-alone
- Digital diagnostic monitoring of SFP module
- Perform optical repeater function (Re-amplification, Re-shaping, and Re-clocking)
- Facility loopback on both Client / Line sides
- 1+1 optic fiber protection
- Dip switch setting data rate
- Detect transceiver transmitter error alarm

Specifications

Optical Interface	Connector	SFP LC	Indications	LED (PWR, Line Link, Client Link, Test, Loop back, Port Active, Alarm)
	Protocol	OC -3, OC -6, OC -12, OC-24, OC-48, STM-1, STM-4, STM-16, FC -1, FC -2		Power Input
Regeneration	Re-amplification	Power Consumption	< 12W	
	Re-shaping			
	Re-clocking			
Loop back	Line/Client	Dimensions	Card: 155 x 20.8 x 88mm (D x W x H)	
Fiber	MM 62.2/125μm, 50/125μm	Weight	120g	
	SM 9/125μm	Temperature	0 ~ 50°C (Operating), -10 ~ 70°C (Storage)	
Wavelength	MM 850, 1310nm	Humidity	10 ~ 90% non-condensing	
	SM 1310, 1550nm	Certification	CE, FCC	
	WDM 1310T/1550R, 1550T/1310R	MTBF	65,000 hrs	
	CWDM 1470 ~ 1610nm			

Application

Managed 2.7G 3R Transponder with Fiber Protection

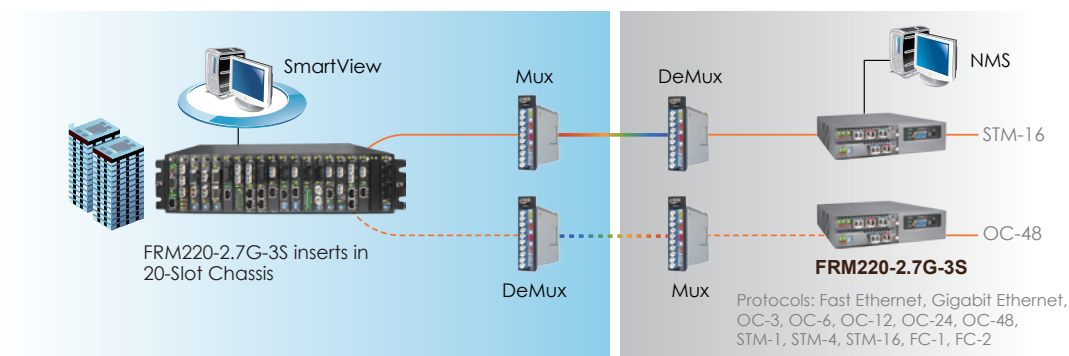

Ordering Information

Model Name	Description
FRM220-2.7G-3S	2.7G 3R Transponder with fiber protection, (optional SFP module)

Multi-Rate 2.67G SFP Module

SFM-9000-S85-DD	2.67G SX, MM, 300m, 850nm, 3.3V, LC, VCSEL (DD)
SFS-9002-L31-DD	2.67G LX, SM, 2km, 1310nm, 11dB, 3.3V, LC, FP (DD)
SFS-9015-L31-DD	2.67G LX, SM, 15km, 1310nm, 15dB, 3.3V, LC, DFB (DD)
SFS-9030-Z55-DD	2.67G ZX, SM, 30km, 1550nm, 15dB, 3.3V, LC, DFB (DD)
SFS-9050-Z55-DD	2.67G ZX, SM, 50km, 1550nm, 20dB, 3.3V, LC, DFB (DD)
SFS-9080-Z55-DD	1.25G WDM, 40km, Tx1310nm / Rx1550nm (A type), 3.3V, LC, DD
SFS-9100-Z55-DD	2.67G ZX, SM, 100km, 1550nm, 30dB, 3.3V, DFB (DD)

Note: This card may be set by DIP switch or console, but **MUST** be placed in CH02M chassis with fan. For SNMP management, place this card in CH02/NMC or CH04A Chassis.

NEW



FRM220-OAB15

Single Channel EDFA Booster NIC

The FRM220-OAB15 is a FRM220 chassis rack managed single channel Erbium Doped Fiber Amplifier (EDFA) booster line card for C-band. It has a large dynamic range while providing excellent broadband noise performance. It provides Automatic constant output Power Control (APC) and Automatic Constant Current (ACC) via rack management or RS-232 console interface. Its fast transient suppression feature allowing the output power to be kept constant level when there are fast changes in input power.

Feature

- Single channel EDFA with FRM220 chassis rack management
- Up to 15 dBm output power
- Output level constant control mode
- Output current constant control mode
- Low noise figure
- Low power dissipation

Applications

Booster Amplifier for 10Gbps, 40Gbps, and 100Gbps applications
Long haul C-band DWDM applications

Specifications

Parameter	Units	Specifications		Remarks
		Min.	Max.	
Wavelength Bandwidth	nm	1528	1562	
Input Power Range	dBm	-10	0	
Output Power Range	dBm		+15	@ Input Power = -6~0dBm
Noise Figure	dB		7.0	@ -6dBm input with 16dB gain
PDG	dB		0.5	
PMD	ps		0.5	
Power Consumption	W		2	
Operation Temperature	Degree C	-5	+70	
Storage Temperature	Degree C	-20	+70	
Transportation Temperature	Degree C	-40	+85	72 hrs max.
Dimensions	mm	155 x 88 x 23mm		

Application

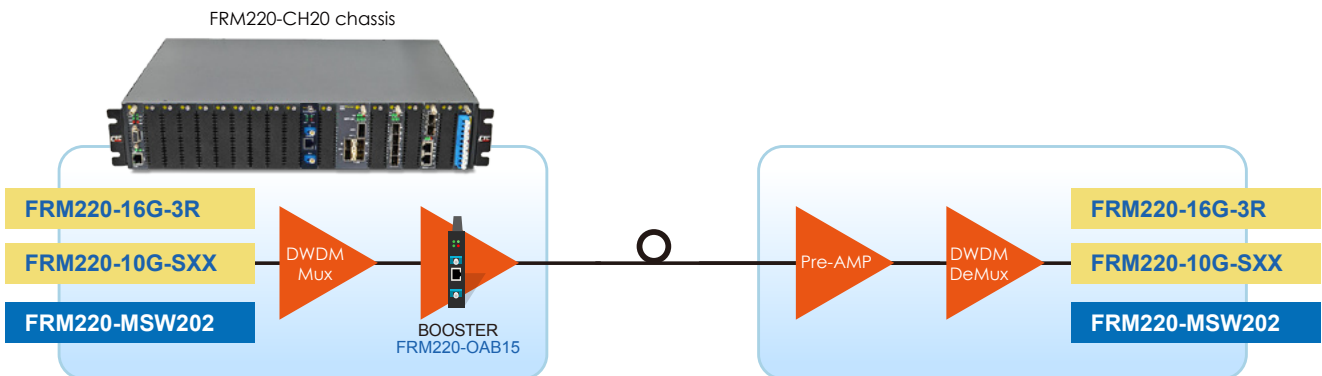

Ordering Information

Model Name	Description
FRM220-OAB15	FRM220 Chassis Single Channel EDFA Booster NIC

Naming Rule

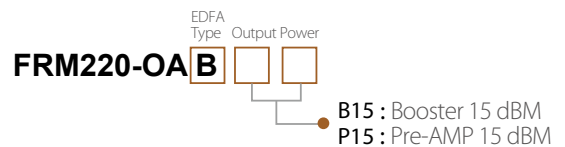



FRM220-DWDM

DWDM Mux/DeMUX

CTC Union DWDM MUX DEMUX Modules, with 100GHz channel spacing, can be used to combine or separate wavelength channels at standard ITU grid. We supply the common configuration including 4, 8, 16 channels. These DWDM modules passively multiplex the optical signal outputs from 4 or more electronic devices, and send them over a single optical fiber and then de-multiplex the signals into separate, distinct signals for input into electronic devices at the other end of the fiber optic link. All the DWDM MUX DEMUX modules provide excellent optical performance and high reliability to ease of fiber handling and power saving solution.

Feature

- Low Optical Insertion Loss
- High channel isolation
- Low PDL
- Good channel-to-channel uniformity
- Exceptional reliability and stability
- Reliable passive WDM optical technology
- Scales easily for ring networks
- Compliance with RoHS

Specifications

Item	100GHz DWDM	
	Mux	DeMux
Type		
Channel No.	4 / 8 / 16	
Center Wavelength, nm	Ch 21~60 or ITU Standard (specity)	
Channel Spacing, nm	0.8	
Channel Spacing, GHz	100	
Passband @0.5dB, nm	ITU ± 0.1	
Insertion Loss, dB for 4 channel	≤2.0	
Insertion Loss, dB for 8 channel	≤3.5	
Insertion Loss, dB for 16 channel	≤4.5	
Adjacent Channel Isolation, dB	N/A	≥25
Non-adjacent Channel Isolation, dB	N/A	≥35
Uniformity, dB	≤1.5 (Mux-DeMux Pair only)	
Directivity, dB	≥45	
Optical Input Return Loss, dB	≥45	
Polarization Dependent Loss, dB	≤0.15	
Polarization Mode Dispersion (PMD), ps	≤0.1	
Thermal Stability Drift, pm/°C	≤1	
Max. Optical Power, mW	300	
Max. Tensile Load, N	5	
Storage Temperature, °C	-40~85	
Operating Temperature, °C	0~70	

Application

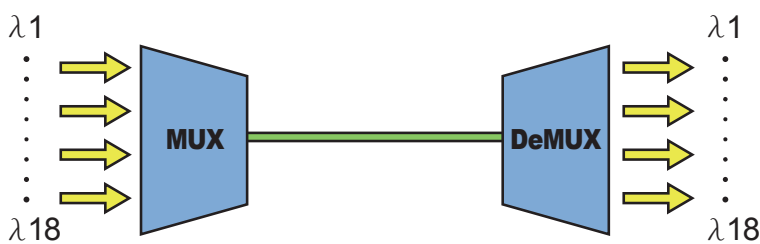

DWDM MUX must be used with DEDMUX on the other side

- Access networks
- Metro WDM systems
- Long haul WDM systems
- Enterprise networks
- Telecommunication
- Cellular Application
- Fiber optical amplifier
- Metro Network /Access Network/FTTH
- CATV fiber optic links

Ordering Information

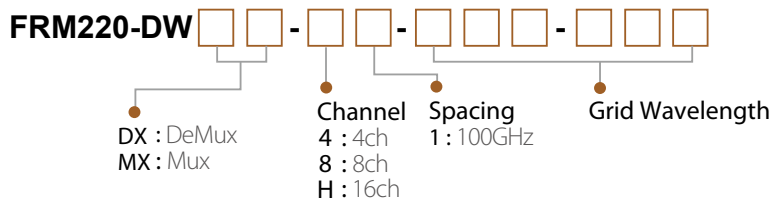

Model Name	Description
FRM220-DWab-cd-xxx-xxx	ab → DX : DeMux, MX : Mux c → 4: 4ch, 8: 8ch, H: 16ch d → 1 : 100GHz xxx → Grid wavelength

Please select all that apply from below list

100GHz Grid Wavelength

- D21 D22 D23 D24 D25 D26 D27 D28 D29 D30
 D31 D32 D33 D34 D35 D36 D37 D38 D39 D40
 D41 D42 D43 D44 D45 D46 D47 D48 D49 D50
 D51 D52 D53 D54 D55 D56 D57 D58 D59 D60

100GHz Grid Wavelength

Label	Frequency (THz)	Center Wavelength (nm)
D21	192.1	1560.61
D22	192.2	1559.79
D23	192.3	1558.98
D24	192.4	1558.17
D25	192.5	1557.36
D26	192.6	1556.55
D27	192.7	1555.75
D28	192.8	1554.94
D29	192.9	1554.13
D30	193.0	1553.33
D31	193.1	1552.52
D32	193.2	1551.72
D33	193.3	1550.92
D34	193.4	1550.12
D35	193.5	1549.32
D36	193.6	1548.51
D37	193.7	1547.72
D38	193.8	1546.92
D39	193.9	1546.12
D40	194.0	1545.32

D41	194.1	1544.53
D42	194.2	1543.73
D43	194.3	1542.94
D44	194.4	1542.14
D45	194.5	1541.35
D46	194.6	1540.56
D47	194.7	1539.77
D48	194.8	1538.98
D49	194.9	1538.19
D50	195.0	1537.40
D51	195.1	1536.61
D52	195.2	1635.82
D53	195.3	1535.04
D54	195.4	1534.25
D55	195.5	1533.47
D56	195.6	1532.68
D57	195.7	1531.90
D58	195.8	1531.12
D59	195.9	1530.33
D60	196.0	1529.55



Order Form

Example:

FRM220-DW M X - 4 1 - D 2 1 - D 2 4

↳ DWDM, Mux, 4 channels, 100GHz, 1560.61, 1559.79, 1558.98, 1558.17 Grid Wavelength

FRM220-DW - - -



Order Form

Example:

4ch:

FRM220-CW **M** **D** - **4** **2** - **A** **B** **C** **D**

↳ CWDM, Mux/DeMux, 4 channels, 1x upgrade port, 1271, 1291, 1311, 1331 Wavelength

FRM220-CW - -

8ch:

FRM220-CW **D** **X** - **8** **0** - **A** **B** **C** **D** **I** **J** **K** **L**

↳ CWDM, DeMux, 8 channels, Dual Fiber, 1271, 1291, 1311, 1331, 1471, 1491, 1511, 1531 Wavelength

FRM220-CW - -

16ch:

FRM220-CW **M** **X** - **H** **1** - **Z**

↳ CWDM, Mux, 16 channels, monitor port, 1271~1611 Wavelength

FRM220-CW - -

Please select all that apply from below list

A 1271 **B** 1291 **C** 1311 **D** 1331

E 1351 **F** 1371 **G** 1431 **H** 1451

I 1471 **J** 1491 **K** 1511 **L** 1531

M 1551 **N** 1571 **O** 1591 **P** 1611

.....
 Z All Wavelengths

NEW



FRM220-OPS51 FRM220-OPS52

Fiber Optical Protection Switch

2

Optical Protection Switch

FRM220-OPS Series are able to provide fiber path redundancy on a channel by channel basis. These units are particularly well suited for protection in any type of fiber data transmission. This solution includes monitoring capabilities for both the working and protected path fibers. In case of a fiber cut in the active path, traffic will be switched over to the protected path in less than 50ms (FRM220-OPS51) or 20ms (FRM220-OPS52). Monitoring is available through SNMP Management when both card is placed in FRM220 rack with SNMP management. The management can view the converter card's status, type, version, fiber link status and alarms. The card can be configured to enable or disable the port, reset the port, and configure receive threshold levels for path switching.

Feature

- Latch feature, if power is lost the switch remains in its current state
- Protection transition < 50 ms (FRM220-OPS51)
- Protection transition < 20 ms (FRM220-OPS52)
- Works with any combination of 1 ~16 wavelengths
- Traffic is switched in one of three modes : revertive,non-revertive, manual
- Programmable Rx threshold setting for switch-over
- Optical Interface Type : LC connectors
- Working and protected lines are physically separated fiber

Specifications

Connector	LC
LEDs	Power System, Working Path, Protection Path, Work mode
Power	DC 12V In
Operating Wavelength	1260 ~ 1620
Switch Type	2x1 / Latching
Input Power (Optical)	-35~-5dBm
Accuracy	≤ 0.5dBm
Insertion Loss	≤ 2.5 (Pair) (FRM220-OPS51), ≤ 5.5dB (FRM220-OPS52)
Return Loss	≥ 45dB
Cross-talk	≥ 60dB

Polarization Dependent Loss (PDL)	≤ 0.15dB
Input Power Sensitivity	-35dBm
Restoration Time	≤20ms
Power Consumption	< 6W
Dimensions	Card: 155 x 20.8 x 88mm (D x W x H)
Weight	130g
Temperature	0 ~ 50°C (Operating), -10 ~ 70°C (Storage)
Humidity	10 ~ 90% non-condensing
Certification	CE, FCC
MTBF	65,000 hours

Application

FRM220-OPS51 Working Theory

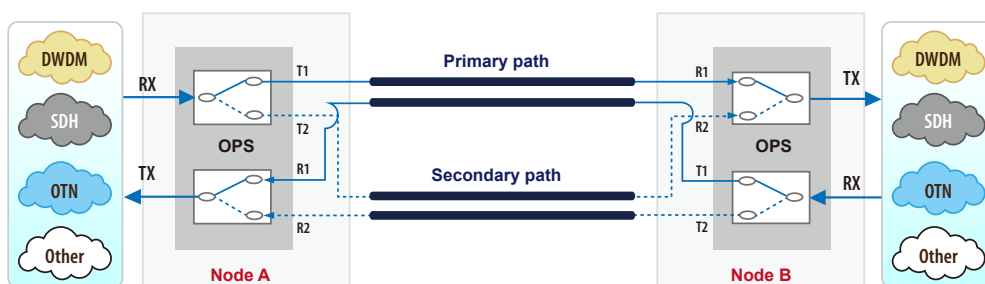

FRM220-OPS52 Working Theory

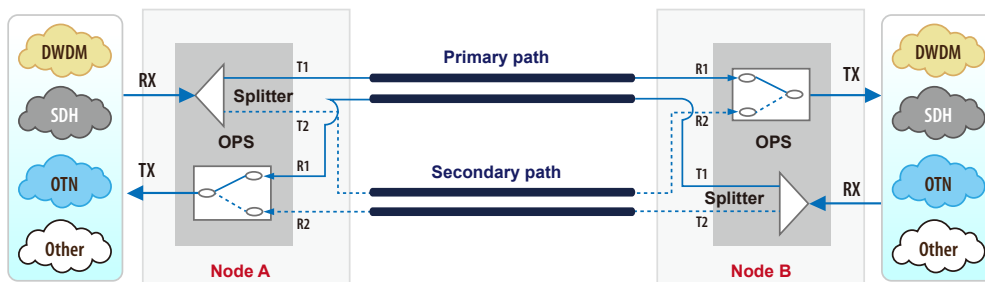

Ordering Information

Model Name	Description
FRM220-OPS51	Fiber Optical Protection Switch with LC/PC connector, OPS module inside
FRM220-OPS52	Fiber Optical Protection Switch with LC/PC connector, splitter inside

Note: This card must use CH01M, with serial console, to configure standalone settings. For SNMP management, place this card in CH02/NMC or CH04A Chassis.

Naming Rule

FRM220-OPS5



- Optical Switch Mode
- 1 : Splitter Inside
- 2 : OPS module inside



FRM220-10GC-TS

10G Base-T to 10G Base-R SFP+ Media Converter

The FRM220-10GC-TS is a copper to fiber 10G Ethernet media converter based on IEEE802.3an and IEEE802.3ae. With SNMP and Web-based management in the FRM220, the Network administrator can monitor, configure and control the activity of each card in the chassis. This converter uses Cat.6a/Cat 7 twisted pair cable as copper transmission media with RJ-45 and 10G optical solution with SFP+ LC connector. The data stream can be converted bi-directionally from 10G Base-T to 10G Base-R and vice versa. With full duplex wire speed forwarding capability between these two media, the FRM220-10GC-TS brings you the best and simplest solution for the 10G Ethernet conversion between copper wire and fiber.

Feature

- Network Management via FRM220 Chassis
- Complies with IEEE802.3an 10GBase-T and IEEE802.3ae 10GBase-R
- Real-Time conversion between 10GBase-T and 10GBase-R
- Common used SFP+ fiber interface and RJ45 connector
- Full duplex wire speed forwarding
- Forwarding 18k bytes jumbo packet
- Loopback Test
- Link Fault Pass Through
- Fiber Fault Alert
- IEEE 802.1q VLAN pass through
- Supports manual Dip Switch for quick set up

Specifications

Optical Interface	Connector	SFP+ LC
	Data rate	10.3125Gbps
	Distance	300m, 10km, 40km, 80km
	Wavelength	1550nm, 1310nm, 850nm, WDM
Electrical Interface	Connector	RJ45
	Data rate	10Gbps
	Cable type	Cat.6a, 7
	Distance	95 meters (Cat.7)
Management	Console port	RS-232 via CH01M, DIP Switch with CH01
Standards	IEEE 802.3an, IEEE 802.3ae	

LEDs	SFP+, LR, Link/Act, LBK A/B, SYS
Power	12VDC
Power Consumption	< 12W
Dimensions	Card: 155 x 20.8 x 88mm (D x W x H)
Weight	130g
Temperature	0 ~ 50°C (Operating), -10 ~ 70°C (Storage)
Humidity	0 ~ 85% non-condensing
Certification	CE, FCC
MTBF	57,000 hrs

Application

Central Office (CO)

Customer Premise Equipment (CPE)

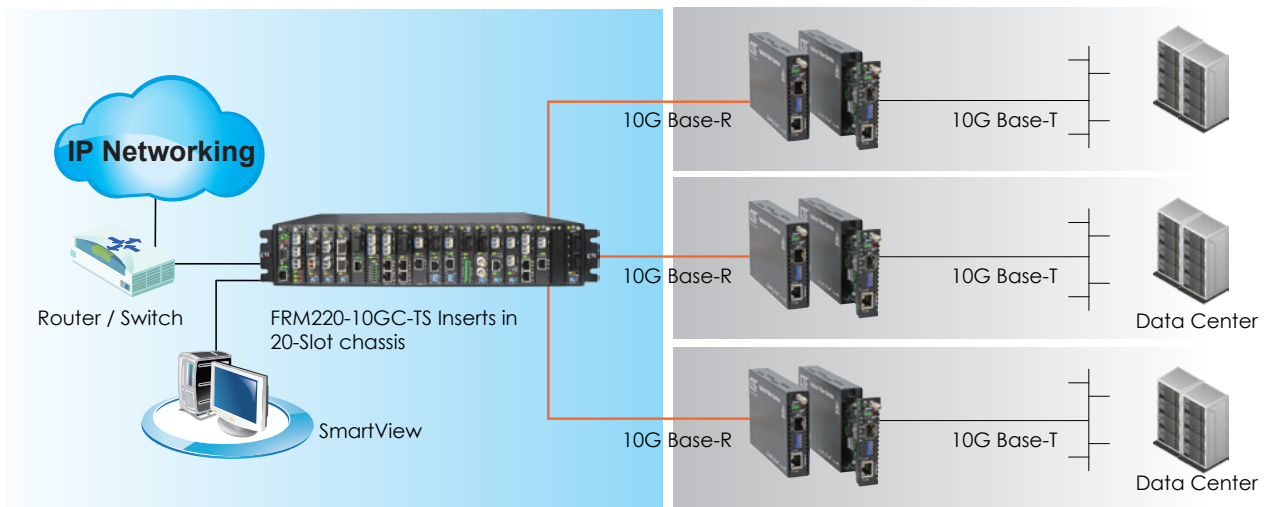

Ordering Information

Model Name	Description
FRM220-10GC-TS	10G Base-T RJ45 to 10G Base-R SFP+, with DIP switch (optional SFP+)



FRM220-MSW404

4x 10/100/1000Base-T + 4x 100/1000Base-X
L2+ Gigabit Carrier Ethernet Switch (NID)

2

Network Interface Device (NID)

The CTC Union's FRM220-MSW404 is the new generation of carrier grade Ethernet demarcation device for business connection and mobile backhaul transportation service delivered by carriers. The FRM220-MSW404 is equipped 4 SFP slots in dual rate 100/1000Base-X and 4 ports 10/100/1000Base-T RJ45 network interfaces. It is designed to enable E-Line, E-LAN, E-Tree services which are CE (Carrier Ethernet) 2.0 compliant for Metro Ethernet network deployments.

The FRM220-MSW404 device enables carriers and service providers to delivered SLA-based network service with extensive fault detection and diagnostic capabilities which are compliant with the latest Ethernet OAM standards such as IEEE 802.3ah, IEEE 802.1ag and ITU-T Y.1731. With built-in RFC2544 feature sets, The FRM220-MSW404 also enables the service providers to perform the SLA verification anytime to ensure the quantitative latency, jitter and throughput delivery performance indexes. The CE2.0 compliant functions support EVCs and 3 colors marker QoS traffic management to enable service providers managing bandwidth and enforce SLA guaranteed. This card may be controlled and monitored via an NMC in a managed chassis or used as a completely manageable device when used stand-alone. Stand-alone management supports Telnet/SSH, HTTP/HTTPS and SNMP v1, v2C or v3.

Feature

- The next generation of Ethernet demarcation device, at customer premise, fulfilling the large-scale carrier Ethernet deployment for intelligent business connection and mobile backhaul services complied to CE 2.0 standard.
- CE2.0 standards compliant product guarantees the fully interoperability with other MEF certified equipment and reduces the risks and cost of Carrier Ethernet network deployment for operators and service providers.

Specifications

Interface	100/1000Mbps SFP slots x 4 + 10/100/1000Base-T RJ45 x 4	SNMP Agent	SNMP v1/v2c/v3, RMON Group 1,2,3 and 9
Filter & Forward Rate	14880pps at 10Mbps, 148800pps at 100Mbps, 1488000pps at 1Gbps	Software Upgrade	TFTP/HTTP
Switching Fabric Capacity	16Gbps	Ethernet OAM	IEEE 802.3ah, IEEE 802.1ag, ITU-T Y.1731, RFC2544
Transmission Method	Store and Forward Switching	LED Display	Power, System, Console, Link, Speed/Act
Standard	IEEE 802.3u, IEEE 802.3z, IEEE 802.3ae, IEEE 802.3x, IEEE 802.1p, IEEE 802.1Q, IEEE 802.1ad, IEEE 802.1D, IEEE 802.1w, IEEE 802.1s, IEEE 802.1x, IEEE 802.3ad	Power Input	100V ~ 240VAC, -18 ~ -72VDC
Packet Buffer	8M bits	Power Consumption	< 20W
MAC Table Size	8K	Operating Temperature	0 ~ 50°C
Max. Packet Size	10K Bytes	Humidity	5% ~ 90% (non-condensing)
VLAN Feature	IEEE 802.1Q tagged VLAN(Max. 4K VLAN groups), port based VLAN, MAC based VLAN, protocol based VLAN, private VLAN, IEEE 802.1ad Q-in-Q, VLAN Translation, GVRP	Dimensions	Card: 155 x 42.1 x 88 mm (D x W x H)
QoS Feature	IEEE 802.1p 8 priority queues per port, CoS based on switch port; VLAN ID; DSCP; TCP/UDP port, IEEE 802.1p priority tag remarking, DSCP remarking, Port based ingress/egress rate limit 3 colors marker-CIR/EIR/Burst bandwidth control	Regulatory	FCC, CE
L2 switching protection	STP, RSTP, MSTP, ITU-T G.8031/G.8032 Ethernet ring protection		
Trunking	IEEE 802.3ad LACP(Max. 4 trunking group, Max. 8 ports per trunking group)		
Security	IEEE 802.1x port based access control, MAC based access control authentication, RADIUS authentication, limited MAC address learning, IP/MAC binding, ACL rule based filtering, TACACS+, IP source guard, DHCP snooping/relay option 82, ARP inspection		
IP Multicasting	IGMP throttling, IGMP filtering, IGMP fast leave, IGMP snooping v1/v2/v3, MVR, MLD snooping v1/v2		
Storm Control	Unicast/Broadcast/Multicast storm suppression		
Management	Web/Telnet CLI/SNMP/console interface, Web/CLI authentication, SSH v2, HTTPS, port mirroring, syslog, IPv6 management, NTP, SNTP		

Application

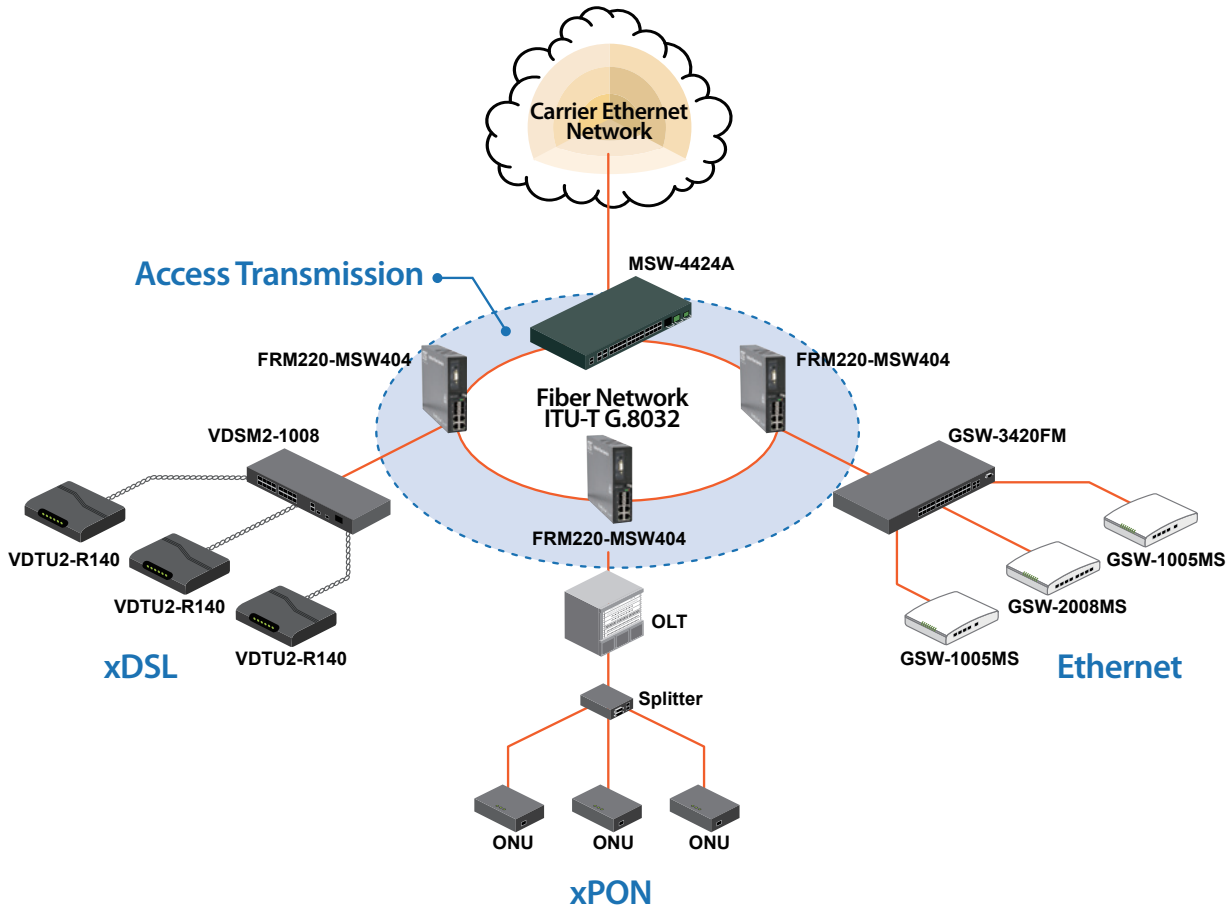

- Carrier Ethernet with multiple class of service
- Traffic Synchronization
- Precisely delivery of time-sensitive service

Ordering Information

Model Name	Description
FRM220-MSW404	4 x SFP Slots in Dual Rate 100/1000Base-X and 4x 10/100/1000Base-T RJ45 OAM Managed Carrier Ethernet Switch

FRM220 – MSW404
 Example: FRM220 – MSW404

Note: To Support Console Interface managed, this card must be placed in CH02M chassis.

- Standalone type is available. Please refer to page :



FRM220-MSW202

2x 10/100/1000Base-T + 2x 100/1000Base-X
L2+ Gigabit Carrier Ethernet Switch (EDD)

FRM220-MSW202 is a carrier class Ethernet Demarcation Device (EDD) with 2 x 10/100/1000Base-T Ethernet ports and 2 x 100/1000Base-X dual rate SFP fiber ports which enables EPL (Ethernet Private Line) & EVPL (Ethernet Virtual Private Line) services with advanced carrier Ethernet features per the Metro Ethernet Forum (MEF 9 and 14). By supporting link and service Ethernet OAM schemes, the FRM220-MSW202 also provides extensive fault detection and diagnostic capabilities to ensure that actual network use complies with pre-agreed service level agreements (SLAs). This card may be controlled and monitored via an NMC in a managed chassis or used as a completely manageable device when used stand-alone. Stand-alone management is supported by Telnet/SSH, HTTP/HTTPS and SNMP v1, v2C or v3.

Feature

- Complies with MEF CE1.0
- Supports 8K MAC
- Spanning Tree 802.1D, 802.1s, 802.1w
- Supports 802.1Q / 4K active VLANs
- Double VLAN Tagging (C-tag/S-tag) (IEEE 802.1ad) support for ISP application
- Various QoS capability (MAC/port/802.1p/Diffserv)
- Port-based rate limiting
- DHCP Snooping
- IGMP Snooping
- IPv6 support
- IEEE 802.3x and IEEE 802.1x support
- Jumbo frame for up to 9.6K
- Extensive Ethernet OAM support
- IEEE 802.3ah, IEEE 802.1ag, ITU-T Y.1731
- SNMP v1/v2c/v3, Telnet, Web GUI
- IEEE 1588 V2 aware (Optional)

Specifications

Interface	100/1000Mbps SFP slots x 2 + 10/100/1000Base-T RJ45 x 2	Management	Web/Telnet CLI/SNMP/console interface, Web/CLI authentication, SSH v2, HTTPs, port mirroring, syslog, IPv6 management, NTP, SNTP, sFlow
Filter & Forward Rate	14880pps at 10Mbps, 148800pps at 100Mbps, 1488000pps at 1Gbps	SNMP Agent	SNMP v1/v2c/v3, RMON Group 1,2,3 and 9
Switching Fabric Capacity	8Gbps	Software Upgrade	TFTP/HTTP
Transmission Method	Store and Forward Switching	Ethernet OAM	IEEE 802.3ah, IEEE 802.1ag, ITU-T Y.1731
Standard	IEEE 802.3u, IEEE 802.3z, IEEE 802.3ab, IEEE 802.3x, IEEE 802.1p, IEEE 802.1Q, IEEE 802.1ad, IEEE 802.1D, IEEE 802.1w, IEEE 802.1s, IEEE 802.1x, IEEE 802.3ad, IEEE802.3ah, IEEE802.1ag, ITU-T Y.1731, ITU-T G.8031, ITU-T G.8032	LED Display	Power, System, Console, Link, Speed/Act
Packet Buffer	4M bits	Power Input	100V ~ 240VAC, -18 ~ -72VDC
MAC Table Size	8K	Power Consumption	< 12W
Max. Packet Size	9.6K Bytes	Operating Temperature	0 ~ 50°C
VLAN Feature	IEEE 802.1Q tagged VLAN(Max. 4K VLAN groups), port based VLAN, MAC based VLAN, protocol based VLAN, private VLAN, IEEE 802.1ad Q-in-Q, VLAN translation, GVRP	Humidity	5% ~ 90% (non-condensing)
QoS Feature	IEEE 802.1p 8 priority queues per port, CoS based on switch port; VLAN ID; DSCP; TCP/UDP port, IEEE 802.1p priority tag remarking, DSCP remarking, Port based ingress/egress rate limit, 3 colors marker-CIR/EIR/Burst bandwidth control	Dimensions	Card: 201 x 135 x 35 mm (D x W x H)
L2 switching protection	STP, RSTP, MSTP, ITU-T G.8031/G.8032 Ethernet ring protection	Regulatory	FCC, CE
Trunking	IEEE 802.3ad LACP(Max. 2 trunking group, Max. 4 ports per trunking group)		
Security	IEEE 802.1x port based access control, MAC based access control authentication, RADIUS authentication, limited MAC address learning, IP/MAC binding, ACL rule based filtering, TACACS+, IP source guard, DHCP snooping/relay option 82, ARP inspection		
IP Multicasting	IGMP throttling, IGMP filtering, IGMP fast leave, IGMP snooping v1/v2/v3, MVR, MLD snooping v1/v2		
Storm Control	Unicast/Broadcast/Multicast storm suppression		

Ethernet Demarcation Device (EDD)

Application

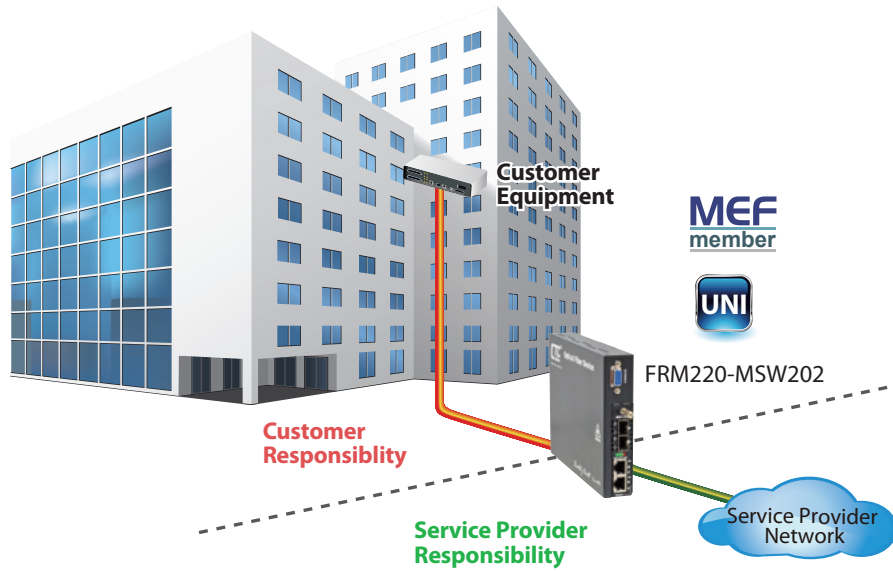

Ordering Information

Model Name	Description
FRM220-MSW202	2x 10/100/1000Base-T + 2x 100/1000Base-X OAM Managed Switch

Note: To Support Console Interface managed, this card must be placed in CH01M chassis.



FRM220-MX210

10/100/1000Base-T + 2x 100/1000/2500Base-X and 100/1000Base-X L2+ Gigabit Carrier Ethernet Switch (EDD)

FRM220-MX210 is a carrier class Ethernet Demarcation Device (EDD) with 10/100/1000Base-T Ethernet ports + 2x 100/1000/2500Base-X and 100/1000Base-X SFP fiber ports which enables EPL (Ethernet Private Line) & EVPL (Ethernet Virtual Private Line) services with advanced carrier Ethernet features per the Metro Ethernet Forum (MEF 9 and 14). By supporting link and service Ethernet OAM schemes, the FRM220-MX210 also provides extensive fault detection and diagnostic capabilities to ensure that actual network use complies with pre-agreed service level agreements (SLAs).

Feature

- Complies with MEF CE1.0
- Supports 8K MAC
- Spanning Tree 802.1D, 802.1s, 802.1w
- Supports 802.1Q / 256 active VLANs
- Double VLAN Tagging (C-tag/S-tag) (IEEE 802.1ad) support for ISP application
- Various QoS capability (MAC/port/802.1p/Diffserv)
- Port-based rate limiting
- DHCP Snooping
- IGMP Snooping
- IPv6 support
- IEEE 802.3x and IEEE 802.1x support
- Jumbo frame for up to 9.6K
- Extensive Ethernet OAM support
- IEEE 802.3ah, IEEE 802.1ag, ITU-T Y.1731
- SNMP v1/v2c/v3, Telnet, Web GUI
- IEEE 1588 V2 aware (Optional)

Specifications

Optical Interface	Port1/Port2	100Base-FX, 1000Base-X or 2500Base-X SFP-LC	Qos Feature	IEEE802.1p priority tag remarking, DSCP remarking, Port based ingress/egress rate limit
	Port3	1000Base-FX or 1000Base-X SFP-LC		
Electrical Interface	Port4	10/100/1000Base-T RJ45 MDI/MDIX auto crossover IEEE802.3x flow control	L2 switching Protection	STP, RSTP, MSTP, ITU-T G8031/G.8032
		(Supports manual 10,100,1000Base-T, Full, Half duplex, or n-way (Auto-Negotiation) each channel)	Trunking	IEEE 802.3ad LACP
Standards		IEEE 802.3 10Base-T, IEEE 802.3u, 100Base-TX, 100Base-FX, IEEE 802.3z 1000Base-X, IEEE 802.3ab, 1000Base-T	Power	12VDC
LEDs		PWR, Link (Port1, Port2, Port3) Port4: Link/Speed	Power Consumption	< 12W
VLAN Feature		IEEE 802.1Q tagged VLAN, port based VLAN, MAC based VLAN, protocol based VLAN, private VLAN, IEEE 802.1ad Q-in-Q	Dimensions	Card: 155 x 20.8 x 88mm (D x W x H)
Qos Feature		IEEE 802.1p 8 priority queues per port, Cos based on switch port; VLAN ID; TCP/UDP port.	Weight	120g
			Temperature	0 ~ 50°C (Operating), -10 ~ 70°C (Storage)
			Humidity	20 ~ 80% non-condensing (Operating); 10 ~ 90% (Storage)
			Certification	CE, FCC
			MTBF	65,000 hrs

Application

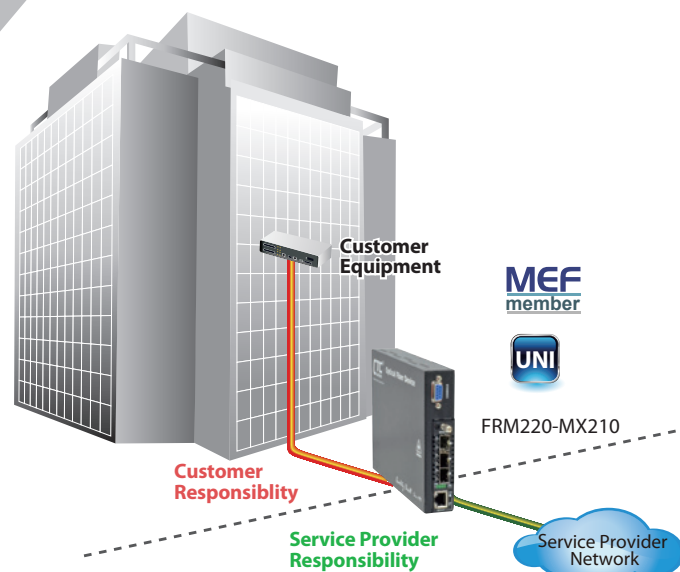

Ordering Information

Model Name	Description
FRM220-MX210	10/100/1000Base-T + 2x 100/1000/2500Base-X + 100/1000Base-X OAM Managed Switch

Note: To Support Console Interface managed, this card must be placed in CH01M chassis.



FRM220A-1002ES

2x 10/100/1000Base-T +
2x 100/1000Base-X SFP GbE Switch

The FRM220A-1002ES is a dual copper and dual fiber Gigabit Ethernet switch designed to make conversion between 10/100/1000Base-T and 100/1000Base-SX/LX with SFP connector. With SNMP and Web-based management in the FRM220 or FRM220A chassis the network administrator can monitor, configure and control the activity of each FRM220A-1002ES switch card locally via the chassis management. Based on a powerful L2 switch architecture, this converter supports bandwidth control, duplex and speed configuration, VLAN tagging, Q-in-Q, QoS, jumbo frames as well as auto laser shutdown, and link fault pass through. When placed stand-alone, this card may only be managed via local serial console when placed in a CH01M single slot type chassis.

Feature

- 2-Port 10/100/1000Base-T and 2-Port 100/1000Base-X Switch
- Auto-Cross over for MDI/MDIX in TP port
- Auto-Negotiation or manual mode in TP port
- Supports flow control Enable or Disable
- Supports Jumbo Frame 10K Bytes
- Supports 16 Tag VLAN Group
- Supports Double VLAN tag (Q-in-Q)
- Supports Bandwidth control
- Supports Loop Back Test
- Supports Link Fault Pass-Through (LFPT) Function
- Supports Auto Laser Shutdown (ALS) Function
- Supports local management on FRM220A rack management.
- Console management on stand-alone.
- Supports D/D function for SFP fiber transceiver
- Provide Product information for management
- Supports the local management (Monitor or Configure status) by the SNMP manager.
- Supports FRM220A for Ethernet Aggregation

Specifications

Optical Interface	Connector	SFP LC	Certification	FCC Part 15 Class A, CE Mark		
	Data rate	125Mbps, 1250Mbps		Electrical Interface	Connector	RJ45
	Duplex mode	Full duplex			Data rate	10Mbps, 100Mbps, 1000Mbps
	Fiber	MM 50/125µm, 62.5/125µm SM 9/125µm		Cable	10Base-T Cat.3, 4, 5, UTP 100Base-TX Cat.5, 5e or higher 1000Base-X Cat.5e or higher	
	Distance	MM 2km, SM 15/30/50/80/120km WDM 20/40/60/80km		Power	12VDC	
Wavelength	MM 1310nm, SM 1310,1550nm WDM 1310Tx/1550Rx (type A) 1550Tx/1310Rx (type B)	Power Consumption	< 12W			
Standards	IEEE 802.3, IEEE 802.3u, 802.3z, 802.3ab, 802.1Q, 802.3X, 802.1ad		Dimensions	Card: 155 x 20.8 x 88mm (DxWxH)		
Indications	PWR, LNK1, LNK2, TEST, LAN Link, LAN SPEED		Weight	130g		
			Temperature	0~50°C (Operating), -10~70°C (Storage)		
			Humidity	0 ~ 95% non-condensing		

Application

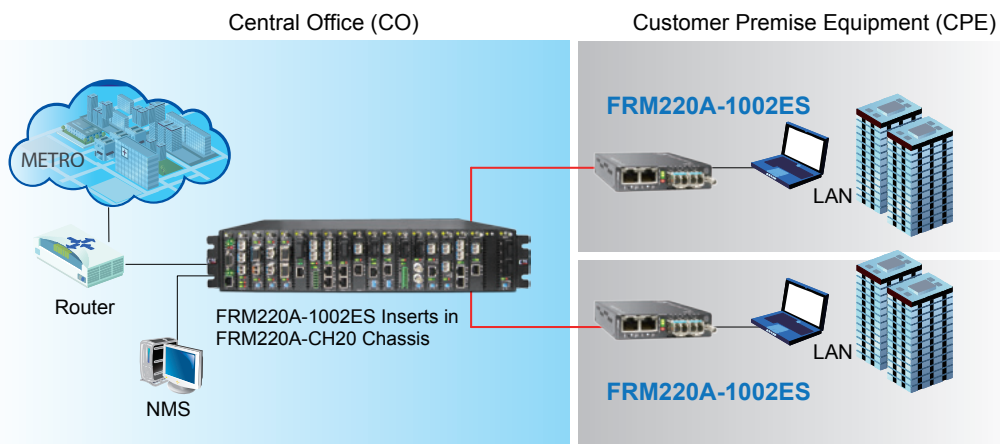

Ordering Information

Model Name	Description
FRM220A-1002ES	2-Port 10/100/1000Base-T and 2-Port 100/1000Base-SX/LX SFP GE Manage Switch (Optional SFP)

Note: Note: This card must use CH01M with serial console, to configure standalone settings.



FRM220A-1000EAS/X

2x 10/100/1000Base-T and
2x 100/1000Base-X SFP OAM/IP GbE
Managed Switch

The FRM220A-1000EAS/X is an IEEE 802.3ah OAM compliant dual copper and dual fiber Gigabit Ethernet switch solution designed to make conversion between 10/100/1000Base-T(X) and 100/1000Base-X with SFP. With embedded SNMP and Web-based management, the network administrator can monitor, configure and control the activity of each IEEE 802.3ah series card and remotely connected OAM compliant converter. Based on a powerful L2 switch architecture, this converter supports bandwidth control, duplex and speed configuration, VLAN tagging, Q-in-Q, QoS, Spanning tree, jumbo frames as well as auto laser shutdown, link fault pass through, OAM loop back and dying gasp. This card may also be controlled and monitored via an NMC in a managed chassis.

Feature

- 2-port 10/100/1000Base-T and 2-port 100/1000Base-X SFP
- Supports local / remote IEEE 802.3ah OAM / IP In-band management
- Standalone IP Based, Web GUI, Telnet, SNMP management
- Auto-Negotiation or forced mode
- Auto MDI/MDIX
- Supports IEEE 802.1Q Tagged and Port based VLAN
- Supports IEEE 802.1ad Q in Q double tagging
- Forward 10K bytes Jumbo packets (max.)
- Supports Flow control (Pause)
- Supports OAM remote loopback to assist in diagnosing network problems
- RADIUS Client
- Supports bandwidth control
- Supports remote CPE power fail detect (dying gasp)
- Supports Far End Fault Indication (FEFI)
- Supports Link Fault Pass-Through (LFPT)
- Supports RMON counter
- D/D function for supported SFP fiber transceiver
- Auto Laser Shutdown (ALS)
- Online local / remote f/w upgrade
- Fiber Redundant mode
- Spanning Tree Protocol
- Port Trunking
- Default port and 802.1p tag priority QoS
- Fixed or weighted priority QoS

Specifications

Optical Interface	Connector	SFP LC
	Data rate	125/1250Mbps
	Duplex mode	Full duplex
	Fiber	MM 50/125µm, 62.5/125µm. SM 9/125µm
	Distance	MM 550m, 2km, SM 15/30/50/80/120km WDM 20/40/60km
Wavelength	MM	1310nm, SM 1310,1550nm
	WDM	1310Tx/1550Rx (type A)
		1550Tx/1310Rx (type B)
Power Consumption	< 12W	
Dimensions	Card: 155 x 20.8 x 88mm (DxWxH)	
Weight	130g	

Electrical Interface	Connector	RJ45	
	Data rate	10Mbps, 100Mbps, 1000Mbps	
	Duplex mode	Half / Full duplex	
	Cable	10Base-T	Cat.3, 4, 5, UTP
		100Base-TX	Cat.5, 5e or higher
	1000Base-T	Cat.5, 5e or higher	
Standards	IEEE 802.3, IEEE 802.3u, IEEE802.1Q, IEEE 802.3ah		
Indications	LED (Power, FX-Link, Test, TX-Link, TX-SPD)		
Power Input	12VDC		
Temperature	0 ~ 50°C (Operating), -10 ~ 70°C (Storage)		
Humidity	10 ~ 90% non-condensing		
Certification	CE, FCC		
MTBF	65,000 hrs		

Ordering Information

Model Name	Description
FRM220A-1000EAS/X	2-Port 10/100/1000Base-T and 2-Port 100/1000Base-X with OAM/IP management, (optional SFP)

Note: This card may use CH01M to provide console for initial TCP/IP settings, or use CH01 with default IP.

OAM/IP GbE Management Switch

FRM220A-1000EAS/X Application

In the Centrally managed application, the main chassis, all of its cards and all fiber connected remote CPE units can be provisioned and monitored from a single management point

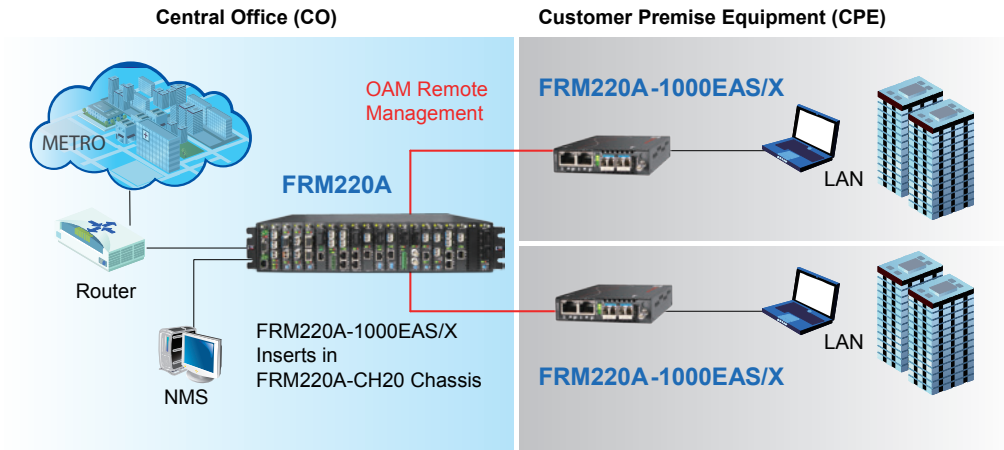

Fiber Redundant / Trunking Application

Utilizing a special trunking function, the 1000EAS/X can be deployed in stand-alone, point-to-point applications and provide 1+1 redundant fiber protection

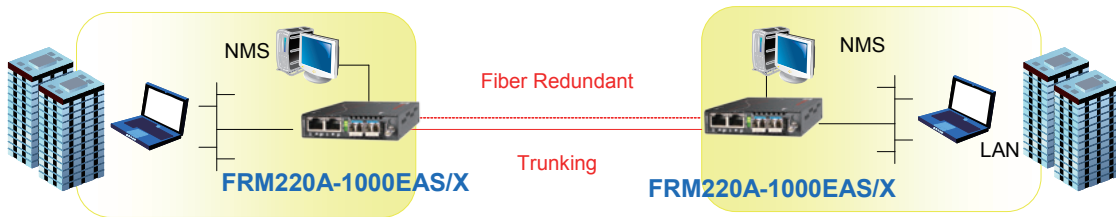

Fiber Ring Application

In the ring or mesh topology, Spanning Tree Protocol enables a highly resilient network based on multiple 1000EAS/X units

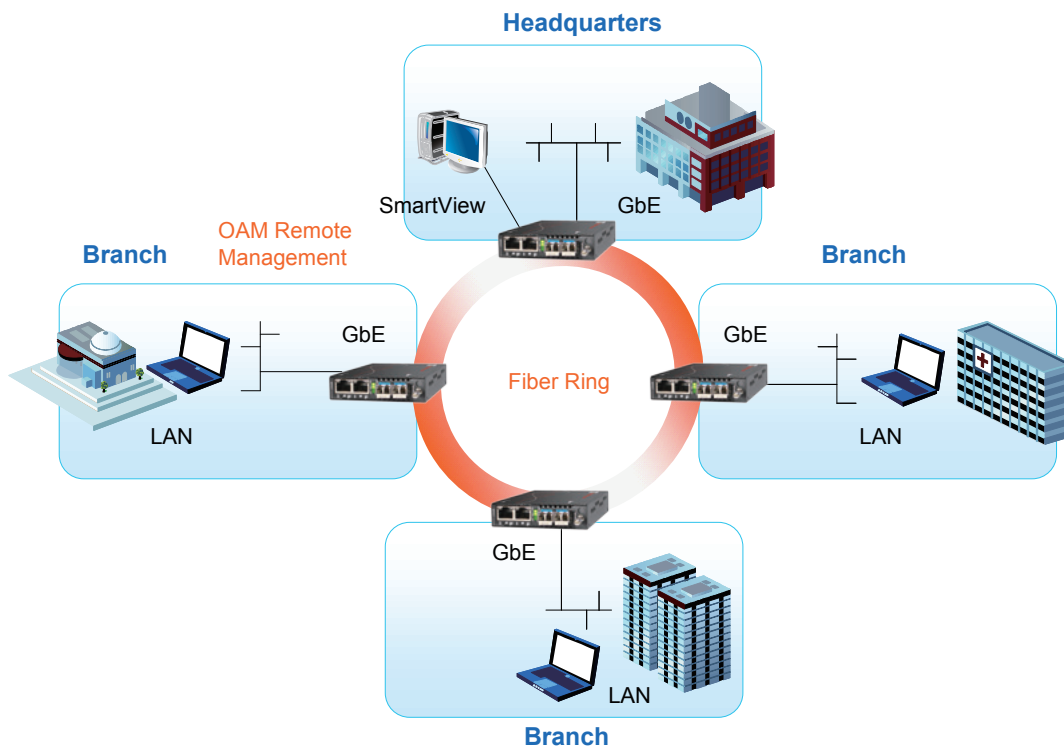



FRM220-10/100

10/100Base-TX to 100Base-FX Unmanaged Media Converter

FRM220-10/100 is a Fast Ethernet 10/100Base-TX to 100Base-FX non-managed stand-alone media converter, which gives the options to choose from the most popular fiber cabling connectors, ST, SC or FC. Both multi-mode and single mode converter models are available as well as BiDi which allows bi-directional transmissions using only a single fiber core. When auto-negotiation is selected, these units will automatically tailor themselves to convert both half-duplex and full-duplex signals, according to IEEE802.3u standards. LED indicators signal the power status of the converter, UTP port speed, Link, and duplex status, FX port Link and duplex status. These non-managed stand-alone converters may also be concentrated into either the FRM220-CH20 or FRM220-CH08 managed chassis.

Feature

- 10/100Base-TX to 100Base-FX Converter
- Auto-Negotiation or forced mode
- Auto MDI/MDIX
- Forward 1600 bytes (Max.) packets
- Supports Q in Q double tagged frame transparent
- Supports IEEE 802.1q Tag VLAN pass thru
- Support flow control (Pause)
- Supports Link Fault Pass through (LFP)
- Forward 9K jumbo packets in converter mode

Specifications

Optical Interface	Connector	1x9 (SC, ST, FC)
	Data rate	100Mbps
	Duplex mode	Full duplex
	Fiber	MM 50/125µm, 62.5/125µm SM 9/125µm
	Distance	MM 2km, SM 15/30/50/80/120km WDM 20/40/60/80km
	Wavelength	MM 1310nm, SM 1310,1550nm WDM 1310Tx/1550Rx (type A) 1550Tx/1310Rx (type B)
Standards	IEEE 802.3, IEEE 802.3u	
Indications	LED (Power, FX Link, TX SPD, TX Link, TX Duplex, FEF)	
Certification	CE, FCC, RoHS	

Electrical Interface	Connector	RJ-45
	Data rate	10Mbps, 100Mbps
	Cable	10Base-T Cat.3, 4, 5, UTP, 100Base-TX Cat.5, 5e or higher
Power	12VDC	
Power Consumption	< 4W	
Dimensions	Card: 155 x 20.8 x 88mm (D x W x H)	
Weight	120g	
Temperature	0 ~ 60°C (Operating), -10 ~ 70°C (Storage)	
Humidity	10 ~ 90% non-condensing	
MTBF	65,000 hrs	

Application

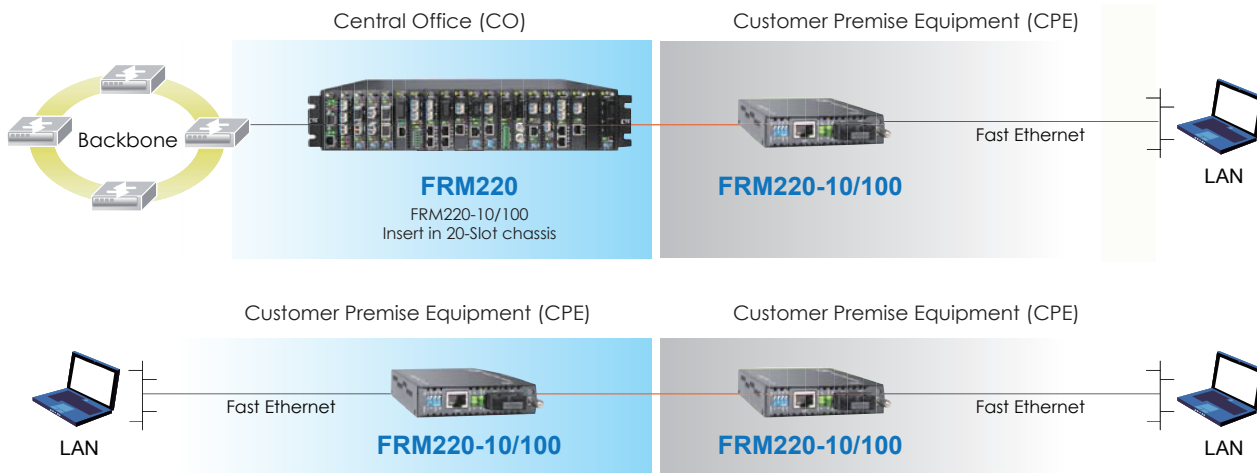

Ordering Information

Model Name	Description
FRM220-10/100	10/100Base-TX to 100Base-FX unmanaged media converter
Connector Type	Connectivity Distance
SC,ST,FC	002: 2km 015: 15km 030: 30km 050: 50km 080: 80km 120: 120km
	20A: WDM 20km A type 20B: WDM 20km B type 40A: WDM 40km A type 40B: WDM 40km B type
	60A: WDM 60km A type 60B: WDM 60km B type 80A: WDM 80km A type 80B: WDM 80km B type

Connector Type Connectivity Distance

FRM220 - 10/100 -

Example: FRM220 - 10/100 - SC002



FRM220-1000DS

1000Base-X to 1000Base-X Media Converter

The FRM220-1000DS is a fiber to fiber optical media converter and repeater that allows data rates up to 1Gbps. FRM220-1000DS supports 2R regeneration, which consists of re-amplification and reshaping. This converter is compatible with fiber interfaces such as 100Mbps Fast Ethernet and 1000Mbps Gigabit Ethernet, STM-1, Fiber Channel 1 and OC3, The FRM220-1000DS works as an FRM220 slide-in card, while the FRM220-1000DS plus FRM220-CH01 work as a stand-alone fiber converter. When the FRM220-1000DS card is placed in the FRM220-CH20 rack with SNMP management, the management can view the converter card's status, type, fiber link status and SFP DOM.

Feature

- Transparent FE or GbE fiber media converter / repeater
- Data rate up to 1G
- Network management via terminal or SNMP in FRM220 chassis
- Extend transmission from 2km to 120km over fiber
- Perform optical repeater function (Re-amplification & Reshaping)
- Digital diagnostic monitoring of SFP modules

Specifications

Optical Interface	Connector	SFP LC x 2
	Data rate	Up to 1G
	Duplex mode	Full duplex
	Fiber	MM 50/125µm, 62.5/125µm. SM 9/125µm
	Distance	MM 550m, 2km, SM 15/30/50/80/120km WDM 20/40/60km
	Wavelength	MM 1310nm, SM 1310,1550nm WDM 1310Tx/1550Rx (type A) 1550Tx/1310Rx (type B)
Indications	LED (Power, FX-Link1, FX-Link2)	
Power Input	12VDC	

Power Consumption	< 6W
Dimensions	Card: 155 x 20.8 x 88 mm (D x W x H)
Weight	130g
Temperature	0 ~ 50°C (Operating), -10 ~ 70°C (Storage)
Humidity	10 ~ 90% non-condensing
Certification	CE, FCC
MTBF	65,000 hrs

Application

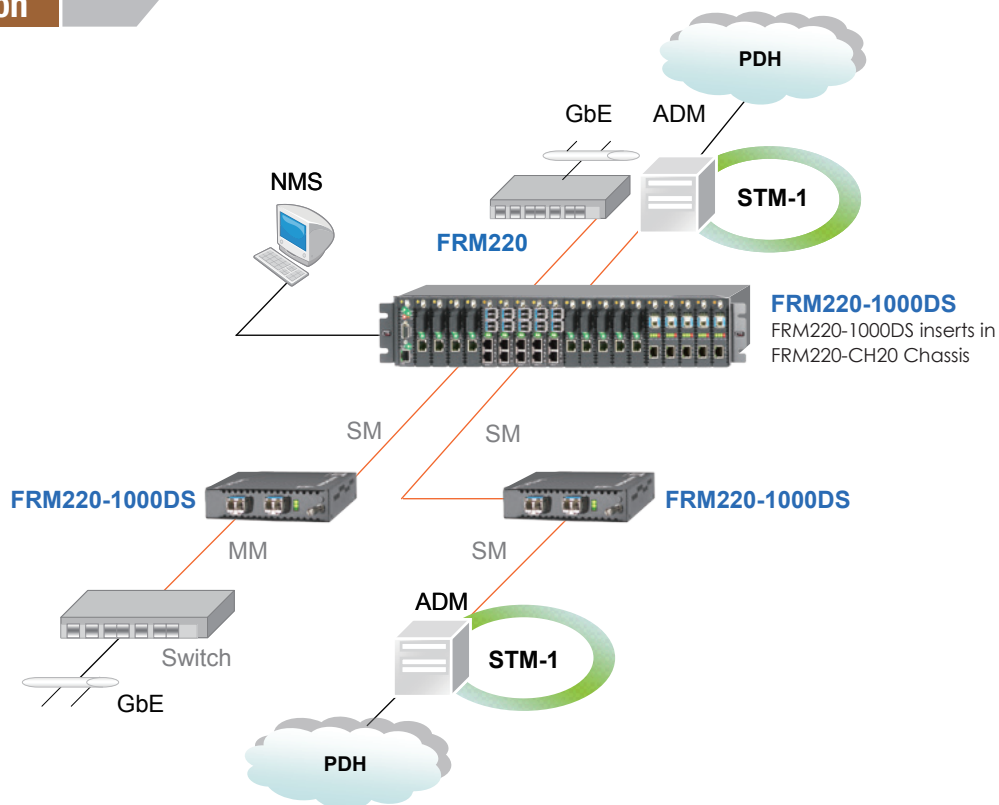

Ordering Information

Model Name	Description
FRM220-1000DS	1000Base-X SFP to 1000Base-X SFP Media Converter (Optional SFP)

Accessories**Multi-Mode 1.25Gbps SFP**

SFM-7000-S85	1.25G SX, MM, 550m, 850nm, 8.5dB, 3.3V, LC
SFM-7000-S85-DD	1.25G SX, MM, 550m, 850nm, 8.5dB, 3.3V, LC, DD
SFM-7000-L31	1.25G LX, MM, 2km, 1310nm, 10dB, 3.3V, LC
SFM-7000-L31-DD	1.25G LX, MM, 2km, 1310nm, 10dB, 3.3V, LC, DD

Single-Mode 1.25Gbps SFP

SFS-7020-L31	1.25G LX, SM, 20km, 1310nm, 15dB, 3.3V, LC
SFS-7020-L31-DD	1.25G LX, SM, 20km, 1310nm, 15dB, 3.3V, LC, DD
SFS-7040-L31	1.25G LX, SM, 40km, 1310nm, 20dB, 3.3V, LC, DFB LD
SFS-7040-L31-DD	1.25G LX, SM, 40km, 1310nm, 20dB, 3.3V, LC, DFB LD, DD

Single Fiber 1.25Gbps SFP

SFS-7020-WA	1.25G WDM, 20km, Tx1310nm / Rx1550nm (A type), 3.3V, LC
SFS-7020-WA-DD	1.25G WDM, 20km, Tx1310nm / Rx1550nm (A type), 3.3V, LC, DD
SFS-7020-WB	1.25G WDM, 20km, Tx1550nm / Rx1310nm (B type), 3.3V, LC
SFS-7020-WB-DD	1.25G WDM, 20km, Tx1550nm / Rx1310nm (B type), 3.3V, LC, DD
SFS-7040-WA	1.25G WDM, 40km, Tx1310nm / Rx1550nm (A type), 3.3V, LC
SFS-7040-WA-DD	1.25G WDM, 40km, Tx1310nm / Rx1550nm (A type), 3.3V, LC, DD
SFS-7040-WB	1.25G WDM, 40km, Tx1550nm / Rx1310nm (B type), 3.3V, LC
SFS-7040-WB-DD	1.25G WDM, 40km, Tx1550nm / Rx1310nm (B type), 3.3V, LC, DD



FRM220-1000TS

1000Base-T to 1000Base-X SFP Media Converter

The FRM220-1000TS is a transparent Gigabit Ethernet 1000Base-T to 1000Base-SX/LX SFP converter with very low latency. They are managed (when installed in FRM220 with NMC) or non-managed stand-alone media converters, which give you the options to choose from a wide range of industry standard SFP modules with LC connectors. SFPs in multi-mode and single mode types are available as well as BiDi which allows bi-directional transmissions using only a single fiber cable. Because they are completely transparent to Ethernet packets, they are able to support any size frames, including undersized or jumbo packets (>9K bytes). LED indicators signal the power status of the converter, UTP port speed, Link, and duplex status, FX port Link and duplex status.

Feature

- 1000Base-T to 1000Base-SX/LX
- Network management via terminal or SNMP in FRM220 chassis
- Auto-negotiation or force mode
- Auto MDI/MDIX
- Forward > 9K bytes packets
- Supports Link Fault Pass Through (LFP) function
- Auto Laser Shutdown (ALS)
- Protocol Transparent

Specifications

Optical Interface	Connector	SFP LC
	Data rate	1000Mbps
	Duplex mode	Full duplex
	Fiber	MM 50/125µm, 62.5/125µm SM 9/125µm
	Distance	MM 550m, 2km, SM15/30/50/80/120km WDM 20/40/60km
	Wavelength	MM 1310nm, SM 1310,1550nm WDM 1310Tx/1550Rx (type A) 1550Tx/1310Rx (type B)
Electrical Interface	Connector	RJ45
	Data rate	1000Mbps
	Duplex mode	Full duplex
	Cable	10Base-T Cat.3, 4, 5, UTP

Standard	IEEE 802.3ab
Indications	LED (Power, FX-Link, FX Duplex, TX-SPD, TX-Duplex, TX-Link)
Power Input	Card : 12VDC Standalone : AC, DC options
Power Consumption	< 12W
Dimensions	Card: 155 x 20.8 x 88mm (D x W x H)
Weight	120g
Temperature	0 ~ 50°C (Operating), -10 ~ 70°C (Storage)
Humidity	10 ~ 90% non-condensing
Certification	CE, FCC, LVD
MTBF	65,000 hrs (25°C)

Application

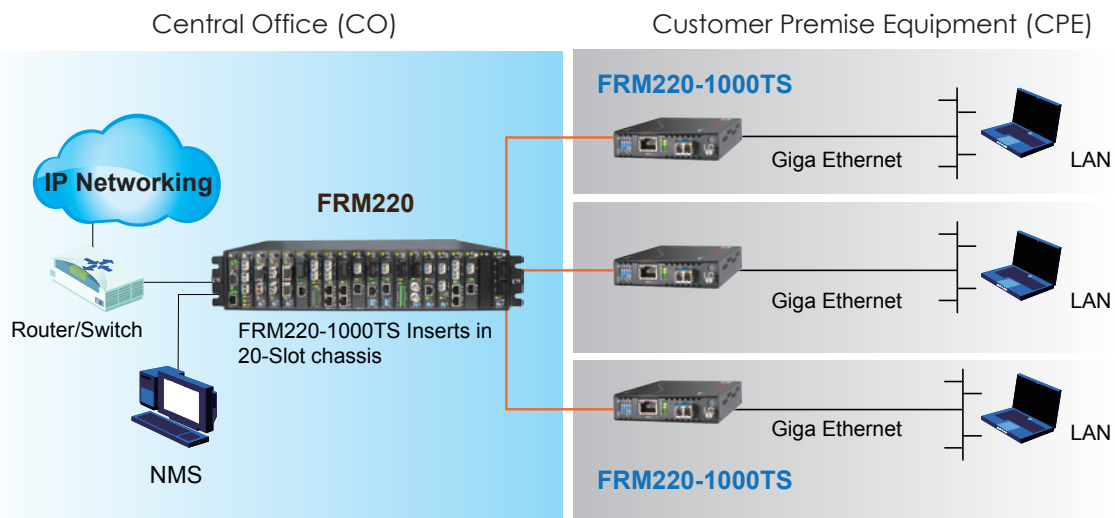

Ordering Information

Model Name	Description
FRM220-1000TS	1000Base-T to 1000Base-X SFP media converter (Optional SFP)



FRM220-1000M

Web Smart OAM Managed 10/100/1000Base-T to 1000Base-X GbE Media Converter

The FRM220-1000M is an IEEE802.3ah OAM compliant copper to fiber Gigabit Ethernet solution designed to make conversion between 10/100/1000Base-T and 100M/1000Base-X with SC, FC or ST connectors. With SNMP and Web-based management in the FRM220, the network administrator can monitor, configure and control the activity of each 802.3ah series card and remotely connected OAM compliant converter. Converter settings include band-width control, duplex, and speed configuration, VLAN tagging and limited Q-in-Q support. When used as stand-alone converters, the 1000M can be managed by a friendly WebSmart user interface via any web browser.

Feature

- 10/100/1000Base-T to 1000Base-X Converter
- Auto-Cross over for MDI/MDIX in TP port
- Auto-Negotiation or manual mode in TP port
- Supports flow control Enable or Disable
- Supports Jumbo Frame 9K Bite
- Ingress / Egress bandwidth control
- Supports IEEE 802.3ah OAM in-band management
- Firmware upgrade via Web
- Management Password Security
- Dying gasp (remote power failure detection)
- Supports Link Fault Pass-Through (LFPT) Function
- Supports Auto Laser Shutdown (ALS) Function
- Allow IP settings Web or Console management on stand-alone.
- Provide Product information for management
- Online local/remote f/w upgrade
- Supports 16 Tag VLAN Group
- RMON counters (for standalone unit only)

Specifications

Optical Interface	Connector	1x9 (SC)
	Data rate	125/1250Mbps
	Duplex mode	Full duplex
	Fiber	MM 50/125µm, 62.5/125µm SM 9/125µm
	Distance	MM 2km, SM 15/30/50/80/120km WDM 20/40/60/80km
	Wavelength	MM 1310nm, SM 1310,1550nm WDM 1310Tx/1550Rx (type A) 1550Tx/1310Rx (type B)
Electrical Interface	Connector	RJ45
	Data rate	10Mbps, 100Mbps, 1000Mbps
	Duplex mode	Half / Full duplex
	Cable	10Base-T Cat.3, 4, 5, UTP, 100Base-TX Cat.5, 5e or higher

Standards	IEEE 802.3, IEEE 802.3u IEEE 802.3ab, 802.3z, 802.3ah, 802.1Q
Indications	LED (Power, FX-Link, LAN Speed, LAN Link)
Power Input	12VDC
Power Consumption	< 6W
Dimensions	Card: 155 x 20.8 x 88mm (D x W x H)
Weight	120g
Temperature	0 ~ 50°C (Operating), -10 ~ 70°C (Storage)
Humidity	10 ~ 90% non-condensing
Certification	CE, FCC
MTBF	65,000 hrs

Application

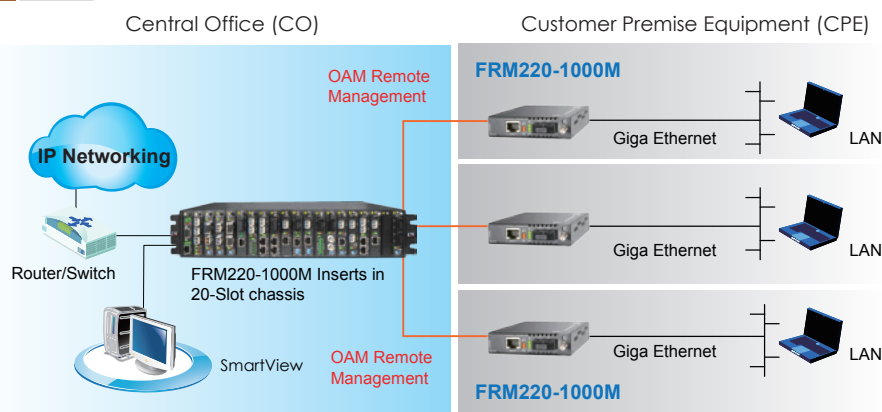

Ordering Information

Model Name	Description
FRM220-1000M	10/100/1000Base-T to 1000Base-X, Web Smart OAM managed media converter
Connector Type	Connectivity Distance
SC	002: 2km 015: 15km 030: 30km 050: 50km 20A: WDM 20km A type 20B: WDM 20km B type 40A: WDM 40km A type 40B: WDM 40km B type

Note: This card may use CH01M to provide console for initial TCP/IP settings, or use CH01 with default IP.



FRM220-1000MS

Web Smart OAM Managed 10/100/1000Base-T to 100/1000Base-X SFP GbE Media Converter

The FRM220-1000MS is an IEEE802.3ah OAM compliant copper to fiber Gigabit Ethernet solution designed to make conversion between 10/100/1000Base-T and 100/1000Base-X with SFP modules. With SNMP and Web-based management in the FRM220, the network administrator can monitor, configure and control the activity of each 802.3ah series card and remotely connected OAM compliant converter. Converter settings include bandwidth control, duplex, and speed configuration, VLAN tagging, limited Q-in-Q support and SFP DDMI. When used as stand-alone converters, the 1000M can be managed by a friendly WebSmart user interface via any web browser.

Feature

- 1-Port 10/100/1000Base-T to 100/1000Base-X Converter
- Auto-Cross over for MDI/MDIX in TP port
- Auto-Negotiation or manual mode in TP port
- Supports flow control Enable or Disable
- Supports Jumbo Frame 9K Packet
- Ingress / Egress bandwidth control
- Supports 802.3ah-OAM in-band management
- Firmware upgrade via Web (for standalone unit only)
- Management Password Setting (for standalone unit only)
- Dying gasp (remote power failure detection on stand-alone)
- Supports Link Fault Pass-Through (LFPT) Function
- Supports Auto Laser Shutdown (ALS) Function
- Allow IP settings web or console management
- Supports D/D function for SFP fiber transceiver
- Supports 16 Tag VLAN Group
- RMON counters (for standalone unit only)

Specifications

Optical Interface	Connector	SFP LC	Standards	IEEE 802.3, 802.3u, 802.3ab, 802.3z, 802.3ah, 802.1Q				
	Data rate	125/1250Mbps		Indications	LED (Power, FX-Link, LAN Speed, LAN Link)			
	Duplex mode	Full duplex			Power Input	12VDC		
	Fiber	MM 50/125µm, 62.5/125µm. SM 9/125µm				Power Consumption	< 6W	
	Distance	MM 2km, SM 15/30/50/80/120km, WDM 20/40/60/80km					Dimensions	Card: 155 x 20.8 x 88mm (D x W x H)
	Wavelength	MM 1310nm, SM 1310,1550nm WDM 1310Tx/1550Rx (type A) 1550Tx/1310Rx (type B)						Weight
Electrical Interface	Connector	RJ45	Temperature					
	Data rate	10Mbps, 100Mbps, 1000Mbps		Humidity				
	Duplex mode	Half / Full duplex			Certification			
	Cable	10Base-T Cat.3, 4, 5, UTP 100Base-TX Cat.5, 5e or higher				MTBF		

Application

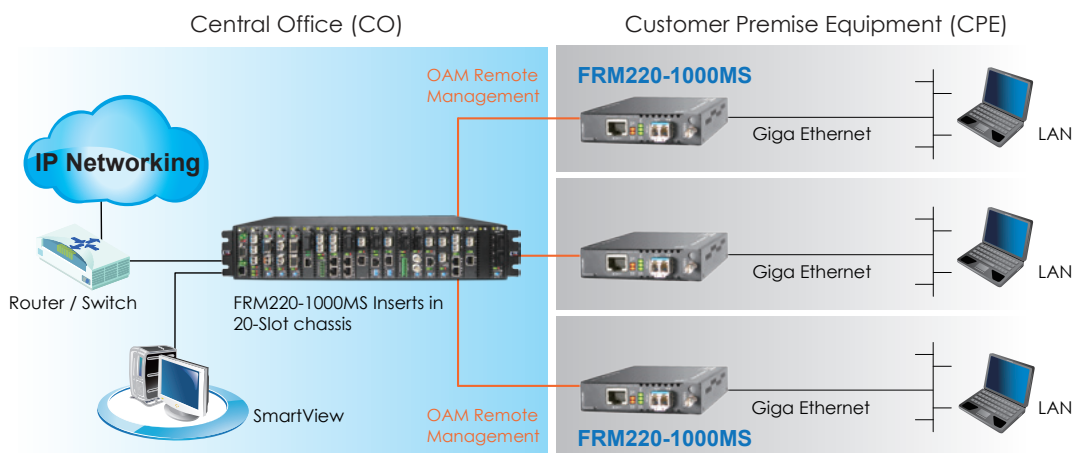

Ordering Information

Model Name	Description
FRM220-1000MS	10/100/1000Base-T to 100/1000Base-X SFP Web smart OAM managed media converter. (Optional SFP)

Note: This card may use CH01M to provide console for initial TCP/IP settings, or use CH01 with default IP.



FRM220-1000EAS/X-1

OAM/IP Managed 10/100/1000Base-T to 100/1000Base-X SFP GbE Media Converter

The FRM220-1000EAS/X-1 is an IEEE802.3ah OAM compliant copper to fiber Gigabit Ethernet solution designed to make conversion between 10/100/1000Base-T and 100/1000Base-X with SFP. With stand-alone SNMP and Web-based management, the network administrator can monitor, configure and control the activity of each IEEE802.3ah series card and remotely connected OAM compliant converter. By offering IEEE802.3ah OAM in-band management, this converter can also be completely controlled and monitored from a centrally located managed rack. Based on a powerful L2 switch architecture, this converter supports bandwidth control, duplex and speed configuration, VLAN tagging, Q-in-Q, QoS, Spanning tree as well as auto laser shutdown, link fault pass through, OAM loop back and dying gasp.

Feature

- 10/100/1000Base-T to 100/1000Base-X SFP
- Supports local / remote IEEE802.3ah OAM/ IP In-band management
- Stand-alone IP Based, Web GUI, Telnet, SNMP management
- Auto-Negotiation or forced mode
- Auto MDI/MDIX
- Supports IEEE 802.1Q Tagging
- Supports Q in Q double tagging
- Forward 10K bytes Jumbo packets (max.)
- Supports Flow control (Pause)
- Supports OAM remote loopback to assist in diagnosing network problems
- Supports remote IP ping function for diagnostic purpose
- Supports bandwidth control
- Supports remote CPE power fail detect (dying gasp)
- Supports Far End Fault Indication (FEFI)
- Supports Link Fault Pass-Through (LFPT)
- Supports RMON counter
- D/D function for supported SFP fiber transceiver
- Auto Laser Shutdown (ALS)
- Online local / remote f/w upgrade
- Default port and IEEE802.1Q Tagging priority QoS

Specifications

Optical Interface	Connector	SFP LC
	Data rate	100/1000Mbps
	Duplex mode	Full duplex
	Fiber	MM 50/125µm, 62.5/125µm. SM 9/125µm
	Distance	MM 550m, 2km, SM 15/30/50/80/120km WDM 20/40/60km
	Wavelength	MM 1310nm, SM 1310, 1550nm WDM 1310Tx/1550Rx (type A) 1550Tx/1310Rx (type B)
Power Consumption	< 8W	
Dimensions	Card: 155 x 20.8 x 88mm (D x W x H)	
Weight	120g	

Electrical Interface	Connector	RJ45
	Data rate	10Mbps, 100Mbps, 1000Mbps
	Duplex mode	Half / Full duplex
	Cable	10Base-T Cat.3, 4, 5, UTP 100Base-TX Cat.5, 5e or higher 1000Base-T Cat.5, 5e or higher
Standards	IEEE 802.3, IEEE 802.3u, IEEE 802.1Q, IEEE 802.3ab, IEEE 802.3z	
Indications	LED : Power, FX-Link, FEF, TEST, Speed(10,100,1000), FULL	
Power Input	Card : 12VDC Standalone : AC, DC options	
Temperature	0 ~ 50°C (Operating), -10 ~ 70°C (Storage)	
Humidity	10 ~ 90% non-condensing	
Certification	CE, FCC	
MTBF	65,000 hrs	

Application

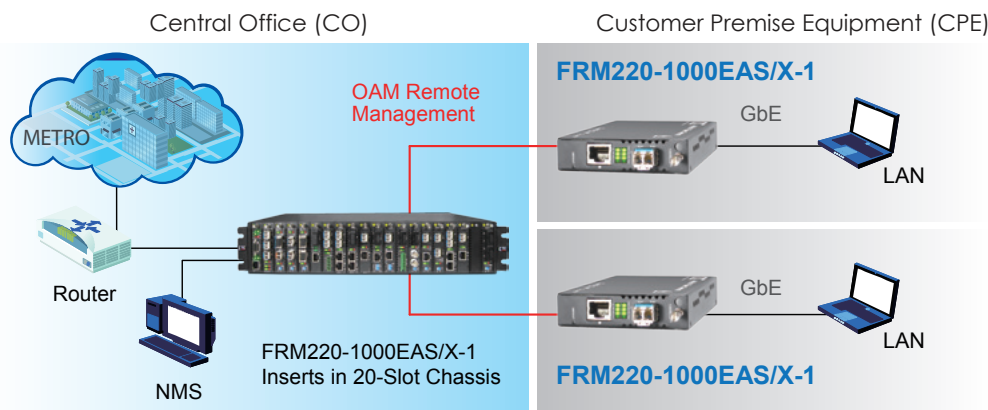

Ordering Information

Model Name	Description
FRM220-1000EAS/X-1	10/100/1000Base-T to 100/1000Base-X with OAM/IP-Based managed GbE Media Converter, (optional SFP)

Note: This card may use CH01M to provide console for initial TCP/IP settings, or use CH01 with default IP.



FRM220-100EAS/X-1

(Order Name - **FRM220-100AS-1**)

OAM/IP Managed 10/100Base-TX to 100Base-FX FE Media Converter

The FRM220-100AS-1 is an IEEE802.3ah OAM compliant copper to fiber Fast Ethernet solution designed to make conversion between 10/100Base-TX and 100Base-FX with SFP. With stand-alone SNMP and Web-based management, the network administrator can monitor, configure and control the activity of each IEEE802.3ah series card and remotely connected OAM compliant converter. By offering IEEE802.3ah OAM in-band management, this converter can also be completely controlled and monitored from a centrally located managed rack. Based on a powerful L2 switch architecture, this converter supports bandwidth control, duplex and speed configuration, VLAN tagging, Q-in-Q, QoS, Spanning tree as well as auto laser shutdown, link fault pass through, OAM loop back and dying gasp.

Feature

- 10/100Base-TX to 100Base-FX SFP
- Supports local / remote IEEE802.3ah OAM/ IP In-band management
- Stand-alone IP Based, Web GUI, Telnet, SNMP management
- Auto-Negotiation or forced mode
- Auto MDI/MDIX
- Supports IEEE 802.1Q Tagging
- Supports Q in Q double tagging
- Max. MTU size 10K bytes
- Supports Flow control (Pause)
- Supports OAM remote loopback to assist in diagnosing network problems
- Supports bandwidth control
- Supports remote CPE power fail detect (dying gasp)
- Supports Far End Fault Indication (FEFI)
- Supports Link Fault Pass-Through (LFPT)
- Supports remote loopback
- D/D function for supported SFP fiber transceiver
- Auto Laser Shutdown (ALS)
- Online local / remote f/w upgrade
- Default port and IEEE802.1Q Tagging priority QoS
- SNMP trap and LED alarm for loss of light and loss of signal

Specifications

Optical Interface	Connector	SFP LC
	Data rate	100Mbps
	Duplex mode	Full duplex
	Fiber	MM 50/125µm, 62.5/125µm. SM 9/125µm
	Distance	MM 550m, 2km, SM15/30/50/80/120km WDM 20/40/60km
Wavelength	MM	1310nm, SM 1310, 1550nm
	WDM	1310Tx/1550Rx (type A) 1550Tx/1310Rx (type B)
Power Consumption	< 12W	
Dimensions	Card: 155 x 20.8 x 88mm (D x W x H)	
Weight	120g	
Electrical Interface	Connector	RJ45
	Data rate	10Mbps, 100Mbps
	Duplex mode	Half / Full duplex

Electrical Interface	Cable: 10Base-T	Cat.3, 4, 5, UTP
	100Base-TX	Cat.5, 5e or higher
Standards	IEEE 802.3, IEEE 802.3u, IEEE 802.1Q, ITU-T G.664	
Indications	LED : Power, FX-Link, FEF, TEST, Speed(10,100), FULL	
Power Input	Card	: 12VDC
	Standalone	: AC, DC options
Temperature	Storage conditions	
	Temperature range : -5~+45°C	
	Relative Humidity : 5~95% Rh	
	Absolute Humidity : 1~25g H2O/m ³	
	Operation conditions	
Temperature range : -5~+45°C		
Relative Humidity : 5~95% Rh		
Exist conditions for condensation and icing		
Absolute Humidity : 1~29g H2O/m ³		
Certification	CE, FCC, EN60950 LVD compliant	
MTBF	65,000 hrs	

Application

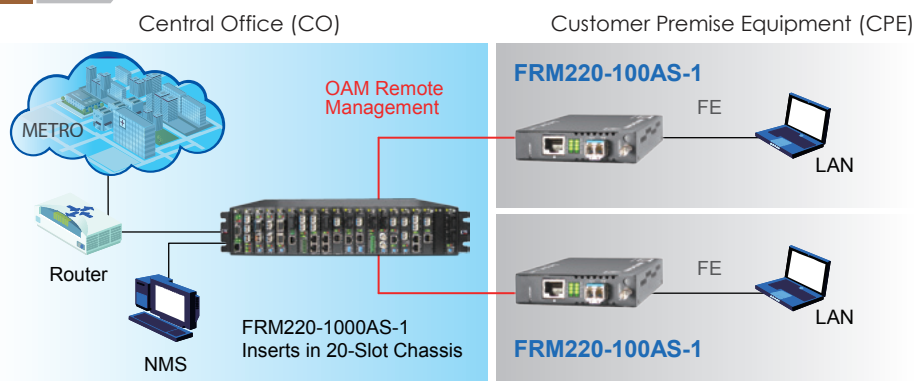

Ordering Information

Model Name	Description
FRM220-100AS-1	10/100Base-TX to 100Base-FX with OAM/IP-Based managed FE Media Converter (optional SFP)

Note: This card may use CH01M to provide console for initial TCP/IP settings, or use CH01 with default IP.



FRM220-10/100i

In-Band Management 10/100Base-TX to 100Base-FX Media Converter

The FRM220-10/100i is a 10/100Base Ethernet to 100Base-FX fiber slide-in card converter designed for central and remote applications. With advanced features like bandwidth control, this media converter is targeted for customer premises equipment in metro LAN, campus, enterprise and FTTx applications. By offering in-band management, this converter can be completely controlled and monitored from a centrally located managed rack controlling all converter settings including bandwidth control, duplex, and speed configuration. This media converter is completely transparent to Layer 2 and Layer 3 protocols including IEEE 802.1q, VLAN tag, Q in Q, STP, IPX, IP, etc. When used stand-alone, this converter has no access to management functions except to force Ethernet connection and apply Link Fault Pass-thru via setting of a 4-pole DIP switch.

Feature

- 1-Port 10/100Base-TX to 100Base-FX Converter
- Auto-Negotiation or forced mode
- Supports remote CPE power fail detect (dying gasp)
- Supports Far End Fault Indication (FEFI)
- Supports Link Fault Pass-Through (LFPT)
- Supports Loop Back Test
- Supports RMON counter
- Auto Laser Shutdown (ALS)
- Auto MDI/MDIX
- Forward 2046 bytes (max.) packets in switch mode
- Forward 9K jumbo packets in converter mode
- Supports Q in Q double tagged frame transparent
- Supports IEEE 802.1q Tag VLAN pass thru
- Supports local / remote In-band management (Monitor and Configure) by the SNMP manager.
- Bandwidth control (Nx32Kbps or Nx512Kbps)
- Supports IEEE 802.3x flow control (Pause)
- Fiber Hardware Reset (FHR)
- Online local / remote f/w upgrade

Specifications

Optical Interface	Connector	1 x 9 (SC, ST, FC)	Standards	IEEE 802.3, IEEE 802.3u, TS-1000	
	Data rate	125Mbps		Indications	LED (Power, FEF, FX-Link, TX-SPD, TX-Duplex, TX-Link)
	Duplex mode	Full duplex			Power Input
	Fiber	MM 50/125µm, 62.5/125µm SM 9/125µm		Power Consumption	
	Distance	MM 2km, SM 15/30/50km WDM 20/40km			Dimensions
	Wavelength	MM 1310nm, SM 1310, 1550nm WDM 1310Tx/1550Rx (type A) 1550Tx/1310Rx (type B)		Weight	
Electrical Interface	Connector	RJ45	Temperature		0 ~ 50°C (Operating), -10 ~ 70°C (Storage)
	Data rate	10Mbps, 100Mbps		Humidity	10 ~ 90% non-condensing
	Duplex mode	Half / Full duplex	Certification		CE, FCC
	Cable	10Base-T Cat.3, 4, 5, UTP 100Base-TX Cat.5, 5e or higher		MTBF	65,000 hrs

Application

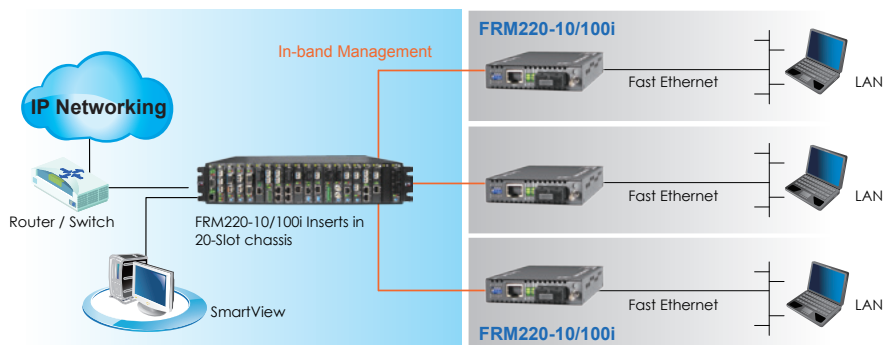

Ordering Information

Model Name	Description
FRM220-10/100i	10/100Base-TX to 100Base-FX In-band managed converter
Connector Type	Connectivity Distance
SC, ST, FC	002: 2km 015: 15km 030: 30km 050: 50km 20A: WDM 20km A type 20B: WDM 20km B type 40A: WDM 40km A type 40B: WDM 40km B type

Connector Type Connectivity Distance
FRM220 – 10/100i – □□□□□
 Example: FRM220 – 10/100i – SC002

Note: This card must use CH01M, with serial console, to configure standalone settings. When connected as a remote to a managed central chassis, this card supports in-band management and only needs a CH01 chassis.



FRM220-10/100iS-2

Dual Channels 10/100Base-TX to 100Base-FX In-Band Managed Converter

The FRM220-10/100iS-2 is a dual (2 in 1) 10/100Base Ethernet to 100Base-FX fiber slide-in card converter based on the popular FRM220-10/100i. With advanced features like bandwidth control, this media converter is targeted for customer premises equipment in metro LAN, campus, enterprise and FTTx applications. By offering in-band management, this converter can be completely controlled and monitored from a centrally located managed rack controlling all converter settings including bandwidth control, duplex, and speed configuration. By offering two completely isolated converters on one card, this card can effectively double the conversion capacity of a rack.

Feature

- Dual independent converters 10/100Base-TX to 100Base-FX
- Auto-Negotiation or forced mode
- Auto MDI/MDIX
- Forward 2046 bytes (max.) packets in switch mode
- Supports IEEE 802.1Q Tag VLAN pass thru
- Supports Q in Q double tagged frame transparent
- Forward 9K jumbo packets in converter mode
- Supports local / remote In-band management (Monitor and Configure) by the SNMP manager
- Bandwidth control (Nx32Kbps or Nx512Kbps) & flow control (Pause)
- Supports remote CPE power fail detect (dying gasp)
- Supports Far End Fault Indication (FEFI) and Link Fault Pass-Through (LFPT)
- Supports Loop Back Test and RMON counter
- D/D function for supported SFP fiber transceiver
- Auto Laser Shutdown (ALS) and Fiber Hardware Reset (FHR)
- Online local / remote f/w upgrade

Specifications

Optical Interface	Connector	SFP LC	Standards	IEEE 802.3, IEEE 802.3u, IEEE 802.3s, TS-1000	
	Data rate	125 Mbps		Indications	LED (Power, FEF, FX-Link, TX-SPD, TX-Duplex, TX-Link)
	Duplex mode	Full duplex			Power Input
	Fiber	MM 50/125µm, 62.5/125µm. SM 9/125µm		Power Consumption	
	Distance	MM 2km, SM 15/30/50/80/120km, WDM 20/40/60/80km			Dimensions
Wavelength	MM 1310nm, SM 1310,1550nm WDM 1310Tx/1550Rx (type A) 1550Tx/1310Rx (type B)	Weight	130g		
Electrical Interface	Connector		RJ-45	Temperature	0 ~ 50°C (Operating), -10 ~ 70°C (Storage)
	Data rate	10Mbps, 100Mbps	Humidity		10 ~ 90% non-condensing
	Duplex mode	Half / Full duplex		Certification	CE, FCC, RoHS compliant
	Cable	10Base-T Cat.3, 4, 5, UTP 100Base-TX Cat.5, 5e or higher	MTBF		65,000 hrs

Application

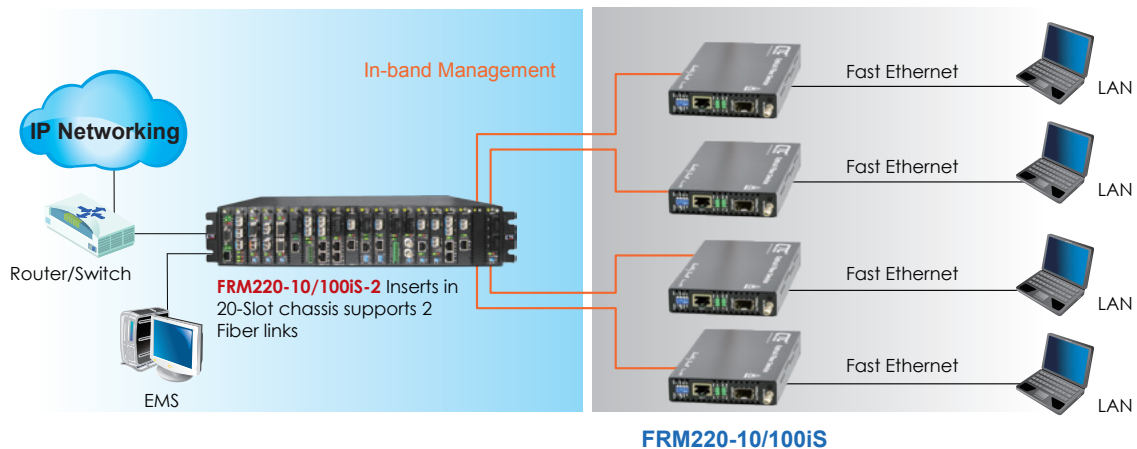

Ordering Information

Model Name	Description
FRM220-10/100iS-2	Dual converter 10/100Base-TX to 100Base-FX SFP with In-band management, (optional SFP)

Note: The Card is suitable use in CH01 standalone chassis.



FRM220-FXO-4

4x FXO over Fiber

FRM220-FXS-4

4x FXS over Fiber

FRM220-FXO/FXS-4 are 4 channel POTS (Plain Old Telephone System) over fiber converter/extender. The four POTS connection uses standard RJ-11C modular connectors for each copper pair connection. A pair of FRM220-FXO/FXS-4 is required to implement an end to end system. FXO type unit connects to a telephone line (PSTN) or PBX station line and has ability to detect ringing voltages and to act as a telephone. FXS type unit is the reciprocal unit and has ability to act as PSTN and connects to a telephone device. Two FXS cards may be connected back-to-back to provide a private "hot line". When the FRM220-FXO/FXS-4 cards are placed in the FRM220 rack with SNMP management, in-band management allows configuring and viewing the card and remote converter's status, type, version, fiber link status, on hook status and alarms. When placed in a single slot chassis and used standalone without management, the card may be configured by DIP switch.

Feature

- Extend telephone voice transmission up to 120km over fiber
- Network management via terminal, web or SNMP in FRM220 chassis
- Supports telephone voice transmission
- Supports caller ID Pass-Through
- Supports FXS to FXS hot line

Specifications

Optical Interface	Connector	SFP-LC
	Fiber	MM 62.2/125µm, 50/125µm, SM 9/125µm
	Rate	155Mbps
	Distance	MM 2km, SM 15/30/50km, WDM 20/40km
Wavelength	MM	1310nm, SM 1310, 1550nm
	WDM	1310Tx/1550Rx (type A) 1550Tx/1310Rx (type B)
Indications	LED (Power, FX Link, Phone Act, Test)	
Power Input	12VDC	
Power Consumption	< 6W (FRM220-FXO-4) < 12W (FRM220-FXS-4)	
Dimensions	Card: 155 x 20.8 x 88mm (D x W x H)	
Weight	120g	
Temperature	0 ~ 50°C (Operating), -10 ~ 70°C (Storage)	
Humidity	10 ~ 90% non-condensing	
Certification	CE, FCC	
MTBF	65,000 hrs	

Electrical Interface	Connector	RJ-11
	FXO mode	Impedance : 600 ohms Coding : 16 bits liner Loop Current : 10~100mA Ring Frequency : Acceptable 20 ~50Hz Insertion Loss: 0.0 ± 1.0dB at 1000Hz Impedance : 600 ohms
	FXS mode	Coding : 16 bits liner Dial: DTMF and Dial Pulse Provides 48VDC ± 4V to FXO Ringing Waveform : Sine wave Ringing Frequency : 20/25/30/35/40/45/50 Hz selectable Ring Cadence: FXS to FXS: On / 1 sec, Off / 2 sec FXO to FXS; Reproduces the cadence detected by FXO Insertion Loss 0.0 ± 1.0dB at 1000Hz REN: 4.0B(Ring Equivalence Number)

Application

Figure 1 : Automatic Ring down hotline

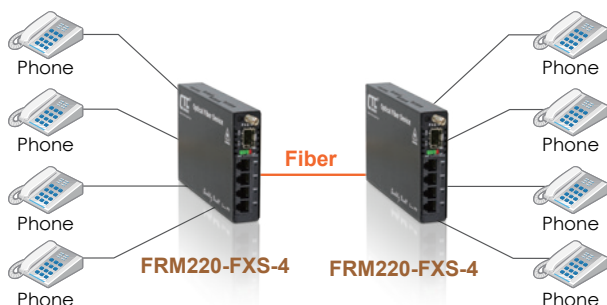
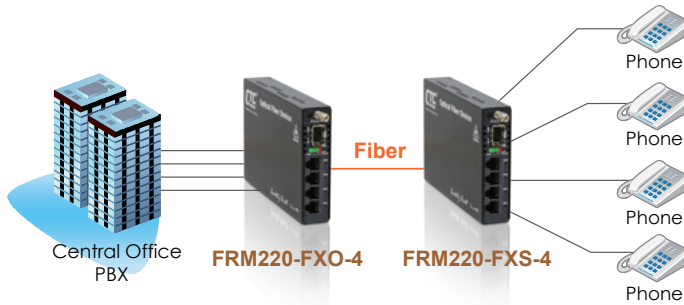

Figure 2 : Voice transmission from 2km to 120km over fiber



Ordering Information

Model Name	Description
FRM220-FXO-4	4-port FXO fiber converter SFP-LC
FRM220-FXS-4	4-port FXS fiber converter SFP-LC

Connector Type Connectivity Distance

FRM220 – FXO-4 – □□□□□□

Example: FRM220 – FXO-4 – SC002

Note: This card may be set by DIP switch and placed in CH01 standalone chassis. When connected as a remote to a managed central chassis, this card supports in-band management.



FRM220-FXO/FXS

FXO/FXS over Fiber

FRM220-FXO/FXS is a POTS (Plain Old Telephone System) over fiber converter/extender. The POTS connection uses a standard RJ-11C modular connector for one copper pair connection. A pair of FRM220-FXO/FXS is required to implement an end to end system. FXO mode connects to a telephone line (PSTN) or PBX station line and has ability to detect ringing voltages and to act as a telephone. FXS mode is the reciprocal unit and has ability to act as PSTN and connects to a telephone device. When the FRM220-FXO/FXS card is placed in the FRM220 rack with SNMP management, in-band management allows configuring and viewing the card and remote converter's status, type, version, fiber link status, on hook status and alarms. Both card and remote can be configured to enable or disable the port, reset the port and set the FXO or FXS mode. When configured in an FXS to FXS fashion, a private "hot line" or direct line is created. When placed in a single slot chassis and used standalone without management, the card may be configured by DIP switch.

Feature

- Extend telephone voice transmission up to 120km over fiber
- Network management via terminal, web or SNMP in FRM220 chassis
- Supports caller ID Pass-Through
- Selectable FXO or FXS mode
- Supports FXS to FXS hot line

Specifications

Optical Interface	Connector	1x9 (SC)
	Fiber	MM 62.2/125μm, 50/125μm, SM 9/125μm Rate: 155Mbps
	Distance	MM 2km, SM 15/30/50km, WDM 20/40km
	Wavelength	MM 1310nm, SM 1310, 1550nm WDM 1310Tx/1550Rx (type A) 1550Tx/1310Rx (type B)
Indications	LED (Power, FX Link, Phone Act, Test)	
Power Input	12VDC	
Power Consumption	< 6W	
Dimensions	Card: 155 x 20.8 x 88mm (D x W x H)	
Weight	120g	
Temperature	0 ~ 50°C (Operating), -10 ~ 70°C (Storage)	
Humidity	10 ~ 90% non-condensing	
Certification	CE, FCC	
MTBF	65,000 hrs	

Electrical Interface	Connector	RJ-11
	FXO mode	Impedance : 600 ohms Coding : 16 bits liner Loop Current : 10~100mA Ring Frequency : Acceptable 20 ~50Hz Insertion Loss: 0.0 ± 1.0dB at 1000Hz Impedance : 600 ohms
	FXS mode	Coding : 16 bits liner Dial: DTMF and Dial Pulse Battery Source: 48VDC ± 4V Ringing Waveform : Sine wave Ringing Frequency : 20/25/30/35/40/45/50 Hz selectable Ring Cadence: FXS to FXS : On / 1 sec, Off / 2 sec FXO to FXS; Reproduces the cadence detected by FXO Insertion Loss 0.0 ± 1.0dB at 1000Hz REN: 4.0B(Ring Equivalence Number)

Application

Figure 1 : Automatic Ring down hotline



Figure 2 : Voice Transmission from 2km to 120km over fiber



Figure 3 : Selectable FXO or FXS mode



Ordering Information

Model Name	Description
FRM220-FXO/FXS	FXO / FXS fiber converter
Connector Type	Connectivity Distance
SC, ST, FC	002: 2km 015: 15km 030: 30km 050: 50km 20A: WDM 20km A type 20B: WDM 20km B type 40A: WDM 40km A type 40B: WDM 40km B type

Note: This card may be set by DIP switch and placed in CH01 standard chassis, When connected as a remote to a managed central chassis, this card supports in-band management.



FRM220A-iMux

Ethernet over Bonded E1 NTU

2

Inverse Mux

The FRM220A-iMux is an E1 inverse multiplexer capable of bundling 4E1/ 8E1/16E1 lines for cost-effective connection of 10/100Base-TX LANs over multiple E1 transports. The FRM220A- iMux transmits 7.93Mbps (iMUX4)/ 15.87Mbps(iMUX8)/ 31.74Mbps(iMUX16) Ethernet bridge channel (GFP-F encapsulated) over multiple E1 links. The FRM220A-iMux bridges the gap between E1 and E3, allowing bridges to operate at faster rates. It also provides high speed access to SDH/SONET backbones where the only access services available are E1 lines. The FRM220A-iMux supports E1 attenuation of up to 43 dB on twisted pair or coax cable. This provides an approximate operating range up to 2km (using 22AWG). The FRM220A-iMUX fully comply the E1 specifications including ITU-T G.703 and G.823. The FRM220A-iMux features diagnostic capabilities for performing remote loopback. The operator at either end of the line may test both FRM220A-iMux NTU and the line in the digital loopback mode. The Ethernet copper interface supports auto-negotiation and auto MDI/MDIX, allowing plug-and-play Ethernet connection without any additional configuration.

Feature

- The FRM220A - iMUX connects one Fast Ethernet over 1-4 E1 links (1.984Mbps to 7.93Mbps) for iMUX4, over 1- 8 E1 links (1.984Mbps to 15.87Mbps) for iMUX8, over 1- 16 E1 links (1.984Mbps to 31.74Mbps) for iMUX16
- Built-in GFP bridge operates at WAN rate
- Maximum 220ms delay variance between E1 link
- Unbalanced E1/BNC or balanced E1/RJ45
- Fully compatible with FRM220A chassis
- SNMP management with FRM220A chassis
- LED Alarm indication & Auto-Negotiation
- Standalone RS232 console management via CH01M for iMUX4/iMUX8, CH02M for iMUX16
- Support MTU 1916 bytes

Specifications

E1 Interface	Framing	CCS+CRC (Framed)	Dimensions	Card: 155 x 42.1 x 88mm (D x W x H)	
	Standard	ITU-T G.703/G.704/G.706 & G.732, G.823		Weight	130g
	Bit rate	2.048Mbps± 50ppm (up to 5E1)		Temperature	0 ~ 50°C (Operating), -10 ~ 70°C (Storage)
	Line code	HDB3		Humidity	10 ~ 90% RH (non-condensing)
	Clock setting	Internal OSC or recovery clock		Certifications	CE, FCC
	Receive level	-43dB		MTBF	65,000 hrs
	Line impedance	75 ohm (BNC) / 120 ohm (RJ45)			
	Jitter Performance	Complies with ITU-T G.823			
	Pulse Mask	Complies with ITU-T G.703			
	Pulse amplitude	Nominal 2.37V ± 10%			
	Delay Variance	220ms			
	Connector	RJ45, BNC			
	Diagnostics	Digital remote loopback			
	Ethernet Interface	Standards		IEEE 802.3, 802.3u	
Ethernet Interface	Data rate	10/100Base-TX, Half/Full duplex			
	Connector	RJ45 10/100Base-TX			
Indications	Power, ALM, E1 signal loss, E1 Alarm(AIS, LOF, RAI, LOMF), LAN link /ACT, 10/100M, SD (100Base-FX)				
Power Input	12VDC				
Power Consumption	< 12W				

Application

-  Fiber
-  Ethernet
-  E1

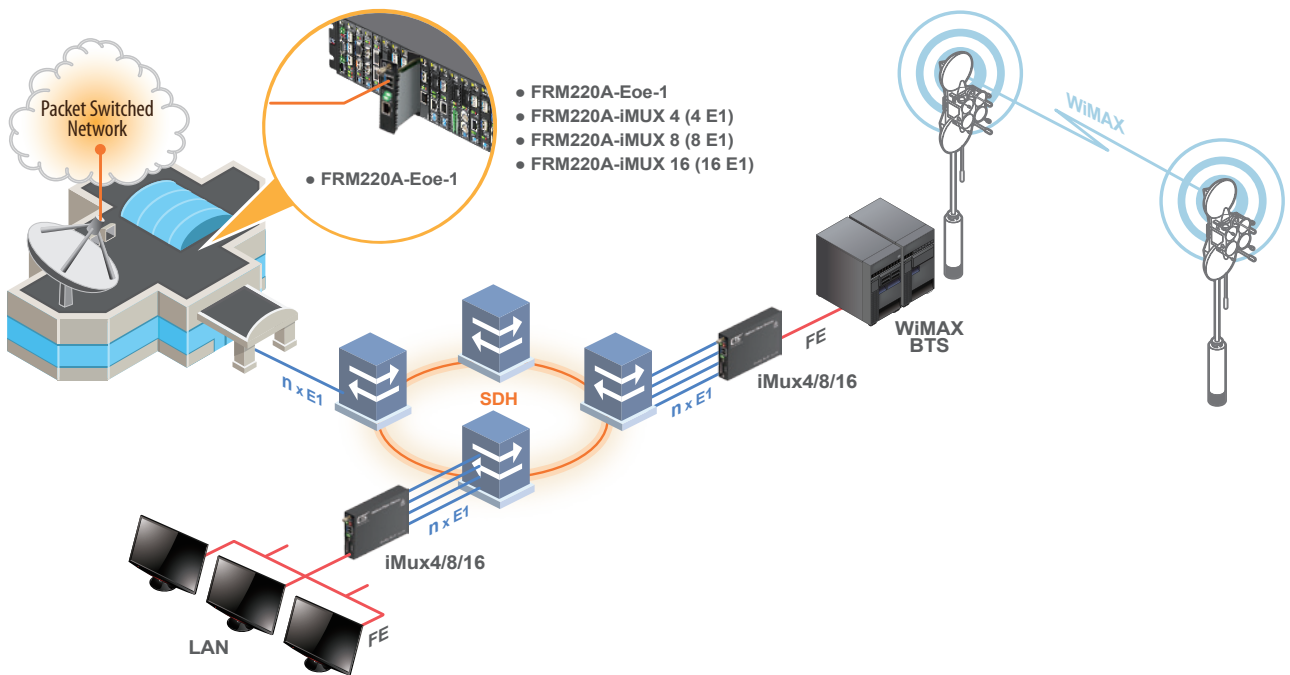

Ordering Information

Model Name	Description
FRM220A-iMux16T-R	10/100Base-TX to 16 E1 mux card with 16E1 RJ45 cable
FRM220A-iMux16T-B	10/100Base-TX to 16 E1 mux card with 16E1 BNC cable
FRM220A-iMux8T-R	10/100Base-TX to 8 E1 mux card with 8 E1 RJ45 cable
FRM220A-iMux8T-B	10/100Base-TX to 8 E1 mux card with 8 E1 BNC cable
FRM220A-iMux4T-R	10/100Base-TX to 4 E1 mux card with 4E1 RJ45 cable
FRM220A-iMux4T-B	10/100Base-TX to 4 E1 mux card with 4E1 BNC cable

Cable Type



RJ45 Cable



BNC Cable

FRM220A – iMux16T –
 Example: FRM220A – iMux16T – R

Note: This card may be locally configured by its own console when placed in CH02M with fan.
 When connected as a remote to a managed central chassis, this card supports in-band management and only needs a CH02 chassis.



FRM220-GFOM08

8x E1/T1+ GbE Fiber Multiplexer

The FRM220-GFOM08 is an 8 channel E1/T1 fiber multiplexer with an additional Gigabit Ethernet trunk, plus order wire and clear channel RS-232, constructed as a two slot wide card for the FRM220 series. When the FRM220-GFOM08 card is placed in the FRM220 rack with NMC, the management can view the converter card's status, type, version, fiber link status and alarms. Remote, fiber connected standalone card, can also be managed through in-band management via the chassis NMC. The card can be configured to enable or disable the port, reset the port, and provide local or remote diagnostic loopback. The 1+1 redundant optical aggregate of this multiplexer employs industry standard pluggable optics (SFP) operating at 1.25Gbps data rates. The SFP modules can be chosen to support single-mode, multi-mode, single fiber bi-directional or Coarse and Dense Wave Division Multiplexing (CWDM).

Feature

- 8 channels unframed E1/T1 (transparent)
- 10/100/1000Base-T Ethernet
- Auto MDI/MDIX & Auto-Negotiation or Force Mode
- Supports flow control 802.3x & 9K jumbo packets
- Supports link fault Pass-Through for Ethernet
- One clear channel RS232 up to 250Kbps(Async)
- 1+1 fiber protection, less than 50ms
- Supports Digital Diagnostics Monitoring Interface (DDMI) SFP
- AIS on signal loss on E1/T1 and fiber port
- Loopback test on E1/T1, RS232, fiber ports
- Supports local or remote In-band management (Monitor or Configure status) by SNMP manager and console port
- Supports Order wire Ear / Microphone port
- Supports On-Line F/W upgrade & Dying Gasp

Specifications

E1/T1 ports	Framing	Unframed (transparent)
	Bit Rate	E1:2.048 Mb/s , T1: 1.544Mb/s
	Line Code	E1:AMI/HDB3, T1: AMI/B8ZS
	Line Impedance	E1: Unbalanced 75 ohms (BNC)
		E1: Balanced 120 ohms (RJ-45)
		T1: Balanced 100 ohms (RJ-45)
	Receiver sensitivity	Short haul
	"Pulse" Amplitude	Nominal 2.37V+/-10% for 75 ohms
		Nominal 3.00V+/-10% for 120 ohms
	"Zero" Amplitude	+/-0.3V
	Internal Timing	+/-30 ppm
	Jitter Performance	According to ITU-T G.823
	Performance monitoring	According to ITU-T G.821
Standards	ITU-T G.703, G.704, G.706 and G.732	
Interface Connectors	RJ-45	
E1/T1 ports	Test Loops	LLB (Local Loop Back) NELB (Near End Loop Back)

E1/T1 ports	Test Loops	RLB (Remote Loop Back) RRLB (Request Remote Loop Back)
	Fiber	Connector SFP LC Data Rate 1.25 Gbps
Ethernet	Interface Type	10/100/1000Base-T
	Connector	RJ-45
	Standards	IEEE 802.3, 802.3u, 802.3ab
Indications	Duplex modes	full/half
	Power Input	FX1 Link, FX2 link, E1/T1 Mode/Link/Loopback test, Order wire phone indicator, LAN Link/Speed.
Power Consumption	12VDC	< 12W
Dimensions	Card: 155 x 42.1 x 88mm (D x W x H)	
Weight		200g
Temperature		0 ~ 50°C (Operating), -10 ~ 70°C (Storage)
Humidity		10 ~ 90% RH (non-condensing)
Certifications		CE, FCC

Application

Managed 8E1/T1 + Gigabit Ethernet Fiber Optical Multiplexer

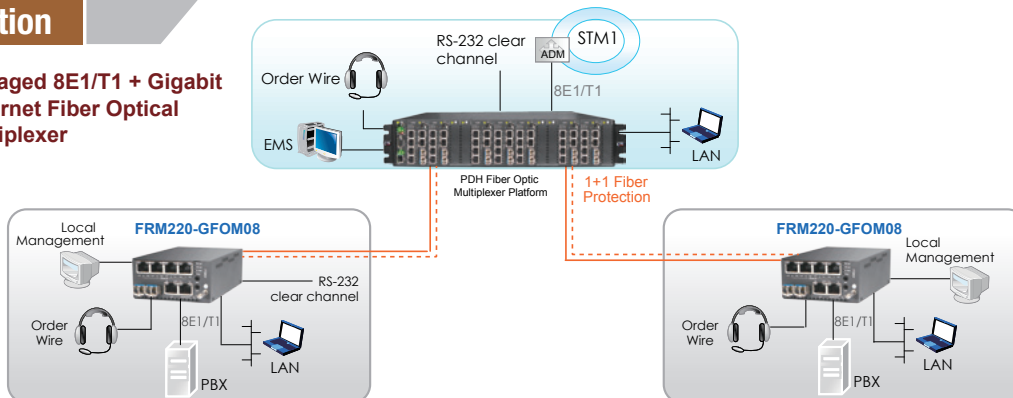

Ordering Information

Model Name	Description
FRM220-GFOM08-SR	8x E1/T1 RJ45 and 1000Mbps Ethernet Fiber Mux with 4x2E1 RJ45 cable, optional SFP module (Model : SFS-70xx-xx)
FRM220-GFOM08-SB	8x E1 BNC and 1000Mbps Ethernet Fiber Mux with 4x2E1 BNC cable, optional SFP module (Model : SFS-70xx-xx)



2E1 RJ45 cable

Note: This card may be locally configured by its own console when placed in CH02M with fan. When connected as a remote to a managed central chassis, this card supports in-band management and only needs a CH02M chassis.



FRM220-GFOM04

4X E1/T1 + GbE Fiber Multiplexer

The FRM220-GFOM04 is a 4 channel E1/T1 fiber multiplexer with an additional Gigabit Ethernet trunk, plus order wire and clear channel RS-232, constructed as a two slot wide card for the FRM220 series. When the FRM220-GFOM04 card is placed in the FRM220 rack with NMC, the management can view the converter card's status, type, version, fiber link status and alarms. Remote, fiber connected standalone card, can also be managed through in-band management via the chassis NMC. The card can be configured to enable or disable the port, reset the port, and provide local or remote diagnostic loopback. The 1+1 redundant optical aggregate of this multiplexer employs industry standard pluggable optics (SFP) operating at 1.25Gbps data rates. The SFP modules can be chosen to support single-mode, multi-mode, single fiber bi-directional or Coarse and Dense Wave Division Multiplexing (CWDM and DWDM).

Feature

- 4 channels unframed E1/T1 (transparent)
- 10/100/1000Base-T Ethernet
- Auto MDI/MDIX & Auto-Negotiation or Force Mode
- Supports flow control 802.3x & 9K jumbo packets
- Supports link fault Pass-Through for Ethernet
- One clear channel RS232 up to 250Kbps(Async)
- 1+1 fiber protection, less than 50ms
- Supports Digital Diagnostics Monitoring Interface (DDMI) SFP
- AIS on signal loss on E1/T1 and fiber port
- Loopback test on E1/T1, RS232, fiber ports
- Supports local or remote In-band management (Monitor or Configure status) by SNMP manager and console port
- Supports Order wire Ear / Microphone port
- Supports On-Line F/W upgrade & Dying Gasp

Specifications

E1/T1 ports	Framing	Unframed (transparent)
	Bit Rate	E1:2.048 Mb/s , T1: 1.544Mb/s
	Line Code	E1:AMI/HDB3, T1: AMI/B8ZS
	Line Impedance	E1: Unbalanced 75 ohms (BNC)
		E1: Balanced 120 ohms (RJ-45)
		T1: Balanced 100 ohms (RJ-45)
	Receiver sensitivity	Short haul
	"Pulse" Amplitude	Nominal 2.37V+/-10% for 75 ohms
		Nominal 3.00V+/-10% for 120 ohms
	"Zero" Amplitude	+/-0.3V
	Internal Timing	+/-30 ppm
	Jitter Performance	According to ITU-T G.823
	Performance monitoring	According to ITU-T G.821
Standards	ITU-T G.703, G.704, G.706 and G.732	
Interface Connectors	RJ-45	
E1/T1 ports	Test Loops	LLB (Local Loop Back) NELB (Near End Loop Back)

E1/T1 ports	Test Loops	RLB (Remote Loop Back) RRLB (Request Remote Loop Back)
	Fiber	Connector SFP LC Data Rate 1.25 Gbps
Ethernet	Interface Type	10/100/1000Base-T
	Connector	RJ-45
	Standards	IEEE 802.3, 802.3u, 802.3ab
	Duplex modes	full/half
Indications	FX1 Link, FX2 link, E1/T1 Mode/Link/Loopback test, Order wire phone indicator, LAN Link/Speed.	
Power Input	12VDC	
Power Consumption	< 12W	
Dimensions	Card: 155 x 42.1 x 88mm (D x W x H)	
Weight	200g	
Temperature	0 ~ 50°C (Operating), -10 ~ 70°C (Storage)	
Humidity	10 ~ 90% RH (non-condensing)	
Certifications	CE, FCC	

Application

Managed 4E1/T1 + Gigabit Ethernet Fiber Optical Multiplexer

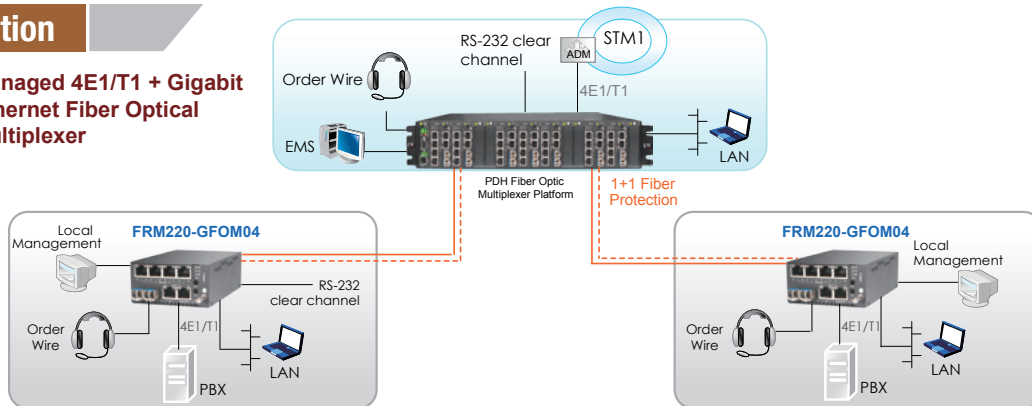

Ordering Information

Model Name	Description
FRM220-GFOM04-SR	4x E1/T1 RJ-45 and 10/100/1000Base-T Ethernet Fiber Optic Multiplexer (optional SFP module)
FRM220-GFOM04-SB	4x E1 BNC and 10/100/1000Base-T Ethernet Fiber Optic Multiplexer (optional SFP module)

Connector Type
FRM220 – GFOM04 – □□
 Example: FRM220 – GFOM04 – SR

Note: This card may be locally configured by its own console when placed in CH02M with fan. When connected as a remote to a managed central chassis, this card supports in-band management and only needs a CH02M chassis.



FRM220-FOM04

4x E1/T1+ FE Fiber Multiplexer

The FRM220-FOM04 is a 4 channel E1/T1 fiber multiplexer with an additional wire speed 100M Ethernet trunk, plus order wire and clear channel RS-232, constructed as a two slot wide card for the FRM220 series. When the FRM220-FOM04 card is placed in the FRM220 rack with NMC, the management can view the converter card's status, type, version, fiber link status and alarms. Remote, fiber connected standalone card, can also be managed through in-band management via the chassis NMC. The card can be configured to enable or disable the port, reset the port, and provide local or remote diagnostic loopback. The 1+1 redundant optical aggregate of this multiplexer employs industry standard pluggable optics (SFP) operating at OC3/STM- 1 data rates (155M). The SFP modules can be chosen to support single-mode, multi-mode, single fiber bi-directional or Coarse and Dense Wave Division Multiplexing (CWDM and DWDM).

Feature

- 4 channels unframed E1/T1 (transparent)
- 10/100Base-TX Ethernet (100M wirespeed)
- Auto MDI/MDIX & Auto-Negotiation or Force Mode
- Supports flow control 802.3x & 9K jumbo packets
- Supports link fault Pass-Through for Ethernet
- One clear channel RS232 up to 250Kbps(Async)
- 1+1 fiber protection, less than 50ms
- Supports Digital Diagnostics Monitoring Interface (DDMI) SFP
- AIS on signal loss on E1/T1 and fiber port
- Loopback test on E1/T1, RS232, fiber ports
- Supports local or remote In-band management (Monitor or Configure status) by SNMP manager and console port
- Supports Order wire Ear / Microphone port
- Supports On-Line F/W upgrade & Dying Gasp

Specifications

E1/T1 ports	Framing	Unframed (transparent)
	Bit Rate	E1:2.048 Mb/s , T1: 1.544Mb/s
	Line Code	E1:AMI/HDB3, T1: AMI/B8ZS
	Line Impedance	E1: Unbalanced 75 ohms (BNC cable)
		E1: Balanced 120 ohms (RJ-45)
		T1: Balanced 100 ohms (RJ-45)
	Receiver sensitivity	Short haul
	"Pulse" Amplitude	Nominal 2.37V+/-10% for 75 ohms Nominal 3.00V+/-10% for 120 ohms
	"Zero" Amplitude	+/-0.3V
	Internal Timing	+/-30 ppm
	Jitter Performance	According to ITU-T G.823
	Performance monitoring	According to ITU-T G.821
	Standards	ITU-T G.703, G.704, G.706 and G.732
Interface Connectors	RJ-45	
E1/T1 ports	Test Loops	LLB (Local Loop Back) NELB (Near End Loop Back)

E1/T1 ports	Test Loops	RLB (Remote Loop Back) RRLB (Request Remote Loop Back)
Fiber	Connector	SFP LC
	Data Rate	155 Mbps
Ethernet	Interface Type	10/100Base-TX
	Connector	RJ-45
	Standards	IEEE 802.3, 802.3u
	Duplex modes	full/half
Indications	FX1 Link, FX2 link, E1/T1 Mode/Link/Loopback test, Order wire phone indicator, LAN Link/Speed.	
Power Input	12VDC	
Power Consumption	< 7W	
Dimensions	Card: 155 x 42.1 x 88mm (D x W x H)	
Weight	200g	
Temperature	0 ~ 50°C (Operating), -10 ~ 70°C (Storage)	
Humidity	10 ~ 90% RH (non-condensing)	
Certifications	CE, FCC	

Application

Managed 4E1/T1 + Fast Ethernet Fiber Optical Multiplexer

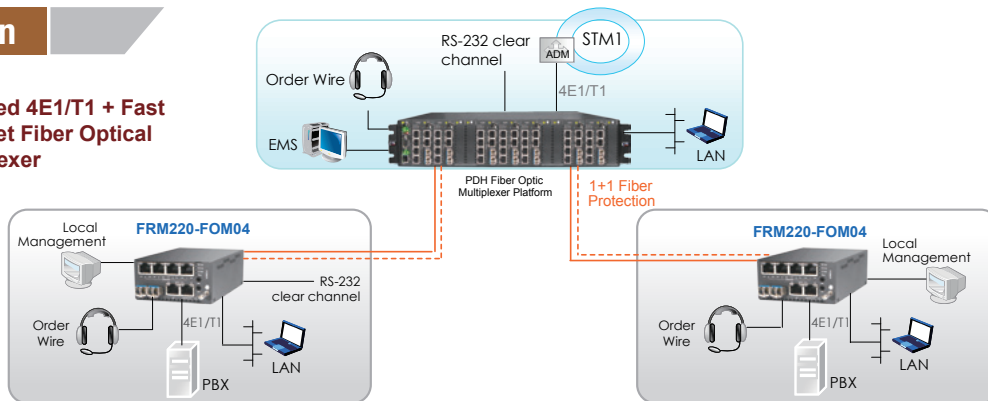

Ordering Information

Model Name	Description
FRM220-FOM04-SR	4 x E1/T1 RJ-45 and 100Mbps Ethernet Fiber Optic Multiplexer(optional SFP module)
FRM220-FOM04-SB	4x E1 BNC and 100Mbps Ethernet Fiber Optic Multiplexer(optional SFP module)

FRM220 – FOM04 –
 Example: FRM220 – FOM04 – SR

Note: This card may be locally configured by its own console when placed in CH02M with fan. When connected as a remote to a managed central chassis, this card supports in-band management and only needs a CH02M chassis.



FRM220-FOM01

E1/T1 + FE Fiber Multiplexer

The FRM220-FOM01 is a single channel E1/T1 fiber multiplexer with an additional wire speed 100M Ethernet trunk, plus clear channel RS-232, for placement the FRM220 series. When the FRM220-FOM01 card is placed in the FRM220 rack with NMC, the management can view the converter card's status, type, version, fiber link status and alarms. Remote, fiber connected standalone card, can also be managed through in-band management via the chassis NMC. The card can be configured to enable or disable the port, reset the port, and provide local or remote diagnostic loopback. The optical aggregate of this multiplexer employs either a fixed transceiver or industry standard pluggable optics (SFP) operating at OC3/STM-1 data rates (155M). The SFP modules can be chosen to support single-mode, multi-mode, single fiber bi-directional or Coarse and Dense Wave Division Multiplexing (CWDM and DWDM).

Feature

- 1 channel unframed E1/T1 (transparent)
- 10/100Base-TX Ethernet (100M wirespeed)
- Auto MDI/MDIX & Auto-Negotiation or Force Mode
- Supports flow control & 9K jumbo packets
- Supports link fault Pass-Through for Ethernet
- Supports Digital Diagnostics Monitoring Interface (DDMI) SFP
- Loopback test on E1/T1, fiber ports
- Supports local or remote In-band management by SNMP manager
- Local management by console port via FRM220-CH01M chassis
- Supports On-Line F/W upgrade & Dying Gasp

Specifications

E1/T1 ports	Framing	Unframed (transparent)
	Bit Rate	E1:2.048 Mb/s, T1: 1.544Mb/s
	Line Code	E1:AMI/HDB3, T1: AMI/B8ZS
	Line Impedance	E1: Unbalanced 75 ohms (BNC)
		E1: Balanced 120 ohms (RJ-45)
		T1: Balanced 100 ohms (RJ-45)
	Receiver sensitivity	Short haul
	"Pulse" Amplitude	Nominal 3.37V+/-10% for 75 ohms
		Nominal 3.00V+/-10% for 120 ohms +/-0.3V
	"Zero" Amplitude	w/external clock card option
	Internal Timing	+/-30 ppm
	Jitter Performance	According to ITU-T G.823
	Performance monitoring	According to ITU-T G.821
	Standards	ITU-T G.703, G.704, G.706 and G.732
E1/T1 ports	Interface Connectors	RJ-45
	Test Loops	LLB (Local Loop Back)
		RLB (Remote Loop Back)

Fiber	Connector	SFP LC
	Data Rate	155 Mbps
Ethernet	Interface Type	10/100Base-TX
	Connector	RJ-45
	Standards	IEEE 802.3, 802.3u
	Duplex modes	full/half
Indications	Power FX Link, E1/T1 Mode/Link/Loopback test, LAN Link/Speed	
Power Input	12VDC	
Power Consumption	< 4W	
Dimensions	Card: 155 x 20.8 x 88mm (D x W x H)	
Weight	130g	
Temperature	0 ~ 50°C (Operating), -10 ~ 70°C (Storage)	
Humidity	10 ~ 90% RH (non-condensing)	
Certifications	CE, FCC	

Application

Managed E1/T1 + Fast Ethernet Fiber Optical Multiplexer

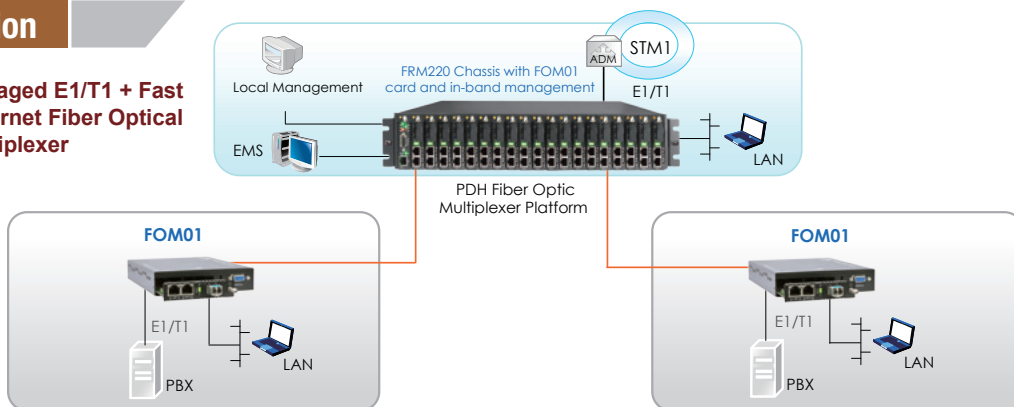

Ordering Information

Model Name	Description
FRM220-FOM01-SR	E1/T1 RJ-45 and 100Mbps Ethernet Fiber Optic Multiplexer (optional SFP module)
FRM220-FOM01-SB	E1 BNC and 100Mbps Ethernet Fiber Optic Multiplexer (optional SFP module)

Connector Type Connectivity Distance

FMC220 – FOM01 – □□ – □□□□□□

Example: FMC220 – FOM01 – SR – SC002

Note: This card must use CH01M with serial console, to configure standalone settings. When connected as a remote to a managed central chassis, this card supports in-band management and only needs a CH01 chassis.



FRM220-DS3/E3

DS3/E3 over Fiber

The FRM220-DS3/E3 is a fiber modem that works in pairs to transparently extend DS3, E3 or STS-1 transmissions over optical fiber. By utilizing pluggable SFP transceivers (155Mbps), these converters may be easily deployed on multimode or single mode fiber, at a distance up to 120km, or over a single core fiber using BiDi (WDM) SFP modules. The DS3/E3 connections utilize industry standard BNC connections for transmit and receive via coaxial cables. When the FRM220-DS3/E3 card is used standalone in a single slot chassis, DIP switches may be used for configuration and loopback control. When placed in a single slot chassis with console port, an easy to maneuver user menu is available via terminal to configure, monitor, and run diagnostic loop back functions. The EOC (embedded operations channel) allows in-band management to control the remotely connected modem over a working fiber link. When the FRM220-DS3/E3 card is placed in the FRM220 rack with SNMP management, the management can configure and view the local and remote converter cards' status, type, version, fiber link status and alarms.

Feature

- In-band network Managed via Terminal, web or SNMP in FRM220 chassis
- DS3/E3 Coax (BNC) to Fiber SFP fiber modem
- Supports AIS (Alarm Indication Signal)
- User selectable E3 or DS3 setting
- Electrical and optical Loop back tests
- Standalone RS232 console management via CH01M

Specifications

Optical Interface	Connector	SFP : LC (Uses standard 100Base-X/OC-3 SFP)	Electrical Interface	Connector	75 ohm Coax, TX output min: +2.5dBm max : +9.1dBm
	Data Rate	DS3/T3 = 44.7 Mbps; E3 = 34.4 Mbps		RX input min: -9.7dBm, max +10.5dBm	
Line Coding	Distance	MM 2km, SM 15/30/50/80/120km, WDM 20/40/60/80km	Standards	ANSI, ITU-TS, ETSI, AT&T, G.703, G.921 & G.955	
	Wavelength	1310nm, 1550nm, CWDM 1471nm ~ 1611nm	Indications	Power, Coax link, coax loop-back, AIS on coax link; FX link, fiber loop-back, AIS on FX link	
	Dimensions	Card: 155 x 20.8 x 88mm (D x W x H)	Power Input	12VDC	
Weight	120g		Power Consumption	< 6W	
Temperature	0 ~ 50°C (Operating), -10 ~ 70°C (Storage)				
Certification	CE, FCC				

Application

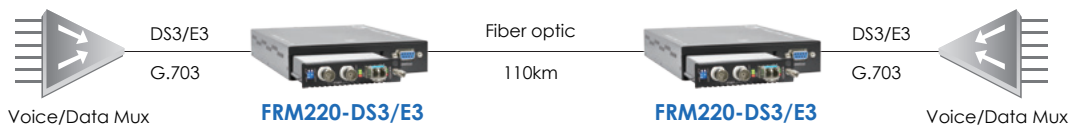

Integrate Voice & Data on Network

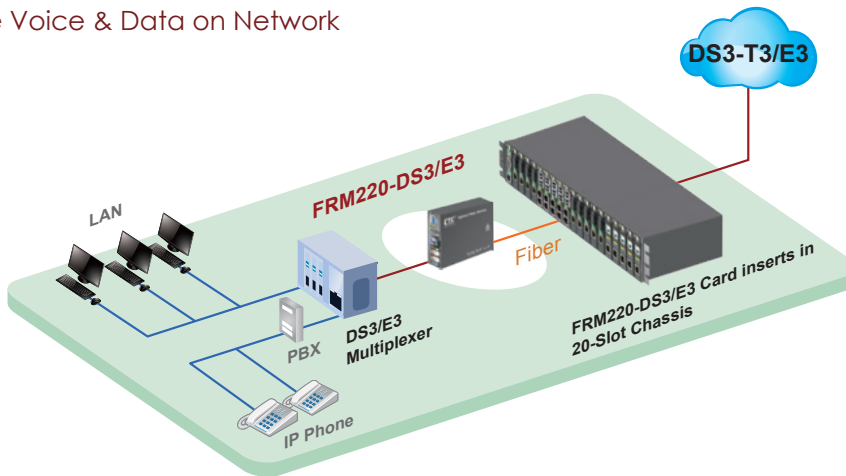

Ordering Information

Model Name	Description
FRM220-DS3/E3	DS3/E3 Coax (BNC) to Fiber SFP fiber media converter

Note: This card must use CH01M, with serial console, to configure standalone settings. When connected as a remote to a managed central chassis, this card supports in-band management and only needs a CH01 chassis.



FRM220-Serial RS232/485 over Fiber

The FRM220-Serial provides a fiber modem solution to extend asynchronous RS-232, RS-422 or RS-485 transmission distance up to 2km over multimode fiber or up to 120km over single mode fiber. The converter is equipped with multiple interface circuits for connection to RS-232 or RS485/422 (2 or 4 wire, full or half duplex). The FRM220-Serial secures data transmission over EMI resistant fiber at speeds up to 256kbps for RS-232 or up to 1024kbps for RS485/422. When the FRM220-Serial/485 card is placed in the FRM220 rack with SNMP management, in-band management allows configuring and viewing the card and remote converter's status, type, version, fiber link status, data link status and alarms. When placed in a single slot chassis and used standalone without management, the card may be configured by DIP switches.

Feature

- Extend asynchronous serial transmission up to 120km over fiber
- In-band network management via terminal, Web or SNMP in FRM220-CH20 chassis
- Software selectable data interface for RS-232/ 485
- Software selectable three or five wires RS-232
- Speeds up to 256kbps for RS-232 (Async. mode)
- Speeds up to 1Mbps for RS-485
- Standalone RS232 console management via CH01M
- Software selectable two wires (half duplex) or four wires (full duplex) RS-485

Specifications

Optical Interface	Connector	SFP LC	Electrical Interface	Connector	6 pins Terminal block
	Data rate	36.864Mbps		Data Signal Formats	RS-485 2-wire RS-232 RTS/CTS 5-wire RS-232 3-wire
	Line coding	Scrambled NRZ		Baud Rate	RS-422, RS-485 up to 1024kbps RS-232 up to 256kbps
	Bit Error Rate	Less than 10 ⁻¹⁰		Bit Error Rate	Less than 10 ⁻¹⁰
	Fiber	MM 62.2/125µm, 50/125µm SM 9/125µm		Power Consumption	< 6W
	Distance	MM 2km, SM 15/30/50km WDM 20/40km		Dimensions	Card: 155 x 20.8 x 88mm (D x W x H)
	Wavelength	MM 1310nm, SM 1310, 1550nm WDM 1310Tx/1550Rx (type A) 1550Tx/1310Rx (type B)		Weight	130g
Standards	EIA/TIA RS-485, RS-232	Temperature	0 ~ 50°C (Operating), -10 ~ 70°C (Storage)		
LEDs	Power, FX Link, DI, DO, Test	Humidity	10 ~ 90% non-condensing		
Power Input	12VDC	Certification	CE, FCC		
		MTBF	65,000 hrs		

Application

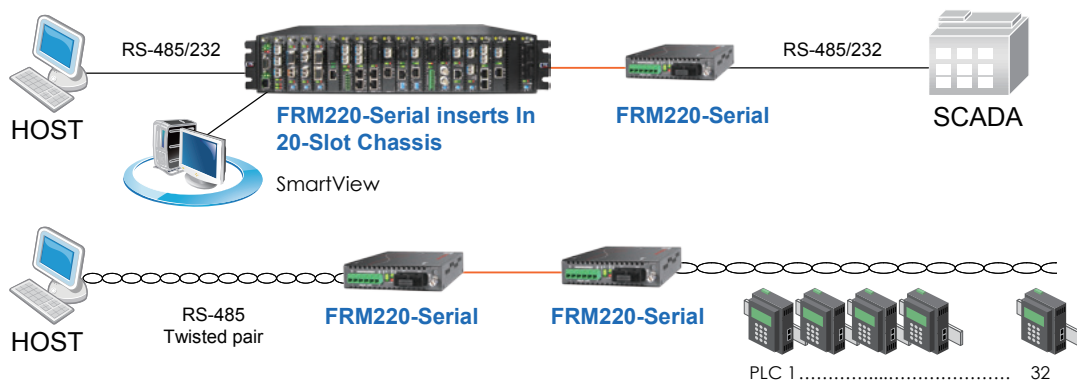

Ordering Information

Model Name	Description
FRM220-Serial	RS-232/485 fiber converter
FRM220-Serial-SFP	RS-232/485 fiber converter (SFP module not included)
Connector Type	Connectivity Distance

SC,ST,FC (Not Applicable for SFP Type) 002: 2km 015: 15km 030: 30km 050: 50km
 20A: WDM 20km A type 20B: WDM 20km B type 40A: WDM 40km A type 40B: WDM 40km B type

Connector Type Connectivity Distance
FRM220 – Serial –
 Example: FRM220 – E1/T1R – SC002

Note: This card may be set by DIP switch and placed in CH01 chassis, or set by serial console if placed in CH01M chassis. When connected as a remote to a managed central chassis, this card supports in-band management and only needs a CH01 chassis.



FRM220-FTEC

E1/T1 Cross Rate Converter

2

E1/T1 Cross Rate Converter

The FRM220-FTEC is a T1 (US Standard) /E1 (European Standard) converter and timeslot cross connect which enables conversion between one T1 signal and one E1 signal. T1 and E1 signals with framing employ u-Law and A-Law compander encoding principles respectively and encode those analog (voice) signals into 64kbps digital data. The T1 interface supports D4(SF) or ESF frame formats with B8ZS or AMI line code. The E1 interface supports CCS (PCM31) or CAS (PCM30) framing without CRC-4 and framing with CRC-4. The line coding is HDB3.

Tests and diagnostics can easily be performed from the local console interface or via Web based management of the FRM220. Diagnostics include T1 local/remote and E1 local/remote loop back. When placed in a single slot chassis and used standalone without management, the card may be configured by DIP switches.

Feature

- Converts between T1 and E1 data and signaling
- Enable equipment to operate at T1 and E1 rates
- Supports G.802 Annex B (T1 over E1)
- Configures A-law/ μ -law and signaling conversion
- Transparent conversion at 64kbps timeslot level
- Controlled slip for buffer over or under flow
- 24 time slots of T1 Nx64 can be inserted into E1 Nx64, 30/CAS or 31/CCS timeslots

Specifications

E1 Interface	Framing	CAS/PCM30 or CCS/PCM31 selectable	LEDs	PWR, Sys, Test, T1/E1		
	Bit rate	2.048Mbps		Standard	ITU-T G.703, G.704, G.706, G.823, G.824, ANSI T1.403	
	Line Code	HDB3			Power	12VDC
	Line Impedance	75 ohm (BNC) / 120 ohm (RJ-45)		Power Consumption		< 6W
	CRC check	CRC-4 enable/disable			Dimensions	Card: 155 x 20.8 x 88mm (D x W x H)
	Pulse amplitude	Nominal 2.37V \pm 10% for 75ohm Nominal 3.00V \pm 10% for 120ohm		Weight		130g
	Zero amplitude	\pm 0.1V			Temperature	0 ~ 50°C (Operating), -10 ~ 70°C (Storage)
	Connector	RJ-45		Humidity		10 ~ 90% non-condensing
	T1 Interface	Framing			D4, ESF selectable	Certification
		Bit rate		1.544Mbps	MTBF	
Line Code		B8ZS / AMI				
Equalization		0 ~ 655 feet settable				
		Voice channel sample rule μ -Law				
CRC check		CRC-6 when ESF				
Line Impedance		100 ohms				
Transmit Pulse level		3.0V \pm 10%,				
Receive signal level	0 ~ -10dB					
Connector	RJ-45					

Application



Ordering Information

Model Name	Description
FRM220-FTEC	E1/T1 Cross rate converter

Note: This card must use CH01M, with serial console, to configure standalone settings. For standalone SNMP management, place this card in CH02/NMC chassis.



FRM220-E1/DATA

E1 to Data

The FRM220-E1/Data is a single port G.703/704 Fractional E1 DSU/CSU card for the FRM220/220A Series Platform Media Converter Rack. The converter supports Unframed, PCM31, PCM31+CRC4, PCM30, and PCM30+CRC4 framing modes. The clock source may be selected internally, recovered from received E1 signal, externally from the Data port or transparent. The data port interface utilizes a single hi-density 26pin connector. Cable solutions are provided for RS-530/449, X.21, V.35 and RS-232. The unit can recognize the cable type attached and automatically self-configure the interface circuits. Choosing from one of two model types, the E1 connection is either unbalanced 75 ohm with two BNC connectors or balanced 120 ohm with one RJ-45 connector. When the FRM220-E1/Data card is placed in the FRM220 rack with SNMP management, the management can view the converter card's status, type, version, E1 link status and alarms. The card can be configured to enable or disable the port, reset the card, set clocking, frame mode, interface type and provide analog or digital diagnostic loopbacks. A unique feature of the FRM220-E1/Data is the use of a common card design which may either be inserted in the FRM220-CH01 single slot chassis as a stand-alone modem or as a card when placed in the FRM220-CH20 managed rack.

Feature

- Supports Fractional E1 and Unframed E1 services with V.35/X21/RS530 adapter cable
- I/O connectors all located on front panel
- Multiple clock source selection and remote loopback
- (Internal or External: E1 recovery, DTE or DCE)
- Unbalanced E1/BNC or balanced E1/RJ45
- Fully compatible with FRM220-CH20 and FRM220A chassis
- SNMP management with FRM220-CH20 chassis
- LED Alarm indication
- Standalone RS232 console management via CH01M

Specifications

E1 Interface	Framing	Framed/Unframed	Serial Interface	Standards	ITU-T, E1A
	Standards	ITU-T G.703/G.704/G.706 & G.732, G.823		Data rate	Nx56 / Nx64
	Bit rate	2.048Mbps± 50ppm		Connector	HDB26F w/ adapter cable for Data
	Line code	HDB3		LEDs	Power, TD, RD, RTS, DCD, TX Clock loss, Signal loss, Sync loss, Alarm, test error
	Clock setting	Internal OSC or recovery clock			Power
	Receive level	-43dB		Power Consumption	
	Line impedance	75 ohm (BNC) / 120 ohm (RJ45)			Dimensions
	Jitter	Complies with ITU-T G.823		Weight	
	Performance				Temperature
	Pulse Mask	Complies with ITU-T G.703		Humidity	
	Pulse amplitude	Nominal 2.37V ± 10%			Certifications
	Delay Variance	8ms		MTBF	
	Connector	BNC / RJ-45			
Diagnostics	Digital remote loopback				

Application

Managed E1 Access Unit

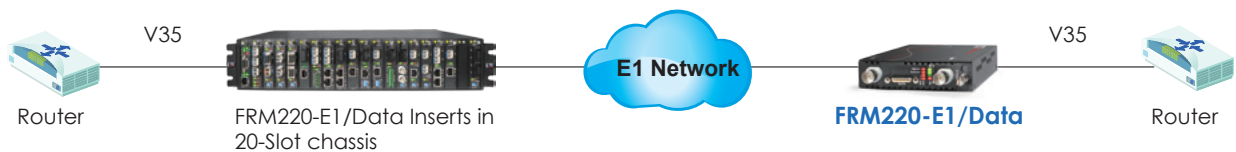

Ordering Information

Model Name	Description
FRM220-E1/V35-R	V35 to framed E1 RJ-45 with V35 cable
FRM220-E1/V35-B	V35 to framed E1 BNC with V35 cable
FRM220-E1/X21-R	X21 to framed E1 RJ-45 with X21 cable
FRM220-E1/X21-B	X21 to framed E1 BNC with X21 cable
FRM220-E1/RS530-R	RS530 to framed E1 RJ-45 with RS530 cable
FRM220-E1/RS530-B	RS530 to framed E1 BNC with RS530 cable
FRM220-E1/RS449-R	RS449 to framed E1 RJ-45 with RS449 cable
FRM220-E1/RS449-B	RS449 to framed E1 BNC with RS449 cable
FRM220-E1/RS232-R	RS232 to framed E1 RJ-45 with RS232 cable
FRM220-E1/RS232-B	RS232 to framed E1 BNC with RS232 cable

FRM220 - □□ / □□□ - □
 Example: FRM220 - E1/V35 - R

Note: This card may be set by DIP switch and placed in CH01 chassis, or set by serial console if placed in CH01M chassis. For standalone SNMP management, place this card in CH02/NMC chassis.



FRM220A-Eoe1

Ethernet Bridge over E1

- HDLC
- MTU 1522bytes
- Framed / Unframed E1

The FRM220A-Eoe1 is an Ethernet over E1 Bridge for cost-effective connection of 10/100Base-TX or 100Base-FX LANs over a single E1 transport. By using standard HDLC encapsulation, the FRM220A-Eoe1 is able to transmit up to a 2M bits Ethernet over an E1 link. The FRM220A-Eoe1 supports an E1 attenuation of up to 43 dB on twisted pair or coax cable, which provides an approximate operating range up to 2km (using 22AWG). The FRM220A-Eoe1 fully meets E1 specifications including ITU-T G.703 and G.823. The FRM220A-Eoe1 features diagnostic capabilities for performing remote loopback. The operator at either end of the line may test both the FRM220A-Eoe1 and the line in the digital loopback mode. The Ethernet copper interface supports auto-negotiation and auto MDI/MDIX, allowing plug-and-play Ethernet connection without any additional configuration. When placed in FRM220A system, the Ethernet may be aggregated to the chassis's built in Ethernet switch. When placed in a single slot chassis and used standalone without management, the card may be configured by DIP switch.

Feature

- Connects one Fast Ethernet over E1 links (64k~2048Kbps)
- Built-in HDLC bridge operates at WAN rate
- Auto-Negotiation
- Unbalanced E1/BNC or balanced E1/RJ45
- Fully compatible with FRM220A and FRM220 chassis
- SNMP management with FRM220A and FRM220 chassis
- LED Alarm indication
- Standalone RS232 console management via CH01M

Specifications

Optical Interface	Connector	1x9 (SC)
	Fiber	MM 62.2/125µm, 50/125µm, SM 9/125µm Rate: 155Mbps
	Distance	MM 2km, SM 15/30/50km, WDM 20/40km
	Wavelength	MM 1310nm, SM 1310, 1550nm WDM 1310Tx/1550Rx (type A) 1550Tx/1310Rx (type B)
Indications	LED (Power, FX Link, Phone Act, Test)	
Power Input	12VDC	
Power Consumption	< 6W	
Dimensions	Card: 155 x 20.8 x 88mm (D x W x H)	
Weight	120g	
Temperature	0 ~ 50°C (Operating), -10 ~ 70°C (Storage)	
Humidity	10 ~ 90% non-condensing	
Certification	CE, FCC	
MTBF	65,000 hrs	

Electrical Interface	Connector	RJ-11
	FXO modle	Impedance : 600 ohms Coding : 16 bits liner Loop Current : 10~100mA Ring Frequency : Acceptable 20 ~50Hz Insertion Loss: 0.0 ± 1.0dB at 1000Hz Impedance : 600 ohms
	FXS modle	Coding : 16 bits liner Dial: DTMF and Dial Pulse Battery Source: 48VDC ± 4V Ringing Waveform : Sine wave Ringing Frequency : 20/25/30/35/40/45/50 Hz selectable Ring Cadence: FXS to FXS: On / 1 sec, Off / 2 sec FXO to FXS; Reproduces the cadence detected by FXO Insertion Loss 0.0 ± 1.0dB at 1000Hz REN: 4.0B(Ring Equivalence Number)

Application

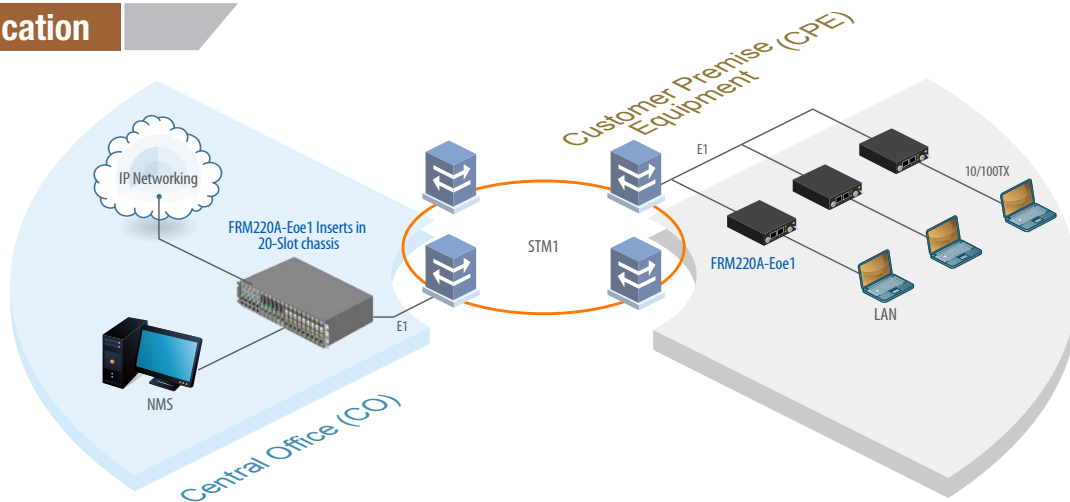

Ordering Information

Model Name	Description
FRM220A-Eoe1	10/100Base-TX to E1 HDLC bridge

Note: This card may be set by DIP switch and placed in CH01 chassis, or set by serial console if placed in CH01M chassis. When connected as a remote to a managed central chassis, this card supports in-band management and only needs a CH01 chassis.



FRM220-E1/T1

E1/T1 over Fiber

The FRM220-E1/T1 is a fiber media transceiver for G.703 E1/T1 transmissions designed for point-to-point use. The BNC model provides unbalanced 75 Ohm coaxial E1 connections while the RJ-45 model provides switchable balanced 120 Ohm E1 or 100 Ohm T1 connections over twisted pair wiring. When the FRM220-E1/T1 card is placed in the FRM220 rack with in-band management, the card status, type, version, fiber link status, E1 or T1 link status and alarms for both local card and remote unit can all be displayed. When set for E1 mode, the FRM220-E1/T1 also supports fractional (structured) E1 when connected to a remote FRM220-Data, synchronous data communications converter. In an E1 transmission network where end connection requires synchronous data communication such as V.35 or RS-530 (X.21, RS-449), these units eliminate the need for an extra CSU/DSU. When placed in a single slot chassis and used standalone without management, the card may be configured by DIP switches.

Feature

- In-band network Managed via Terminal, web or SNMP in FRM220 chassis
- T1/E1 RJ-45 (USOC RJ-48C) or E1 Coax (BNC) to Fiber converter
- Supports AMI or B8ZS/HDB3 line codes
- T1 supports unframed to FRM220-Data
- E1 supports unframed or fractional (N x 64k) to FRM220-Data
- User selectable E1 or T1 setting
- Electrical and optical Loop back tests
- Standalone RS232 console management via CH01M

Specifications

Optical Interface	Connector	1x9 (SC, ST, FC)
	Data rate	36.864Mbps
	Line coding	Scrambled NRZ
	Bit Error Rate	Less than 10 ⁻¹⁰
	Distance	MM 2km, SM 15/30/50km WDM 20/40km
	Wavelength	1310nm, 1550nm
Electrical Interface	Connector	RJ45 E1-120Ω, T1-100 Ω, BNC E1-75 Ω
	Data rate	E1: 2.048Mbps, T1:1.544Mbps
	Line Code	E1 HDB3/AMI, T1: B8ZS/AMI
	Cable type	Cat.3 or higher Twisted-Pair cable
Standards	E1	ITU-T G.703, G.704, G.706, G.732, G.823
	T1	ITU-T G.703, G.704, AT&T, TR-62411, ANSI T1.403

Indications	Power, FX-Link, E1/T1 SIG, Test, SYN, RD, TD, AIS (E1/T1R) Power, FX-Link, E1 SIG, Test(E1B)
Power Input	12VDC
Power Consumption	< 6W
Dimensions	Card: 155 x 20.8 x 88mm (D x W x H)
Weight	120g
Temperature	0 ~ 50°C (Operating), -10 ~ 70°C (Storage)
Humidity	10 ~ 90% non-condensing
Certification	CE, FCC
MTBF	65,000 hrs

Application

In-band Managed PDH Fiber Modem

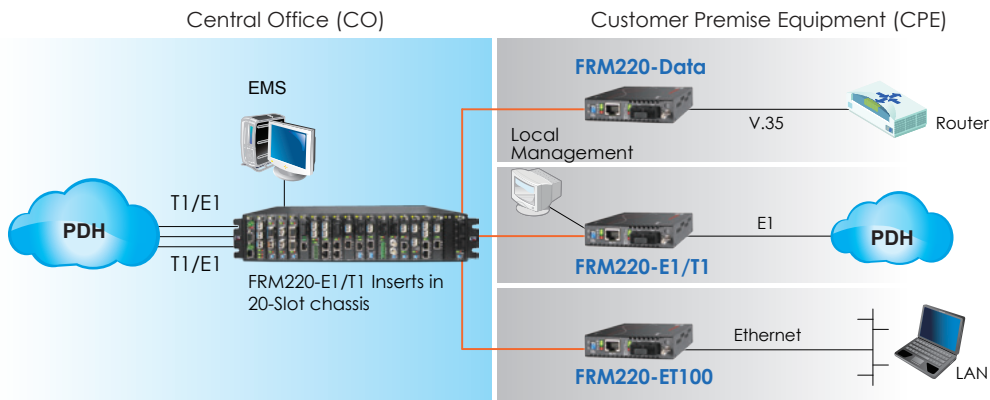

Ordering Information

Model Name	Description
FRM220-E1/T1R	E1/T1 RJ-45 fiber modem
FRM220-E1B	E1 BNC fiber modem
FRM220-E1/T1R-SFP	E1/T1 RJ-45 fiber modem (SFP module not included)
FRM220-E1B-SFP	E1 BNC fiber modem (SFP module not included)
Connector Type	Connectivity Distance

SC,ST,FC 002: 2km 015: 15km 030: 30km 050: 50km
 (Not Applicable for SFP Type) 20A: WDM 20km A type 20B: WDM 20km B type 40A: WDM 40km A type 40B: WDM 40km B type

Connector Type Connectivity Distance
FRM220 - □□ / □□□ - □□□□
 Example: FRM220 - E1/T1R - SC002

Note: This card may be set by DIP switch and placed in CH01 chassis, or set by serial console if placed in CH01M chassis. When connected as a remote to a managed central chassis, this card supports in-band management and only needs a CH01 chassis.



FRM220-DATA

RS232/530/V35 over Fiber

The FRM220-DATA is a fiber modem for high-speed (up to 8.192Mbps) synchronous or low speed synchronous and asynchronous data transmissions (V.35, RS-232, RS-530, X.21 or RS-449) over fiber optical media. When the FRM220-DATA card is placed in the FRM220 rack with SNMP management, in-band management allows viewing the card and remote converter's status, type, version, fiber link status, data link status and alarms. Both card and remote can be configured to enable or disable the port, reset the port, set the data rate, modify the clock mode, and initiate local or far end loop back tests. The FRM220-Data fiber modem may also be paired with the FRM220-E1/T1 for Nx64K transmissions. When placed in a single slot chassis and used standalone without management, the card may be configured by DIP switches.

Feature

- Synchronous or Asynchronous data over fiber
- In-band network management via terminal, web or SNMP in FRM220 chassis
- Software selectable interface, V.35, X.21, RS-530, RS-449, RS-232 (sync mode)
- Software selectable DCE or DTE mode
- User selectable data rate n x 64kbps, up to 9Mbps
- Independent clock mode setting, (internal, external, or recovery) for transmit and receive
- Electrical and optical loop back tests
- Compatible with FRM220-E1 on same fiber link for N x 64k
- Standalone RS232 console management via CH01M

Specifications

Optical Interface	Connector	SFP LC
	Data rate	36.864Mbps
	Line coding	Scrambled NRZ
	Bit Error Rate	Less than 10-10
	Distance	MM 2km, SM 15/30km, WDM 20/40km
	Wavelength	1310nm, 1550nm
Dimensions	Card: 155 x 20.8 x 88mm (D x W x H)	
Weight	130g	
Temperature	0 ~ 50°C (Operating), -10 ~ 70°C (Storage)	
Humidity	10 ~ 90% non-condensing	
Certification	CE, FCC	
MTBF	65,000 hrs	

Electrical Interface	Connector	HDB26F w/ adapter cable for V35
		X21, RS530, RS449,RS232
	Line Code	NRZ
	Baud Rate	RS-232 up to 384K async V.35/RS-530 up to 9152k sync where n=1 to 143 (64K ~ 9152Kkbps)
	Clock source	Internal, Recovery, External
	Standard	ITU-T
Indications	LED (Power, FX Link, RTS, Test , TD, RD, CTS, DCD)	
Power Input	12VDC	
Power Consumption	< 6W	

Application

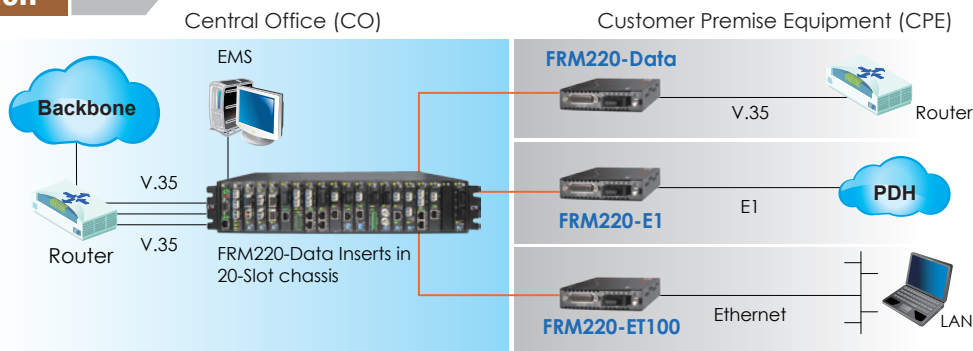

Ordering Information

Model Name	Description
FRM220-V35	V.35 to fiber with V35 cable
FRM220-X21	X.21 to fiber with X.21 cable
FRM220-RS530	RS530 to fiber with RS530 cable
FRM220-RS449	RS449 to fiber with RS449 cable
FRM220-RS232	RS232 to fiber with RS232 cable
FRM220-V35-SFP	V.35 to fiber with V35 cable (SFP module not included)
FRM220-X21-SFP	X.21 to fiber with X.21 cable (SFP module not included)
FRM220-RS530-SFP	RS530 to fiber with RS530 cable (SFP module not included)
FRM220-RS449-SFP	RS449 to fiber with RS449 cable (SFP module not included)
FRM220-RS232-SFP	RS232 to fiber with RS232 cable (SFP module not included)
Connector Type	Connectivity Distance
SC,ST,FC	002: 2km 015: 15km 030: 30km
(Not Applicable for SFP Type)	20A: WDM 20km A type 20B: WDM 20km B type 40A: WDM 40km A type 40B: WDM 40km B type

Note: This card may be set by DIP switch and placed in CH01 chassis, or set by serial console if placed in CH01M chassis. When connected as a remote to a managed central chassis, this card supports in-band management and only needs a CH01 chassis.

Interface Type Connector Type Connectivity Distance
FRM220 - [] [] [] [] - [] [] [] [] [] []
 Example: FRM220 - V35 - SC002



FRM220-ET100

10/100Base-TX Ethernet over E1 Fiber

FRM220-ET100 is a single Port Fiber WAN (TDM) card with built-in HDLC Ethernet Bridge for the FRM220 Series. The converter supports Nx 64 data rates from 64Kbps up to 2.048Mbps when linked by fiber to FRM220-Data or FRM220-E1/ T1 cards. The clock source may be selected internally or recovered from received fiber signal. The Ethernet port utilizes a single RJ- 45 connector. When the FRM220-ET100 card is placed in the FRM220 rack with SNMP management, the management can view the converter card's status, type, version, Ethernet link status and alarms. The card can be configured to enable or disable the port, reset the card, set clocking, data rate and provide digital diagnostic loopbacks. A unique feature of the FRM220-ET100 is the use of a common card design which may either be inserted in the FRM220-CH01 single slot chassis as a stand-alone modem or as a card when placed in the FRM220-CH20 managed rack.

Feature

- 1-Port Ethernet to HDLC (fiber) converter
- P2P Fiber link compatible with FRM220-E1/T1 and FRM220-Data
- Clock source (internal or external)
- Nx64k data rate (64kbps~2048kbps)
- Ethernet encapsulated with ISO 13239 standard HDLC
- Loop Back with integral BERT & LED indicators
- Firmware upgradeable, when placed in managed FRM220 chassis
- Interface connectors, RJ-45 for 10/100 Base-Tx
- Fixed optical for SC or ST, 2km(MM) to 120km(SM)

Specifications

TDM (fiber) Interface	Connector	1 x 9 (SC, ST, FC)	Indications	PWR, TD/RD Act, Test, Sys, Alarm, Error	
	Data rate	64~2048kb/s(nx64)		Power Input	12VDC
	Distance	MM 2km, SM 15/30/50km WDM 20/40km			Power Consumption
	Wavelength	MM 1310nm, SM 1310, 1550nm WDM 1310Tx/1550Rx (type A) 1550Tx/1310Rx (type B)		Dimensions	
Ethernet Interface	Standards	IEEE 802.3u, IEEE 802.3	Weight	130g	
	Data rate	10Mbps, 100Mbps	Temperature	0 ~ 50°C (Operating), -10 ~ 70°C (Storage)	
	Duplex mode	Half / Full duplex	Humidity	10 ~ 90% RH (non-condensing)	
	Connector	RJ-45	Certifications	CE, FCC	
Tests	E1 Loops	Remote Loop back	MTBF	75,000 hrs	

Application

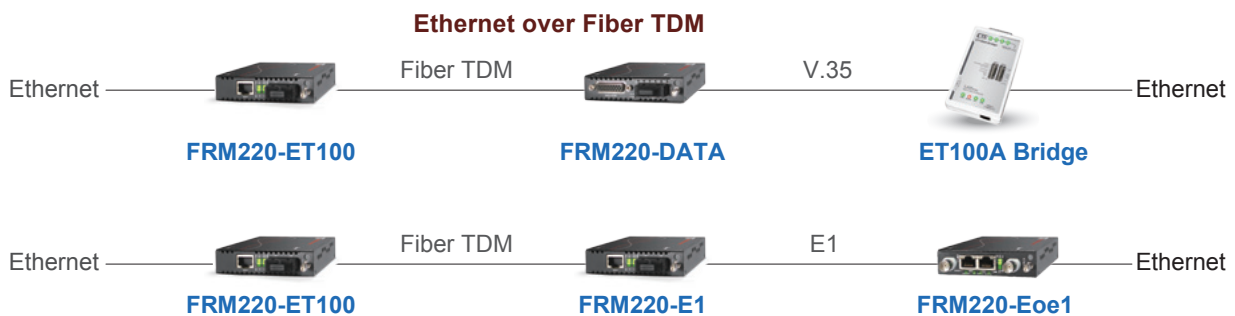

Ordering Information

Model Name	Description
FRM220-ET100	10/100Base-TX to E1 fiber modem
Connector Type	Connectivity Distance
SC,ST,FC	002: 2km 015: 15km 030: 30km 050: 50km 20A: WDM 20km A type 20B: WDM 20km B type 40A: WDM 40km A type 40B: WDM 40km B type

Connector Type Connectivity Distance

FRM220 – ET100 –

Example: **FRM220 – ET100 – SC002**

Note: This card may be set by DIP switch and placed in CH01 chassis, or set by serial console if placed in CH01M chassis. When connected as a remote to a managed central chassis, this card supports in-band management and only needs a CH01 chassis.