

# OPERATOR'S MANUAL

HEAVY DUTY



ECONOMY

## CHAIN HOIST

### 0.5 TON

### 1 TON

### 2 TON

**These Hand Chain Hoists  
meet or exceed  
the following  
standards:**

**CE  
ANSI B30.16**



P.O. Box 845, Winona, MN 55987  
Phone (800) 749-1064  
(507) 474-6250  
Tech Support (507) 457-3346  
Fax (507) 452-5217  
sales@ozliftingproducts.com  
www.ozliftingproducts.com

# Table of Contents

<b>Pg.2</b>	<b>Product Features and Benefits</b>
<b>Pg.3</b>	<b>Warranty/Warranty Policy</b>
<b>Pg.4</b>	<b>Important Information and Precautions</b>
<b>Pg.5</b>	<b>Warnings</b>
<b>Pg.6</b>	<b>Technical Information</b>
<b>Pg.7</b>	<b>Pre-Installation</b>
<b>Pg.8</b>	<b>Operation</b>
<b>Pg.9</b>	<b>Inspection</b>
<b>Pg.10</b>	<b>Inspection</b>
<b>Pg.11</b>	<b>Inspection</b>
<b>Pg.12</b>	<b>Inspection</b>
<b>Pg.13</b>	<b>Inspection</b>
<b>Pg.14</b>	<b>Maintenance</b>
<b>Pg.15</b>	<b>Parts List</b>
<b>Pg.16</b>	<b>Service Notes</b>

## Product Features and Benefits

- **All steel construction**
- **G80 Alloy load chain**
- **Minimum headroom**
- **Fully enclosed gear train**
- **Galvanized hand chain**
- **Weather protected automatic brake**
- **Powder coated paint protection**
- **Test certificate included**
- **Each unit tested to 150% of rated capacity**

# Warranty

All OZ ECONOMY hoists. are guaranteed to be free of defects in materials and workmanship for one year from date of shipment.

This does not apply to any product showing signs of misuse, overloading, alteration, improper maintenance, or negligence. Normal wear and tear of moving parts is excluded from this warranty.

If any one of our products fails during the first year of operating due to defective materials or workmanship it will be repaired or replaced at the discretion of OZ Lifting Products. The product will then be returned to the customer free of charge. If no defect is found the customer will be responsible for return shipping costs. Upon repair the product will be covered by the warranty for the remainder of the original warranty. OZ lifting will not be held liable for injuries to persons or property, death, incidental, consequential, or contingent damages whether negligent or deliberate arising from the use of the product. It is the sole responsibility of the owner to install and operate the product properly and safely.

This is OZ Lifting Product's only written warranty. This warranty is in lieu of all other warranties implied by law such as merchantability and fitness.

## Warranty Policy

Any product for which there is a warranty claim must be returned prepaid to an authorized OZ Lifting warranty depot along with proof of purchase.



### **For more information please contact:**

P.O. Box 845, Winona, MN 55987  
Phone (800) 749-1064  
(507) 474-6250  
Tech Support (507) 457-3346  
Fax (507) 452-5217  
sales@ozliftingproducts.com  
[www.ozliftingproducts.com](http://www.ozliftingproducts.com)

# Important Information and Precautions

This manual contains general instructions dealing with the normal installation, operation and maintenance of the products described herein.

This product should not be installed, operated, or maintained by any person who has not read all the contents of these instructions. Failure to read and comply with these instructions, warnings, or limitations noted might result in bodily injury, death, or property damage. Contact the distributor for further explanation if information is not fully understood.

It is the responsibility of the owner/user to install, test, maintain, and operate these products in accordance with OSHA regulations, other federal, state, and local regulations, and ANSI standards including:

- ANSI/ASME B30.16- Manually Operated Chain Hoists
- Other applicable volumes within ANSI/ASME B30

Only trained and qualified personnel shall operate and maintain this equipment.

## Maintain Records

Schedule and maintain records of regular inspection and maintenance of the product in compliance with ANSI standards.

Record your hoists Serial Number on the front cover of this manual to allow for easier referencing.

## Precautions

Do not use OZ Lifting products in conjunction with other equipment unless the system designer, manufacturer, installer, or user has put the necessary safety devices in place.

Modifications to upgrade, re-rate, or alter these products should only be authorized by the original manufacturer.

Hoists should be used for lifting loads only within their load ratings.

## These Chain Hoists meet or exceed the following standards:

**CE**  
**ANSI B30.16**



# Warnings

**Failure to read and comply with the following warnings may result in a hazardous situation that could lead to death, serious injury, or property damage.**

**Do Not** operate the hoist with anything other than manual hand power.

**Do Not** use lever hoist with extension on lever handle.

**Do Not** operate if hook latch is missing or not functioning properly.

**Do Not** lift more than the rated load.

**Do Not** operate the product when it is restricted from forming a straight line with the direction of loading.

**Do Not** operate with twisted, kinked, or damaged chain.

**Do Not** operate if chain is not seated in sheaves or sprockets.

**Do Not** wrap chain around load or use chain as a sling.

**Do Not** operate until load chain is seated correctly in the load sheave.

**Do Not** operate unless load is properly applied to the saddle or bowl of the hook.

**Do Not** operate if load is applied to the tip of the hook.

**Do Not** lift people.

**Do Not** lift loads over people.

**Do Not** operate beyond load chain's travel limits.

**Do Not** operate with side pulling or side loading of load to hoist.

**Do Not** operate a damaged or malfunctioning product.

**Do Not** remove, deface, or obscure warning labels.

**Do Not** leave a suspended load unattended, unless specific precautions are instituted.

**Do Not** lengthen chain or repair damaged load chain by welding.

**Do Not** use chain as an electrical or welding ground.

**Do Not** operate until personnel are warned of approaching loads and are cleared from the area.



# Technical Information

(0.5, 1 and 2 tons)

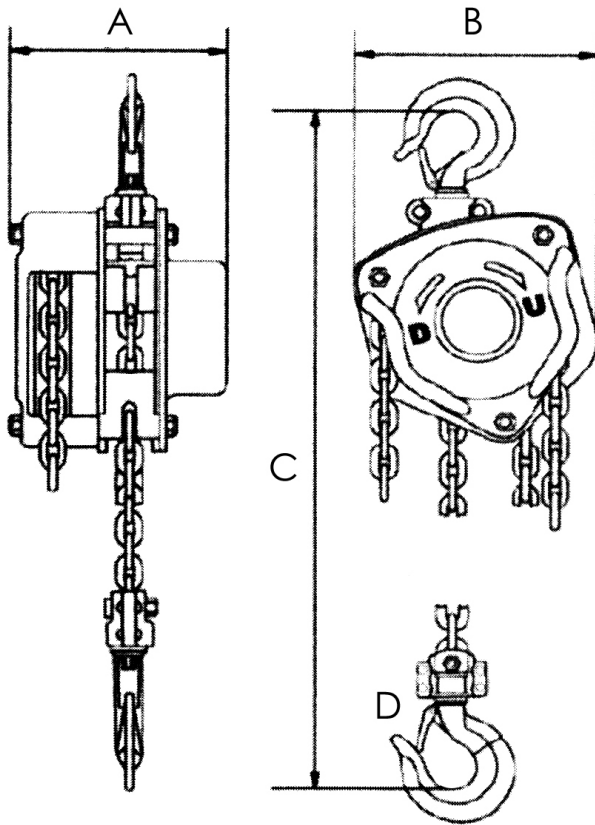

## Specification

Model	OZECON005	OZECON010	OZECON020
Capacity	0.5 ton	1 ton	2 ton
Effort required to lift rated load	48 lbs	72 lbs	75 lbs
Strands of load chain	1	1	1
Load chain diameter	5 mm	6 mm	8 mm
Dimensions	A	5.16 in	5.91 in
	B	5.38 in	5.73 in
	C	10.63 in	12.48 in
	D	1.23 in	1.26 in
Net Weight	14 lbs	19 lbs	32 lbs
Packaging	10"7"8"	10"7"8"	13"10"8"

\*Will custom rig

# Pre-Installation

Check for damage during shipment. Do not install or use a damaged product. Check and verify any structure or other equipment that will support the product has a rated load capacity equal to or greater than the rated load capacity of the product to be used.

## **Before initial operation:**

Read and comply with all instructions and warnings furnished with or attached to the product if applicable.

Check operation of the brake.

Where applicable, check that the chain is properly seated in sheaves and that the chain is not twisted, kinked, or damaged.

Correct all chain irregularities before use.

Make sure that all supporting structures are sufficient to support the hoist and the load.

Make sure the hoist is installed properly to a fixed point.

Check that all bolts, nuts, and cotter pins are securely in place.

## **Before each shift, where applicable:**

Inspect hooks for nicks, gouges, cracks, and signs of pulling apart or twisting.

Inspect hook latch for proper operation.

Check chain for kinks or twists.

Check operation of brake.

Replace warning label if missing or illegible.

## **Before operating:**

Be certain all personnel are clear of the load to be lifted and moved.

Make sure the load is clear of obstacles, machinery, or other obstructions before hoisting and operation.

Make sure the hoist operation area allows enough room for lever operation, a clear zone for the operator and other personnel to stand, and allows the frame to swivel freely on the upper hook.

# Operation

## Warnings & Precautions

Hoist operators should read and fully comprehend this entire manual and all warnings on the hoist before beginning hoist operation. If this manual is not read and followed completely injuries may occur.

### Operator Requirements:

Read and fully comprehend this entire manual before hoist operation.

Must be trained in proper hoist operation and dealing with potential malfunctions.

Should not operate hoist while under influence of alcohol, medications, or drugs. Should not operate the hoist while tired or distracted.

Should not operate hoist if they have a history of seizures or other medical issues that may interfere with hoist operation.

Should have proper coordination and vision.

### Prior to Operation be sure:

Hoist is clean and properly lubricated.

Hoist is in proper working condition and maintenance records are up to date.

Brake is functioning properly.

### During Hoist Operation:

Maintain secure footing to prevent slipping and injury while operating.

Confirm that hoist unit is attached securely to a support before operation.

Verify hook latches are not supporting any of the load.

Do not hold the chain during hoist operation.

Slowly take up the load, verifying it is well supported and balanced before proceeding.

## Hand Chain Hoist Operation

### Attaching the Load

1. If there are no twists in the chain proceed on to attach the lower hook to the load.
2. Do not use the chain to wrap around the load.
3. The load should be seated in the bowl of the hook and should not bear against the tip of the hook or latch.
4. The hook latch should be tightly closed against the hook tip
5. Assure that the upper and lower hooks form a straight line and frame is able to swivel.

### Lifting the Load

1. Pull chain clockwise.

### Lowering the Load

1. Pull chain counterclockwise.



# Inspection

In order to maintain quality operation of the product, a regular inspection schedule should be set up by each operator. All inspections should be reported and maintained in a dated record log. These records should be available to all personnel involved with the product, and should be made available to OZ Lifting Products when a warranty issue is in question.

## Definitions

The following definitions are from the ANSI/ASME B03.21 and will be used in the inspections procedure that follows.

**Designated Person-** a person who is selected or assigned as being competent to perform specific duties to which they are assigned.

**Qualified Person-** a person that by possession of a recognized degree or certificate of professional standing, or through extensive knowledge, training, and experience, has successfully demonstrated they are able to resolve problems relating to the subject matter and work.

**Normal Service-** service that involves operation with randomly distributed loads within the rated load limit, or uniform loads less than 65% of rated load for not more than 15% of the time.

**Heavy Service-** service that involves operation within the rated load limit that exceeds normal service.

**Severe Service-** service that involves normal or heavy service with abnormal operating conditions.

## Inspection Classifications

Initial inspection should be done on all new, modified, and repaired products in accordance with Table 1. Thereafter, items to be inspected are indicated in Table 1 by F (Frequent) or P (Periodic). For hoists exposed to more severe environmental conditions inspections should be more frequent.

### Frequent Inspections

The operator or other designated person performs frequent inspections by doing a visual examination and by listening for unusual sounds while product is operating. Frequent inspections are usually performed on the following schedule:

**Normal Service-** Monthly inspections

**Heavy Service-** Weekly to monthly inspections

**Severe Service-** Daily or before each use to weekly inspections

### Periodic Inspections

A designated person performs periodic inspections, which are more detailed inspections, by doing visual examinations of external and internal conditions. These inspections are done on the following schedule:

**Normal Service-** Yearly inspection

**Heavy Service-** Semi-annually inspections

**Severe Service-** Quarterly inspections

# TABLE 1 - INSPECTION CHART

In chart, **F** indicates Frequent Inspection, **P** indicates Periodic Inspection

LOCATION		CHECK FOR	F	P
Braking mechanism		Slipping under load	•	
		Hard to release	•	
Brake parts:	Brake Discs	Glazing		•
		Oil contamination		•
	Pawl: Ratchet	Excessive wear		•
	Pawl: Spring	Corrosion: stretch		•
Hook		Chemical damage	•	
		Operation	•	
		Deformation	•	
		Cracks (dye penetrant, magnetic particle, or other suitable detection method)		•
Hook retaining members Not tight or secure (Pins, Bolts, Nuts)		Not tight, secure or damaged		•
Hook Latch		Damaged; does not close	•	
Suspension Members (Sheaves, Hand-wheels, Chain attachments, Suspension bolts or pins)		Excessive wear		•
		Cracks	•	•
Gears		Distortion		•
		Broken or worn teeth		•
		Cracks		•
		Inadequate lubrication		•
Load Block: Suspension housing		Distortion	•	•
		Crack	•	•
Trolley: Supporting structure		Possible inability to continue supporting loads or damaged		•
Bolts, Nuts, Rivets		Not tight or secure		•
WARNING Labels		Removed or not legible	•	
Proper operation		Unusual sounds	•	

## IMPORTANT

Any deficiency found on this inspection chart should be corrected before the hoist is put back into service.

**Note: Following disassembly of the hoist during inspection, a load test is required by ANSI/ASME B30.16 and should be done before the product is put back into operation.**

# Hook Inspection

## Warnings:

1. Any OZ hook that requires replacement because of excessive bends, twists, or throat opening indicates abuse or overloading of the product. Therefore, other load-supporting components of the product should be inspected for possible damage when such conditions are found.
2. Never repair hooks by welding or reshaping. Heat applied to the hook will alter the original heat treatment of the hook material and reduce the strength of the hook.
3. Never weld handles or other attachments to the hook.

## Hook Inspection Procedure

Where applicable, inspect hooks and measure throat opening at least once a month. Between regular inspections daily inspections of the hooks should be done. Check for the following:

- Deformation, distortion, twisting, damage
- Missing, bent, or damaged hook latches
- Chemical damage, deformation, or cracks
- Greater than a 10-degree twist from the plane of unbent hook
- Excessive opening or seat wear

## Hook Latch

Hook latch inspection should include the following:

Replace hooks that are opened to an extent that the latch does not engage the tip.

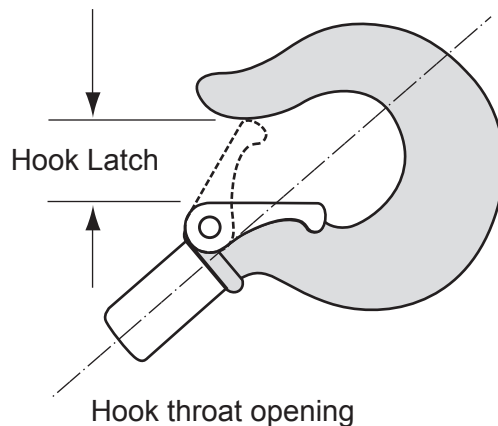

**Latch should have enough spring pressure to keep it tight against the tip of the hook and allow it to spring back to the tip when released**

Use the following chart to determine when the hook must be replaced. Replacement of the hook is necessary if any of the previous page problems are found or the maximum dimensions on the charts that follow are reached.

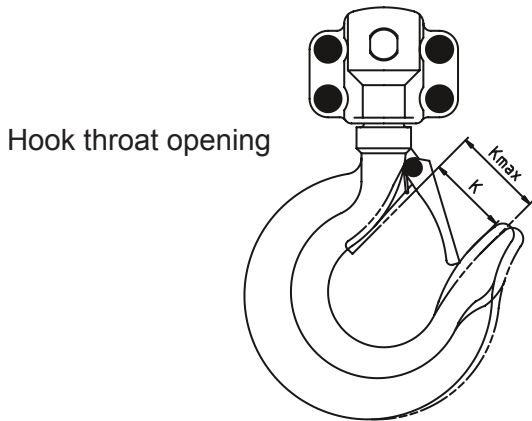

Size	Standard K (mm) (in)	Max K (mm) (in)
0.5 ton	28 (1.10")	30.5 (1.20")
1 ton	26 (1.02")	28.5 (1.12")
2 ton	32 (1.25")	35 (1.37")

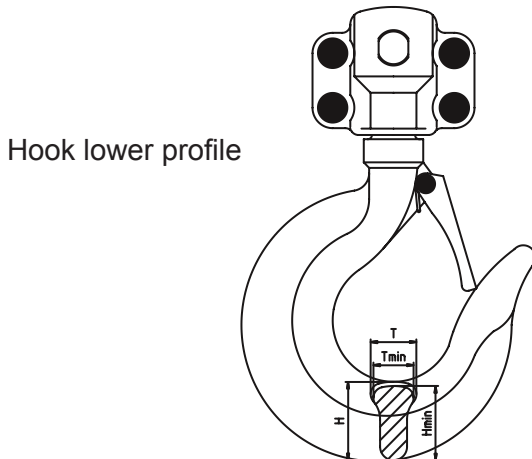

Size	Standard H (mm) (in)	Min H (mm) (in)	Standard T (mm) (in)	Min T (mm) (in)
.5 ton	19.1 (.75")	17.1 (.67")	13 (.51")	11.7 (.46")
1 ton	25.7 (1.01")	23.1 (.90")	16 (.62")	14.4 (.56")
2 ton	34.3 (1.35")	30.9 (1.21")	21 (.82")	18.9 (.74")

## Chain Inspection

Inspect chain before each use. Between regular inspections visually check on a daily basis the following:

- Clean chain before inspection using a non-caustic/non-acid solvent
- Lubrication of the chain may be necessary if it binds up or is noisy
- Chain feeds smoothly into and from the hoist and does not emit cracking noise when hoisting a load
- Visually examine link by link for any nicks, gouges, weld splatter, corrosion, or distorted links pay close attention to chain's contact points, which may show excessive wear.
- Test hoist with load and observe operation of chain over load sheaves.

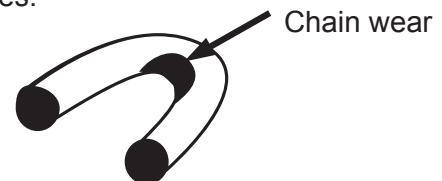

## Chain Warnings:

**Caution:** It must be recognized that certain factors in the usage of chain and attachments can be abusive and lessen the load that the chain or attachments can withstand. Some examples are twisting of the chain, disfigurement, deterioration by straining, usage, weathering and corrosion, rapid application of load or jerking applying excessive loads, and sharp corners cutting action.

Due to the crushing effect Grab Hooks have upon chain, the design factor of all assemblies must be reduced by 20% for Grab Hook applications.

**Use the following chart to determine when the chain must be replaced. Replacement of the entire chain is necessary if any of the previous page problems are found or the maximum dimensions on the charts that follow are reached.**

Load Chain - One link length

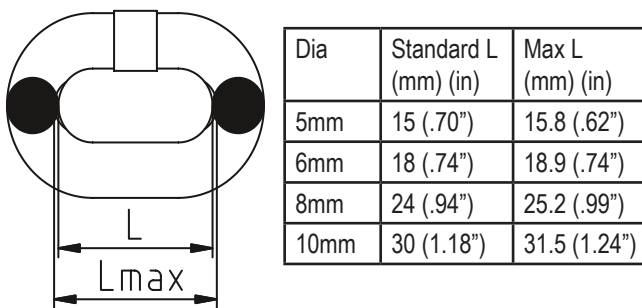

Load Chain - Diameter

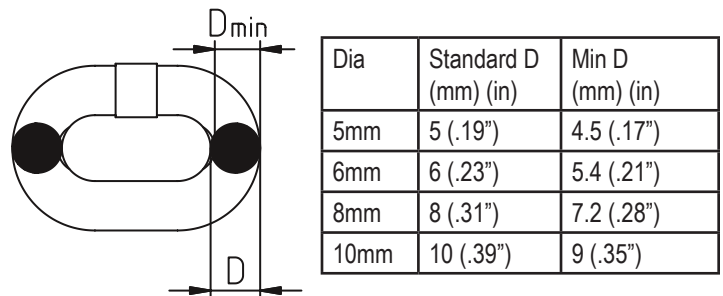

Load Chain - Five link length

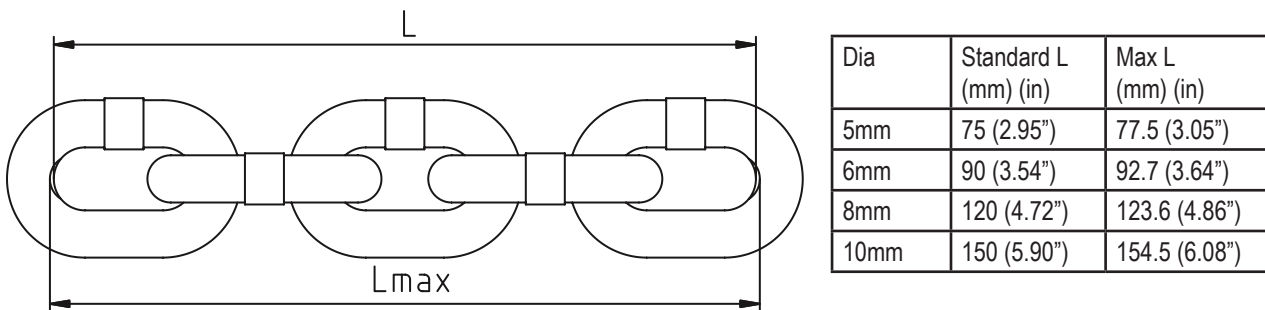

Hand Chain - One link length

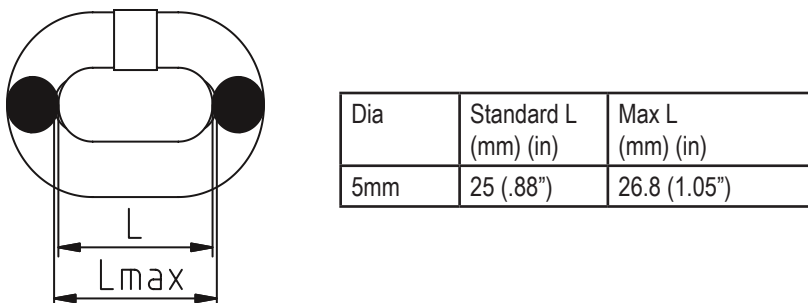

# Maintenance

## Lubrication

Proper lubrication with machine oil is necessary to increase the life of the chain. Lubrication should be done based on usage and on a regular basis. It may be necessary on a weekly basis for heavy use or monthly if used less often.

- Clean the chain with an acid free cleaning solution to remove debris.
- Apply oil to chain focusing on bearing surfaces such as interlink areas.
- Do not apply oil to braking surfaces.
- Gears and shafts run on roller bearings and do require lubrication.

## BRAKE & TOP HOOK INSPECTION & REPLACEMENT

### Disassembly

1. Remove the cover using a standard socket wrench.
2. Remove the hand chain from the wheel.
3. Use needle nose-pliers to straighten the cotter pin.
4. Remove nut.
5. Remove secondary cover (protects the brake).
6. Remove brake
7. To disassemble the top hook remove the pin and the hook comes off.

### Assembly

1. Chain should be well seated in the wheel.
2. Put the hand wheel back on.
3. Should hear a click, indicating the brake is set.
4. Hand tighten the nut.
5. Push the cotter pin back in.
6. Use pliers to flare the ears so it stays in place.
7. Reattach the hand chain; making sure the weld is out.
8. Attach cover and tighten locknuts.

## Storage of Hoist

Store the hoist in a clean dry area.

Maintain proper lubrication of the hoist while it is being stored.

If the hoist is malfunctioning clearly mark it before placing it in storage.

## Outdoor Hoist Usage

Store hoist indoors when not in use.

Frequently inspect the hoist for signs of corrosion due to environmental factors.

# Parts List

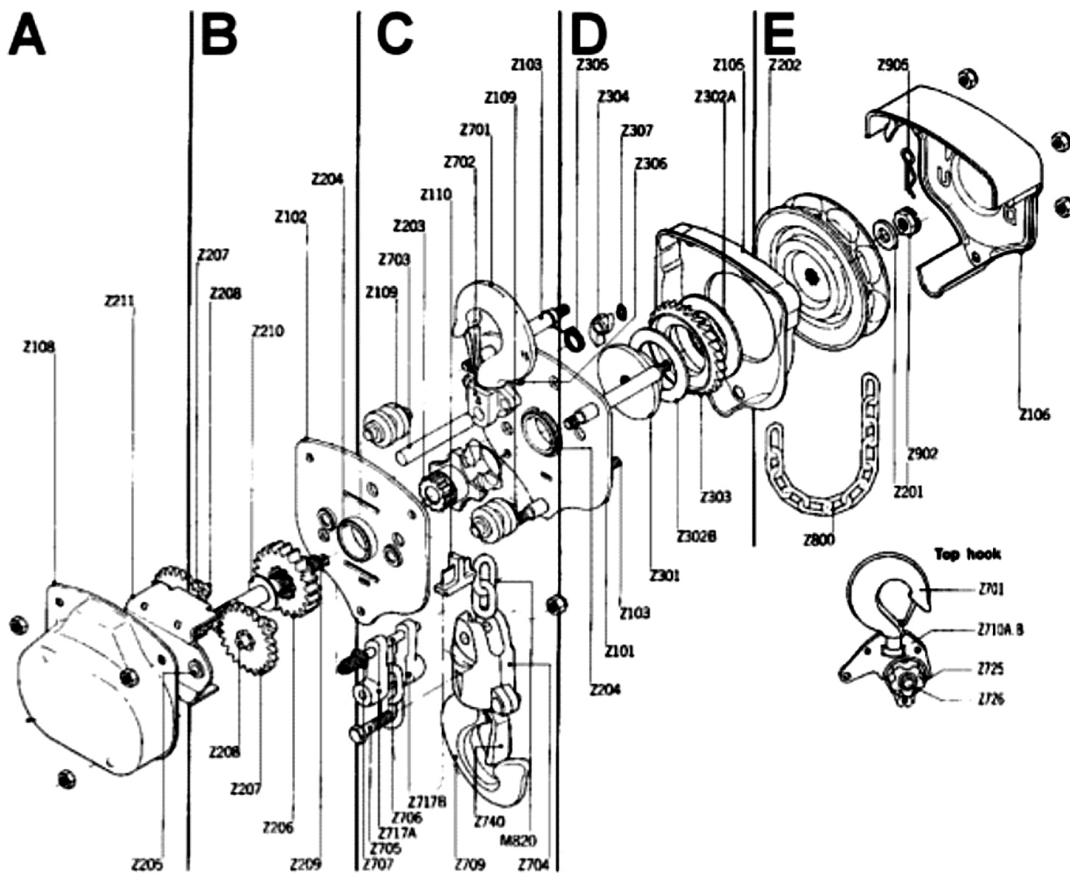

Parts no.	Quantity	Description
Z108	1	Gear Cover
<b>A</b> Z205	4	Gear Bushing
Z211	1	Support plate
<b>I</b> Z102	1	Side plate(II)
Z204	1	Bush
Z206	1	1st Gear
<b>B</b> Z207	2	2st Gear
Z208	2	3rd Gear
<b>I</b> Z209	1	Pinion Shaft
Z210	1	Pinion Washer
Z109	2	Load Chain Guide
Z110	1	Chain Stripper
Z203	1	Load Sheave
Z701 - 702	1	Top Hook
Z709 - 704	1	Bottom Hook(VH)
Z701 - 704	1	Bottom Hook(VL)
<b>C</b> Z740	1	Safety Latch
Z703	1	Hook Pin
<b>I</b> Z705	1	Bolt and Nut for Load Chain
Z706	1	End Pin
Z717A - B	1	End anchor
Z707	1	End Spring
M820	1	Load Chain(VL)
H820	1	Load Chain(VH)
<b>D</b> Z101	1	Side Plate (I)
Z103	3	Stay Bolt

Parts no.	Quantity	Description
Z105	1	Brake Cover
Z204	1	Bush
Z301	1	Hub
<b>D</b> Z302A	1	Brake Disc A
Z302B	1	Brake Disc B
Z303	1	Ratchet Gear
Z304	1	Pawl
Z305	1	Spring
Z306	1	Pawl Stud
Z106	1	Wheel Cover
Z201	1	Hand Wheel Washer
<b>E</b> Z202	1	Hand Wheel
Z800	1	Hand Chain
Z902	1	Pinion Nut
Z905	1	Cotter Pin
Z701	1	Top Hook
Z710A - B	2	Top Frame
Z709	1	Bottom Hook
Z718		C-Link
<b>F</b> Z719	2	O-Link
Z713	1	Thrust Washer
Z721(L)	1	Bottom Frame
Z721(H)	2	Bottom Frame
Z725	2	Sheave
Z726		Axle

# Service Notes

---

---

---

---

---

---

---

---

---

---

---

---

---

---

---

---

---

---

---

---

---

---

---



P.O. Box 845, Winona, MN 55987  
Phone (800) 749-1064  
(507) 474-6250  
Tech Support (507) 457-3346  
Fax (507) 452-5217  
sales@ozliftingproducts.com  
[www.ozliftingproducts.com](http://www.ozliftingproducts.com)

Rev. 11/29/12