

Ion 510[™] & Ion 520[™] & Ion 530[™] Kit – Chef USER GUIDE

Instructions for automated template preparation, chip loading, and sequencing

for use with:

Ion Chef[™] System

Ion S5[™] System

Ion S5[™] XL System

Ion GeneStudio[™] S5 System

Ion GeneStudio[™] S5 Plus System

Ion GeneStudio[™] S5 Prime System

Catalog Numbers A34461, A34019

Publication Number MAN0016854

Revision F.0



The information in this guide is subject to change without notice.

DISCLAIMER: TO THE EXTENT ALLOWED BY LAW, THERMO FISHER SCIENTIFIC INC. AND/OR ITS AFFILIATE(S) WILL NOT BE LIABLE FOR SPECIAL, INCIDENTAL, INDIRECT, PUNITIVE, MULTIPLE, OR CONSEQUENTIAL DAMAGES IN CONNECTION WITH OR ARISING FROM THIS DOCUMENT, INCLUDING YOUR USE OF IT.

Revision history: Pub. No. MAN0016854

Revision	Date	Description
F.0	29 October 2020	<ul style="list-style-type: none"> • Included chip compatibility information in “Ion S5™ Calibration Standard” on page 10. • Added new troubleshooting items: “Chip Check fails” on page 67 and “Reagent Check fails” on page 67. • Updated requirement for Ion AmpliSeq™ panels with amplicons greater than 325 bp. • Added recommendation for chips used for initialization. • Updated run time information.
E.0	25 June 2019	<ul style="list-style-type: none"> • Updated for Torrent Suite™ Software 5.12. • Updated “Start the Ion Chef™ run” to include the Run Options screen for step-by-step Ion Chef™ run setup. • Updated the guidance for storing loaded chips before sequencing in “Unload the chips for sequencing”. • Added a note in “Start the Ion Chef™ run” and “Unload the chips for sequencing” to NOT remove any residual liquid from chip wells after the Ion Chef™ run. • Added a note regarding templated ISP range specification in “Ion Sphere™ Assay troubleshooting table”. • Removed Ion Chef™ System maintenance procedures from “Maintain the Ion Chef™ System”. • Updated “Maintain the Ion Chef™ System” to add references to the Ion Chef™ System maintenance procedures in <i>Ion Chef™ Instrument User Guide</i>. • Updated “Related documentation” to include the <i>Ion Chef™ Instrument User Guide</i>.
D.0	05 December 2018	<ul style="list-style-type: none"> • Updated for Ion GeneStudio™ S5 Systems. • Clarification made to dilute barcoded library pools, if used. • Updated for the Qubit™ 4 Fluorometer. • References to ISP quality control user guides updated to the <i>Ion Sphere™ Quality Control Kit User Guide</i> (Pub. No. MAN0017531). • Added a new troubleshooting topic: “Planned Run status does not advance to “Planned””. • Updated for Torrent Suite™ Software 5.10; Planned Run creation topics reorganized for ease of use. • Ion S5™ Controls Kit replaced with Ion S5™ Controls Kit Plus. • Removed reference to quality control of ISPs using the Attune™ NxT Acoustic Focusing Cytometer.

Important Licensing Information: These products may be covered by one or more Limited Use Label Licenses. By use of these products, you accept the terms and conditions of all applicable Limited Use Label Licenses.

Trademarks: All trademarks are the property of Thermo Fisher Scientific and its subsidiaries unless otherwise specified. Guava is a trademark of Merck KGaA. Agencourt and Ampure are trademarks of Beckman Coulter, Inc. Bioanalyzer is a trademark of Agilent Technologies, Inc. Axygen™ and MAXYMum Recovery™ are trademarks of Corning, Inc.

Contents

■	CHAPTER 1	Product information	7
		Product description	7
		Library compatibility	7
		Mixing chip types	7
		Sequencer compatibility	8
		Software compatibility	8
		Kit contents and storage	8
		Kit summary	9
		Ion Chef™ reagents and materials	9
		Ion S5™ sequencing reagents and materials	9
		Related products	10
		Compatible Ion Chip™ kits	10
		Ion S5™ Calibration Standard	10
		Ion S5™ Controls Kit Plus	10
		Required materials not supplied	11
		About the Ion Chef™ System	12
		Ion Chef™ Instrument components	12
		Interior hardware and consumables	13
		About the Ion Chef™ System touchscreen interface	14
		Workflow	15
■	CHAPTER 2	Before you begin	16
		Precautions	16
		Avoid nucleic acid contamination	16
		Avoid chip damage	16
		Protection by equipment	16
		Guidelines for using Ion Chef™ reagents and consumables	16
		Prepare the Ion Chef™ Instrument for use	17
■	CHAPTER 3	Create a Planned Run	18
		About Planned Runs	18
		Create a Planned Run	19
		Planned Run workflow key fields	23

■	CHAPTER 4	Start the Ion Chef™ run	25
		Materials required	25
		Dilute the libraries	25
		Guidelines for library dilution	26
		Dilute the sample libraries	26
		Dilute the control library (if used)	27
		Prepare the consumables	27
		Add the diluted libraries to the Ion Chef™ Library Sample Tube	28
		Load the Ion Chef™ System	28
		Load the pipette tip racks and PCR Plate	29
		Load the Reagents and Solutions cartridges	31
		Load the Recovery Tubes and Enrichment Cartridge v2	33
		Load the Chip-loading centrifuge	34
		Confirm that consumables are correctly installed	36
		Single chip loading workflow	37
		Ion Chef™ pre-run checklist	39
		Start the Ion Chef™ run	40
		Unload the chips for sequencing	45
■	CHAPTER 5	Initialize the sequencer	48
		Ion S5™ /Ion GeneStudio™ S5 Systems component positions	48
		Before you begin	49
		When a manual cleaning of the sequencer is required	49
		Initialize the sequencer	50
■	CHAPTER 6	Start the sequencing run	52
		Place chip in chip clamp	52
		Start the sequencing run	53
		Maintain the sequencer	55
		Materials required	55
		Clean or decontaminate the sequencer	55
		Reagent consumables disposal	55
		CO ₂ scrubber removal and disposal	55
		Recycle Ion S5™ Wash Solution and Ion S5™ Cleaning Solution bottles	56

■	CHAPTER 7	Clean the Ion Chef™ System	57
		About the cleaning protocol	57
		Materials required	57
		Clean the Ion Chef™ Instrument	57
		Remove and dispose of used consumables	58
		Inspect and clean the Recovery centrifuges and buckets	59
		Start the cleaning	61
■	APPENDIX A	Troubleshooting	63
		View troubleshooting and FAQs online	63
		Ion Chef™ System setup and operation	63
		Ion S5™ /Ion GeneStudio™ S5 Systems setup and operation	66
		Instrument alarms and events	66
		Initialization—General errors	67
		Ion Sphere™ Assay troubleshooting table	69
■	APPENDIX B	Supplemental procedures	70
		Perform a manual cleaning of the sequencer	70
		Perform an instrument reset run with an initialized sequencer that is loaded with an unused Reagents cartridge	71
		Quality control of Ion 510™ ISPs, Ion 520™ ISPs, or Ion 530™ ISPs	73
		Quality control using the Ion Sphere™ Assay on the Qubit™ Fluorometer	73
		Acceptance criteria for unenriched Ion 510™ ISPs, Ion 520™ ISPs, or Ion 530™ ISPs	73
		Quality control using the Guava™ easyCyte 5 Benchtop Flow Cytometer	73
		Maintain the Ion Chef™ System	75
■	APPENDIX C	Safety	76
		Symbols on this instrument	76
		Conformity symbols	77
		Location of safety labels on this instrument	78
		Safety information for instruments not manufactured by Thermo Fisher Scientific	78
		Instrument safety	78
		General	78
		Physical injury	78
		Electrical safety	79
		Cleaning and decontamination	79
		Ultraviolet (UV) Safety	79

Safety and electromagnetic compatibility (EMC) standards	79
Safety compliance	80
EMC	80
Environmental design	80
Instrument safety — Ion S5™ /Ion GeneStudio™ S5 Systems	81
Chemical safety	81
Biological hazard safety	82
Documentation and support	83
Related documentation	83
Customer and technical support	83
Limited product warranty	83



Product information

■ Product description	7
■ Kit contents and storage	8
■ Related products	10
■ Required materials not supplied	11
■ About the Ion Chef™ System	12
■ Workflow	15

IMPORTANT! Before using this product, read and understand the information in the “Safety” appendix in this document.

Product description

The Ion 510™ & Ion 520™ & Ion 530™ Kit – Chef (Cat. Nos. [A34461](#), [A34019](#)) is used for automated template preparation and sequencing of 400 base-read Next Generation sequencing libraries using the Ion Chef™ System and the Ion S5™ System, Ion S5™ XL System, or Ion GeneStudio™ S5 System. The kit contains prepackaged single-use template and sequencing reagent cartridges with integrated sample tracking.

Key features of the kit include:

- Automated workflow for sequencing of 8 loaded chips with complete run traceability.
- Maximum flexibility with compatibility for the Ion 510™ Chip, Ion 520™ Chip, and Ion 530™ Chip.

Library compatibility

The Ion 510™ & Ion 520™ & Ion 530™ Kit – Chef can be used with up to 400-base-read libraries of any type prepared using any available Ion Torrent™-branded library kit.

Mixing chip types

You can perform templating runs with two different types of chips, using any combination of the three chips. However, you cannot mix template sizes (200-base and 400-base template run lengths) in a single run.

IMPORTANT! To perform templating runs with mixed chip types, you must update the Torrent Suite™ Software to version 5.6 or later (see “Software compatibility”).

Sequencer compatibility

Ion GeneStudio™ S5 Series Sequencer or Ion GeneStudio™ S5 Series System refers generically to following systems, unless otherwise specified.

- Ion GeneStudio™ S5 System (Cat. No. [A38194](#))
- Ion GeneStudio™ S5 Plus System (Cat. No. [A38195](#))
- Ion GeneStudio™ S5 Prime System (Cat. No. [A38196](#))

Software compatibility

The Ion 510™ & Ion 520™ & Ion 530™ Kit – Chef is compatible with Torrent Suite™ Software 5.4 and later. Be sure to update your Torrent Suite™ Software to the latest available version before using this kit. For more information, see the *Torrent Suite™ Software User Guide* for your version of the software.

Kit contents and storage

IMPORTANT!

- Do not substitute components from any other sequencing kits. We have verified this protocol using these specific materials. Substitution can adversely affect system performance.
 - Store all consumables and cartridges under the recommended conditions and in an upright position. Do NOT store the Ion S5™ Sequencing Reagents (Part No. A27768) on dry ice or in a closed environment where dry ice is present.
-

Each Ion 510™ & Ion 520™ & Ion 530™ Kit – Chef contains all the supplies that are required to prepare and sequence 8 Ion 510™ Chips, Ion 520™ Chips, or Ion 530™ Chips.

- Catalog No. [A34461](#) supports 4 Ion Chef™ runs (2 chips/Ion Chef™ run) and 4 sequencer initializations (2 sequencing run/sequencer initialization). Select [A34461](#) for templating and sequencing of 200-base-read libraries only.
- Catalog No. [A34019](#) supports 4 Ion Chef™ runs (2 chips/Ion Chef™ run) and 8 sequencer initializations (1 sequencing run/sequencer initialization). Select [A34019](#) for templating and sequencing of 400-base-read libraries.

On arrival, inspect all consumables and contact Technical Support if any of the products have been damaged during shipping.

Kit summary

Component	Part No.	Quantity per kit	
		A34461	A34019
Ion S5™ Chef Supplies	A27755	4 boxes	4 boxes
Ion S5™ Chef Solutions	A27754	1 box	1 box
Ion 510™ & Ion 520™ & Ion 530™ Chef Reagents	A34018	1 box	1 box
Ion S5™ Sequencing Solutions	A27767	1 box	2 boxes
Ion S5™ Sequencing Reagents	A27768	1 box	2 boxes

Ion Chef™ reagents and materials

Contents	Amount / box	Storage
Ion S5™ Chef Supplies (Part No. A27755)		
Chip Adapter	2	15°C to 30°C
Enrichment Cartridge v2	1	
Tip Cartridge v2	1	
PCR Plate	1	
Frame Seal v2	1	
Recovery Station Disposable Lid v2	2	
Recovery Tube v2	12	
Ion S5™ Chef Solutions (Part No. A27754)		
Ion S5™ Chef Solutions	4 cartridges	15°C to 30°C
Ion 510™ & Ion 520™ & Ion 530™ Chef Reagents (Part No. A34018)		
Ion 510™ & Ion 520™ & Ion 530™ Chef Reagents	4 cartridges	-30°C to -10°C

Ion S5™ sequencing reagents and materials

Contents	Amount / box	Storage
Ion S5™ Sequencing Solutions (Part No. A27767)		
Ion S5™ Wash Solution	4 × 1.5 L	15°C to 30°C
Ion S5™ Cleaning Solution	250 mL	

Contents	Amount / box	Storage
Ion S5™ Sequencing Reagents (Part No. A27768)		
Ion S5™ Sequencing Reagents	4 cartridges	-30°C to -10°C ^[1]

^[1] Cartridges ship at 2°C to 8°C. Store as indicated, do not store on dry ice.

IMPORTANT! Do not store the Ion S5™ Sequencing Reagents (Part No. A27768) on dry ice or in a closed environment containing dry ice.

Related products

Compatible Ion Chip™ kits

Description	Catalog No.	Quantity	Storage
Ion 510™ Chip Kit (2 × 4-pack)	A34292	8 chips	15°C to 30°C
Ion 520™ Chip Kit (2 × 4-pack)	A27762	8 chips	
Ion 530™ Chip Kit (2 × 4-pack)	A27764	8 chips	

Ion S5™ Calibration Standard

For *de novo* sequencing applications, the Ion S5™ Calibration Standard can be added to diluted libraries to increase base-calling accuracy. The Ion S5™ Calibration Standard (Cat. No. A27988) is ordered separately.

Use the Ion S5™ Calibration Standard with Ion 520™ Chip or Ion 530™ Chip workflows only. The standard has not been validated for use with the Ion 510™ Chip workflow.

Contents	Amount	Storage
Ion S5™ Calibration Standard	80 µL	-30°C to -10°C

Ion S5™ Controls Kit Plus

The Ion S5™ Controls Kit Plus (Cat. No. [A30729](#)) is ordered separately. See the *Ion S5™ Controls Kit Plus Product Information Sheet* (Pub. No. MAN0016206) for details.

Contents	Amount	Storage
Human CEPH Genomic DNA Control (red cap)	30 µL	-30°C to -10°C
Human CEPH Control 200 Library (yellow cap)	12 µL	
<i>E. coli</i> DH10B Control 400 Library (orange cap)	16 µL	

Required materials not supplied

Unless otherwise indicated, all materials are available through [thermofisher.com](https://www.thermofisher.com). "MLS" indicates that the material is available from [fisherscientific.com](https://www.fisherscientific.com) or another major laboratory supplier.

Item	Source
Ion Chef™ System	4484177
Microcentrifuge ^[1]	MLS
2-, 20-, 200-, and 1,000- μ L pipettes and appropriate filtered tips	MLS
Microcentrifuge tubes, 1.5-mL or 1.7-mL	MLS
Vortex mixer with a rubber platform	MLS
Gloves, powder-free nitrile	MLS
Ice buckets and ice	—
Nuclease-free water, molecular biology grade	MLS
Isopropyl alcohol, 70% solution	MLS
Wipes, disposable lint-free	MLS
(Optional) Uninterruptible Power Supply (UPS) ^[2]	MLS

^[1] Must fit standard 0.2- and 1.5-mL microcentrifuge tubes and generate 21,000 \times g. To convert the RPMs of your centrifuge to RCF in units of gravity, see tools.thermofisher.com/content/sfs/brochures/TR0040-Centrifuge-speed.pdf.

^[2] For laboratories that experience frequent power outages or line voltage fluctuations, we recommend that you use an uninterruptible power supply that is compatible with 2500 W output or higher.

About the Ion Chef™ System

The Ion Chef™ System (Cat. No. 4484177) provides automated, high-throughput template preparation and chip loading for use with an Ion S5™ Sequencer, Ion S5™ XL Sequencer, or Ion GeneStudio™ S5 Series Sequencer. The system includes a complete set of cartridge-based consumables and reagents that enable a user to load two chips in approximately 13 hours with less than 15 minutes of hands-on time. The Ion Chef™ System features network integration with the Torrent Suite™ Software to enable sample and reagent traceability throughout the chip preparation workflow.

Ion Chef™ Instrument components

The following figure illustrates the major external and internal features of the Ion Chef™ Instrument.

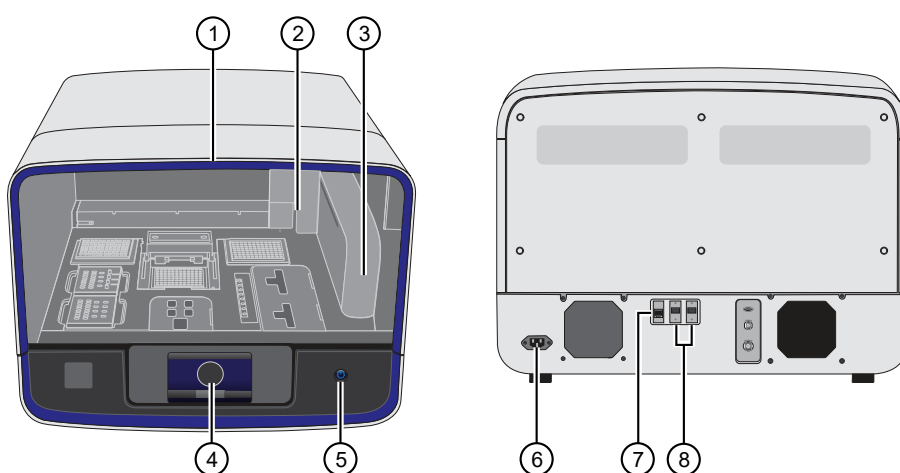

- ① **Door** – Provides access to the interior of the instrument. The door is locked in the closed position during operation.
- ② **Micropipettor** – A mechanical positive-displacement pipettor that performs all fluid transfers during sample and chip preparation.
- ③ **Robotic arm** – Enables fluid transfer by the Micropipettor. The arm also contains an optical sensor that reads the barcodes of instrument reagents and consumables.
- ④ **Touchscreen** – Provides access to all instrument functions for operation, maintenance, and troubleshooting.
- ⑤ **Power button** – Power switch for the Ion Chef™ Instrument, where the states are on (illuminated) and off.
- ⑥ **Power port** – A 100–240 VAC port that provides power to the Ion Chef™ Instrument.
- ⑦ **Ethernet port** – An RJ45 port that provides Ethernet (100 Mbit) communication with the Ion Chef™ Instrument.
- ⑧ **USB port** – Provides USB communication with the Ion Chef™ Instrument. Used to update the instrument firmware and to transfer data during service or maintenance.

Interior hardware and consumables

The following figure illustrates the interior of the Ion Chef™ Instrument and describes the stations involved in the preparation of chips for sequencing on an Ion S5™ Sequencer, Ion S5™ XL Sequencer, or Ion GeneStudio™ S5 Series Sequencer.

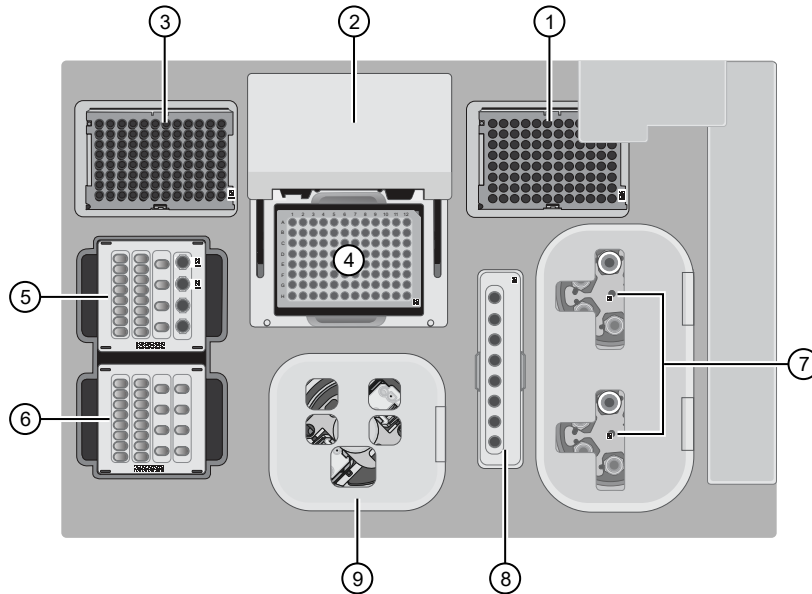

- ① **Waste pipette tip rack** – The position of the rack containing waste (used) pipette tips.
- ② **Automated heated cover** – Transfers the plate cover to the PCR reaction plate within the sample block. During thermal cycling, the heated cover applies compression to seal the reaction plate and heats the cover to prevent condensation.
- ③ **New pipette tips** – The position of the rack containing unused pipette tips.
- ④ **Thermal cycler sample block** – Performs thermal cycling of the sequencing reactions on a 96-well PCR reaction plate.
- ⑤ **Reagents station** – The position on the instrument deck of the diluted libraries, NaOH, and the Ion 510™ & Ion 520™ & Ion 530™ Chef Reagents cartridge.
- ⑥ **Solutions station** – The position on the instrument deck of the Ion S5™ Chef Solutions cartridge, which is maintained at room temperature.
- ⑦ **Recovery centrifuges** – Twin stations that perform centrifugation of the ISPs during the recovery phase of template preparation.
- ⑧ **Enrichment station** – The position of the rack containing consumables for enrichment of the template-positive ISPs.
- ⑨ **Chip-loading centrifuge** – Performs centrifugation of sequencing chips that have been mounted to chip-loading adapters and loaded with template-positive ISPs.

About the Ion Chef™ System touchscreen interface

The Ion Chef™ System features a simple interface for loading chips, cleaning the instrument, and performing system maintenance and configuration tasks.



- ① **Set up run** button – Set up the Ion Chef™ template preparation and chip-loading routine. Choose **Step by Step** to have the instrument lead you stepwise through installation of reagents and consumables, or choose **Quick Start** to proceed if you have already installed the consumables.
- ② **Open Door** button.
- ③ **Notifications** button – View notifications about instrument status during and between runs.
- ④ **Quick Start** button – Proceed directly to the Quick Start instrument setup mode. User verifies the loading of a new pipette tip cartridge and an empty pipette tip rack to hold waste tips generated during the run, before proceeding to Deck Scan.
- ⑤ **Settings** button – Advance to a screen providing the following options:
 - **Notifications:** view notifications about instrument status during and between runs
 - **Instrument Settings:** view current settings and network configuration, set instrument name, adjust time zone
 - **Service tools:** access screens for service-related maintenance and instrument diagnostics
 - **Torrent Server:** add and manage Ion Torrent™ Server connections
 - **Clean Ion Chef:** proceed directly to the instrument cleaning routine
 - **Check for updates:** check availability of system software updates

Workflow

The following workflow shows how to prepare and load samples using the Ion 510™ & Ion 520™ & Ion 530™ Kit – Chef and Ion Chef™ System for sequencing on an Ion S5™ Sequencer, Ion S5™ XL Sequencer, or Ion GeneStudio™ S5 Series Sequencer.

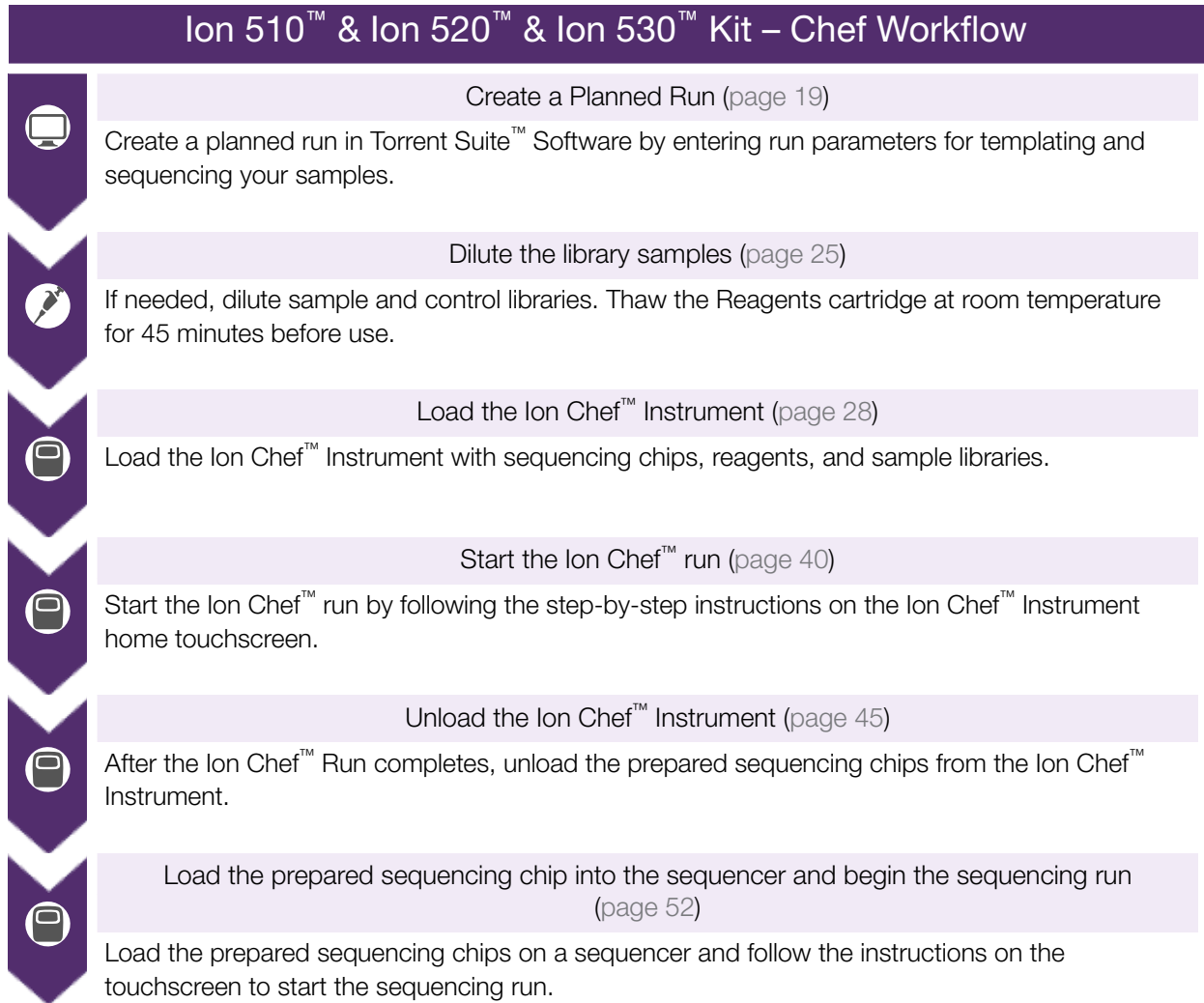

2

Before you begin

- Precautions 16
- Guidelines for using Ion Chef™ reagents and consumables 16
- Prepare the Ion Chef™ Instrument for use 17

Precautions

Avoid nucleic acid contamination

IMPORTANT! A primary source of contamination is spurious DNA fragments from previous sample processing steps. Do not introduce amplified DNA into the library preparation laboratory or work area.

Avoid chip damage

IMPORTANT! To avoid possible damage to the chip due to electrostatic discharge, ground yourself before picking up a chip or placing a chip on a surface such as a lab bench. For example, touch the metal trim on the chip compartment before inserting or removing a chip from the chip clamp.

Protection by equipment



WARNING! The protection that is provided by the equipment can be impaired if the instrument is operated outside the environment and use specifications, the user provides inadequate maintenance, or the equipment is used in a manner that is not specified by the manufacturer (Thermo Fisher Scientific).

Guidelines for using Ion Chef™ reagents and consumables

- Store all consumables and cartridges under the recommended conditions and in an upright position.
- Inspect all consumables and cartridges for damage on arrival and again before use.
- Hold sequencing chips by gently gripping them by their edges.
- When the instrument is not in use, remove all consumables and reagents from the deck and close the instrument door.

- Except for the *new* Tip Cartridge v2, do not reuse any of the consumables or reagents. After each run, the empty Tip Cartridge v2 is transferred to the waste tip station.

IMPORTANT! All components are single-use only.

- Use only Ion Torrent™ kits and supplies with the Ion Chef™ Instrument. The use of third-party reagents and supplies can adversely affect the performance of the instrument and chips.
- Remove and sequence chips within 1 hour after the instrument finishes loading them. If you cannot sequence a loaded chip immediately, store it in a chip storage container at 4°C until you are ready to run it (up to 6–8 hours maximum).

IMPORTANT! If you choose to store a loaded chip, remove the chip from 4°C storage (but keep it in the chip storage container) at least 20 minutes before running it, allowing the chip to warm to room temperature.

Prepare the Ion Chef™ Instrument for use

- Ensure that the Ion Chef™ Instrument has been cleaned following the previous run. If not, clean the instrument *before* loading it with consumables.

Note: For more information on the cleaning procedure, see Chapter 7, “Clean the Ion Chef™ System”.

- Inspect the empty compartments of the Reagents and Solutions stations for condensation. Condensate can collect in these compartments, depending on temperature and humidity conditions. Before loading consumables into the instrument, wipe the compartments dry with a laboratory wipe or absorbent cloth, if needed.
- Thaw the Ion 510™ & Ion 520™ & Ion 530™ Chef Reagents cartridge at room temperature for 45 minutes before use.
- Ensure that the Ion Chef™ Instrument has a connection to the Ion Torrent™ Server. On the instrument home touchscreen, tap **Settings ▶ Ion Torrent™ Server** to view the connection status.

Note: If the instrument is not connected, see the *Ion Chef™ Instrument Network Connection User Guide* (Pub. No. MAN0013444) for instructions on how to configure a direct or indirect network connection.



Create a Planned Run

- About Planned Runs 18
- Create a Planned Run 19
- Planned Run workflow key fields 23

About Planned Runs

Planned Runs are digital instructions that are created in Torrent Suite™ Software for controlling the template preparation and sequencing instruments. Planned Runs contain settings such as number of flows, kit types, barcodes, sample information, and reference files (if any). Planned Runs are also used to track samples, chips, and reagents throughout the workflow, from template preparation on the Ion Chef™ Instrument through sequencing on an Ion S5™ Sequencer, Ion S5™ XL Sequencer, or Ion GeneStudio™ S5 Series Sequencer and subsequent data analysis. Each chip that is prepared in an Ion Chef™ run requires its own Planned Run.

IMPORTANT! For more information on creating a Planned Run in Torrent Suite™ Software, including a complete description of each field in the **Create Plan** workflow bar, see the *Torrent Suite™ Software Help*, available by clicking the **Help** button in the software.

Create a Planned Run

IMPORTANT! If you are using the Ion 510™ & Ion 520™ & Ion 530™ Kit – Chef with libraries that were prepared using OncoPrint™ panels, see the corresponding OncoPrint™ Assay User Guide for assay-specific instructions on creating a Planned Run in Torrent Suite™ Software.

1. Sign in to the Torrent Suite™ Software.
2. In the **Plan** tab, in the **Templates** screen, select the application that you want to run (such as AmpliSeq DNA) from the left navigation menu, then click one of the following options:
 - To plan a new run using the **Generic Sequencing** template for the selected application, click **Plan New Run**.
 - To plan a new run using a specific Planned Run template, in the row of the template, click **⚙️ (Actions) ▶ Plan Run**.

The screenshot shows the 'Plan' tab in the Torrent Suite software. The left navigation menu is open, showing 'AmpliSeq DNA' selected. The main area displays a list of templates for 'AmpliSeq DNA'. The 'Plan New Run' button is highlighted in red. A dropdown menu is open for the 'Oncomine Focus DNA for S5' template, with the 'Plan Run' option highlighted in red.

Template Name	Instr	Sam... Prep	R... App	Barcodes	Reference	Project	Ion Reporter Account	Ion Reporter Workflow	Date	Source
Oncomine Focus DNA for S5				IonXpress	hg19				May 27 2018	ion torrent
Oncomine BRCA Research for S5				IonXpress	hg19					
Oncomine Comprehensive v3 DNA for 550				IonXpress	hg19					
Oncomine Comprehensive v3 DNA				IonXpress	hg19					
Oncomine Childhood Cancer Research DNA				IonXpress	hg19				Jan 20 2018	ion torrent

3. In the **Create Plan** workflow bar, review the **Ion Reporter** and **Research Application** steps, then make selections appropriate to your run. Click **Next**.
4. In the **Kits** step, make the following selections:
 - a. Select **Ion GeneStudio™ S5 System** from the **Instrument** dropdown list.
 - b. Select the appropriate chip type from the **Chip Type** dropdown list.
 - c. Select the library kit used to prepare your libraries from the **Library Kit Type** dropdown list.
 - d. (Optional) For barcoded libraries, select the barcode set used during library preparation from the **Barcode Set** dropdown list.

- e. Select **IonChef** for **Template Kit**, then select **Ion 510™ & Ion 520™ & Ion 530™ Kit – Chef** from the **Template Kit** dropdown list.
- f. Select **Ion S5 Sequencing Kit** from the **Sequencing Kit** dropdown list.
- g. Enter the appropriate number of flows in the **Flows** field.

Sequencing type	Number of flows
200-base-read	500
400-base-read	850

Note:

- If you are using Ion AmpliSeq™ On-Demand panels, set the flows to 550. Due to the recommended flows setting of 550, **you cannot perform more than one sequencing run per initialization.**
- If you are using Ion AmpliSeq™ panels with amplicons longer than 325 bp, increase the number of flows to 650. A file with information about amplicon length can be downloaded from AmpliSeq.com. See the *Ion AmpliSeq™ Designer Help* (Pub. No. MAN0018937).

IMPORTANT! Do not exceed 1,200 total flows for one Ion S5™ Sequencing Reagents cartridge. For 200-base-read sequencing, you can run two chips per sequencer initialization. For 400-base-read sequencing, you can run only one chip per sequencer initialization.

- h. In the **Advanced Settings** pane, select **Customize**, then select the templating protocol from the **Templating Protocol** dropdown list.

Note:

- Select **Chef Protocol - 200** for libraries with <300-base average read length.
- Select **Chef Protocol - 400** for libraries with ≥300-base average read length.
- For Ion AmpliSeq™ On-Demand panels, ensure that **Chef Protocol - 200** is selected.

- i. Select or edit the remaining optional information fields appropriately for your run.

IMPORTANT! For *de novo* sequencing applications that do not include a reference BAM file, select **Enable Calibration Standard** from the **Base Calibration Mode** dropdown list in the **Advanced Settings** pane. Select this option only if you are adding Ion S5™ Calibration Standard to the Ion Chef™ Library Sample Tubes. Selecting this option and adding the Ion S5™ Calibration Standard to your library allows greater accuracy of base-calling in libraries for which a reference BAM file does not exist.

j. Click **Next**.

Select instrument, chip and kits and then hit next.

Instrument :
Ion GeneStudio S5 System

Sample Preparation Kit (optional) :
[Dropdown]

Library Kit Type :
[Dropdown]

Template Kit OneTouch IonChef IA :
Ion 510 & Ion 520 & Ion 530 Kit-Chef

Templating Size ⓘ
Sequencing Kit :
Ion S5 Sequencing Kit

Chip Type :
Ion 530™ Chip

Control Sequence (optional) :
[Dropdown]

Barcode Set (optional) :
[Dropdown]

Flows :
500

Mark as Duplicates Reads :
 Enable Realignment :

Advanced Settings

Use Recommended Defaults Customize

Warning! It's not recommended to change these settings, please consult your local field representative before modifying parameters below.

Templating Protocol :
Chef Protocol - 200 bp

Base Calibration Mode :
Default Calibration

Summary

Research Application: DNA
Research Category: Oncology - Solid Tumor
Target Technique: AmpliSeq DNA
Ion Reporter: None
Sample Grouping:
Instrument: Ion GeneStudio S5 System
Chip Type: Ion 530™ Chip
Sample Preparation Kit:
Control Sequence:
Library Kit Type:
Barcode Set:
Template Kit: Ion 510 & Ion 520 & Ion 530 Kit-Chef
Sequencing Kit: Ion S5 Sequencing Kit
Library Read Length: --
Flows: 500
Mark as Duplicate Reads: False
Enable Realignment: False

5. Review the **Plugins** and **Projects** steps, then make selections appropriate to your run.

6. In the **Plan** step, enter or make the following selections:

- a. Enter a Run Plan Name, then select Reference and BED files appropriate to your run.
- b. Enter the number of barcodes you are using in your combined library in the **Number of barcodes** field, then click to the right of this field. Edit the auto-populated list of barcodes that appears, if needed.

Note: If you did not use barcode adapters in library preparation and did not select a **Barcode Set** in the **Kits** step, fields appear in the **Plan** step where you enter the number of chips that are used, then enter the sample name and chip barcode for each sample.

- c. Scan or enter the barcode of the Ion Chef™ Library Sample Tube into the **Sample Tube Label** field.
- d. Scan or enter the chip barcode into the **Chip Barcode** field.

- e. Enter a sample name for each barcode in the appropriate **Sample Name (required)** fields.

Create Plan
Ion Reporter
Research Application
Kits
Plugins
Projects
Plan

Template Name : Show Summary

Oncomine Focus DNA

Run Plan Name (required) :

Oncomine Focus DNA for S5 1

Analysis Parameters: Default (Recommended) Custom Details +

Default Reference & BED Files -

Reference Library: hg19(Homo sapiens)

Target Regions: Oncomine_Focus.20150415.designed.forIR.bed

Hotspot Regions: Oncomine_Focus.20150709.hotspots.bed

Use same reference & BED files for all barcodes

Number of barcodes : 8 ✔ Save Samples Table Load Samples Table

Sample Tube Label :

Chip Barcode :

Enter a sample name for each barcode used (require at least one sample) ↓ 🗑 :

#	Barcode	Sample Name (required)	Control Type	Sample ID	Sample Description	Reference
1	IonCode_0101 (CTAAGGTAAC)	Sample 1				
2	IonCode_0102 (TAAGGAGAAC)	Sample 2				
3	IonCode_0103 (AAGAGGATTC)	Sample 3				

7. After you have completed your selections, click **Plan Run** at the bottom right of the **Plan** step screen to save the run.

The run is listed in the **Planned Runs** screen under the name that you specified and is automatically used by the Ion Chef™ System when the associated sample is loaded.

If you are performing a dual-chip run, repeat step 2–step 7 to create a Planned Run for the second chip. You can copy the first Planned Run in the Planned Runs screen, then edit as needed.

Planned Run workflow key fields

Step or field name	Description
Ion Reporter	If the Ion Reporter™ Software is installed and enabled, and you want to analyze the run data using the software, select the Ion Reporter Account , then select the Ion Reporter™ workflow from the Existing Workflow dropdown list.
Research Application	Select the Research Application and Target Technique that represent your sequencing experiment.
Instrument	Select Ion GeneStudio™ S5 System .
Chip Type	Select the Ion 510™ Chip , Ion 520™ Chip , or Ion 530™ Chip .
Library Kit Type	Select the kit used to prepare the library.
Template Kit	Select Ion 510™ & Ion 520™ & Ion 530™ Kit – Chef .
Sequencing Kit	Select Ion S5 Sequencing Kit .
Barcode Set (optional)	<p>If you are using barcodes with:</p> <ul style="list-style-type: none"> • DNA libraries – Select the appropriate barcode set used. • RNA libraries prepared using the Ion Total RNA-Seq Kit v2 – Select the IonXpressRNA barcode set, which contains all 16 barcodes in the Ion Xpress™ RNA-Seq Barcode 1–16 Kit. <p>If you are <i>not</i> using barcodes with:</p> <ul style="list-style-type: none"> • DNA libraries – Leave the Barcode Set field blank. • RNA libraries prepared using the Ion Total RNA-Seq Kit v2 – Select RNA_Barcode_None from the dropdown list. This will ensure that the proper trimming is performed on the resulting sequence when the RNA library does not have a barcode.
Flows	Enter the appropriate number of flows for the read length (for example, 500 flows for 200-base-read sequencing and 850 flows for 400-base-read sequencing).
Plugins	Select the appropriate plugins for your application.
Projects	Select or add a project to group your run data. You can include runs in multiple projects, and remove runs from a project at any time.
Run Plan Name	Enter a name for the run.
Reference Library	Select a reference library uploaded to the Torrent Suite™ Software, if any.
BED files	Select the Target Regions or HotSpot Regions BED file in the Torrent Suite™ Software, if any.

(continued)

Step or field name	Description
Sample Tube Label (Required)	<p>Enter or scan the barcode of the Ion Chef™ Library Sample Tube that you will use to load your sample into the Ion Chef™ Instrument.</p> <p>IMPORTANT! Each chip that is prepared in an Ion Chef™ run requires its own Planned Run. You must scan or enter the barcode of the appropriate Ion Chef™ Library Sample Tube for each Planned Run that is created for each individual chip.</p>
Chip Barcode	Enter or scan the chip barcode.
Sample Name (Required)	<p>Did you select a Barcode Set in the Kits step?</p> <ul style="list-style-type: none"> • No – Enter the sample name for each sample loaded onto each chip in the Sample Name (required) column, then enter or scan the corresponding Ion Chef™ Library Sample Tube barcode and the chip barcode in the Sample Tube Label and Chip Barcode columns respectively. • Yes – Enter the sample name for each sample in the Sample Name (required) column, then select the barcode that is associated with each sample from the dropdown list in the Barcode column. <p>Did you select the Ion Reporter Account and the associated Ion Reporter™ workflow?</p> <ul style="list-style-type: none"> • No – For each sample name listed, make the appropriate selections in each column in the table. • Yes – For each sample name listed, also make the appropriate selections in the Ion Reporter Workflow, Relation, Gender, and IR Set ID columns.
Monitoring Thresholds	Set thresholds for Bead Loading, Usable Sequence, and Key Signal . In the Torrent Suite™ Software Monitor ▶ Runs in Progress screen, an alert is displayed if the values for a run fall below the selected thresholds.

4

Start the Ion Chef™ run

■ Materials required	25
■ Dilute the libraries	25
■ Prepare the consumables	27
■ Add the diluted libraries to the Ion Chef™ Library Sample Tube	28
■ Load the Ion Chef™ System	28
■ Start the Ion Chef™ run	40
■ Unload the chips for sequencing	45

This chapter describes how to perform the following procedures:

- Set up the Ion Chef™ Instrument for use by diluting the libraries, and loading the instrument with all of the required reagents and consumables
- Start an Ion Chef™ run
- Unload the chips for sequencing

Materials required

- Ion 510™ & Ion 520™ & Ion 530™ Kit – Chef (Cat. Nos. [A34461](#), [A34019](#))
- Ion 510™ Chip, Ion 520™ Chip, or Ion 530™ Chip (1 or 2)
- Library or combined library stock solution (1 or 2)
- Molecular-biology grade nuclease-free water
- P200 pipettor and filtered tips

Dilute the libraries

Sample libraries are quantified at the end of the library preparation workflow and are typically diluted to a concentration of 100 pM. The Ion Library Equalizer™ Kit procedure also normalizes library concentration to 100 pM. Barcoded libraries are typically mixed in an equimolar ratio to create a combined library. Libraries or combined libraries can require further dilution before use in Ion Chef™ template runs.

Guidelines for library dilution

- The optimal input concentration for a given library preparation depends on the library and chip type, and often needs to be empirically determined starting from the recommended concentration.
- The recommendations for diluting your sample libraries represent optimal input concentrations for control libraries.
- Recommendations are based on qPCR quantification. If libraries are quantified with an Agilent™ 2100 Bioanalyzer™ instrument, a higher calculated concentration may need to be used for equivalent input.
- Prepare a fresh dilution of each library or combined library before use with the Ion Chef™ System, and use the library dilutions within 48 hours.
- Barcoded libraries are typically combined (or pooled) before templating to allow multiple libraries to be sequenced on a single chip. We recommend that you combine equal volumes of individual barcoded libraries at the same concentration (for example, 100 pM), then dilute the combined library to the final concentration recommended in the following table.
- Follow the recommendations of your library preparation user guide if it recommends a specific final library concentration for an Ion Chef™ run.

Dilute the sample libraries

IMPORTANT! Before proceeding, dilute the two libraries or combined libraries to the optimal input concentration. The quality of your sequencing data relies greatly on achieving the correct concentration of starting library.

Dilute the individual or combined 200-bp or 400-bp stock libraries according to the following table. If needed, use polyclonality and low-quality filter results from a sequencing run performed with ISPs templated at the starting concentration, then titrate up or down to achieve optimal concentrations.

IMPORTANT! Do **NOT** mix template sizes (for example, 200-base and 400-base template run lengths) in a single templating run.

Library length ^[1]	Recommended concentration	Molecules per 25-µL input volume	Templating size in Planned Run setup
<300 bp	25–60 pM	600–900 × 10 ⁶	200
≥300 bp	25–60 pM	600–900 × 10 ⁶	400

^[1] Library length is average insert length plus adapter length.

Note: For the Ion 510™ & Ion 520™ & Ion 530™ Kit – Chef, input for all sizes is identical.

Dilute the control library (if used)

If you are running a control library for troubleshooting purposes, dilute the Human CEPH Control 200 Library or *E. coli* DH10B Control 400 Library, obtained from the Ion S5™ Controls Kit Plus (Cat. No. A30729), as described in the following table.

Control library	Volume of library	Volume of nuclease-free water
Human CEPH Control 200 Library	1 µL	49 µL
<i>E. coli</i> DH10B Control 400 Library	1 µL	124 µL

Prepare the consumables

1. Unbox the Ion 510™ & Ion 520™ & Ion 530™ Chef Reagents cartridge 45 minutes before use and allow it to warm to room temperature.

IMPORTANT! The Reagents cartridge must sit at room temperature for 45 minutes before use.

2. Remove all cartridges and consumables from their packaging, then place them on the bench next to the Ion Chef™ Instrument.

Prepare the following cartridges and consumables:

- Chip Adapter (2)
- Enrichment Cartridge v2
- Tip Cartridge v2
- PCR Plate and Frame Seal v2
- Recovery Station Disposable Lid v2 (2)
- Recovery Tube v2 (12)
- Ion 510™ & Ion 520™ & Ion 530™ Chef Reagents cartridge (from step 1)
- Ion S5™ Chef Solutions

IMPORTANT!

- Before use, gently tap the Reagents and Solutions cartridges on the bench to force the reagents to the bottoms of the tubes.
 - Briefly centrifuge the tube of NaOH (Reagents cartridge, position C) to collect the contents.
-

Note: When stored under normal conditions, a precipitate can form in some tubes of the Ion 510™ & Ion 520™ & Ion 530™ Chef Reagents cartridge. If present, load the cartridge as directed. The precipitate dissolves when the reagents are mixed during instrument operation.

Add the diluted libraries to the Ion Chef™ Library Sample Tube

1. Pipet 25 µL of each diluted library or combined library to the bottom of the appropriate Ion Chef™ Library Sample Tube (barcoded tubes). Load one individual library or combined library per tube. See “Dilute the sample libraries” on page 26.

IMPORTANT! If you are performing a *de novo* sequencing experiment that does not include a reference BAM file, add 4 µL of the Ion S5™ Calibration Standard to your diluted libraries in each Ion Chef™ Library Sample Tube. Cap the tubes, vortex to mix, then centrifuge briefly to collect contents at the bottom of the tube.

Note: If running the Human CEPH Control 200 Library or *E. coli* DH10B Control 400 Library, obtained from the Ion S5™ Controls Kit Plus (Cat. No. [A30729](#)), prepare the control library for use by diluting 1 µL of stock library as described in “Dilute the control library (if used)” on page 27, then add 25 µL of diluted control library to the appropriate Ion Chef™ Library Sample Tube.

2. Cap, then store the sample tubes on ice until you are ready to load them onto the Ion Chef™ Instrument.

Load the Ion Chef™ System

IMPORTANT!

- Rated centrifuge speeds are intended only for operation with the provided buckets and approved consumable chips, tubes, and sample preparation reagents.
 - The Chip-loading centrifuge is rated to operate at the listed rotational frequencies with the chip buckets, chips, and adapters. The centrifuge must be load-balanced. Proper care must be taken to load the buckets properly. If excessive vibrations arise, check that items are installed properly and rotors are load-balanced.
 - Use only the materials supplied in the Ion 510™ & Ion 520™ & Ion 530™ Kit – Chef to run the centrifuges at the rated speeds. Do not remove or change the rotors. Inspect the buckets before each use to assure normal operation.
 - Confirm that the instrument is powered on and was cleaned following the last use.
 - Ensure that all components are clean and dry before loading them onto the Ion Chef™ Instrument.
 - Ensure that the Reagents and Solutions station compartments are free of condensate before loading components.
-

Follow the procedure described in the following sections to load the Ion Chef™ Instrument.

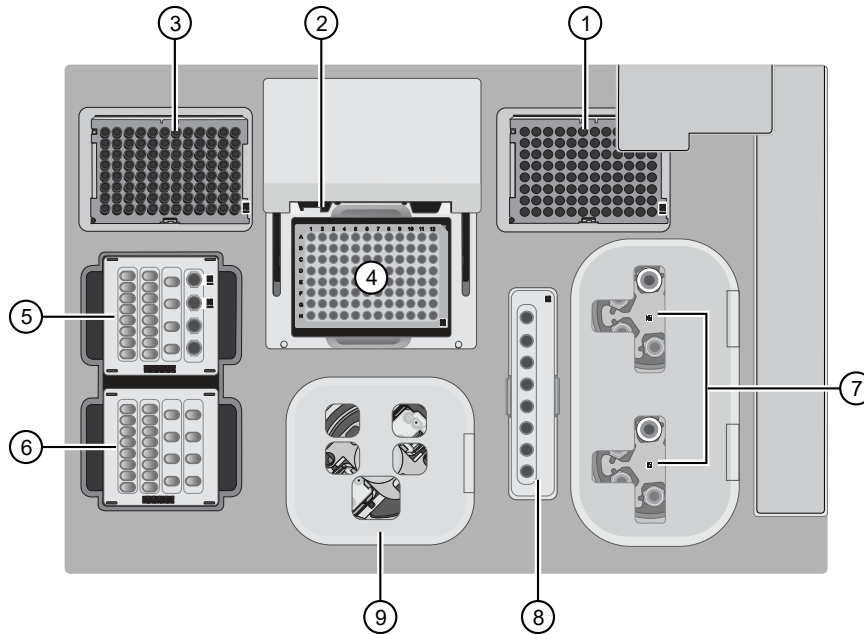

A schematic of a loaded Ion Chef™ Instrument

- | | |
|--|---|
| ① Empty tip rack (move from new Tip Cartridge position) | ⑥ Ion S5™ Chef Solutions cartridge |
| ② Frame Seal v2 | ⑦ Recovery Tubes and Recovery Station Disposable Lid v2 |
| ③ New Tip Cartridge | ⑧ Enrichment Cartridge v2 |
| ④ PCR Plate | ⑨ Chip Adapter/Chip assemblies |
| ⑤ Ion 510™ & Ion 520™ & Ion 530™ Chef Reagents cartridge | |

Load the pipette tip racks and PCR Plate

1. Tap  (**Open Door**) in the instrument touchscreen to open the instrument door, then wait for the latch to open.
2. Lift the instrument door to the top of the travel until the latch mechanism engages.

IMPORTANT! Lift the door from the center.

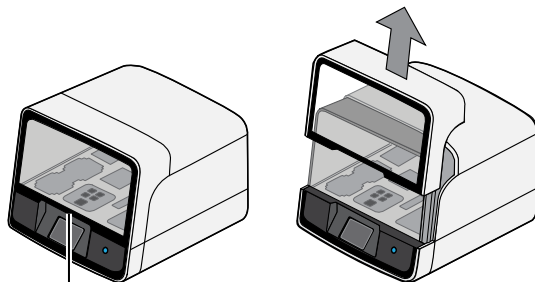

- ① Center of door

3. Load an empty pipette tip rack in the *Used (Waste)* Pipette Tip Position, then change gloves.

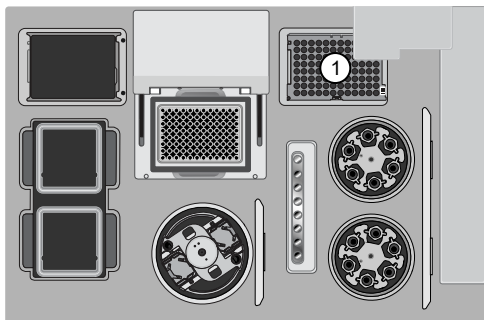

① Used Pipette Tip Position

IMPORTANT!

- Ensure that the pipette tip rack in the *Used (Waste)* Pipette Tip Position does not contain any tips. The instrument aborts the run if tips are present in the *used* position.
- To prevent contamination, change gloves immediately after moving the empty pipette tip rack to the *Used (Waste)* Pipette Tip Position.

Note: A small amount of dried residue can be present in the tub of the empty pipette tip rack after a run. This residue does not affect the next run.

4. Unwrap a new Tip Cartridge v2 and remove the cover to expose the pipette tips, then load it in the *New* Pipette Tip Position. See the figure in step 5.
5. Slide the catch forward to allow the locking bracket to pivot upward. Load the Tip Cartridge v2 into the *New* Pipette Tip Position, pull the bracket downward, then push the catch backward to lock the bracket and cartridge in place.

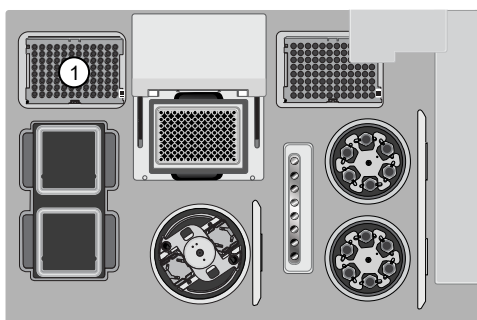

① New Pipette Tip Position

② Bracket

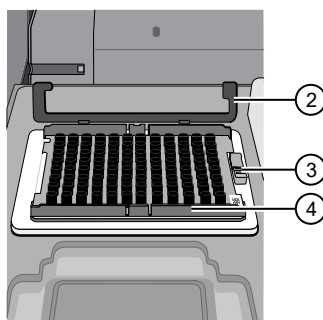

③ Catch

④ New Tip Cartridge v2

6. Load a new PCR plate into the thermal cycler sample block, then slide a new Frame Seal v2 under the automated heated cover.

IMPORTANT! When the Frame Seal v2 is positioned correctly, its tabs project upward and contact the heated cover.

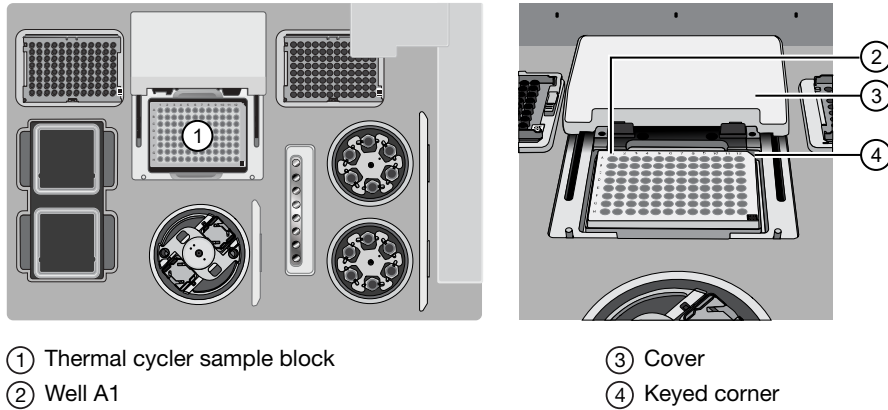

Load the Reagents and Solutions cartridges

IMPORTANT! Thaw the Reagents cartridge at room temperature for 45 minutes before use.

1. Gently tap the Ion 510™ & Ion 520™ & Ion 530™ Chef Reagents cartridge on the bench to force the reagents to the bottoms of the tubes.
2. If bubbles are present below the surface of the liquid, repeat step 1.
3. Load the cartridge into the Reagents station so that it snaps into place and is level on the deck.

IMPORTANT! Do not force the Ion Chef™ cartridges into place. Each cartridge fits only one location on the deck and in one orientation. If a cartridge does not fit, confirm that you are loading the correct cartridge in the correct orientation.

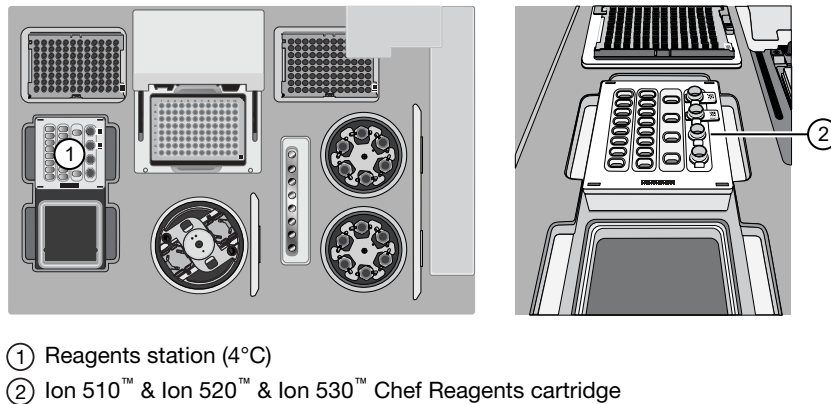

- Uncap, then load the two Library Sample Tubes, each containing 25 µL of diluted library or combined library pool, into Positions A and B on the Reagents cartridge.

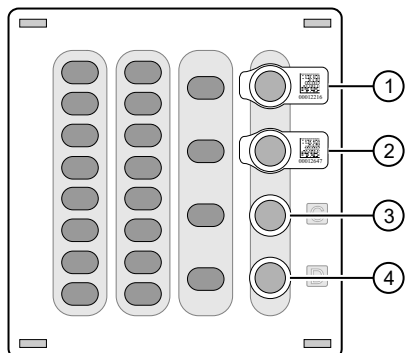

- | | |
|------------------------|---------------------------|
| ① Position A (Library) | ③ Position C (NaOH) |
| ② Position B (Library) | ④ Position D (Empty tube) |

IMPORTANT!

- Orient the sample tubes so that the barcodes are visible and oriented to the right.
- Remove the caps from each Library Sample Tube before proceeding.
- Because 200- and 400-base-read libraries require different run parameters, do not load a 200-base-read library and 400-base-read library in a single Ion Chef™ run. Both libraries that are loaded in a run must have a similar read length.

- Uncap both the tube of NaOH in Position C and the empty tube in Position D on the Reagents cartridge.

IMPORTANT! When the Reagents cartridge is loaded:

- Press down on each Library Sample Tube to ensure that they are firmly seated in the cartridge.
- **Ensure that *all* tubes are uncapped, including the tube at Position D.**

- Gently tap the Ion S5™ Chef Solutions cartridge on the bench to force the reagents to the bottoms of the tubes.
- Load the Solutions cartridge into the Solutions station until it snaps into place and is level on the deck.

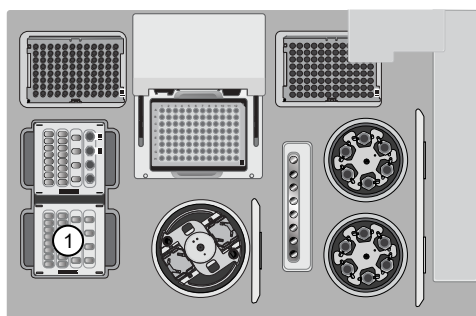

① Solutions station (room temperature)

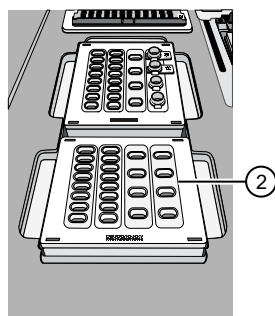

② Ion S5™ Chef Solutions cartridge

Load the Recovery Tubes and Enrichment Cartridge v2

1. Load six Recovery Tubes into each Recovery centrifuge.

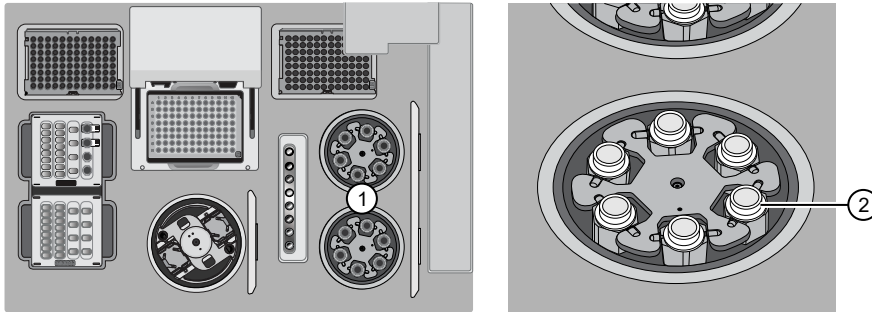

① Recovery centrifuges

② Recovery Tube v2

Before sealing each centrifuge, confirm that:

- The centrifuge is load-balanced with all required consumables.

IMPORTANT! The centrifuge must be load-balanced.

- The buckets are securely seated in the centrifuge rotors.
- The buckets are oriented correctly in the centrifuge so that they pivot outwards.

2. Place a Recovery Station Disposable Lid v2 over each centrifuge by lining up the tab with the depression on the deck, then snap into place. Ensure that the lids snap completely into place by applying firm downward pressure along the lid perimeter.
3. Close the hinged cover of the Recovery centrifuges. Confirm that the port of each disposable lid is positioned toward the rear of the instrument.

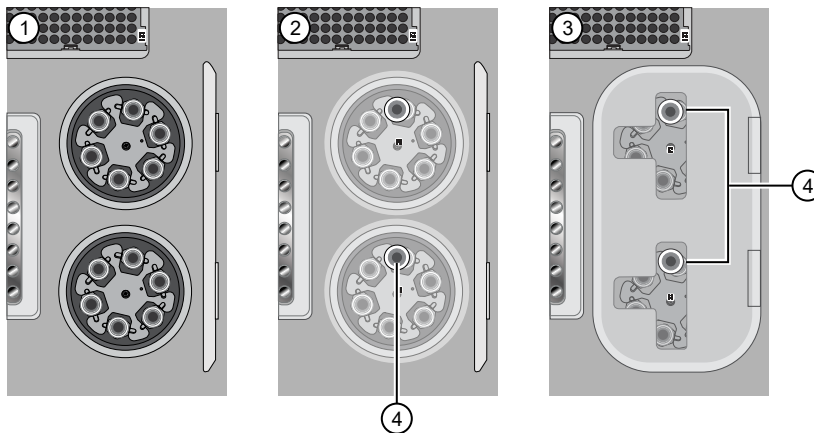

① Recovery Tubes installed

② Recovery Station Disposable Lid v2 installed

③ Recovery centrifuge cover closed

④ Port

IMPORTANT!

- Do not obstruct or place any object on top of the Recovery centrifuge cover.
- Use only the supplied materials, including buckets and disposables, to run the centrifuges at the rated speeds. Do not remove or change the rotors. To ensure normal operation, inspect the buckets before each use.

4. Load the Enrichment Cartridge v2, then press down on the cartridge to ensure that it is level with the instrument deck.

IMPORTANT! Confirm that the Enrichment Cartridge v2 is loaded so that the lettering on the cartridge is right-side-up.

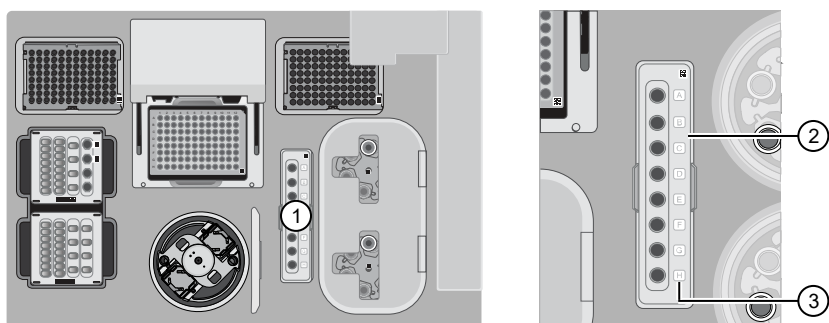

- ① Enrichment station
- ② Enrichment Cartridge v2

- ③ Lettering

Load the Chip-loading centrifuge

1. Load each chip that you will use for templating and sequencing into a centrifuge bucket, then attach a Chip Adapter to the assembly.
 - a. Place the chip in the chip-loading bucket with the keyed corners of the chip and bucket aligned, then align the wells of the Chip Adapter to the wells of the chip, orienting the adapter onto the chip so that the chip barcode is visible.
 - b. Place the adapter onto the chip, then insert the stationary tabs at the reservoir end of the adapter into the slots of the bucket.
 - c. Gently squeeze the flexible tabs at the other end of the adapter into the bucket slots until the adapter locks into place.
 - d. Ensure that the tabs at all four corners of the adapter are fitted into the slots in the centrifuge bucket. Loading can fail if the adapter is not attached securely.

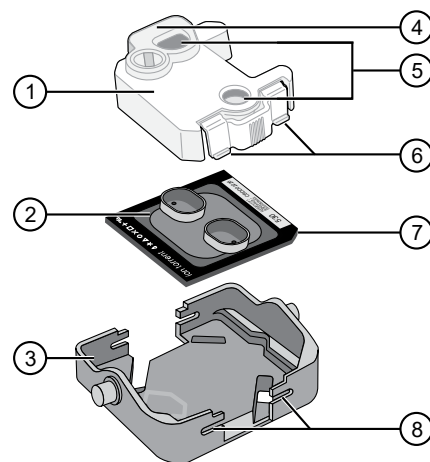

- ① Chip Adapter
- ② Ion Chip™
- ③ Bucket
- ④ Reservoir end of Chip Adapter
- ⑤ Ports (align with chip)
- ⑥ Flexible tabs
- ⑦ Keyed corner (align with bucket)
- ⑧ Slots

Note: If desired, you can label the tops of chips to distinguish them. Do not obstruct or overwrite the chip barcode with your label.

2. Load the adapter/chip/bucket assemblies into the Chip-loading centrifuge.

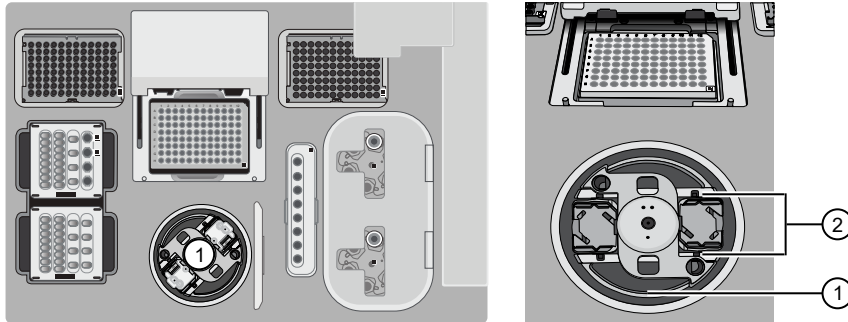

① Chip-loading centrifuge

② Mounting grooves

IMPORTANT! When the Chip-loading centrifuge is loaded, ensure that each Chip Adapter is firmly attached to a bucket, and that the buckets are securely seated in the centrifuge rotors.

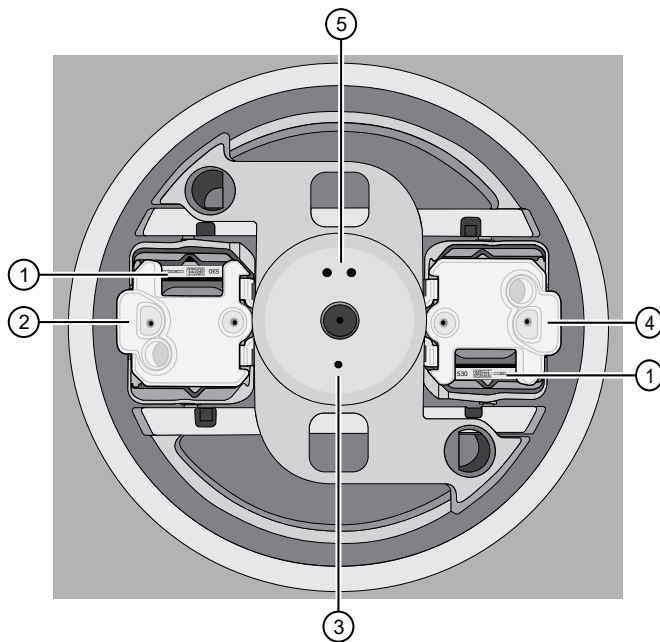

① Chip barcode
② Chip position 1
③ Position 1 marker hole

④ Chip position 2
⑤ Position 2 marker hole

Note:

- Position 1 of the Chip-loading centrifuge is the position 90° clockwise from the single hole in the rotor bucket cover at rest. The chip that is loaded in Position 1 is loaded with ISPs prepared from the DNA library in the Ion Chef™ Library Sample Tube that is loaded in Position A of the Reagents cartridge.
 - The chip that is loaded in Position 2 of the centrifuge is loaded with ISPs prepared from the DNA library in the Ion Chef™ Library Sample Tube that is loaded in Position B of the Reagents cartridge.
 - If you are performing a mixed chip run, ensure that the chips are loaded in the appropriate positions of the centrifuge.
-

3. Ensure that the centrifuge is load-balanced and the chip buckets are securely seated and oriented correctly in the centrifuge so that they pivot 90° outwards when touched. Then close the lid of the Chip-loading centrifuge.
-

IMPORTANT! Do not obstruct or place any object on top of the lid.

Confirm that consumables are correctly installed

- Confirm that each cartridge is at the correct location and in the correct orientation.
- Press down on all cartridges to confirm that they are firmly pressed into place.
- Confirm that all tubes in the Ion 510™ & Ion 520™ & Ion 530™ Chef Reagents cartridge, including the tube of NaOH in Position C, are uncapped and firmly pressed into place.
- Confirm that the centrifuge lids are installed correctly so that the port is oriented toward the rear of the instrument.
- Confirm that the tube and chip buckets are seated securely in the rotor arms of the Chip-loading and Recovery centrifuges, and that the consumables they contain are correctly installed.



CAUTION! To ensure correct and safe instrument operation, you must confirm that all consumables are installed correctly to the deck before you start a run. The Ion Chef™ Instrument does not verify all aspects of the consumable setup before beginning each run.

Single chip loading workflow

You can set up an Ion Chef™ run to load a single chip instead of two, using the Ion Chef™ S5 Series Chip Balance loaded opposite to the sequencing chip in the Chip-loading centrifuge. The Ion Chef™ S5 Series Chip Balance is provided in the Ion S5™ Installation Kit.

Load the Ion Chef™ Instrument as you would normally load the system. For single chip loading, perform the following steps:

1. Add the single diluted library or combined library to an Ion Chef™ Library Sample Tube, then load the tube into Position A of the Reagents cartridge.
2. Load an empty Ion Chef™ Library Sample Tube into Position B of the Reagents cartridge. Uncap both tubes.
3. Load the chip in Position 1 and the Ion Chef™ S5 Series Chip Balance in Position 2 of the Chip-loading centrifuge.

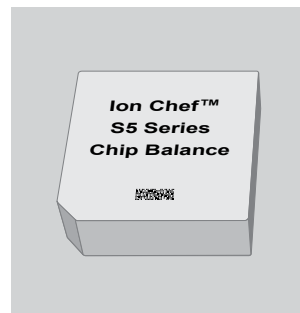

Ion Chef™ S5 Series Chip Balance

IMPORTANT! Do not use Ion Chef™ 314, 316/318, or P-Series versions of the chip balance with the Ion 510™ Chip, Ion 520™ Chip, or Ion 530™ Chip. Each chip balance is weight-matched to the chip (and corresponding chip adapter) specified on the chip balance label.

Note: Position 1 of the Chip-loading centrifuge is the position 90° clockwise from the single hole in the rotor bucket cover at rest.

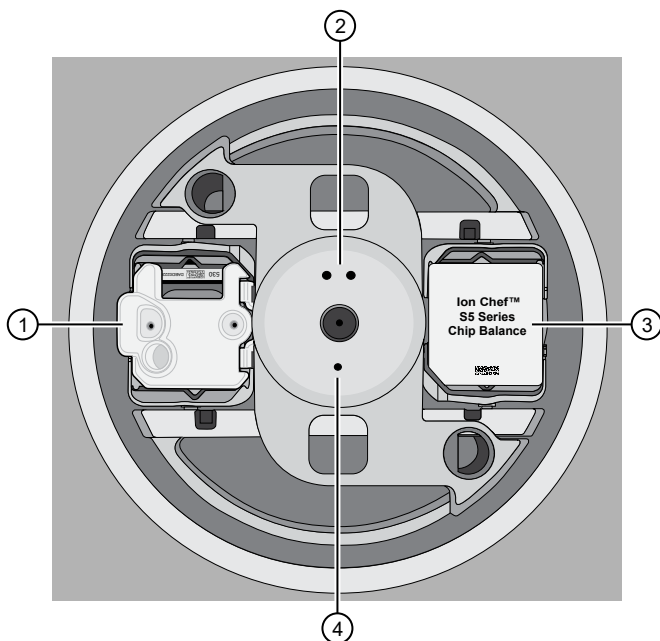

① Position 1 (chip)

② Position 2 marker holes

③ Position 2 (Chip Balance)

④ Position 1 marker holes

4. Resume the normal workflow in “Load the Chip-loading centrifuge” at step 3. The Ion Chef™ Instrument detects the presence of the single chip during Deck Scan before the run starts.

Ion Chef™ pre-run checklist

1) A new Ion Chef™ Tip Cartridge v2 is loaded in the New Pipette Tip position.
 2) Bracket is pulled downward to lock the tip cartridge in place.

1) Reagents cartridge contents are thawed (leave at room temperature for 45 minutes).
 2) **Reagents cartridge tubes are uncapped** and pressed into place at the Reagents station so that the tubes are **firmly seated** and **level** with the deck.
 3) Library sample tubes are **firmly seated** and in the correct orientation with barcodes facing the PCR Plate and caps removed.

1) Solutions cartridge is pressed into place at the Solutions station so that the cartridge is **firmly seated** and **level** with the deck.

1) A new PCR Plate is loaded in the thermal cycler sample block.
 2) A Frame Seal v2 is in place and oriented under the heated cover.

1) The tip rack from previous run is transferred from the New Pipette Tip position to the Used Pipette Tip position.

1) Recovery Tubes (v2) are securely seated in the Recovery centrifuge buckets.
 2) Recovery centrifuges are load-balanced.
 3) Recovery Station Disposable Lids (v2) are positioned so that the port is oriented toward the rear of the instrument.

1) Adapter/chip assembly is correctly seated in the Chip-loading centrifuge buckets, with the adaptor clips inserted into the bucket slots.
 2) Centrifuge buckets containing an adapter/chip assembly or chip balance are securely seated in the centrifuge rotor, and freely pivot 90° outwards.
 3) Chip-loading centrifuge is load-balanced.

1) Enrichment Cartridge v2 is pressed into place at the Enrichment station so that the cartridge is **firmly seated** and **level** with the deck.
 2) Lettering on the cartridge is right-side up and positioned to the right of the enrichment tubes.

Start the Ion Chef™ run

1. Ensure that you have loaded the instrument with all kits and consumables.
2. On the Ion Chef™ Instrument home touchscreen, tap **Set up run**.



3. Tap **Step by step** to have the instrument lead you through the instrument setup, or tap **Quick Start** to skip the instrument setup screens and proceed to Deck Scan.

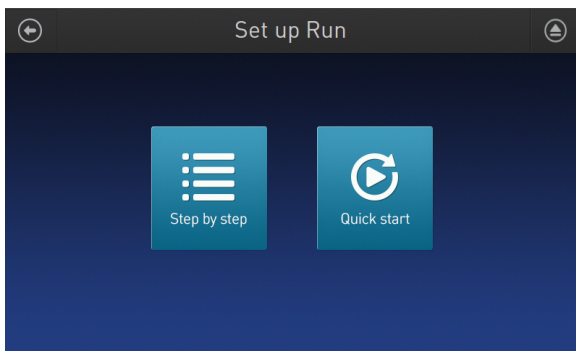

If you selected **Quick Start**, proceed to step 5, otherwise proceed to step 4.

4. (*Step by step setup only*) In the **Run Options** screen, tap **Prepare Chip** to select the templating run option.

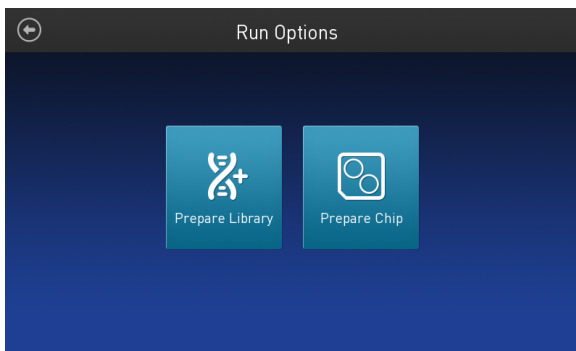

- Follow the on-screen instructions. When prompted, close the instrument door by first lifting it slightly to disengage the locking mechanism, then push down on the door until the locks engage.

IMPORTANT! Do not close the door by pulling it straight down from the open position. You must lift the door slightly before you can close it. Ensure that both sides of the door are locked after closing it.

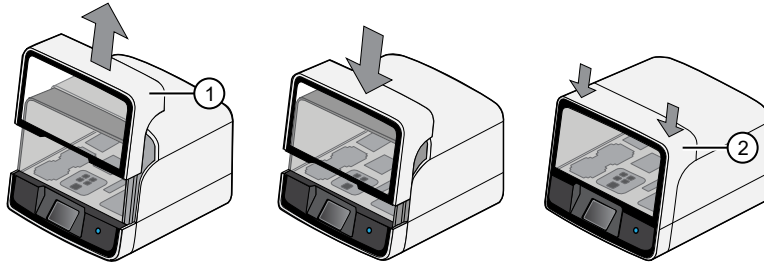

① Open door position

② Locked door position

After the door closes, the instrument vision system activates.

- When prompted, tap **Start check** to start Deck Scan. Wait while the instrument scans the barcodes of all consumables and reagents to ensure their presence and compatibility. During Deck Scan, the touchscreen displays warnings if the Ion Chef™ Instrument detects missing or incompatible consumables. You must address all warnings before the run can start. After you address each condition, tap **Yes** to continue.

IMPORTANT! The Deck Scan function is not a substitute for manual inspection of the reagents and consumables on the Ion Chef™ Instrument before starting a run. To ensure proper and safe instrument operation, ensure that all consumables are installed correctly before you continue.

- When Deck Scan is complete, tap **Next** to display the **Data Destination** screen.

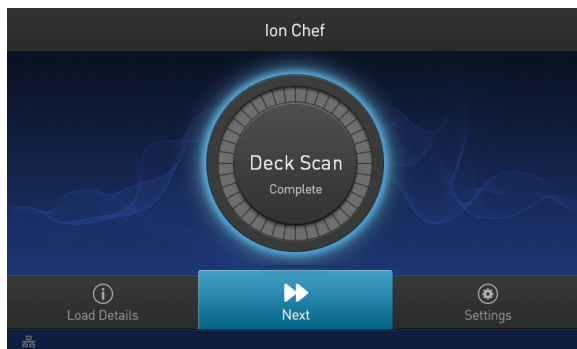

- Ensure that the instrument displays the correct kit types, chip positions (mixed-chip run), chip type, chip barcodes, and Planned Run. If the correct Planned Runs do not display, tap the dropdown list  to select the Planned Run for each chip, then tap **Next**.

Note: If the Ion Chef™ Instrument does not auto-populate the correct Planned Run, ensure that the Sample Tube Label has been entered correctly in the Planned Run.

IMPORTANT! If the kit and chip type are not correct, ensure that you are using the correct kit and chip. If you are using the correct kit and chip, and an incorrect kit or chip type is displayed on the screen, contact Technical Support.

- On the **Run Options** screen, tap the appropriate option to complete the run, then enter the desired time of run completion if needed.

The Ion Chef™ Instrument provides two options for obtaining quality control (QC) samples that can be used to evaluate templating efficiency. Depending on your selection, the QC samples are made available either during or after the run. In either case, you can obtain unenriched samples from the corresponding Library Sample Tubes at Positions A and B on the Reagents cartridge, or enriched samples from Positions A and E on the Enrichment Cartridge v2.

By selecting	You can obtain the QC samples	Approximate time after run start
Time	immediately after the run ends, at the time you specify:	<ul style="list-style-type: none">• 200-bp libraries: 14 hours 40 minutes.• 400-bp libraries: 13 hours 40 minutes.
Pause	when the instrument pauses operation before the chip loading step:	<ul style="list-style-type: none">• 200-bp libraries: 13 hours 15 minutes.• 400-bp libraries: 12 hours 15 minutes.

Note:

- The library in the Ion Chef™ Library Sample Tube loaded in Position A of the Reagents cartridge is templated onto ISPs that can be sampled in Position E of Enrichment Cartridge v2 after a run. The library in the Ion Chef™ Library Sample Tube loaded in Position B is templated onto ISPs that can be sampled in Position A of Enrichment Cartridge v2.
- Select **Pause** if you are uncertain of library quality and want to evaluate templating efficiency before chips are loaded. If you do not pause the run, you can collect QC samples after the run. Save the samples until sequence analysis is complete to have them available for troubleshooting.

10. On the **Run Options** screen, tap **Start run** to start the run.

Note: If you must stop the run for any reason, tap **Cancel**, then tap **Yes** to confirm the cancellation.

If the Ion Chef™ Instrument encounters a problem during the run, it aborts the run and displays the error on the instrument touchscreen. If a run fails, perform the following tasks.

- a. Remove the consumables from the deck, then clean the instrument. If possible, retain the consumables for troubleshooting.
 - b. Reset, then attempt to start the run again. If the run fails again, contact Technical Support to troubleshoot the problem. Record the error message for reference.
11. Initialize the sequencer at least 50 minutes before the Ion Chef™ System finishes chip loading. For more information, see Chapter 5, “Initialize the sequencer”.
Initialization of the instrument can be performed up to 24 hours before starting a sequencing run. If the intent is to perform two sequencing runs per initialization, the first run must be completed and the second run must be started within the 24-hour period. By initializing the sequencer before completion of chip loading, you ensure that the chips can be sequenced as soon as possible after loading is complete.

12. If you chose to pause the run to analyze the templating efficiency, remove the samples for testing when prompted to do so by the Ion Chef™ Instrument.

Note: The time varies for different libraries.

- 200–bp libraries: 13 hours 15 minutes.
- 400–bp libraries: 12 hours 15 minutes.

- a. When prompted to remove the QC sample, open the instrument door.

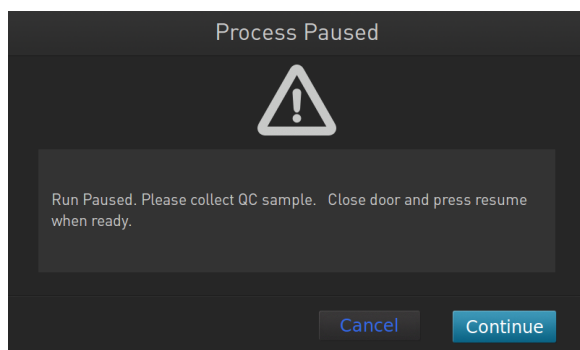

IMPORTANT! If you unintentionally close the instrument door before you obtain the QC samples, you must wait until the end of the run before you can collect them. You cannot pause the run or open the door after it has been closed.

- b. Transfer the entire volume of each QC sample from Positions A and B of the Ion 510™ & Ion 520™ & Ion 530™ Chef Reagents cartridge on the instrument deck to two new labeled microcentrifuge tubes.

IMPORTANT! Do not remove the Library Sample Tubes from the Ion 510™ & Ion 520™ & Ion 530™ Chef Reagents cartridge.

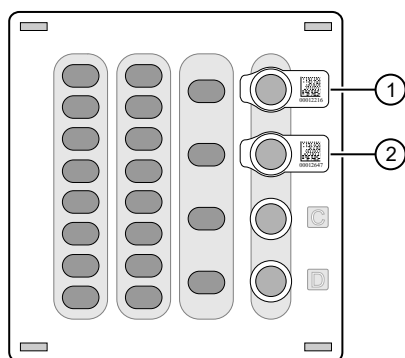

① Position A (QC Sample)

② Position B (QC Sample)

- c. If you are performing quality assessment of enriched samples, transfer QC samples from positions A and E of the Enrichment Cartridge v2 to two new labeled microcentrifuge tubes.
- d. Analyze the QC samples. For more information, see “Quality control of Ion 510™ ISPs, Ion 520™ ISPs, or Ion 530™ ISPs” on page 73.

- e. Close the instrument door, then tap **Continue** to complete the run.
13. When the run is complete, unload the Ion Chef™ Instrument and sequence the chips immediately. You can collect QC samples from the Reagents and/or Enrichment cartridges if you have not done so already.

IMPORTANT! Liquid can be present in the chip wells after the Ion Chef™ run. Do NOT remove any residual liquid from the wells.

Note: If you cannot sequence a loaded chip immediately or plan to sequence two chips per initialization, place the chip into a separate chip storage container and store at 4°C until you are ready to sequence it (up to 6–8 hours maximum).

Unload the chips for sequencing

1. Open the instrument door.
 - a. In the instrument touchscreen, tap  (**Open Door**), then wait for the latch to open.
 - b. Lift the instrument door to the top of the travel until the latch mechanism engages.

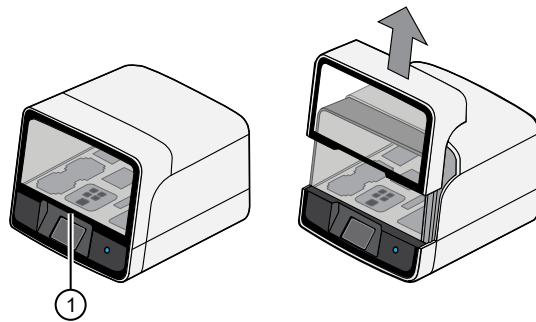

① Center of door

2. Open the lid of the Chip-loading centrifuge, then unload both adapter/chip/bucket assemblies from the instrument.

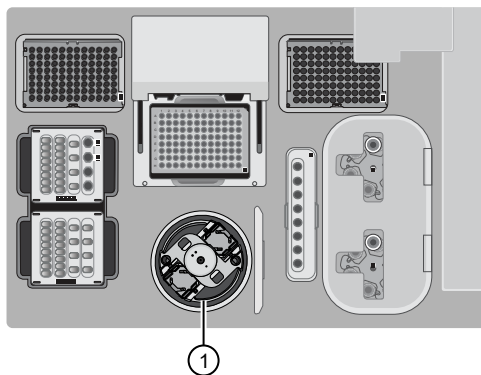

① Chip-loading centrifuge

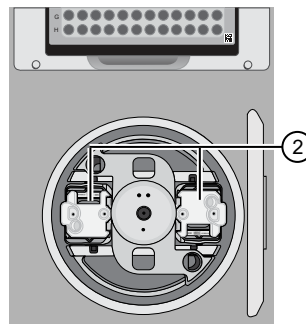

② Adapter/chip/bucket assemblies

3. Unload each chip from the adapter/chip/bucket assembly.
 - a. Apply pressure to both ends of the Chip Adapter, then remove and discard the Chip Adapter.
 - b. Grasp the chip by its edges, carefully lift the chip out of the bucket, then set it aside on a clean, static-free surface. Return the bucket to the Chip-loading centrifuge.

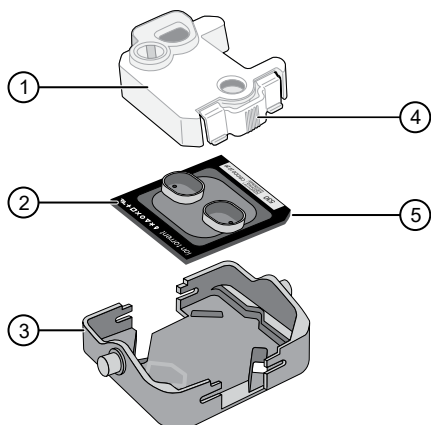

- ① Chip Adapter
- ② Chip
- ③ Bucket

- ④ Flexible tabs
- ⑤ Keyed corner of chip

4. Close the instrument door by first lifting it slightly to disengage the locking mechanism, then push down on the door until the locks engage.

IMPORTANT! Do not close the door by pulling it straight down from the open position. You must lift the door slightly before you can close it. Ensure that both sides of the door are locked after closing it.

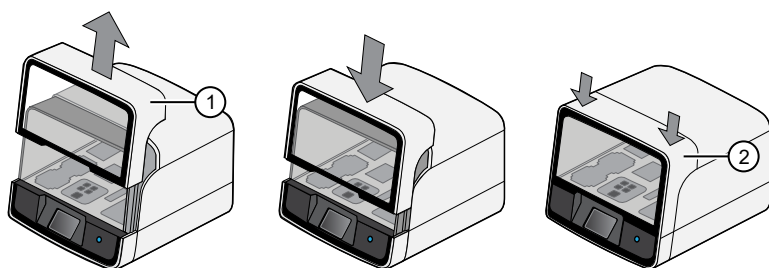

- ① Open door position

- ② Locked door position

5. Load one or both chips into a sequencer, then promptly start the sequencing run or runs.

If you cannot sequence a loaded chip immediately or plan to sequence two chips per initialization, place the chip into a separate chip storage container and store at 4°C until you are ready to sequence it (up to 6–8 hours maximum).

IMPORTANT!

- Liquid may be present in chip wells after the Ion Chef™ run. Do NOT remove any residual liquid from the wells.
 - If you choose to store a loaded chip, remove the chip from 4°C storage (but keep it in the storage container) at least 20 minutes before running it, allowing the chip to warm to room temperature.
-

5

Initialize the sequencer

- Ion S5™/Ion GeneStudio™ S5 Systems component positions 48
- Before you begin 49
- When a manual cleaning of the sequencer is required 49
- Initialize the sequencer 50

Initialization takes ~50 minutes.

Ion S5™ /Ion GeneStudio™ S5 Systems component positions



- ① Touchscreen
- ② Power button
- ③ Ion S5™ Sequencing Reagents cartridge
- ④ Chip clamp
- ⑤ Ion S5™ Wash Solution bottle. Waste reservoir located behind the Ion S5™ Wash Solution bottle (shown on the right).
- ⑥ Ion S5™ Cleaning Solution bottle
- ⑦ Waste reservoir

Note:

- The system uses RFID technology to verify that the proper reagents are loaded in positions 3, 5, and 6. Reagents that exceed their expiration date or usage count generate an error message prompting the user to replace the reagent before performing the run.
- RFID regulatory information can be found on the main screen under **Options ▶ Regulatory info**.

Before you begin

The Ion S5™ Sequencer, Ion S5™ XL Sequencer, and Ion GeneStudio™ S5 Series Sequencer are equipped to verify the compatibility of each chip and consumable that is loaded during initialization and sequencing, and that these components do not exceed their expiration date. To avoid exceptions during initialization, inspect this information for each consumable before installing onto the instrument.

- Unbox the Ion S5™ Sequencing Reagents cartridge 45 minutes before use, then allow it to equilibrate to room temperature.
Do not remove the Ion S5™ Sequencing Reagents cartridge from its packaging until immediately before loading, so that you can return the unused cartridge to storage if your sequencing run is delayed.
- Unbox the Ion S5™ Wash Solution bottle. Invert the bottle 5 times within its vacuum-sealed bag, then swirl at an angle to mix thoroughly.
- Remove the Ion S5™ Wash Solution bottle from its vacuum-sealed bag, then remove the red cap from the Ion S5™ Wash Solution and Ion S5™ Cleaning Solution bottles immediately before installing on the instrument.

When a manual cleaning of the sequencer is required

The Ion S5™ Sequencer, Ion S5™ XL Sequencer, and Ion GeneStudio™ S5 Series Sequencer require that a cleaning be performed before initialization. Cleaning is normally performed automatically at the completion of the previous sequencing run. When two sequencing runs are performed on a single initialization, the post-run cleaning is performed after the second sequencing run. However, if the "Enable post-run clean" checkbox (see "Start the sequencing run") is deselected to allow a second run, and a second run is not performed, the instrument will not allow the subsequent initialization to proceed until a manual cleaning has been performed. For more information on how to perform a manual cleaning, see "Perform a manual cleaning of the sequencer" on page 70.

If the sequencer is initialized and a sequencing run is not started within 24 hours, or a run is not started or completed due to a power failure or an abort, do not perform a manual cleaning. An instrument reset run is required before reinitialization. For more information, see "Perform an instrument reset run with an initialized sequencer that is loaded with an unused Reagents cartridge" on page 71.

Initialize the sequencer

1. In the instrument touchscreen main menu, tap **Initialize**.



The door, chip, and Reagent cartridge clamps unlock.

2. When prompted, remove the Ion S5™ Wash Solution bottle to access the waste reservoir, then remove and empty the waste reservoir.
3. Reinstall the empty waste reservoir.
4. Replace the expended Ion S5™ Sequencing Reagents cartridge with a new cartridge equilibrated to room temperature.
5. Ensure the new Ion S5™ Wash Solution bottle is thoroughly mixed. Then remove the red cap and install.

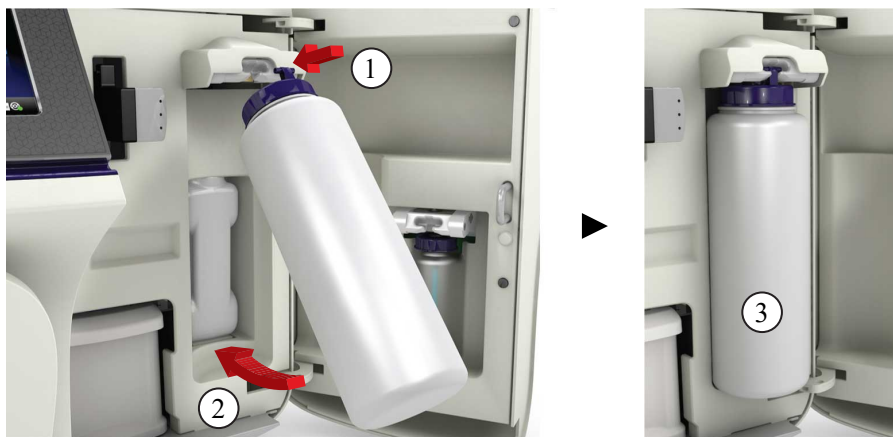

6. Ensure that the used sequencing chip from the previous run is properly seated in the chip clamp and the chip clamp is pushed in all the way.

7. If necessary, install a new Ion S5™ Cleaning Solution bottle.

Note: The Ion S5™ Cleaning Solution bottle contains sufficient reagent to complete 4 cleanings.

8. Close the door, then tap **Next**.

The instrument confirms that the consumables and chip are properly installed and that the Ion S5™ Cleaning Solution contains sufficient reagent to perform the post-run clean. Follow all on-screen recommendations to ensure proper installation of required consumables.

IMPORTANT! If the allowed number of post-run cleans has been met, the instrument prompts the user to replace the Ion S5™ Cleaning Solution bottle.

Note: If a **Checking Reagent: Failed** warning appears, see “Reagent Check fails” on page 67.

9. When initialization is complete (~50 minutes), tap **Home**.

The instrument is now ready for a sequencing run.

For information on recycling and disposal of used components, see “Reagent consumables disposal” on page 55.

6

Start the sequencing run

- Place chip in chip clamp 52
- Start the sequencing run 53
- Maintain the sequencer 55
- Reagent consumables disposal 55

Place chip in chip clamp

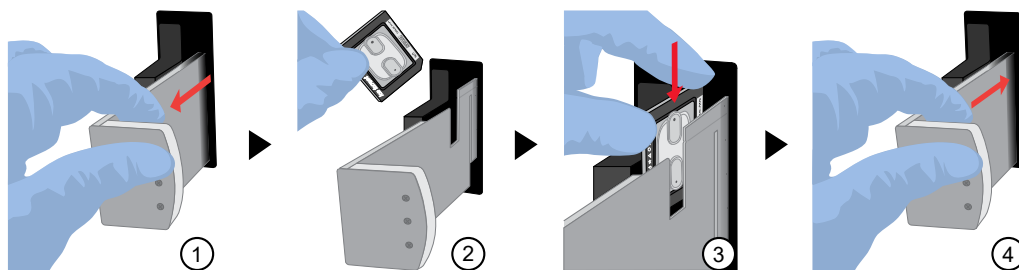

1. Slide the chip clamp out.
2. Remove the chip currently in the clamp.
3. Place the appropriate loaded chip in the chip clamp with the chip notch in the bottom-front corner.

Note: Do not force the chip into the clamp. If the chip does not fit easily in the clamp, ensure that the notch is oriented as shown in the drawing.

4. Slide the metal tab in fully to engage the clamp, then close the instrument door.

Start the sequencing run

We recommend that you start a sequencing run as soon as possible after chip loading and instrument initialization are complete. However, successful sequencing runs can be started up to 24 hours after instrument initialization.

IMPORTANT!

- Do *not* press the power button during a run. Interrupting power to the instrument during a run can result in sequencing run failure and loss of sample.
- We recommend that you verify the status of the Planned Run you will use as "Planned" before inserting the loaded chip. If your Planned Run does not advance to the Planned status in Torrent Suite™ Software after successful completion of an Ion Chef™ run, see "Planned Run status does not advance to "Planned"" on page 65.

-
1. After completion of initialization, tap **Run** in the instrument touchscreen. The door and chip clamp unlock.
 2. Remove the used sequencing chip, then secure a chip loaded with template-positive Ion Sphere™ Particles in the chip clamp.
 3. Push the chip clamp all the way in to engage, close the instrument door, then tap **Next**.

Note: Do not remove the chip from the chip clamp until completion of the run. Removing and reinserting the chip risks introducing air bubbles in the chip.

4. Confirm that the correct Planned Run has auto-populated. If this run is the first of two sequencing runs on this initialization, **deselect** the **Enable post-run clean** checkbox, then tap **Review**.

IMPORTANT!

- Failure to deselect the checkbox results in a cleaning performed automatically after the first run. A second run is not available.
 - When starting the second sequencing run on a single initialization, ensure that the **Enable post-run clean** checkbox is selected so that the post-run cleaning is performed automatically.
-

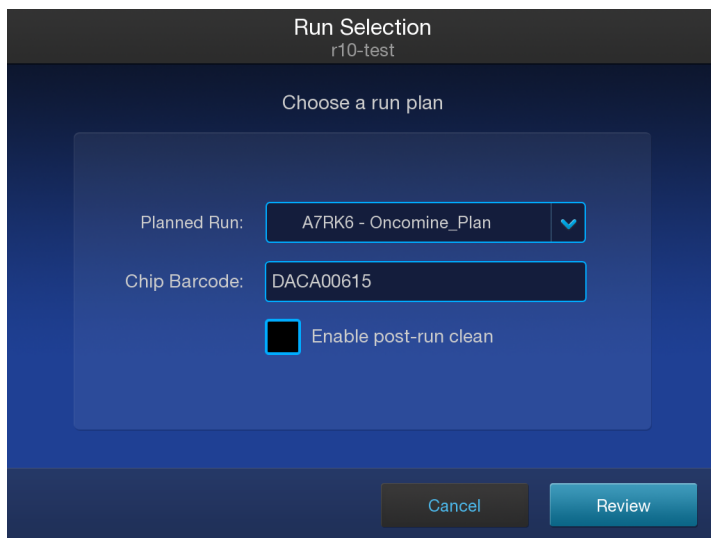

5. Confirm that the remaining pre-populated settings are correct, or tap **Edit** to make changes if needed.

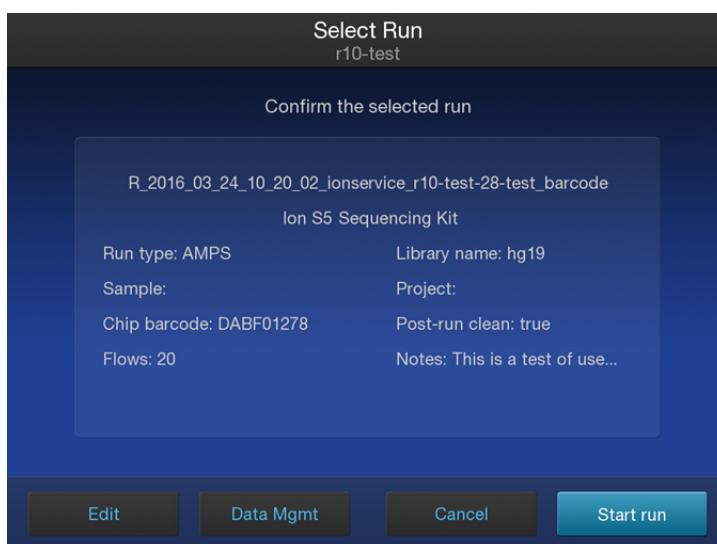

6. Confirm that the instrument door is closed, then tap **Start run** to begin the sequencing run.

IMPORTANT! During a run, do not open the instrument door, and avoid touching the instrument. Touching the instrument during the sequencing run can reduce the quality of the measurements.

When the sequencing run is complete, the instrument automatically performs the cleaning procedure unless the **Enable post-run clean** checkbox was deselected. After cleaning, the touchscreen returns to the main menu. Use Torrent Suite™ Software to review the results.

If you are sequencing a second chip on a single initialization, start the second run within 24 hours of start of initialization.

Maintain the sequencer

Materials required

- Lint-free wipes
- 70% isopropanol
- *(Optional)* 10% bleach solution

Clean or decontaminate the sequencer

In the event of a spill or leak on or inside the instrument, perform the following steps.

Note: Dispose of all waste in appropriate liquid or solid waste containers.

1. Remove the Ion S5™ Wash Solution bottle, then remove and empty the waste reservoir.
2. Remove the Ion S5™ Sequencing Reagents cartridge.
3. Inspect the waste and nucleotide reagent bays for liquid.
4. Using absorbent paper soak up as much liquid as possible, then wash the affected area with 10% bleach solution.
5. Wipe the affected surfaces with 70% isopropanol, then allow to air-dry.

Reagent consumables disposal

IMPORTANT! Follow all applicable local, state/provincial, and/or national regulations when recycling or disposing of Ion S5™ reagent consumables.

CO₂ scrubber removal and disposal

To properly dispose of the CO₂ scrubber, you must first remove it from the Ion S5™ Sequencing Reagents cartridge.

1. Invert the Ion S5™ Sequencing Reagents cartridge over an appropriate receptacle to drain all residual liquid.
2. Wearing gloves, insert the Ion S5™ Cartridge Tool firmly into the CO₂ scrubber until the flange stops on the top of the cartridge.

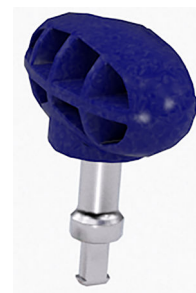

Ion S5™ Cartridge Tool

3. Pull straight up on the tool while holding the nucleotide reagent cartridge down.



4. Remove the scrubber from the cartridge tool, then dispose of the scrubber according to applicable hazardous waste regulations.

The remaining nucleotide reagent cartridge should be disposed of appropriately.

Recycle Ion S5™ Wash Solution and Ion S5™ Cleaning Solution bottles

The Ion S5™ Wash Solution and Ion S5™ Cleaning Solution bottles are made of recyclable plastic.

1. Open the expended bottle by unscrewing the cap.
2. Remove the cap, sipper, and filter, then pour any residual liquid into an appropriate receptacle.
3. Rinse the empty bottle with water. Pour out the rinse water into the same liquid waste receptacle.
4. Recycle or dispose of the clean bottle, cap, sipper, and filter according to applicable regulations.



Clean the Ion Chef™ System

■ About the cleaning protocol	57
■ Materials required	57
■ Clean the Ion Chef™ Instrument	57

About the cleaning protocol

The Ion Chef™ System includes an automated cleaning function that must be performed following every run. The cleaning routine is initiated from the Ion Chef™ Instrument touchscreen and is designed to minimize potential contamination. During the routine, the instrument irradiates the deck with ultraviolet light for 1 minute after all consumables have been removed from the instrument.

IMPORTANT! Although the Ion Chef™ Instrument cleaning routine provides some protection against contamination, it is not a substitute for good laboratory technique or precautions. When preparing DNA libraries for use or when preparing the Ion Chef™ Instrument, make certain to observe sterile laboratory procedures at all times to ensure minimal contamination.

Materials required

- Gloves, powder-free nitrile
- Isopropanol, 70% solution
- Wipes, lint-free

Clean the Ion Chef™ Instrument

IMPORTANT! Clean the Ion Chef™ Instrument as described in the following pages after every run. To prevent contamination, do not operate the instrument unless it has been recently cleaned.

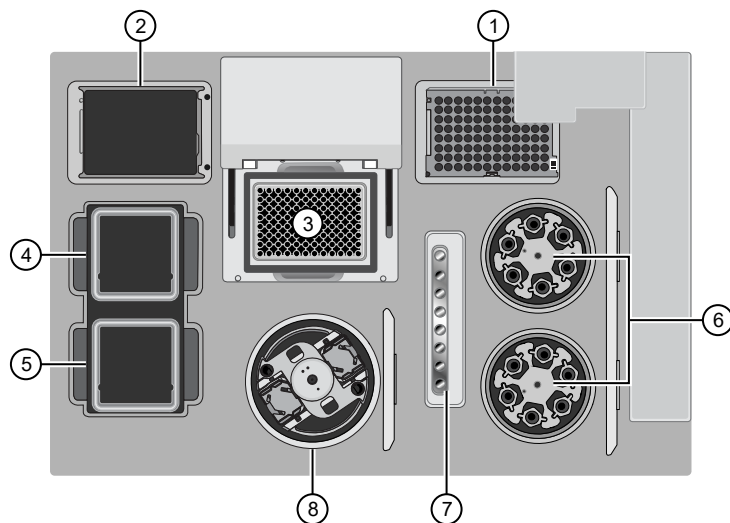

Ion Chef™ Instrument stations

- | | |
|---|---------------------------|
| ① Waste pipette tip position | ⑤ Solutions station |
| ② Empty Tip Cartridge v2: move to waste pipette tip station | ⑥ Recovery centrifuges |
| ③ Thermal cycler sample block | ⑦ Enrichment station |
| ④ Reagents station | ⑧ Chip-loading centrifuge |

Remove and dispose of used consumables

IMPORTANT!

- Do not discard the empty Tip Cartridge v2.
- Make sure to transfer the QC samples before you remove and discard the Reagents cartridge.

1. Tap  (**Open Door**) in the instrument touchscreen, then wait for the latch to open.
2. Lift the instrument door by the door handle to the top of the travel until the latch mechanism engages.

IMPORTANT! Lift the door from the center.

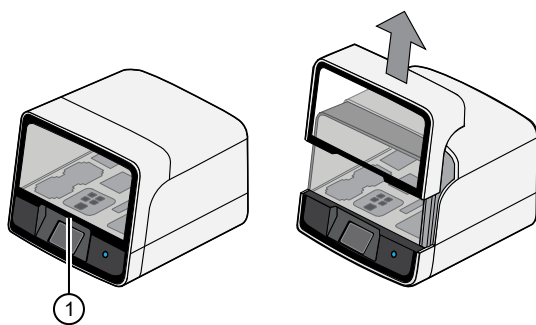

- ① Center of door

3. Remove, then discard the PCR Plate from the thermal cycler sample block.

4. Remove, then discard the box of used pipette tips from the waste tip position.

IMPORTANT! Handle the disposable reservoir in the waste tip position with care. During the run, liquid waste collects in the reservoir. Dispose of the liquid waste by tipping the reservoir on one corner and pouring the waste into an appropriate waste container:

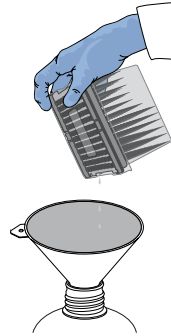

IMPORTANT! Do not reuse the waste pipette tip rack. Always move the empty Tip Cartridge v2 from the new tip position to the waste tip position.

5. Move the empty Tip Cartridge v2 to the waste tip position.
6. Remove, then discard the
 - Ion 510™ & Ion 520™ & Ion 530™ Chef Reagents cartridge
 - Ion S5™ Chef Solutions cartridge
 - Enrichment Cartridge v2
7. Remove, then discard the consumables from the Recovery centrifuges, including the:
 - Recovery Station Disposable Lid v2
 - Recovery Tubes v2
8. Close the Chip-loading centrifuge cover.

Inspect and clean the Recovery centrifuges and buckets

1. Inspect the Recovery centrifuges, then clean the components if excess liquid is present.

Is liquid present?	Action
No	Proceed to “Start the cleaning” on page 61.
Yes	Clean the centrifuge bowl and buckets as described below. IMPORTANT! Clean the Recovery centrifuges occasionally, only when excess liquid is noticeable in the bowl and/or buckets. You do <i>not</i> need to clean the centrifuges after every run.

IMPORTANT! Wear powder-free, nitrile gloves when cleaning the Recovery centrifuge.

- Remove the buckets from the Recovery centrifuges. Clean the inside and outside of each bucket using a lint-free wipe, then place the buckets on a clean, dry surface while you clean the centrifuge.

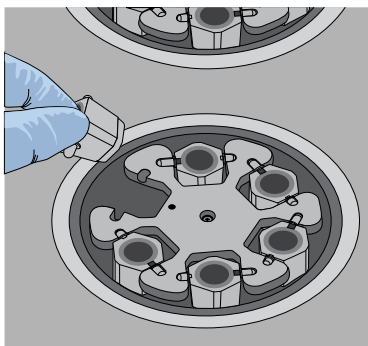

① Bucket

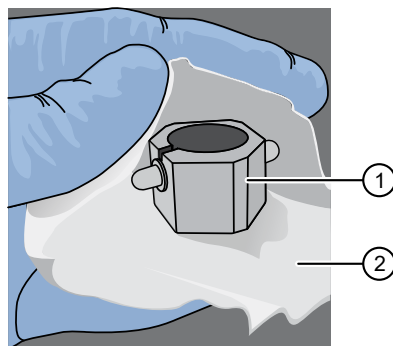

② Lint-free wipe

- Use lint-free wipes to remove all fluid from inside the centrifuge bowl.

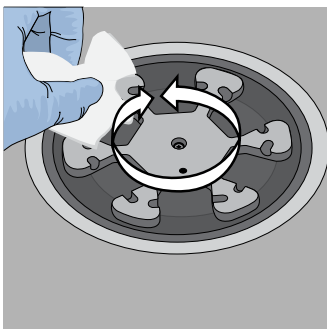

① Inside rim of the centrifuge

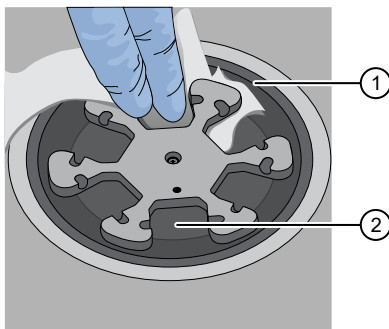

② Bottom of the centrifuge bowls

- Use lint-free wipes treated with 70% isopropanol to clean the following parts.
 - Inside rim of the centrifuge.
 - Bottom of the centrifuge bowl.
 - Outside and inside of the centrifuge buckets.

- Dry the centrifuge and buckets with lint-free wipes.

- Install the centrifuge buckets, then close the Recovery centrifuge cover.

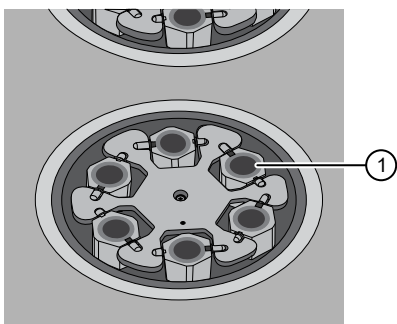

① Buckets (cleaned and installed)

Start the cleaning

1. Close the instrument door by first lifting it up slightly to disengage the locking mechanism, then pushing down on the door until the locks engage.

IMPORTANT! Before closing the door, ensure the covers of the Chip-loading and Recovery centrifuges are closed.

2. To start the cleaning, tap **Next** on the Ion Chef™ Instrument touchscreen that appears after run completion.



Note: You can also clean the instrument at any time starting from the home touchscreen. Tap **Settings** ▶ **Clean Ion Chef**.

3. Confirm that you have removed all consumables from the Ion Chef™ Instrument, except the empty pipette tip rack in the waste tip position, then tap **Next**.

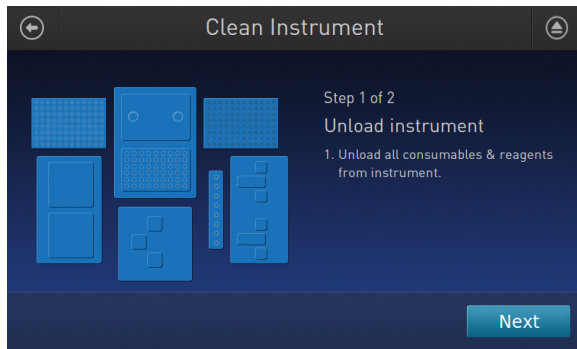

4. With the door closed, tap **Start**. The instrument performs a Deck Scan before starting the cleaning routine. The Ion Chef™ Instrument stops ventilation, then illuminates the ultraviolet (UV) light in the instrument for ~1 minute.

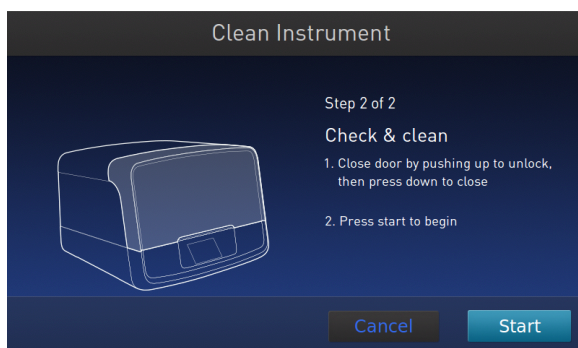

CAUTION! The Ion Chef™ Instrument emits UV light at 254 nm. Wear appropriate eye wear, protective clothing, and gloves when working near the instrument. Do not look directly at the UV light while it is illuminated during the cleaning routine.



Troubleshooting

- View troubleshooting and FAQs online 63
- Ion Chef™ System setup and operation 63
- Ion S5™/Ion GeneStudio™ S5 Systems setup and operation 66
- Ion Sphere™ Assay troubleshooting table 69

View troubleshooting and FAQs online

Visit our online Support Centers and FAQ database for tips and tricks for conducting your experiment, troubleshooting information, and FAQs. The online FAQ database is frequently updated to ensure accurate and thorough content.

- For the Next-Generation Sequencing Support Center: <http://thermofisher.com/ngssupport>
- For FAQs for this product: <http://thermofisher.com/A34461faqs>
- To browse the FAQ database and search using keywords: thermofisher.com/faqs

Ion Chef™ System setup and operation

Observation	Possible cause	Recommended action
Instrument does not display the home screen when powered on	Multiple causes are possible.	<ol style="list-style-type: none"> 1. Power off the instrument, wait 30 seconds, then power on the instrument. 2. If the instrument fails again, contact Technical Support.
The instrument door cannot be opened	An obstruction was present on or around the door mechanism.	Remove the obstruction blocking the door, then operate the instrument normally.
	A hardware or software error occurred.	Contact Technical Support to report the problem and for further assistance.
The instrument stops during a run	The instrument encountered an internal error.	<ol style="list-style-type: none"> 1. Record the error displayed on the instrument display, then tap OK. 2. Contact Technical Support to report the problem and for further assistance.
	A consumable was improperly loaded.	Ensure that all consumables are loaded according to the instructions provided.

Observation	Possible cause	Recommended action
Liquid residue is present in the Recovery centrifuges following a run	During normal instrument operation, a noticeable coating of liquid collected on the bowl and buckets of the Recovery centrifuges after repeated runs.	Remove the residue as instructed in “Inspect and clean the Recovery centrifuges and buckets” on page 59.
Instrument will not begin a run	The instrument has encountered a Deck Scan error (one or more consumables are absent or loaded improperly).	<ol style="list-style-type: none"> 1. Confirm that the touchscreen does not display any Deck Scan warnings. If alarms are present, note the error(s) displayed, replace the missing consumable as directed, tap No when prompted then tap Next to cancel the run. After returning to the home screen, restart the run. 2. If the error persists, confirm that: <ul style="list-style-type: none"> • All buckets are seated correctly in the rotors of the Recovery and Chip-Loading Centrifuges. • All cartridges are loaded correctly and are level on the instrument deck. • The barcodes of the Library Sample Tubes are visible and positioned correctly. • All tubes are both present <i>and</i> uncapped on the Ion 510™ & Ion 520™ & Ion 530™ Chef Reagents (sample tubes, NaOH tube, and the empty tube). 3. If the error persists after you check the consumables on the instrument deck, do one of the following: <ul style="list-style-type: none"> • If you are confident that the Ion Chef™ Instrument is set up correctly and you are comfortable disregarding the warnings, tap YES following Deck Scan to proceed with the run. • If the instrument cannot begin the run, contact Technical Support for further assistance.
	The instrument has encountered an internal error.	<ol style="list-style-type: none"> 1. Record the error displayed on the instrument display, then tap OK. 2. Contact Technical Support to report the problem and for further assistance.

Observation	Possible cause	Recommended action
Instrument displays one or more alerts during a run	The instrument detected one or more problems during the run.	After the instrument completes the run, contact Technical Support. If possible, capture an image of the alert or error message to help troubleshoot. IMPORTANT! The detected problem might impact the performance of the sequencing run.
	<ul style="list-style-type: none"> • Network connection to the server was interrupted. • User name or password was incorrect. 	<ol style="list-style-type: none"> 1. Tap the Instrument status button to view the alert(s). 2. In the Instrument status screen, confirm that the name of the Ion Torrent™ Server connection is red. 3. Contact your network administrator to confirm that: <ul style="list-style-type: none"> • The Ion Torrent™ Server can be accessed from the network port used by the Ion Chef™ Instrument. If not, troubleshoot the network connection. • The user name and password used by the Ion Chef™ Instrument are valid. If not, contact the server administrator to renew the credentials. 4. If the alert persists, capture an image of the alert or error message, if possible, to help troubleshoot, then contact Technical Support for further assistance.
Planned Run status does not advance to "Planned" Details: The status of a successfully completed run remains listed as "Reserved" in Torrent Suite™ Software.	Connectivity was temporarily lost or interrupted between the Ion Chef™ Instrument and Torrent Suite™ Software.	Manually change the status of the run to "Planned". <ol style="list-style-type: none"> 1. Sign in to the Torrent Suite™ Software. 2. In the Plan tab, click Planned Runs. 3. For the Planned Run of interest, click  ▶ Completed on Chef. The status changes to "Planned".

Ion S5™ /Ion GeneStudio™ S5 Systems setup and operation

Instrument alarms and events

Observation	Possible cause	Recommended action
<p>Red "Alarms" and/or "Events" message in Main Menu</p>  <p>The screenshot shows the Ion GeneStudio S5 main menu. At the top, it says 'Ion GeneStudio S5'. In the center, there is a large circular button labeled 'Initialize'. Below this, there are two icons: a red circle labeled 'Alarms' and a gear icon labeled 'Settings'. At the bottom, there is a status bar with various indicators: a signal strength icon, a battery icon, and several numerical values: -0.12 psi, 11.89 psi, 27.00 °C, 28.22 °C, 8%, and 19%.</p>	<ul style="list-style-type: none"> • Available software updates were detected. • Connectivity issues were detected. • Instrument did not detect required files or hardware. 	<p>Tap the red Alarms icon to see detailed messages.</p> <ul style="list-style-type: none"> • If a message states "Newer Software Available": <p>IMPORTANT! After updates are installed, the instrument must be restarted.</p> <ol style="list-style-type: none"> a. In the main menu, tap Settings ▶ Check for Updates. b. Select the Released Updates checkbox, then tap Update. c. When installation is complete, follow the onscreen prompts to restart the instrument. <p>Note: In some cases, the instrument restarts automatically after software installation.</p> • If a message states "No Connectivity to Torrent Server", "No Connectivity to ftp server", or "Network Manager not connected", disconnect and re-connect the ethernet cable, confirm that the router is operational, and verify that the network is up and running. • For any other messages: <ol style="list-style-type: none"> a. Power off the instrument: On the home screen, tap Settings ▶ System Tools ▶ Shut Down ▶ Shut Down. b. Wait 30 seconds, then press the button on the side of the instrument to power on the instrument. • If the red "Alarms" and/or "Events" message still appears in the main menu, contact Technical Support.

Initialization—General errors

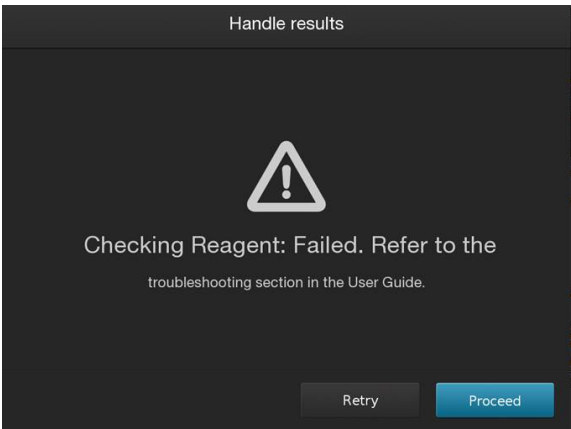
Observation	Possible cause	Recommended action
<p>Chip Check fails</p>	<ul style="list-style-type: none"> • The chip clamp was not closed. • The chip was not properly seated. • The chip was damaged. 	<ol style="list-style-type: none"> 1. Open the chip clamp, remove the chip, and look for signs of water outside the flow cell. 2. If the chip appears damaged, replace it with a new one. 3. Close the clamp, then repeat the Chip Check. 4. If the chip passes, click Next. If the chip fails, replace it with a new chip, then press Chip Check. 5. If Chip Check continues to fail, there could be a problem with the chip socket. Contact Technical Support.
<p>Reagent Check fails</p> 	<p>A chip failure was detected.</p>	<ol style="list-style-type: none"> 1. Replace the used sequencing chip used during initialization with a different used chip. IMPORTANT! If you are using Torrent Suite™ Software version 5.12.1 or earlier and if a used Ion 550™ Chip was used for initialization, replace the used chip with a used Ion 510™ Chip, Ion 520™ Chip, Ion 530™ Chip, or Ion 540™ Chip for the initialization. Using an Ion 550™ Chip causes an error. 2. Press Retry. 3. If the initialization completes without failure, touch Home, then continue with your sequencing run. 4. If the Reagent Check continues to fail, contact Technical Support.

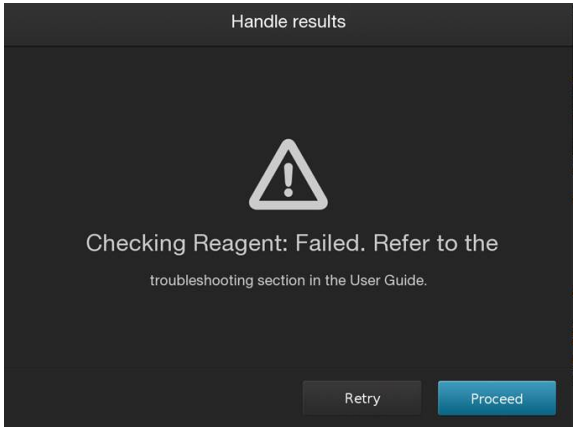
Observation	Possible cause	Recommended action
<p>Reagent Check fails</p>  <p>(continued)</p>	<p>A wash failure was detected.</p>	<ol style="list-style-type: none"> 1. Perform a manual cleaning of the sequencer, see “Perform a manual cleaning of the sequencer” on page 70. 2. Replace the Reagents cartridge, Wash Solution bottle, and Cleaning Solution bottle, then repeat initialization of the sequencer. 3. If the initialization completes without failure, press Home, then continue with your sequencing run. 4. If the Reagent Check continues to fail, contact Technical Support. <p>Ensure that you install the Ion S5™ Wash Solution bottle with the instrument door fully open. If you install the bottle impeded by a partially closed door, the port can be obstructed, and a faulty installation and wash failure can result.</p>
<p>Bottle leak check fails</p>	<ul style="list-style-type: none"> • Bottle seal was not tight. • Bottle was damaged or defective. 	<ol style="list-style-type: none"> 1. Finger-tighten the bottles. 2. If the bottle continues to leak, replace the bottle. 3. If leak check continues to fail, contact Technical Support.

Ion Sphere™ Assay troubleshooting table

The following table contains troubleshooting information for unenriched ISPs tested with the Ion Sphere™ Assay on a Qubit™ Fluorometer.

Note: Successful runs that meet chip throughput specifications have been performed with a lower percentage (5–10%) of templated ISPs. Use the following recommendations as guidelines only to titrate library input for optimal results, or troubleshoot problems with library preparation.

Qubit™ Fluorometer ^[1] observation	Ion S5™ /Ion GeneStudio™ S5 Systems observation	Possible cause	Recommended action
<10% Templated ISPs	<ul style="list-style-type: none"> • Lower loading • Lower % enriched • Lower key signal • Lower throughput 	Too little library input into template preparation.	<ul style="list-style-type: none"> • Increase library input to target 10–25% templated ISPs. <i>or</i> • Continue with sequencing; expect lower throughput.
>25% Templated ISPs, but <70%	Increased number of filtered out reads	Too much library input into template preparation.	<ul style="list-style-type: none"> • Decrease library input to target 10–25% templated ISPs. <i>or</i> • Continue with sequencing; expect lower throughput.
>70% Templated ISPs	<ul style="list-style-type: none"> • Increased % primer dimer filtered out reads • Lower throughput 	Adapter dimer contaminating library, more likely in short amplicon libraries, Ion AmpliSeq™ libraries, or miRNA libraries.	<ul style="list-style-type: none"> • Check Agilent™ 2100 Bioanalyzer™ traces for adapter dimer peak (Amplicon library or Ion AmpliSeq™ library peak around 70 bp; miRNA library peak around 60bp). • Re-purify library using Agencourt™ AMPure™ XP Kit clean-up steps as outlined in the appropriate user guides.
	<ul style="list-style-type: none"> • Low loading • Low % enriched • Lower throughput • High % filtered out reads 	Ion Chef™ System underperformance	Troubleshoot with Technical Support or a Field Application Scientist.

^[1] Qubit™ 2.0 Fluorometer or later.

- Perform a manual cleaning of the sequencer 70
- Perform an instrument reset run with an initialized sequencer that is loaded with an unused Reagents cartridge 71
- Quality control of Ion 510™ ISPs, Ion 520™ ISPs, or Ion 530™ ISPs 73
- Maintain the Ion Chef™ System 75

Perform a manual cleaning of the sequencer

A cleaning protocol is normally performed automatically at the completion of each sequencing run. If a cleaning is necessary, perform the following procedure.

1. On the home screen, select **Settings ▶ Clean Instrument**.
The instrument door unlocks allowing access to the consumables.
2. Remove the Ion S5™ Wash Solution bottle to access the waste reservoir, then remove and empty the waste reservoir.



3. Reinstall the empty waste reservoir and a *used* Ion S5™ Wash Solution bottle.
4. Ensure that the Ion S5™ Sequencing Reagents cartridge and Ion S5™ Wash Solution bottle are properly installed.

IMPORTANT! Perform the cleaning with a used reagent cartridge and wash solution bottle installed. The cleaning procedure pumps cleaning solution into the wash solution bottle and reagent cartridge making them unsuitable for sequencing.

5. Place a used sequencing chip in the chip clamp, then push the chip clamp in all the way to engage.
6. Close the instrument door, then tap **Next**.
Cleaning takes ~35 minutes to complete. On completion the instrument door automatically unlocks and the chip and cartridge clamps disengage.
7. Proceed to Chapter 5, "Initialize the sequencer".

Perform an instrument reset run with an initialized sequencer that is loaded with an unused Reagents cartridge

Cleaning is normally automatically performed at completion of a sequencing run. If an Ion S5™ Sequencer, Ion S5™ XL Sequencer, or Ion GeneStudio™ S5 Series Sequencer is initialized, an instrument reset run is required to ensure proper cleaning before reinitialization in one of the following situations.

- A sequencing run is not started within 24 hours after initialization.
- A sequencing run is not completed due to a power failure or an abort, and <200 flows occurred before the stoppage.

Do NOT perform a manual cleaning with an unused, initialized Ion S5™ Sequencing Reagents cartridge.

Note:

- If a power failure or abort occurs during the second of two runs started after a single initialization, a manual cleaning is sufficient (see "Perform a manual cleaning of the sequencer" on page 70).
- If the number of flows that occurred before a power failure or abort is unknown, perform an instrument reset run.

To perform an instrument reset run, use the following procedure before reinitialization.

1. In the instrument touchscreen main menu, tap **Run**.
The instrument door unlocks and the chip clamp disengages.
2. Ensure that a used sequencing chip is in the chip clamp, then push the chip clamp in all the way to engage.
3. Close the instrument door, then tap **Next**.
4. When prompted, select **Planned Run (none)**. Ensure that the **Enable post-run clean** checkbox is selected, then tap **Review**.
5. In the **Select Run** screen, tap **Edit**, then in the **Detail** screen set the number of flows to **200**. Ensure that the **Post-Run/Clean** checkbox is selected, then tap **Close**.
6. Tap **Start run**, then tap **Accept** to confirm that Post-Run Clean is enabled, and to start the run.



Appendix B Supplemental procedures

Perform an instrument reset run with an initialized sequencer that is loaded with an unused Reagents cartridge

When the instrument reset run completes, the instrument automatically performs the cleaning procedure. After cleaning, the touchscreen returns to the main menu.

Quality control of Ion 510™ ISPs, Ion 520™ ISPs, or Ion 530™ ISPs

Quality control using the Ion Sphere™ Assay on the Qubit™ Fluorometer

The Qubit™ Fluorometer can be used with the Ion Sphere™ Quality Control Kit (Cat. No. 4468656) to perform a quality assessment of unenriched Ion Sphere™ Particles generated for up to 400-base-read sequencing on an Ion S5™ Sequencer, Ion S5™ XL Sequencer, or Ion GeneStudio™ S5 Series Sequencer.

For detailed protocols, see the *Ion Sphere™ Quality Control Kit User Guide* (Pub. No. MAN0017531) available at thermofisher.com.

Note: This protocol supports the Qubit™ 2.0 Fluorometer or later.

Acceptance criteria for unenriched Ion 510™ ISPs, Ion 520™ ISPs, or Ion 530™ ISPs

The optimal amount of library corresponds to the library dilution point that gives Percent Templated ISPs between 10–25%.

Samples that fall within the recommended range generally produce the most data; however, samples that fall outside of the recommended range can still meet the throughput specifications on the Ion Chips™.

The recommended optimal range is not intended to be a pass/fail criterion. The range provides guidance for the quality of the sample.

Note: If the results are outside the desired Percent Templated ISPs range, then increase or decrease the library input appropriately. For more information, see the “Ion Sphere™ Assay troubleshooting table” on page 69.

Percent Templated ISPs	Description
<10%	Sample contains an insufficient number of templated ISPs to achieve optimal loading density on the Ion Chip™.
10–25%	Optimal amount of library.
>25%	Sample will yield multi-templated ISPs (mixed reads).

Quality control using the Guava™ easyCyte 5 Benchtop Flow Cytometer

The Guava™ easyCyte 5 Benchtop Flow Cytometer can be used for quality assessment of unenriched and enriched Ion Sphere™ Particles generated for up to 400-base-read sequencing on an Ion S5™ Sequencer, Ion S5™ XL Sequencer, or Ion GeneStudio™ S5 Series Sequencer.

- **Unenriched samples** – Obtain the QC samples from the corresponding Ion Chef™ Library Sample Tubes on the Ion 510™ & Ion 520™ & Ion 530™ Chef Reagents cartridge (positions A and B).
- **Enriched samples** – Obtain sample 1 from position E and sample 2 from position A on the Enrichment Cartridge v2.



Appendix B Supplemental procedures

Quality control of Ion 510™ ISPs, Ion 520™ ISPs, or Ion 530™ ISPs

For details, see the *Ion Sphere™ Particles Quality Assessment for the Ion Proton™ and Ion S5™ Systems Using the Guava™ easyCyte 5 Benchtop Flow Cytometer User Bulletin* (Pub. No. MAN0007496), available at thermofisher.com.

Maintain the Ion Chef™ System

For further information on the following Ion Chef™ System maintenance procedures, see the *Ion Chef™ Instrument User Guide* (Pub. No. MAN0018668), available at thermofisher.com.

- Install a firmware update
- Change the instrument name
- Replace the ultraviolet lamp
- Perform an XYθ calibration
- Perform a Z calibration

Note: You must install the Ion Chef™ Instrument firmware update in Torrent Suite™ Software 5.12 or later to access the XYθ calibration and Z calibration routines.



■ Symbols on this instrument	76
■ Location of safety labels on this instrument	78
■ Safety information for instruments not manufactured by Thermo Fisher Scientific	78
■ Instrument safety	78
■ Safety and electromagnetic compatibility (EMC) standards	79
■ Instrument safety – Ion S5™/Ion GeneStudio™ S5 Systems	81
■ Chemical safety	81
■ Biological hazard safety	82



WARNING! GENERAL SAFETY. Using this product in a manner not specified in the user documentation may result in personal injury or damage to the instrument or device. Ensure that anyone using this product has received instructions in general safety practices for laboratories and the safety information provided in this document.

- Before using an instrument or device, read and understand the safety information provided in the user documentation provided by the manufacturer of the instrument or device.
- Before handling chemicals, read and understand all applicable Safety Data Sheets (SDSs) and use appropriate personal protective equipment (gloves, gowns, eye protection, and so on). To obtain SDSs, see the “Documentation and Support” section in this document.

Symbols on this instrument

Symbols may be found on the instrument to warn against potential hazards or convey important safety information. In this document, the hazard symbol is used along with one of the following user attention words:

- **CAUTION!** – Indicates a potentially hazardous situation that, if not avoided, may result in minor or moderate injury. It may also be used to alert against unsafe practices.
- **WARNING!** – Indicates a potentially hazardous situation that, if not avoided, could result in death or serious injury.
- **DANGER!** – Indicates an imminently hazardous situation that, if not avoided, will result in death or serious injury.



Symbol	English	Français
	Caution, risk of danger Consult the manual for further safety information.	Attention, risque de danger Consulter le manuel pour d'autres renseignements de sécurité.
	Protective conductor terminal (main ground)	Borne de conducteur de protection (mise à la terre principale)
	Do not dispose of this product in unsorted municipal waste CAUTION! To minimize negative environmental impact from disposal of electronic waste, do not dispose of electronic waste in unsorted municipal waste. Follow local municipal waste ordinances for proper disposal provision and contact customer service for information about responsible disposal options.	Ne pas éliminer ce produit avec les déchets usuels non soumis au tri sélectif. MISE EN GARDE ! Pour minimiser les conséquences négatives sur l'environnement à la suite de l'élimination de déchets électroniques, ne pas éliminer ce déchet électronique avec les déchets usuels non soumis au tri sélectif. Se conformer aux ordonnances locales sur les déchets municipaux pour les dispositions d'élimination et communiquer avec le service à la clientèle pour des renseignements sur les options d'élimination responsable.

Conformity symbols

Conformity mark	Description
	Indicates conformity with safety requirements for Canada and U.S.A.
	Indicates conformity with European Union Low Voltage Directive 2006/95/EC, EMC Directive 2014/30/EU, and R&TTE Directive 1999/5/EC.
	Indicates conformity with Australian standards for electromagnetic compatibility.



Location of safety labels on this instrument

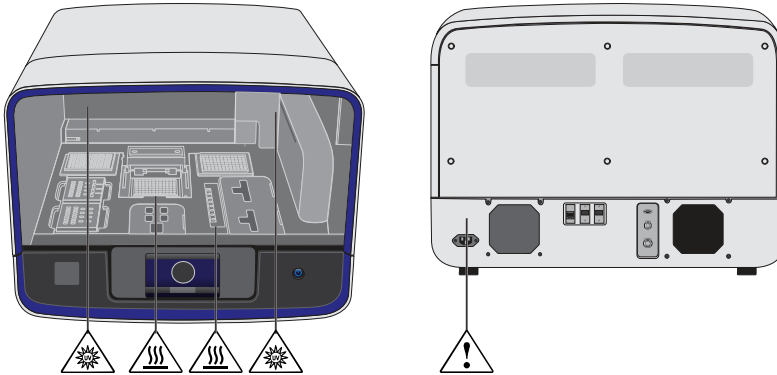

Safety information for instruments not manufactured by Thermo Fisher Scientific

Some of the accessories provided as part of the instrument system are not designed or built by Thermo Fisher Scientific. Consult the manufacturer's documentation for the information needed for the safe use of these products.

Instrument safety

General



CAUTION! Do not remove instrument protective covers. If you remove the protective instrument panels or disable interlock devices, you may be exposed to serious hazards including, but not limited to, severe electrical shock, laser exposure, crushing, or chemical exposure.

Physical injury



CAUTION! Moving Parts. Moving parts can crush, pinch and cut. Keep hands clear of moving parts while operating the instrument. Disconnect power before servicing.



Electrical safety



WARNING! Ensure appropriate electrical supply. For safe operation of the instrument:

- Plug the system into a properly grounded receptacle with adequate current capacity.
- Ensure the electrical supply is of suitable voltage.
- Never operate the instrument with the ground disconnected. Grounding continuity is required for safe operation of the instrument.



WARNING! Power Supply Line Cords. Use properly configured and approved line cords for the power supply in your facility.



WARNING! Disconnecting Power. To fully disconnect power either detach or unplug the power cord, positioning the instrument such that the power cord is accessible.

Cleaning and decontamination



CAUTION! Cleaning and Decontamination. Use only the cleaning and decontamination methods specified in the manufacturer's user documentation. It is the responsibility of the operator (or other responsible person) to ensure the following requirements are met:

- No decontamination or cleaning agents are used that could cause a HAZARD as a result of a reaction with parts of the equipment or with material contained in the equipment.
- The instrument is properly decontaminated a) if hazardous material is spilled onto or into the equipment, and/or b) prior to having the instrument serviced at your facility or sending the instrument for repair, maintenance, trade-in, disposal, or termination of a loan (decontamination forms may be requested from customer service).
- Before using any cleaning or decontamination methods (except those recommended by the manufacturer), users should confirm with the manufacturer that the proposed method will not damage the equipment.

Ultraviolet (UV) Safety

The Ion Chef™ System uses a UV lamp which emits light at 254 nm. Under normal operating conditions, the UV lamp is powered on when performing the cleaning protocol. Safety interlocks are used to ensure that the UV lamp is not powered when the door is open.

Safety and electromagnetic compatibility (EMC) standards

The instrument design and manufacture complies with the following standards and requirements for safety and electromagnetic compatibility.



Safety compliance

Reference	Description
EU Directive 2006/95/EC	European Union “Low Voltage Directive”
IEC 61010-1 EN 61010-1 UL 61010-1 CSA C22.2 No. 61010-1	<i>Safety requirements for electrical equipment for measurement, control, and laboratory use – Part 1: General requirements</i>
IEC 61010-2-010 EN 61010-2-010	<i>Safety requirements for electrical equipment for measurement, control and laboratory use – Part 2-010: Particular requirements for laboratory equipment for the heating of materials</i>
IEC/EN 61010-2-020	<i>Safety requirements for electrical equipment for measurement, control and laboratory use – Part 2-020: Particular requirements for laboratory centrifuges</i>
IEC 61010-2-081 EN 61010-2-081	<i>Safety requirements for electrical equipment for measurement, control and laboratory use – Part 2-081: Particular requirements for automatic and semi-automatic laboratory equipment for analysis and other purposes</i>

EMC

Reference	Description
Directive 2014/30/EU	European Union “EMC Directive”
FCC Part 15	U.S. Standard “Industrial, Scientific, and Medical Equipment”
AS/NZS 2064	<i>Limits and Methods of Measurement of Electromagnetic Disturbance Characteristics of Industrial, Scientific, and Medical (ISM) Radiofrequency Equipment</i>
ICES-001, Issue 3	<i>Industrial, Scientific and Medical (ISM) Radio Frequency Generators</i>
US FCC CFR Title 47 Part 15.225, Subpart C	<i>Operation within the band 13.110–14.010 MHz.</i>
Industry Canada RSS 210, Issue 8, Annex 2 EN 302 291-1/2 V1.1.1	<i>Licence-Exempt Radio Apparatus: Category I Equipment</i>

Environmental design

Reference	Description
Directive 2012/19/EU	European Union “WEEE Directive” – Waste electrical and electronic equipment
Directive 2011/65/EU	European Union “RoHS Directive” – Restriction of hazardous substances in electrical and electronic equipment



Instrument safety — Ion S5™/Ion GeneStudio™ S5 Systems

For detailed information on Ion S5™/Ion GeneStudio™ S5 Systems instrument safety symbols and alerts, safety and electromagnetic compatibility standards, and general instrument safety, see the Safety appendix of the *Ion S5™ and Ion S5™ XL Instrument User Guide* (Pub. No. MAN0010811), or the *Ion GeneStudio™ S5 Instrument User Guide* (Pub. No. MAN0017528), available at [thermofisher.com](https://www.thermofisher.com).

Chemical safety



WARNING! GENERAL CHEMICAL HANDLING. To minimize hazards, ensure laboratory personnel read and practice the general safety guidelines for chemical usage, storage, and waste provided below. Consult the relevant SDS for specific precautions and instructions:

- Read and understand the Safety Data Sheets (SDSs) provided by the chemical manufacturer before you store, handle, or work with any chemicals or hazardous materials. To obtain SDSs, see the “Documentation and Support” section in this document.
- Minimize contact with chemicals. Wear appropriate personal protective equipment when handling chemicals (for example, safety glasses, gloves, or protective clothing).
- Minimize the inhalation of chemicals. Do not leave chemical containers open. Use only with adequate ventilation (for example, fume hood).
- Check regularly for chemical leaks or spills. If a leak or spill occurs, follow the manufacturer's cleanup procedures as recommended in the SDS.
- Handle chemical wastes in a fume hood.
- Ensure use of primary and secondary waste containers. (A primary waste container holds the immediate waste. A secondary container contains spills or leaks from the primary container. Both containers must be compatible with the waste material and meet federal, state, and local requirements for container storage.)
- After emptying a waste container, seal it with the cap provided.
- Characterize (by analysis if necessary) the waste generated by the particular applications, reagents, and substrates used in your laboratory.
- Ensure that the waste is stored, transferred, transported, and disposed of according to all local, state/provincial, and/or national regulations.
- **IMPORTANT!** Radioactive or biohazardous materials may require special handling, and disposal limitations may apply.



Biological hazard safety



WARNING! BIOHAZARD. Biological samples such as tissues, body fluids, infectious agents, and blood of humans and other animals have the potential to transmit infectious diseases. Conduct all work in properly equipped facilities with the appropriate safety equipment (for example, physical containment devices). Safety equipment can also include items for personal protection, such as gloves, coats, gowns, shoe covers, boots, respirators, face shields, safety glasses, or goggles. Individuals should be trained according to applicable regulatory and company/ institution requirements before working with potentially biohazardous materials. Follow all applicable local, state/provincial, and/or national regulations. The following references provide general guidelines when handling biological samples in laboratory environment.

- U.S. Department of Health and Human Services, *Biosafety in Microbiological and Biomedical Laboratories (BMBL)*, 5th Edition, HHS Publication No. (CDC) 21-1112, Revised December 2009; found at:
<https://www.cdc.gov/labs/pdf/CDC-BiosafetymicrobiologicalBiomedicalLaboratories-2009-P.pdf>
- World Health Organization, *Laboratory Biosafety Manual*, 3rd Edition, WHO/CDS/CSR/LYO/2004.11; found at:
www.who.int/csr/resources/publications/biosafety/Biosafety7.pdf

Documentation and support

Related documentation

Document	Pub. No.
<i>Ion Chef™ Instrument User Guide</i>	MAN0018668
<i>Ion GeneStudio™ S5 Instrument User Guide</i>	MAN0017528
<i>Ion S5™ and Ion S5™ XL Instrument User Guide</i>	MAN0010811

Note: For additional documentation, see “Customer and technical support”.

Customer and technical support

Visit thermofisher.com/support for the latest service and support information.

- Worldwide contact telephone numbers
- Product support information
 - Product FAQs
 - Software, patches, and updates
 - Training for many applications and instruments
- Order and web support
- Product documentation
 - User guides, manuals, and protocols
 - Certificates of Analysis
 - Safety Data Sheets (SDSs; also known as MSDSs)

Note: For SDSs for reagents and chemicals from other manufacturers, contact the manufacturer.

Limited product warranty

Life Technologies Corporation and/or its affiliate(s) warrant their products as set forth in the Life Technologies' General Terms and Conditions of Sale at www.thermofisher.com/us/en/home/global/terms-and-conditions.html. If you have any questions, please contact Life Technologies at www.thermofisher.com/support.

