

City of Beaumont Driveway Construction and Maintenance

Driveway Maintenance

It is the responsibility of the abutting property owner to furnish all materials and labor necessary for the construction of driveways, sidewalks, and culverts.

Any existing driveway that is destroyed, altered, or removed as part of a city project will be replaced by the city.

All new or reconstructed driveway approaches shall consist of concrete or asphalt and must comply with the City of Beaumont regulations per City Ordinance Chapter 14, Article 3.

Right-of-Way Permits

A permit is required for:

- Any construction (installation and/or removal) in the public right-of-way.
- Construction on private property that will disturb more than 450-ft² requires a Grading Permit.

A permit is NOT required for:

- Construction on private property that will disturb less than 450-ft². However, please note that any hard surfaces such as concrete, asphalt, crushed rock, etc. must be offset at least 2-ft from interior property lines.

Permit Fees and Expiration:

- \$37 for Residential / \$77 for Commercial
- If work begins within six months, the permit is good for one year.
- Permits must be obtained by the property owner, lessee, or a bonded contractor representing the owner/lessee.

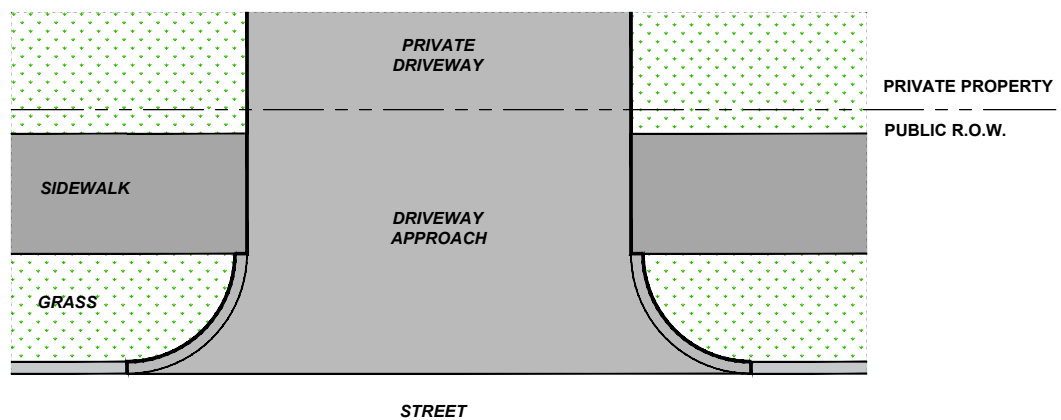

----- Right-of-Way Line

- The city owns the street and the property on each side. There is typically a joint at the R.O.W. line in existing driveways.

Construction Process Once Permit is Obtained

Culverts:

- The city's survey crew will set grades and verify pipe diameter, typically the following Friday.
- Set the culvert in place per City of Beaumont regulations.
- **CALL 311** to schedule a culvert inspection, prior to completely backfilling.
- A city inspector will verify pipe material, size, slope, and backfill.
- Upon approval, the remainder can be backfilled.

Note: Surface inlets are required every 50-ft of continuous pipe. The minimum pipe diameter is 18-in and shall be reinforced concrete pipe.

Driveways:

- Excavate the area, then place the formwork and reinforcement per City of Beaumont regulations.
- **CALL 311** to schedule an initial driveway inspection.
- A city inspector will verify driveway dimensions, placement, and reinforcement.
- Upon approval, the concrete can be poured.
- **CALL 311** to schedule a final driveway inspection.

Dimensional Requirements for Typical Driveways

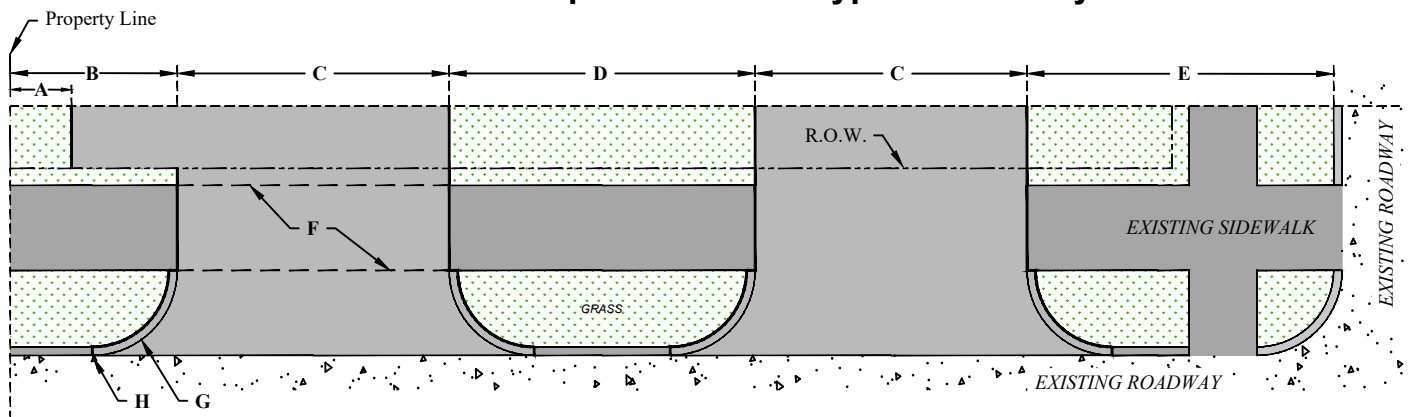

- | | |
|------------------------|--|
| A. 2' Offset | Pavement within private property shall have a minimum 2' offset from interior property lines. |
| B. 10' Offset | The edge of the driveway shall have a minimum 10' offset from the property line. |
| C. Max Width | 35' (<i>variances allowed for commercial businesses with vehicle bays.</i>) |
| Min Width | 10' (<i>residential</i>), 15' (<i>commercial, one-way traffic</i>), 20' (<i>commercial, two-way traffic</i>) |
| D. 20' | Adjacent driveways shall be a minimum of 20' apart. |
| E. 30' | Edge of driveway shall be a minimum of 30' from an intersection. |
| F. 2% Slope | The driveway section in line with an existing sidewalk shall have a max 2% cross-slope. |
| G. Min Radius | 5' (<i>residential</i>), 10' (<i>commercial</i>), 15' (<i>commercial, on arterial roads</i>) |
| H. Curb Tangent | The tangent point of the curb at the street curbline shall not extend beyond the property line. |

Note: All dimensions are minimum required values, unless otherwise noted.

Construction Specifications

Concrete Driveway Concrete Road

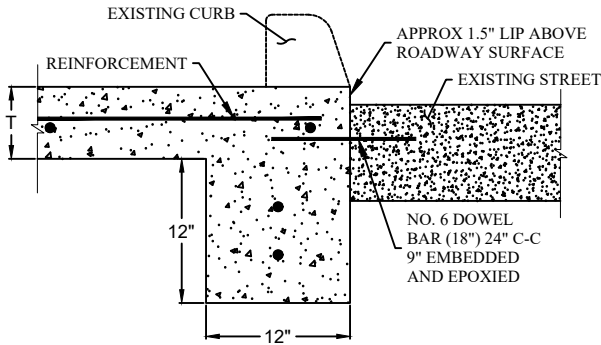

Concrete Driveway Asphalt Road

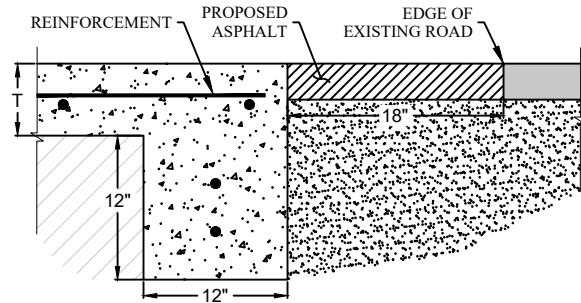

* Min. Driveway Thickness (T)
4" (Residential) / 6" (Commercial)

Asphalt Driveway Asphalt or Concrete Road

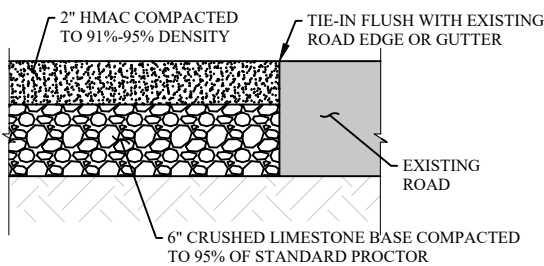

Typical Culvert Backfill Cross-Section

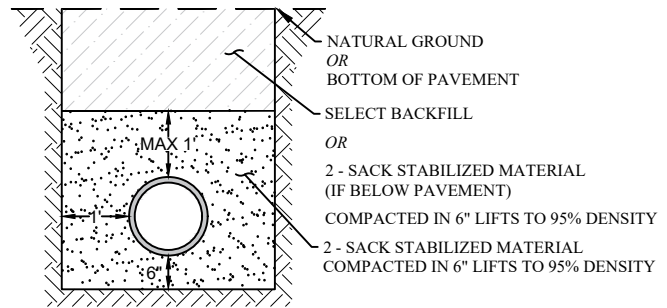

Plan View

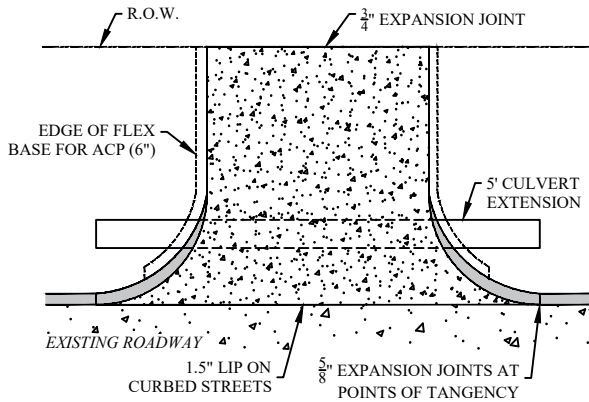

Construction Notes

1. Maximum slope of driveway is not to exceed 12%.
2. Reinforcement shall be No. 6 Wire Mesh or No. 4 Rebar at 12" C-C spacing.
3. Compact subgrade to 95% standard proctor.
4. Concrete shall have a strength of 3,000 psi in 28 days.
5. Expansion joints shall contain 18" x No. 4 smooth dowels with caps at 14" C-C (greased) with prefabricated joint material.
6. The interior angle formed by the extension of the axis of the driveway approach and the centerline of the street shall fall between 45° and 90°.
7. Property corners must be exposed prior to inspection.

Adjacent Sidewalk Detail

