



PATIENT/CAREGIVER INSTRUCTIONS

# Nasal CPAP/Bi-Level

To be used in conjunction  
with CPAP/Bi-Level  
equipment prescribed  
by physician, and  
product-specific  
operating manual.



Follow all warnings and instruction labels on  
medical devices.

To obtain a copy of the manufacturer's product manual,  
visit us at **apria.com**



## Table of Contents

Your Prescription .....	1
Importance of Resupply — Your Mask, Tubing and Headgear .....	1
Why Nasal CPAP/Bi-Level Therapy Is Needed .....	2
Your CPAP/Bi-Level Unit .....	3
Circuit .....	4
General Setup and Operation of CPAP/Bi-Level Unit and Accessories .....	5
Operating Your CPAP/Bi-Level Unit .....	5
Assembling Your Headgear and Mask Circuit .....	7
Final Assembly .....	9
Bi-Level Positive Airway Pressure .....	9
Using a Humidifier with Your System .....	10
Cleaning Your Humidifier .....	10
Using Oxygen with Your CPAP/ Bi-Level Unit .....	11
Cleaning Your Equipment .....	12
Cleaning the CPAP/Bi-Level Unit .....	12
Filter Maintenance .....	12
Information for Nasal CPAP Patients .....	13
Physical Problems .....	14
Handwashing Technique .....	14
Safety Precautions .....	14
Common Problems and Their Solutions ...	16
Troubleshooting .....	18
Feedback on Our Services .....	19

## Your Prescription

IPAP (inspiratory pressure): \_\_\_\_\_ cm H<sub>2</sub>O

EPAP (expiratory pressure): \_\_\_\_\_ cm H<sub>2</sub>O,  
if applicable

Back-up rate: \_\_\_\_\_ bpm, if applicable

CPAP unit: \_\_\_\_\_

Mask or pillow size: \_\_\_\_\_

Headgear: \_\_\_\_\_

Filters: \_\_\_\_\_

Ramp: \_\_\_\_\_

Humidifier:\* \_\_\_\_\_

Oxygen prescription: \_\_\_\_\_

\_\_\_\_\_

Prescription date: \_\_\_\_\_

Other: \_\_\_\_\_

\*A heated humidifier requires a physician's order.

Your CPAP/Bi-Level unit is a prescribed medical therapy unit that needs to be applied in a very specific manner. If your physician changes your CPAP/Bi-Level unit settings, notify Apria Healthcare immediately.

Please note that the information provided in this manual is intended to supplement, not replace, any special instructions provided by your physician.

## Importance of Resupply — Your Mask, Tubing and Headgear

Masks and supplies used with CPAP therapy generally tend to last three to six months. Some the factors that may impact how long the product can provide effective therapy include:

- Cushion seal deterioration
- Proper fitting and sizing at initial mask setup
- Frequency and method of mask cleaning



*Old equipment needs to be replaced regularly*

*"...there are high counts of bacterial and fungal flora on CPAP interfaces, despite routine washing, with the older interfaces, more contaminated and resistant to cleaning."\**

Regular ordering of fresh supplies is a critical part of maintaining your health and proper therapy.

At the time you received your CPAP/Bi-Level equipment, you received a form for enrolling in an auto-resupply program. Please complete this form and return it to the address printed at the bottom of the document. If your insurance allows it, Apria will ship your CPAP/Bi-Level supplies on an ongoing basis without your having to initiate the order. If your insurance doesn't allow you to participate in an auto-resupply program, you will receive automated reminder calls when it is time to re-order CPAP/Bi-Level supplies.

**Note:** If you did not receive or are unable to locate the auto-resupply form, please call the phone number on your

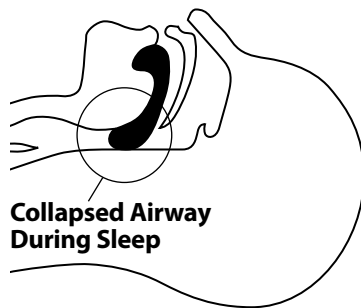

*Common sleep difficulty with Obstructive Sleep Apnea*

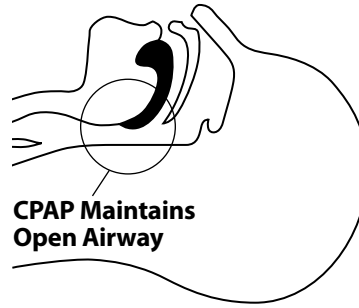

*Nasal CPAP acts to open upper airway*

Obstructive Sleep Apnea is a sleep disorder that occurs when the airway is obstructed or blocked. As a result, no air moves into or out of the lungs (this

Apria Service and Sales Agreement and an Apria representative will send the form to you.

## Additional Supplies

Your CPAP headgear and mask will wear out over time. To replace these items or to purchase additional supplies, call Apria Healthcare.

## Why Nasal CPAP/Bi-Level Therapy Is Needed

Both CPAP and Bi-Level therapies use Continuous Positive Airway Pressure (CPAP) to treat Obstructive Sleep Apnea (OSA).

## Common Signs and Symptoms of Obstructive Sleep Apnea

- Snoring
- Excessive daytime sleepiness
- Restless sleep (may include moving arms and legs)
- Morning headaches
- Slight disorientation/memory lapses
- Irritability
- Personality changes
- Pauses when the patient doesn't breathe during sleep

\*Horowitz S, SLEEP, Volume 32, Supplement, 2009 #0634.

is called “apnea”). The obstruction may be due to a variety of factors including loss of muscle control over the tongue which may cause the tongue to fall back against the airway and/or the collapse of the soft palate (the soft part of the roof of the mouth) over the airway.

You breathe differently during sleep and wakefulness. During sleep, your muscles relax, your airway narrows and your body exerts less effort to breathe. During an episode of apnea, the brain causes you to awaken slightly without even realizing it so that you can breathe. Episodes of apnea can last from just a few seconds to over a minute and can occur hundreds of times throughout the night. With each breath, oxygen should be brought into the lungs, absorbed into the blood, and then distributed to the organs and tissues. Also, carbon dioxide should be exhaled. During apnea episodes, the oxygen content of the blood decreases and carbon dioxide levels increase. This causes the blood pressure to rise, which puts stress on the heart and other organs. Also, this constant interruption of deep sleep results in a loss of restful, healthy sleep, and generally causes daytime sleepiness.

The CPAP/Bi-Level unit treats Obstructive Sleep Apnea by providing low pressure airflow to your airways by means of a nasal mask that fits over the nose or nasal pillows which are inserted into the nostrils. Air pressure holds the airway open,

preventing the collapse of the palate and tongue over the air passage. This allows for normal breathing and uninterrupted sleep.

## Your CPAP/Bi-Level Unit

**Note:** Your unit may look different than the units pictured in this booklet.

The CPAP and Bi-Level units use electrically powered motors and blowers to maintain the air flow necessary for treatment. As room air enters the unit it is filtered for dust and other airborne particles, then pushed through the circuit and into your airways.

Your physician has prescribed the appropriate level of air pressure to keep your airway open during sleep. **Do not make any adjustments to your CPAP or Bi-Level unit.** If you have any questions about your prescribed setting, please consult your physician or Apria Healthcare.

CPAP and Bi-Level units are available in different models. However, all models have the same basic parts: a **power switch** to turn the unit on and off; an **air outlet** to which the tubing is connected; and an **air inlet** where air

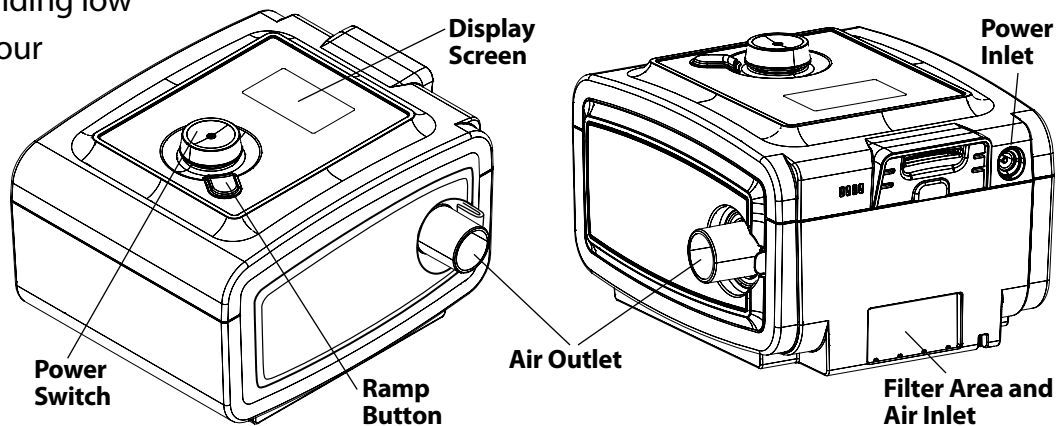

Basic parts of CPAP/Bi-Level units

is pulled into the unit through a **filter(s)** which removes dust and lint from incoming air.

## Ramp Feature

Some units are equipped with a feature called ramp. The ramp feature allows you to reduce the air pressure to a very low level as you begin to fall asleep. Within 45 minutes, the pressure will automatically “ramp up” to your prescription pressure at a gentle rate that should not awaken you. Some units allow you to set your ramp time. Your manufacturer’s user manual includes information regarding your specific device’s ramp features.

## Circuit

The circuit is attached to the air outlet on the CPAP/Bi-Level unit. The circuit has a number of parts. These parts vary depending upon the type of circuit used: **nasal pillow circuit** or **nasal mask circuit**.

## Nasal Pillow Circuit

If you are using a nasal pillow circuit, you will need the following items: **tubing**, which attaches to the air outlet on the CPAP/Bi-Level unit; a **shell** to which the nasal pillows are attached; **nasal pillows** which fit snugly in the nostrils; and **nasal pillow headgear** which secures the

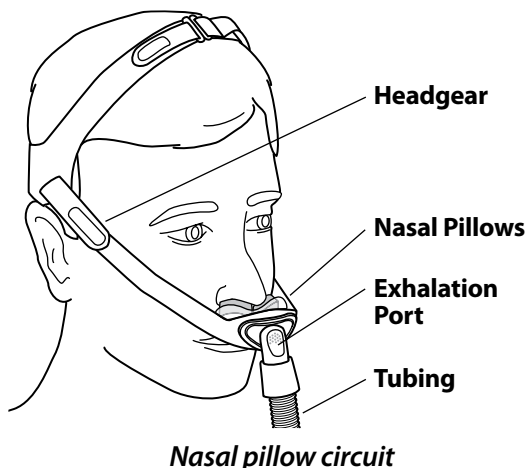

nasal pillows to the nose and maintains a proper seal in both nostrils.

## Nasal Mask Circuit

If you are using a nasal mask circuit, you will need the following items: **tubing**, which attaches to the air outlet on the CPAP/Bi-Level unit; a **nasal mask**, which fits snugly over the nose; and **nasal mask headgear** which secures the nasal mask to the face.

## Full Face Mask

Your physician may have prescribed a full face mask. This is a mask that covers both the nose and mouth. The mask includes a **quick release tab** that allows the mask to be taken off quickly in the event of an emergency.

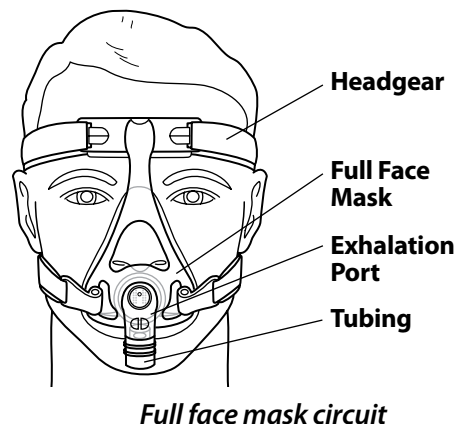
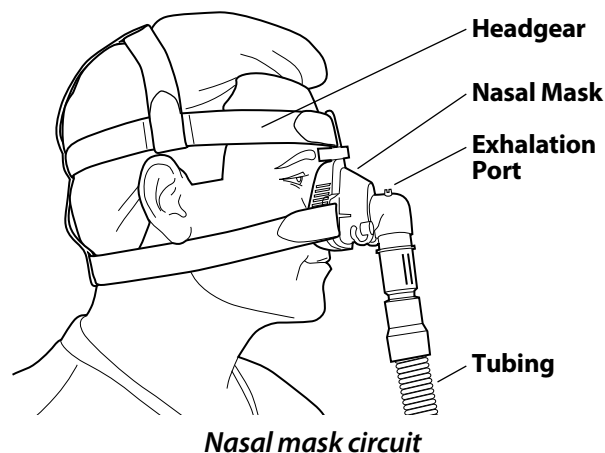



## Exhalation Ports

Both nasal shells and nasal masks must provide an opening to allow exhaled air to escape. **Do not block the exhalation ports or vents.**

## General Setup and Operation of CPAP/Bi-Level Unit and Accessories

Below are the general steps for setting up and operating your CPAP/Bi-Level unit. Your Apria Licensed Professional has set your CPAP/Bi-Level to the prescribed settings which were provided by your physician. More detail is included on the pages referenced and following this overview as well as within the manufacturer's user manual.

1. Place your CPAP/Bi-Level unit on a sturdy surface. (Page 5)
2. Insert the power plug into a power outlet. (If the power plug is not permanently attached to your unit, attach the other end of the cord to the CPAP/Bi-Level unit.) (Page 6)
3. If you have a humidifier, continue the following steps (Page 10) (If you do not have a humidifier, proceed to Step 4):
  - a. Fill the humidifier reservoir with distilled water.
  - b. Connect one end of the short humidifier tube to the air outlet on the CPAP/Bi-Level unit and the other end to the inlet port on the humidifier reservoir.
  - c. Connect your large bore tubing to air outlet on your humidifier
  - d. Proceed to Step 5.

4. Connect your large bore tubing to the air outlet on the CPAP/Bi-Level unit. (Page 6)
5. Assemble your headgear and mask circuit. (Pages 7–8)
6. Place the mask/ headgear on your head. (Pages 7–8)
7. Connect your headgear and mask circuit to your tubing and CPAP/Bi-Level unit. (Page 9)
8. Turn the power switch on your CPAP/Bi-Level unit to ON. (Page 9)
9. If applicable, adjust the ramp feature. (Page 9)
10. Relax and take slow breaths through your nose. The machine will automatically deliver your prescribed pressure level. (Page 9)
11. If you are experiencing air leaking out of your mask or nasal pillows, adjust your mask. (Pages 7–8)

**Note:** If you are using oxygen with your CPAP/Bi-Level unit, follow the instructions for proper assembly in your manufacturer's user manual and refer to page 11 of this manual.

## Operating Your CPAP/Bi-Level Unit

The following step-by-step instructions will help you operate your unit.

**Step 1:** Place the CPAP/Bi-Level unit on a sturdy surface.

- Select a location near the bedside, such as a nightstand or dresser. Please refer to the manufacturer's user manual



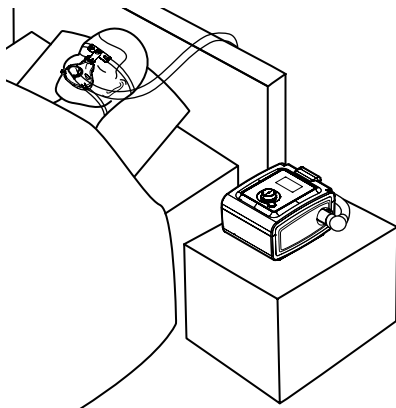

Place unit on a sturdy surface

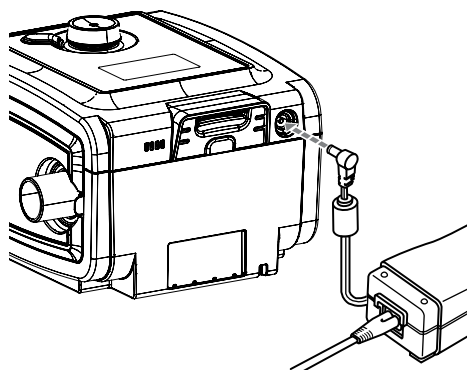

Plug power cord into the power inlet, if cord is not permanently attached

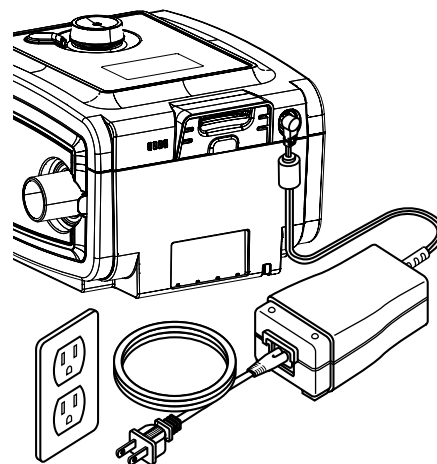

Plug unit into a wall outlet

for recommended CPAP/Bi-Level and tubing placement.

- Make certain that the air inlet is not blocked by bedclothes, draperies or furniture.
- Do not place the unit near a heat source.
- Do not place the unit on a pad or carpet that could obstruct the flow of air around or underneath the unit.

**Step 2:** Insert the power plug into a nearby power outlet.

**Note: Most Apria CPAP/Bi-Level units use “2-prong” power plugs and do not require a 3-prong, grounded AC power outlet.**

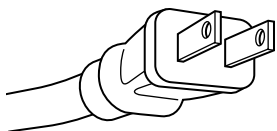

Two-prong power plug

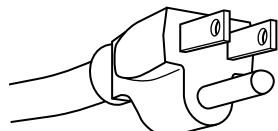

Three-prong (grounded) power plug

However, if the unit that has been provided to you has a 3-prong power plug and your home does not have 3-prong power outlets, contact Apria and we will exchange your CPAP/Bi-Level for a unit that utilizes the 2-prong plug.

**Step 3:** If the AC power cord is not permanently attached to your unit, plug its female end into the AC power inlet

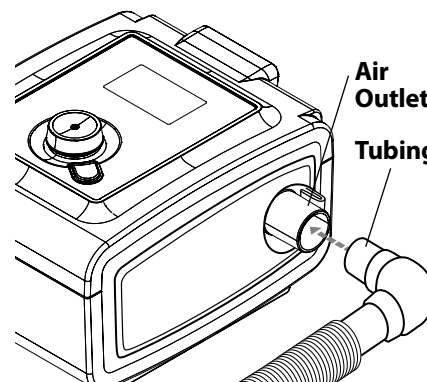

Connect the tubing

on the back of the unit. Plug the other end of the cord into an appropriate (as described in Step 2) electrical power outlet.

- Do not use an extension cord with your unit.
- Do not plug the unit into an outlet that has other major appliances plugged into it.

**Step 4:** Connect your tubing to the air outlet on the CPAP/Bi-Level unit.

**Step 5:** Assemble and fit your nasal mask or nasal pillow circuit as instructed on the following pages. Keep the unit turned OFF until you have completely put on and secured the nasal mask or nasal pillows and headgear.

## Assembling Your Headgear and Mask Circuit

### Nasal Mask Circuit

Follow these instructions for assembling and fitting the **nasal mask circuit**:

**Step 1:** Arrange the headgear so the longer straps are at the top.

**Step 2:** With the Velcro facing out, away from your face, thread the four tabs through the top and side slots of the mask. Pull the straps through and fasten by pressing the Velcro back against the strap.

**Step 3:** Place the mask over your nose and slide the headgear over your head.

**Note:** There are several options to make your mask more comfortable. A spacer may be necessary to relieve irritation on the bridge of the nose. Ask your Apria Healthcare representative for more information.

**Step 4:** Adjust all the Velcro straps, gradually tightening them until the mask fits comfortably against the face.

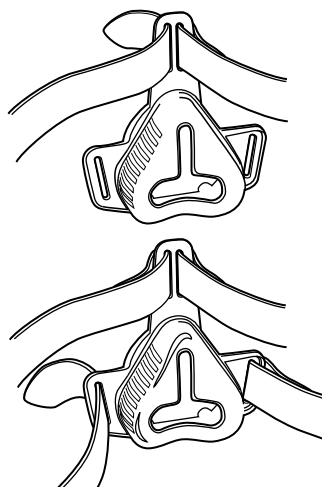

*Fitting the mask*

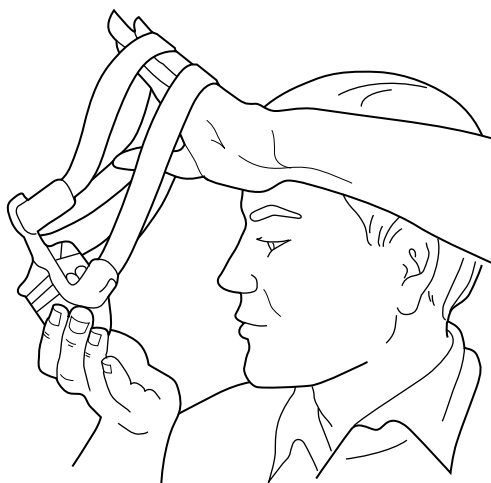

*Putting on the mask*

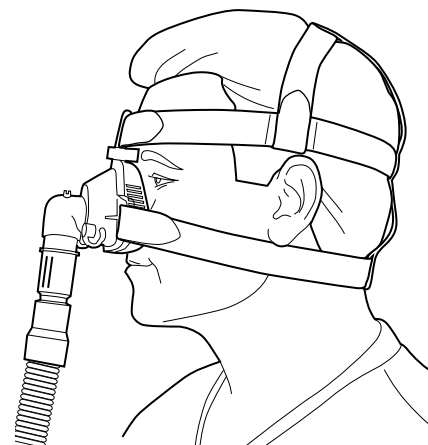

*Correctly adjusted mask*

A tighter fit is not necessarily better — it can be loose as long as the seal is maintained.

**Do not block the exhalation port on your nasal mask circuit.** The exhalation port may be located at the base of your mask or in a special attachment between your mask and tubing.

### Helpful Hints

- For ease in future adjustments, you may wish to use permanent ink to mark the straps at the final strap position.
- Washing your face to remove excess facial oils will help to achieve a leak-free fit and prolong the useful life of the mask.

### Nasal Pillow Circuit

Follow these instructions for assembling and fitting the **nasal pillow circuit**:

**Step 1:** Before putting on the mask, place the pillow cushion tips under your nostrils. Choose the cushion size that sits comfortably under your nose without any gaps.

**Important:** Do not push the pillows gel base into your nostrils.

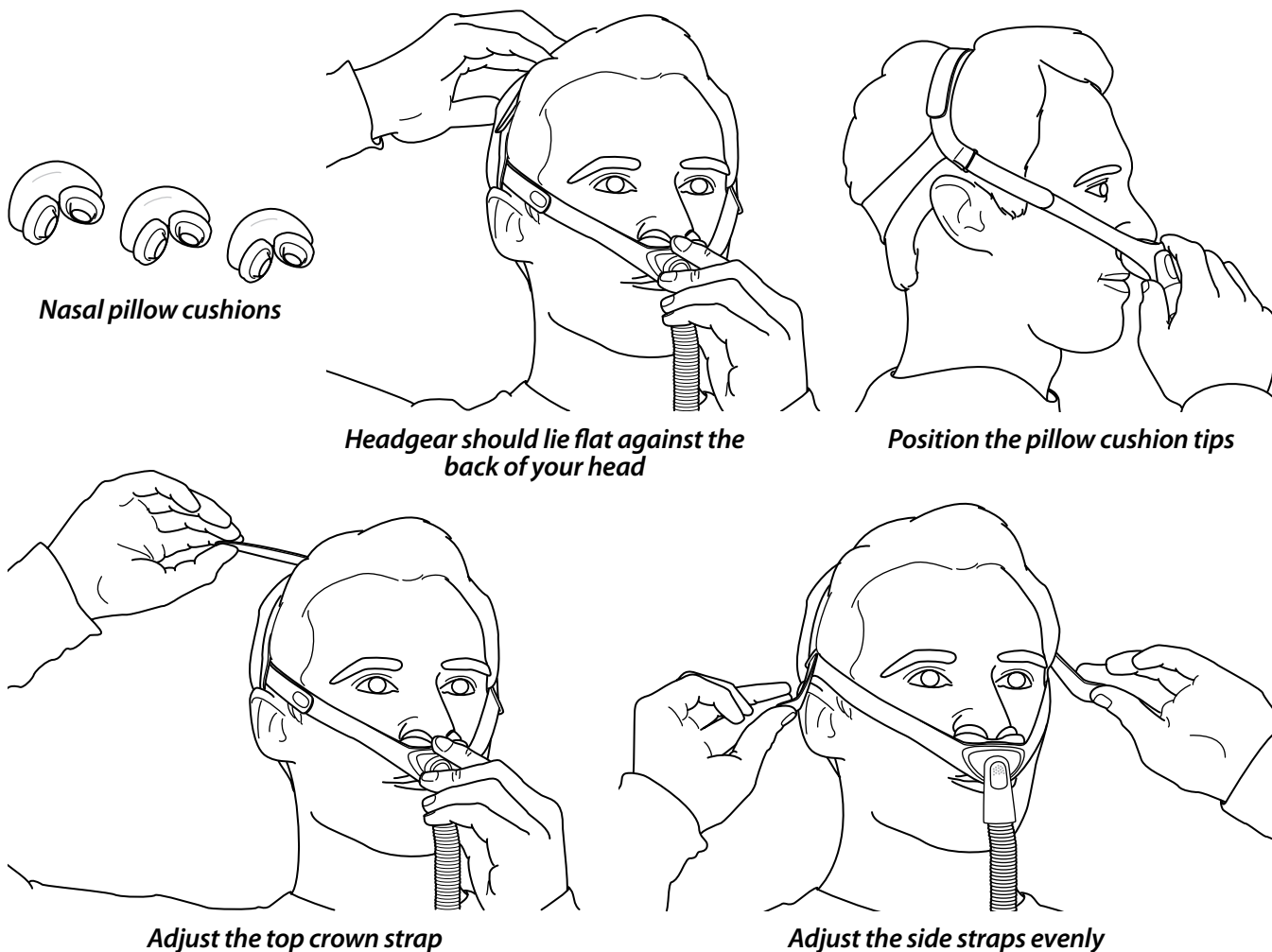

**Step 2:** Pulling the headgear over your head, gently hold the pillows cushion under your nose. The headgear should lie flat against the back of your head.

**Step 3:** Position the pillow cushion tips into your nostrils so that they sit comfortably under your nose without any gaps.

**Step 4:** Adjust the top crown strap so that the headgear sits just above your ears and is not too close to your eyes. The headgear should fit loosely and feel comfortable.

**Step 5:** Adjust the side straps evenly by pulling downwards;

the mask should feel secure and comfortable against your face. Do not over tighten.

**Step 6:** Final adjustments for comfort and seal should be made while lying down with your device pressure applied.

**Note:** If excessive leaks persist, try an alternate cushion size.

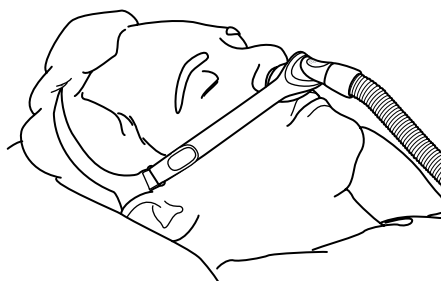

*Make final adjustments while lying down*

**Do not block the exhalation port on your nasal pillow circuit.** Your exhalation port is located on the backside of the shell holding the nasal pillow cushions.

## Final Assembly

Follow these steps to **connect the circuit to your CPAP or Bi-Level unit**:

**Step 1:** Connect the tubing to your nasal mask.

- If you are using a nasal pillow circuit, your tubing is already attached.
- Adjust the tubing so that it will not pull on the mask or nasal pillow circuit when you lie down.
- If possible, route the tubing up and over your headboard to reduce the tension on your mask or nasal pillow circuit.

**Step 2:** Press the power switch to ON.

The unit will automatically deliver your prescribed pressure level.

Make sure that no air is leaking out of your mask or nasal pillows. If it is, readjust your mask or nasal pillows and headgear.

**Step 3:** If prescribed or if you have chosen to use the **ramp feature**, you may activate the ramp dial or delay button at this time. Either press the **delay button** which will activate the ramp feature over a set period of time or turn the **ramp dial** to the amount of time you desire.

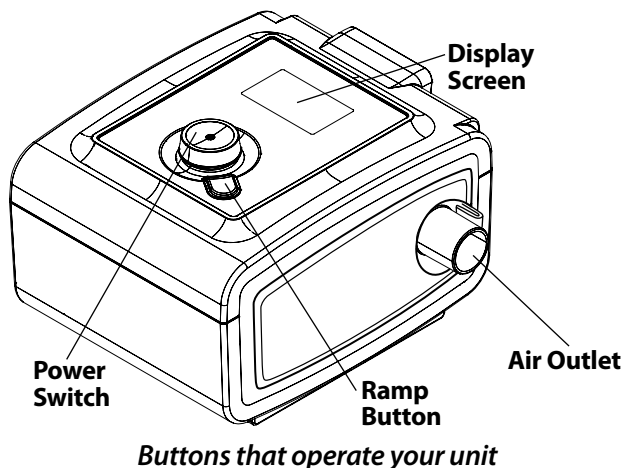

**Step 4:** Relax and take slow deep breaths through your nose.

If you need to get up during the night, press the power switch to OFF and disconnect the tubing from the nasal mask or nasal pillow assembly, leaving the mask or nasal pillows and headgear on your head. Reattach the tubing when you return to bed and press the power switch to ON. You may wish to reactivate the ramp feature if it is available on your unit.

If you wish to remove the headgear and mask or nasal pillows, it may be easiest to unhook or loosen only one of the bottom straps to remove the headgear in a quick one-step fashion.

**Step 5:** In the morning, clean your mask or pillows (see page 12). Daily cleaning is recommended.

## Bi-Level Positive Airway Pressure

Some patients may require a Bi-Level unit. Standard CPAP units maintain the same pressure while you inhale and exhale. A Bi-Level unit has a higher pressure for inhalation and a lower pressure for exhalation. Many patients report that the Bi-Level unit's lower expiratory



pressure makes it easier for them to exhale, so they feel more comfortable.

As with the standard CPAP unit, the pressure settings **must** be ordered by your physician, and should not be changed without your physician's approval.

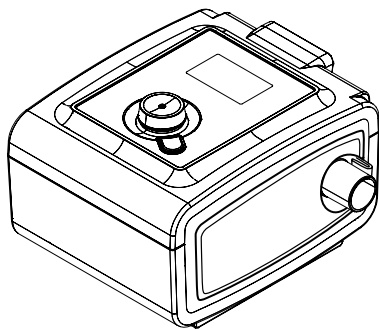

*Typical Bi-Level positive airway pressure unit*

## Using a Humidifier with Your System

If you are bothered by nasal problems for more than a week or two, your physician may prescribe the use of a humidifier during CPAP or Bi-Level therapy. The humidifier adds moisture to the air delivered by the unit. Although humidifier units may vary, most function in the same manner. Follow these basic instructions for **humidifier use**:

**Step 1:** Fill the humidifier reservoir using distilled water. Fill the water only to the **fill line**.

- Keep the unit turned OFF until the humidifier is properly connected and you are ready to use your unit.

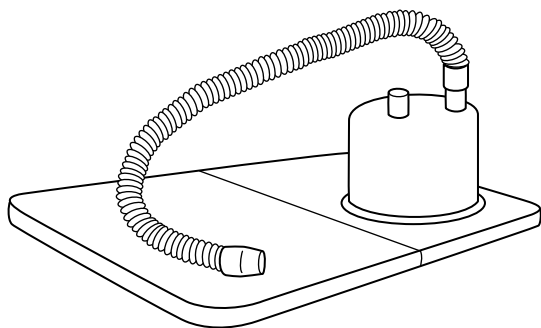

*Cool humidifier with stand*



*CPAP system with integrated heated humidifier*

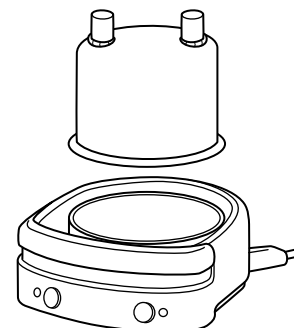

*Heated humidifier base and chamber*

- Do not use medications in the water reservoir.
- To prevent electrical hazard, do not allow water to come into contact with any part of the unit other than the water reservoir.

**Step 2:** Connect the short humidifier tube to the air outlet on the unit and the inlet port on the humidifier reservoir. Refer to your specific device's manufacturer's user manual.

**Step 3:** Connect the patient tubing to the outlet port on the humidifier reservoir.

**Step 4:** Clean humidifier reservoir as instructed below.

**Note:** Your physician may have prescribed a heated humidifier for use with your CPAP or Bi-Level unit. Refer to your specific device's manufacturer's user manual for specific information regarding the humidifier provided to you.

## Cleaning Your Humidifier

**Note:** If you have a heated humidifier, immerse only the humidifier jar in water or disinfectant. Never immerse electrical appliances in any liquid.

## Daily Cleaning

**Step 1:** Empty any remaining water out of the reservoir after each use.

**Step 2:** Wash your hands as instructed on page 14.

**Step 3:** Immerse the humidifier in warm, soapy water. Fill the humidifier with the soapy water and shake vigorously.

**Step 4:** Rinse with clean water and allow to air dry.

## Using Oxygen with Your CPAP/ Bi-Level Unit

If your physician has prescribed oxygen for you to breathe during CPAP or Bi-Level therapy, you must also learn how to use and care for an oxygen system. It is important to observe all fire and safety rules associated with the use of oxygen. If you have any questions about the use and care of an oxygen system, contact Apria Healthcare.

Oxygen tubing may be connected to the unit by using an **oxygen tee adapter** or a **port** on the nasal mask.

If your oxygen is administered with a tee adapter, the adapter may be connected to the air outlet on the unit or between the tubing and nasal mask.

Your tubing is connected to the large end on the tee adapter and the small tubing from your oxygen system is connected to the small nipple on the tee adapter.

- **Always turn your CPAP or Bi-Level unit ON before turning ON the oxygen flow.**
- **Always turn OFF the oxygen before turning OFF the CPAP or Bi-Level unit.**

Your oxygen may be administered through a port on the nasal mask. Keep the ports closed unless using oxygen. The small tubing from your oxygen system is directly connected to the port on your nasal mask. Refer to your specific device manufacturer's user manual for information regarding proper placement of oxygen.

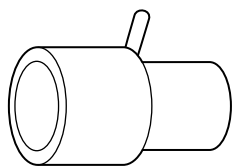

Oxygen tee adapter

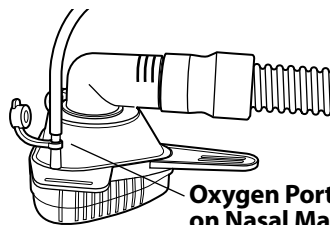

Oxygen Port on Nasal Mask

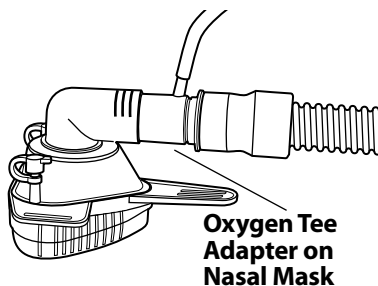

Oxygen Tee Adapter on Nasal Mask

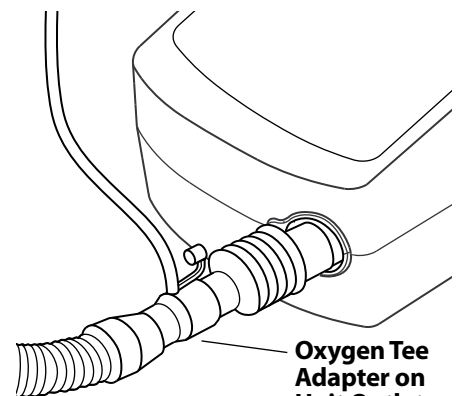

Oxygen Tee Adapter on Unit Outlet

*Several types of oxygen connections*



## Cleaning Your Equipment

### Daily Cleaning Procedures

To lengthen the life of your equipment and supplies, it is important to inspect and clean all components regularly. The masks, tubing and headgear should last approximately 3 to 6 months, but the actual life of the equipment can vary considerably. Inspect all components daily and clean them as necessary. Daily cleaning is recommended for CPAP masks; other supplies should be cleaned according to the manufacturer's instructions.

**Caution: Do NOT clean any parts of the system with alcohol, cleaning solutions containing alcohol, bleach or any strong household cleansers.**

Follow these procedures for cleaning your CPAP or Bi-Level equipment:

**Step 1:** Wash your hands as instructed on page 14.

**Step 2:** Remove the headgear from the mask or nasal pillows shell. Disconnect the mask or shell (remove the pillows from the shell), swivel connector and tubing.

**Step 3:** With a soft cloth, gently wash the mask or pillows with a solution of warm water and a mild, clear liquid detergent.

**Step 4:** Rinse thoroughly. If the mask still feels oily, repeat step 3.

**Step 5:** Allow the mask or pillows to air dry. Do not place any supplies in the dryer.

## Cleaning the CPAP/Bi-Level Unit

### Clean Your Unit as Necessary

**Step 1:** Unplug the unit before cleaning it. **Never immerse the unit in water.**

**Step 2:** Using a damp cloth, wipe the outside of the unit.

**Step 3:** Use a dry cloth to wipe the unit dry.

**Step 4:** Make sure the unit is thoroughly dry before plugging it in again.

### Filter Maintenance

Filter maintenance will depend on the model of unit you have. There may be two filters on some models. The first filter is usually disposable and the second filter is reusable.

Please review the manufacturer's product literature for specific filter maintenance instructions. If you have any questions, call Apria Healthcare.

**Never place a damp filter in your CPAP or Bi-Level unit.**

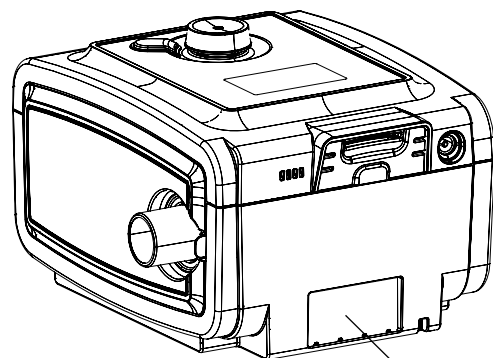

Filter Area

*Filter maintenance depends on which model you have*



---

## Information for Nasal CPAP Patients

The nasal CPAP unit provides a treatment for your sleep disorder and should be used every night (and/or anytime that you sleep).

1. Since your sleep is now deeper and more restful than before, you may not need to sleep as many hours to feel rested.
2. Try to go to bed and get up about the same time every day. This will help your body to establish a regular sleep/wake cycle.
3. CPAP or Bi-Level therapy may help to lower blood pressure in patients who have hypertension. If you are on blood pressure medicine, make sure all of your physicians know that you are using a CPAP or Bi-Level unit. Never change your blood pressure medication without your physician's approval.
4. After a week or two of using your CPAP or Bi-Level unit, you should not be sleepy during the day.
5. Your snoring should be reduced or eliminated when you use your CPAP or Bi-Level unit. If a family member notices that you are beginning to snore loudly again while wearing the unit, inform your physician. You may need an adjustment to your CPAP pressure.
6. During the first few weeks of treatment you may experience some sneezing and perhaps a sensation of nasal obstruction. This is normal. Nasal

congestion is the most common side effect of CPAP therapy. A common cause of nasal congestion is the drying and cooling of the upper airway by your CPAP device. This is responsible for the feeling of dryness in the throat or nose. Many times this will resolve itself as you become accustomed to your CPAP unit. It may take up to four weeks.

7. The CPAP machine is designed to eliminate the interruptions of your respirations during sleep at your current weight. However, if you are overweight, weight loss generally will improve your overall health and could allow your physician to decrease the pressure of air used in your machine. (In some cases, weight loss may enable your physician to discontinue the use of the unit altogether.) If you gain weight, your physician may need to increase the pressure of your CPAP unit. If you experience weight loss or gain, please contact your physician.
8. If you require surgery or hospitalization for any reason, make sure you inform your surgeon, physician and/or hospital staff of your diagnosis and the need to use the CPAP unit with all sleep. Please take your CPAP unit to the hospital so that you can use it during your hospitalization, especially when you are sedated before and after surgery.

You should be able to use the CPAP unit all night long, every night. If, after trying these suggestions, you cannot sleep through the night, please contact your physician.

## Physical Problems

If you experience any **physical problems**, call your physician.

If you are having trouble with your **equipment**, call Apria Healthcare.

If you experience **severe physical problems**, call 911.

## Handwashing Technique

Thorough handwashing must be done prior to all procedures. Contaminated, dirty hands are one of the most common sources of infection.

1. Wet your hands thoroughly with warm water.
2. Use soap.
3. Scrub hands for 20 seconds using a rotary motion and friction. Wash:
  - Back and palm of each hand
  - Between all fingers
  - Fingernails

Need a timer? Hum the "Happy Birthday" song from beginning to end twice.

4. Rinse your hands under the running water.
5. Dry on clean towel or with a paper towel.



*Wash hands for 20 seconds*

For additional good health habits, visit our patient education section on [apria.com](http://apria.com).

## Safety Precautions

### Use Your Equipment Safely

**Never immerse the CPAP or Bi-Level unit in water.**

Never try to clean the unit by placing it in water. The electrical components will be damaged and this can create a shock to the user the next time it is plugged into an electrical outlet.

**Never plug in the unit if it is wet or damp.**

Moisture always increases the potential of electrical shock.

**Never plug your unit into an electrical outlet that is being used to supply power to another major appliance.**

Plug your unit into an electrical outlet that is NOT being used to supply electricity to other major appliances. If you need to use the same outlet that is shared by other equipment, make sure the other appliances are NOT being used at the same time.

**Never try to repair your CPAP or Bi-Level unit.**

Your unit is considered medical equipment and needs to be worked on by a professional. If you are renting this equipment, call Apria Healthcare and your unit will be replaced. If you have purchased the

unit, contact Apria Healthcare for assistance in getting it repaired.



*Never plug in unit if it is wet or damp*

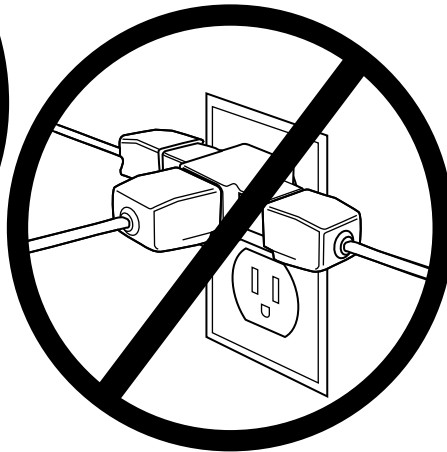

*Never plug into an outlet used by another major appliance*

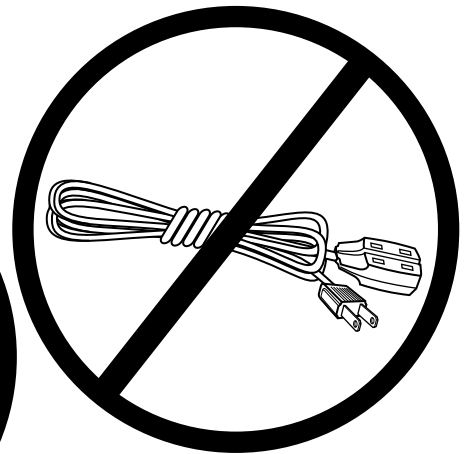

*Never use unit with an extension cord*

**Never use your unit with an extension cord.**

## **Make Sure Your Home Address Is Visible**

**Make sure your home address can be easily seen from the street during both day and night.**

If you are expecting a night delivery or visit, turn on the porch light. Check to see that your address numbers are easy to spot and read from the street. This will allow all Apria Healthcare and emergency services to locate your residence easily.

## **Follow Emergency and Natural Disaster Instructions**

In the event of an emergency or natural disaster, follow the radio or television instructions of your local authorities.

## **Travel Guidelines**

The following tips should help you plan and prepare for any trip.

- Contact your physician to make sure your proposed trip is medically safe and to obtain additional copies of your prescription.
- If traveling by plane, DO NOT check your CPAP or Bi-Level unit. Carry the unit on the plane with you in a padded case. Be sure to pack the cord, all accessories and the manufacturer's user manual.
- When traveling to another country, contact the equipment manufacturer to make sure you have the proper fuses and know the correct voltage setting. (See page 6.)

## **Warranty**

If you have purchased your CPAP/Bi-Level unit, please check the inserts from your packaging to determine the length of the warranty. Call Apria Healthcare if your equipment needs service.

## Common Problems and Their Solutions

Problem	Probable Cause	Solution
Sore or dry eyes.	Mask not positioned properly. Headgear adjusted improperly.	Reapply the mask and readjust headgear.
	Mask size not appropriate.	Contact Apria Healthcare to obtain the proper mask size.
Redness on the face where the mask contacts the skin.	Irritation or allergy to mask material.	Some users may experience skin redness, irritation, or discomfort. If this happens, discontinue use and contact your healthcare professional.
Runny nose.	Nasal reaction to air flow.	Contact your physician or Apria Healthcare. You may need to increase the room humidity or you may need a humidifier to use with your unit.
Cold nose.	Room air temperature is too cold. Air cools while traveling through the tubing.	Reposition the tubing so that it runs under your bed covers to reduce heat loss.
Dryness or burning sensation in throat or nose.	Air is too dry. The relative humidity is less than 40%.	<ul style="list-style-type: none"> <li>• Increase the room humidity (or moisture in the air).</li> <li>• Consult with your physician or Apria Healthcare about using a humidifier with your CPAP unit.</li> <li>• Ask your physician about nasal sprays or gels.</li> <li>• Make sure that you are keeping your mouth closed and take slow relaxed breaths through your nose. Use a chin strap.</li> </ul>

<b>Problem</b>	<b>Probable Cause</b>	<b>Solution</b>
Nasal, sinus or ear pain.	Sinus infection or middle ear infection.	Stop using the unit and contact your physician.
Feeling of discomfort from the sensation of too much pressure.	Pressures above 12.5 cm H <sub>2</sub> O may cause feelings of discomfort but are necessary to relieve sleep apneas.	It may take you up to four weeks to adjust to the system. Try to relax when using the unit. Take slow deep breaths through your nose with your mouth closed. If you still have trouble, contact your physician or Apria Healthcare.
Pressure delivered seems significantly lower or higher than usual.	Possible unit malfunction.	Contact Apria Healthcare.
Air from the unit seems warm.	The filter may be obstructed by debris.	Replace or clean the filter.
	The filter or slotted vents on the front and back of the unit may be blocked by bedclothes, curtains, etc.	Move the unit away from bedclothes or curtains that block the flow of air around the unit.
	The room temperature is too warm.	<ul style="list-style-type: none"> <li>• Turn down the thermostat at night.</li> <li>• Add a second length of tubing to the circuit to allow the air to cool.</li> <li>• Place the unit on the floor where the air may be cooler.</li> </ul>

## Troubleshooting

Trouble	Probable Cause	Remedy
Unit does not turn on.	Power cord not firmly connected to the unit or the outlet.	Verify proper electrical connections.
	Unit not connected to a "live" outlet.	Check to be sure that the unit is plugged into a live outlet (e.g., plug a working lamp into the outlet).
	Unit fuse has blown out.	Replace the fuses with the same fuse type. Verify that the voltage selector switch setting is not set too low (i.e., your electrical line is 230V but your switch is set on 115V). If the new fuses blow out, contact Apria Healthcare.
	DC battery voltage fell below 10.5 volts.	Recharge or replace battery.
Unit stops and starts.	Power cord not completely connected to the unit or the outlet.	Verify that the power cord is completely connected at the rear of the unit and at the outlet.
No air comes out of unit when power is connected.	Voltage selector switch is set incorrectly.	Verify that the voltage selection switch setting is not set too high (i.e., your electrical line is 115V but your switch is set on 230V).
	Possible internal problem.	Contact Apria Healthcare.
All other problems or equipment questions.		Contact Apria Healthcare.

---

## Feedback on Our Services

Apria Healthcare is among America's most experienced and respected home respiratory care providers, and our patient satisfaction scores are consistently high. It is possible, however, that you may have a concern and we welcome feedback. To voice a concern, you should take these steps:

1. Call the Apria Customer Service for Patient Concerns at **1 (800) 260-8808**  
OR
2. Contact us by e-mail at:  
**Patient\_Satisfaction@apria.com**  
OR
3. Visit our web site at **apria.com**

## Satisfaction Survey Process

Our goal is to ensure your satisfaction. You will likely receive an Apria patient satisfaction questionnaire and we hope that you will take a few minutes to fill it out and return it to us. The postage is prepaid by Apria Healthcare.





Visit us at  
[apria.com](http://apria.com)



*Education  
News  
Articles  
Services*