

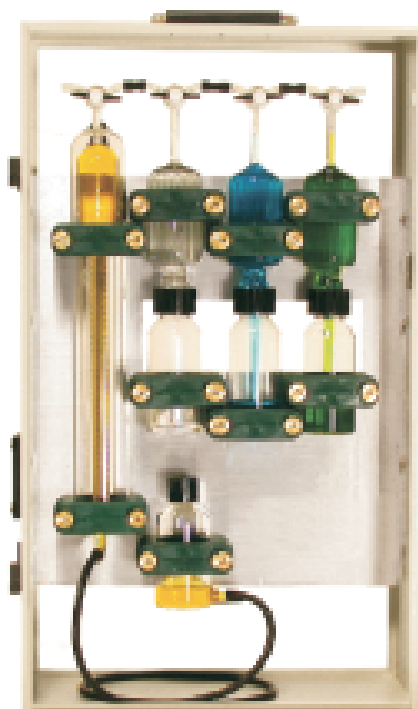

APEX INSTRUMENTS, INC.
Method 3 Gas Analysis
ORSAT Analyzer Manual



VSC-33
Operator's Manual



204 Technology Park Lane
Fuquay-Varina, NC 27526
www.apexinst.com
(919) 557-7300 (800) 882-3214

For Support or Service Contact:

Technical Services Group
support@apexinst.com
(877) 726-3919

VSC-33 Operator's Manual
Revision Date: 12.27.2018

Terms and Conditions**Prices and Terms**

All prices are subject to change without notice. The price in effect upon receipt of order will apply (prices are protected by quotation expiration date). All prices are Ex Works Fuquay-Varina, North Carolina or point of origin. Terms of payment are Net 30 days with established credit, or by credit card (Visa / MasterCard / American Express) at time of order. International orders may require payment by irrevocable letter of credit or payment in advance by wire transfer. Credit terms are discretionary and Apex Instruments reserves the right to change the credit terms at any time. Invoices over 30 days past due are subject to 1.5% per month finance charge.

Shipments and Delivery

Unless otherwise instructed, shipments are scheduled in accordance with our quoted delivery lead-time and/or as soon as possible after receipt of order. Unless otherwise instructed, shipments will be a method of transportation, which in our judgment is most satisfactory and cost effective. Unless directed to ship freight collect on the customer's freight account number, freight charges are prepaid and added to the invoice. Apex Instruments, Inc. reserves the right to make partial shipments where delays beyond our control may delay order shipment.

Recipient is responsible for examination of order upon delivery to ensure that there are no visible signs of damaged, missing and/or incorrect pieces. In the event that there are missing, damaged or incorrect packages, please retain the item(s), indicate the problem on the delivery receipt and contact us within 48 hours of your delivery. A signed delivery receipt, without notations of missing, damaged or incorrect item(s) represents your acceptance of the complete order in perfect condition. For any other problem with your order, please refer to our return policy

Export Processing and Pricing

Prices do not include customs and duty charges, freight, insurance; export fees, bank wire transaction fees or additional handling fees.

Prepayment Sales

Apex Instruments Inc. will work to ship prepay orders as quickly as possible after receipt of payment. Due to scheduling and production demands shipment from Apex Instruments may be delayed up to but no longer than 10 business days after receipt of payment.

Returned Items

A Return Merchandise Authorization (RMA) must be obtained from Apex Instruments before returning any goods. RMA's will only be issued for unused equipment returned in the same condition as shipped. When requesting return authorization, please advise reason for return, date of purchase, your P.O. number and our invoice number.

All returned material will be subject to an operation evaluation/inspection and the customer will be notified prior to final disposition. All returns must be shipped freight prepaid at the purchasers' expense. Returned merchandise may be subject to a restocking fee of up to 25%.

Equipment manufactured to customer's custom specifications and special-order nonstock items are not returnable.

Contact Apex Instruments to receive the RMA. Properly label and package the component and return to:

Apex Instruments, Inc.
RMA # _____
204 Technology Park Lane
Fuquay-Varina, NC 27526

Service Request

For warranty repairs, calibrations or technical support please contact our service department at 919-557-7300. The service department will issue you a service request number for you to attach to your product when shipping back to Apex Instruments. All items must be shipped freight prepaid at the purchasers' expense.

Warranty Policy**Product Limited Warranty Policy**

Apex Instruments, Inc. warrants products to be free from defects in materials and workmanship for a period of one year from date of delivery. During the warranty period, we will repair or replace, at our option, any component that fails due to a defect in materials or workmanship under normal use excluding installation. Items not manufactured by Apex Instruments are subject to original manufactures warranty. All returns must be shipped freight prepaid at the purchasers' expense.

Repair Services Limited Warranty Policy

Apex Instruments, Inc. warrants repairs to be free from defects in materials for a period of one year and workmanship for a period of 90 days from date of delivery. During the warranty period, we will repair any item Apex Instruments repaired or replaced that fails due to a defect in materials or workmanship under normal use.

What is Not Covered

Accidents, misuse, abuse and modifications. All forms of corrosion or other environmental conditions including lightning, natural disasters, improper installation and installation of an incorrect part. Normal wear and tear, used or salvage parts installed and shipping damage.

Contamination

Customer is responsible for decontamination of all equipment returned to Apex Instruments. Apex Instruments reserves the right to return or decontaminate any equipment deemed unsafe or contaminated at the customers expense.

Additional Important Information

This limited warranty does not cover labor cost or incidental, indirect, special or consequential damages such as, but not limited to, psychical injuries or property damage, loss of time, loss of use of the component, inconvenience, rental equipment charges, or accommodations resulting from a defect in or failure of the component. You must be the original purchaser of the component, warranty is not transferrable.

This limited warranty represents the exclusive remedy for any component defect or failure and the total liability of Apex Instruments for any component it warrants.

Apex Instruments makes no other warranties, express or implied, including any warranties of merchantability, condition of any kind or fitness for a particular purpose.

Some states do not allow disclaimers of implied warranties. Therefore, all implied warranties that may apply to the component are limited to the duration of this written warranty. Some states also do not allow limitations on how long an implied warranty lasts or the exclusion or limitation of incidental, special or consequential damages, so the above information may not apply. This warranty provides specific rights, and there may be other rights which vary from state to state. Apex Instruments, Inc does not authorize any entity to vary the terms, conditions or exclusions of this warranty. If any provision of the warranty should become invalid or unenforceable because of any laws, the remaining terms and provisions of the warranty shall remain in full force and effect. To the extent allowed under local law, the remedies provided in this Limited Warranty Policy are the purchaser's sole and exclusive remedies. Apex Instruments, Inc., 204 Technology Park Lane, Fuquay-Varina, NC 27526. Visit us on the web at www.apexinst.com

Acceptance of Terms and Conditions

Apex Instruments manufactures and sells its products under the foregoing terms and conditions and will not be bound to terms and conditions stated by any purchaser in any offer, acceptance or other contractual document. Placing an order or accepting delivery of products constitutes acceptance of terms and conditions.

SK-M3 Orsat Sampling Kit



<u>Part #</u>	<u>Description</u>
TS4-028	Probe, 1/4" x .028" Wall
PP-60LSAN15	Single-Headed Peristaltic Pump
TBC-5	Tedlar Bag Container
TB-12X21-P	12 Liter Tedlar Bag
TPOE-4/2YL	1/4" OD x 1/8" ID Yellow POE Tubing
4SC4-S	Fitting for TS4-028 Probe
QC-M4-SS	Fitting for Tubing to TB-5 Container
QC-GHF4V-SS	Female Valved Fitting for TBC-5 Container

NOTE: EPA Method 3 ¶ 6.1.1 Probe. Stainless steel or borosilicate glass tubing equipped with an in-stack or out-of-stack filter to remove particulate matter (a plug of glass wool is satisfactory for this purpose).



Squeeze Bulb Pump

The heavy wall rubber Squeeze Bulb Pump with stainless steel valves and connections can be used for gas sampling, pressure source for calibrations and leak tests, and for conditioning probes and sample lines.

A-350

TABLE OF CONTENTS

I. INTRODUCTION.....	4
II. UNPACKING AND REAGENT PREPARATION.....	6
III. ASSEMBLY & LEAK CHECK PROCEDURES.....	8
IV. OPERATION.....	13
V. RESULTS AND CALCULATIONS.....	15

TABLES

TABLE 1 LIST OF PARTS, VSC-33.....	6
TABLE 2 VSC-33 VALVE POSITIONS.....	12
TABLE 3 F_0 FACTORS FOR FOSSIL FUELS.....	18

FIGURES

FIGURE 1 VSC-33 ORSAT ANALYZER WITH TEDLAR BAG CONTAINER.....	4
FIGURE 2 VSC-33 PARTS DIAGRAM.....	5
FIGURE 3 VSC-33 GLASSWARE SET-UP.....	8
FIGURE 4 MARKING PIPETTE CAPILLARIES.....	10
FIGURE 5 TOP VIEW OF ORSAT WITH TEDLAR BAG ATTACHED TO PIPETTE BOTTLES.....	10
FIGURE 6 VSC-33 VALVE POSITION SCHEMATIC.....	12
FIGURE 7 MEASURING SAMPLE VOLUME USING LEVELING BOTTLE.....	15

I. Introduction

The analysis of gas samples to determine their oxygen (O_2) and carbon dioxide (CO_2) composition is an important procedure during the course of a source test. This information is required in order to calculate the flue gas molecular weight so that effluent velocities and volumetric flow rates can be calculated. At this time the pollutant concentrations can be corrected to a reference diluent concentration, such as seven percent oxygen or twelve percent carbon dioxide. Absorptometric gas analysis has long been a chief technique for the determination of O_2 and CO_2 concentrations for these purposes.

The Apex Instruments VSC-33 Orsat Analyzer (see Figure 1) consists of a graduated glass burette and three absorption pipettes. The burette and the pipettes are each fitted with three-way gas stopcocks, which enable the operator to load the analyzer with a gas sample, and then to direct the sample to the appropriate pipettes for analysis.

The sample is exposed to absorbing reagents in the pipettes to remove carbon dioxide, oxygen, (carbon monoxide). Each absorption pipette consists of a reagent bottle, a gas absorption bottle, with a three-way stopcock. During analysis, the volume of gas is measured before and after each absorption, under constant pressure and temperature. Any decrease in the sample gas volume is measured using the burette, and represents the amount of constituent that was present, with results reported on a volume percentage basis.

The pipettes are arranged so that a gas sample can be drawn into the analyzer, exhausted to the atmosphere, or directed to any of the absorption pipettes for gas analysis. A multi-compartment gas expansion bag is attached to the pipette reagent bottles to prevent exhaustion of the absorbents through air contact, and also to protect a long-standing sample from being slowly diffused with air. The bottom of the burette is connected to a leveling bottle which contains a confining liquid, consisting of an acidic sulfate solution. The confining solution is acidic in order to minimize diffusion of the gas sample into the solution during analytical procedures. By adjusting the height of the leveling bottle, gases in the burette can be brought to any desired volume, relative to the pressure of the confining liquid.

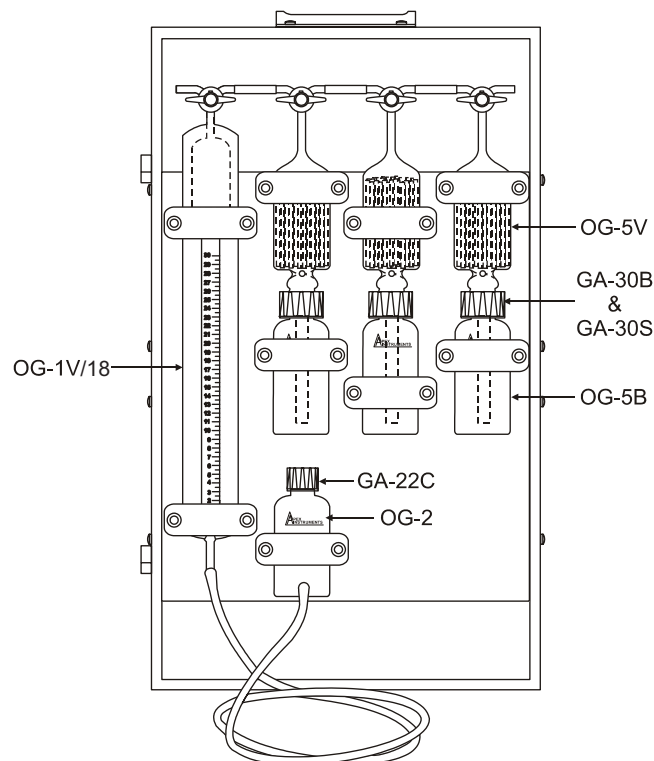

Figure 1 VSC-33 Orsat Analyzer

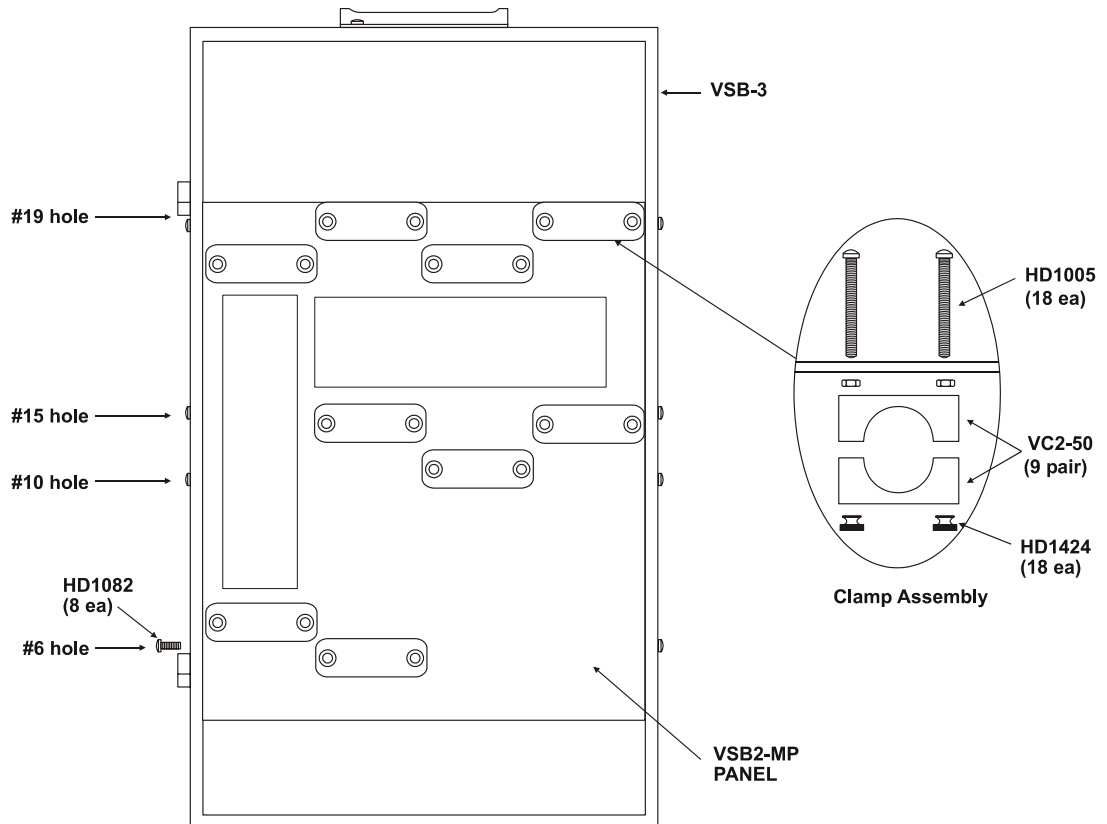
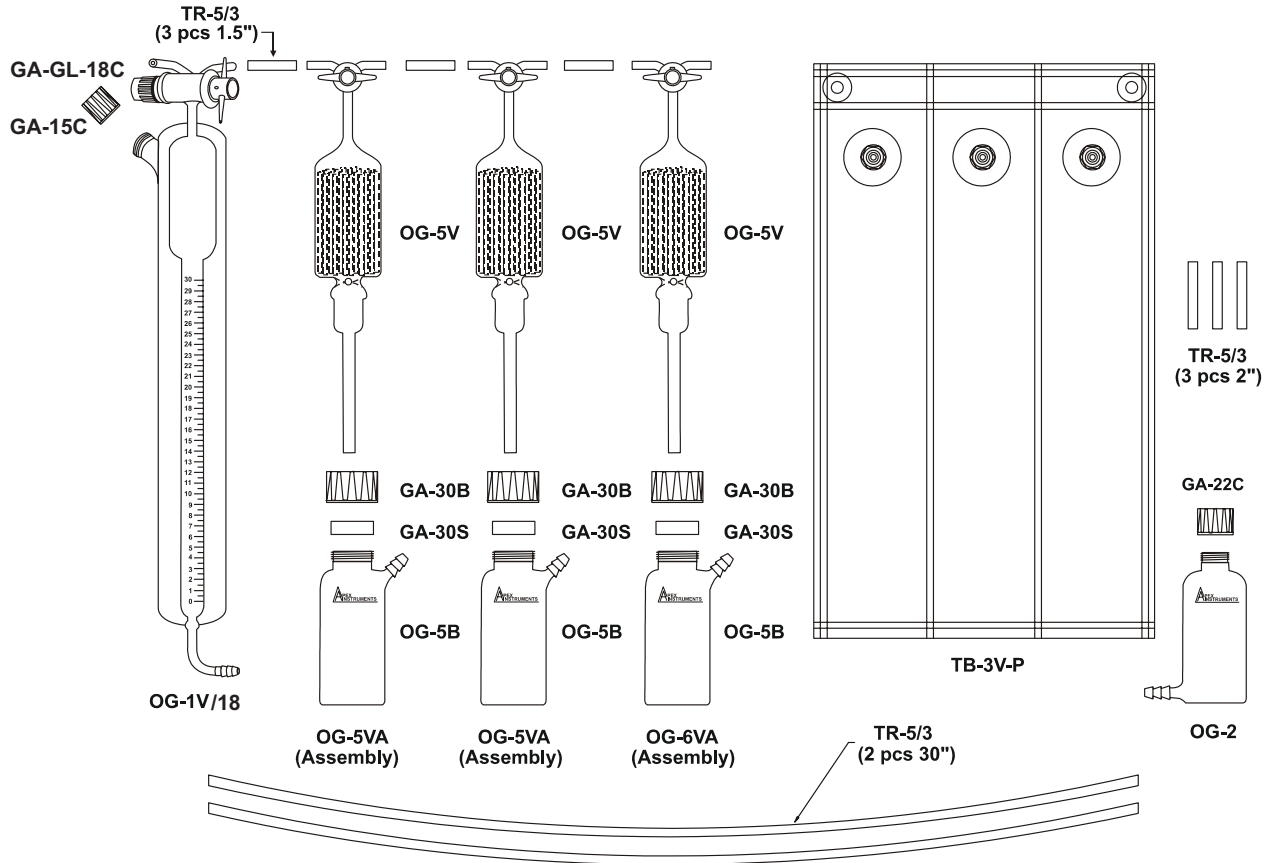

Figure 2 VSC-33 Parts Diagram

II. Unpacking And Reagent Preparation

The gas analysis apparatus is shipped disassembled in the VersaCase. Unpack the contents carefully, saving all the packaging material until the parts have been examined for shipping damage and the Orsat has been completely assembled. Check each item against the packing list below. If any item is damaged or missing, notify your supplier or Apex Instruments immediately.

Table 1 List of Parts, VSC-33

Quantity	Part Number	Description
1	VSB-3	VersaCase III
1	VSB2-MP	Orsat Mounting Panel
18	HD1005	1/4-20 3-in. Pan Head Phillips Screws
18	HD1422	1/4-20 Large Brass Knurled Nuts
8	HD1082	8-32 1/4-in Pan Head Phillips Screws
9	VC2-50	2-inch VC Burette Clamp
1	TB-3V-P	Gas Expansion Bag-3 Compartment
1	OG-1V	100-ml gas measuring burette with 3-way valve and water jacket
1	OG-2	Aspirator bottle with hose barb and #22 thread
3	OG-5V	Contact Pipette
3	OG-5B	Pipette Bottle
1	GA-15C	#15 Screw cap, solid
1	GA-22C	#22 Screw cap, solid
3	GA-30B	#30 Bored cap
3	GA-30S	30-mm Silicone Seal Ring
9 ft	TR-5/3	Rubber Tubing

Reagents

Absorbing reagents for the VSC-33 are not shipped with the glassware assemblies. These chemicals are either shipped directly from the vendor, or reagents may be mixed according to the recipes presented below. It is recommended persons preparing the reagents possess basic laboratory skills.

1. Confining Solution, (for use in burette). Add 100 g of sodium sulfate (NaSO_4) to 500 ml distilled water. To this solution, add 20 ml concentrated sulfuric acid, (H_2SO_4), and a few drops of methyl orange indicator.
2. Potassium hydroxide solution, 45%, (for CO_2 absorption). This solution can be purchased from chemical suppliers in 500 ml containers. Alternatively, the solution can be made by adding 440 g potassium hydroxide crystals to 1 liter distilled water.
3. Potassium pyrogallate solution, (for O_2 absorption). Add 22 g of pyrogallol (pyrogallic acid; 1,2,3-trihydroxybenzene) to 500 ml of 45% (w/w) KOH solution prepared in Step 2.
4. Cuprous chloride solution, acidic, (for CO absorption). *Carefully* add 650 ml of concentrated hydrochloric acid (HCl) to 325 ml distilled water. Slowly, and with frequent mixing, add a mixture of 86 g copper (II) oxide (CuO) and 17 g of metallic copper to the HCl solution. After addition of the CuO/Cu mixture, suspend a spiral copper wire to the bottom of the container. Shake occasionally. When the solution becomes colorless, it is ready for use.

Replacement Fluids

For Domestic Delivery Only

Drop Ship Direct Only due to Hazardous Classification

Burrell Oxsorbent

Solution for determining oxygen in gas analysis, 8 oz bottles.

Cases Only. 12 per Case.

B39-710

Burrell Cosorbent

Solution for determining Carbon Monoxide in gas analysis, 8 oz bottles.

Cases Only. 12 per Case.

B39-720

Burrell Disorbent

Solution for determining Carbon Dioxide in gas analysis, 16 oz, bottles.

Cases Only. 12 per Case.

B39-730

III. Assembly & Leak Check Procedures

Follow the procedures listed below to assemble the Orsat. *It is strongly recommended that the reader review these instructions thoroughly prior to assembling the apparatus.* A schematic diagram of a completely assembled VSC-33 analyzer is presented in Figure 3. Specific pipette filling instructions, given below, are designed to facilitate the absorption of carbon dioxide, oxygen, and carbon monoxide in sequence.. The chemicals for gas absorption may be prepared by the analyst using the instructions in the preceding section.

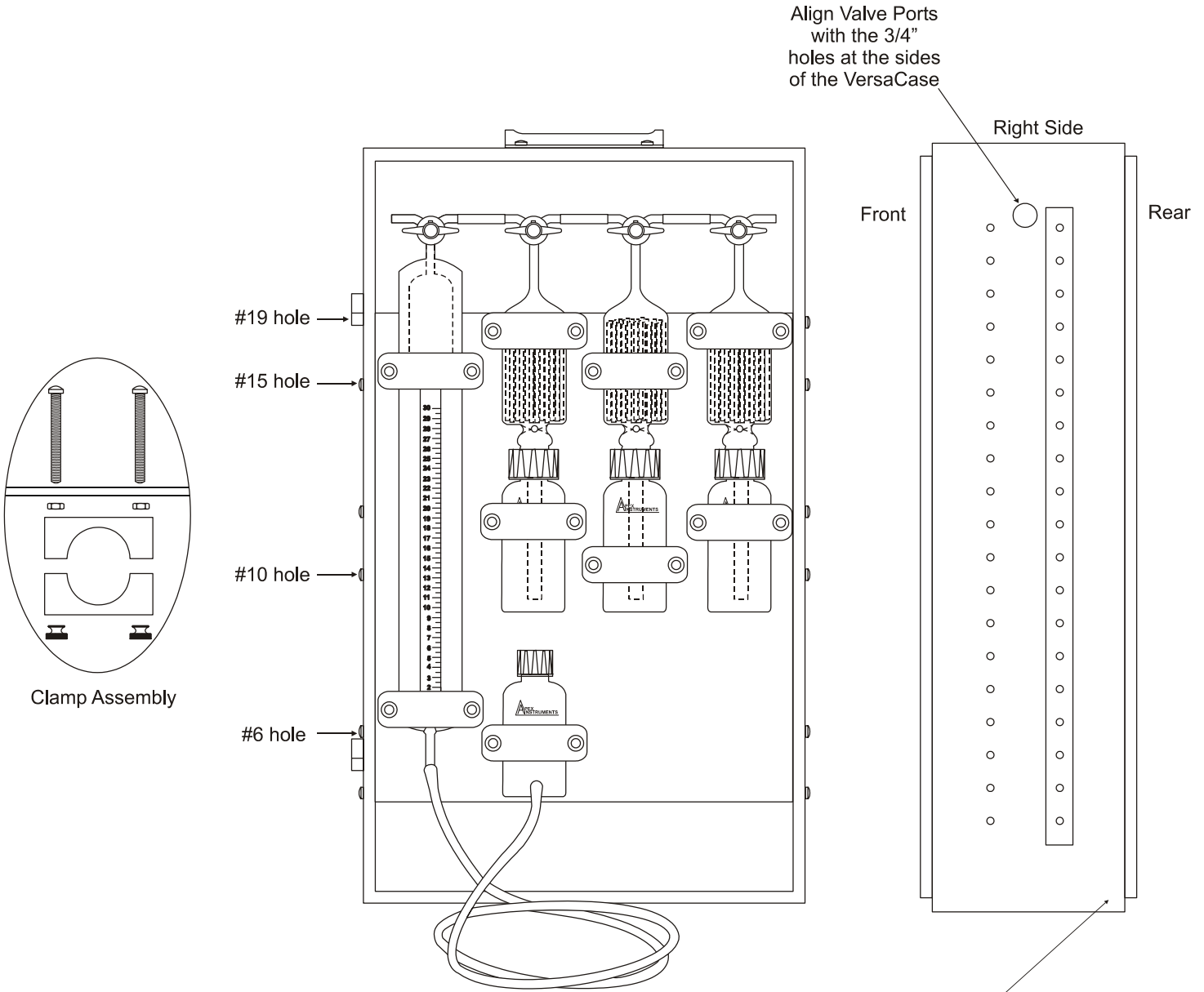

Figure 3 VSC-33 Glassware Set-up

Install the Panel so that the mounting surface is to the rear of the VersaCase

Assembly

1. Remove the door panels from the front and rear of the VersaCase frame. Place the VersaCase on a flat surface so that the hinges are to the left of the VersaCase.
2. If the stainless steel panel is not installed, install it using the 8/32 by 1/4-in screws. On the VersaCase support frame, locate the line of screw holes that run from top to bottom on each side of the case. Counting up from the bottom of the VersaCase frame, secure the panel using hole positions six (6), ten(10), fifteen(15) and nineteen (19). When installing the panel, make sure that the mounting surface of the panel faces toward the rear of the case. (see Figure 3)
3. Mount the nine VC2-50 clamps to the predrilled panel, using two 3" screws and the large brass knurled thumbnuts for each clamp. Fill the burette water jacket with distilled water to the top, and cap using the #15 screw cap. (The addition of a few drops of chlorine bleach will help to hinder mold growth.) Install the burette being certain that the numbered markings face the operator. Secure the burette in the clamp using two of the large knurled brass thumb nuts. (Figure 3)
4. The carbon dioxide (CO₂) absorption pipette assembly is installed to the immediate right of the burette using another VC-50F clamp. Mount the clamp to the top slot of the crossbar. Assemble one of the contact pipettes by placing one #30 bored cap and one #30 seal ring over the contact pipette stem, and inserting the stem of the contact pipette into the pipette bottle. Tighten the cap to form a leak-free seal. Mount a second clamp to the middle crossbar on the top slot, directly beneath the second clamp on the top crossbar. When installing the CO₂ pipette, make sure that it is positioned so that the 3-way stopcock valve on the contact faces towards the operator. (Figure 3)
5. The oxygen (O₂) absorption pipette will be installed to the immediate right of the CO₂ pipette assembly. Mount two VC-50F clamps, one on the bottom slot of the top crossbar and one to the bottom slot of the middle crossbar. Place one #30 bored cap and one #30 seal ring on the contact pipe stem. Insert the stem into the pipette bottle and tighten the cap to form a leak free seal. Secure the O₂ assembly in the clamp using four of the large knurled brass thumb nuts, making sure the stopcock valve is facing the operator. (Figure 3)
6. If carbon monoxide (CO) analyses are required, use the remaining contact pipette assembly for this purpose. Place a #30 bored cap and #30 seal ring over the contact stem and insert the stem into a pipette bottle. Tighten the cap to form a leak free seal. Mount two VC-50F clamps to the extreme right of the case, both on the top slots of the top and middle crossbars. Secure the pipette assembly in the clamps using four of the large knurled brass thumb nuts, making sure the stopcock valve is facing the operator. (Figure 3)
7. Secure the aspirator bottle to the clamp at the bottom of the panel. Attach a 30" piece of rubber tubing to the hose barb of the aspirator bottle and hose barb of the burette. (Figure 3)
8. Connect the burette and the absorption pipettes together using the 1 1/2 inch pieces of the supplied rubber tubing. Check to ensure that the absorption pipettes are securely attached to the support clamps and that the stopcock bodies are free of debris to form leak-free seals.

1. Using a grease pencil or similar marking device, place a reference mark on the capillary tubing of each absorption pipette. The reference mark should be located about half way between the pipette bodies and the stopcock. The exact position of these marks is not critical. The marks are only a reference point to ensure that the manifold volume is the same during each reading of the burette volume. (Figure 4)

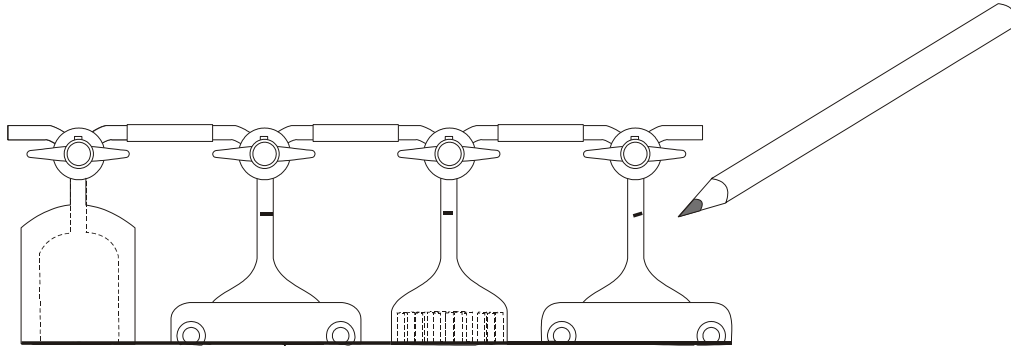
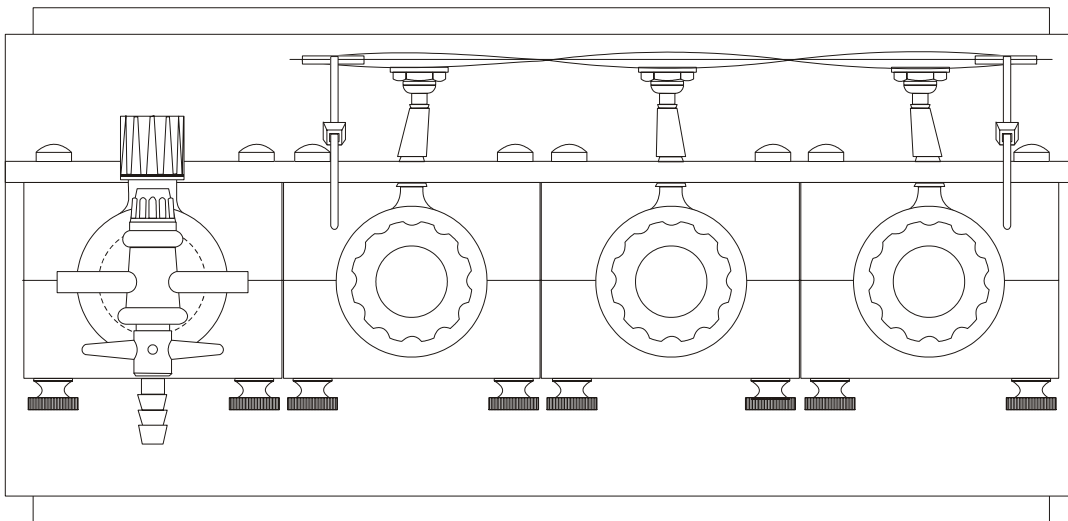

Figure 4 Marking Pipette Capillaries

2. Attach the Tedlar expansion bag to the top crossbar using plastic wire ties or a wire. Suspend the bag from the crossbar using the brass eyelets so that the metal hose bars hang close to the glass hose bars on the reagent bottles. Using 2 inch pieces of rubber tubing, attach the hose bars on the reagent bottles to the three-section Tedlar bag hose bars. (Figure 5)



* Shown without Contacts to illustrate Bag to Bottle Connections.

Figure 5 Top View of Orsat with Tedlar Bag attached to Pipette Bottles

Adding Reagents

1. With the leveling bottle resting on a firm flat surface, fill the aspirator bottle with the acidic sulfate solution. Add two or three drops of methyl orange indicator to enhance visibility of the solution in the pipette. This solution is known as the confining solution. Cap the bottle with one #22 cap and secure the aspirator bottle in its storage position on the bottom crossbar.
2. Remove the absorption bottle from the carbon dioxide pipette assembly by loosening the #30 bored cap and VC-50F clamp on the middle crossbar. Fill the bottle with KOH absorbing solution and reattach the bottle to the absorption pipette. In the same fashion, remove the absorption bottle from the oxygen pipette assembly, and fill the bottle with alkaline paragallol. If carbon monoxide analyses are required, remove the carbon monoxide absorption bottle from the carbon monoxide pipette, and fill with acidic cuprous chloride reagent, and reattach to the carbon monoxide absorption pipette. Ensure that all components are secure in their clamps.

Adjusting reagent levels and conducting a leak check

1. Open the burette valve to ambient air. (Figure 6, Position C) Raise the aspirator bottle to allow the confining solution to flow from the aspirator bottle to the burette. Carefully observe the confining solution as it fills the burette. Close the burette valve when the confining solution just starts to enter the capillary tubing. (Figure 6, Position D)
2. Hold the aspirator bottle at the level of the top of the burette. Open the burette valve to the CO₂ absorption pipette assembly.(Figure 6, Position A) Open the CO₂ valve to the burette. (Figure 6, Position C). Lower the aspirator bottle to allow the confining solution to flow out of the burette pulling the CO₂ KOH into the pipette. Watch the level of the KOH solution carefully as it rises in the CO₂ pipette assembly. When the KOH solution reaches the reference mark on the capillary tubing, close the CO₂ valve. Attach one section of the Gas Expansion Bag to the hose barb on the CO₂ pipette bottle using a 2 inch piece of the supplied rubber tubing.
3. Repeat Step 2 for the O₂ pipette and, if required, the CO pipette. During the reagent level adjustment procedure, the stopcock valve on the oxygen and carbon dioxide absorption pipettes should be turned to Position C when each of the bottles is being adjusted.
4. After the fluid levels of the absorption pipettes are properly adjusted, open the burette valve and draw approximately 100 ml of air into the burette by lowering the leveling bottle. When the level of the burette solution is close to, but not below, the zero mark, close the burette valve. (Figure 6, Position D) Place the leveling bottle on top of the VersaCase. Observe the levels of the burette and absorbing solutions for a period of four (4) minutes. The apparatus is considered to have passed the leak check if the meniscus in the burette rises by no more than 0.2 ml and the levels of the absorbing solutions do not fall below the capillary tubing.
5. After the leak check, return the confining solution to its proper level by opening the burette valve to ambient, and raise the aspirator bottle until the level of the confining solution reaches the capillary tubing. Close the burette valve.

Figure 6 VSC-33 Valve Position Schematic

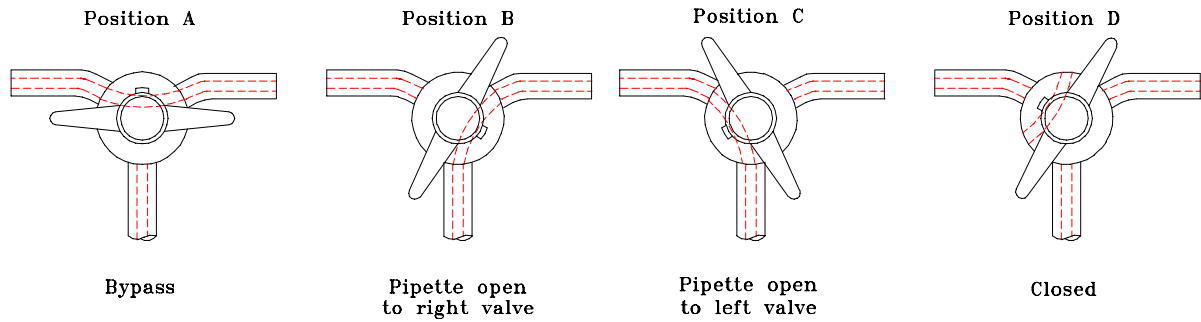

Table 2 VSC-33 Valve Positions
(refer to Figure 6)

Analytical Step	Burette Valve Position	CO ₂ Pipette Valve Position	O ₂ Pipette Valve Position	CO Pipette Valve Position
Initial leak check	A	A	A	A
Connect bag to analyzer	C	A	A	A
Purge analyzer with sample	B	A	A	A
Load sample into analyzer	C	A	A	D
Stabilize Sample	C	A	A	D
CO ₂ absorption passes	B	C	A	D
O ₂ absorption passes	B	A	C	D
CO absorption passes	B	A	A	C
Flushing of Manifold	A	A	A	A

IV. OPERATION

The general information below includes comments on sampling techniques, compensation for temperature and pressure, number of passes required, and accuracy and speed.

I. Sampling Techniques

- A. The operator should keep in mind that the smallest division of the burette is 0.1 ml. Therefore, the resolution of the analyzer is 1 percent for a ten ml sample, but only 0.1 percent for a 100 ml sample. For this reason, although smaller samples may be analyzed, it is strongly recommended that a 100-ml sample volume be used for all analyses.
- B. It is important to ensure that not only the proper gas be collected, but that the gas not be contaminated, diluted with ambient air, depleted of certain components by dissolution in confining liquids, or reacted with metal tubes or containers.
- C. The sample may be delivered directly to the analyzer through a sampling tube, or it may be collected and stored in a Tedlar bag and delivered later to the analyzer. The operator should note that gases remaining in the manifold after an analysis are considered to be nitrogen. The sampling tube and the connections must be well purged with the gas prior to making an analysis.
- D. The operator should also be cautioned that the volume marks on the burette do not include the volume within the manifold. The error introduced by this volume will be negligible if a sufficiently large sample is used. For this reason also, small samples should be avoided if maximum accuracy is desired.

II. Compensation

- A. Since the Orsat apparatus requires the measurement of gas volumes at constant temperature and pressure, provisions must be made to ensure that changes of temperature and pressure do not interfere during the course of an analysis. Since the apparatus is portable, with no automatic pressure compensation, reference pressure is always that of the atmosphere. This is compensated for, before measurements are taken, by specific procedures to produce identical liquid levels in both burette and leveling bottle. Procedures are also included to adjust any gas in the manifold to the same pressure as in the leveling bottle.

III. Number of Passes

- A. It is difficult to state the number of passes required for the absorption of any particular component since this varies with such factors as the design of the pipette, the reagent used, the age of the reagent, etc.
- B. Normally three or four passes will be sufficient for carbon dioxide. Six or more passes may be required for absorption of oxygen and carbon monoxide. If more than five passes for complete absorption of carbon dioxide, or more than twelve for oxygen, are required, the reagent should be discarded and replaced with fresh solution.
- C. *NOTE: The only way to make certain that a particular component has been removed completely is to pass the gas once more into the pipette, and note if any contraction in volume takes place.*

Accuracy and Speed

- A. In analyzing gases, the operator should strive for accuracy and speed. To ensure accuracy the operator must determine whether or not the components being tested for are present in the gas

sample. Unnecessary absorptions should not be made as small decreases in volume will be observed due to solubility of specific components other than the specific reaction the absorbent is intended for. Care must also be taken that each absorption is complete.

- B. Avoiding unnecessary passes will also expedite the absorption procedure.
- C. *NOTE: When performing analyses, it is important that the operator always observe the level of rising fluid, such as the confining solution, to ensure that the fluid does not "overshoot" the capillary and contaminate the other pipettes.*

Analysis of gas samples using the Orsat consists of three general processes. These are 1) preparing the analyzer to analysis by purging with the sample to be analyzed, 2) loading the analyzer with a 100-ml gas sample and zeroing the burette, and 3) passing the gas sample through the absorption pipettes recording the reduction in sample volume. To analyze samples using the VSC-33 Orsat apparatus, proceed as follows:

I. Analytical Technique

1. Prepare the Orsat Analyzer for Analysis.
 - a. Set the valves on each of the absorption pipettes to the bypass position. Indicating marks on all pipette stopcocks should be pointing upward. (Figure 6, Position A.)
 - b. Connect the container containing the gas sample to the inlet leg of the burette stopcock using a short piece of the supplied rubber tubing. Open the burette stopcock to the gas sample. The indicating mark on the stopcock valve should be pointed towards the gas sample container. (Figure 6, Position C.)
 - c. Lower the leveling bottle, to allow the confining solution to flow from the burette into the leveling bottle. When the level of the confining solution falls below the zero mark, crimp the rubber hose connecting the leveling bottle with the burette to quickly stop the flow of the confining solution.
 - d. Turn the valve on the burette so that the gas flow is open the bypassed carbon monoxide pipette. (Figure 6, Position B). Raise the leveling bottle so that the confining solution rises in the burette and expels the gas sample through the stopcock valves of the absorption pipettes, to ambient air. When the level of the confining solution reaches the glass capillary tubing, crimp the rubber tubing.
 - e. Repeat steps b, c, and d two additional times to ensure that the burette is completely flushed with the gas sample.
2. Load the analyzer and zero the burette.
 - a. Connect the gas sample container to the burette and open the burette stopcock to the sample container. (Figure 6, Position C). Lower the leveling bottle so that the confining solution flows out of the burette and into the leveling bottle. When the confining solution reaches the zero mark, crimp the rubber tubing, and use the leveling bottle to adjust the level of fluid in the burette so that the bottom of the meniscus is at the zero mark on the burette.
 - b. Close the stopcock on the burette. Allow the sample to thermally equilibrate for a period of about three minutes.
3. Pass the gas sample through the absorption pipettes for gas analysis.
 - a. Open the stopcock on the burette to the carbon dioxide absorption pipette, and open the stopcock on the carbon dioxide absorption pipette. (Figure 6, Position B for burette valve position, and Valve Position C for the CO₂ pipette valve position).
 - b. Raise the leveling bottle so that the confining solution fills the burette. When the confining solution reaches the top of the capillary, crimp the rubber tubing. Lower the leveling bottle, being

careful to observe the level of the disorbent solution in the carbon dioxide pipette. When the level of the disorbent solution in the carbon dioxide pipette reaches the capillary, crimp the tubing on the leveling bottle. Observe the level of the meniscus in the burette.

- c. Continuously repeat Step B until the amount of carbon dioxide absorbed from the sample (e.g., the level of the meniscus) does not change. Typically, three passes of the sample through the absorption pipette is sufficient for the complete absorption of CO_2 . Close the stopcock on the burette and on the CO_2 pipette and record the position of the meniscus. To ensure the correct reading of the meniscus, hold the aspirator bottle as shown in Figure 7.
- d. Open the stopcock on the burette to the oxygen absorption pipette, and open the stopcock on the oxygen absorption pipette.
- e. Raise the leveling bottle so that the confining solution fills the burette. When the confining solution reaches the top of the capillary, crimp the rubber tubing. Lower the leveling bottle, being careful to observe the level of the oxysorbent solution in the oxygen pipette. When the level of the oxysorbent solution in the oxygen pipette reaches the capillary, crimp the tubing on the leveling bottle. Observe the level of the meniscus in the burette.
- f. Repeat the previous step until the amount of oxygen absorbed from the sample (the level of the meniscus) does not change. Typically six passes of the sample through the absorption pipette is sufficient for the complete absorption of O_2 . Close the stopcock on the burette and on the O_2 pipette and record the position of the meniscus.
- g. If carbon monoxide analysis is desired open the stopcock on the burette to the carbon monoxide absorption pipette, and open the stopcock on the carbon monoxide absorption pipette.
- h. Raise the leveling bottle so that the confining solution fills the burette. When the confining solution reaches the top of the capillary, crimp the rubber tubing. Lower the leveling bottle, being careful to observe the level of the cosorbent solution in the carbon monoxide pipette. When the level of the cosorbent solution in the carbon monoxide pipette reaches the capillary, crimp the tubing on the leveling bottle. Observe the level of the meniscus in the burette.
- i. Repeat the previous step until the amount of carbon monoxide absorbed from the sample (the level of the meniscus) does not change. Typically, three passes of the sample through the absorption pipette is sufficient for the complete absorption of CO . Close the stopcock on the burette and on the CO pipette and record the position of the meniscus.

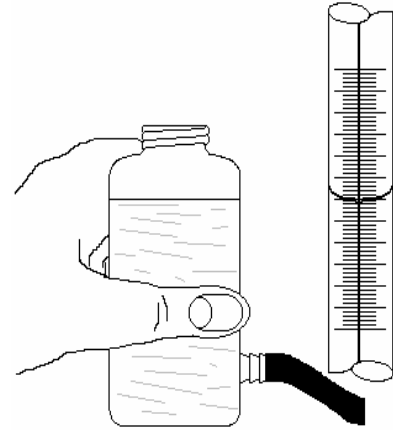

Figure 7 Measuring Sample Volume using Leveling Bottle

V. Results And Calculations

Calculation of Results

The results of carbon dioxide and oxygen analyses are used to calculate the dry molecular weight, M_d , of an effluent gas. M_d is used in conjunction with data from velocity and temperature traverses and moisture measurements to calculate the velocity and volumetric flow rate of an effluent gas. Stack gas molecular weight is calculated according to the following equation:

$$M_d = 0.440(\% \text{CO}_2) + 0.320(\% \text{O}_2) + 0.280(\% \text{N}_2 + \% \text{CO})$$

where:

M_d = Dry molecular weight, g/g·mole (lb/lb·mole)

$\%CO_2$ = Percent CO_2 by volume, dry basis

$\%O_2$ = Percent O_2 by volume, dry basis

$\%CO$ = Percent CO by volume, dry basis

$\%N_2$ = Percent N_2 by volume, dry basis

0.280 = Molecular weight of CO or N_2 , divided by 100

0.320 = Molecular weight of O_2 , divided by 100

0.440 = Molecular weight of CO_2 , divided by 100

The concentrations of carbon dioxide, oxygen, and, if performed, carbon monoxide are measured directly as the decrease in volume of the effluent gas sample after each analysis. The concentrations of each of the constituents are calculated as follows:

$$\%CO_2 = (V_{CO_2} - V_i)$$

$$\%O_2 = (V_{O_2} - V_{CO_2})$$

$$\%CO = (V_{CO} - V_{O_2})$$

$$\%N = (100 - \%CO_2 - \%O_2 - \%CO)$$

where:

V_i = Initial burette volume, ml (assumed to be 0)

V_{CO_2} = Volume of gas sample as read on burette, after passes through CO_2 absorption pipette, ml

V_{O_2} = Volume of gas sample as read on burette, after passes through O_2 absorption pipette, ml

V_{CO} = Volume of gas sample as read on burette, after passes through CO absorption pipette, ml

Data Validation

For any given fuel burned in air, a relationship between the oxygen (O_2) and carbon dioxide (CO_2) concentrations exists. This relationship can be used to validate the results of the Orsat analysis immediately after the analysis is completed based upon the type of fuel combusted. Since air is used for the combustion process, the law of conservation of mass demands:

$$\%O_2 + F_o CO_2 = 20.9$$

where:

% O_2 = oxygen content by volume (expressed as percent), dry basis

% CO_2 = carbon dioxide content by volume (expressed as percent), dry basis

F_O = fuel factor; depends on type of fuel burned

20.9 = oxygen content in air by volume (expressed as percent), dry basis

Solving for F_O , we obtain:

$$F_O = \frac{20.9 - \%O_2}{\%CO_2}$$

The factor F_O is mainly a function of the hydrogen to carbon ratio in the fuel. At zero percent excess air, (i.e., when fuel is burned completely at stoichiometric conditions and the flue gas oxygen concentration is zero) this equation simplifies to:

$$F_O = \frac{20.9}{(\%CO_2)_{ult}}$$

where $(CO_2)_{ult}$ is the ultimate, or maximum, CO_2 concentration that the effluent gas is able to attain for the given fuel. If the ultimate analysis of the fuel is known, the value of $(CO_2)_{ult}$ can be calculated using the following equation:

$$(\%CO_2)_{ult} = \frac{0.321\%C(100)}{1.53\%C + 3.64\%H + 0.57\%S + 0.14\%N - 0.46\%O}$$

where %C, %H, %S, %N, and %O are the percent by weight of carbon, hydrogen, sulfur, nitrogen, and oxygen, respectively, as obtained from an ultimate analysis of the fuel.

The equations presented above can be used to check Orsat data or other analyses of oxygen and carbon dioxide concentrations after they have been adjusted to a dry basis. This process simply involves the comparison of the F_O values obtained from the Orsat analysis with F_O values calculated from an ultimate analysis of the fuels being burned, or by comparison with published F_O values.

Table 3 F₀ Factors for Fossil Fuels

Fuel Type	F ₀ Range	(%CO ₂) _{ult}
Coal, anthracite	1.016 - 1.130	19.53
Coal, bituminous	1.083 - 1.230	18.34
Coal, Lignite	1.016 - 1.130	19.42
Oil, residual	1.210 - 1.370	15.74
Oil, distillate	1.260 - 1.413	15.52
Gas, natural	1.600 - 1.836	11.95
Gas, propane	1.434 - 1.586	13.85
Gas, butane	1.405 - 1.553	14.13