



# IRONWOLF

NAS

SATA Product Manual



## Standard model

ST6000VN001

ST4000VN008

ST4000VN006

ST3000VN007

ST3000VN006

ST2000VN004

ST1000VN002

100807039, Rev. M  
June 2021

## Document Revision History

Revision	Date	Pages affected and Description of Change
Rev. A	10/12/2016	Initial release.
Rev. B	10/17/2016	9: Table 1 Op Shock value 23: Renamed Figure 3 to reflect 6, 7 & 8TB models 24-25: Replaced mechanical drawings for Figure 4 - 4TB & Figure 5 - 2TB-3TB models
Rev. C	12/09/2016	6, 8 & 10: Remove references to RPM
Rev. D	06/21/2017	10: Revised Max height to 20.20 mm 26: Revised Mechanical Drawing (Fig 6) Z-heights to 20.20 mm
Rev. E	07/24/2017	fc, 6, 8-9, 11-12, 14, 18-19, 24 & 33: Change 6TB model to ST6000VN0033 8: Updated 6TB Recording & Track densities, cache size & Internal data transfer rate 21: Added Taiwan BSMI statement 24: Added 6TB mechanical drawing
Rev. F	09/28/2017	20-23: Updated Safety, EMC, FCC & RoHS Sections 2.12 through 2.13.3, per Compliance Council
Rev. G	11/03/2017	17: Added Figure 2: Location of the HDA temperature check point 24: Updated Table 10: Taiwan - Restricted Substances - Unit row headers = HDD & PCBA 26-30: Updated fastener penetration depth in Section 3.4 & Fig. 4-8 = 0.140 in.
Rev. H	04/13/2018	21: Added Regulatory Model Number 26-27 & 29-30: Added missing side hole metric dimension (28.50 mm)
Rev. J	03/13/2019	21: Updated Regulatory model numbers 24: Updated Table 10: Taiwan - Restricted Substances bc: Updated APAC & EMEA addresses
Rev. K	05/22/2019	6: Removed TGMR bull bc: Removed APAC & EMEA addresses
Rev. L	03/11/2021	fc: Added Rescue logo fc, 6, 8-9, 11-12, 14, 18-19, 21, 26 & 35: Removed 8TB model & changes 6TB ST# 5: Update Seagate Technology Support Services page 8 & 10: Updated Sustained Data Rate, weights & Cache buffer sizes 8-11: Revised operating temperature range statements & notes 9 & 11: Removed MTBF & added AFR to specification Tables 1 & 2 9 & 11: Added (command controlled) to L/UL entries 17: Updated Section 2.6 Environmental limits 20: Updated Section 2.9 Reliability 21: Updated Section 2.10 HDD and SSD Regulatory Compliance and Safety 21: Added Section 2.12 Reference documents 22: Added Section 2.13 Product warranty 23: Added Section 2.14 Seagate Rescue Data Recovery Service bc: Updated Americas HQ address
Rev. M	06-14-2021	fc, 8-9, 11-12, 14, 19, 21, 27-28 & 35: Added new 3TB & 4TB models 8 & 10: Removed Wet bulb temperature row 9, 11 & 19: Updated Vibration, operating range from (2Hz to 22Hz) to (10Hz to 22Hz) 15: Updated square-wave to sine-wave 17: Deleted HDA Temperature Check Point image & note 20: Updated Table 9 Radio frequency environments 25: Updated Figure 3 Attaching SATA cabling

© 2021, Seagate Technology LLC All rights reserved.

Publication number: 100807039, Rev. M June 2021

Seagate, Seagate Technology and the Spiral logo are registered trademarks of Seagate Technology LLC in the United States and/or other countries. SeaTools is either trademarks or registered trademarks of Seagate Technology LLC or one of its affiliated companies in the United States and/or other countries. All other trademarks or registered trademarks are the property of their respective owners.

No part of this publication may be reproduced in any form without written permission of Seagate Technology LLC.  
Call 877-PUB-TEK1 (877-782-8351) to request permission.

When referring to drive capacity, one gigabyte, or GB, equals one billion bytes and one terabyte, or TB, equals one trillion bytes. Your computer's operating system may use a different standard of measurement and report a lower capacity. In addition, some of the listed capacity is used for formatting and other functions, and thus will not be available for data storage. Actual quantities will vary based on various factors, including file size, file format, features and application software. Actual data rates may vary depending on operating environment and other factors. The export or re-export of hardware or software containing encryption may be regulated by the U.S. Department of Commerce, Bureau of Industry and Security (for more information, visit [www.bis.doc.gov](http://www.bis.doc.gov)), and controlled for import and use outside of the U.S. Seagate reserves the right to change, without notice, product offerings or specifications.

<b>Seagate® Technology Support Services</b> .....	<b>5</b>
<hr/>	
<b>1.0 Introduction</b> .....	<b>6</b>
1.1 About the SATA interface .....	7
<hr/>	
<b>2.0 Drive Specifications</b> .....	<b>8</b>
2.1 Specification summary tables .....	8
2.2 Formatted capacity .....	11
2.2.1 LBA mode .....	12
2.3 Default logical geometry .....	12
2.4 Seek time .....	12
2.5 Start/stop times .....	12
2.6 Power specifications .....	13
2.6.1 Power consumption .....	13
2.6.2 Typical current profile .....	15
2.6.3 Conducted noise .....	15
2.6.4 Voltage tolerance .....	15
2.6.5 Power-management modes .....	16
2.7 Environmental limits .....	17
2.7.1 Temperature .....	17
2.7.2 Humidity .....	18
2.7.3 Altitude .....	18
2.7.4 Shock .....	18
2.7.5 Vibration .....	19
2.8 Acoustics .....	19
2.8.1 Test for Prominent Discrete Tones (PDTs) .....	19
2.9 Electromagnetic immunity .....	20
2.10 Reliability .....	20
2.10.1 Annualized Failure Rate (AFR) and Mean Time Between Failures (MTBF) .....	20
2.11 HDD and SSD Regulatory Compliance and Safety .....	21
2.11.1 Regulatory models .....	21
2.12 Corrosive environment .....	21
2.13 Reference documents .....	21
2.14 Product warranty .....	22
2.15 Seagate® Rescue™ Data Recovery Service .....	23

---

<b>3.0</b>	<b>Configuring and Mounting the Drive</b> .....	<b>25</b>
3.1	Handling and static-discharge precautions .....	25
3.2	Configuring the drive .....	25
3.3	SATA cables and connectors .....	25
3.4	Drive mounting .....	26

---

<b>4.0</b>	<b>SATA Interface</b> .....	<b>30</b>
4.1	Hot-Plug compatibility .....	30
4.2	SATA device plug connector pin definitions .....	30
4.3	Supported ATA commands .....	31
4.3.1	Identify Device command .....	33
4.3.2	Set Features command .....	37
4.3.3	S.M.A.R.T. commands .....	38

# Figures

Figure 1	Typical Current Profile (5V & 12V).....	15
Figure 2	Attaching SATA cabling.....	25
Figure 3	Mounting dimensions (6TB).....	26
Figure 4	Mounting dimensions (ST4000VN008, ST4000VN006 & ST3000VN006 models).....	27
Figure 5	Mounting dimensions (ST3000VN007 & ST2000VN004 models) .....	28
Figure 6	Mounting dimensions (1TB).....	29

# Seagate® Technology Support Services

For Seagate Product Support, visit: [www.seagate.com/support](http://www.seagate.com/support)

For Seagate Compliance, Safety, and Disposal, visit: [www.seagate.com/support](http://www.seagate.com/support)

For Firmware Download and Tools Download for Secure Erase, visit: [www.seagate.com/support/downloads/](http://www.seagate.com/support/downloads/)

For information regarding online support and services, visit: [www.seagate.com/contacts/](http://www.seagate.com/contacts/)

For information regarding Warranty Support, visit: [www.seagate.com/support/warranty-and-replacements/](http://www.seagate.com/support/warranty-and-replacements/)

For information regarding data recovery services, visit: [www.seagate.com/services-software/recover/resources/](http://www.seagate.com/services-software/recover/resources/)

For Seagate OEM and Distribution partner and Seagate reseller portal, visit: [www.seagate.com/partners](http://www.seagate.com/partners)

## 1.0 Introduction

---

This manual describes the functional, mechanical and interface specifications for the following: Seagate® IronWolf™ model drives:

ST6000VN001	ST4000VN008	ST2000VN004
ST4000VN006	ST3000VN007	ST1000VN002
ST3000VN006		

These drives provide the following key features:

- 24x7 capability
- Balance technology to support multiple drives in a system
- Compliant with RoHS requirements in China and Europe
- Full-track multiple-sector transfer capability without local processor intervention
- Low activity and idle power
- Native Command Queuing with command ordering to increase performance in demanding applications
- Off-the-shelf compatibility
- Performance-tuned for RAID applications
- Rated for 1M hours MTBF
- SeaTools diagnostic software performs a drive self-test that eliminates unnecessary drive returns.
- State-of-the-art cache and on-the-fly error-correction algorithms
- Streaming video optimization - consistent command completion times & ERC support
- Support for S.M.A.R.T. drive monitoring and reporting
- Supports ATA8 streaming commands
- Supports latching SATA cables and connectors
- Worldwide Name (WWN) capability uniquely identifies the drive

## 1.1 About the SATA interface

The Serial ATA (SATA) interface provides several advantages over the traditional (parallel) ATA interface. The primary advantages include:

- Easy installation and configuration with true plug-and-play connectivity. It is not necessary to set any jumpers or other configuration options.
- Thinner and more flexible cabling for improved enclosure airflow and ease of installation.
- Scalability to higher performance levels.

In addition, SATA makes the transition from parallel ATA easy by providing legacy software support. SATA was designed to allow users to install a SATA host adapter and SATA disk drive in the current system and expect all of the existing applications to work as normal.

The SATA interface connects each disk drive in a point-to-point configuration with the SATA host adapter. There is no master/slave relationship with SATA devices like there is with parallel ATA. If two drives are attached on one SATA host adapter, the host operating system views the two devices as if they were both “masters” on two separate ports. This essentially means both drives behave as if they are Device 0 (master) devices.

The SATA host adapter and drive share the function of emulating parallel ATA device behavior to provide backward compatibility with existing host systems and software. The Command and Control Block registers, PIO and DMA data transfers, resets, and interrupts are all emulated.

The SATA host adapter contains a set of registers that shadow the contents of the traditional device registers, referred to as the Shadow Register Block. All SATA devices behave like Device 0 devices. For additional information about how SATA emulates parallel ATA, refer to the “Serial ATA International Organization: Serial ATA Revision 3.2”. The specification can be downloaded from [www.sata-io.org](http://www.sata-io.org).

**Note**

The host adapter may, optionally, emulate a master/slave environment to host software where two devices on separate SATA ports are represented to host software as a Device 0 (master) and Device 1 (slave) accessed at the same set of host bus addresses. A host adapter that emulates a master/slave environment manages two sets of shadow registers. This is not a typical SATA environment.



## 2.0 Drive Specifications

Unless otherwise noted, all specifications are measured under ambient conditions, at 25°C, and nominal power. For convenience, the phrases *the drive* and *this drive* are used throughout this manual to indicate the following drive models:

ST6000VN001      ST4000VN008      ST2000VN004  
 ST4000VN006      ST3000VN007      ST1000VN002  
 ST3000VN006

### 2.1 Specification summary tables

The specifications listed in [Table 1](#) are for quick reference. For details on specification measurement or definition, refer to the appropriate section of this manual.

**Table 1** Drive specifications summary for 6TB models

Drive Specification*	ST6000VN001	ST4000VN006	ST3000VN006
Formatted capacity (512 bytes/sector)**	6000GB (6TB)	4000GB (4TB)	3000GB (3TB)
Guaranteed sectors	11,721,045,168	7,814,037,168	5,860,533,168
Heads	10	4	
Disks	5	2	
Bytes per sector (4K physical emulated at 512-byte sectors)	4096		
Default sectors per track	63		
Default read/write heads	16		
Default cylinders	16,383		
Recording density (max) (KBPI)	1984	2448	
Track density (avg) (KTPI)	370	480	
Areal density (avg) (Gb/in <sup>2</sup> )	732	1175	855
Internal data transfer rate (max) (Mb/s)	1981	2230	
Maximum sustained data rate, OD read (MiB/s)	181 (190 MB/s)	193 (202 MB/s)	
ATA data-transfer modes supported	PIO modes: 0 to 4 Multiword DMA modes: 0 to 2 Ultra DMA modes 0 to 6		
I/O data-transfer rate (max)	600MB/s		
Cache buffer	256MB		
Height (max)	26.11mm / 1.028 in	20.20mm / 0.795 in (max)	
Width (max)	101.85mm / 4.010 in		
Length (max)	146.99mm / 5.787 in		
Weight (max)	610g / 1.345 lb	490g / 1.08 lb	
Average latency	4.0ms	6.0 ms	
Startup current (typical) 12V	1.8A		
Voltage tolerance (including noise)	5V: ±5% 12V: ±10%		
Non-Operating (Ambient °C)	-40 to 70		
Operating ambient temperature (min °C) #	0°		
Operating temperature (drive reported max °C)	65°†		
Temperature gradient	20°C per hour max (operating) 30°C per hour max (nonoperating)		
Relative humidity	5% to 90% (operating) 5% to 95% (nonoperating)		

**Table 1 Drive specifications summary for 6TB models (continued)**

Drive Specification*	ST6000VN001	ST4000VN006	ST3000VN006
Relative humidity gradient (max)	30% per hour		
Altitude, operating	-304m to 3048m (-1000 ft to 10,000 ft)		
Altitude, non-operating (below mean sea level, max)	-304m to 12,192m (-1000ft to 40,000+ ft)		
Operational Shock (max)	70 Gs at 2ms	80 Gs at 2ms	
Non-Operational Shock (max)	250 Gs at 2ms	300 Gs at 2ms	
Vibration, operating	10Hz to 22Hz: 0.25 Gs, Limited displacement 22Hz to 350Hz: 0.50 Gs 350Hz to 500Hz: 0.25 Gs		
Vibration, non-operating	5Hz to 22Hz: 3.0 Gs 22Hz to 350Hz: 3.0 Gs 350Hz to 500Hz: 3.0 Gs		
Drive acoustics, sound power			
Idle***	2.7 bels (typical) 2.8 bels (max)	2.3 bels (typical) 2.4 bels (max)	
Seek	2.8 bels (typical) 2.9 bels (max)	2.7 bels (typical) 2.8 bels (max)	
Non-recoverable read errors	1 per 10 <sup>15</sup> bits read	1 per 10 <sup>14</sup> bits read	
Annualized Failure Rate (AFR)*	0.87% based on 8760 POH		
Rated Workload	Maximum rate of <180TB/year Workloads exceeding the annualized rate may degrade the drive MTBF and impact product reliability. The Annualized Workload Rate is in units of TB per year, or TB per 8760 power on hours. Workload Rate = TB transferred * (8760 / recorded power on hours).		
Warranty	To determine the warranty for a specific drive, use a web browser to access the following web page: <a href="http://www.seagate.com/support/warranty-and-replacements/">www.seagate.com/support/warranty-and-replacements/</a> . From this page, click on the "Is my Drive under Warranty" link. The following are required to be provided: the drive serial number, model number (or part number) and country of purchase. The system will display the warranty information for the drive.		
Load/Unload cycles (command controlled)	600,000		
Supports Hotplug operation per the Serial ATA Revision 3.2 specification	Yes		

The following table footnotes apply to **Table 1** and **Table 2**:

\* All specifications above are based on native configurations.

\*\* One GB equals one billion bytes and 1TB equals one trillion bytes when referring to hard drive capacity. Accessible capacity may vary depending on operating environment and formatting.

\*\*\* During periods of drive idle, some offline activity may occur according to the S.M.A.R.T. specification, which may increase acoustic and power to operational levels.

† Seagate does not recommend operating at sustained drive temperatures above 60°C. Operating at higher temperatures may affect drive health.

# The operating temperature is 0 to 65°C (32 to 149°F).

<b>Note</b>	If the drive is powered-off before issuing flush cache command, in some instances, the end user data in the DRAM cache might not be committed to the disk.
-------------	--

**Table 2** Drive specifications summary for 4TB, 3TB and 2TB models

Drive Specification*	ST4000VN008	ST3000VN007	ST2000VN004	ST1000VN002
Formatted capacity (512 bytes/sector)**	4000GB (4TB)	3000GB (3TB)	2000GB (2TB)	1000GB (1TB)
Guaranteed sectors	7,814,037,168	5,860,533,168	3,907,029,168	1,953,525,168
Heads	6	6/5	4	2
Disks	3	3	2	1
Bytes per sector (4K physical emulated at 512-byte sectors)	4096			
Default sectors per track	63			
Default read/write heads	16			
Default cylinders	16,383			
Recording density (max)	2089kBPI	1740kBPI		1807kFCI
Track density (avg)	388ktracks/in	346ktracks/in		352ktracks/in
Areal density (avg)	810Gb/in <sup>2</sup>	613Gb/in <sup>2</sup>		625Gfc/in <sup>2</sup>
Internal data transfer rate (max)	2107Mb/s	1813Mb/s		2147Mb/s
Maximum sustained data rate, OD read (MiB/s)	172 (180MB/s)			
ATA data-transfer modes supported	PIO modes: 0 to 4 Multiword DMA modes: 0 to 2 Ultra DMA modes 0 to 6			
I/O data-transfer rate (max)	600MB/s			
Cache buffer	64MB			
Height (max)	26.11mm / 1.028 in			20.20mm / 0.795 in
Width (max)	101.85mm / 4.010 in			
Length (max)	146.99mm / 5.787 in			
Weight (max)	635g / 1.345 lb	535g / 1.18 lb		415g / 0.915 lb
Average latency	5.1ms			
Power-on to ready (max)	<17.0s			<6.0s
Standby to ready (max)	<17.0s			<6.0s
Average seek, read (typical)	<12.0ms			<8.5ms
Average seek, write (typical)	<12.0ms			<19.5ms
Startup current (typical) 12V	1.8A			1.2A
Voltage tolerance (including noise)	5V: ±5% 12V: ±10%			
Non-Operating (Ambient °C)	-40 to 70			
Operating ambient temperature (min °C)*	0°C (Ambient)			
Operating temperature (max °C)*	65°C (Drive Reported Temperature) †			
Temperature gradient	20°C per hour max (operating) 30°C per hour max (nonoperating)			
Relative humidity	5% to 90% (operating) 5% to 95% (nonoperating)			
Relative humidity gradient (max)	30% per hour			
Altitude, operating	-304m to 3048m (-1000 ft to 10,000 ft)			
Altitude, non-operating (below mean sea level, max)	-304m to 12,192m (-1000ft to 40,000+ ft)			
Operational Shock (max)	80 Gs at 2ms			
Non-Operational Shock (max)	300 Gs at 2ms			

**Table 2 Drive specifications summary for 4TB, 3TB and 2TB models (continued)**

Drive Specification*	ST4000VN008	ST3000VN007	ST2000VN004	ST1000VN002
Vibration, operating	10Hz to 22Hz: 0.25 Gs, Limited displacement 22Hz to 350Hz: 0.50 Gs 350Hz to 500Hz: 0.25 Gs			
Vibration, non-operating	5Hz to 22Hz: 3.0 Gs 22Hz to 350Hz: 3.0 Gs 350Hz to 500Hz: 3.0 Gs			
Drive acoustics, sound power				
Idle***	2.3 bels (typical) 2.4 bels (max)		1.9 bels (typical) 2.0 bels (max)	
Seek	2.5 bels (typical) 2.6 bels (max)		2.1 bels (typical) 2.2 bels (max)	
Non-recoverable read errors	1 per 10 <sup>14</sup> bits read			
Annualized Failure Rate (AFR)*	0.87% based on 8760 POH			
Rated Workload	Maximum rate of <180TB/year Workloads exceeding the annualized rate may degrade the drive MTBF and impact product reliability. The Annualized Workload Rate is in units of TB per year, or TB per 8760 power on hours. Workload Rate = TB transferred * (8760 / recorded power on hours).			
Warranty	To determine the warranty for a specific drive, use a web browser to access the following web page: <a href="http://www.seagate.com/support/warranty-and-replacements/">www.seagate.com/support/warranty-and-replacements/</a> . From this page, click on the "Is my Drive under Warranty" link. The following are required to be provided: the drive serial number, model number (or part number) and country of purchase. The system will display the warranty information for the drive.			
Load/Unload cycles (command controlled)	600,000		—	
Contact start-stop cycles (25°C, 50% rel. humidity)	—		50,000	
Supports Hotplug operation per the Serial ATA Revision 3.2 specification	Yes			

## 2.2 Formatted capacity

Model	Formatted capacity*	Guaranteed sectors	Bytes per sector
ST6000VN001	6000GB	11,721,045,168	4096
ST4000VN008, ST4000VN006	4000GB	7,814,037,168	
ST3000VN007, ST3000VN006	3000GB	5,860,533,168	
ST2000VN004	2000GB	3,907,029,168	
ST1000VN002	1000GB	1,953,525,168	

\*One GB equals one billion bytes and 1TB equals one trillion bytes when referring to hard drive capacity. Accessible capacity may vary depending on operating environment and formatting.

## 2.2.1 LBA mode

When addressing these drives in LBA mode, all blocks (sectors) are consecutively numbered from 0 to  $n-1$ , where  $n$  is the number of guaranteed sectors as defined above.

See [Section 4.3.1, "Identify Device command"](#) (words 60-61 and 100-103) for additional information about 48-bit addressing support of drives with capacities over 137GB.

## 2.3 Default logical geometry

- **Cylinders:** 16,383
- **Read/write heads:** 16
- **Sectors per track:** 63

### LBA mode

When addressing these drives in LBA mode, all blocks (sectors) are consecutively numbered from 0 to  $n-1$ , where  $n$  is the number of guaranteed sectors as defined above.

## 2.4 Seek time

Seek measurements are taken with nominal power at 25°C ambient temperature. All times are measured using drive diagnostics. The specifications in the table below are defined as follows:

- Track-to-track seek time is an average of all possible single-track seeks in both directions.
- Average seek time is a true statistical random average of at least 5000 measurements of seeks between random tracks, less overhead.

Typical seek times (ms)	Read	Write
Track-to-track	1.0	1.2
Average (1TB - 4TB models)	<12.0	<12.0
Average (6TB models)	8.5	9.5
Average latency (1TB - 4TB models)	<6.0	
Average latency (6TB models)	4.0	

<b>Note</b>	These drives are designed to consistently meet the seek times represented in this manual. Physical seeks, regardless of mode (such as track-to-track and average), are expected to meet the noted values. However, due to the manner in which these drives are formatted, benchmark tests that include command overhead or measure logical seeks may produce results that vary from these specifications.
-------------	---

## 2.5 Start/stop times

The start/stop times listed below are for all models.

	ST6000VN001 models	ST4000VN006, ST3000VN006 models	ST4000VN008, ST3000VN007, ST2000VN004, ST1000VN002 models
Power-on to ready (in seconds)	23 (typical) / 30 (max)	17 (typical) / 30 (max)	
Standby to ready (in seconds)			
Ready to spindle stop (in seconds)	23 (max)	12 (typical)	10 (typical) / 11 (max)

Time-to-ready may be longer than normal if the drive power is removed without going through normal OS powerdown procedures.

## 2.6 Power specifications

The drive receives DC power (+5V or +12V) through a native SATA power connector. Refer to [Figure 2 on page 25](#).

### 2.6.1 Power consumption

Power requirements for the drives are listed in [Table 6](#). Typical power measurements are based on an average of drives tested, under nominal conditions, using 5.0V and 12.0V input voltage at 25°C ambient temperature.

- Spinup power  
Spinup power is measured from the time of power-on to the time that the drive spindle reaches operating speed.
- Read/write power and current  
Read/write power is measured with the heads on track, based on a 16-sector write followed by a 32-ms delay, then a 16-sector read followed by a 32-ms delay.
- Operating power and current  
Operating power is measured using 40 percent random seeks, 40 percent read/write mode (1 write for each 10 reads) and 20 percent drive idle mode.
- Idle mode power  
Idle mode power is measured with the drive up to speed, with servo electronics active and with the heads in a random track location.
- Standby mode  
During Standby mode, the drive accepts commands, but the drive is not spinning, and the servo and read/write electronics are in power-down mode.

**Table 3 DC power requirements for 1TB models**

Power dissipation (1-disk values shown)	Avg (watts 25°C)	Avg 5V typ amps	Avg 12V typ amps
Spinup	—	—	1.2
Idle* †	2.502	0.152	0.145
Operating	3.676	0.385	0.145
Standby	0.58	0.096	0.0084
Sleep	0.58	0.096	0.0084

**Table 4 DC power requirements for 2TB models**

Power dissipation (2-disk values shown)	Avg (watts 25°C)	Avg 5V typ amps	Avg 12V typ amps
Spinup	—	—	1.8
Idle* †	3.56	0.171	0.225
Operating	4.30	0.308	0.233
Standby	0.50	0.09	0.005
Sleep	0.50	0.09	0.005

**Table 5** DC power requirements for 3TB and 4TB models

Power dissipation (4-disk values shown)	Avg (watts 25°C)	Avg 5V typ amps	Avg 12V typ amps
Spinup	—	—	1.8
Idle* †	3.96	0.12	0.28
Operating	4.85	0.29	0.283
Standby	0.51	0.09	0.005
Sleep	0.51	0.09	0.005

**Table 6** DC power requirements for 6TB models

Power dissipation	Avg (watts 25° C)	Avg 5V typ amps	Avg 12V typ amps
Spinup	—	—	1.8
Idle* †	7.60	0.191	0.553
Operating	8.80	0.23	0.54
Standby	0.60	0.09	0.01
Sleep	0.60	0.09	0.01

\* Idle1. During periods of drive idle, some offline activity may occur according to the S.M.A.R.T. specification, which may increase acoustic and power to operational levels.

† 5W IDLE with DIPLM Enabled

## 2.6.2 Typical current profile

Figure 1 Typical Current Profile (5V & 12V)

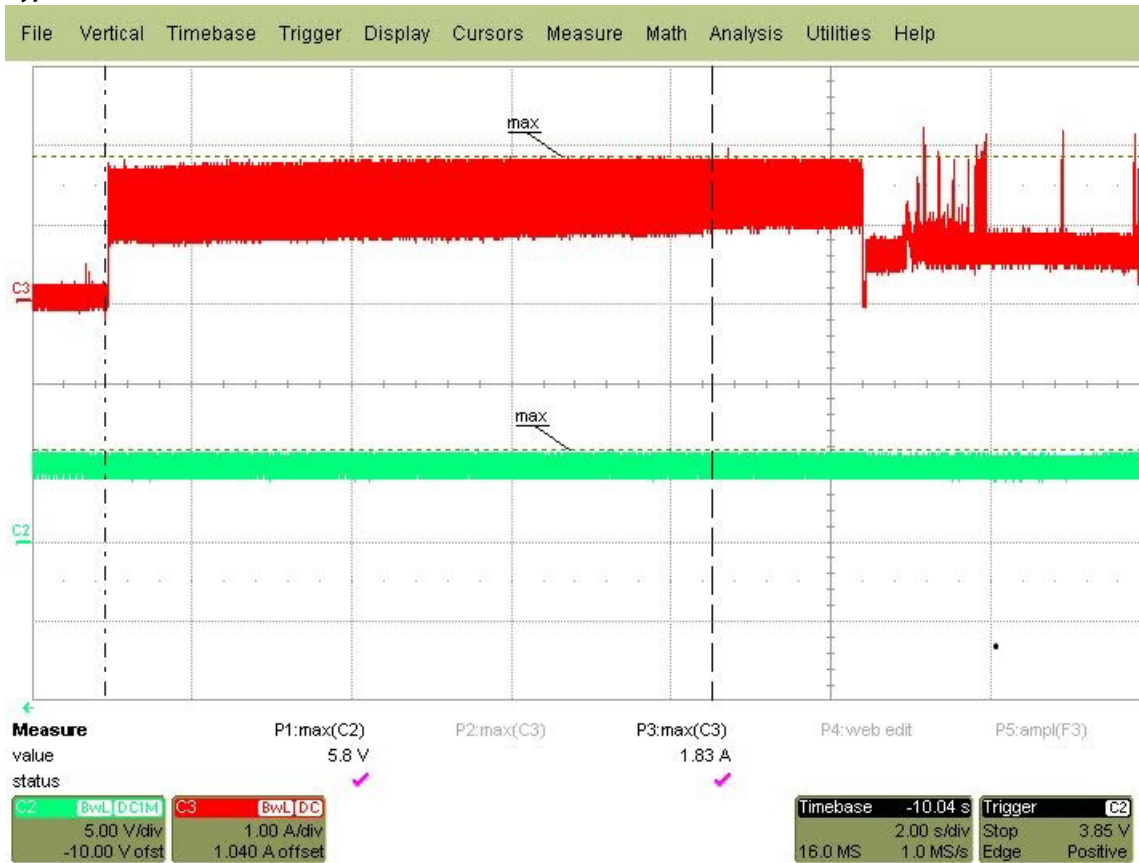

## 2.6.3 Conducted noise

Input noise ripple is measured at the host system power supply across an equivalent 80-ohm resistive load on the +12 volt line or an equivalent 15-ohm resistive load on the +5 volt line.

- Using 12-volt power, the drive is expected to operate with a maximum of 120 mV peak-to-peak sine-wave injected noise at up to 10MHz.
- Using 5-volt power, the drive is expected to operate with a maximum of 100 mV peak-to-peak sine-wave injected noise at up to 10MHz.

**Note** Equivalent resistance is calculated by dividing the nominal voltage by the typical RMS read/write current.

## 2.6.4 Voltage tolerance

Voltage tolerance (including noise):

- 5V ±5%
- 12V ±10%



## 2.6.5 Power-management modes

The drive provides programmable power management to provide greater energy efficiency. In most systems, users can control power management through the system setup program. The drive features the following power-management modes:

Power modes	Heads	Spindle	Buffer
Active	Tracking	Rotating	Enabled
Idle	Tracking	Rotating	Enabled
Standby	Parked	Stopped	Enabled
Sleep	Parked	Stopped	Disabled

- **Active mode**  
The drive is in Active mode during the read/write and seek operations.
- **Idle mode**  
The buffer remains enabled, and the drive accepts all commands and returns to Active mode any time disk access is necessary.
- **Standby mode**  
The drive enters Standby mode when the host sends a Standby Immediate command. If the host has set the standby timer, the drive can also enter Standby mode automatically after the drive has been inactive for a specifiable length of time. The standby timer delay is established using a Standby or Idle command. In Standby mode, the drive buffer is enabled, the heads are parked and the spindle is at rest. The drive accepts all commands and returns to Active mode any time disk access is necessary.
- **Sleep mode**  
The drive enters Sleep mode after receiving a Sleep command from the host. In Sleep mode, the drive buffer is disabled, the heads are parked and the spindle is at rest. The drive leaves Sleep mode after it receives a Hard Reset or Soft Reset from the host. After receiving a reset, the drive exits Sleep mode and enters Standby mode with all current translation parameters intact.
- **Idle and Standby timers**  
Each time the drive performs an Active function (read, write or seek), the standby timer is reinitialized and begins counting down from its specified delay times to zero. If the standby timer reaches zero before any drive activity is required, the drive makes a transition to Standby mode. In both Idle and Standby mode, the drive accepts all commands and returns to Active mode when disk access is necessary.

## 2.6 Environmental limits

Temperature and humidity values experienced by the drive must be such that condensation does not occur on any drive part. Altitude and atmospheric pressure specifications are referenced to a standard day at 58.7°F (14.8°C).

<b>Caution</b>	To maintain optimal performance drives should be run at nominal drive temperatures and humidity. Seagate does not recommend operating at sustained drive temperatures above 60°C. Operating at higher temperatures may affect drive health.  See <a href="#">Section 2.9, "Reliability"</a> for rated MTBF device operating condition requirements.
----------------	---

### 2.6.1 Temperature

#### a. Operating

32°F to 149°F (0°C ambient to 65°C drive reported) temperature range with a maximum temperature gradient of 36°F (20°C) per hour.

The maximum allowable drive reported temperature is 149°F (65°C).

Air flow may be required to achieve consistent nominal drive temperature values (see [Section 2.6](#)). To confirm that the required cooling is provided for the electronics and HDA, place the drive in its final mechanical configuration, and perform random write/read operations. After the temperatures stabilize, monitor the current drive temperature using the SMART temperature attribute 194 or Device Statistics log 04h page 5.

#### b. Non-operating

–40° to 158°F (–40° to 70°C) package ambient with a maximum gradient of 36°F (20°C) per hour. This specification assumes that the drive is packaged in the shipping container designed by Seagate for use with drive.

## 2.6.2 Humidity

### 2.6.2.1 Relative humidity

<b>Operating</b>	5% to 90% non-condensing (30% per hour max)
<b>Nonoperating</b>	5% to 95% non-condensing (30% per hour max)

### 2.6.2.2 Wet bulb temperature

<b>Operating</b>	26°C / 78.8°F (rated)
<b>Non-operating</b>	29°C / 84.2°F (rated)

## 2.6.3 Altitude

<b>Operating</b>	-304m to 3048m (-1000 ft. to 10,000 ft.)
<b>Non-operating</b>	-304m to 12,192m (-1000 ft. to 40,000+ ft.)

## 2.6.4 Shock

All shock specifications assume that the drive is mounted securely with the input shock applied at the drive mounting screws. Shock may be applied in the X, Y or Z axis.

### 2.6.4.1 Operating shock

#### 1TB - 4TB

These drives comply with the performance levels specified in this document when subjected to a maximum operating shock of 80 Gs based on half-sine shock pulses of 2ms during read operations. Shocks should not be repeated more than 2 times per second.

#### 6TB

These drives comply with the performance levels specified in this document when subjected to a maximum operating shock of 70 Gs based on half-sine shock pulses of 2ms during read operations. Shocks should not be repeated more than 2 times per second.

### 2.6.4.2 Non-operating shock

#### 1TB - 4TB

The non-operating shock level that the drive can experience without incurring physical damage or degradation in performance when subsequently put into operation is 300 Gs based on a non-repetitive half-sine shock pulse of 2ms duration.

#### 6TB

The non-operating shock level that the drive can experience without incurring physical damage or degradation in performance when subsequently put into operation is 250 Gs based on a non-repetitive half-sine shock pulse of 2ms duration.

## 2.6.5 Vibration

All vibration specifications assume that the drive is mounted securely with the input vibration applied at the drive mounting screws. Vibration may be applied in the X, Y or Z axis. Throughput may vary if improperly mounted.

### 2.6.5.1 Operating vibration

The maximum vibration levels that the drive may experience while meeting the performance standards specified in this document are specified below.

10Hz to 22Hz	0.25 Gs (Limited displacement)
22Hz to 350Hz	0.50 Gs
350Hz to 500Hz	0.25 Gs

### 2.6.5.2 Non-operating vibration

The maximum non-operating vibration levels that the drive may experience without incurring physical damage or degradation in performance when subsequently put into operation are specified below.

5Hz to 22Hz	3.0 Gs (Limited displacement)
22Hz to 350Hz	3.0 Gs
350Hz to 500Hz	3.0 Gs

## 2.7 Acoustics

Drive acoustics are measured as overall A-weighted acoustic sound power levels (no pure tones). All measurements are consistent with ISO document 7779. Sound power measurements are taken under essentially free-field conditions over a reflecting plane. For all tests, the drive is oriented with the cover facing upward.

<b>Note</b>	For seek mode tests, the drive is placed in seek mode only. The number of seeks per second is defined by the following equation:
	(Number of seeks per second = $0.4 / (\text{average latency} + \text{average access time})$ )

**Table 7 Fluid Dynamic Bearing (FDB) motor acoustics**

	Idle*	Seek
1TB & 2TB models	1.9 bels (typ) 2.0 bels (max)	2.1 bels (typ) 2.2 bels (max)
ST3000VN007 & ST4000VN008 models	2.3 bels (typical) 2.4 bels (max)	2.5 bels (typical) 2.6 bels (max)
ST3000VN006 & ST4000VN006 models	2.3 bels (typical) 2.4 bels (max)	2.7 bels (typical) 2.8 bels (max)
6TB models	2.7 bels (typical) 2.8 bels (max)	2.8 bels (typical) 2.9 bels (max)

\*During periods of drive idle, some offline activity may occur according to the S.M.A.R.T. specification, which may increase acoustic and power to operational levels.

### 2.7.1 Test for Prominent Discrete Tones (PDTs)

Seagate follows the ECMA-74 standards for measurement and identification of PDTs. An exception to this process is the use of the absolute threshold of hearing. Seagate uses this threshold curve (originated in ISO 389-7) to discern tone audibility and to compensate for the inaudible components of sound prior to computation of tone ratios according to Annex D of the ECMA-74 standards.

## 2.8 Electromagnetic immunity

When properly installed in a representative host system, the drive operates without errors or degradation in performance when subjected to the radio frequency (RF) environments defined in [Table 8](#).

**Table 8 Radio frequency environments**

Test	Description	Performance level	Reference standard
Electrostatic discharge	Contact, HCP, VCP: ± 4 kV; Air: ± 8 kV	B	EN61000-4-2: 95
Radiated RF immunity	80MHz to 1,000MHz, 3 V/m, 80% AM with 1kHz sine	A	EN61000-4-3: 96
Electrical fast transient	± 1 kV on AC mains, ± 0.5 kV on external I/O	B	EN61000-4-4: 95
Surge immunity	± 1 kV differential, ± 2 kV common, AC mains	B	EN61000-4-5: 95
Conducted RF immunity	150kHz to 80MHz, 3 Vrms, 80% AM with 1kHz sine	A	EN61000-4-6: 97
Voltage dips, interrupts	0% open, 5 seconds 0% short, 5 seconds 40%, 0.10 seconds 70%, 0.01 seconds	C C C B	EN61000-4-11: 94

## 2.9 Reliability

### 2.9.1 Annualized Failure Rate (AFR) and Mean Time Between Failures (MTBF)

The production disk drive shall achieve an annualized failure-rate of 0.87% (MTBF of 1,000,000 hours) over a 5 year service life when used in Enterprise Storage field conditions as limited by the following:

- 8760 power-on hours per year.
- HDA temperature as reported by the drive ≤ 40°C
- Ambient wet bulb temp ≤ 26°C
- Typical workload
- The AFR (MTBF) is a population statistic not relevant to individual units
- ANSI/ISA S71.04-2013 G2 classification levels and dust contamination to ISO 14644-1 Class 8 standards (as measured at the device)

The MTBF specification for the drive assumes the operating environment is designed to maintain nominal drive temperature and humidity. Occasional excursions in operating conditions between the rated MTBF conditions and the maximum drive operating conditions may occur without significant impact to the rated MTBF. However continual or sustained operation beyond the rated MTBF conditions will degrade the drive MTBF and reduce product reliability.

Nonrecoverable read errors	1 per 10 <sup>15</sup> bits read, max
Load unload cycles (command controlled)	600,000 cycles
Maximum Rated Workload	Maximum rate of <180TB/year Workloads exceeding the annualized rate may degrade the drive MTBF and impact product reliability. The Annualized Workload Rate is in units of TB per year, or TB per 8760 power on hours. Workload Rate = TB transferred * (8760 / recorded power on hours).
Warranty	To determine the warranty for a specific drive, use a web browser to access the following web page: <a href="http://www.seagate.com/support/warranty-and-replacements/">www.seagate.com/support/warranty-and-replacements/</a> . From this page, click on the "Is my Drive under Warranty" link. The following are required to be provided: the drive serial number, model number (or part number) and country of purchase. The system will display the warranty information for the drive.
Preventive maintenance	None required.

## 2.10 HDD and SSD Regulatory Compliance and Safety

For the latest regulatory and compliance information see: [www.seagate.com/support/](http://www.seagate.com/support/) scroll down the page to the Compliance, Safety and Disposal Guide link.

### 2.10.1 Regulatory models

The following regulatory model number represent all features and configurations within the series:

STR00C = ST6000VN001  
 SKR006 = ST4000VN006 & ST3000VN006 Models)  
 SKR001 = ST4000VN008 & ST3000VN007  
 VIDEO35HDD = ST2000VN004  
 STR009 = ST1000VN002

## 2.11 Corrosive environment

Seagate electronic drive components pass accelerated corrosion testing equivalent to 10 years exposure to light industrial environments containing sulfurous gases, chlorine and nitric oxide, classes G and H per ASTM B845. However, this accelerated testing cannot duplicate every potential application environment. Users should use caution exposing any electronic components to uncontrolled chemical pollutants and corrosive chemicals as electronic drive component reliability can be affected by the installation environment. The silver, copper, nickel and gold films used in Seagate products are especially sensitive to the presence of sulfide, chloride, and nitrate contaminants. Sulfur is found to be the most damaging. In addition, electronic components should never be exposed to condensing water on the surface of the printed circuit board assembly (PCBA) or exposed to an ambient relative humidity greater than 95%. Materials used in cabinet fabrication, such as vulcanized rubber, that can outgas corrosive compounds should be minimized or eliminated. The useful life of any electronic equipment may be extended by replacing materials near circuitry with sulfide-free alternatives.

## 2.12 Reference documents

Supported standards

Serial ATA Revision 3.3 specification

ANSI Documents

SFF-8301                      3.5" Drive Form Factor with Serial Connector  
 INCITS 522-2014            SCSI Protocol Layer-4 (SPL-4) Rev. 08

*Specification for Acoustic Test Requirement and Procedures*

Seagate part number: 30553-001

In case of conflict between this document and any referenced document, this document takes precedence.

## 2.13 Product warranty

Beginning on the date of shipment to the customer and continuing for the period specified in the purchase contract, Seagate warrants that each product (including components and subassemblies) that fails to function properly under normal use due to defect in materials or workmanship or due to nonconformance to the applicable specifications will be repaired or replaced, at Seagate's option and at no charge to the customer, if returned by customer at customer's expense to Seagate's designated facility in accordance with Seagate's warranty procedure. Seagate will pay for transporting the repair or replacement item to the customer. For more detailed warranty information, refer to the standard terms and conditions of purchase for Seagate products on the purchase documentation.

The remaining warranty for a particular drive can be determined by calling Seagate Customer Service at 1-800-468-3472. Users can also determine remaining warranty using the Seagate web site ([www.seagate.com](http://www.seagate.com)). The drive serial number is required to determine remaining warranty information.

### Shipping

When transporting or shipping a drive, use only a Seagate-approved container. Keep the original box. Seagate approved containers are easily identified by the Seagate Approved Package label. Shipping a drive in a non-approved container voids the drive warranty.

Seagate repair centers may refuse receipt of components improperly packaged or obviously damaged in transit. Contact the authorized Seagate distributor to purchase additional boxes. Seagate recommends shipping by an air-ride carrier experienced in handling computer equipment.

### Storage

Maximum storage periods are 180 days within original unopened Seagate shipping package or 60 days unpackaged within the defined non-operating limits (refer to environmental section in this manual). Storage can be extended to 1 year packaged or unpackaged under optimal environmental conditions (25°C, <40% relative humidity non-condensing, and non-corrosive environment). During any storage period the drive non-operational temperature, humidity, wet bulb, atmospheric conditions, shock, vibration, magnetic and electrical field specifications should be followed.

### Product repair and return information

Seagate customer service centers are the only facilities authorized to service Seagate drives. Seagate does not sanction any third-party repair facilities. Any unauthorized repair or tampering with the factory seal voids the warranty.

## 2.14 Seagate® Rescue™ Data Recovery Service

If you suffer a data loss event within the Seagate Rescue Data Recovery warranty period, and you are eligible to participate in and submit a case under the Rescue program, contact SRS at (1-800-723-1183) in the US, or if you are calling from outside the US please visit our website for numbers in your local and language: [www.seagate.com/contacts/contact-numbers/](http://www.seagate.com/contacts/contact-numbers/).

In addition, you may visit [rescueandreplace.seagate.com/contact.jsp](http://rescueandreplace.seagate.com/contact.jsp) to obtain information regarding how to contact a recovery expert online or by telephone from your location. An SRS representative will review your case to confirm your eligibility, and to assess whether your data may be recoverable by remote recovery services or whether you will need to send your device to SRS for in-lab servicing.

### Rescue™ General Terms

These Rescue™ General Terms together with the Rescue™ FAQ's make up the Rescue™ Program Terms. By submitting a case under the Rescue™ program ("Program") you agree to be bound by the Program Terms, including these General Terms and the FAQ. You must be a legal resident of the US to participate in the Program.

**Communications.** All communications relating to your request will be available on our web site in your account and sent via e-mail to the address you provide to us unless you request, in writing, to receive such communications via regular mail.

**Personal Data.** You must provide true, accurate and complete information about yourself as prompted by the request form, including, without limitation, your name, address, e-mail address, and telephone number, as applicable (collectively, "Personal Data"). You must maintain and promptly update your Personal Data. You acknowledge that we may send you important information and notices regarding your requests by e-mail and that we shall have no liability associated with or arising from your failure to maintain accurate Personal Data.

**Capacity; Legal Rights; Indemnity.** You represent to SRS that you are of the legal age of majority in your state or country of residence, with the full capacity to agree to these Program Terms. You warrant that you are the legal owner or the authorized representative of the legal owner of the device you submit to SRS (the "Device") and data. You warrant that the data on the Device is legal and that you have the unrestricted legal right to (a) give us remote access to the data, (b) have the data recovered and reproduced on a backup medium, (c) receive the recovered data, and (d) agree to these Program Terms. You will defend and indemnify us (including our directors, officers, employees, agents, delegates, and contractors) from any claims or actions relating to the Device or data, or your rights or lack of rights thereto.

**Confidentiality.** We will protect the confidentiality of your data against unauthorized disclosure using the same degree of care as we use to protect our own confidential information.

**Disclaimer of Warranties, Representations and Guarantees.** WE PROVIDE THE PROGRAM AND ANY SERVICES PROVIDED OR ATTEMPTED HEREUNDER "AS IS," WITH ALL FAULTS, AT YOUR SOLE RISK. WE DO NOT EXTEND ANY EXPRESS WARRANTIES, REPRESENTATIONS, CONDITIONS OR GUARANTEES REGARDING OUR RESCUE SERVICES OR ANY RESULTS THEREOF. TO THE MAXIMUM EXTENT PERMITTED BY APPLICABLE LAW AND SUBJECT TO ANY STATUTORY WARRANTIES THAT CANNOT BE EXCLUDED, WE EXPRESSLY DISCLAIM ALL IMPLIED WARRANTIES, INCLUDING ANY IMPLIED WARRANTY OR CONDITION OF MERCHANTABILITY, WARRANTY OF FITNESS FOR A PARTICULAR PURPOSE, OR WARRANTY OF ACCURACY OR COMPLETENESS WITH RESPECT TO THIS PROGRAM AND SERVICES. This Program and Disclaimer is unrelated to, and does not affect any warranties relating to your Device that we or the seller may have extended to you.

**Limitation of Liability.** WE WILL NOT BE LIABLE FOR ANY HARM CAUSED, UNLESS YOU PROVE THAT WE CAUSED SUCH HARM INTENTIONALLY. WITHOUT LIMITING THE GENERALITY OF THE FOREGOING, WE WILL NOT BE LIABLE FOR THE CONDITION, EXISTENCE, OR LOSS OF THE DATA YOU SEND US OR THE DATA WE RECOVER (IF ANY), ANY LOSS OF REVENUE OR LOSS OF PROFITS, OR ANY INDIRECT, SPECIAL, INCIDENTAL, OR CONSEQUENTIAL DAMAGES HOWEVER CAUSED. TO THE MAXIMUM EXTENT PERMITTED BY APPLICABLE LAW, THIS LIMITATION SHALL APPLY TO ANY AND ALL DAMAGES, REGARDLESS OF THE LEGAL THEORY ON WHICH THEY ARE ASSERTED (INCLUDING, WITHOUT LIMITATION, CONTRACT, BREACH OF CONTRACT, AND TORT), AND REGARDLESS OF WHETHER WE HAVE BEEN ADVISED OF THE POSSIBILITY OF LOSS OR DAMAGES - UNLESS YOU PROVE THAT SRS CAUSED DAMAGES TO YOU INTENTIONALLY. TO THE MAXIMUM EXTENT PERMITTED BY APPLICABLE LAW, THE AMOUNT OF OUR LIABILITY WILL NOT EXCEED THE TOTAL PRICE YOU ACTUALLY PAY FOR THE DEVICE, THE ESSENTIAL PURPOSE OF WHICH IS TO LIMIT OUR LIABILITY ARISING FROM OR RELATED TO THE PROGRAM AND ANY DATA RECOVERY SERVICES. THIS ALLOCATION OF RISK IS REFLECTED IN THE PRICE CHARGED FOR THIS PROGRAM OR SERVICES, IF ANY. YOU ACKNOWLEDGE THAT THE PRICE OF THIS PROGRAM WOULD BE MUCH GREATER IF WE UNDERTOOK MORE EXTENSIVE LIABILITY. THIS PARAGRAPH WILL APPLY NOTWITHSTANDING ANY OTHER PROVISIONS IN THESE TERMS, OR THE FAILURE OF ANY REMEDY.



**Compliance with Laws.** You agree to comply with all such laws and regulations and all other applicable laws, statutes, ordinances and regulations relating to the Program. You acknowledge that violations of these Program Terms could subject you to criminal or civil penalties. The goods licensed or provided, or services provided, through the Program, which may include technology and software, are subject to the customs and export control laws and regulations of the U.S. and may also be subject to the customs and export laws and regulations of the country in which the products are manufactured or received. Further, under U.S. law, such goods may not be sold, leased or otherwise transferred to restricted countries, or used by a restricted end-user or an end-user engaged in activities related to weapons of mass destruction including, without limitation, activities related to designing, developing, producing or using nuclear weapons, materials, or facilities, missiles or supporting missile projects, or chemical or biological weapons. You acknowledge you are not a restricted end-user or involved in any of the restricted activities above, and that you will comply with and abide by these laws and regulations. Seagate reserves the right to refuse service to or the return of any storage devices that have been determined to violate these regulations.

**Cancellation.** You may cancel the Program at any time by contacting SRS at 1-800-SEAGATE (1-800-475-0143) in the US, or at such other number available at [services.seagate.com/contact.aspx](https://services.seagate.com/contact.aspx), or you simply may refrain from submitting a request for Rescue services. These Program Terms remain applicable to your and SRS's rights and obligations with respect to any services requested by you under this Program.

**Assignment.** You may not assign your rights or obligations under these Program Terms without SRS' express written consent.

**Dispute Resolution.** The parties will attempt to resolve any dispute arising out of or related to these Program Terms or any data recovery services requested or attempted hereunder through good faith negotiation. To the extent permitted by applicable law, if the parties are unable to resolve the dispute through good faith negotiation, then the dispute will be submitted to final and binding arbitration with the Judicial Arbitration and Mediation Services. Each party will bear its own costs in arbitration, provided that Seagate reserves the right, in its discretion, to pre-pay certain fees you may incur in connection with the arbitration subject to refund if you do not prevail. **Both parties waive their rights to a jury trial.** All proceedings will take place in Santa Clara County, California, USA. The laws of the State of California will exclusively govern these Program Terms and our provision of any data recovery services, without regard to California's conflicts of laws rules. You consent to the exclusive jurisdiction of the courts located in Santa Clara County, California, USA.

**Severability.** If any provision of these Program Terms is held invalid, illegal or unenforceable, such provision shall be enforced to the fullest extent permitted by applicable law and the validity, legality and enforceability of the remaining provisions shall not be affected thereby.

**Legal Effect.** These Program Terms describe certain legal rights. You may have other rights under applicable law. These Program Terms do not change your rights under applicable law if such laws do not permit these Program Terms to do so. Also, the Program and these Program Terms are in addition and unrelated to any rights you may have under a Seagate warranty statement.

**SRS Companies.** The following SRS companies may provide the services described in these Program Terms: (a) Seagate Technology LLC, with offices at 3101 Jay Street, Suite 110, Santa Clara, California 95054; (b) Seagate Technology Canada Inc., with offices at 2421 Bristol Circle, Suite A100, Oakville, Ontario, Canada L6H 5S9; and/or (c) Seagate Technology (Netherlands) B.V., with offices at Koolhovenlaan 1, 1119 PA, Schiphol-Rijk, The Netherlands.

## 3.0 Configuring and Mounting the Drive

This section contains the specifications and instructions for configuring and mounting the drive.

### 3.1 Handling and static-discharge precautions

After unpacking, and before installation, the drive may be exposed to potential handling and electrostatic discharge (ESD) hazards. Observe the following standard handling and static-discharge precautions:

#### Caution

- Before handling the drive, put on a grounded wrist strap, or ground oneself frequently by touching the metal chassis of a computer that is plugged into a grounded outlet. Wear a grounded wrist strap throughout the entire installation procedure.
- Handle the drive by its edges or frame *only*.
- The drive is extremely fragile—handle it with care. Do not press down on the drive top cover.
- Always rest the drive on a padded, antistatic surface until mounting it in the computer.
- Do not touch the connector pins or the printed circuit board.
- Do not remove the factory-installed labels from the drive or cover them with additional labels. Removal voids the warranty. Some factory-installed labels contain information needed to service the drive. Other labels are used to seal out dirt and contamination.

### 3.2 Configuring the drive

Each drive on the SATA interface connects point-to-point with the SATA host adapter. There is no master/slave relationship because each drive is considered a master in a point-to-point relationship. If two drives are attached on one SATA host adapter, the host operating system views the two devices as if they were both “masters” on two separate ports. Both drives behave as if they are Device 0 (master) devices.

SATA drives are designed for easy installation. It is usually not necessary to set any jumpers on the drive for proper operation; however, if users connect the drive and receive a “drive not detected” error, the SATA-equipped motherboard or host adapter may use a chipset that does not support SATA speed autonegotiation.

### 3.3 SATA cables and connectors

The SATA interface cable consists of four conductors in two differential pairs, plus three ground connections. The cable size may be 30 to 26 AWG with a maximum length of one meter (39.37 inches). See [Table 9](#) for connector pin definitions. Either end of the SATA signal cable can be attached to the drive or host.

For direct backplane connection, the drive connectors are inserted directly into the host receptacle. The drive and the host receptacle incorporate features that enable the direct connection to be hot pluggable and blind mateable.

For installations which require cables, users can connect the drive as illustrated in [Figure 2](#).

**Figure 2 Attaching SATA cabling**

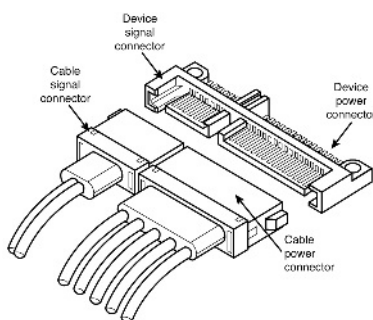

Each cable is keyed to ensure correct orientation. IronWolf drives support latching SATA connectors.

### 3.4 Drive mounting

Users can mount the drive in any orientation using four screws in the side-mounting holes or four screws in the bottom-mounting holes. Refer to **Figure 3** through **Figure 6** for drive mounting dimensions. Follow these important mounting precautions when mounting the drive:

- Allow a minimum clearance of 0.030 inches (0.76mm) around the entire perimeter of the drive for cooling.
- Use only 6-32 UNC mounting screws.
- The screws should be inserted no more than 0.140 inch (3.56mm) into the bottom or side mounting holes.
- Do not overtighten the mounting screws (maximum torque: 6 inch-lb).

**Figure 3 Mounting dimensions (6TB)**

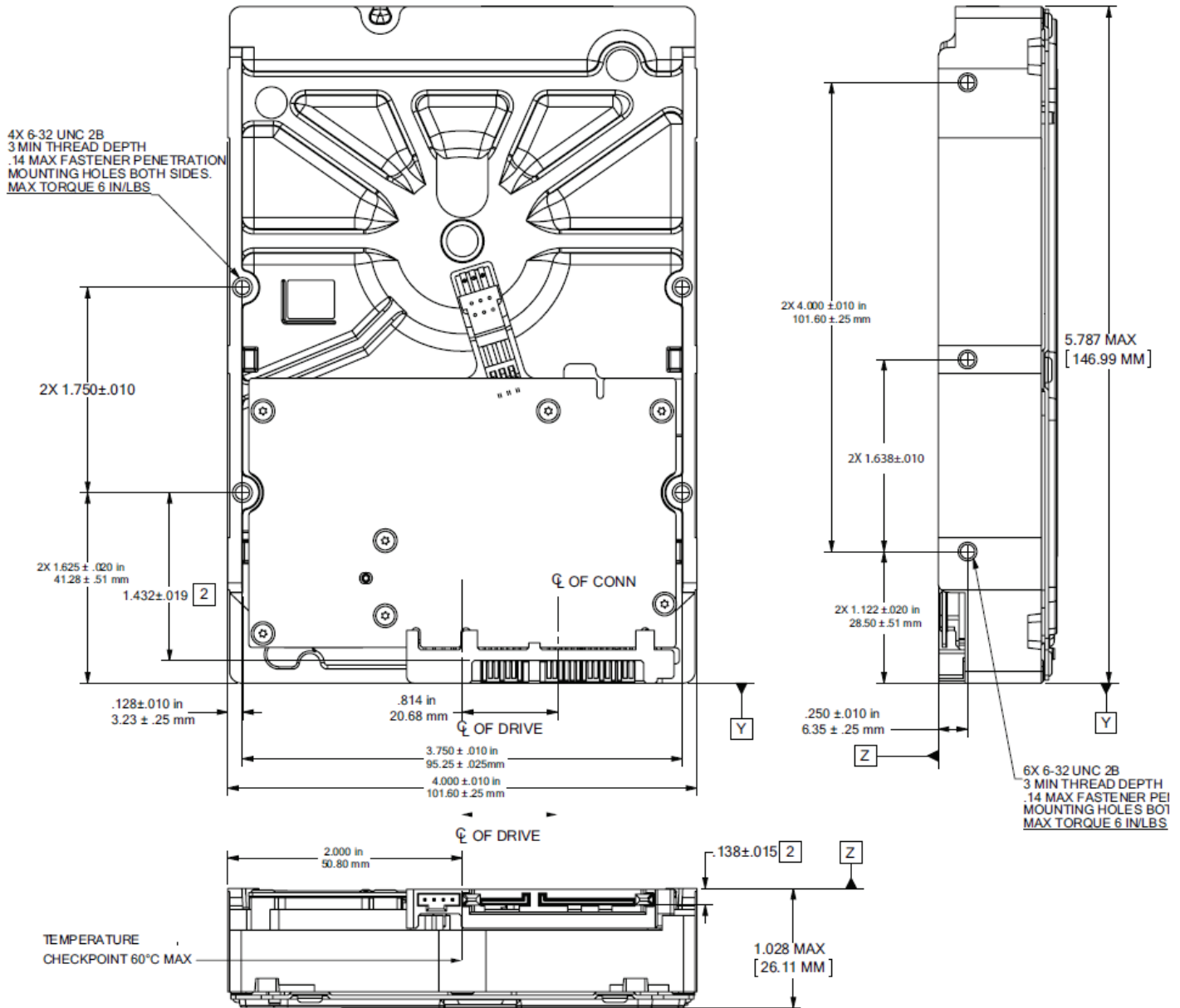

Figure 4 Mounting dimensions (ST4000VN008, ST4000VN006 & ST3000VN006 models)

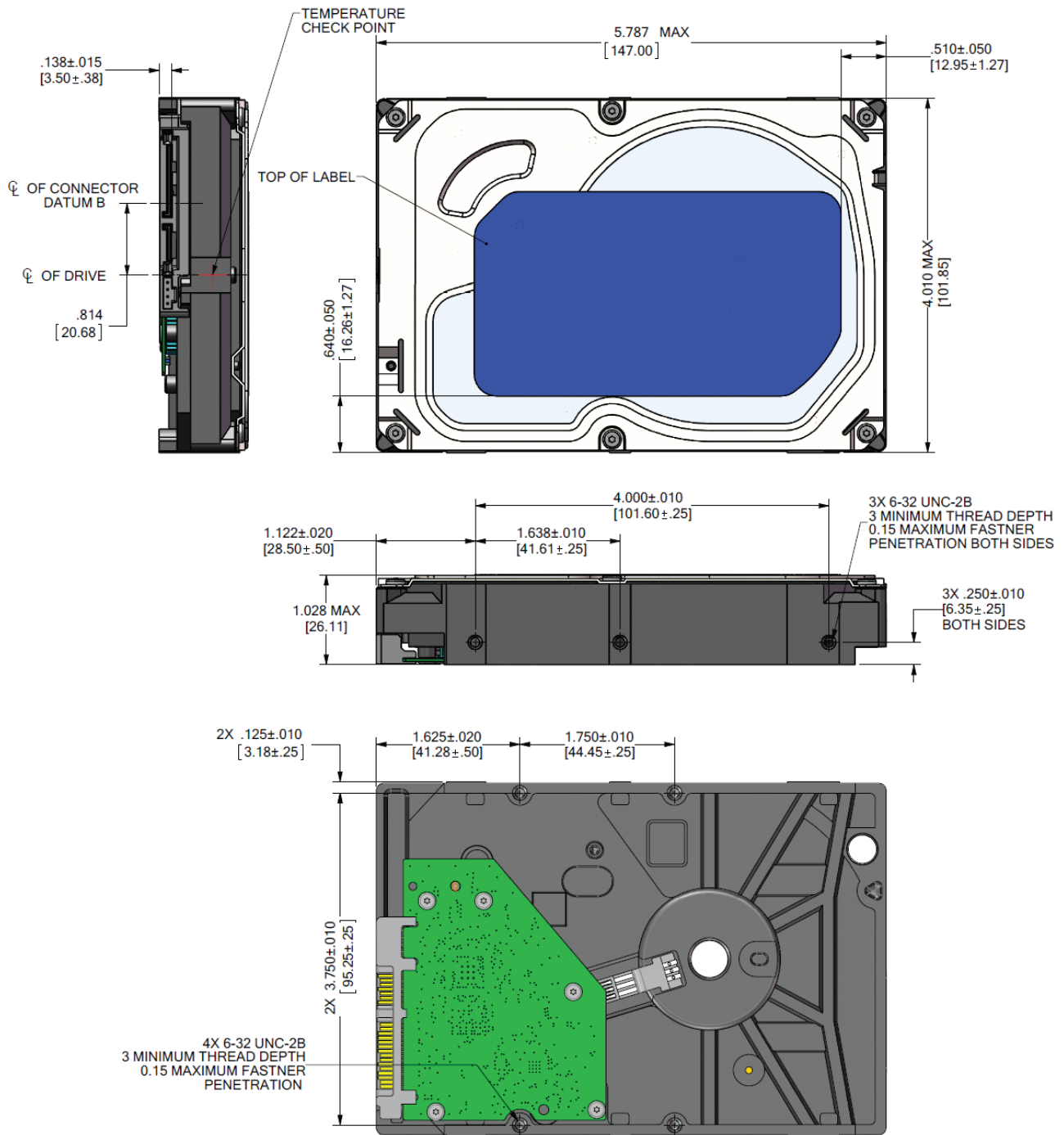

Figure 5 Mounting dimensions (ST3000VN007 & ST2000VN004 models)

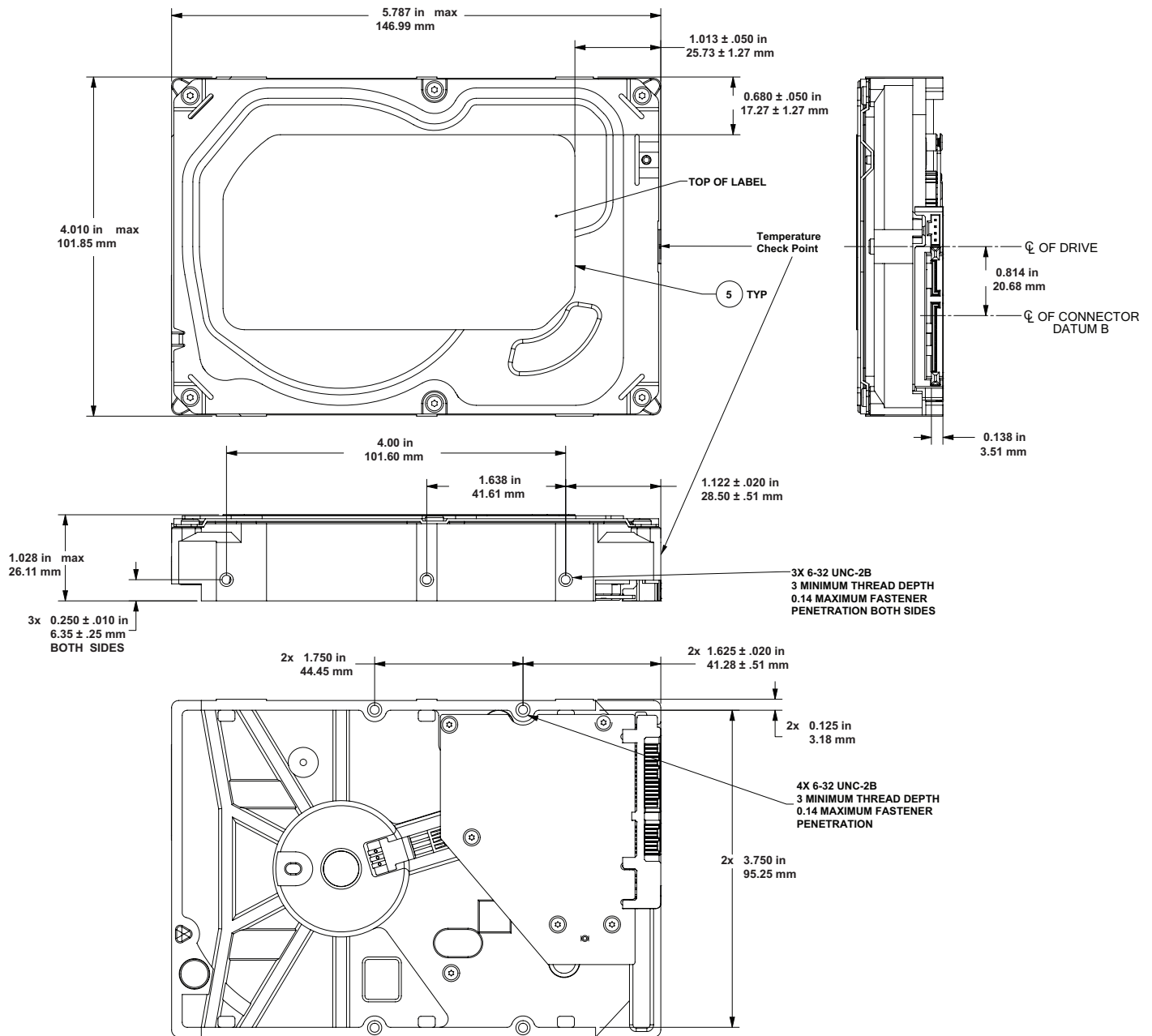
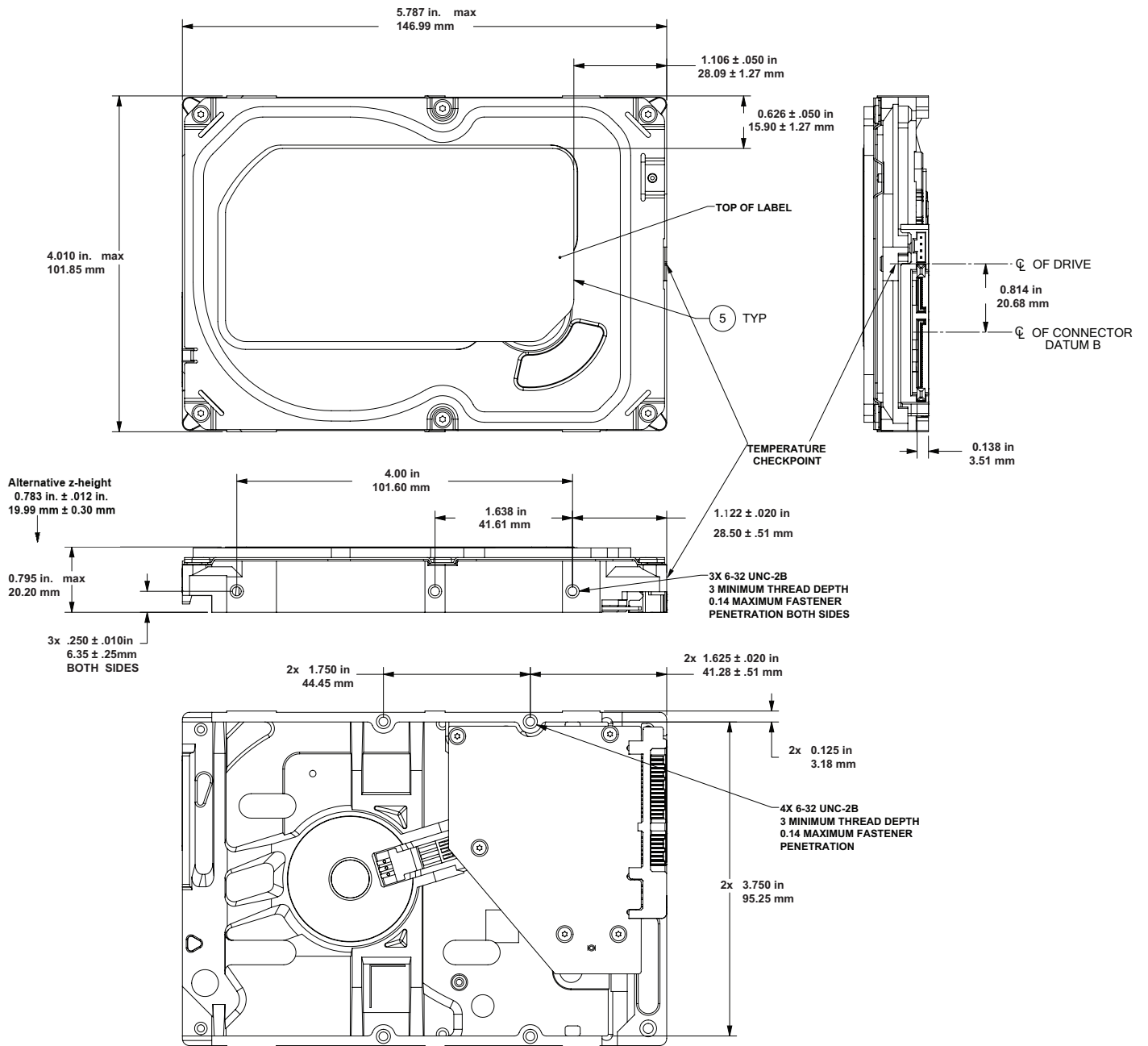

Figure 6 Mounting dimensions (1TB)



## 4.0 SATA Interface

These drives use the industry-standard Serial ATA (SATA) interface that supports FIS data transfers. It supports ATA programmed input/output (PIO) modes 0 to 4; multiword DMA modes 0 to 2, and Ultra DMA modes 0 to 6.

For detailed information about the SATA interface, refer to the “Serial ATA: High Speed Serialized AT Attachment” specification.

### 4.1 Hot-Plug compatibility

IronWolf drives incorporate connectors which enable users to hot plug these drives in accordance with the SATA Revision 3.2 specification. This specification can be downloaded from [www.serialata.org](http://www.serialata.org).

### 4.2 SATA device plug connector pin definitions

**Table 9** summarizes the signals on the SATA interface and power connectors.

**Table 9** SATA connector pin definitions

Segment	Pin	Function	Definition
Signal	S1	Ground	2nd mate
	S2	A+	Differential signal pair A from Phy
	S3	A-	
	S4	Ground	2nd mate
	S5	B-	Differential signal pair B from Phy
	S6	B+	
	S7	Ground	2nd mate
<b>Key and spacing separate signal and power segments</b>			
Power	P1	V <sub>33</sub>	3.3V power
	P2	V <sub>33</sub>	3.3V power
	P3	V <sub>33</sub>	3.3V power, pre-charge, 2nd mate
	P4	Ground	1st mate
	P5	Ground	2nd mate
	P6	Ground	2nd mate
	P7	V <sub>5</sub>	5V power, pre-charge, 2nd mate
	P8	V <sub>5</sub>	5V power
	P9	V <sub>5</sub>	5V power
	P10	Ground	2nd mate
	P11	Ground or LED signal	If grounded, drive does not use deferred spin
	P12	Ground	1st mate.
	P13	V <sub>12</sub>	12V power, pre-charge, 2nd mate
	P14	V <sub>12</sub>	12V power
	P15	V <sub>12</sub>	12V power

#### Notes

- All pins are in a single row, with a 1.27 mm (0.050 in) pitch.
- The comments on the mating sequence apply to the case of backplane blindmate connector only. In this case, the mating sequences are:
  - the ground pins P4 and P12.
  - the pre-charge power pins and the other ground pins.
  - the signal pins and the rest of the power pins.
- There are three power pins for each voltage. One pin from each voltage is used for pre-charge when installed in a blind-mate backplane configuration.
  - All used voltage pins (V<sub>x</sub>) must be terminated.

### 4.3 Supported ATA commands

The following table lists SATA standard commands that the drive supports.

For a detailed description of the ATA commands, refer to the Serial ATA International Organization: Serial ATA Revision 3.2 ([www.sata-io.org](http://www.sata-io.org)).

See “S.M.A.R.T. commands” on page 38 for details and subcommands used in the S.M.A.R.T. implementation.

**Table 10** SATA standard commands

Command name	Command code (in hex)
Check Power Mode	E5 <sub>H</sub>
Device Configuration Freeze Lock	B1 <sub>H</sub> / C1 <sub>H</sub>
Device Configuration Identify	B1 <sub>H</sub> / C2 <sub>H</sub>
Device Configuration Restore	B1 <sub>H</sub> / C0 <sub>H</sub>
Device Configuration Set	B1 <sub>H</sub> / C3 <sub>H</sub>
Device Reset	08 <sub>H</sub>
Download Microcode	92 <sub>H</sub>
Execute Device Diagnostics	90 <sub>H</sub>
Flush Cache	E7 <sub>H</sub>
Flush Cache Extended	EA <sub>H</sub>
Format Track	50 <sub>H</sub>
Identify Device	EC <sub>H</sub>
Idle	E3 <sub>H</sub>
Idle Immediate	E1 <sub>H</sub>
Initialize Device Parameters	91 <sub>H</sub>
Read Buffer	E4 <sub>H</sub>
Read DMA	C8 <sub>H</sub>
Read DMA Extended	25 <sub>H</sub>
Read DMA Without Retries	C9 <sub>H</sub>
Read Log Ext	2F <sub>H</sub>
Read Multiple	C4 <sub>H</sub>
Read Multiple Extended	29 <sub>H</sub>
Read Native Max Address	F8 <sub>H</sub>
Read Native Max Address Extended	27 <sub>H</sub>
Read Sectors	20 <sub>H</sub>
Read Sectors Extended	24 <sub>H</sub>
Read Sectors Without Retries	21 <sub>H</sub>
Read Verify Sectors	40 <sub>H</sub>
Read Verify Sectors Extended	42 <sub>H</sub>
Read Verify Sectors Without Retries	41 <sub>H</sub>
Recalibrate	10 <sub>H</sub>
Security Disable Password	F6 <sub>H</sub>
Security Erase Prepare	F3 <sub>H</sub>
Security Erase Unit	F4 <sub>H</sub>
Security Freeze	F5 <sub>H</sub>
Security Set Password	F1 <sub>H</sub>
Security Unlock	F2 <sub>H</sub>
Seek	70 <sub>H</sub>



Table 10 SATA standard commands (continued)

Command name	Command code (in hex)	
Set Features	EF <sub>H</sub>	
Set Max Address	F9 <sub>H</sub>	
<b>Note:</b> Individual Set Max Address commands are identified by the value placed in the Set Max Features register as defined to the right.	Address:	00 <sub>H</sub>
	Password:	01 <sub>H</sub>
	Lock:	02 <sub>H</sub>
	Unlock:	03 <sub>H</sub>
	Freeze Lock:	04 <sub>H</sub>
Set Max Address Extended	37 <sub>H</sub>	
Set Multiple Mode	C6 <sub>H</sub>	
Sleep	E6 <sub>H</sub>	
S.M.A.R.T. Disable Operations	B0 <sub>H</sub> / D9 <sub>H</sub>	
S.M.A.R.T. Enable/Disable Autosave	B0 <sub>H</sub> / D2 <sub>H</sub>	
S.M.A.R.T. Enable Operations	B0 <sub>H</sub> / D8 <sub>H</sub>	
S.M.A.R.T. Execute Offline	B0 <sub>H</sub> / D4 <sub>H</sub>	
S.M.A.R.T. Read Attribute Thresholds	B0 <sub>H</sub> / D1 <sub>H</sub>	
S.M.A.R.T. Read Data	B0 <sub>H</sub> / D0 <sub>H</sub>	
S.M.A.R.T. Read Log Sector	B0 <sub>H</sub> / D5 <sub>H</sub>	
S.M.A.R.T. Return Status	B0 <sub>H</sub> / DA <sub>H</sub>	
S.M.A.R.T. Save Attribute Values	B0 <sub>H</sub> / D3 <sub>H</sub>	
S.M.A.R.T. Write Log Sector	B0 <sub>H</sub> / D6 <sub>H</sub>	
Standby	E2 <sub>H</sub>	
Standby Immediate	E0 <sub>H</sub>	
Write Buffer	E8 <sub>H</sub>	
Write DMA	CA <sub>H</sub>	
Write DMA Extended	35 <sub>H</sub>	
Write DMA FUA Extended	3D <sub>H</sub>	
Write DMA Without Retries	CB <sub>H</sub>	
Write Log Extended	3F <sub>H</sub>	
Write Multiple	C5 <sub>H</sub>	
Write Multiple Extended	39 <sub>H</sub>	
Write Multiple FUA Extended	CE <sub>H</sub>	
Write Sectors	30 <sub>H</sub>	
Write Sectors Without Retries	31 <sub>H</sub>	
Write Sectors Extended	34 <sub>H</sub>	
Write Uncorrectable	45 <sub>H</sub>	

### 4.3.1 Identify Device command

The Identify Device command (command code EC<sub>H</sub>) transfers information about the drive to the host following power up. The data is organized as a single 512-byte block of data, whose contents are shown in [Table 10 on page 31](#). All reserved bits or words should be set to zero. Parameters listed with an “x” are drive-specific or vary with the state of the drive.

The following commands contain drive-specific features that may not be included in the SATA specification.

**Table 11 Identify Device commands**

Word	Description	Value
0	Configuration information: • Bit 15: 0 = ATA; 1 = ATAPI • Bit 7: removable media • Bit 6: removable controller • Bit 0: reserved	0C5A <sub>H</sub>
1	Number of logical cylinders	16,383
2	ATA-reserved	0000 <sub>H</sub>
3	Number of logical heads	16
4	Retired	0000 <sub>H</sub>
5	Retired	0000 <sub>H</sub>
6	Number of logical sectors per logical track: 63	003F <sub>H</sub>
7–9	Retired	0000 <sub>H</sub>
10–19	Serial number: (20 ASCII characters, 0000 <sub>H</sub> = none)	ASCII
20	Retired	0000 <sub>H</sub>
21	Retired	0400 <sub>H</sub>
22	Obsolete	0000 <sub>H</sub>
23–26	Firmware revision (8 ASCII character string, padded with blanks to end of string)	x.xx
27–46	Drive model number: (40 ASCII characters, padded with blanks to end of string)	
47	(Bits 7–0) Maximum sectors per interrupt on Read multiple and Write multiple (16)	8010 <sub>H</sub>
48	Reserved	0000 <sub>H</sub>
49	Standard Standby timer, IORDY supported and may be disabled	2F00 <sub>H</sub>
50	ATA-reserved	0000 <sub>H</sub>
51	PIO data-transfer cycle timing mode	0200 <sub>H</sub>
52	Retired	0200 <sub>H</sub>
53	Words 54–58, 64–70 and 88 are valid	0007 <sub>H</sub>
54	Number of current logical cylinders	xxxx <sub>H</sub>
55	Number of current logical heads	xxxx <sub>H</sub>
56	Number of current logical sectors per logical track	xxxx <sub>H</sub>
57–58	Current capacity in sectors	xxxx <sub>H</sub>
59	Number of sectors transferred during a Read Multiple or Write Multiple command	xxxx <sub>H</sub>

Table 11 Identify Device commands (continued)

Word	Description	Value
60–61	Total number of user-addressable LBA sectors available (see <a href="#">Section 2.2</a> for related information) <b>*Note:</b> The maximum value allowed in this field is: 0FFFFFFFh (268,435,455 sectors, 137GB). Drives with capacities over 137GB will have 0FFFFFFFh in this field and the actual number of user-addressable LBAs specified in words 100-103. This is required for drives that support the 48-bit addressing feature.	0FFFFFFFh*
62	Retired	0000 <sub>H</sub>
63	Multiword DMA active and modes supported (see note following this table)	xx07 <sub>H</sub>
64	Advanced PIO modes supported (modes 3 and 4 supported)	0003 <sub>H</sub>
65	Minimum multiword DMA transfer cycle time per word (120 nsec)	0078 <sub>H</sub>
66	Recommended multiword DMA transfer cycle time per word (120 nsec)	0078 <sub>H</sub>
67	Minimum PIO cycle time without IORDY flow control (240 nsec)	0078 <sub>H</sub>
68	Minimum PIO cycle time with IORDY flow control (120 nsec)	0078 <sub>H</sub>
69–74	ATA-reserved	0000 <sub>H</sub>
75	Queue depth	001F <sub>H</sub>
76	SATA capabilities	xxxx <sub>H</sub>
77	Reserved for future SATA definition	xxxx <sub>H</sub>
78	SATA features supported	xxxx <sub>H</sub>
79	SATA features enabled	xxxx <sub>H</sub>
80	Major version number	01F0 <sub>H</sub>
81	Minor version number	0028 <sub>H</sub>
82	Command sets supported	364B <sub>H</sub>
83	Command sets supported	7F09 <sub>H</sub>
84	Command sets support extension (see note following this table)	4163 <sub>H</sub>
85	Command sets enabled	30xx <sub>H</sub>
86	Command sets enabled	BE09 <sub>H</sub>
87	Command sets enable extension	4163 <sub>H</sub>
88	Ultra DMA support and current mode (see note following this table)	xx7F <sub>H</sub>
89	Security erase time	0039 <sub>H</sub>
90	Enhanced security erase time	0039 <sub>H</sub>
92	Master password revision code	FFFE <sub>H</sub>
93	Hardware reset value	xxxx <sub>H</sub>
94	Automatic acoustic management	8080 <sub>H</sub>
95	Stream Min. Request Size	0000 <sub>H</sub>
96	Streaming Transfer Time - DMA	0000 <sub>H</sub>
97	Streaming Access Latency - DMA and PIO	0000 <sub>H</sub>
98–99	Streaming Performance Granularity	0000 <sub>H</sub>

**Table 11 Identify Device commands (continued)**

Word	Description	Value
100–103	Total number of user-addressable LBA sectors available (see <a href="#">Section 2.2</a> for related information). These words are required for drives that support the 48-bit addressing feature. Maximum value: 0000FFFFFFFFFh.	ST1000VN002 = 1,953,525,168 ST2000VN004 = 3,907,029,168 ST3000VN006 = 5,860,533,168 ST3000VN007 = 5,860,533,168 ST4000VN006 = 7,814,037,168 ST4000VN008 = 7,814,037,168 ST6000VN001 = 11,721,045,168
104	Streaming Transfer Time - PIO	0000 <sub>H</sub>
105–107	ATA-reserved	0000 <sub>H</sub>
108–111	The mandatory value of the world wide name (WWN) for the drive. <b>NOTE:</b> This field is valid if word 84, bit 8 is set to 1 indicating 64-bit WWN support.	Each drive will have a unique value.
112–127	ATA-reserved	0000 <sub>H</sub>
128	Security status	0001 <sub>H</sub>
129–159	Seagate-reserved	xxxx <sub>H</sub>
160–254	ATA-reserved	0000 <sub>H</sub>
255	Integrity word	xxA5 <sub>H</sub>

**Note**

Advanced Power Management (APM) and Automatic Acoustic Management (AAM) features are not supported.

**Note**

See the bit descriptions below for words 63, 84, and 88 of the Identify Drive data.

<b>Description (if bit is set to 1)</b>	
<b>Bit</b>	<b>Word 63</b>
0	Multiword DMA mode 0 is supported.
1	Multiword DMA mode 1 is supported.
2	Multiword DMA mode 2 is supported.
8	Multiword DMA mode 0 is currently active.
9	Multiword DMA mode 1 is currently active.
10	Multiword DMA mode 2 is currently active.
<b>Bit</b>	<b>Word 84</b>
0	SMART error login is supported.
1	SMART self-test is supported.
2	Media serial number is supported.
3	Media Card Pass Through Command feature set is supported.
4	Streaming feature set is supported.
5	GPL feature set is supported.
6	WRITE DMA FUA EXT and WRITE MULTIPLE FUA EXT commands are supported.
7	WRITE DMA QUEUED FUA EXT command is supported.
8	64-bit World Wide Name is supported.
9-10	Obsolete.
11-12	Reserved for TLC.
13	IDLE IMMEDIATE command with IUNLOAD feature is supported.
14	Shall be set to 1.
15	Shall be cleared to 0.
<b>Bit</b>	<b>Word 88</b>
0	Ultra DMA mode 0 is supported.
1	Ultra DMA mode 1 is supported.
2	Ultra DMA mode 2 is supported.
3	Ultra DMA mode 3 is supported.
4	Ultra DMA mode 4 is supported.
5	Ultra DMA mode 5 is supported.
6	Ultra DMA mode 6 is supported.
8	Ultra DMA mode 0 is currently active.
9	Ultra DMA mode 1 is currently active.
10	Ultra DMA mode 2 is currently active.
11	Ultra DMA mode 3 is currently active.
12	Ultra DMA mode 4 is currently active.
13	Ultra DMA mode 5 is currently active.
14	Ultra DMA mode 6 is currently active.

### 4.3.2 Set Features command

This command controls the implementation of various features that the drive supports. When the drive receives this command, it sets BSY, checks the contents of the Features register, clears BSY and generates an interrupt. If the value in the register does not represent a feature that the drive supports, the command is aborted. Power-on default has the read look-ahead and write caching features enabled. The acceptable values for the Features register are defined as follows:

**Table 12 Set Features commands**

02 <sub>H</sub>	Enable write cache ( <i>default</i> ).
03 <sub>H</sub>	Set transfer mode (based on value in Sector Count register). Sector Count register values:
	00 <sub>H</sub> Set PIO mode to default (PIO mode 2).
	01 <sub>H</sub> Set PIO mode to default and disable IORDY (PIO mode 2).
	08 <sub>H</sub> PIO mode 0
	09 <sub>H</sub> PIO mode 1
	0A <sub>H</sub> PIO mode 2
	0B <sub>H</sub> PIO mode 3
	0C <sub>H</sub> PIO mode 4 ( <i>default</i> )
	20 <sub>H</sub> Multiword DMA mode 0
	21 <sub>H</sub> Multiword DMA mode 1
	22 <sub>H</sub> Multiword DMA mode 2
	40 <sub>H</sub> Ultra DMA mode 0
	41 <sub>H</sub> Ultra DMA mode 1
	42 <sub>H</sub> Ultra DMA mode 2
	43 <sub>H</sub> Ultra DMA mode 3
	44 <sub>H</sub> Ultra DMA mode 4
	45 <sub>H</sub> Ultra DMA mode 5
	46 <sub>H</sub> Ultra DMA mode 6
06 <sub>H</sub>	Enable the PUIS feature set
07 <sub>H</sub>	PUIS feature set device spin-up
10 <sub>H</sub>	Enable use of SATA features
55 <sub>H</sub>	Disable read look-ahead (read cache) feature
82 <sub>H</sub>	Disable write cache
86 <sub>H</sub>	Disable the PUIS feature set
90 <sub>H</sub>	Disable use of SATA features
AA <sub>H</sub>	Enable read look-ahead (read cache) feature ( <i>default</i> ).
F1 <sub>H</sub>	Report full capacity available

**Note**

At power-on, or after a hardware or software reset, the default values of the features are as indicated above.

### 4.3.3 S.M.A.R.T. commands

S.M.A.R.T. provides near-term failure prediction for disk drives. When S.M.A.R.T. is enabled, the drive monitors predetermined drive attributes that are susceptible to degradation over time. If self-monitoring determines that a failure is likely, S.M.A.R.T. makes a status report available to the host. Not all failures are predictable. S.M.A.R.T. predictability is limited to the attributes the drive can monitor. For more information on S.M.A.R.T. commands and implementation, see the *Draft ATA-5 Standard*.

SeaTools diagnostic software activates a built-in drive self-test (DST S.M.A.R.T. command for D4<sub>H</sub>) that eliminates unnecessary drive returns. The diagnostic software ships with all new drives and is also available at: [seatools.seagate.com](http://seatools.seagate.com).

This drive is shipped with S.M.A.R.T. features enabled. **Table 13** below shows the S.M.A.R.T. command codes that the drive uses.

**Table 13 S.M.A.R.T. commands**

Code in features register	S.M.A.R.T. command
D0 <sub>H</sub>	S.M.A.R.T. Read Data
D2 <sub>H</sub>	S.M.A.R.T. Enable/Disable Attribute Autosave
D3 <sub>H</sub>	S.M.A.R.T. Save Attribute Values
D4 <sub>H</sub>	S.M.A.R.T. Execute Off-line Immediate (runs DST)
D5 <sub>H</sub>	S.M.A.R.T. Read Log Sector
D6 <sub>H</sub>	S.M.A.R.T. Write Log Sector
D8 <sub>H</sub>	S.M.A.R.T. Enable Operations
D9 <sub>H</sub>	S.M.A.R.T. Disable Operations
DA <sub>H</sub>	S.M.A.R.T. Return Status

**Note**

If an appropriate code is not written to the Features Register, the command is aborted and 0x04 (abort) is written to the Error register.



**Seagate Technology LLC**

AMERICAS Seagate Technology LLC 47488 Kato Road, Fremont, California 94538, United States, 510-661-1000