

Stryker™ Lon Configurable VAV/CVAHU Controllers

INSTALLATION INSTRUCTIONS

APPLICATION

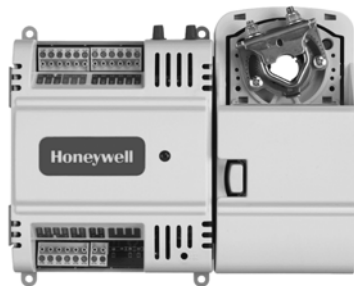
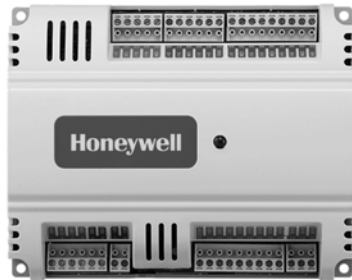

The Stryker™ configurable, direct digital controllers are used for either pressure-independent or pressure single-duct VAV terminal units OR constant volume, air-handling unit control solutions. VAV controllers feature preprogrammed heat/cooling or reheat algorithms for VAV box control applications and can be configured to match a wide range of VAV applications. The CVAHU controller is designed to control a wide range of air-handling units including single-zone and heat pump air handlers. All Stryker™ controllers use Echelon LONWORKS communication technology and the Free Topology Transceiver (FTT) for great installation flexibility.

One model of the CUL controller (CUL6438SR-CV1) and two models of the CVL controller (CVL4022AS-VAV1 and CVL4024NS-VAV1) are available. The CVL4022AS-VAV1 model consists of a VAV controller and a floating actuator. The CVL4024NS-VAV1 VAV controller model does not include an actuator. Both models contain an integral microbridge air flow sensor that provides flow measurement for pressure independent applications.

The CUL controller controls space temperature in a given zone by regulating heating and cooling equipment in the air handler delivering air to that space.

The CVL controller controls the space temperature in a given zone by modulating a damper and/or regulating a reheat coil in a Variable Air Volume Box that delivers air to one space.

The controllers are capable of stand-alone operation; however, optimum functional benefits are achieved when the network communication capabilities are used.

The Zio (TR71/75) wall modules are used in conjunction with the CUL and CVL controllers. Zio is an LCD Wall Module to communicate via a two-wire, polarity insensitive bus with the Honeywell Spyder and Stryker™ controller families. The CUL and CVL controllers can be configured in Zio.

Table 1. Controller Configurations

Controller Model	Communication Protocol	Application	UI (Universal Input)	DI (Digital Input)	AO (Analog Output)	DO (Digital Output)	Velocity Pressure Sensor (Microbridge)	Series 60 Floating Actuator
CVL4022AS-VAV1	LonWorks	VAV	4	0	2	2	YES	YES
CVL4024NS-VAV1	LonWorks	VAV	4	0	2	4	YES	NO
CUL6438SR-CV1	LonWorks	CVAHU	6	4	3	8 Relays	NO	NO



Specifications

Electrical

Rated Voltage: 20-30 Vac; 50/60 Hz

Power Consumption:

100 VA for controller and all connected loads

Controller only Load: 5 VA maximum for models CUL6438SR-CV1 and CVL4024NS-VAV1

Controller and Actuator Load: 9 VA maximum, model CVL4022AS-VAV1

External Sensors Power Output: 20 Vdc ±10% @ 75 mA maximum

Environmental

VAV Operating & Storage Temperature Ambient Rating (models CVL4022AS-VAV1 and CVL4024NS-VAV1):
Minimum 32° F (0° C); Maximum 122° F (50° C)

CVAHU Operating & Storage Temperature Ambient Rating (model CUL6438SR-CV1)
Minimum -40° F (-40° C); Maximum 150° F (65.5° C)

Relative Humidity: 5% to 95% non-condensing

Approval Bodies

UL/cUL (E87741) listed under UL916 (Standard for Open Energy Management Equipment) with plenum rating.

CSA (LR95329-3) listed.

Meets FCC Part 15, Subpart B, Class B (radiated emissions) requirements.

Meets Canadian standard C108.8 (radiated emissions).

Conforms to the following requirements per European Consortium standards:

- EN 61000-6-1; 2001 (EU Immunity).

- EN 61000-6-3; 2001 (EU Emissions)

Velocity Pressure Sensor (models CVL4022AS-VAV1 and CVL4024NS-VAV1)

Operating Range: 0 to 1.5 in. H₂O (0 to 374 Pa)

Series 60 Floating Actuator (model CVL4022AS-VAV1)

Rotation Stroke: 95° ± 3° for CW or CCW opening dampers

Torque Rating: 44 lb-in. (5 Nm)

Run Time for 90° rotation: 90 seconds at 60 Hz

Hardware

CPU: Each controller uses a Texas Instruments MSP430 family microprocessor. The processor contains on-chip FLASH program memory, FLASH information memory, and RAM.

Memory Capacity

Flash Memory: 116 kilobytes with 8 kilobytes available for user program. The controller is able to retain FLASH memory settings for up to ten (10) years.

RAM: 8 kilobytes

Dimensions

CUL6438SR-CV1: H/W/D: 5.45 x 6.85 x 2.26 in.
(13.84 x 17.40 x 5.74 cm)

CVL4022AS-VAV1: H/W/D: 6.60 x 8.28 x 2.26 in.
(16.7 x 21.1 x 5.7 cm)

CVL4024NS-VAV1: H/W/D: 6.60 x 4.75 x 2.26 in.
(15.9 x 12.1 x 5.7 cm)

Real Time Clock

Operating Range: 24 hour, 365 day, multi-year calendar including day of week and configuration for automatic daylight savings time adjustment to occur at 2:00 a.m. local time on configured start and stop dates.

Power Failure Backup: 24 hours at 32 to 100° F (0 to 38° C), 22 hours at 100 to 122° F (38 to 50° C)

Accuracy: ±1 minute per month at 77° F (25° C)

Inputs and Outputs

CVL4022AS-VAV1 has four universal input (UI) circuits, two analog outputs (AO), and two digital Triac outputs (DO). Two Digital Outputs are reserved for the actuator.

CVL4024NS-VAV1 has four universal input (UI) circuits, two analog outputs (AO), and four digital Triac outputs (DO).

CUL6438SR-CV1 has six universal inputs (UI), four digital inputs (DI), three analog outputs (AO), and eight digital relay outputs (DO).

Universal Input (UI) Circuits

See Table 2 for the UI specifications.

Table 2. Universal Input Circuit Specifications

Input Type	Sensor Type	Operating Range
Room/Zone Discharge Air Outdoor Air Temperature	20K Ohm NTC	-40° F to 199° F (-40° C to 93° C)
Outdoor Air Temperature	C7031G ^a	-40° to 120°F (-40° to 49°C)
	C7041F ^a	-40° to 250°F (-40° to 121°C)
	PT1000 (IEC751 3850)	-40° F to 199° F (-40° C to 93° C)
TR23 Setpoint Potentiometer	500 Ohm to 10,500 Ohm	-4° DDC to 4° DDC (-8° DDF to 7° DDF) or 50° F to 90° F (10° C to 32° C)
Resistive Input	Generic	100 Ohms to 100K Ohms
Voltage Input	Transducer, Controller	0–10 Vdc
Discrete Input	Dry Contact closure	OpenCircuit ≥ 3000Ohms ClosedCircuit < 3000Ohms

^a C7031G and C7041F are recommended for use with these controllers, due to improved resolution and accuracy when compared to the PT1000.

Analog Output (AO) Circuits

ANALOG CURRENT OUTPUTS:

Current Output Range: 4.0 to 20.0 mA

Output Load Resistance: 550 Ohms maximum

ANALOG VOLTAGE OUTPUTS:

Current Output Range: 4.0 to 20.0 mA

Output Load Resistance: 550 Ohms maximum

Digital Triac Output (DO) Circuits (CVL4022AS-VAV1 and CVL4024NS-VAV1 only)

Voltage Rating: 20 to 30 Vac @ 50-60Hz

Current Rating: 25 mA to 500 mA continuous, 800 mA (AC rms) for 60 milliseconds

Digital Relay Output (DO) Circuits (CUL6438SR-CV1 only)

Voltage Rating: 20 to 30 Vac @ 50-60Hz

Current Rating: 0 mA to 1 A continuous, 3.5 A inrush (AC rms) for 100 milliseconds

Status Information

The LED on the front of the controller provides a visual indication of the status of the device. When the controller receives power, the LED appears in one of the following allowable states, as described in Table 3.

Table 3. Status LED States.

LED State	Blink Rate	Status or Condition
OFF	not applicable	No power to processor, LED damaged, low voltage to board, or controller damaged.
ON	ON steady; not blinking	Processor and/or controller is not operating.
Very slow blink (continuous)	1 second ON, 1 second OFF	Controller is operating normally.
Slow blink (continuous)	0.5 second ON, 0.5 second OFF	Controller alarm is active, controller in process of download, or controller lost its configuration.
Medium blink (continuous)	0.25 second ON, 0.25 second OFF	Controller firmware is loading.
Fast blink (continuous)	0.10 second ON, 0.10 second OFF	Controller is in manual mode under control of the PC-based software tool.

Communications

Each controller uses an FTT transformer-coupled communications port. The controller's Manchester encoded data is presented to other controllers and devices on the LONWORKS® Bus at 78 kilobits per second (kbs) via Echelon® communication protocol. The transformer-coupled communications interface offers a much higher degree of common mode-noise rejection while assuring dc isolation. The LONWORKS® Bus is polarity insensitive, eliminating installation errors due to miswiring.

Sylk™ Bus

Sylk is a two wire, polarity insensitive bus that provides both 18 Vdc power and communications between Sylk-enabled devices. Using Sylk-enabled devices saves I/O on the controller and is faster and cheaper to install since only two wires are needed and the bus is polarity insensitive.

LONMARK® Functional Profile

The CVL Controllers support the LONMARK® Functional Profile number 8010 VAV Controller, version 1.0.

Network Variables Profile

Network variables, as described in Fig. 1 and 2, are communicated over the LONWORKS® Bus. The controller's built-in functions provide for the selection of variables, which are available from/to the network.

In Fig. 1 and 2 the network variable prefixes have the following meaning:

- nvi - Network Variable Input
- nvo - Network Variable Output

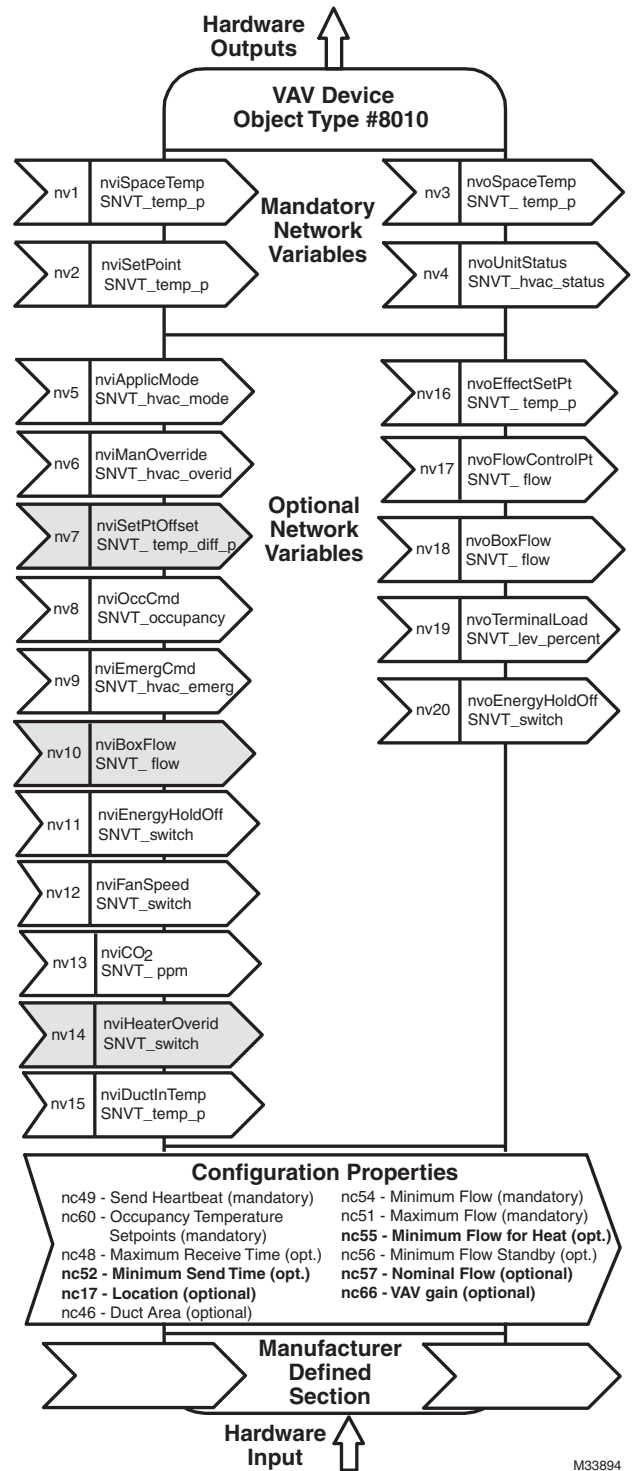

Fig. 1. Object Variables List for VAV controllers.

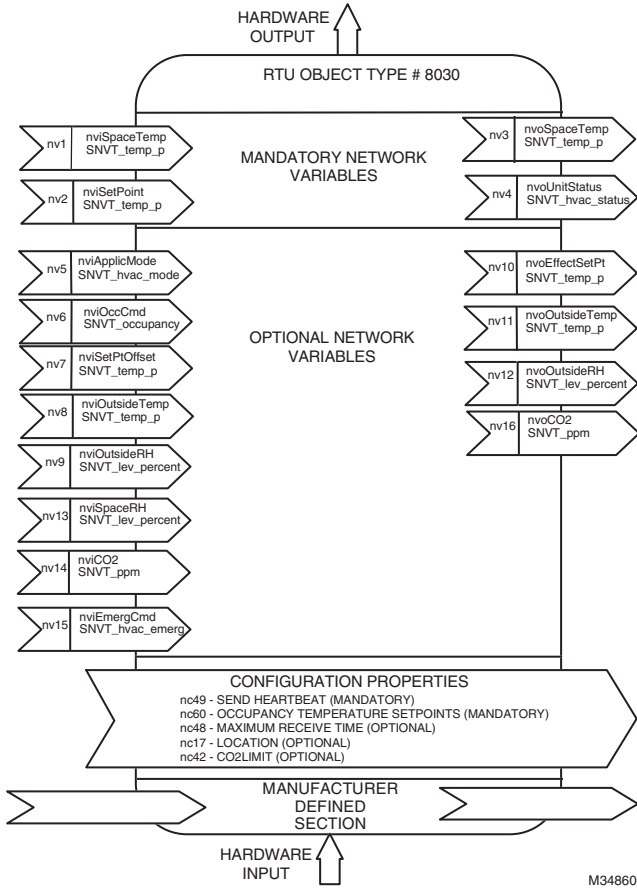

Fig. 2. Object variables for CVAHU controllers.

Accessories

- 201052A, B, C Auxiliary Switches (one, two or three switches)
- 209541B Termination Module
- C7041B, C, D, P, R Air Temperature Sensor (indoor)
- C7770A Air Temperature Sensor (indoor/plenum)
- C7031G Air Temperature Sensor (outdoor)
- C7041F Air Temperature Sensor (outdoor)
- Q7751A,B Router (configured as a repeater)
- Q7752A,B Serial Interface Adapter
- TR7X Wall Module
- TR2X Wall Module
- C7400A Enthalpy Sensor
- P7640 Pressure Transducer Family
- C7262 CO2 Sensor Family
- C7600 Humidity Sensor Family
- H7625, H7635, and H7655 Humidity and Temperature Sensors

Refer to the "Sensors Product Overview," form 63-9285, for additional accessories.

BEFORE INSTALLATION

Review the power, input, and output specifications on page "2" before installing the controller.

- Hardware driven by Triac outputs must have a minimum current draw, when energized, of 25 mA and a maximum current draw of 500 mA.
- Hardware driven by the analog current outputs must have a maximum resistance of 550 Ohms, resulting in a maximum voltage of 11 volts when driven at 20 mA.

If resistance exceeds 550 Ohms, voltages up to 18 Vdc are possible at the analog output terminal.

INSTALLATION

The controller must be mounted in a position that allows clearance for wiring, servicing, removal, connection of the LonWorks® Bus Jack, and access to the Neuron® Service Pin (see Fig. 16 on page 14). The controller may be mounted in any orientation.

IMPORTANT NOTE:

Avoid mounting in areas where acid fumes or other deteriorating vapors can attack the metal parts of the controller, or in areas where escaping gas or other explosive vapors are present (see Fig. 4-Fig. 5 on page 6 for mounting dimensions).

Mount Actuator onto Damper Shaft (CVL4022AS-VAV1 only)

The CVL4022AS-VAV1 controller includes the direct-coupled actuator with Declutch mechanism, which is shipped hard-wired to the controller. The actuator mounts directly onto the VAV box damper shaft and has up to 44 lb-in. (5 Nm) torque, 90-degree stroke, and 90 second timing at 60 Hz. The actuator is suitable for mounting onto a 3/8 to 1/2 in. (10 to 13 mm) square or round VAV box damper shaft. The minimum VAV box damper shaft length is 1-9/16 in. (40 mm).

The two mechanical end-limit set screws control the amount of rotation from 12° to 95°. These set screws must be securely fastened in place. To ensure tight closing of the damper, the shaft adapter has a total rotation stroke of 95° (see Fig. 1).

NOTE: The actuator is shipped with the mechanical end-limit set screws set to 95 degrees of rotation. Adjust the two set screws closer together to reduce the rotation travel. Each "hash mark" indicator on the bracket represents approximately 6.5° of rotation per side.

NOTE: The Declutch button, when pressed, allows you to rotate the universal shaft adapter (see Fig. 3).

IMPORTANT:

Determine the damper rotation and opening angle prior to installation. See Fig. 4 and 4 on page 5 for examples.

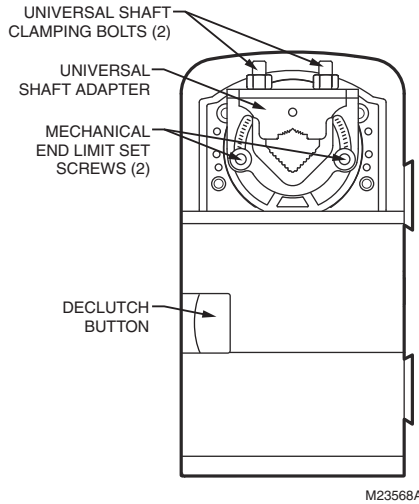

Fig. 3. Series 60 Floating Actuator

IMPORTANT: Mount actuator flush with damper housing or add a spacer between the actuator mounting surface and damper box housing.

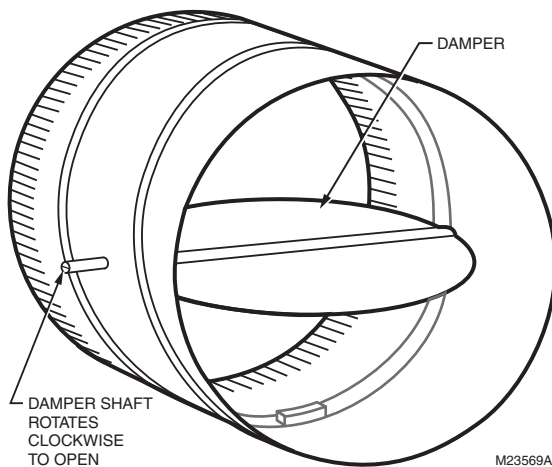

Fig. 4. Damper with 90 degree CW rotation to open.

Before Mounting Actuator onto Damper Shaft (CVL4022AS-VAV1 only)

Tools required:

- Phillips #2 screwdriver - end-limit set screw adjustment
- 8 mm wrench - centering clamp

Before mounting the actuator onto the VAV box damper shaft, determine the following:

1. Determine the damper shaft diameter. It must be between 3/8 in. to 1/2 in. (10 to 13 mm).
2. Determine the length of the damper shaft. If the length of the VAV box damper shaft is less than 1-9/16 in. (40 mm), the actuator cannot be used.

3. Determine the direction the damper shaft rotates to open the damper (CW or CCW) (see Fig. 4). Typically, there is an etched line on the end of the damper shaft that indicates the position of the damper. In Fig. 2, the indicator shows the damper open in a CW direction.
4. Determine the damper full opening angle (45, 60, or 90 degrees). In Fig. 4, the damper is open to its full open position of 90 degrees.

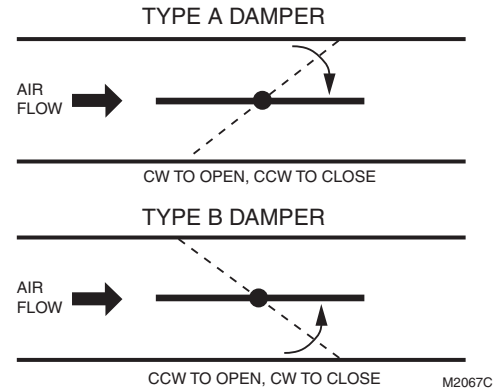

Fig. 5. Determining the rotation direction (CW or CCW) for damper opening.

Mounting Actuator onto Damper Shaft (CVL4022AS-VAV1 only)

The unit is shipped with the actuator set to rotate open in the clockwise (CW) direction to a full 95 degrees. The extra 5 degrees ensures a full opening range for a 90 degree damper. The installation procedure varies depending on the damper opening direction and angle:

1. If the damper rotates clockwise (CW) to open, and the angle of the damper open-to-closed is 90 degrees:
 - a. Manually open the damper fully (rotate clockwise).
 - b. Using the Declutch button, rotate the universal shaft adapter fully clockwise.
 - c. Mount the actuator to the VAV damper box and shaft.
 - d. Tighten the two bolts on the centering clamp (8 mm wrench; 70.8-88.5 lb-in. [8-10 Nm] torque). When the actuator closes, the damper rotates CCW 90 degrees to fully close.
2. If the damper rotates clockwise (CW) to open, and the angle of the damper open-to-closed is 45 or 60 degrees:
 - a. Manually open the damper fully (rotate clockwise).
 - b. The actuator is shipped with the mechanical end-limits set at 95 degrees. Adjust the two mechanical end-limit set screws to provide the desired amount of rotation. Adjust the two set screws closer together to reduce the rotation travel.
 - c. Tighten the two mechanical end-limit screws (Phillips #2 screwdriver; (26.5-31 lb-in. [3.0-3.5 Nm] torque).
 - d. Using the Declutch button, rotate the universal shaft adapter fully clockwise.
 - e. Mount the actuator to the VAV damper box and shaft.
 - f. Tighten the two bolts on the centering clamp (8 mm wrench; 70.8-88.5 lb-in. [8-10 Nm] torque).
 - g. When the actuator closes, the damper rotates CCW either 45 or 60 degrees to fully close.

3. If the damper rotates counterclockwise (CCW) to open, and the angle of the damper open-to-closed is 90 degrees:
 - a. Manually open the damper fully (rotate counterclockwise).
 - b. Using the Declutch button, rotate the universal shaft adapter fully counterclockwise.
 - c. Mount the actuator to the damper box and shaft.
 - d. Tighten the two bolts on the centering clamp (8 mm wrench; 70.8-88.5 lb-in. [8-10 Nm] torque). When the actuator closes, the damper rotates CW 90 degrees to fully close.
4. If the damper rotates counterclockwise (CCW) to open, and the angle of the damper open-to-closed is 45 or 60 degrees:
 - a. Manually open the damper fully (rotate counterclockwise).
 - b. The actuator is shipped with the mechanical end-limits set at 95 degrees. Adjust the two mechanical end-limit set screws to provide the desired amount of rotation. Adjust the two set screws closer together to reduce the rotation travel.
 - c. Tighten the two mechanical end-limit screws (Phillips #2 screwdriver; 26.5-31 lb-in. [3.0-3.5 Nm] torque).
 - d. Using the Declutch button, rotate the universal shaft adapter fully counter-clockwise.
 - e. Mount the actuator to the VAV damper box and shaft.
 - f. Tighten the two bolts on the centering clamp (8 mm wrench; 70.8-88.5 lb-in. [8-10 Nm] torque).
 - g. When the actuator closes, the damper rotates CW either 45 or 60 degrees to fully close.

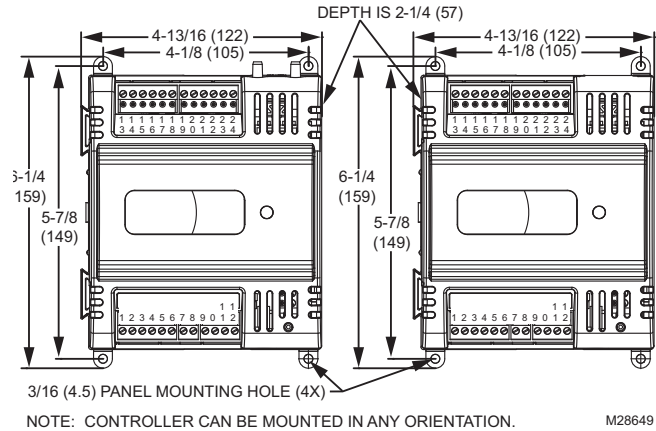

Fig. 6. Panel mounting - controller dimensions in inches (mm) for CVL4024NS-VAV1 only.

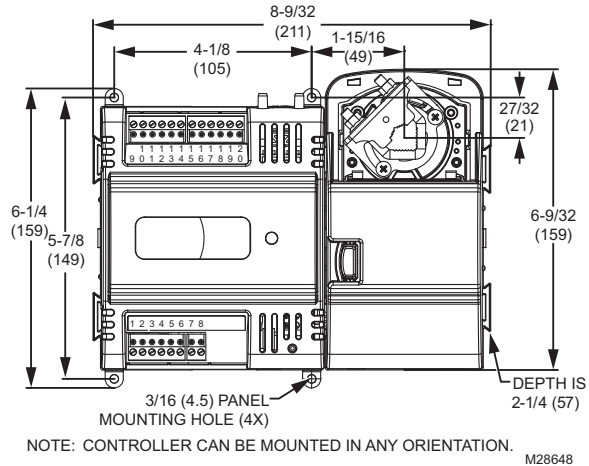

Fig. 7. Panel mounting - controller and actuator dimensions in inches (mm) for CVL4022AS-VAV1 only.

Mount Controller

NOTE: The controller may be wired before mounting to a panel or DIN rail. Terminal blocks are used to make all wiring connections to the controller. Attach all wiring to the appropriate terminal blocks (See “Wiring” on page 7). See Fig. 6 and 7 for panel mounting dimensions. See Fig. 8 on page 7 for DIN rail mounting.

Panel Mounting

NOTE: The controller enclosure is constructed of a plastic base plate and a plastic factory-snap-on cover.

The controller is designed so that the cover does not need to be removed from the base plate for either mounting or wiring. The controller mounts using four screws inserted through the corners of the base plate. Fasten securely with four No. 6 or No. 8 machine or sheet metal screws.

The controller can be mounted in any orientation. Ventilation openings are designed into the cover to allow proper heat dissipation, regardless of the mounting orientation.

DIN Rail Mounting (CUL6438SR-CV1 and CVL4024NS-VAV1)

To mount the CUL6438SR-CV1 or CVL4024NS-VAV1 controller on a DIN rail [standard EN50022; 1-3/8 in. x 9/32 in. (7.5 mm x 35 mm)], refer to Fig. 8 and perform the following steps:

1. Holding the controller with its top tilted in towards the DIN rail, hook the two top tabs on the back of the controller onto the top of the DIN rail.
2. Push down and in to snap the two bottom flex connectors of the controller onto the DIN rail.

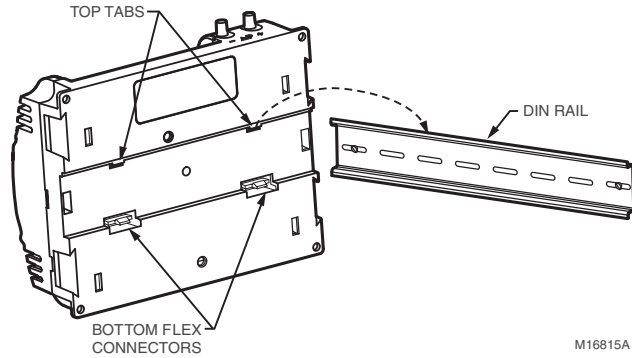

Fig. 8. Controller DIN rail mounting (CVL4024NS-VAV1 is shown here).

IMPORTANT NOTE:

To remove the controller from the DIN rail, perform the following:

1. Push straight up from the bottom to release the top tabs.
2. Rotate the top of the controller out towards you and pull the controller down and away from the DIN rail to release the bottom flex connectors.

Piping (CVL4022AS-VAV1 and CVL4024NS-VAV1 only)

Air flow Pickup

Connect the air flow pickup to the two restrictor ports on the controller (see Fig. 9).

NOTES:

- Use 1/4 inch (6 mm) outside diameter, with a 0.040 in. (1 mm) wall thickness, plenum-rated 1219 FR (94V-2) tubing.
- Always use a fresh cut on the end of the tubing that connects to the air flow pickups and the restrictor ports on the controller.

Connect the high pressure or upstream tube to the plastic restrictor port labeled (+), and the low pressure or downstream tube to the restrictor port labeled (-). See labeling in Fig. 9. When twin tubing is used from the pickup, split the pickup tubing a short length to accommodate the connections.

NOTES:

- If controllers are mounted in unusually dusty or dirty environments, an inline, 5-micron disposable air filter (use 5-micron filters compatible with pneumatic controls) is recommended for the high pressure line (marked as +) connected to the air flow pickup.
- The tubing from the air flow pickup to the controller should not exceed three feet (0.914 m). Any length greater than this will degrade the flow sensing accuracy.
- Use caution when removing tubing from a connector.

Always pull straight away from the connector or use diagonal cutters to cut the edge of the tubing attached to the connector. Never remove by pulling at an angle.

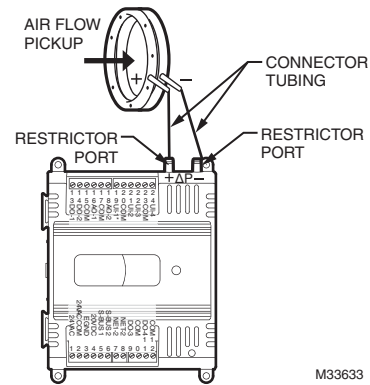

Fig. 9. Air flow pickup connections

Wiring

All wiring must comply with applicable electrical codes and ordinances, or as specified on installation wiring diagrams.

Controller wiring is terminated to the screw terminal blocks located on the top and the bottom of the device.

WARNING

**Electrical Shock Hazard.
Can cause severe injury, death or property damage.**

Disconnect power supply before beginning wiring or making wiring connections, to prevent electrical shock or equipment damage.

Power Wiring

GUIDELINES FOR POWER WIRING

For multiple controllers operating from a single transformer, the same side of the transformer secondary must be connected to the same power input terminal in each device. The earth ground terminal must be connected to a verified earth ground for each controller in the group (see Fig. 12 on page 9). Controller configurations are not necessarily limited to two devices, but the total power draw, including accessories, cannot exceed 100 VA when powered by the same transformer (U.S. only).

- See Fig. 11 on page 8 for controller power wiring used in UL 1995 equipment (U.S. only).
- Many controllers require all loads to be powered by the same transformer that powers the controller.
- Keep the earth ground connection wire run as short as possible (refer to Fig. 10-Fig. 12 beginning on page 8).
- Do not connect earth ground to the controller's digital or analog ground terminals (refer to Fig. 10 and Fig. 12).
- Do not connect the universal input COM terminals, analog output COM terminals or the digital input/output COM terminals to earth ground. Refer to Fig. 10-12 for wiring examples. The 24 Vac power from an energy limited Class II power source must be provided to the controller. To conform to Class II restrictions (U.S. only), the transformer must not be larger than 100 VA. Fig. 10 depicts a single controller using one transformer.

- Unswitched 24 Vac power wiring can be run in the same conduit as the LONWORKS® Bus cable.
- Maintain at least a 3 in. (76 mm) separation between Triac outputs and LONWORKS® Bus wiring throughout the installation.

IMPORTANT

Power must be off prior to connecting to or removing connections from the 24 Vac power (24 Vac/24 Vac COM), earth ground (EGND), and 20 Vdc power (20 Vdc) terminals.

IMPORTANT

Use the heaviest gauge wire available, up to 14 AWG (2.0 sq mm), with a minimum of 18 AWG (1.0 sq mm), for all power and earth ground wiring. Screw-type terminal blocks are designed to accept up to one 14 AWG (2.0 sq mm) conductor or up to two 18 AWG (1.0 sq mm) conductors. More than two wires that are 18 AWG (2.0 sq mm) can be connected with a wire nut. Include a pigtail with this wire group and attach the pigtail to the terminal block.

IMPORTANT

If the controller is used on **Heating and Cooling Equipment (UL 1995, U.S. only)** and the transformer primary power is more than 150 volts, connect terminal 2, (the 24 Vac common [24 VAC COM] terminal) to earth ground (see Fig. 11). For these applications, only one controller can be powered by each transformer.

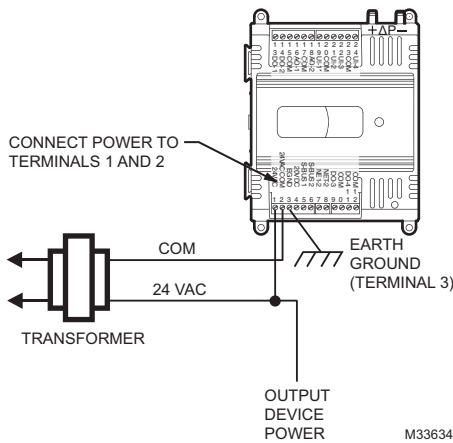

Fig. 10. Power wiring details for one controller per transformer

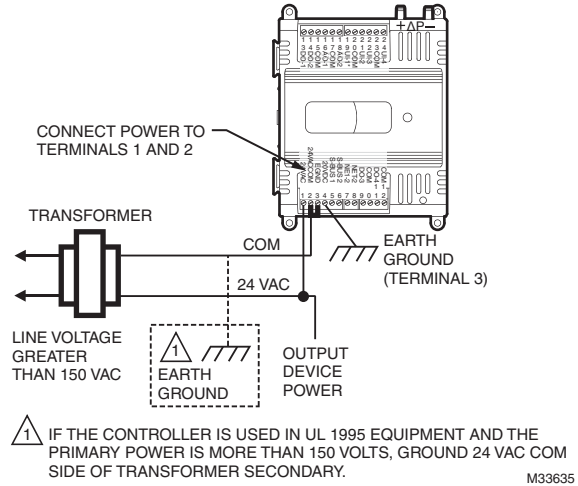

Fig. 11. Transformer power wiring details for one controller used in UL 1995 equipment (U.S. only).

NOTE: More than one controller can be powered by a single transformer. Fig. 12 shows power wiring details for multiple controllers. Controller configurations are not necessarily limited to three devices, but the total power draw, including accessories, cannot exceed 100 VA when powered by the same transformer (U.S. only). For power wiring recommendations, see "Power" below.

Power

Before wiring the controller, determine the input and output device requirements for each controller used in the system. Select input and output devices compatible with the controller and the application. Consider the operating range, wiring requirements, and the environment conditions when selecting input/output devices. When selecting actuators for modulating applications, consider using floating control. In direct digital control applications, floating actuators will generally provide control action equal to or better than an analog input actuator for lower cost.

Determine the location of controllers, sensors, actuators and other input/output devices and create wiring diagrams. Refer to Fig. 18 and 19 beginning on page 14 for illustrations of typical controller wiring for various configurations.

The application engineer must review the control job requirements. This includes the sequences of operation for the controller, and for the system as a whole. Usually, there are variables that must be passed between the controllers that are required for optimum system wide operation. Typical examples are the TOD, Occ/Unocc signal, the outdoor air temperature, the demand limit control signal, and the smoke control mode signal.

It is important to understand these interrelationships early in the job engineering process, to ensure proper implementation when configuring the controllers.

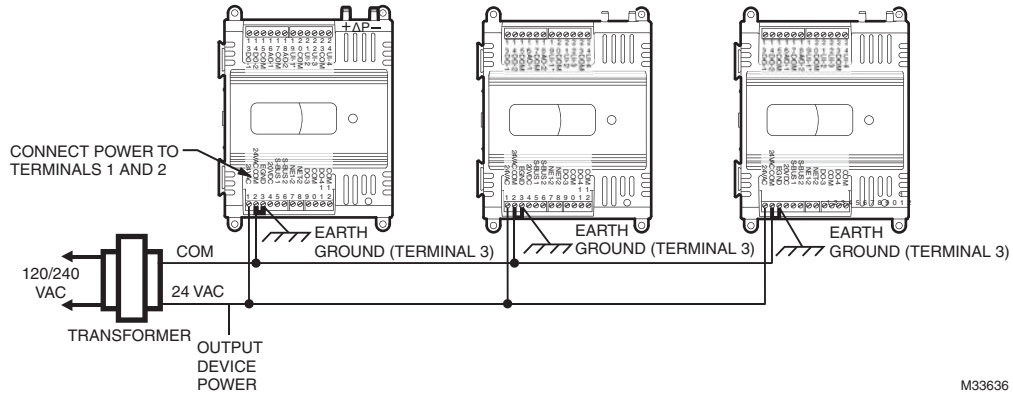

Fig. 12. Power wiring details for two or more controllers per transformer

Power Budget

A power budget must be calculated for each device to determine the required transformer size for proper operation. A power budget is simply the summing of the maximum power draw ratings (in VA) of all the devices to be controlled. This includes the controller itself and any devices powered from the controller, such as equipment actuators (ML6161 or other motors) and various contactors and transducers.

IMPORTANT

- If a controller is used on Heating and Cooling Equipment (UL 1995, U.S. only) and transformer primary power is more than 150 volts, connect the transformer secondary common to earth ground (see Fig. 11 on page 8).
- When multiple controllers operate from a single transformer, connect the same side of the transformer secondary to the same power input terminal in each device. The earth ground terminal (terminal 3) must be connected to a verified earth ground for each controller in the group (see Fig. 12).

POWER BUDGET CALCULATION EXAMPLE

Table 4 is an example of a power budget calculation for a typical CVL controller.

The system example above requires 30.7 VA of peak power. Therefore, a 100 VA AT92A transformer could be used to power one controller of this type. Because the total peak power is less than 50 VA, this same transformer could be on page 11 for illustrations of controller power wiring. See Table 6 for VA ratings of various devices.

For contactors and similar devices, the in-rush power ratings should be used as the worst case values when performing power budget calculations. Also, the application engineer must consider the possible combinations of simultaneously energized outputs and calculate the VA ratings accordingly. The worst case, which uses the largest possible VA load, should be determined when sizing the transformer. Each controller requires 24 Vac power from an energy-limited Class II power source. To conform to Class II restrictions (U.S. only), transformers must not be larger than 100 VA. A single transformer can power more than one controller.

Table 4. Power budget calculation example

Device	VA Information	Obtained From
CVL4022AS-VAV1 controller (include Series 60 Floating Damper Actuator)	9.0	See “Specifications” on page 2.
R8242A Contactor fan rating	21.0	TRADELINE® Catalog inrush rating
D/X Stages	0.0	For example, assume cooling stage outputs are wired into a compressor control circuit and have no impact on the budget.
M6410A Steam Heating Coil Valve	0.7	TRADELINE® Catalog, 0.32A 24 Vac
TOTAL	30.7	

Table 5. VA ratings for transformer sizing.

Device	Description	VA
CVL4022AS-VAV1 controllers and Series 60 Floating Damper Actuator	Controller and Actuator	9.0
CVL4024NS-VAV1	Controller	5.0
ML684	Versadrive Valve Actuator	12.0
ML6161	Damper Actuator, 35 lb-in.	2.2
ML6185	Damper Actuator SR 50 lb-in	12.0
ML6464	Damper Actuator, 66 lb-in.	3.0
ML6474	Damper Actuator, 132 lb-in.	3.0
R6410A	Valve Actuator	0.7
R8242A	Contactors	21.0

Line-Loss

Controllers must receive a minimum supply voltage of 20 Vac. If long power or output wire runs are required, a voltage drop due to Ohms Law ($I \times R$) line-loss must be considered. This line-loss can result in a significant increase in total power required and thereby affect transformer sizing. The following

example is an I x R line-loss calculation for a 200 ft. (61m) run from the transformer to a controller drawing 37 VA and using two 18 AWG (1.0 sq mm) wires.

The formula is:

$$\text{Loss} = [\text{length of round-trip wire run (ft.)}] \times [\text{resistance in wire (ohms per ft.)}] \times [\text{current in wire (amperes)}]$$

From specification data:

18 AWG twisted pair wire has a resistance of 6.52 ohms per 1000 feet.

$$\text{Loss} = [(400 \text{ ft.}) \times (6.52/1000 \text{ ohms per ft.})] \times [(37 \text{ VA})/(24\text{V})] = 4.02 \text{ volts}$$

This means that four volts are going to be lost between the transformer and the controller. To assure the controller receives at least 20 volts, the transformer must output more than 24 volts. Because all transformer output voltage levels depend on the size of the connected load, a larger transformer outputs a higher voltage than a smaller one for a given load.

Fig. 13 shows this voltage load dependence.

In the preceding I x R loss example, even though the controller load is only 37 VA, a standard 40 VA transformer is not sufficient due to the line-loss. Looking at Fig. 13 a 40 VA transformer is just under 100 percent loaded (for the 37 VA controller) and has a secondary voltage of 22.9 volts. (Use the lower edge of the shaded zone in Fig. 13 that represents the worst case conditions.) When the I x R loss of four volts is subtracted, only 18.9 volts reaches the controller. This is not enough voltage for proper operation. In this situation, the engineer has three alternatives:

1. Use a larger transformer. For example, if an 80 VA model is used, an output of 24.4 volts, minus the four volt line-loss, supplies 20.4V to the controller (see Fig. 13).

Although acceptable, the four-volt line-loss in this example is higher than recommended.

IMPORTANT

No installation should be designed where the line-loss is greater than two volts. This allows for nominal operation if the primary voltage drops to 102 Vac (120 Vac minus 15 percent).

2. Use heavier gauge wire for the power run. 14 AWG (2.0 sq mm) wire has a resistance of 2.57 ohms per 1,000 ft. Using the preceding formula results in a line-loss of only 1.58 volts (compared with 4.02 volts). This would allow a 40 VA transformer to be used. 14 AWG (2.0 sq mm) wire is the recommended wire size for 24 Vac wiring.
3. Locate the transformer closer to the controller. This reduces the length of the wire run, and the line-loss. The issue of line-loss is also important in the case of the output wiring connected to the Triac digital outputs. The same formula and method are used. Keep all power and output wire runs as short as practical. When necessary, use heavier gauge wire, a bigger transformer, or install the transformer closer to the controller.

To meet the National Electrical Manufacturers Association (NEMA) standards, a transformer must stay within the NEMA limits. The chart in Fig. 13 shows the required limits at various

loads. With 100 percent load, the transformer secondary must supply between 23 and 25 volts to meet the NEMA standard. When a purchased transformer meets the NEMA standard DC20-1986, the transformer voltage regulating ability can be considered reliable. Compliance with the NEMA standard is voluntary.

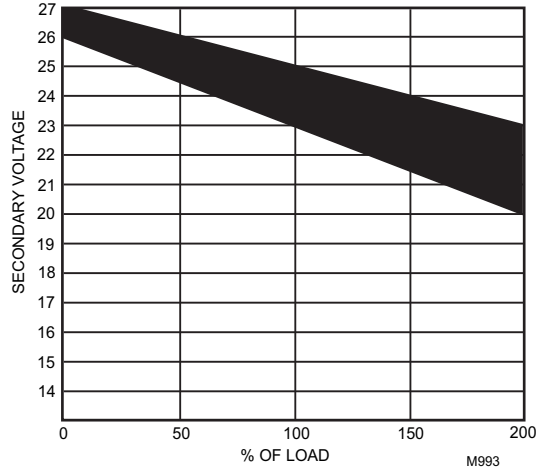

Fig. 13. NEMA Class 2 transformer voltage output limits

The Honeywell transformers listed in Table 5 meet the NEMA standard DC20-1986.

Table 6. Honeywell transformers that meet NEMA standard DC20-1986

Transformer Type	VA Rating
AT40A	40
AT72D	40
AT87A	50
AK3310 Assembly	100

NOTE: The AT88A and AT92A transformers do not meet the voluntary NEMA standard DC20-1986.

Bus Communication Wiring

The maximum LONWORKS® Bus network length is 4,600 ft. (1,400 m). For LONWORKS® Bus network lengths greater than the above, see "LONWORKS® Bus Wiring Guidelines," form no. 74-2865. The theoretical limit for each LONWORKS® Bus segment is 60 controllers. Up to 120 controllers can be configured when the Q7751A,B Router (configured as a repeater) is used, and the bus must be either singly or doubly terminated. Each network segment can have a maximum of one repeater. Actual installations may have a lower limit, depending on the devices connected.

Honeywell provided cable types for LONWORKS® Bus communications wiring are Level IV 22 AWG (0.34 sq mm) plenum or non-plenum rated unshielded, twisted pair, stranded conductor wire.

- For non-plenum areas, U.S. part AK3798 (single-pair stranded) can be used.
- In plenum areas, U.S. part AK3797 (single-pair stranded) or U.S. part AK3799 (two-pair stranded) can be used.

Contact Echelon Corp. Technical Support for the recommended vendors of Echelon approved cables.

Communications wiring can be run in a conduit, if needed, with non-switched 24 Vac or sensor wiring.

Pull the cable to each controller on the LONWORKS® Bus and connect to the controller's communication terminals 7 and 8. (See Table 7 on page 12 and Table 8 on page 13, and Fig. 16 on page 13 for location of terminals 7 and 8.)

NOTE: Connection for operator access to the LONWORKS® Bus is provided by plugging the Serial LONTALK® Adapter (SLTA) connector into the LONWORKS® Bus jack (see Fig. 16 and Fig. 17 on page 13).

IMPORTANT

Notes on communications wiring:

- All field wiring must conform to local codes and ordinances (or as specified on installation drawings).
- Do not bundle device output wires with sensor, digital input or communications LONWORKS® Bus wires.
- Do not use different wire types or gauges on the same LONWORKS Bus segment. The step change in line impedance characteristics causes unpredictable reflections on the LONWORKS® Bus.
- In noisy (high EMI) environments, avoid wire runs parallel to noisy power cables, motor control centers, or lines containing lighting dimmer switches. Keep at least 3 in. (76 mm) of separation between noisy lines and the LONWORKS® Bus cable.

The theoretical limit for each LONWORKS® Bus segment is 60 controllers. Up to 120 controllers can be configured when a repeater is used, and the bus must be either singly or doubly terminated. Actual installations may have a lower limit depending on the devices connected.

- The singly terminated bus must have one 209541B Excel 10 FTT Termination Module for T tap or Star configurations.
- The doubly terminated bus must have two 209541B Excel 10 FTT Termination Modules, one at each end of the daisy chain (Bus style) wiring run. Note that the Q7751A,B router (configured as a repeater) has onboard terminating networks that can be jumper selected on each segment.
- Make sure that neither of the LONWORKS® Bus wires are grounded.

NOTE: If a 209541B Termination Module is required at the controller, connect two of the three termination module wires to the LONWORKS® Bus terminals 7 and 8, which are labeled Net-1 and Net-2, on the controller. Selecting the appropriate two wires depends on the LONWORKS® Bus network topology. Refer to the "LONWORKS® Bus Wiring Guidelines," form 74-2865, and the "Excel 10 FTT Termination Module Installation Instructions," form 95-7554. For example, on a doubly terminated daisy-chained bus topology, where controllers are on either end of an LONWORKS® Bus wire run, mount the termination module on the appropriate terminals, as shown in Fig. 14.

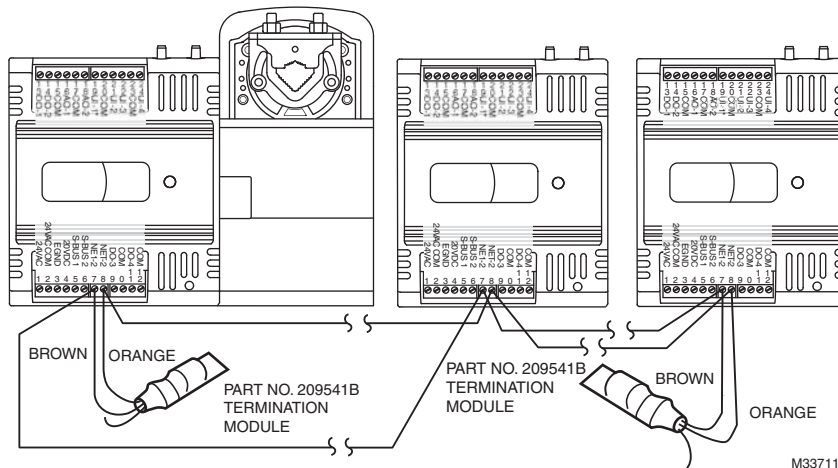

Fig. 14. Termination Modules (LONWORKS® daisy chain connections)

Wiring Method

NOTE: When attaching two or more wires to the same terminal, other than 14 AWG (2.0 sq mm), be sure to twist them together. Deviation from this rule can result in improper electrical contact (see Fig. 15). Each terminal can accommodate the following gauges of wire:

- Single wire: from 22 AWG to 14 AWG solid or stranded
- Multiple wires: up to two 18 AWG stranded, with 1/4 watt wire-wound resistor

Prepare wiring for the terminal blocks, as follows:

1. Strip 1/2 in. (13 mm) insulation from the conductor.
2. Cut a single wire to 3/16 in. (5 mm). Insert the wire in the required terminal location and tighten the screw.
3. If two or more wires are being inserted into one terminal location, twist the wires together a minimum of three turns before inserting them (see Fig. 15).
4. Cut the twisted end of the wires to 3/16 in. (5 mm) before inserting them into the terminal and tightening the screw.
5. Pull on each wire in all terminals to check for good mechanical connection.

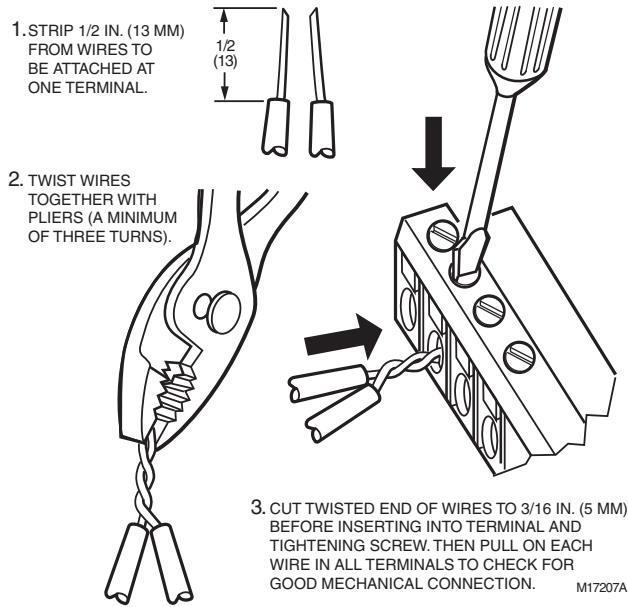

Fig. 15. Attaching two or more wires at terminal blocks.

Wiring Details

Each controller is shipped with the digital outputs, which switch the 24 Vac to the load (High Side). The three analog outputs (AO) are used to control modulating heating, cooling and economizer equipment. Any AO may be used as a digital output, as follows:

- False (0%) produces 0 Vdc, (0 mA)
- True (100%) produces the maximum 11 Vdc (22 mA)

The wiring connection terminals described in Table 7 and 8 are shown in Fig. 18-22 starting on page 14.

IMPORTANT

If the controller is not connected to a good earth ground, the controller's internal transient protection circuitry is compromised and the function of protecting the controller from noise and power line spikes cannot be fulfilled. This could result in a damaged circuit board and require replacement of the controller.

NEURON® SERVICE PIN

The NEURON® Service Pin pushbutton (when pressed) transmits the Service Message to the network, regardless of the controller's current mode of operation (see Fig. 16 and 17 on page 13).

Table 7. Description of CVL4022AS-VAV1 and CVL4024NS-VAV1 wiring terminal connections.

Terminal	Label	Connection
INPUT POWER & GROUND		
1	24 Vac	24 Vac Power
2	24 Vac COM	24 Vac Power
3	EGND	Earth Ground
4	20Vdc	20 Vdc Power
5	SBUS 1	Sylk
6	SBUS 2	Sylk
NETWORK CONNECTIONS		
7	NET-1	LONWORKS® communications
8	NET-2	LONWORKS® communications
DIGITAL OUTPUTS ^a		
9	DO-3	Digital Output
10	COM	Digital Output
11	DO-4	Digital Output
12	COM	Common
13	DO-1	Digital Output
14	DO-2	Digital Output
15	COM	Common
ANALOG OUTPUTS ^b		
16	AO-1	Analog Output
17	COM	Common
18	AO-2	Analog Output
UNIVERSAL INPUTS		
19	UI-1	Universal Input
20	COM	Common
21	UI-2	Universal Input
22	UI-3	Universal Input
23	COM	Common
24	UI-4	Universal Input

^a For the CVL4022AS controller ONLY, terminals 9-12 (DO3, DO4, & COM) are not present. The actuator is internally hardwired to these terminals.

^b Analog outputs may be configured as digital outputs and operate as follows:
 – False (0%) produces 0 Vdc, (0 mA)
 – True (100%) produces the maximum 11 Vdc (22 mA)

⚠ CAUTION

Equipment Damage Hazard.
 Can cause controller damage or failure.

Do not use any metal object to press the NEURON® Service Pin. Use a plastic rod or wood device (such as a pencil with the lead broken off) to press the pin. Using a metal object can damage the circuitry of the controller.

LONWORKS BUS CONVENIENCE JACK

The LONWORKS Bus connection is provided by plugging the Serial LONTALK Adapter (SLTA) connector into the LONWORKS® Bus Jack (see Fig. 16 and Fig. 17 on page 13).

Table 8. Description of CUL6438SR-CV1 wiring terminal connections.

Terminal	Label	Connection
INPUT POWER & GROUND		
1	24 Vac	24 Vac Power
2	24 Vac COM	24 Vac Power
3	EGND	Earth Ground
4	SHLD	Shield
5	SBUS 1	Sylk
6	SBUS 2	Sylk
NETWORK CONNECTIONS		
7	NET-1	LONWORKS® communications
8	NET-2	LONWORKS® communications
DIGITAL OUTPUTS		
9	24 Vac Out	24 Vac Power
10	COM-A	Common
11	COM-B	Common
12	COM-C	Common
13	DO-C1	Digital Output
14	DO-A1	Digital Output
15	DO-A2	Digital Output
16	DO-A3	Digital Output
17	DO-B1	Digital Output
18	DO-B2	Digital Output
19	DO-B3	Digital Output
20	DO-B4	Digital Output
ANALOG OUTPUTS^a		
21	AO-1	Analog Output
22	COM	Common
23	AO-2	Analog Output
24	AO-3	Analog Output
25	COM	Common
DIGITAL INPUTS^b		
26	DI-1	Digital Input
27	DI-2	Digital Input
28	COM	Common
29	DI-3	Digital Input
30	DI-4	Digital Input
ATTACHED DEVICE(S) POWER		
31	20 Vdc	20 Vdc Power
UNIVERSAL INPUTS		
32	UI-1	Universal Input
33	COM	Common
34	UI-2	Universal Input
35	UI-3	Universal Input
36	COM	Common
37	UI-4	Universal Input
38	UI-5	Universal Input
39	COM	Common
40	UI-6	Universal Input

^a Analog outputs may be configured as digital outputs and operate as follows:
 – False (0%) produces 0 Vdc, (0 mA)
 – True (100%) produces the maximum 11 Vdc (22 mA)

^b Digital inputs: Open circuit = False; Closed circuit = True

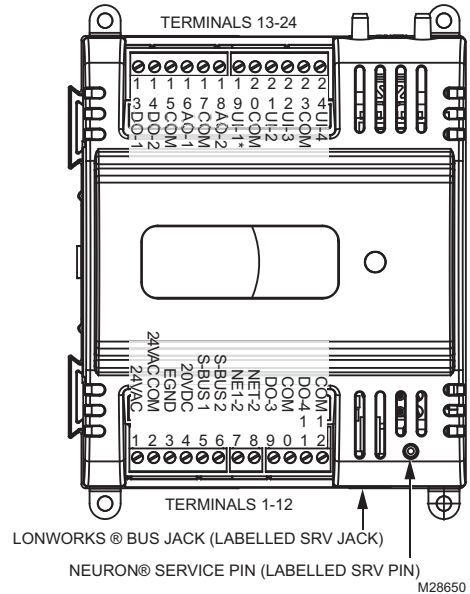

Fig. 16. Controller terminal connections, NEURON® Service Pin and LONWORKS® Bus Jack for the CVL4022AS-VAV1, and CVL4024NS-VAV1 (CVL4024NS-VAV1 shown).

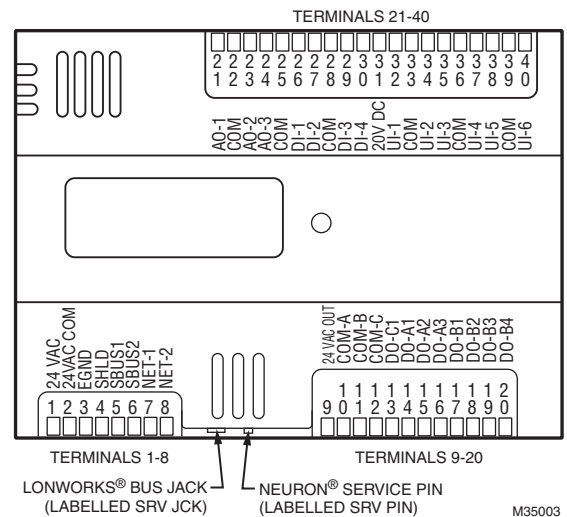

Fig. 17. Controller terminal connections, NEURON® service pin and LONWORKS® bus jack for CUL6438SR-CV1.

Wiring Applications (Examples)

Typical controller wiring for VAV applications (see Fig. 18 and Fig. 19 beginning page 14).

Typical controller wiring for CVAHU applications (see Fig. 20-22 beginning page 16).

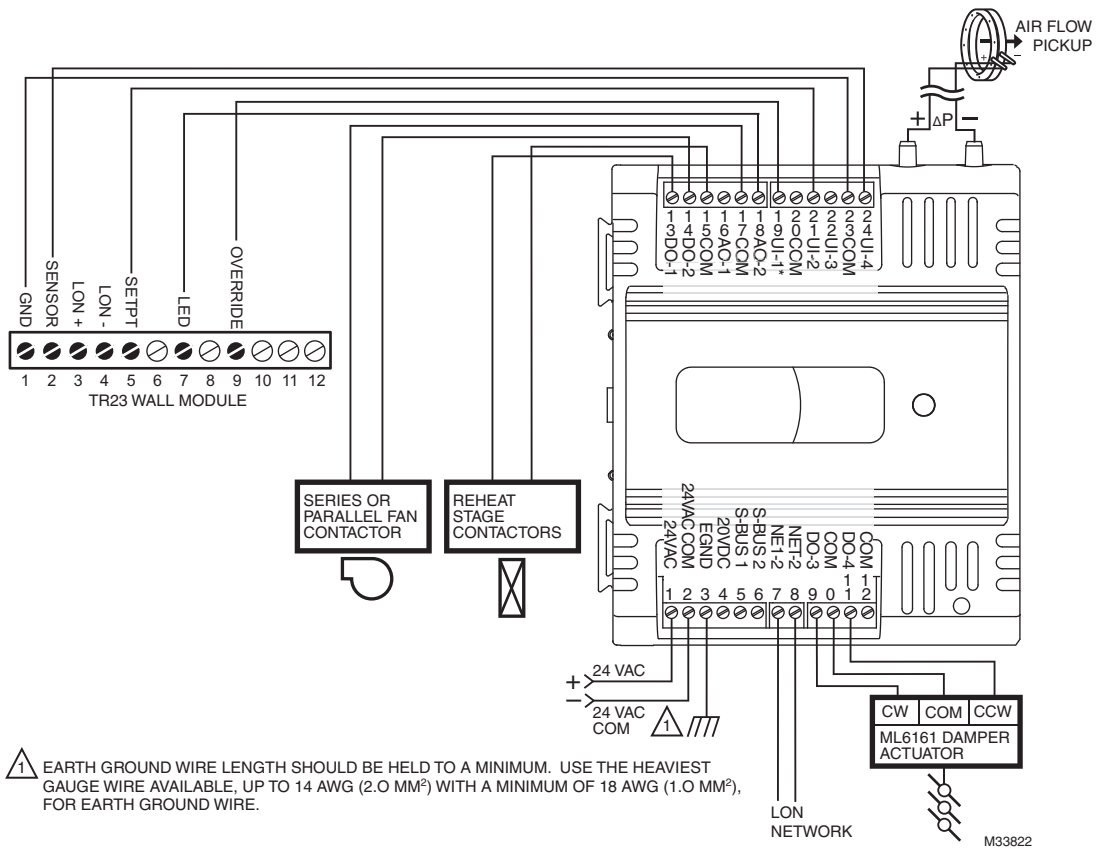

Fig. 18. Controller wiring diagram for typical VAV application, using the TR23 wall module.

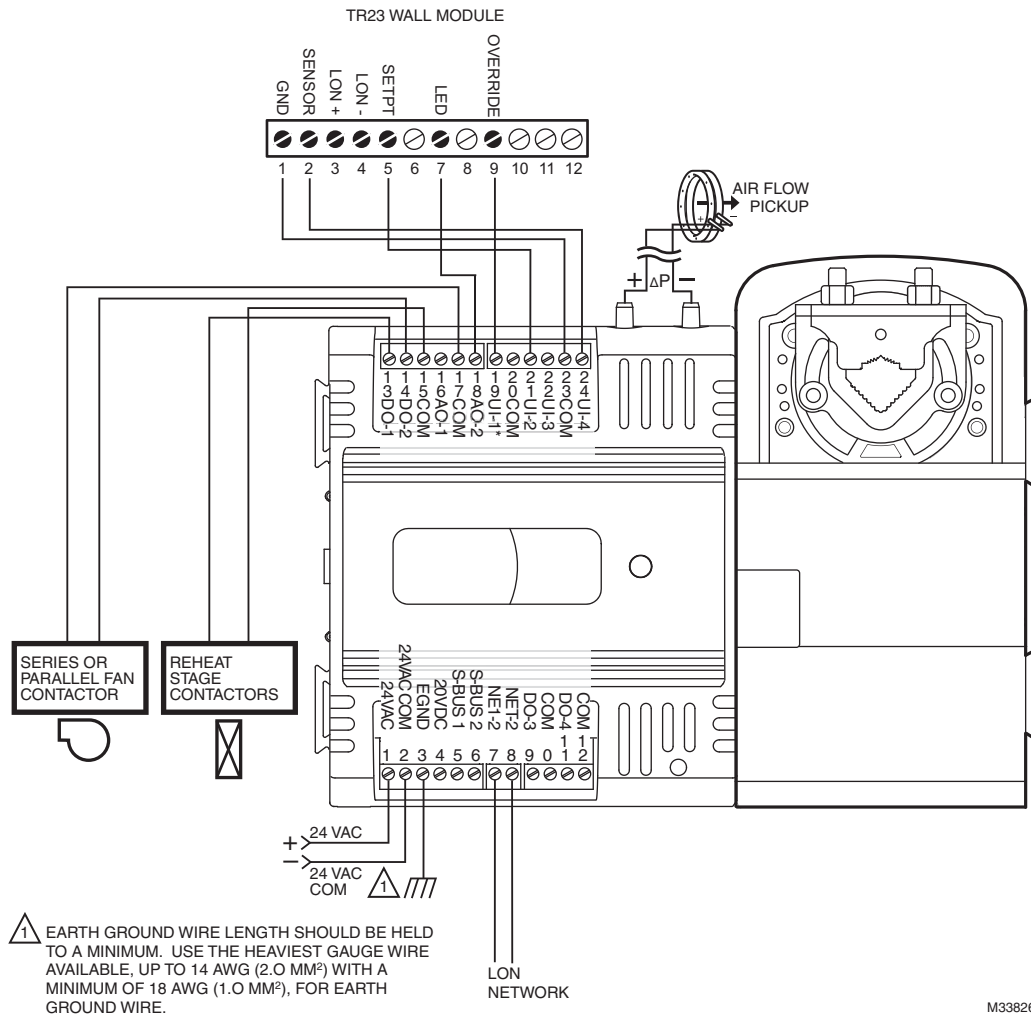

Fig. 19. Controller wiring diagram for typical VAV application with staged reheat.

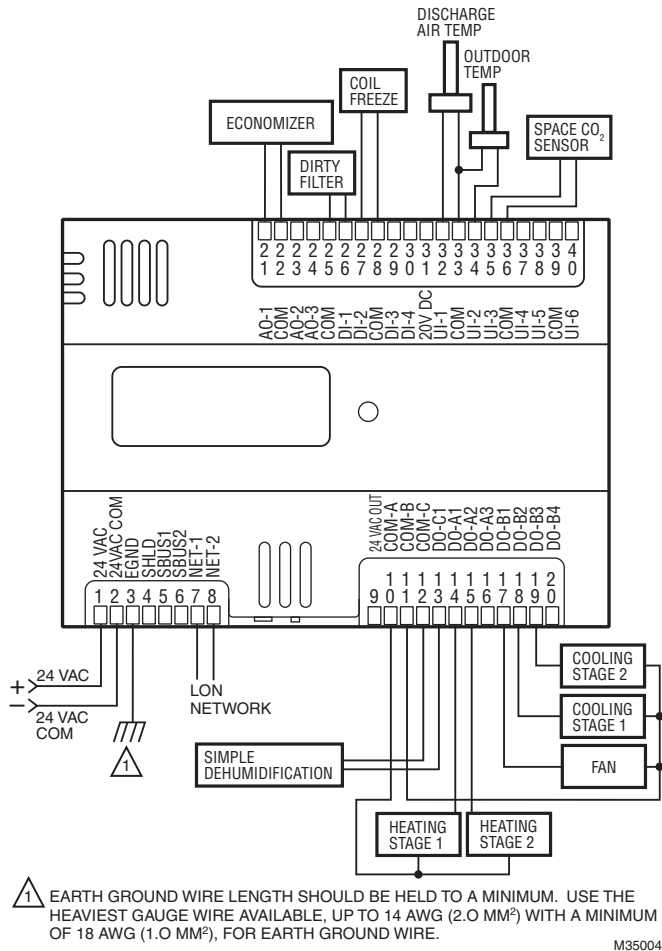

Fig. 20. Controller wiring diagram for a typical 2H/2C conventional system with a modulating economizer and dehumidification.

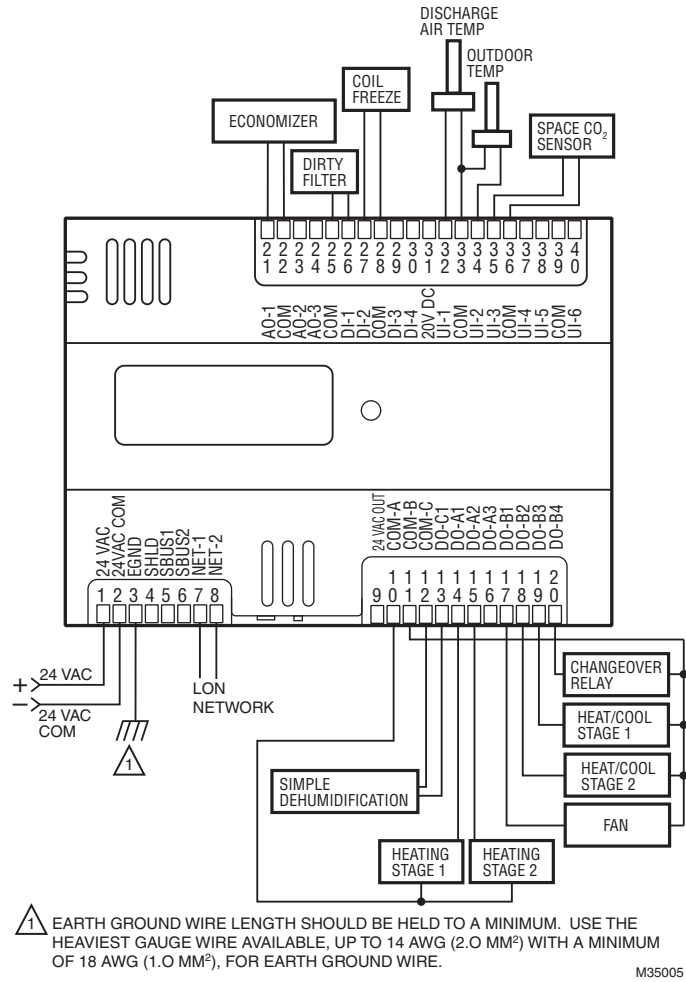

Fig. 21. Controller wiring diagram for a typical 2H/2C heat pump system with auxiliary heat, modulating economizer and dehumidification.

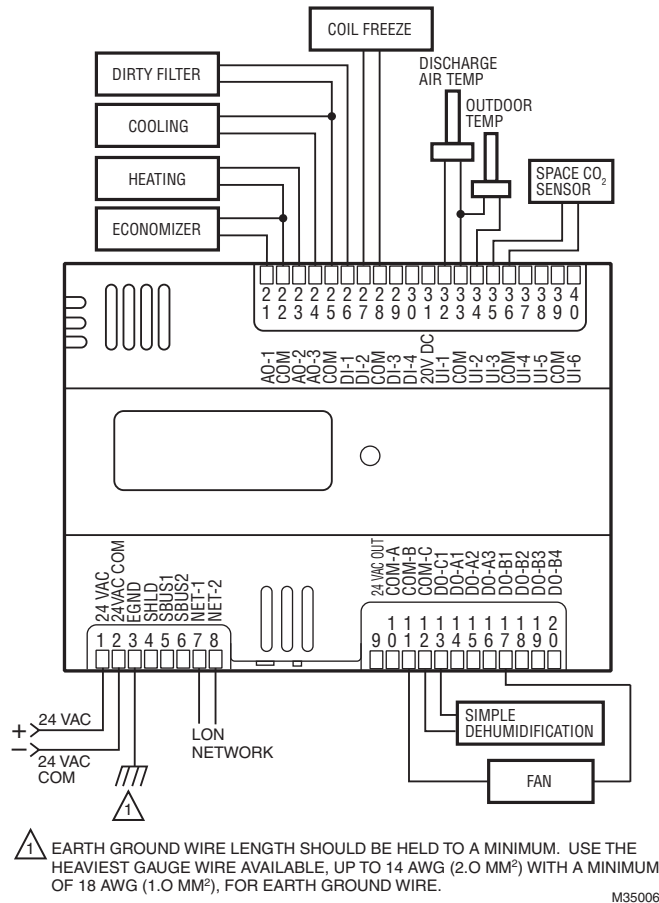

Fig. 22. Controller wiring diagram for a typical modulating heat/cool system with modulating economizer and dehumidification.

CHECKOUT

Step 1. Check Installation and Wiring

Inspect all wiring connections at the controller terminals, and verify compliance with installation wiring diagrams. If any wiring changes are required, first be sure to remove power from the controller before starting work. Pay particular attention to:

- 24 Vac power connections. Verify that multiple controllers being powered by the same transformer are wired with the transformer secondary connected to the same input terminal numbers on each controller. Use a meter to measure 24 Vac at the appropriate terminals (see Fig. 10 on page 8). Controller configurations are not necessarily limited to three devices, but the total power draw, including accessories, cannot exceed 100 VA when powered by the same transformer (U.S. only).
- Be sure that each controller has terminal 3 wired to a verified earth ground, using a wire run as short as possible with the heaviest gauge wire available, up to 14 AWG (2.0 sq mm) with a minimum of 18 AWG (1.0 sq mm) for each controller in the group (see Fig. 12 on page 9).
- Verify that Triac wiring of the digital outputs to external devices uses the proper load power and 24 Vac common terminal (digital output common terminals) for High-Side switching.

NOTE: All wiring must comply with applicable electrical codes and ordinances or as specified on installation wiring diagrams. For wiring run length and power budget guidelines, see "Power" on page 8".

VERIFY TERMINATION MODULE PLACEMENT (MULTIPLECONTROLLERS ONLY)

The installation wiring diagrams should indicate the locations for placement of the 209541B termination module(s). See Fig. 14 on page 11 and refer to the "LONWORKS® Bus Wiring Guidelines," form 74-2865. Correct placement of the termination module(s) is required for proper LONWORKS® Bus communications.

Step 2. Startup

Refer to Fig. 23 and the following text for startup information.

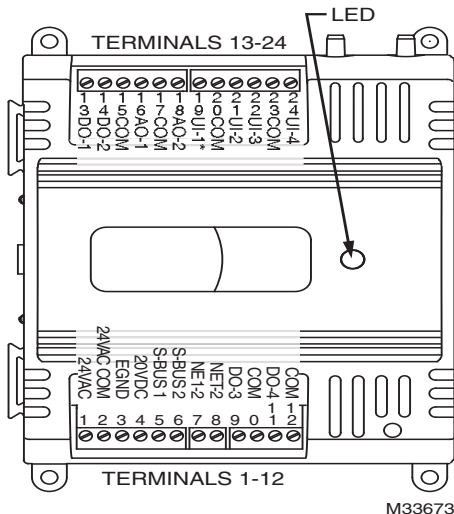

Fig. 23. LED location.

BROADCAST THE SERVICE MESSAGE

The Service Message allows a device on the LONWORKS® Bus to be positively identified. The Service Message contains the controller's Neuron® ID number and node type. This is used to confirm the physical location of a particular Stryket device in a building.

- To send the Service Message from the controller, press the NEURON® Service Pin pushbutton on the controller (see Fig. 23 and Fig. 16 and 17 on page 13). This button sends out the Service Message when it is pressed, regardless of the controller's current mode of operation

CAUTION

Equipment Damage Hazard.

Can cause controller damage or failure.

Do not use any metal object to press the NEURON® Service Pin. Use a plastic rod or wood device (such as a pencil with the lead broken off) to press the pin. Using a metal object can damage the circuitry of the controller.

CONTROLLER STATUS LED:

The LED on the front of the controller provides a visual indication of the status of the device. When the controller receives power, the LED appears in one of the following allowable states, as described in Table 9.

Table 9. Status LED States

LED State	Blink Rate	Status or Condition
OFF	not applicable	No power to processor, LED damaged, low voltage to board, or controller damaged.
ON	ON steady; not blinking	Processor and/or controller is not operating.
Very slow blink (continuous)	1 second ON, 1 second OFF	Controller is operating normally.
Slow blink (continuous)	0.5 second ON, 0.5 second OFF	Controller alarm is active, controller in process of download, or controller lost its configuration.
Medium blink (continuous)	0.25 second ON, 0.25 second OFF	Controller firmware is loading.
Fast blink (continuous)	0.10 second ON, 0.10 second OFF	Controller is in manual mode under control of the PC-based software tool.

Step 3. Checkout Completion

At this point the controller is installed and powered. To complete the checkout, the NIAGARA FRAMEWORK® application (run on a PC) is used to configure the I/O and functions of the controller. Refer to the Programming Tool User Guide, form no. 63-2662, for controller configuration and programming details.

⚠ WARNING

Fire, Explosion, or Electrical Shock Hazard. Can cause severe injury, death or property damage.

Do not attempt to modify the physical or electrical characteristics of this device in any way. Replace the controller if troubleshooting indicates a malfunction.

⚠ WARNING

Electrical Shock Hazard. Can cause severe injury, death or property damage.

Disconnect power supply before beginning controller replacement to prevent electrical shock or equipment damage.

Terminal Block Removal

To simplify controller replacement, all terminal blocks are designed to be removed with the wiring connections intact and then re-installed on the new controller. See Fig. 24 and refer to the following procedure.

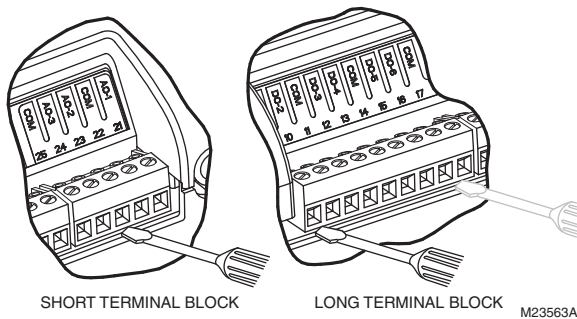

Fig. 24. Removing terminal blocks

IMPORTANT

To prevent bending or breaking the alignment pins on longer terminal blocks, insert the screwdriver at several points to evenly and gradually lift up the terminal block. Insert the screwdriver blade no more than 1/8 in. (3 mm) to prevent damage to the terminal block alignment pins on the controller circuit board.

1. Use a thin-bladed screwdriver to evenly raise the terminal block from its alignment pins:
 - a. For short terminal blocks (1 to 5 terminals), insert screwdriver blade in the center of the terminal block and use a back and forth twisting motion to gently raise the terminal block from its alignment pins 1/4 in. (6.35 mm).
 - b. For long terminal blocks (6 or more terminals), insert screwdriver blade on one side of the terminal block and gently rotate the blade 1/4 turn. Then, move to the other side of the terminal block and do the same. Repeat until the terminal block is evenly raised 1/4 in. (6.35 mm) from its alignment pins.
2. Once the terminal block is raised 1/4 in. (6.35 mm) from its alignment pins, grasp the terminal block at its center (for long terminal blocks grasp it at each end) and pull it straight up.

Controller Replacement

Perform the following to replace the controller:

1. Remove all power from the controller.
2. Remove the terminal blocks (See Fig. 24).
3. Remove the old controller from its mounting.

IMPORTANT

(FOR CONTROLLERS MOUNTED TO A DIN RAIL):

1. Push straight up from the bottom to release the top pins.
2. Rotate the top of the controller outwards to release the bottom flex connectors.
3. Mount the new controller (See "Mount Controller" on page 6).
4. Replace the terminal blocks:
 - a. Insert each terminal block onto its alignment pins.
 - b. Press straight down to firmly seat it.
 - c. Repeat for each terminal block.
5. Restore power to the controller.
6. Perform "Checkout."

By using this Honeywell literature, you agree that Honeywell will have no liability for any damages arising out of your use or modification to, the literature. You will defend and indemnify Honeywell, its affiliates and subsidiaries, from and against any liability, cost, or damages, including attorneys' fees, arising out of, or resulting from, any modification to the literature by you.

Automation and Control Solutions

Honeywell International Inc.
1985 Douglas Drive North
Golden Valley, MN 55422
customer.honeywell.com

© U.S. Registered Trademark
© 2013 Honeywell International Inc.
62-2029—02 KK Rev. 09-13
Printed in United States

Honeywell