

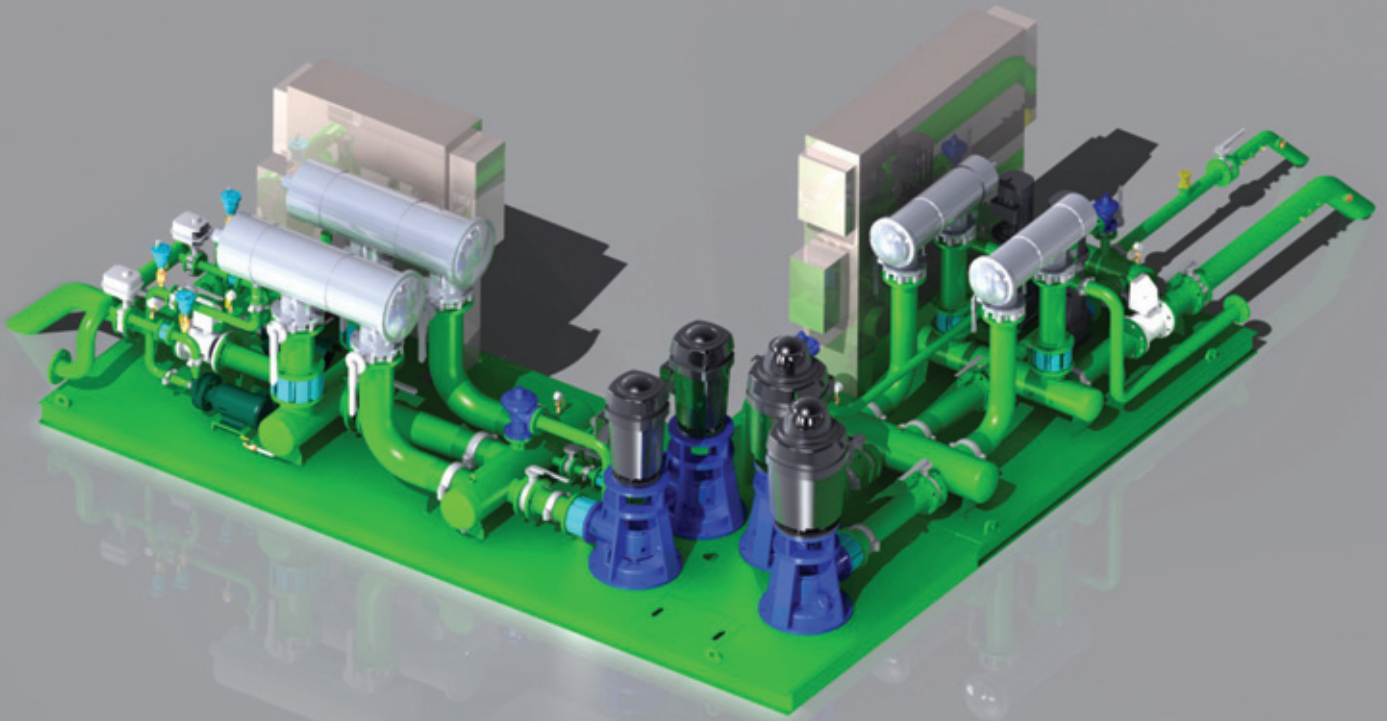

# Pump Station User Manual

## With E1071 Touch Screen



Revision 11.5.1 January 2010

## **To the Customer**

We recommend that the Customer study these instructions thoroughly and assure that it is available to those who install, maintain, or operate the Pump Station.

*These instructions will be of no use if they are unavailable when the operators need them!*

It is also important that You:

- Store and keep this manual and all other related documents with the Pump Station while it is in use.
- Add or replace any documents added or updated by Rain Bird.
- This text describes authorized methods to use the equipment.
- Rain Bird does not take responsibility for any damage to persons or equipment if the Pump Station is not operated, installed, or maintained according to the directions in the manual.
- The Manual is divided into the following sections:
  - Custom Features
  - User Manual
  - Pump Curve
  - Approval Drawing
  - Electrical Schematic
  - Optional Items
  - Installation Guidance and Instructions

Manufacturer: Rain Bird Corporation

Contact: Gordon Van Dyke  
Pump Station Product Manager  
6991 E. Southpoint Rd., Bldg. #1  
Tucson, AZ 85706 USA  
(520) 806-5654 (Phone)  
(520) 806-5678 (Fax)  
gvandyke@rainbird.com

### ***Safety Message***

Please take note of the following important definitions for messages included throughout the user manual.

**WARNING:** An operating or maintenance procedure, practice, condition, statement, which if not strictly observed could result in injury to or death of personnel or long term health hazards.

**CAUTION:** An operating or maintenance procedure, practice, condition, statement, which if not strictly observed could result in damage to or destruction of equipment.

**NOTE:** An operating procedure, condition or statement, which is essential to highlight.



## Contents

Rain Bird's Pump Station Professional Customer Satisfaction Policy.....	5
1.0 Identify Mechanical Components and Functions.....	6
2.0 Identify Electrical Components and Functions.....	11
Touch Screen Architecture.....	12
3.0 Touch Screen Introduction E1071.....	14
3.1 Login Codes.....	14
3.2 Basic Navigation.....	14
3.3 Pump Status Buttons.....	14
3.4 Parameter Definition and Adjustments E1071.....	15
4.0 Normal Pump Station Operations.....	17
4.1 Alarm Reset Procedures E1071.....	18
4.2 Manual VFD Operations E1071.....	19
4.3 Start-Up Procedures.....	20
4.4 Emergency PLC Bypass Operations.....	22
4.5 Lake Level Operations E1071.....	24
4.6 Filter Control Operations E1071.....	25
5.0 Station Maintenance Tasks.....	26
5.1 Preventative Maintenance Schedule.....	27
5.2 PRV Adjustment Procedures.....	29
5.3 Powder Coating Touch-Up Procedure.....	32
5.4 Winterization Procedures.....	34
5.5 Global Service Plan (GSP) Support Instructions.....	40
6.0 Basic Troubleshooting.....	41
6.1 Pump Start Process - Abnormal.....	45
6.2 Cycling of Main Pump(s).....	46
6.3 Failure to Shutdown - Main or PM Pump(s).....	47
6.4 PRV Troubleshooting.....	48
6.5 Phase Monitor Alarm.....	49
6.6 Phase Monitor Major Alarm.....	49
6.7 Low Flow / Sensor Alarm (Flow Meter Fault).....	50
6.8 Flow Sensor Fault, Major Alarm.....	51
6.9 Touch Screen Fails to Power On.....	51
Appendix – A: Pump Curves.....	53
Appendix – B: Approval Drawing.....	55
Appendix – C: Electrical Schematic.....	57
Appendix – D: Installation Instructions.....	59
Appendix – E: Start-Up Procedures.....	65
Appendix – F: Emergency Procedures.....	69
Appendix – G: Optional Item Instructions.....	73
Glossary.....	75

## Rain Bird's Pump Station Professional Customer Satisfaction Policy

Rain Bird guarantees that its pump station will be free of manufacturer defects for one year from date of authorized start-up but not beyond sixteen months from date of invoice. Start-up by other than Rain Bird Authorized personnel will void these terms and conditions.

Provided that all installation, start-up and operation responsibilities have been properly executed, Rain Bird will replace or repair, at Rain Bird's option, any part found to be defective under normal recommended use during the above mentioned period. Repairs performed at Rain Bird's expense must be authorized by Rain Bird prior to repairs being performed. Upon request, Rain Bird shall provide advice on trouble-shooting a defect during the effective period of this Customer Satisfaction Policy. However, no service, replacement or repair under this Customer Satisfaction Policy will be rendered while the customer is in default of any payments due to Rain Bird.

Rain Bird will not accept responsibility for costs associated with the removal, replacement, or repair of equipment in difficult-to-access locations. Difficult-to-access locations include (but are not limited to) locations where any of the following are required:

1. Cranes larger than 15 tons
2. Divers
3. Barges
4. Helicopters
5. Dredging
6. Any other unusual means or requirements

Such extraordinary cost shall be the responsibility of the customer, regardless of the reason requiring removal of the equipment from service.

The terms and conditions of this Customer Satisfaction Policy do not cover damage caused by or resulting from the following:

1. Misapplication, abuse, or failure to conduct routine maintenance (to include winterization / winter lay-up procedures).
2. Pumping of liquids other than fresh water as defined by the U.S. Environmental Protection Agency, unless the pump station is specifically designed to do so.
3. Use of free chlorine or other strong biocides.
4. Exposure to electrolysis, erosion, or abrasion.
5. Presence of destructive gases or chemicals.
6. Over voltage or low voltage.
7. Electrical phase loss or reversal.
8. Exposure to incoming power lacking circuit breaker or fused protection.
9. Using the control panel as a service disconnect.
10. Lightning or other Act of Nature.
11. Failure of pump packing seal (unless the failure occurs on initial start-up).

*The foregoing terms and conditions constitute Rain Bird's entire Customer Satisfaction Policy. Rain Bird does not offer any other or additional warranty, with respect to the pumping system or its components. Rain Bird makes no implied warranty, with respect to fitness for a particular purpose or merchantability of the pumping system or its components. Components manufactured by others (as noted on the Pump Station Quotation) are covered solely by and to the extent of the warranty, if any, offered by the manufacturer. Rain Bird shall not be liable to the customer or any other person or entity for any liability, loss, or damage caused or alleged to be caused, directly or indirectly, by the pump system. Rain Bird shall not be responsible for incidental, consequential, collateral or indirect damages or loss of profit or damages related to the customer's business operations, nor for those caused by Acts of Nature. In no case and under no circumstances shall Rain Bird's liability exceed the Rain Bird Corp's net sale price of the pump system.*

*Laws concerning customer warranties and disclaimers vary from state to state, and therefore some of the foregoing limitations may not apply to you.*

## 1.0 Identify Mechanical Components and Functions

Below are graphical depictions and descriptions of many components utilized in Rain Bird Pump Stations. This section is designed to reduce confusion and misconceptions encountered in the field.

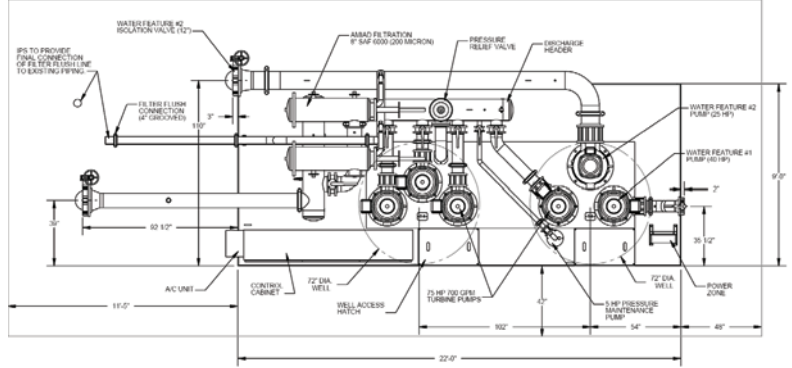

Pumps and Motors			
<p>Horizontal End Suction</p>	<p>Split Case</p>	<p>Submersible Turbine</p>	<p>Vertical Turbine</p>
<p>Vertical Multistage</p>	<p>Trash Pump (with quick disconnect)</p>		

These pumps use centrifugal force via an impeller or series of impellers to generate flow and pressure. Each pump has a theoretical curve with pressure (head) being the vertical axis and flow rate being the horizontal. At 100% speed, the pumps will operate somewhere on this curve so that as flow rate increases the pressure generated decreases. VFD speed control eliminates this rule by adjusting a pump's speed to maintain a set pressure regardless of flow rate that is within the maximum capability of the pump.

- Horizontal End Suction and Split Case pumps typically produce great flow rates at relatively low pressures.
- Vertical Multistage and Submersible Turbine pumps can be mounted vertically or horizontally and have multiple impellers in series that can generate enormous pressures.
- Vertical Turbine pumps are generally used for high flow and high pressure applications such as Golf Courses and large commercial sites.
- Trash Pumps are submersible grinder or sewage pumps and can be mounted with a rail and quick disconnect system for easy maintenance. These pumps generate high flow rates at relatively low pressure.

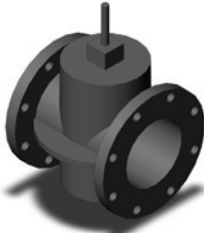

<b>Check Valves</b>			
<p>Wafer Check Valve</p> 	<p>Globe Check Valve</p> 	<p>Swing Check Valve</p> 	
<ul style="list-style-type: none"> <li>• Check valves are mainly used to hold main line pressure when a pump shuts down by allowing flow in only one direction.</li> <li>• The Wafer Check Valves are generally used for most pump discharge applications.</li> <li>• The Globe Check Valves are used when flow rates are exceptionally high and prevent large pressure loss.</li> <li>• The Swing Check Valve is used on most suction lift or low pressure applications.</li> </ul>			
<b>Isolation Valves</b>			
<p>Butterfly Isolation Valve</p> 	<p>Lugged Butterfly Valve</p> 	<p>Gear driven Butterfly</p> 	<p>Gate Valve</p> 
<p>1/4 Turn Ball Isolation Valve</p> 	<p>Plug Isolation Valve</p> 		
<ul style="list-style-type: none"> <li>• Butterfly Isolation Valves are used to hydraulically isolate a pump, PRV, filter or other component.</li> <li>• Lugged Valves are generally used as a Station Discharge Isolation Valve.</li> <li>• Gear Driven Butterfly Valves are used on large pipe diameters requiring great mechanical force to manipulate the disc.</li> <li>• Gate Valves isolate using a plunger type barrier that can be completely removed from the flow stream however are typically larger and more expensive than Butterfly Valves.</li> <li>• 1/4 Turn Isolation Ball Valves are very common and are used for small pipe diameters.</li> <li>• Plug Isolation Valves rotate a large D shaped plug into and out of the flow stream on a asymmetrical cam and are used for very high rates of flow.</li> </ul>			



Control Valves			
<p>Air Relief Valve</p> 	<p>Pressure Relief Valve</p> 	<p>Solenoid Control Valves</p> 	
<ul style="list-style-type: none"> <li>• Air Relief Valves allow entrapped air to escape the column of a Vertical Turbine Pump as it initially starts.</li> <li>• Pressure Relief Valves are safety devices used to vent excessive pressure from the discharge manifold to prevent damage to other components on the station or within the irrigation system.</li> <li>• Solenoid activated Control Valves are used to turn on and off the flow of water. They are used to activate Heat Exchangers, Self Cleaning Intake Screens, Automatic Filter Systems and other devices.</li> </ul>			
Filtration Systems			
<p>Rain Bird BSF 10-8</p> 	<p>Dual Amiad SAF</p> 	<p>Plastic Disk</p> 	<p>Sand Media</p> 
<p>Amiad TAF-750E</p> 	<p>Amiad SAF</p> 	<p>Amiad Filtomat Hydraulic Suction Scanning Filters</p> 	
<ul style="list-style-type: none"> <li>• BSF 10-8 is an example of a Backwashing Screen Filter. The filter requires at least 2 canisters and uses a 3 way solenoid valve to clean each filter by reversing the flow of water from the clean side to the filter flush line. This filter uses stainless steel filter cartridges.</li> <li>• Amiad SAF filters utilize a motorized scanning array of suction nozzles inside a stainless steel filter cartridge. The nozzles vent to atmosphere creating a large pressure differential and high water velocity that pulls solids off the screens.</li> <li>• The Plastic Disk filter uses multiple stacks of plastic disks that create very small yet long apertures. The length of the filters is very good at preventing organic material from extruding through the filter. The filters are cleaned by backwashing the spring loaded stacks causing the disks to separate and flush completely.</li> <li>• The Sand Media filters use a combination of gravel and sand with a specific weight and size to filter organic and other solid mater. The filter requires at least two canisters and uses a backwashing valve for flushing.</li> <li>• The Amiad TAF-750E is a very small version of the SAF and is used on small commercial irrigation systems.</li> <li>• The Amiad Filtomat systems use hydraulic power from the filtered water rather than a motor to run the scanning array which is very similar to the SAF system. The Filtomat systems flush on differential pressure only.</li> </ul>			





## Filtration Systems

<p>Auto flushing Y-Strainer</p> 	<p>VAF</p> 	<p>Tekleen MTF</p> 	<p>Orival</p> 
<p>Brass Wye-Strainer</p> 	<p>Inlet Basket Strainer</p> 	<p>Self Cleaning Intake Strainers with Foot Valves</p> 	



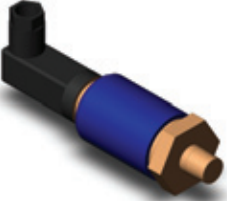
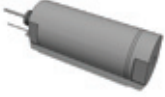



- Auto Flushing Y-Strainer uses a tubular Stainless Steel or plastic screen cartridge to filter out relatively large debris. The flow of water is from the center of the tubular screen cartridge outward thus capturing the debris inline with the flushing valve. When the valve opens to atmosphere the pressure difference forces the filtered debris out through the flush line.
- The small Brass Y-Strainer uses the same type of screen but requires regular manual cleaning.
- Inlet Basket Strainers are typically used on Flooded Suction type Pump Stations and are usually mounted on the suction side of a pump. A simple basket type strainer is used to prevent clogging pump impellers and must be cleaned manually.
- Self Cleaning Intake Strainers are mounted to the end of a suction line for Suction Lift or Flooded Suction type pumping applications. These devices strain water from the outside-in and continuously clean with an array of spray nozzles that spray from the inside-out. Either the screen or the nozzle array rotates to clean the entire screen.
- Foot Valves are usually attached to the Inlet Strainer and are typically a Swing Check or Ball design. The valve limits the direction of flow to prevent water from draining out of the suction line and the loss of prime.

## Sensors and Other Parts

<p>Pressure Gauge</p> 	<p>Pressure Switch</p> 	<p>Pressure Transducer</p> 	<p>Pressure Bladder Tank</p> 
---	--	---	--

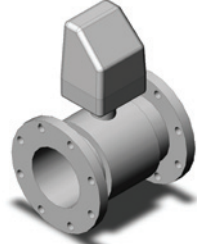
- Pressure Gauges are mechanical liquid filled sensors to continuously display total pressure in a system. A ¼ turn Ball Isolation Valve is usually included for easy maintenance or replacement.
- Pressure Switches provide an electric signal when a specific pressure is exceeded. Some switches are adjustable and others only provide a fixed range.
- Pressure Transducers continuously measure pressure providing a 4-20mA signal that is linearly proportional to the measurable range. For instance, a typical 10Bar transducer that measures 0 to 145PSI will provide 4mA at 0PSI and 20mA at 145PSI.
- Pressure Bladder Tanks use a flexible diaphragm or bladder to separate an air chamber and water volume. Due to the compressibility of air, the volume of the air chamber shrinks when a pump applies pressure to the system and the volume of water expands. When the pump is off, the air provides a relatively constant pressure to the water. When a valve opens or leaks, the air chamber constantly expands as it forces water from the tank into the irrigation system. This reduces the frequency of pump starts to maintain line pressure.

## Sensors and Other Parts

<p>IFM Efactor Flow Switch</p> 	<p>Pulsing Flow Meter (mech)</p> 	<p>SDI Flow Meter (mag)</p> 	<p>Magnetic Flow Meter</p> 
<p>Digital Float Switch</p> 	<p>Ultrasonic Level Sensor</p> 	<p>Push-to-Connect Fitting</p> 	<p>Victaulic &amp; Flange Fitting</p> 

- IFM Efactor Flow Switch detects the flow velocity using a calorimetric measuring principle and switches the output depending on programming.
- Pulsing Flow Meter modulates a 24VDC+ signal with a square wave frequency proportional to the flow velocity. The Pump Station's controls then calculate the flow rate in terms of GPM or m3/h using two parameters, k and offset. The parameters are determined based on the type and diameter of the flow meter spool.
- The SDI and Magnetic Flow Meter create a magnetic field in the flow of water. As the water moves past a sensing coil an electric current is generated and measured. The meter then creates a very accurate 4-20mA signal proportional to the water velocity.
- Digital Float Switches are used to shutoff a station when a low level condition exists or to operate a Lake Level Control Circuit. The switch uses mercury or other tilt type switch to open or close a circuit when the switch floats upwards in the presence of water.
- Ultrasonic Level Sensors (The Probe) are used to shutoff a station when a low level condition exists and/or to operate a Lake Level Control Circuit. The sensor measures the time required for a sound wave to propagate from the sensor to the surface of the water source and back to determine the distance. Using the known distance from the sensor to the bottom of the water source, the Pump Station calculates and displays the actual water level.
- Push-to-Connect Fittings are utilized throughout the Pump Station and are used to quickly connect/disconnect poly control tubing from devices such as the Pressure Transducer, Pressure Gauge, Heat Exchanger and Solenoid Control Valves.
- Victaulic or Grooved Fittings use a rubber seal and metal clamp to connect two pipes. The rubber seal fits between grooves around the outside circumference of each pipe. The metal clamp secures the pipe using the grooves and applies pressure to the rubber seal to prevent leaks.

Use the space below to list and describe any custom parts.

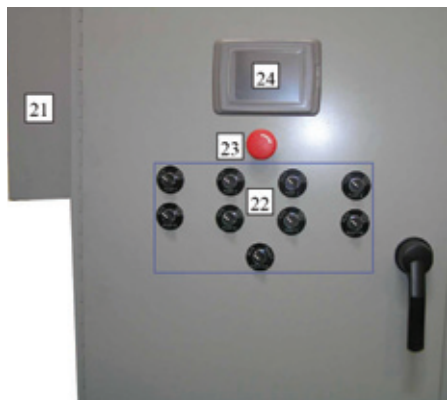
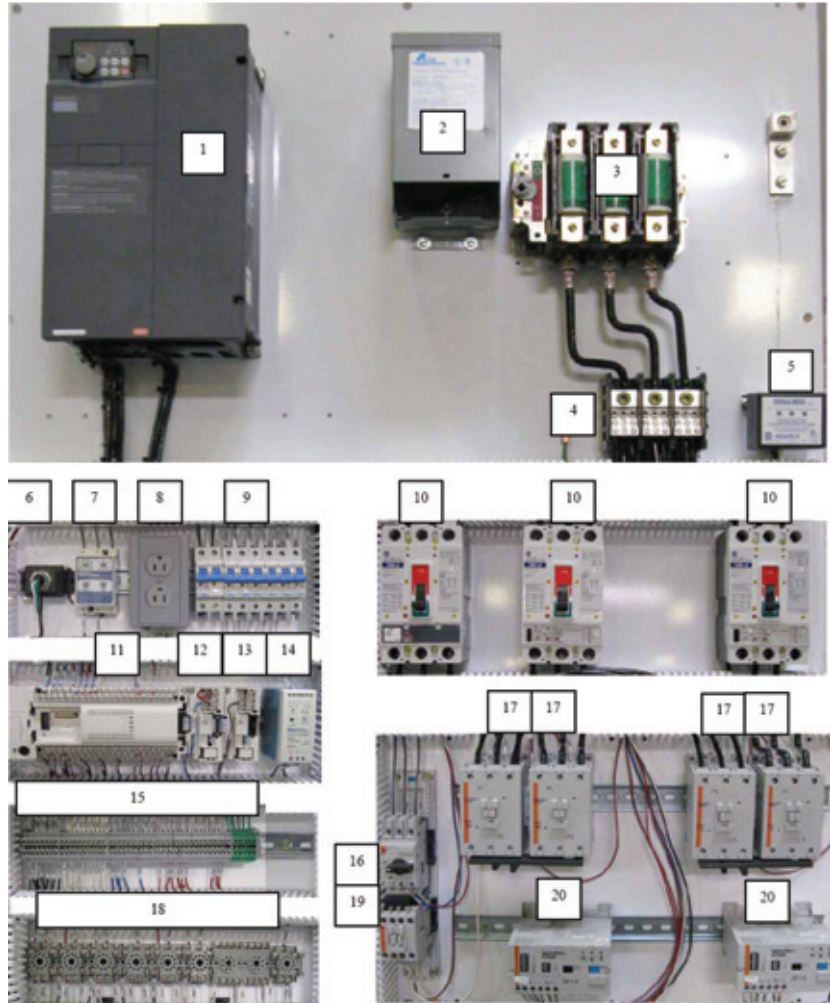

## 2.0 Identify Electrical Components and Functions

1. Variable Frequency Drive (VFD)
2. Control Transformer
3. Disconnect Switch
4. 3 Phase power distribution block
5. Surge Arrestor 3 Phase
6. Surge Arrestor 1 Phase
7. Motor Saver
8. GFI Outlet
9. Control Circuit Breakers
10. Main Motor Circuit Breakers
11. Programmable Logic Controller (PLC)
12. AD Module
13. DA Module
14. 24VDC Power Supply
15. Terminal Strip
16. PM Motor Breaker
17. Main Motor Contactors
18. Control Relays
19. PM Motor Contactor
20. Motor Overload Protectors
21. AC / Heat Exchanger
22. DOL Switches
23. E-Stop
24. Touch Screen
25. Opto Isolator
26. Pressure Transducer

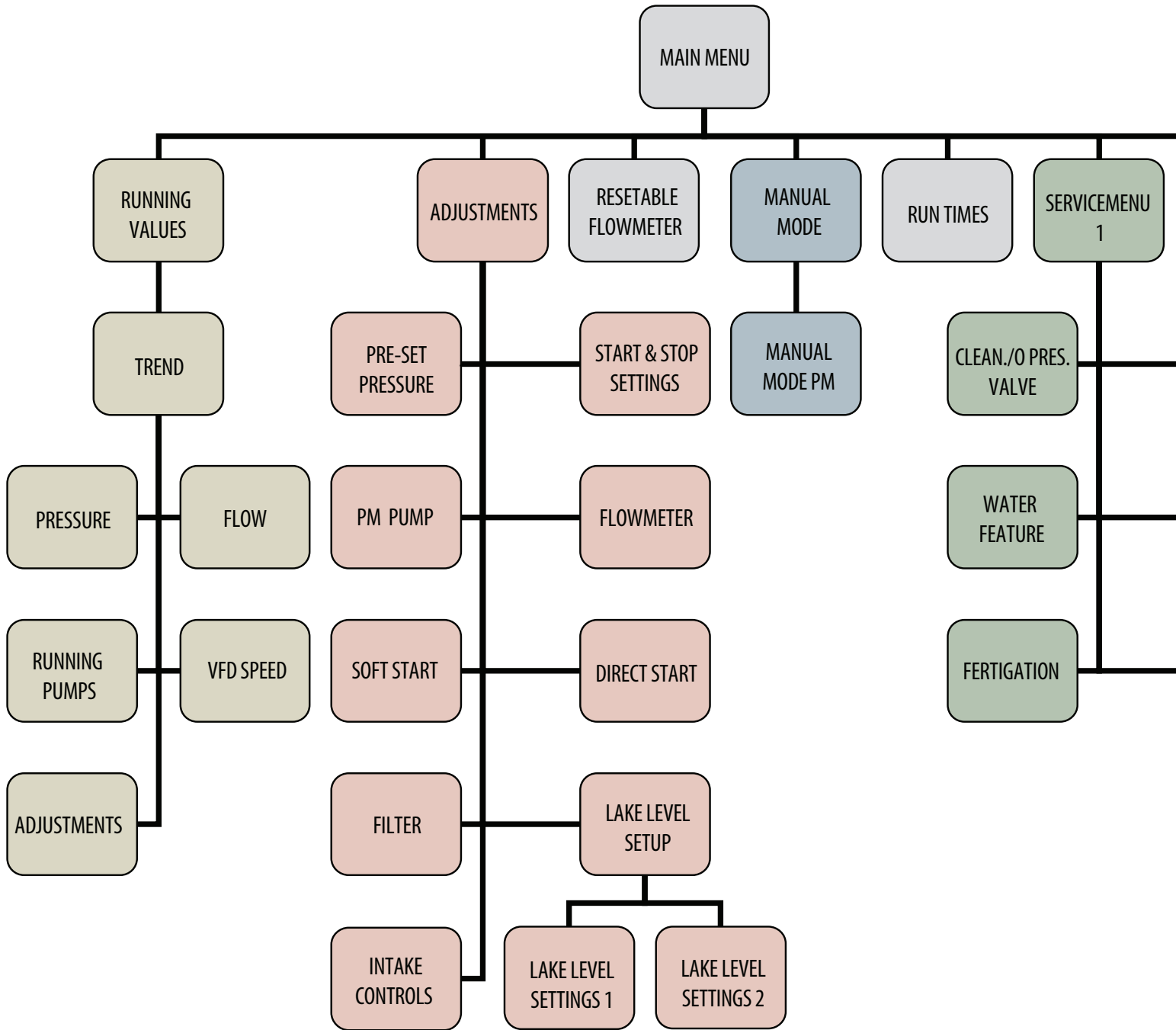

## Touch Screen Architecture

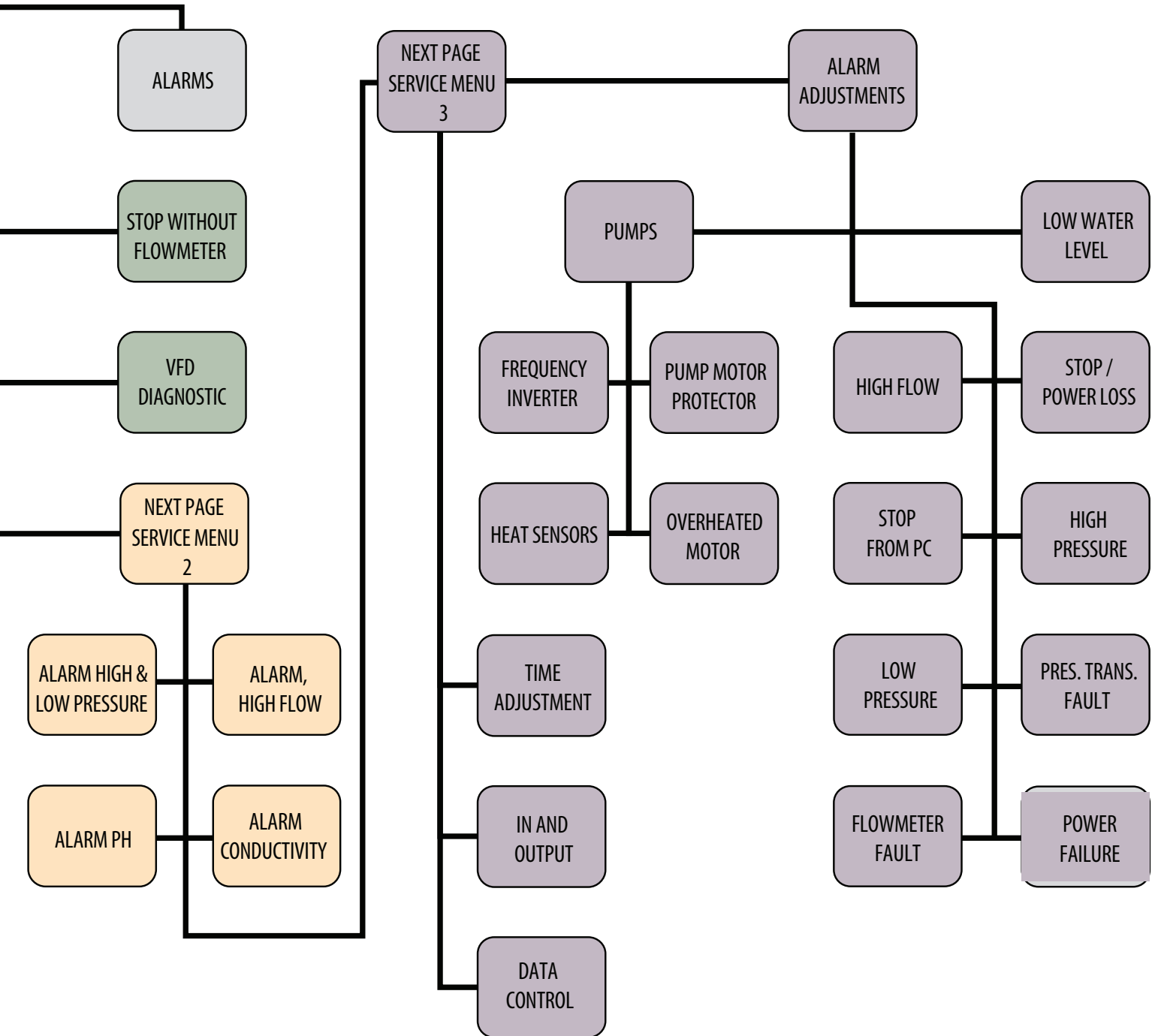



## 3.0 Touch Screen Introduction E1071

This section outlines the basic Touch Screen displays that an Operator will utilize when inspecting or adjusting Pump Station parameters.



### 3.1 Login Codes

Greens Keeper Level 1 - 2058  
Greens Keeper Level 2 - 205850

### 3.2 Basic Navigation

Below are the 7 basic displays with associated subordinate displays accessible with Login Level 2.

1. RUNNING VALUES
  - a. PRESSURE CURVE
  - b. FLOW CURVE
  - c. RUNNING PUMPS CURVE
  - d. VFD SPEED CURVE
  - e. ADJUSTMENTS
2. ADJUSTMENTS
  - a. PRE-SET PRESSURE
  - b. START & STOP SETTINGS
  - c. PM PUMP
  - d. FLOWMETER
  - e. SOFT START
  - f. DIRECT START
  - g. FILTER
  - h. LAKE LEVEL
  - i. INTAKE CONTROLS
3. RESETTABLE FLOWMETER
4. MANUAL MODE
  - a. MAIN
  - b. PM PUMP
5. RUN TIMES
6. SERVICEMENU
  - a. WATER FEATURE
  - b. ALARM HIGH & LOW PRESSURE
  - c. ALARM, HIGH FLOW
  - d. ALARM ADJUSTMENTS
  - e. TIME ADJUSTMENT
  - f. IN AND OUTPUT
7. ALARMS

### 3.3 Pump Status Buttons

- Grey - Disabled and off.
- Yellow - Enabled and off (not running).
- Blue - Operating with VFD speed control.
- Green - Operating at 100% speed or Direct On Line (DOL).
- Red - Fault and/or overload detected, pump is disabled.

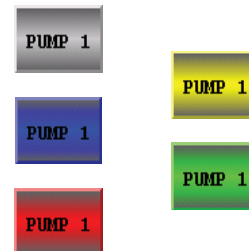



### 3.4 Parameter Definition and Adjustments E1071

MAIN MENU	Parameters		Definition
ADJUSTMENTS			
PRE-SET PRESSURE			
<b>PRESET PRESSURE:</b>	psi		Station's set point pressure to maintain.
REDUCE WITH EXT SIGNAL:	psi		Option to reduce set point pressure upon external signal.
REDUCTION AT 1, 2, 3 OR 4 PUMPS:	psi		Option to reduce Pre-Set Pressure upon activation of a pump(s).
<b>START &amp; STOP SETTINGS</b>			
STARTMARGIN LARGE UNDERPRESSURE:	psi	sec	Pumps will start when the discharge pressure is below the Pre-Set Pressure by this margin and duration.
STARTMARGIN SMALL UNDERPRESSURE:	psi	sec	
DELAY START 2ND PUMP:		sec	Prevents premature start and short cycle of the next pump.
STOPMARGIN LARGE OVERPRESSURE:	psi	sec	Pumps will shutdown when the discharge pressure is above the Pre-Set Pressure by this margin and duration.
STOPMARGIN SMALL OVERPRESSURE:	psi	sec	
<b>ADJUSTMENTS PM PUMP</b>			
PM PUMP INSTALLED:	No / Yes		Is a Pressure Maintenance Pump Installed? Yes or No?
ON AT IRRIGATION:	No / Yes		Is the PM allowed to operate during a normal irrigation?
PM PUMP WITH VFD:	No / Yes		Is the PM VFD controlled?
STARTMARGIN:	psi	sec	The PM will start/stop when the actual discharge pressure is above/below the Pre-Set Pressure by this margin and duration.
STOPMARGIN:	psi	sec	
STOP AT FLOW:	gpm		The PM will shutdown when the flow rate exceeds and then drops below this parameter.
<b>ADJUSTMENTS FLOWMETER</b>			
FLOWMETER INSTALLED	No / Yes		Is there a flow meter installed?
GO TO IRRIGATION AT:	gpm		Second pump start is inhibited until the flow rate exceeds this parameter.
STOP IRRIGATION AT:	gpm		Main pumps will shutdown when the flow rate exceeds and then drops below this flow rate and time duration.
STOP DELAY:	sec		
<b>ADJUSTMENTS SOFT START</b>			(Pipe Saver)
SOFT START ACTIVATED:	No / Yes		Is Soft Start Activated?
LOW PRESSURE WHEN SOFT START ON:	psi		If discharge pressure drops below the Pre-Set Pressure by this specified margin, the VFD speed will be adjusted as necessary to increase pressure 1.4PSI per specified time period.
DELAY PRESSURE RISE:	sec		
<b>SETTINGS DIRECT START</b>			
START WITHOUT VFD:	No / Yes		Are pumps allowed to start DOL when VFD is disabled?
<b>AUTO-BACKWASHING FILTER</b>			
NUMBER OF FILTER ELEMENTS:	#		List the number of filter canisters.
TYPE:	Amiad/RainBird/Other		Select Amiad, Rain Bird or Other.
BACKWASH TIME PER ELEMENT:	sec		Cleaning time required for each canister.
TIME BETWEEN BACK WASHES:	hrs		Hours of Irrigation between cleaning cycles.



MAIN MENU	Parameters		Definition
<b>ADJUSTMENTS</b>			
<b>AUTO-BACKWASHING FILTER</b>			
FIRST FLUSH TIME:	hrs		Time of day for first/second independent cleaning cycles. 24 hour clock. '-1' disables the cycle.
SECOND FLUSH TIME:	hrs		
ENABLED/DISABLED:	Enabled / Disabled		Enabled or Disabled the auto cleaning cycles.
<b>SERVICE-MENU 1</b>			
<b>STOP WITHOUT FLOW METER</b>			N/A if a operational flow meter is installed.
VFD #1 STOP LIMIT:	%	sec	The pumps will shutdown when the actual VFD speed drops below this speed for the time listed.
VFD #2 STOP LIMIT:	%	sec	
VFD #3 STOP LIMIT:	%	sec	
<b>WATER FEATURE MANAGEMENT</b>			Option to start/stop a water feature pump if installed.
<b>FERTIGATION CONTROL</b>			Option to enable or disable high and low flow rate fertigation signals
<b>SERVICE-MENU 2</b>			
<b>ALARM HIGH &amp; LOW PRESSURE</b>			
ALARM LIMIT: (HIGH)	psi	sec	Margin and duration above Pre-Set Pressure.
ALARM MARGIN LOW PRESSURE:	psi		Margin below Pre-Set Pressure.
DELAY WITHOUT SOFT START:	min		Low Pressure Duration with Soft Start Disabled.
DELAY WITH SOFT START:	min		Low Pressure Duration with Soft Start Enabled.
<b>ALARM, HIGH FLOW</b>			
ENABLED:	En / Dis 1H / Dis		Enable or (temporarily) Disable High Flow Alarm.
FLOW PUMP:	gpm	min	Flow rate and duration required for Alarm.
<b>SERVICE-MENU 3</b>			
<b>ALARM ADJUSTMENTS</b>			Configure alarm behavior settings for Pumps, Low Water Level, High Flow, E-Stop, Stop from PC, High Pressure, Low Pressure, Transducer Fault, FM Fault and Power Failure.
<b>TIME ADJUSTMENT</b>			
TIME			Set the system time, 24h clock (0000 is midnight)
DATE			Set the system date, MM/DD/YY
<b>IN AND OUTPUT</b>			Troubleshoot by viewing PLC input and output status.

**NOTE:** The above items in BOLD should be clearly understood by the Operator.

## 4.0 Normal Pump Station Operations

The following chapter describes procedures normally conducted during regular Pump Station operations. The following topics will be discussed:

4.0	Normal Pump Station Operations .....	17
4.1	Alarm Reset Procedures E1071 .....	18
4.2	Manual VFD Operations E1071 .....	19
4.3	Start-Up Procedures.....	20
4.3.1	Empty Pipe.....	20
4.3.2	Full Pipe - depressurized.....	21
4.4	Emergency PLC Bypass Operations.....	22
4.4.1	Required Items .....	22
4.4.2	Prepare Pump Station for Emergency PLC Bypass .....	22
4.4.3	Optional .....	22
4.4.4	Begin Irrigation .....	23
4.4.5	End Irrigation .....	23
4.4.6	Return station to automatic operation (when practical) .....	23
4.5	Lake Level Operations E1071.....	24
4.5.1	Digital Float Switches.....	24
4.5.2	Ultrasonic Sensor (Analog) .....	24
4.6	Filter Control Operations E1071 .....	25

## 4.1 Alarm Reset Procedures E1071

When an alarm condition exists, the ALARM Status Button turns red. Press the ALARM Status Button once to view the alarm description.

Active alarms are highlighted in red and are preceded by a dash, '-'. Press and hold the RES (RESET) button for 2.5 seconds to clear the active alarm. When cleared, the highlight and dash will extinguish however the alarm description will remain for historical purposes. If the alarm persists, troubleshoot the condition using the Section 6.0 Basic Troubleshooting. Contact Rain Bird GSP if unable to clear the alarm.

Each alarm function/action is setup in the E1071 SERVICE-MENU 3 – ALARM ADJUSTMENTS display to post either a warning (soft alarm) or stop the Pump Station operation (hard alarm).

**NOTE:** If the Pump Station is linked to RB Pump Manager and Smart Pump software, the Central Control software may also post these alarms.

Some of the alarms that may be seen include but are not limited to:

1. STOP FROM PC
2. HIGH PRESSURE / BLOCKED
3. HIGH FLOW
4. LOW PRESSURE / BLOCKED
5. PRESSURE SENSOR / BLOCKED
6. FLOW METER FAULT / BLOCKED
7. LOW LEVEL / BLOCKED
8. 3 PHASE POWER FAIL
9. VFD TRIPPED
10. MOTOR 1, 2, 3, 4, JOCKEY HEAT SENSOR
11. MOTOR 1, 2, 3, 4, JOCKEY TRIPPED
12. PLC BATTERY LOW
13. E-STOP INTERNAL

## 4.2 Manual VFD Operations E1071

**CAUTION:** Disable every pump before proceeding. Failure to disable every pump will cause the pump(s) to start DOL at 100% speed.

**CAUTION:** Every enabled pump, other than the selected ADJUSTABLE PUMP, will run at 100% speed when the RUN MODE is set to MAN.

1. From the MAIN MENU, Log in with level 2. (205850)
  2. Select the MANUAL MODE display from the MAIN MENU. The RUN MODE should still display AUTO.
  3. Select any VFD driven pump with the ADJUSTABLE PUMP drop down menu.
  4. Set the VFD speed as desired. This may be done via the speed select slider bar or the digital SPEED OF PUMP display.
  5. Change the RUN MODE to MAN.
  6. Enable the selected VFD driven pump listed on the ADJUSTABLE PUMP drop down menu. The pump will start and ramp to the selected speed.
- NOTE:** Some Vertical Turbine pumps require 50% as a minimum start speed as 40% is too slow to overcome impeller inertia and mechanical seal friction.
7. Adjust the speed as desired. Monitor pressure and flow rate in the window bottom center of the MANUAL MODE display.
  8. Shut down pumps.
    - a. Disable pump(s)
    - b. Select None on the ADJUSTABLE PUMP drop down menu.
    - c. Change the RUN MODE to AUTO.
    - d. Enable pump(s) as desired for automatic operation.

**NOTE:** The Speed Select Slider Bar is limited to 5% speed increments. The Digital Input is limited to 0.1% increments.

**NOTE:** The MAN MODE button in the lower right hand corner is an indicator only. It will flash if the Pump Station is in Manual Mode.

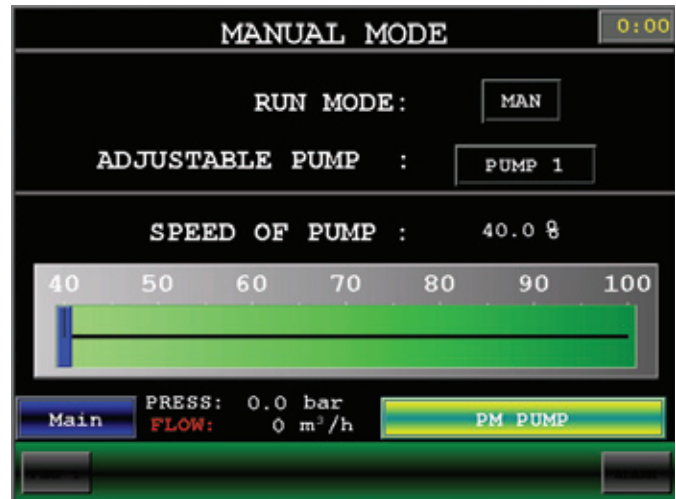

## 4.3 Start-Up Procedures

**Table 1: Max Fill Flow Rate**

Pipe Dia	2"	3"	4"	6"	8"	10"	12"	14"	16"	18"	20"	22"	24"
Max GPM	10	30	55	130	235	365	525	715	940	1150	1450	1750	2100

Below are the recommended procedures for re-starting the Pump Station with an empty pipe such as after winterization, and a full but depressurized pipe such as after a fault or inadvertent shutdown during irrigation.

**CAUTION:** The Operator is strongly advised to limit the flow rate throughout the Start-Up Procedure to the maximum shown in Table 1 above. Failure to do so may result in damage to the irrigation system.

### 4.3.1 Empty Pipe

1. Station Preparation
  - a. Disable all pumps on the Touch Screen.
  - b. Ensure all pump station piping and equipment are reassembled and all drain valves have been closed.
  - c. Adjust Station Discharge Isolation Valve to 90% closed.
2. Slowly fill station and irrigation mainline.
  - a. Run the PM pump for short durations 2 or 3 times to check for leaks in the pump station piping. Use the AUTO/EMER RUN Switch or PM Manual Mode Display. (If Installed)
  - b. Reduce the PRE-SET Pressure 30% below normal irrigation pressure.
  - c. Open 4 – 6 irrigation heads at the furthest points in the irrigation system. Be sure to use different zones to fill large lateral lines and allow air to escape the system. More heads may be necessary depending on the irrigation design and volume.
  - d. Ensure the station is in automatic mode and enable one main pump. A jockey may be used if it is VFD controlled.
  - e. Adjust the Station Discharge Isolation Valve until the maximum fill flow rate is achieved. Use the chart above to determine the maximum flow rate based on the irrigation main line diameter. This flow rate will fill 100ft of pipe in approximately one minute and a mile of pipe in about an hour.
  - f. Run system until only water, no air, is exiting each irrigation head.
3. After the main line is full and pressurized:
  - a. Close the irrigation heads or valves in at least two (2) minute increments and ensure the station shuts down properly.
  - b. Verify the pressure remains fairly constant and does not immediately drop.
  - c. Adjust the PRE-SET pressure to the desired irrigation pressure.
  - d. Verify the pump starts again and pressurizes the main line to irrigation pressure.
  - e. Manually flush filters (if installed) before the station automatically shuts down.
4. Slowly open the Discharge Isolation Valve to the full open position.
5. Enable pumps as desired.

### 4.3.2 Full Pipe - depressurized

There are two techniques for pressurizing a full irrigation main. The Automatic Technique using the SOFT START option or the Manual Technique using the MANUAL MODE display. The Automatic Technique requires SOFT START enabled with appropriate parameters set.

1. Automatic Technique
  - a. Check SOFT START is enabled.
  - b. Verify parameters.
  - c. Enable one main pump. The SOFT START control circuit will slowly and automatically increase pressure 1.4PSI per specified time period. For example, it will require approximately 6 minutes to increase pressure from 0PSI to 120PSI with 1.4PSI increase per 4 seconds.

**CAUTION:** The Automatic Technique should only be used if the main line is full of water. Damage to the irrigation system may occur if employed on an empty pipe.

2. Manual Technique (review Manual VFD Operations)
  - a. Ensure all pumps are disabled.
  - b. Using the MANUAL MODE display, select one VFD controlled pump and set to 40% speed.

**NOTE:** Some Vertical Turbine pumps require 50% as a minimum start speed as 40% is too slow to overcome impeller inertia and mechanical seal friction, however once started may slow to 40% without tripping a motor protector.

- c. Monitor the flow rate and pressure. Expect some transients, however once the flow rate returns to 0 GPM and pressure stabilizes, increase speed to 45%.
    - d. Continue to incrementally increase the VFD speed while waiting for the flow rate and pressure to stabilize before continuing.
3. Once desired pressure is reached:
  - a. Set MANUAL MODE to AUTO – pump(s) will automatically disable.
  - b. Enable pump(s) as desired.

## 4.4 Emergency PLC Bypass Operations

Due to acts of nature, lightning strikes or other situations, the PLC, Touch Screen or VFD may become damaged and rendered inoperable. In order to save expensive turf investments it may be necessary to bypass the damaged PLC or VFD to continue irrigating. There are many techniques, however Rain Bird recommends the following for simplicity and safety. Circuit Breaker motor protection and phase loss will be the only operational safeties.

### 4.4.1 Required Items

1. Pump Curve
2. Pump Station Pressure Limitations
3. Irrigation System Pressure Limitations
4. Open-end Wrench (1/2" or 3/8") appropriate for PRV Pilot Valve Adjusting Screw.

**CAUTION:** If pressure is allowed to build above the rated operating pressure for any installed component, damage to the equipment may occur.

**WARNING:** Automatic pressure control and electronic safeties are not available during PLC Bypass Operations.

**WARNING:** Continuously monitor the Pressure Gauge on the discharge header. If pressure is allowed to build above the rated burst pressure for any installed component, catastrophic damage may occur and possibly cause death or serious injury.

### 4.4.2 Prepare Pump Station for Emergency PLC Bypass

1. Ensure all individual Pump Isolation Valves are fully open to avoid building high air pressure upon startup of Vertical Turbine pumps.
2. Ensure all Air Relief Valves are operational.
3. Check the PRV Isolation Valve, if installed, is open.
4. Check the PRV and temporarily adjust lower. Loosen the adjusting screw until it starts to vent at the desired discharge pressure, then tighten adjusting screw ¼ turn.
5. Adjust the Station Discharge Isolation Valve to between ¼ and ½ open. This will act as a pressure reducing valve during dynamic flow and provide some level of safety for the irrigation piping network.

**NOTE:** Count the threads on the PRV adjusting screw before changing in order to quickly return to the previous set point.

### 4.4.3 Optional

1. Install a quick coupler down stream of the Station Discharge Isolation Valve. Install a high pressure hose fitted with a Pressure Gauge on the quick coupler and run to the pump house for accurate main line dynamic pressure readings. The manifold pressure will be significantly higher than the mainline due to the pressure drop over the adjusted Discharge Isolation Valve.
2. Bypass automatic filtration systems if desired or if pressure becomes difficult to maintain below 150PSI or the filter's maximum operating pressure.

**CAUTION:** Ensure all individual pump AUTO/EMER RUN switches are in the AUTO or OFF position. Failure to do so will result in multiple pumps starting across the line simultaneously thus causing large amperage, pressure and flow surges.



#### **4.4.4 Begin Irrigation**

1. Identify the EMER RUN AUTO/ENABLE Switch – select ENABLE (if installed). No pumps should come on yet. Some stations with a single pump do not include this switch.
2. Create Irrigation Demand. Open valves or zones to create a pressure drop and flow demand at or slightly above the design point of one main pump. Reference the pump curve.
3. Identify the desired pump AUTO/ENABLE Switch – select ENABLE. The selected pump should start at 100%.
4. Monitor the pressure on the Discharge Manifold and on the irrigation main line if Optional step 4.4.3 was completed.
  - a. Adjust the Station Discharge Isolation Valve to manage the irrigation line pressure.
  - b. Open/Close irrigation valves as necessary to manage the total system pressure. The more flow demanded, the less pressure the pump can produce. See pump curve for details.
  - c. Adjust the PRV as necessary to maintain pressure below upper limit (See section 5.2 PRV Adjustment Procedures).
  - d. Repeat steps (2) – (4) as necessary until desired flow rate is achieved.

#### **4.4.5 End Irrigation**

1. Identify a running pump AUTO/ENABLE Switch – select AUTO. The pump should shutdown.
2. Reduce flow demand by closing valves or zones as necessary to manage pressure.
3. Repeat steps (1) and (2) as necessary until all pumps are off.
4. Identify the EMER RUN AUTO/ENABLE Switch – select AUTO (if installed).

#### **4.4.6 Return station to automatic operation (when practical)**

1. Return PRV Pilot Valve Adjusting Screw to original setting (See section 5.2 PRV Adjustment Procedures).
2. Remove quick coupling and hoses (if used).
3. Open the Station Discharge Isolation Valve to the full open position.
4. Enable automatic filtration systems (as necessary).

## 4.5 Lake Level Operations E1071

This section describes the LAKE LEVEL SETTINGS display and all applicable Login Level 2 parameters.

### 4.5.1 Digital Float Switches

Stations with a single float provide simple on/off control. The LAKE FILL ON TIMER sets the amount of time (seconds) the float must be dry before the lake fill control circuit enables a pump or valve to fill the lake. The LAKE FILL OFF TIMER sets the amount of time (seconds) the same float must be wet before the control circuit disables the fill pump or valve.

Stations with two Float Switches provide more control. The two timers explained above have the same purpose; however the LAKE FILL ON TIMER begins when the lower float is dry and the LAKE FILL OFF TIMER begins when the upper float is wet.

A third Float Switch is typically the lowest float and is used as a low level safety to prevent pumps from operating when insufficient water is available. The low level safety is independent from the lake level control and is required on Submersible and Vertical Turbine pumps.

### 4.5.2 Ultrasonic Sensor (Analog)

Analog level control requires the Ultrasonic Lake Level Sensor; see The Probe Setup Instructions for details on configuring the sensor.

The Analog LAKE LEVEL SETTINGS display shows graphically the measured lake level as well as the selected start/stop fill levels and high/low level alarms. The display also provides three timers to prevent short cycling of valves or pumps as well as preventing nuisance low level alarms.

These settings may be adjusted by pressing the digital numerical display next to the setting name. The Low Level setting can only be adjusted by an authorized service provider. The Function drop down menu allows the Operator to manually control the lake fill/dewater functions.

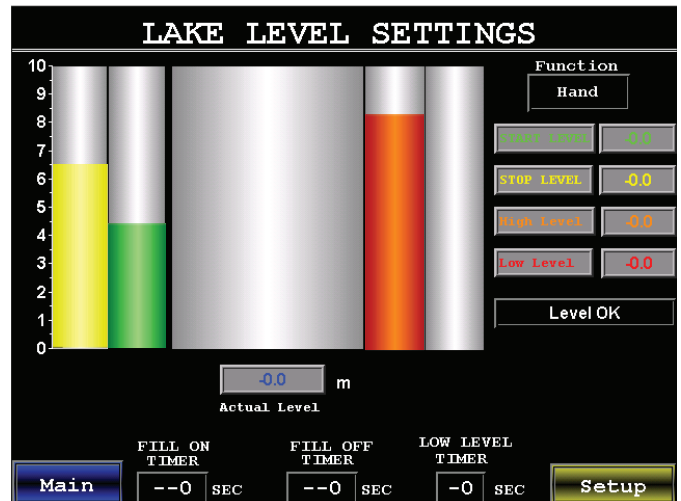

The LAKE FILL ON TIMER sets the amount of time (seconds) the measured level must be below the green START LEVEL setting before the lake fill control circuit enables a pump or valve to fill the lake.

The LAKE FILL OFF TIMER sets the amount of time (seconds) the measured level must be above the yellow STOP LEVEL setting before the control circuit disables the fill pump or valve.

The LOW LEVEL TIMER sets the amount of time (seconds) the measured level must be below the Low Level setting before the respective alarm annunciates.

## 4.6 Filter Control Operations E1071

The AUTO-BACKWASHING FILTER display is accessed from ADJUSTMENTS. This provides the only interface to control an optional Automatic Filter. The Operator will properly configure these parameters based on the installed equipment.

Configure the AUTO-BACKWASHING FILTER display in the following manner:

1. NUMBER OF FILTER ELEMENTS. Enter the number of filter canisters or devices installed on the Pump Station. For example a wye strainer would be 1, where a Rain Bird BSF 10-2 would be 2.
2. TYPE: - used to select the type of installed filtration system.
  - a. RAIN BIRD – used for Back Washing screen Filters (BSF) and wye strainers.
  - b. AMIAD – used for suction-Scanning Automatic Filtration (SAF).
  - c. VAF – used for Valve and Filter systems.
  - d. TEKLEEN – used for Tekleen suction-scanning filter systems.
3. BACKWASH TIME PER ELEMENT (sec.) is normally set between 25-30 seconds. This may be adjusted based on water quality or by filter manufacturer specifications.
4. TIME BETWEEN BACK WASHES (0 = none) has a range of 0 to 24 hours. If zero (0) is entered this feature is disabled. Entering any number between 1 and 24 will result in a cleaning cycle after the specified amount of pump run hours.
5. FIRST / SECOND FLUSH TIME allows the Operator to enter two cleaning times during the day. The time is entered using a 24 hour clock (0000 = midnight, 1200 = noon and 2200 = 10 PM). Disable this feature by entering a “-1” in the hour field.
6. NUMBER OF FLUSHES displays the accumulated number of cleaning cycles since the last reset event provided by the RESET button.
7. The MANUAL START button will initiate a cleaning cycle as long as the following conditions are met:
  - a. At least one pump is enabled.
  - b. The filter is not already in a cleaning cycle.
  - c. ENABLED/DISABLED button is set to ENABLED.
  - d. Filter alarms or faults are not present.
8. The ENABLED / DISABLED button toggles the automatic cleaning feature.

**NOTE:** Filters equipped with a Pressure Differential Switch will also initiate a cleaning cycle without warning upon a 7PSID between the inlet and outlet of the filter.

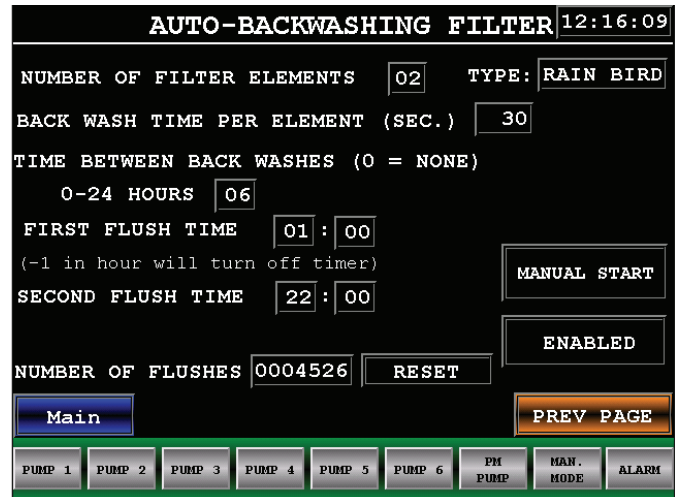



## 5.0 Station Maintenance Tasks

The following section discusses preventative maintenance and other regular tasks to enhance the Pump Station's service life and prevent damage. Most Pump Station maintenance tasks should be accomplished by a trained Authorized Service Provider (ASP) due to inherent danger from high voltage, high pressure and rotating equipment as well as required specialized skills.

As a minimum the Owner/Operator should ensure the Preventative Maintenance Schedule is adhered to, Touch-Up and Winterization Procedures are accomplished when necessary. Perform only those tasks that can be accomplished safely with the proper equipment, tools and training. Contact Rain Bird GSP to schedule all others. See the available Rain Bird Preventative Maintenance Plans by contacting Rain Bird Services Corporation (RBSC) at (888) 444-5756 followed by option 1, option 2 (the options may change periodically).

5.0	Station Maintenance Tasks .....	26
5.1	Preventative Maintenance Schedule .....	27
5.2	PRV Adjustment Procedures .....	29
5.2.1	Initial Site Preparation .....	29
5.2.2	PRV Preparation .....	29
5.2.3	Touch Screen Preparation .....	30
5.2.4	PRV Adjustment Procedure .....	30
5.2.5	Site Completion .....	31
5.3	Powder Coating Touch-Up Procedure .....	32
5.3.1	Color Match Information .....	33
5.4	Winterization Procedures.....	34
5.4.1	Initial Conditions and Precautions.....	35
5.4.2	Winter Shut-Down Procedure.....	35
5.5	Global Service Plan (GSP) Support Instructions.....	40

## 5.1 Preventative Maintenance Schedule

**WARNING:** The following preventative maintenance items should only be performed by a Service Provider trained to repair and maintain electrical and rotating equipment.

**CAUTION:** Immediately remove rust and corrosion from damaged areas and apply touch up paint in accordance with the Powder Coating Touch-Up Procedure. Failure to do so will result in reduced service life and possible unsafe conditions.

1. 90 days following initial Pump Station Start-Up:
  - a. De-energize the Pump Station and check tight all terminal connections and all plumbing connections.
  - b. Remove any debris from Control Panel interior.
2. Daily: Perform a cursory visual inspection of the Pump Station/Pump House.
3. Weekly: Perform a detailed visual inspection of the Pump Station/Pump House.
4. Monthly Tasks:
  - a. Check condition and security of all installed equipment.
  - b. Check for leaks and blockage of drain lines and control tubes.
  - c. Check for signs of rust and corrosion.
  - d. Check for any alarm conditions.
  - e. Wash down Pump Station skid and piping (do not wash down Pump Station motors or other electrical components).
  - f. Vacuum Control Panel interior.
5. Semi-annual Tasks:
  - a. De-energize the Pump Station and check tight all terminal connections and all plumbing connections.
  - b. Clear Control Panel heat exchanger and heat exchanger intake and discharge lines with compressed air.
  - c. Clean all Y-Strainers (Heat Exchanger, PRV, Self Cleaning Intake flush line, etc).
  - d. Change oil on Vertical Hollow-Shaft Motors.
  - e. Clear Vertical Turbine Wet-Well return/drain lines with compressed air.
  - f. Clean and inspect Pressure Transducer. Remove and clear the Pressure Transducer hydraulic signal line with compressed air.
  - g. Apply power to station.
  - h. Check status of Surge Arrestors. (LED's should be illuminated)
  - i. Check Packing Gland for proper bleed rate on Vertical Turbine pumps equipped with Mechanical Seals).
  - j. Verify pump motor ampere draws closely match nameplate FLA.
  - k. Flow test station up to design flow rate and back to zero. Ensure pumps start/stop in sequence properly.

6. Annually:
  - a. Perform the Motor Insulation Test Procedure on all pump motors. Record the values and keep record that allows year-to-year comparison.
  - b. On Pump Stations equipped with automatic filtration:
    1. Close the main Inlet/Discharge Isolation Valve(s).
    2. De-energize and de-pressurize the Pump Station.
    3. Remove and power wash each filter screen.
    4. Inspect the filter components in accordance with the filter's manufacturer recommendations.
  - c. Verify individual pump performance at specified duty point against pump curve.
  - d. Install a rebuild kit on the PRV and adjust relief set-point to 110% of system operating pressure.
  - e. Inspect all Contactors and Relays. (Power OFF)
  - f. Inspect and tighten all electrical terminals and lugs. (Power OFF)

**CAUTION:** If the Pump Station is located in a climate where temperatures are anticipated to drop below 32°F (0°C), winterize the Pump Station per the Winterization Procedure in the Rain Bird Pump Station Manual.

**CAUTION:** Do not store anything (equipment, rotors, painting supplies, food, clothing, etc.) on the Pump Station Piping, Skid or Control Panel. Stored items on the Pump Station may cause or contribute to corrosion and is a safety hazard.

**NOTE:** The above schedule outlines the minimum required maintenance to ensure a long service life and reliable performance. Additional inspections and more frequent cleaning cycles may be necessary depending on the water quality or as desired.

## 5.2 PRV Adjustment Procedures

**CAUTION:** Installation, electrical connection, set-up, operation, and maintenance of the pump station must only be carried out by qualified personnel authorized by Rain Bird GSP.

**CAUTION:** Pump volute temperature should be monitored after more than 5 minutes of operation at or near zero flow. If volute temperature exceeds 140° the pump should be shutdown and allowed to cool to prevent catastrophic damage to shaft seals, o-rings and PVC components.

**WARNING:** The Pressure Relief Valve is a hydraulic safety for the pump station. Any adjustment will influence the level of safety for equipment and personnel. Only qualified personnel familiar with the pressure ratings of every component on the pump station may adjust the PRV.

### 5.2.1 Initial Site Preparation

1. Disable all pumps on the Touch Screen. Inadvertent activation of a pump later in this operation may cause damage to the station. Each Pump Status Button should be grey.
 

PUMP 1
2. Set pump station valves.
  - a. Close station discharge isolation valve.
  - b. Ensure all PRV control valves and isolation valves are open.
  - c. Ensure the pump(s) and station inlet isolation valves are open.
  - d. Isolate any filtration systems, bladder or pressure tanks and any other pressure sensitive components from the discharge manifold to mitigate risk of bursting due to overpressure.

### 5.2.2 PRV Preparation

1. Remove the protective plastic cap, if installed, from the pilot control valve (CRL item #3).
2. Adjusting screw
  - a. Loosen the hex jam nut or locking nut on the CRL adjusting screw.
  - b. Tighten the adjusting screw two (2) to three (3) turns Clock Wise (CW).
3. Speed control (X42N-2 Strainer Needle Valve item #2)
  - a. Loosen the hex jam nut or locking nut on the speed control set screw.
  - b. Tighten set screw with a flat head screw driver until it seats (CW).
  - c. Loosen ½ turn (CCW).

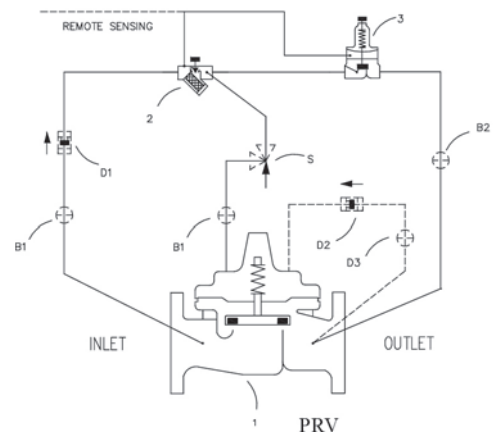

PRV Schematic

CLA-VAL Copyright Cla-Val 2007 Printed in USA  
 Specifications subject to change without notice.  
 P.O. Box 1325 • Newport Beach, CA 92659-0325  
 Phone: 949-722-4800 • Fax: 949-548-5441  
 E-mail: claval@cla-val.com • Website cla-val.com  
 © N-RK (R-5/07)



## 5.2.3 Touch Screen Preparation

1. From the MAIN MENU, Log in with level 2. (205850)
2. Select the MANUAL MODE display from the MAIN MENU.
  - a. Select any VFD driven pump with the ADJUSTABLE PUMP drop down menu.
  - b. Set the VFD speed to 40%. This may be done via the speed select slider bar or the digital SPEED OF PUMP.
  - c. Change the RUN MODE to MAN.

**NOTE:** No pump should be running at this point as all pumps have been previously disabled.

**NOTE:** The speed select slider bar is limited to 5% speed increments. The digital input is limited to 0.1% increments.

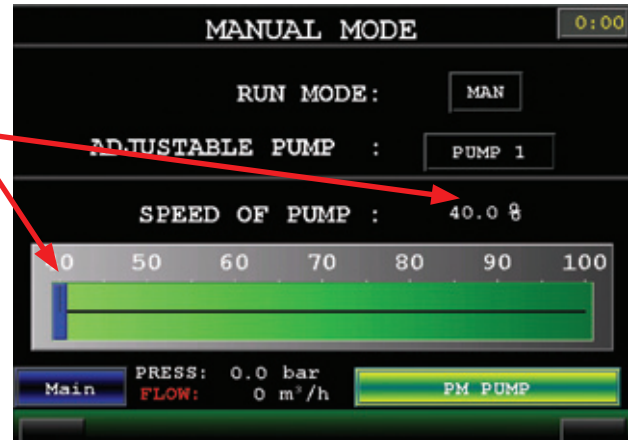

## 5.2.4 PRV Adjustment Procedure

1. Choose the PRV vent pressure. This will be 110% of the PRESET pressure and at least 15PSI less than the maximum pressure rating of the most sensitive installed component. Example: a 120PSI station with automatic filtration. The burst limit on the filter body is 200PSI but the flush control valve is rated at 150PSI. The PRV vent pressure should be from 130PSI to 135PSI.
2. Enable the selected VFD driven pump. The pump should start and ramp to 40%.

**CAUTION:** Enabling any pump other than the selected ADJUSTABLE PUMP will engage the pump's DOL contactor and it will start at 100% speed.

3. Incrementally increase the VFD speed until the pressure builds to the desired PRV vent pressure. Use the slider for rough adjustments and the digital input to fine tune within a few PSI of the desired vent pressure.
4. Slowly turn the CRL adjusting screw CCW just until the valve begins to vent.
5. Take note of the current VFD speed then reduce speed to 40%.
6. Verify discharge pressure reduces and the PRV closes.
7. Increase speed directly to the noted speed in step 5 and verify PRV vents.
8. Repeat steps 3 – 7 until desired operation is achieved.
9. Return RUN MODE to AUTO when complete. Pumps should remain disabled.

## 5.2.5 Site Completion

1. Tighten the hex jam nut or locking nut on the CRL adjusting screw.
2. Replace the protective plastic cap on the pilot control valve (CRL item #3).
3. Tighten the hex jam nut or locking nut on the Speed Control (X42N-2 Strainer Needle Valve item #2).
4. Open station discharge isolation valve.
5. Open any previously isolated filtration systems or pressure tank isolation valves.
6. Enable pumps as desired and return station to automatic operation.

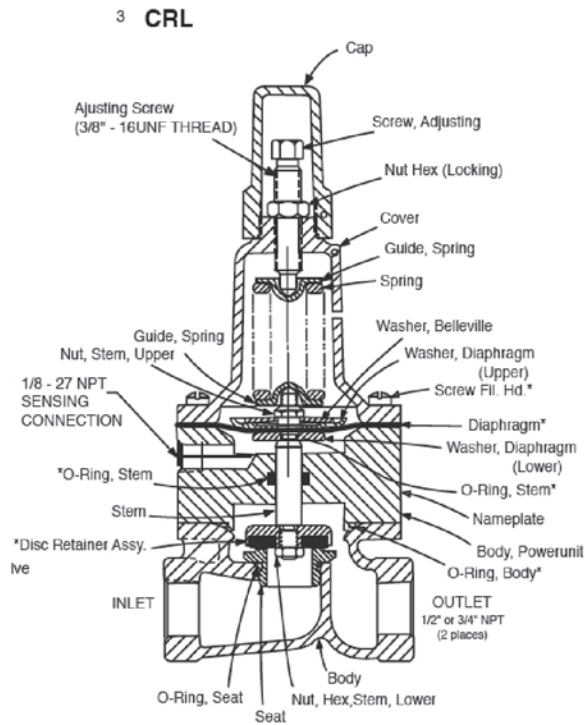
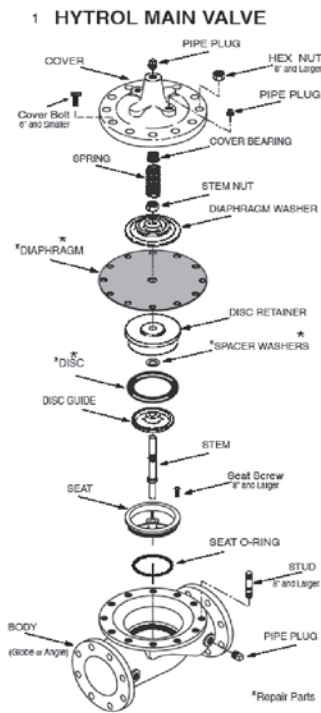

CLA-VAL Copyright Cla-Val 2007 Printed in USA  
 Specifications subject to change without notice.  
 P.O. Box 1325 • Newport Beach, CA 92659-0325  
 Phone: 949-722-4800 • Fax: 949-548-5441  
 E-mail: claval@cla-val.com • Website cla-val.com  
 © N-RK (R-5/07)

## 5.3 Powder Coating Touch-Up Procedure

The following steps are a general guideline to obtain excellent paint adhesion to your Rain Bird Pump Station powder coated plumbing and skid parts.

1. Identify if the area to be touched up is greasy or waxy. If so, wipe the part with solvent such as PPG DX330 Wax and Grease Remover, Sherwin Williams R7K156 Solvent Cleaner, or paint thinner to remove grease and lubricants from the manufacturing process. If area is relatively clean skip to step 4.
2. Scrub all surfaces of the area with mild detergent in hot water. Rinse well and wipe dry with a clean dry cloth.
3. Wipe the part again with solvent as in step 2 above. The surface must be absolutely clean before sanding to prevent the sanding process from spreading the contaminants or imbedding them into the surface.
4. Wire-brush any loose material such as scaled rust or dirt from area. Scuff sand all areas to be painted using progressively finer grit to about 150 grit paper. Do not try to completely remove or sand through the powder coating, but the complete paint area must be thoroughly sanded for the best paint adhesion results.
5. Wash and rinse away all sanding residue. If available, use compressed air to blow the rinse water out of all seams and dry the area with a clean towel. If the rinse water beads up anywhere on the surface, it is not clean and the solvent wipe and water washing steps must be repeated and additional sanding may be required in that area.
6. Wipe with solvent such as PPG DX330, Sherwin Williams R7K158, or paint thinner to remove any traces of contaminants or sanding residue. Wipe the surface dry with a clean cloth.
7. The area should now be ready for painting. If area is still heavily rusted, Rain Bird recommends a rusty metal primer such as Rust-Oleum Rusty Metal Primer, Rust Destroyer by Advanced Protective Products, Inc., or similar rusty metal priming product. Apply the primer according to the manufacturer's instructions for the product you are using. The recommended drying time between coats is especially important. A quick wipe with a tack rag right before priming helps remove any remaining dust.
8. After step (6) (or step (7) if required and fully cured) the area should be ready for a final protective coating. Rain Bird recommends a Direct-To-Metal (DTM) oil based industrial enamel paint such as Rust-Oleum Protective Enamel, Sherwin-Williams Industrial Enamel 100, or equivalent. Apply the enamel according to the manufacturer's instructions for the product you are using. The recommended drying time between coats is especially important. A quick wipe with a tack rag right before painting helps remove any remaining dust.

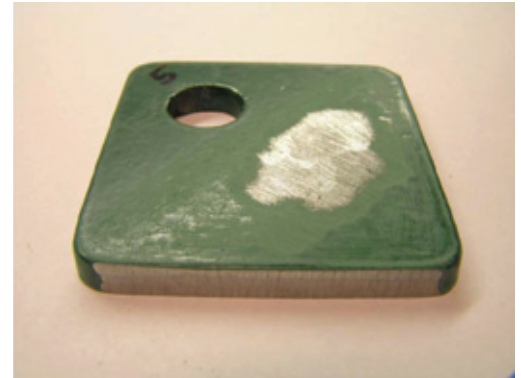

9. Follow these helpful hints for a successful paint job.
  - a. Be sure to use fresh paint products that are top quality from a reputable manufacturer. Do not try to economize by using inferior or leftover paint materials.
  - b. Select all the products for a paint job from a single manufacturer and do not mix different systems within a brand of paint. Use only products that are intended to be used together.
  - c. Make sure to thoroughly mix primer and paint before application.
  - d. Do not apply paint in either freezing or wet conditions. High humidity or low temperatures may lengthen drying time.
  - e. Oil based paint cleans up with mineral spirits or paint thinner.
  - f. Multiple coats of enamel finish will offer greater protection and lift to the affected area. Follow manufacturer recommendations for drying and recoating times.
  - g. Wear clean latex or nitrile gloves to prevent fingerprint oils from contaminating the surfaces of your cleaned parts. This also prevents your hands from getting full of paint.
  - h. Plan to prime the parts immediately after cleaning and sanding to prevent any bare steel areas from developing surface rust or the parts from becoming contaminated again.
  - i. Obtain a technical data sheet for each product being used and read and follow the instructions. The manufacturer's data sheet will provide specific instructions that apply to the product being used. These are available on-line or from your paint supplier.
  - j. Fumes from oil based paint contain petroleum distillates. Use only with adequate ventilation. Keep away from heat and flame. If spraying, use an appropriate respirator such as 3M Half Mask Organic Cartridge Breathing Respirator or equivalent.

### 5.3.1 Color Match Information

#### 1. Green

1 Quart Eddie Behr Premium Plus EXT Semi Gloss Deep Base (5340)				
AX	PERM YELLOW	0	22	1
D	THALO GREEN	1	39	1
KX	WHITE	0	11	0
R	EXTERIOR RE	0	22	1



#### 2. Blue - Rust-Oleum Gloss Protective Enamel. 7724 Sail Blue

#### 3. Grey – Sherwin-Williams CO F77XXA4101-7724, ANSI-61 Gray, #84034 B-LINE





## 5.4 Winterization Procedures

As colder weather moves in, now is the time to think about winterization of your pump station. Lack of proper winterization can be a costly oversight. Pump stations installed in areas where the temperature can drop below 32 degrees Fahrenheit require winterization to avoid costly freeze damage and to assure a smooth start-up in the spring. For your convenience, attached is a copy of the winterization procedures from the Rain Bird Pump Station manual.

Here are some important procedures that need to be followed:

1. Rain Bird recommends that pump stations be winterized prior to the rest of the irrigation system to minimize the potential for water to enter the system.
2. If you anticipate conditions where the exterior air temperature will drop below 32°F, the pressure transducer should be completely removed and placed in a sheltered environment for storage.
3. The water should be completely drained and blown out from the electronic enclosure's heat exchanger. Details of this procedure are provided in your manual.
4. For locations where freezing conditions are a common occurrence, the entire pump station should be winterized for the season.
5. Vents, open areas around inlet/discharge piping, and obvious gaps should be properly sealed to prevent the outside elements from entering the enclosure/cabinet.
6. An enclosure heater may have been provided with your pump station to provide additional heat during low temperature conditions. Due to varying environments and climate uncertainties, Rain Bird recommends that the pump station be winterized during periods below freezing. Please note that in the event of a power interruption, your heater will not be operational.

Questions about any of the procedures for winterization should be directed to the Rain Bird GSP team at 1-866-GSP-XPRT (1-866-477-9778).

Please be aware that damage caused by improper or incomplete pump station winterization is not covered under Rain Bird's Customer Satisfaction Policy. If you are interested in having a Rain Bird Authorized Service Provider complete your winterization please call the Rain Bird Services Corporation at (888) 444-5756 for your free estimate. Preventative maintenance and extended warranty options are also available.

We thank you for your business and for choosing Rain Bird as your Pump Station supplier.



### 5.4.1 Initial Conditions and Precautions

1. The Pump Station was started in accordance with Pump Station Start-Up Procedure and is running normally.
2. Only qualified personnel shall winterize the Pump Station. Personnel are considered sufficiently qualified for the assignment when they have;
  - a. Received training and had supervised experience on the task.
  - b. Understand the safety regulations, detailed function descriptions, and operational instructions, as well as manuals for the machine/equipment assignment.
3. Prior to shutting down the Pump Station, ensure that no unauthorized personnel are in the vicinity of the pumps, electrical switchgear, or other potentially hazardous areas.
4. The electrical cabinet installed on the pump station has an interlock that switches electrical power OFF when the cabinet door is opened.

**WARNING:** DO NOT OVER-RIDE THIS INTERLOCK. Death or serious injury due to electrical shock can occur.

5. Never hang or store items on pump station piping or components.
6. Ensure compliance with all applicable local, state, and OSHA regulations when installing, operating, repairing, or maintaining the Pump Station.

### 5.4.2 Winter Shut-Down Procedure

The intent of this procedure is to prevent damage to the pump station that may occur when the ambient temperature drops < 32°F, causing the water inside the pump station to freeze. When water freezes, it expands. This expansion can result in catastrophic damage to critical components on the pump station. This phenomenon can occur regardless of the presence of an enclosure heater or the purchase of an Environmental Package.

The concept of this procedure is to remove liquid water, to the furthest extent possible, from pump station internals and hence prevent damage due to freeze expansion. Any portion of the pump station (whether or not it is directly considered in this procedure) where the service provider judges liquid water may result in freeze expansion damage should be drained.

1. Heat Exchanger (Figure 1)
  - a. With the Pump Station running, shut the isolation valve for the heat exchanger supply line and disconnect the supply line from the heat exchanger. (With the Pump Station running, the VFD is on. When the VFD is on, power is supplied to the heat exchanger's solenoid operated supply valve, opening the valve.)
  - b. Using compressed air, blow out any remaining water in the heat exchanger by applying compressed air to the supply pipe on the heat exchanger. Water remaining inside the heat exchanger will be flushed to the system.
  - c. Disconnect the return line from the heat exchanger. Apply compressed air once again to the heat exchanger supply inlet to ensure any remaining water is removed.
  - d. Shut down the Pump Station per OP2.1 and reconnect lines.

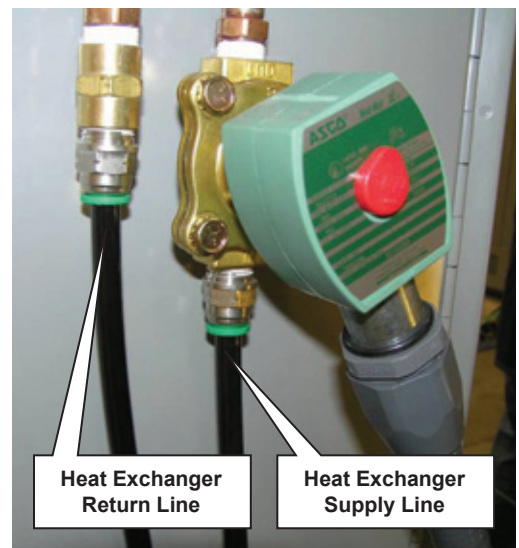

## 2. Filters

- a. Rain Bird Back Washing Screen Filters (Figure 2).
- b. After the last irrigation cycle of the season run a back-flush cycle two (2) times.
- c. Drain the system completely (ensure all lines are completely drained). Use compressed air to remove remaining water from lines and components. Once it has been verified that all remaining water has been removed, reconnect lines.
- d. Loosen the fasteners on the 3-Way Solenoid Hydraulic Actuator flanges to allow water to exit the valve. Use compressed air to ensure any remaining water is removed.

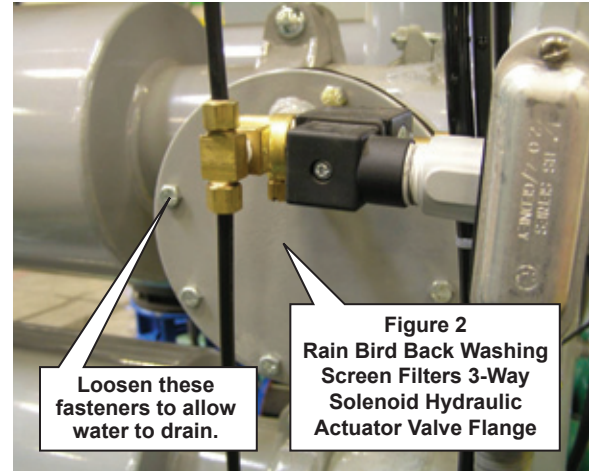

**CAUTION:** System must be drained completely prior to loosening the fasteners.

- e. Remove the wedge-wire cartridges and pressure wash thoroughly. Either replace the cartridges or keep them stored in a secure place.
- ## 3. Amiad Filters. The following directions are provided to prepare AMIAD filters for extended periods of non-operation under freezing conditions. Only experienced personnel should attempt this procedure. If you have any questions or require any additional information, please contact Rain Bird.
- a. Clean the screen element by one of the two methods:
    1. Prior to pump station shutdown, initiate three (3) manual power-flush cycles by using the Touch Screen controls.
    2. Removing the screen element to wash it with a high-pressure washer to remove debris. The screen element has to be inspected visually by looking through it into a source of light to verify its complete cleanliness.
- NOTE:** Any residual contamination could dry and adhere onto the screen, preventing the passage of water during future use. Reassemble screen into the drained filter.
- b. Drain the filter body completely to prevent damage to its components.
  - c. Center the limit switch contactor plate between the limit switches using the running/stop button on the Touch Screen that will stop the filter cycle. Do a manual start and then press the stop button before the limit switch disc reaches the switch (on EBS and SAF models).
  - d. Disassemble the 3/4" control filter, clean, drain the feed tubing and reassemble.
  - e. Disconnect and drain the water from the pressure differential switch feed tubes (EBS, SAF, ABF, AEF models only). Reconnect the feed tubes.
  - f. If the filter is located outdoors, cover the drive unit (motor/gear) assembly with a suitable material (plastic tarp) to prevent introduction of moisture during periods of non-operation.
  - g. If your filter is hydraulically operated (models AHF, SHF, TAF), disconnect and drain the feed tubes to the hydraulic turbine/actuator, pressure differential switch/pressostat and hydraulic valves. Turn the rotation indicator (AHF model only) back and forth to drain the actuator. Reconnect the feed tubing.
  - h. Disassemble and clear the water from all solenoid valves. Use compressed air to remove any remaining water and then reassemble the valve.



## 4. WYE Strainers

- a. Remove the WYE strainer screen and clean it.
- b. Remove any water from the WYE strainer solenoid valve. Ensure water is removed from the top and bottom of the diaphragm.

**NOTE:** The WYE strainer solenoid valve can also be removed from the pump station for winter lay-up, after the pump station is shutdown. If electing to remove the valve, install covers over system openings and store the valve in a location with a temperature > 32F. Following winter shutdown, be sure to reinstall the valve prior to starting the system.

- c. Reposition the WYE strainer ball valve to half open.
- d. Drain any remaining water from the drain pipe.

## 5. WYE Strainers < 1". Remove and clean all WYE strainers. Remove any excess material using compressed air and then reinstall all WYE strainers after verifying that it is clear of all debris.

## 6. Pump Station Pipes and Manifolds (Figures 3 and 4)

- a. With the Pump Station shutdown, connect hoses to all drain connections on pipes and manifolds. Direct hoses to a safe location and then open all drain connection valves.
- b. Remove all drain plugs from pipes and manifolds.
- c. Position all valves to an intermediate position (neither completely shut nor completely open).



Figure 4  
Example Pump  
Station Drain Plug

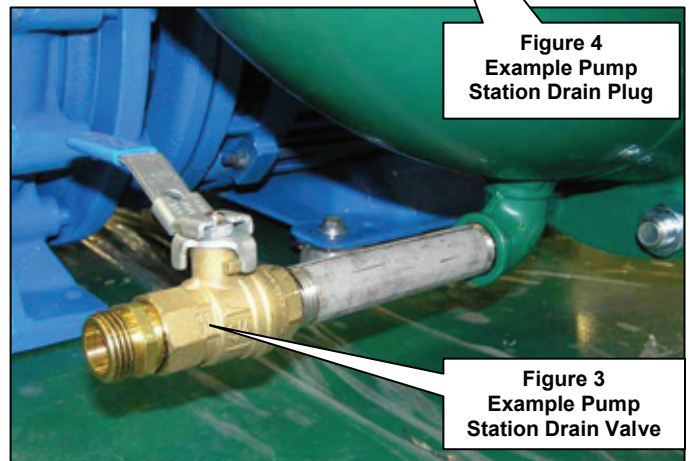
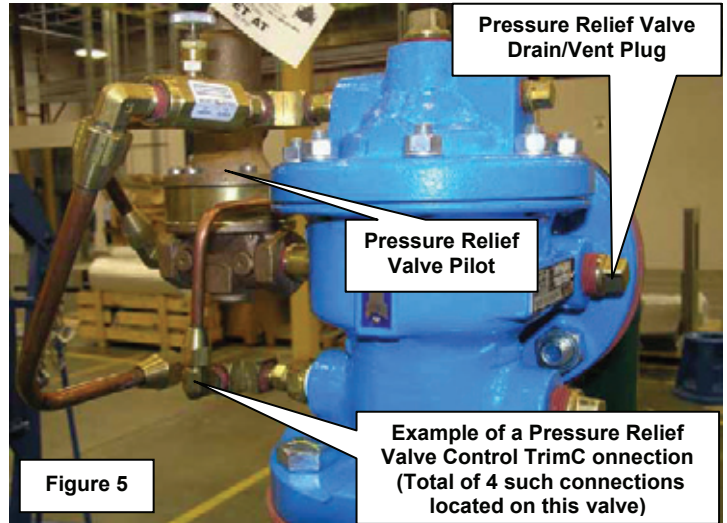

Figure 3  
Example Pump  
Station Drain Valve

7. Pressure Relief Valves (Figures 5) All liquid water must be removed from the pressure relief valve. The pressure relief valve is a critical component that could suffer serious damage from freezing water expansion. In lieu of performing the following procedure, the pressure relief valve can be removed from the system entirely, with blanks installed to cover the opening piping. When electing to remove the pressure relief valve from the system, ensure that it is stored at a temperature > 32°F while the Pump Station is in winter lay-up.

- a. With the Pump Station shutdown, remove all vent plugs from pressure relief valves and loosen all control trim connections sufficiently enough to allow water to leak out. Remove and clean all WYE strainers located on the pressure relief valve.
- b. Using compressed air, blow out any remaining water from the pressure relief valve. If the service provider suspects that any water is remaining in the pressure relief valve, a shop vacuum may be utilized to remove the remaining liquid.
- c. Disassemble Pressure Relief Valve Pilot, remove all remaining water, and then reassemble.



8. Centrifugal Pumps (Figure 6). With the Pump Station shutdown, open the drain fitting located in vicinity of pump impeller housing. This will allow water to drain from the pump. When water is finished draining, reinstall fitting.

9. Multi-staged Canned Pumps (Figure 7). With the Pump Station shutdown, open the drain fitting located near the base of the pump. This will allow water to drain from the pump. When water is finished draining, reinstall fitting.

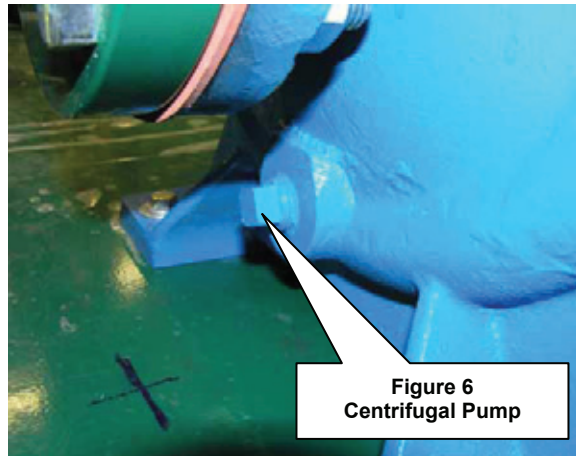
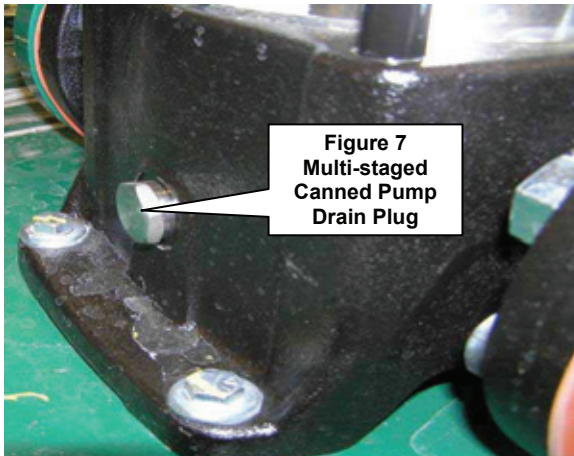

## 10. Submersible Pumps.

- a. Small submersible pumps should be pulled out of the water and stored indoors. Drain the pump completely and cover the ends to prevent debris and animals from entering it.
- b. Large Submersible pumps should be winterized using the following procedure; A check valve is located on the output side of the submersible pump that will trap water inside the pump assembly even after the level of the sump is drained below the level of the submersible pump suction. This water can result in freeze expansion damage to the pump. If the sump level is less than pump suction on the submersible pump, the water remaining inside the submersible pump can be removed in the following manner:
  1. With the Pump Station shutdown, disconnect and remove the groove fitting and check valve on the discharge side on the submersible pump.
  2. Using a shop vacuum or similar device, vacuum the remaining water from inside the submersible pump by running the vacuum line down to the pump via the open flange. This process can be facilitated by fabricating a connection between the vacuum hose and a 0.5" I.D. poly hose. Use a length of hose long enough to ensure all water remaining inside the submersible pump can be successfully removed.

## 11. Vertical Turbine Pumps

- a. Fill the pump motor to maximum reservoir capacity with Chevron GST® Oil ISO 32.

**CAUTION:** Only fill the motor with oil to the maximum level indicated on the sight glass. Overfilling will cause catastrophic damage to the motor internals. (When coming out of winter lay-up with the intention of restoring the pump station to normal operation, drain oil from the pump motor until the minimum level as indicated in the sight glass).

- b. Gauge and Pressure Sensing Lines, Pressure Transducers (Figure 8).
  - i. Disconnect and drain all gauge and pressure sensing lines. Blow out lines with compressed air as necessary.
  - ii. The pressure transducer must be removed and stored in a location >32°F for the duration of the winter shutdown. After removal, holes should be plugged. Following winter shutdown, be sure to reinstall the transducer prior to starting the system.

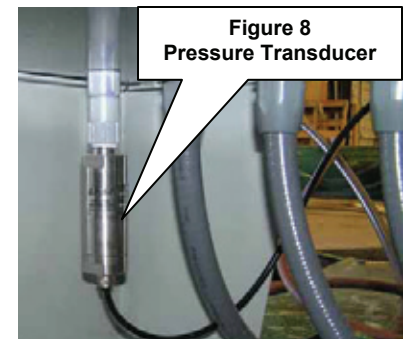

**NOTE:** Push-to-Connect fittings are removed by pushing up on the collar and pulling down to release the other side of the fitting.

12. Once it has been verified all water has been satisfactorily removed from the system, reinstall all drain and vent plugs, and shut all drain valves. Reconnect all lines unless additional drainage is required. If a section of the pump station contains water that cannot be removed via a drain plug or drain valve, disassemble the appropriate section and remove the remaining water.

**CAUTION:** Failure to properly Winterize the Pump Station may result in catastrophic failure of components when temperatures drop below 32 degrees Fahrenheit at sea level. Elevation will affect the freezing point however it is negligible.



## **5.5 Global Service Plan (GSP) Support Instructions**

When service or additional troubleshooting is required, please contact Rain Bird Global Service Plan (RB GSP) at (866) GSP – XPRT or (866) 477 – 9778.

For best support, please be on site at the station with the ability to run irrigation. Also, collect and be prepared to discuss the following information:

1. 6 digit GSP Customer # for the Pump Station. Please do not confuse the Central Control System Customer #. (123456)
2. Pump Station Name as printed on the User Manual or Serial Number. This name should also be embossed on the skid near the Control Panel. The name of a site may change, however our records may not necessarily reflect such a change.
3. List of all Alarms present.
4. Time and date of the fault or anomaly.
5. Status of other installed equipment at the time of the fault or anomaly:
  - a. Where the filters in a cleaning cycle?
  - b. Was the PRV venting or leaking?
  - c. What is the status other control valves (Heat Exchanger, Self Cleaning Intake, etc.)
  - d. How many pumps were running?
6. Troubleshooting steps already accomplished.
7. Reproducibility of the fault or anomaly.
  - a. Is the fault intermittent or able to be reproduced?
  - b. What are the conditions required to reproduce the anomaly?
8. Status of the irrigation system at the time of the fault or anomaly (flow rate, pressure, on/off).
9. Status of communication between the Pump Station and Central Control (if installed)

Any additional information that can be provided will be helpful for problem resolution.

## 6.0 Basic Troubleshooting

The following section provides basic troubleshooting technique and procedures for a few common situations that may be encountered. The key concept in troubleshooting any issue is isolation. Remove or disable components until a problem can be reproduced or eliminated. Every Pump Station includes multiple isolation valves and Touch Screen parameters that are very useful when troubleshooting.

It is very important to identify the root cause of an issue by reproducing the fault or failure if possible. Intermittent faults are very difficult to analyze and may be temporarily masked by certain fixes but not completely resolved. Most faults on Pump Stations can be easily reproduced if the Operator fully understands the hydraulic design as well as the operation of each sensor, valve and device. The motivation here is to save the Owner/Operator's time and resources by preventing the replacement of perfectly good parts and components.

**WARNING:** Opening the interlocked Disconnect Switch on the Pump Station's Electric Control Panel does not de-energize the Panel as power is still applied to the source side of the Disconnect Switch. De-energize by opening the wall mounted service disconnect switch on the secondary side of the power transformer.

6.0	Basic Troubleshooting.....	41
6.0.1	In all cases the following should be accomplished first:.....	42
6.0.2	Parameter Adjustment Worksheet.....	43
6.1	Pump Start Process - Abnormal.....	45
6.2	Cycling of Main Pump(s).....	46
6.3	Failure to Shutdown - Main or PM Pump(s).....	47
6.4	PRV Troubleshooting.....	48
6.5	Phase Monitor Alarm.....	49
6.6	Phase Monitor Major Alarm.....	49
6.7	Low Flow / Sensor Alarm (Flow Meter Fault).....	50
6.8	Flow Sensor Fault, Major Alarm.....	51
6.9	Touch Screen Fails to Power On.....	51

### **6.0.1 In all cases the following should be accomplished first:**

1. Confirm Electrical, Mechanical and Hydraulic Performance
  - a. Ensure all circuit breakers are reset and operational.
  - b. Ensure discharge manifold maintains pressure when pumps are shutdown (off). This will assure proper operation of check valves and minimal system leakage.
  - c. Check PRV operation and reset flush pressure to 30-40PSI above discharge set pressure if necessary. This will ensure the PRV provides real safety without the nuisance of intermittent flushing or leaking during irrigation or troubleshooting.
2. Record Current Parameters. Use the attached spreadsheet to record all pertinent parameters and any additional parameters as necessary. This will set a baseline to return to in the event a change causes unintended responses or the parameters become corrupted.
3. Observe System Response with Existing Configuration.
  - a. Pressurize the Discharge Manifold / irrigation main line to the desired set point.
  - b. Run a standard flow zone normally conducted during irrigation. Monitor the pressure drop and take note of the pressure when the PM pump starts and when the first main pump starts.
  - c. Attempt to reproduce any reported abnormalities and note flow rate, pressure, VFD speed, number of pumps running and any additional hardware conditions at the time of the abnormality.
4. Create a Plan to Correct any Undesired Events or System Response.
  - a. Isolate the problem component or system to either only test the problem component, or test the system without the problem component.
  - b. Record the new parameters to change. Attempt to change only one parameter at a time and observe the new behavior before changing a second parameter to eliminate confusion.
5. Implement the Plan and Test the System / Station.



## 6.0.2 Parameter Adjustment Worksheet

Main Menu	Existing Parameter		New Parameter	
	1st	2nd	1st	2nd
Adjustments				
Pre-Set Pressure				
Preset Pressure:	psi		psi	
Reduce with ext signal:	psi		psi	
Reduction at 1 Pump:	psi		psi	
Reduction at 2 Pumps:	psi		psi	
Reduction at 3 Pumps:	psi		psi	
Reduction at 4 Pumps:	psi		psi	
Start & Stop Settings				
StartMargin Large Underpressure:	psi	sec	psi	sec
StartMargin Small Underpressure:	psi	sec	psi	sec
Delay Start 2nd Pump:		sec		sec
StopMargin Large Overpressure:	psi	sec	psi	sec
StopMargin Small Overpressure:	psi	sec	psi	sec
Adjustments PM Pump				
PM Pump Installed:				
On at Irrigation:				
PM Pump with VFD:				
StartMargin:	psi	sec	psi	sec
StopMargin:	psi	sec	psi	sec
Stop at Flow:	gpm		gpm	
Adjustments Flowmeter				
Flowmeter Installed				
Go to Irrigation at:	gpm		gpm	
Stop Irrigation at:	gpm		gpm	
Stop Delay:	sec		sec	
Adjustments Soft Start				
Soft Start Activated:				
Low Pressure when Soft Start On:	psi		psi	
Delay Pressure Rise:	sec		sec	
Settings Direct Start				
Start without VFD:				



Main Menu	Existing Parameter		New Parameter	
	1st	2nd	1st	2nd
Adjustments				
Auto-Backwashing Filter				
Number of Filter Elements:				
Type:				
Backwash time per element:	sec		sec	
Time between Back Washes:	hrs		hrs	
First Flush Time:	hrs		hrs	
Second Flush Time:	hrs		hrs	
Enabled/Disabled:				
Service-Menu 1				
Stop Without Flow meter				
VFD #1 Stop Limit:	%	sec	%	sec
VFD #2 Stop Limit:	%	sec	%	sec
VFD #3 Stop Limit:	%	sec	%	sec
Service-Menu 2				
Alarm High & Low Pressure				
Alarm Limit: (high)	psi	sec	psi	sec
Alarm Margin Low Pressure:	psi		psi	
Delay without Soft Start:	min		min	
Delay with Soft Start:	min		min	
Alarm, High Flow				
Enabled:				
Flow Pump:	gpm	min	gpm	min

## 6.1 Pump Start Process - Abnormal

The pump(s) are not starting when they should or starting when not irrigating thus causing abnormal pressure fluctuations and/or alarms. Pumps may not start at all or they may be starting late after significant pressure drop from an open valve.

### 6.1.1 Theory of Operation:

On stations with multiple pumps, the start sequence should be the PM Pump then the Main pump(s) followed by the Jockey or Intermediate Pump. Depending on the parameters, if the pressure drop or flow rate is significant the PM should be bypassed and the Intermediate or Main pump will start first. Stations with a single pump will automatically activate periodically to maintain mainline pressure due to small system leaks.

When the pumps are off, the PLC will continuously monitor the discharge pressure and compare it with the Preset Pressure. The difference is then compared to the PM/Jockey Start Margin parameter as well as the main pump Start Margin Large Under Pressure and Start Margin Small Under Pressure parameters. When the pressure difference is greater than the Start Margin for the specified amount of time, the respective pump will start.

### 6.1.2 Troubleshooting:

1. Pumps do not start at all.
  - a. Check the Pump Status Button(s) for proper indication. Enable each pump as required if the status color is gray.
  - b. Troubleshoot and then clear any active alarms.
  - c. Check motor circuit breakers and motor protecting devices. (Power off, then open Control Panel to reset breakers).
  - d. Check 3 phase and 1 phase surge arrestors for green indications on each leg.
2. Pump(s) do not start in a timely manner causing the discharge pressure to drop significantly.
  - a. Decrease the PM Pump Start Margin parameters to react to smaller under pressure conditions. Reduce the pressure margin and/or under pressure duration. Standard settings are 3PSI for 2 seconds.
  - b. Decrease the main pump Start Margin Large and/or Small Under Pressure Parameters. Test to ensure the main pumps start only during irrigation and not during a PM event.
3. Main Pump(s) start when not irrigating.
  - a. Check the irrigation system and Discharge Manifold for large leaks.
  - b. Check for premature PRV flushing and/or continuous leaking.
  - c. Check any automatic filtration systems for continuous flushing.
  - d. Decrease the PM Pump Start Margin parameters to react to smaller under pressure conditions. Reduce the pressure margin and/or under pressure duration. Standard settings are 3PSI for 2 seconds.
  - e. Increase the main pump Start Margin Under Pressure parameters to prevent the main pumps from starting during a pressure maintenance event. The Small Under Pressure parameter should have a relatively small pressure difference for a relatively long duration, where the Large Under Pressure parameter should have a large pressure margin but very short duration.
  - f. Check the condition of individual pump check valves.

## 6.2 Cycling of Main Pump(s)

Main Pump(s) repeatedly cycle on and off during stabilized irrigation resulting in large pressure swings and erratic operation.

### 6.2.1 Theory of Operation:

The pumps will only start based on under pressure conditions. They will shutdown for the following reasons: over pressure, low VFD speed, Stop Irrigation Flow Rate or certain alarm conditions. If the over/under pressure envelope is significantly tight, the main pumps will short cycle. When the first Main Pump (powered by the VFD) is at 100% speed and pressure continues to drop, the second Main Pump will start DOL at 100% while the VFD controlled pump will slow to the Minimum Start Speed normally 50%. If the Delay Start 2<sup>nd</sup> Pump parameter is too small, the pumps may short cycle.

### 6.2.2 Troubleshooting:

1. Confirm Electrical, Mechanical and Hydraulic Performance.
  - a. Check and reset Circuit Breakers as necessary.
  - b. Check irrigation system for leaks.
  - c. Check the Pump Station for leaks and proper operation: PRV, Check Vales, Automatic Filtration and other Solenoid Control Valves.
2. Review Start and Stop Parameters.
  - a. Check Start Margin Under Pressure parameters and Stop Margin Over Pressure parameters to ensure a sufficient performance envelope and time frame.
    1. The pressure range above and below the Preset Pressure should be much tighter for very small commercial irrigation systems than large Golf Courses with enormous volume. The Stop Margin Small Over Pressure is usually very small as the pumps rarely create more pressure than required. This is due to the immediate response to a valve throughout small systems.
    2. Increase parameter durations to overcome systems with transient pressure spikes.
  - b. Review the Delay Start 2<sup>nd</sup> Pump and increase as necessary for the first main pump to stabilize before starting the second. This is normally 2 seconds or more.
3. Review Stop on Flow if a Flow Meter is installed or Stop on VFD speed parameters.
  - a. The flow rate must exceed the stop on flow parameter then drop below for the specified time to shutdown. Decrease the stop flow rate .
  - b. Compare the stabilized VFD speed while irrigating the smallest flow zone with the Stop without Flow Meter VFD speed parameter. Adjust the stop speed to 5% below the stabilized low flow zone VFD speed.
4. Compare the irrigation scheduled flow rate with pump curves.
  - a. If the scheduled flow rate is less than or near the minimum recommended flow rate or the Minimum Continuous Stable Flow rate (MCSF), adjust the irrigation schedule to demand higher flow rates closer to the pump(s) BEP.
  - b. If the initial scheduled flow rate is at or above the BEP of the main pump, reduce the initial demand to about 25% of the BEP. Then increase to 50%, then 100%. This will reduce the initial shock and create a more stable response.

### 6.3 Failure to Shutdown - Main or PM Pump(s)

A pump fails to shutdown after an irrigation cycle or Pressure Maintenance (PM) event and runs at minimum speed continuously.

#### 6.3.1 Theory of Operation:

The pumps will shutdown for the following reasons: over pressure, low VFD speed, Stop Irrigation At Flow Rate or certain alarm conditions. Typically the station will not over pressure to shutdown as the PLC regulates pressure exceptionally well. Therefore the station should rely on the Flow Meter to shutdown properly. In some cases, the Stop without Flow Meter VFD Speed is used when a Flow Meter is not available, however this is not recommended. If the station exhibits multiple shutdown failures installing a pulse type Flow Meter will remedy this situation.

**NOTE:** In order for the pumps to shutdown on flow, the actual displayed flow rate must exceed and then drop below the Stop parameter for the specified duration.

#### 6.3.2 Troubleshooting Flow Meter Installed:

1. Pressure Maintenance (PM) Pump fails to shutdown.
  - a. Observe a PM cycle and take note of the maximum flow rate generated.
  - b. Decrease the Stop at Flow parameter below the maximum PM flow rate which may be less than 15GPM for small systems.
  - c. Decrease the Stop Margin Over Pressure parameters.
2. Main Pump fails to shutdown after a PM event. (PM not installed)
  - a. Observe a PM cycle and take note of the maximum flow rate generated.
  - b. Increase the Go to Irrigation At parameter above the maximum PM flow rate.
  - c. Decrease the Stop Irrigation At parameter below the maximum PM flow rate.
  - d. Decrease the Stop Margin Small Over Pressure parameters to minimum values.
  - e. Increase the Start Margin Small Over Pressure parameters to require more of a pressure drop to start the Main Pump.
3. Main Pump fails to shutdown after irrigation.
  - a. Review the pump curve.
  - b. Decrease the Stop Irrigation At parameter to the MCSF or less.
  - c. Increase the Go to Irrigation At parameter.
  - d. Decrease the Stop Margin Small Over Pressure parameters.
  - e. Adjust the irrigation schedule to reduce demand more rapidly.

#### 6.3.3 Troubleshooting Flow Meter Not Installed:

1. Decrease the STOP MARGIN SMALL OVER PRESSURE parameters to minimum values. Then adjust as necessary to prevent short cycling.
2. Open the smallest flow zone normally run during irrigation. Once the system stabilizes, take note of the VFD speed.
3. Adjust the Stop without Flow Meter VFD Speed to this speed.
4. Ensure the duration is significantly large (30seconds +/-) to provide sufficient buffer when irrigating this small zone.

## 6.4 PRV Troubleshooting

Symptom	Probable Cause	Remedy
Valve oscillation (chattering)	Air above diaphragm	Loosen pipe plug on top cover to vent air, retighten when only water leaks out.
	Dirty wye strainer	Flush strainer
Main valve fails to open	Inlet pressure below setting of pilot valve	Perform above procedure
	Pilot valve stuck closed, mineral deposit or foreign material between disc retainer and power unit body.	Disassemble control valve and clean
	Pilot valve diaphragm ruptured or diaphragm nut loose. Water coming out of the vent hole in cover.	Disassemble and replace diaphragm, Tighten Nut.
	Main valve stuck closed.	Disassemble main valve and clean
Main valve fails to close	Mineral buildup on stem/ stem damaged	Replace damaged parts, check downstream cover and CK2 isolation valves are open
	Inlet pressure above setting of pilot valve	Perform above procedure
	Clogged needle valve or strainer	Disassemble and clean
	Pilot valve stuck open. Mineral deposit or debris under disc retainer or under diaphragm assembly	Disassemble and clean
	Main valve stuck open. Mineral buildup on stem. Debris between seat and disc assembly.	Disassemble and clean
Valve leaks continuously	Main valve diaphragm worn	Disassemble and replace valve
	Pilot valve disc worn out	Disassemble and replace
	Main valve disc worn or small pin hole in main valve diaphragm	Disassemble and replace
	Set point too close to inlet pressure	Perform above procedure

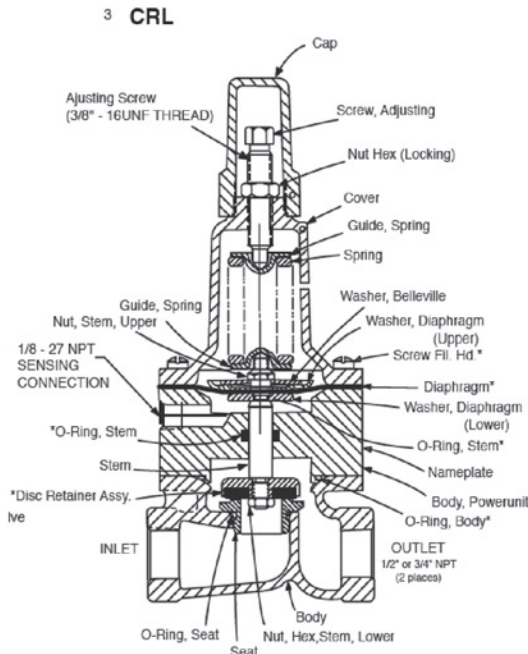
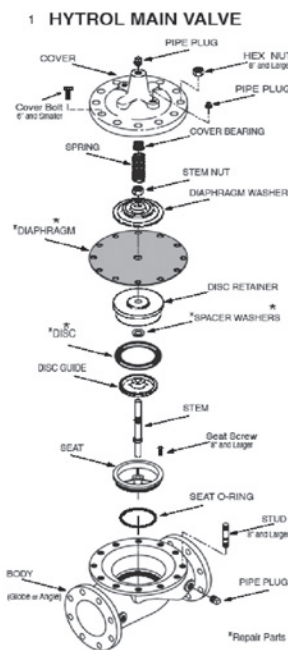

CLA-VAL Copyright Cla-Val 2007 Printed in USA  
 Specifications subject to change without notice.  
 P.O. Box 1325 • Newport Beach, CA 92659-0325  
 Phone: 949-722-4800 • Fax: 949-548-5441  
 E-mail: claval@cla-val.com • Website cla-val.com  
 © N-RK (R-5/07)

## **6.5 Phase Monitor Alarm**

The Phase Monitor Alarm temporarily disables the Pump Station and is manually or automatically reset. When the alarm is active the following will occur:

1. Temporarily disables pumps.
2. Activates the Alarm Relay Output if Power Failure Alarm Relay is enabled.
3. Activates Soft Alarm to PC if enabled.
4. Activates Hard Alarm to PC if enabled.

### **6.5.1 Required Conditions:**

The Phase Monitor Alarm is activated when the phase sensor detects a loss of phase. The alarm will reset itself when the condition is cleared or when the Reset Button is held for 2.5 seconds.

### **6.5.2 Troubleshooting:**

1. Confirm incoming 3 Phase power failure.
2. Check status and operation of 3 Phase surge arrestor. All three (3) LED's should be illuminated green.
3. Power down and restart Station.

## **6.6 Phase Monitor Major Alarm**

The Phase Monitor Major Alarm bit disables the Pump Station and requires personnel action to reset. When active the following will occur:

1. Inhibits 3 Phase Monitor Alarm bit.
2. Activates the Alarm Relay Output if Power Failure Alarm Relay is enabled.
3. Activates the Soft Alarm to PC if enabled.
4. Activates the Hard Alarm to PC if enabled.

### **6.6.1 Required Conditions:**

The Phase Monitor Alarm bit is activated when the number of 3 Phase faults exceeds the maximum allowed limit set in the Touch Screen. The alarm requires the user to reset at the Touch Screen by holding the reset for 2.5 seconds.

### **6.6.2 Troubleshooting:**

1. Confirm incoming 3 Phase power failure.
2. Check status and operation of 3 Phase sensor.
3. Check sensor wiring and control wire to the PLC.
4. Power down and restart Station

## 6.7 Low Flow / Sensor Alarm (Flow Meter Fault)

The Low Flow / Sensor Alarm bit temporarily shuts down the Pump Station and is automatically or manually reset. When active the following will occur:

1. Activates the Alarm Relay if Flow Meter to Alarm Relay enabled.
2. Activates the Soft Alarm to PC if enabled.
3. Activates the Hard Alarm to PC if enabled.

### 6.7.1 Required Conditions:

A Flow Meter is installed the displayed flow rate is less than expected for more than 40 seconds. The alarm will activate unless a major alarm is already present. The alarm will reset automatically upon a user specified delay.

1. Flow Meter 1 is installed.
2. Flow Meter Major Alarm is Off.

### 6.7.2 Troubleshooting:

1. Verify status of all circuit breakers in electric panel. A tripped motor breaker may be the root cause of the alarm as some breakers are not monitored by the PLC.
2. Check the PRV and/or filtration system if installed. Significant flow from the manifold prior to the Flow Meter will also cause this alarm. A leaky solenoid control valve may force the PRV or filter to flush continuously.
3. Verify the Flow Meter operates properly.
  - a. Ensure the sensor will read and display flow on the Touch Screen.
  - b. Verify parallel alignment of the sensor with the flow meter spool pipe.
  - c. Verify proper insertion depth of the sensor (if able).
  - d. Ensure the impellers are not clogged or blocked with debris (if able).
  - e. Check sensor signal wire path. Ensure the signal wire does not cross high voltage power lines on the station's skid.
4. Verify all check valves seal properly.
5. Isolate other system components as necessary.
6. Contact Rain Bird GSP.



## **6.8 Flow Sensor Fault, Major Alarm**

The Flow Sensor Fault, Major Alarm bit activates after multiple Flow Sensor Fault occurrences and requires personnel action as the alarm disables the Pump Station. When active the following will occur:

1. Activates the Alarm Relay if Flow Meter to Alarm Relay is enabled.
2. Activates the Soft Alarm to PC if enabled.
3. Activates the Hard Alarm to PC if enabled.

### **6.8.1 Required Conditions:**

A Flow Meter Major Alarm activates when the number of Flow Sensor Fault Resets is equal to or greater than the maximum allowed per 8 hours.

### **6.8.2 Troubleshooting:**

1. Perform troubleshooting steps above for Low Flow / Sensor Alarm (Flow Meter Fault).
2. Replace and/or service parts.
  - a. Circuit breakers if continuous tripping.
  - b. PRV Diaphragm, pilot valve or wye strainer if continuous flushing.
  - c. Filter control valve.
  - d. Motors if necessary based on motor health tests.
  - e. Flow Meter Signal Wire.
  - f. Flow Meter.
  - g. Check Valves if necessary.
  - h. VFD's if necessary.

## **6.9 Touch Screen Fails to Power On**

The E1071 Touch Screen is powered by 24VDC+. The 24VDC is provided by a dedicated power supply connected to 120VAC.

### **6.9.1 Troubleshooting:**

1. If the screen does not receive the proper voltage or if the ground is faulty, the blue LED on the E1071 may flash. If this occurs call Rain Bird GSP and refer to the GSP Support Instructions.
2. If no indication on the Touch Screen is present with the Main Disconnect Switch in the ON position, check the red E-Stop button on the front panel. Release it by rotating the button until it pops out.
3. Check all Circuit Breakers within the Control Panel. (Power OFF)
4. Contact Rain Bird GSP.

THIS PAGE INTENTIONALLY LEFT BLANK

## **Appendix – A: Pump Curves**

THIS PAGE INTENTIONALLY LEFT BLANK

## **Appendix – B: Approval Drawing**

THIS PAGE INTENTIONALLY LEFT BLANK

## **Appendix – C: Electrical Schematic**



THIS PAGE INTENTIONALLY LEFT BLANK

## **Appendix – D: Installation Instructions**

## Installation Guidance and Instructions

### Initial Conditions and Precautions

- The Pump Station shall only be installed on a concrete slab rated for the weight of the Pump Station.
- Only qualified personnel shall perform the Pump Station installation. Personnel are considered sufficiently qualified for the assignment when they have 1) received training and had supervised experience on the task at hand; and 2) understand the safety regulations, detailed function descriptions, and operational instructions, as well as manuals for the machine/equipment assignment.
- The installation location shall be clear so as to allow crane access. The installation should be halted if interference between the crane and overhead obstructions is anticipated.
- The ground selected for crane operations shall be of the necessary integrity to safely support crane operations.
- The Pump Station shall be lifted with proper lifting equipment (i.e. fork lift or crane). Be sure all necessary lifting equipment is used properly. Lifting points are located on the base of the Pump Station. Spreader bars may be required for proper lifting.
- DO NOT USE FITTINGS LOCATED ON TOP OF ELECTRICAL CABINETS FOR LIFTING THE PUMP STATION. These fittings are for maneuvering the electrical cabinet only, and will not support the overall weight of the pump station.
- The Pump Station must be installed according to the applicable wiring diagram.
- Verify Vertical Hollow Shaft Motors have been filled with oil prior to connecting electrical power to the motors.
- Ensure compliance with all applicable local, state, and OSHA regulations when installing, operating, repairing, or maintaining the Pump Station.
- The Pump Station is manufactured to best ensure operator safety under normal operating conditions. The manufacturer will not take any responsibility for personal or equipment damage if the equipment has been modified or if the safeguards have been modified in/by a non-authorized way/technician. Any proposed modifications must be carefully documented (to include a risk analysis) by the party proposing the modification; and coordinated with and approved by the manufacturer. Otherwise, the customer assumes all responsibility for its actions and subsequent consequences.

### Installation Procedure

- 1) Position the skid in final location. Center the pump station over the well using the welding marks located on the pump station base. Install the electrical cabinet with power in the OFF position (according to attached wiring diagram) if it is delivered separately. Attach pump skid to floor using clamping dogs that engage the channel flange on the perimeter of the skid. Clamping dogs should be bolted to concrete floor.

**NOTE:** STEPS 2), 3), 4), 5), 6), 7), 9), AND 12) APPLY TO VERTICAL TURBINE PUMP STATIONS ONLY

- 2) With power OFF and in this order, install base gaskets, install groove fitting gaskets, insert vertical turbine pumps in the designated order (P1, P2, P3 etc), install plumbing (check valves, butterfly valves, and Victaulic fittings), secure pumps with fasteners, and install vertical turbine motors. Ensure that the base of the vertical turbine motor sits inline with the surface on top of the vertical turbine pump. Secure the base of the vertical turbine motor to the top of the vertical turbine pump. If assembly of the vertical turbine pump is required, perform step and then insert vertical turbine pumps in the designated order.

### 3) Vertical Turbine Pump Shaft Assembly:

- a) Perform this step only if the length of the vertical turbine pump exceeds shipping allowances, the vertical turbine pump will be disassembled prior to shipping and will require assembly in the field. Use the following procedure to disassemble prior to shipping, and assemble the vertical turbine pump in the field.
  - i) Liberally coat all threads (shaft housing and shaft) with Loctite C5-A, Molykote P37, or Never-seez.
  - ii) Install bearings taper side down. iii) When using a pipe wrench to disassembly a coupling, place the pipe wrench as close to the shaft threads as possible. This minimizes the possible damage to potentially packing and bearing contact surfaces on the shaft. iv) Used an emery wheel/drill motor to improve shaft surfaces that will be contact with bearings or pump packing.

#### b) Assembly Procedure:

- i) **Shaft/Coupling:** Coat all shaft threads liberally with Loctite C5-A. Insert a cotter pin into the hole located on the coupling. Screw the coupling counter-clockwise until the cotter pin makes contact with the shaft. Screw the next shaft into the coupling until it makes contact with the cotter pin. Remove the cotter pin. Screw both shafts counter clockwise until they make contact. Place pipe wrenches on the shaft, on both sides of the coupling, as close to the threads as possible (but not on the threads) and turn both pipe wrenches counter-clockwise to ensure a tight assembly.
- ii) **Shaft Housing:** Coat all shaft threads liberally with Loctite C5-A. Screw shaft housing into coupling (or pump base, or pump discharge head, as applicable).

For couplings, use the following procedure (this procedure assures even thread depth on both sides of the coupling):

- (1) Measure the length of the coupling.
- (2) Measure the length of the bearing where the diameter of the bearing is the same as that of the housing (if applicable).
- (3) Subtract the length of the bearing obtained in step b) from the length of the coupling obtained in step a). Divide this number by 2.
- (4) Screw the coupling onto the housing until the length of housing screwed into the coupling is equal to the length obtained in step c).
- (5) Insert the bearing into the coupling taper side down (such that the bearing appears to be pointing in the direction opposite that of intended flow).
- (6) Screw the other portion of the housing into the coupling.
- (7) Place pipe wrenches on the housing, on both sides of the coupling. Turn the pipe wrenches clockwise to ensure a tight assembly.

#### c) Disassembly Procedure (Use the following procedure in the event disassembly in the field is required):

- i) Place pipe wrenches on both sides of the pump housing coupling. Turn each pipe wrench counter clockwise. Once the coupling is disassembled, slide the housing so as to expose the shaft coupling. Place a pipe wrench on either side on the coupling, as close to the threads as possible (but not on the threads) and turn both pipe wrenches clockwise (coupling and pump shafts are reverse – threaded) to unscrew the shaft coupling.

- 4) Verify electrical power is OFF. Install the low level switch above minimum submergence point of the vertical turbine pumps.

- 5) For Vertical Turbine Pump Motors with Frame 324 and larger (typically 40HP and above): Remove the fill-plug and fill motor(s) with oil to the level required as indicated by the sight glass on the motor. Replace the fill plug. Approved oils are listed in the following table:

Oil Manufacturer	Ambient Temperature 5-104F ISO VG 32		Ambient Temperature 105-122F ISO VG 68	
	Mineral Based	Synthetic	Mineral Based	Synthetic
Chevron USA, Inc	GST Turbine Oil 32	Tegra 32	GST Turbine Oil 68	Tegra 68
Conoco Oil, Inc	Hydroclear Turbine Oil 32	Syncon 32	Hydroclear Turbine Oil 68	Syncon 68
Exxon Mobile	Teresstic 32	Synnestic 32	Teresstic 68	Synnestic 68
Exxon Mobile	DTE Oil Light	SHC 624	DTE Oil Heavy Medium	SHC 626
Pennzoil Co, Inc	Pennzbell TO 32	Pennzbell SHD 32	Pennzbell TO 68	Pennzbell SHD 68
Phillips Petroleum Co.	Magnus 32	Syndustrial "E" 32	Magnus 68	Syndustrial "E" 68
Shell Oil Co.	Tellus 32	Tellus HD Oil AW SHF 32	Tellus 68	Tellus HD Oil AW SHF 68
Texaco Lubricants Co.	Regal 32	Cetus PAO 32	Regal 68	Cetus PAO 68

- 6) Verify electrical power is OFF. Wire panel to ALL pump motor leads, matching color coding on power leads. Close and secure conduit box on all pump motors with provided fasteners. Verify wire tightness on all three phase and single phase connection points in electrical panel (this procedure should be repeated every six months through 18 months to ensure all the copper wire has taken its set and is not loose, and every year thereafter).
- 7) For Vertical Turbine Pump Motors: Verify the electrical power panel door is shut. Turn electrical power ON. With vertical turbine motor shafts removed and oil level in the sight glass verified, check rotation of motors (with VFD and across the line). Perform across the line rotation verification using the manual bypass start switches (ONE at a time). Perform VFD rotation verification using touch screen controls found in the Manual Mode menu on the main screen (See OI-1, Touch-screen Operation). If motors are reversed across the line, switch power to OFF, then switch any two main input power wires. Recheck rotation with VFD and across the line. If motors are reversed with VFD only, switch power to OFF, then switch any two VFD output power wires.
- 8) On Pump Motors Other Than Vertical Turbine Pump Motors: Verify the electrical power panel door is shut. Turn electrical power ON. Using a phase rotation meter/tester, check rotation of motors (with VFD and across the line). Perform across the line rotation verification using the manual bypass start switches (ONE at a time). Perform VFD rotation verification using touch screen controls found in the Manual Mode menu on the main screen (See OI-1, Touch-screen Operation). If motors are reversed across the line, switch power to OFF, then switch any two main input power wires. Recheck rotation with VFD and across the line. If motors are reversed with VFD only, switch power to OFF, then switch any two VFD output power wires.
- 9) Vertical Turbine Pump Motor Shaft Installation
- Verify electrical power is OFF.
  - Insert the motor shaft through the top of the motor. If the shaft fails to insert easily, remove the three retaining bolts at the top of the motor, removing the shaft driver fitting, and then insert the motor shaft. Re-install the fitting and replace the three retaining bolts.
  - Screw the motor shaft counter-clockwise into the coupling until it makes contact with the cotter pin. Remove the cotter pin and screw both the pump shaft and the motor shaft counter-clockwise until both shafts make contact inside the coupling.
  - Align the motor shaft groove with the motor key fitting on top of the motor. Then insert the key (completely) into the groove located on the motor shaft. This locks the motor shaft to the motor.
  - Lightly strike, in a downward fashion, the top of the motor shaft with a rubber mallet. This ensures that the pump impellers are in the bottom-most position.

- f) Screw the motor shaft retaining nut onto the motor shaft until it lightly contacts the shaft driver fitting. Using an appropriate measuring device (dial indicator), screw the motor shaft retaining nut clockwise until the impeller/bowl clearance specified in the Flowserve pump manual that accompanied the pump is met.
  - g) Continue screwing the motor shaft retaining nut until one hole on the nut becomes aligned with the retention hole on the motor shaft driver fitting. Once aligned, insert the retaining bolt and tighten to hold the nut in place.
- 10) For backwashing filters (if ordered): Attach drainage pipe/hose to filter. Ensure discharge is above the lake/reservoir level and that the size is per the specification listed on the drawing. For WYE strainers, ensure a coupling is installed close enough to the WYE strainer so as to allow for WYE strainer screen removal for cleaning purposes.
- 11) Connect the intake to the irrigation water source (does not apply to vertical turbine systems). Connect discharge to irrigation system. Ensure that the Z-pipe is properly thrust blocked and that mechanical restraint joints are used to secure the Z-pipe to irrigation connection. In general, the drainage pipe dimension is recommended to be one dimension larger than the discharge drain pipe (e.g. use a 6" drainage pipe with a 4" discharge drain pipe).
- 12) Ensure water is covering the pump impeller stack (verify low level alarm). Recheck all fasteners. If subsequent start-up of the Pump Station is to occur, ensure pump motors have been filled with oil to the minimum required level.

THIS PAGE INTENTIONALLY LEFT BLANK

## **Appendix – E: Start-Up Procedures**





## Operating Procedures

Operating Procedures (OP) – Operating procedures are used to operate the Pump Station under normal operating conditions. Proper operation of the Pump Station requires that operators do not deviate from these procedures. Deviation from these procedures can result in serious/fatal injury to personnel and/or damage to the Pump Station.

### OP1 – PUMP STATION START-UP PROCEDURE

#### Initial Conditions and Precautions

- The Pump Station has been installed in accordance with the INSTALLATION GUIDANCE AND INSTRUCTIONS.
  - Only qualified personnel shall operate the Pump Station. Personnel are considered sufficiently qualified for the assignment when they have 1) received training and had supervised experience on the task at hand; and 2) understand the safety regulations, detailed function descriptions, and operational instructions, as well as manuals for the machine/equipment assignment.
  - Prior to starting the Pump Station, ensure that no unauthorized personnel are in vicinity of pumps, electrical switchgear, or other potentially hazardous areas.
  - The electrical cabinet installed on the Pump Station has an interlock that switches electrical power OFF when the cabinet door is opened. DO NOT OVER-RIDE THIS INTERLOCK. Death or serious injury due to electrical shock can occur.
  - Never hang or store items on Pump Station piping or components.
  - Verify that pump motors have been filled with oil to the minimum required level.
  - Ensure compliance with all applicable local, state, and OSHA regulations when installing, operating, repairing, or maintaining the Pump Station.
- 1) Start-Up Procedure (See pg 22 for applicable touch-screen operation details) NOTE: Avoid high-pressure transients as these can compromise Pump Station and irrigation system integrity
    - a) Verify that the main station isolation valve from the Pump Station is shut and that on vertical turbine pump stations, pump motors have been filled with oil to the minimum required level.
    - b) Supply electrical power to the Pump Station by positioning the main power switch on the front of the electrical cabinet to the ON position.
    - c) Open taps that are furthest away from Pump Station and on the highest points.
    - d) Log-in to the touch-screen, enable only one (1) pump by pressing one of the buttons assigned to a pump at the bottom of the touch-screen panel. The pump will start as system pressure should be less than set-point pressure. NOTE: Keep the pressures at recommended value for each pump (See pre-installed value on the Operator Panel).
    - e) Partially crack open the station isolation valve (while maintaining pressure).
    - f) When the whole Main Line is filled with water and pressurized, fully open the station isolation valve. NOTE: Make sure all sprinklers are open to prime the lateral lines.
  - 2) Post Winter Shutdown Start-Up Procedure (See pg 22 for applicable touch-screen operation details)
    - a) As applicable, reassemble filters, heat exchanger, and any other components that were disassembled during winterization.
    - b) Verify that all drain valves are shut and that all drain and vent plugs have been reinstalled. Verify that all heat exchanger, pressure sensing, and gage lines are reconnected.

- c) Drain the vertical turbine pump motor oil to the minimum level as indicated in the sight glass. NOTE: Avoid high-pressure transients as these can compromise Pump Station and irrigation system integrity.
- d) Verify that the main station isolation valve from the Pump Station is shut.
- e) Supply electrical power to the Pump Station by positioning the main power switch on the front of the electrical cabinet to the ON position.
- f) Open taps that are furthest away from Pump Station and on the highest points.
- g) Log-in to the touch-screen, enable only one (1) pump by pressing one of the buttons assigned to a pump at the bottom of the touch-screen panel. The pump will start as system pressure should be less than set-point pressure. NOTE: Keep the pressures at recommended value for each pump (See pre-installed value on the Operator Panel).
- h) Partially crack open the station isolation valve (while maintaining pressure).
- i) When the whole Main Line is filled with water and pressurized, fully open the station isolation valve. **NOTE:** Make sure all sprinklers are open to prime the lateral lines.

THIS PAGE INTENTIONALLY LEFT BLANK

## **Appendix – F: Emergency Procedures**



## Emergency Procedures

Emergency Procedures (EP) - Emergency procedures are used to address unexpected conditions that could result in serious/fatal injury to personnel and/or damage to the Pump Station. Pump Station operators should thoroughly familiarize themselves with these procedures prior to operating the Pump Station.

### EP1 – FIRE

Given the non-combustible nature of the Pump Station materials, and the presence of high current/high voltage required to run pump motors, the most likely type of fire in the case of a Pump Station is a Class C fire. The single most important action in combating a Class C fire is to expeditiously shut off electrical power.

Indications: Smoke and/or flames

- 1) Fire in a Pump
  - a) Shift the main power switch on the front of the electrical panel to OFF.
  - b) If the fire does not go out upon switching the electrical power to OFF, attempt to extinguish the fire with a fire extinguisher rated for Class C fire, provided that doing so does not place the operator in a precarious situation. Contact the fire department immediately.
  - c) If the fire renders the electrical panel inaccessible, shut off power to the Pump Station via the closest accessible breaker supplying the Pump Station and contact the fire department immediately.
- 2) Fire in the Electrical Panel
  - a) Shut off power to the Pump Station via the closest accessible breaker supplying the Pump Station and contact the fire department immediately.
- 3) Fire in Pump Station Enclosure
  - a) Shut off power to the Pump Station via the closest accessible breaker supplying the pump station and contact the fire department immediately.

### EP2 – UNUSUAL PUMP OR PUMP MOTOR NOISE

Unusual pump noise is an indication that two pieces of metal that are not designed to be in contact with each other are in fact in contact with each other. Such a condition can result in serious damage to the pump and pump motor.

Indications: Metallic and/or other unusual noise. Should not be confused with the noise associated with the anti-reverse ratchets installed on vertical turbine pump motors (most pronounced on the decreasing RPM associated with shut-down); or pump cavitation.

- 1) Press the red "E-STOP" button on the front of the electrical panel.
- 2) Reset the "E-STOP" button. Use the Manual Run/Stop switches on the front of the electrical panel to quickly "bump" each pump in order to identify the pump with the unusual noise.
- 3) Once the unusual noise pump has been identified, use the main power switch on the front of the electrical panel to shut off power to the panel and open the electrical panel. Once the electrical panel is open, position the breaker for the unusual noise pump to the OFF (open) position.
- 4) Shut the panel and restore the main power switch to the ON position.
- 5) Disable the unusual noise pump using the assigned button at the bottom of the touchscreen panel and restore the rest of the Pump Station system to operation. This will allow continued turf irrigation albeit in a reduced status. Do not restore the system to operation if the suspected cause of the pump failure is due to a problem with water in the wet well.
- 6) Notify your authorized service provider of the problem as soon as possible.

**EP3 – RUPTURE**

A Pump Station Rupture is defined as a catastrophic system failure that results in significant loss of Pump Station pressure, necessarily leading to a severe degradation in the ability to provide turf irrigation (a Pump Station leak, while troublesome, does not affect Pump Station pressure nor degrade irrigation capabilities). Given the strength of the carbon steel piping, the strong anti-corrosive properties associated with the powder coat application, and the factory testing each Rain Bird Pump Station undergoes prior to shipment, a system rupture is an unlikely event. However, for purposes of completeness, a rupture emergency procedure is included as part of the Pump Station Manual.

Indications: Large amount of water flowing out of a cracked/damaged/broken Pump Station manifold, pipe, or component.

- 1) Position the main power switch on the front of the electrical panel to the OFF position.
- 2) Shut the isolation valves on the output of each pump.
- 3) Shut the isolation valve from the Pump Station to prevent water from irrigation piping back-flowing to the Pump Station once Pump Station pressure drops.
- 4) If the rupture location is on the filter assembly, it is possible to shut the filter isolation valves, open the filter bypass, and recommence Pump Station operation. Following a rupture, this should only be done after it has been deemed safe to do so by qualified personnel.
- 5) Notify Rain Bird GSP of the problem as soon as possible. See section 5.5 Global Service Plan for details.

THIS PAGE INTENTIONALLY LEFT BLANK

## **Appendix – G: Optional Item Instructions**



THIS PAGE INTENTIONALLY LEFT BLANK

# Glossary

## Glossary

2AD – 2 channel Analog to Digital converter reads 4-20mA or 0-10V signals from an analog device such as a pressure transducer or flow meter, and writes 16bit digital numbers the PLC can process.

2DA – 2 channel Digital to Analog converter reads 16bit digital numbers and creates 4-20mA or 0-10V signals to control an analog device such as a VFD or EBV.

AC – Air Conditioning

AC – Alternating Current

ASP – Authorized Service Provider

BAR – Is a pressure unit of measure. 1 BAR = 14.5PSI

BEP – Best Efficiency Point – see pump curve

BSF – Backwashing Screen Filter

CRL – Control pilot valve for the PRV

DC – Direct Current

Display – Refers to the displayed content, menu or page on a Touch Screen interface.

DOL – Direct On Line – Motor is switched to 100% speed, no VFD speed control.

EBV – Electronic Butterfly Valve

FEET – Is a pressure unit of measure. 1PSI = 2.31ft

GPM – Gallons Per Minute is a flow rate unit of measure

GSP – Global Service Plan

M3/h – Cubic Meters per hour is a flow rate unit of measure. 1GPM  $\approx$  0.227m3/h

MCSF – Minimum Continuous Stable Flow

MTF – Mini Twist Filter – Tekleen

PLC – Programmable Logic Controller

PM Pump – Pressure Maintenance Pump – usually a 3hp – 5hp pump that does not contribute flow to an irrigation system but keeps mainline pressure stable between irrigation cycles.

PRV – Pressure Relief Valve

PSI – Pounds per Square Inch is a pressure unit of measure in terms of force per area.

PSID – PSI Differential

PSIG – PSI Gauge

PTC – Push-To-Connect fitting used to quickly remove/install poly tubing.

Pump Curve – Graphical depiction of a pump's performance in terms of flow rate, pressure, efficiency and sometimes speed.

RBSC – Rain Bird Services Corporation

SAF – Scanning Automatic Filter - Amiad

Shall – Used to define a mandatory method, procedure or practice.

Should – Defines a preferred method, procedure or practice which is not mandatory.

Touch Screen – Refers to the physical Pump Station component.

VAF – Valve And Filter

VFD – Variable Frequency Drive

THIS PAGE INTENTIONALLY LEFT BLANK

## The Intelligent Use of Water.™

LEADERSHIP • EDUCATION • PARTNERSHIPS • PRODUCTS

---

At Rain Bird, we believe it is our responsibility to develop products and technologies that use water efficiently. Our commitment also extends to education, training and services for our industry and our communities.

The need to conserve water has never been greater. We want to do even more, and with your help, we can. Visit [www.rainbird.com](http://www.rainbird.com) for more information about The Intelligent Use of Water.™



**Rain Bird Corporation**

6991 E. Southpoint Road  
Tucson, AZ 85756  
Phone: (520) 741-6100  
Fax: (520) 741-6522

**Rain Bird Technical Services**

(800) RAINBIRD (1-800-724-6247)  
(U.S. and Canada)

**Rain Bird Corporation**

970 West Sierra Madre Avenue  
Azusa, CA 91702  
Phone: (626) 812-3400  
Fax: (626) 812-3411

**Specification Hotline**

800-458-3005 (U.S. and Canada)

**Rain Bird International, Inc.**

1000 West Sierra Madre  
Azusa, CA 91702  
Phone: (626) 963-9311  
Fax: (626) 852-7343

[www.rainbird.com](http://www.rainbird.com)