

# **L8160/L8180 User's Guide**



---

# Contents

<b>L8160/L8180 User's Guide .....</b>	<b>13</b>
<b>Product Basics .....</b>	<b>14</b>
Product Parts Locations .....	14
Product Parts - Front .....	15
Product Parts - Inside .....	17
Product Parts - Back .....	18
Using the Control Panel .....	18
The LCD Screen .....	19
Status Icon Information .....	20
Navigating the LCD Screen .....	21
Entering Characters on the LCD Screen .....	22
Adjusting Control Panel Sounds .....	23
Adjusting the Screen Brightness .....	24
Changing LCD Screen Language .....	25
Viewing Animations .....	26
Turning Off Auto Selection Mode .....	27
Using Power Saving Settings .....	28
Changing the Sleep Timer Settings .....	28
Changing the Power Off Timer Settings .....	29
Epson Connect Solutions for Smartphones, Tablets, and More .....	30
Setting Up Epson Connect Services .....	30
Using Epson Email Print .....	31
Using Epson Remote Print .....	32
Using Epson Scan to Cloud .....	32
Using the Epson Smart Panel Mobile App .....	33
Setting Up Printing on a Chromebook .....	34
Using AirPrint .....	34
Android Printing Using the Epson Print Enabler .....	35
Using Fire OS Printing .....	35
Using Windows 10 Mobile Printing .....	36

Using Epson Print and Scan App with Windows Tablets .....	36
Using the Mopria Print Service .....	37
<b>Wi-Fi or Wired Networking</b> .....	<b>38</b>
Network Security Recommendations .....	38
Wi-Fi Infrastructure Mode Setup.....	39
Selecting Wireless Network Settings from the Control Panel .....	40
Setting Up Wireless Printing from a Smartphone or Tablet.....	42
Wi-Fi Direct Mode Setup .....	43
Enabling Wi-Fi Direct Mode (Simple AP) .....	44
Wi-Fi Protected Setup (WPS).....	45
Using WPS to Connect to a Network .....	45
Printing a Network Status Sheet.....	46
Printing a Network Connection Report .....	47
Network Connection Report Codes and Messages .....	48
Changing or Updating Network Connections .....	54
Accessing the Web Config Utility .....	54
Changing a USB Connection to a Wi-Fi Connection.....	55
Changing a Wi-Fi Connection to a Wired Network Connection.....	55
Connecting to a New Wi-Fi Router .....	56
Disabling Wi-Fi Features .....	56
<b>Loading Paper</b> .....	<b>58</b>
Loading Paper in Cassette 1 (Upper Cassette) .....	58
Loading Paper in Cassette 2 (Lower Cassette) .....	63
Loading Paper in the Rear of Your Product.....	68
Turning Off the Paper Mismatch Alert .....	72
Paper Loading Capacity .....	73
Double-sided Printing Capacity .....	75
Borderless Paper Type Compatibility .....	76
Compatible Epson Papers.....	77
Selecting the Paper Settings for Each Source - Control Panel .....	80
Paper or Media Type Settings - Control Panel.....	81
Paper or Media Type Settings - Printing Software .....	82

<b>Placing Originals on the Product</b> .....	<b>83</b>
Placing Originals on the Scanner Glass .....	83
<b>Copying</b> .....	<b>86</b>
Copying Documents or Photos .....	86
Restoring Photos While Copying .....	87
Copying Books, ID Cards, or Borderless Photos .....	89
Copying Options .....	90
<b>Printing from a Computer</b> .....	<b>93</b>
Printing with Windows .....	93
Selecting Basic Print Settings - Windows .....	94
Paper Source Options - Windows .....	96
Print Quality Options - Windows .....	96
Multi-Page Printing Options - Windows .....	97
Selecting Double-sided Printing Settings - Windows .....	97
Double-sided Printing Options - Windows .....	100
Print Density Adjustments - Windows .....	100
Selecting Additional Layout and Print Options - Windows .....	101
Custom Color Correction Options - Windows .....	103
Image Options and Additional Settings - Windows .....	104
Header/Footer Settings - Windows .....	105
Selecting a Printing Preset - Windows .....	106
Selecting Extended Settings - Windows .....	108
Extended Settings - Windows .....	109
Printing Your Document or Photo - Windows .....	111
Checking Print Status - Windows .....	112
Selecting Default Print Settings - Windows .....	113
Changing the Language of the Printer Software Screens .....	114
Changing Automatic Update Options .....	115
Printing with the Built-in Epson Driver - Windows 10 S .....	116
Selecting Print Settings - Windows 10 S .....	116
Printing on a Mac .....	120
Selecting Basic Print Settings - Mac .....	121
Paper Source Options - Mac .....	125

Print Quality Settings - Mac.....	125
Selecting Page Setup Settings - Mac .....	126
Selecting Print Layout Options - Mac.....	127
Selecting Double-sided Printing Settings - Mac.....	127
Double-sided Printing Options and Adjustments - Mac.....	129
Managing Color - Mac .....	129
Color Matching and Color Options - Mac .....	130
Selecting Printing Preferences - Mac .....	131
Printing Preferences - Mac.....	132
Printing Your Document or Photo - Mac .....	133
Checking Print Status - Mac.....	133
Printing from a Smartphone or Tablet.....	134
Printing with Epson Photo+ .....	135
Cancelling Printing From the LCD Screen.....	135
<b>Scanning .....</b>	<b>136</b>
Starting a Scan.....	136
Starting a Scan Using the Product Control Panel .....	136
Scanning to a Memory Device .....	138
Scanning to a Connected Computer .....	139
Scanning to the Cloud.....	141
Setting Up a WSD Port (Windows 7/Windows Vista) .....	142
Control Panel Scanning Options.....	143
Changing Default Scan Job Settings .....	144
Starting a Scan Using Epson ScanSmart .....	145
Starting a Scan Using the Epson Scan 2 Icon .....	146
Starting a Scan from a Scanning Program.....	148
Starting a Scan from a Smartphone or Tablet.....	150
Scanning a Document or Photo in Epson ScanSmart .....	150
Saving a Scan .....	153
Attaching a Scan to Email.....	154
Sending a Scan to a Cloud Service .....	155
Printing a Scan .....	156
Selecting Epson ScanSmart Settings.....	158

Changing the Epson Product.....	158
Changing the Scan Settings .....	159
Changing the File Name Settings .....	161
Changing the Save Settings .....	162
Save Settings.....	164
Customizing Action Icons .....	166
Scanning in Epson Scan 2 .....	167
Additional Scanning Settings - Main Settings Tab .....	170
Additional Scanning Settings - Advanced Settings Tab .....	171
Saving Scanned Documents as a Searchable PDF Using Epson Scan 2 .....	172
Image Format Options.....	173
Scan Resolution Guidelines .....	174
<b>Using Memory Cards with Your Product.....</b>	<b>176</b>
Inserting a Memory Card.....	176
Removing a Memory Card.....	178
Printing from a Memory Card .....	179
Viewing and Printing Photos.....	179
Viewing and Printing Photos From the LCD Screen.....	179
Memory Card or External USB Device Print Settings.....	182
Printing Photo Layouts from a Memory Card with a Template .....	184
Printing ID Photos from a Memory Card .....	187
Creating and Printing a Greeting Card Template.....	190
Printing a Greeting Card from a Template .....	192
Transferring Photos on a Memory Card .....	193
Setting Up File Sharing for Photo Transfers from Your Computer .....	193
Transferring Photos from a Memory Card to Your Computer .....	194
<b>Using an External Device with Your Product .....</b>	<b>196</b>
Printing from a Camera .....	196
Selecting Print and Photo Adjustment Settings .....	196
Print Settings - Camera.....	198
Photo Adjustments - Camera.....	200
Connecting and Printing from a Camera.....	201
Printing from a Camera Wirelessly .....	202

Viewing or Printing from a USB Flash Drive or External Device .....	203
Connecting and Using a USB Flash Drive or External Device .....	203
<b>Printing Personalized Projects.....</b>	<b>206</b>
Printing a Personalized Project .....	206
<b>Printing on CDs/DVDs .....</b>	<b>208</b>
CD/DVD Printing Features .....	208
Loading a CD/DVD .....	208
Copying onto a CD/DVD .....	210
<b>Refilling Ink and Replacing the Maintenance Box .....</b>	<b>213</b>
Ink Safety Precautions .....	213
Checking the Ink and Maintenance Box Levels.....	215
Checking the Ink Levels on Your Product.....	216
Checking Maintenance Box Status on the LCD Screen.....	216
Checking Ink and Maintenance Box Levels - Windows .....	217
Checking Ink and Maintenance Box Levels - Mac .....	219
Disabling Special Offers with Windows .....	220
Purchase Epson Ink and Maintenance Box.....	221
Ink Bottle and Maintenance Box Part Numbers .....	222
Refilling the Ink Tanks .....	222
Maintenance Box Replacement .....	227
<b>Adjusting Print Quality.....</b>	<b>229</b>
Print Head Maintenance.....	229
Print Head Nozzle Check.....	229
Checking the Nozzles Using the Product Control Panel .....	230
Checking the Nozzles Using a Computer Utility .....	232
Print Head Cleaning .....	233
Cleaning the Print Head Using the Product Control Panel .....	234
Cleaning the Print Head Using a Computer Utility.....	235
Print Quality Adjustment.....	238
Aligning the Print Head Using the Product Control Panel .....	238
Power Cleaning.....	240
Power Cleaning Using the Product Control Panel .....	240



Cleaning the Paper Guide .....	241
Cleaning the Paper Path .....	244
Cleaning the Translucent Film.....	246
Cleaning the Paper Rollers .....	248
Checking the Number of Sheets Fed.....	251
Checking the Number of Sheets on the LCD Screen.....	252
Checking the Sheet Counter - Windows .....	252
Checking the Sheet Counter - Mac.....	253
<b>Cleaning and Transporting Your Product .....</b>	<b>254</b>
Cleaning Your Product .....	254
Transporting Your Product .....	255
<b>Solving Problems .....</b>	<b>263</b>
Checking for Software Updates.....	263
Viewing the Help Screen .....	264
Product Status Messages .....	264
Running a Product Check .....	269
Resetting Control Panel Defaults .....	270
Solving Setup Problems .....	271
Product Does Not Turn On or Off.....	272
Noise After Filling the Ink.....	272
Message Appears Prompting You to Reset Ink Levels.....	272
Software Installation Problems .....	273
Solving Network Problems .....	273
Product Cannot Connect to a Wireless Router or Access Point .....	274
Network Software Cannot Find Product on a Network.....	275
Product Does Not Appear in Mac Printer Window .....	277
Wireless Network Connection is Unstable on a Mac .....	277
Wired Network Connection Becomes Unstable.....	277
Cannot Print Over a Network.....	278
Cannot Scan Over a Network .....	279
Solving Copying Problems .....	280
Product Makes Noise, But Nothing Copies.....	281
Product Makes Noise When It Sits for a While.....	281

Solving Paper Problems .....	281
Paper Feeding Problems .....	282
Paper Jam Problems in the Paper Cassettes .....	283
Paper Jam Problems Inside the Product .....	284
Paper Jam Problems in the Rear Cover .....	286
Rear Paper Support Problems .....	290
Paper Ejection Problems .....	290
Solving Problems Printing from a Computer .....	290
Nothing Prints .....	291
Product Icon Does Not Appear in Windows Taskbar .....	292
Printing is Slow .....	292
Solving Page Layout and Content Problems .....	294
Inverted Image .....	294
Too Many Copies Print .....	295
Blank Pages Print .....	295
Incorrect Margins on Printout .....	296
Border Appears on Borderless Prints .....	296
Incorrect Characters Print .....	297
Incorrect Image Size or Position .....	297
Slanted Printout .....	298
Solving Print Quality Problems .....	299
White or Dark Lines in Printout .....	299
Blurry or Smearred Printout .....	300
Faint Printout or Printout Has Gaps .....	302
Grainy Printout .....	303
Incorrect Colors .....	304
Solving Scanning Problems .....	305
Scanning Software Does Not Operate Correctly .....	306
Cannot Start Epson Scan 2 .....	306
Scanning is Slow .....	307
Cannot Send Scans to a Cloud Service .....	308
Solving Scanned Image Quality Problems .....	308
Image Consists of a Few Dots Only .....	308

Line of Dots Appears in All Scanned Images .....	309
Straight Lines in an Image Appear Crooked .....	309
Scanned Image Quality Problems .....	310
Characters are Not Recognized During Conversion to Editable Text (OCR).....	311
Image Colors are Patchy at the Edges .....	312
Ripple Patterns Appear in an Image .....	312
Streaks Appear in All Scanned Images .....	312
Scanned Image Edges are Cropped .....	313
Resetting the Epson Scan 2 Settings .....	313
Solving Memory Card Problems.....	313
Memory Card Does Not Fit Into a Slot .....	314
Cannot View or Print Photos from a Memory Card or Device .....	314
Cannot Transfer Photos to or from a Memory Card or Device .....	315
Solving USB Device Problems .....	315
Cannot View or Print from a USB Device.....	315
Cannot Save Files on a USB Device .....	316
Cannot Transfer Files To or From a USB Device.....	316
Solving CD/DVD Problems.....	316
Problems Printing on CDs/DVDs.....	317
Uninstall Your Product Software.....	318
Uninstalling Product Software - Windows.....	318
Uninstalling Product Software - Mac.....	319
Where to Get Help.....	320
<b>Technical Specifications .....</b>	<b>323</b>
Windows System Requirements .....	323
Mac System Requirements .....	324
Paper Specifications .....	325
Printable Area Specifications .....	326
Scanning Specifications .....	328
Ink Specifications .....	328
Dimension Specifications .....	329
Electrical Specifications .....	330
Environmental Specifications .....	331

Interface Specifications .....	331
Memory Card Specifications .....	331
External Device Specifications .....	332
Supported Data Specifications .....	333
Network Interface Specifications .....	333
<b>Notices .....</b>	<b>335</b>
Important Safety Instructions.....	335
General Product Safety Instructions .....	335
Wireless Connection Safety Instructions .....	337
LCD Screen Safety Instructions.....	337
FCC Compliance Statement.....	338
Binding Arbitration and Class Waiver .....	339
Trademarks .....	342
Copyright Notice.....	342
libTIFF Software Acknowledgment.....	343
A Note Concerning Responsible Use of Copyrighted Materials.....	344
Default Delay Times for Power Management for Epson Products .....	344
Copyright Attribution .....	344

---

## L8160/L8180 User's Guide

Welcome to the L8160/L8180 *User's Guide*.

For a printable PDF copy of this guide, [click here](#).

**Note:** The L8160 illustrations and menu screens are shown throughout this guide, unless noted otherwise.

**Note:** Availability of products in this guide varies by country.

---

## Product Basics

See these sections to learn about the basic features of your product.

[Product Parts Locations](#)

[Using the Control Panel](#)

[Using Power Saving Settings](#)

[Epson Connect Solutions for Smartphones, Tablets, and More](#)

[Using the Epson Smart Panel Mobile App](#)

[Setting Up Printing on a Chromebook](#)

[Using AirPrint](#)

[Android Printing Using the Epson Print Enabler](#)

[Using Fire OS Printing](#)

[Using Windows 10 Mobile Printing](#)

[Using Epson Print and Scan App with Windows Tablets](#)

[Using the Mopria Print Service](#)

## Product Parts Locations

See these sections to identify the parts on your product.

[Product Parts - Front](#)

[Product Parts - Inside](#)

[Product Parts - Back](#)

**Parent topic:** [Product Basics](#)

## Product Parts - Front

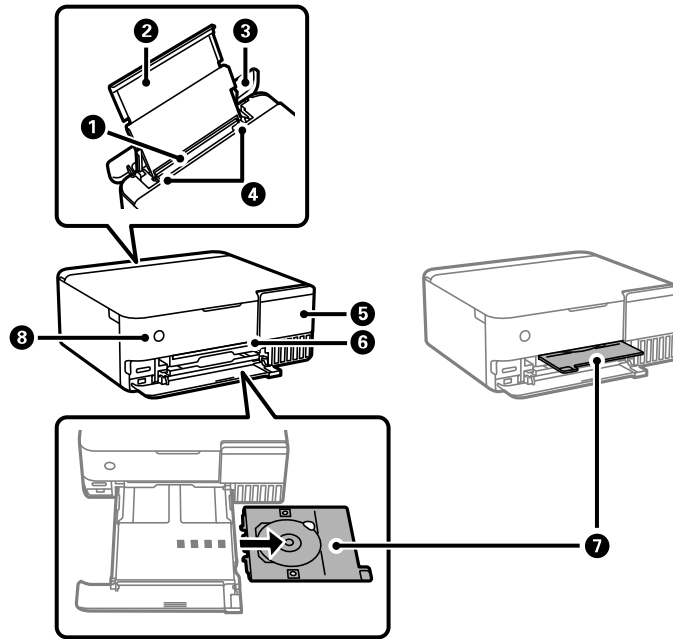

- 1 Rear paper feeder
- 2 Rear paper support
- 3 Rear paper feeder cover
- 4 Edge guides
- 5 Control panel (raise or lower to adjust)
- 6 CD/DVD tray slot
- 7 CD/DVD tray

8  power button and light

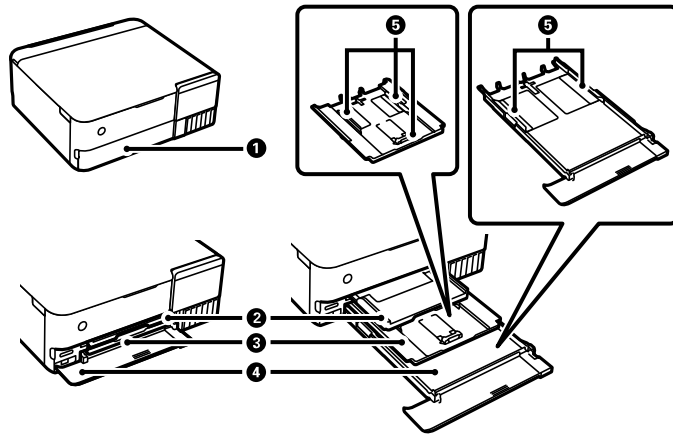

- 1 Front cover
- 2 Output tray
- 3 Paper cassette 1
- 4 Paper cassette 2
- 5 Edge guides

Parent topic: [Product Parts Locations](#)



## Product Parts - Inside

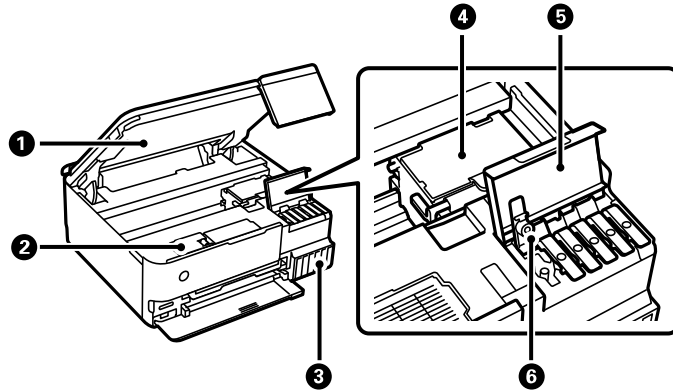

- 1 Scanner unit
- 2 Maintenance box cover
- 3 Ink tank unit
- 4 Print head
- 5 Ink tank cover
- 6 Ink tank cap

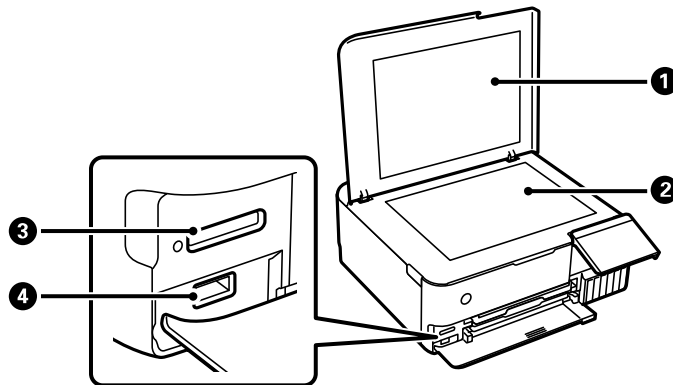

- 1 Document cover
- 2 Scanner glass
- 3 Memory card slot
- 4  USB port for external USB devices

Parent topic: [Product Parts Locations](#)

## Product Parts - Back

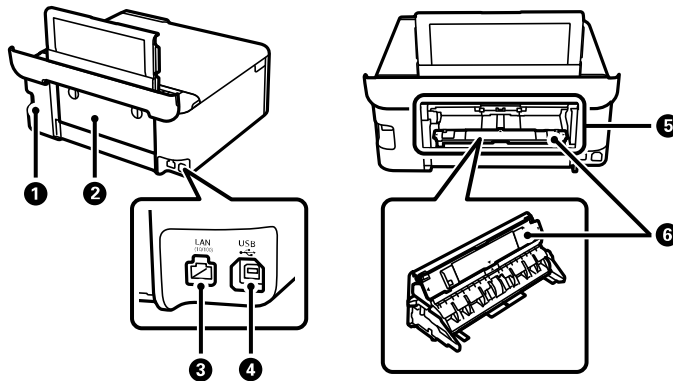

- 1 AC inlet
- 2 Rear cover (duplexer)
- 3 **LAN** port
- 4 **USB** port for computer connections
- 5 Rear paper feed slot
- 6 Paper feed unit (for rear paper feed slot)

Parent topic: [Product Parts Locations](#)

## Using the Control Panel

See these sections to learn about the control panel and select control panel settings.

[The LCD Screen](#)

- Status Icon Information
- Navigating the LCD Screen
- Entering Characters on the LCD Screen
- Adjusting Control Panel Sounds
- Adjusting the Screen Brightness
- Changing LCD Screen Language
- Viewing Animations
- Turning Off Auto Selection Mode

**Parent topic:** Product Basics

## The LCD Screen

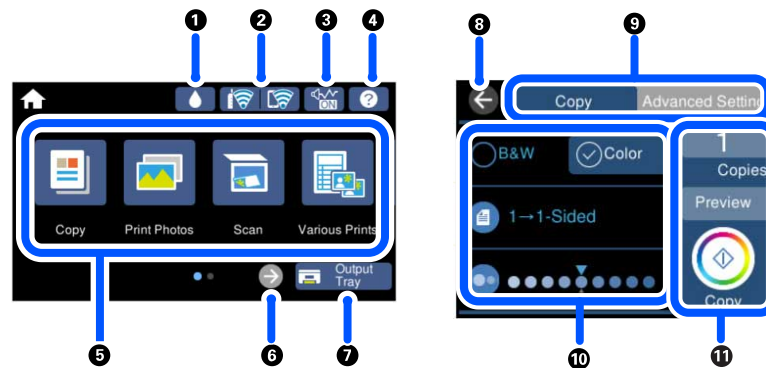













- 1 Displays the **Supply Status** screen
- 2 Displays the network connection status
- 3 Displays the **Quiet Mode** screen
- 4 Displays the **Help** screen
- 5 Menu options
- 6 Scrolls the screen to the right
- 7 Stores the output tray
- 8 Returns to the previous screen
- 9 Select a tab to view different options and settings

- 10 Settings options
- 11 Displays available options

Parent topic: [Using the Control Panel](#)

## Status Icon Information

Your product displays status icons on the LCD screen for certain product status conditions.

Icons	Description
	Displays the <b>Supply Status</b> screen.
	<p>Displays the network connection status; select the icon to set up or change your network connection.</p> <ul style="list-style-type: none"> <li>•  The product is not connected to a wired (Ethernet) network.</li> <li>•  The product is connected to a wired (Ethernet) network.</li> <li>•  The product is searching for an SSID or experiencing a wireless network connection issue.</li> <li>•  The product is connected to a wireless network; the number of bars indicates the connection's signal strength.</li> <li>•  Wi-Fi Direct is not enabled.</li> <li>•  Wi-Fi Direct is enabled.</li> </ul>
 	The <b>Quiet Mode</b> setting is enabled or disabled. Select the icon to change the setting. Depending on the selected paper type and print quality, when this feature is enabled noise is reduced during printing at the cost of print speed.
	Displays the <b>Help</b> screen.
	Closes the output tray.
	Displays additional information or instructions, such as loading paper or placing a document on the scanner; select the icon to display the information.

Icons	Description
	There is a problem with the indicated setting; select the icon for information on resolving the problem.

Parent topic: [Using the Control Panel](#)

## Navigating the LCD Screen

Follow these guidelines to navigate and use the menus on the LCD screen.



Tap or press the screen to select an item or icon



Flick the screen to scroll swiftly



Slide your finger across the screen to move items



Close or open your fingers across the screen to zoom in or zoom out on a preview image



To change a setting, tap anywhere on the setting.

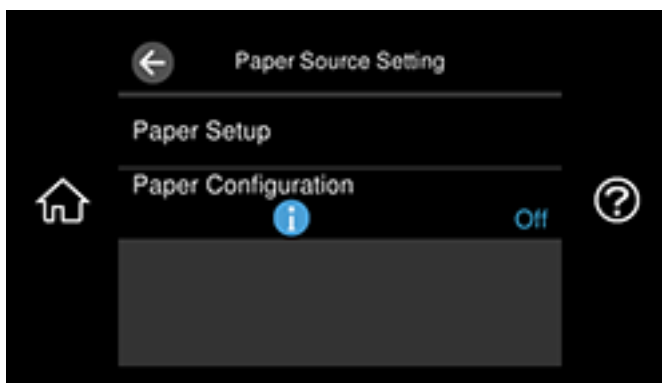

To enter a value in a field, tap the field to display the on-screen keyboard.



Parent topic: [Using the Control Panel](#)

## Entering Characters on the LCD Screen

Follow these guidelines to enter characters for passwords and other settings.

### On-screen keyboard

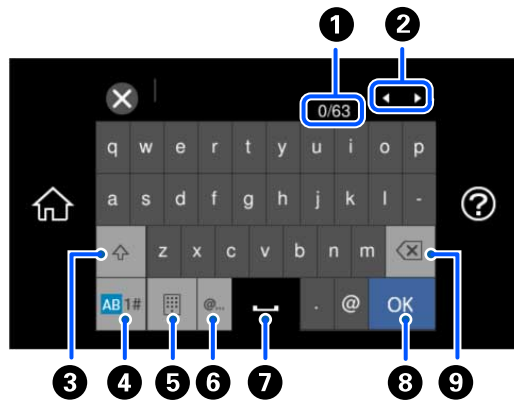

- 1 Displays the character count
- 2 Moves the cursor left or right

- 3 Switches between uppercase and lowercase characters
- 4 Switches between characters and numbers or symbols
- 5 Changes the keyboard layout
- 6 Displays a list of common domain names to choose from
- 7 Enters a space
- 8 Select when you are finished
- 9 Deletes the previous character

### On-screen keypad

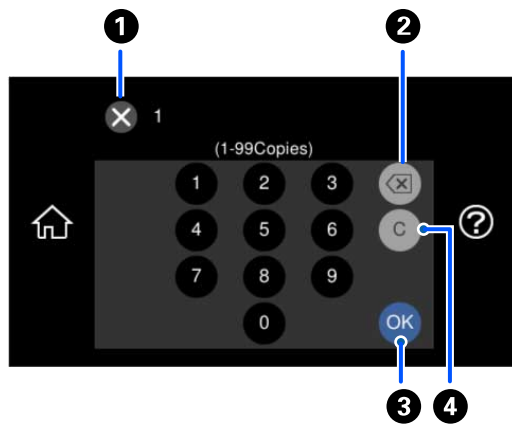

- 1 Cancels entry and closes the keypad
- 2 Deletes the previous number
- 3 Select when you are finished
- 4 Clears the entered number

Parent topic: [Using the Control Panel](#)

## Adjusting Control Panel Sounds

You can adjust the sound level heard when you press buttons on the control panel.

1. Select the  home icon, if necessary.
2. Select **Settings** > **Basic Settings** > **Sound**.

You see a screen like this:

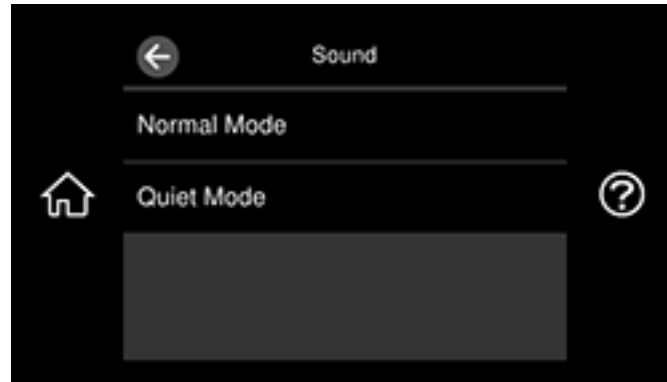

3. Select **Normal Mode** or **Quiet Mode**.

**Note:** You can also press the  icon on the home screen to switch between **Normal Mode** and **Quiet Mode**.

4. Do one of the following:
  - Select **Button Press**.
  - Select **Error Tone**.
5. Select the – or + icon to adjust the volume.
6. Select **OK** to exit.

**Parent topic:** [Using the Control Panel](#)

## Adjusting the Screen Brightness

You can adjust the brightness of the LCD screen.

1. Select the  home icon, if necessary.



2. Select **Settings** > **Basic Settings** > **LCD Brightness**.



**Note:** If you want to change the background color entirely, select **Settings** > **Basic Settings** > **Background Color**.

3. Select the – or + button to adjust the brightness.
4. Select **OK** to exit.

**Parent topic:** [Using the Control Panel](#)

## Changing LCD Screen Language

You can change the language used on the LCD screen.

1. Select the  home icon, if necessary.
2. Select **Settings** > **Basic Settings** > **Language**.

You see a screen like this:

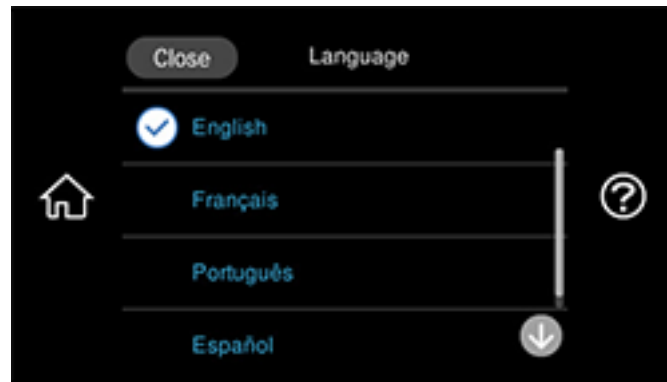

3. Select a language.
4. Select the  home icon to exit.

Parent topic: [Using the Control Panel](#)

## Viewing Animations

You can view animations on the LCD screen to help guide you with a procedure or to troubleshoot a problem.

1. Select the  help icon.

You see a screen like this:

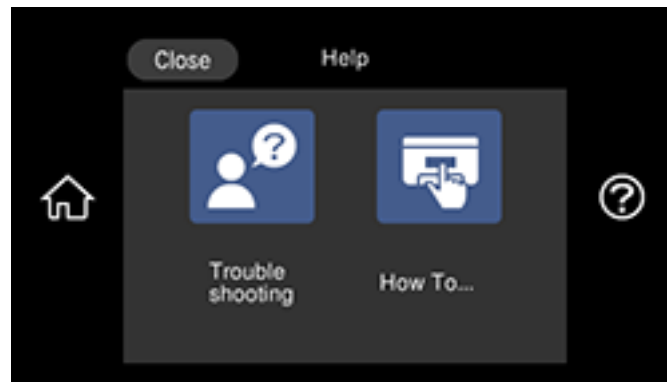

2. Select **Troubleshooting** if you are experiencing a problem or **How To** to view instructions on common procedures.
3. Select a topic from the list of available topics and follow the on-screen instructions.

While viewing the topics, you may see screens like this:

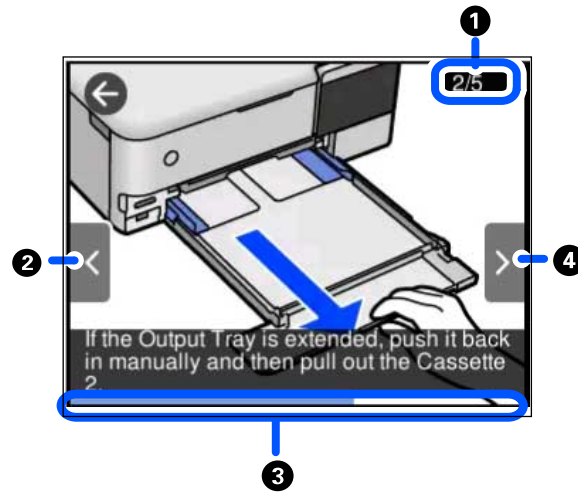

- 1 Displays the current step number and the total number of steps
- 2 Select the left arrow button to view the previous step
- 3 Indicates your overall progress through the animation
- 4 Select the right arrow button to view the next step

Parent topic: [Using the Control Panel](#)

## Turning Off Auto Selection Mode

Auto Selection Mode changes the menu options on the LCD screen automatically depending on the action you perform. For example, loading a memory card automatically displays memory card-related menu options on the screen. You can turn off this feature if desired.

1. Select the  home icon, if necessary.
2. Select **Settings** > **Guide Functions** > **Auto Selection Mode**.

You see a screen like this:

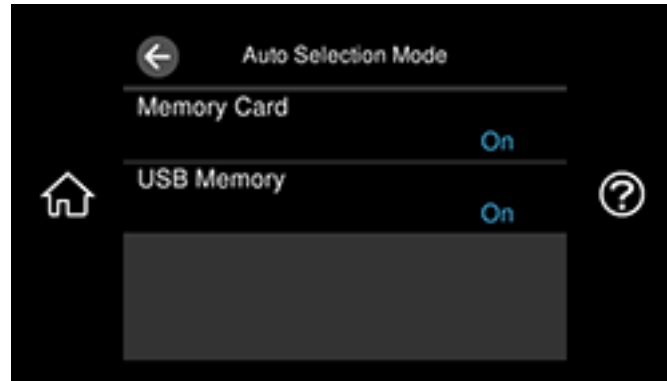

3. Select **Off** for the options displayed as necessary.
4. Select the  home icon to exit.

Parent topic: [Using the Control Panel](#)

## Using Power Saving Settings

Your product enters sleep mode automatically and turns off the LCD screen if it is not used for a period of time. You can make the time period shorter and select other options to save energy and resources.

[Changing the Sleep Timer Settings](#)

[Changing the Power Off Timer Settings](#)

Parent topic: [Product Basics](#)

## Changing the Sleep Timer Settings

You can adjust the time period before your product enters sleep mode and turns off the LCD screen.

1. Select the  home icon, if necessary.
2. Select **Settings** > **Basic Settings** > **Sleep Timer**.

You see a screen like this:

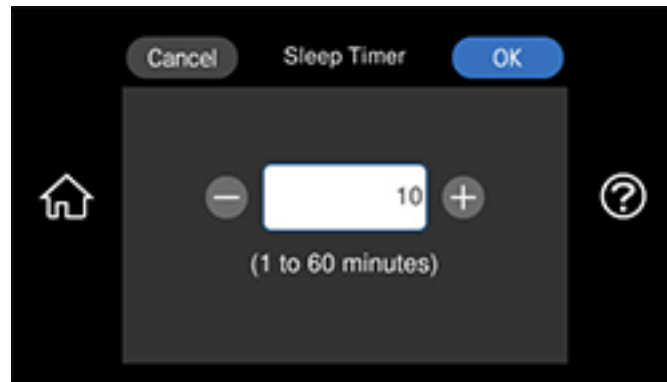

3. Select a time period between 1 and 60 minutes.

**Parent topic:** [Using Power Saving Settings](#)

## Changing the Power Off Timer Settings

You can have the product turn off automatically if it is not used for a specified period of time.

1. Select the  home icon, if necessary.
2. Select **Settings** > **Basic Settings** > **Power Off Timer**.

You see a screen like this:

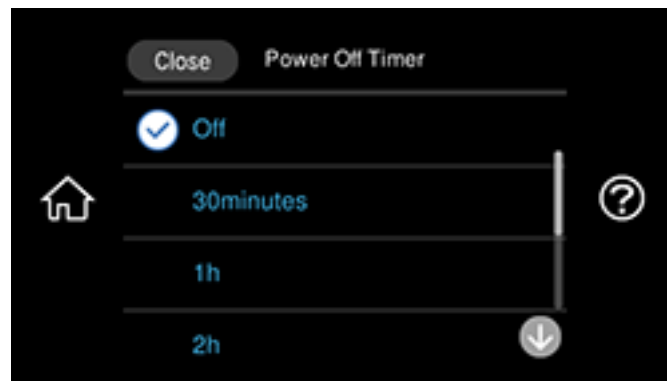

3. Select a time period between 30 minutes and 12 hours.

**Parent topic:** [Using Power Saving Settings](#)

## Epson Connect Solutions for Smartphones, Tablets, and More

Use your smartphone, tablet, or computer to print and scan documents, photos, emails, and web pages from your home, office, or even across the globe.

**Note:** If you are using your Epson product with the Windows 10 S operating system, you cannot use the software described in this section. You also cannot download and install any Epson product software from the Epson website for use with Windows 10 S; you must obtain software only from the Windows Store.

Print from anywhere with these Epson Connect solutions:

- Epson Email Print
- Epson Remote Print

Scan and send a file as an email or upload it to an online service directly from your Epson product with Epson Scan to Cloud.

[Setting Up Epson Connect Services](#)

[Using Epson Email Print](#)

[Using Epson Remote Print](#)

[Using Epson Scan to Cloud](#)

**Parent topic:** [Product Basics](#)

## Setting Up Epson Connect Services

If you did not activate your product's email address for use with Epson Connect when you set up your product, you can activate it using the product control panel.

1. Select the  home icon, if necessary.
2. Select **Settings > Web Service Settings > Epson Connect Services**.

You see a screen like this:

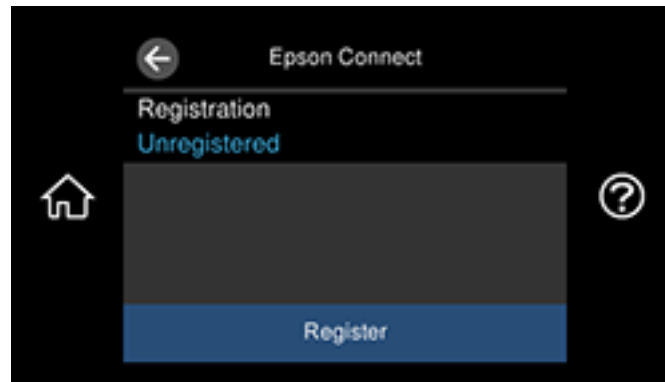

3. Select **Register**.
4. Follow the instructions on the screen to activate your product's email address.

**Parent topic:** [Epson Connect Solutions for Smartphones, Tablets, and More](#)

**Related topics**

[Wi-Fi or Wired Networking](#)

## Using Epson Email Print

With Epson Email Print, you can print from any device that can send email, such as your smartphone, tablet, or laptop. Just activate your product's unique email address. When you want to print, attach a PDF, Microsoft Office document, or photo to an email and send it to your product. Both the email and the attachments will print automatically.

1. Connect your product to your network. See the link below.
2. If you did not already set up Email Print when you installed your product software, see the link below to use your product control panel to activate your unique email address. Or visit [epsonconnect.com](http://epsonconnect.com) to learn more about Email Print, create your Epson Connect account, and register your product to the Epson Connect service.
3. Now you are ready to send and print emails to your product's Email Print address.

**Note:** Go to [epsonconnect.com](http://epsonconnect.com) and log into your Epson Connect account to personalize your product's email, adjust print settings, and set up other Epson Connect services.

**Parent topic:** [Epson Connect Solutions for Smartphones, Tablets, and More](#)

**Related tasks**

[Setting Up Epson Connect Services](#)

**Related topics**

[Wi-Fi or Wired Networking](#)

## Using Epson Remote Print

With Epson Remote Print software, you can print from your laptop or desktop computer to an Epson Email-enabled product anywhere in the world.

1. Connect your Epson product to your wireless network. See the link below.
2. If you did not already set up an Epson Connect account when you installed your product software, visit [epsonconnect.com](http://epsonconnect.com) to create your account and register your product to the Epson Connect service.

**Note:** Make a note of your product's email address.

3. Visit [epsonconnect.com](http://epsonconnect.com) to learn more about Remote Print and how to download the Remote Print Driver software.
4. Download and install the Remote Print software.
5. Enter the email address and optional access key of your Epson product during Remote Print setup.
6. Now you are ready to print remotely. Select the print command in your laptop or desktop computer application and choose the Remote Print option for your Epson product.

**Parent topic:** [Epson Connect Solutions for Smartphones, Tablets, and More](#)

**Related topics**

[Wi-Fi or Wired Networking](#)

## Using Epson Scan to Cloud

The Epson Scan to Cloud service allows you to scan and send a file as an email or upload it to an online service directly from your Epson product. Register an email address or online services such as Box, DropBox, Evernote, or Google Drive with your Epson Connect account.

1. Connect your Epson product to your network. See the link below.



2. If you did not already set up an Epson Connect account when you installed your product software, visit [epsonconnect.com](http://epsonconnect.com) to create your account and register your product to the Epson Connect service.

**Note:** Make a note of your product's email address and password.

3. Visit [epsonconnect.com](http://epsonconnect.com) to sign into your account with the email address and password you selected.
4. Select your product, select **Scan to Cloud**, and select **Destination List**.
5. Click **Add**, then follow the instructions on the screen to create your destination list.
6. Now you are ready to use Scan to Cloud. Select the setting for scanning to Scan to Cloud on your Epson product control panel.

**Parent topic:** [Epson Connect Solutions for Smartphones, Tablets, and More](#)

#### **Related tasks**

[Scanning to the Cloud](#)

#### **Related topics**

[Wi-Fi or Wired Networking](#)

## **Using the Epson Smart Panel Mobile App**

Use this free Apple and Android app to set up your Epson product and then print, copy, or scan with your networked Epson product. Epson Smart Panel also lets you check ink levels and product status.

1. Visit [latin.epson.com/connect](http://latin.epson.com/connect) to learn more about Epson Smart Panel and check the compatibility of your mobile device.
2. Download Epson Smart Panel from the Apple App Store or Google Play.
3. Connect your mobile device to the wireless network that you want to connect your product to or to the same wireless network as your product (if your product is already set up).
4. Do one of the following:
  - If you haven't set up your product, open Epson Smart Panel and follow the instructions to set up your product.
  - If your product is already set up, open Epson Smart Panel and select your Epson product, if necessary.

Now you are ready to print, copy, or scan with your mobile device and your Epson product.

**Parent topic:** [Product Basics](#)

### Related topics

[Wi-Fi or Wired Networking](#)

## Setting Up Printing on a Chromebook

Your Epson printer supports native printing on Chromebook, allowing you to print from a Chromebook without drivers or cables.

For directions on setting up your printer, visit the [Setting Up Your Epson Printer on Your Chromebook](#) site.

**Parent topic:** [Product Basics](#)

## Using AirPrint

AirPrint enables instant wireless printing from iPhone, iPad, iPod touch, and Mac without the need to install drivers or download software.



**Note:** If you disabled paper configuration messages on your product control panel, you cannot use AirPrint. See the link below to enable the messages, if necessary.

1. Load paper in your product.
2. Set up your product for wireless printing. See the link below.
3. Connect your Apple device to the same wireless network that your product is using.
4. Print from your device to your product.

**Note:** For details, see the AirPrint page on the Apple website.

**Parent topic:** [Product Basics](#)

### Related tasks

[Turning Off the Paper Mismatch Alert](#)

### Related topics

[Wi-Fi or Wired Networking](#)

## Android Printing Using the Epson Print Enabler

You can wirelessly print your documents, emails, photos, and web pages right from your Android phone or tablet (Android v4.4 or later). With a few taps, your Android device will discover your nearby Epson product and print.

1. Connect your Epson product to your wireless network. See the link below.
2. On your Android device, download the Epson Print Enabler plug-in from Google Play.
3. Go to **Settings** on your Android device, select **Printing**, and enable the Epson plug-in, if necessary.
4. Connect your Android device to the same wireless network as your product.
5. Now you are ready to print. From an Android application such as Chrome or Gmail, tap the menu icon and print whatever is on the screen.

**Note:** If you do not see your product, tap **All Printers** and select your product.

**Parent topic:** [Product Basics](#)

### Related topics

[Wi-Fi or Wired Networking](#)

## Using Fire OS Printing

You can wirelessly print from Amazon Fire tablets and phones to your nearby networked Epson product. There is no software to download, no drivers to install, and no cables to connect. With just a few taps in Email, Calendar, Contacts, and WPS Office, you can send whatever is on the screen to an Epson product.

1. Connect your Epson product to your wireless network. See the link below.
2. Connect your Amazon device to the same wireless network as your product.
3. Now you are ready to print. From your Amazon application, tap the print option and select your product to print whatever is on the screen.

**Note:** If you see a message telling you that a plug-in is required, tap **OK** and tap **Download**. If your Amazon Fire product uses Fire OS 5 and above, your device automatically uses the built-in Mopria Print Service app to print.

**Parent topic:** [Product Basics](#)

### Related topics

[Wi-Fi or Wired Networking](#)

## Using Windows 10 Mobile Printing

You can wirelessly print from Windows 10 Mobile tablets and phones to your nearby networked Epson product. There is no software to download, no drivers to install, and no cables to connect. Look for the print option in your Windows 10 application to send whatever is on the screen to an Epson product.

1. Connect your Epson product to your wireless network. See the link below.
2. Connect your Windows 10 Mobile device to the same wireless network as your product.
3. Now you are ready to print. From your Windows 10 application, tap the print option and select your product to print whatever is on the screen.

**Parent topic:** [Product Basics](#)

### Related topics

[Wi-Fi or Wired Networking](#)

## Using Epson Print and Scan App with Windows Tablets

You can use this free app to print photos and scan from your Windows (Windows 8 or higher) Surface RT or Pro tablet with networked Epson products. The Epson Print and Scan app allows you to scan and capture images right to your tablet or to Microsoft OneDrive.

**Note:** The Epson Print and Scan app does not support Windows 10 Mobile printing and does not supply scanning functions for products without scanners.

1. Connect your Epson product to your wireless network. See the link below.
2. Download the Epson Print and Scan app from the Microsoft Windows Store.
3. Connect your Windows tablet to the same wireless network as your product.
4. Open the Epson Print and Scan app and select your Epson product.

Now you are ready to print photos or scan.

**Parent topic:** [Product Basics](#)

### Related topics

[Wi-Fi or Wired Networking](#)

## Using the Mopria Print Service

You can use the Mopria Print Service to print from your Android phone or tablet (Android v4.4 or later) to your Epson product or any Mopria-certified product from other manufacturers. You can download the Mopria Print Service from Google Play.

**Note:** For details on the Mopria Print Service, [click here](#).

1. Connect your Epson product to your wireless network. See the link below.
2. On your Android device, download the Mopria Print Service app from Google Play.

**Note:** On some Samsung Galaxy devices, Mopria may come preinstalled.

3. Go to **Settings** on your Android device, select **Printing**, and enable the Mopria Print Service, if necessary.
4. Connect your Android device to the same wireless network as your product.
5. Now you are ready to print. From an Android application such as Chrome or Gmail, tap the menu icon and select **Print**. Then select **All printers**, select your Epson product, adjust your print settings, and print.

**Parent topic:** [Product Basics](#)

### **Related topics**

[Wi-Fi or Wired Networking](#)

---

# Wi-Fi or Wired Networking

See these sections to use your product on a Wi-Fi or wired network.

[Network Security Recommendations](#)

[Wi-Fi Infrastructure Mode Setup](#)

[Wi-Fi Direct Mode Setup](#)

[Wi-Fi Protected Setup \(WPS\)](#)

[Printing a Network Status Sheet](#)

[Printing a Network Connection Report](#)

[Changing or Updating Network Connections](#)

## Network Security Recommendations

To help deter unauthorized access to your product over a network, you should protect your network environment using appropriate security measures.

Security measures such as these can help deter threats such as loss of user data, use of telephone and fax lines, and other intrusions:

- **Enable security on your wireless LAN**

Enable the appropriate security on the wireless LAN you plan to use with your product. Network security such as a network password can deter interception of traffic over the wireless LAN. Your router may already have a default password enabled by your Internet service provider (ISP). See your ISP and router documentation for instructions on how to change the default password and better secure your network.

- **Connect your product only to a network protected by a firewall**

Connecting your product directly to the Internet may leave it vulnerable to security threats. Instead, connect it to a router or other network connection protected by a firewall. Your router may already have a firewall set up by your Internet service provider; check with your ISP for confirmation. For best results, set up and use a private IP address for your network connection.

- **Change the default administrator password on your product**

If your product has an option to set an administrator password, change the default administrator password to deter access by unauthorized users to personal data stored on your product, such as IDs, passwords, and contact lists.

**Parent topic:** [Wi-Fi or Wired Networking](#)

## Wi-Fi Infrastructure Mode Setup

You can set up your product to communicate with your computer using a wireless router or access point. The wireless router or access point can be connected to your computer over a wireless or wired network.

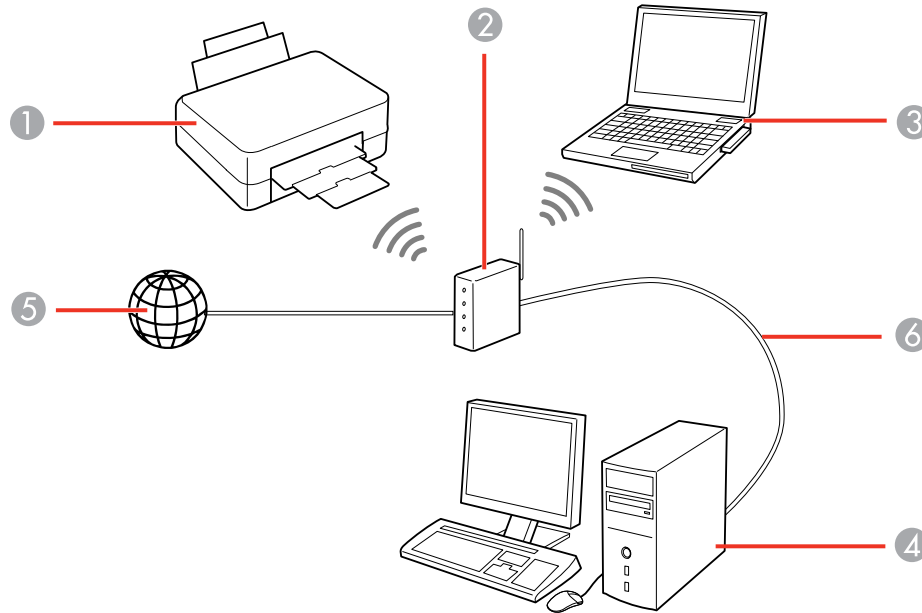

- 1 Epson product
- 2 Wireless router or access point
- 3 Computer with a wireless interface
- 4 Computer
- 5 Internet
- 6 Ethernet cable (used only for wired connection to the wireless router or access point)

[Selecting Wireless Network Settings from the Control Panel](#)  
[Setting Up Wireless Printing from a Smartphone or Tablet](#)

**Parent topic:** [Wi-Fi or Wired Networking](#)

## Selecting Wireless Network Settings from the Control Panel

You can select or change wireless network settings using your product control panel.

To install your product on a wireless network, follow the instructions on the *Start Here* sheet and install the necessary software by downloading it from the Epson website. The installer program guides you through network setup.

**Note:** Breakdown or repair of this product may cause loss of network data and settings. Epson is not responsible for backing up or recovering data and settings during or after the warranty period. We recommend that you make your own backup or print out your network data and settings.

1. Select the  home icon, if necessary.
2. Select the   icon.

You see a screen like this:

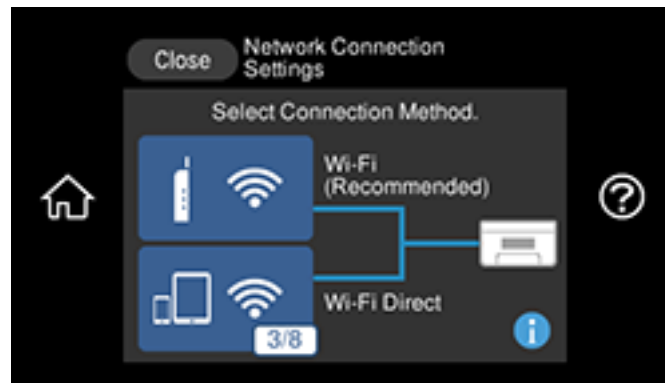





3. Select **Wi-Fi (Recommended)** (if the product is already installed on a wired network, select **Router**).
4. Select **Start Setup** or **Change Settings** (if the product is already installed on a wired network, select **Change to Wi-Fi connection** and select **Yes** to confirm).
5. Select **Wi-Fi Setup Wizard**.
6. Select the name of your wireless network or select **Enter Manually** to enter the name manually. Use the displayed keyboard to enter your network name.

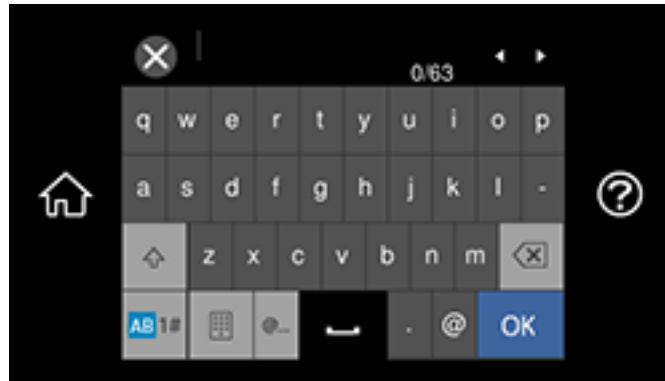

7. Select the **Enter Password** field and enter your wireless password using the on-screen keyboard.



**Note:** The network name and password are case sensitive. Be sure to correctly enter uppercase and lowercase letters, and numeric or special characters.

- To move the cursor, press the left or right arrows.
  - To change the case of letters, select .
  - To delete the previous character, select .
  - To enter numbers and symbols, select .
  - To enter a space, select .
8. Select **OK** when you finish entering your password.
  9. Confirm the displayed network settings and select **Start Setup** to save them.
  10. Do one of the following:
    - If setup was successful, select **Close** to exit.
    - If setup was unsuccessful, select **Print Check Report** to print a network setup report or select **Re-enter** to re-enter your network name and password.
  11. Select the  home icon to return to the Home screen.

The  Wi-Fi icon displayed on the LCD screen indicates your wireless connection status. If the product is not connected to the network, you may have selected the wrong network name (SSID) or entered the password incorrectly. Repeat these steps to try again.

If you are printing from a computer, make sure you installed the network software as described on the *Start Here* sheet.

**Parent topic:** [Wi-Fi Infrastructure Mode Setup](#)

**Related references**

[Status Icon Information](#)

**Related tasks**

[Entering Characters on the LCD Screen](#)

## Setting Up Wireless Printing from a Smartphone or Tablet

You can use the Epson Smart Panel app to connect your Epson product to a wireless network or connect your device directly to the product. Epson Smart Panel is available on iOS and Android devices.

Make sure you have the following:

- A Bluetooth-enabled device that is connected to a wireless network
- The Epson Smart Panel app installed on the device
- The wireless network name (SSID) and password

**Note:** Your device must be close enough to the product to create and maintain a Bluetooth connection.

1. Make sure the product is turned on and is ready to print.

**Note:** You must perform initial setup and ink installation before setting up wireless printing.

2. Open the Epson Smart Panel app on your device.
3. Do one of the following:
  - If the app automatically recognizes the product, follow the on-screen instructions to set up the wireless connection.
  - If the app does not automatically recognize the product, select the **+** icon and continue with the next step.

4. On the next screen, select **Start setting up** and follow the on-screen instructions.

**Note:** If your product is not listed, move closer to the product and try again. If the product is still not shown, connect your printer to the wireless network using the control panel and then select **Connect Smartphone to Product Already Connected to Wi-Fi** in the Epson Smart Panel app and follow the on-screen instructions. See the link below for wireless setup instructions.

Your product is now connected to a wireless network and set up for use with the Epson Smart Panel app.

**Parent topic:** [Wi-Fi Infrastructure Mode Setup](#)

**Related tasks**

[Using the Epson Smart Panel Mobile App](#)

## Wi-Fi Direct Mode Setup

You can set up your product to communicate directly with your computer or another device without requiring a wireless router or access point. In Wi-Fi Direct Mode, the product itself acts as a network access point for up to 8 devices.

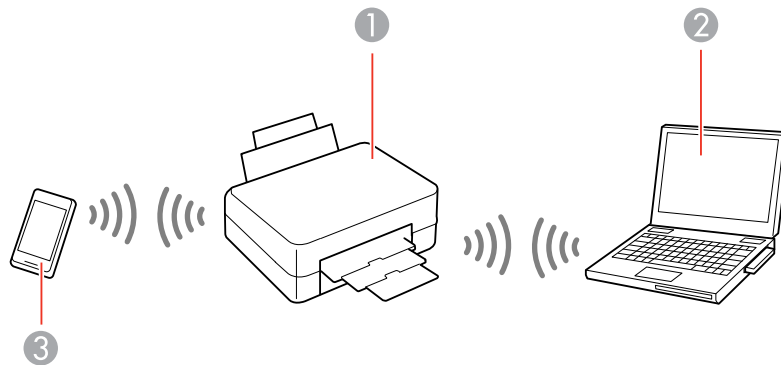

- 1 Epson product
- 2 Computer with a wireless interface
- 3 Other wireless device

[Enabling Wi-Fi Direct Mode \(Simple AP\)](#)

Parent topic: [Wi-Fi or Wired Networking](#)

## Enabling Wi-Fi Direct Mode (Simple AP)

You can enable Wi-Fi Direct mode to allow direct communication between your product and computer, mobile devices, or other devices (up to 8) without a wireless router or access point.

**Note:** Make sure the Epson Smart Panel app or another compatible Epson printing app is installed on your mobile device before connecting to the product.

1. Select the  home icon, if necessary.
2. Select **Smartphone connect**.
  - If your product is not connected to a wireless network, select **Start Setup**. The product information is displayed on the LCD screen. Open the compatible Epson printing app on your device and select your product. Select **Complete** on the LCD screen.
  - If your product is already connected to a wireless network, select **Other Methods** and go to the next step.
3. Select **Start Setup**.
4. Select **Other Methods**.

You see this screen:

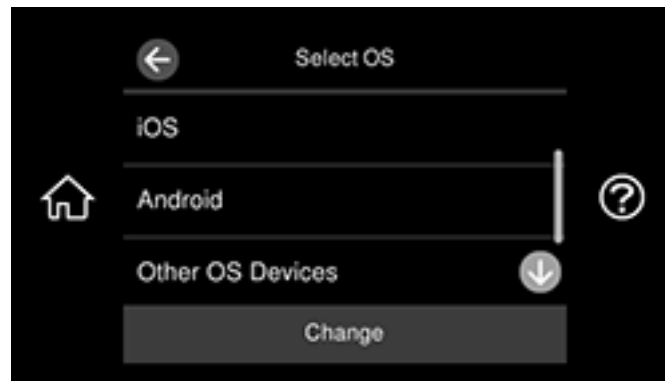

5. Do one of the following to complete Wi-Fi Direct setup:
  - For iOS devices, select **iOS**. Scan the QR code with the camera app on your device and follow the instructions on your device. Open the compatible Epson printing app on your device and select your product. Select **Complete** on the LCD screen.
  - For Android devices, select **Android**. Open the compatible Epson printing app on your device and select your product. Select **Complete** on the LCD screen.
  - For other types of devices, select **Other OS Devices**. Use your device to select the Wi-Fi network name (SSID) displayed on the LCD screen and enter the password shown. Follow the instructions on the LCD screen.

The  Wi-Fi Direct icon is displayed on the LCD screen and indicates if Wi-Fi Direct is enabled on the product.

**Parent topic:** [Wi-Fi Direct Mode Setup](#)

#### **Related references**

[Status Icon Information](#)

#### **Related tasks**

[Using the Epson Smart Panel Mobile App](#)

## **Wi-Fi Protected Setup (WPS)**

If your network uses a WPS-enabled wireless router or access point, you can quickly connect your product to the network using Wi-Fi Protected Setup (WPS).

**Note:** To check if your router is WPS-enabled, look for a button labeled **WPS** on your router or access point. If there is no hardware button, there may be a virtual WPS button in the software for the device. Check your network product documentation for details.

[Using WPS to Connect to a Network](#)

**Parent topic:** [Wi-Fi or Wired Networking](#)

## **Using WPS to Connect to a Network**

If you have a WPS-enabled wireless router or access point, you can use Wi-Fi Protected Setup (WPS) to connect your product to the network.

1. Select the  home icon, if necessary.
2. Select the   icon.

You see a screen like this:

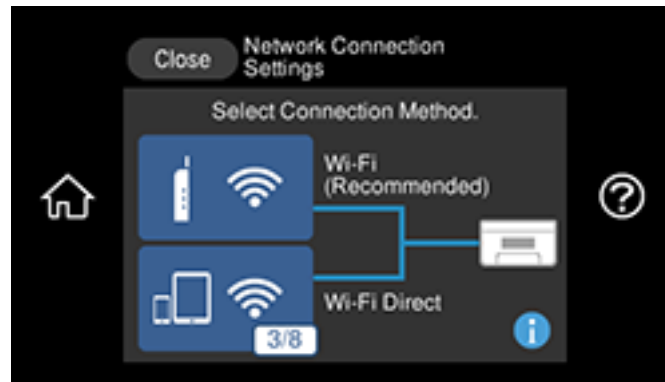

3. Select **Wi-Fi (Recommended)**.
4. Select **Start Setup** or **Change Settings**.
5. Select **Push Button Setup (WPS)**.
6. Follow the instructions on the LCD screen to complete WPS setup.

**Note:** Make sure you press **Start Setup** within two minutes of activating WPS on your router.

7. Select the  home icon to return to the Home screen.

The  Wi-Fi icon displayed on the LCD screen indicates your wireless connection status. If the product is not connected to the network, repeat these steps to try again.

If you are printing from a computer, make sure you installed the network software as described on the *Start Here* sheet.

Parent topic: [Wi-Fi Protected Setup \(WPS\)](#)

## Printing a Network Status Sheet

You can print a network status sheet to help you determine the causes of any problems you may have using your product on a network.

1. Make sure a few sheets of plain paper are loaded in the cassette.
2. Select the  home icon, if necessary.

3. Select **Settings** > **Network Settings** > **Network Status** > **Print Status Sheet**.

You see a screen like this:

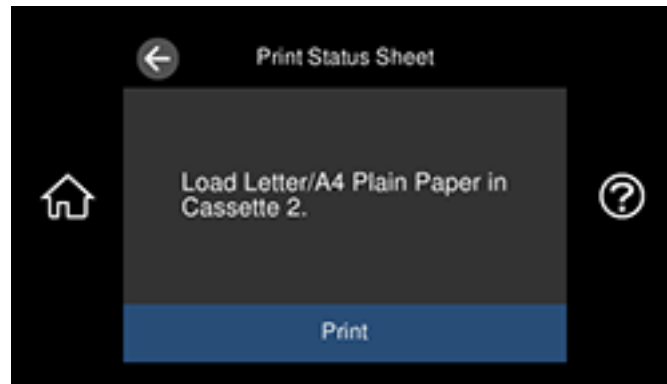

4. Select **Print**.

Examine the settings shown on the network status sheet to diagnose any problems you have.

**Parent topic:** [Wi-Fi or Wired Networking](#)

## Printing a Network Connection Report

You can print a network connection report to view solutions to any problems you may have using your product on a network.

1. Make sure a few sheets of plain paper are loaded in the lower cassette.
2. Select the  home icon, if necessary.
3. Select **Settings** > **Network Settings** > **Connection Check**.

You see a screen like this:

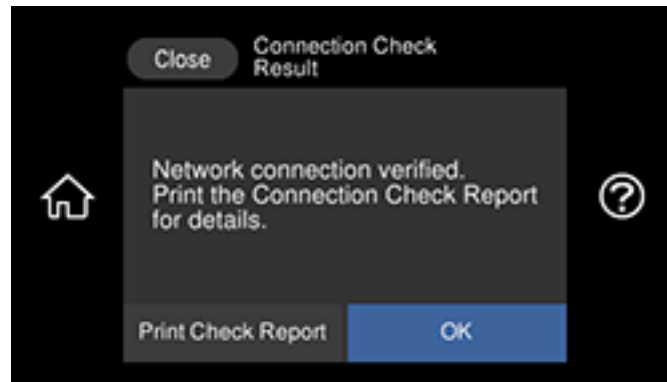

4. Select **Print Check Report** to print the network connection report.  
Examine any error codes and solutions shown on the network connection report.

[Network Connection Report Codes and Messages](#)

Parent topic: [Wi-Fi or Wired Networking](#)

## Network Connection Report Codes and Messages

Check the error codes and messages on the network connection report to solve problems you may encounter with network connections. The tables here list solutions to problems based on the error codes and messages that may appear on the top of the report.

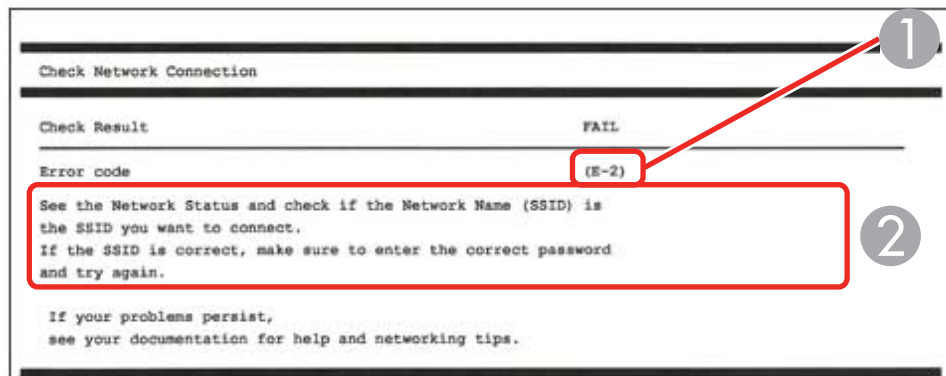



- 1 Error code
- 2 Message

**Note:** Error codes and messages listed here may not all apply to your product.

### **Error Codes and Messages**

<b>Error code and message</b>	<b>Solution</b>
<b>E-1</b> Confirm that the network cable is connected and network devices such as hub, router, or access point are turned on.	Make sure your router, access point, and/or hub are turned on, and the network cable is securely connected to your device and to your product. If you are trying to set up Wi-Fi, remove the network cable and set up Wi-Fi again. Ethernet and Wi-Fi cannot be connected at the same time.

Error code and message	Solution
<p><b>E-2, E-3, or E-7</b></p> <p>No wireless network names (SSID) found. Confirm that the router/access point is turned on and the wireless network (SSID) is set up correctly. Contact your network administrator for assistance.</p> <p>No wireless network names (SSID) found. Confirm that the wireless network name (SSID) of the PC you wish to connect is set up correctly. Contact your network administrator for assistance.</p> <p>Entered security key/password does not match the one set for your router/access point. Confirm security key/password. Contact your network administrator for assistance.</p>	<p>Check the following:</p> <ul style="list-style-type: none"> <li>• Make sure your router or access point is turned on, and is correctly connected to your computer or network device.</li> <li>• Turn off the router or access point, wait about 10 seconds, and turn it on again.</li> <li>• Move your product closer to your router or access point, and remove any obstacles between them. Also move your product away from devices such as wireless phones or microwaves.</li> <li>• Confirm that the SSID shown on the network connection report matches the label on your router or access point. Also make sure your SSID uses only ASCII characters and symbols, or your product cannot display the SSID correctly.</li> <li>• If you are trying to connect using the WPS push button method, make sure your router or access point supports it.</li> <li>• If you are using a network password, check the label on your router or access point to confirm that you are using the correct password, or check with your network administrator or router/access point documentation.</li> <li>• If you are connecting to a smart device that generates an SSID, check the device documentation for the SSID and password you should use.</li> <li>• If your wireless connection suddenly disconnects, and another smart device was added to the network using a WPS push button method or your network was set up using a non-WPS push button method, try downloading and installing your product software again.</li> </ul>

Error code and message	Solution
<p><b>E-5</b> Security mode (e.g. WEP, WPA) does not match the current setting of the printer. Confirm security mode. Contact your network administrator for assistance.</p>	<p>If the security on your router or access point is not one of the following types, change the type of security on your router or access point and reset your product's network settings.</p> <ul style="list-style-type: none"> <li>• WEP-64 bit (40 bit)</li> <li>• WEP-128 bit (104 bit)</li> <li>• WPA PSK (TKIP/AES); also known as WPA Personal</li> <li>• WPA2 PSK (TKIP/AES); also known as WPA2 Personal</li> <li>• WPA (TKIP/AES)</li> <li>• WPA2 (TKIP/AES)</li> <li>• WPA3-SAE (AES)</li> </ul>
<p><b>E-6</b> MAC address of your printer may be filtered. Check whether your router/access point has restrictions such as MAC address filtering. See the documentation of the router/access point or contact your network administrator for assistance.</p>	<p>If your router or access point has MAC address filtering enabled, register your product's MAC address so it is not filtered. Locate the MAC address on the network connection report and check your router or access point documentation for instructions.</p> <p>If your router or access point is using shared authentication with WEP security, confirm that you are using the correct authentication key and index.</p> <p>If your router or access point limits the number of connected devices, raise the connection limit. See your router or access point documentation for instructions.</p>
<p><b>E-8</b> Incorrect IP address is assigned to the printer. Confirm IP address setup of the network device (hub, router, or access point). Contact your network administrator for assistance.</p>	<p>If your product's <b>Obtain IP Address</b> setting is set to <b>Auto</b>, enable DHCP on your router or access point. If it is set to <b>Manual</b>, the IP address may be out of range or on a different network segment; set a valid IP address using your product control panel or the Web Config utility.</p> <p>You can also try turning off your product and the router or access point, waiting about 10 seconds, and turning them on again.</p>

Error code and message	Solution
<p><b>E-9</b></p> <p>Confirm the connection and network setup of the PC or other device. Connection using the EpsonNet Setup is available. Contact your network administrator for assistance.</p>	<p>Make sure your computer or network device are turned on. Also make sure that you can access the Internet and other devices on the same network from the devices you are trying to connect to your product.</p> <p>If you still cannot connect to your product, turn off your router or access point, wait about 10 seconds, and turn it on again. Download and install your product software again to reset your network settings.</p>
<p><b>E-10</b></p> <p>Confirm IP address, subnet mask, and default gateway setup. Connection using the EpsonNet Setup is available. Contact your network administrator for assistance.</p>	<p>Make sure other devices on the network are turned on and do the following:</p> <ul style="list-style-type: none"> <li>• If your product's <b>Obtain IP Address</b> setting is set to <b>Manual</b>, check the IP address, subnet mask, and default gateway addresses on the network connection report to see if they are correct. If not, correct the settings.</li> <li>• If DHCP is enabled, set your product's <b>Obtain IP Address</b> setting to <b>Auto</b>. If you want to use the DHCP-assigned address as a static address, set the <b>Obtain IP Address</b> setting to <b>Manual</b>, enter the product's IP address as listed on the network connection report, and set the subnet mask to 255.255.255.0.</li> </ul> <p>If you still cannot connect to your product, turn off your router or access point, wait about 10 seconds, and turn it on again.</p>
<p><b>E-11</b></p> <p>Setup is incomplete. Confirm default gateway setup. Connection using the EpsonNet Setup is available. Contact your network administrator for assistance.</p>	<p>If you set your product's <b>TCP/IP Setup</b> setting to <b>Manual</b>, check that the default gateway address listed on the network connection report is correct. Also turn on the device that is set as the default gateway.</p>

Error code and message	Solution
<p><b>E-12</b></p> <p>Confirm the following:</p> <ul style="list-style-type: none"> <li>-Entered security key/password is correct</li> <li>-Index of the security key/password is set to the first number</li> <li>-IP address, subnet mask, or default gateway setup is correct</li> </ul> <p>Contact your network administrator for assistance.</p>	<p>Make sure other devices on the network are turned on and do the following:</p> <ul style="list-style-type: none"> <li>• Make sure the IP address, subnet mask, and default gateway addresses are correct, if you are entering them manually.</li> <li>• Confirm that the subnet mask and default gateway addresses for other devices are the same.</li> <li>• Make sure the IP address does not conflict with other devices.</li> </ul> <p>If you still cannot connect to your product, do the following:</p> <ul style="list-style-type: none"> <li>• Turn off your router or access point, wait about 10 seconds, and turn it on again.</li> <li>• Download and install your product software again to reset your network settings.</li> <li>• If your router or access point uses WEP security with several registered passwords, make sure that the first registered password is set on your product.</li> </ul>
<p><b>E-13</b></p> <p>Confirm the following:</p> <ul style="list-style-type: none"> <li>-Entered security key/password is correct</li> <li>-Index of the security key/password is set to the first number</li> <li>-Connection and network setup of the PC or other device is correct</li> </ul> <p>Contact your network administrator for assistance.</p>	<p>Make sure your router, access point, and/or hub are turned on. Also make sure the TCP/IP setup on your router, access point, and/or hub is not set manually; this may cause your product's network settings to differ from the manually set up devices.</p> <p>If you still cannot connect to your product, do the following:</p> <ul style="list-style-type: none"> <li>• Turn off your router or access point, wait about 10 seconds, and turn it on again.</li> <li>• Download and install your product software again to reset your network settings.</li> <li>• If your router or access point uses WEP security with several registered passwords, make sure that the first registered password is set on your product.</li> </ul>

## Network Environment Messages

Message	Solution
The Wi-Fi environment needs to be improved. Turn the wireless router off and then turn it on. If the connection does not improve, see the documentation for the wireless router.	Move your product closer to your router or access point, and remove any obstacles between them. Then turn off your router or access point, wait about 10 seconds, and turn it back on again. If you still cannot connect to your product, check the documentation that came with your router or access point for solutions.
*No more devices can be connected. Disconnect one of the connected devices if you want to add another one.	You can connect up to 8 computers or other devices to your product using a Wi-Fi Direct (Simple AP) connection. If you want to add another device, disconnect an existing connected device first.
The same SSID as Wi-Fi Direct exists in the environment. Change the Wi-Fi Direct SSID if you cannot connect a smart device to the printer.	Change the Wi-Fi Direct SSID.

Parent topic: [Printing a Network Connection Report](#)

## Changing or Updating Network Connections

See these sections to change or update how your product connects to a network.

[Accessing the Web Config Utility](#)

[Changing a USB Connection to a Wi-Fi Connection](#)

[Changing a Wi-Fi Connection to a Wired Network Connection](#)

[Connecting to a New Wi-Fi Router](#)

[Disabling Wi-Fi Features](#)

Parent topic: [Wi-Fi or Wired Networking](#)

## Accessing the Web Config Utility

You can select your product's network settings and confirm its operating status using a web browser. You do this by accessing your product's built-in Web Config utility from a computer or other device that is connected to the same network as your product.

**Note:** You can also access the Web Config utility from the product information area in the Epson Smart Panel app.

1. Print a network status sheet.
2. Locate the IP address for your product that is listed on the network status sheet.
3. On a computer or other device connected to the same network as your product, open a web browser.
4. Enter your product's IP address into the address bar.

You see the available Web Config utility options.

**Parent topic:** [Changing or Updating Network Connections](#)

**Related tasks**

[Printing a Network Status Sheet](#)

## Changing a USB Connection to a Wi-Fi Connection

If you have already connected your product to your computer using a USB connection, you can change to a Wi-Fi connection.

1. Disconnect the USB cable from your product.
2. Uninstall your product software.
3. Download and install your product software from the Epson website using the instructions on the *Start Here* sheet.

**Parent topic:** [Changing or Updating Network Connections](#)

**Related concepts**

[Uninstall Your Product Software](#)

## Changing a Wi-Fi Connection to a Wired Network Connection

If you have already connected your product to your computer wirelessly, you can change to a wired network connection if necessary.

1. Disable your product's Wi-Fi features.
2. Connect one end of an Ethernet network cable to the product's **LAN** port.
3. Connect the other end to any available LAN port on your router or access point.
4. Uninstall your product software.

5. Download and install your product software from the Epson website.
6. Follow the on-screen instructions to install the software.
7. When you see the Select Your Connection screen, select **Wired network connection**.
8. If you see a Select Setup Option screen, select **Set up printer for the first time**.
9. Continue following the rest of the on-screen instructions.

**Parent topic:** [Changing or Updating Network Connections](#)

**Related concepts**

[Uninstall Your Product Software](#)

**Related tasks**

[Disabling Wi-Fi Features](#)

## Connecting to a New Wi-Fi Router

If you change the wireless router you have been using on your network, you need to update your product's Wi-Fi connection to the new router.

**Note:** If you switch to a 5 GHz wireless router, set the router to operate in dual band (2.4 GHz and 5 GHz) mode. If your router uses a single network name (SSID) for both the 2.4 GHz and 5 GHz band, give each band its own network name (SSID) instead, such as Home Network 2.4 GHz and Home Network 5 GHz. See your router documentation for instructions.

1. Do one of the following:
  - **Windows:** Uninstall your product software.
  - **Mac:** Go to the next step.
2. Download and install your product software from the Epson website using the instructions on the *Start Here* sheet.

**Parent topic:** [Changing or Updating Network Connections](#)

**Related concepts**



[Uninstall Your Product Software](#)

## Disabling Wi-Fi Features

You may need to disable your product's Wi-Fi features if you change your network connection type or need to solve a problem with your network connection.



**Note:** Before disabling Wi-Fi features, make a note of your product's SSID (network name) and password, and any network settings selected for the Epson Connect services you may use.

1. Select the  home icon, if necessary.
2. Select the  icon.

You see a screen like this:

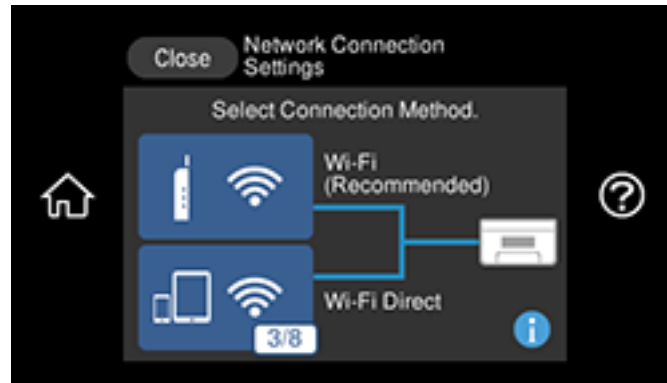

3. Select **Wi-Fi (Recommended)** > **Change Settings** > **Others** > **Disable Wi-Fi**.
4. Select **Start Setup** to disable Wi-Fi.
5. Select **Close**.

**Parent topic:** [Changing or Updating Network Connections](#)

**Related tasks**

[Printing a Network Status Sheet](#)

---

# Loading Paper

Before you print, load paper for the type of printing you will do.

[Loading Paper in Cassette 1 \(Upper Cassette\)](#)

[Loading Paper in Cassette 2 \(Lower Cassette\)](#)

[Loading Paper in the Rear of Your Product](#)

[Turning Off the Paper Mismatch Alert](#)

[Paper Loading Capacity](#)

[Double-sided Printing Capacity](#)

[Borderless Paper Type Compatibility](#)

[Compatible Epson Papers](#)

[Selecting the Paper Settings for Each Source - Control Panel](#)

[Paper or Media Type Settings - Printing Software](#)

## Loading Paper in Cassette 1 (Upper Cassette)

You can load photo paper and other media in these sizes in the upper cassette:

- 4 × 6 inches (102 × 152 mm)
- 5 × 7 inches (127 × 178 mm)
- A6 (4.1 × 5.8 inches [105 × 148 mm])

**Note:** Do not remove or insert the paper cassette while the product is operating.

1. Close the output tray by selecting **Output Tray** on the Home screen, if necessary.

2. Open the front cover.

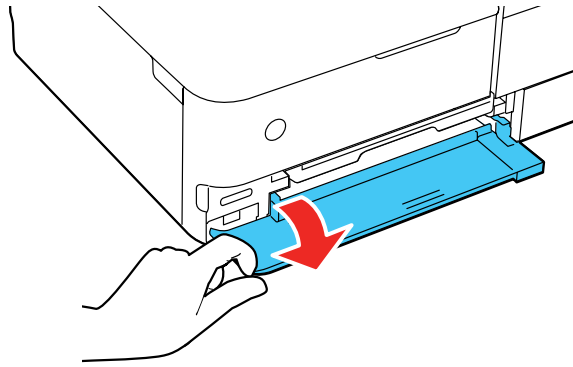

3. Pull out the upper cassette (labeled 1 on the cassette).

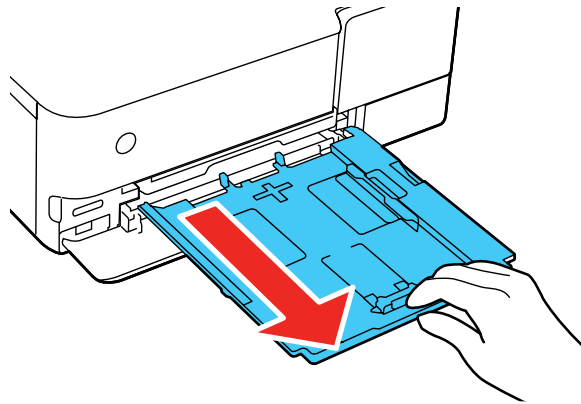

**Note:** If the cassette is too far inside the product to reach, turn the product off and on again to reset the cassette's position.

4. Slide the edge guides out.

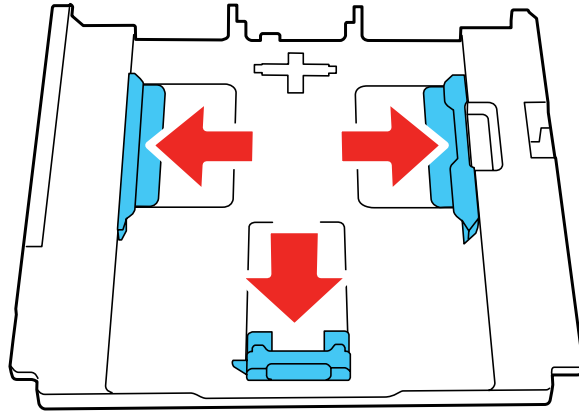

5. Insert paper in the cassette with the glossy or printable side facedown.

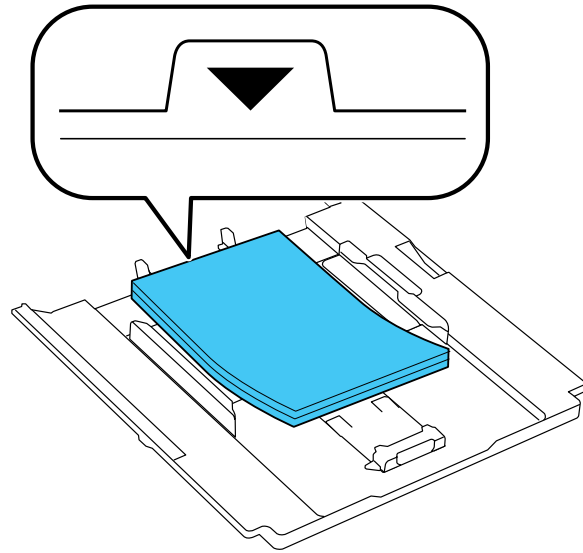

**Note:** Make sure the paper does not extend beyond the triangle symbol at the rear edge of the cassette.

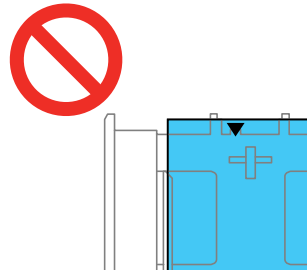

6. Slide the side edge guides against the paper, but not too tightly.

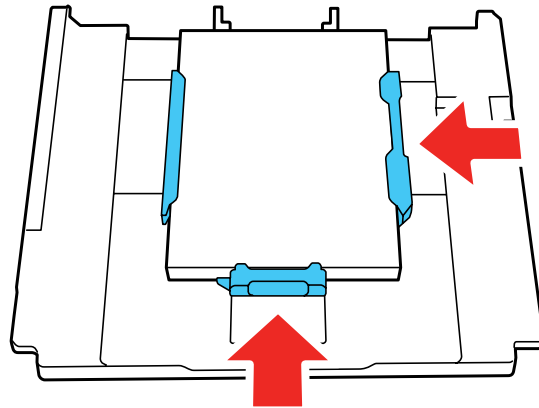

**Note:** Make sure the paper fits under the tabs on the edge guides.

7. Keeping the cassette flat, slide it into your product.

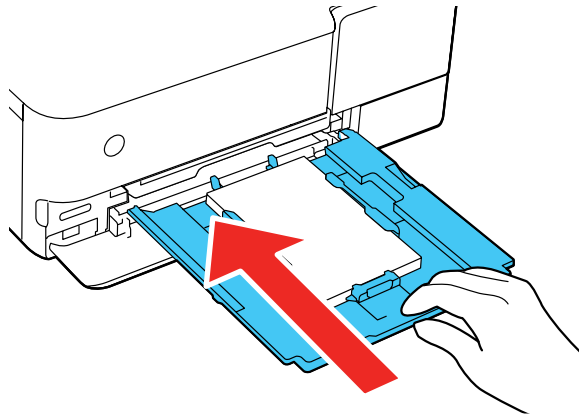

**Note:** If you slide the cassette too far into the product, turn the product off and on again. The cassette moves to the correct position.

8. Select the size and type of the paper you loaded on the LCD screen, and select **Close**.

**Note:** You can quickly select frequently used paper settings by selecting **Favorite Paper Settings**.

Keep the front cover open so the output tray can automatically extend after you send a print job. After printing, select **Output Tray** on the Home screen to close the output tray.

Always follow these paper loading guidelines:

- Load only the recommended number of sheets.
- Fan and align the edges of the paper before loading. Do not fan or curl photo paper. Doing so may damage the printable side.
- If paper is curled, flatten it or curl it slightly in the opposite direction before loading. Printing on curled paper may cause paper jams and smeared printouts.
- Do not load different types of paper in the cassette.
- Load paper short edge first and printable side facedown.
- Make sure the paper is under the tabs on the edge guides and not sticking out past the triangle symbol at the end of the cassette.
- Check the paper package for any additional loading instructions.

**Parent topic:** [Loading Paper](#)

**Related references**

[Double-sided Printing Capacity](#)

[Paper Loading Capacity](#)

**Related tasks**

[Loading Paper in Cassette 2 \(Lower Cassette\)](#)

[Loading Paper in the Rear of Your Product](#)

[Selecting the Paper Settings for Each Source - Control Panel](#)

## Loading Paper in Cassette 2 (Lower Cassette)

You can load envelopes and paper up to this size in the lower cassette: Letter (8.5 × 11 inches [216 × 279 mm]). For larger paper sizes, use the rear paper feeder or the rear paper feed slot.

**Note:** Do not remove or insert the paper cassette while the product is operating.

1. Close the output tray by selecting **Output Tray** on the Home screen, if necessary.
2. Open the front cover.

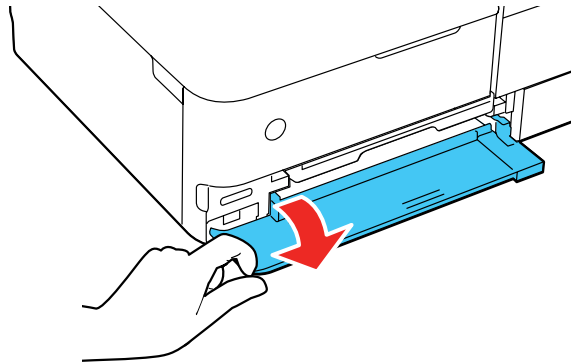

3. Pull on the front cover to slide out the lower cassette.

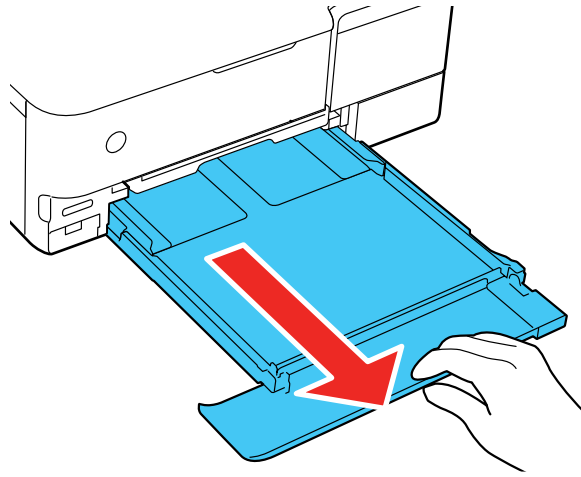

4. Slide the edge guides out.

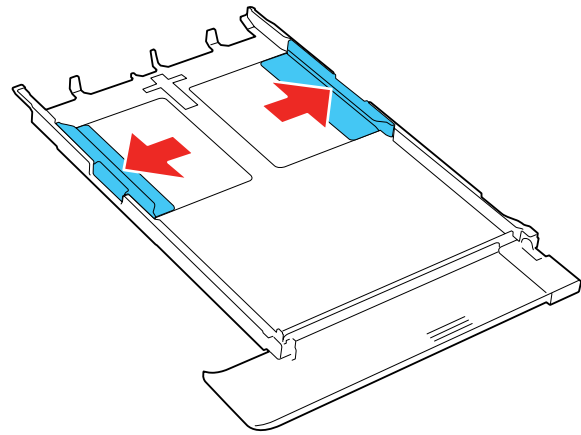



5. Do one of the following:

- Insert paper with the glossy or printable side facedown.

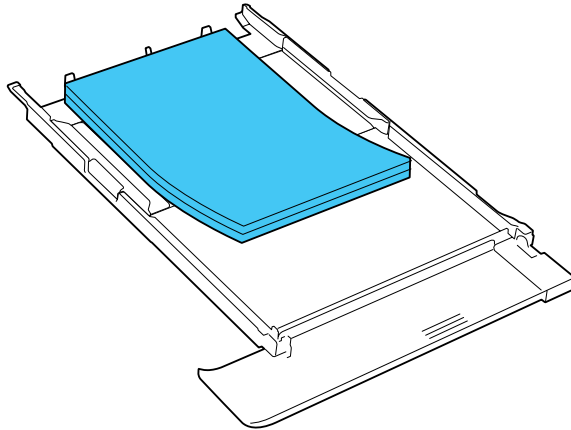

- Insert up to 10 envelopes, printable side down and flap edge left, as shown.

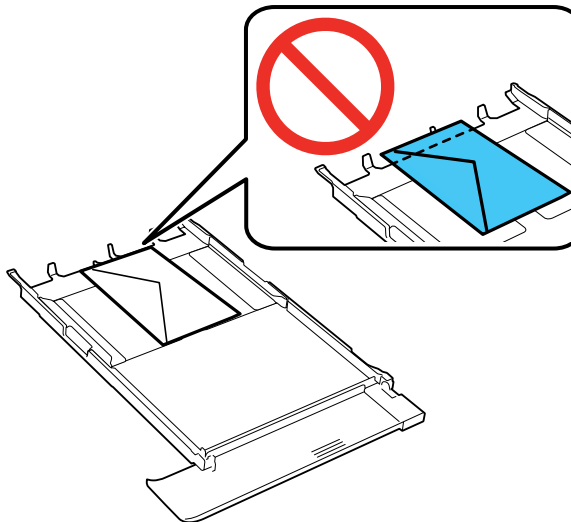

6. Slide the edge guides against the paper, but not too tightly.

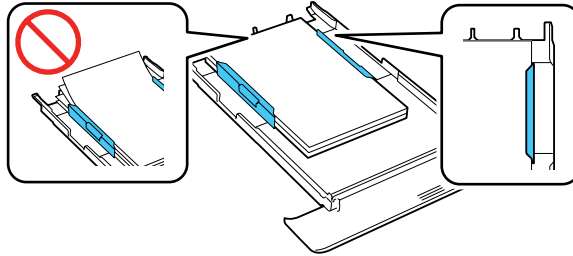

**Note:** Make sure the paper fits under the tabs on the edge guides.

7. Keep the cassette flat as you slide it into your product.

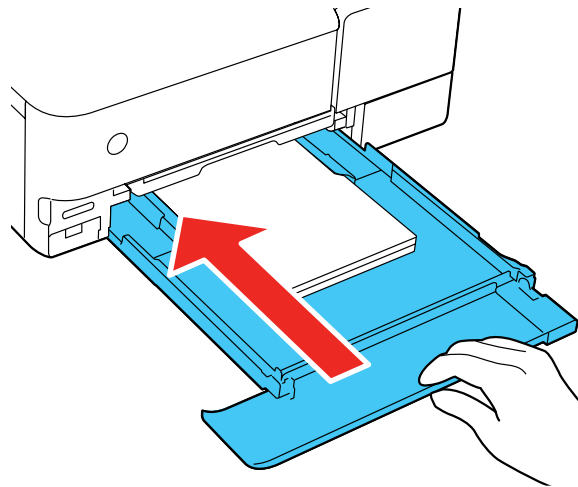

8. Select the size and type of paper you loaded on the LCD screen, and select **Close**.

**Note:** You can quickly select frequently used paper settings by selecting **Favorite Paper Settings**.

Keep the front cover open so the output tray can automatically extend after you send a print job. After printing, select **Output Tray** on the Home screen to close the output tray.

Always follow these paper loading guidelines:

- Load only the recommended number of sheets or envelopes.
- Fan and align the edges of the paper before loading. Do not fan or curl photo paper. Doing so may damage the printable side.
- Fan and align the edges of envelopes, and flatten stacks before loading.
- If paper is curled, flatten it or curl it slightly in the opposite direction before loading. Printing on curled paper may cause paper jams and smeared printouts.
- Do not load different types of paper in the cassette.
- Load paper short edge first and printable side facedown.
- Load envelopes printable side facedown and flap edge left.
- Make sure the paper is under the tabs on the edge guides.
- If you have trouble loading a stack of envelopes, press each envelope flat before loading it or load one envelope at a time.
- Do not load an envelope that is curled, folded, or too thin, or that has a plastic window.
- If print quality declines when printing multiple envelopes, try loading one envelope at a time.
- Check the paper package for any additional loading instructions.

**Parent topic:** [Loading Paper](#)

**Related references**

[Double-sided Printing Capacity](#)

[Paper Loading Capacity](#)

**Related tasks**

[Loading Paper in Cassette 1 \(Upper Cassette\)](#)

[Loading Paper in the Rear of Your Product](#)

[Selecting the Paper Settings for Each Source - Control Panel](#)

## Loading Paper in the Rear of Your Product

You can load paper in a variety of types and sizes using the rear paper feeder. You can also load one sheet of long or specialty paper in the rear paper feed slot in the back of the product.

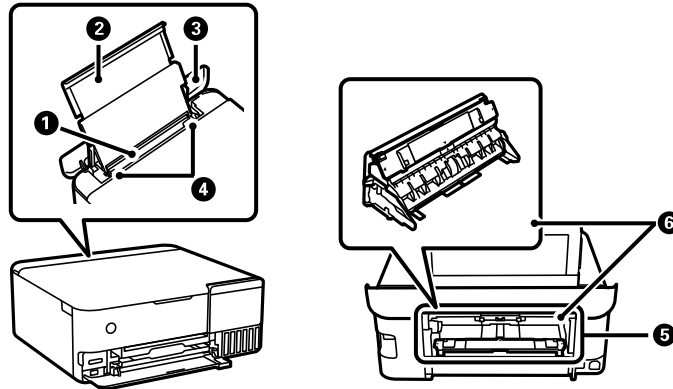

- 1 Rear paper feeder
- 2 Rear paper support
- 3 Rear paper feeder cover
- 4 Edge guides
- 5 Rear paper feed slot
- 6 Paper feed unit

**Note:** Do not load paper in the rear paper feed slot until prompted to do so. Otherwise, the blank paper will be ejected.

You can view instructions on how to load paper in the rear paper feeder or the rear paper feed slot on the control panel.

1. Select the  icon on the LCD screen.

You see this screen:

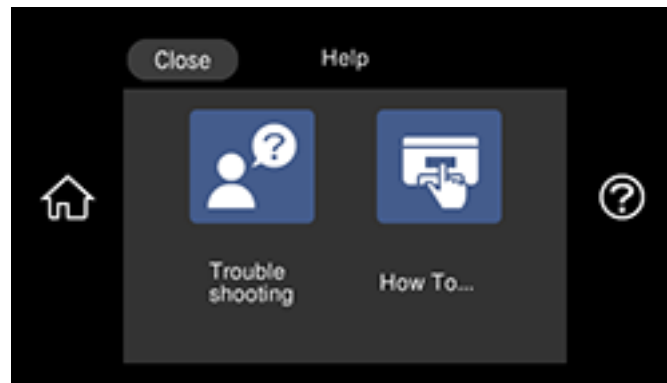

2. Select **How To**.



3. Select **Load paper**.

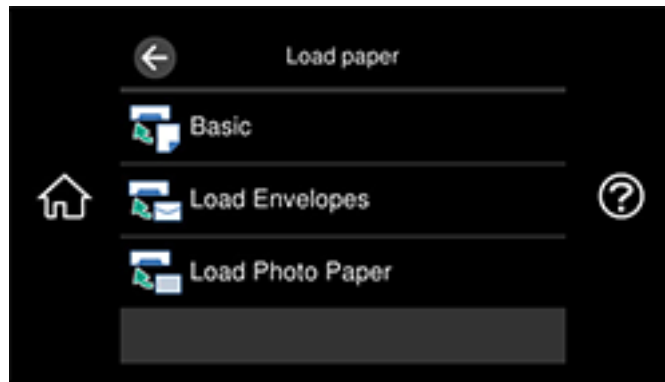

4. Select one of the options.



5. Select **Rear Paper Feeder** or **Rear Paper Feed Slot**, depending on your print job.



6. Select the  icon to scroll through the paper loading instructions.

Always follow these paper loading guidelines:

- Load only the recommended number of sheets.
- Load paper short edge first, no matter which way your document faces.
- Load the printable side faceup.
- Load letterhead or pre-printed paper top edge first.
- Check the paper package for any additional loading instructions.

**Caution:** Do not use the following papers. Using these papers may cause paper jams, smears on the printout, or damage to the printer.

- Papers that are wavy or damp
- Papers that have not dried after printing on one side
- Papers that are wadded or curled
- Papers that are torn, cut, or folded
- Papers that are too thick or thin
- Preprinted papers printed by other inkjet printers, thermal transfer printers, page printers, or copiers
- Papers that are perforated
- Papers that have stickers

- Papers held together with tape, staples, or paper clips
- Envelopes with adhesive surfaces or windows
- Pre-punched papers

**Parent topic:** [Loading Paper](#)

**Related references**

[Double-sided Printing Capacity](#)

[Paper Loading Capacity](#)

**Related tasks**

[Loading Paper in Cassette 1 \(Upper Cassette\)](#)

[Loading Paper in Cassette 2 \(Lower Cassette\)](#)

[Selecting the Paper Settings for Each Source - Control Panel](#)

## Turning Off the Paper Mismatch Alert

The Paper Mismatch alert warns you when the paper settings do not match the paper you loaded. You can turn off this feature from the product's control panel.

1. Select the  home icon, if necessary.
2. Select **Settings** > **Guide Functions** > **Paper Mismatch**.

You see a screen like this:

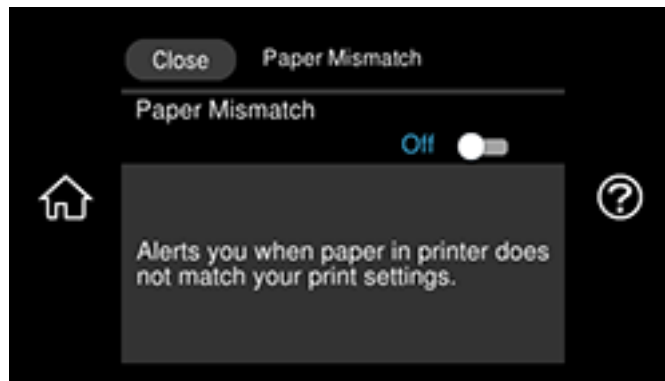

3. Set the **Paper Mismatch** setting to **Off**.



4. Select **Close** to exit.

**Parent topic:** [Loading Paper](#)

## Paper Loading Capacity

See the table here for the loading capacity of the paper cassettes and rear paper feeder.

For the rear paper feed slot, you can load one sheet of paper or one envelope at a time. For thick paper or card stock (0.61 to 1.3 mm), you can load one sheet in the following sizes:

- Legal (8.5 × 14 inches [216 × 356 mm])
- Letter (8.5 × 11 inches [216 × 279 mm])
- Mexico-Oficio (8.5 × 13.4 inches [216 × 340 mm])
- 8.5 × 13 inches (216 × 330 mm)
- Oficio 9 (8.46 × 12.4 inches [215 × 315 mm])
- A4 (8.3 × 11.7 inches [210 × 297 mm])
- Executive (7.25 × 10.5 inches [184 × 267 mm])
- 11 × 14 inches (279 × 356 mm)\*
- 11 × 17 inches (279 × 432 mm)\*
- A3 (11.7 × 16.5 inches [297 × 420 mm])\*
- A3+ (13 × 19 inches [329 × 483 mm])\*

\*L8180 only

### Standard Paper Capacity

Paper type	Paper size	Loading capacity		
		Cassette 1 (upper)	Cassette 2 (lower)	Rear paper feeder
Plain paper Letterhead paper	A4 (8.3 × 11.7 inches [210 × 297 mm]), Letter (8.5 × 11 inches [216 × 279 mm]), Executive (7.25 × 10.5 inches [184 × 267 mm]), Half Letter (5.5 × 8.5 inches [140 × 216 mm])	—	100 sheets	50 sheets
	A6 (4.1 × 5.8 inches [105 × 148 mm])	20 sheets	100 sheets	50 sheets
	Legal (8.5 × 14 inches [216 × 356 mm])	—	—	50 sheets
	<b>L8180:</b> 11 × 17 inches (279 × 432 mm), A3 (11.7 × 16.5 inches [297 × 420 mm]), A3+ (13 × 19 inches [329 × 483 mm])	—	—	50 sheets
Envelopes	#10	10	—	10 envelopes

### Epson Paper Capacity

Paper type	Loading capacity		
	Cassette 1 (upper)	Cassette 2 (lower)	Rear paper feeder
Epson Bright White Premium Paper	—	100 sheets	40 sheets
Epson Bright White Pro Paper	—	100 sheets	40 sheets

Paper type	Loading capacity		
	Cassette 1 (upper)	Cassette 2 (lower)	Rear paper feeder
Epson High Quality Ink Jet Paper	—	100 sheets	40 sheets
Epson Presentation Paper Matte	—	100 sheets	40 sheets*
Epson Premium Presentation Paper Matte	—	20 sheets	20 sheets*
Epson Premium Photo Paper Glossy Epson Premium Photo Paper Semi-gloss Epson Photo Paper Glossy	20 sheets	20 sheets	20 sheets*
Epson Ultra Premium Photo Paper Glossy	20 sheets	20 sheets	20 sheets
Epson Ultra Premium Photo Paper Luster	—	20 sheets	20 sheets
Epson Velvet Fine Art Paper	—	—	1 sheet

\*L8180: only 5 sheets at a time for paper sizes A3 (11.7 × 16.5 inches [297 × 420 mm]) and A3+ (13 × 19 inches [329 × 483 mm]).

**Parent topic:** [Loading Paper](#)

**Related references**

[Paper Specifications](#)

[Double-sided Printing Capacity](#)

## Double-sided Printing Capacity

You can print double-sided on the following paper types and sizes.

**Note:** Borderless printing is not available for double-sided printing. You cannot print double-sided from Cassette 1 (upper) or the rear paper feed slot. Manual double-sided printing is only available if Epson Status Monitor 3 is enabled.

Paper type	Size	Manual double-sided printing capacity	
		Cassette 2 (lower)	Rear paper feeder
Plain paper Letterhead paper	Letter (8.5 × 11 inches [216 × 279 mm]) A4 (8.3 × 11.7 inches [210 × 297 mm]) A6 (4.1 × 5.8 inches [105 × 148 mm]) Half Letter (5.5 × 8.5 inches [140 × 216 mm]) Executive (7.25 × 10.5 inches [184 × 267 mm])	30 sheets	20 sheets
Epson Bright White Premium Paper Epson Bright White Pro Paper	Letter (8.5 × 11 inches [216 × 279 mm])	30 sheets	20 sheets

**Parent topic:** [Loading Paper](#)

**Related references**

[Paper Loading Capacity](#)

## Borderless Paper Type Compatibility

You can print borderless photos on compatible paper types in compatible sizes:

### Borderless Paper Types

- Plain paper
- Letterhead paper
- Epson Bright White Premium Paper
- Epson Bright White Pro Paper

- Epson High Quality Ink Jet Paper
- Epson Presentation Paper Matte
- Epson Photo Paper Glossy
- Epson Premium Photo Paper Glossy
- Epson Ultra Premium Photo Paper Glossy
- Epson Premium Photo Paper Semi-gloss
- Epson Premium Presentation Paper Matte
- Epson Ultra Premium Photo Paper Luster
- Epson Velvet Fine Art Paper

#### **Borderless Paper Sizes**

- 4 × 6 inches (102 × 152 mm)
- 5 × 7 inches (127 × 178 mm)
- 8 × 10 inches (203 × 254 mm)
- Legal (8.5 × 14 inches [216 × 356 mm])
- Letter (8.5 × 11 inches [216 × 279 mm])
- A4 (8.3 × 11.7 inches [210 × 297 mm])
- 11 × 14 inches (279 × 356 mm)\*
- 11 × 17 inches (279 × 432 mm)\*
- A3 (11.7 × 16.5 inches [297 × 420 mm])\*
- A3+ (13 × 19 inches [329 × 483 mm])\*

\*L8180 only

**Parent topic:** [Loading Paper](#)

#### **Related references**

[Printable Area Specifications](#)

## **Compatible Epson Papers**

You can purchase genuine Epson ink, maintenance boxes, and paper from an Epson authorized reseller. To find the nearest reseller, visit [latin.epson.com](http://latin.epson.com) or call your nearest Epson sales office.

**Note:** Paper/media availability varies by country.

<b>Paper Type</b>	<b>Size</b>	<b>Part number</b>	<b>Sheet count</b>
Epson Bright White Premium Paper	Letter (8.5 × 11 inches [216 × 279 mm])	S450218-4	500
Epson Bright White Pro Paper	Letter (8.5 × 11 inches [216 × 279 mm])	S041586	500
Epson High Quality Ink Jet Paper	A4 (8.3 × 11.7 inches [210 × 297 mm])	S041117	100
	Letter (8.5 × 11 inches [216 × 279 mm])	S041111	100
Epson Presentation Paper Matte	Letter (8.5 × 11 inches [216 × 279 mm])	S041062	100
	Legal (8.5 × 14 inches [216 × 356 mm])*	S041067	100
	11 × 17 inches (279 × 432 mm)*	S041070	100
	A3+ (13 × 19 inches [329 × 483 mm])*	S041069-L	100
Epson Premium Presentation Paper Matte	8 × 10 inches (203 × 254 mm)	S041467	50
	Letter (8.5 × 11 inches [216 × 279 mm])	S041257	50
		S042180	100
	11 × 14 inches (279 × 356 mm)*	S041468	50
A3 (11.7 × 16.5 inches [297 × 420 mm])*	S041260	50	
Epson Photo Paper Glossy	Letter (8.5 × 11 inches [216 × 279 mm])	S041141	20
		S041649	50
		S041271	100
	11 × 17 inches (279 × 432 mm)*	S041156	20

Paper Type	Size	Part number	Sheet count
Epson Premium Photo Paper Glossy	4 × 6 inches (102 × 152 mm)	S041727	100
	5 × 7 inches (127 × 178 mm)	S041464	20
	8 × 10 inches (203 × 254 mm)	S041465	20
	Letter (8.5 × 11 inches [216 × 279 mm])	S042183	25
		S041667	50
	11 × 14 inches (279 × 356 mm)*	S041466	20
	11 × 17 inches (279 × 432 mm)*	S041290	20
	A3 (11.7 × 16.5 inches [297 × 420 mm])*	S041288	20
A3+ (13 × 19 inches [329 × 483 mm])*	S041289	20	
Epson Ultra Premium Photo Paper Glossy	4 × 6 inches (102 × 152 mm)	S042181	60
		S042174	100
	5 × 7 inches (127 × 178 mm)	S041945	20
	8 × 10 inches (203 × 254 mm)	S041946	20
	Letter (8.5 × 11 inches [216 × 279 mm])	S042182	25
S042175		50	
Epson Premium Photo Paper Semi-gloss	4 × 6 inches (102 × 152 mm)	S041982	40
	Letter (8.5 × 11 inches [216 × 279 mm])	S041331	20
Epson Ultra Premium Photo Paper Luster	Letter (8.5 × 11 inches [216 × 279 mm])	S041405	50
		S041913	250
	A3 (11.7 × 16.5 inches [297 × 420 mm])*	S041406	50
Epson Velvet Fine Art Paper	Letter (8.5 × 11 inches [216 × 279 mm])	S041636	20

\*L8180 only

Parent topic: [Loading Paper](#)

## Selecting the Paper Settings for Each Source - Control Panel

You can change the default paper size and paper type for each source using the control panel on the product.

1. Select the  home icon, if necessary.
2. Select **Settings** > **Printer Settings** > **Paper Source Setting**.

You see a screen like this:

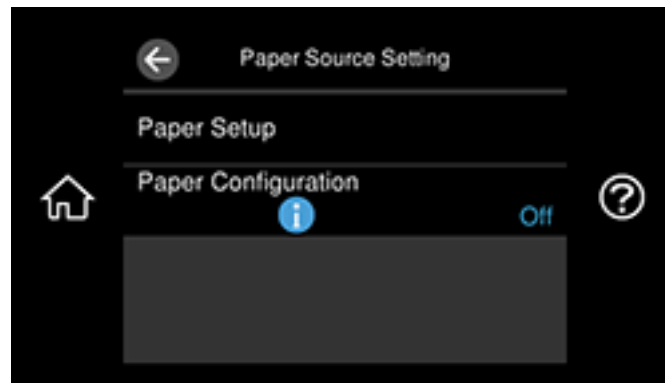



**Note:** To turn off the automatic display of the paper settings selection screen after paper is loaded in the cassettes, set the **Paper Configuration** setting to **Off** (AirPrint is disabled in this setting).

3. Select **Paper Setup**.
4. Select the paper source you want to change.
5. Select **Paper Size**.
6. Select the paper size you loaded.
7. Select **Paper Type**.



8. Select the paper type you loaded.

**Note:** To save a preset paper type, select the **Favorite Paper Settings** icon and specify the paper size and type.

9. Select  to select another paper source to change, or select the  home icon to exit.

[Paper or Media Type Settings - Control Panel](#)

Parent topic: [Loading Paper](#)

## Paper or Media Type Settings - Control Panel

For this paper	Select this Paper Type setting
Plain paper	<b>Plain Paper</b>
Letterhead paper	<b>Letterhead</b>
Epson Bright White Premium Paper	
Epson Bright White Pro Paper	
Epson Ultra Premium Photo Paper Glossy	<b>Ultra Glossy</b>
Epson Velvet Fine Art Paper	
Epson Premium Photo Paper Glossy	<b>Prem. Glossy</b>
Epson Photo Paper Glossy	<b>Glossy</b>
Epson Presentation Paper Matte	<b>Presentation Matte</b>
Epson Premium Photo Paper Semi-gloss	<b>Prem. Semi-Gloss</b>
Epson Ultra Premium Photo Paper Luster	<b>Ultra Prem. Photo Luster</b>
Epson Premium Presentation Paper Matte	<b>Prem. Matte</b>
Envelopes	<b>Envelope</b>
Epson Velvet Fine Art Paper	<b>Velvet Fine Art Paper</b>
Thin paper	<b>Thin paper</b>

Parent topic: [Selecting the Paper Settings for Each Source - Control Panel](#)

## Paper or Media Type Settings - Printing Software

For this paper	Select this paper Type or Media Type setting
Plain paper Letterhead paper Epson Bright White Premium Paper Epson Bright White Pro Paper	Plain Paper/Bright White Paper Letterhead
Epson Ultra Premium Photo Paper Glossy Epson Velvet Fine Art Paper	Ultra Premium Photo Paper Glossy
Epson Premium Photo Paper Glossy	Premium Photo Paper Glossy
Epson Photo Paper Glossy	Photo Paper Glossy
Epson Presentation Paper Matte	Presentation Paper Matte
Epson Premium Photo Paper Semi-gloss	Premium Photo Paper Semi-Gloss
Epson Ultra Premium Photo Paper Luster	Ultra Premium Photo Paper Luster
Epson Premium Presentation Paper Matte	Premium Presentation Paper Matte
Envelopes	Envelope
Epson Velvet Fine Art Paper	Velvet Fine Art Paper
Thin paper	Thin Paper
Thick paper or card stock between 0.024 to 0.031 inch (0.61 and 0.79 mm)	Card Stock 1 (0.024 - 0.031 in)
Thick paper or card stock between 0.032 to 0.051 inch (0.8 and 1.3 mm)	Card Stock 2 (0.032 - 0.051 in)

**Note:** The settings listed here are available only when printing from your computer; they do not apply to your product's control panel settings.

**Parent topic:** [Loading Paper](#)

---

## Placing Originals on the Product

Follow the instructions here to place your original documents or photos on the product.

**Caution:** Do not place anything on top of your product or use its cover as a writing surface to avoid damaging it.

[Placing Originals on the Scanner Glass](#)

## Placing Originals on the Scanner Glass

You can place originals up to this size on the scanner glass: Letter (8.5 × 11 inches [216 × 279 mm]) or A4 (8.3 × 11.7 inches [210 × 297 mm]) for the L8160 or Legal (8.5 × 14 inches [216 × 356 mm]) for the L8180.

**Note:** To view animated instructions on how to place originals on the scanner glass, select the  icon and select **How To > Place Originals**.

1. Open the document cover.

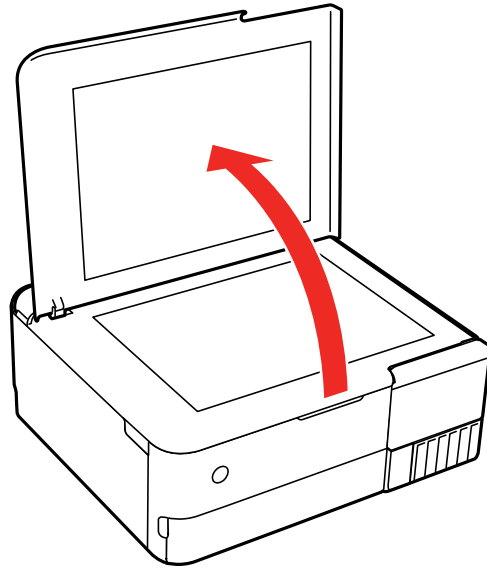

2. Place your original facedown on the scanner glass with the top facing into the corner. Slide the original to the edges of the indicated corner.

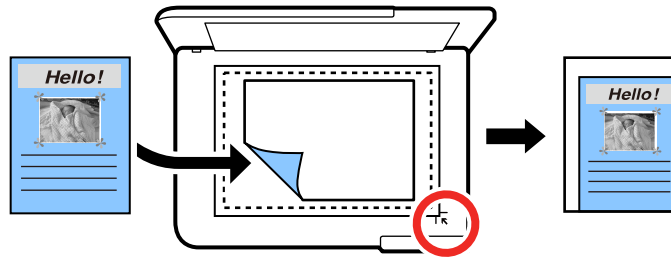

**Note:** The edges of your original may be cropped by 0.06 inch (1.5 mm) from the edge of the scanner glass. Manually position your original away from the edges to prevent cropping.

3. Close the document cover gently to keep your original in place.

**Caution:** Do not push down on the document cover or scanner glass or you may damage the product.

Remove your originals after scanning. If you leave the originals on the scanner glass for a long time, they may stick to the glass surface.

**Parent topic:** [Placing Originals on the Product](#)

**Related topics**

[Copying](#)

[Scanning](#)

---

# Copying

See the information here to copy documents or photos using your product.

**Note:** Copies may not be exactly the same size as your originals.

[Copying Documents or Photos](#)

[Restoring Photos While Copying](#)

[Copying Books, ID Cards, or Borderless Photos](#)

[Copying Options](#)

## Copying Documents or Photos

You can copy documents or photos onto various sizes and types of paper, including Epson special papers.

1. Place your original document or photo on the scanner glass.
2. Load the paper you want to print on.
3. Select the  home icon, if necessary.
4. Select **Copy**.

You see a screen like this:



5. To print more than one copy, select **Copies** and use the displayed numeric keypad to select the number of copies (up to 99).
6. Change any of the displayed settings as necessary.
7. Select the **Advanced Settings** tab to view and change additional copy settings, if necessary.
8. Select **Preview** to preview your copy on the LCD screen.
9. When you are ready to copy, select **Start Copy** or select the **Copy** icon.

**Note:** To cancel copying, select **Cancel**.

**Parent topic:** [Copying](#)

**Related references**

[Compatible Epson Papers](#)

[Copying Options](#)

**Related topics**

[Loading Paper](#)

[Placing Originals on the Product](#)

## Restoring Photos While Copying

You can restore the colors in faded photos as you copy them.

1. Load the paper you want to print on.
2. Select the  home icon, if necessary.
3. Select **Various Prints** > **Various copies**.

You see a screen like this:

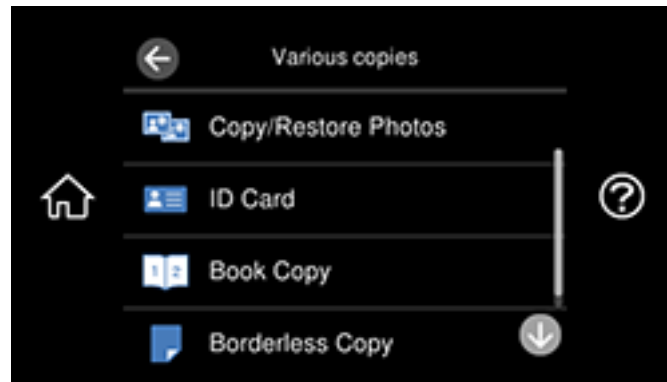

4. Select **Copy/Restore Photos**.
5. Make sure the **Restore Color** setting is set to **On**.
6. Select your other paper and print settings as necessary, then select **To Placing Originals**.
7. Place your original photos on the scanner glass.
8. Select **Start Scanning**.  
Your originals are scanned and a preview with restored colors appears on the LCD screen.
9. If you need to edit the copy, select **Edit** and change any of these settings as necessary:
  - **Photo Adjustments**: Select **Fix Photo On** to improve the color, contrast, and sharpness of flawed photos.
  - **Filter**: Select **B&W** to apply a monochrome filter.
  - **Crop/Zoom**: Zoom in to enlarge a part of the photo and crop it.
10. To print more than one copy, select **photo(s)** and use the displayed numeric keypad to select the number of copies (up to 99).
11. When you are ready to copy, select the **Copy** icon.

**Note:** To cancel printing, select **Cancel**.

**Parent topic:** [Copying](#)



### Related references

[Compatible Epson Papers](#)  
[Copying Options](#)

### Related topics

[Loading Paper](#)  
[Placing Originals on the Product](#)

## Copying Books, ID Cards, or Borderless Photos

You can copy two pages of a book or both sides of an ID card onto a single sheet of paper. You can also copy a photo and print it without any borders.

1. Load the paper you want to print on.
2. Select the  home icon, if necessary.
3. Select **Various Prints** > **Various copies**.

You see a screen like this:

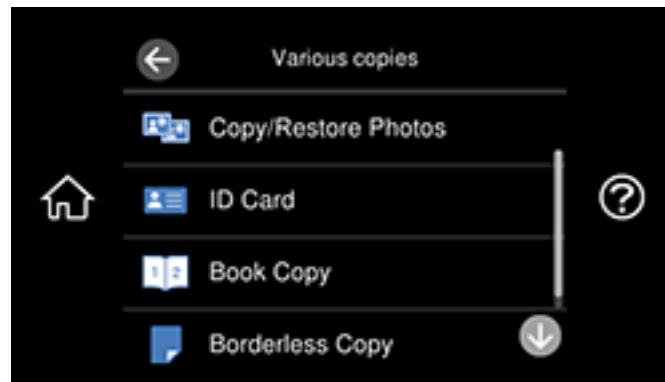

4. Select one of these options:
  - **ID Card**: Scan and copy both sides of an ID card onto one side of the paper.
  - **Book Copy**: Copy two facing pages of a book onto a single sheet of paper.

**Note:** Make sure the first page of your original is placed on the scanner glass as described on the LCD screen and select **Print Settings** to view and change the print settings, if necessary.

- **Borderless Copy:** Copy a photo with borders and remove the borders from the copy.
5. Place your book, card, or photo on the scanner glass.
  6. To print more than one copy, select **Copies** and use the displayed numeric keypad to select the number of copies (up to 99).
  7. Change any of the displayed settings as necessary.
  8. Select **Advanced Settings** to view and change additional copy settings, if necessary.
  9. Select **Preview** to preview your copy on the LCD screen.
  10. When you are ready to copy, select **Start Copy** or select the **Copy** icon.

**Note:** To cancel copying, select **Cancel**.

11. For **ID Card** and **Book Copy**, follow any on-screen instructions to place the rest of your originals and select **Start Scanning**.

**Parent topic:** [Copying](#)

**Related references**

[Compatible Epson Papers](#)

[Copying Options](#)

**Related topics**

[Loading Paper](#)

[Placing Originals on the Product](#)

## Copying Options

Select the copying options you want to use for your copies.

**Note:** Not all options or settings may be available, depending on other copying settings.

### Copy

Copying option	Available settings	Description
Color mode	<b>B&amp;W</b>	Select whether to copy the original in color or black and white
	<b>Color</b>	

Copying option	Available settings	Description
2-Sided	<b>1&gt;1-Sided</b>	Select to make 2-sided copies. When you select <b>1&gt;2-Sided</b> , scroll down and select the orientation and binding edge for your originals or copies.
	<b>1&gt;2-Sided</b>	
Density selector	Varying levels	Adjusts the lightness or darkness of copies

### Advanced Settings

Copying option	Available settings	Description
<b>Reduce/Enlarge</b>	<b>Actual Size</b>	Copies the original at its full size or 100% magnification
	<b>Auto Fit Page</b>	Automatically sizes the image to fit the paper size you selected
	<b>45%-&gt;195%</b> and other conversions	Automatically converts from one size to another
<b>Paper Setting</b>	Various options	View your paper source settings. Select the  icon to change the paper size and type for the selected source.
<b>Multi-Page</b>	<b>Single Page</b>	Copies each page of the original onto an individual sheet
	<b>2-up</b>	Copies two document pages onto one sheet. Scroll down and select the document orientation and other settings as necessary.
	<b>Off</b>	Copies one facing page of a book onto an individual sheet (available when <b>Book Copy</b> is selected)
<b>Quality</b>	<b>Draft</b>	Adjusts the quality of your copies
	<b>Standard</b>	
	<b>High</b>	
	<b>Best</b>	
<b>Remove Background</b>	<b>On</b>	Lightens the background of the original
	<b>Off</b>	
<b>Expansion</b>	Various settings	Enlarges the image to remove borders from the edges of the paper (available when <b>Borderless Copy</b> is selected)

Copying option	Available settings	Description
<b>Clear All Settings</b>	<b>Yes</b>	Restore all copy settings to their defaults
	<b>No</b>	

Parent topic: [Copying](#)

---

# Printing from a Computer

Before printing from your computer, make sure you have set up your product and installed its software as described on the *Start Here* sheet.

**Note:** If you have an Internet connection, it is a good idea to check for updates to your product software on Epson's support website. If you see a Software Update screen, select **Enable automatic checking** and click **OK**. The update scans your system to see if you have the latest product software. Follow the on-screen instructions.

[Printing with Windows](#)

[Printing with the Built-in Epson Driver - Windows 10 S](#)

[Printing on a Mac](#)

[Printing from a Smartphone or Tablet](#)

[Printing with Epson Photo+](#)

[Cancelling Printing From the LCD Screen](#)

## Printing with Windows

You can print with your product using any Windows application, as described in these sections.

**Note:** If you are using your Epson product with the Windows 10 S operating system, you cannot use the software described in this section. You also cannot download and install any Epson product software from the Epson website for use with Windows 10 S; you must obtain software only from the Windows Store.

[Selecting Basic Print Settings - Windows](#)

[Selecting Double-sided Printing Settings - Windows](#)

[Selecting Additional Layout and Print Options - Windows](#)

[Selecting a Printing Preset - Windows](#)

[Selecting Extended Settings - Windows](#)

[Printing Your Document or Photo - Windows](#)

[Checking Print Status - Windows](#)

[Selecting Default Print Settings - Windows](#)

[Changing Automatic Update Options](#)

**Parent topic:** [Printing from a Computer](#)

## Selecting Basic Print Settings - Windows

Select the basic settings for the document or photo you want to print.

1. Open a photo or document for printing.
2. Select the print command in your application.

**Note:** You may need to select a print icon on your screen, the **Print** option in the **File** menu, or another command. See your application's help utility for details.

3. If necessary, select your product name as the printer you want to use.

**Note:** You may also need to select **Properties** or **Preferences** to view your print settings.

You see the Main tab of your printer settings window:

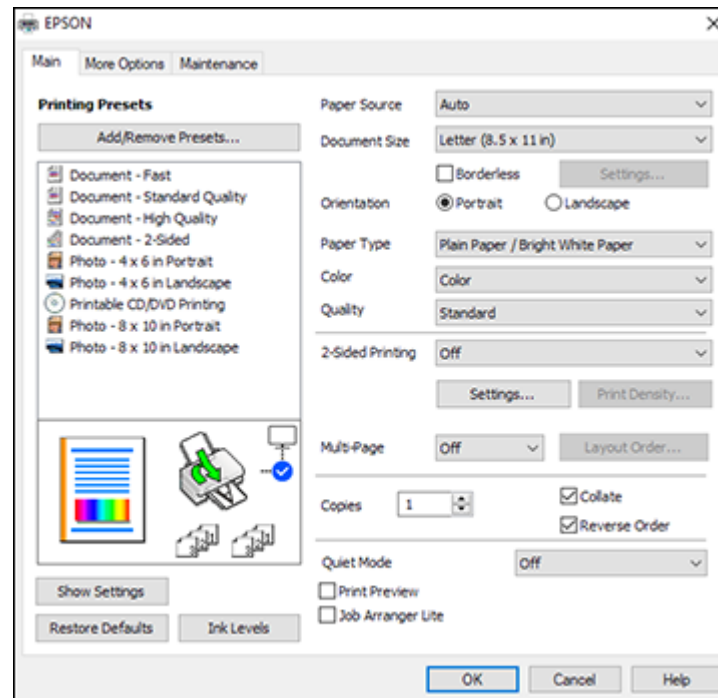

4. For the **Paper Source** setting, select where you loaded the paper you want to print on.

5. Select the size of the paper you loaded as the **Document Size** setting.

**Note:** You can also select the **User-Defined** setting to create a custom paper size.

6. If you are printing a borderless photo, select **Borderless**. You can click **Settings** to access additional options for borderless printing.

**Note:** You must select a compatible borderless paper type and size to print without borders. Check the borderless paper compatibility list for details.

7. Select the orientation of your document.

**Note:** If you are printing an envelope, select **Landscape**.

8. Select the type of paper you loaded as the **Paper Type** setting.

**Note:** The setting may not exactly match the name of your paper. Check the paper type settings list for details.

9. Select the **Quality** setting that matches the print quality you want to use.

10. Select a Color option:

- To print a color document or photo, select the **Color** setting.
- To print text and graphics in black or shades of gray, select the **Black/Grayscale** setting.

11. To print on both sides of the paper, select a **2-Sided Printing** option.

12. To print multiple pages on one sheet of paper, or print one image on multiple sheets of paper, select one of the settings in the **Multi-Page** menu and select the printing options you want.

13. To print multiple copies and arrange their print order, select the **Copies** options.

14. To reduce noise during printing, turn on **Quiet Mode** (printing will be slower).

15. To preview your job before printing, select **Print Preview**.

16. To save your print job as a project that can be modified and combined with other print jobs, select **Job Arranger Lite**.

[Paper Source Options - Windows](#)

[Print Quality Options - Windows](#)

[Multi-Page Printing Options - Windows](#)

**Parent topic:** [Printing with Windows](#)

**Related references**

[Borderless Paper Type Compatibility](#)

[Double-sided Printing Capacity](#)

[Paper or Media Type Settings - Printing Software](#)

**Related tasks**

[Printing Your Document or Photo - Windows](#)

**Paper Source Options - Windows**

You can select any of the available options in the Paper Source menu to print on the paper loaded in that source.

**Auto**

Automatically selects the paper source based on the selected paper size.

**Cassette 1**

Selects the paper in cassette 1 (upper) as the paper source.

**Cassette 2**

Selects the paper in cassette 2 (lower) as the paper source.

**Cassette 1 > Cassette 2**

Selects the paper in cassette 1 as the paper source and automatically switches to cassette 2 when cassette 1 is empty.

**Rear Paper Feeder**

Selects the paper in the rear paper feeder as the paper source.

**Rear Paper Feed Slot**

Selects the paper in the rear paper feed slot as the paper source.

**CD/DVD Tray**

Selects the CD or DVD loaded in the CD/DVD tray.

**Parent topic:** [Selecting Basic Print Settings - Windows](#)

**Related topics**

[Product Parts Locations](#)

**Print Quality Options - Windows**

You can select any of the available Quality options to fine-tune the quality of your print. Some settings may be unavailable, depending on the paper type and border setting you have chosen.



**Draft**

For draft printing on plain paper.

**Standard**

For everyday text and image printing.

**High**

For photos and graphics with high print quality.

**Best**

For the best print quality, but the slowest print speed.

**Parent topic:** [Selecting Basic Print Settings - Windows](#)

**Multi-Page Printing Options - Windows**

You can select any of the available options in the Multi-Page menu to set up your multi-page print job.

**2-Up, 4-Up, 6-Up, 8-Up, 9-Up, and 16-Up**

Prints several pages on one sheet of paper. Click the **Layout Order** button to select page layout and border options.

**2×1 Poster, 2×2 Poster, 3×3 Poster, 4×4 Poster**

Prints one image on multiple sheets of paper to create a larger poster. Click the **Settings** button to select image layout and guideline options.

**Parent topic:** [Selecting Basic Print Settings - Windows](#)

**Selecting Double-sided Printing Settings - Windows**

You can print on both sides of the paper by selecting one of the 2-Sided Printing options on the Main tab.

**Note:** Some options may be pre-selected or unavailable, depending on other settings you have chosen or if you are accessing the product over a network.

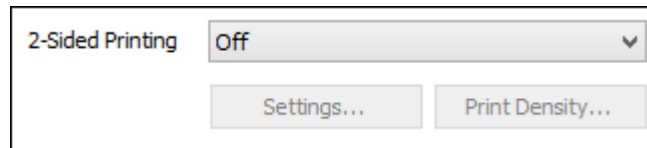

1. Select one of the following options for **2-Sided Printing**:
  - **Auto (Long-edge binding)** to print your double-sided print job by automatically flipping the paper on the long edge.

- **Auto (Short-edge binding)** to print your double-sided print job by automatically flipping the paper on the short edge.

2. Click the **Settings** button.

You see this window:

The screenshot shows a dialog box titled "Binding Settings" with the following sections:

- Binding Edge:** Three radio buttons are present: "Left Long-edge" (selected), "Top Short-edge", and "Right Long-edge". Each radio button is accompanied by a small icon representing the binding style.
- Binding Margin:** Two rows of controls. The first row is for the "Front Page" with a spinner box set to "0.00" and a range "[0.00 ... 1.18]". The second row is for the "Back Page" with a spinner box set to "0.00" and a range "[0.00 ... 1.18]".
- Unit:** Two radio buttons: "mm" and "inch" (selected).
- Start Page:** Two radio buttons: "From Front" (selected) and "From Back".
- Create Folded Booklet:** A checkbox labeled "Booklet" is unchecked. Below it are two radio buttons: "Center Binding" and "Side Binding".

At the bottom of the dialog box are three buttons: "OK", "Cancel", and "Help".

3. Select the double-sided printing options you want to use.
4. Click **OK** to return to the Main tab.
5. Click the **Print Density** button.

You see this window:

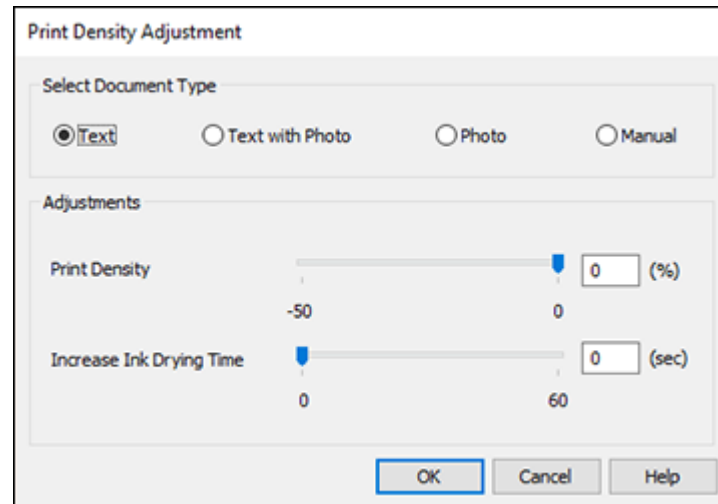

6. Select the type of document you are printing as the Document Type setting. The software automatically sets the Adjustments options for that document type.
7. If necessary, select the Adjustments options you want to use.
8. Click **OK** to return to the Main tab.
9. Print a test copy of your double-sided document to test the selected settings.
10. Follow any instructions displayed on the screen during printing.

[Double-sided Printing Options - Windows](#)

[Print Density Adjustments - Windows](#)

**Parent topic:** [Printing with Windows](#)

**Related references**

[Double-sided Printing Capacity](#)

## **Related tasks**

[Selecting Basic Print Settings - Windows](#)

### **Double-sided Printing Options - Windows**

You can select any of the available options on the Binding Settings window to set up your double-sided print job.

#### **Binding Edge Options**

Select a setting that orients double-sided print binding in the desired direction.

#### **Binding Margin Options**

Select options that define a wider margin to allow for binding.

#### **Start Page**

Selects whether printing starts on the front or back page.

#### **Create Folded Booklet Options**

Select the **Booklet** checkbox and a binding option to print double-sided pages as a booklet.

**Parent topic:** [Selecting Double-sided Printing Settings - Windows](#)

### **Print Density Adjustments - Windows**

You can select any of the available options on the Print Density Adjustment window to adjust the print quality of your double-sided print job.

#### **Print Density**

Sets the level of ink coverage for double-sided printing.

#### **Increase Ink Drying Time**

Sets the amount of time required for drying ink after printing on one side of the paper before printing the other side in double-sided printing to prevent ink smearing.

**Parent topic:** [Selecting Double-sided Printing Settings - Windows](#)

## Selecting Additional Layout and Print Options - Windows

You can select a variety of additional layout and printing options for your document or photo on the **More Options** tab.

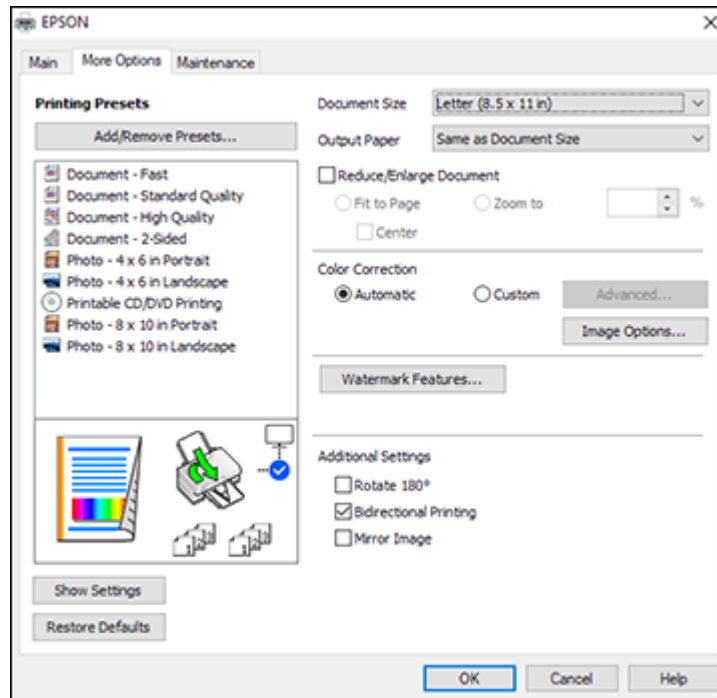

1. To change the size of your printed document or photo, select the **Reduce/Enlarge Document** checkbox and select one of these sizing options:
  - Select the **Fit to Page** option to size your image to fit the paper you loaded. Select the size of your document or photo as the Document Size setting, and the size of your paper as the Output Paper setting. If you want to center your image on the paper, select the **Center** option.
  - Select the **Zoom to** option to reduce or enlarge your document or photo by a specific percentage. Select the percentage in the % menu.
2. Select one of the following Color Correction options:
  - Select **Automatic** to automatically adjust the sharpness, brightness, contrast, and color saturation for your image.

- Select **Custom** and click the **Advanced** button to manually adjust the color correction settings or turn off color management in your printer software.
- Select **Image Options** to access additional settings for improving printed images.

**Note:** You can also select **Color Universal Print** settings.

3. To add the following features, click the **Watermark Features** button:

- **Anti-Copy Pattern:** adds a watermark that only appears when your printout is copied

**Note:** This setting is not available for all types of printing. Click the **Add/Delete** button to create your own pattern, and click the **Settings** button to customize the pattern.

- **Watermark:** adds a visible watermark to your printout

**Note:** Click the **Add/Delete** button to create your own watermark, and click the **Settings** button to customize the watermark.

- **Header/Footer:** adds information such as the date and time to the top or bottom of your printout

**Note:** Click the **Settings** button to customize the text and location of the header or footer.

4. Select any of the Additional Settings options to customize your print.

[Custom Color Correction Options - Windows](#)

[Image Options and Additional Settings - Windows](#)

[Header/Footer Settings - Windows](#)

**Parent topic:** [Printing with Windows](#)

**Related tasks**

[Printing Your Document or Photo - Windows](#)

## Custom Color Correction Options - Windows

You can select any of the available options in the Color Correction window to customize the image colors for your print job.

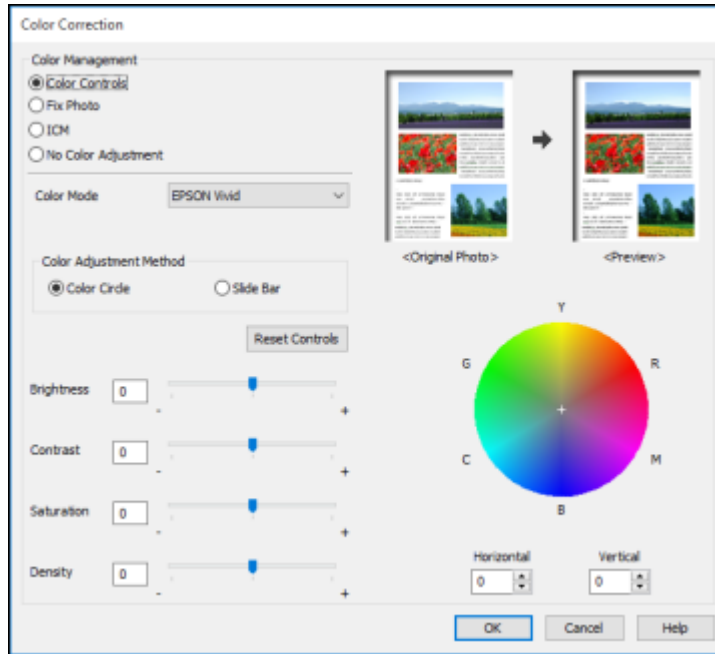

### Color Controls

Lets you select a **Color Mode** setting, individual settings for **Brightness**, **Contrast**, **Saturation**, and **Density**, and individual color tones. Depending on the selected color mode, you can also adjust the midtone density using the **Gamma** setting.

### Fix Photo

Improves the color, contrast, and sharpness of flawed photos.

**Note:** Fix Photo uses a sophisticated face recognition technology to optimize photos that include faces. For this to work, both eyes and the nose must be visible in the subject's face. If your photo includes a face with an intentional color cast, such as a statue, you may want to turn off **Fix Photo** to retain the special color effects.

**ICM**

Lets you manage color using installed color printing profiles.

**No Color Adjustment**

Turns off color management in your printer software so you can manage color using only your application software.

**Parent topic:** [Selecting Additional Layout and Print Options - Windows](#)

**Image Options and Additional Settings - Windows**

You can select any of the Image Options and Additional Settings to customize your print. Some options may be pre-selected or unavailable, depending on other settings you have chosen.

**Image Options****Emphasize Text**

Adjusts the weight of printed text to increase readability.

**Emphasize Thin Lines**

Adjusts the weight of printed lines to increase visibility.

**Edge Smoothing**

Smooths jagged edges in low-resolution images such as screen captures or images from the Web.

**Fix Red-Eye**

Reduces or removes red-eye in photos.

**Print Text in Black**

Prints colored text in black.

**For Color Text**

Prints colored text on a background pattern or underlined.

**For Color Graphs and Images**

Prints colored graphics and images with overlay patterns.

**For Color Text, Graphs, and Images**

Prints colored text, graphics, and images with overlay patterns.

**Additional Settings Options****Rotate 180°**

Prints the image rotated 180° from its original orientation.

**Bidirectional Printing**

Prints in both directions (right-to-left and left-to-right), speeding up printing, but may reduce print quality.



### Mirror Image

Flips the printed image left to right.

**Parent topic:** [Selecting Additional Layout and Print Options - Windows](#)

### Header/Footer Settings - Windows

You can select any of the Header/Footer Settings options to add headers or footers when you print. The items are available to print at the top or bottom of your pages, in either the left, right, or center of the page.

**Note:** These settings are not saved with your document.

The screenshot shows the 'Header/Footer Settings' dialog box. It is organized into several sections:

- Header/Footer Selection:** A grid of six dropdown menus for selecting content to print in different positions:
  - Top Left: User Name
  - Top Center: None
  - Top Right: Date/Time
  - Bottom Left: None
  - Bottom Center: None
  - Bottom Right: None
- Page Settings:** Two spinners for 'Starting number' and 'Start printing on page', both set to 1.
- Text:** An empty text input field.
- Appearance:** Settings for the header/footer text:
  - Color: Black
  - Font: Arial
  - Size: 11 pt [6 ... 72]
  - Style: A checkbox area with 'Bold' and 'Italic' options.
- Buttons:** 'Reset Defaults', 'OK', 'Cancel', and 'Help' buttons at the bottom.

You can select to print the following information:

- User Name
- Computer Name
- Date
- Date/Time
- Document Name
- Collate Number
- Page Number
- Text

You can also adjust the text settings for the printed information.

**Note:** The user name, computer name, date, and time come from the Windows Control Panel on your computer.

**Parent topic:** [Selecting Additional Layout and Print Options - Windows](#)

## Selecting a Printing Preset - Windows

For quick access to common groups of print settings, you can select a printing preset on the **Main** or **More Options** tab.

**Note:** You can create your own preset by clicking the **Add/Remove Presets** button.

1. Click the **Main** or **More Options** tab.

You see the available **Printing Presets** on the left:

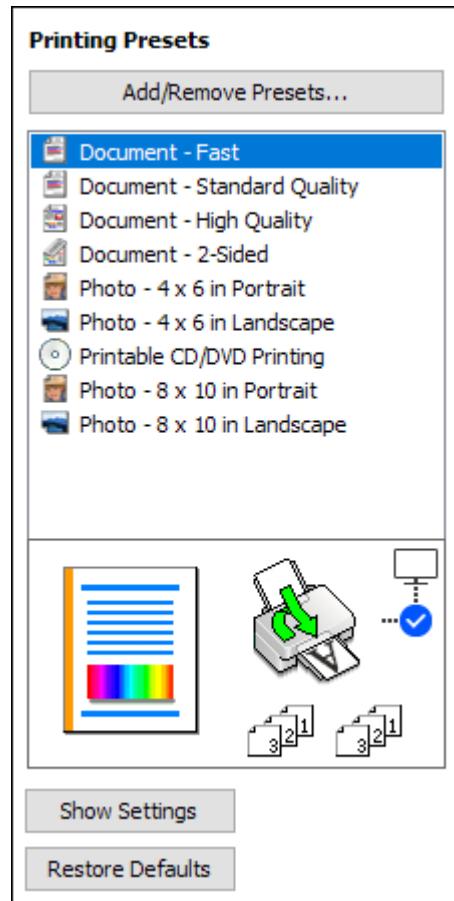



2. Place your cursor over one of the **Printing Presets** to view its list of settings.
3. Click on a preset to change its settings or delete it, or use any of the available options on the screen to control your printing presets.
4. To choose a preset for printing, select it.
5. Click **OK**.

**Parent topic:** [Printing with Windows](#)

## Selecting Extended Settings - Windows

You can select additional settings that apply to all the print jobs you send to your product.

1. Access the Windows Desktop and right-click the  icon for your product in the right side of the Windows taskbar, or click the up arrow and right-click .
2. Select **Printer Settings**.
3. Click the **Maintenance** tab.

You see the maintenance options:

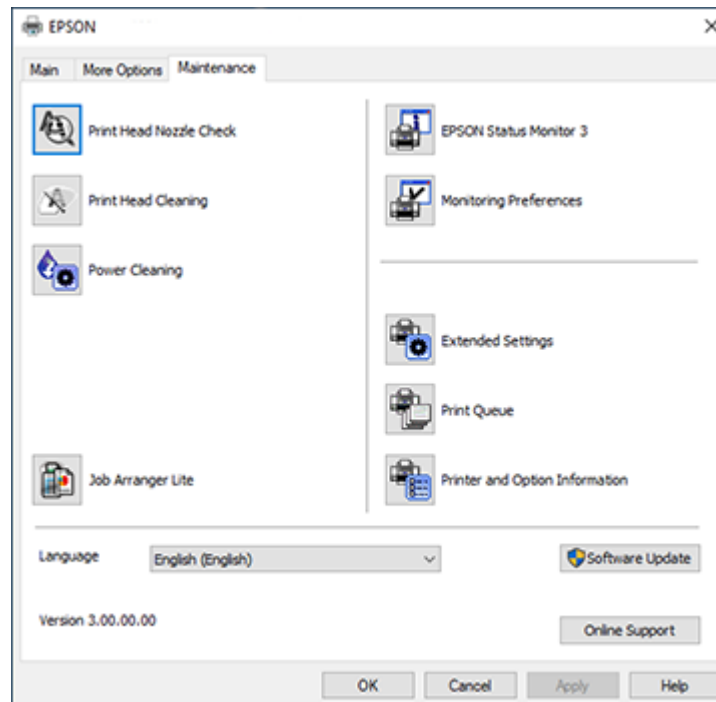

4. Click the **Extended Settings** button.

You see this window:

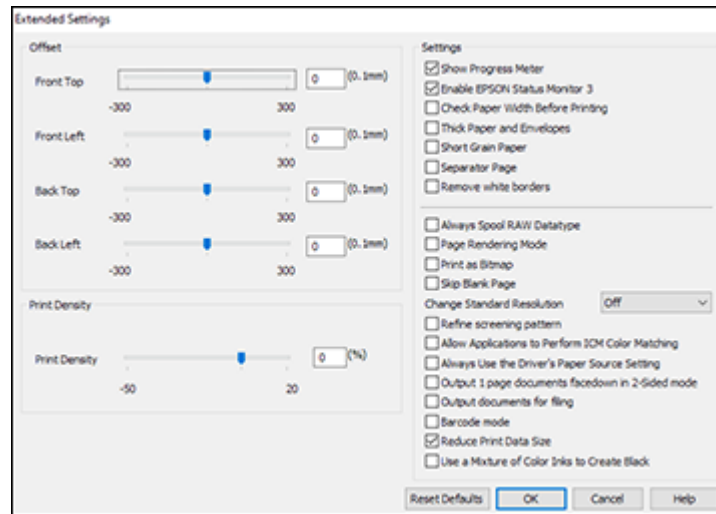

5. Select any of the extended settings to customize your print.
6. Click **OK** to close the Extended Settings window.
7. Click **OK** to close the printer software window.

[Extended Settings - Windows](#)

**Parent topic:** [Printing with Windows](#)

### **Extended Settings - Windows**

You can select these settings on the Extended Settings window.

#### **Show Progress Meter**

Displays the progress of print jobs as they are being printed.

#### **Enable EPSON Status Monitor 3**

Enables product monitoring for ink and paper supplies and other issues.

#### **Check Paper Width Before Printing**

Prevents printing beyond the edges of the paper if the paper size setting is incorrect; may reduce print speed.

#### **Thick Paper and Envelopes**

Prevents ink from smearing when you print on envelopes or other thick paper.

**Short Grain Paper**

Prevents ink from smearing when you print on envelopes or other thick paper, and the **Thick Paper** setting does not help.

**Separator Page**

Before each document, prints a separator page containing the title, user, date, and time.

**Remove white borders**

Removes white margins that may appear when you print borderless photos.

**Always Spool RAW Datatype**

Increases print speed and may solve other printing problems.

**Page Rendering Mode**

Increases print speed when printing is extremely slow or the print head stops during printing.

**Print as Bitmap**

Increases print speed when printing is extremely slow or the print head stops during printing, and other settings do not help.

**Skip Blank Page**

Ensures that your product does not print pages that contain no text or images.

**Change Standard Resolution**

Reduces the resolution of print data to correct printing problems.

**Refine screening pattern**

Prints graphics with a finer screening pattern.

**Allow Applications to Perform ICM Color Matching**

Allows applications to perform ICM color matching.

**Always Use the Driver's Paper Source Setting**

Prints using the paper source setting in the printer driver, rather than the setting in your application.

**Output 1 page documents facedown in 2-Sided mode**

Outputs single-sided pages in a 2-sided print job facedown instead of faceup.

**Output documents for filing**

Outputs all landscape, portrait, 1-sided, and 2-sided documents in the same orientation for easier filing.

**Barcode mode**

Reduces bleeding when printing barcodes on plain paper, letterhead paper, recycled paper, preprinted paper, envelopes, and thick paper.

### Reduce Print Data Size

Increases print data compression to improve print speed. Not recommended when printing fine patterns.

### Use a Mixture of Color Inks to Create Black

Mixes color inks to create composite black when printing at standard quality on plain paper or envelopes.

Parent topic: [Selecting Extended Settings - Windows](#)

## Printing Your Document or Photo - Windows

Once you have selected your print settings, you are ready to save your settings and print.

1. Click **OK** to save your settings.

You see your application's Print window, such as this one:

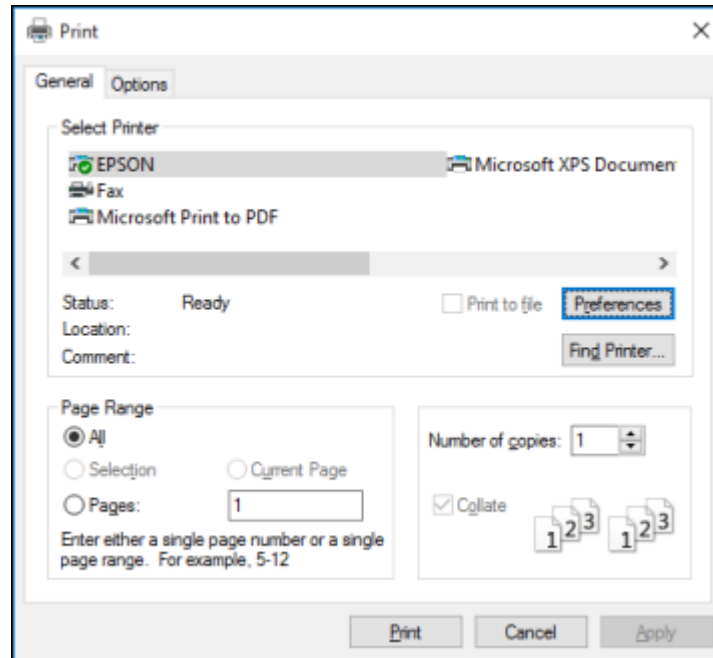

2. Click **OK** or **Print** to start printing.

Parent topic: [Printing with Windows](#)

## Related tasks

[Selecting Basic Print Settings - Windows](#)

## Checking Print Status - Windows

During printing, you see this window showing the progress of your print job. It allows you to control printing and check ink status.

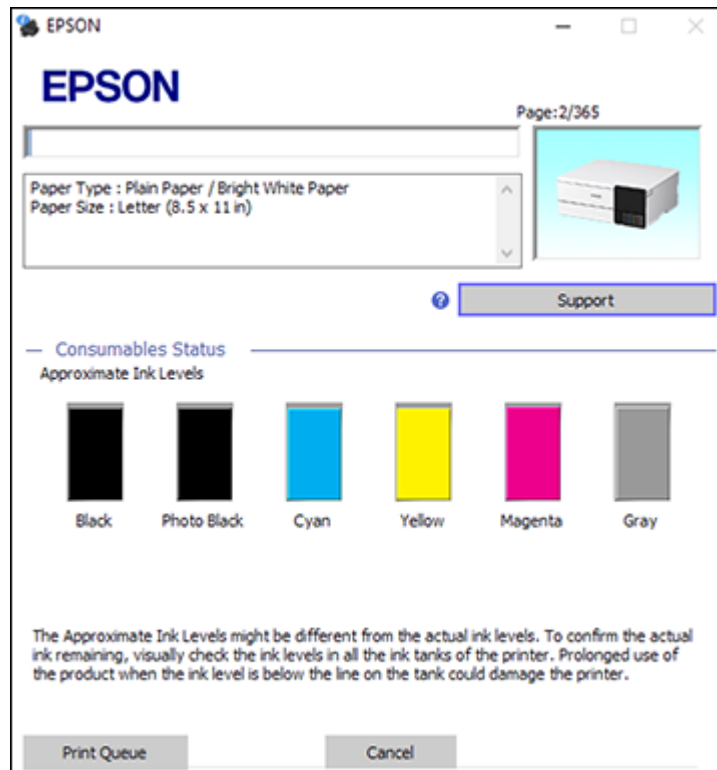



- To cancel printing, click **Cancel**.
- To see print jobs lined up for printing, click **Print Queue**.

**Parent topic:** [Printing with Windows](#)



## Selecting Default Print Settings - Windows

When you change your print settings in a program, the changes apply only while you are printing in that program session. If you want to change the print settings you use in all your Windows programs, you can select new default print settings.

1. Access the Windows Desktop and right-click the  icon for your product in the right side of the Windows taskbar, or click the up arrow and right-click .
2. Select **Printer Settings**.

You see the printer settings window:

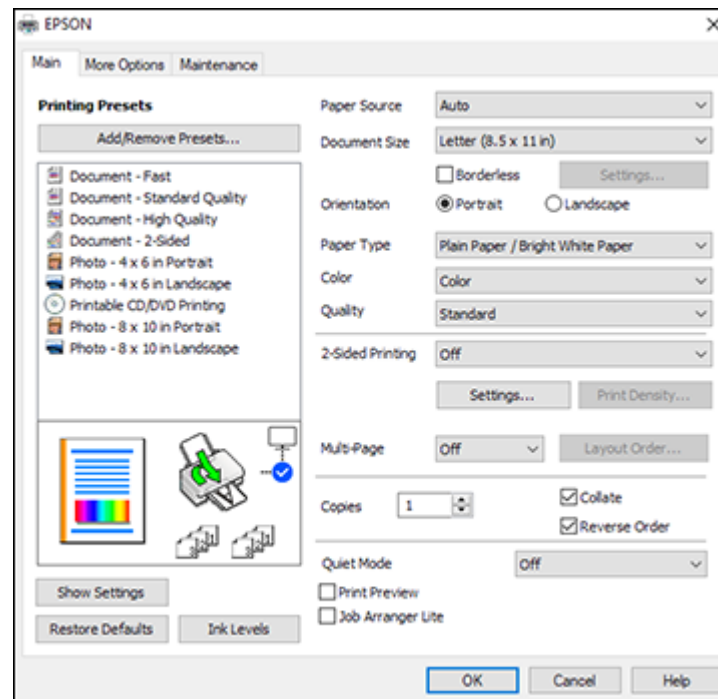

3. Select the print settings you want to use as defaults in all your Windows programs.
4. Click **OK**.



These settings are now the defaults selected for printing. You can still change them as needed for printing in any program session.

## Changing the Language of the Printer Software Screens

**Parent topic:** [Printing with Windows](#)

### Changing the Language of the Printer Software Screens

You can change the language used on the Windows printer software screens.

1. Access the Windows Desktop and right-click the  icon for your product in the right side of the Windows taskbar, or click the up arrow and right-click .

2. Select **Printer Settings**.

You see the printer settings window.

3. Click the **Maintenance** tab.

You see the maintenance options:

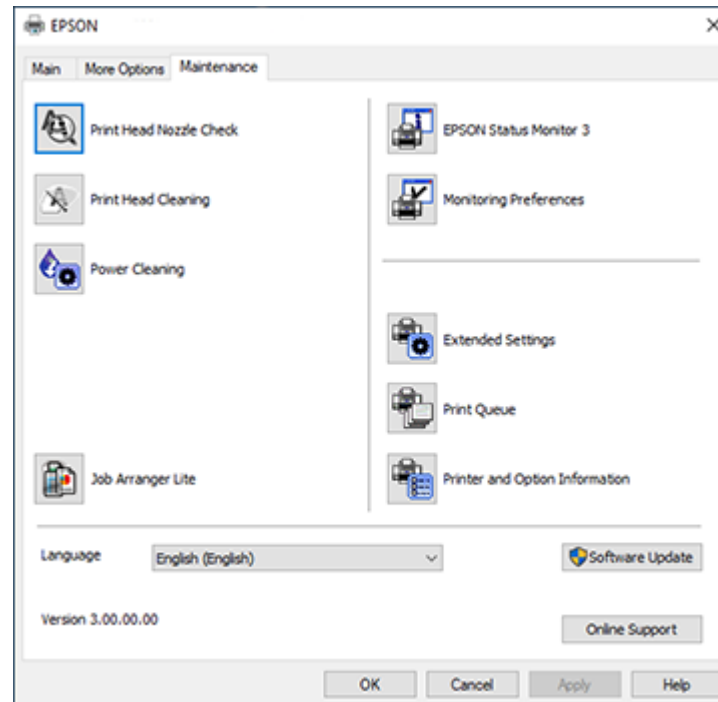

4. Select the language you want to use as the **Language** setting.



5. Click **OK** to close the printer software window.

The printer software screens appear in the language you selected the next time you access them.

**Parent topic:** [Selecting Default Print Settings - Windows](#)

## Changing Automatic Update Options

Your printer software for Windows automatically checks for updates to the product software. You can change how often the software checks for updates or disable this feature.

1. Access the Windows Desktop and right-click the  icon for your product in the right side of the Windows taskbar, or click the up arrow and right-click .
2. Select **Software Update Settings**.

You see this window:

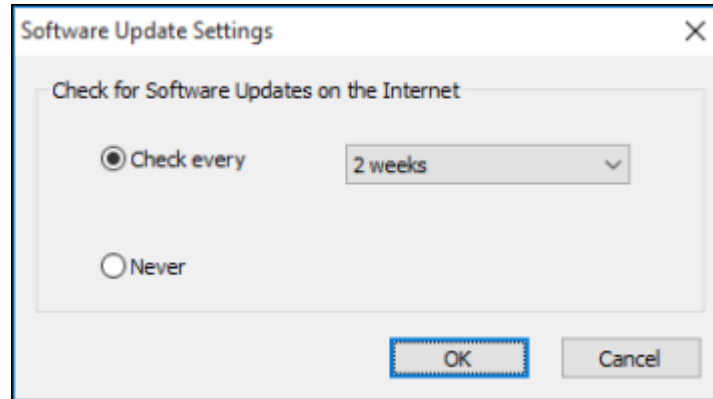

3. Do one of the following:
  - To change how often the software checks for updates, select a setting in the **Check every** menu.
  - To disable the automatic update feature, select the **Never** option.
4. Click **OK** to exit.

**Note:** If you choose to disable the automatic update feature, you can check for updates manually.

**Parent topic:** [Printing with Windows](#)

## Related tasks

[Checking for Software Updates](#)

# Printing with the Built-in Epson Driver - Windows 10 S

You can print with the built-in Epson printer driver using any printing program on Windows 10 S, as described in these sections.

**Note:** The built-in Epson driver in Windows 10 S does not include all the available print settings for your product. To print with additional settings, download and install the Epson Print and Scan utility from the Windows Store. You cannot download and install any Epson product software from the Epson website for use with Windows 10 S; you must obtain software only from the Windows Store.

[Selecting Print Settings - Windows 10 S](#)

**Parent topic:** [Printing from a Computer](#)

## Selecting Print Settings - Windows 10 S

Select the settings for your print job in your Windows 10 S application.

1. Open a photo or document for printing.
2. Select the print command in your application.

**Note:** You may need to select a print icon on your screen, the **Print** option in the **File** menu, or another command. See your application's help utility for details.

3. If necessary, select your product name as the printer you want to use.

**Note:** You may also need to select **Properties** or **Preferences** to view your print settings.

You see a window like this:

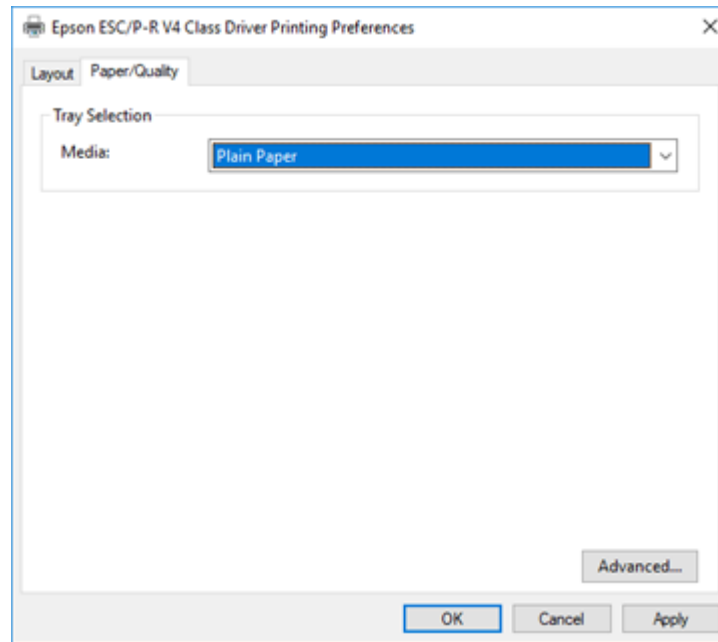

4. Select the type of paper you loaded as the **Media** setting.

**Note:** The setting may not exactly match the name of your paper. Check the paper type settings list for details.

5. Click the **Advanced** button.

You see a window like this:

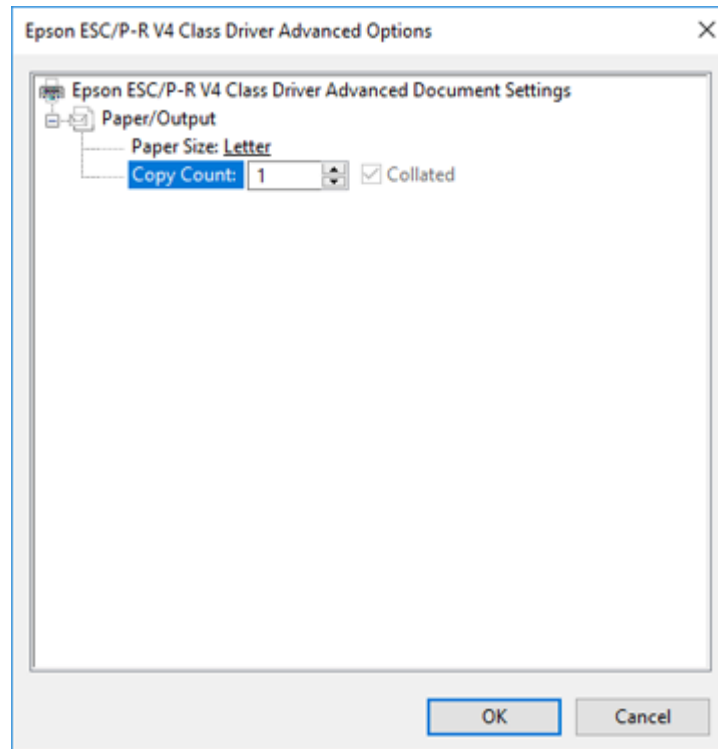

6. Select the size of the paper you loaded as the **Paper Size** setting.
7. To print multiple copies, select or enter the number as the **Copy Count** setting.
8. To print multiple copies of multi-page documents in sets, select the **Collated** checkbox.
9. Click **OK**.

You return to the printing preferences window.

10. Select the **Layout** tab.

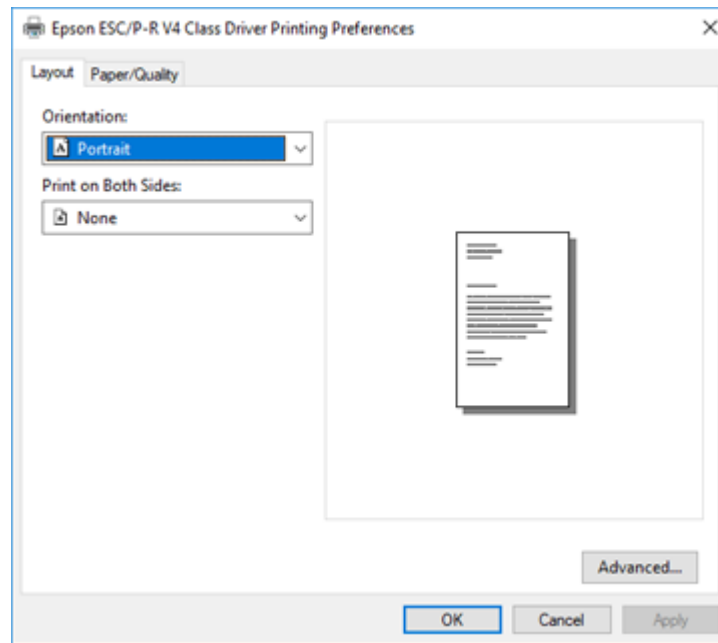

11. Select the orientation of your document as the **Orientation** setting.

- To print double-sided, select one of the **Print on Both Sides** options, depending on how you want to orient the page layout. The icon next to each option shows the layout.

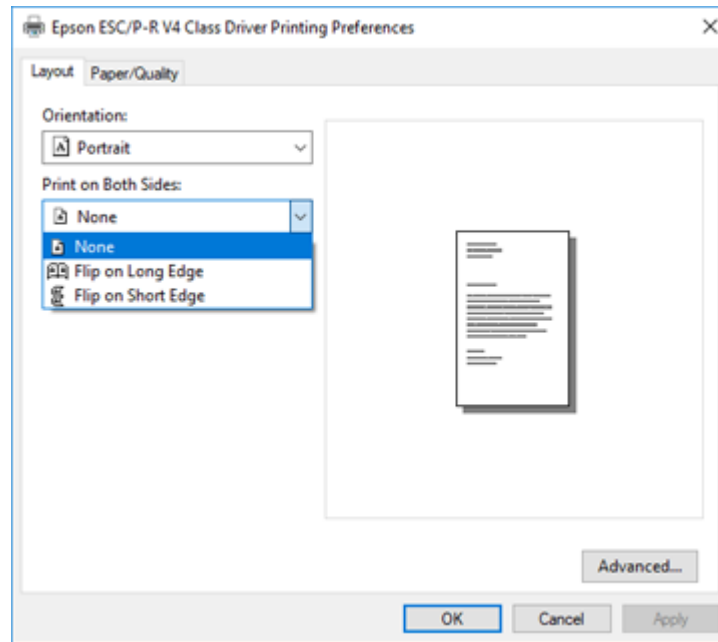

- Click **OK** to save your settings.

You see your application's **Print** window.

- Click **OK** or **Print** to start printing.

**Parent topic:** [Printing with the Built-in Epson Driver - Windows 10 S](#)

## Printing on a Mac

You can print with your product using any Mac printing program, as described in these sections.

**Note:** If you have an Internet connection, it is a good idea to check for updates to your product software on Epson's support website.

[Selecting Basic Print Settings - Mac](#)

[Selecting Page Setup Settings - Mac](#)



- [Selecting Print Layout Options - Mac](#)
  - [Selecting Double-sided Printing Settings - Mac](#)
  - [Managing Color - Mac](#)
  - [Selecting Printing Preferences - Mac](#)
  - [Printing Your Document or Photo - Mac](#)
- Parent topic:** [Printing from a Computer](#)

## Selecting Basic Print Settings - Mac

Select the basic settings for the document or photo you want to print.

1. Open a photo or document for printing.
2. Select the print command in your application.

**Note:** You may need to select a print icon on your screen, the **Print** option in the File menu, or another command. See your application's help utility for details.

3. Select your product as the **Printer** setting.

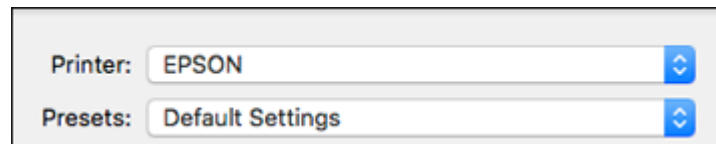

4. If necessary, click the arrow next to the Printer setting or the **Show Details** button to expand the print window.

You see the expanded printer settings window for your product:

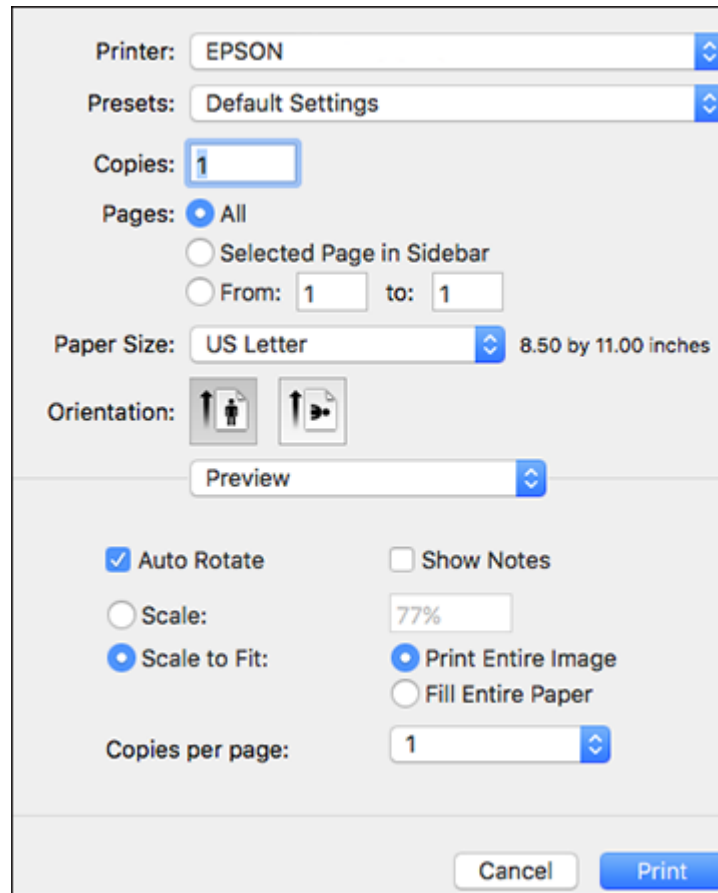

**Note:** The print window may look different, depending on the Mac OS version and the application you are using.

5. Select the **Copies** and **Pages** settings as necessary.

**Note:** If you do not see these settings in the print window, check for them in your application before printing.

6. Select the page setup options: **Paper Size** and **Orientation**.

**Note:** If you do not see these settings in the print window, check for them in your application before printing. They may be accessible by selecting **Page Setup** from the File menu.

**Note:** Paper sizes may include additional options such as **Borderless** or **Rear Paper Feed Slot**.

7. Select any application-specific settings that appear on the screen, such as those shown in the image above for the Preview application.
8. Select **Print Settings** or **Printer Features** from the pop-up menu.

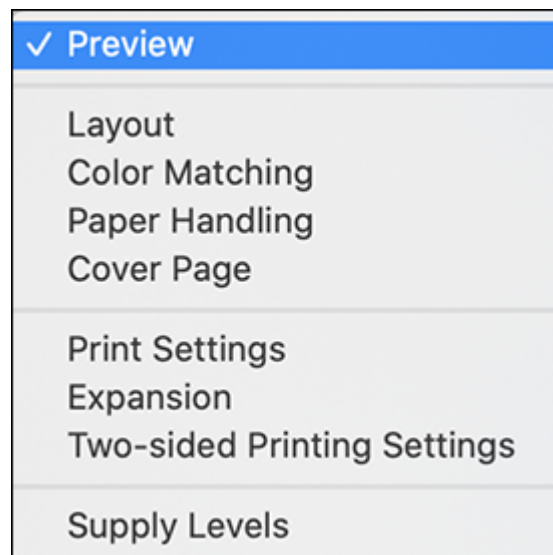

You see these settings:

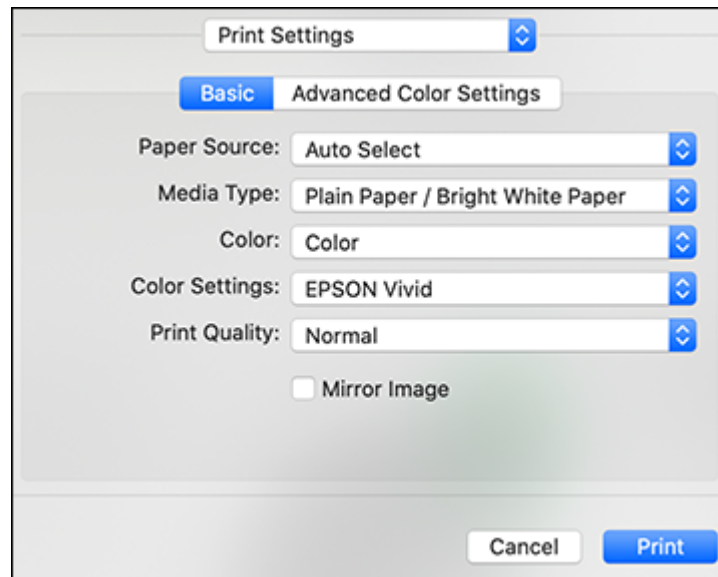

**Note:** The available print settings and appearance of the print window may be different than those covered here, depending on the Mac OS version and the application you are using.

9. Select the **Paper Source** you wish to print from.
10. Select the type of paper you loaded as the **Media Type** setting.

**Note:** The setting may not exactly match the name of your paper. Check the paper type settings list for details.

11. Select the **Print Quality** setting you want to use.
12. Select any of the available print options.

[Paper Source Options - Mac](#)

[Print Quality Settings - Mac](#)

**Parent topic:** [Printing on a Mac](#)

## Related tasks

[Selecting Page Setup Settings - Mac](#)

### Paper Source Options - Mac

You can select any of the available options in the Paper Source menu to print on the paper loaded in that source.

#### Auto Select

Automatically selects the paper source based on the selected paper size.

#### Cassette 1

Selects the paper in cassette 1 (upper) as the paper source.

#### Cassette 2

Selects the paper in cassette 2 (lower) as the paper source.

#### Rear Paper Feed

Selects the paper in the rear paper feeder as the paper source.

**Note:** To select the rear paper feed slot as the paper source, select the option for the compatible paper size in the **Paper Size** setting.

**Parent topic:** [Selecting Basic Print Settings - Mac](#)

## Related topics

[Product Parts Locations](#)

### Print Quality Settings - Mac

You can select any of the **Print Quality** settings to fine-tune the quality of your print. Some settings may be unavailable, depending on the paper type and border setting you have chosen.

#### Economy

For fast printing with reduced quality.

#### Normal

For everyday text and image printing.

#### Fine

For text and graphics with good quality and print speed.

#### Best Quality

For the best print quality, but the slowest print speed.

**Parent topic:** [Selecting Basic Print Settings - Mac](#)

## Selecting Page Setup Settings - Mac

Depending on your application, you may be able to select the paper size and orientation settings from the print window.

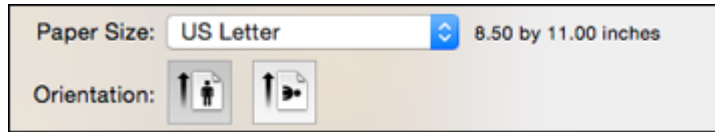

**Note:** If you do not see these settings in the print window, check for them in your application before printing. They may be accessible by selecting **Page Setup** from the File menu.

1. Select the size of the paper you loaded as the **Paper Size** setting. If you are printing a borderless photo, select the **Borderless** checkbox or a paper size with a **Borderless** option. You can also select a custom setting to create a custom paper size.

**Note:** You must select a compatible borderless paper type and size to print without borders. Check the borderless paper compatibility list for details.

2. Select the orientation of your document or photo as shown in the print window.

**Note:** If you are printing an envelope, select the  icon.

**Note:** You can reduce or enlarge the size of the printed image by selecting **Paper Handling** from the pop-up menu and selecting a scaling option.

**Parent topic:** [Printing on a Mac](#)

## Selecting Print Layout Options - Mac

You can select a variety of layout options for your document or photo by selecting **Layout** from the pop-up menu on the print window.

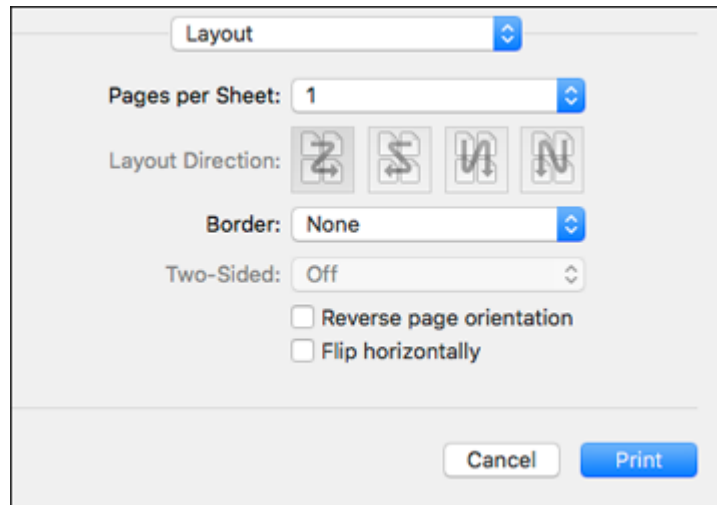

- To print multiple pages on one sheet of paper, select the number of pages in the **Pages per Sheet** pop-up menu. To arrange the print order of the pages, select a **Layout Direction** setting.
- To print borders around each page on the sheet, select a line setting from the **Border** pop-up menu.
- To print on both sides of each page, select a setting from the **Two-Sided** pop-up menu.
- To invert or flip the printed image, select the **Reverse page orientation** or **Flip horizontally** settings.

**Parent topic:** [Printing on a Mac](#)

## Selecting Double-sided Printing Settings - Mac

You can print on both sides of the paper by selecting **Two-sided Printing Settings** from the pop-up menu on the print window.

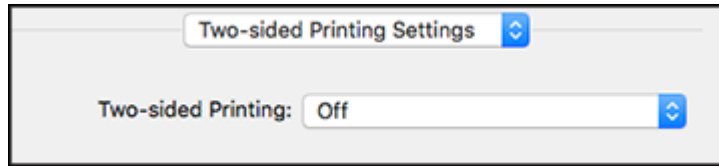

**Note:** Some options may be pre-selected or unavailable, depending on other settings you have chosen or if you are accessing the product over a network. This screen may be different, depending on the Mac OS version you are using.

1. Select one of the **Two-sided Printing** options.
2. Select the type of document you are printing as the **Document Type** setting. The software automatically sets the Adjustments options for that document type.

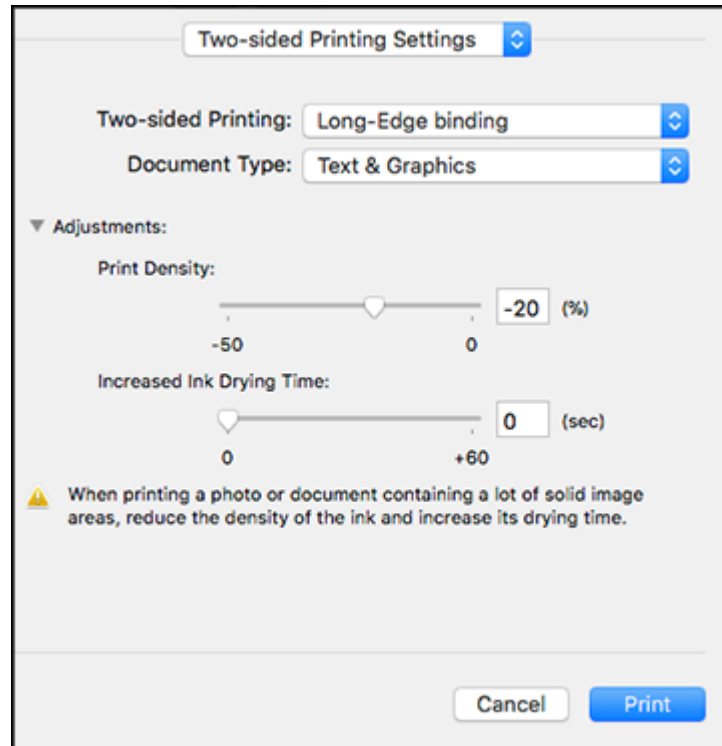

3. If necessary, customize the Adjustments settings as instructed on the screen.



4. Print a test copy of your double-sided document to test the selected settings.
5. Follow any instructions displayed on the screen during printing.

[Double-sided Printing Options and Adjustments - Mac](#)

**Parent topic:** [Printing on a Mac](#)

#### **Related references**

[Double-sided Printing Capacity](#)

### **Double-sided Printing Options and Adjustments - Mac**

You can select any of the available options in the **Two-sided Printing Settings** or **Output Settings** pop-up menu to set up your double-sided print job.

#### **Two-sided Printing Options**

##### **Long-Edge binding**

Orients double-sided printed pages to be bound on the long edge of the paper.

##### **Short-Edge binding**

Orients double-sided printed pages to be bound on the short edge of the paper.

#### **Adjustments**

##### **Print Density**

Sets the level of ink coverage for double-sided printing.

##### **Increased Ink Drying Time**

Sets the amount of time required for drying ink after printing on one side of the paper before printing the other side in double-sided printing.

**Parent topic:** [Selecting Double-sided Printing Settings - Mac](#)

### **Managing Color - Mac**

You can adjust the Color Matching settings to fine-tune the colors in your printout, or turn off color management in your printer software.

1. Select **Color Matching** from the pop-up menu in the print window.

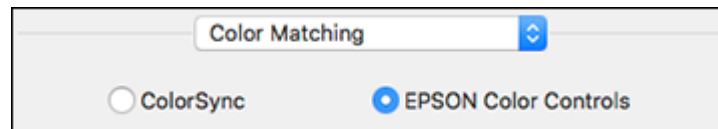

2. Select one of the available options.

[Color Matching and Color Options - Mac](#)

**Parent topic:** [Printing on a Mac](#)

## **Color Matching and Color Options - Mac**

You can select these settings on the **Color Matching** and **Color Options** menus.

### **Color Matching Settings**

#### **EPSON Color Controls**

Lets you manage color using controls in your printer driver or turn off color management.

#### **ColorSync**

Prints using standard color profiles for your product and paper to help match image colors. You can customize the conversion method and filter settings on the ColorSync pop-up menu in the print window.

### **Color Options Settings**

**Note:** These options may be located under Print Settings in the dropdown menu.

#### **EPSON Vivid**

Processes colors to create standard hues. Click the **Advanced Color Settings** tab to use advanced color controls.

#### **EPSON Standard (sRGB)**

Increases the contrast in images. Click the **Advanced Color Settings** tab to use advanced color controls.

#### **Adobe RGB**

Matches image colors to the Adobe RGB color standard. Use this setting if your source file was captured in Adobe RGB. Click the **Advanced Color Settings** tab to use advanced color controls.

#### **Fix Photo**

Improves the color, contrast, and sharpness of flawed photos. Click the arrow next to **Advanced Settings** and select the **Fix Red-Eye** setting to reduce or remove red-eye in photos.

**Note:** Fix Photo uses a sophisticated face recognition technology to optimize photos that include faces. For this to work, both eyes and the nose must be visible in the subject's face. If your photo includes a face with an intentional color cast, such as a statue, you may want to turn off **Fix Photo** to retain the special color effects.

### Off (No Color Adjustment)

Turns off color management in your printer software so you can manage color using only your application software.

**Note:** An ICC profile is required if color management is turned off.

Parent topic: [Managing Color - Mac](#)

## Selecting Printing Preferences - Mac

You can select printing preferences that apply to all the print jobs you send to your product.

1. In the Apple menu or the Dock, select **System Preferences**.
2. Select **Print & Fax**, **Print & Scan**, or **Printers & Scanners**, select your product, and select **Options & Supplies**.
3. Select **Driver** or **Options**.

You see a screen like this:

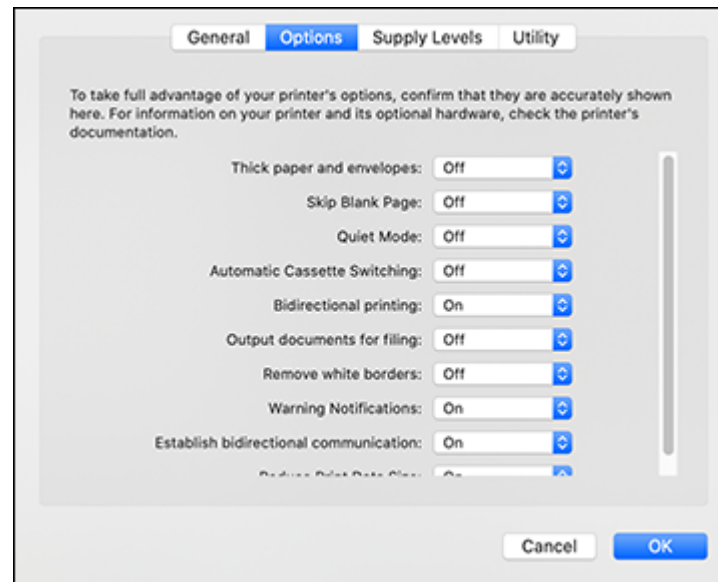

4. Select any of the available printing preferences.

5. Click **OK**.

[Printing Preferences - Mac](#)

**Parent topic:** [Printing on a Mac](#)

## **Printing Preferences - Mac**

You can select these settings on the **Options** or **Driver** tab.

### **Thick Paper and Envelopes**

Prevents ink from smearing when you print on envelopes or other thick paper.

### **Skip Blank Page**

Ensures that your product does not print pages that contain no text or images.

### **Quiet Mode**

Lessens noise during printing but may decrease print speed.

### **Automatic Cassette Switching**

Automatically switches to the other cassette when one of the cassettes runs out of paper.

### **Bidirectional printing**

Prints in both directions (right-to-left and left-to-right), speeding up printing, but may reduce print quality.

### **Output documents for filing**

Outputs all landscape, portrait, 1-sided, and 2-sided documents in the same orientation for easier filing.

### **Remove white borders**

Removes white margins that may appear when you print borderless photos.

### **Warning Notifications**

Lets you choose whether or not to receive warning notifications from the printer software for various operating conditions.

### **Establish bidirectional communication**

Allows the product to communicate with the computer. Do not change the default setting unless you experience issues when using a shared printing pool.

### **Reduce Print Data Size**

Increases print data compression to improve print speed. Not recommended when printing fine patterns.

**Parent topic:** [Selecting Printing Preferences - Mac](#)

## Printing Your Document or Photo - Mac

Once you have selected your print settings, you are ready to print.  
Click **Print** at the bottom of the print window.

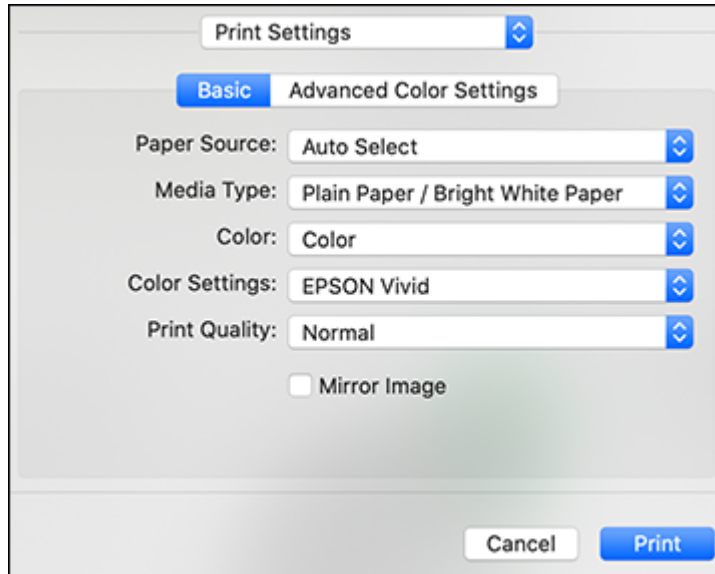

[Checking Print Status - Mac](#)

**Parent topic:** [Printing on a Mac](#)

**Related tasks**

[Selecting Basic Print Settings - Mac](#)

### Checking Print Status - Mac



During printing, you can view the progress of your print job, control printing, and check ink status.

1. Click the printer icon when it appears in the Dock.

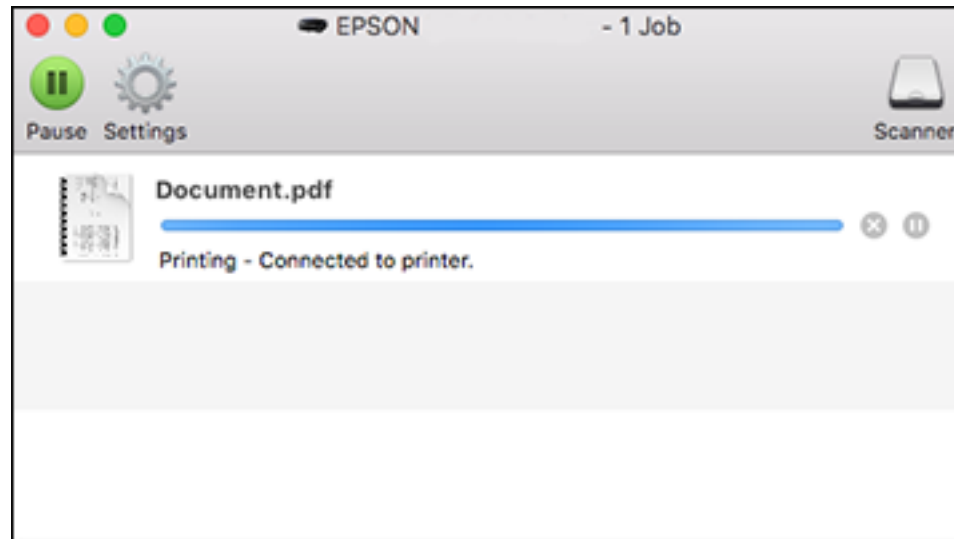
You see the print status window:



2. Select the following options as necessary for your Mac OS version:

- To cancel printing, click the print job and click  or **Delete**.
- To pause a print job, click the print job and click  or **Hold**. To resume a print job, click the paused print job and click  or **Resume**.
- To pause printing for all queued print jobs, click **Pause** or **Pause Printer**.
- To display other printer information, click **Settings** or **Supply Levels**.

Parent topic: [Printing Your Document or Photo - Mac](#)

## Printing from a Smartphone or Tablet

You can print from a smartphone or tablet running iOS or Android using the Epson Smart Panel app.

**Note:** Your device must be connected to the same wireless network as your Epson product, and Epson Smart Panel must be configured for use with your product.

1. Download the Epson Smart Panel app from your device's app store or from Epson's website. See the link below.
2. Open the Epson Smart Panel app and select a print menu on the home screen.
3. Follow the on-screen instructions to begin printing.

**Parent topic:** [Printing from a Computer](#)

**Related tasks**

[Using the Epson Smart Panel Mobile App](#)

## Printing with Epson Photo+

You can print photos, CD/DVD labels, and more using a variety of layouts and templates with Epson Photo+. Features include image corrections and adjustments, and adding text and stamps to photos. We recommend printing on genuine Epson photo paper for the best results. Make sure you have set up your product as described on the *Start Here* sheet and installed the Epson Photo+ software. See the Epson Photo+ help utility for more information.

**Note:** If you are using your Epson product with the Windows 10 S operating system, you cannot use Epson Photo+. You also cannot download and install any Epson product software from the Epson website for use with Windows 10 S; you must obtain software only from the Windows Store.

**Parent topic:** [Printing from a Computer](#)

**Related topics**

[Printing on CDs/DVDs](#)

## Cancelling Printing From the LCD Screen

If you need to cancel printing, select **Cancel** on the LCD screen.

**Parent topic:** [Printing from a Computer](#)

---

# Scanning

You can scan your originals and save them as digital files.

[Starting a Scan](#)

[Scanning a Document or Photo in Epson ScanSmart](#)

[Selecting Epson ScanSmart Settings](#)

[Scanning in Epson Scan 2](#)

## Starting a Scan

After placing your originals on your product for scanning, start scanning using one of these methods.

[Starting a Scan Using the Product Control Panel](#)

[Starting a Scan Using Epson ScanSmart](#)

[Starting a Scan Using the Epson Scan 2 Icon](#)

[Starting a Scan from a Scanning Program](#)

[Starting a Scan from a Smartphone or Tablet](#)

**Parent topic:** [Scanning](#)

## Starting a Scan Using the Product Control Panel

You can scan an image to a variety of destinations using your product's control panel.

1. Make sure you installed the product software and connected the product to your computer or network.

**Note:** Restart your computer after installing the product software to enable scanning from the control panel.

2. Place your original on the product for scanning.
3. Select the  home icon, if necessary.
4. Select **Scan**.



You see a screen like this:

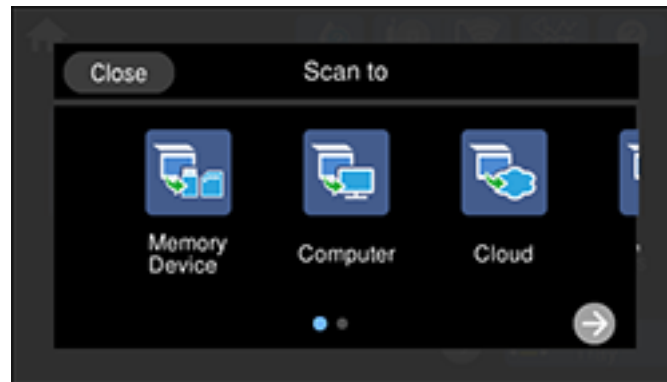

5. Select one of the following **Scan to** options:
  - **Memory Device** saves your scan file on a USB device or memory card and lets you select the file format, quality, and other settings.
  - **Computer** lets you scan to a connected computer using your saved scan settings.
  - **Cloud** sends your scanned files to a destination that you have registered with Epson Connect.
  - **WSD** lets you manage network scanning in Windows 10, Windows 8.x, Windows 7, or Windows Vista (English only). To use this feature, you must first set up a WSD (Web Services for Devices) port on your Windows 7 or Windows Vista computer (the port is set up automatically on Windows 10 and Windows 8.x).
6. Follow the instructions in the links below to complete your scan.

[Scanning to a Memory Device](#)

[Scanning to a Connected Computer](#)

[Scanning to the Cloud](#)

[Setting Up a WSD Port \(Windows 7/Windows Vista\)](#)

[Control Panel Scanning Options](#)

[Changing Default Scan Job Settings](#)

**Parent topic:** [Starting a Scan](#)

**Related topics**

[Placing Originals on the Product](#)

## Scanning to a Memory Device

You can scan an original and save the scanned image to a memory card or external USB device.

1. Insert a memory card into your product's memory card slot or connect an external USB device to the port on the front of the product.
2. Place your original on the product for scanning.
3. Select the  home icon, if necessary.
4. Select **Scan**.

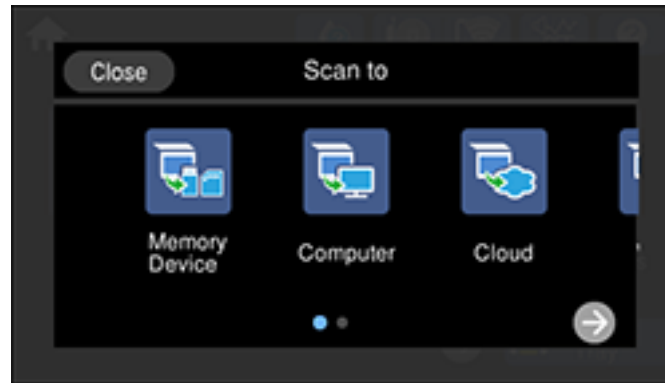

5. Select **Memory Device**.

You see a screen like this:

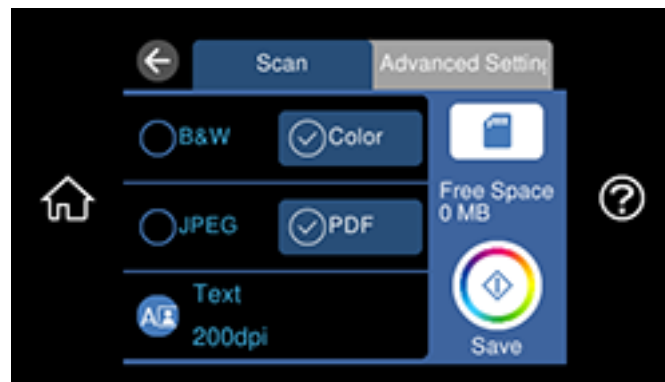

6. Change any of the displayed settings on the **Scan** tab as necessary.
7. Select the **Advanced Settings** tab to view and change additional scan settings, if necessary.
8. On the **Scan** tab, select the **Save** icon to start scanning.

Your product scans your original and saves the scanned file to the memory card or USB device.

**Parent topic:** [Starting a Scan Using the Product Control Panel](#)

#### **Related tasks**

[Inserting a Memory Card](#)

[Connecting and Using a USB Flash Drive or External Device](#)

#### **Related topics**

[Placing Originals on the Product](#)

### **Scanning to a Connected Computer**

You can scan an original and save it to a connected computer using your product's control panel. The computer must be connected using a USB cable or connected to the same network as your product.

You can save the scanned file as a JPEG or PDF file. You can also set up custom scan settings using Event Manager and automatically scan using those settings on your product control panel.

**Note:** Be sure you have installed Epson Scan 2, Epson ScanSmart, and Event Manager on your computer before scanning to your computer.

1. Place your original on the product for scanning.
2. Select the  home icon, if necessary.
3. Select **Scan**.

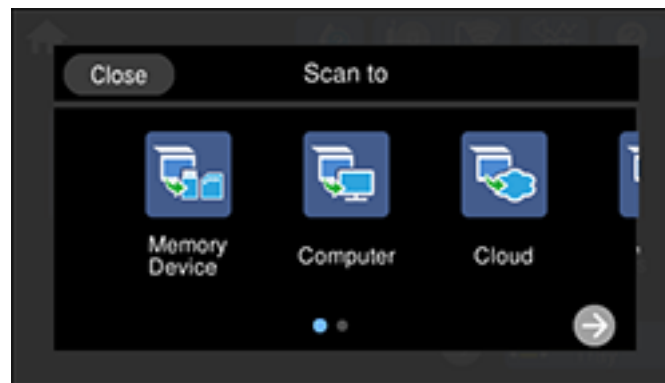

4. Select **Computer**.

You see a screen like this:

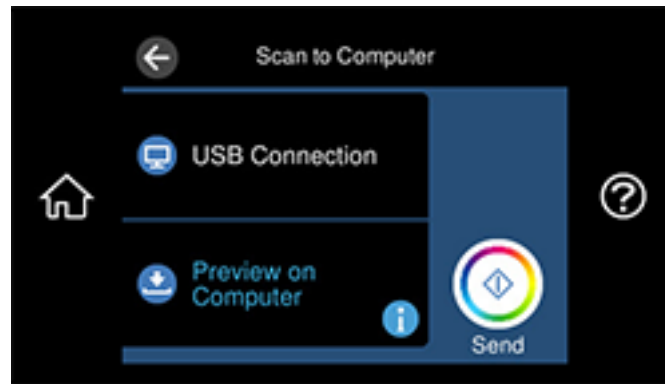

**Note:** Select **OK** to close the information screen, if necessary.

5. Select one of the following computer connections:

- If your computer is connected to your product using a USB cable, select **USB Connection**.

**Note:** Select **Select a computer** and select **USB Connection**, if necessary.

- If your computer is connected to your product over a network, select **Select a computer** and select your computer from the displayed list. (If the computer is not listed, select **Search Again**.)

**Note:** Select **USB Connection** and select a connected computer from the displayed list, if necessary.

6. Select **Save as PDF** and choose one of the following options:

- **Preview on Computer** to preview and edit the scan in Epson ScanSmart.
- **Save as JPEG** to save the scanned image as a JPEG file.
- **Save as PDF** to save the scanned document or image as a PDF file.

**Note:** You can customize the settings for each of the options above using Event Manager.

7. Select the **Send** or **Save** icon to start scanning.

Your product scans your original and saves the scanned file to your computer.

**Parent topic:** [Starting a Scan Using the Product Control Panel](#)

**Related tasks**

[Changing Default Scan Job Settings](#)

**Related topics**

[Placing Originals on the Product](#)

### Scanning to the Cloud

You can use the control panel to send your scanned files to a destination that you have registered with Epson Connect.

**Note:** Make sure to set up your product using Epson Connect before using this feature.

1. Place your original on the product for scanning.
2. Press the  home icon, if necessary.
3. Select **Scan**.

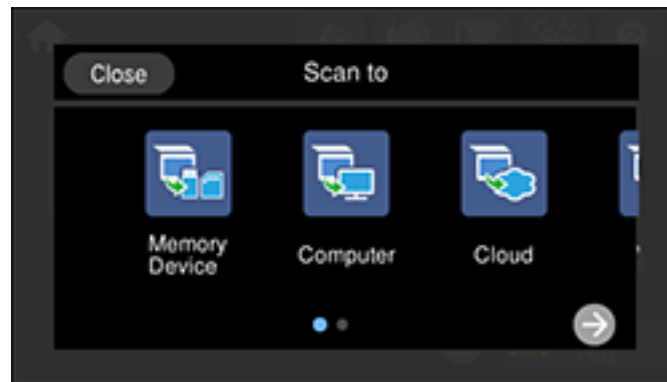

4. Select **Cloud**.

You see a screen like this:



**Note:** You must register your product with Epson Connect to select a destination.

5. Select **Select Destination** to select a destination.
6. Change any of the displayed settings on the **Scan** tab as necessary.
7. Select the **Advanced Settings** tab to view and change additional scan settings, if necessary.
8. On the **Scan** tab, select the **Upload** icon to start scanning.

Your product scans your original and saves the scanned file to the selected destination.

**Parent topic:** [Starting a Scan Using the Product Control Panel](#)

#### **Related tasks**

[Setting Up Epson Connect Services](#)

#### **Related topics**

[Placing Originals on the Product](#)

### **Setting Up a WSD Port (Windows 7/Windows Vista)**

You can scan to a networked Windows computer using WSD (Web Services for Devices). You must first set up a WSD port on your Windows 7 or Windows Vista system (the port is set up automatically on Windows 10 and Windows 8.x).

Before you set up a WSD port, make sure you installed your product software, and connected your product and computer to the same network.

1. Turn on your product.

2. Print a network status sheet so you can identify the network name and model name for your product on the network.
3. Click  or **Start** and select **Computer**.
4. On the left side of the window, select **Network**.
5. Locate your product on the Network screen, right-click it, and select **Install**.
6. When you see the User Account Control screen, click **Continue**.

**Note:** If you see an Uninstall screen, click **Uninstall** and repeat these steps as necessary.

7. When you see the message **Your device is ready to use** in the Windows taskbar, click the message.
8. On the Driver Software Installation screen, make sure your product is listed as **Ready to use**. Then click **Close**.
9. Do one of the following:
  - **Windows 7:** Click  and select **Devices and Printers**.
  - **Windows Vista:** Click **Start** and select **Control Panel > Hardware and Sound > Printers**.
10. Make sure that an icon appears for your product's name on the network.

When you use WSD, select your product name to scan over the network.

**Parent topic:** [Starting a Scan Using the Product Control Panel](#)

#### **Related tasks**

[Printing a Network Status Sheet](#)

### **Control Panel Scanning Options**

Select the options you want to use for scanning.

**Note:** Not all options or settings may be available, depending on the **Scan to** option selected.



<b>Scan to setting</b>	<b>Available options</b>	<b>Description</b>
<b>Color Mode</b>	<b>Color</b>	Select whether to scan images in color or black and white
	<b>B&amp;W</b>	

Scan to setting	Available options	Description
<b>File Format</b>	<b>JPEG</b>	Select for photos
	<b>PDF</b>	Select for documents
<b>Original Type</b>	<b>Text</b>	Specifies the type of original you are scanning. You can also select the resolution.
	<b>Photo</b>	
<b>Scan Settings</b>	Various sizes	Select the page size for documents. You can also select the orientation of the original.
	<b>Auto Cropping</b>	Select for photos with dark edges
	<b>Max Area</b>	Select for most photos
<b>Contrast</b>	Varying levels	Adjusts the lightness or darkness of scanned images
<b>Select Memory Device</b>	<b>Memory Card</b>	Select the currently inserted device to scan to
	<b>USB Memory</b>	
<b>Clear All Settings</b>	<b>Yes</b>	Restores all scan settings to their defaults
	<b>No</b>	

Parent topic: [Starting a Scan Using the Product Control Panel](#)

### Changing Default Scan Job Settings

You can view or change the default scan job settings your product uses when you scan to your computer. You do this using the Event Manager program.

- Do one of the following to open Event Manager:
  - Windows 10:** Click  and select **Epson Software > Event Manager**.
  - Windows 8.x:** Navigate to the **Apps** screen and select **Event Manager**.
  - Windows (other versions):** Click  or **Start > All Programs** or **Programs > Epson Software > Event Manager**.
  - Mac:** Open the **Applications** folder, click **Epson Software**, and select **Event Manager**.
- Open the **Scanner** (Windows) or **Select Scanner** (Mac) drop-down list and select your product, if necessary.
- Click **Make Job Settings**.





4. Open the **Edit Job Settings** drop-down list and select the scan job settings you want to view or change.
5. Change the settings as necessary.
6. Click **OK**.
7. Click **Close** to close the Event Manager window.

Parent topic: [Starting a Scan Using the Product Control Panel](#)

## Starting a Scan Using Epson ScanSmart

You can start the Epson ScanSmart program to scan originals and easily review and edit scanned images. After that, you can save, print, or share them.

- **Windows 10:** Click  > **Epson Software** > **Epson ScanSmart**.
- **Windows 8.x:** Navigate to the **Apps** screen and select **Epson ScanSmart**.
- **Windows (other versions):** Click  or **Start**, and select **All Programs** or **Programs**. Select **Epson Software** > **Epson ScanSmart**.
- **Mac:** Open the **Applications** folder, open the **Epson Software** folder, and select **Epson ScanSmart**.

You see a screen like this:

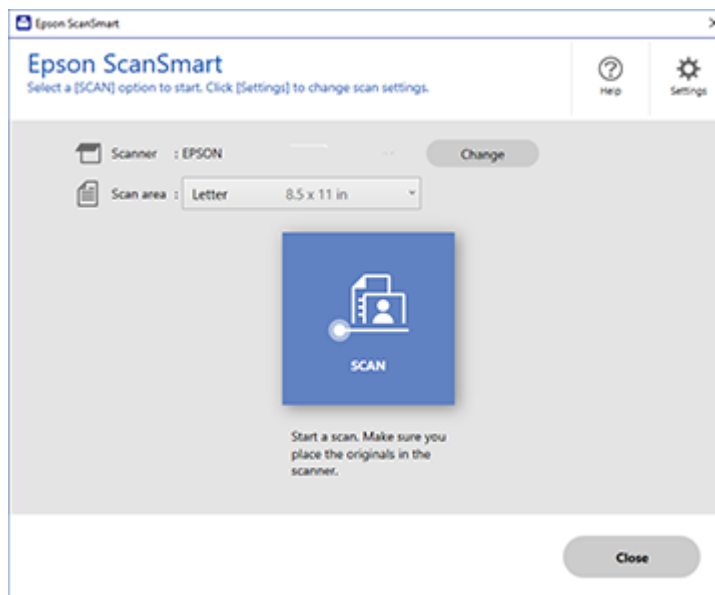



Parent topic: [Starting a Scan](#)

## Starting a Scan Using the Epson Scan 2 Icon

You can start the Epson Scan 2 program to select scan settings, scan, and save the scanned image to a file.

**Note:** If you are using your Epson product with the Windows 10 S operating system, you cannot use the software described in this section. You also cannot download and install any Epson product software from the Epson website for use with Windows 10 S; you must obtain software only from the Windows Store.

- **Windows 10:** Click  and select **EPSON > Epson Scan 2**.
- **Windows 8.x:** Navigate to the **Apps** screen and select **Epson Scan 2**.
- **Windows (other versions):** Click  or **Start**, and select **All Programs** or **Programs**. Select **EPSON > Epson Scan 2 > Epson Scan 2**.
- **Mac:** Open the **Applications** folder, open the **Epson Software** folder, and select **Epson Scan 2**.

You see an Epson Scan 2 window like this:

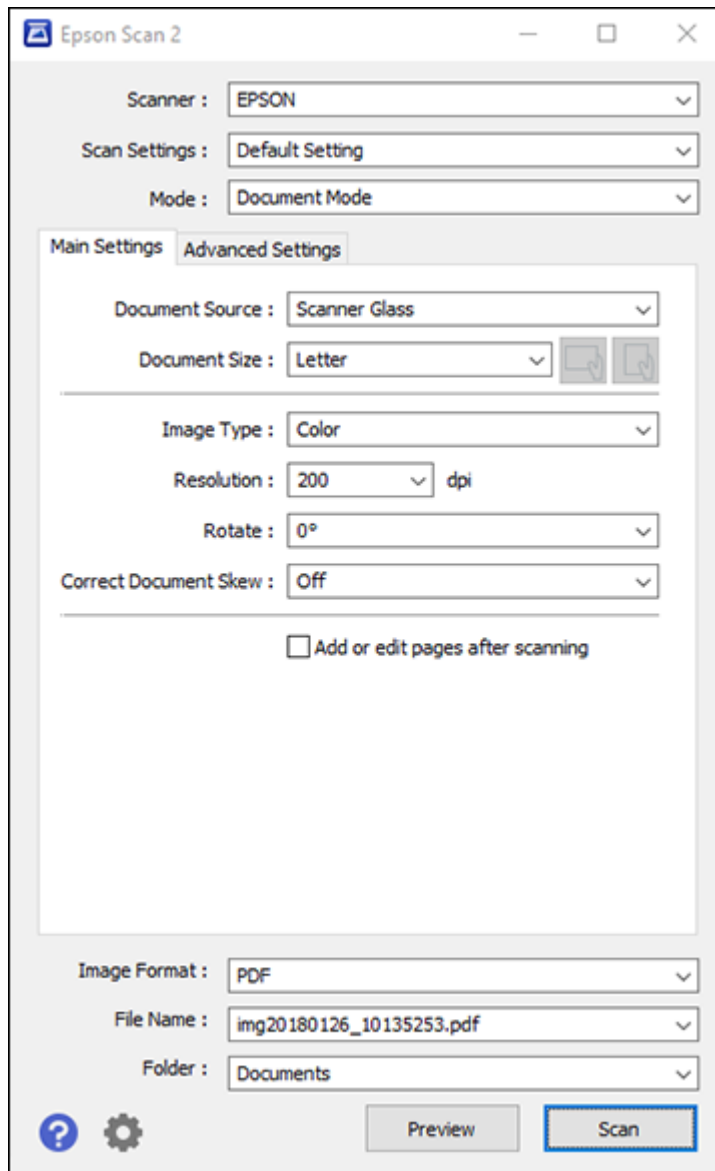

Parent topic: [Starting a Scan](#)

## Starting a Scan from a Scanning Program

You can start Epson Scan 2 from a TWAIN-compliant scanning program to select scan settings, scan, and open the scanned image in the program.

**Note:** If you are using your Epson product with the Windows 10 S operating system, you cannot use the software described in this section. You also cannot download and install any Epson product software from the Epson website for use with Windows 10 S; you must obtain software only from the Windows Store.

1. Open your scanning program and select its scanning option. (See your scanning program help for instructions.)
2. Select your product.

**Note:** In certain programs, you may need to select your product as the "source" first. If you see a **Select Source** option, choose it and select your product. With Windows, do not select a **WIA** option for your product; not all scan functions will be available.

You see an Epson Scan 2 window like this:

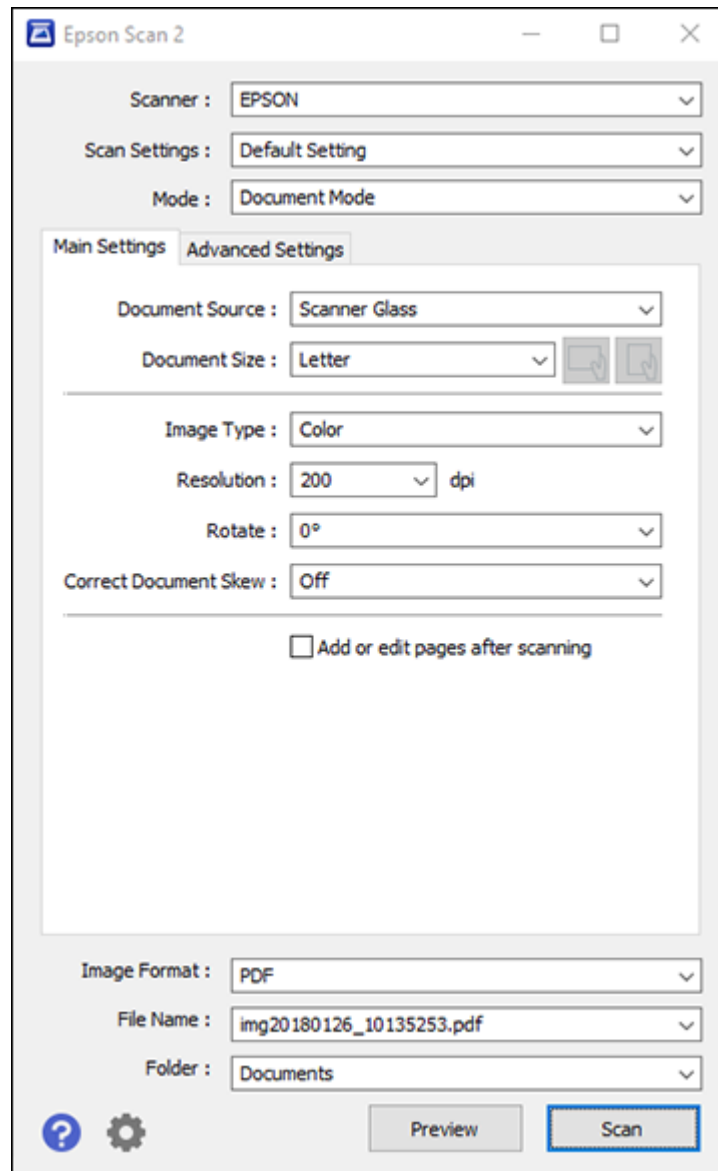

Parent topic: [Starting a Scan](#)

## Starting a Scan from a Smartphone or Tablet

You can use the Epson Smart Panel app to scan from a network scanner to an iOS or Android device over a direct Wi-Fi connection.

1. Download the Epson Smart Panel app from your device's app store or from Epson's website. See the link below.
2. Place your original on the product for scanning.
3. Open the Epson Smart Panel app and select a scan menu on the home screen.
4. Follow the on-screen instructions to scan and save your original.

Parent topic: [Starting a Scan](#)



### Related tasks

[Using the Epson Smart Panel Mobile App](#)

## Scanning a Document or Photo in Epson ScanSmart

You can scan and review documents and photos in Epson ScanSmart.

**Note:** The images in this guide show Windows screens. Mac screens may be slightly different. Depending on your product model and software version, not all options may be available.

1. Place your original on the product for scanning.
2. Open Epson ScanSmart on your computer. Do one of the following:
  - **Windows 10:** Click  > **Epson Software** > **Epson ScanSmart**.
  - **Windows 8.x:** Navigate to the **Apps** screen and select **Epson ScanSmart**.
  - **Windows (other versions):** Click  or **Start**, and select **All Programs** or **Programs**. Select **Epson Software** > **Epson ScanSmart**.
  - **Mac:** Open the **Applications** folder, open the **Epson Software** folder, and select **Epson ScanSmart**.

You see a screen like this:

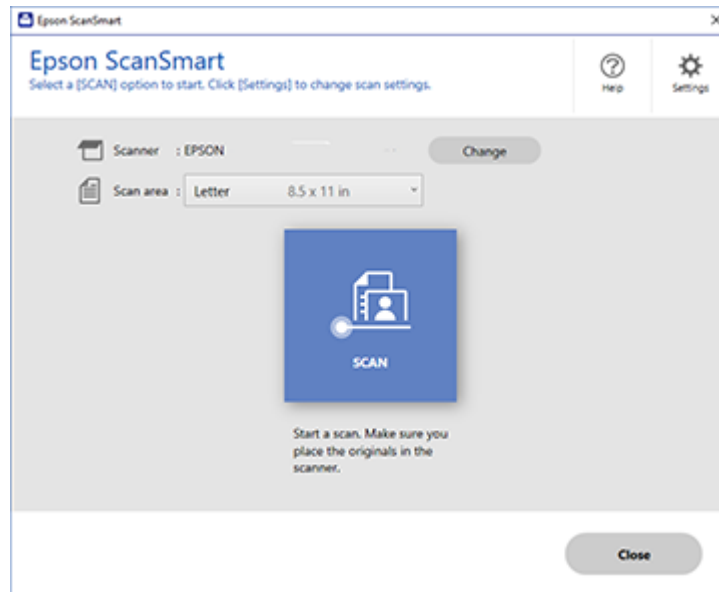

3. Select an option for the **Scan area** setting, if necessary.

**Note:** The **Scan area** setting limits the scan area to a selected size starting at the placement arrow on the scanner bed. It does not scale the image to the selected size.

4. Select **SCAN**.

The original is scanned. When scanning is complete, you see a screen like this:

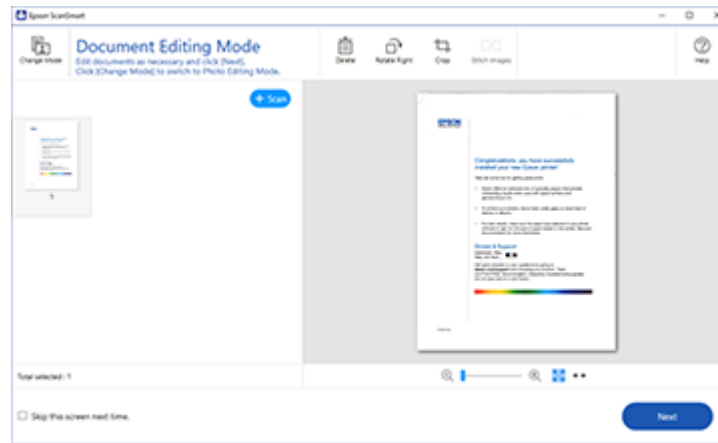

**Note:** To change between document or photo editing options, select **Change Mode**.

5. In Document Editing Mode, you can review, edit, or reorder the scanned images as follows:
  - Select **+ Scan** to scan more originals.
  - Select **Delete** to delete selected scanned images.
  - Select **Rotate Right** to rotate each scanned image.
  - Select **Crop** to crop the selected image.
  - Control-click two images, select **Stitch Images**, and follow the on-screen instructions to combine them into a single image.
6. In Photo Editing Mode, the following enhancement options are available:
  - **Auto Color Enhancement:** automatically adjusts the brightness, contrast, and saturation of your photos
  - **Restore Faded Colors:** restores the colors in faded photos automatically
  - **Remove Red Eye:** automatically removes the red-eye effect from your photos
  - **Auto Cropping:** automatically crops the scanned image edges
7. When you finish reviewing and editing the scanned images, click **Next**.



You see a screen like this:

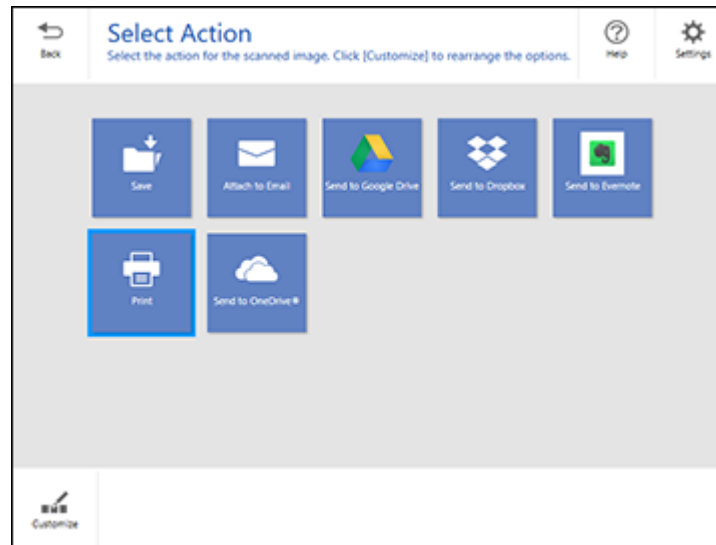

8. Select an option to save, send, or print the scanned images. See the links below.

[Saving a Scan](#)

[Attaching a Scan to Email](#)

[Sending a Scan to a Cloud Service](#)

[Printing a Scan](#)

**Parent topic:** [Scanning](#)

## **Saving a Scan**

You can save a scanned image to your computer in a variety of formats.

1. Make sure your originals are scanned and reviewed. See the link below.
2. In the **Select Action** window, click **Save**.

You see a screen like this:

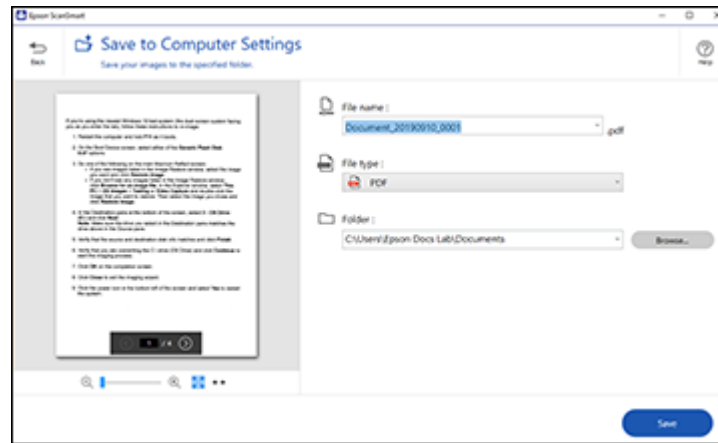

3. Change the settings as follows:
  - The document type and scan date for the file name are automatically detected. You can change them as necessary.
  - You can save the scanned image in a variety of formats. If you select Searchable PDF as the **File type** setting, you can select the OCR (Optical Character Recognition) language.
  - Select the folder on your computer in which to save the file.
4. Click **Save**.

**Parent topic:** [Scanning a Document or Photo in Epson ScanSmart](#)

## Attaching a Scan to Email

You can attach a scanned image to an email as a file attachment.

**Note:** Your email app and account settings should be configured before scanning. You must install a MAPI-type email program such as Outlook Express, Windows Live Mail, Entourage, or Mac Mail. Attach to Email only supports 32-bit MAPI-compatible mail apps. Web-based email services such as Gmail are not supported. If you see an error message, your email app may not be compatible and you will need to save the scans and manually attach the file to an email.

1. Make sure your originals are scanned and reviewed. See the link below.

2. In the **Select Action** window, click **Attach to Email**.

You see a screen like this:

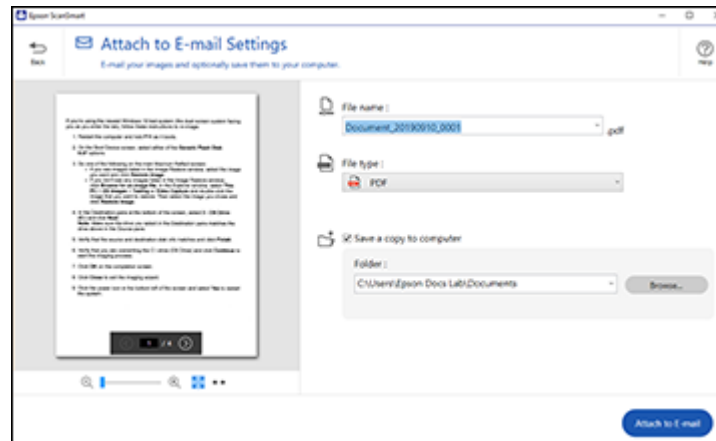

3. Change the settings as follows:
  - The document type and scan date for the file name are automatically detected. You can change them as necessary.
  - You can save the scanned image in a variety of formats. If you select Searchable PDF as the **File type** setting, you can select the OCR (Optical Character Recognition) language.
  - If you also want to save a copy of the scanned image to your computer, make sure the checkbox is selected and select the folder on your computer in which to save the file.
4. Click **Attach to E-mail**.

Your email program opens with the file attached to a new email.

**Parent topic:** [Scanning a Document or Photo in Epson ScanSmart](#)

## Sending a Scan to a Cloud Service

You can upload scanned images to a cloud service.

1. Make sure your originals are scanned and reviewed. See the link below.
2. In the **Select Action** window, click one of the cloud service send options.

You see a screen like this:

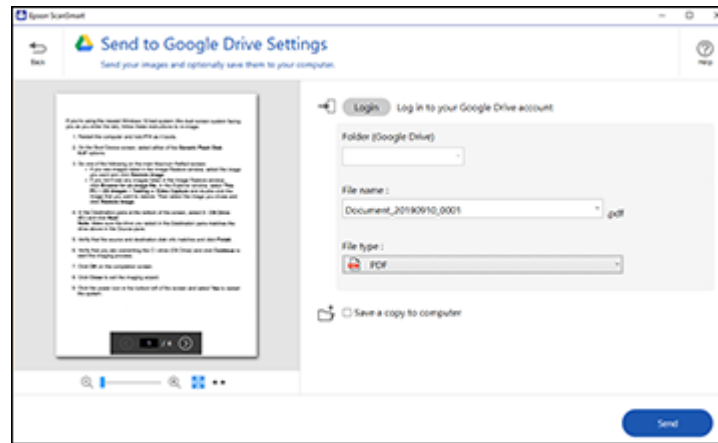

3. Log in to your account.

**Note:** You may need to allow Epson ScanSmart access to your account. The first time you log in, you may be prompted to enter an authentication code.

4. Change the settings as follows:
  - Select the folder in your account where you want to send the document.
  - The document type and scan date for the file name are automatically detected. You can change them as necessary.
  - You can save the scanned image in a variety of formats. If you select Searchable PDF as the **File type** setting, you can select the OCR (Optical Character Recognition) language.
  - If you also want to save a copy of the scanned image to your computer, click the checkbox.
5. Click **Send**.

**Parent topic:** [Scanning a Document or Photo in Epson ScanSmart](#)

## Printing a Scan

You can print your scanned image and save the scanned file to your computer.

**Note:** Printing scanned images is available only with Epson printers. If you do not have an Epson printer, save the file and print it from an application that can open the file.

1. Make sure your originals are scanned and reviewed. See the link below.
2. In the **Select Action** window, click **Print**.

You see a screen like this:

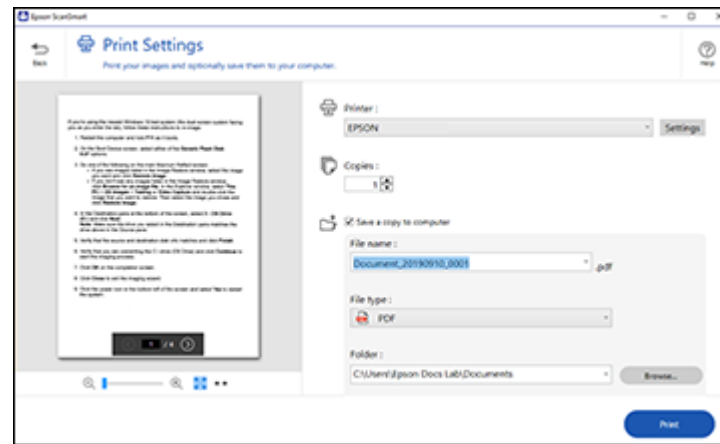

3. Change the settings as follows:
  - Select the Epson printer and change the print settings, if necessary.
  - Select the number of copies you want to print.
  - If you also want to save a copy of the scanned image to your computer, click the checkbox.
  - The document type and scan date for the file name are automatically detected. You can change them as necessary.
  - You can save the scanned image in a variety of formats. If you select Searchable PDF as the **File type** setting, you can select the OCR (Optical Character Recognition) language.
  - Select the folder on your computer in which to save the file.
4. Click **Print**.

**Parent topic:** [Scanning a Document or Photo in Epson ScanSmart](#)

## Selecting Epson ScanSmart Settings

After starting Epson ScanSmart, you can change various scanning settings.

[Changing the Epson Product](#)

[Changing the Scan Settings](#)

[Changing the File Name Settings](#)

[Changing the Save Settings](#)

[Customizing Action Icons](#)

**Parent topic:** [Scanning](#)

## Changing the Epson Product

If you are using more than one Epson product with Epson ScanSmart, you can change the product that you are using with your computer.

**Note:** A product connected to your computer via USB takes priority over a product with a Wi-Fi connection.

1. On the main screen, click **Change**.

You see a screen like this:

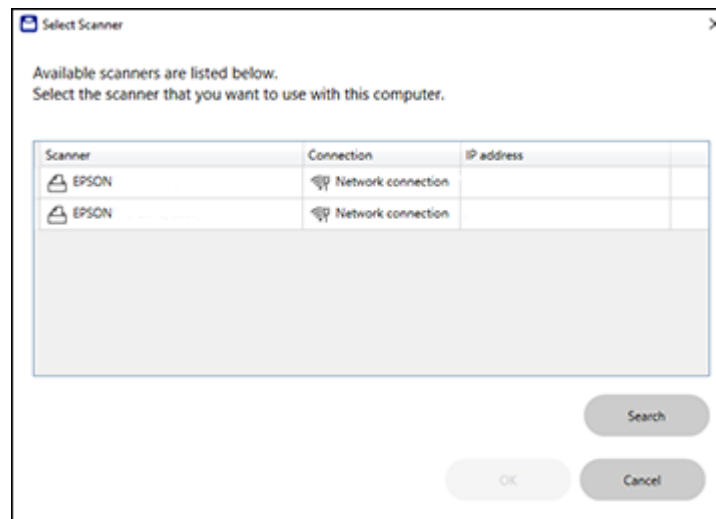

2. Select the Epson product you want to use with your computer and click **OK**.

**Parent topic:** [Selecting Epson ScanSmart Settings](#)

## Changing the Scan Settings

You can change detailed scan settings such as the resolution, document size, and more.

**Note:** If you select **Auto Mode**, you cannot change the scan settings.

1. Click the  **Settings** button.

You see a screen like this:

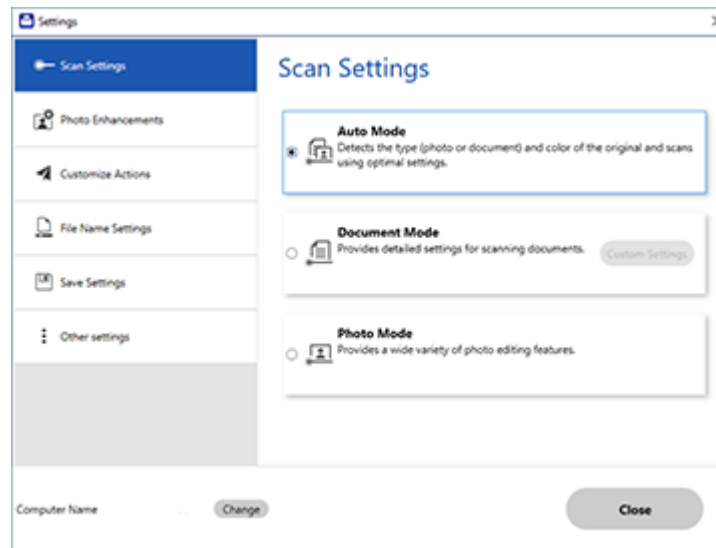

2. Do one of the following:

- To change Document Mode settings, select **Document Mode > Custom Settings**.
- To change Photo Mode settings, select **Photo Mode** and click **Close**. When you start a scan, you will be prompted to select scan settings.

You see a screen like this:

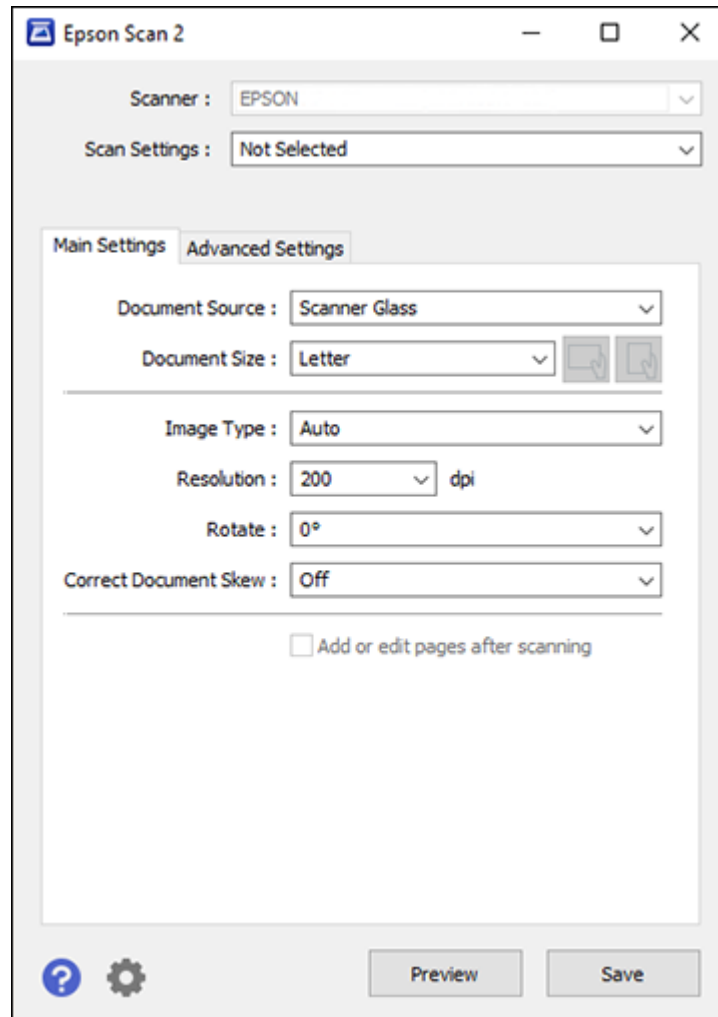

3. Change the settings as necessary and click **Save**.

**Parent topic:** [Selecting Epson ScanSmart Settings](#)



## Changing the File Name Settings

You can change the default file naming method for your scans.

1. Click the  **Settings** button.

You see a screen like this:

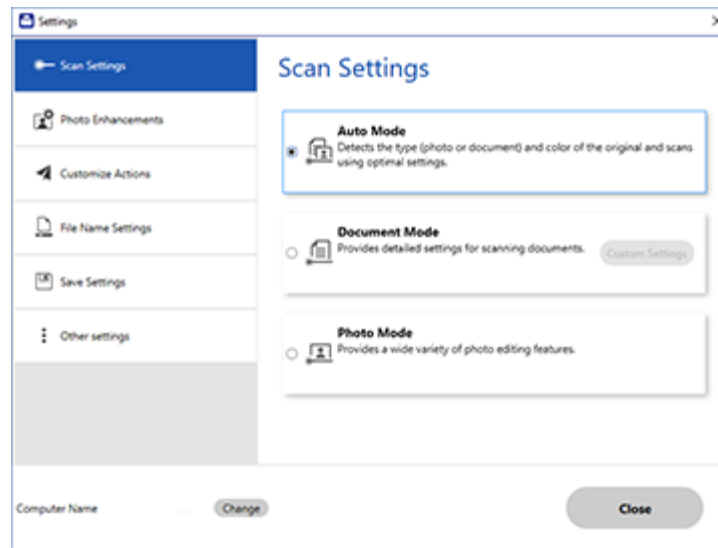

2. Click the **File Name Settings** tab.

You see a screen like this:

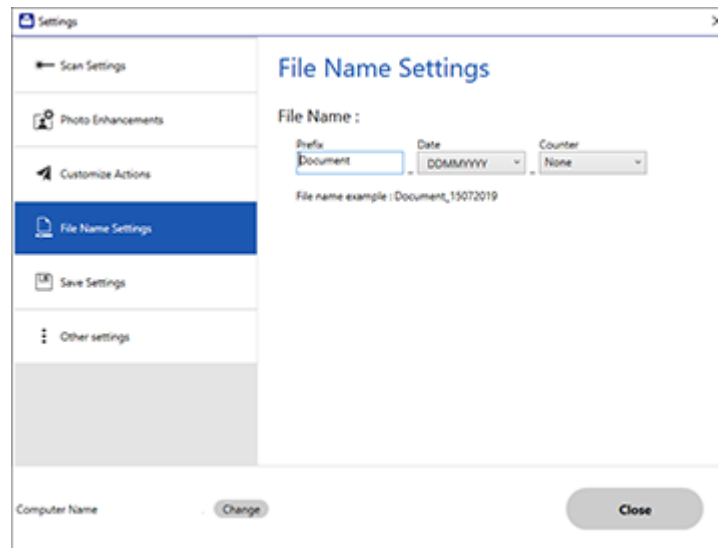

3. Change the settings as necessary:
  - Enter a prefix for the file name.
  - Select the date format.
  - Select a numbering format as the counter format.

4. Click **Close**.

**Parent topic:** [Selecting Epson ScanSmart Settings](#)

## Changing the Save Settings

You can change the file type options for saving your scans.

1. Click the  **Settings** button.

You see a screen like this:

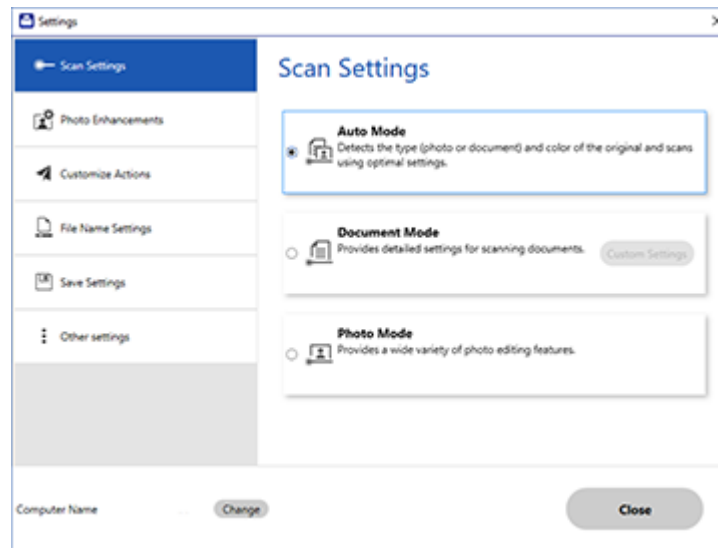

2. Click the **Save Settings** tab.

You see a screen like this:

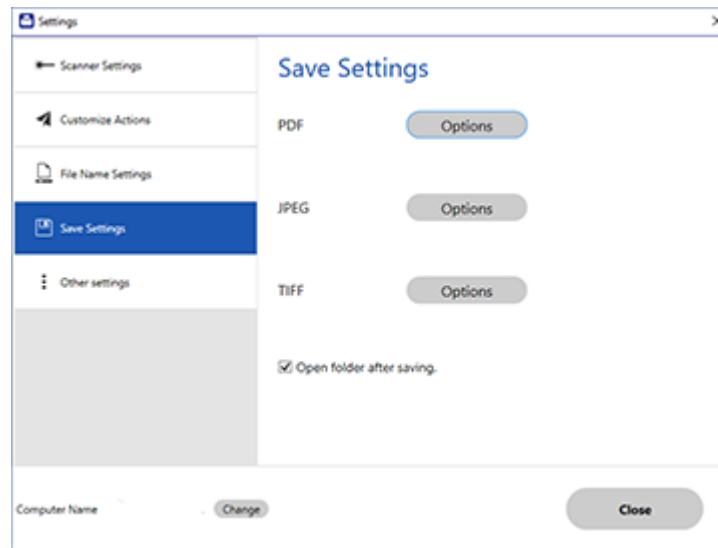

3. Click **Options** for a file format and change the settings as necessary.
4. Click **Open folder after saving** to open the file folder after a file is saved.
5. Click **Close**.

[Save Settings](#)

**Parent topic:** [Selecting Epson ScanSmart Settings](#)

## Save Settings

You can change the settings for how scanned images are saved.

### PDF Options

Setting	Options	Description
<b>General</b>	<b>Generate PDF/A File</b>	Creates a PDF that conforms to PDF/A-1 standards
	<b>Create file with all pages</b>	Saves all pages as one file
	<b>Compression Level</b>	Selects the compression level for color or grayscale images

### JPEG Options

Setting	Options	Description
<b>Image Quality Options</b>	—	Sets a compression level by moving a slider or entering a value. File size increases the higher the resolution is.
<b>Encoding</b> (Windows only)	<b>Standard</b>	Images load from top to bottom in a web browser. It takes longer to load the entire image.
	<b>Progressive</b>	Images first load completely at low resolution and then adjust to high resolution in a web browser
<b>Embed ICC Profile</b> (Windows only)	—	Allows you to add ICC profiles to the image

### TIFF Options

Setting	Options	Description
<b>Byte Order</b>	<b>Windows</b> <b>Macintosh</b>	Specifies the operating system where the scanned image will be used
<b>Compression</b> (Windows only)	—	Specifies the compression format and level for Color/Grayscale and B&W images. File size increases with higher quality.
<b>Embed ICC Profile</b> (Windows only)	—	Allows you to add ICC profiles to the image

Parent topic: [Changing the Save Settings](#)

## Customizing Action Icons

You can customize which scan action icons appear on the **Select Action** screen.

**Note:** You can also customize them by clicking the **Customize** icon on the **Select Action** screen.

1. Click the  **Settings** button.

You see a screen like this:

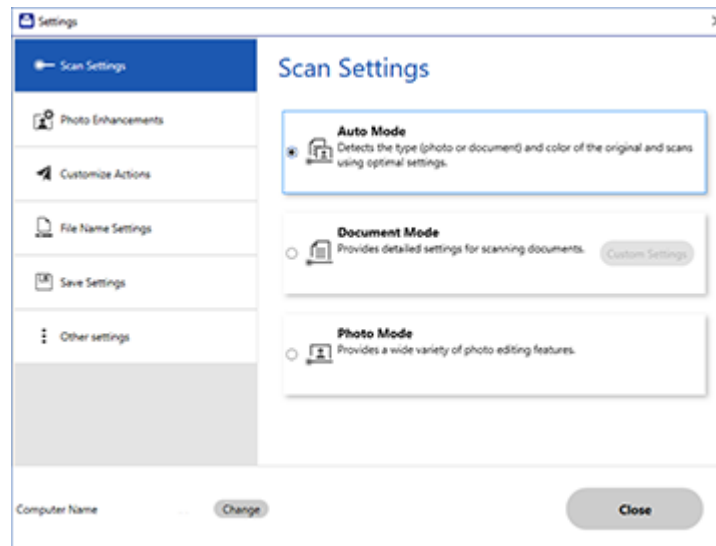

2. Click the **Customize Actions** tab.

You see a screen like this:

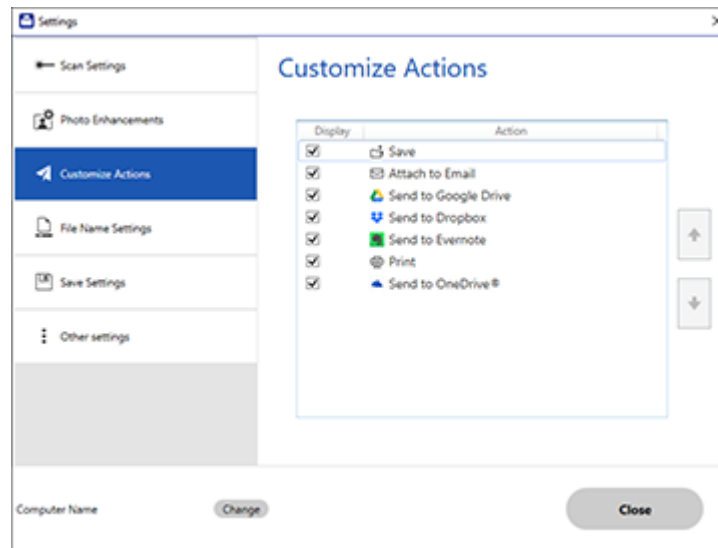

3. Choose which action icons to display by selecting or deselecting each checkbox. Click the arrow icons to move the icons up or down in the display order you want.
4. Click **Close**.

**Parent topic:** [Selecting Epson ScanSmart Settings](#)

## Scanning in Epson Scan 2

Epson Scan 2 gives you access to basic and advanced scanning features. You can scan your document and save the scanned image in various file formats in your operating system's Documents or My Documents folder, or open it in your scanning program. You can preview the scanned image and select or change settings as necessary.

**Note:** If you are using your Epson product with the Windows 10 S operating system, you cannot use the software described in this section. You also cannot download and install any Epson product software from the Epson website for use with Windows 10 S; you must obtain software only from the Windows Store.

1. Start Epson Scan 2.

You see this window:

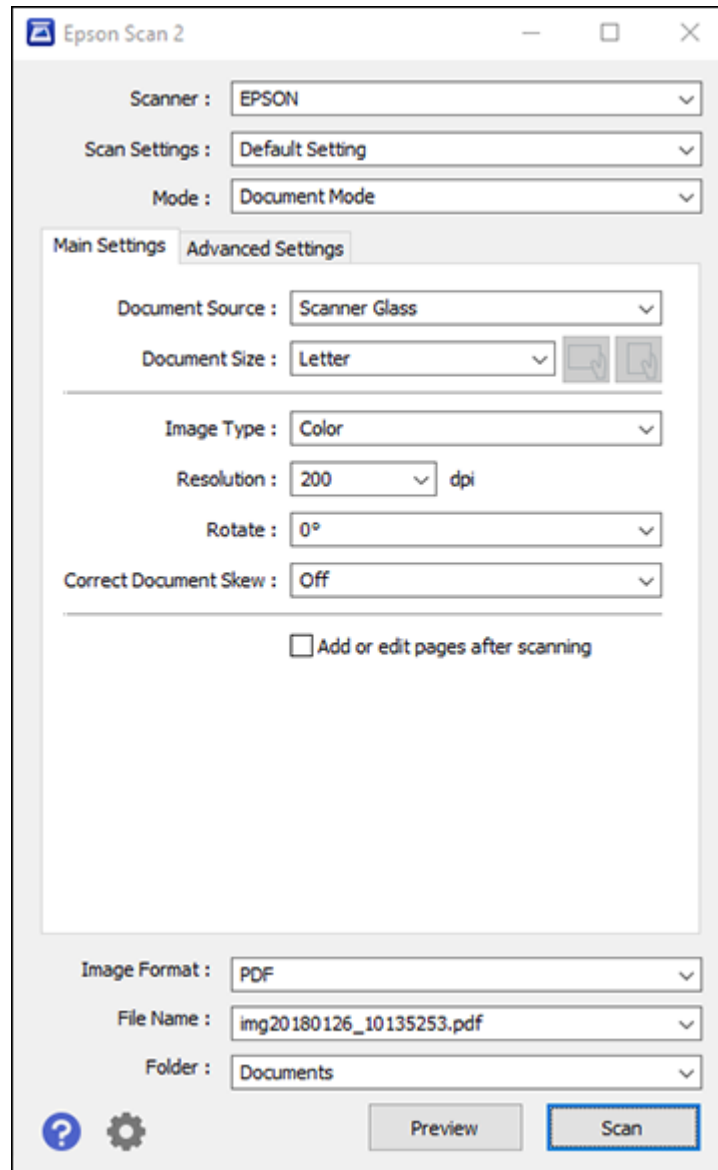



2. Select the **Mode** setting that matches the type of original you are scanning.
3. Select the **Document Source** setting that matches where you placed your original.
4. Select the **Document Size** setting that matches the size of your original. You can select **Customize** to enter a custom size, if necessary.
5. Select the image type of your original and how you want it scanned as the **Image Type** setting.
6. Select the **Resolution** setting you want to use for your scan.
7. Select the **Rotate** setting to rotate the scanned image.
8. Select the **Correct Document Skew** setting to correct skewed originals, image contents, or both.
9. Click the **Preview** button.

Epson Scan 2 previews your original and displays the results in the Epson Scan 2 window.

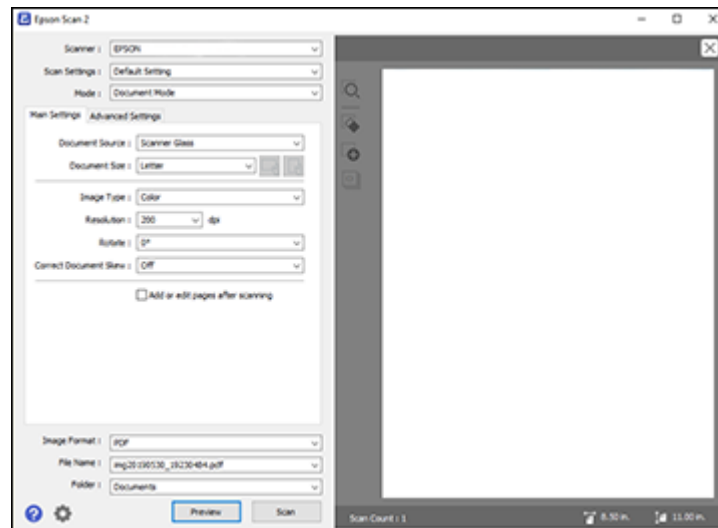

10. Do one of the following:
  - If you're scanning in Document Mode, select any of the additional settings that you want to use on the Main Settings tab.
  - If you're scanning in Photo Mode, select the **Color Management** and **Thumbnail Options** settings as necessary.
11. Click the **Advanced Settings** tab and select any settings that you want to use.

12. Select the format in which you want to save your scanned file as the **Image Format** setting. If necessary, select **Options** and select any desired format options.
13. Enter the file name for your scanned file in the **File Name** field. If necessary, select **Settings** to modify the file name settings.
14. Select the location in which you want to save your scanned file as the **Folder** setting. If necessary, select **Select** to create a new folder.
15. Click **Scan**.

The product scans your original and saves the scanned file in the location you specified.

[Additional Scanning Settings - Main Settings Tab](#)

[Additional Scanning Settings - Advanced Settings Tab](#)

[Saving Scanned Documents as a Searchable PDF Using Epson Scan 2](#)

[Image Format Options](#)

[Scan Resolution Guidelines](#)

**Parent topic:** [Scanning](#)

## Additional Scanning Settings - Main Settings Tab

You can select these additional scanning settings on the Epson Scan 2 Main Settings tab. Not all adjustment settings may be available, depending on other settings you have chosen.

### **Rotate**

Rotates the original image clockwise to the desired angle before scanning it. Select **Auto** to allow your product to automatically rotate the image based on the orientation of the text (may take longer to scan).

### **Correct Document Skew**

Corrects skewed originals, image contents, or both.

### **Add or edit pages after scanning**

Lets you add, remove, or edit the pages in a scan, including rotating pages and changing the page order.

**Note:** To save multiple pages in a single file, you must select a file format that supports multiple pages such as **PDF** or **Multi-TIFF**. If you select another file format, each scanned image or page is saved as a separate file.

**Parent topic:** [Scanning in Epson Scan 2](#)

## Additional Scanning Settings - Advanced Settings Tab

You can select these additional scanning settings on the Epson Scan 2 Advanced Settings tab. Not all adjustment settings may be available, depending on other settings you have chosen.

### **Remove Background**

Removes the background of the originals.

### **Text Enhancement**

Sharpens the appearance of letters in text documents.

### **Auto Area Segmentation**

Makes black and white images clearer and text recognition more accurate by separating the text from the graphics.

### **Threshold**

Adjusts the level at which black areas in text and line art are delineated, improving text recognition in OCR (Optical Character Recognition) programs.

### **Color Enhance**

Enhances the shades of the color you select in the scanned image. This setting is available only if you select **Grayscale** or **Black & White** as the Image Type setting.

### **Brightness**

Adjusts the overall lightness and darkness of the scanned image.

### **Contrast**

Adjusts the difference between the light and dark areas of the overall scanned image.

### **Saturation**

Adjusts the density of colors in the overall image.

### **Gamma**

Adjusts the midtone density of the scanned image.

### **Unsharp Mask**

Makes the edges of certain image areas clearer. Turn off this option to leave softer edges.

### **Descreening**

Removes the ripple pattern that might appear in subtly shaded image areas, such as skin tones. This option improves results when scanning magazines or newspapers. (The results of descreening do not appear in the preview image, only in your scanned image.)

### **Color Restoration**

Corrects color in faded images (when scanning in Photo Mode).

### **Backlight Correction**

Lightens darkly backlit images (when scanning in Photo Mode).

**Dust Removal**

Removes dust on scanned images (when scanning in Photo Mode).

**Edge Fill**

Corrects shadowing around the edges of the image by filling the shadows with black or white.

**Dual Image Output**

Scans the original image twice using different output settings (Windows only).

**Watermark**

Adds a watermark to a scanned image.

Parent topic: [Scanning in Epson Scan 2](#)

## Saving Scanned Documents as a Searchable PDF Using Epson Scan 2

You can scan a document and save the text in a searchable PDF. In a searchable PDF, text is recognized using Optical Character Recognition (OCR) and then embedded in the scanned original.

**Note:** The required Epson Scan 2 OCR Component is installed automatically when you install your product software as instructed on the *Start Here* sheet. If you install your scanner software programs individually, be sure to also install this component if you want to perform OCR.

1. Load your original in the product for scanning.
2. Start Epson Scan 2.
3. Select your scan settings.
4. Click **Preview** and adjust the area you want to scan, if necessary.
5. Select **Searchable PDF** as the Image Format setting.
6. Select **Options** from the Image Format list.

You see this window:

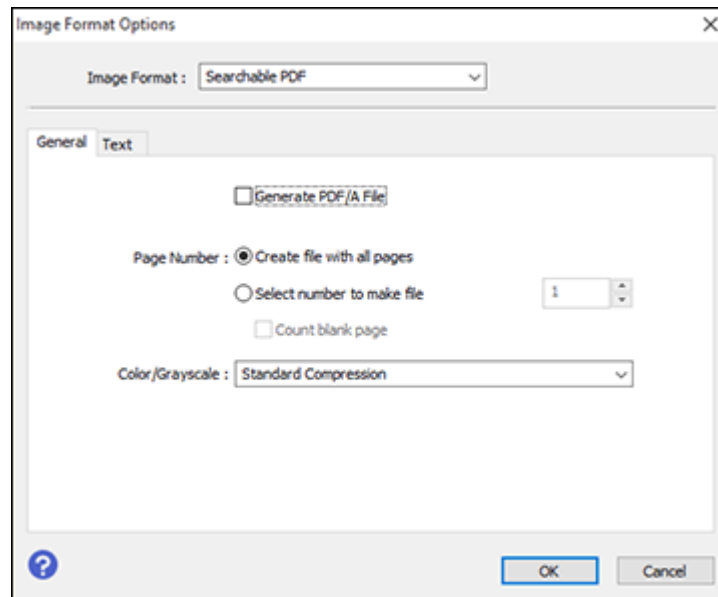

7. Select any of the options on the General tab.
8. Select the **Text** tab.
9. Make sure the language used in the document text is selected as the **Text Language** setting.
10. Click **OK**.
11. Confirm the **File Name** setting and select a **Folder** setting for your document.
12. Click **Scan**.

The scanned image is saved as a searchable PDF.

Parent topic: [Scanning in Epson Scan 2](#)

## Image Format Options

You can select different image formats and related options. For details on available options, click the ? icon on the Epson Scan 2 Image Format Options window. Not all image formats have options.

### **BITMAP (\*.bmp)**

A standard image file format for most Windows programs.

**JPEG (\*.jpg)**

An image format that lets you highly compress image data. However, the higher the compression, the lower the image quality. (The TIFF format is recommended when you need to modify or retouch your scanned image.)

**PNG (\*.png)**

An image format that does not lose quality during editing.

**TIFF (\*.tif)**

A file format created for exchanging data between many programs, such as graphic and DTP software.

**Multi-TIFF (\*.tif)**

A TIFF file format when multiple pages are saved to the same file, allowing you to edit the images using a compatible program.

**PDF (\*.pdf)**

A document format that is readable by Windows and Mac systems using Adobe Reader, Acrobat, or other programs. You can save multi-page documents in one PDF file.

**Searchable PDF (\*.pdf)**

A document format that is readable by Windows and Mac systems using Adobe Reader, Acrobat, or other programs. You can save multi-page documents in one PDF file. Recognized text in the scanned document can be searched.

Parent topic: [Scanning in Epson Scan 2](#)

## Scan Resolution Guidelines

The **Resolution** setting, measured in dpi (dots per inch), controls the amount of detail captured in your scans. Increasing the resolution raises the amount of detail captured but comes with the following disadvantages:

- Larger file sizes
- It takes longer to scan your originals, send/receive your scans by email or fax, and to print your scans
- The image may become too large to fit on your display or print on paper

If you plan to enlarge a scanned image so you can print it at a larger size, you may need to increase the resolution from the default resolution set by Epson Scan 2. Follow these guidelines to determine the resolution setting you need:

- You will scan the image at its original size but enlarge it later in an image-editing program.

Increase the Epson Scan 2 Resolution setting in your scan. Increase the resolution by the same amount you will increase the image size to retain a high image quality. For example, if the resolution is

300 dpi (dots per inch) and you will double the image size later, change the Resolution setting to 600 dpi.

- You will scan the image at 100% or a smaller size.

Select the Epson Scan 2 Resolution setting based on how you will use the scanned image:

- Email/view on a computer screen/post on the web: 96 to 200 dpi
- Print/fax/convert to editable text (OCR)/create searchable PDF: 200 to 300 dpi

**Parent topic:** [Scanning in Epson Scan 2](#)

---

# Using Memory Cards with Your Product

Follow the instructions here to work with a memory card inserted into your product.

**Note:** Make sure your memory card and the files on it meet the specifications for your product.

[Inserting a Memory Card](#)

[Printing from a Memory Card](#)

[Transferring Photos on a Memory Card](#)

**Related references**

[Memory Card Specifications](#)

## Inserting a Memory Card

Insert a memory card into the memory card slot on your product as described here.

**Note:** Make sure your memory card and the files on it meet the specifications for your product.

1. Make sure the memory card and the files on it are compatible with your product before inserting the card.



2. Open the front cover.
3. Insert your memory card into the slot, making sure the card is oriented correctly.

**Note:** Do not force the card all the way into the slot. Insert it only until it meets resistance.

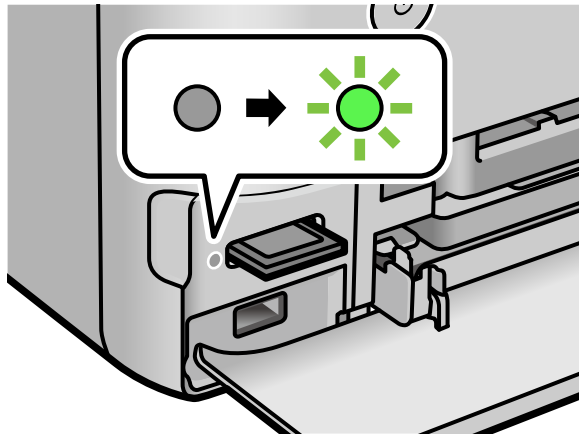
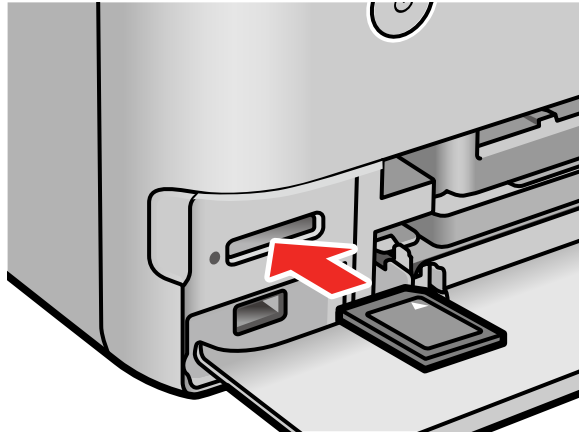

The memory card access light flashes and then stays lit.

**Caution:** Do not remove a memory card or turn off your product while the memory card access light is flashing or you may lose data from the memory card.

### Removing a Memory Card

**Parent topic:** [Using Memory Cards with Your Product](#)

#### Related references

[Memory Card Specifications](#)

## Removing a Memory Card

After you finish working with a memory card, check to make sure it is safe to remove it from your product.

**Caution:** Do not remove a memory card or turn off your product while the memory card access light is flashing or you may lose data from the memory card.

1. Make sure the memory card access light is not flashing.

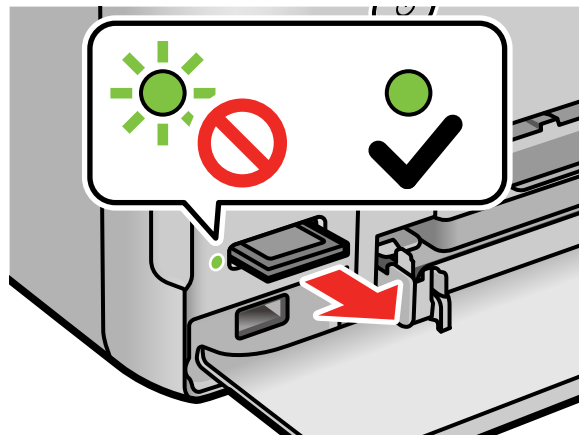

2. If your product is connected to your computer using a USB cable, do one of the following:
  - **Windows:** Open the **My Computer**, **Computer**, **Windows Explorer**, or **File Explorer** utility. Then right-click the name of your memory card (listed as a removable disk) and select **Eject**.
  - **Mac:** Drag the removable disk icon for your memory card from the desktop or computer window into the trash.

3. Push in the memory card, then pull it straight out of the slot.

**Parent topic:** [Inserting a Memory Card](#)

## Printing from a Memory Card

See these sections to print photos from a memory card inserted into your product.

[Viewing and Printing Photos](#)

[Printing Photo Layouts from a Memory Card with a Template](#)

[Printing ID Photos from a Memory Card](#)

[Creating and Printing a Greeting Card Template](#)

[Printing a Greeting Card from a Template](#)

**Parent topic:** [Using Memory Cards with Your Product](#)

## Viewing and Printing Photos

See these sections to view and print photos displayed on your product's LCD screen.

[Viewing and Printing Photos From the LCD Screen](#)

[Memory Card or External USB Device Print Settings](#)

**Parent topic:** [Printing from a Memory Card](#)

### Viewing and Printing Photos From the LCD Screen

You can select photos for printing as you view them on the LCD screen.

1. Load photo paper in your product.
2. Insert a memory card into your product's memory card slot.

**Note:** If **Auto Selection Mode** is turned on in the **Guide Functions** menu, select **to function index** when you see the information screen.

3. Select the  home icon, if necessary.

4. Select **Print Photos**.

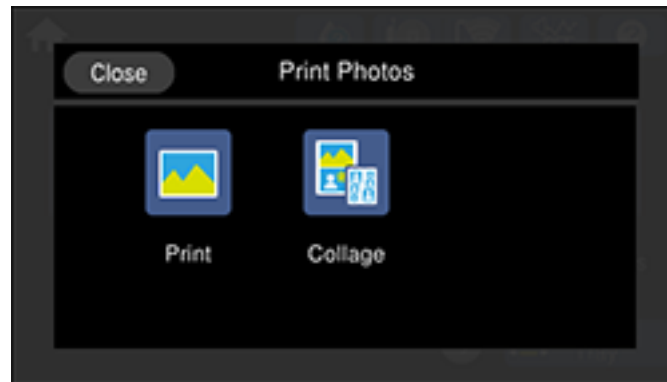

5. Select **Print** and select **OK**.

You see a screen like this:

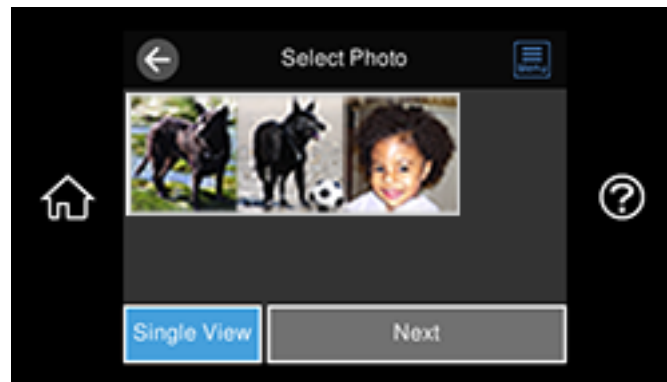

6. Do one of the following to select your photos:
  - Select the thumbnail images of the photos you want to print. Each photo you select has a number on it to indicate the number of prints you selected.

**Note:** If you want to print multiple copies of a photo, select **Single View** and press the **+** or **-** button to adjust the number of prints. Select **Tile View** to return to the thumbnail image view and select additional photos.

- To select all photos or a group of photos, select the  menu icon and select **Select All Photos**.

**Note:** The number of prints you select for each photo will be multiplied by the number of copies you select before printing.

7. If you need to edit a photo, select **Single View** during photo selection and select the left or right arrows to scroll to the photo you want to edit.

You see a screen like this:



- 1 Lets you zoom in and out of the photo.
- 2 Lets you apply filters, make color and red-eye corrections, and adjust cropping, rotation, brightness, contrast, sharpness, and saturation if necessary.

**Note:** Press the **Correction On** button to switch between **Correction Off** and **Correction On**. With **Correction On** selected, any corrections you make to a photo are displayed on the screen. With **Correction Off** selected, any corrections you make will only be applied to your printouts.

8. Select **Next** and select your paper and print settings as necessary.
9. Select **Copies** to change the number of copies as necessary.

**Note:** The number of copies you enter applies to each selected photo, including the number of prints already selected for each.

10. When you are ready to print, select the **Print** icon.

**Note:** To cancel printing, select **Cancel** and select **Close** to exit.

**Parent topic:** [Viewing and Printing Photos](#)

**Related references**

[Memory Card or External USB Device Print Settings](#)

**Related tasks**

[Inserting a Memory Card](#)

**Related topics**

[Loading Paper](#)

**Memory Card or External USB Device Print Settings**

Select the options you want to use when printing photos displayed on the LCD screen.

**Note:** Not all options or settings may be available, depending on other settings.

<b>Print settings</b>	<b>Available options</b>	<b>Description</b>
<b>Paper Setting</b>	<b>Cassette 1</b>	Prints onto paper loaded in Cassette 1 (upper cassette)
	<b>Cassette 2</b>	Prints onto paper loaded in Cassette 2 (lower cassette)
	<b>Cassette 1 &gt; 2</b>	Prints onto paper loaded in Cassette 1 and then onto paper loaded in Cassette 2 when the first cassette is empty (load the same size and type of paper in both cassettes when selecting this option)
	<b>Rear Paper Feed Slot</b>	Prints onto paper loaded in the rear paper feed slot
	<b>Rear Paper Feeder</b>	Prints onto paper loaded in the rear paper feeder
<b>Border Setting</b>	<b>Borderless</b>	Expands the image to the edge of the paper (slight cropping may occur)
	<b>With Border</b>	Leaves a small margin around the image

Print settings	Available options	Description
<b>Expansion</b>	<b>Standard</b>	Expands images correctly for most borderless prints
	<b>Medium</b>	Expands images slightly less for borderless prints
	<b>Minimum</b>	Expands images the least amount for borderless prints (you may see some white border)
<b>Fit Frame</b>	<b>On</b>	Automatically crops the photo to fit into the selected photo layout
	<b>Off</b>	Turns off automatic cropping
<b>Quality</b>	<b>Draft</b>	Provides lower quality for draft printing
	<b>Standard</b>	Provides good quality for most prints
	<b>High</b>	Provides higher quality for special prints
	<b>Best</b>	Provides the highest quality for important prints
	<b>Best(Ultra Glossy)</b>	Provides the highest quality for important prints when using glossy paper
<b>Date</b>	Various date formats	Prints the date the photo was taken on the photo in the format you select
	<b>Off</b>	No date information is printed
<b>Print Info on Photos</b>	<b>Camera Settings</b>	Prints some Exif camera settings, such as shutter speed, f-ratio, or ISO sensitivity (if available)
	<b>Camera Text</b>	Prints text that you added in your camera  <b>Note:</b> Available on borderless photos in these sizes: 4 × 6 inches (102 × 152 mm), 5 × 7 inches (127 × 178 mm), and 16:9 wide (4 × 7.1 inches [102 × 181 mm]).
	<b>Landmark</b>	Prints location information embedded in a photo by cameras with a built-in GPS feature  <b>Note:</b> Available on borderless photos in these sizes: 4 × 6 inches (102 × 152 mm), 5 × 7 inches (127 × 178 mm), and 16:9 wide (4 × 7.1 inches [102 × 181 mm]).
	<b>Off</b>	Turns off this setting

Print settings	Available options	Description
Clear All Settings	Yes	Restores all paper and print settings to their defaults.
	No	

Parent topic: [Viewing and Printing Photos](#)

#### Related tasks

[Viewing and Printing Photos From the LCD Screen](#)

## Printing Photo Layouts from a Memory Card with a Template

You can print one or more photos from a memory card in special layouts on various sizes of photo paper. You can have the product automatically place the photos in the layout or you can manually place them yourself.

1. Load photo paper in your product.
2. Insert a memory card into your product's memory card slot.

**Note:** If **Auto Selection Mode** is turned on in the **Guide Functions** menu, select **to function index** when you see the information screen.

3. Select the  home icon, if necessary.
4. Select **Print Photos**.

You see a screen like this:

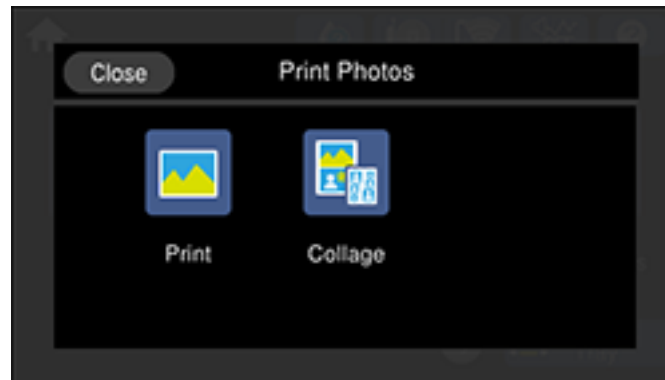



5. Select **Collage** and select **OK**.

You see a screen like this:

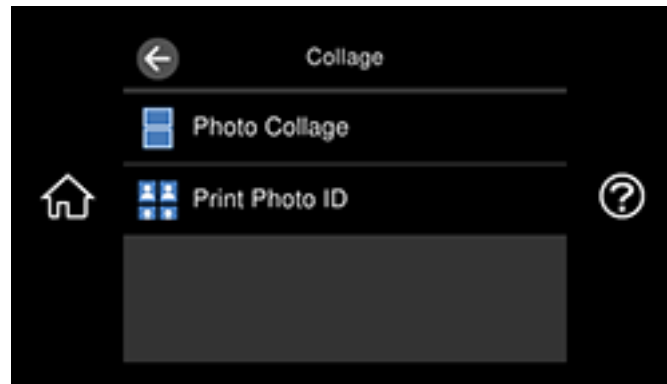

6. Select **Photo Collage** and select one of the displayed layout options.
7. Select a background type and design, if necessary.

**Note:** If you see a message telling you that loading photos is complete, select **OK**.

8. Do one of the following:
  - To select a specific position for a photo, select a layout position, select the photo you want to print, and select **Done**. Repeat these steps until all positions have a corresponding photo or all the photos you want to print have been selected. Select **Next**.
  - To layout the photos automatically, select **Automatic Layout**, select the photo(s) you want to print, and select **Next**. To repeat a photo in a layout, select **Single View** and press the left or right arrow button to scroll to the desired photo. Press the **+** or **-** button to adjust the number of prints for the photo.

**Note:** If you select more photos than will fit in the layout you selected, the layout automatically extends to multiple sheets. Select **Yes** on the confirmation screen to continue.

- Select the photo you want to print and select **Next**. To repeat a photo in a layout, select **Single View** and press the left or right arrow button to scroll to the desired photo. Press the **+** or **-** button to adjust the number of prints for the photo.

**Note:** If you select more photos than will fit in the layout you selected, the layout automatically extends to multiple sheets.

9. If you need to edit a photo, select **Single View** during photo selection and select the left or right arrow to scroll to the photo you want to edit.

You see a screen like this:



- 1 Lets you zoom in and out of the photo.
- 2 Lets you apply filters, make color and red-eye corrections, and adjust cropping, rotation, brightness, contrast, sharpness, and saturation if necessary.

**Note:** Press the **Correction On** button to switch between **Correction Off** and **Correction On**. With **Correction On** selected, any corrections you make to a photo are displayed on the screen. With **Correction Off** selected, any corrections you make will only be applied to your printouts.

10. Select your paper and print settings as necessary.
11. Select **Copies** to change the number of copies as necessary.
12. When you are ready to print, select the **Print** icon.

**Note:** To cancel printing, select **Cancel** and select **Close** to exit.

**Parent topic:** [Printing from a Memory Card](#)

#### **Related references**

[Memory Card or External USB Device Print Settings](#)

[Copying Options](#)

**Related tasks**

[Inserting a Memory Card](#)

**Related topics**

[Loading Paper](#)

## Printing ID Photos from a Memory Card

You can print ID photos from a memory card. Two copies of one photo are printed at different sizes onto this size photo paper: 4 × 6 inches (102 × 152 mm).

1. Load photo paper in your product.
2. Insert a memory card into your product's memory card slot.

**Note:** If **Auto Selection Mode** is turned on in the **Guide Functions** menu, select **to function index** when you see the information screen.

3. Select the  home icon, if necessary.
4. Select **Print Photos**.

You see a screen like this:

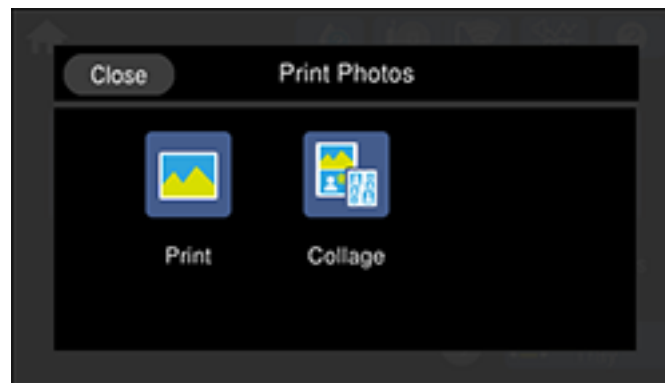

5. Select **Collage** and select **OK**.

You see a screen like this:

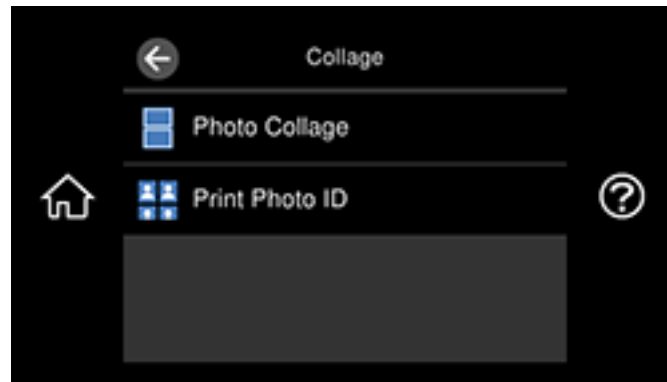

6. Select **Print Photo ID**.

**Note:** If you see a message telling you that loading photos is complete, select **OK**.

You see a screen like this:

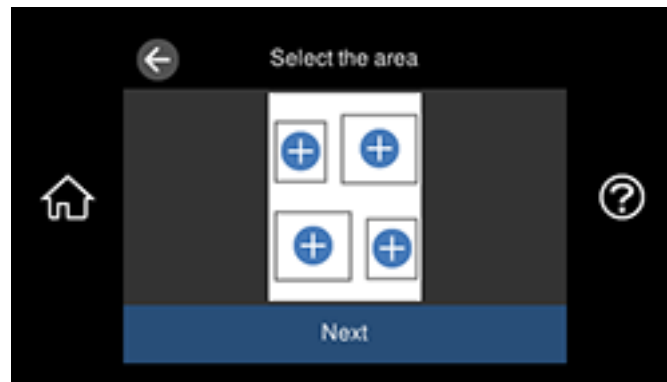

7. Select any layout position on the sheet.
8. Select the photo you want to print, then select **Done**.

9. If you need to edit a photo, select **Single View** during photo selection and select the left or right arrows to scroll to the photo you want to edit.

You see a screen like this:



- 1 Lets you zoom in and out of the photo.
- 2 Lets you apply filters, make color and red-eye corrections, and adjust cropping, rotation, brightness, contrast, sharpness, and saturation if necessary.

**Note:** Press the **Correction On** button again to switch between **Correction Off** and **Correction On**. With **Correction On** selected, any corrections you make to a photo are displayed on the screen. With **Correction Off** selected, any corrections you make will only be applied to your printouts.

10. Confirm the layout and select **Next**.
11. Select your paper and print settings as necessary.
12. Select **Copies** to change the number of copies as necessary.
13. When you are ready to print, select the **Print** icon.

**Note:** To cancel printing, select **Cancel** and select **Close** to exit.

**Parent topic:** [Printing from a Memory Card](#)

#### **Related references**

[Memory Card or External USB Device Print Settings](#)

### Related tasks

[Inserting a Memory Card](#)

### Related topics

[Loading Paper](#)

## Creating and Printing a Greeting Card Template

Before you start, make sure plain paper is loaded and your memory card is inserted.

1. Select the  home icon, if necessary.
2. Select **Various Prints**.

You see a screen like this:

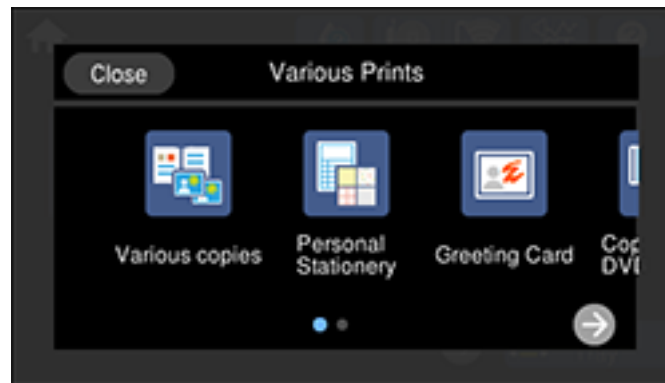

3. Select **Greeting Card** and select **OK**.

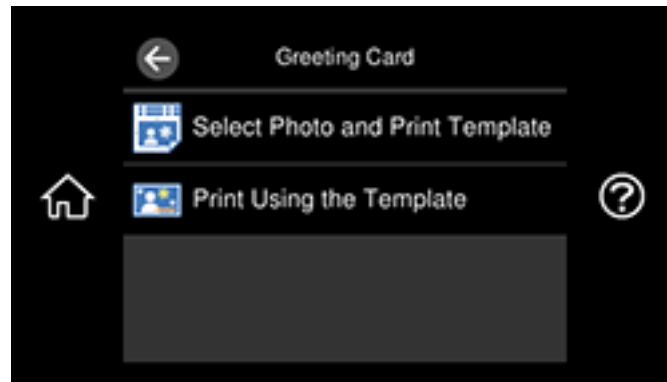

4. Select **Select Photo and Print Template** and select **OK**.
5. Do one of the following to select your photo:
  - Select the thumbnail image of the photo you want to print and select **Next**.
  - Select **Single View**, press the left or right arrow button to scroll to the photo you want to print, then select **Next**. You can also select **Tile View** to return to the thumbnail image view.
6. Select **Letter** as the **Paper Size** to print a template for three cards on one letter-size sheet or **4 x 6 in** to print a template for one card.
7. Confirm any changes, if necessary.
8. Select the **Paper Type** and **Layout** settings, as necessary.
9. Select **Select Photo and Print Template**.
10. When you are ready to print, select the **Print** icon.

**Note:** To cancel printing, select **Cancel** and select **Close** to exit.

11. When printing is finished, select **Close**.

**Parent topic:** [Printing from a Memory Card](#)

#### **Related references**

[Memory Card or External USB Device Print Settings](#)

### Related tasks

[Inserting a Memory Card](#)

[Printing a Greeting Card from a Template](#)

### Related topics

[Loading Paper](#)

## Printing a Greeting Card from a Template

After your greeting card template is printed, you fill it out to create your card and add your message.

1. Use a dark pen or pencil to fill in the circles and select the Text Style and Text Effects.

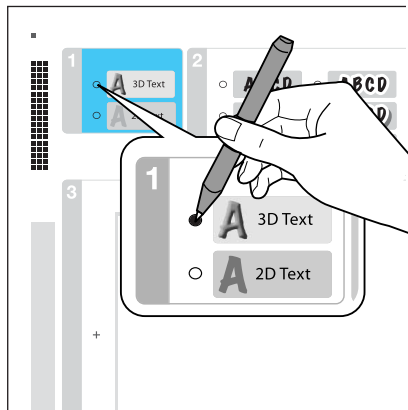

2. Add your greeting card message within the box. You can write it in by hand, print a message and paste it into the box, or draw a picture.

**Note:** When adding text, place it in the direction that your photo faces.

3. Load photo paper in Cassette 2 (lower) for this size: Letter (8.5 × 11 inches [216 × 279 mm]), or in Cassette 1 (upper) for this size: 4 × 6 inches (102 × 152 mm).
4. Select **Print Using the Template**.

**Note:** If you do not see **Print Using the Template**, select the  home icon and select **Various Prints > Greeting Card > OK > Print Using the Template**. Then select **OK** twice.



5. Select **Edit** to adjust image settings, if necessary.
6. Open the document cover and place the template facedown on the scanner glass against the triangle in the lower right corner.

**Note:** Select **How To** to view instructions on the LCD screen.

7. Close the document cover.
8. Select **Copies** and use the numeric keypad to select the number of copies (up to 99).
9. When you are ready to print, select the **Print** icon.

**Note:** To cancel printing, select **Cancel** and select **Close** to exit.

When you finish printing, cut your greeting cards apart, if necessary.

**Parent topic:** [Printing from a Memory Card](#)

**Related topics**

[Loading Paper](#)

## Transferring Photos on a Memory Card

You can transfer photos to and from a memory card inserted into a memory card slot on your product.

[Setting Up File Sharing for Photo Transfers from Your Computer](#)

[Transferring Photos from a Memory Card to Your Computer](#)

**Parent topic:** [Using Memory Cards with Your Product](#)

## Setting Up File Sharing for Photo Transfers from Your Computer

Before you transfer photos from a computer to a memory card inserted into a memory card slot on your product, you may need to set up your product's file sharing settings.

**Caution:** Remove the memory card before you change this setting or you may lose data from the memory card. Do not remove a memory card or turn off your product while the memory card access light is flashing or you may lose data from the memory card.

1. Remove any memory cards from the product.
2. Select the  home icon, if necessary.
3. Select **Settings > File Sharing Setup**.

You see a screen like this:

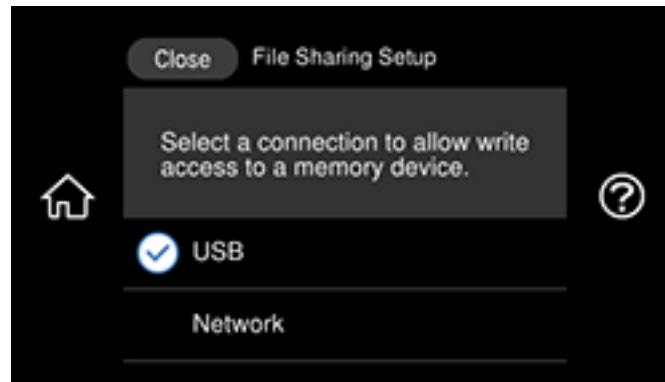

4. Select your connection type.
5. Select the  home icon to exit.

**Parent topic:** [Transferring Photos on a Memory Card](#)

#### **Related tasks**

[Removing a Memory Card](#)

## **Transferring Photos from a Memory Card to Your Computer**

You can transfer photos to and from a memory card inserted into a memory card slot on your product and a computer connected to your product.

**Note:** Do not transfer photos to and from a memory card while you are printing from the memory card.

1. Make sure your product is connected to a computer.
2. Insert a memory card into a memory card slot on your product.
3. Do one of the following to access your memory card files from your computer:
  - **Windows:** Open the **Computer**, **My Computer**, **Windows Explorer**, or **File Explorer** utility, then select the removable disk icon.
  - **Mac with a USB connection:** Look for the removable disk icon on your desktop or computer window, then select it.

- **Mac with a network connection:** Select the hard drive icon on your desktop or computer window, select your product in the **SHARED** section of the sidebar (you may need to widen the sidebar to see the name), then select the **MEMORYCARD** icon.
4. Select the folder that contains your photos.
  5. Drag the photos you want to transfer to the desired folder on your computer or on your memory card.

**Note:** Your product's LCD screen does not update to display new photos transferred to the memory card. Wait until the memory card access light stops flashing, then remove and insert the memory card to update the photos displayed.

**Parent topic:** [Transferring Photos on a Memory Card](#)

**Related tasks**

[Inserting a Memory Card](#)

---

# Using an External Device with Your Product

Follow the instructions in these sections to use your product with an external device, such as a camera, USB flash drive, or other USB device.

[Printing from a Camera](#)

[Viewing or Printing from a USB Flash Drive or External Device](#)

## Printing from a Camera

If you have a digital camera that supports PictBridge printing, you can print your photos directly from the camera. Check your camera manual to see if it is compatible.

**Note:** Your photos must be in JPG format and sized from 80 × 80 to 10200 × 10200 pixels. Epson cannot guarantee the compatibility of your camera. Some combinations of paper type, size, and layout may not be supported, depending on your camera and the product settings.

[Selecting Print and Photo Adjustment Settings](#)

[Connecting and Printing from a Camera](#)

[Printing from a Camera Wirelessly](#)

**Parent topic:** [Using an External Device with Your Product](#)

## Selecting Print and Photo Adjustment Settings

Before printing from your camera, you can make image adjustments and select the print settings for your photos. Image adjustments affect only the printed copy of the photo, not the original file.

1. Select the  home icon, if necessary.
2. Select **Settings** > **Camera Print Settings**.

You see a screen like this:

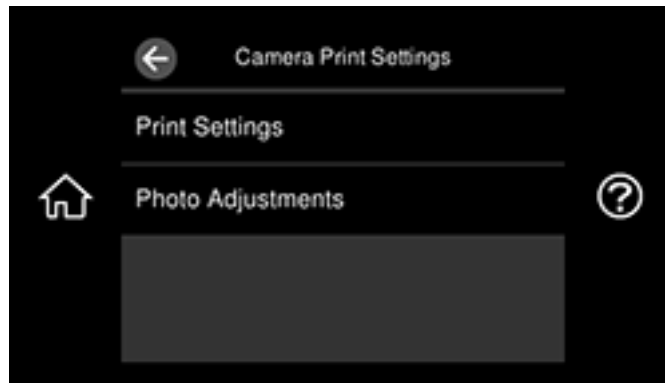

3. Select **Print Settings**.

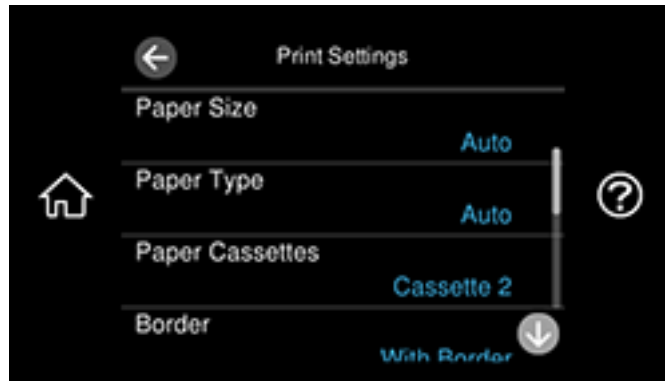

4. Select the paper and print settings you want to use.
5. When you are done, select .

6. Select **Photo Adjustments**.



7. Select the photo adjustments you want to use.

8. Select the  home icon to exit.

After you select settings, you are ready to connect your camera and print your photos.

[Print Settings - Camera](#)

[Photo Adjustments - Camera](#)

**Parent topic:** [Printing from a Camera](#)

**Related tasks**

[Connecting and Printing from a Camera](#)

### **Print Settings - Camera**

Select these print settings options when printing photos from your camera.

<b>Print settings</b>	<b>Available options</b>	<b>Description</b>
<b>Paper Setting</b>	<b>Cassette 1</b>	Prints onto paper loaded in Cassette 1 (upper cassette)
	<b>Cassette 2</b>	Prints onto paper loaded in Cassette 2 (lower cassette)
	<b>Cassette 1&gt; 2</b>	Prints onto paper loaded in Cassette 1 and then onto paper loaded in Cassette 2 when the first cassette is empty (load the same size and type of paper in both cassettes when selecting this option)
	<b>Rear Paper Feed Slot</b>	Prints onto paper loaded in the rear paper feed slot
	<b>Rear Paper Feeder</b>	Prints onto paper loaded in the rear paper feeder
<b>Border</b>	<b>Borderless</b>	Expands the image to the edge of the paper (slight cropping may occur)
	<b>With Border</b>	Leaves a small margin around the image
<b>Expansion</b>	<b>Standard</b>	Expands images correctly for most borderless prints
	<b>Medium</b>	Expands images slightly less for borderless prints
	<b>Minimum</b>	Expands images the least for borderless prints (you may see some white border)
<b>Fit Frame</b>	<b>On</b>	Automatically crops the photo to fit into the selected photo layout
	<b>Off</b>	Turns off automatic cropping
<b>Quality</b>	<b>Draft</b>	Provides lower quality for draft printing
	<b>Standard</b>	Provides good quality for most prints
	<b>High</b>	Provides higher quality for special prints
	<b>Best</b>	Provides the highest quality for important prints
	<b>Best(Ultra Glossy)</b>	Provides the highest quality for important prints when using glossy paper
<b>Date</b>	<b>Off</b>	Does not print the date on which the photo was taken
	<b>On</b>	Prints the date on which the photo was taken

Print settings	Available options	Description
<b>Print Info on Photos</b>	<b>Camera Settings</b>	Prints some Exif camera settings, such as shutter speed, f-ratio, or ISO sensitivity (if available)
	<b>Camera Text</b>	Prints text that you added in your camera Available on borderless photos in these sizes: 4 × 6 inches (102 × 152 mm), 5 × 7 inches (127 × 178 mm), and 16:9 wide (4 × 7.1 inches [102 × 181 mm])
	<b>Landmark</b>	Prints location information embedded in a photo by cameras that have a built-in GPS feature Available on borderless photos in these sizes: 4 × 6 inches (102 × 152 mm), 5 × 7 inches (127 × 178 mm), and 16:9 wide (4 × 7.1 inches [102 × 181 mm])
	<b>Off</b>	Prints no information on photos
<b>Clear All Settings</b>	<b>Yes</b>	Restore all paper and print settings to their defaults
	<b>No</b>	

Parent topic: [Selecting Print and Photo Adjustment Settings](#)

### Photo Adjustments - Camera

Select these photo adjustment options when printing photos from your camera. The modifications affect only the printed copy of the photo, not the original file.

Photo Adjustments settings	Available options	Description
<b>Fix Photo</b>	<b>Auto</b>	Optimizes the <b>Fix Photo</b> adjustments for specific types of photos; select the option that best matches your photo content
	<b>People</b>	
	<b>Landscape</b>	
	<b>Night Scene</b>	
	<b>Enhance Off</b>	Turns off the enhancement feature



Photo Adjustments settings	Available options	Description
<b>Fix Red-Eye</b>	<b>Off - Current</b>	Does not automatically fix the red-eye effect in photos
	<b>On - Current</b>	Automatically fixes the red-eye effect in photos
<b>Filter</b>	<b>Off</b>	Turns off the filter setting
	<b>Sepia</b>	Applies a sepia tone filter to the viewed or printed photo
	<b>B&amp;W</b>	Applies a black-and-white filter to the viewed or printed photo
<b>Brightness</b>	Various settings	Adjust individual qualities in your photo
<b>Contrast</b>		
<b>Sharpness</b>		
<b>Saturation</b>		
<b>Clear All Settings</b>	<b>Yes</b>	Restores all adjustment settings to their defaults.
	<b>No</b>	

**Note: Fix Photo** uses a sophisticated face recognition technology to optimize photos that include faces. For this to work, both eyes and the nose must be visible in the subject's face. If your photo includes a face with an intentional color cast, such as a statue, you may want to turn off **Fix Photo** to retain the special color effects.

Parent topic: [Selecting Print and Photo Adjustment Settings](#)

## Connecting and Printing from a Camera

Before you connect your camera, make sure the product is turned on but not printing.

1. Remove any memory cards or external USB devices from the product.
2. Load the paper you want to print on.
3. Turn on your camera.

4. Connect the USB cable that came with your camera to the  USB port on the front of your product and to your camera.

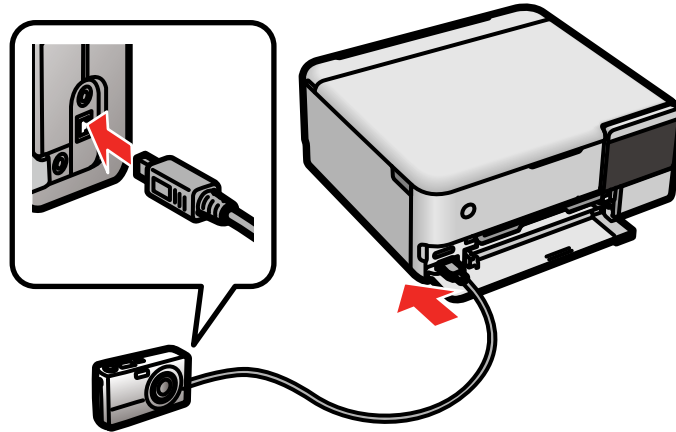

**Note:** Use a USB cable that is no longer than 6.5 ft (2 m).

5. Follow the instructions that came with your camera to select and print your photos. When you finish printing, turn off your camera and disconnect it from the product.

**Parent topic:** [Printing from a Camera](#)

**Related tasks**

[Connecting and Using a USB Flash Drive or External Device](#)

[Removing a Memory Card](#)

**Related topics**

[Loading Paper](#)

## Printing from a Camera Wirelessly

You can print photos from a digital camera using a wireless connection. Make sure your digital camera can connect to a network and is PictBridge compatible (DPS over IP).

**Note:** You cannot use other product functions or print from other devices while using PictBridge.

1. Remove any memory cards from the product.

2. Load the paper you want to print on.
3. Turn on your camera.
4. Set up the camera's wireless network connection. See the documentation that came with your camera for details.

**Note:** Connect the camera to the same network that your product uses. You can print a Network Status sheet to view your product's network settings.

5. Follow the instructions that came with your camera to select and print your photos.

When you finish printing, turn off your camera and disconnect it from the network.

**Parent topic:** [Printing from a Camera](#)

**Related tasks**

[Connecting and Printing from a Camera](#)

[Removing a Memory Card](#)

[Printing a Network Status Sheet](#)

**Related topics**

[Loading Paper](#)

## Viewing or Printing from a USB Flash Drive or External Device

You can view and print photos from a USB flash drive or other external USB device, such as an external hard drive or CD/DVD burner.

**Note:** Make sure the files on your device are compatible with the product.

[Connecting and Using a USB Flash Drive or External Device](#)

**Parent topic:** [Using an External Device with Your Product](#)

**Related references**

[External Device Specifications](#)

[Supported Data Specifications](#)

## Connecting and Using a USB Flash Drive or External Device

Before you connect your flash drive or external device, make sure the product is turned on but not printing.

**Note:** Epson cannot guarantee the compatibility of your device.

1. Remove any memory cards from the product.

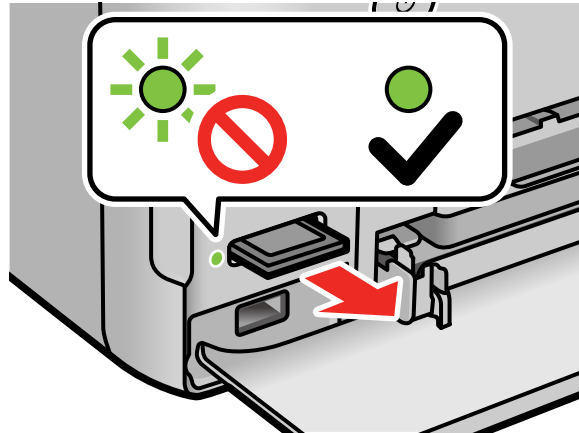

**Caution:** Do not remove a memory card or turn off your product while the memory card access light is flashing or you may lose data from the memory card.

2. Load the paper you want to print on.
3. Insert your USB flash drive or the USB cable that came with your device into the  USB port on the front of your product.

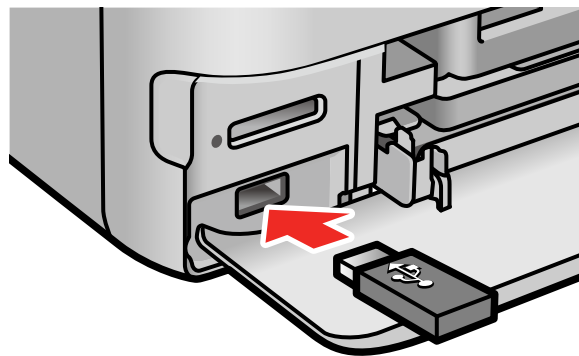

4. Insert storage media (such as a CD) into your drive, if necessary.
5. Select the photos to print from the LCD screen.

When you finish printing, make sure the access light on the device is not flashing, then remove or disconnect it from the product.

**Caution:** Do not remove the USB device or turn off the product when the access light is flashing, or you may lose photos on the device.

**Parent topic:** [Viewing or Printing from a USB Flash Drive or External Device](#)

**Related tasks**

[Connecting and Printing from a Camera](#)

[Removing a Memory Card](#)

[Viewing and Printing Photos From the LCD Screen](#)

**Related topics**

[Loading Paper](#)

---

# Printing Personalized Projects

You can print a variety of personalized projects, including some with a photo background.

[Printing a Personalized Project](#)

## Printing a Personalized Project

You can print patterned paper, calendars, lined paper, graph paper, music sheets, stationery with a photo background, or coloring book pages. You can also print images from a memory card onto CD/DVDs and jewel case inserts.

1. Load paper into the product.
2. Select the  home icon, if necessary.
3. Select **Various Prints**.

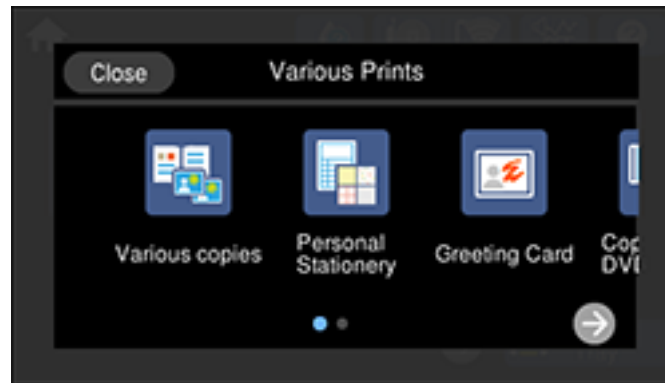

4. Select one of the following:
  - **Personal Stationery** lets you print a variety of project types on paper:
    - **Design Paper** lets you print patterned paper from preset designs.
    - **Calendar** lets you create and print a weekly or monthly calendar page using photos stored on a memory device.
    - **Schedule** lets you create and print a monthly, weekly, or daily schedule page.
    - **Ruled Paper** lets you print music sheets, wide-rule or narrow-rule notebook paper, and graph paper.

- **Writing Papers** lets you print lined or unlined note paper with one of your own photos in the background.
  - **Copy to CD/DVD** lets you print a variety of projects onto a CD/DVD or jewel case insert:
    - **Print on CD/DVD** lets you print one or more photos from a memory card or external USB device directly onto an ink jet-printable CD, DVD, or Blu-ray Disc. If you want, you can first print a test design on plain paper.
    - **Print on Jewel Case** lets you print a photo from a memory card or external USB device onto a CD/DVD jewel case insert. Your product automatically resizes the photo to fit, but you can also print multiple thumbnail images formatted to fit on a jewel case insert. After the insert is printed, you can cut and fold it to fit.
  - **Coloring Books** lets you create a coloring book page from a photo on your memory card or external USB device, or from a photo or drawing placed on the scanner glass.
5. Follow the instructions on the screen to select the options for your project.
  6. When you are ready to print, select the **Print** icon.

**Note:** To cancel printing, select **Cancel** and select **Close** to exit.

**Parent topic:** [Printing Personalized Projects](#)

**Related references**

[Memory Card or External USB Device Print Settings](#)

**Related tasks**

[Connecting and Using a USB Flash Drive or External Device](#)

[Inserting a Memory Card](#)

**Related topics**

[Printing on CDs/DVDs](#)

[Loading Paper](#)

[Placing Originals on the Product](#)

---

## Printing on CDs/DVDs

Follow the instructions in this section to print a design onto ink jet-printable CDs or DVDs to create a custom label.

[CD/DVD Printing Features](#)

[Loading a CD/DVD](#)

[Copying onto a CD/DVD](#)

### CD/DVD Printing Features

You can use any of the following features to print custom CD/DVD/Blu-ray Disc labels and accessories:

- Copy an existing label onto a new CD/DVD/Blu-ray Disc
- Use your product's control panel to print photos from a memory card onto a CD/DVD/Blu-ray Disc
- Print text and images from your computer using the Epson Photo+ software

You can also use your product's control panel to create a jewel case insert with photos from a memory card.

**Parent topic:** [Printing on CDs/DVDs](#)

#### Related concepts

[Printing with Epson Photo+](#)

#### Related tasks

[Printing a Personalized Project](#)

[Copying onto a CD/DVD](#)

### Loading a CD/DVD

You can print on any compatible, ink jet-printable CDs or DVDs, including Blu-ray Discs.

**Caution:** Do not insert the CD/DVD tray while the product is printing, copying, or performing other operations. Otherwise, your product may be damaged or the surface of the CD/DVD may become dirty or scratched.

**Note:** If you are using discs where the printable area extends to within 0.16 inch (4 mm) of the center hole, you may need to adjust the inner diameter setting using the control panel or Epson Photo+ software.



1. Burn your files, music, or video onto your disc before printing on it.
2. Select the  home icon, if necessary.
3. Select **Output Tray** to close the output tray, if necessary.
4. Remove the CD/DVD tray from beneath Cassette 2 (lower).

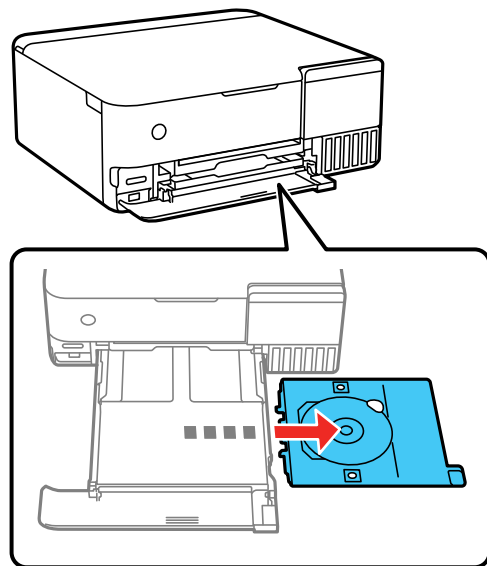

5. When prompted to load a CD/DVD, you can select the option to view an animation of the loading procedure. Follow the on-screen instructions to load the disc into the CD/DVD tray.

**Note:** Be sure to fully seat the CD or DVD or it may fall out when the tray is turned over.

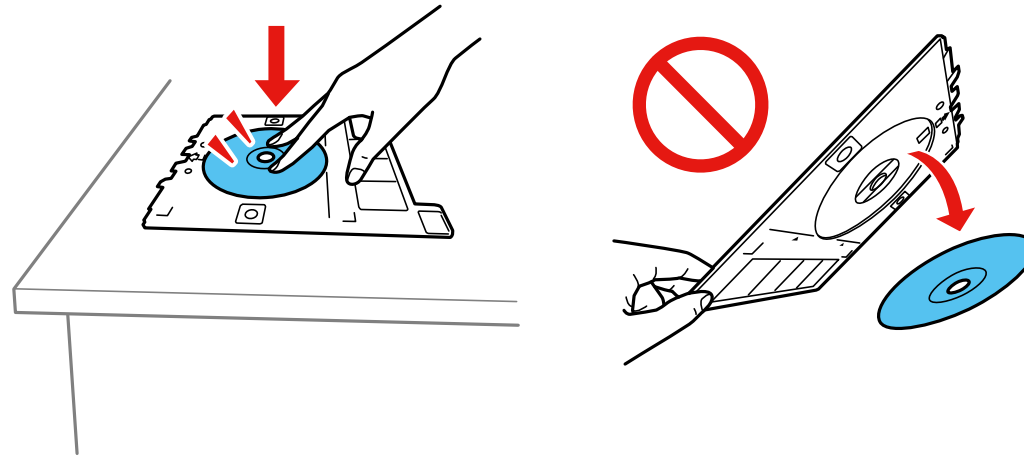

**Caution:** Do not turn off the product with a CD or DVD loaded in it. Always remove the disc first.

After your CD or DVD is printed, the tray extends automatically. Remove it from your product, remove the CD or DVD from the tray, and select **Printing Complete** on the LCD screen. Make sure you insert the CD/DVD tray into the storage slot beneath Cassette 2 when you're finished.

**Caution:** Always remove the CD/DVD tray after printing. If you turn the product off and on again or perform a head cleaning without removing the tray, the print head may contact the CD/DVD tray and cause the product to malfunction. After printing, handle the CD or DVD carefully. You may need to wait up to 24 hours for the ink to dry fully before inserting it in a drive, depending on the type of disc you used. Keep printed discs away from moisture and direct sunlight.

Parent topic: [Printing on CDs/DVDs](#)

## Copying onto a CD/DVD

You can copy a printed photo or CD/DVD label directly onto an ink jet-printable CD or DVD. If you want, you can first print a test design on plain paper.

1. Load the CD, DVD, or plain paper you want to print on.
2. Select the  home icon, if necessary.
3. Select **Various Prints**.

You see a screen like this:

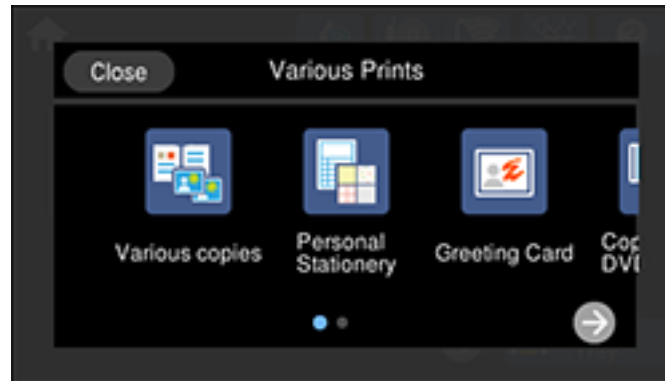

4. Select **Copy to CD/DVD** and select **OK**.
5. Select **Copy to CD/DVD** and follow the instructions on the LCD screen to do one of the following:
  - Place your photo facedown on the scanner glass.
  - Place your CD or DVD facedown in the center of the scanner glass.

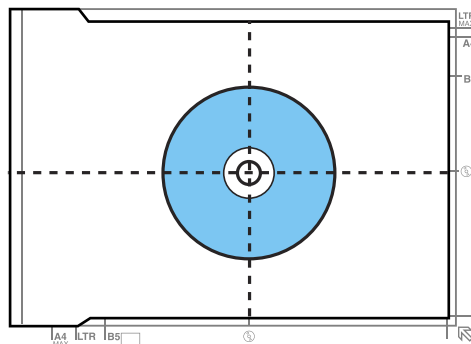

6. If necessary, adjust the inner and outer diameter of your CD as shown on the screen, and select **Select Type**.

You see a screen like this:



7. Do one of the following:
  - To print on a CD or DVD, select **Print on CD/DVD**. Select **How To** to view CD loading instructions or select **Installed** if the CD is already loaded.
  - To print a test print on plain paper, select **Test Print on Letter/A4**. Select any copy settings as necessary.
8. When you are ready to print, select the **Copy** icon.

**Note:** To cancel printing, select **Cancel** and select **Close** to exit.

**Parent topic:** [Printing on CDs/DVDs](#)

**Related tasks**

[Loading a CD/DVD](#)

**Related topics**

[Placing Originals on the Product](#)

---

# Refilling Ink and Replacing the Maintenance Box

Periodically check the ink tanks to see if they need to be refilled.

Before checking the ink level or refilling an ink tank as described here, be sure to read the ink safety precautions.

**Caution:** Visually check the ink levels in the product's ink tanks to confirm the actual ink levels. Continued use of the product when the ink is expended could damage the product.

[Ink Safety Precautions](#)

[Checking the Ink and Maintenance Box Levels](#)

[Purchase Epson Ink and Maintenance Box](#)

[Refilling the Ink Tanks](#)

[Maintenance Box Replacement](#)

**Related concepts**

[Print Head Maintenance](#)

## Ink Safety Precautions

**Note:** Epson strongly recommends the use of genuine ink to ensure optimal print quality and performance.

**Note:** The product has a low ink alert system. The accuracy of this system depends on the user refilling the ink tanks correctly. The product cannot directly measure the ink levels in the tanks; instead it estimates the amount of ink remaining by internally monitoring ink usage. The low ink alert system may generate inaccurate messages if the ink tanks are not refilled according to these instructions.

As a precaution, perform regular visual inspections of the ink tanks to ensure ink levels do not fall below the lower line. Continued use of the product when the ink level is below the lower line on the tank could damage the product.

### Ink Handling Precautions

- Keep ink bottles and the ink tanks out of the reach of children. Do not allow children to drink from or handle the ink bottles and bottle caps.
- Do not tilt or shake an ink bottle after opening it; otherwise, ink may leak.

- If ink gets on your skin, wash it thoroughly with soap and water. If ink gets into your eyes, flush them immediately with water. If discomfort or problems persist, see a doctor immediately. If ink gets into your mouth, spit it out and see a doctor right away.
- Do not shake or squeeze the ink bottles.
- If ink spills, wipe it up immediately. To prevent the ink from spreading, blot the spill with a dry cloth, then wipe it with a damp cloth. The ink will be hard to remove once it has dried.

### **Ink Refilling Precautions**

- Use ink bottles with the correct part number for this product.
- The use of non-Epson ink may cause damage that is not covered by Epson's warranty, and under certain circumstances, may cause erratic product behavior.
- This product requires careful handling of ink. Ink may splatter when the ink tanks are filled or refilled with ink. If ink gets on your clothes or belongings, it may not come off.
- Do not open the ink bottle package until you are ready to fill an ink tank. Ink bottles are vacuum packed to maintain reliability. If you leave an ink bottle unpacked for a long time before using it, print quality may be affected.
- If the ink level is below the lower line on an ink tank, refill the ink. Continued use of the product when the ink level is below the lower line on an ink tank could damage the product.
- Visually check the ink levels in the product's ink tanks to confirm the actual ink levels. Continued use of the product when the ink is expended could damage the product.
- For optimum printing results, refill the ink tanks to the upper line at least once a year.
- After bringing an ink bottle inside from a cold storage site, allow it to warm up at room temperature for at least three hours before using it.
- Use the ink bottle before the date printed on the package.
- After opening an ink bottle, Epson recommends using it as soon as possible.
- Store ink bottles in a cool, dark place. Keep them out of direct sunlight.
- Store the ink bottles in the same environment as the product. When storing or transporting an opened ink bottle, do not tilt the bottle and do not subject it to impacts or temperature changes. Otherwise, ink may leak even if the cap on the ink bottle is tightened securely. Be sure to keep the ink bottle upright when tightening the cap, and take measures to prevent ink from leaking when you transport the bottle.

### **Ink Bottle and Ink Tank Information**

- To maintain optimum print head performance, some ink is consumed from all ink tanks during printing and when performing maintenance operations, such as cleaning the print head. Ink may also be consumed when the product is turned on.
- Part of the ink from the included bottles is used for printer setup. You will notice ink levels in the tank decrease during charging. This decrease is normal and does not affect the stated in-box yields.
- Quoted ink yields may vary depending on the images you are printing, the paper type you are using, how often you print, and environmental conditions such as temperature.
- The ink bottles may contain recycled materials, but this does not affect product function or performance.
- When printing in monochrome or grayscale, color ink may be used instead of black ink, depending on the paper type or print quality settings. This is because a mixture of color inks is used to create black.
- A reserve amount of ink remains in the tank when your product indicates that a refill is necessary.

**Parent topic:** [Refilling Ink and Replacing the Maintenance Box](#)

## **Checking the Ink and Maintenance Box Levels**

Your product and software will let you know when to refill an ink tank or replace the maintenance box.

[Checking the Ink Levels on Your Product](#)

[Checking Maintenance Box Status on the LCD Screen](#)

[Checking Ink and Maintenance Box Levels - Windows](#)

[Checking Ink and Maintenance Box Levels - Mac](#)

[Disabling Special Offers with Windows](#)

**Parent topic:** [Refilling Ink and Replacing the Maintenance Box](#)

## Checking the Ink Levels on Your Product

To confirm the actual ink remaining, visually check the ink levels in the product's ink tanks. Make sure the ink levels are above the lower line on the ink tanks. If any of the ink tanks are below the lower line, fill them to the upper line on the ink tank.

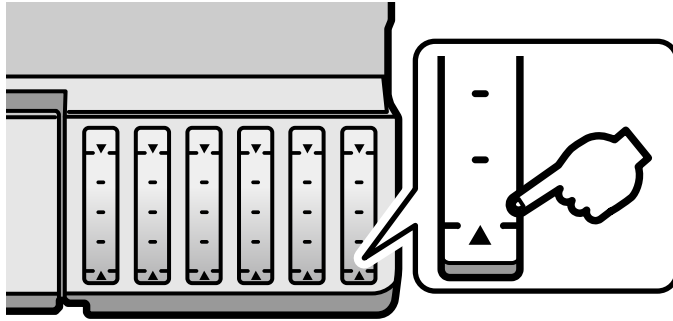

**Note:** The product has a low ink alert system. The accuracy of this system depends on the user refilling the ink tanks correctly. The product cannot directly measure the ink levels in the tanks; instead it estimates the amount of ink remaining by internally monitoring ink usage. The low ink alert system may generate inaccurate messages if the ink tanks are not refilled according to these instructions.

As a precaution, perform regular visual inspections of the ink tanks to ensure ink levels do not fall below the lower line. Continued use of the product when the ink level is below the lower line on the tank could damage the product.

**Parent topic:** [Checking the Ink and Maintenance Box Levels](#)

## Checking Maintenance Box Status on the LCD Screen

You can check the status of your maintenance box using your product's LCD screen.

1. Select the  home icon, if necessary.



2. Select the  icon and select **Proceed**.

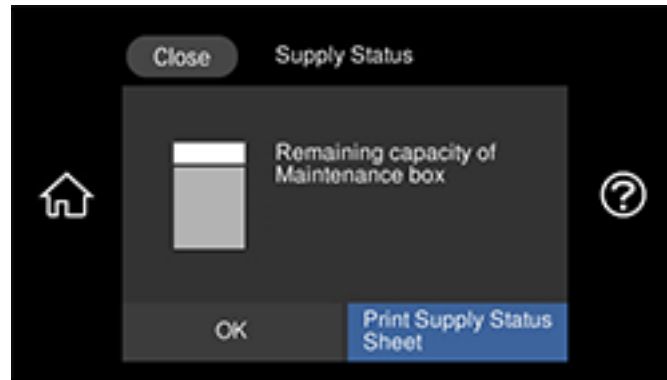

You see the remaining ink capacity of the maintenance box.

3. Select **OK** to exit the screen.



**Parent topic:** [Checking the Ink and Maintenance Box Levels](#)

**Related concepts**

[Maintenance Box Replacement](#)

## Checking Ink and Maintenance Box Levels - Windows

A low ink reminder appears if you try to print when ink is low, and you can check your ink levels at any time using a utility on your Windows computer.

1. To check your ink and maintenance box levels, access the Windows Desktop and double-click the  icon for your product in the right side of the Windows taskbar, or click the up arrow and double-click .

You see a window like this:

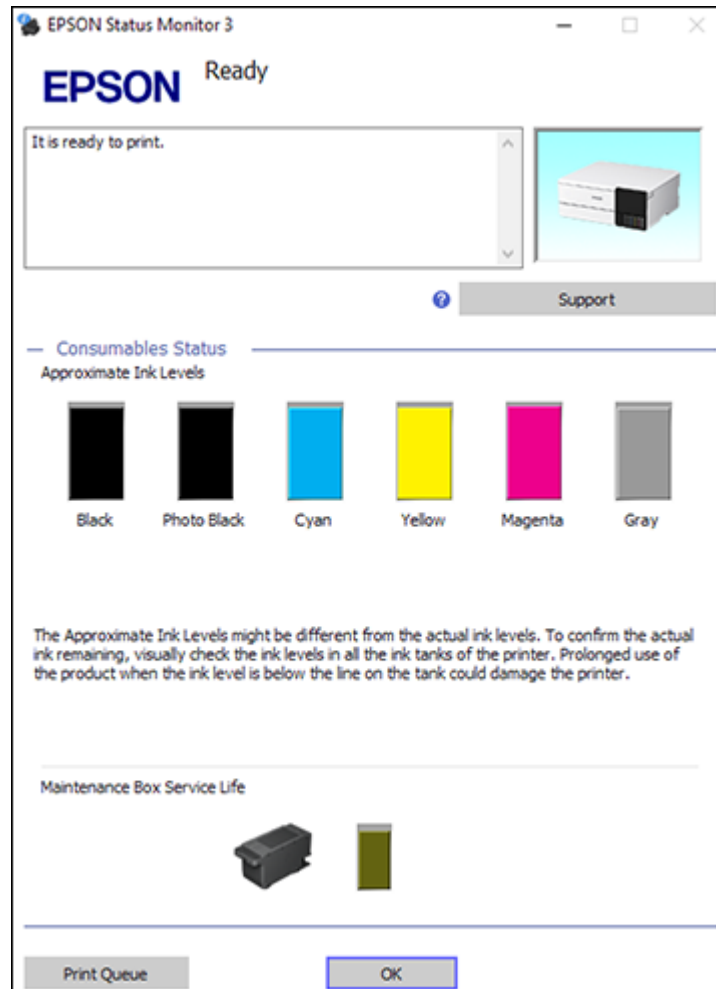

2. Refill any ink tank or replace the maintenance box as needed.

**Parent topic:** [Checking the Ink and Maintenance Box Levels](#)

**Related concepts**

[Maintenance Box Replacement](#)

## Related tasks

[Refilling the Ink Tanks](#)

## Checking Ink and Maintenance Box Levels - Mac

You can check your ink levels using a utility on your Mac.

1. In the Apple menu or the Dock, select **System Preferences**. Select **Print & Fax**, **Print & Scan**, or **Printers & Scanners**, select your product, and select **Options & Supplies**. Select **Utility** and select **Open Printer Utility**.
2. Select **EPSON Status Monitor**.

You see a window like this:



3. Refill any ink tank or replace the maintenance box as needed.

**Note:** To update or refresh the displayed ink levels, click **Update**.

**Parent topic:** [Checking the Ink and Maintenance Box Levels](#)

**Related concepts**

[Maintenance Box Replacement](#)



**Related tasks**

[Refilling the Ink Tanks](#)

## Disabling Special Offers with Windows

You can disable special offers messages from Epson using a utility on your Windows computer.

**Note:** You may see the Epson Special Offers screen every time you print (if your computer is connected to the Internet). Select **Do not display this message again** and click **Decline** to disable online offers. Promotional offers are not valid in Latin America.

1. Access the Windows Desktop and right-click the  icon for your product in the right side of the Windows taskbar, or click the up arrow and right-click . Select **Monitoring Preferences**.

You see this window:

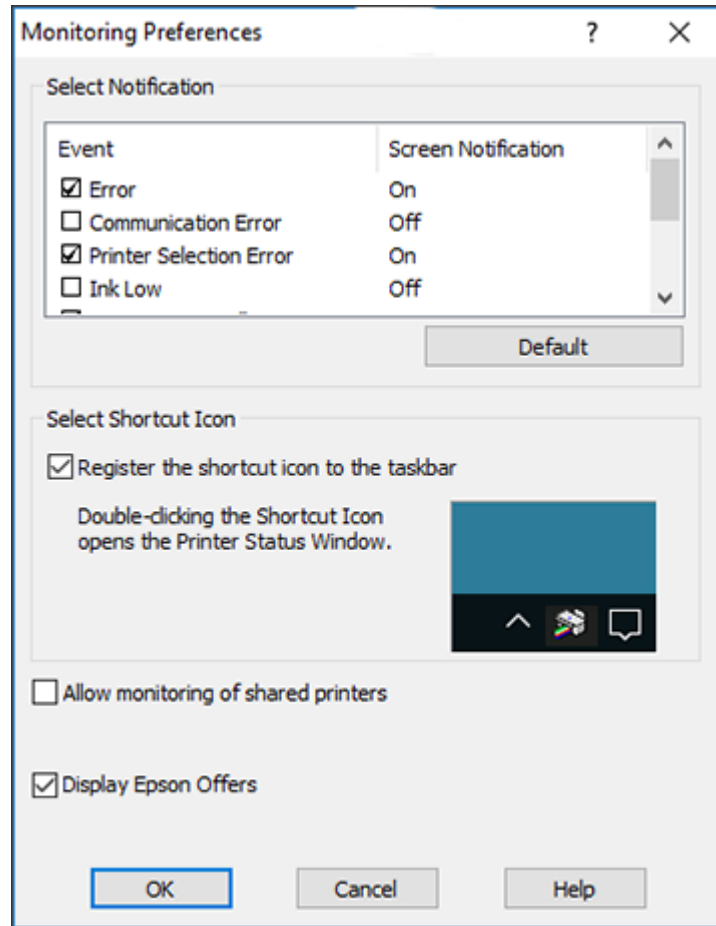

2. To disable promotional offers, deselect the **Display Epson Offers** checkbox.

Parent topic: [Checking the Ink and Maintenance Box Levels](#)

## Purchase Epson Ink and Maintenance Box

You can purchase genuine Epson ink, maintenance boxes, and paper from an Epson authorized reseller. To find the nearest reseller, visit [latin.epson.com](http://latin.epson.com) or call your nearest Epson sales office.

**Note:** This product is designed to work with genuine Epson inks. Non-Epson ink or any other ink not specified for this printer could cause damage not covered by Epson's warranties.

The ink bottles that are used for initial product setup have a lower yield due to the ink charging process. This process is carried out the first time you turn on the printer and guarantees better performance. Yields vary considerably based on print jobs, print settings, paper type, frequency of use, and temperature. Do not load paper before refilling the ink tanks.

Check the ink levels in your product frequently, and refill the ink tanks if necessary.

[Ink Bottle and Maintenance Box Part Numbers](#)

**Parent topic:** [Refilling Ink and Replacing the Maintenance Box](#)

## Ink Bottle and Maintenance Box Part Numbers

Use these part numbers when you order or purchase new ink bottles or a new maintenance box. Use the ink by the date printed on the package.

Ink color	Part number
Photo Black	555
Black	554
Cyan	555
Magenta	555
Yellow	555
Gray	555

**Maintenance box part number:** C9345

**Parent topic:** [Purchase Epson Ink and Maintenance Box](#)

## Refilling the Ink Tanks

Make sure you have a new ink bottle handy and have read the ink safety precautions before you begin.

You can continue to use the product even if one or more ink tanks are not filled all the way. However, for the most accurate ink level monitoring, fill all the ink tanks up to the upper line.

**Note:** The product has a low ink alert system. The accuracy of this system depends on the user refilling the ink tanks correctly. The product cannot directly measure the ink levels in the tanks; instead it estimates the amount of ink remaining by internally monitoring ink usage. The low ink alert system may generate inaccurate messages if the ink tanks are not refilled according to these instructions.

As a precaution, perform regular visual inspections of the ink tanks to ensure ink levels do not fall below the lower line. Continued use of the product when the ink level is below the lower line on the tank could damage the product.

**Caution:** If ink spills, wipe it off immediately with a damp towel to avoid permanent stains. If ink gets on your clothes or belongings, it may not come off.

1. Turn on your product.
2. Lift up the scanner unit until it locks into place.

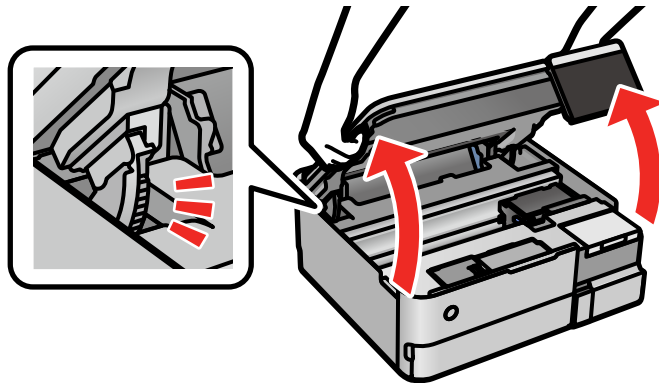

3. Open the ink tank cover, then open the cap for the ink tank you are going to fill.

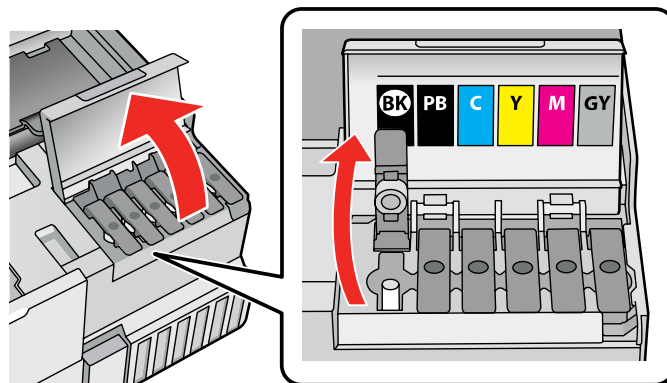

4. Hold the ink bottle upright and slowly turn the bottle cap to remove it.

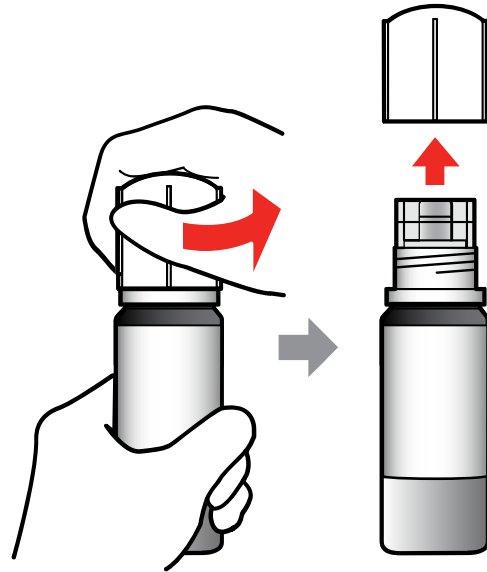

**Caution:** Do not shake or squeeze the ink bottle. Do not touch the top of the bottle after its cap is removed.

**Warning:** If ink gets on your skin, wash it thoroughly with soap and water. If ink gets into your eyes, flush them immediately with water. If ink gets into your mouth, spit it out immediately. Seek medical advice if problems persist. Keep the ink bottles out of the reach of children and do not drink the ink.



5. Insert the ink bottle into the filling port and wait for the ink to fill the tank. Do not squeeze the bottle. Ink flows into the tank and stops automatically when the ink is filled to the upper line.

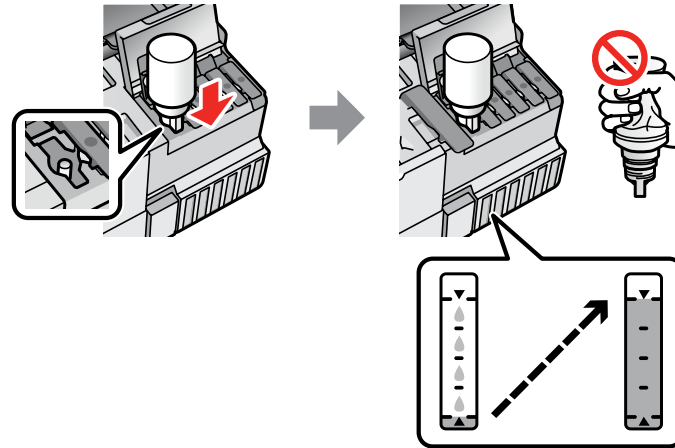

**Note:** Refer to the color-coded sticker on the ink tank unit to identify the color of each tank. Do not force the bottles into position; they are keyed for each color.

**Note:** If ink does not flow from the bottle, lift and reinsert the bottle.

6. When the ink tank is full, remove the ink bottle and securely close it with the cap.

**Note:** If any ink remains in the bottle, store the bottle upright for later use.

7. Close the ink tank cap.

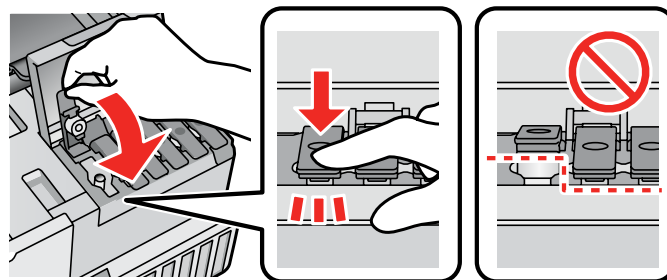

8. Repeat the previous steps as necessary for each ink tank you need to refill.
9. Close the ink tank cover.

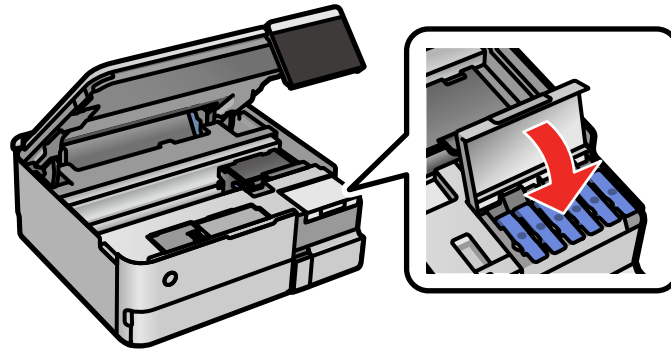

10. Lower the scanner unit.

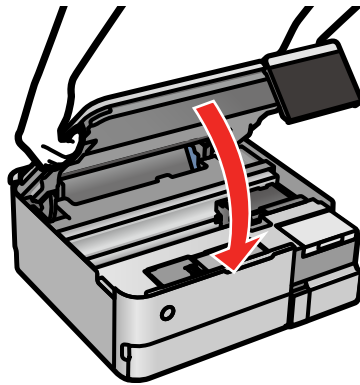

11. Select **Maintenance** > **Fill Ink** and follow the on-screen instructions to reset the ink levels.

**Note:** Make sure you reset the ink levels for all inks you refilled; otherwise, you may get an error message or the ink levels won't change on the LCD screen.

**Parent topic:** [Refilling Ink and Replacing the Maintenance Box](#)

**Related concepts**

[Purchase Epson Ink and Maintenance Box](#)

**Related tasks**

[Checking the Ink Levels on Your Product](#)

## Maintenance Box Replacement

The maintenance box stores surplus ink that gets collected during printing or print head cleaning. When you see a message on the LCD screen, follow the on-screen instructions to replace the maintenance box.

**Note:** When the maintenance box is full, you cannot print or clean the print head until it is replaced. However, you can perform operations that do not require ink, such as scanning.

Note the following precautions when replacing the maintenance box:

- Do not remove the maintenance box or its cover except when replacing the maintenance box; otherwise, ink may leak.
- Do not touch the green chip on the side of the maintenance box.
- Do not tilt the maintenance box after removing it or ink may leak.
- Do not touch the openings in the maintenance box or you may get ink on you.
- Do not drop the maintenance box or subject it to strong shocks.
- If you cannot replace the cover, the maintenance box may not be installed correctly. Remove and reinstall the maintenance box.
- Do not store the maintenance box in high or freezing temperatures.
- Do not replace the maintenance box during printing; otherwise, ink may leak.

**Caution:** Do not reuse a maintenance box that has been removed and left uninstalled for a long period. Keep the maintenance box away from direct sunlight.

**Note:** The maintenance box is a user-replaceable part and is not covered by the product warranty.

**Parent topic:** [Refilling Ink and Replacing the Maintenance Box](#)

**Related concepts**

[Purchase Epson Ink and Maintenance Box](#)

**Related tasks**

[Checking Maintenance Box Status on the LCD Screen](#)

---

## Adjusting Print Quality

If your print quality declines, you may need to run a utility to clean or align the print head.

If running these utilities does not solve the problem, you may need to run a Power Cleaning or clean the paper path.

[Print Head Maintenance](#)

[Print Quality Adjustment](#)

[Power Cleaning](#)

[Cleaning the Paper Guide](#)

[Cleaning the Paper Path](#)

[Cleaning the Translucent Film](#)

[Cleaning the Paper Rollers](#)

[Checking the Number of Sheets Fed](#)

## Print Head Maintenance

If your printouts become too light, or you see dark or light bands across them, you may need to clean the print head nozzles. Cleaning uses ink, so clean the nozzles only if print quality declines.

You can check for clogged nozzles before you clean them so you don't clean them unnecessarily.

**Note:** You may not be able to clean the print head when the ink level in any of the tanks is low. You may have to refill the ink tank first.

If you still see white or dark lines or gaps in your printouts, even after cleaning the print head several times, you can run a Power Cleaning.

[Print Head Nozzle Check](#)

[Print Head Cleaning](#)

**Parent topic:** [Adjusting Print Quality](#)

## Print Head Nozzle Check

You can print a nozzle check pattern to check for clogged nozzles.

[Checking the Nozzles Using the Product Control Panel](#)

[Checking the Nozzles Using a Computer Utility](#)

**Parent topic:** [Print Head Maintenance](#)

## Checking the Nozzles Using the Product Control Panel

You can check the print head nozzles using the control panel on your product.

1. Make sure there are no errors on the LCD screen and the CD/DVD tray is not inserted for printing.
2. Load a few sheets of plain paper in Cassette 2 (lower).
3. Select the  home icon, if necessary.
4. Select **Maintenance** > **Print Head Nozzle Check**.

You see a screen like this:

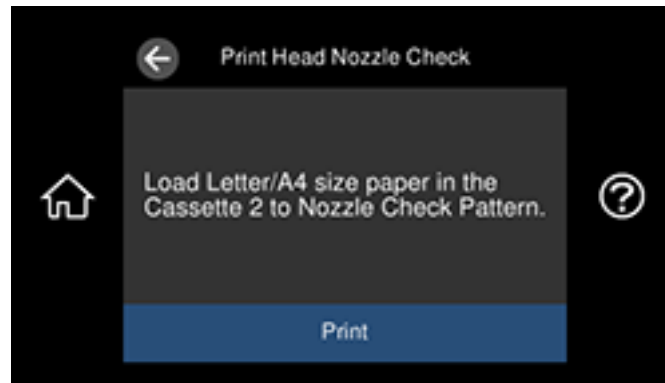

5. Select **Print**.  
The nozzle pattern prints.

6. Check the printed pattern to see if there are gaps in the lines.

**Print head is clean**

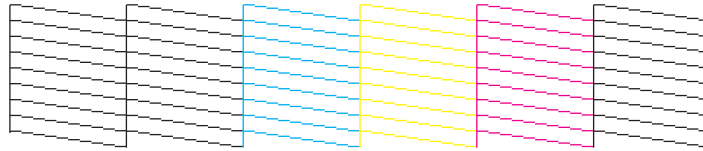

**Print head needs cleaning**

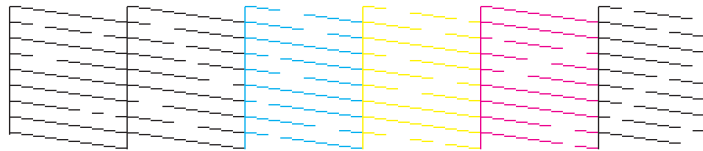

7. Do one of the following:
  - If there are no gaps, select **O**.
  - If there are gaps or the pattern is faint, select **X** and continue with the next step.
8. Follow the instructions on the screen to clean the print head, check the nozzles, and repeat the process if necessary.

**Caution:** Never turn off the product or open the scanner unit during a cleaning cycle or you may not be able to print.

If you don't see any improvement after cleaning the print head up to 3 times, wait at least 12 hours without printing or longer if printing. Then try cleaning the print head again. If quality does not improve, run a Power Cleaning. If quality still does not improve, contact Epson.

**Parent topic:** [Print Head Nozzle Check](#)

**Related concepts**



[Print Head Cleaning](#)

**Related tasks**

[Loading Paper in Cassette 2 \(Lower Cassette\)](#)

## Checking the Nozzles Using a Computer Utility

You can check the print head nozzles using a utility on your Windows or Mac computer.

1. Make sure there are no errors on the LCD screen and the CD/DVD tray is not inserted for printing.
2. Load a few sheets of plain paper in Cassette 2 (lower).
3. Do one of the following:
  - **Windows:** Access the Windows Desktop and right-click the  icon for your product in the right side of the Windows taskbar, or click the up arrow and right-click .
  - **Mac:** In the Apple menu or the Dock, select **System Preferences**. Select **Print & Fax**, **Print & Scan**, or **Printers & Scanners**, select your product, and select **Options & Supplies**. Select **Utility** and select **Open Printer Utility**.
4. Select **Print Head Nozzle Check**.

You see a window like this:

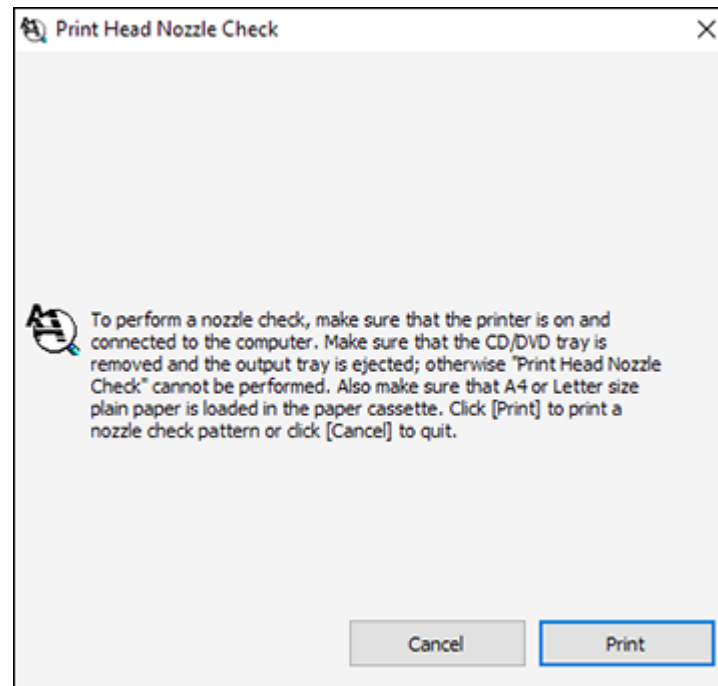



5. Click **Print**.
6. Check the printed pattern to see if there are gaps in the lines.

#### **Print head is clean**

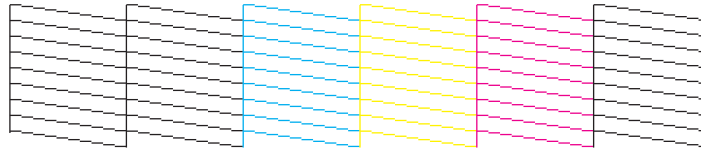

#### **Print head needs cleaning**

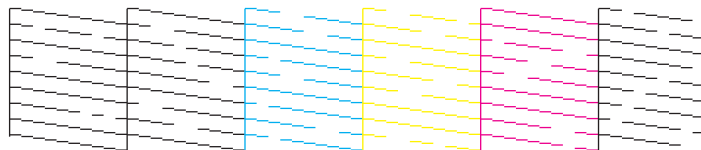

7. Do one of the following:
  - If there are no gaps, click **Finish**.
  - If there are gaps or the pattern is faint, clean the print head.

**Parent topic:** [Print Head Nozzle Check](#)

#### **Related concepts**

[Print Head Cleaning](#)

#### **Related tasks**

[Loading Paper in Cassette 2 \(Lower Cassette\)](#)

## **Print Head Cleaning**

If print quality has declined and the nozzle check pattern indicates clogged nozzles, you can clean the print head.

**Note:** You may not be able to clean the print head when the ink level in any of the tanks is low. You may have to refill the ink tank first.

[Cleaning the Print Head Using the Product Control Panel](#)

[Cleaning the Print Head Using a Computer Utility](#)

**Parent topic:** [Print Head Maintenance](#)

**Related tasks**

[Refilling the Ink Tanks](#)

### **Cleaning the Print Head Using the Product Control Panel**

You can clean the print head using the control panel on your product.

1. Make sure there are no errors on the LCD screen and the CD/DVD tray is not inserted for printing.
2. Load a few sheets of plain paper in Cassette 2 (lower).
3. Select the  home icon, if necessary.
4. Select **Maintenance** > **Print Head Cleaning**.

You see a screen like this:

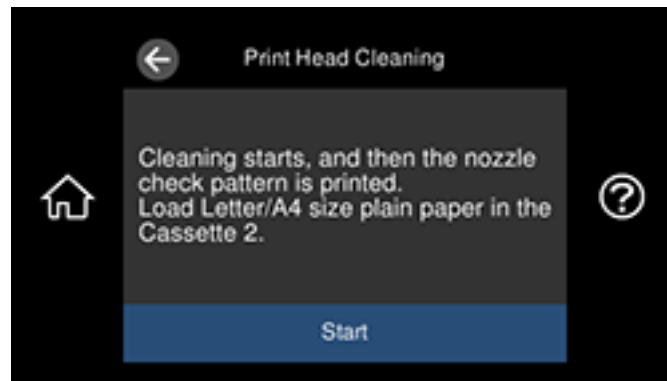

5. Select **Start** to clean the print head.

The  power light flashes throughout the cleaning cycle and stays on when the cleaning cycle is finished. When the cleaning cycle is finished, you see a message on the screen and a nozzle pattern prints.

**Caution:** Never turn off the product or open the scanner unit during a cleaning cycle or you may not be able to print.

6. Check the printed pattern to see if there are gaps in the lines.

**Print head is clean**

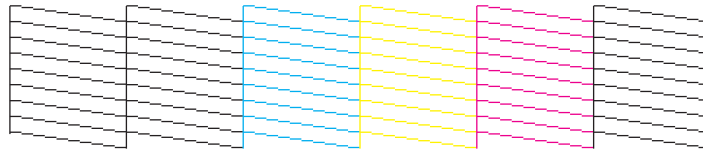

**Print head needs cleaning**

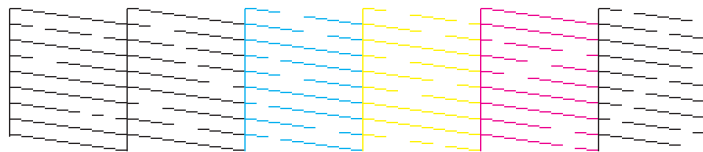

7. Do one of the following:
  - If there are no gaps, select **O**.
  - If there are gaps or the pattern is faint, select **X** and continue with the next step.
8. Follow the instructions on the screen to clean the print head, check the nozzles, and repeat the process if necessary.

If you don't see any improvement after cleaning the print head up to 3 times, wait at least 12 hours without printing or longer if printing. Then try cleaning the print head again. If quality does not improve, run a Power Cleaning. If quality still does not improve, contact Epson.

**Parent topic:** [Print Head Cleaning](#)

**Related concepts**

[Print Head Nozzle Check](#)



**Related tasks**

[Loading Paper in Cassette 2 \(Lower Cassette\)](#)

**Cleaning the Print Head Using a Computer Utility**

You can clean the print head using a utility on your Windows or Mac computer.

1. Make sure there are no errors on the LCD screen and the CD/DVD tray is not inserted for printing.

2. Load a few sheets of plain paper in Cassette 2 (lower).
3. Do one of the following:
  - **Windows:** Access the Windows Desktop and right-click the  icon for your product in the right side of the Windows taskbar, or click the up arrow and right-click .
  - **Mac:** In the Apple menu or the Dock, select **System Preferences**. Select **Print & Fax**, **Print & Scan**, or **Printers & Scanners**, select your product, and select **Options & Supplies**. Select **Utility** and select **Open Printer Utility**.
4. Select **Print Head Cleaning**.

You see a window like this:

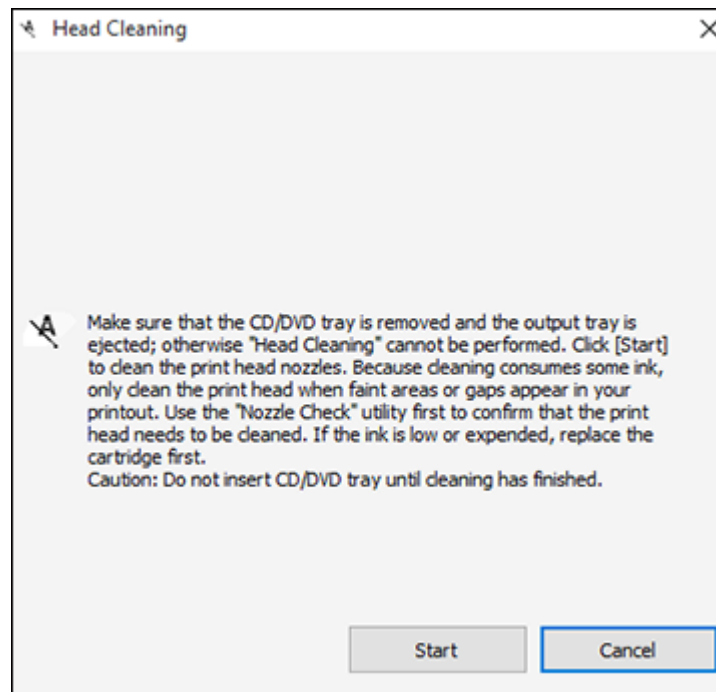

5. Click **Start** to begin the cleaning cycle.

The  power light flashes throughout the cleaning cycle and stays on when the cleaning cycle is finished.

**Caution:** Never turn off the product or open the scanner unit during a cleaning cycle or you may not be able to print.

6. When the cleaning cycle is finished, you can check to see if the nozzles are clean; click **Print Nozzle Check Pattern** and click **Print**.
7. Check the printed pattern to see if there are gaps in the lines.

**Print head is clean**

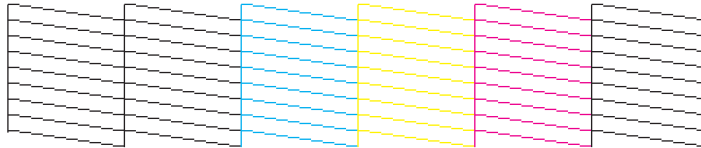

**Print head needs cleaning**

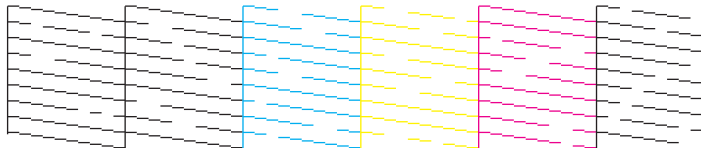

- If there are no gaps, click **Finish**.
- If there are gaps or the pattern is faint, click **Clean** to clean the print head again.

If you don't see any improvement after cleaning the print head up to 3 times, turn off the product and wait at least 12 hours. Then try cleaning the print head again. If quality still does not improve, run a Power Cleaning. If there is still no improvement, contact Epson support.

**Parent topic:** [Print Head Cleaning](#)

**Related concepts**

[Print Head Nozzle Check](#)

**Related tasks**

[Loading Paper in Cassette 2 \(Lower Cassette\)](#)

## Print Quality Adjustment

If your printouts become grainy or blurry, you notice misalignment of vertical lines, or you see dark or light horizontal bands, you may need to adjust the print quality.

**Note:** Banding may also occur if your print head nozzles need cleaning.

[Aligning the Print Head Using the Product Control Panel](#)

**Parent topic:** [Adjusting Print Quality](#)

## Aligning the Print Head Using the Product Control Panel

If your printouts become grainy or blurry, you notice misalignment of vertical lines, or you see dark or light horizontal bands, you may need to align the print head.

**Note:** Banding may also occur if your print head nozzles need cleaning.

1. Make sure there are no errors on the LCD screen and the CD/DVD tray is not inserted for printing.
2. Load a few sheets of plain paper in Cassette 2 (lower).
3. Select the  home icon, if necessary.
4. Select **Maintenance** > **Print Head Alignment**.

You see a screen like this:

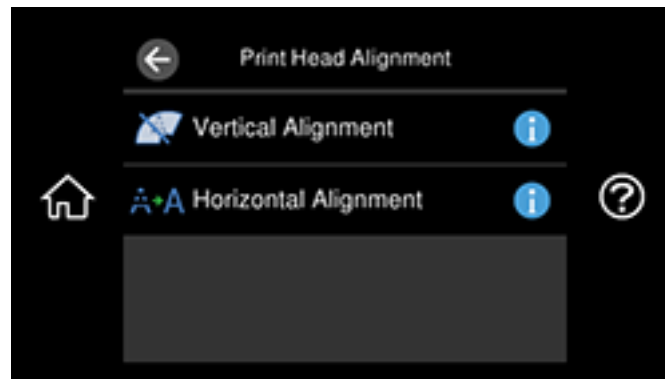

5. Select one of the following options:
  - **Vertical Alignment** if your printout is blurry or contains vertical ruled lines that are misaligned.
  - **Horizontal Alignment** if your printout contains horizontal banding.
6. Follow the on-screen instructions to print an alignment sheet.

**Note:** Do not cancel printing while you are printing head alignment patterns.

7. Check the printed patterns on the alignment sheet and select the following on the LCD screen, depending on the alignment pattern you printed:
  - **Vertical Alignment:** For each set of patterns, select the number representing the pattern with the least amount of separation or overlap.

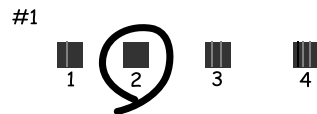

- **Horizontal Alignment:** Select the number representing the pattern with the least amount of separation or overlap.



8. Continue following the rest of the on-screen instructions to finish the alignment.

**Parent topic:** [Print Quality Adjustment](#)

**Related concepts**

[Print Head Nozzle Check](#)

[Print Head Cleaning](#)

### Related tasks

[Loading Paper in Cassette 2 \(Lower Cassette\)](#)  
[Cleaning the Paper Path](#)

## Power Cleaning

If you still see white or dark lines or missing nozzles in your printouts, even after cleaning the print head several times, you can run a Power Cleaning.

If you do not see improvement after running a Power Cleaning, turn off the product and wait at least 12 hours before running another Power Cleaning.

**Caution:** Running a Power Cleaning consumes a lot of ink, so you should run it only if necessary. Make sure each ink tank is at least one-third full before running a Power Cleaning, or it may damage the product.

**Caution:** Power Cleaning may cause the maintenance box to reach its capacity sooner. When the maintenance box is full, you need to replace it to continue printing.

[Power Cleaning Using the Product Control Panel](#)

**Parent topic:** [Adjusting Print Quality](#)

### Related concepts

[Maintenance Box Replacement](#)

### Related tasks

[Refilling the Ink Tanks](#)

## Power Cleaning Using the Product Control Panel

You can run a Power Cleaning using the control panel on your product.

**Note:** After a Power Cleaning, you must turn off the product and wait at least 12 hours before printing a nozzle check pattern and running another Power Cleaning or Print Head Cleaning.

1. Make sure there are no errors on the LCD screen and the CD/DVD tray is not inserted for printing.
2. Load a few sheets of plain paper in Cassette 2 (lower).
3. Select the  home icon, if necessary.
4. Select **Maintenance > Power Cleaning**.



5. Follow the on-screen instructions to proceed.

The  power light flashes throughout the cleaning cycle and stays on until the nozzle check pattern is printed. After the nozzle check pattern is printed, you see a message on the screen.

**Caution:** Never turn off the product or open the scanner unit during a cleaning cycle or you may not be able to print.

If the print quality did not improve, turn off the product and wait at least 12 hours before printing another nozzle check pattern and running another Power Cleaning or Print Head Cleaning.

If the print quality does not improve after running the Power Cleaning utility multiple times, contact Epson for support.

**Parent topic:** [Power Cleaning](#)

**Related concepts**

[Print Head Nozzle Check](#)

[Print Head Cleaning](#)

**Related references**

[Where to Get Help](#)

**Related tasks**

[Loading Paper in Cassette 2 \(Lower Cassette\)](#)

## Cleaning the Paper Guide

If you see ink on the back of a printout, you can clean the paper guide rollers to remove any excess ink.

1. Make sure there are no errors on the LCD screen and the CD/DVD tray is not inserted for printing.
2. Load plain paper in one of these sizes in the rear paper feeder: Letter (8.5 × 11 inches [216 × 279 mm]) or A4 (8.3 × 11.7 inches [210 × 297 mm]).
3. Select the  home icon, if necessary.
4. Select **Maintenance > Paper Guide Cleaning**.

You see a screen like this:

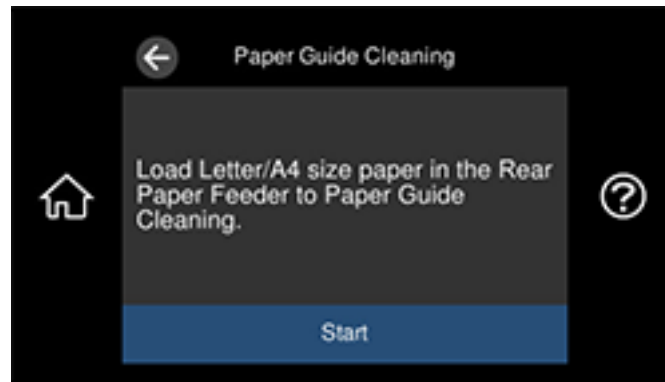

5. Follow the on-screen instructions to clean the paper guide.
6. Repeat these steps as necessary until the paper comes out clean.  
If the paper is still smeared with ink, follow the next steps.
7. Turn off the product.
8. Unplug the power cord, and then disconnect it from the product.
9. Disconnect any connected cables.

10. Gently pull out the output tray.

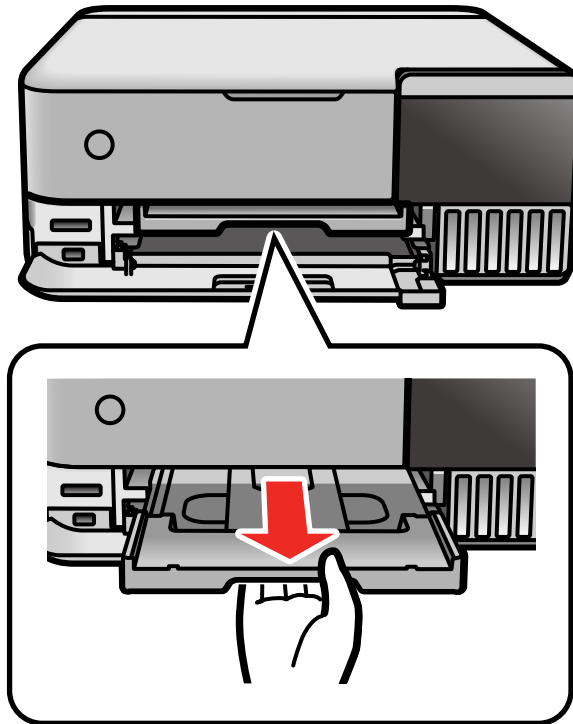

11. Moisten a cotton swab with a little water.

12. Use the cotton swab to wipe the two white rollers. Gently rotate the rollers to clean them completely.

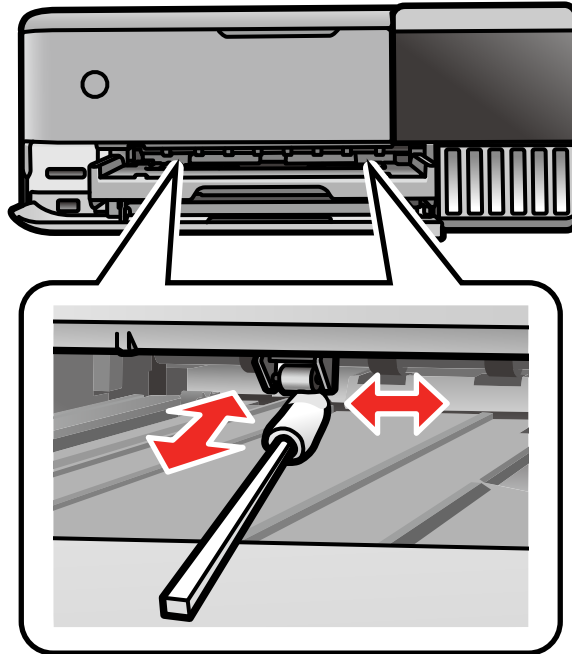

**Caution:** Do not use tissue paper to clean the rollers. The print head nozzles may be clogged with lint.

13. Connect the power cord and any interface cables.

**Parent topic:** [Adjusting Print Quality](#)

**Related tasks**

[Loading Paper in the Rear of Your Product](#)

## Cleaning the Paper Path

If the print quality has not improved after aligning the print head and cleaning the paper path, the paper path inside the product may be smeared with ink.

1. Turn off the product.
2. Unplug the power cable.

3. Disconnect any connected cables.
4. Open the scanner unit.

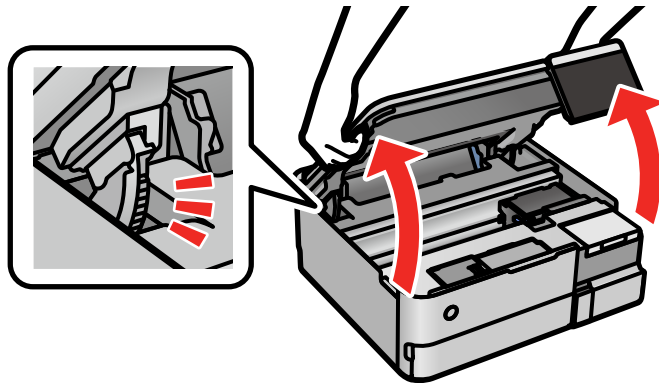

**Caution:** Do not touch the areas shown below. Doing so may cause a malfunction.

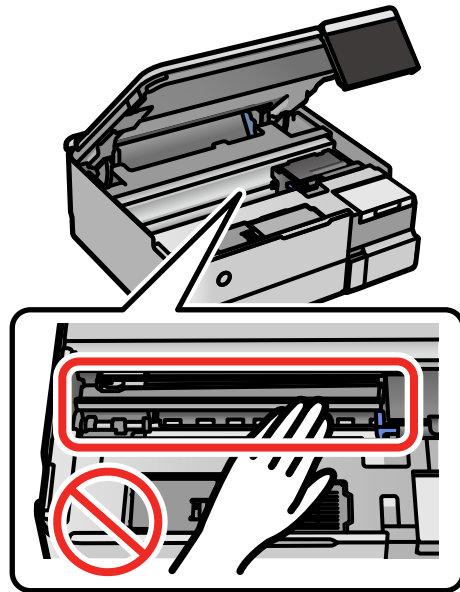

5. Use a cotton swab to wipe off ink from the parts inside the product as shown.

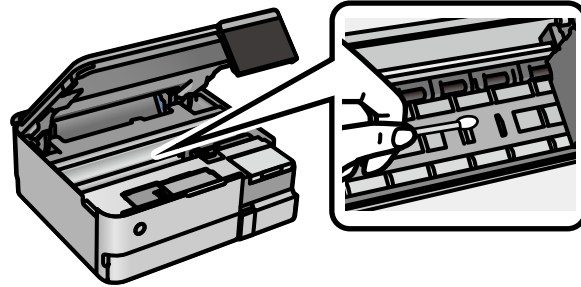

**Caution:** Do not use tissue to clean the inside of the product; the print head nozzles may become clogged with lint.

6. Close the scanner unit.
7. Reconnect any disconnected cables, plug in the power cord, and turn on the product.

**Parent topic:** [Adjusting Print Quality](#)

**Related tasks**

[Aligning the Print Head Using the Product Control Panel](#)

## Cleaning the Translucent Film

If the print quality has not improved after aligning the print head and cleaning the paper path, the translucent film inside the product may be smeared with ink.

To clean the printer head path, use the following:

- Several cotton swabs
- ¼ cup (59 ml) water containing 2 to 3 drops of mild dish detergent
- A small flashlight

**Caution:** Do not use any other liquid to clean the printer head path or you may damage your product.

1. Turn off the product.
2. Unplug the power cable.
3. Disconnect any connected cables.

4. Open the scanner unit.

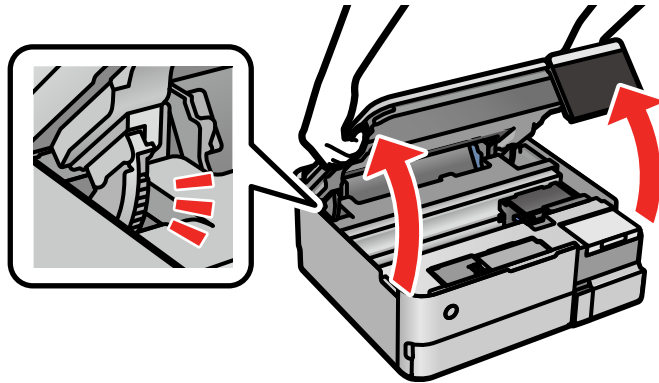

5. Using the flashlight, check the translucent film shown here for ink smears.

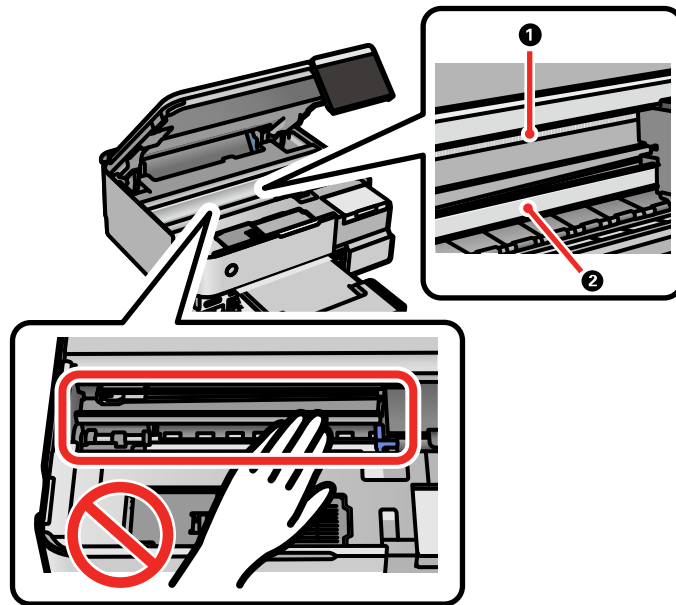

1 Translucent film

## 2 Print head rail

**Caution:** Do not touch the print head rail or you may not be able to print. Do not wipe off the grease on the rail.

6. Moisten a cotton swab with the water and detergent mixture and squeeze out any excess moisture, then lightly wipe the ink off the translucent film.

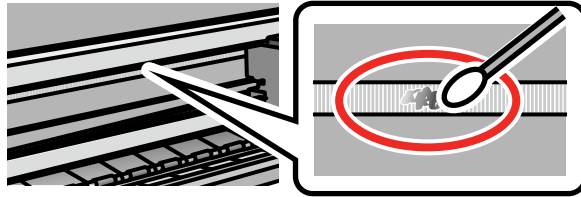

**Caution:** Do not press too hard on the film or you may dislocate the anchor springs and damage your product.

7. Use a new, dry cotton swab to dry the translucent film.
8. Repeat steps 6 and 7 as necessary to clean all ink smears.
9. When the translucent film is dry and free of any fibers, close the scanner unit.
10. Reconnect any disconnected cables, plug in the power cord, and turn on the product.

**Parent topic:** [Adjusting Print Quality](#)

### **Related tasks**

[Aligning the Print Head Using the Product Control Panel](#)

## **Cleaning the Paper Rollers**

If you encounter repeated paper feed issues from the cassette, clean the paper rollers inside the product.

1. Turn off the product.
2. Unplug the power cable.
3. Disconnect any connected cables.



4. Open the scanner unit.

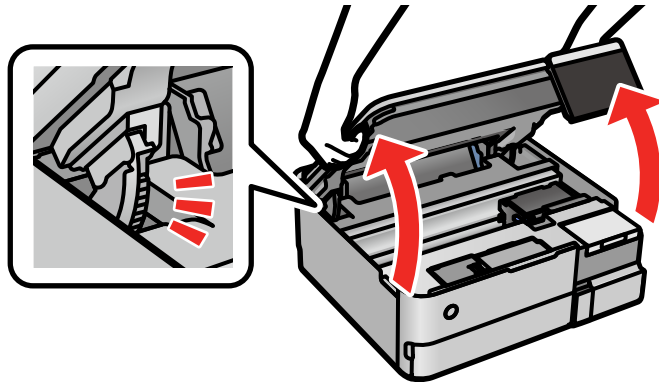

5. Make sure the ink tank caps are securely closed.

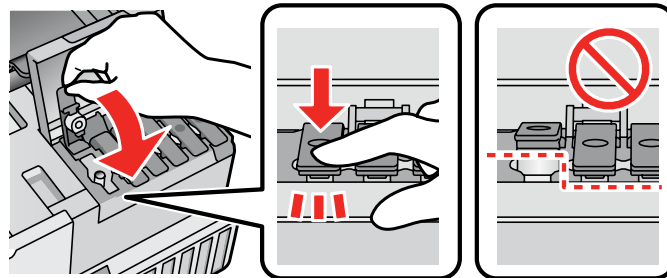

6. Close the ink tank cover and the scanner unit.

7. Remove the paper cassettes.

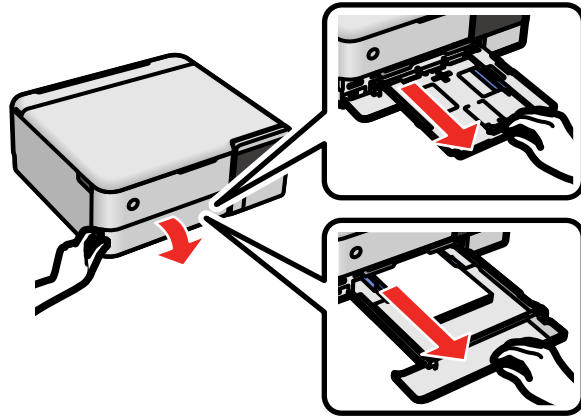

8. Place the product on its side with the ink tank on the bottom.

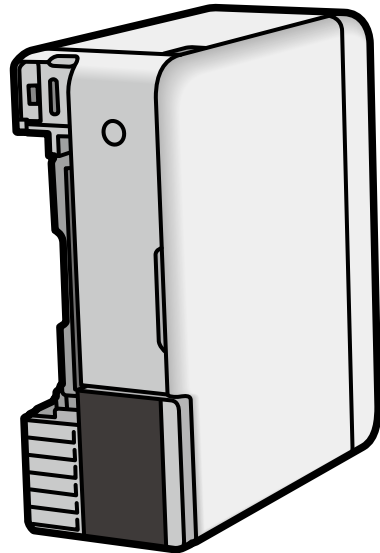

**Warning:** Be careful not to trap your fingers under the product.

9. Use a soft, moist cloth to clean the paper rollers, as shown. Rotate the rollers to clean them thoroughly.

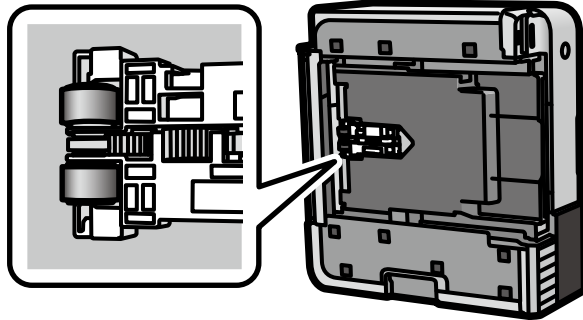

10. Return the product to its normal position.

**Caution:** Do not leave the product on its side for an extended period of time.

11. Slide in the paper cassettes, and connect the power cord and any interface cables.

**Parent topic:** [Adjusting Print Quality](#)

## Checking the Number of Sheets Fed

You can view an option that displays the number of sheets of paper that have fed through the product.

**Note:** You can also view the number of sheets of paper fed through the product by printing a nozzle check.

[Checking the Number of Sheets on the LCD Screen](#)

[Checking the Sheet Counter - Windows](#)

[Checking the Sheet Counter - Mac](#)

**Parent topic:** [Adjusting Print Quality](#)

**Related concepts**

[Print Head Nozzle Check](#)

## Checking the Number of Sheets on the LCD Screen



You can view the total number of prints, black-and-white prints, and color prints that have been printed.

1. Select the  home icon, if necessary.
2. Select **Settings** > **Print Counter** to view the number of prints.

**Parent topic:** [Checking the Number of Sheets Fed](#)

## Checking the Sheet Counter - Windows

You can check the number of sheets of paper that have fed through the product by checking the sheet counter.

1. Access the Windows Desktop and right-click the  icon for your product in the right side of the Windows taskbar, or click the up arrow and right-click .
2. Select **Printer Settings**.
3. Click the **Maintenance** tab.
4. Select **Printer and Option Information**.

You see this window:

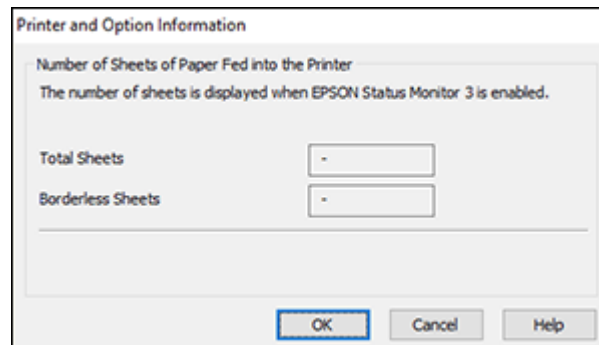

5. After checking the number of sheets fed into the printer, click **OK** to close the window.

**Note:** The number of sheets is displayed only when Epson Status Monitor 3 is enabled.

**Parent topic:** [Checking the Number of Sheets Fed](#)

## Checking the Sheet Counter - Mac

You can check the number of sheets of paper that have fed through the product by checking the sheet counter.

1. Select **Printer and Option Information**.

You see this window:

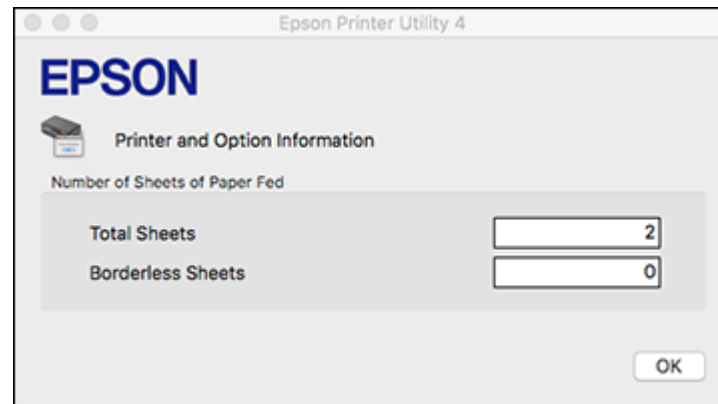

2. After checking the number of sheets fed into the printer, click **OK** to close the window.

**Parent topic:** [Checking the Number of Sheets Fed](#)

---

# Cleaning and Transporting Your Product

See these sections if you need to clean or transport your product.

[Cleaning Your Product](#)

[Transporting Your Product](#)

## Cleaning Your Product

To keep your product working at its best, you should clean it several times a year.

**Caution:** Do not use alcohol or paint thinner to clean the product or you may damage it. Do not use oil, chemical cleaners, or other lubricants inside the product or let water get inside it. Close the rear paper feed slot when you are not using it, to keep out dust.

1. Turn off the product.
2. Clean the outer case and control panel with a soft, clean cloth moistened with a little water.

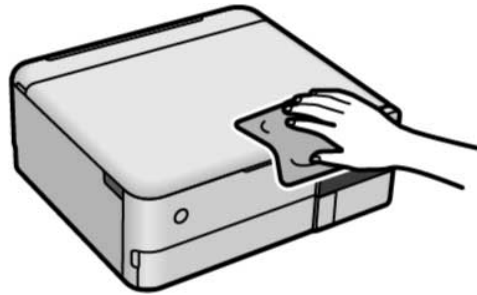

3. Open the document cover.

4. Clean the scanner glass and the document cover with a soft, dry, clean cloth. If necessary, use a small amount of glass cleaner on the cloth.

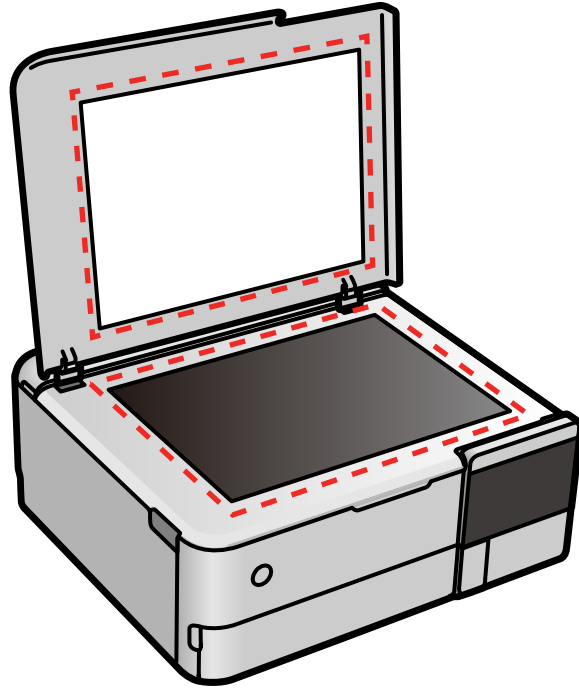

**Caution:** Do not spray glass cleaner directly on the glass and wipe off all remaining liquid. Do not press the glass surface with any force.

Parent topic: [Cleaning and Transporting Your Product](#)

## Transporting Your Product

If you need to store your product or transport it a long distance, prepare it for transportation as described here.

**Caution:** During transportation and storage, follow these guidelines:

- When lifting the printer, place your hands in the positions shown below. Do not hold printer at the front and back. When carrying the printer, hold it steadily to prevent injury.

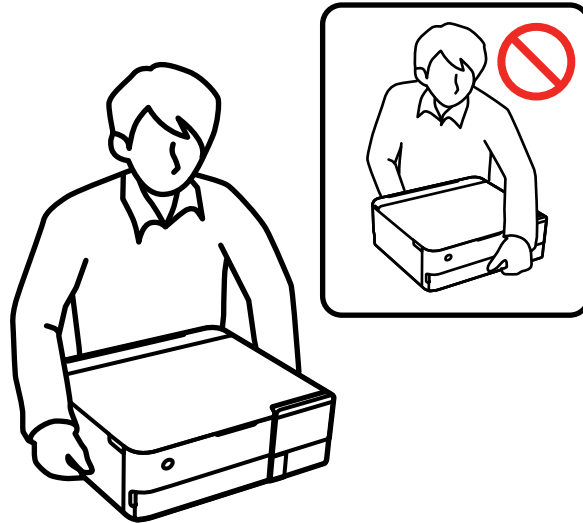



- Avoid tilting the product, placing it vertically, or turning it upside down; otherwise ink may leak. When storing or transporting the printer, place it in a plastic bag and fold it closed.



- When storing or transporting an ink bottle after removing its seal, do not tilt the bottle and do not subject it to impacts or temperature changes. Otherwise, ink may leak even if the cap on the ink bottle is tightened securely. Be sure to keep the ink bottle upright when tightening the cap, and take measures to prevent ink from leaking when transporting the ink bottles.
- Do not put opened ink bottles in the box with the product.
  1. If the output tray is opened, select **Output Tray** on the Home screen to close it.
  2. Remove all the paper from the product and make sure there are no originals on the scanner glass.

3. Close the rear paper feeder and the front cover as shown below.

**L8160:**

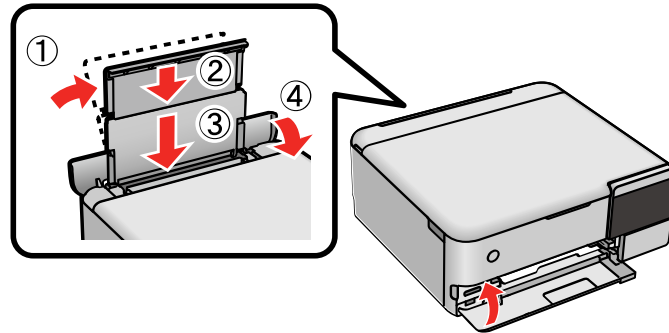

**L8180:**

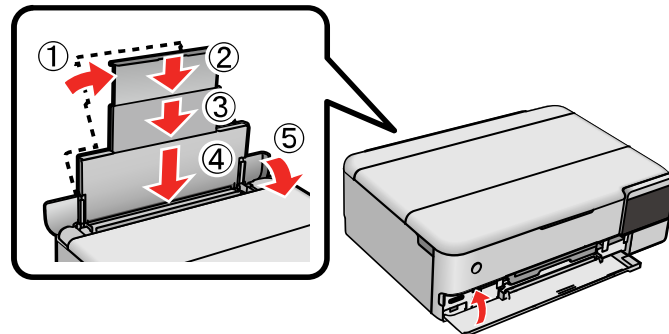

4. Turn off the product.
5. Wait for the  power light to turn off, then unplug the power cable.

**Caution:** Do not unplug the power cable before the power light is off. Otherwise, the print head does not return to the home position and the ink can dry out, making printing impossible.

6. Disconnect any connected cables.

7. Lift up the scanner unit.

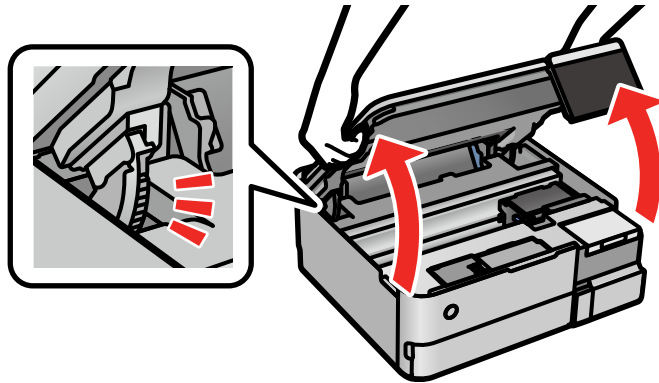

8. Make sure the print head is in the home position on the right and move the transportation lock to the transport position.

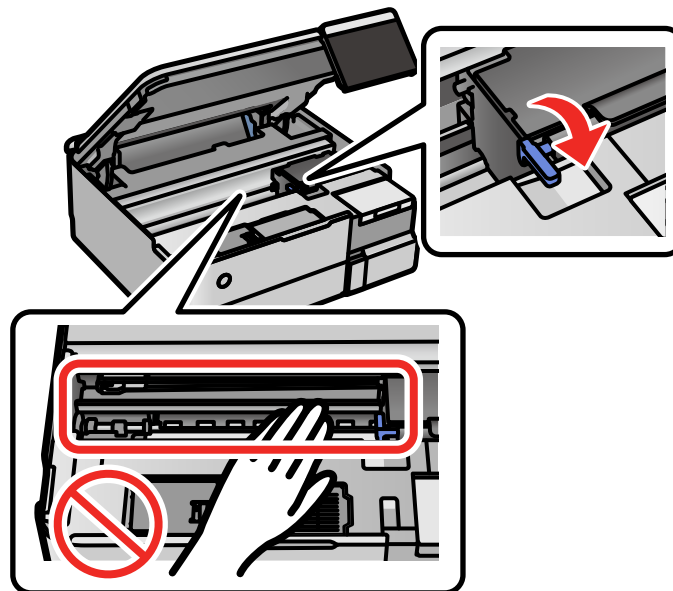

**Caution:** Do not touch the translucent film inside the product; otherwise, you may damage your product.

9. Open the ink tank cover.

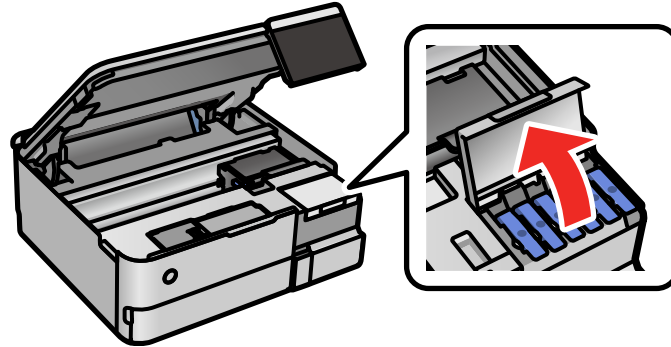

10. Make sure the ink tank caps are securely closed.

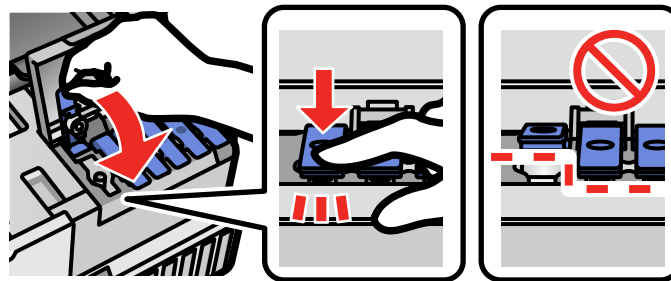

11. Close the ink tank cover.

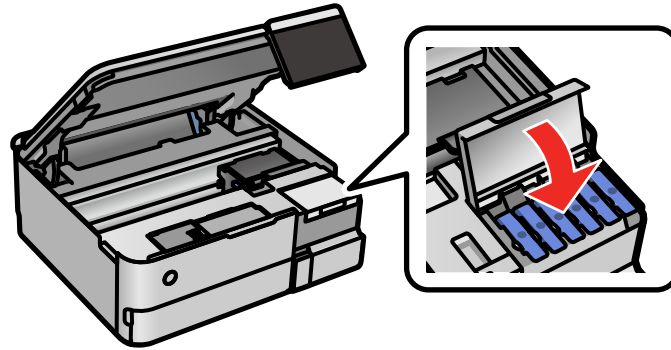

12. Secure the print head to the case with tape as shown.

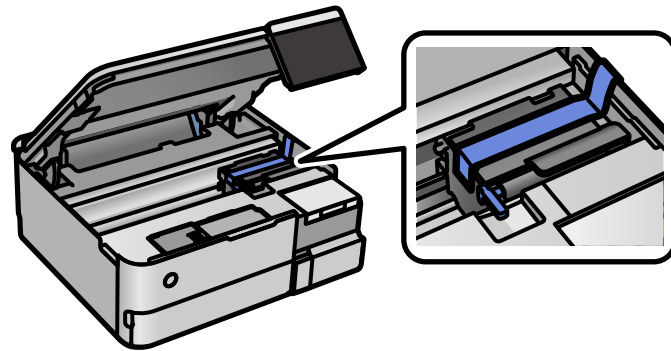

13. Lower the scanner unit.

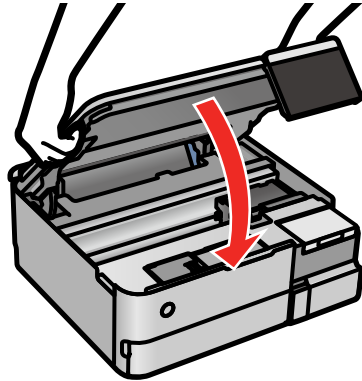

**Caution:** Be careful not to trap your hand or fingers when closing the scanner unit. Otherwise, you may be injured.

14. Place the printer in the plastic bag supplied with your product and fold it closed.

15. Place the product in its original packing materials, if possible, or use equivalent materials with cushioning around the product.

Keep the product level during transportation. If print quality has declined when you print again, clean and align the print head. Make sure you remove the tape securing the print head before using the printer.

**Parent topic:** [Cleaning and Transporting Your Product](#)

**Related concepts**

[Print Head Cleaning](#)

[Print Quality Adjustment](#)

---

# Solving Problems

Check these sections for solutions to problems you may have using your product.

[Checking for Software Updates](#)

[Viewing the Help Screen](#)

[Product Status Messages](#)

[Running a Product Check](#)

[Resetting Control Panel Defaults](#)

[Solving Setup Problems](#)

[Solving Network Problems](#)

[Solving Copying Problems](#)

[Solving Paper Problems](#)

[Solving Problems Printing from a Computer](#)

[Solving Page Layout and Content Problems](#)

[Solving Print Quality Problems](#)

[Solving Scanning Problems](#)

[Solving Scanned Image Quality Problems](#)

[Solving Memory Card Problems](#)

[Solving USB Device Problems](#)



[Solving CD/DVD Problems](#)

[Uninstall Your Product Software](#)

[Where to Get Help](#)

## Checking for Software Updates

It's a good idea to check Epson's support website occasionally for free updates to your product software. Visit [latin.epson.com/support](http://latin.epson.com/support) and select your product.

- **Windows:** Your printer software automatically checks for updates. You can also manually update the software by selecting **Software Update** here:
  - Accessing the Windows Desktop and right-clicking the  icon for your product in the right side of the Windows taskbar, or clicking the up arrow and right-clicking .
  - On the **Maintenance** tab in the printer settings window

You can also update the software by selecting **EPSON Software Updater** in the **EPSON** or **Epson Software** program group, accessible by the **Start** button, or on the **Start** or **Apps** screens, depending on your version of Windows.

- **OS X:** You can manually update the software by opening the **Applications > Epson Software** folder and selecting **EPSON Software Updater**.
- **macOS 10.12.x, 10.13.x, 10.14.x, 10.15.x, or 11.x:** You can manually update the software by opening the **App Store**, selecting **Updates**, searching for a software update option for Epson Software, and selecting **Update**.

Parent topic: [Solving Problems](#)

## Viewing the Help Screen

You can view troubleshooting or how-to topics on the LCD screen at any time.

1. Select the  help icon.

You see this screen:

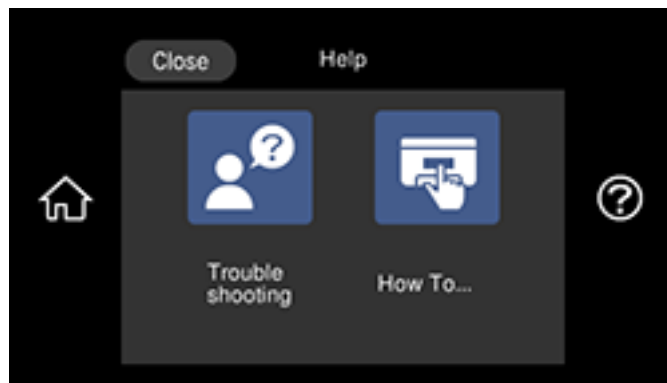

2. Select an option to view instructional images or animations.

Parent topic: [Solving Problems](#)

## Product Status Messages

You can often diagnose problems with your product by checking the messages on its LCD screen. You can also select the  help icon to see help information and how-to instructions on the screen.



LCD screen message	Condition/solution
Printer error. Turn the power off and on again. If the problem persists, press "Proceed."	Turn the product off and then back on again. If the error continues, check for a paper jam or any protective material inside the product. If there is no paper jam or protective material, contact Epson for support.
An error occurred while saving. Check and if necessary, change the memory device.	The external storage device, such as a memory card, may be damaged. Check the device.
Have you loaded the following paper in the XX?	Load the size and type of paper in the indicated paper source. Change the paper or print settings as necessary.
The printer's borderless printing ink pad is nearing the end of its service life. It is not a user-replaceable part. Please contact Epson support.	The ink pads are near the end of their service life and the message will be displayed until the ink pad is replaced. Contact Epson for support. (To resume printing, select <b>OK</b> .)
The printer's borderless printing ink pad has reached the end of its service life. It is not a user-replaceable part. Please contact Epson support.	The ink pad is at the end of its service life. Borderless printing is not available, but printing with a border is available. Turn off the product and contact Epson for support.
Paper Configuration is set to Off. Some features may not be available. For details, see your documentation.	The <b>Paper Configuration</b> setting must be enabled to use AirPrint. Select <b>Settings &gt; Printer Settings &gt; Paper Source Setting &gt; Paper Configuration</b> .
Communication error. Check if the computer is connected.	Make sure the computer and product are connected. For scanning, make sure that Epson Scan 2, Epson ScanSmart, and Event Manager are installed on the computer.

LCD screen message	Condition/solution
The combination of the IP address and subnet mask is invalid. See your documentation for more details.	There is a problem with the network connection to your product. Check the solutions in the links at the end of this topic.
To use cloud services, update the root certificate from the Epson Web Config utility.	Access your product's built-in Web Config utility and update the root certificate for your product.
Cannot recognize the media. See your documentation for more details about the media.	Make sure the external storage device meets the specifications.
Cannot use the inserted Memory Device. See your documentation for details.	
Print Head Adjustment Canceled. There is a problem with the print head. Contact Epson Support.	If print quality has not improved after running a nozzle check and cleaning the print head three times, turn off the product and wait at least 12 hours. Then run a nozzle check and try cleaning the print head again. If print quality has still not improved, run a Power Cleaning. If it still has not improved after that, contact Epson for support.
Install the Epson Event Manager software on the computer to use this feature. See your documentation for more details.	Make sure Epson Event Manager and Epson ScanSmart are installed on your computer.

LCD screen message	Condition/solution
<p>Check the following if a computer is not found.</p> <ul style="list-style-type: none"> <li>- Connection between the printer and the computer (USB or network)</li> <li>- Installation of the necessary software</li> <li>- Power supply to the computer</li> <li>- Firewall and security software settings</li> <li>- Search again</li> </ul> <p>See your documentation for more details.</p>	<p>Make sure your product and computer are properly connected and all necessary software is installed. Make sure the computer is turned on. You may need to adjust the settings in your firewall or security software.</p>
<p>Printing canceled because the long paper might eject halfway through printing. Set the paper length shorter than 1300 mm. See your documentation for details.</p>	<p>Make sure you are printing in an environment that is lower than 90°F (32°C). Make sure the paper length is shorter than 51 inches (1.3 m).</p>
<p>Printing canceled because the long paper might eject halfway through printing. Set the Quality to Standard. See your documentation for details.</p>	<p>The print data size is too large. Set the print quality setting in the printer driver to <b>Standard</b>.</p>

LCD screen message	Condition/solution
Check that the printer driver is installed on the computer and that the port settings for the printer are correct.	Make sure the printer port is selected correctly on the Port tab of the Printer Properties screen (Windows) or the <b>System Properties &gt; USB</b> list (Mac). Select <b>USBXXX</b> for a USB connection or <b>EpsonNet Print Port</b> for a network connection.
Check that the printer driver is installed on the computer and that the USB port settings for the printer are correct.	
Access the following or see documentation for details. Select [Dismiss] after confirming it.	Make sure your smartphone is connected for wireless printing.
Recovery mode Firmware Update	An error has occurred during firmware updating. Connect your product using a USB cable and try updating the firmware again. If you still receive this error message, contact Epson for support.

**Note:** The ink pads in the printer collect, distribute, and contain the ink that is not used on printed pages. During the life of your product it may reach a condition where either satisfactory print quality cannot be maintained or the ink pads have reached the end of their usable life. The Epson Status Monitor, your LCD screen, or lights on the control panel will advise you when these parts need replacing. If this happens during the standard warranty of the product, the exchange of the product or replacement of the pads is covered under the standard warranty. If the product is out of warranty, the pads can be replaced by any Epson authorized service provider. The waste ink pads are not a user-replaceable part.

**Parent topic:** [Solving Problems](#)

**Related concepts**

[Uninstall Your Product Software](#)

[Maintenance Box Replacement](#)

**Related references**

[Where to Get Help](#)

[Memory Card Specifications](#)

[External Device Specifications](#)

### Related tasks

[Refilling the Ink Tanks](#)

[Using AirPrint](#)

[Checking for Software Updates](#)

### Related topics

[Wi-Fi or Wired Networking](#)

[Solving Paper Problems](#)

[Solving Network Problems](#)

[Solving Problems Printing from a Computer](#)

## Running a Product Check

Running a product check helps you determine if your product is operating properly.

1. Disconnect any interface cables connected to your product.
2. Make sure there are no errors on the LCD screen and the CD/DVD tray is not loaded.
3. Load plain paper in Cassette 2 (lower).
4. Select the  home icon, if necessary.
5. Select **Maintenance > Print Head Nozzle Check**.

You see a screen like this:

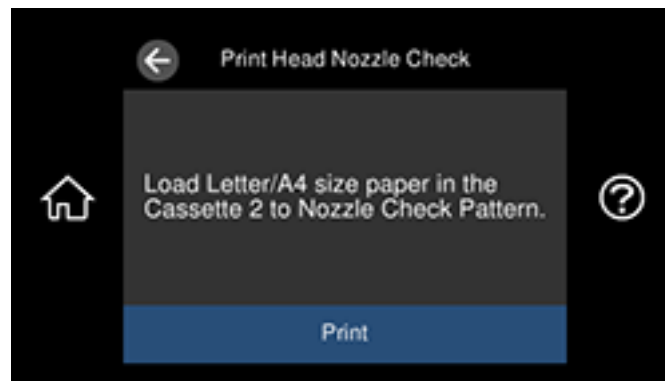

6. Select **Print**.

The nozzle pattern prints.

7. Do one of the following, depending on the results of the product check:
  - If the page prints and the nozzle check pattern is complete, the product is operating properly. Any operation problem you may have could be caused by your computer, cable, software, or selected settings. Check the other solutions in this manual or try uninstalling and reinstalling your printer software.
  - If the page prints but the nozzle check pattern has gaps, clean the print head.
  - If the page does not print, the product may have a problem. Check the other solutions in this manual. If they do not work, contact Epson.

**Parent topic:** [Solving Problems](#)

**Related concepts**

[Uninstall Your Product Software](#)

[Print Head Cleaning](#)

[Power Cleaning](#)

**Related tasks**

[Loading Paper in Cassette 2 \(Lower Cassette\)](#)

[Aligning the Print Head Using the Product Control Panel](#)

## Resetting Control Panel Defaults

If you have a problem with settings on the product control panel, you can reset them to their factory defaults. You can choose which settings to reset or reset them all.

1. Select the  home icon, if necessary.
2. Select **Settings > Restore Default Settings**.

You see a screen like this:

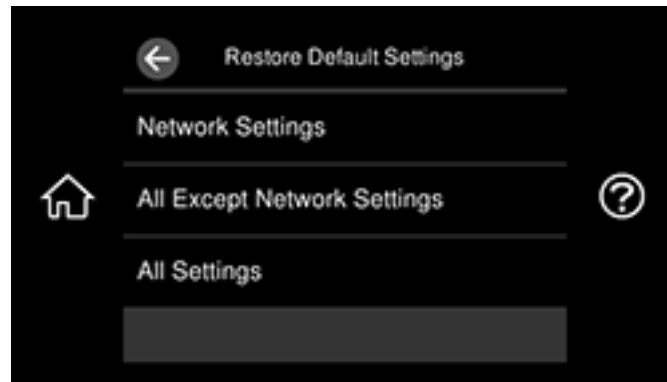

3. Select one of these options:
  - **Network Settings:** Resets all network settings
  - **All Except Network Settings:** Resets all settings except for network settings
  - **All Settings:** Resets all control panel settings

You see a confirmation screen.

4. Select **Yes** to reset the selected settings. (Select **No** if you want to cancel the operation.)

**Parent topic:** [Solving Problems](#)

## Solving Setup Problems

Check these sections if you have problems while setting up your product.

[Product Does Not Turn On or Off](#)

[Noise After Filling the Ink](#)

[Message Appears Prompting You to Reset Ink Levels](#)

[Software Installation Problems](#)

**Parent topic:** [Solving Problems](#)

## Product Does Not Turn On or Off

If you cannot turn the product on or off, try these solutions:

- If you cannot turn on your product, make sure the power cord is securely connected and hold down the power button a little longer.
- If you cannot turn off your product, hold down the power button a little longer. If you still cannot turn off your product, unplug the power cord, plug the power cord back in, then turn your product on and off again using the power button.

**Parent topic:** [Solving Setup Problems](#)

## Noise After Filling the Ink

If you hear noises from your product after filling the ink tanks with ink, check these explanations:

- The first time you fill the tanks with ink, the product must charge its print head. Wait until charging finishes before you turn off the product, or it may charge improperly and use excess ink the next time you turn it on. Your product is finished charging the print head when the  power light stops flashing.
- If the product's print head stops moving or making noise, and the charging process has not finished after approximately 20 minutes, turn off your product. Turn it back on and check to see if charging is still in progress. If it is still in progress, contact Epson for help.

**Parent topic:** [Solving Setup Problems](#)

### Related references

[Where to Get Help](#)

## Message Appears Prompting You to Reset Ink Levels

If you see a message on the LCD screen prompting you to reset the ink levels, do the following:

1. Refill all of the ink tanks or the ink tanks indicated on the LCD screen all the way to the top.

**Note:** Depending on the operating conditions, you may see the ink reset message even when there is still ink in the tanks.

2. Select the colors that you refilled on the LCD screen.
3. Follow the instructions on the LCD screen to reset the ink levels.

**Note:** The product has a low ink alert system. The accuracy of this system depends on the user refilling the ink tanks correctly. The product cannot directly measure the ink levels in the tanks; instead it



estimates the amount of ink remaining by internally monitoring ink usage. The low ink alert system may generate inaccurate messages if the ink tanks are not refilled according to these instructions.

As a precaution, perform regular visual inspections of the ink tanks to ensure ink levels do not fall below the lower line. Continued use of the product when the ink level is below the lower line on the tank could damage the product.

**Parent topic:** [Solving Setup Problems](#)

## Software Installation Problems

If you have problems while installing your product software, try these solutions:

- Make sure your product is turned on and any necessary cables are securely connected at both ends. If you still have problems installing software, disconnect the cable and carefully follow the instructions on the *Start Here* sheet. Also make sure your system meets the requirements for your operating system.
- Close any other programs, including screen savers and virus protection software, and install your product software again.
- In Windows, make sure your product is selected as the default printer and the correct port is shown in the printer properties.
- If you see any error message or your software does not install correctly in Windows, you may not have software installation privileges. Contact your system administrator.
- If you are printing over a network, make sure your product is set up properly on the network.

**Parent topic:** [Solving Setup Problems](#)

### Related concepts

[Uninstall Your Product Software](#)

### Related references

[Windows System Requirements](#)

[Mac System Requirements](#)

## Solving Network Problems

Check these solutions if you have problems setting up or using your product on a network.

**Note:** Breakdown or repair of this product may cause loss of network data and settings. Epson is not responsible for backing up or recovering data and settings during or after the warranty period. We recommend that you make your own backup or print out your network data and settings.

Product Cannot Connect to a Wireless Router or Access Point  
Network Software Cannot Find Product on a Network  
Product Does Not Appear in Mac Printer Window  
Wireless Network Connection is Unstable on a Mac  
Wired Network Connection Becomes Unstable  
Cannot Print Over a Network  
Cannot Scan Over a Network

**Parent topic:** [Solving Problems](#)

## Product Cannot Connect to a Wireless Router or Access Point

If your product has trouble finding or connecting to a wireless router or access point, try these solutions:

- If you are connecting the product via Wi-Fi Protected Setup (WPS) and the Wi-Fi icon on your product's LCD screen is not lit or does not appear, make sure you select one of the WPS options from the product control panel within 2 minutes of pressing the WPS button on your router.
- Make sure to place your product within contact range of your 2.4 GHz router or access point. Avoid placing your product near a microwave oven, 2.4 GHz cordless phone, or large metal object, such as a filing cabinet.

**Note:** If you are using a 5 GHz wireless router, set the router to operate in dual band (2.4 GHz and 5 GHz) mode. If your router uses a single network name (SSID) for both the 2.4 GHz and 5 GHz band, give each band its own network name (SSID) instead, such as Home Network 2.4 GHz and Home Network 5 GHz. See your router documentation or contact your internet service provider for instructions.

- Verify that your router or access point is operating correctly by connecting to it from your computer or another device.
- Print a network connection report and check the codes and messages on the report to help determine the cause of the problem.
- You may need to disable the firewall and any anti-virus software on your wireless router or access point.
- Try restarting your router following the instructions in your router documentation.

**Note:** If you are reading these instructions online, you will lose your Internet connection when you restart your router.

- Check to see if access restrictions, such as MAC address filtering, are set on the router or access point. If access restrictions are set, add your product's MAC address to your router's address list. To obtain your product's MAC address, print a network status sheet. Then follow the instructions in your router or access point documentation to add the address to the list.
- If your router or access point does not broadcast its network name (SSID), follow the instructions that came with your product to enter your wireless network name manually.
- If your router or access point has security enabled, determine the kind of security it is using and any required password or passphrase for connection. Then make sure to enter the exact WEP key or WPA passphrase correctly.
- Check if your computer is restricting the available wireless channels. If so, verify that your wireless access point is using one of the usable channels and change to a usable channel, if necessary.
- If you cannot connect your product to a device using Wi-Fi Direct, you may have exceeded the maximum number of devices connected to your product (8). Print a network status sheet or access Web Config on the browser for your device and check the number of connected devices. If 8 devices are already connected, disconnect a device by deleting the product's SSID from the Wi-Fi screen of that device. If fewer than 8 devices are connected, check the accuracy of your other network settings, move your device closer to your product, and try connecting again.
- If you are using a Wi-Fi Direct connection that suddenly disconnects, the Wi-Fi direct password on your device may have been changed. If necessary, delete the existing **DIRECT-xxxxxxx** connection settings from your device and enter a new password. See your device documentation for instructions.

**Parent topic:** [Solving Network Problems](#)

#### **Related tasks**

[Enabling Wi-Fi Direct Mode \(Simple AP\)](#)

[Selecting Wireless Network Settings from the Control Panel](#)

[Printing a Network Status Sheet](#)

[Printing a Network Connection Report](#)

#### **Related topics**

[Wi-Fi or Wired Networking](#)

## **Network Software Cannot Find Product on a Network**

If EpsonNet Setup cannot find your product on a network, try these solutions:

- Make sure your product is turned on and connected to your network. Verify the connection using your product control panel.

- Check if your network name (SSID) contains non-ASCII characters. Your product cannot display non-ASCII characters.
- Print a network connection report and check the codes and messages on the report to help determine the cause of the problem.
- Make sure your product is not connected to a guest network.
- If necessary, reinstall your product software and try running EpsonNet Setup again:
  1. Reset your product's network settings to their factory defaults.
  2. **Windows only:** Uninstall your product software.
  3. Restart your router following the instructions in your router documentation.

**Note:** If you are reading these instructions online, you will lose your Internet connection when you restart your router, so note the next step before restarting it.

4. Download your product software from the Epson website using the instructions on the *Start Here* sheet.
- If you have replaced your router, reinstall your product software to connect to the new router.

**Note:** If you are using a 5 GHz wireless router, set the router to operate in dual band (2.4 GHz and 5 GHz) mode. If your router uses a single network name (SSID) for both the 2.4 GHz and 5 GHz band, give each band its own network name (SSID) instead, such as Home Network 2.4 GHz and Home Network 5 GHz. See your router documentation or contact your internet service provider for instructions.

- Check to see if your wireless router or access point has an enabled Privacy Separator function that is preventing detection of your device over the network. See your router or access point documentation for instructions on disabling the Privacy Separator function.

**Parent topic:** [Solving Network Problems](#)

**Related concepts**

[Uninstall Your Product Software](#)

**Related tasks**

[Printing a Network Connection Report](#)

**Related topics**

[Wi-Fi or Wired Networking](#)

## Product Does Not Appear in Mac Printer Window

If your product does not appear in the Mac printer window, try these solutions:

- Turn your product off, wait 30 seconds, then turn it back on again.
- If you are connecting the product via Wi-Fi Protected Setup (WPS) and the Wi-Fi icon on your product's LCD screen is not lit, make sure you select one of the WPS options from the product control panel within 2 minutes of pressing the WPS button on your router.
- If you are connecting the product wirelessly via EpsonNet Setup and the Wi-Fi icon does not appear lit on your LCD screen, make sure your product software was installed correctly. If necessary, reinstall your software.

**Note:** If you are using a 5 GHz wireless router, set the router to operate in dual band (2.4 GHz and 5 GHz) mode. If your router uses a single network name (SSID) for both the 2.4 GHz and 5 GHz band, give each band its own network name (SSID) instead, such as Home Network 2.4 GHz and Home Network 5 GHz. See your router documentation or contact your internet service provider for instructions.

**Parent topic:** [Solving Network Problems](#)

### Related concepts

[Uninstall Your Product Software](#)

## Wireless Network Connection is Unstable on a Mac

If you connected a device to a USB 3.0 port on your Mac, you may experience wireless network interference between your product and your Mac.

If you cannot connect to your product over the wireless network or the connection becomes unstable, move the device connected to your Mac USB 3.0 port further away from your Mac.

**Parent topic:** [Solving Network Problems](#)

## Wired Network Connection Becomes Unstable

When you connect the product to a wired network using a router or access point that supports IEEE 802.3az (Energy Efficient Ethernet), the connection may become unstable, you may be unable to connect to the product, and the communication speed may become slow. If you experience any of these issues, follow the steps below to disable IEEE 802.3az and then connect your product again.

1. Disconnect the Ethernet cables connected to the computer and your product.
2. Disable IEEE 802.3az for the computer's network adapter if it is enabled (check your operating system's Ethernet connection settings).

3. Connect the computer and your product directly with an Ethernet cable.
4. Print a network connection report from your product.
5. On the computer, open a web browser and enter your product's IP address from the network connection report.
6. Select **Advanced Settings > Network Settings > Wired LAN**.
7. Select **OFF** for IEEE 802.3az. and click **Next**.
8. Click **OK** and remove the Ethernet cable connecting the computer and your product.
9. If you disabled IEEE 802.3az for your computer's network adapter, enable it.
10. Reconnect the Ethernet cables from the router or access point to your computer and product.

If problems still occur, other devices on the network may be causing them.

**Parent topic:** [Solving Network Problems](#)

#### **Related tasks**

[Printing a Network Connection Report](#)

## **Cannot Print Over a Network**

If you cannot print over a network, try these solutions:

- Make sure that your product is turned on.
- Make sure you install your product's network software as described in your product documentation.
- Print a network status sheet and verify that the network settings are correct. If the network status is **Disconnected**, check any cable connections and turn your product off and then on again.
- Print a network connection report and check the codes and messages on the report to help determine the cause of the problem.
- If you are using TCP/IP, make sure the product's IP address is set correctly for your network. If your network does not assign IP addresses using DHCP, set the IP address manually.
- Make sure your computer and product are both using the same wireless network.
- If network printing is slow, print a network status sheet and check the signal strength. If it is poor, place your product closer to your router or access point. Avoid placing your product near a microwave oven, cordless phone, or large metal object, such as a filing cabinet.

**Note:** If you are using a 5 GHz wireless router, set the router to operate in dual band (2.4 GHz and 5 GHz) mode. If your router uses a single network name (SSID) for both the 2.4 GHz and 5 GHz band, give each band its own network name (SSID) instead, such as Home Network 2.4 GHz and Home

Network 5 GHz. See your router documentation or contact your internet service provider for instructions.

- Try restarting your router following the instructions in your router documentation.

**Note:** If you are reading these instructions online, you will lose your Internet connection when you restart your router.

- Check to see if your wireless router or access point has an enabled Privacy Separator function that is preventing printing from a device over the network. See your router or access point documentation for instructions on disabling the Privacy Separator function.
- If you are connecting the product wirelessly via EpsonNet Setup and the Wi-Fi connection icon is not lit or does not appear on the product's LCD screen, make sure your product software was installed correctly. If necessary, reinstall your software.

**Parent topic:** [Solving Network Problems](#)

**Related concepts**

[Uninstall Your Product Software](#)

**Related tasks**

[Printing a Network Status Sheet](#)

[Printing a Network Connection Report](#)

**Related topics**

[Wi-Fi or Wired Networking](#)

## Cannot Scan Over a Network

If you cannot scan over a network, try these solutions:

- Make sure the computer and product are connected to the same network (or network segment/VLAN).
- Move the product and computer or smart device closer to the router or access point.
- If you cannot scan from your product control panel, make sure you restarted your computer after installing the product software. Make sure the Event Manager program is not being blocked by your firewall or security software.

**Note:** If you are using a 5 GHz wireless router, set the router to operate in dual band (2.4 GHz and 5 GHz) mode. If your router uses a single network name (SSID) for both the 2.4 GHz and 5 GHz band, give each band its own network name (SSID) instead, such as Home Network 2.4 GHz and Home

Network 5 GHz. See your router documentation or contact your internet service provider for instructions.

- Check the scanning setting assigned in Epson Event Manager.
- If network communication was interrupted while starting Epson Scan 2, exit Epson Scan 2, wait a few seconds, and restart it. If Epson Scan 2 cannot restart, turn off your product, turn it back on, and try restarting Epson Scan 2 again.
- If you are scanning a large original at a high resolution, a network communication error may occur. Try scanning again at a lower resolution.
- Check the network connection setting in the Epson Scan 2 Utility.
- Check the scanner setting and reset the connection if necessary using Epson Scan 2 Utility:

**Windows 10:** Click  and select **EPSON > Epson Scan 2 Utility**. Make sure your product is selected. If necessary, select the **Other** tab and click **Reset**.

**Windows 8.x:** Navigate to the **Apps** screen, select **EPSON**, and select **Epson Scan 2 Utility**. Make sure your product is selected. If necessary, select the **Other** tab and click **Reset**.

**Windows (other versions):** Click  or **Start > All Programs** or **Programs > EPSON > Epson Scan 2 > Epson Scan 2 Utility**. Make sure your product is selected. If necessary, select the **Other** tab and click **Reset**.

**Mac:** Open the **Applications** folder, click **Epson Software**, and click **Epson Scan 2 Utility**. Make sure your product is selected. If necessary, select the **Other** tab and click **Reset**.

- You may need to disable the firewall and any anti-virus software on your wireless router or access point.
- If you see the message "Network product is not available: currently being used by user", there may be a communication error between the product and computer. Restart the product.
- If the Firewall function is active, the product may not be discovered by the Epson Scan 2 Utility. Open the Epson Scan 2 Utility, enter the IP address for your product, and click **Add**.
- If the product and computer cannot communicate and are connected to the same network (or network segment/VLAN), the privacy separator on your router must be disabled. Follow the instructions in your router documentation to disable the privacy separator.

**Parent topic:** [Solving Network Problems](#)

## Solving Copying Problems

Check these solutions if you have problems copying with your product.



[Product Makes Noise, But Nothing Copies](#)  
[Product Makes Noise When It Sits for a While](#)

**Parent topic:** [Solving Problems](#)

## **Product Makes Noise, But Nothing Copies**

If your product makes a noise, but nothing copies, try these solutions:

- Run a nozzle check to see if any of the print head nozzles are clogged. Then clean the print head, if necessary.
- If the nozzle check page does not print, but the product's power is on, make sure your product software is installed correctly.
- Make sure your product is level (not tilted).

**Parent topic:** [Solving Copying Problems](#)

**Related concepts**

[Print Head Maintenance](#)

## **Product Makes Noise When It Sits for a While**

Your product is performing routine maintenance. This is normal.

**Parent topic:** [Solving Copying Problems](#)

## **Solving Paper Problems**

Check these sections if you have problems using paper with your product.

[Paper Feeding Problems](#)

[Paper Jam Problems in the Paper Cassettes](#)

[Paper Jam Problems Inside the Product](#)

[Paper Jam Problems in the Rear Cover](#)

[Rear Paper Support Problems](#)

[Paper Ejection Problems](#)

**Parent topic:** [Solving Problems](#)

## Paper Feeding Problems

If you have problems feeding paper, try these solutions:

- If paper does not feed for printing, remove it from the rear paper feeder or cassette. Reload it, then adjust the edge guides. Make sure the paper stack is not above the tab on the edge guides inside the cassette. Make sure to load only one sheet at a time in the rear paper feed slot.
- Place the product on a flat surface and operate it in the recommended environmental conditions.
- Be sure to insert the paper cassette all the way into your product.
- If multiple pages feed at once, remove the paper, fan the edges to separate the sheets, and reload it.
- Do not load more than the recommended number of sheets.
- Make sure your paper meets the specifications for your product.
- If paper jams when you print on both sides of the paper, try loading fewer sheets.
- If paper is ejected from the rear paper feed slot without being printed, first start your print job, then load the sheet of paper.
- Make sure the paper size and paper type settings are correct for the paper source.
- Run the paper guide cleaning utility to clean the paper path.
- Clean the roller inside the printer to remove any dust on the paper path.
- For best results, follow these guidelines:
  - Use new, smooth, high-quality paper that is not curled, creased, old, too thin, or too thick.
  - Load paper in the cassette printable side down.
  - Do not load binder paper with holes in the cassette.
  - Follow any special loading instructions that came with the paper.

**Parent topic:** [Solving Paper Problems](#)

### Related references

[Paper Jam Problems in the Paper Cassettes](#)

[Paper Jam Problems Inside the Product](#)

[Paper Jam Problems in the Rear Cover](#)

[Paper Loading Capacity](#)

[Paper Specifications](#)

### Related tasks

[Cleaning the Paper Guide](#)

## Paper Jam Problems in the Paper Cassettes

If you see a message that paper has jammed in a paper cassette, follow the steps here or on the LCD screen to clear the jam.

1. Cancel the print job, if necessary.
2. Remove both paper cassettes.

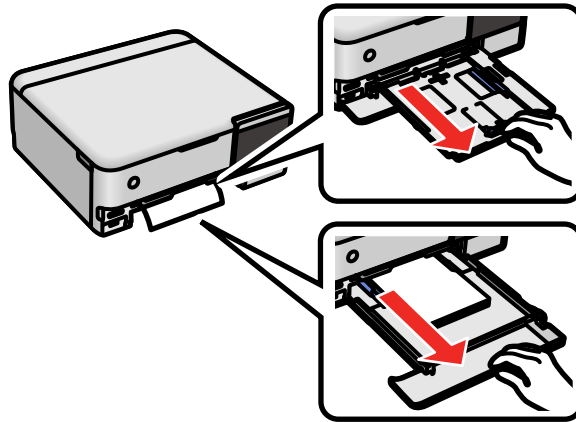

3. Carefully remove any jammed paper.

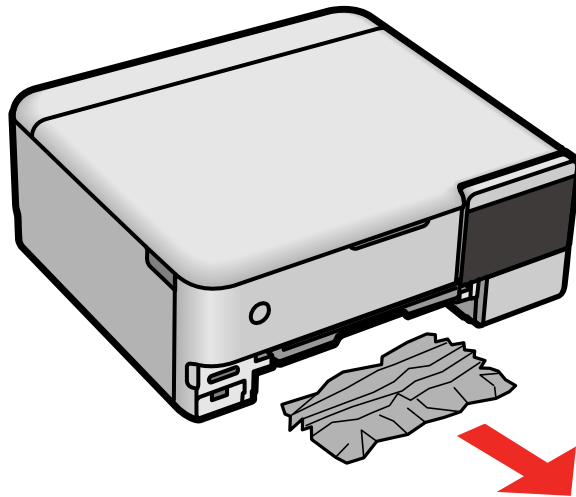

4. Make sure the paper is loaded under the edge guides.
5. Keep the cassettes flat as you insert them.
6. Follow the prompts on the LCD screen to clear any error messages. If you still see a paper jam message, check the other paper jam solutions.

**Parent topic:** [Solving Paper Problems](#)

**Related references**

[Paper Jam Problems Inside the Product](#)

[Paper Jam Problems in the Rear Cover](#)

**Related tasks**

[Cancelling Printing From the LCD Screen](#)

## Paper Jam Problems Inside the Product

If you see a message that paper has jammed inside the product, follow the steps here or on the LCD screen to clear the jam.

1. Cancel the print job, if necessary.
2. Lift the scanner unit until it locks into place.

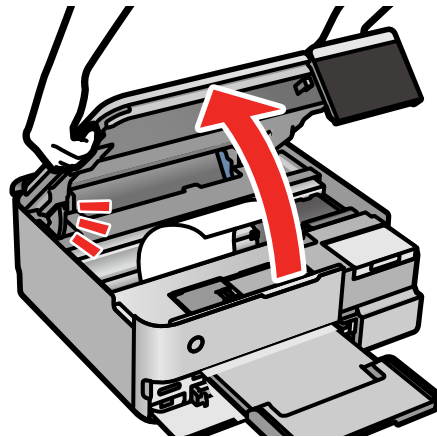

3. Remove any jammed paper inside.

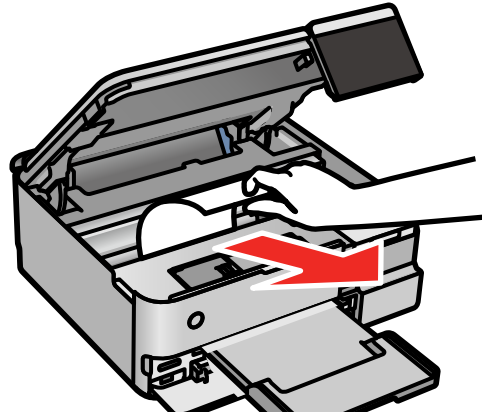

**Caution:** Do not touch the flat white cable, the translucent film, or the metal print head rail inside your product.

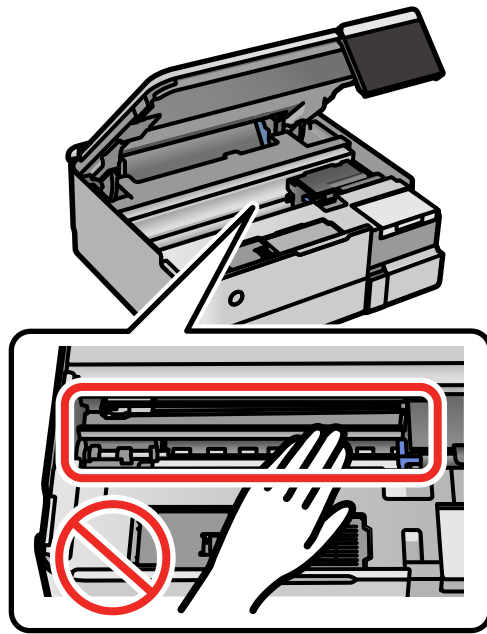

4. Close the scanner unit.

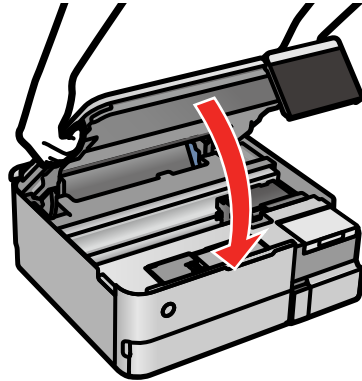

5. Follow the prompts on the LCD screen to clear any error messages. If you still see a paper jam message, check the other paper jam solutions.

**Parent topic:** [Solving Paper Problems](#)

**Related references**

[Paper Jam Problems in the Paper Cassettes](#)

[Paper Jam Problems in the Rear Cover](#)

[Paper Specifications](#)

[Paper Feeding Problems](#)

[Paper Ejection Problems](#)

**Related tasks**

[Cancelling Printing From the LCD Screen](#)

**Related topics**

[Loading Paper](#)

## Paper Jam Problems in the Rear Cover

If you see a message that paper has jammed in the rear cover, follow the steps here or on the LCD screen to clear the jam.

1. Cancel the print job, if necessary.

2. Extend the rear paper support and tilt it back.

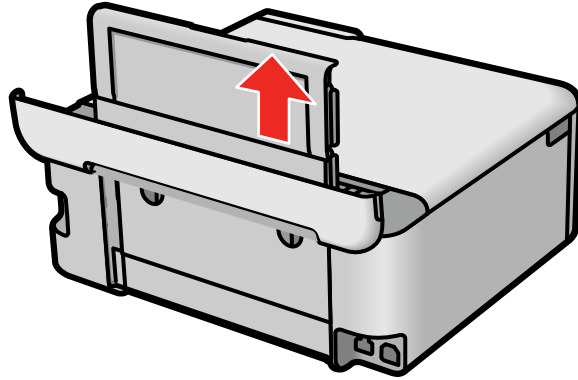

3. Press the buttons to release the rear cover and remove it from your product.

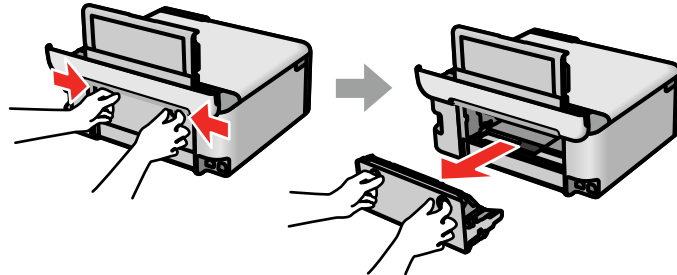

4. Carefully remove any jammed paper from inside the product.

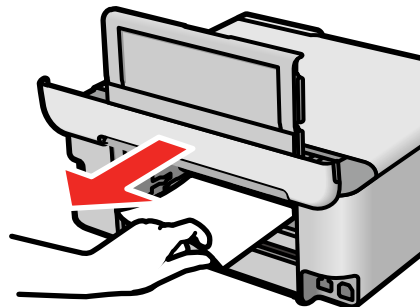

5. Remove any jammed paper from the rear cover.

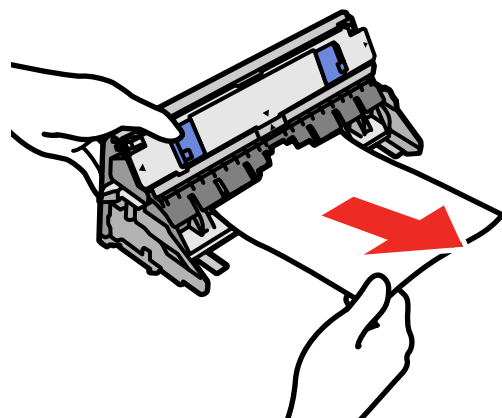



**Caution:** Do not touch the parts shown below; otherwise, they may be damaged.

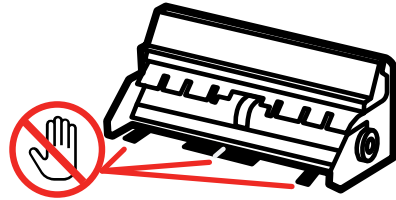

6. Reinsert the rear cover into your product.

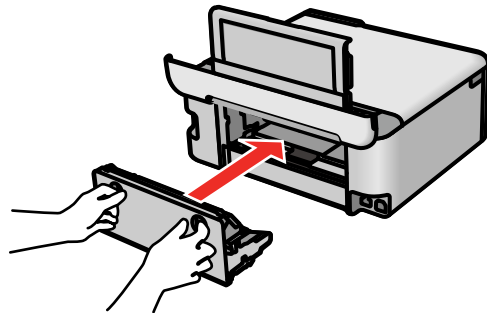

7. Follow the prompts on the LCD screen to clear any error messages. If you still see a paper jam message, check the other paper jam solutions.

**Parent topic:** [Solving Paper Problems](#)

**Related references**

[Paper Jam Problems in the Paper Cassettes](#)

[Paper Jam Problems Inside the Product](#)

**Related tasks**

[Cancelling Printing From the LCD Screen](#)

## Rear Paper Support Problems

If the rear paper support for the rear paper feeder comes off, you can reinsert it as shown.

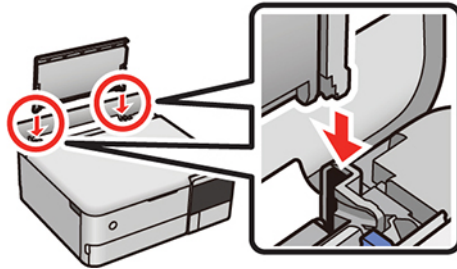

Parent topic: [Solving Paper Problems](#)

## Paper Ejection Problems

If you have problems with paper ejecting properly, try these solutions:

- If paper does not eject fully, you may have set the wrong paper size. Cancel printing to eject the paper. Select the correct paper size when you reprint.
- If paper is wrinkled when it ejects, it may be damp or too thin. Load new paper and be sure to select the correct paper type setting when you reprint.

Parent topic: [Solving Paper Problems](#)

### Related references

[Paper Specifications](#)

[Paper or Media Type Settings - Printing Software](#)

[Paper or Media Type Settings - Control Panel](#)

### Related tasks

[Cancelling Printing From the LCD Screen](#)

### Related topics

[Loading Paper](#)

## Solving Problems Printing from a Computer

Check these sections if you have problems while printing from your computer.

**Note:** When printing using AirPrint, the available print settings are different from those covered in this manual. See the Apple website for details.

[Nothing Prints](#)

[Product Icon Does Not Appear in Windows Taskbar](#)

[Printing is Slow](#)

**Parent topic:** [Solving Problems](#)

## Nothing Prints

If you have sent a print job and nothing prints, try these solutions:

- Make sure your product is turned on and connected to your computer.
- Make sure any interface cables are connected securely at both ends.
- If you connected your product to a USB hub, make sure it is a first-tier hub. If it still does not print, connect your product directly to your computer instead of the hub.
- Make sure the printer status is not offline or pending.
- Run a product check to see if a test page prints. If the test page prints, check to see if your product software is installed correctly.
- Make sure your system meets the requirements for your operating system. If you are printing a high-resolution image, you may need more than the minimum requirements. Print the image at a lower resolution or if necessary, increase your system's memory.
- In Windows, make sure your product is selected as the default printer and the printer port setting matches the printer connection port.
- In Windows, delete all jobs from the Windows Spooler. Click **Print Queue** on the Maintenance tab in the printer settings window, and cancel any stalled print jobs.
- On a Mac, make sure the printer is added to the printer list and the printer is not paused.
- Make sure your product is selected as the printer in your printing program.

**Parent topic:** [Solving Problems Printing from a Computer](#)

### Related references

[Product Status Messages](#)





### Related tasks

[Running a Product Check](#)

## Product Icon Does Not Appear in Windows Taskbar

If you do not see your product icon in the Windows taskbar, first try restarting your computer. If that does not work, try this solution:

1. Do one of the following:

- **Windows 10:** Click  and select  (Settings) > **Devices > Printers & scanners**. Select your product name and select **Manage > Printing preferences**.
- **Windows 8.x:** Navigate to the **Apps** screen and select **Control Panel > Hardware and Sound > Devices and Printers**. Right-click your product name, select **Printing Preferences**, and select your product name again if necessary.
- **Windows 7:** Click  and select **Devices and Printers**. Right-click your product name, select **Printing Preferences**, and select your product name again if necessary.
- **Windows Vista:** Click , select **Control Panel**, and click **Printer** under **Hardware and Sound**. Right-click your product name, select **Printing Preferences**, and select your product name again if necessary.

2. Click the **Maintenance** tab.

3. Click the **Extended Settings** button.

4. Select **Enable EPSON Status Monitor 3** and click **OK**.

5. Click the **Monitoring Preferences** button.

6. Click the checkbox for the option that adds the shortcut icon to the taskbar.

7. Click **OK** to close the open program windows.

**Parent topic:** [Solving Problems Printing from a Computer](#)

## Printing is Slow

If printing becomes slow, try these solutions:

- Make sure your system meets the requirements for your operating system. If you are printing a high-resolution image, you may need more than the minimum requirements. If necessary, increase your system's memory.
- If you are using Windows 7, close the **Devices and Printers** window before you print.
- On a Mac, make sure you download and install the Epson printer driver.
- Make sure **Quiet Mode** is turned off.

- Clear space on your hard drive or run a defragmentation utility to free up existing space.
- Close any programs you are not using when you print.
- If your product is connected to a USB hub, connect it directly to your computer instead.
- If printing becomes slower after printing continuously for a long time, the product may have automatically slowed down to protect the print mechanism from overheating or becoming damaged. Let the product rest with the power on for 30 minutes, then try printing again.
- If you are printing over a wireless network, factors such as interference, network traffic, or weak signal strength may affect your printing speed.
- If you are printing photos on plain paper, print speed may be reduced to maintain image quality.

For the fastest printing, select the following settings in your product software:

- Make sure the paper type setting matches the type of paper you loaded.
- Turn on any high speed settings in your product software.
- Select a lower print quality setting.
- Make sure the ink drying time has not been increased for double-sided printing.
- **Windows:** Click the **Maintenance** or **Utility** tab, select **Extended Settings** or **Speed and Progress**, and select the following settings:
  - **Always Spool RAW Datatype**
  - **Page Rendering Mode**
  - **Print as Bitmap**
- **Windows:** Select **Printing preferences**, click the **More Options** tab, and make sure the **Bidirectional printing** setting is enabled.
- **Mac:** Select **System Preferences**, select **Printers & Scanners**, and select your product. Select **Options & Supplies**, select **Options** (or **Driver**), and enable the **Bidirectional printing** setting.
- Enable the bidirectional setting on the product control panel.

If printing is still slow and you are using Windows 7 or Windows Vista, try the following:

1. Click  and select **Computer** or **My Computer**. Double-click the **C:** drive and open these folders: **ProgramData > EPSON > PRINTER**.

**Note:** If you do not see the ProgramData folder, open the **Organize** menu and select **Folder and search options**. In the window that appears, click the **View** tab, select **Show hidden files, folders, and drives** in the Advanced settings list, and click **OK**.

2. Right-click the **EPAUDF01.AUD** file and select **Delete**.
3. Restart your computer and try printing again.

**Parent topic:** [Solving Problems Printing from a Computer](#)

**Related references**

[Paper or Media Type Settings - Printing Software](#)

[Windows System Requirements](#)

[Mac System Requirements](#)

**Related tasks**

[Selecting Basic Print Settings - Windows](#)

[Selecting Extended Settings - Windows](#)

[Selecting Basic Print Settings - Mac](#)

[Selecting Printing Preferences - Mac](#)

## Solving Page Layout and Content Problems

Check these sections if you have problems with the layout or content of your printed pages.

**Note:** When printing using AirPrint, the available print settings are different from those covered in this manual. See the Apple website for details.

[Inverted Image](#)

[Too Many Copies Print](#)

[Blank Pages Print](#)

[Incorrect Margins on Printout](#)

[Border Appears on Borderless Prints](#)

[Incorrect Characters Print](#)

[Incorrect Image Size or Position](#)

[Slanted Printout](#)

**Parent topic:** [Solving Problems](#)

### Inverted Image

If your printed image is inverted unexpectedly, try these solutions:

- Turn off any mirror or inversion settings in your printing application.

- Turn off the **Mirror Image**, **Flip horizontally**, or **Reverse page orientation** settings in your printer software. (This option has different names, depending on your operating system version.)

**Parent topic:** [Solving Page Layout and Content Problems](#)

**Related tasks**

[Selecting Additional Layout and Print Options - Windows](#)

[Selecting Basic Print Settings - Mac](#)

[Selecting Print Layout Options - Mac](#)

## Too Many Copies Print

Make sure that the **Copies** setting in your printing program or printer software is not set for multiple copies.

**Parent topic:** [Solving Page Layout and Content Problems](#)

**Related tasks**

[Selecting Basic Print Settings - Windows](#)

[Selecting Basic Print Settings - Mac](#)

## Blank Pages Print

If blank pages print unexpectedly, try these solutions:

- Make sure you selected the correct paper size settings in your printing program and printer software.
- If a blank page exists in a document you are printing and you want to skip printing it, select the **Skip Blank Page** setting in your printer software, if available.
- Run a print head nozzle check to see if any of the nozzles are clogged. Then clean the print head, if necessary.
- Make sure your product is selected as the printer in your printing program.
- You may need to refill the ink. Visually check the ink levels.

**Parent topic:** [Solving Page Layout and Content Problems](#)

**Related concepts**

[Print Head Maintenance](#)

**Related tasks**

[Checking the Ink Levels on Your Product](#)

[Selecting Basic Print Settings - Windows](#)

[Selecting Basic Print Settings - Mac](#)

[Selecting Extended Settings - Windows](#)  
[Selecting Printing Preferences - Mac](#)  
[Printing Your Document or Photo - Windows](#)  
[Printing Your Document or Photo - Mac](#)

## Incorrect Margins on Printout

If your printed page has incorrect margins, try these solutions:

- Make sure you selected the correct paper size settings in your printing program and printer software.
- Make sure you selected the correct margins for your paper size in your printing program.
- Make sure your paper is positioned correctly for feeding into the product.
- When placing originals on the scanner glass, align the corner of the original with the corner indicated by the arrow. If the edges of the copy are cropped, move the original slightly away from the corner.
- Clean the scanner glass and the document cover. If there is dust or stains on the glass, the copy area may extend to include the dust or stains.
- Load paper in the correct direction and slide the edge guides against the edges of the paper.

You can use the preview option in your printer software to check your margins before you print.

**Parent topic:** [Solving Page Layout and Content Problems](#)

### Related tasks

[Selecting Basic Print Settings - Windows](#)  
[Selecting Basic Print Settings - Mac](#)  
[Selecting Page Setup Settings - Mac](#)

### Related topics

[Loading Paper](#)  
[Placing Originals on the Product](#)

## Border Appears on Borderless Prints

If you see a border on borderless prints, try these solutions:

- Make sure you are printing on a compatible borderless paper type and size.

**Note:** For custom paper sizes, make sure you select a supported borderless page width.

- **Windows:** Make sure you selected the **Borderless** setting in your printer software.



- **Mac:** Make sure you selected the **Borderless** checkbox or a paper size with a **Borderless** option in your printer software.
- Adjust the **Expansion** setting to adjust the amount of image expansion on the edges of borderless prints.
- Make sure the image size and the paper size are set correctly; if the image is small, the enlargement may not be enough to cover the paper.

**Parent topic:** [Solving Page Layout and Content Problems](#)

#### **Related references**

[Borderless Paper Type Compatibility](#)

#### **Related tasks**

[Selecting Basic Print Settings - Windows](#)

[Selecting Extended Settings - Windows](#)

[Selecting Basic Print Settings - Mac](#)

[Selecting Page Setup Settings - Mac](#)

[Selecting Print Layout Options - Mac](#)

[Selecting Printing Preferences - Mac](#)

## **Incorrect Characters Print**

If incorrect characters appear in your prints, try these solutions before reprinting:

- Make sure any cables are securely connected at both ends.
- In Windows, delete all jobs from the Windows Spooler. Click **Print Queue** on the Maintenance tab in the printer settings window, and cancel any stalled print jobs.
- If your product is connected to a USB hub, connect it directly to your computer instead.
- If your computer entered sleep mode the last time you printed, the next print job after your computer exits sleep mode may contain garbled characters. Print your document again.

**Parent topic:** [Solving Page Layout and Content Problems](#)

## **Incorrect Image Size or Position**

If your printed image is the wrong size or in the wrong position, try these solutions:

- Make sure you selected the correct paper size and layout settings in your printing program and printer software.
- Make sure you selected the correct paper size on the control panel.

- Make sure your paper is positioned correctly for feeding into the printer.
- Slide the edge guides against the edges of the paper.
- Clean the scanner glass and document cover.
- If the edges of a copy are cropped, slightly move the original away from the edges of the scanner glass.
- Make sure you selected the correct margins for your paper size in your printing program.
- If the image is slightly enlarged and cropped during borderless printing, change the **Expansion** setting.

You can use the preview option in your printer software to check your margins before you print.

**Parent topic:** [Solving Page Layout and Content Problems](#)

**Related tasks**

[Selecting Basic Print Settings - Windows](#)

[Selecting Basic Print Settings - Mac](#)

[Selecting Page Setup Settings - Mac](#)

[Cleaning Your Product](#)

**Related topics**

[Placing Originals on the Product](#)

[Loading Paper](#)

## Slanted Printout

If your printouts are slanted, try these solutions:

- Make sure the paper is loaded in the correct direction.
- Make sure your paper meets the specifications for your product.
- Do not load more than the recommended number of sheets.
- Slide the edge guides against the edges of the paper.
- Make sure the paper type setting matches the type of paper you loaded.
- Select a higher print quality setting in your printer software.
- Turn off any high speed settings in your product software.
- Align the print head.
- Make sure the product is not printing while tilted or at an angle.

**Parent topic:** [Solving Page Layout and Content Problems](#)

**Related tasks**

[Selecting Basic Print Settings - Windows](#)

[Selecting Basic Print Settings - Mac](#)

[Aligning the Print Head Using the Product Control Panel](#)

**Related topics**

[Loading Paper](#)

## Solving Print Quality Problems

Check these sections if your printouts have problems with print quality, but your image looks fine on your computer screen.

**Note:** When printing using AirPrint, the available print settings are different from those covered in this manual. See the Apple website for details.

[White or Dark Lines in Printout](#)

[Blurry or Smearred Printout](#)

[Faint Printout or Printout Has Gaps](#)

[Grainy Printout](#)

[Incorrect Colors](#)

**Parent topic:** [Solving Problems](#)

### White or Dark Lines in Printout

If you notice white or dark lines in your prints (also called banding), try these solutions before you reprint:

- Run a nozzle check to see if any of the print head nozzles are clogged. Then clean the print head, if necessary.
- Make sure the paper type setting matches the type of paper you loaded.
- Make sure you loaded the printable side of the paper correctly for your product.
- Turn off any high speed settings in your product software.
- Align the print head.
- Adjust the print quality in the product software.

- If you continue to see horizontal or vertical bands or streaks in your printouts after cleaning and aligning the print head, you can finely tune the horizontal or vertical alignment in the Maintenance menu.
- You may need to refill the ink. Visually check the ink levels.
- If you have not used the product for a long time, run the Power Cleaning utility.

**Note:** Power Cleaning consumes a lot of ink, so run this utility only if you cannot improve print quality by cleaning the print head.

**Parent topic:** [Solving Print Quality Problems](#)

**Related concepts**

[Print Head Maintenance](#)

[Power Cleaning](#)

**Related references**

[Paper or Media Type Settings - Printing Software](#)

[Paper or Media Type Settings - Control Panel](#)

**Related tasks**

[Checking the Ink Levels on Your Product](#)

[Aligning the Print Head Using the Product Control Panel](#)

[Selecting Additional Layout and Print Options - Windows](#)

[Selecting Printing Preferences - Mac](#)

[Selecting Basic Print Settings - Windows](#)

[Selecting Basic Print Settings - Mac](#)

[Refilling the Ink Tanks](#)

**Related topics**

[Loading Paper](#)

## **Blurry or Smearred Printout**

If your printouts are blurry or smearred, try these solutions:

- Make sure your paper is not damp, curled, old, or loaded incorrectly in your product.
- Slide the edge guides to the edges of the paper.
- Use a support sheet with special paper, or load special paper one sheet at a time.

- Place a piece of black paper on the back of the original and copy it again.
- Make sure your paper meets the specifications for your product.
- Use Epson papers to ensure proper saturation and absorption of genuine Epson inks.
- Make sure the paper type setting in your product software matches the type of paper you loaded.
- Make sure you loaded the printable side of the paper correctly for your product.
- If you are printing on thick paper or envelopes, turn on the **Thick Paper** setting from the control panel or select **Thick Paper and Envelopes** in the Extended Settings of the printer software. (Turning this setting on will decrease print speed.) You can also try selecting **Short Grain Paper** from the control panel.
- If you are printing on thick paper or envelopes, make sure you select the appropriate settings.
- When manually printing 2-sided, make sure the ink is completely dry before loading the paper.
- Remove each sheet from the output tray as it is printed.
- Avoid handling printouts on glossy paper right after printing to allow the ink to set.
- Dry printouts completely before filing or displaying them. When drying printouts, avoid direct sunlight, do not use a dryer, and do not touch the printed side of the paper.
- Turn off any high speed settings in your product software.
- If you print on both sides of a sheet of paper, smudges may appear on the reverse side of heavily saturated or dark images. If one side of a sheet will contain a lighter image or text, print that side first. Make sure the ink has dried before reloading the paper to print on the other side. Adjust the density and/or ink drying time settings.
- Lower the copy density setting on the product control panel.
- The ink levels may be low and you may need to refill the ink. Visually check the ink levels.
- Run a nozzle check to see if any of the print head nozzles are clogged. Then clean the print head, if necessary.
- Align the print head.
- Adjust the print quality in the product software.
- Clean the paper path.
- Do not press too hard on the original or the document cover when you are scanning originals on the scanner glass.
- Clean the scanner glass.
- If you have not used the product for a long time, run the Power Cleaning utility.

**Note:** Power Cleaning consumes a lot of ink, so run this utility only if you cannot improve print quality by cleaning the print head.

**Note:** Your product will not operate properly while tilted at an angle. Place it on a flat, stable surface that extends beyond the base of the product in all directions.

**Parent topic:** [Solving Print Quality Problems](#)

**Related concepts**

[Print Head Maintenance](#)

[Power Cleaning](#)

**Related references**

[Paper Specifications](#)

**Related tasks**

[Cleaning the Paper Guide](#)

[Aligning the Print Head Using the Product Control Panel](#)

[Checking the Ink Levels on Your Product](#)

[Selecting Basic Print Settings - Windows](#)

[Selecting Basic Print Settings - Mac](#)

[Selecting Additional Layout and Print Options - Windows](#)

[Selecting Printing Preferences - Mac](#)

[Selecting Double-sided Printing Settings - Windows](#)

[Selecting Double-sided Printing Settings - Mac](#)

[Cleaning the Paper Path](#)

[Cleaning Your Product](#)

**Related topics**

[Loading Paper](#)

## Faint Printout or Printout Has Gaps

If your printouts are faint or have gaps, try these solutions:

- Run a nozzle check to see if any of the print head nozzles are clogged. Then clean the print head, if necessary.
- The ink levels may be low. Visually check the ink levels.
- Make sure the paper type setting matches the type of paper you loaded.

- Make sure your paper is not damp, curled, old, or loaded incorrectly in your product.
- Align the print head.
- Adjust the print quality in the product software.
- Clean the paper path.
- If you have not used the product for a long time, run the Power Cleaning utility.

**Note:** Power Cleaning consumes a lot of ink, so run this utility only if you cannot improve print quality by cleaning the print head.

**Parent topic:** [Solving Print Quality Problems](#)

**Related concepts**

[Power Cleaning](#)

[Print Head Maintenance](#)

**Related tasks**

[Checking the Ink Levels on Your Product](#)

[Aligning the Print Head Using the Product Control Panel](#)

[Cleaning the Paper Path](#)

[Cleaning the Paper Guide](#)

[Refilling the Ink Tanks](#)

**Related topics**

[Loading Paper](#)

## Grainy Printout

If your printouts are grainy, try these solutions:

- Make sure you loaded the printable side of the paper correctly for your product.
- Select a higher print quality setting and turn off any high speed settings in your product software.
- Run a nozzle check to see if any of the print head nozzles are clogged. Then clean the print head, if necessary.
- Align the print head.
- Adjust the print quality in the product software.
- You may need to increase the image resolution or print a smaller size; see your software documentation.

**Note:** Images from the Internet may be low resolution and not result in a high quality printout.

- If you enlarged the image size in an image-editing program, you need to increase the image resolution setting to retain a high image quality. Increase the image resolution by the same amount you increase the image size. For example, if the image resolution is 300 dpi (dots per inch) and you will double the image size for printing, change the resolution setting to 600 dpi.

**Note:** Higher resolution settings result in larger file sizes, which take longer to process and print. Consider the limitations of your computer system when selecting a resolution, and select the lowest possible resolution that produces acceptable quality to keep file sizes manageable.

**Parent topic:** [Solving Print Quality Problems](#)

**Related concepts**

[Print Head Maintenance](#)

**Related references**

[Paper or Media Type Settings - Printing Software](#)

**Related tasks**

[Aligning the Print Head Using the Product Control Panel](#)

[Selecting Basic Print Settings - Windows](#)

[Selecting Basic Print Settings - Mac](#)

[Refilling the Ink Tanks](#)

**Related topics**

[Loading Paper](#)

## Incorrect Colors

If your printouts have incorrect colors, try these solutions:

- Make sure the paper type setting matches the paper you loaded.
- Make sure the **Black/Grayscale** or **Grayscale** setting is not selected in your printer software.
- Select **EPSON Standard** as the **Color Mode** (Windows) or **Mode** (Mac) setting in the printer software.
- Run a nozzle check to see if any of the print head nozzles are clogged. Then clean the print head, if necessary.
- The ink levels may be low and you may need to refill the ink. Visually check the ink levels.



- After you print, the colors in your printout need time to set as the ink dries. During this time, the colors may look different than you expect. To speed up drying time, do not stack your printouts on top of each other.
- Your printed colors can never exactly match your on-screen colors. However, you can use a color management system to get as close as possible. Try using the color management options in your printer software.
- Try selecting a different **Color Management** setting on the More Options tab of the printer software, and changing the **Scene Correction** setting to something other than **Auto Correct**.
- For best results, use genuine Epson paper.
- If you have not used the product for a long time, run the Power Cleaning utility.

**Note:** Power Cleaning consumes a lot of ink, so run this utility only if you cannot improve print quality by cleaning the print head.

- On the product control panel, change the **Fix Photo** setting from **Auto** to another option, or select **Enhance Off**.

**Parent topic:** [Solving Print Quality Problems](#)

**Related concepts**

[Power Cleaning](#)

[Print Head Maintenance](#)

**Related references**

[Photo Adjustments - Camera](#)

**Related tasks**

[Checking the Ink Levels on Your Product](#)

[Selecting Basic Print Settings - Windows](#)

[Selecting Basic Print Settings - Mac](#)

[Selecting Additional Layout and Print Options - Windows](#)

[Managing Color - Mac](#)

[Refilling the Ink Tanks](#)

## Solving Scanning Problems

Check these solutions if you have problems scanning with your product.

[Scanning Software Does Not Operate Correctly](#)

[Cannot Start Epson Scan 2](#)  
[Scanning is Slow](#)  
[Cannot Send Scans to a Cloud Service](#)

**Parent topic:** [Solving Problems](#)

## Scanning Software Does Not Operate Correctly

If your scanning software does not operate correctly, try these solutions:

- Make sure your computer has adequate memory and meets the system requirements for your operating system.
- Make sure your computer is not running in a power-saving mode, such as sleep or standby. If so, wake your system and restart your scanning software.
- If you upgraded your operating system but did not reinstall your scanning software, try reinstalling it.
- In Windows, make sure your product is listed as a valid device in the **Scanners and Cameras** control panel.
- Try scanning at a lower resolution or increase the free space on the computer's hard disk. Scanning stops if the total data size reaches the limit.

**Parent topic:** [Solving Scanning Problems](#)

### Related concepts

[Uninstall Your Product Software](#)

### Related references

[Windows System Requirements](#)

[Mac System Requirements](#)

## Cannot Start Epson Scan 2

If you cannot start Epson Scan 2, try these solutions:

- Make sure your product is turned on and any interface cables are securely connected at both ends.
- If your product is connected to a USB hub, connect it directly to your computer instead.
- If you scan at a high resolution over a network, a communication error may occur. Lower the resolution.
- Make sure Epson Scan 2 is selected as your scanning program.
- Make sure your computer is not running in a power-saving mode, such as sleep or standby. If so, wake your system and restart Epson Scan 2.

- Check the connection setting and test the connection using Epson Scan 2 Utility:

**Windows 10:** Click  and select **EPSON > Epson Scan 2 Utility**. Make sure the correct product is selected. If necessary, select the **Other** tab and click **Reset**.

**Windows 8.x:** Navigate to the **Apps** screen and select **Epson Scan 2 Utility**. Make sure the correct product is selected. If necessary, select the **Other** tab and click **Reset**.

**Windows (other versions):** Click  or **Start > All Programs** or **Programs > EPSON > Epson Scan 2 > Epson Scan 2 Utility**. Make sure the correct product is selected. If necessary, select the **Other** tab and click **Reset**.

**Mac:** Open the **Applications** folder, click **Epson Software**, and click **Epson Scan 2 Utility**. Make sure the correct product is selected. If necessary, select the **Other** tab and click **Reset**.

- Make sure you do not have multiple versions of Epson Scan 2 installed. If you do, uninstall both versions and install one version.
- If you upgraded your operating system but did not reinstall Epson Scan 2, try reinstalling it.

**Parent topic:** [Solving Scanning Problems](#)

#### **Related concepts**

[Uninstall Your Product Software](#)

[Scan Resolution Guidelines](#)

#### **Related references**

[Additional Scanning Settings - Advanced Settings Tab](#)

#### **Related tasks**

[Scanning in Epson Scan 2](#)

[Starting a Scan from a Scanning Program](#)

## **Scanning is Slow**

If scanning becomes slow, try these solutions:

- Scan your original at a lower resolution, if possible.
- Make sure your system meets the requirements for your operating system. If you are scanning a high-resolution image, you may need more than the minimum requirements. If necessary, increase your system's memory or reduce the resolution.
- The scanning speed may be reduced depending on the image adjustment features in Epson Scan 2.
- If you are scanning over a wireless network, factors such as interference, network traffic, or weak signal strength may affect your scanning speed.

**Parent topic:** [Solving Scanning Problems](#)

**Related concepts**

[Scan Resolution Guidelines](#)

## Cannot Send Scans to a Cloud Service

If you cannot send a scan to a cloud service, try these solutions:

- Make sure your computer is connected to the internet.
- Make sure the login information you entered for the cloud service is correct.
- Make sure the cloud service is not down for system maintenance. Check the cloud service website for more information.

**Parent topic:** [Solving Scanning Problems](#)

## Solving Scanned Image Quality Problems

Check these sections if a scanned image on your computer screen has a quality problem.

**Note:** For solutions when using the Epson ScanSmart software, see the Epson ScanSmart help utility.

[Image Consists of a Few Dots Only](#)

[Line of Dots Appears in All Scanned Images](#)

[Straight Lines in an Image Appear Crooked](#)

[Scanned Image Quality Problems](#)

[Characters are Not Recognized During Conversion to Editable Text \(OCR\)](#)

[Image Colors are Patchy at the Edges](#)

[Ripple Patterns Appear in an Image](#)

[Streaks Appear in All Scanned Images](#)

[Scanned Image Edges are Cropped](#)

[Resetting the Epson Scan 2 Settings](#)

**Parent topic:** [Solving Problems](#)

## Image Consists of a Few Dots Only

If your scanned image consists only of a few dots, try these solutions:

- Make sure you placed your original for scanning facing the correct way.

- Make sure you select the correct **Image Type** for your original.
- If the **Image Type** setting is **Black & White**, adjust the **Threshold** and scan again. (The **Image Option** must be set to **None** or **Color Enhance**.)
- Remove any lint or dirt from your original.
- Do not press on the original or the document cover with too much force.

**Parent topic:** [Solving Scanned Image Quality Problems](#)

**Related tasks**

[Cleaning Your Product](#)

**Related topics**

[Placing Originals on the Product](#)

## Line of Dots Appears in All Scanned Images

If a line of dots appears in all your scanned images, try these solutions:

- Clean the scanner glass with a soft, dry, lint-free cloth or use a small amount of glass cleaner on the cloth, if necessary. Paper towels are not recommended.

**Caution:** Do not spray glass cleaner directly on the scanner glass.

- Make sure any interface cables are securely connected at both ends.

**Parent topic:** [Solving Scanned Image Quality Problems](#)

**Related tasks**

[Cleaning Your Product](#)

## Straight Lines in an Image Appear Crooked

If straight lines in an original appear crooked in a scanned image, make sure to place your original straight when you scan it.

Clean the scanner glass with a soft, dry, lint-free cloth or use a small amount of glass cleaner on the cloth, if necessary. Paper towels are not recommended.

Keep the document cover closed to prevent dirt or dust from getting inside.

**Parent topic:** [Solving Scanned Image Quality Problems](#)

**Related topics**

[Placing Originals on the Product](#)

## Scanned Image Quality Problems

If you encounter quality problems with your scanned image, try these solutions:

### Image is Distorted or Blurry

- Make sure your original is not wrinkled or warped. This may prevent the original from laying flat on the scanner glass.
- Do not move your original or your product during scanning.
- Your product will not operate properly while tilted at an angle. Place your product on a flat, stable surface that extends beyond its base in all directions.
- Adjust these Epson Scan 2 settings (if available) and try scanning again:
  - Make sure you select the correct **Image Type** for your original.
  - Increase the **Resolution** setting.
  - If the **Image Type** setting is **Black & White**, adjust the **Threshold** setting. (The **Image Option** must be set to **None** or **Color Enhance**.)
  - If the **Image Type** setting is **Color** or **Grayscale**, select the **Unsharp Mask** setting.
  - If the **Image Type** setting is **Black & White**, select **Text Enhancement**. If the **Image Type** setting is **Color** or **Grayscale**, change the **Text Enhancement** setting to **High**.

### Image is Too Dark

- Make sure you select the correct **Image Type** for your original.
- If the **Image Type** is set to **Auto**, **Color** or **Grayscale**, adjust the **Brightness** setting.
- Check the brightness and contrast settings of your computer monitor.

### Back of Original Image Appears in Scanned Image

- Place a piece of black paper on the back of the original and scan it again.
- Adjust these Epson Scan 2 settings (if available) and try scanning again:
  - Make sure you select the correct **Image Type** for your original.
  - Select the **Advanced Settings** tab and adjust the **Brightness** setting.
  - If the **Image Type** is set to **Black & White**, select **Text Enhancement**. If the **Image Type** is set to **Color** or **Grayscale**, change the **Text Enhancement** setting to **High**.

**Note:** The **Text Enhancement** and **Remove Background** settings depend on the selected **Image Type**.

### **Scanned Image Colors Do Not Match Original Colors**

Printed colors can never exactly match the colors on your computer monitor because printers and monitors use different color systems: monitors use RGB (red, green, and blue) and printers typically use CMYK (cyan, magenta, yellow, and black).

Check the color matching and color management capabilities of your computer, display adapter, and the software you are using to see if they are affecting the palette of colors you see on your screen.

To adjust the colors in your scanned image, adjust these Epson Scan 2 settings (if available) and try scanning again:

- Make sure you select the correct **Image Type** for your original.
- If the **Image Type** setting is **Auto**, **Color** or **Grayscale**, adjust the **Contrast** setting.
- If the **Image Type** setting is **Black & White** or **Grayscale**, adjust the **Color Enhance** setting.

**Parent topic:** [Solving Scanned Image Quality Problems](#)

#### **Related references**

[Additional Scanning Settings - Main Settings Tab](#)

[Additional Scanning Settings - Advanced Settings Tab](#)

#### **Related tasks**

[Scanning in Epson Scan 2](#)

[Scanning a Document or Photo in Epson ScanSmart](#)

## **Characters are Not Recognized During Conversion to Editable Text (OCR)**

If characters in your scanned images are not recognized during OCR conversion, try these solutions:

- Make sure your original is loaded straight on your product.
- Use an original with clear text.
- When saving scanned images as Searchable PDFs, make sure the correct OCR language is selected.
- Adjust the following Epson Scan 2 settings if available, and try scanning again:
  - On the **Main Settings** tab, make sure you select the correct **Image Type** for your original.
  - On the **Main Settings** tab, set the **Resolution** between 200 and 600 dpi.
  - On the **Advanced Settings** tab, select **Text Enhancement** and choose a setting.

**Note:** The **Text Enhancement** setting depends on the selected **Image Type**.

- If the **Image Type** is set to **Black & White**, adjust the **Threshold** setting on the **Advanced Settings** tab. (The **Image Option** must be set to **None** or **Color Enhance**.)

**Parent topic:** [Solving Scanned Image Quality Problems](#)

**Related references**

[Additional Scanning Settings - Main Settings Tab](#)

[Additional Scanning Settings - Advanced Settings Tab](#)

## Image Colors are Patchy at the Edges

If you are scanning a thick or warped original, cover its edges with paper to block external light as you scan it.

**Parent topic:** [Solving Scanned Image Quality Problems](#)

## Ripple Patterns Appear in an Image

You may see a ripple pattern (called a moiré) in scanned images of printed documents. This is caused by interference from differing pitches in the scanner's screen and your original's halftone screen. To reduce this effect, adjust these Epson Scan 2 settings (if available) and try scanning again:

- Select the **Descreening** setting.
- Select a lower **Resolution** setting.

**Parent topic:** [Solving Scanned Image Quality Problems](#)

**Related references**

[Additional Scanning Settings - Advanced Settings Tab](#)

**Related tasks**

[Scanning in Epson Scan 2](#)

[Scanning a Document or Photo in Epson ScanSmart](#)

## Streaks Appear in All Scanned Images

If streaks appear in all your scanned images, try these solutions:

- Clean the scanner glass with a soft, dry, lint-free cloth or use a small amount of glass cleaner on the cloth, if necessary. Paper towels are not recommended.
- Keep the document cover closed to prevent dirt or dust from getting inside.



**Parent topic:** [Solving Scanned Image Quality Problems](#)

**Related tasks**

[Cleaning Your Product](#)

## Scanned Image Edges are Cropped

If the edges of a scanned image are cropped, make sure your original is placed correctly for scanning. If necessary, move your original away from the edges of the scanner glass slightly.

In the Epson Scan 2 settings, set the **Edge Fill** setting to **None**.



**Parent topic:** [Solving Scanned Image Quality Problems](#)

**Related topics**

[Placing Originals on the Product](#)

## Resetting the Epson Scan 2 Settings

If you continue to experience image quality problems after trying all possible solutions, you may need to reset the Epson Scan 2 settings using the Epson Scan 2 Utility.

1. Do one of the following to start the Epson Scan 2 Utility:
  - **Windows 10:** Click  > **EPSON** > **Epson Scan 2 Utility**.
  - **Windows 8.x:** Navigate to the **Apps** screen and select **Epson Scan 2 Utility**.
  - **Windows (other versions):** Click  or **Start**, and select **All Programs** or **Programs**. Select **EPSON** > **Epson Scan 2** > **Epson Scan 2 Utility**.
  - **Mac:** Open the **Applications** folder, open the **Epson Software** folder, and select **Epson Scan 2 Utility**.
2. Click the **Other** tab.
3. Click **Reset** and confirm your choice.

**Note:** If resetting the Epson Scan 2 settings does not solve your problem, uninstall Epson Scan 2 and re-install it.

**Parent topic:** [Solving Scanned Image Quality Problems](#)

## Solving Memory Card Problems

Check these solutions if you have problems using memory cards with your product.

[Memory Card Does Not Fit Into a Slot](#)

[Cannot View or Print Photos from a Memory Card or Device](#)

[Cannot Transfer Photos to or from a Memory Card or Device](#)

**Parent topic:** [Solving Problems](#)

## Memory Card Does Not Fit Into a Slot

If a memory card does not fit properly in a slot, do not force it in. You may need to use an adapter with your memory card.

**Parent topic:** [Solving Memory Card Problems](#)

### Related references

[Memory Card Specifications](#)

### Related tasks

[Inserting a Memory Card](#)

## Cannot View or Print Photos from a Memory Card or Device

If you cannot view or print photos from a memory card or USB device inserted in your product, try these solutions:

- Make sure your memory card or device is compatible with the product.
- Make sure the files on your memory card or device are in the correct format.
- If you have too many photos on your memory card or device, you may not see all the photos you expect or may be prompted to select a group of photos by date. Reduce the number of photos on your card or select one group of photos at a time. Check the specifications for the maximum number of photos.

**Parent topic:** [Solving Memory Card Problems](#)

### Related references

[Memory Card Specifications](#)

[External Device Specifications](#)

[Supported Data Specifications](#)

### Related tasks

[Inserting a Memory Card](#)

[Connecting and Printing from a Camera](#)

### **Related topics**

[Viewing and Printing Photos](#)

## **Cannot Transfer Photos to or from a Memory Card or Device**

If you have problems transferring photos to or from a memory card or USB device inserted in your product, try these solutions:

- Make sure your memory card or device is compatible with the product.
- Make sure your product is securely connected to your computer.
- If you are transferring photos to a memory card, check the memory card's write-protect tab to make sure it is set to allow writing to the card.
- Make sure that the file sharing setting for your product is set correctly.

**Parent topic:** [Solving Memory Card Problems](#)

### **Related references**

[External Device Specifications](#)

[Memory Card Specifications](#)

### **Related tasks**

[Transferring Photos from a Memory Card to Your Computer](#)

[Setting Up File Sharing for Photo Transfers from Your Computer](#)

## **Solving USB Device Problems**

Check these solutions if you have problems using USB devices with your product.

[Cannot View or Print from a USB Device](#)

[Cannot Save Files on a USB Device](#)

[Cannot Transfer Files To or From a USB Device](#)

**Parent topic:** [Solving Problems](#)

## **Cannot View or Print from a USB Device**

If you cannot view or print photos or documents from a USB device connected to your product, try these solutions:

- Make sure memory devices are enabled on the product.
- Make sure your device is compatible with the product.
- Make sure the files on your device are in the correct format.

**Parent topic:** [Solving USB Device Problems](#)

**Related references**

[External Device Specifications](#)

[Supported Data Specifications](#)

## Cannot Save Files on a USB Device

If you cannot save files on a USB device connected to your product, try these solutions:

- Make sure the device is not write-protected.
- Make sure the device has enough available space.
- Make sure memory devices are enabled on your product.
- Make sure the device is compatible with the product.

**Parent topic:** [Solving USB Device Problems](#)

**Related references**

[External Device Specifications](#)

[Supported Data Specifications](#)

## Cannot Transfer Files To or From a USB Device

If you have problems transferring files to or from a USB device connected to your product, try these solutions:

- Make sure your device is compatible with the product.
- Make sure the device is not write-protected.
- Make sure your product is securely connected to your computer.
- Make sure that the file sharing setting for your product is enabled.

**Parent topic:** [Solving USB Device Problems](#)

**Related references**

[External Device Specifications](#)

[Supported Data Specifications](#)

## Solving CD/DVD Problems

Check these sections if you have problems printing on a CD/DVD with your product.

[Problems Printing on CDs/DVDs](#)

**Parent topic:** [Solving Problems](#)

## **Problems Printing on CDs/DVDs**

If you encounter CD/DVD printing problems, try these solutions:

### **Ink Smears on CD/DVD**

- Make sure you are printing on ink jet-printable CDs or DVDs and that the surface of the disc is dry.
- Handle printed discs carefully and let them dry for 24 hours before inserting them in a drive.
- Adjust the print quality using the Epson Photo+ software. See the Epson Photo+ help utility for details.

### **CD/DVD Jam Problems**

If a CD/DVD has jammed in the product and you see an error message, you need to remove the CD/DVD tray:

1. Cancel the print job from your computer, if necessary.
2. Slowly pull the CD/DVD tray out of the product.
3. Clear the error message.
4. If an error is still displayed, turn off the product, wait a moment, and then turn it back on.
5. If you are unable to remove the CD/DVD tray, contact Epson for support.

### **Image Not Centered on CD/DVD**

- If you are printing from a computer, adjust the print position using the Epson Photo+ software. See the Epson Photo+ help utility for details.
- If you are printing from the control panel, adjust the printing position using the product menus.

### **Faint Image on CD/DVD**

If your printed image is faint, adjust the print quality using the Epson Photo+ software. See the Epson Photo+ help utility for details.

**Parent topic:** [Solving CD/DVD Problems](#)

### **Related concepts**

[Printing with Epson Photo+](#)

### **Related references**

[Where to Get Help](#)

## Related tasks

[Cancelling Printing From the LCD Screen](#)

# Uninstall Your Product Software

If you have a problem that requires you to uninstall and re-install your software, follow the instructions for your operating system.



[Uninstalling Product Software - Windows](#)

[Uninstalling Product Software - Mac](#)

**Parent topic:** [Solving Problems](#)

## Uninstalling Product Software - Windows

You can uninstall and then re-install your product software to solve certain problems.

1. Turn off the product.
2. Close any open programs or applications.
3. Disconnect any interface cables.
4. Do one of the following:
  - **Windows 10:** Click  and select  (Settings) > **Apps** or **System** > **Apps & features**. Then select the program you want to uninstall and select **Uninstall**.
  - **Windows 8.x:** Navigate to the **Apps** screen and select **Control Panel** > **Programs** > **Programs and Features**. Select the uninstall option for your Epson product, then select **Uninstall/Change**.

**Note:** If you see a **User Account Control** window, click **Yes** or **Continue**.

Select your product again, if necessary, then select **OK**, and click **Yes** to confirm the uninstallation.

- **Windows (other versions):** Click  or **Start**, and select **All Programs** or **Programs**. Select **EPSON**, select your product, then click **EPSON Printer Software Uninstall**.

**Note:** If you see a **User Account Control** window, click **Yes** or **Continue**.

In the next window, select your product and click **OK**. Then follow any on-screen instructions.

5. Do one of the following to uninstall Epson Event Manager, then follow any on-screen instructions:
  - **Windows 10/8.x:** Select **Epson Event Manager** and click **Uninstall**.
  - **Windows 7/Windows Vista:** Open the Windows **Control Panel** utility. Select **Programs and Features**. (In Classic view, select **Programs** and click **Uninstall a program**.) Select **Epson Event Manager** and click **Uninstall/Change**.
6. Do one of the following to uninstall Epson Scan 2, then follow any on-screen instructions:
  - **Windows 10:** Select **Epson Scan 2** and click **Uninstall**.
  - **Windows 8.x/Windows 7/Windows Vista:** Select **Epson Scan 2** and click **Uninstall/Change**.
7. Do one of the following to uninstall Epson ScanSmart, then follow any on-screen instructions:
  - **Windows 10:** Select **Epson ScanSmart** and click **Uninstall**.
  - **Windows 8.x/Windows 7/Windows Vista:** Select **Epson ScanSmart** and click **Uninstall/Change**.
8. Restart your computer, then see the *Start Here* sheet to re-install your software.

**Note:** If you find that re-installing your product software does not solve a problem, contact Epson.

**Parent topic:** [Uninstall Your Product Software](#)

**Related references**

[Where to Get Help](#)

## Uninstalling Product Software - Mac

In most cases, you do not need to uninstall your product software before re-installing it. However, you can download the Uninstaller utility from the Epson support website to uninstall your product software as described here.

**Note:** If you find that re-installing your product software does not solve a problem, contact Epson.

1. To download the Uninstaller utility, visit [latin.epson.com/support](http://latin.epson.com/support) and select your product.
2. Click **Downloads**.
3. Select your operating system, click **Utilities**, locate the Uninstaller utility, and click **Download**.
4. Run the file you downloaded.
5. Double-click the **Uninstaller** icon.

6. In the Epson Uninstaller screen, select the checkbox for each software program you want to uninstall.
7. Click **Uninstall**.
8. Follow the on-screen instructions to uninstall the software.
9. Reinstall your product software.

**Note:** If you uninstall the printer driver and your product name remains in the **Print & Fax**, **Print & Scan**, or **Printers & Scanners** window, select your product name and click the – (remove) icon to remove it.

**Parent topic:** [Uninstall Your Product Software](#)

#### **Related references**

[Where to Get Help](#)

## **Where to Get Help**

If you need additional help with your Epson product, contact Epson.

Epson provides these technical support services:

#### **Internet Support**

Visit Epson's support website at [latin.epson.com/support](http://latin.epson.com/support) for solutions to common problems. You can download drivers and documentation, get FAQs and troubleshooting advice, or e-mail Epson with your questions.

#### **Speak to a Support Representative**

Before you call Epson for support, please have the following information ready:

- Product name
- Product serial number (located on a label on the product)
- Proof of purchase (such as a store receipt) and date of purchase
- Computer configuration
- Description of the problem

Then call:



<b>Country</b>	<b>Telephone</b>
Argentina	(54 11) 5167-0300 0800-288-37766
Bolivia*	800-100-116
Brazil	State capitals and metropolitan areas: 3004-6627 Other areas: 0800-377-6627 / 0800-EPSONBR
Chile	(56 2) 2484-3400
Colombia	Bogota: (57 1) 592-2200 Other cities: 018000-915235
Costa Rica	800-377-6627
Dominican Republic*	1-888-760-0068
Ecuador*	1-800-000-044
El Salvador*	800-6570
Guatemala*	1-800-835-0358
Mexico	Mexico City: (52 55) 1323-2052 Other cities: 01-800-087-1080
Nicaragua*	00-1-800-226-0368
Panama*	00-800-052-1376
Paraguay	009-800-521-0019
Peru	Lima: (51 1) 418-0210 Other cities: 0800-10126
Uruguay	00040-5210067
Venezuela	(58 212) 240-1111

\* Contact your local phone company to call this toll-free number from a mobile phone.

If your country does not appear in the list, contact the sales office in the nearest country. Toll or long distance charges may apply.

**Purchase Supplies and Accessories**

You can purchase genuine Epson ink and paper from an Epson authorized reseller. To find the nearest reseller, visit [latin.epson.com](http://latin.epson.com) or call your nearest Epson sales office.

**Parent topic:** [Solving Problems](#)

---

# Technical Specifications

These sections list the technical specifications for your product.

[Windows System Requirements](#)

[Mac System Requirements](#)

[Paper Specifications](#)

[Printable Area Specifications](#)

[Scanning Specifications](#)

[Ink Specifications](#)

[Dimension Specifications](#)

[Electrical Specifications](#)

[Environmental Specifications](#)

[Interface Specifications](#)

[Memory Card Specifications](#)

[External Device Specifications](#)

[Supported Data Specifications](#)

[Network Interface Specifications](#)

## Windows System Requirements

To use your product and its software, your computer should use one of these Microsoft operating systems:

- Windows 10
- Windows 8.x
- Windows 7
- Windows Vista
- Windows XP Professional x64 Edition
- Windows XP SP3 or later
- Windows Server 2019
- Windows Server 2016
- Windows Server 2012 R2
- Windows Server 2012

- Windows Server 2008 R2
- Windows Server 2008
- Windows Server 2003 R2
- Windows Server 2003 SP2 or later

Windows Server supports only the printer driver and Epson Scan 2; any additional included software is not supported.

**Note:** For the latest product software available for your operating system, visit the Epson support site at [latin.epson.com/support](http://latin.epson.com/support), select your product, and select **Downloads**.

**Parent topic:** [Technical Specifications](#)

## Mac System Requirements

To use your product and its software, your Mac should use one of these operating systems:

- macOS 11.x
- macOS 10.15.x
- macOS 10.14.x
- macOS 10.13.x
- macOS 10.12.x
- OS X 10.11.x
- OS X 10.10.x
- OS X 10.9.x
- OS X 10.8.x
- OS X 10.7.x

**Note:** For the latest product software available for your operating system, visit the Epson support site at [latin.epson.com/support](http://latin.epson.com/support), select your product, and select **Downloads**.

**Parent topic:** [Technical Specifications](#)

## Paper Specifications

**Note:** Since the quality of any particular brand or type of paper may be changed by the manufacturer at any time, Epson cannot guarantee the quality of any non-Epson brand or type of paper. Always test a sample of paper stock before purchasing large quantities or printing large jobs.

### Single-sheets

#### Size

A4 (8.3 × 11.7 inches [210 × 297 mm])

A5 (5.8 × 8.2 inches [148 × 210 mm])

A6 (4.1 × 5.8 inches [105 × 148 mm])

16:9 wide (4 × 7.1 inches [102 × 181 mm])

Letter (8.5 × 11 inches [216 × 279 mm])

Legal (8.5 × 14 inches [216 × 356 mm])

8.5 × 13 inches (216 × 330 mm)

8 × 10 inches (203 × 254 mm)

5 × 7 inches (127 × 178 mm)

4 × 6 inches (102 × 152 mm)

3.5 × 5 inches (89 × 127 mm)

Executive (7.25 × 10.5 inches [184 × 267 mm])

Mexico-Oficio (8.5 × 13.4 inches [216 × 340 mm])

Oficio 9 (8.46 × 12.4 inches [215 × 315 mm])

Half Letter (5.5 × 8.5 inches [140 × 216 mm])

**L8180 supports the following sizes in addition to the ones listed above:**

11 × 17 inches (279 × 432 mm)

A3 (11.7 × 16.5 inches [297 × 420 mm])

A3+ (13 × 19 inches [329 × 483 mm])

**Paper types**

Plain paper and thick paper

**Note:** Your product also supports compatible papers distributed by Epson. See the link at the end of this topic for a list of compatible Epson papers.

**Weight**

Plain paper: 17 lb (64 g/m<sup>2</sup>) to 24 lb (90 g/m<sup>2</sup>)

**Envelopes**

**Size**

No. 10 (4.1 × 9.5 inches [105 × 241 mm])

**Paper types**

Plain bond paper

**Weight**

20 lb (75 g/m<sup>2</sup>) to 27 lb (100 g/m<sup>2</sup>)

Parent topic: [Technical Specifications](#)

**Related references**

[Compatible Epson Papers](#)

## Printable Area Specifications

**Single sheets (with borders)**

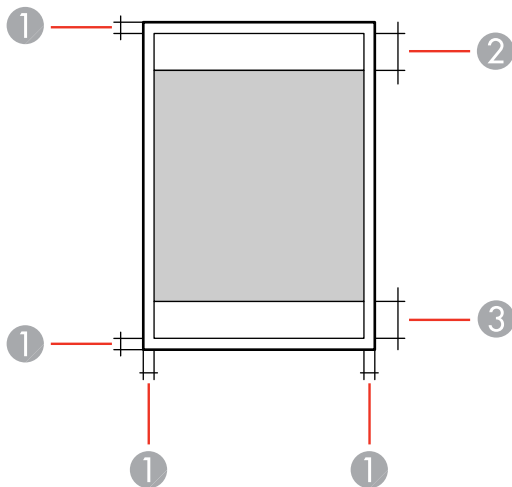

- 1 Top/bottom/right/left: 0.12 inch (3 mm) minimum
- 2 Reduced print quality area/top: 1.62 inches (41 mm) minimum
- 3 Reduced print quality area/bottom: 1.46 inches (37 mm) minimum

**Note:** When printing from the rear paper feed slot, you cannot print in the area 0.8 inch (20 mm) from the bottom edge.

### Single sheets (borderless)

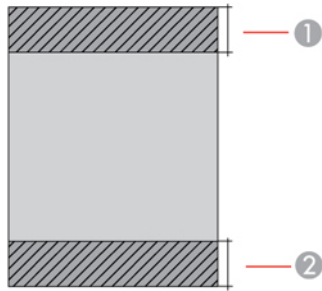

- 1 Top: 1.73 inches (44 mm) minimum
- 2 Bottom: 1.57 inches (40 mm) minimum

### Envelopes

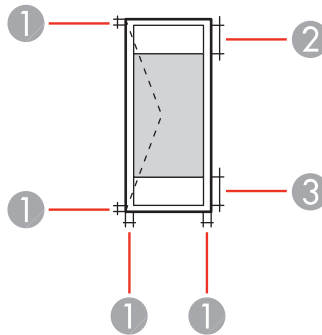

- 1 Left/right/top/bottom: 0.12 inch (3 mm) minimum
- 2 Reduced print quality area/left: 0.71 inch (18 mm) minimum
- 3 Reduced print quality area/right: 1.62 inches (41 mm) minimum

Parent topic: [Technical Specifications](#)

## Scanning Specifications

<b>Scanner type</b>	Flatbed, color
<b>Photoelectric device</b>	CIS
<b>Maximum document size</b>	<b>L8160:</b> A4/Letter <b>L8180:</b> Legal
<b>Scanning resolution</b>	1200 dpi (main scan) 4800 dpi (sub scan)
<b>Image data</b>	Color: 48 bits per pixel (16 bits per pixel per color) internal 24 bits per pixel (8 bits per pixel per color) external Grayscale: 16 bits per pixel internal 8 bits per pixel external Black and white: 16 bits per pixel internal 1 bit per pixel external
<b>Light source</b>	LED

Parent topic: [Technical Specifications](#)

## Ink Specifications

**Note:** This product is designed to work with genuine Epson inks. Non-Epson ink or any other ink not specified for this printer could cause damage not covered by Epson's warranties.



The ink bottles that are used for initial product setup have a lower yield due to the ink charging process. This process is carried out the first time you turn on the printer and guarantees better performance. Yields vary considerably based on print jobs, print settings, paper type, frequency of use, and temperature. Do not load paper before refilling the ink tanks.

Check the ink levels in your product frequently, and refill the ink tanks if necessary.

<b>Color</b>	Black, Photo Black, Gray, Cyan, Magenta, Yellow
<b>Ink life</b>	Do not use if the date on the package has expired
<b>Temperature</b>	Storage: -22 to 104 °F (-30 to 40 °C) 1 month at 104 °F (40 °C) Ink freezes at 3 °F (-16 °C) Ink thaws and is usable after approximately 3 hours at 77 °F (25 °C)

**Parent topic:** [Technical Specifications](#)

**Related references**

[Ink Bottle and Maintenance Box Part Numbers](#)

## Dimension Specifications

### L8160:

<b>Height</b>	Stored: 6.4 inches (162 mm) Printing: 13.7 inches (347 mm)
<b>Width</b>	Stored: 15.9 inches (403 mm) Printing: 15.9 inches (403 mm)
<b>Depth</b>	Stored: 14.5 inches (369 mm) Printing: 24.1 inches (612 mm)
<b>Weight</b> (without ink or power cord)	18.5 lb (8.4 kg)

### L8180:

<b>Height</b>	Stored: 6.7 inches (169 mm) Printing: 16.9 inches (430 mm)
<b>Width</b>	Stored: 20.6 inches (523 mm) Printing: 20.6 inches (523 mm)
<b>Depth</b>	Stored: 14.9 inches (379 mm) Printing: 29.8 inches (758 mm)
<b>Weight</b> (without ink or power cord)	24.5 lb (11.1 kg)

Parent topic: [Technical Specifications](#)

## Electrical Specifications

**Note:** Check the label on the product for its voltage.

<b>Power supply rating</b>	100 to 120 V 220 to 240 V
<b>Rated frequency range</b>	50 to 60 Hz
<b>Rated current</b>	100 to 120 V model: 0.6 to 0.7 A 220 to 240 V model: 0.3 A
<b>Power consumption</b> (100 to 120 V model)	Standalone copying: Approximately 17.0 W (ISO/IEC24712) Ready mode: approximately 7.4 to 7.5 W Sleep mode: approximately 0.8 W Power off mode: approximately 0.2 W
<b>Power consumption</b> (220 to 240 V model)	Standalone copying: Approximately 17.0 W (ISO/IEC24712) Ready mode: approximately 7.5 W Sleep mode: approximately 0.8 to 0.9 W Power off mode: approximately 0.2 to 0.3 W

Parent topic: [Technical Specifications](#)

## Environmental Specifications

<b>Temperature</b>	Operating: 50 to 95 °F (10 to 35 °C) Storage: –4 to 104 °F (–20 to 40 °C) 1 month at 104 °F (40 °C)
<b>Humidity</b> (without condensation)	Operating: 20 to 80% RH Storage: 5 to 85% RH

**Parent topic:** [Technical Specifications](#)

## Interface Specifications

<b>Interface type</b>	Hi-Speed USB (Device Class for computers); USB 3.0 cables not supported Hi-Speed USB (for Mass storage class for external storage)
-----------------------	---

**Note:** Epson cannot guarantee the operation of externally connected devices.

**Parent topic:** [Technical Specifications](#)

## Memory Card Specifications

**Note:** Cards marked with an asterisk (\*) require an adapter; consult your adapter documentation for details on using it.

**Compatible types and maximum capacities**

miniSD\*: 2GB  
miniSDHC\*: 32GB  
microSD\*: 2GB  
microSDHC\*: 32GB  
microSDXC\*: 64GB  
SD: 2GB  
SDHC: 32GB  
SDXC: 64GB

Parent topic: [Technical Specifications](#)

## External Device Specifications

Do not use devices with the following requirements:

- Dedicated driver
- Security settings
- A built-in USB hub

**Note:** Use only external storage devices with independent AC power sources. External storage devices that are powered via USB are not recommended. Epson cannot guarantee the operation of externally connected devices.

<b>CD-ROM/CD-R drive</b>	700MB maximum capacity (CD-RW is not supported)
<b>DVD-ROM/DVD-R/Blu-ray drive</b>	4.7GB maximum capacity (DVD-RW, DVD+R, DVD+RW, DVD-RAM, and Blu-ray Disc are not supported)
<b>USB flash drive, HDD, or card reader</b>	2TB (formatted in FAT, FAT32, or exFAT)

**Note:** If you have a multi-card reader, only insert one memory card at a time. Multi-card readers with two or more memory cards inserted are not supported.

Parent topic: [Technical Specifications](#)

## Supported Data Specifications

You can use memory devices with your product containing files that meet these specifications.

<b>File format</b>	JPEG with the Exif version 2.31 standard taken by digital cameras with the DCF (Design Rule for Camera File system) version 1.0 or 2.0 compliant
<b>Image size</b>	80 × 80 pixels to 10200 × 10200 pixels
<b>File size</b>	Up to 2GB
<b>Number of files</b>	Up to 9990

Parent topic: [Technical Specifications](#)

## Network Interface Specifications

**Note:** Wireless LAN standard complies with either IEEE802.11b/g or IEEE802.11 b/g/n, depending on purchase location.

### Wi-Fi

<b>Standard</b>	IEEE802.11b/g/n; complies with either IEEE802.11b/g or IEEE802.11b/g/n, depending on purchase location
<b>Security</b>	WEP (64/128 bit) WPA2-PSK (AES); supported by Wi-Fi Direct WPA3-SAE (AES)
<b>Frequency range</b>	2.4 GHz
<b>Channels</b>	1/2/3/4/5/6/7/8/9/10/11/12/13
<b>Communication mode</b>	Infrastructure mode Wi-Fi Direct (Simple AP)

**Note:** Wi-Fi Direct (Simple AP) mode not available for IEEE 802.11b.

## Ethernet

### Standards

IEEE802.3i (10BASE-T)

IEEE802.3u (100BASE-TX)

**Note:** To prevent risk of radio interference, use a Category-5e or higher shielded twisted pair cable.

IEEE802.3az (Energy Efficient Ethernet); connected device should be IEEE802.3az compliant

### Communication mode

Auto, 10Mbps Full duplex, 10Mbps Half duplex, 100Mbps Full duplex, 100Mbps Half duplex

### Connector

RJ-45

### Security Protocol

- SSL/TLS; HTTPS Server/Client and IPPS
- SNMPv3

**Parent topic:** [Technical Specifications](#)

---

## Notices

Check these sections for important notices about your product.

[Important Safety Instructions](#)

[FCC Compliance Statement](#)

[Binding Arbitration and Class Waiver](#)

[Trademarks](#)

[Copyright Notice](#)

## Important Safety Instructions

Before using your Epson product, read and follow these safety instructions.

[General Product Safety Instructions](#)

[Wireless Connection Safety Instructions](#)

[LCD Screen Safety Instructions](#)

**Parent topic:** [Notices](#)

## General Product Safety Instructions

- Be sure to follow all warnings and instructions marked on the product.
- Use only the type of power source indicated on the product's label.
- Use only the power cord that comes with the product. Use of another cord may cause fires or shock. Do not use the cord with any other equipment.
- Make sure the AC power cord meets the relevant local safety standard.
- Place the product near a wall outlet where the plug can be easily unplugged.
- Avoid plugging the product into an outlet on the same circuit as a photo copier or air control system that regularly switches on and off, or on an outlet controlled by a wall switch or timer.
- Do not let the power cord become damaged or frayed. Place it to avoid abrasions, cuts, fraying, crimping, and kinking. Do not place objects on top of it and do not allow it to be stepped on or run over. Be careful to keep the cord straight at each end.
- If you use an extension cord with the product, make sure the total ampere rating of the devices plugged into the extension cord does not exceed the cord's ampere rating. Also, make sure the total ampere rating of all devices plugged into the wall outlet does not exceed the wall outlet's ampere rating.

- Always turn off the product using the power button, and wait until the power light stops flashing before unplugging the product or cutting off power to the electrical outlet.
- If you will not be using the product for a long period, unplug the power cord from the electrical outlet.
- Place the product on a flat, stable surface that extends beyond its base in all directions. It will not operate properly if it is tilted or at an angle.
- Allow space behind the product for the cables, and space above the product so that you can fully raise the document cover.
- Leave enough space in front of the product for the paper to be fully ejected.
- Avoid locations that are subject to rapid changes in heat or humidity, shocks or vibrations, or dust.
- Do not place or store the product outdoors.
- Do not place the product near excessive heat sources or in direct sunlight.
- Leave enough room around the product for sufficient ventilation. Do not block or cover openings in the case or insert objects through the slots.
- Keep the product away from potential sources of electromagnetic interference, such as loudspeakers or the base units of cordless telephones.
- Keep your product at least 8.7 inches (22 cm) away from cardiac pacemakers to prevent your product's radio waves from affecting the operation of the pacemaker.
- When connecting the product to a computer or other device with a cable, ensure the correct orientation of the connectors. Each connector has only one correct orientation. Inserting a connector in the wrong orientation may damage both devices connected by the cable.
- Do not sit or lean on the product. Do not place heavy objects on the product.
- Do not touch the flat white cable, translucent film, or ink tubes inside the product.
- Do not move the print head by hand; this may damage the product.
- Do not put your hand inside the product while it is printing.
- Do not spill liquid on the product or use the product with wet hands.
- Do not use aerosol products that contain flammable gases inside or around the product. Doing so may cause fire.
- Do not press too hard on the scanner glass when placing originals.
- Do not open the scanner section while the product is copying, printing, scanning, or performing any other functions.
- Be careful not to trap your fingers when closing the document cover or scanner unit.



- Except as specifically explained in your documentation, do not attempt to service or disassemble the product yourself.
- Unplug the product and refer servicing to qualified service personnel under the following conditions: if the power cord or plug is damaged; if liquid has entered the product; if the product has been dropped or the case damaged; if the product does not operate normally or exhibits a distinct change in performance. Adjust only those controls that are covered by the operating instructions.
- If any of the ink tanks are not filled up to the lower line, refill the ink soon. Prolonged use of the product when the ink level is below the lower line could damage the product.
- Before transporting the product, make sure that the transportation lock is set to the locked position and that the print head is in the home (far right) position.
- When storing or transporting the product, do not tilt it, stand it on its side, or turn it upside down; otherwise, ink may leak.
- Some users that print extensively may receive a message informing them that the ink waste pad is full. The duration of the pad depends on the amount of use and usage conditions such as high humidity, heat or dusty conditions that require more cleaning cycles. The Epson Status Monitor and warning light on the control panel will indicate when the waste pad needs to be replaced. The ink pad is not a user serviceable part. Please seek service from an Epson Authorized Service Center or consider a new printer if your printing needs have changed or the printer has had a long period of extensive use.

**Parent topic:** [Important Safety Instructions](#)

## Wireless Connection Safety Instructions

Radio waves from this product may adversely affect the operation of medical equipment or automatically controlled devices, such as pacemakers, automatic doors or fire alarms. When using this product near such devices or inside a medical facility, follow the directions from authorized staff members at the facility, and follow all posted warnings and directions on the device to avoid causing an accident.

**Parent topic:** [Important Safety Instructions](#)

## LCD Screen Safety Instructions

- Use only a dry, soft cloth to clean the LCD screen. Do not use liquid or chemical cleansers.
- If the LCD screen is damaged, contact Epson. If the liquid crystal solution gets on your hands, wash them thoroughly with soap and water. If the liquid crystal solution gets into your eyes, flush them immediately with water. If discomfort or vision problems remain after a thorough flushing, see a doctor immediately.
- Do not press too hard on the LCD screen or subject it to heavy impacts.
- Do not use a pointy or sharp object, such as a pen or your fingernail, to operate the LCD screen.

- If the LCD screen chips or cracks, do not touch or attempt to remove the broken pieces; contact Epson for support.
- Do not subject your product to sudden changes in temperature or humidity; this may cause condensation to develop inside the LCD screen and degrade its performance.
- The LCD screen may contain a few small bright or dark spots, and may display uneven brightness. These are normal and do not indicate that the screen is damaged in any way.

**Parent topic:** [Important Safety Instructions](#)

## FCC Compliance Statement

### For United States Users

This equipment has been tested and found to comply with the limits for a Class B digital device, pursuant to Part 15 of the FCC Rules. These limits are designed to provide reasonable protection against harmful interference in a residential installation. This equipment generates, uses, and can radiate radio frequency energy and, if not installed and used in accordance with the instructions, may cause harmful interference to radio or television reception. However, there is no guarantee that interference will not occur in a particular installation. If this equipment does cause interference to radio and television reception, which can be determined by turning the equipment off and on, the user is encouraged to try to correct the interference by one or more of the following measures:

- Reorient or relocate the receiving antenna.
- Increase the separation between the equipment and receiver.
- Connect the equipment into an outlet on a circuit different from that to which the receiver is connected.
- Consult the dealer or an experienced radio/TV technician for help.

### WARNING

The connection of a non-shielded equipment interface cable to this equipment will invalidate the FCC Certification or Declaration of this device and may cause interference levels which exceed the limits established by the FCC for this equipment. It is the responsibility of the user to obtain and use a shielded equipment interface cable with this device. If this equipment has more than one interface connector, do not leave cables connected to unused interfaces. Changes or modifications not expressly approved by the manufacturer could void the user's authority to operate the equipment.

### For Canadian Users

CAN ICES-3(B)/NMB-3(B)

**Parent topic:** [Notices](#)

# Binding Arbitration and Class Waiver

## 1. DISPUTES, BINDING INDIVIDUAL ARBITRATION, AND WAIVER OF CLASS ACTIONS AND CLASS ARBITRATIONS

1.1 **Disputes.** The terms of this Section 1 shall apply to all Disputes between you and Epson. The term "Dispute" is meant to have the broadest meaning permissible under law and includes any dispute, claim, controversy or action between you and Epson arising out of or relating to this Agreement, Epson branded products (hardware and including any related software), or other transaction involving you and Epson, whether in contract, warranty, misrepresentation, fraud, tort, intentional tort, statute, regulation, ordinance, or any other legal or equitable basis. "DISPUTE" DOES NOT INCLUDE IP CLAIMS, or more specifically, a claim or cause of action for (a) trademark infringement or dilution, (b) patent infringement, (c) copyright infringement or misuse, or (d) trade secret misappropriation (an "IP Claim"). You and Epson also agree, notwithstanding Section 1.6, that a court, not an arbitrator, may decide if a claim or cause of action is for an IP Claim.

1.2 **Binding Arbitration.** You and Epson agree that all Disputes shall be resolved by binding arbitration according to this Agreement. **ARBITRATION MEANS THAT YOU WAIVE YOUR RIGHT TO A JUDGE OR JURY IN A COURT PROCEEDING AND YOUR GROUNDS FOR APPEAL ARE LIMITED.**

Pursuant to this Agreement, binding arbitration shall be administered by JAMS, a nationally recognized arbitration authority, pursuant to its code of procedures then in effect for consumer related disputes, but excluding any rules that permit joinder or class actions in arbitration (for more detail on procedure, see Section 1.6 below). You and Epson understand and agree that (a) the Federal Arbitration Act (9 U.S.C. §1, et seq.) governs the interpretation and enforcement of this Section 1, (b) this Agreement memorializes a transaction in interstate commerce, and (c) this Section 1 shall survive termination of this Agreement.

1.3 **Pre-Arbitration Steps and Notice.** Before submitting a claim for arbitration, you and Epson agree to try, for sixty (60) days, to resolve any Dispute informally. If Epson and you do not reach an agreement to resolve the Dispute within the sixty (60) days, you or Epson may commence an arbitration. Notice to Epson must be addressed to: Epson America, Inc., ATTN: Legal Department, 3131 Katella Ave., Los Alamitos, CA 90720 (the "Epson Address"). The Dispute Notice to you will be sent to the most recent address Epson has in its records for you. For this reason, it is important to notify us if your address changes by emailing us at [EAILEgal@ea.epson.com](mailto:EAILEgal@ea.epson.com) or writing us at the Epson Address above. Notice of the Dispute shall include the sender's name, address and contact information, the facts giving rise to the Dispute, and the relief requested (the "Dispute Notice"). Following receipt of the Dispute Notice, Epson and you agree to act in good faith to resolve the Dispute before commencing arbitration.

1.4 **Small Claims Court.** Notwithstanding the foregoing, you may bring an individual action in the small claims court of your state or municipality if the action is within that court's jurisdiction and is pending only in that court.

**1.5 WAIVER OF CLASS ACTIONS AND CLASS ARBITRATIONS. YOU AND EPSON AGREE THAT EACH PARTY MAY BRING DISPUTES AGAINST THE OTHER PARTY ONLY IN AN INDIVIDUAL CAPACITY, AND NOT AS A PLAINTIFF OR CLASS MEMBER IN ANY CLASS OR REPRESENTATIVE PROCEEDING, INCLUDING WITHOUT LIMITATION FEDERAL OR STATE CLASS ACTIONS, OR CLASS ARBITRATIONS. CLASS ACTION LAWSUITS, CLASS-WIDE ARBITRATIONS, PRIVATE ATTORNEY-GENERAL ACTIONS, AND ANY OTHER PROCEEDING WHERE SOMEONE ACTS IN A REPRESENTATIVE CAPACITY ARE NOT ALLOWED. ACCORDINGLY, UNDER THE ARBITRATION PROCEDURES OUTLINED IN THIS SECTION, AN ARBITRATOR SHALL NOT COMBINE OR CONSOLIDATE MORE THAN ONE PARTY'S CLAIMS WITHOUT THE WRITTEN CONSENT OF ALL AFFECTED PARTIES TO AN ARBITRATION PROCEEDING.**

**1.6 Arbitration Procedure.** If you or Epson commences arbitration, the arbitration shall be governed by the rules of JAMS that are in effect when the arbitration is filed, excluding any rules that permit arbitration on a class or representative basis (the "JAMS Rules"), available at <https://www.jamsadr.com/about/> or by calling +1-949-224-1810 (from outside the U.S.) or 1-800-352-5267 (from within the U.S.), and under the rules set forth in this Agreement. All Disputes shall be resolved by a single neutral arbitrator, and both parties shall have a reasonable opportunity to participate in the selection of the arbitrator. The arbitrator is bound by the terms of this Agreement. The arbitrator, and not any federal, state or local court or agency, shall have exclusive authority to resolve all disputes arising out of or relating to the interpretation, applicability, enforceability or formation of this Agreement, including any claim that all or any part of this Agreement is void or voidable. Notwithstanding this broad delegation of authority to the arbitrator, a court may determine the limited question of whether a claim or cause of action is for an IP Claim, which is excluded from the definition of "Disputes" in Section 1.1 above. The arbitrator shall be empowered to grant whatever relief would be available in a court under law or in equity. The arbitrator may award you the same damages as a court could, and may award declaratory or injunctive relief only in favor of the individual party seeking relief and only to the extent necessary to provide relief warranted by that party's individual claim. In some instances, the costs of arbitration can exceed the costs of litigation and the right to discovery may be more limited in arbitration than in court. The arbitrator's award is binding and may be entered as a judgment in any court of competent jurisdiction.

You may choose to engage in arbitration hearings by telephone. Arbitration hearings not conducted by telephone shall take place in a location reasonably accessible from your primary residence, or in Orange County, California, at your option.

a) Initiation of Arbitration Proceeding. If either you or Epson decides to arbitrate a Dispute, both parties agree to the following procedure:

(i) Write a Demand for Arbitration. The demand must include a description of the Dispute and the amount of damages sought to be recovered. You can find a copy of a Demand for Arbitration at <http://www.jamsadr.com> ("Demand for Arbitration").

(ii) Send three copies of the Demand for Arbitration, plus the appropriate filing fee, to: JAMS, 500 North State College Blvd., Suite 600 Orange, CA 92868, U.S.A.

(iii) Send one copy of the Demand for Arbitration to the other party (same address as the Dispute Notice), or as otherwise agreed by the parties.

b) Hearing Format. During the arbitration, the amount of any settlement offer made shall not be disclosed to the arbitrator until after the arbitrator determines the amount, if any, to which you or Epson is entitled. The discovery or exchange of non-privileged information relevant to the Dispute may be allowed during the arbitration.

c) Arbitration Fees. Epson shall pay, or (if applicable) reimburse you for, all JAMS filings and arbitrator fees for any arbitration commenced (by you or Epson) pursuant to provisions of this Agreement.

d) Award in Your Favor. For Disputes in which you or Epson seeks \$75,000 or less in damages exclusive of attorney's fees and costs, if the arbitrator's decision results in an award to you in an amount greater than Epson's last written offer, if any, to settle the Dispute, Epson will: (i) pay you \$1,000 or the amount of the award, whichever is greater; (ii) pay you twice the amount of your reasonable attorney's fees, if any; and (iii) reimburse you for any expenses (including expert witness fees and costs) that your attorney reasonably accrues for investigating, preparing, and pursuing the Dispute in arbitration. Except as agreed upon by you and Epson in writing, the arbitrator shall determine the amount of fees, costs, and expenses to be paid by Epson pursuant to this Section 1.6d).

e) Attorney's Fees. Epson will not seek its attorney's fees and expenses for any arbitration commenced involving a Dispute under this Agreement. Your right to attorney's fees and expenses under Section 1.6d) above does not limit your rights to attorney's fees and expenses under applicable law; notwithstanding the foregoing, the arbitrator may not award duplicative awards of attorney's fees and expenses.

**1.7 Opt-out. You may elect to opt-out (exclude yourself) from the final, binding, individual arbitration procedure and waiver of class and representative proceedings specified in this Agreement by sending a written letter to the Epson Address within thirty (30) days of your assent to this Agreement (including without limitation the purchase, download, installation of the Software or other applicable use of Epson Hardware, products and services) that specifies (i) your name, (ii) your mailing address, and (iii) your request to be excluded from the final, binding individual arbitration procedure and waiver of class and representative proceedings specified in this Section 1. In the event that you opt-out consistent with the procedure set forth above, all other terms shall continue to apply, including the requirement to provide notice prior to litigation.**

**1.8 Amendments to Section 1.** Notwithstanding any provision in this Agreement to the contrary, you and Epson agree that if Epson makes any future amendments to the dispute resolution procedure and class action waiver provisions (other than a change to Epson's address) in this Agreement, Epson will obtain your affirmative assent to the applicable amendment. If you do not affirmatively assent to the applicable amendment, you are agreeing that you will arbitrate any Dispute between the parties in accordance with the language of this Section 1 (or resolve disputes as provided for in Section 1.7, if you timely elected to opt-out when you first assented to this Agreement).

**1.9 Severability.** If any provision in this Section 1 is found to be unenforceable, that provision shall be severed with the remainder of this Agreement remaining in full force and effect. **The foregoing shall not apply to the prohibition against class or representative actions as provided in Section 1.5. This means that if Section 1.5 is found to be unenforceable, the entire Section 1 (but only Section 1) shall be null and void.**

Parent topic: [Notices](#)

## Trademarks

EPSON® and Epson Smart Panel® are registered trademarks, EPSON Exceed Your Vision is a registered logomark, and Epson Connect™, and Remote Print™ are trademarks of Seiko Epson Corporation.

Windows is a registered trademark of Microsoft Corporation in the United States and/or other countries.

Mac, macOS, OS X, ColorSync, AirPrint, iPad, iPhone and iPod touch, are trademarks of Apple Inc., registered in the U.S. and other countries. App Store is a service mark of Apple Inc., registered in the U.S. and other countries.

Use of the Works with Apple badge means that an accessory has been designed to work specifically with the technology identified in the badge and has been certified by the developer to meet Apple performance standards.

Google® is a registered trademark and Android™, Chromebook™, Google Chrome™, and Google Drive™ are trademarks of Google LLC.

Wi-Fi Direct® is a registered trademark of Wi-Fi Alliance®.

General Notice: Other product names used herein are for identification purposes only and may be trademarks of their respective owners. Epson disclaims any and all rights in those marks.



Parent topic: [Notices](#)

## Copyright Notice

All rights reserved. No part of this publication may be reproduced, stored in a retrieval system, or transmitted in any form or by any means, electronic, mechanical, photocopying, recording, or otherwise, without the prior written permission of Seiko Epson Corporation. The information contained herein is

designed only for use with this Epson product. Epson is not responsible for any use of this information as applied to other products.

Neither Seiko Epson Corporation nor its affiliates shall be liable to the purchaser of this product or third parties for damages, losses, costs, or expenses incurred by purchaser or third parties as a result of: accident, misuse, or abuse of this product or unauthorized modifications, repairs, or alterations to this product, or (excluding the U.S.) failure to strictly comply with Seiko Epson Corporation's operating and maintenance instructions.

Seiko Epson Corporation shall not be liable for any damages or problems arising from the use of any options or any consumable products other than those designated as Original Epson Products or Epson Approved Products by Seiko Epson Corporation.

Seiko Epson Corporation shall not be held liable for any damage resulting from electromagnetic interference that occurs from the use of any interface cables other than those designated as Epson approved Products by Seiko Epson Corporation.

This information is subject to change without notice.

[libTIFF Software Acknowledgment](#)

[A Note Concerning Responsible Use of Copyrighted Materials](#)

[Default Delay Times for Power Management for Epson Products](#)

[Copyright Attribution](#)

**Parent topic:** [Notices](#)

## **libTIFF Software Acknowledgment**

Copyright © 1988-1997 Sam Leffler

Copyright © 1991-1997 Silicon Graphics, Inc.

Permission to use, copy, modify, distribute, and sell this software and its documentation for any purpose is hereby granted without fee, provided that (i) the above copyright notices and this permission notice appear in all copies of the software and related documentation, and (ii) the names of Sam Leffler and Silicon Graphics may not be used in any advertising or publicity relating to the software without the specific, prior written permission of Sam Leffler and Silicon Graphics.

THE SOFTWARE IS PROVIDED "AS-IS" AND WITHOUT WARRANTY OF ANY KIND, EXPRESS, IMPLIED OR OTHERWISE, INCLUDING WITHOUT LIMITATION, ANY WARRANTY OF MERCHANTABILITY OR FITNESS FOR A PARTICULAR PURPOSE.

IN NO EVENT SHALL SAM LEFFLER OR SILICON GRAPHICS BE LIABLE FOR ANY SPECIAL, INCIDENTAL, INDIRECT OR CONSEQUENTIAL DAMAGES OF ANY KIND, OR ANY DAMAGES WHATSOEVER RESULTING FROM LOSS OF USE, DATA OR PROFITS, WHETHER OR NOT

ADVISED OF THE POSSIBILITY OF DAMAGE, AND ON ANY THEORY OF LIABILITY, ARISING OUT OF OR IN CONNECTION WITH THE USE OR PERFORMANCE OF THIS SOFTWARE.

**Parent topic:** [Copyright Notice](#)

## **A Note Concerning Responsible Use of Copyrighted Materials**

Epson encourages each user to be responsible and respectful of the copyright laws when using any Epson product. While some countries' laws permit limited copying or reuse of copyrighted material in certain circumstances, those circumstances may not be as broad as some people assume. Contact your legal advisor for any questions regarding copyright law.

**Parent topic:** [Copyright Notice](#)

## **Default Delay Times for Power Management for Epson Products**

This product enters sleep mode after a period of nonuse. You can adjust the time period before power management begins, but increasing the time reduces the product's energy efficiency. Energy savings can be achieved by setting the time to sleep to a shorter interval.

**Parent topic:** [Copyright Notice](#)

## **Copyright Attribution**

© 2021 Epson America, Inc.

7/21

CPD-59881R1

**Parent topic:** [Copyright Notice](#)