

ELECTRONICTM

Servicing & Technology

JULY 1988/\$2.50

What on earth are kelvins? • The basics of static control

Simplifying electronic circuit schematics

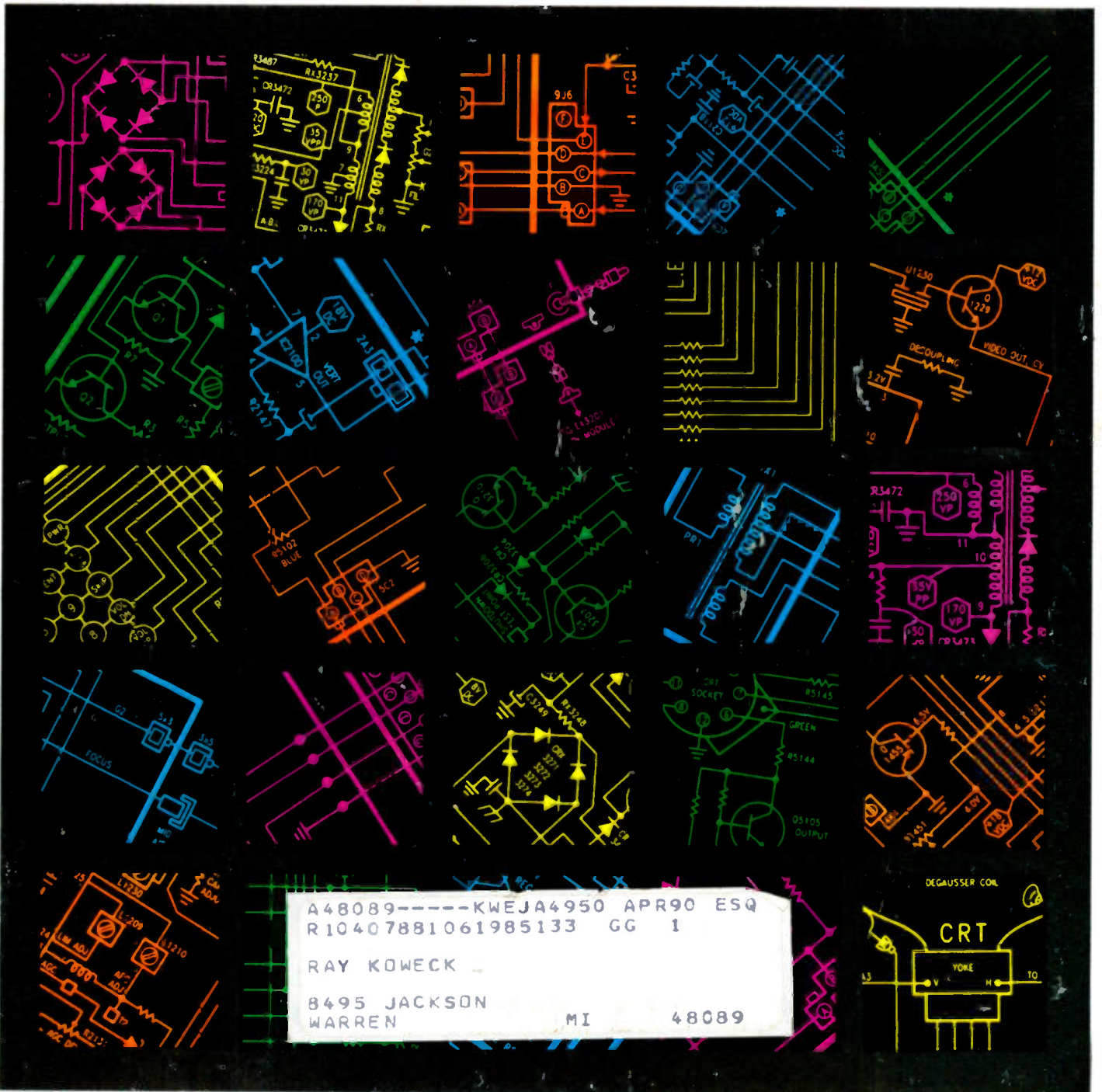

Get Your RS232C On Speaking Terms. In A Snap.

RS232C was developed to simplify communications between computers, peripherals and other electronic equipment. But what started out simple has become more complex, with different manufacturers using different cable configurations. All of which made isolating and fixing problems more time-consuming.

Beckman Industrial answers the problem with a complete line of breakout boxes that not only make locating and changing signals quick and easy, but also keeps the system communicating while you test.

Monitor 15 Lines For Less Than \$100.

The line-powered Model 725 lets you monitor the most common 15 lines including most modem communications.

Red or green LEDs make identifying positive and negative voltages easy. Dual-gender connectors make hook-up a snap. And any additional line can be monitored via jumpers to a spare set of LED monitors. Plus, its tough ABS, snap-tight case features a removable cover for added convenience. There's even an optional zippered vinyl case available.



A Breakout Box And Cable Tester In One.

Beckman Industrial makes your job twice as easy with a feature no one else offers. The Model 785 is a combination breakout box and cable tester. Its battery-powered operation allows you extra mobility and freedom while 100 LEDs allow you to fully monitor 25 lines.

Model 725 \$99.00 Breakout Box

- Monitors 15 primary data communications lines.
- Red and green LEDs identify +/- voltages.
- Includes spare Red/Green LED set.
- Jumpers included.
- Optional vinyl case available.

And, of course, it's also a full-function cable tester. With support for parallel interfaces and automatic or manual scanning of all lines. Easy-to-use faceplate voltage jacks, pulse trapping, and separate DIP switches to perform modem loopback settings are only a few of the features.

Presenting A Whole New Way To Patch.

To keep your RS232C and RS449 communications on speaking terms and make signal emulation easy,

Beckman Industrial has devised a system that lets you custom-build patch boxes right in the field. Another first from Beckman Industrial to make your job easier. Try the Model 701 Quadverter to solve printer interface problems, or the Model 702 Quad II to make patching RS232C to RS449 simple and quick.

Better yet, build your own patch system with the Model 703 Easy PATCH™ Patching



Model 785 \$345.00 Breakout Box & Cable Tester

- 100 battery-powered LEDs.
- Full-function RS232C cable tester scans all lines.
- Signal emulation via faceplate voltage jumpering.
- Pin 2 to pin 3 crossover switching.
- 2 μsec signal pulse trap.

System. Just pick any combination of 15 different connector modules included in the kit, install it in the 703 case and snap on the cover. It's that simple.

With such versatility, you can leave an Easy PATCH in the line to keep vital data communications going while you repair a bad connector or cable.

Visit your local distributor today for Beckman Industrial's data communications test equipment. Or write for a free eight-page brochure.

And keep your lines of communication open.

Beckman Industrial™

Beckman Industrial Corporation
Instrumentation Products Division
A Subsidiary of Emerson Electric Company
3883 Ruffin Road, San Diego, CA 92123-1898
(619) 495-3200 • FAX (619) 268-0172 • TLX 249031

In Service Instruments, We're The One.



SEEK PROFESSIONAL HELP

Servicing electronic equipment isn't always easy, especially if you're doing it in the field. At Chemtronics we can help with over 200 specially engineered products for the maintenance, repair and production of high technology equipment. Call today for our latest problem solving catalog.

Circle (3) on Reply Card

 **Chemtronics**
Keeping pace with advanced technology

Chemtronics, Inc. 681 Old Willets Path, Hauppauge, NY 11788 800-645-5244 In NY 516-582-3322 Telex 968567

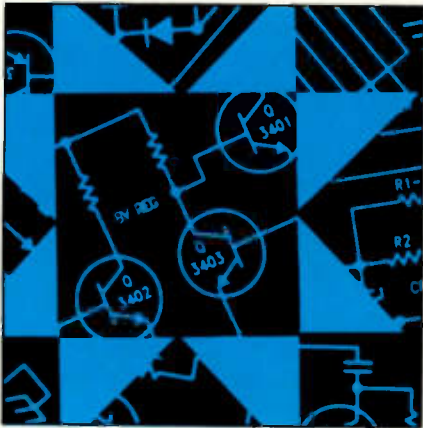

Page 8

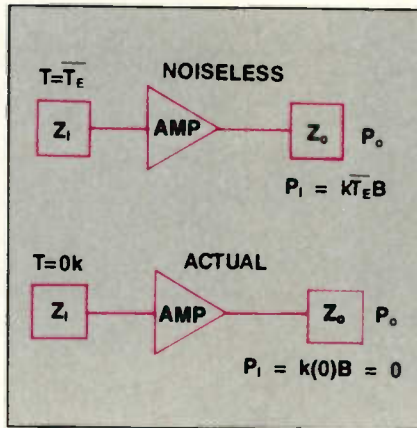

Page 22



Page 44

FEATURES

8 Simplifying electronic circuit schematics

By Robert G. Mousseau

Sometimes reading a circuit schematic is a lot more complicated than it needs to be. If you could just simplify the schematic and restructure it the way you are used to seeing it, you might suddenly see how the circuit really works. The secret is to extract just the part you need to consider. When the unnecessary distractions are removed, the circuit can suddenly seem a lot more familiar and understandable.

22 What on earth are kelvins?

By James E. Kluge

The object of a TVRO system is pretty simple—maximize the desired signals and minimize the noise. But how does a unit of temperature, the kelvin, define the noise level of an antenna system? Understanding how temperature and noise relate can help you understand how the TVRO system works.

44 The basics of static control

By Mike Voss

You know static is annoying when you zap yourself reaching for the volume knob of your stereo, but did you ever stop to consider what it does to the *stereo*? When servicing an electronics product full of static-sensitive components, the last thing you want to do is create more problems. One sure way to avoid many of those problems is to follow some basic rules for static control.

54 Products

58 Troubleshooting tips

60 Audio corner

Some basics about frequency response

62 Video corner

The 2 million-pixel CCD image sensor

64 Computer corner

Interfacing computers to the analog world—Part II

66 Readers' exchange

68 Advertisers' index

DEPARTMENTS

4 Editorial

Curing the electronics "germ"

6 News

19 Syncure

20 Books

31 Profax

42 Test your electronics knowledge

43 Literature

48 What do you know about electronics?

Modulating pulses

ON THE COVER

Looking at a manufacturer's schematic diagram can be very trying—circuit modifiers, symbols and wiring can be distracting; the schematics might be poorly drawn; the writing may be illegible. Yet these tools of the electronics servicers' trade contain information vital to understanding electronics products. (Concept and design by Barbara Miles, graphic designer.)

The how-to magazine of electronics...

ELECTRONIC
Servicing & Technology

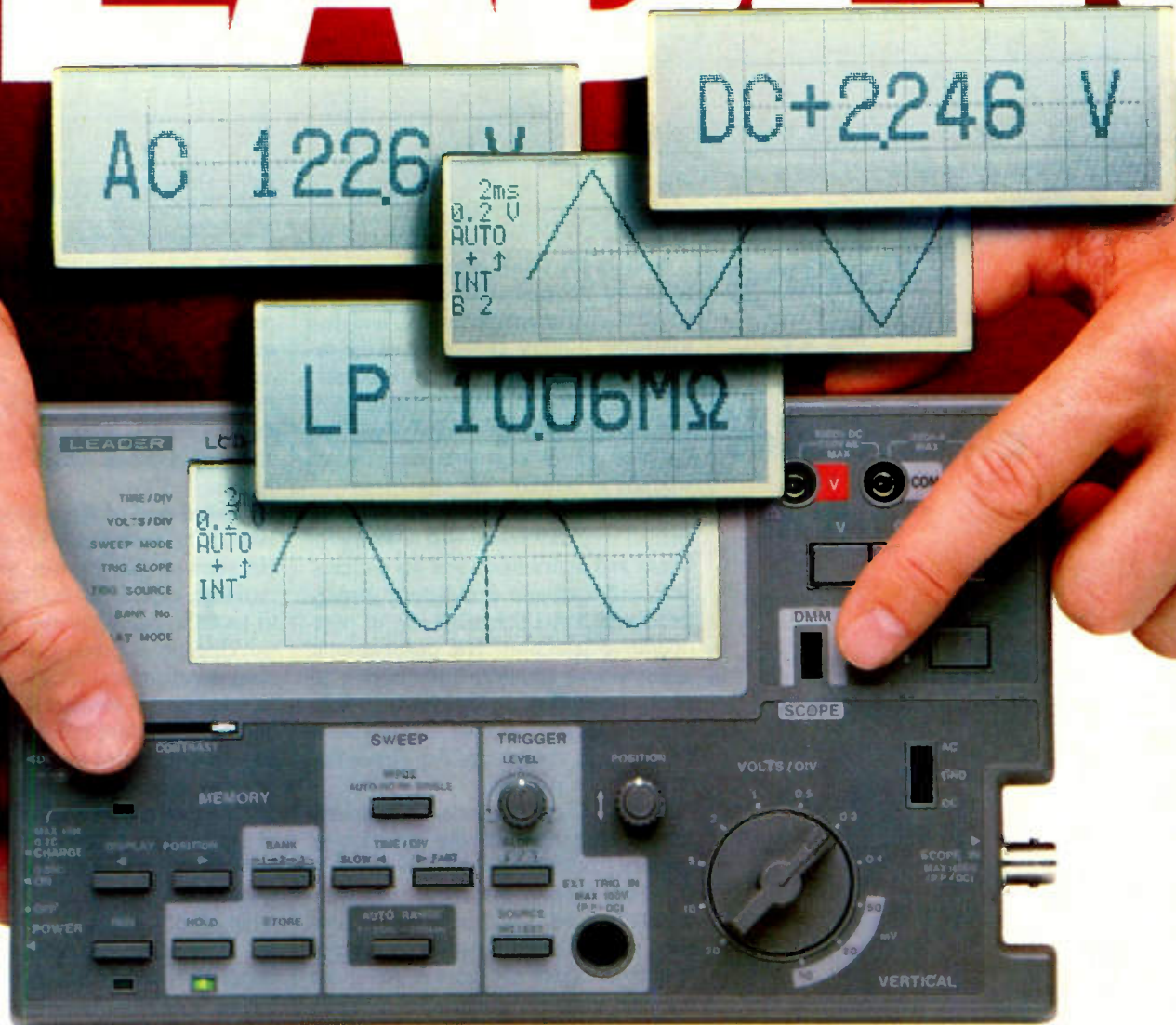

Portable Problem Solver

Ultra-compact Digital Storage Oscilloscope-Multimeter.

Easily carried in a tool kit or attache case—powered by batteries or supplied ac adaptor—this 2-in-1 lightweight is always ready for hand-held action.

Multi-function, 200-kHz DSO.

Just flip the switch from DMM to SCOPE and the performance of a professional Digital Storage Oscilloscope is at your fingertips. Lets you capture and analyze single-shot and very slow phenomena. Stores up to three waveforms, and has such top-of-the-line features as auto-ranging time base setting, pre-trigger, roll mode, and on-screen readout of setting conditions. Low-power indicator

alerts you when batteries need recharging, while a separate back-up system protects memory.

Full-function, 3½-digit DMM.

Precise measurement of ac/dc voltage, current and resistance is easy to see on the large, high-contrast, display. Automatically selects range which provides greatest accuracy and resolution.

Perfect for many applications.

LCD-100 is a unique combination instrument that can confirm that its DMM is measuring a desired signal. Better by far than a DMM alone... more useful in the field than any benchtop DSO in this bandwidth, LCD-100 is ideal for servic-

ing a broad range of electromechanical, electrical and electronic systems.

Call toll-free
1-800-645-5104

In NY State
(516) 231-6900

Ask for an evaluation unit, our latest Catalog, more information, or the name of your "Select" Leader Distributor.

For professionals
who know
the
difference.

LEADER
Instruments

380 Oser Avenue, Hauppauge, New York 11788

Regional Offices:
Chicago, Dallas, Los Angeles, Boston, Atlanta
In Canada call Omnitronix Ltd. (416) 828-6221

For information Circle (4) on Reply Card
For Demonstration Circle (5) on Reply Card

Curing the electronics "germ"

Back in the 1800s, surgery was a last resort in the treatment of disease because many patients became ill and died following surgery. In fact, all of the patients in a surgical ward frequently would die. The culprit in these diseases was thought to be some kind of gas that lingered about hospitals and caused wounds to putrefy.

In 1865, Dr. Joseph Lister, the great British surgeon, found that soaking his hands and instruments and his patients' skin with carbolic acid before surgery greatly reduced the incidence of post-operative infection. His observations, along with some information from a paper by Louis Pasteur, led him to the conclusion that microbes were responsible for decay in wounds and for illness and death in the patients.

In 1867, Lister published "On the antiseptic principle in the practice of surgery," but because of opposition to the germ theory, his revelations were widely ignored. Lister persevered, however, and his determination, combined with evidence of his success, led to the ultimate adoption of antiseptic surgery.

Of course, TVs, VCRs and computers aren't people, and the problem of causing damage in an electronic device can't be compared with the magnitude of the problem of causing a deadly infection in a hospital patient. Still, no one would want to be responsible for causing a major problem while attempting to fix a minor problem.

Unfortunately, in much of the electronics servicing industry, we seem to be at about the point medicine was at in 1867. Electronic products that are brought into the shop with minor problems are sometimes suffering major damage because the servicing technician is not taking the necessary precautions to prevent electrostatic discharge (ESD) damage.

I recently visited a number of electronics servicing facilities, and in many cases ESD protection was conspicuous by its absence. I really can't remember seeing a single wrist strap, static dissi-

pative mat or antistatic plastic bag.

We have identified the "germ" that causes "postoperative" problems in modern electronics products, but because ESD is invisible in many cases (just as the microbes were in Dr. Lister's day), it's easy to ignore it or even to chalk up damage caused by it to other causes.

I asked one of the servicing technicians if he took any ESD precautions. He showed that he was aware of the problem, explaining that he was careful to touch a ground at the bench before working on a product that contained static-sensitive devices. He is to be commended for his awareness and concern, but this procedure is not sufficient. Today, an electronics servicing technician wearing synthetic materials on a cold, dry day can generate thousands of volts of electrostatic charge just making the normal motions used in servicing an electronics product. Ripping the plastic wrap off of a snack package or a package of cigarettes can result in both damaging electrostatic fields and potential for electrostatic discharge damage.

The only way to properly guard against ESD damage is to employ products and procedures that have been developed to prevent the problem. That means placing products on grounded, static-dissipative mats; wearing grounding wrist straps; being careful about what you put on the bench, especially plastic materials that might carry a charge; and possibly even using an ionizer, which helps to dissipate static electricity.

Germs are a concept that we're all familiar with today, even if we can't see them. We routinely wash our hands and take other disease-preventive measures. ESD is a concept that electronic servicing technicians have to get used to, and they should take preventive measures to avoid causing damage to the very equipment they're trying to fix.

Nile Conrad Peram



PHILIPS



Introducing a whole new way to look at oscilloscopes.

Operation that's instinctively, unbelievably clear. Information that's detailed, yet free of errors. And intelligence that will speed your work. Philips' micro-computer controlled medium-frequency Smart Series. They could change forever the way you look at oscilloscopes.

HIGH PERFORMANCE WITH A VIEW

- **LCD window.** Large digital indications note all selected functions, instrument settings and parameter values. Instantly. Precisely. With no mistakes. And right where you need them—next to the CRT. Not hidden in crowded frontpanels. Not wasting critical waveform display area. It's a revolutionary idea that facilitates the use of an oscilloscope like nothing else. And it's only from Philips. Once again.
- **16kV CRT.** Higher acceleration voltage and advanced electron optics assure brilliance and spot quality that outshines anything else in this class.
- **Pushbutton simplicity.** Quick, one-function buttons have replaced knobs for faster, surer, more reliable operation.

- **Instant-action AUTOSET.** Philips' intelligent beamfinder automatically selects channel, amplitude, timebase and triggering for error-free display of any input signal. Great for troubleshooting!
- **"Clever" cursors and delayed sweep.** Standard on the PM 3070, "clever" cursors supply immediate amplitude and timing measurements with direct CRT readout. And an exclusive cursor-operated ZOOM function offers the most efficient use of delayed sweep available in analog scopes.
- **Auto-Triggering intelligence.** Provides fast, stable triggering up to 150 MHz.
- **Probefactor compensation in LCD.** It automatically adjusts all readouts for the probe you're using.
- **IEEE compatibility.** For fast computer hook-up and automated production test and calibration.
- **Choice of four models:** Single and dual timebase; 60 or 100 MHz bandwidths.

SUPPORTING VIEW

Philips' medium-frequency instruments come with a 3-year warranty, a 30-day money-back guarantee and all the tech-

nical and service assistance you need. From Fluke—the people who believe that extraordinary technology deserves extraordinary support.

POINT OF VIEW

Call Fluke today at **800-44-FLUKE ext. 77**. And find out how easy it is to change the way you look at oscilloscopes.

Ask for your free copy of our new guidebook, Basic Principles of Oscilloscopes.

John Fluke Mfg. Co., Inc., P.O. Box C9090, M/S 250C, Everett, WA 98206
U.S.: 206-356-5400 CANADA: 416-890-7600
OTHER COUNTRIES: 206-356-5500

© Copyright 1988 John Fluke Mfg. Co., Inc.
All rights reserved. Ad No. 0481-P3065/70

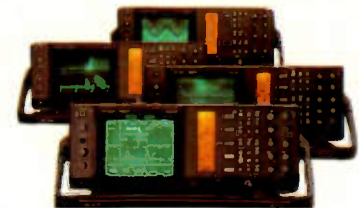

SMART SERIES OSCILLOSCOPES • 60 & 100 MHz



Circle (6) on Reply Card

Seminar schedule set for NPEC show

The seminar line-up for the 1988 National Professional Electronics Convention will include classes for both advanced electronics servicers and for newcomers. The convention, to be held Aug. 1-6 at the Pheasant Run Resort in St. Charles, IL, will include a CD school, sponsored by the Electronics Industry Association/Consumer Electronics Group and presented by Elmer Poe, CET. The 2-day school will be offered all day on either Tuesday and Wednesday or Friday and Saturday. Because of the hands-on nature of the class, schools will have limited enrollment.

On Saturday, Toshiba America and Sony will offer courses for more advanced servicers. Toshiba will conduct an advanced Super VHS VCR and camcorder movie seminar. Sony will offer a class on the principles and operation of DAT. Other technical seminars include an all-day Tuesday session on chroma and luminescence noise-reduction circuits in digital VCRs (sponsored by NEC Electronics) and, on Friday, a seminar on how to analyze, identify and resolve interference, presented by Colleen McNeely, FCC public affairs specialist.

For more information, write NPEC '88, 2708 W. Berry St., Fort Worth, TX 76109, or call 817-921-9061.

ETA presents award

The Professional Electronics Technicians Association (ETA) presented the 1988 Technician of the Year Award to Marion N. Amos, Sr., CET, a retired U.S. Army captain who is currently an instructor of electronics technology at the Electronic Computer Programming Institute (ECPI) in Virginia Beach, VA. Mr. Amos was also elected chairman of ETA's certified technicians division, which qualifies him as a member of the ETA-I Board of Directors. He also has initiated a student chapter of ETA at the ECPI.

U.S. factory sales rise 16% in first quarter

U.S. factory shipments of electronic equipment, components and related products (excluding imports) totaled \$62.2 billion for the first quarter of 1988, a 16% increase over the 1987 first quarter total industry sales figure of \$53.5 billion, according to the Electronic Industries Association (EIA). The

EIA cites a combination of factors, including the replenishment of low year-end inventories, increased interest in electronics products, and the positive performance of the nation's economy as a whole as reasons for the increase. Specific areas of increase include:

- Electronic components shipments totaled \$11.8 billion, up approximately 23% from 1987's total of \$9.6 billion.
- The consumer electronics sector registered almost \$1.6 billion, up more than 18% over last year's \$21.4 billion.
- Computers and industrial electronics sales rose to \$21.4 billion, a 22% increase over last year's \$17.6 billion.
- The communications equipment sector's first-quarter sales increased 7% over last year's \$14.7 billion to this year's \$15.8 billion.
- Sales of other electronics-related products and services totaled almost \$11.6 billion in 1988, up 11% over 1987's \$10.4 billion.

EIA publishes code booklet

The Electronic Industries Association's engineering department has published the 1988 *Source Code and Date Code Booklet*. The booklet, which is published annually, contains an alphabetical and numerical listing of code numbers that are stamped on electronic products to identify production sources or the vendor assuming responsibility. The EIA code also allows the servicer to add numerals to the source code symbol to identify the year and week of production. Cost for the booklet is \$1. The source code and date code service is available to all manufacturers of electronic equipment and components for an annual registration fee of \$30. EIA members receive the service free. Contact the EIA at 2001 Eye St. N.W., Washington, DC 20006; 202-457-4981.

UL revises catalog

Underwriters Laboratories has revised its catalog to include alphabetical listings of standards arranged by key words. (For example, the standard for "tin-clad fire doors" will appear under tin-clad, doors and fire doors.) The catalog includes more than 100 revisions and new sets of standards that cover the standards of each of UL's six engineering departments. The free catalog can be requested from UL's Publication Stock at 333 Pfingsten Road, Northbrook, IL 60062.

The how-to magazine of electronics

ELECTRONIC

Servicing & Technology

Electronic Servicing & Technology is the "how-to" magazine for technicians who service consumer electronics equipment. This includes service technicians, field service personnel and avid servicing enthusiasts who repair and maintain audio, video, computer and other consumer electronics equipment.

EDITORIAL

Nils Conrad Persson, *Editor*
 Carl Babcoke, *Consumer Servicing Consultant*
 Tom Cook, *Senior Managing Editor*
 Alisa Carter, *Associate Editor*
 Kathy Mickelson, *Editorial Assistant*
 James McWard, *Editorial Assistant*

CONSULTING EDITORS

Homer L. Davidson, *TV Servicing Consultant*
 Christopher H. Fenton, *Circuit Fabrication Consultant*
 Victor Meeldijk, *Components Consultant*
 Kirk G. Vistain, *Audio Consultant*
 Sam Wilson, *Electronics Theory Consultant*

ART

Kevin Callahan, *Creative Director*
 Barbara Miles, *Graphic Designer*

BUSINESS

Cameron Bishop, *Group Vice President*
 Eric Jacobson, *Publisher*
 Greg Garrison, *Sales Manager*
 Stephanie Hanaway, *Promotions Manager*
 Kelly Hawthorne, *Promotions Coordinator*
 Dee Unger, *Advertising Business Manager*
 Catherine Grawe, *Advertising Coordinator*

ADVERTISING

Regional advertising sales offices are listed in classified pages.

ADMINISTRATION

R. J. Hancock, *President*
 Doug Riemer, *Circulation Vice President*
 Jane J. Powell, *Circulation Director*
 Jo Ann DeSmet, *Fulfillment Manager*
 Barbara Clare, *Reader Correspondent*



Member, Audit Bureau of Circulation



Member, American Business Press



Member, Electronic Servicing Dealers Association

CORRESPONDENCE

Editorial, advertising and circulation correspondence should be addressed to: P.O. Box 12901, Overland Park, KS 66212-9981 (a suburb of Kansas City, MO); 913-888-4664. Home office fax: 913-888-7243. Home office telex: 42-4156 INTERTEC OLPK

SUBSCRIPTION PRICES: one year, \$19.49; two years, \$32.98 in the USA and its possessions. Foreign countries: one year, \$23.49; two years, \$36.98. Single copy price: \$2.50; back copies, \$3.00. Adjustment necessitated by subscription termination to single copy rate. Allow 6 to 8 weeks for new subscriptions.

PHOTOCOPY RIGHTS: Permission to photocopy for internal or personal use is granted by Intertec Publishing Corp. for libraries and others registered with Copyright Clearance Center (CCC), provided the base fee of \$2 per copy of article is paid directly to CCC, 21 Congress St., Salem, MA 01970. Special requests should be addressed to Eric Jacobson, publisher. ISSN 0278-9922 \$2.00 + 0.00

INTERTEC
 PUBLISHING CORPORATION

© 1988 All rights reserved.

ES&T

Put them to the test

Mini-Meters with Maxi-Specs

5" L x 2 1/4" W x 1 1/8" H 5 1/2" L x 2 1/4" W x 3/4" H 5 3/4" L x 2 1/8" W x 1 1/8" H



SCOPE 3 1/2 Digit LCD Meter

- 0.5% Accuracy • DC Voltage • AC Voltage • DC Current • Resistance • Diode Test • Battery Life 300 Hrs. • Overload Protection: DC 500V, AC 350V, ohms 250V DC/AC.

Model DVM-630

Our Price **\$2995**
Zippered carrying case CC-30 \$4.50

NEW! SCOPE 3 1/2 Digit, LCD 8 Function w/ Transistor Tester

- 0.5% Accuracy • Audible continuity and diode test • 10 Amp measurement • Resistance • DC/AC Voltage.

Model DYM-632

Reg. \$60.00
Our Price **\$4495**
Zippered carrying case CC-30 \$4.50

SCOPE 3 1/2 Digit LCD w/ Autoranging

- 0.5% Accuracy • Auto/Manual range selection • DC Voltage • AC Voltage • AC Current • DC Current • Resistance.

Model DYM-631

Our Price **\$4995**
Deluxe carrying case CA-92 \$9.95

Special

SCOPE Digital Capacitance Meter

.1 pf to 2000 µf



- Digital LCD display • LSI-circuit • High accuracy: 100 PPM 0.5% • Broad test range • Fast sampling time • Capacitor discharge protection • Compact, lightweight design • One-hand operation.

Model DCM-602

Our Price **\$5995**

SCOPE Digital Multimeters

- Overload protection • Auto-decimal LCD readout • Polarity indication • 300 hr. 9V battery life • Low battery indicator • 5% DC accuracy

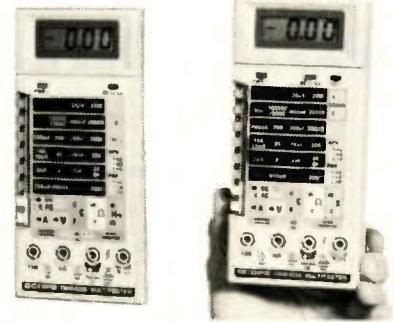

- 8 Functions, 37 Ranges Including Transistor and Capacitance measurements

Model DVM-636

Our Price **\$6750**

- 11 Function, 38 ranges including Logic Level Detector, Audible and Visual Continuity, Capacitance and Conductance measurements

Model DVM-638

Our Price **\$8750**

CA-92 Deluxe Padded Case for DVM meters \$9.95
TL-216 Transistor and Capacitance Test Leads \$9.90



NEW!

SCOPE Frequency Counters

- 8-digit LED • Compact • light-weight • Automatic range and Hold function • High stability in reference oscillator.

Model FC-7011

100 MHz Our Price **\$16995**

Model FC-7051

550 MHz Our Price **\$24995**



FORDHAM Frequency Counter

- 10 Hz - 150 MHz Range • 7-digit LED display • VHF/HF selection • Gate time 1 sec., 5 sec. • ±1 count accuracy.

Model FC-150

Our Price **\$13990**



NEW

FORDHAM Function Generator

- 0.5 Hz - 500 KHz in 6 ranges • Sine, square & triangle wave forms • VCA and VCF inputs • Accuracy ±5% of full scale.

Model FG-202

Our Price **\$14990**

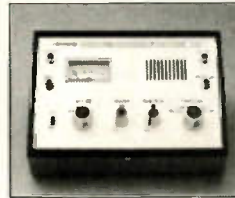

FORDHAM Signal Tracer/Injector

- Easy to operate • VU meter • Two LED mode indicators • 1 KHz test tone • 8 ohm speaker • Test leads.

Model SE-610

Our Price **\$11990**



FORDHAM LCR Bridge Meter

- Fully transistorized • 1 KHz signal generator • Measures resistance, inductance, capacitance • High mechanical and electrical stability • Battery operated.

Model LC-340

Our Price **\$14995**



B&K Precision 20 MHz Dual Trace

- Dual/Single trace operation • 1 mV/div sensitivity • Auto/Normal triggered sweep operation with AC, TVH, TVV and Line coupling • Calibrated 18 step time base with IOX magnifier.

Model 2120

Our Price **\$39995**

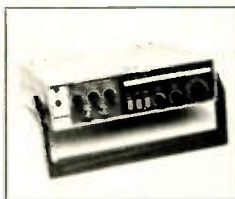

FORDHAM Sweep Function Generator

- Frequency range 0.2 Hz to 2 MHz • Sine, triangle, square, pulse TTL, wave forms • Frequency accuracy ±5% of length scale • Test leads included.

Model FG-801

Our Price **\$21995**



SCOPE 4 1/2 Digit Bench Digital Multimeter

- 4 1/2 Digit LCD • Automatic (-) negative polarity • Six 1.5V "D" size batteries • Low battery indication • Overload protection • Test lead set, batteries, spare fuse incl.

Model DVM-6005

Our Price **\$21995**



Hitachi 35 MHz Dual Trace Oscilloscope

- Frequency band width DC to 35 MHz • 6 inch CRT with % calibrations • Autofocus • Scale illumination and photographic bezel • Lightweight, compact • Probes incl.

Model V-355

Our Price **\$59995**



SCOPE Pocket Sized Audio Signal Generator

- Sine/square wave patterns • 20 Hz to 150 KHz • Battery operation • Freq. accuracy ±3% or less • Output 1.2V rms max. (no load) • Low battery indicator • Test leads / 9V battery incl.

Model RC-555

Our Price **\$5995**

Telephone Orders Now!

ASK FOR FREE CATALOG. Money orders, checks accepted. C.O.D.'s require 25% deposit

Fordham

260 Motor Parkway, Hauppauge, NY 11788

Toll Free **800-645-9518**

In NY State 800-832-1446

Mon. - Fri. 8 a.m. - 6 p.m. EST. Sat. 9 a.m. - 3 p.m. EST

Service & Shipping Charge Schedule Continental U.S.A.

FOR ORDERS	ADD
\$25-100	\$4.50
\$101-250	\$6.00
\$251-400	\$8.00
\$501-750	\$10.50
\$751-1,000	\$12.50
\$1,001-1,500	\$16.50
\$1,501-2,000	\$20.00
\$2,001 and up	\$25.00

Simplifying electronic circuit schematics

By Robert G. Mousseau

Trying to determine how a circuit works using a manufacturer's diagram or a Sams Photofact can be a difficult job. The diagram is full of distractions such as circuit modifiers, stage locations, symbols, wiring and page breaks. Manufacturers' schematics are often poorly drawn and illegibly printed. Circuits drawn in electronics texts, on the other hand, are simplified versions of these same circuits, but they are structured and simplified to reduce their complexity.

It is often easier to understand a circuit if it is extracted from the schematic, simplified and restructured to appear as it would in a familiar textbook format. Reorganizing the circuit makes it easier to understand because you have an unobstructed view of the circuit and can often recognize a component's function based on its location in a familiar format.

Mousseau is the department head of electronics at the State Technical Institute and Rehabilitation Center in Delton, MI.

If you extract a circuit for study, you should first identify which part of the diagram or circuit you wish to extract. Once the limits have been determined, extraction and simplification of the circuit can begin.

Start with an exact redraw

It is easier to extract and reorganize the circuit if you first redraw the circuit exactly as it appears on the schematic diagram. If you attempt to simplify or modify the circuit while it is being redrawn or extracted, you may introduce errors.

Figure 1a shows a partial schematic diagram. That portion of the circuit that needs to be extracted has been highlighted. Figure 1b shows the same circuit after extraction. Note that the circuit has been redrawn exactly as it appears on the diagram.

The part of the circuit we are interested in is Q_3 , in particular, the biasing arrangement. Simplification will help in determining the method of biasing and the source of bias voltage. Other

information will also become available after the circuit has been simplified, as component placement will then conform to a familiar circuit pattern.

Following extraction, the circuit should be simplified. This step is shown in Figure 1c. Remove all ac components and other circuit modifiers (to be explained later) that are non-essential to dc or basic circuit operation—this removes clutter from the diagram.

The circuit is reorganized in Figure 1d. The components are organized to appear as they would in a textbook, with the V_{CC} at the top of the sheet and the ground at the bottom. The manner in which you restructure the circuit depends on your perspective (how you see circuits) and the type of organization you favor. Whichever way it is done, restructuring should present the circuit in a familiar, understandable form. Restructuring or reorganizing the circuit can be a difficult task, depending on the complexity of the original circuit. It may be necessary to reorganize and redraw the circuit several times before the pat-

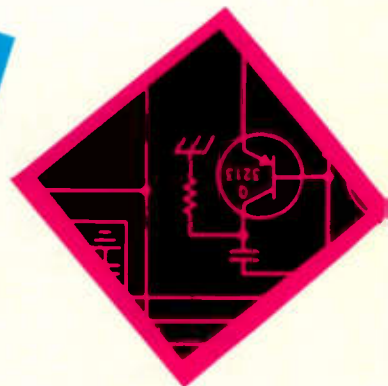

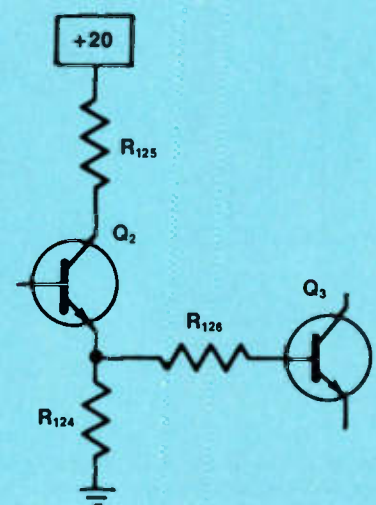
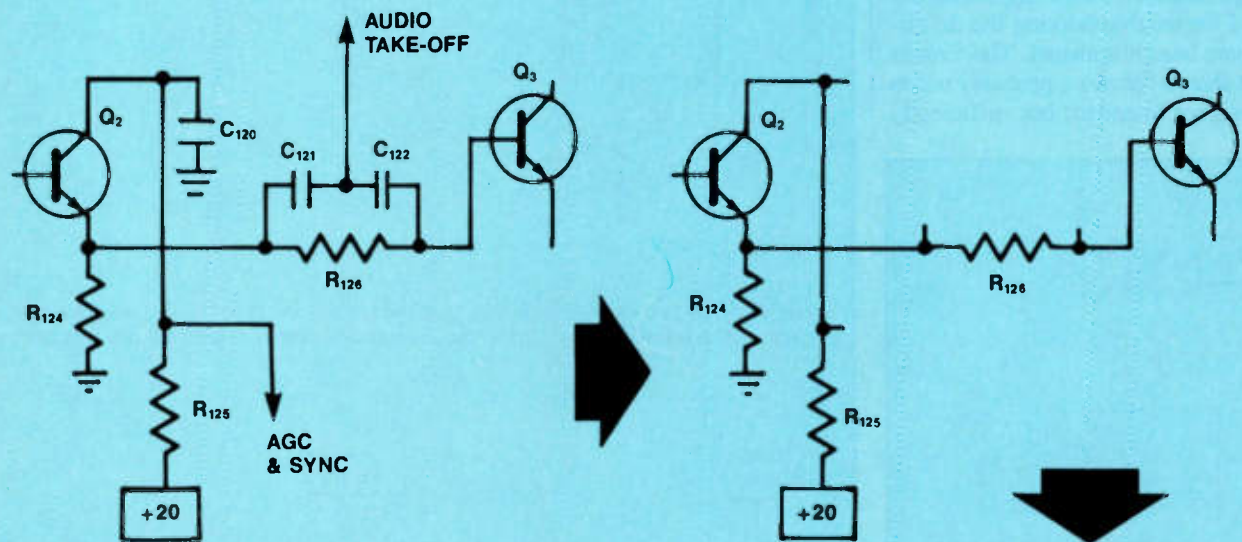
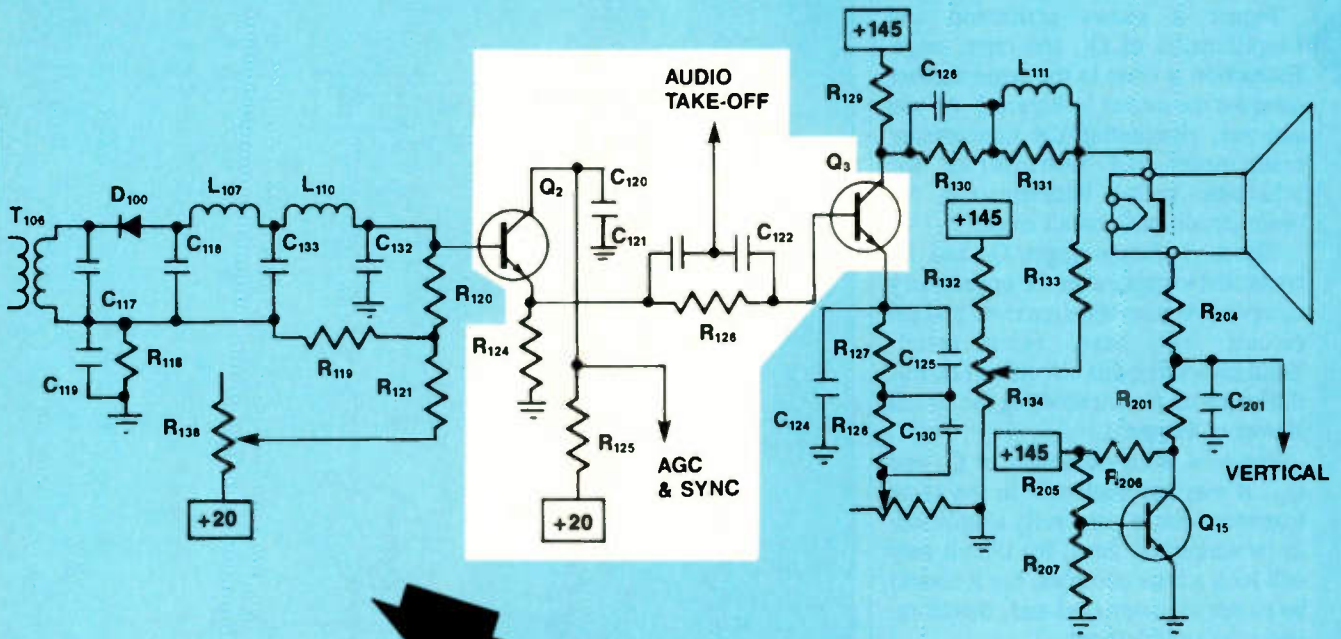
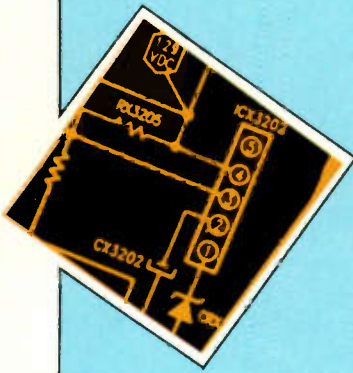

Figure 1. A manufacturer's schematic or Sams Photofact schematic contains a lot of information about a consumer electronics product. The purpose and operation of a particular segment of the circuitry is frequently obscured, however, because the circuit contains more information than you need, or is drawn in an unfamiliar orientation. You can enhance your understanding of a circuit by drawing a simplified schematic diagram in an orientation that you're comfortable with.



tern becomes understandable.

Figure 2 shows extraction and simplification of Q_2 , the input stage. Extraction is done in the same manner used for the circuit in Figure 1. As you can see, eliminating the unnecessary components and restructuring the schematic makes understanding the basic circuit path much easier.

Figure 3 shows stages Q_2 and Q_3 connected together after the unnecessary components have been removed and the circuit has been restructured. Troubleshooting this circuit will be less difficult than troubleshooting the circuit shown in Figure 1.

Figure 4 is an extraction of Q_3 and Q_{15} . It was accomplished in the same manner as those previously simplified. In its simplified form, the circuit may still look a little complex, but it should be easier to understand and, therefore, easier to troubleshoot.

Figure 5 shows the complete circuit in simplified form. All components not needed for troubleshooting the dc circuits have been eliminated. The circuits shown should function, probably not as the designer intended, but sufficiently

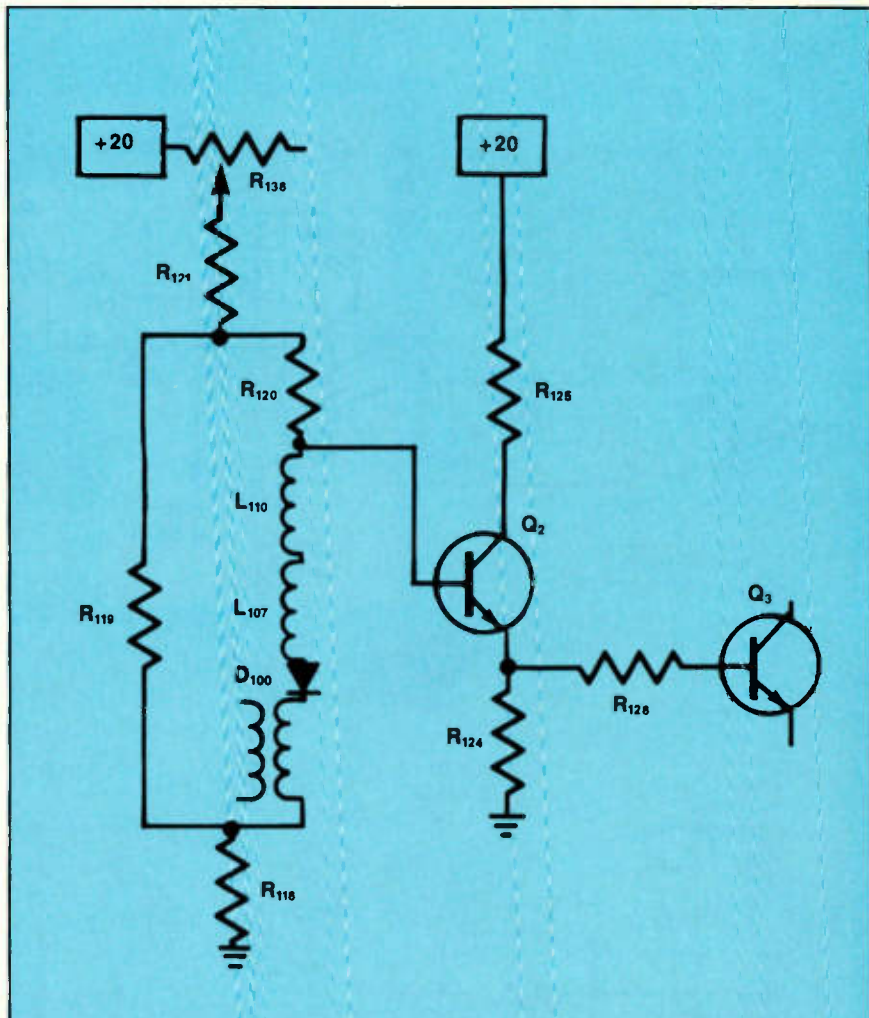
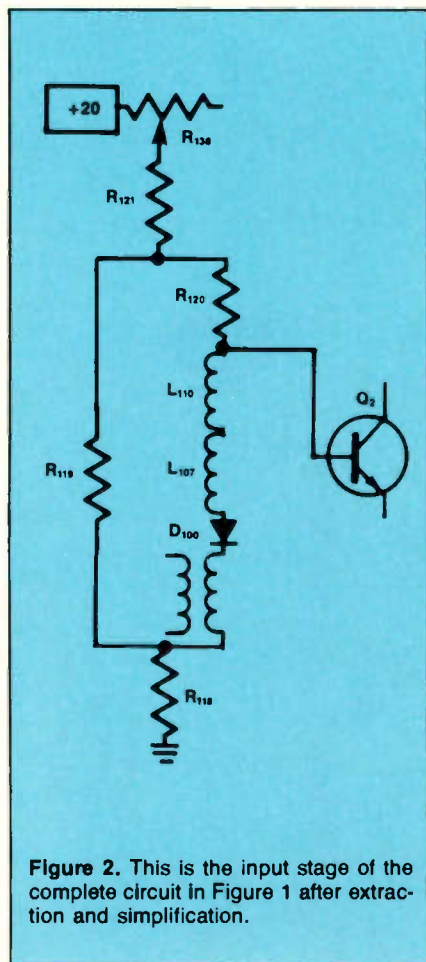

Figure 3. This figure shows the Q_2 and Q_3 stages of the circuit in Figure 1 after the components not essential to dc or basic circuit operation and restructuring are removed.

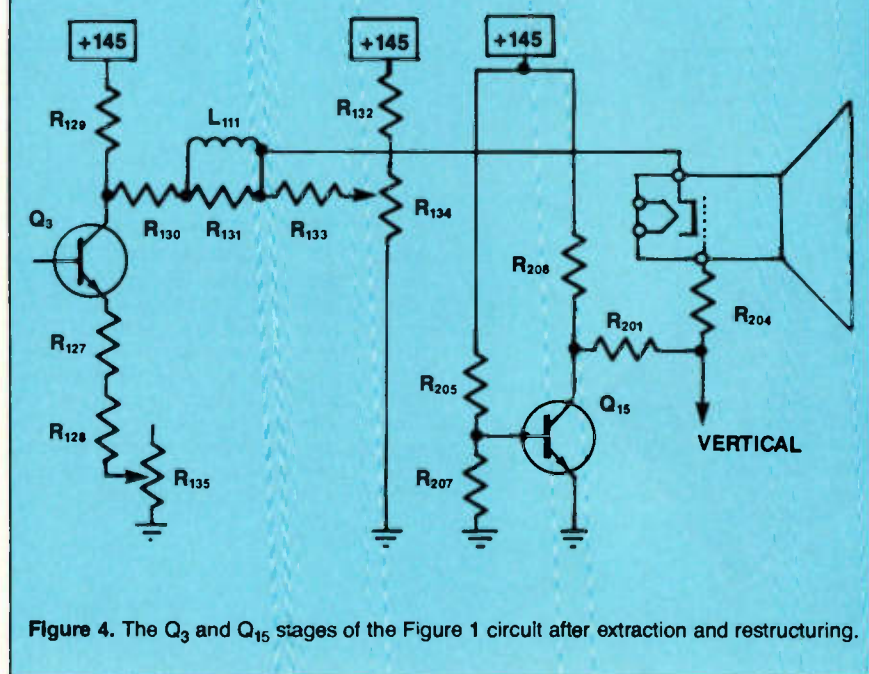
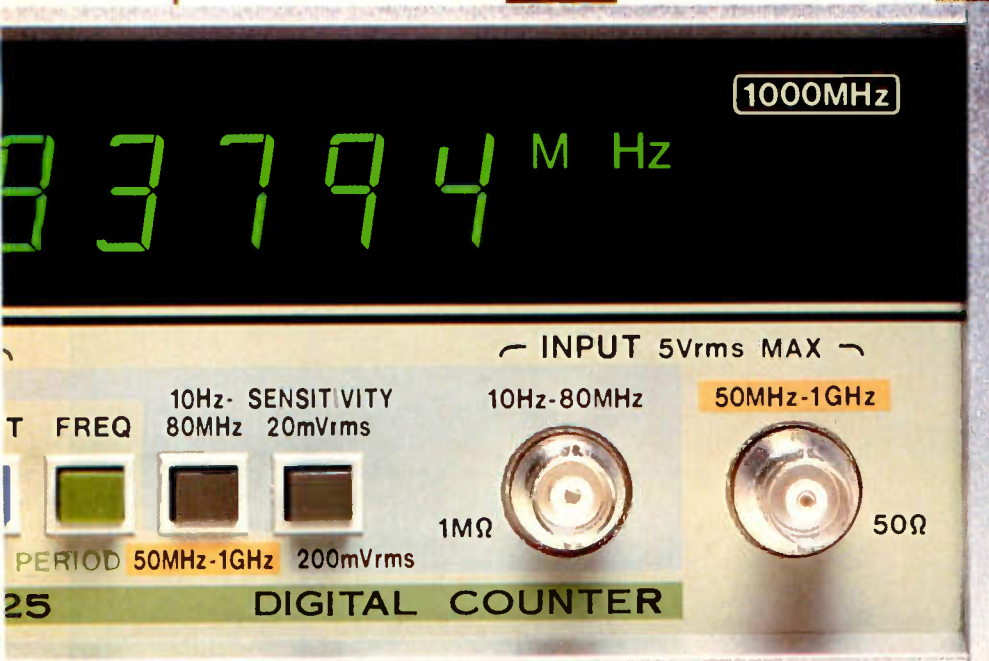

Figure 4. The Q_3 and Q_{15} stages of the Figure 1 circuit after extraction and restructuring.

LEADER



Our counters lead a shielded life.

Leader gives you virtually total protection from EMI and RFI, because Leader frequency counters come in all-metal housings. Leader also gives you remarkable accuracy and stability—our 1-GHz counter is accurate to 0.03 parts per million ± 1 digit. And that's over the entire temperature range of 0° to 40°C.

With large, bright displays, 20-mV sensitivity, and choice of gate times, Leader frequency counters are the right choice.

Built tough to endure the rigors of 3-shift production operations and the roughest handling by service technicians and students, Leader counters function perfectly under severe environmental conditions that would destroy ordinary counters.

That's why we give them two-year warranties.

See the Leader difference. Ask for our catalog, an evaluation unit and the name of your nearest "Select" Leader distributor.

LDC-825
8-digit Frequency Counter
1 GHz

ACTUAL SIZE



LDC-824S
8-digit Frequency Counter
520 MHz

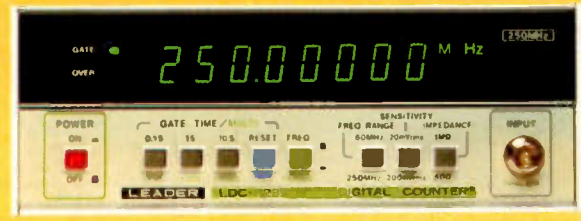

LDC-823S
8-digit Frequency Counter
250 MHz

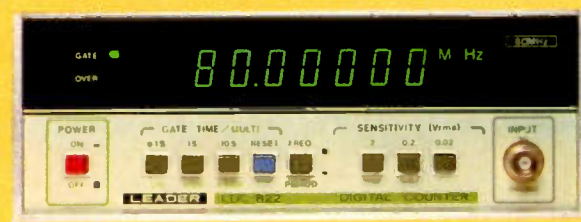

LDC-822
7-digit Frequency Counter
80 MHz

Call toll-free
(800) 645-5104
In New York State
(516) 231-6900

For professionals who know the difference.



380 Oser Avenue
Hauppauge, New York 11788
Regional Offices:
Chicago, Dallas, Los Angeles, Boston
In Canada call Omnitronix Ltd.
(514) 337-9500

For information Circle (8) on Reply Card
For Demonstration Circle (9) on Reply Card

well to determine which stage is inoperative. The problem was identified as a dc circuit problem and our effort was directed to simplifying that portion of the circuitry. Had we been interested in the signal path, a signal flow diagram would have been preferred.

Signal flow diagram

A signal flow diagram identifies the portion of the circuitry and the com-

ponents that are directly involved with signal flow. A problem requiring a signal flow diagram would involve a loss of signal or signal distortion, but the dc circuitry would not appear to be involved. A signal flow diagram is often helpful in determining test points, signal level at these points, and possible components that could affect signal flow. A signal flow diagram (see the example in Figure 6) is also less difficult to con-

struct than a simplified diagram.

This diagram shows only those components directly involved in the signal's passage from the input to the output of the circuit. For the purpose of signal tracing, injection or measurement, this diagram is much easier to follow than the diagram on the original schematic.

Modifiers

All amplifiers must have several in-

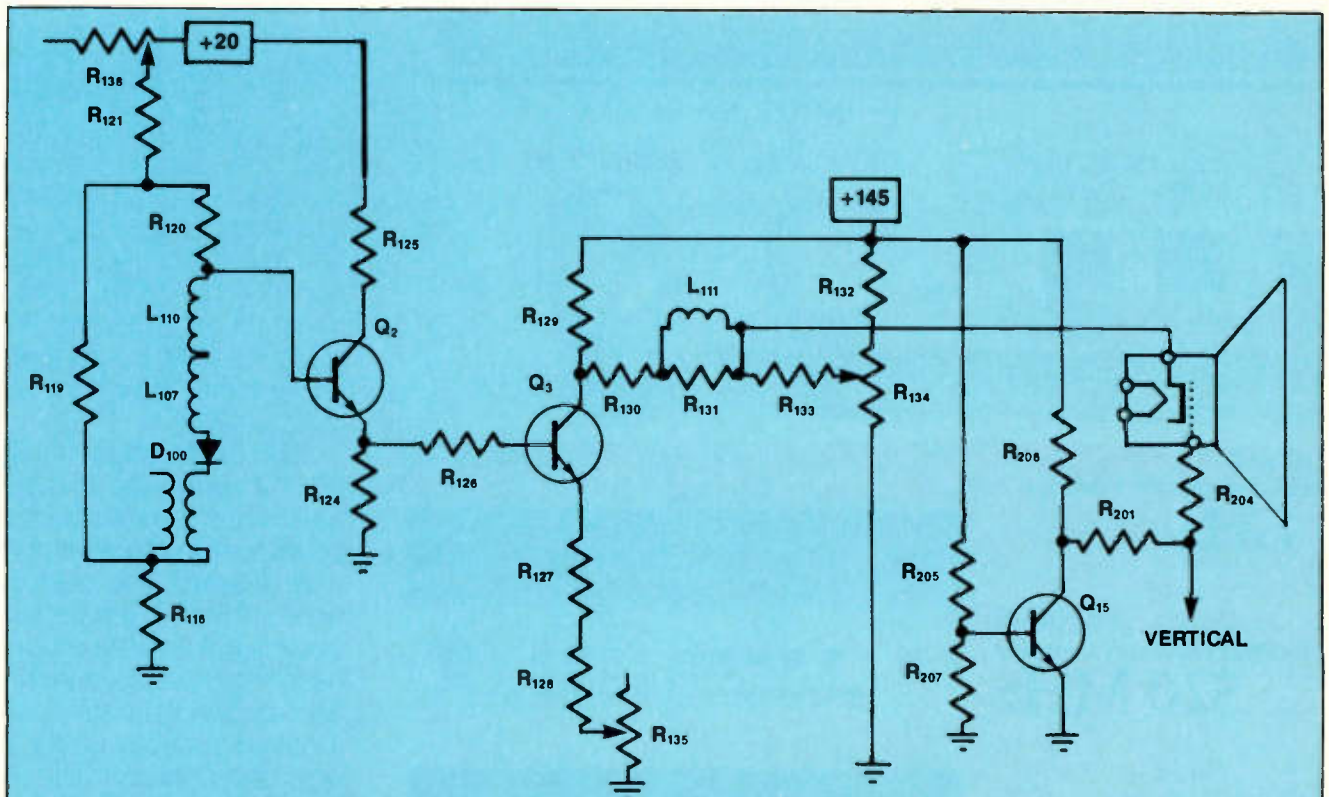

Figure 5. The complete circuit of Figure 1 simplified and restructured. Circuit operation is far easier to understand with supply voltages at the top, ground at the bottom, and portions not essential to the circuit operation (such as the audio take-off at R₂₆) eliminated.

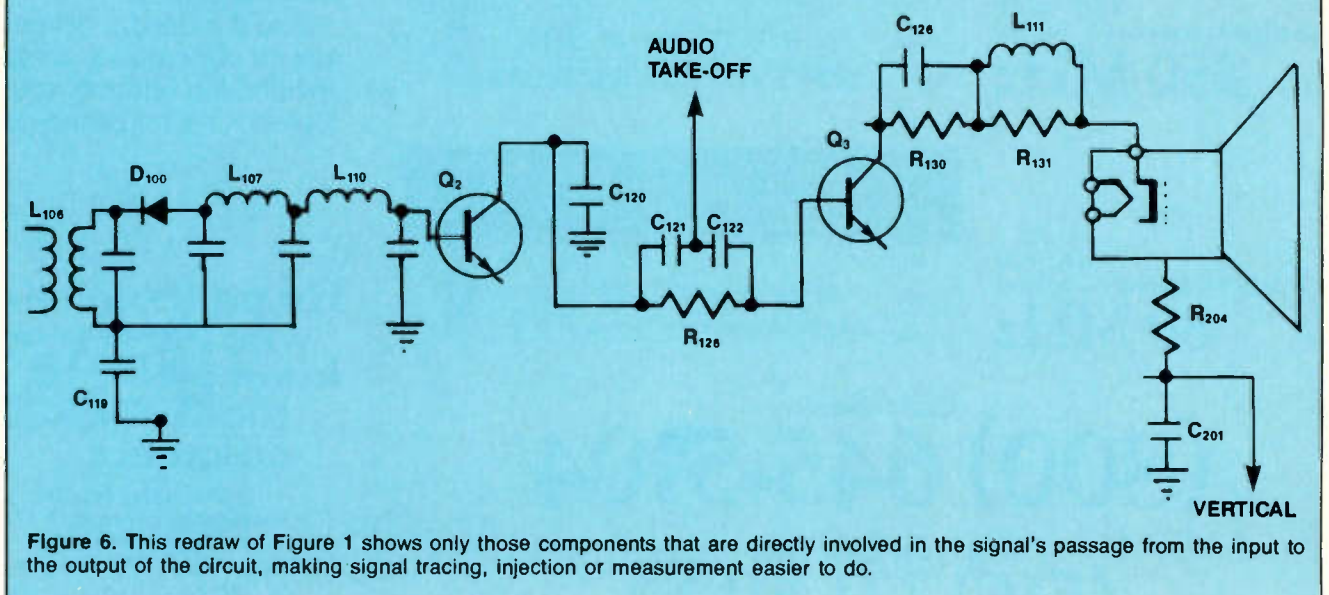

Figure 6. This redraw of Figure 1 shows only those components that are directly involved in the signal's passage from the input to the output of the circuit, making signal tracing, injection or measurement easier to do.

dividual dc circuits, such as those for biasing and current flow between ground and V_{CC} through the transistor or active device. Other components in a stage can be classified as modifiers. These components are included to modify the basic circuit and enhance operation by improving bandwidth, shaping waveforms, providing feedback and eliminating certain unwanted signals. Examples of such modifiers are C_{120} , C_{121} and C_{122} in Figure 1a. C_{120} , a 330pF capacitor, decouples unwanted frequencies to ground. C_{121} and C_{122} , both 68pF, couple a high frequency to the audio section.

These modifiers may be removed from the schematic diagram for either troubleshooting or circuit simplification. When removed, the modifiers will not prevent a stage from operating. They will, however, affect the designed stage operation. For example, eliminating a feedback capacitor can cause the stage to oscillate; removing a bypass capacitor can reduce gain. Removing modifiers also can affect bandwidth, waveshaping and more. You should understand the

function of the component you remove and the effect it will have on subsequent circuit operation, or the circuit changes may influence your decision concerning the problem or your troubleshooting approach.

When evaluating modifiers, you should keep certain facts in mind:

- Low-value capacitors pass high frequencies and block low frequencies. Large or high-value capacitors pass all frequencies above a specific frequency. The larger the capacitor value, the lower the frequency passed.
- Inductors block high frequencies and pass low frequencies. The higher the reactance, the lower the frequency blocked.
- Capacitors and inductors, either in series or parallel, form a resonant circuit at some frequency.
- An inductor, by virtue of its distributed capacitance, is resonant at some frequency.
- If the bias on a stage is below cutoff when a signal is applied or in normal operation, a capacitive clamp is most likely involved.

- A resistor placed in parallel with a coil damps oscillations.
- A diode across a coil suppresses induced voltage spikes.
- A capacitor to ground is usually a decoupling capacitor removing an undesired ac signal from the circuit.

Although these tips are generalized and may not be self-evident, they are sufficiently standard that they can be used as a guide in understanding the function of components in a circuit.

Capacitors are used primarily for six purposes: coupling, decoupling, bypass, waveshaping, clamping (biasing) and forming resonant circuits. How often capacitors are used also may be in that order.

Note that in some texts, bypass and decoupling capacitors are both identified as bypass capacitors. For purposes of this article, a bypass capacitor routes the signal around a component or circuit but does not remove the signal from the signal path. The signal will be

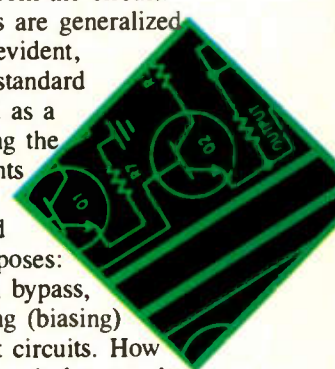

GUARANTEED PERFORMANCE!!



METERS



- 73 3 1/2" digit, DMM \$67
- 75 3 1/2" digit, DMM 99.
- 77 3 1/2" digit, DMM 128
- 8060A 4 1/2" digit-true RMS 323.
- 8062A 4 1/2" digit-true RMS 260.
- 37 Bench/portable DMM 217.
- 8010A Bench/portable true RMS 255.
- 8012A Bench/portable true RMS 318.
- 8050A Bench/portable true RMS 349.

FULL LINE AVAILABLE
BECKMAN
Beckman Industrial

- DM15B 3 1/2" digit, 26 ranges, beeper \$51.98
- DM25L 3 1/2" digit, 29 ranges, logic probe, cap measure 94.50
- DM850 4 1/2" digit, frequency counter, data hold 207.83
- Tech300 Diode Test 113.00
- Tech330 True RMS, Diode Test 206.00
- DM73 Probe-Auto-ranging, beeper, data hold 55.00
- CC6 Clamp-on meters (measure up to 600 amps) 68.18
- DM10 3 1/2" digit 38.00

SCOPES



3 Years
Manufacturers
Warranty
parts & labor

HITACHI **Special**

- V-212 20 MHz dual trace scope \$385
- V-222 20 MHz dual trace scope 550.
- V-423 40 MHz dual trace, delayed sweep scope 795.
- V-660 60 MHz dual trace scope 999.
- V-665 60 MHz dual trace/cursor readout scope 1245.
- V-1060 100 MHz dual trace scope 1294.
- V-1065 100 MHz cursor readout scope 1544.
- V-6020 20 MHz digital storage scope 1745.

Beckman
9020 20 MHz dual trace scope, component tester, delay sweep \$495

B&K
2120 20 MHz dual trace scope 455

IWATSU

- DS-6411 40 MHz digital storage scope Call For Prices
- DS-6612 60 MHz digital storage scope
- SS-5706 30 MHz 3 channel scope

POWER SUPPLIES

- SS-5705 40 MHz 3 channel scope Iwatsu
- SS-5710 60 MHz 4 channel scope Call For Prices
- SS-5712 200 MHz 4 channel scope
- SS-6122 100 MHz 4 channel scope/CRT readout & cursor

Viz

- WP-702A Dual 0-20VDC (0-200MA, dual meter) \$190.
- WP-703A Single 0-20VDC (0-500MA, single meter) 146.
- WP-704A Single 0-40VDC (0-250MA, single meter) 146.
- WP-705A Single 0-50VDC (0-2A, digital meter) 349.
- WP-706A Single 0-25VDC (0-4A, digital meter) 370.
- WP-707A Dual 0-25VDC (0-2A, digital meter) 465.
- WP-31A Isolation transformer 1.5KVA, 3 fixed 350VA outputs 223.78

B&K

- 1610 Power supply 0-30VDC, 0-1A \$147.
- 1630 Power supply 0-30VDC, 0-3A 220.
- 3011 Function generator 0.2 Hz - 2MHz 205.

IC TESTER

B&K

- 560 Programmable IC tester \$2970.
- 541 Component tester 354
- 550 T.T.L. IC comparator 364.
- 552 CMOS I.C. comparator 364.

SOLDERING SUPPLIES

Ungar

- UTC 100 Temperature controlled soldering system \$67
- 4024 De-soldering service station 414.
- 9000 Temperature controlled soldering station 208.
- 6970 HD Heat gun (gives 1000 watts) 72.
- 1095 Heat gun (gives 1000 watts) 35.
- 1100 Soldering gun 100/140 watts 20.

WELLER

- WTCPR Control output soldering station \$119.
 - 8200 All purpose soldering gun 21.
 - D550 28.58
- Kester solder and multicore solder available CALL!*



"I GUARANTEE YOUR SATISFACTION!"
For 43 years professionals have counted on KELVIN, for the lowest prices and immediate delivery, from our huge inventory. Count on KELVIN!
Lisa S. Madar
Executive V.P., C.P.A.

WE CARRY
Panavise, Xcelite Tools, Vaco Tools, X-Acto, Kester Solder, Sellstrom Safety Equipment

- Electronic Parts
 - Electrical Parts
 - Large Selection of State of the Art Educational Kits.
- Not Responsible For Typographical Errors.

KELVIN FREE CATALOG 1-800-645-9212

ELECTRONICS 7 FAIRCHILD AVE., PLAINVIEW, N.Y. 11803 (516)349-7620 FAX: 516-349-7830

observed downstream in the circuit. A decoupling capacitor removes the signal from the circuit; it is not seen at any point downstream in the circuit.

In Figure 1a, examples of the six uses for capacitors are: C_{121} , C_{122} , coupling capacitors; C_{118} , C_{120} , C_{132} , C_{133} and C_{201} , decoupling capacitors; C_{119} , C_{124} , C_{125} , C_{126} and C_{130} , bypass capacitors; C_{117} , a capacitor used in a resonant circuit. Unfortunately, there is no clear-cut case of wave shaping or bias clamping on this partial diagram. Waveshaping would involve either integrating or differentiating a waveform. Bias clamping would involve charging a capacitor and using that charge to influence the operation of a stage.

Circuit evaluation

Figure 7 shows Q_2 and Q_3 with circuit modifiers installed. The function of each capacitor becomes clear when the input signal is known. The input signal is an amplitude-modulated signal at 45.75MHz; it consists of a 41.25MHz audio signal (on peaks of signal), a

video signal varying in amplitude and frequency from 0MHz to 4MHz, and synchronizing pulses at a 15,750Hz rate. This signal is applied through the tuned circuit consisting of L_{106} and C_{117} (tuning capacitor) and applied to diode D_{100} . Diode D_{100} rectifies the negative peaks of the incoming signal. The low-pass filter, which consists of L_{107} , L_{108} and C_{118} through C_{132} (decoupling capacitors), removes the 45.75MHz carrier signal.

Amplitude variations of the applied signal are applied to the base of Q_2 . This stage functions both as a common emitter and a common collector amplifier. The full applied signal appears at the unbypassed emitter of Q_2 . The signal developed across R_{124} is applied to the junction of C_{121} and R_{126} . C_{121} offers little opposition (0.48Ω) to the 4.5MHz audio signal. This signal is routed through C_{121} to the audio frequency amplifier. The remaining signal, consisting of blanking pulses and the video and horizontal sync, is routed to the cathode of the CRT (see Figure 1a).

Resistor R_{126} is a critical component because it has a 5% tolerance rating. If this resistor should decrease in value, a portion of the 4.5MHz audio could be passed to the CRT. If so, it could cause a herringbone pattern (slanted lines appearing as a voice is heard) on the CRT face.

The video and sound signals also appear at the collector of Q_2 . However, the large decoupling capacitor C_{120} presents a low impedance and decouples the sound and a major portion of the video signal to ground, leaving the low-frequency (60Hz) horizontal blanking and sync pulse. These pulses are routed to the AGC and sync separator, which uses only the blanking and sync pulse of the video signal. Decoupling the video and sound information at the collector of the transistor is a protective measure to prevent noise pulses or video signals from reaching the AGC and sync separator. Noise pulses equal in amplitude to the sync pulse could cause false synchronization of the horizontal oscillator and could disrupt proper scan-

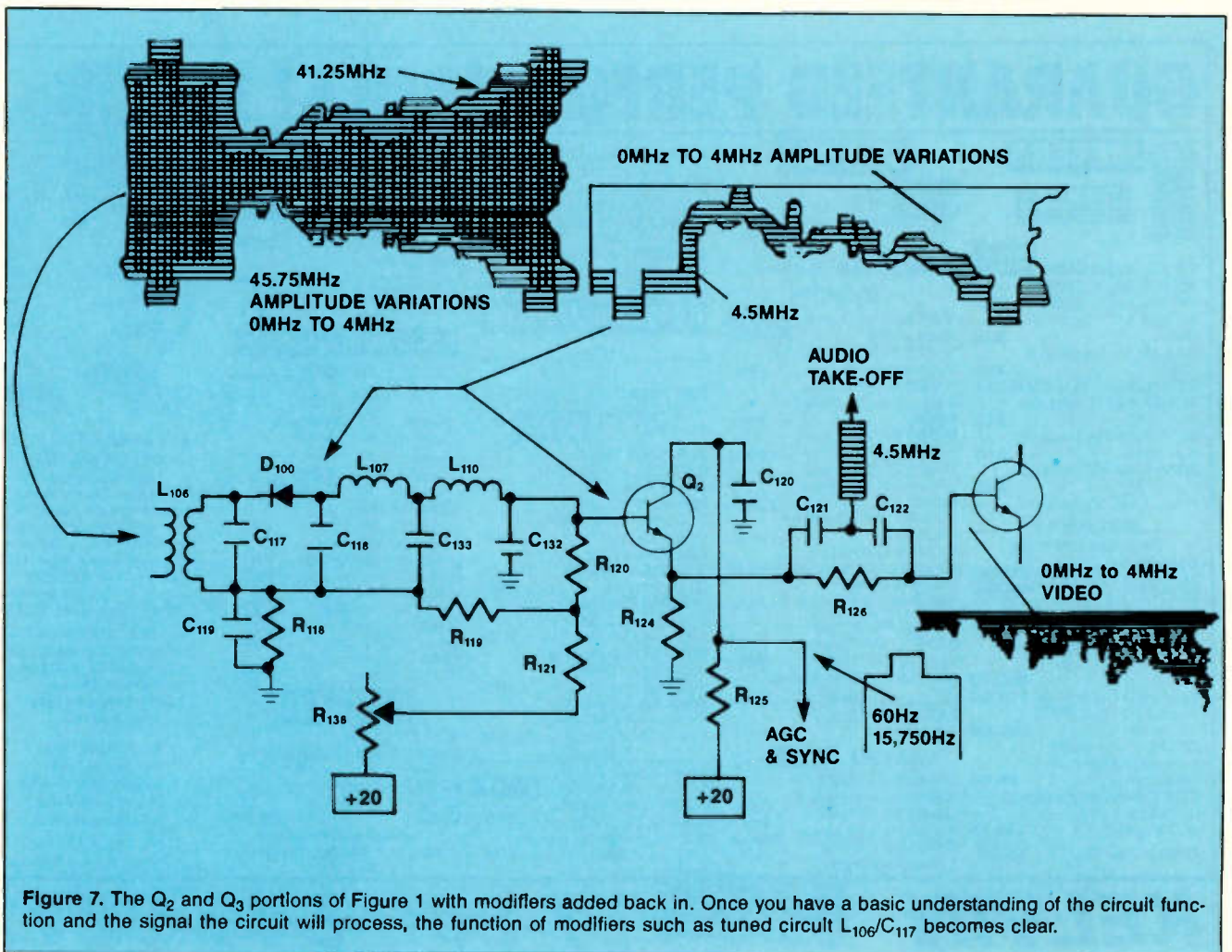

Figure 7. The Q_2 and Q_3 portions of Figure 1 with modifiers added back in. Once you have a basic understanding of the circuit function and the signal the circuit will process, the function of modifiers such as tuned circuit L_{106}/C_{117} becomes clear.

ning. If keyed AGC is employed, it is immune to most noise pulses; however, a peak AGC would be protected against noise occurrence.

There is no doubt that understanding the theory of operation of a device greatly simplifies understanding the function of individual circuit components. It

points out the importance of learning the overall function of a device or system, the block diagram of the device and the input and output signals of each of the blocks. Once you know this information, resolving circuit and component function becomes easier.

Even if you don't know the signal input to the stage shown in Figure 2, sufficient information is still available to form an educated opinion as to the component function. Common sense must also prevail. You must assume that the designer of a stage will not deliberately eliminate any signal that he has use for, and that a decoupling capacitor must be intended to eliminate only undesired byproducts of the stage operation.

Drawing inferences about IC-based circuits

Shown in Figure 8 is a partial diagram of a radio receiver. The section of the circuit selected is an integrated circuit. Integrated circuit component function is more difficult to determine because a large portion of the circuit is contained within the IC. However, you can still

draw certain conclusions from the information provided. Evaluate Figure 8 and compare your conclusions with the following:

- The input capacitor to the IC is electrolytic. This signifies that either the input has a low-frequency component, or the input impedance of the IC is very low.
- L_7 and C_{50} form a 19kHz tuned circuit. Also shown is a tuned circuit at 38kHz. Because this is double 19kHz, you can judge that there is a frequency doubler circuit in the IC.
- Q_{21} operates a stereo indicator lamp. You must assume that this indicator operates from the incoming signal, possibly 19kHz.
- Pins 5, 8 and 9 provide operating voltages to the integrated circuit. This is an important find. Sometimes it is difficult to determine which of the applied

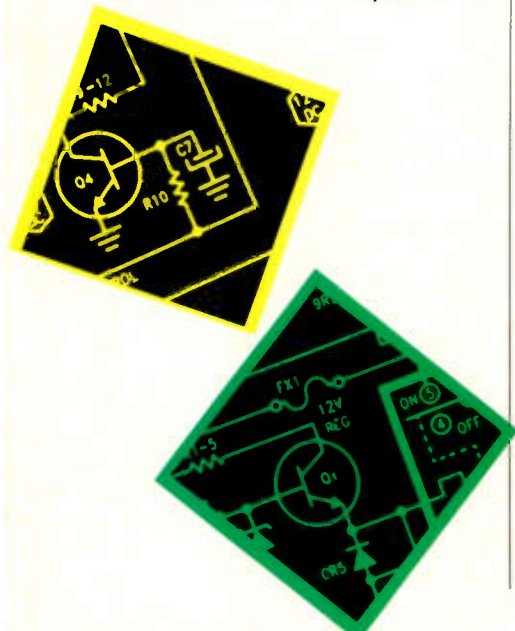

INTRODUCING THE AR-100 MAXI-PROBE™

The World's First Pen-Style DMM with Built-In 10MHz Logic Probe

INNOVATION, NOT IMITATION

The AR-100 Maxi-Probe. Unheard of features and performance in one small package. Volts, Ohms, Audible continuity, Data Hold.

Then add a full-function, TTL/CMOS logic probe. Screw-on accessory tips. Diode Test, Test Leads. And a storage case.

Result: All the functions you need for both analog and digital testing in one small package, at one low price.

So visit your local ARI distributor and take hold of the future, today. The AR-100 Maxi-Probe. All others pale by comparison.

Measure:

- Volts •Ohms •Diodes
- Audible Continuity

And:

TTL & CMOS Logic To 10MHz!

Features:

- Screw-On Accessory Tips
- Data Hold



AMERICAN RELIANCE INC.
VALUE BEYOND MEASURE

(800) 654-9838

ARI manufactures a complete line of electronic test equipment, including EPROM, EEPROM, and PLD programmers, IC testers, Cable testers, DPMs, DMMs, and Logic testing devices. Call or write today for your free catalog.

Circle (11) on Reply Card

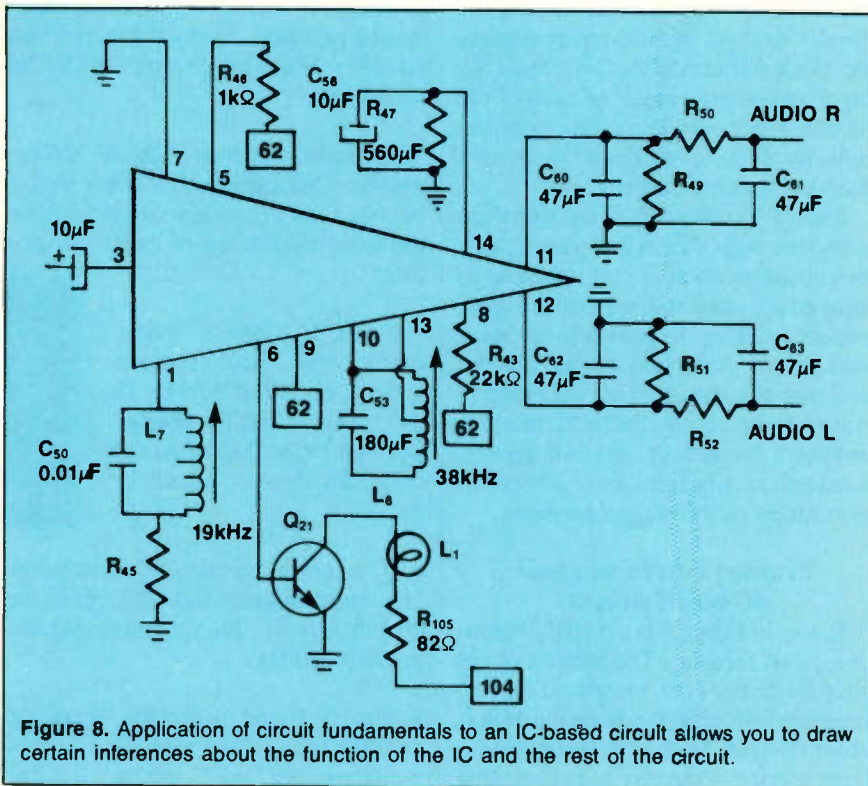

Figure 8. Application of circuit fundamentals to an IC-based circuit allows you to draw certain inferences about the function of the IC and the rest of the circuit.

and C_{53} are part of the resonant circuits. C_{58} is a bypass capacitor. Based on its size, it bypasses a low-frequency component below either 19kHz or 38kHz. It probably functions as the emitter bypass of an amplifier amplifying the low-frequency component of the incoming signal. (See the first point.)

Figure 8 is actually a multiplex modulator of an FM stereo system. The IC input signal contains several frequency components, including audio (up to 15kHz), a stereo pilot frequency of 19kHz and stereo information in the range of 23kHz to 53kHz. The output is stereo, consisting of a left and a right channel. The audio has a 38kHz component that is eliminated by the cited decoupling capacitors C_{60} through C_{63} .

Your evaluation of Figure 8 may have been limited to determining the function of various capacitors, or it may have been more thorough. Your evaluation can only be as complete as your knowledge of components and their function. No doubt evaluation would have been easier had you known the function of the stage and the composition of the input signal. The importance of this type of information to circuit evaluation cannot be overemphasized.

Circuit simplification and evaluation

Figure 9 is another circuit to be evaluated. This circuit was extracted ex-

voltages is responsible for chip operation.

- Pins 11 and 12 provide an output from the chip. Included in this output is a high-frequency component, as evidenced by the decoupling capacitors

C_{60} through C_{63} . Because 19kHz and 38kHz are involved in the IC, it is safe to assume that audio contains one of these signals.

- Capacitors C_{60} , C_{61} , C_{62} and C_{63} are decoupling capacitors. Capacitors C_{50}

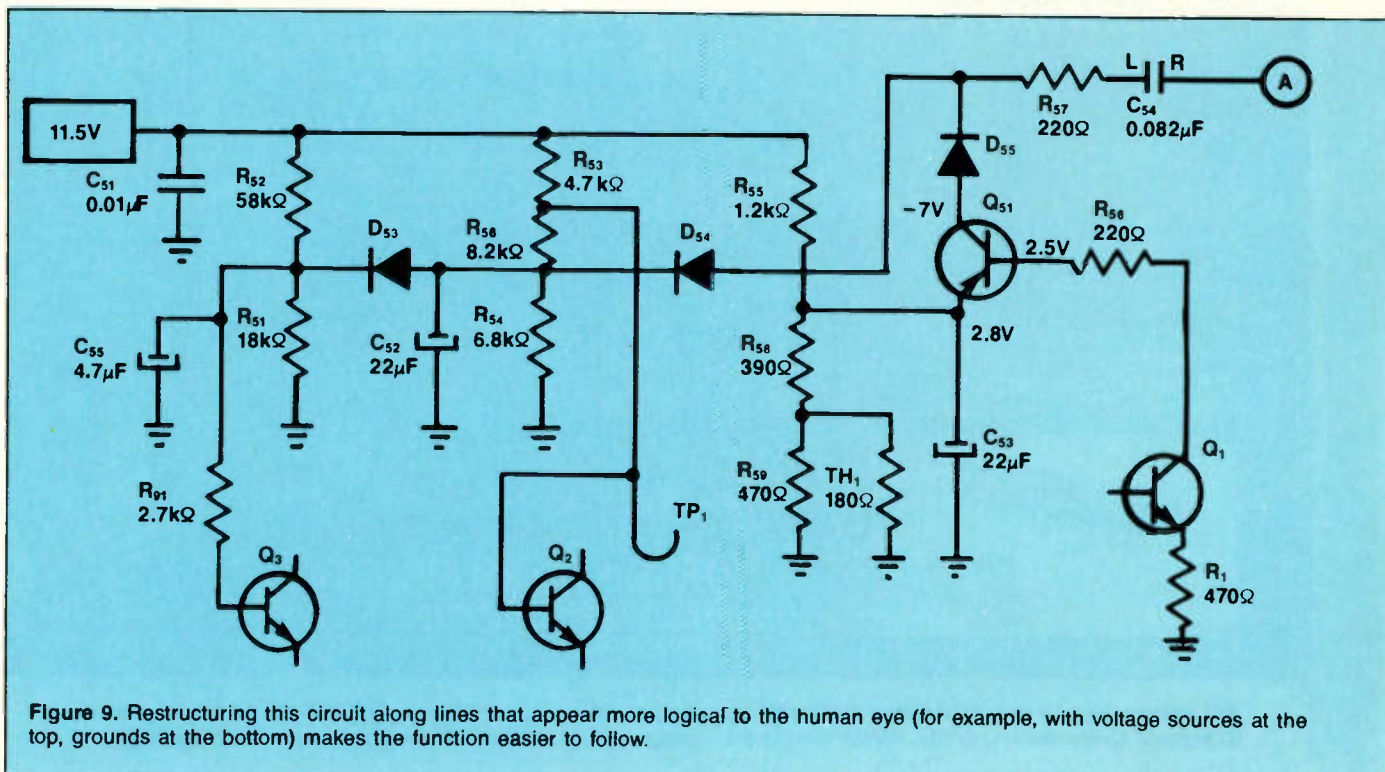

Figure 9. Restructuring this circuit along lines that appear more logical to the human eye (for example, with voltage sources at the top, grounds at the bottom) makes the function easier to follow.

actly as shown on the schematic diagram. Figure 9a shows this circuit after it has been restructured. Reactive components have been left in the circuit because evaluation will include ac signals.

Figure 9a, the simplified version of the circuit shown in Figure 9, may appear complex, but it is much simplified from the former version. The key elements to examine in this circuit are diode D_{55} and the base and collector voltage of transistor Q_{51} . Diode D_{55} is reverse-biased. Conduction of transistor Q_{51} is dependent on the diode and transistor base both receiving a negative pulse simultaneously. The only voltage applied to this circuit is from the +11.5V V_{CC} source. The remaining circuit points, with the exception of C_{54} , are grounded.

Conduction of D_{55} is dependent on the simultaneous application of a negative pulse at point A and the base of transistor Q_{51} . The value of C_{54} indicates that the pulse at that point must have a fast rise time or be of a high frequency. Otherwise, attenuation across the capacitor would reduce the pulse height to an ineffective level. One must also conclude that the pulse will rise to a value much higher than -7V because it must exceed that value for D_{55} to conduct, and the negative potential on the collector of Q_{51} is the average potential at that point. The pulse, or

signal, applied to the base of Q_{51} through Q_1 must occur simultaneously with the application of the negative pulse to capacitor C_{54} , or Q_{51} cannot conduct.

When power is applied and no input signal is present at the base of Q_{51} , current flows from ground through R_{51} and R_{52} to V_{CC} and through R_{54} , R_{56} and R_{53} to V_{CC} . These paths establish the no-signal bias potential on Q_2 and Q_3 . D_{53} and D_{54} are reverse-biased by the higher positive potential at the junctions of R_{51} , R_{52} and R_{54} , R_{56} .

Current flow, with application of the specified pulses, is into the plate labeled R of C_{54} , out of the plate labeled L, through R_{57} , diode D_{55} , the collector to emitter of Q_{51} , and through R_{55} to the 11.5V source. Current flow through R_{59} and thermistor TH_{51} , to V_{CC} and through R_{56} establishes the bias potential at the emitter of Q_{51} . C_{53} , a bypass capacitor, holds the emitter at the established potential when Q_{51} conducts.

During conduction of Q_{51} , the plate labeled L of C_{54} develops a positive charge. When the negative pulse is removed, C_{54} must discharge, from ground, through R_{54} , D_{54} and R_{57} . This increases the positive potential at the junction of R_{54} and R_{56} , which increases the positive charge on C_{52} . The increased charge on C_{52} forward-biases D_{53} and increases the positive bias

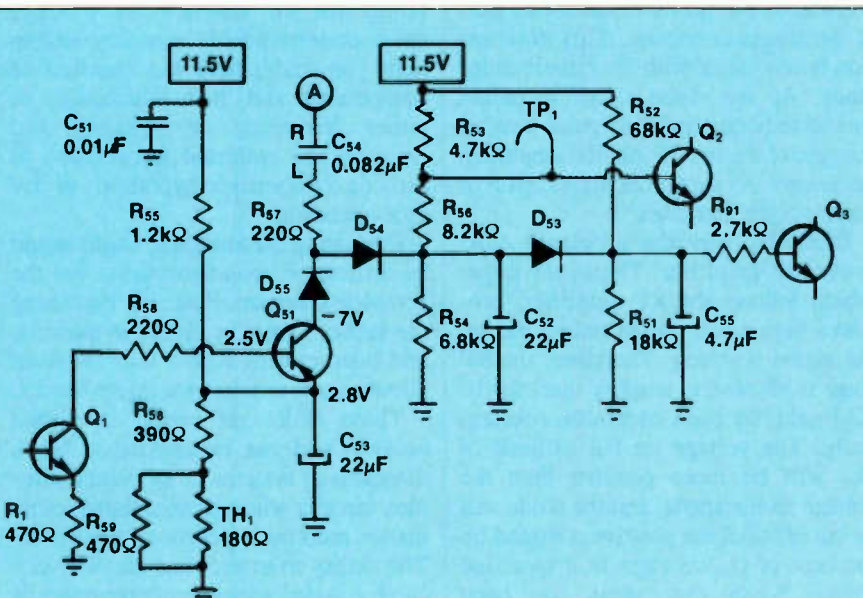

HITACHI SCOPES

15-25% Discount



V1060
100MHz
\$1285

V660 60MHz Dual Trace **\$949**
V422 40MHz Dual Trace **\$699**
V212 20MHz Dual Trace **\$379**

ELENCO PRODUCTS AT DISCOUNT PRICES!



\$498
MO-1252

Scopes

Delayed Sweep 12KV HV, More
MO-1252 35MHz Dual Trace **\$498**
MO-1251 20MHz Dual Trace **\$349**
w/ Two 1x, 10x 100MHz probes, manual
S-3000 10MHz fully calibrated **\$239**
P2 Scope Probe 100MHz **\$23.95**
P1 Scope Probe 65MHz **\$19.95**

GF-8016 Function Generator with Freq. Counter



\$239.95

Sine, Square, Triangle
Pulse, Ramp, .2 to 2MHz
Frequency .1 thru 10MHz

GF-8015 without Freq. Meter \$179

Digital Triple Power Supply

Model XP-765 \$239.95



0-20V @ 1A
0-20V @ 1A
5V @ 5A

Fully Regulated, Short Circuit Protected
with 2 Limit Cont. 3 Separate Supplies
XP-660 w/ Analog Meters \$169.95

Color Convergence Generator



SG-200
\$69.95

Finest in the Industry
10 rock steady patterns

Digital LCR Meter

\$138.95

Model LC-1800

Measures
Inductors,
Capacitors,
Resistors



Multimeter with Cap. and Trans. Tester

\$55.95

Model CM-1500A

8 Functions
with Case



C&S Sales Inc., 1245 Rosewood
Deerfield, IL 60015 (312) 541-0710
800-292-7711 ASK FOR CATALOG

15 Day Money Back Guarantee
2 Year Limited Guarantee
Add 5% for Postage (\$10 max)



IL Res., 7% Tax

Circle (12) on Reply Card

potential on Q_3 . The increased positive potential at the junction of R_{54} and R_{56} raises the positive potential at the junction of R_{56} and R_{53} , increasing the bias on Q_2 . Capacitor C_{52} is a decoupling (filter) capacitor, which decouples the ripple frequency caused by pulses of current through R_{54} and smooths dc bias changes to Q_2 and Q_3 .

The junction of D_{54} and D_{53} is at approximately +4V:

$$\frac{(V_{CC})(R_{54})}{(R_{54} + R_{56} + R_{53})} = \frac{(+11.5)(6.8)}{20} = 3.9V$$

(The voltage drop is equal to the ratio of R_{54} to the total resistance of the circuit.) This does not take into consideration the current flow through D_{53} or the emitter/base junction of Q_2 . The positive potential of C_{54} must, therefore, exceed +4V for D_{54} to conduct. The voltage at the cathode of D_{53} is approximately 2.4V, based on the ratio of R_{51} to R_{51} and R_{52} . Again, this does not take into consideration the current flow through Q_3 . Considering the voltage drop across D_{53} , the potential applied to the base of Q_3 would be approximately 3V. The bias on Q_2 would be something greater than 4V.

If either the pulse at A or the pulse on the base of Q_{51} were to increase, the positive potential at C_{54} would increase. The base of Q_2 and Q_3 would then increase as well. It appears, then, that the bias on Q_2 and Q_3 is dependent on the conduction of Q_{51} , and the pulse height of the applied signal from Q_1 .

In this circuit, C_{51} is a high-frequency decoupling capacitor. TH_{51} is a negative temperature thermistor that maintains a bias on Q_{51} , which is inversely proportional to the ambient (surrounding) temperature (protection against I_{CBO} current).

Knowledge of the function of the circuit and the input signals would be a great help in analysis of circuit operation. The circuit just evaluated is the automatic gain control circuit of a television receiver. Its function is to maintain a constant gain at the output of the receiver IF section despite any changes in level of input signal. Q_1 is the input to the AGC circuit and the video signal appears at this point. The signal at point A is developed by the horizontal section and is of constant amplitude. It is used as a reference to determine if the incoming signal changes level. If the gain of the input signal increases, the positive potential at the junction of R_{54} and R_{56}

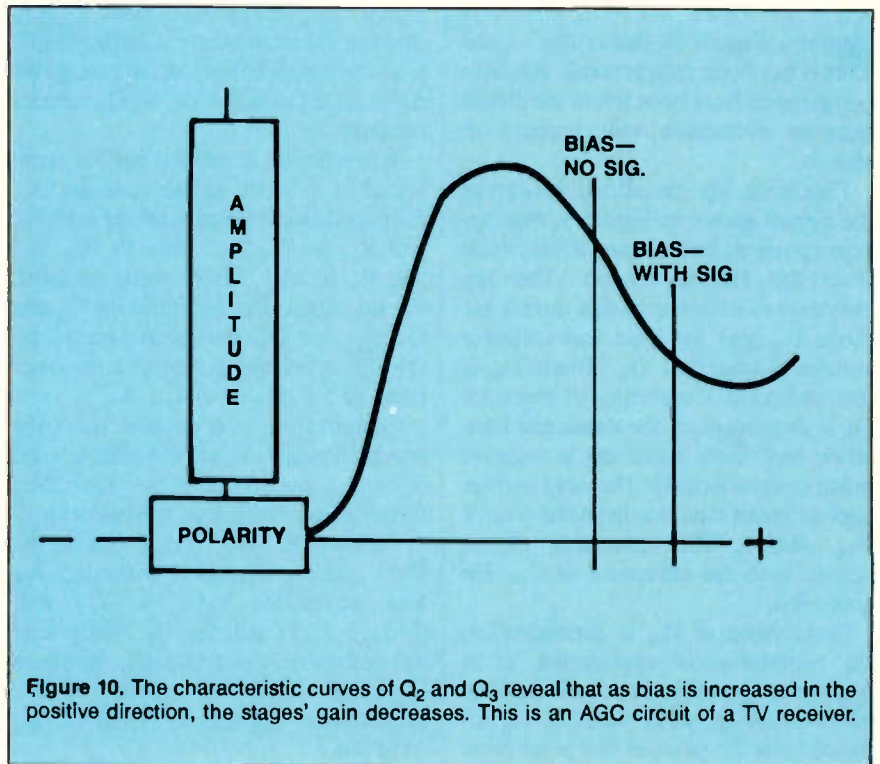

Figure 10. The characteristic curves of Q_2 and Q_3 reveal that as bias is increased in the positive direction, the stages' gain decreases. This is an AGC circuit of a TV receiver.

and R_{56} and R_{53} increases and reduces the gain of Q_3 and Q_2 , the RF and first IF amplifier, respectively.

In this device, Q_2 and Q_3 are biased on the reverse slope of the conduction curve and decrease gain with an increase in forward bias (see Figure 10). As indicated by Figure 10, as bias is increased in the positive direction, gain of the stages decreases. This observation is consistent with the circuit under study. As the video signal increases (negative horizontal sync pulse peaks), the gain of the first IF and RF amplifiers decreases. As signal decreases, gain of these stages increases.

Diode D_{53} provides a delayed AGC to the RF amplifier. The mixer stage, which follows the RF amplifier, produces high noise output unless the input signal is strong. Therefore, the RF stage is allowed to amplify until the IF (Q_2) gain has been decreased substantially. The voltage on the cathode of D_{53} will be more positive than the voltage on the anode, and the diode will be cut off until the positive potential on the base of Q_2 has risen to a specified value. When that value has been reached, the voltage drop across R_{54} will produce a sufficient positive voltage at the anode of D_{53} to turn it on and cause the positive potential on the base of the RF amplifier to rise, decreasing gain at that stage.

The foregoing examples and discussion were intended to demonstrate how simplifying circuits can help you determine circuit structure, methods of biasing, function of components and basic concepts of circuit operation. To simplify circuits, you must be able to extract circuits from a larger diagram, reorganize the diagram (to produce more understandable circuitry and to help you understand the function of components and their relationship to either frequency or voltage), and organize the collected information to provide a reasonable hypothesis of circuit operation.

Evaluating the foregoing stages would be difficult if you attempted to use the complete schematic diagram. Extracting the section, stage or circuit in question and restructuring it to a familiar form allows you to concentrate on the circuit.

These skills are useful in circuit analysis and can be applied to block diagrams of systems or any other complex circuits where accumulated information must be organized or structured. The ability to extract and simplify circuits, coupled with an understanding of the basic operation of components, is a valuable tool in the technician's box. It, like any tool, will rust with disuse. It should be used periodically, even when not necessary, to polish and restore its luster.

1
Chassis—RCA CTC71
PHOTOFACT—1380-2 (1435-3)

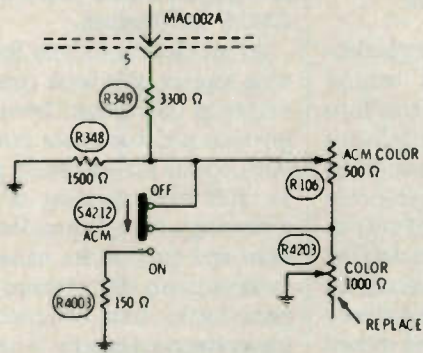

Symptom—Varying color intensity
Cure—Test R4203 color control by substitution

4
Chassis—RCA CTC76
PHOTOFACT—1468-2 (1519-2)

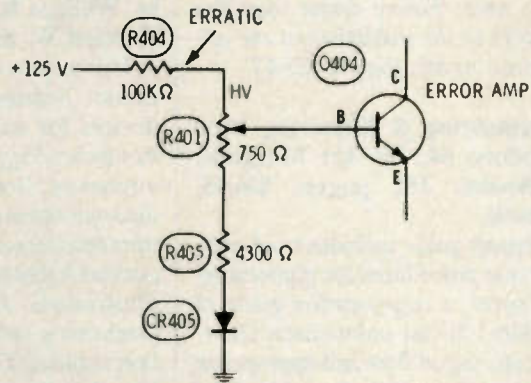

Symptom—Intermittent width change; or loss of regulation
Cure—Check R404, and replace it if increased or erratic

2
Chassis—RCA CTC72
PHOTOFACT—1439-2 (1518-2)

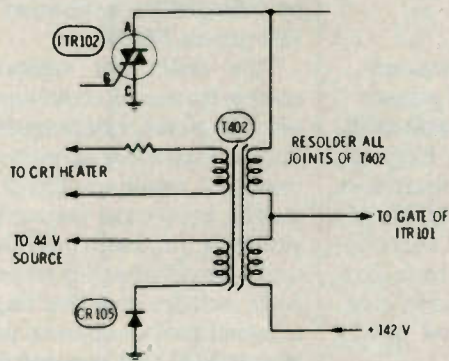

Symptom—Intermittent or no raster; intermittent or no CRT heater voltage
Cure—Check and resolder all joints of T402

5
Chassis—RCA CTC39X
PHOTOFACT—1126-3 (1284-2)

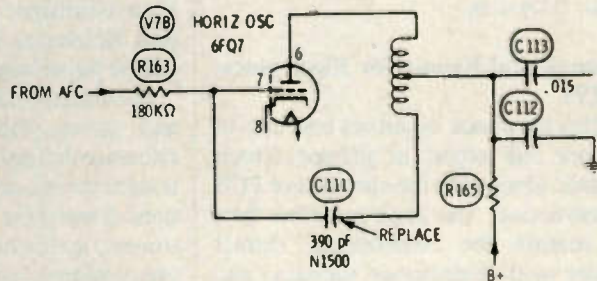

Symptom—Frequent failure of 6ME6 horiz output tube
Cure—Check and resolder joints of C111 at grid of horiz osc

3
Chassis—RCA CTC71
PHOTOFACT—1380-2 (1435-3)

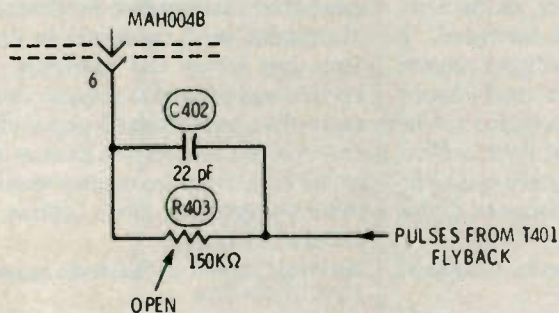

Symptom—Picture too far to the left; blanking bar at right
Cure—Check R403, and replace it if open

6
Chassis—RCA CTC58
PHOTOFACT—1365-1 (1428-2)

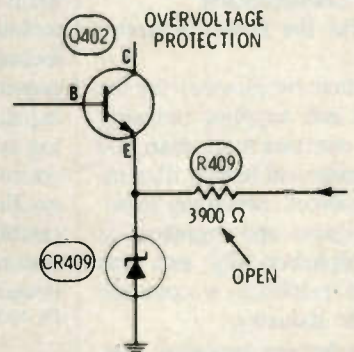

Symptom—Edges of picture not straight
Cure—Check R409, and replace it if open or increased

Editor's note: Please direct inquiries and orders to the publisher at the address given rather than to ES&T.

Troubleshooting & Repairing Your Commodore 64, by Art Margolis; TAB Books; 351 pages; \$16.95, paperback.

This repair guide includes tried-and-true service procedures for pinpointing trouble spots; a chip-location guide of all 32 chips; 21 test-point charts showing pinouts, signal flow and appropriate readings; and a master schematic of the computer with all parts numbers. An in-depth examination of the C-64 circuits includes timing diagrams, the use of PEEK and POKE commands to signal-trace circuits, and more. For the novice, the book also includes maintenance tips, easy troubleshooting procedures and do-it-yourself repair techniques.

TAB Books, P.O. Box 40, Blue Ridge Summit, PA 17214; 717-794-2191.

Rework and Repair for Electronics; \$15.75.

This handbook describes concepts of rework and repair of printed circuit boards, along with the elements of PCB construction. The book describes how to remove the components, extract solder with continuous vacuum, and remove conformal coatings. Lessons cover how to repair PCBs and plated-through holes, how to refurbish or replating repaired or worn edge connectors, and how to prevent electrical damage to sensitive components.

Pace, 9893 Brewers Court, Laurel, MD 20707; 301-490-9860.

Handbook of Standardized Terminology for the Power Sources Industry; \$25.

As a comprehensive glossary for the power sources and supplies industry, this handbook contains more than 900 definitions of technical terms, illustrations and appendices, providing information for designers and engineers. It is formatted alphabetically and was edited to help establish a common language for the industry.

Power Sources Manufacturers Association, Dept. RLS, 8833 Sunset Blvd., Suite 404, Los Angeles, CA 90069.

Understanding Automotive Electronics, third edition,

by William B. Ribbens; Howard W. Sams; \$17.95.

This step-by-step guide through electronic instrumentation and control devices for automobiles explains how this technology functions in today's environment. Besides detailing electronic instrumentation, this book explains the microprocessor and its pivotal role in auto performance, and includes detailed illustrations for such functions as diagnostics, sensors and engine and motion control. The book is aimed toward the beginning/intermediate level automotive mechanic, industrial training student or "backyard" auto repair hobbyist.

Howard W. Sams, 4300 W. 62nd St., Indianapolis, IN 46268; 800-428-SAMS.

The Illustrated Dictionary of Electronics, 4th Edition, by Rufus P. Turner and Stan Gibilisco; TAB Professional and Reference Books; 656 pages; \$23.60 paperback, \$36.95 hardbound.

Illustrated with drawings, diagrams and tables, this revised electronics reference defines more than 27,000 electronics terms, acronyms and abbreviations drawn from the areas of basic electronics, mathematics, electricity, communications, computers and newly emerging technologies.

TAB Professional and Reference Books, P.O. Box 40, Blue Ridge Summit, PA 17214; 717-794-2191.

Advanced Digital Troubleshooting, by Alvis J. Evans; Howard W. Sams, \$19.95.

This illustrated tutorial provides comprehensive coverage of digital test equipment for intermediate-level electronics technicians, maintenance technicians, technical students and hobbyists. It presents a brief review of digital circuits; explains several successful troubleshooting techniques; discusses digital test instruments such as digital logic probes, oscilloscopes, logic analyzers and an in-circuit emulator; and discusses digital system maintenance.

Howard W. Sams, 4300 W. 62nd St., Indianapolis, IN 46268; 800-428-SAMS.

Learning Electronics: Theory and Experiments, With Computer-aided Instruction for the Commodore 64/128, by R. Jesse Phagan and William Spaulding; Tab Books;

360 pages; \$16.60 paperback, \$24.95 hardbound.

As an electronics text for the beginning student, this book combines three modes of instruction: theory, hands-on practice and computer exercises. The book covers the necessary groundwork for full understanding of electronics technology. Sample problems, lab exercises and quizzes are included to help readers grasp introductory theory and basic math. Also, computer programs that correspond exactly to the theory and lab material are provided for nearly every chapter. For those who prefer, this book is also available for use with the IBM PC and the Apple.

TAB Books, P.O. Box 40, Blue Ridge Summit, PA 17214; 717-794-2191.

Printer Troubleshooting & Repair, by John Heilborn; Howard W. Sams, 250 pages; \$19.95.

This book was written for the intermediate-to-advanced computer user who has a basic understanding of electronics. It provides answers to the most common repair problems for dot-matrix, ink-jet and laser printers, emphasizing preventive maintenance as well as troubleshooting techniques. The book includes exploded diagrams and schematics of component parts. A list of sources is also provided for replacement parts.

Howard W. Sams, 4300 W. 62nd St., Indianapolis, IN 46268; 800-428-SAMS

Electronic Databook, 4th Edition, by Rudolf F. Graf; Tab Books; 560 pages; \$24.60 paperback, \$34.95 hardbound.

Included in this edition is illustrated and indexed information for about every electronics need, arranged in theory-free data tables and examples. This revised and expanded volume includes more than one hundred pages of new and updated information such as space technology, robotics, modem standards, microcomputers, fiber optics and cellular telephony.

Tab Books, P.O. Box 40, Blue Ridge Summit, PA 17214; 717-794-2191.

20 Innovative Electronics Projects for Your Home, by Joseph O'Connell; Tab Books; 256 pages; \$13.60 paperback, \$21.95 hardbound.

Projects in this book begin with basic

background and information about the parts involved in each design. Readers then follow the drawings and photographs to construct the devices. Although many designs are easy enough for beginners, included at the end of each chapter is a section on modifying and embellishing each project. Among the projects explained are a regulated voltage and current supply, a ringing-telephone alerter, a telephone hold button and an electronic distance measuring system.

Tab Books, P.O. Box 40, Blue Ridge Summit, PA 17214; 717-794-2191.

How to Design Solid-State Circuits, 2nd Edition, by Mannie Horowitz and Delton T. Horn; Tab Books; 380 pages; \$16.60 paperback, \$24.95 hardbound.

This book provides both the theoretical background and practical design tips for a variety of semiconductors and tells how and why these circuits are designed. Appropriate for intermediate electronics hobbyists or students, this book is also useful as a reference and refresher for professional engineers or circuit designers. Circuit diagrams are provided along with relevant equations. Also, a section on applying Boolean algebra to digital design is included.

Tab Books, P.O. Box 40, Blue Ridge Summit, PA 17214; 717-794-2191.

PHOTOFACT

HITACHI

2591-1 CT2260/60H/62
2592-1 CT2561, CT2562

JVC

2591-2 C-1327
2592-2 C-2017, C-2027

MAGNAVOX

2586-1 CHASSIS 26C901/02/
03/04, 27C901/02/03/04/
05/06/07/09/10/11/12/13

MITSUBISHI

2587-2 CSI456R

QUASAR

2588-1 TL9982AW
(CH. AEDC126)
2589-1 TP3957BE/57BW/
67BE/67BH/67BT/
67BW, YTP3957BE

SEARS

2588-2 564.42107750/51/52,
564.42109750/51/52

SONY

2586-2 KV-1392R, KV-1393R
(CH. SCC-A81C-A/B-A)
2587-1 KV-20HFR
(CH. SCC-A05D-A/K-A)

TEKNIKA

2589-2 7496, 7498B
(CH. ECC-2622)

TOSHIBA

2590-1 CF2647, CX2827C,
CX2847C

ZENITH

2590-2 SC1935S, SC1935W

ES&T

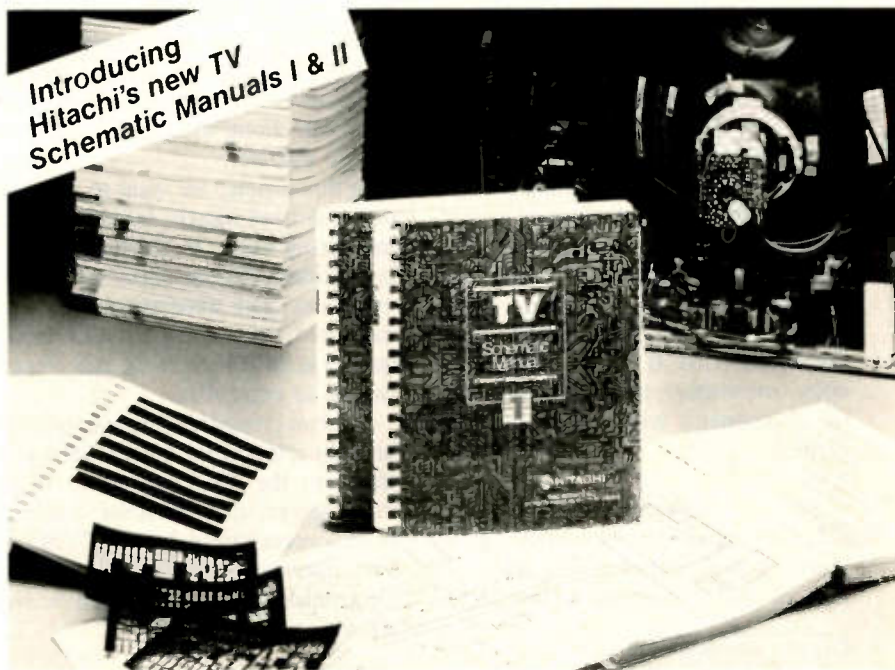

All the technical data of 83 Hitachi TV Manuals—in just two volumes



Our new Hitachi TV Schematic Manuals give you the best of both worlds—

With the compact storage of 32X microfiche and full-view hard copies of the items you use the most. Organized by year and model number in both formats, these volumes give you everything you need—83 models from 1975–1981. They're neatly packaged, easy to use, and economically priced.

You'll get hard copies of:

- Schematic Diagrams • Block Diagrams
- Printed-Circuits Board Layouts • Part Lists • Mechanical Part Exploded Views

And get the works on microfiche:

- Service Manuals with Technical Data and Information • Troubleshooting Tips • Revised or Supplemental Manuals • Instruction

Manuals • Parts and Service Bulletins

Volume I covers: 54 models from 1975–1978.

Volume II covers: 29 models from 1979–1981.

That's a lot of service data for a low **\$54.95** per volume! About what you would expect to pay for information on only two models. Or save even more by getting both volumes for just **\$104.00**. Take advantage of these savings now. It's a simple, cost-effective way to increase proficiency and increase profit. Also available are our VCR Volumes I, II and III.

Call toll-free 1-800-447-2882 for your nearest Authorized Hitachi Distributor

HSC Service Company

division of Hitachi Sales Corporation of America

Circle (14) on Reply Card

What on earth are kelvins?

By James E. Kluge

Signals received by a home satellite antenna system (also called *TVRO* for TV receive only) are extremely small. Any noise introduced by the amplifiers, which are used to increase the signal amplitude to a level that is usable by a television receiver, will have an adverse effect on the signal. The result is degradation of the picture. Because this factor is critical in determining whether a given system will produce an acceptable picture, manufacturers give a rating to their critical components: low-noise amplifiers (LNAs), low-noise block downconverters (LNBs) and low-noise converters (LNCs). This rating, called *noise temperature*, tells how much noise the components will contribute to the picture.

Noise sources

For all practical purposes, the signals leaving a satellite transponder are noise-free. When they arrive at the TVRO

Kluge is a technical editor at the Winegard Company.

antenna here on Earth, they are still noise-free. The problem is that after the long trek through space, the signals are much, much smaller (attenuated in power level). The signals' size is more on a par with the noise levels with which they now have to compete as they make their way along the signal path to the TVRO receiver.

In this article, we want to focus not on the desired signals, but rather on the interfering noise. In TVRO systems, it is important that we know where noise originates and understand how it is measured, what effect it has on picture quality at the TV receiver, and what we can do to control it.

The two principal sources of noise are broadly categorized as external and internal to the TVRO system. As you might guess, external noise originates from sources external to the TVRO system; internal noise is generated in the electronics used to amplify the received signals.

External noise

External noise finds its way into the system at the antenna the same way the signals do. External noise signals are not

very different from the desired signals. They both consist of radiated electromagnetic energy. In our case, the desired signals are emitted from a discrete source, are programmed and are restricted to a specific band of frequencies. The noise, on the other hand, is random and incoherent, arrives from multiple sources and contains an almost infinite variety of frequencies.

The external noise sources include the stars, our sun, the planets, the moon, plus any terrestrial objects. The warmer the object, the more intense is its radiated energy.

Temperature, as you might infer, plays an important part in the intensity of noise signals. In fact, noise and temperature are directly related.

In order to minimize the effects of external noise, all we need to do is construct an electromagnetic "lens" that focuses only on the desired signal source (the satellite) and discriminates against all other sources, whether they are other programmed signals or random noise.

The reflector antenna

For a TVRO system, the most effective device for accomplishing this trick, in terms of both cost and performance, is a parabolic-shaped, dish-type reflector antenna. (See Figure 1.)

The name of the game, as always, is to maintain an adequate signal-to-noise (S/N) ratio. "Adequate," of course, is a matter of judgment based on how sharp, clear and noise-free the TV pictures need to be.

The object of the system is to maximize the capture of the desired TVRO signals and to minimize the capture of noise. A well-designed antenna will maximize the signal and minimize the external noise, leaving only one problem: What about the internal noise?

Internal noise

Active devices such as diodes and transistors that amplify or control electronic signals generate noise internally.

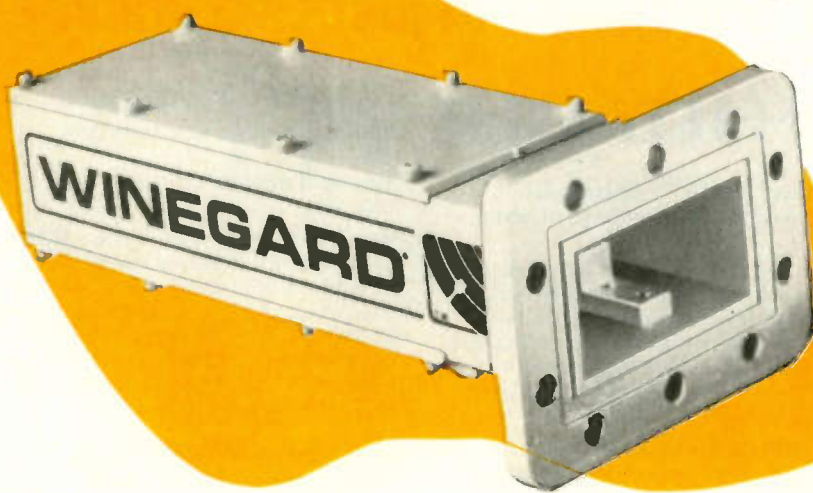

Figure 1. The LNA is a pre-amplifier that must be located directly at the antenna; otherwise, the received signal, which is extremely small, would be so attenuated and swamped by noise by the time it reached the TV set that it would be unusable. It is called a low-noise amplifier because it must contribute very little noise to the small-amplitude received signal that it amplifies, or it would contribute enough noise to make the signal unwatchable.

In a TVRO system, the main contributor of this internal noise is the low-noise amplifier (LNA) because it processes the received signal while it is still at extremely low amplitude. (See Figure 1.) The LNA is, in essence, a pre-amplifier that is located at the antenna. If it is not located directly at the antenna, the received signal, which is extremely small, would be unusable by the time it reached the television set because it would be so attenuated and swamped by noise. It is called a *low-noise amplifier* because it must contribute very little noise to the small-amplitude received signal that it amplifies, or it would contribute enough noise to make the signal unwatchable.

Like any antenna pre-amp, the LNA either makes or breaks the overall picture quality, depending on how much noise it generates internally. It also has a very tough assignment. First of all, it can't do anything about the external noise that enters the system at the antenna. It simply amplifies that external noise along with the signals. What we *don't* want it to do is add any additional noise of its own. How much noise the LNA will add and how that noise contribution is specified in units of temperature is the main focus of this article.

By examining the antenna's performance specs, you can calculate the signal level available at the LNA input. Knowing that, you can select an LNA with a noise contribution low enough to provide an adequate S/N ratio to guarantee clear, sharp pictures at the TV set.

Apart from the antenna, the only other major source of noise is in the LNA. Active semiconductor devices in the amplifier generate *shot* noise in the junctions. Shot noise is predictable and unavoidable. It increases with frequency and can be minimized by using more expensive transistors such as gallium-arsenide, field-effect transistors (GaAsFETs).

In addition to shot noise, every conducting path that has a finite resistance

will generate noise voltages proportional to the resistance and temperature. This thermal noise voltage results from random electron motion, which increases with increasing temperature. At absolute zero, all electron motion ceases and the noise voltage goes to zero—an ideal but impractical situation. In fact, some exotic amplifiers are cryogenically cooled to reduce the thermal noise level.

If an amplifier could be perfectly noiseless, its output power would equal the input power multiplied by the gain. Unfortunately, the actual output power is always a little more than that because of the internal noise contribution between the input and the output termination.

In the real world, noiseless amplifiers don't exist. For C-band TVRO, the lowest practicably achievable noise level is about 85 kelvins. (See Figure 2.) So what does this mean? What in the world are kelvins? How are they related to noise and temperature? To answer these questions, we will have to cover some basics.

Temperature basics

Throughout the world, four basic systems are used to express temperature. The one most commonly used in the United States is the Fahrenheit scale. We

know that when the air temperature falls below 32°F, puddles freeze over, and when it reaches 90°F, you shouldn't walk barefoot on the asphalt.

In most non-English-speaking parts of the world, temperature is expressed in degrees Celsius (°C). In this system, water freezes at 0°C and you don't go barefoot on the asphalt at 32°C. Celsius has replaced the centigrade scale.

A third system, and the one we are concerned with here, is the Kelvin scale of thermodynamic temperature. The unit is the *kelvin* (not degrees Kelvin) and its symbol is *K*. The same name and symbol are used to express a temperature interval virtually equal to 1°C.

So, when you spec an LNA for noise at 100K (100 kelvins), you are talking about 100 units of thermodynamic temperature above absolute zero (zero Kelvin). This 100K is not, obviously, the actual temperature of the amplifier, but rather an *effective* temperature that defines the magnitude of the noise voltage at the amplifier input terminals. Before you can discuss effective noise temperature, however, you have to understand thermal noise.

Thermal noise

In any material, random electron motion caused by the ambient ther-

Low-noise amplifier typical documentation		
frequency (GHz)	gain (dB)	noise temp (K)
3.70	51.8	88
3.95	52.3	78
4.20	51.5	90

Figure 2. Typical documentation enclosed with C-band LNA product specifies effective input noise temperature in kelvins at three discrete frequencies.

modynamic temperature generates a noise power. At absolute zero, there would be no thermal electron motion and, therefore, no thermal noise power generated. As temperature increases, so does the thermal agitation of the electrons. Thus, thermal noise power per unit bandwidth increases in direct proportion to thermodynamic temperature. The mathematical expression for noise power in watts is:

$$P_N = kTB$$

where:

- k = Boltzmann's constant = 1.38×10^{-23} (J/K).
- T = thermodynamic temperature (K).
- B = bandwidth (Hz).

In the case of a resistor, R, at a temperature, T, the open-circuit rms (root-mean-square) noise voltage (E_{rms}) appearing across its terminals can be expressed this way:

$$E_{rms}^2 = 4RkTB$$

In terms of power (watts):

$$(E_{rms}^2/4R) = kTB$$

The term T in the above relationships also can be used to express a noise power that is equivalent to the noise power in a resistor at some effective thermodynamic temperature (T) and bandwidth (B). In other words, if you measure a certain amount of noise power in an LNA, you can substitute that value into the above equation and calculate T, which allows you to use the parameter T to rate the noisiness of LNAs.

Effective noise temperature

To allow prospective purchasers of satellite systems to ascertain the amount of noise that an LNA will introduce into a TVRO system, LNAs are rated in terms of noise temperature or effective noise temperature.

The effective input noise temperature, T_E , is a measure of the noisiness of an amplifier and represents how much noise power the amplifier adds to its input signal when observed at the output termination. (See Figure 3.) T_E is a *fictitious* temperature that is expressed in kelvins and is related to the input termination of an amplifier.

The concept of T_E makes it possible to express the noise generated by an

LNA as though it were noise applied to the input terminations of an ideal, noise-free LNA. Thus, when applied to the input-impedance of a noise-free amplifier, T_E yields the same output noise power as the actual noisy amplifier does when connected to noise-free, input-impedance terminations (that is, when there is no noise at the input port). (See Figure 4.)

So, if an LNA has a noise temperature of 100K, when its input is properly terminated and maintained at a fictitious temperature of 0K, it will deliver an output noise power equivalent to what a noise-free amplifier would deliver if its input termination were at a temperature of 100K. Again, T_E is a fictitious temperature, a noiseless amplifier is fictitious and a noise-free input termination is fictitious. However, these last two representations, fictitious as they are, help us understand the concept of T_E —how it expresses the amount of noise an actual amplifier adds to its input signal, and how that amplifier is rated in terms of temperature to express its noisiness.

Average T_E

Effective input noise temperature as

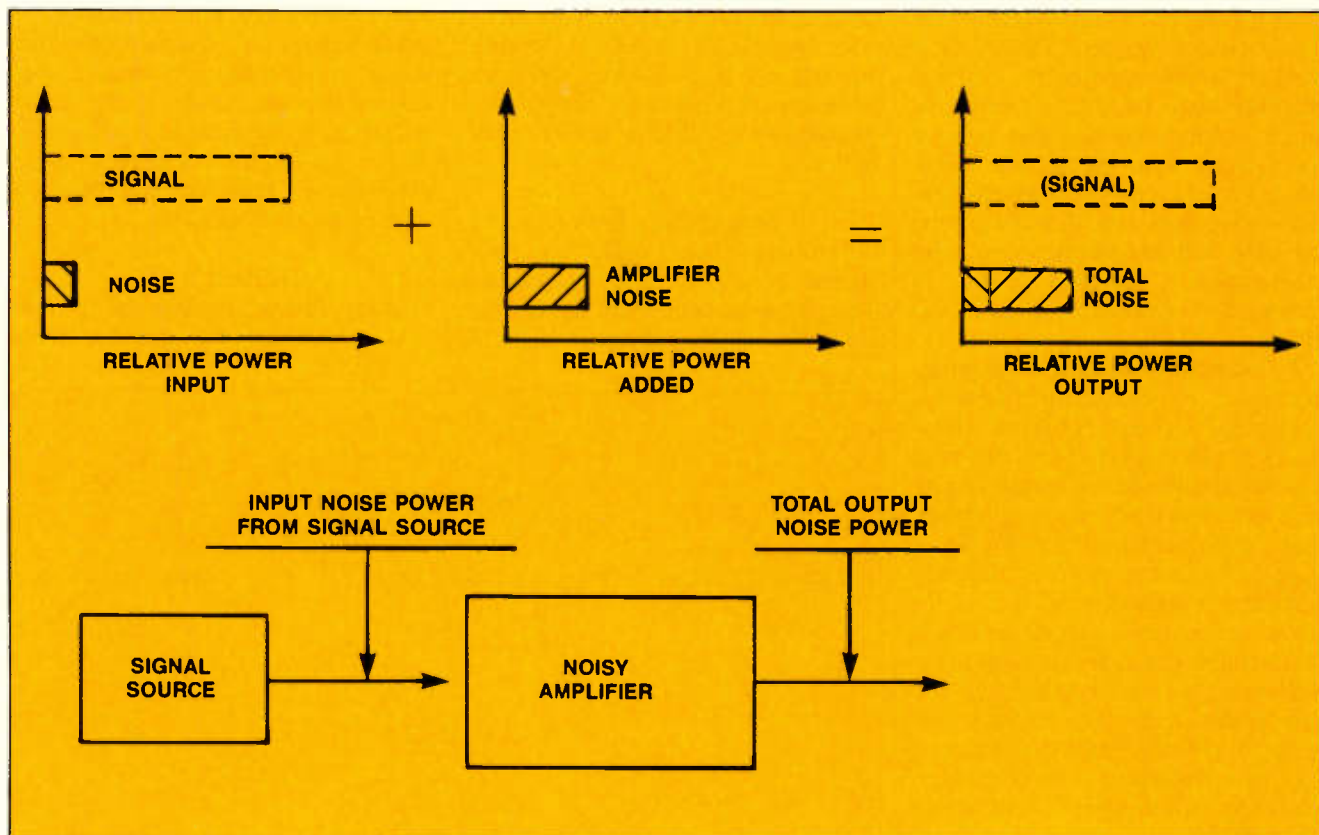

Figure 3. Effective input noise temperature, T_E , is a measure of the noisiness of an amplifier and represents how much noise power the amplifier adds to its input signal when observed at the output termination.

ARM YOURSELF AGAINST STATIC



WITH NTE'S PATENTED FIELD SERVICE KIT.

LOOK FOR THE FULL LINE OF QUALITY NTE
REPLACEMENT PARTS AND PRODUCTS:

Static electricity is a real hazard to sensitive electronic equipment. Now you can protect valuable components in the field and in the plant with NTE's new Field Service Kit.

Our Kit includes everything you need to keep your equipment free of static — a 24" x 24" table top work mat, wrist strap with 8' coil cord, 15' clip-on grounding line and anti-static component storage bags. Both the wrist strap cord and grounding cord contain integral current limiting resistors.

Unlike other kits currently on the market, NTE's patented* three-

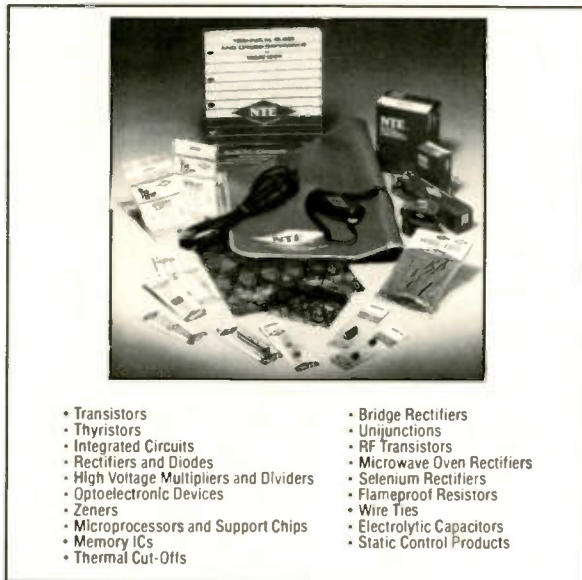

- Transistors
- Thyristors
- Integrated Circuits
- Rectifiers and Diodes
- High Voltage Multipliers and Dividers
- Optoelectronic Devices
- Zeners
- Microprocessors and Support Chips
- Memory ICs
- Thermal Cut-Offs
- Bridge Rectifiers
- Unijunctions
- RF Transistors
- Microwave Oven Rectifiers
- Selenium Rectifiers
- Flameproof Resistors
- Wire Ties
- Electrolytic Capacitors
- Static Control Products

layer construction produces controlled static drain, eliminating the danger of sparking and the chance of additional component failure during the repair operation. The static-dissipative, vinyl work surface is durable and its bright green color enhances visibility. The entire Kit folds down into a compact unit and comes with its own zip-close bag.

Look for NTE's new Field Service Kit and our other static control products — including our anti-static foam, for shipping and storing equipment, and separately packaged wrist straps — at your local NTE distributor.

*Patent issued November 8, 1983.
U.S. Patent No. 4,414,260.



NTE ELECTRONICS, INC.

44 FARRAND STREET • BLOOMFIELD, NEW JERSEY 07003
(Outside N.J.) 1-800-631-1250 • (N.J. only) 1-800-624-2624

For more information or the name of your local distributor, call or write NTE.

Circle (15) on Reply Card

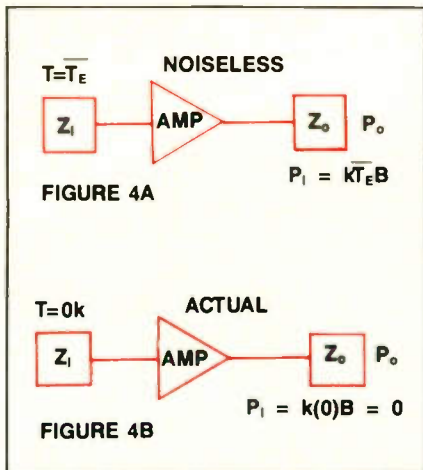

Figure 4. The concept of effective input noise temperature, T_E , uses an imaginary input noise source to a fictitious noiseless amplifier (Figure 4a) to produce the same output power, P_O , that the actual "noisy" amplifier (Figure 4b) produces while having zero noise input ($T=0K$).

defined by the Institute of Electrical and Electronic Engineers (IEEE) is idealized. It describes the noise performance of a linear, 2-port device (one that has an input and output) at a *single* operating frequency.

In a strict technical sense, effective input noise temperature (T_E) is a function of frequency. It is strictly defined in terms of the noise power in a 1Hz bandwidth at a specified frequency, f . However, in most practical applications, noise is measured over a band of frequencies. In TVRO systems, that band can be as wide as 500MHz (in the case of a TV satellite), or as narrow as 36MHz (in the case of a single transponder).

To describe the noise performance over a band of frequencies, an *average* effective input noise temperature, \bar{T}_E , is defined. Thus, in most applications,

we will be technically correct in referring to an average, \bar{T}_E .

As the band of frequencies increases, so will the noise because the term B in the equation $P_N = kT_B$ indicates bandwidth over which the noise is measured. Noise power increases in direct proportion to the bandwidth. The expression kT is expressed in units of energy (joules or its equivalent, watt-seconds), which, when multiplied by the bandwidth in hertz, yields power in watts. Again, each unit increase in noise power is associated with a corresponding unit increase in thermodynamic temperature. Thus, \bar{T}_E serves as a handy expression of noise power or noisiness and is totally unrelated to any actual temperature.

Noise factor or noise figure

The term *noise factor* is a power ratio, F , widely used to designate the noisiness

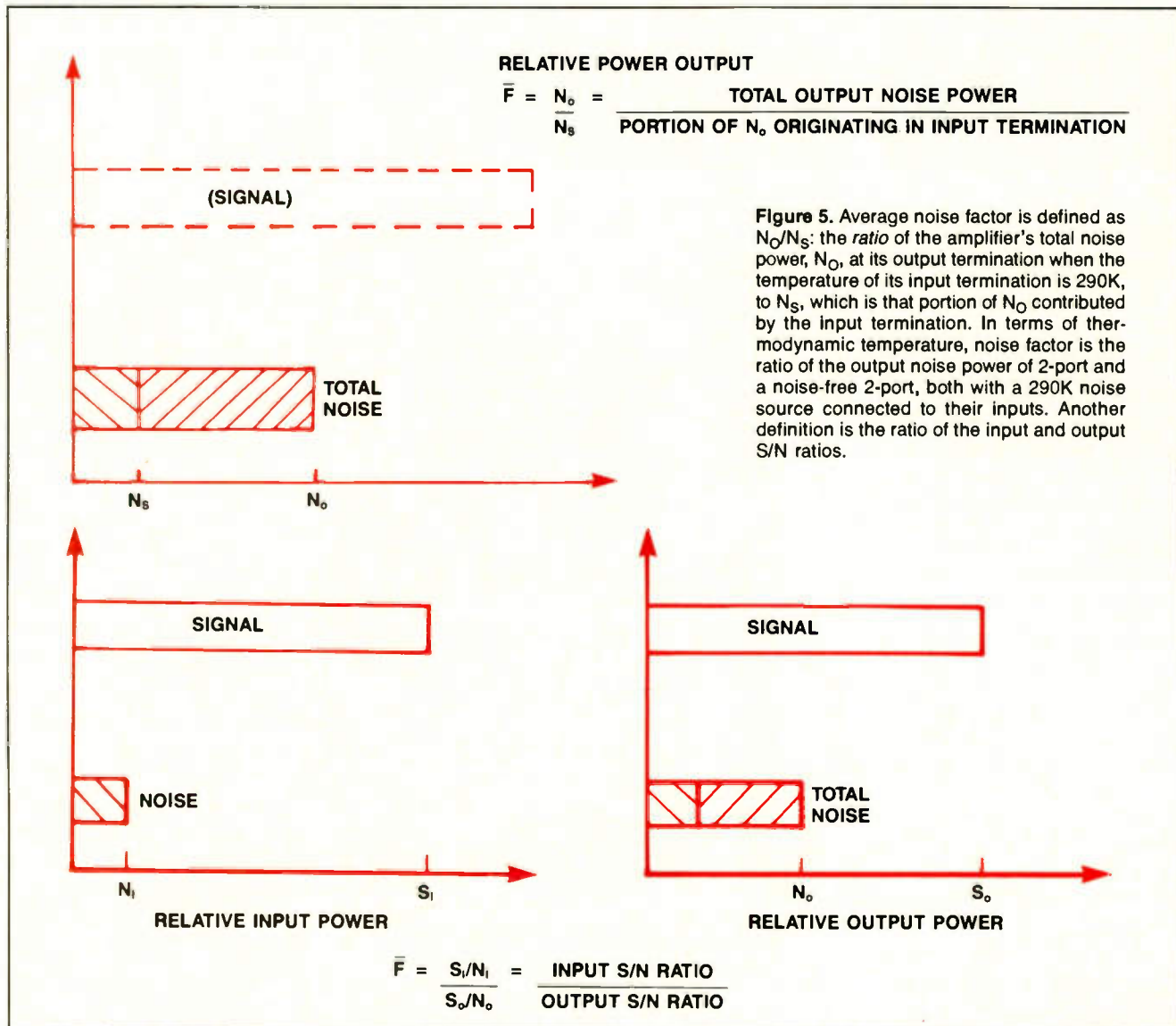

Figure 5. Average noise factor is defined as N_O/N_S : the ratio of the amplifier's total noise power, N_O , at its output termination when the temperature of its input termination is 290K, to N_S , which is that portion of N_O contributed by the input termination. In terms of thermodynamic temperature, noise factor is the ratio of the output noise power of 2-port and a noise-free 2-port, both with a 290K noise source connected to their inputs. Another definition is the ratio of the input and output S/N ratios.

of an amplifier. It is indirectly related to T_E . Noise figure means exactly the same thing as noise factor, but is commonly used to express the ratio in decibels.

Actually, the two terms are interchangeable. However, many in the technical community have adopted the practice of using the term *noise figure* exclusively to indicate the power ratio expressed in decibels, F_{dB} . Although there is nothing wrong with using the term this way, it is contrary to the intent of the IEEE committee that formulated the definition of noise factor.

Of interest here is how noise factor differs from effective input noise temperature when they are used to specify the noise rating of an amplifier. To begin with, average noise factor, \bar{F} , is a dimensionless ratio of two power ratios; average effective input noise temperature, \bar{T}_E , is a physical quantity expressed in kelvins.

Average noise factor is defined as N_O/N_S : the ratio of N_O , the amplifier's total noise power at its output termination when the temperature of its input termination is 290K, to N_S , which is that portion of N_O contributed by the input termination. Another way of saying the same thing in terms of thermodynamic temperature is to define noise factor as the ratio of the output noise powers of a 2-port and a noise-free 2-port, both with a 290K noise source connected to their inputs.

Another definition leading to the same result is the ratio of the input S/N ratio to the output S/N ratio. (See Figure 5.) Noise factor is sometimes defined as a measure of the degree to which a noisy amplifier degrades the S/N ratio of an input waveform. The input S/N ratio actually is degraded by the noise of the amplifier. The amplifier's noise, in turn, is defined as the effective input temperature, T_E .

Again, since these quantities are a function of frequency, they would be referred to correctly as *average* quantities when they are measured over a band of frequencies. Also, for the purpose of this article, we have been dealing with an active 2-port amplifier. In the general sense, however, our definitions would also apply to any transducer, which might also be a passive 2-port device or even a multipoint device. If active, its gain would typically be greater than one; if passive, its gain would be less than one. Note that if a 2-port is noiseless ($T_E = 0K$), its noise

Philips ECG's Master Guide gives you all the replacement semiconductor information you'll ever need.



For speed, accuracy and ease-of-use, nothing beats the Philips ECG* Master Guide!

- Contains technical data for 4000 Philips ECG semiconductors that replace over 240,000 industry part numbers
- Contains the most accurate cross-references available.
- New edition has 13,000 additional cross-references

and 230 new devices

All this, all in one book.

Contact your Philips ECG distributor or call 1-800-225-8326. It just might be the smartest call you make all week.

Circle (35) on Reply Card

The Smart Choice.

Philips ECG

A North American Philips Company

Ensure pinpoint accuracy with the ECG® DM-410 Multimeter.

The ECG DM-410 4½ digit multimeter ensures a level of accuracy that's hard to beat! And it's loaded with features:

- 0.05% basic DC accuracy
- 7 functions, 26 ranges
- Data hold
- 10 amps AC/DC
- Audible and visual continuity tests
- Measures down to 0.01 ohms
- RF shielded
- Diode test



Contact your ECG products distributor or call 1-800-225-8326. It just might be the smartest call you make all week.

Circle (36) on Reply Card

The Smart Choice.

Philips ECG

A North American Philips Company

Philips ECG's Cable Converter brings in the signal loud and clear!



- The TV 2000 adapts any TV set to cable ready
- Remote control adjusts volume, turns TV on/off, has direct channel selection and channel stepping
- Receives up to 139 VHF, UHF and cable channels
- Separate video and audio outputs for direct connection to VCR and stereo systems
- Stores up to 12 user-selected channels for quick selection

Contact your Philips ECG distributor or call 1-800-225-8326. It just might be the smartest call you make all week.

Circle (16) on Reply Card

The Smart Choice.

Philips ECG

A North American Philips Company

factor is one (0dB), whereas if it has a T_E equal to 290K, it has a noise factor of 2 (3dB).

Noise factor and T_E

The relationship between noise factor and effective input noise temperature can be expressed mathematically as follows:

$$T_E = 290 (F-1) \text{ or}$$

$$F = (T_E/290) + 1$$

The figure "290" in the above equations is the standard thermodynamic temperature (in Kelvins) used for noise measurements and is equivalent to about 63° Fahrenheit. Remember that F is a dimensionless number representing a ratio of two powers and that $(T_E/290)$ is also dimensionless, representing a ratio of two thermodynamic temperatures.

The average noise factor, \bar{F} , can be defined *only* when the input termination of the amplifier (that is, the transducer) is maintained at a temperature of 290K. The definition of T_E , on the other hand, is independent of the temperature of the input termination.

In addition, the average noise factor

also depends upon the impedance (or admittance) of the transducer's input termination. Noise factor, then, is not a constant of the amplifier. It changes with the impedance of the signal source, which commonly is an antenna. Because the impedance of an antenna changes with frequency, a corresponding change in the average noise factor can be expected over the frequency band of interest—another reason for specifying average noise factor.

LNA ratings

C-band LNAs typically have noise temperature ratings of 75K to 120K, with 100K being the most common rating for effective input-noise temperature. The corresponding noise factor/noise figure range is 1.0dB to 1.5dB—a very small spread—with 100K corresponding to approximately 1.3dB. You can only assume that because of the very small numbers involved, the TVRO industry found it more convenient to express the noisiness using effective input noise temperature in kelvins rather than to use noise figure in dB.

Note, however, that at Ku band, the noise levels are considerably higher—more like a 2.5dB noise figure, which

corresponds to a 226K effective input noise temperature. Because the noise figures are larger and, therefore, more conventional, the industry apparently has elected to use noise-figure ratings on Ku-band LNAs instead of continuing to use noise temperature. On the other hand, marketers of LNAs may not want to risk the chance of receiving a poor image from their dealers and distributors who, not understanding the concept of noise temperature, might consider a device having such a high noise-temperature rating (when compared to C-band LNAs) to be inferior.

Summing it up

Apparently, the TVRO industry, in specifying the "noisiness" of a low-noise 4GHz amplifier, has elected to use the concept of effective input noise temperature. This concept employs a thermodynamic temperature (in kelvins) to define a noise power at the input termination of an equivalent noiseless amplifier, which produces at its output termination a noise power equivalent to the output noise power of the actual amplifier when its input termination is maintained at 0K (that is, noiseless). This amplifier noise may also be expressed as the noise factor: a dimensionless ratio of output noise power to input noise power when the input termination is maintained at 290K. The noise figure may be expressed in decibels by multiplying the logarithm of the power ratio by 10.

Unfortunately, *noise figure* appears to be the preference of those marketing the new 12GHz LNAs for use with Ku-band hardware. This choice can only cause further confusion among prospective purchasers of TVRO hardware who have only recently felt comfortable with the term *noise temperature*. Now, the industry is doing a flip-flop, which has the potential to engender a certain amount of indignation and disloyalty among those people even if they understand the dual concepts of noise temperature and noise figure. Furthermore, using noise figure to characterize a TVRO system is meaningful only if the admittance (or impedance) of the input termination is specified. So, it would seem more logical, rational and certainly more consistent to remain with the input-noise-temperature specification that has been used to spec C-band LNAs and LNAs. Let us hope that a measure of reasonableness will pervade in the marketplace.

Glossary

C-band: The microwave frequency band from 3.7GHz to 4.2GHz.

Ku-band: The microwave frequency band from 11.7GHz to 12.2GHz.

LNA: Low-noise amplifier. An amplifier that is designed to contribute the lowest possible amount of noise to an amplified satellite signal. This antenna pre-amplifier is located directly at the antenna so that the very small satellite signal is amplified before any attempt is made to transmit it to the TV system.

Noise temperature: This specification, the effective input noise temperature, T_E , is a measure of the noisiness of an amplifier and represents how much noise

power the amplifier adds to its input signal when observed at the output termination. T_E is a *fictitious* temperature that is expressed in kelvins (K) and is related to the input termination of an amplifier.

Transponder: From the words *transmitter* and *responder*, this electronic device automatically transmits a signal in response to reception of a signal.

Noise factor: A power ratio, F, widely used to designate the noisiness of an amplifier. It is indirectly related to T_E .

Noise figure: Exactly the same thing as noise factor, but commonly used to express the ratio in decibels.

GE MODEL 1VCR2006W Y/C (LUMINANCE AND CHROMA) SCHEMATIC DIAGRAM

This schematic is for the use of qualified technicians only. This instrument contains no user-serviceable parts.

Use of substitute parts that do not have the same safety characteristics as recommended in factory service information may create shock, fire, excessive x-radiation or other hazards.

Product safety should be considered when component replacement is made in any area.

Critical parts in the power circuit block should not be replaced with other makes. Critical parts are indicated by a !. It is recommended that only exact cataloged parts be used for replacement of these components.

Critical parts in the power circuit block should not be replaced with other makes. Critical parts are indicated by a !. It is recommended that only exact cataloged parts be used for replacement of these components.

July 1988

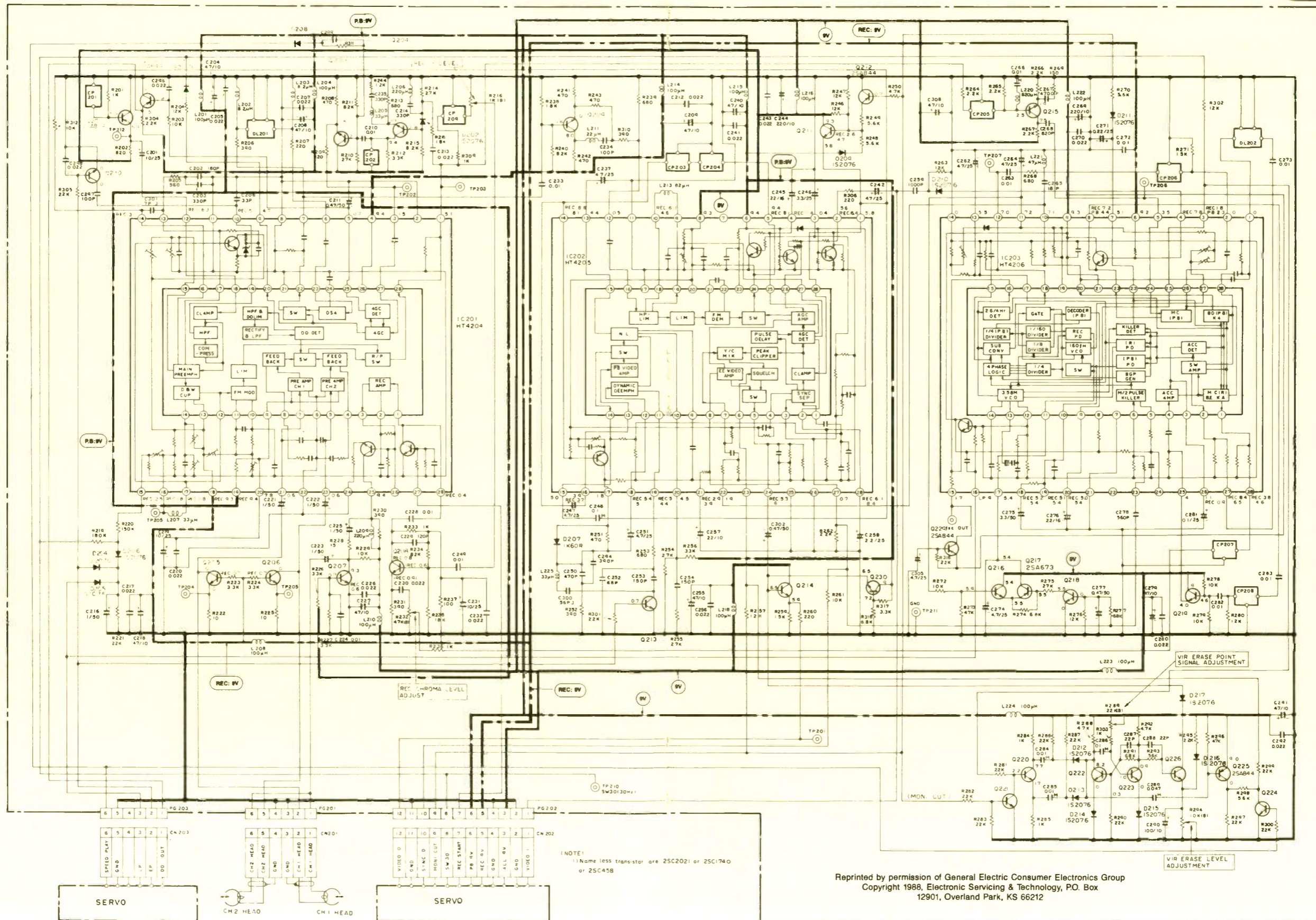

GE MODEL 1VCR2006W SERVO SCHEMATIC DIAGRAM

GE MODEL 1VCR2006W SERVO SCHEMATIC DIAGRAM

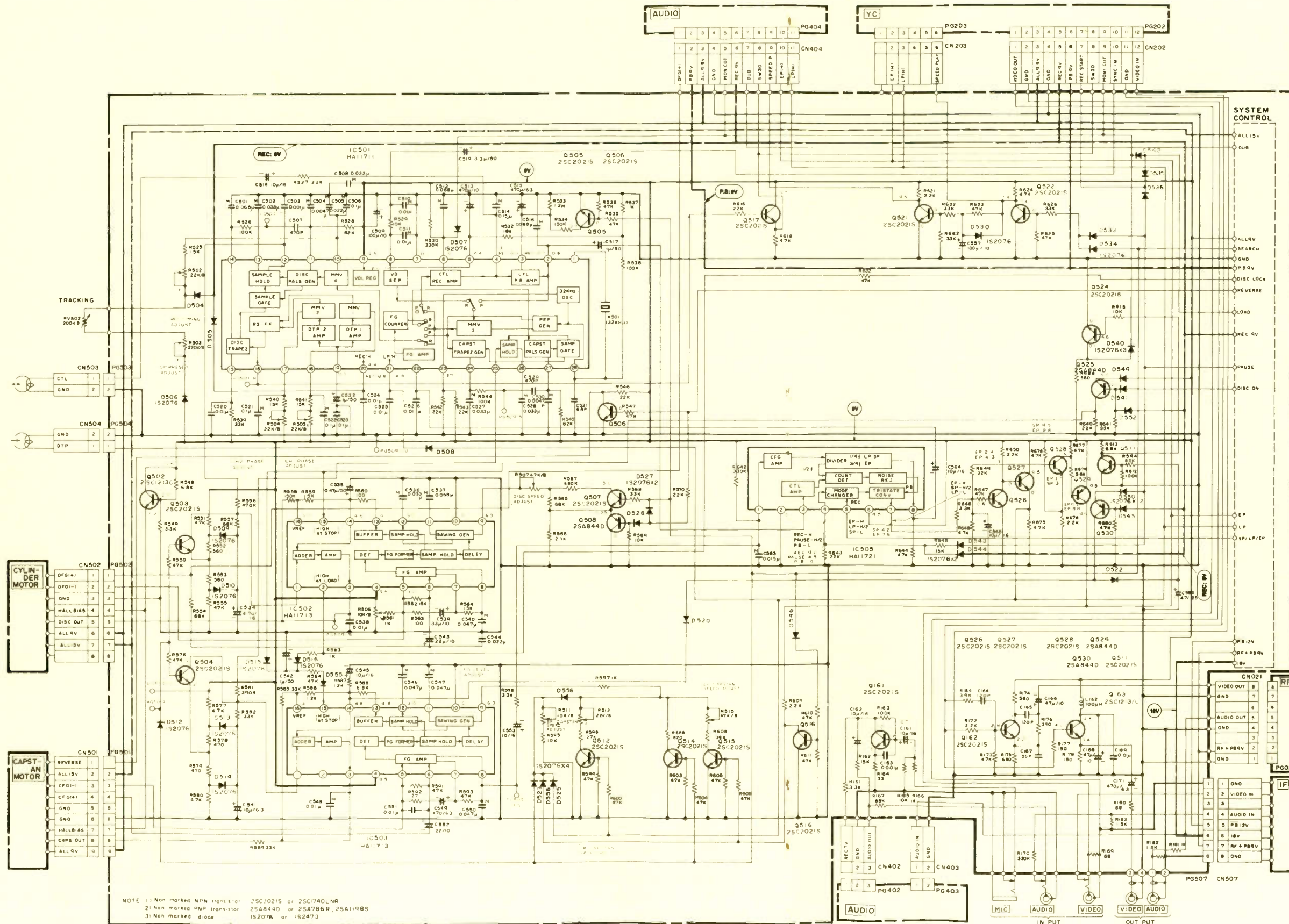

Product safety should be considered when component replacement is made in any area. Critical parts in the power circuit block should not be replaced with other makes. Critical parts are indicated by a !. It is recommended that only exact cataloged parts be used for replacement of these components.

Use of substitute parts that do not have the same safety characteristics as recommended in factory service information may create shock, fire, excessive x-radiation or other hazards.

This schematic is for the use of qualified technicians only. This instrument contains no user-serviceable parts.

NOTE 1) Non marked NPN transistor 2SC2025 or 2SC1740LNR
 2) Non marked PNP transistor 2SA844D or 2SA786R, 2SA1198S
 3) Non marked diode 1S2076 or 1S2473

GE MODEL 1VCR2006W VCR SYSTEM CONTROL SCHEMATIC DIAGRAM

GE MODEL 1VCR2006W VCR SYSTEM CONTROL SCHEMATIC DIAGRAM

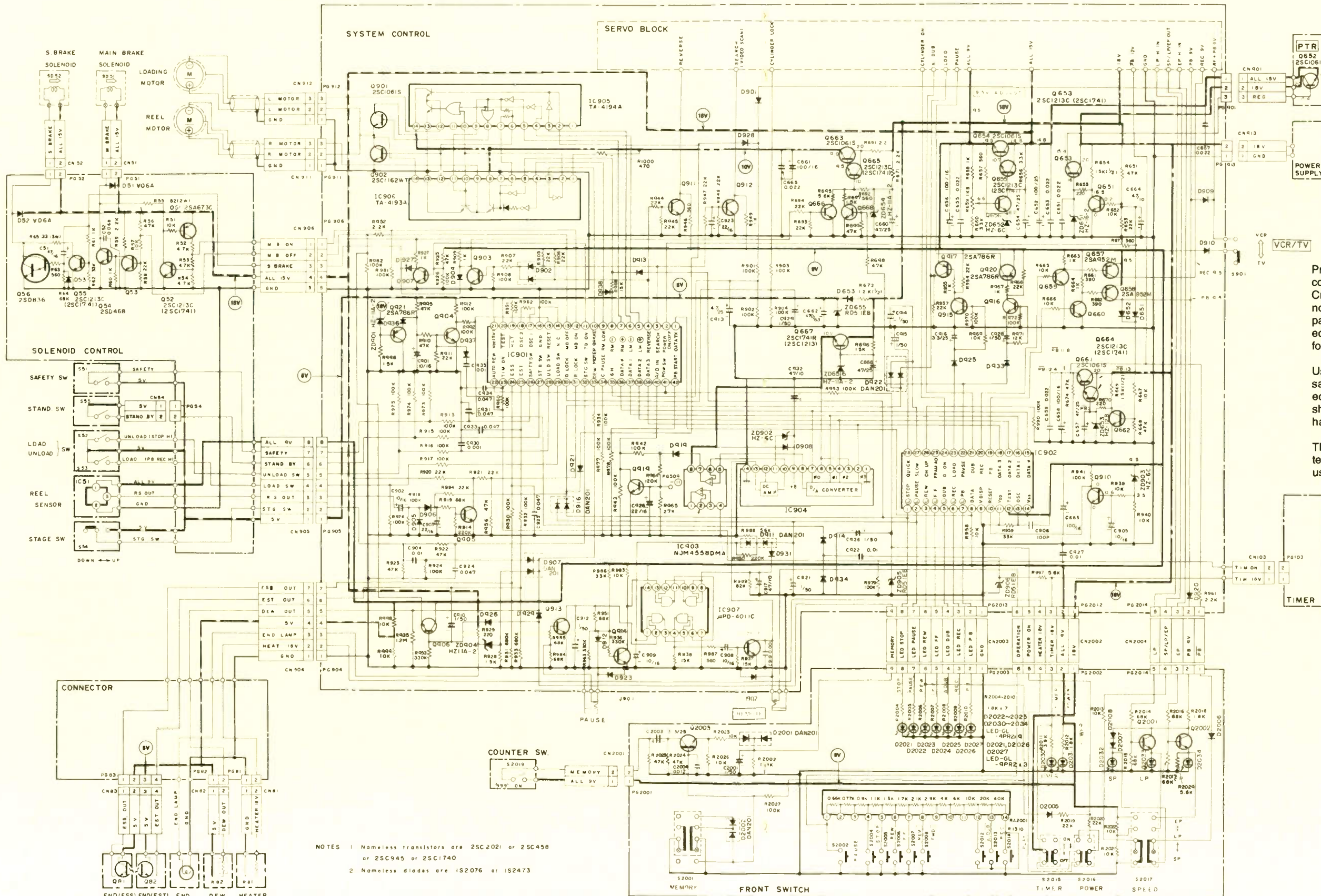

Product safety should be considered when component replacement is made in any area. Critical parts in the power circuit block should not be replaced with other makes. Critical parts are indicated by a !. It is recommended that only exact cataloged parts be used for replacement of these components.

Use of substitute parts that do not have the same safety characteristics as recommended in factory service information may create shock, fire, excessive x-radiation or other hazards.

This schematic is for the use of qualified technicians only. This instrument contains no user-serviceable parts.

- NOTES
- 1 Nameless transistors are 2SC2021 or 2SC458 or 2SC945 or 2SC1740
 - 2 Nameless diodes are 1S2076 or 1S2473

Zenith CM-139/B-0 (B) chassis color TV

July 1988

ES&T Manufacturers' schematics PROFAX

July 1988 Schematic General Electric VCR, model 1VCR2006W 3027

Zenith Color TV, chassis CM-139/B-0 (B) (D0920A, D0920D, D0920K, D0920U, D0930S) . . . 3028

Reprinted by permission of Zenith Video Tech Corporation Copyright 1988, Electronic Servicing & Technology, P.O. Box 12901, Overland Park, KS 66212.

Product safety should be considered when component replacement is made in any area of a receiver. The shaded areas of the schematic diagram designate the components in which safety is of special significance. It is recommended that only exact cataloged parts be used for replacement of these components.

Use of substitute parts that do not have the same safety characteristics as recommended in factory service information may create shock, fire, excessive x-radiation or other hazards.

This schematic is for the use of qualified technicians only. This instrument contains no user-serviceable parts.

SYSTEM SCHEMATIC

A system schematic is a hybrid troubleshooting aid consisting of a functional block diagram and simplified module schematics. It provides an overview for tracing major circuits and includes these features: key voltages, the makeup of individual cables, all connections between modules and assemblies, major components and the main lines of interaction related to these components.

The intention of the system schematic is to provide sufficient information to analyze the TV as a system for determining which major component is faulty. For complete module and assembly schematics, refer to the appropriate service manual.

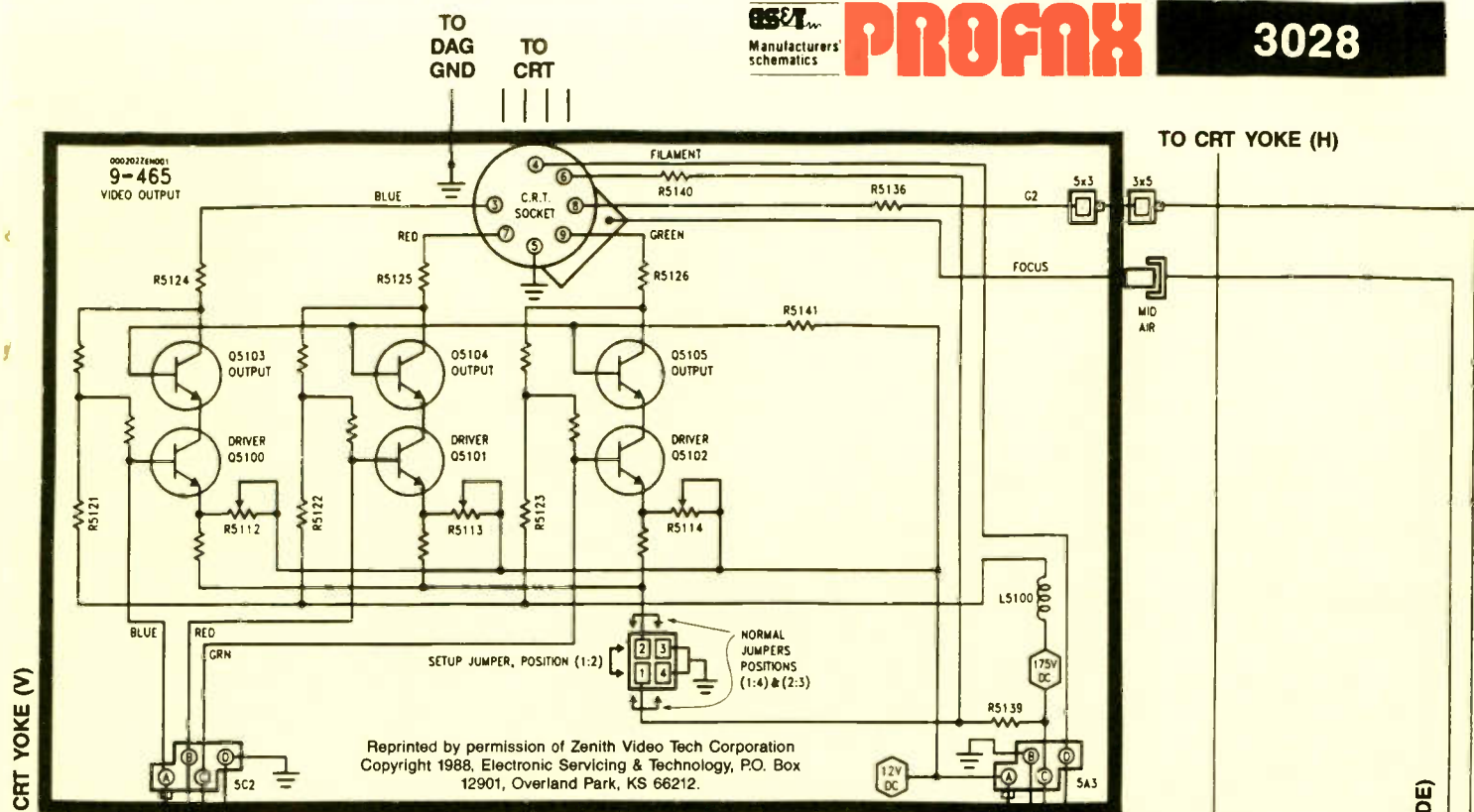

Reprinted by permission of Zenith Video Tech Corporation Copyright 1988, Electronic Servicing & Technology, P.O. Box 12901, Overland Park, KS 66212.

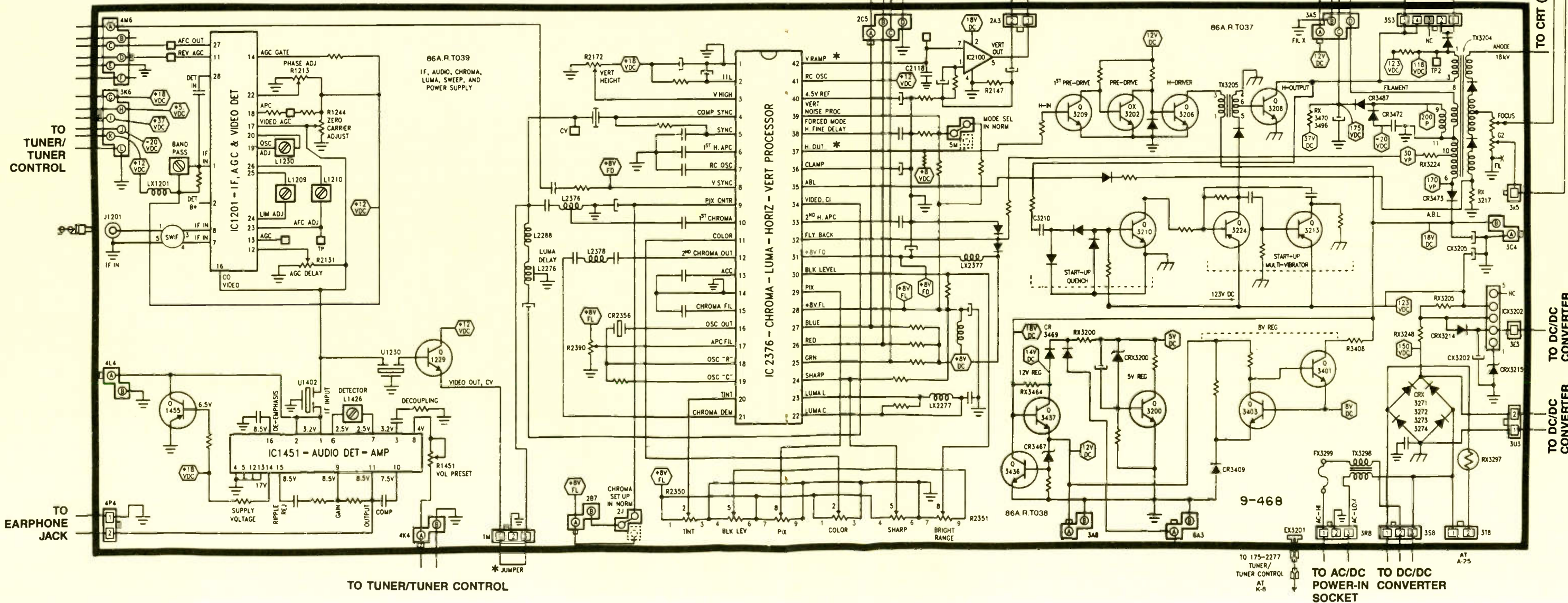

TO TUNER/TUNER CONTROL

TO EARPHONE JACK

TO TUNER/TUNER CONTROL

TO AC/DC TO DC/DC POWER-IN CONVERTER SOCKET TO DC/DC CONVERTER TO DC/DC CONVERTER TO CRT (ANODE)

SYMCURE/ Troubleshooting Tips guidelines

ES&T is now paying \$60 per page (six different cases of symptoms and their solutions) for accepted Symcure submissions.

The term *Symcure* is a contraction of two words: symptom/cure. Problems that are published in the Symcure department are those that have occurred more than once.

This is the kind of problem you can solve without even a second thought because you've already seen so many of that particular brand and model of set with those symptoms; in almost every case, it will be the same component that fails or the same solder joint that opens.

It is preferred that you submit six or seven symptoms and cures for a single TV model.

ES&T is also paying \$25 per item for accepted Troubleshooting Tips.

A Troubleshooting Tip describes a procedure used to diagnose, isolate and correct an actual instance of a specific problem in a specific piece of equipment. Its value, however, lies in the general methods described.

A good Troubleshooting Tip has the following elements:

- It should be a relatively uncommon problem.
- The diagnosis and repair should not be obvious and should present something of a challenge to a competent technician.
- It should include a detailed, step-by-step description of why you suspected the cause of the problem and how you confirmed your suspicions—anything that caused you to follow a false trail also should be included.
- It should describe how the repair was performed and any precautions about the possibility of damage to the set or injury to the servicer.

For Symcures and Troubleshooting Tips, please also include:

- the manufacturer's name;
- the model and chassis number;
- the Sams Photofact number;
- and
- a sketch of the schematic area where the fault was found. (Include a major component such as a transformer or transistor to provide a landmark for the ES&T staff.)

NEW SERVICES FROM PTS

TUNERS



Varactor
Front ends
Standard

MODULES



Mother boards
Single function
Manufacturer's Updates

VCR

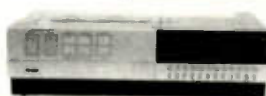

VHS
Beta
Portables

TVRO

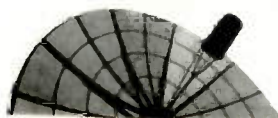

Receivers
Actuators & Arms
Down converters

■ PTS wants your repair business. And they have made some big changes at servicenters nationwide. New test equipment. New quality assurance programs. Even faster express service! And a new 800 number to serve you better. Call PTS today.

THE NEW

PTS

1-800-441-2371

Ask for the servicenter or distributor nearest you.

PTS Corporate Headquarters
P.O. Box 272
Bloomington, Indiana 47402

Circle (17) on Reply Card

Test your electronics knowledge

By Sam Wilson, CET

1. Which of the following is most similar to nepers?

- (A) SOMES
- (B) PHONS
- (C) decibels
- (D) centimeters per cubic inch

2. Refer to the direct-coupled circuit in Figure A. If the emitter of Q_1 is shorted to its base, will Q_2 be destroyed?

3. Disregarding the tracks for the luminance and chroma signals on a VCR tape, name two other tracks found on the tape.

4. In what part of a radar system would you expect to find a duplexer?

5. Using the expanded sweep, the rise time of a square wave is obtained as

shown in Figure B. Assuming the sweep has been calibrated for $15\mu\text{s}$ per division, what is the rise time of the square wave?

6. Assume that the square wave in the previous question has passed through an amplifier. If the scope is assumed to have a vertical amplifier of infinite bandwidth, what is the approximate bandwidth of the amplifier that passed the square wave?

7. In a weak signal area, a pre-amplifier should be located as close as possible to

- (A) the lightning arrester.
- (B) the receiver.
- (C) the antenna.
- (D) the ac power line

8. For a Class B amplifier like the one in Figure C, which has no input signal, the collector voltage should be

- (A) equal to the supply voltage.
- (B) half the power-supply voltage.
- (C) one-third the power-supply voltage.
- (D) about 0V.

9. If the frequency numbers on your AM radio are crowded on the right side, you could change them to even spacing by

- (A) using a higher local oscillator frequency.
- (B) using a lower local oscillator frequency.
- (C) increasing the inductance in the tuned circuit.
- (D) None of the above.

10. Is the following statement true? "In a superheterodyne receiver, the local oscillator frequency must always be *above* the incoming frequency."

Wilson is the electronics theory consultant for ES&T.

Answers are on page 63.

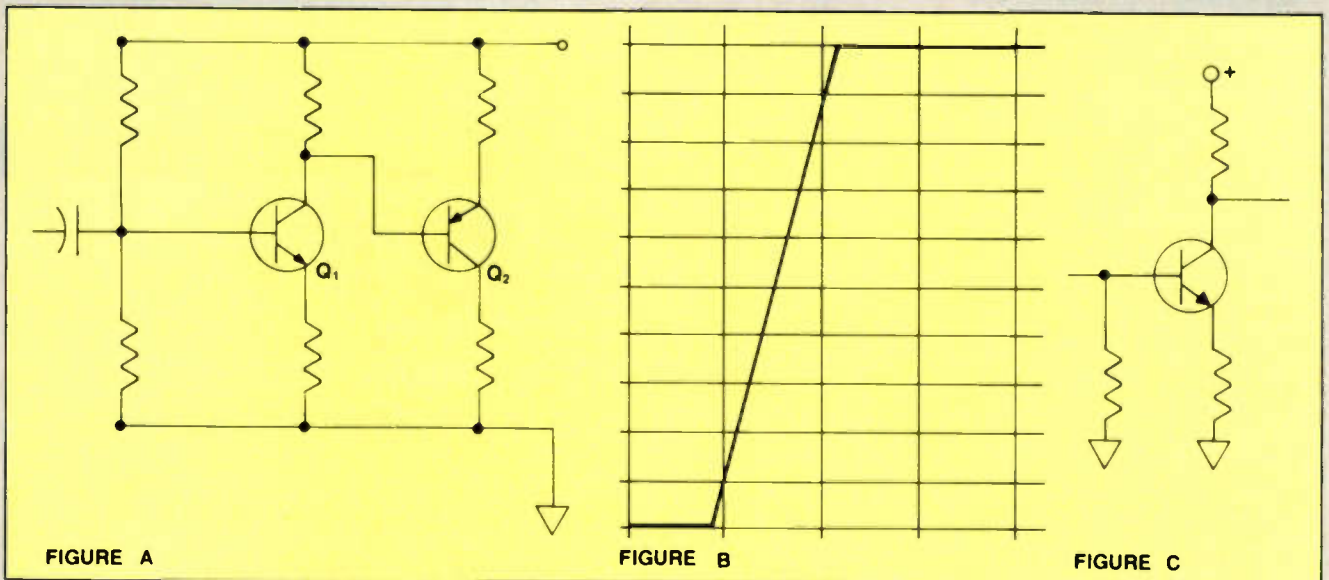

Test and measurement equipment catalog

Anasco's 1988 catalog of laboratory and field-service test and measurement equipment introduces more than 75 new products ranging from full-function DMMs to digital storage oscilloscopes. It provides complete specs for more than 400 items.

Circle (126) on Reply Card

Tool/test equipment catalog

An illustrated buying guide of electronic tools, test equipment and supplies for the manufacture, assembly and repair of electronics is now available from HMC. The guide includes test instruments, prototyping equipment, tool kits, soldering/desoldering systems, lamps and magnifiers, anti-static products and hand tools.

Circle (127) on Reply Card

Battery catalog

Products distributed by Batt-Tronic are now featured in its 12-page, 1988 summer catalog. Everything from batteries and findings to tools-of-the-trade are included. The catalog also highlights sales training, inventory control and reclaim services.

Circle (128) on Reply Card

Digital panel indicator brochure

A 24-page brochure describing a line of digital panel indicators has been introduced by Beckman Industrial. The brochure covers everything from low-cost, basic measurement and digital display models to application-specific models with alarms, trend outputs and digital communications. Products included are 50, 400A, 500T and 500 series.

Circle (129) on Reply Card

Problem-solving bulletins

Microwave Filter Company has introduced two bulletins for eliminating interference in certain applications. Bulletin 03 describes how to eliminate interference FM stations may cause to other broadcasters. Bulletin 04 describes solutions for eliminating paging transmitter interference in CATV and MATV systems.

Bulletin 03 details the three types of interference, the symptoms they cause and the types of filters that correct the problem. Bulletin 04 discusses fundamental overload, harmonic in-

terference, non-antenna ingress and the filters and techniques to solve these problems.

Circle (130) on Reply Card

Test equipment brochure

Simpson Electric Company is offering a brochure that highlights the Professional series of test equipment. The six-page brochure lists operating specifications and features of Simpson

models 712, 713, 714, 421, 422 and 560.

Circle (131) on Reply Card

Workbench accessories catalog

The PM-57 catalog from Desco shows the company's line of workbench accessories. Several new items have been added, such as a sleeving cutter, soldering iron tip cleaners, a solder sucker and heat sinks.

Circle (132) on Reply Card



CALL TOLL FREE

Include work address and phone number for Free Catalog.

800-824-2873

DIGITAL MULTIMETERS

BECKMAN

Beckman Industrial!

- All 300, HD, and Circultmate series
- All accessories in stock

MODEL	PRICE
HD100	\$169
HD110	\$199
HD130	\$259
HD140	\$279
300	\$120
310	\$145
310B	\$155
320	\$179
320B	\$189
330	\$219
350	\$229
360	\$289
4410	\$239

FLUKE

- Autorange Analog display
- Touchhold function
- 0.3% accuracy Heavy duty

MODEL	PRICE	MODEL	PRICE
21	\$ 99	75	\$119
23	\$149	77	\$149
25	\$199	8010A	\$299
27	\$259	8012A	\$359
37	\$249	8020B	\$219
52	\$169	8024B	\$259
73	\$ 79	8050A	\$399

Hand held DMM

FLUKE 23YEL

SALE \$120

LIST \$145

WAYNE KERR

MODEL	PRICE
4210	\$2650
4225	\$1950

SCOPES

HITACHI

Hitachi

Denshi America, Ltd.

- All 20 models in stock
- 2-3 year warranties
- 20-100 MHz

MODEL	PRICE
V209	\$ 895
V222	\$ 530
V422	\$ 740
V425	\$ 796
V660	\$ 985
V665	\$1255
V680	\$1341
V1060	\$1345
V1065	\$1615
V1100A	\$2116

HITACHI V-509

Portable Dual Trace Scope

SALE \$1199

LIST \$1445

IWATSU



- All 14 models in stock
- 2-3 year warranties
- 20-250 MHz

MODEL	PRICE
5702	\$ 535
5705	\$ 899
5706	\$ 749
5710	\$1245
5711	\$1695
5712	\$2999

POWER SOURCES

POWER DESIGNS

- Low and high voltage power sources
- 1-5 year warranties

MODEL	PRICE
TP340	\$ 805
TP343A	\$ 855
TW347D	\$ 855
TW5005D	\$ 625
TW6050D	\$1075
2K20A	\$1095
2020B	\$ 850
4050D	\$ 805
5020	\$ 925
6010D	\$ 495
6150	\$ 775

USED TEST EQUIPMENT, TOO!—OVER 3,000 MODELS AVAILABLE AT HUGE DISCOUNTS WITH WARRANTIES!

■ Quantity Discounts Available ■ Dealers Welcome ■ Freight and Tax Extra ■ Immediate Availability of Equipment

US United States Instrument Rentals, Inc.

A U S Leasing Company
2988 Campus Drive
San Mateo, CA 94403

Circle (18) on Reply Card

The basics of static control

By Mike Voss

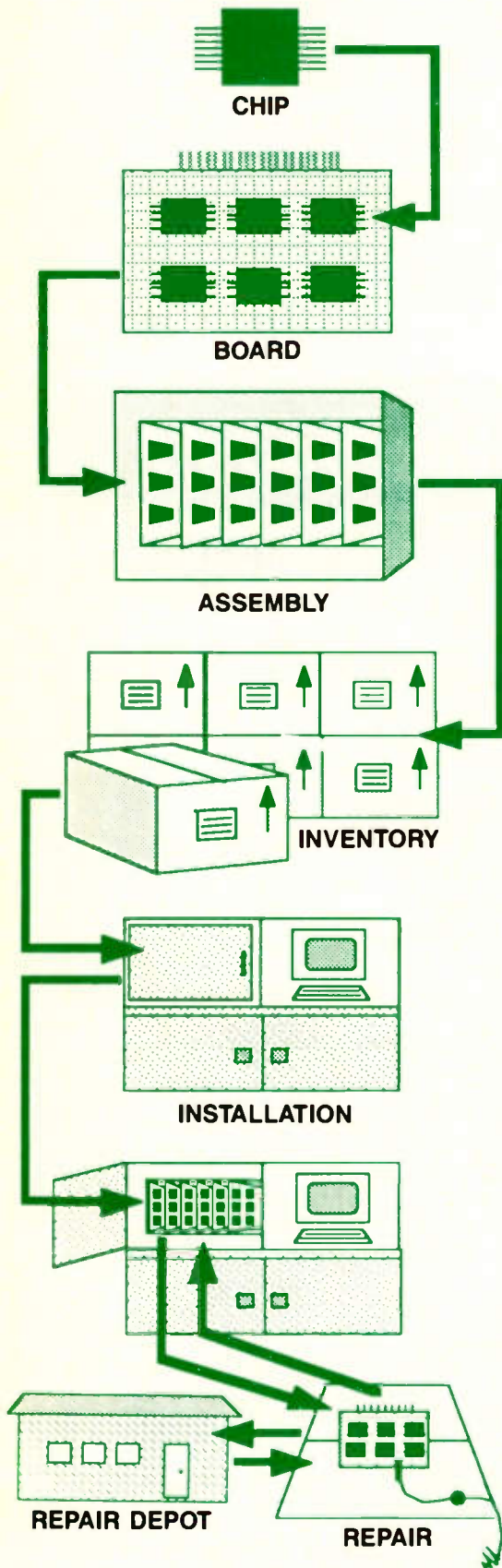

Figure 1. During the life cycle of a static-sensitive device, there are many chances for static discharge to damage the component. This sequence shows how frequently each device is vulnerable to static damage.

Imagine this scenario—an electronics servicing technician, wearing synthetic clothing, walks across a carpeted floor and sits down at an uncovered workbench littered with a used plastic-foam coffee cup, some empty cardboard boxes, maybe a few notes scribbled on unused work-order slips. Then he touches an electronic product that was brought in with only minor problems.

In the old days of electronics servicing, that scenario might not have been a problem. Today, however, such a scenario invites static electricity or *electrostatic discharge* (ESD) damage, which poses an invisible but very real threat to electronic equipment. In servicing a minor problem, the technician may inadvertently create a new, major problem—blown chips, shorted diodes, degraded components. New technology, such as metal-oxide semiconductors and radically down-sized microprocessor chips, requires new servicing methods, and static control has become a major concern for electronics servicers.

Training—an ongoing process

Although static-control programs have been a fact of life in the electronics industry for more than a decade, many people in the sequence of equipment design, manufacturing, assembly, transport, installation and service have only a limited understanding of the problem and its solutions. Add to that the fact that new and untrained people join the workforce each year, and it's clear that training is not a one-time effort—it must be an ongoing process.

A high level of awareness by service technicians is unquestionably one of the

most critical elements in a static-control process. Unless the technicians have a good understanding of the problems, it is unlikely that they can avoid making costly static-control errors.

There are three basic rules for static-control:

1. Handle all static-sensitive components only at a static-safeguarded work station.
2. Transport all static-sensitive components only in static-shielding containers or packages.
3. Make sure your suppliers follow rules one and two.

Vendor contact

Appropriate static-control field procedures can only preserve the level of product quality that exists when the servicing technician takes over responsibility for a piece of equipment. Thus it is important that the equipment vendors' static-control process be satisfactory as well.

Even components in equipment that works properly when new may have suffered what is known as *latent static damage*. The components may test in the acceptable range, but problems will occur during actual service.

A complete static-control process

Electronic devices require protection from static discharge, beginning at the component level and ending only when the equipment is replaced. There can be no weak links or lapses in the process.

Figure 1 illustrates the life cycle of a typical static-sensitive circuit chip in a commercial computer system. The steps in this process are not new, but the sequence shows how frequently each device is vulnerable to static damage.

The chip begins life as a silicon sub-

Voss is market development manager of 3M Static and Electronic Control Division, a manufacturer of static-control products.

strate onto which multiple layers of oxides and conductive materials are screened in a microscopic and precise process. Its electronic job description may involve handling high-speed signals at low voltage levels, making it susceptible to damage from both static discharge and static fields. To guard against static problems, chip manufacturing takes place in a clean-room environment with grounded, conductive work surfaces.

Individual chips are then packaged in plastic or ceramic housings, with leads bonded to pins or pads on the housing, again under conditions that protect against static buildup. Completed circuits are generally stored and handled in conductive plastic sleeves, commonly referred to as *DIP tubes* (DIP is the abbreviation for dual-in-line, the IC package that has two parallel rows of pins on it). Individual pins may be shorted together with conductive foam for protection when the devices are not in DIP tubes.

Next, the static-sensitive circuit is inserted into a socket or mounted on a circuit board and soldered in place. Whether manual or automated, this process requires continuing care to avoid static damage. The normal movement of people in a work environment can easily generate static levels of 25,000V or higher. Even handling a seemingly innocuous plastic-foam coffee cup at a work station can produce damaging static charge. Conductive floor and benchtop mats, grounded wrist straps, grounding shoe straps, conductive foam, static-dissipative bags and conductive plastic carriers protect boards during this phase.

Finished circuit boards are then placed in an equipment cabinet or cir-

Understanding static

A static charge is the result of an excess or deficiency of electrons on a surface. The relative amount of electron imbalance determines the static charge level. Simply stated, a charge is generated by physical contact between, then separation of, two materials. One surface loses electrons to the other.

The types of materials involved and the speed and duration of motion between them determine the charge level. Common non-conductive plastic packaging materials such as polyethylene, polystyrene or mylar films are particularly prone to this electron imbalance.

Even relatively low levels of static electricity can destroy or degrade certain electronic components. Sensitive devices include metal oxide semiconductor (MOS) devices, junction field-effect transistors, diodes, thick-film resistors and

various bi-polar circuit elements. The typical ranges of static susceptibility for such devices are listed in Table 1.

These kinds of devices are manufactured with multiple oxide layers with tolerances measured in millionths of an inch, and are designed to operate at low voltage levels. Static electricity can create shorts, opens or changes in critical performance values, and the damage is frequently such that it may not surface unless the device is called on to operate at or near its rated load.

Electrostatic discharge that occurs during the handling of a device is the most obvious form of damage. However, many devices can be ruined or degraded without direct contact or noticeable spark. The key is to protect a component at all times from static and voltage fields exceeding its rated breakdown voltage.

Table 1.

Static susceptibility

Type	Typical susceptibility level
MOSFET	100V to 200V
JFET	140V to 10,000V
CMOS	250V to 2,000V
Schottky Diode	300V to 2,500V
Polar Transistor	380V to 750V
ECL	500V
SCR	680V to 10,000V

An ESD tool kit

ESD precautionary requirements for electronic technicians are very similar for field technicians and bench technicians, but they do vary slightly because of differing job requirements. For a well-equipped technician, the items listed below are standard parts of a servicing tool kit. For assured protection against ESD damage, the technician should always use these protective products when handling or servicing a piece of equipment. This rule applies particularly to computer-servicing technicians, but it is instructive for any technician who services modern, static-sensitive circuits.

Field technicians

Technicians should use the following items when servicing electronics in the field:

- a static-dissipative field service kit or mat.
- a conductive wrist strap and ground lead.
- a static-dissipative lab coat.
- metalized, static-shielding bags.
- conductive PCB transport containers.
- conductive or static-dissipative footwear.

The field technician should begin a service job by wearing a static-dissipative lab coat and conductive footwear to suppress any static charge that has built up on his body. Conductive or static-dissipative footwear helps to prevent the charge generation that occurs through normal body movements. Next, the technician should put on a conductive wrist strap and attach the ground lead to a known ground. Chassis ground should not be used because the quality of that ground source is not readily known. The static-dissipative field service kit or mat should then be unrolled and connected to ground for use as a temporary work surface. At this point, actual service can begin, with all work performed on the mat or field service kit. If PCBs must be taken back to the shop or depot for further servicing, they should be placed in

a static-shielding bag, sealed and then placed in a protective container.

Bench technicians

Technicians who service electronics on the bench need the following items on hand:

- a static-dissipative work surface/table mat.
- a conductive wrist strap and ground lead.
- a static-dissipative lab coat.
- metalized static-shielding bags.
- conductive floor mats/runners.
- an ionized air blower/static neutralizer and static charge monitor.
- a continuous wrist-strap monitor
- conductive or static-dissipative footwear.
- conductive totes.

Bench technicians have the advantage of a permanent work area that can be made static-safe if proper precautions and work methods are used. Conductive/static-dissipative floor and table mats help to discharge static from charged, conductive objects that are brought into contact with the mat. Static-shielding bags and conductive totes serve to protect the product from ESD while in transport. Wrist straps, conductive footwear and static-dissipative lab coats aid in discharging static charges from personnel. The wrist strap should be connected to a continuous monitor to alert the technician to wrist-strap or ground-lead failures and improper use by the operator. Finally, an ionized air blower should be used to dissipate static charges from non-conductive objects. The air ionizer provides equal quantities of positive and negative ions in a heated air stream. Ions are attracted from the air stream to a charged object until the charge is neutralized.

There is no single ESD protection product that will provide all-encompassing protection. Rather, it is up to a combination of products, personnel practices and employee awareness of proper ESD precautions to prevent component damage.



Circuit boards should only be tested or repaired at properly static-safeguarded workstations, which should include wrist straps, air ionizers, static-dissipative floor and table mats, and static-dissipative clothing.

circuit card frame. During this process, workers exercise static precautions by using grounded work surfaces, grounded clips and wrist straps.

Once a system has been assembled and is packaged for storage and shipment, sensitive circuits enjoy fairly good static protection. However, certain precautions, such as the use of static-shielding cushioning materials, may still be appropriate.

Installation of the new equipment demands continuing vigilance. A grounded wrist strap must be worn by the technician during setup or adjustment. Precautions during the actual day-to-day use of the system may require other static-control products such as grounded floor mats or conductive, self-adhesive keyboard strips, depending on the environment and the system.

When equipment repair is required, boards should be removed from the equipment housing only with the pro-



During inventory and shipping, precautions, such as the use of static-shielding bags, can protect electronic devices and circuit boards from ESD damage.

tection of a static-protective service kit, including a grounded wrist strap. Boards to be sent back to the manufacturer or to a module repair company for rework should be placed in a static-shielding bag.

If a replacement board is ever carried to the job site, it should be packaged in static-shielding bags and should also be carried in a conductive transport case. The boards should be removed only under the protection of a properly used field service kit.

Static damage is usually invisible and undetectable. However, with uninterrupted care in handling, the life cycle of a static-sensitive device can be long and productive. Each person involved in the equipment production, handling, operating and maintenance sequence has to be responsible for static protection.

Keeping your protection current
Each product used for static control

has a specific task that demands a certain level of performance. Each should be tested periodically to confirm that its function is being fulfilled.

For example, after a period of time, wrist straps may no longer be able to provide a good electrical interface between the conductive surface and the skin of the wearer. The integral current-limiting resistor or snap connector can also malfunction after repeated use.

The same is true with portable field service kits, static-protective bags and other conductive items. These components should be checked periodically with a megohmmeter, and users should be alert to loose grounding lugs, cracked conductive containers and torn conductive bags.

An effective static-control procedure is rather like an automobile safety belt. Its use must become habitual by everyone to protect common interests.



VCR IDLER TIRES



Now you can do VCR repairs faster and easier than ever before. **Parts Express** is now offering the most comprehensive idler tire kit available. With this kit in your stock room you can do over 90% of idler assembly repair jobs without waiting for parts deliveries.



FREE
cross-reference
included

The kit includes a **FREE** cross-reference listing over 80 manufacturer assembly numbers and over 200 model numbers. 150 tires total, 10 each of 15 different sizes in a high quality storage case with separate compartments for each size. Worth over \$400 retail value.

\$55⁰⁰

#400-900

VCR IDLER ASSEMBLIES



Part #	Replacement for	(1-9)	(10-up)
430-010	Sharp NIDL0005	4.15	3.70
430-020	Sharp NIDL0006	4.35	3.90
430-030	Sharp NPLY-V0051	4.15	3.70
430-050	Pana VXPO329	1.40	.95
430-052	Pana VXPO344	1.40	.95
430-055	Pana VXPO401	1.95	1.55
430-060	Pana VXPO521	4.50	3.90
430-100	Fisher 4204-00300	7.80	6.90
430-105	Fisher 4804-00100	1.50	1.25
430-110	Fisher 4904-00900	7.50	6.75
430-120	RCA 164113	3.75	2.95
430-125	RCA 150614	3.95	3.25
430-130	HIT 6413111	5.20	4.65

**FREE
CATALOG**



**Parts
Express**
International Inc.

**CALL TOLL FREE
1-800-338-0531**

340 E. First St., Dayton OH 45402
Local—1-513-222-0173

Circle (19) on Reply Card

What do you know about electronics? --

Modulating pulses

By Sam Wilson, CET

Electronic equipment is similar in at least one way to humans: It works more efficiently if you give it periodic breaks. For that reason, pulsed equipment is more efficient than analog equipment, which is one reason why digital equipment is favored over analog equipment in many applications.

Switching equipment ON and OFF does not automatically make it digital, but it is sometimes difficult to draw the line between pulse and digital systems.

One simple distinction is that with digital equipment, digital codes perform some function. Pulse equipment uses pulses that are not related to digital or numeric values.

Some time ago (January 1987), I discussed the idea behind pulse-code modulation, which doesn't fit exactly into either of the simplified definitions above. With pulse-code modulation, various amplitudes of an analog signal are converted to binary codes. Those codes are easily stored, as in the case of compact discs. Playback involves converting the numeric codes back to the original analog waveform.

Other methods can be used to convert an analog signal into pulses that can be used for storage or communications. A few examples are given in the following paragraphs.

Pulse amplitude modulation (PAM)

Figure 1 shows how a sine wave can be converted to a pulse-amplitude signal. As with other pulse-modulation systems, the pulsed version is more efficient. The system in Figure 1 can be bothered by electrical noise pulses because the receiver is designed to respond to various amplitudes. The receiver,

Wilson is the electronics theory consultant for ES&T.

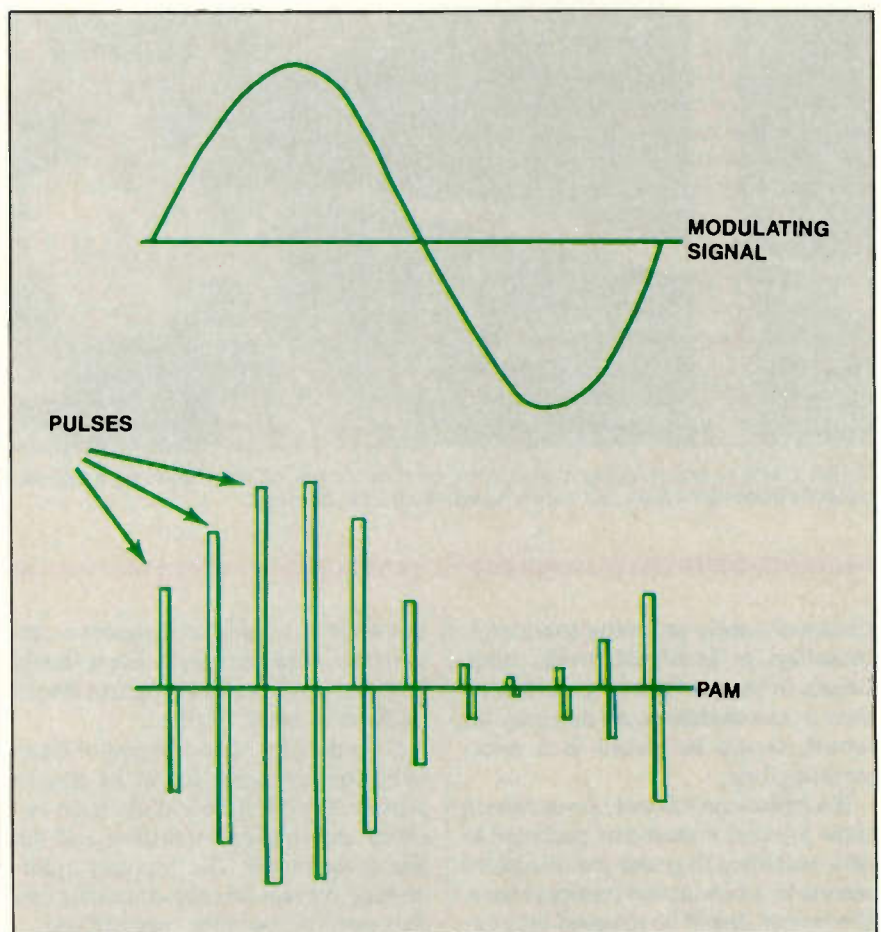

Figure 1. A sine wave can be converted to a pulse amplitude signal in a system called pulse amplitude modulation. As with other pulse-modulation systems, the pulsed version is more efficient than the original sinewave.

therefore, will recognize a noise spike or other noise signal as a pulsed signal.

Pulse-position modulation (PPM)

Figure 2 shows another way to convert an analog signal to pulses. Again, a sine wave is used to represent the analog signal, but any analog signal can be represented by these pulse methods.

As shown in Figure 2, the positions of the pulses are varied in accordance with various amplitudes. This system is very similar to phase modulation. Starting with a string of evenly spaced pulses, the modulation causes the pulses to occur earlier or later than the original pulses.

The system can also be thought of as

a frequency-modulated pulse. As with analog transmitters, there is only a fine shade of difference between phase and frequency modulation.

Any detector that works with phase modulation will also work with frequency modulation. (In fact, the so-called FM broadcast stations actually transmit a phase-modulated signal.)

Because a receiver in a pulse-position modulation system responds only to the phase (or frequency) of the pulses, it does not respond to noise signals. That, in some applications, makes it a better system for communicating information.

Unidentified pulse modulation

A pulsed radar system usually transmits evenly spaced pulses. The time it

Figure 2. Another way to convert an analog signal to pulses is with pulse-position modulation. In this system, the positions of the pulses are varied in accordance with various amplitudes. This system is similar to phase modulation. Starting with a string of evenly spaced pulses, the modulation causes the pulses to occur earlier or later than the original pulses.

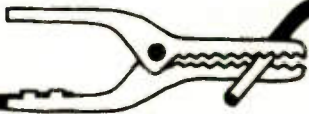
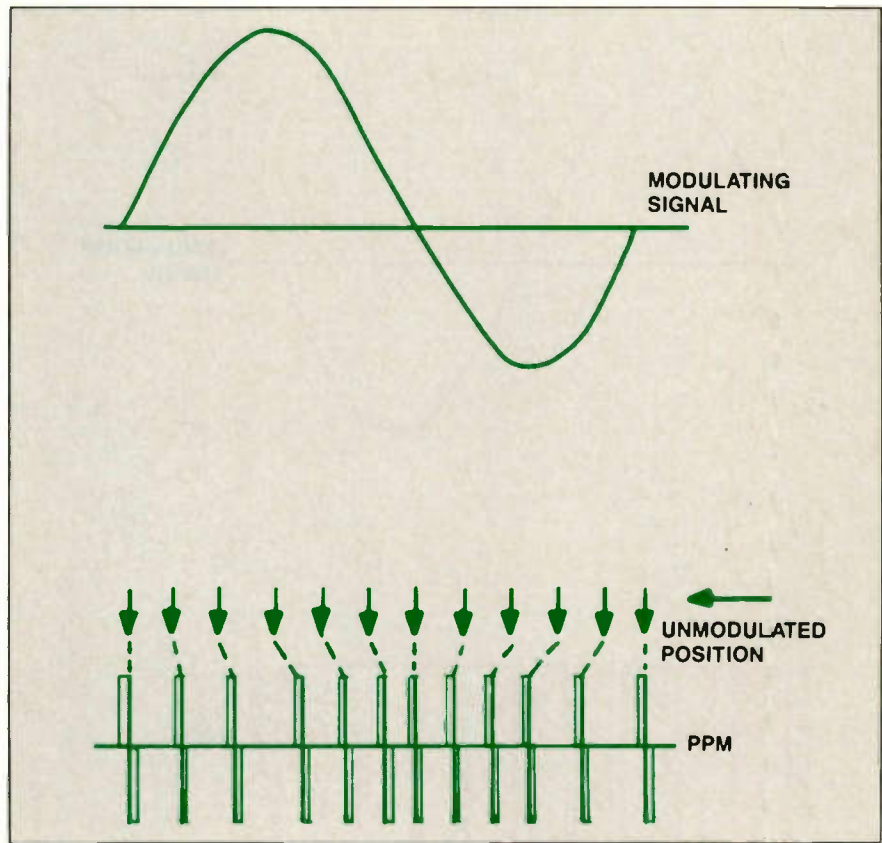

1988 National Professional Electronics Convention and Trade Show

August 1-6
Pheasant Run Resort
St. Charles, IL (Chicago area)

Increase your "current" business with:

Business Management Seminars	Technical Training in: Digital VCR
Dealer/Manufacturer Meetings	Compact Discs
Exhibits	Personal Computers
Social Events	Digital-Audio Tapes
	Super VHS/S-Camcorders

For information and registration, contact:

NPEC '88

2708 W. Berry St., Ft. Worth, TX 76109
817-921-9061



**You'll have nothing but sweet dreams
when you order from MCM Electronics!**

If you've been losing sleep because you can't get the electronic parts and components you need — when you need them — you haven't been dealing with MCM Electronics! Our all-new, expanded Catalog contains nearly 11,000 items, including lots of new test equipment at competitive prices you'll really appreciate. And, virtually every item is in-stock and ready to be shipped within 24 hours! Order your FREE copy today and get set for the "sweet dreams" you really deserve!

For your FREE copy, call TOLL-FREE

1-800-543-4330

In Ohio, call 1-800-762-4315

In Alaska or Hawaii,
call 1-800-858-1849

**600
NEW ITEMS!**



MCM ELECTRONICS

858 E. CONGRESS PARK DR.
CENTERVILLE, OH 45459-4072

A PREMIER Company



SOURCE NO. ES-35

Circle (20) on Reply Card

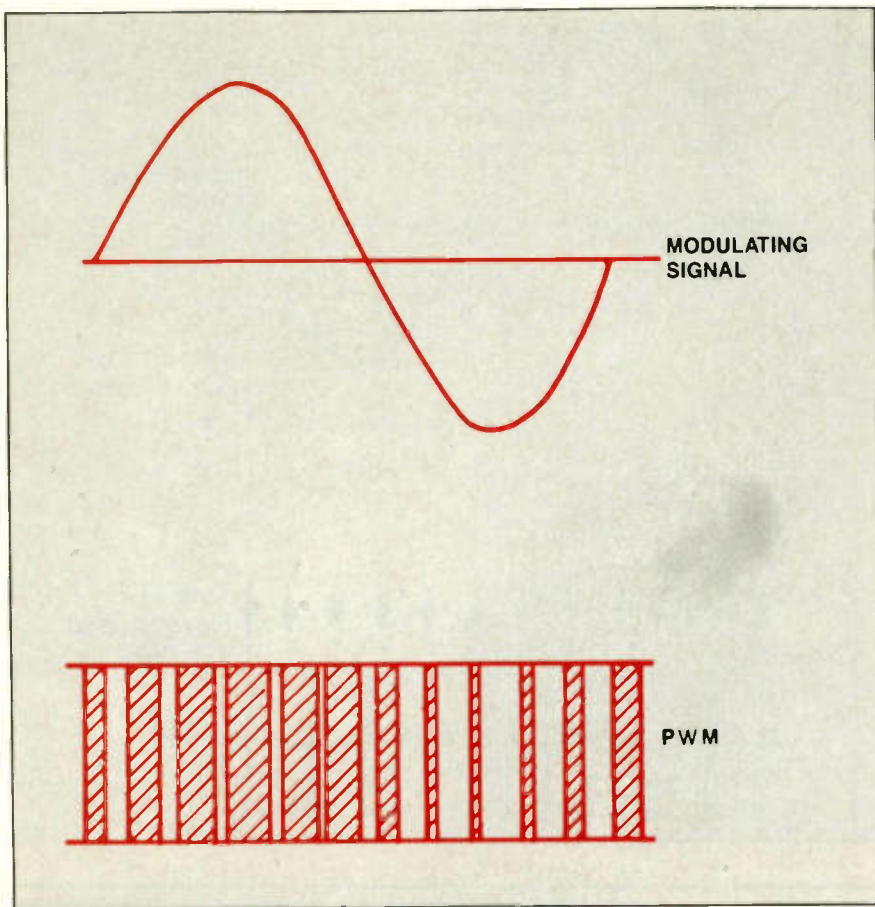

Figure 3. In pulse-width modulation (PWM), wider pulses represent higher amplitudes; narrower pulses represent lower amplitudes. The average value of the pulses can easily be detected by a simple diode detector or by an integrating circuit. Technicians are likely to run across this type of modulation because switching regulators use it to control output power.

takes for those pulses to travel to a target and return is measured. Half of that time is the time it takes for the pulse to go to the target. That time is used to determine the target distance.

$$\text{round trip distance} = \text{rate} \times \text{time}$$

$$\text{one-way distance (miles to target)} = (\text{rate}/2) \times \text{time}$$

The rate is equal to 186,000 miles per second, the speed of light, which is the speed of propagation of any electromagnetic radiation, such as a radar signal.

One very exciting field of electronics that is important to the military is called ECM (electronic countermeasures). Among other things, ECM involves messing up the enemy's electronic signals. A simple example is jamming, which involves overriding the enemy's signal with noise or some other type of transmission. When I was younger, I had the fun of working on radar and ECM equipment.

The ECM technical people found a

"perfect" way to confuse a radar system. They simply inserted one of their own pulses between every radar pulse. That meant there were twice as many pulses received as there were sent. Because the time between pulses was cut in half, it looked like the target was only half the distance away. That, in turn, caused the automatic gun-laying and other equipment to go crazy.

The radar people have their own pride of geniuses. They got around the clever ECM trick by frequency-modulating each pulse. That way, the receiving equipment could be designed to recognize only the pulses that the transmitter actually sent.

Pulse width modulation

Technicians working on state-of-the-art equipment are likely to run across pulse width modulation (PWM). Figure 3 shows the principle. Wider pulses represent higher amplitudes; narrower pulses represent lower amplitudes. The average value of the pulses can easily be detected by a simple diode detector or

by an integrating circuit.

Technicians are likely to run across this type of modulation because switching regulators use it to control output power. In the next issue, I'll review switching regulators and other types of regulators.

Measuring rms values

Remember that rms voltage (V) is equal to rms current (I) multiplied by resistance. By tradition, rms voltage and rms current are represented by capital letters without subscripts (V and I).

I have a reason for this very fundamental review. In this article, I am going to show some methods of measuring rms values of voltage and current. If the rms voltage is known, the rms current can be determined; if the rms current is known, the rms voltage is easily determined. This assures that the circuit resistance or impedance is known.

AC meters such as VOMs and voltohmmeters are calibrated to measure the rms value of *only* a pure sine wave. If the waveform of voltage being measured is not sinusoidal, you cannot use an ordinary ac voltmeter to directly measure its rms value.

Meters are available that will directly measure rms values. They haven't yet gained a lot of popularity because peak-to-peak values of non-sinusoidal values are usually given on schematics. Those values are easily measured with an oscilloscope.

Indirect methods of measuring rms values will be given in this article. The most important reason for knowing how those methods work is that they show exactly what rms value means.

Using a light meter

This method of measuring non-sinusoidal voltages is useful because it explains why rms is sometimes referred to as the *heating effect* or effective value. The measurement setup is shown in Figure 4.

Remember that the amount of light you get from a filament lamp depends directly upon the temperature of the filament. For this method, an unknown, non-sinusoidal voltage is first delivered to a small lamp. A light meter is positioned where its indicator deflects to some value that's easy to identify. The variable dc supply is then switched into the circuit to replace the unknown sinusoid, and the voltage is adjusted to get exactly the same light-meter deflection as before. The value of the dc voltage

required to achieve the same light meter deflection is equal to the rms value of the unknown voltage.

The measurement just described works best in a darkened room. Repeat the procedure several times using different points on the upper half of the light meter scale. If the unknown voltage or current is too high, a voltage divider (or rheostat) can be used to lower it to a workable value. If it is too low, use the scope method described next.

You can easily verify the method illustrated in Figure 4. Apply a pure sine wave of known voltage to the lamp in place of the unknown input. A good value to use is $6.3V_{rms}$ from a filament transformer to a lamp rated at 6.3V. Set up the light meter, then switch to the dc source. You will find that a dc voltage of 6.3V is needed to get the same light-meter deflection. Therefore, an rms value of voltage is equal to the dc voltage required to achieve the same effect.

Using an oscilloscope display

This method can be used for measuring rms voltage or current. Keep in

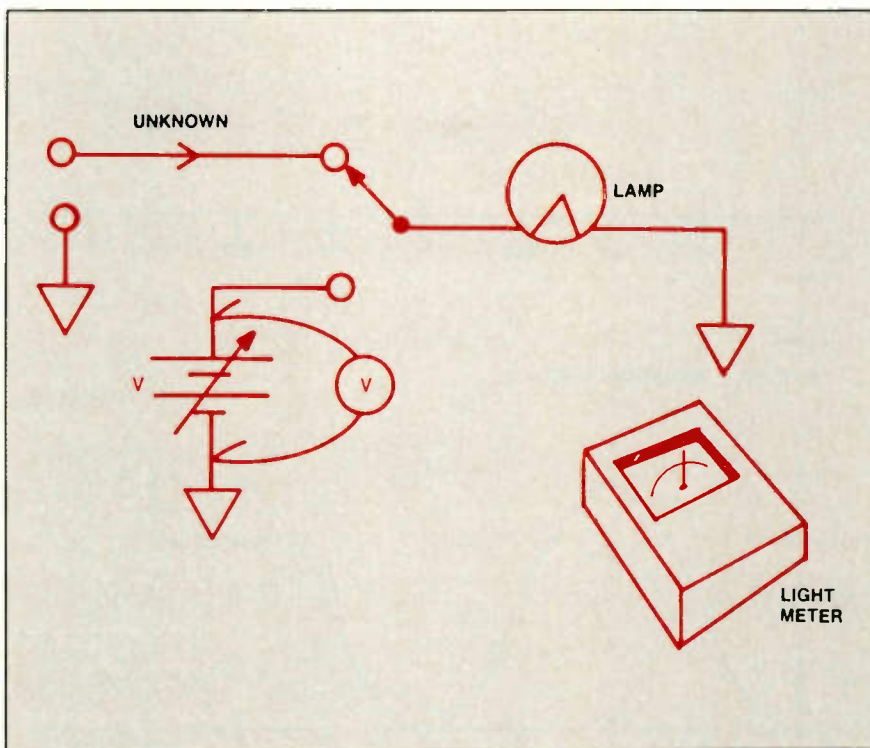

Figure 4. The rms or *effective* value of an ac voltage is equivalent to the value of the dc voltage that will provide the same heating effect. The rms value can be determined by using a light meter.

TOOL KIT SOLUTIONS!



From Tool Kit Specialists, Inc.

TKS Features:

- Tool kits for the field service professional
- Custom tool kits
- Wide range of tools, cases and test equipment
- TKS expertise and service

Call for information (408) 745-6020
800-621-0854 Ext. 202

TOOL KIT SPECIALISTS, INC.
1366 Borregas Avenue
Sunnyvale, CA 94089



Circle (21) on Reply Card

Presenting an affordable Light Box System.

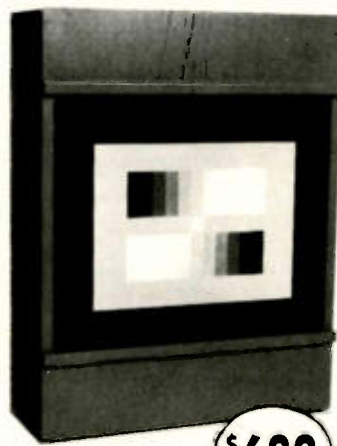

\$688

The method most
manufacturers recommend

Model TR100 CB
Camera Light Box
with (2) transparencies

- (2) 3200° Kelvin Lamps (meets mfr. spec.)
- 1-year conditional guarantee
- Transparencies mounted in acrylic with optical scratch-resistant surface
- 11-step gray scale transparency
- 7-Bar color transparency
- All orders are shipped within 72 hours, U.P.S.

NUTRONIX (313) 939-2740



P.O. Box 77103 • Sterling Hts., MI 48077



Circle (22) on Reply Card

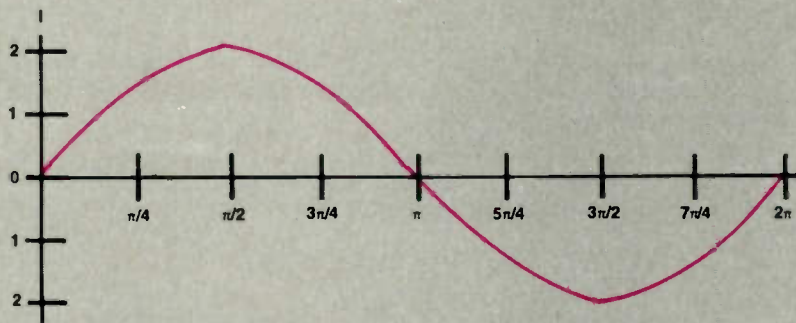

FIGURE 5A SINUSOIDAL CURRENT

STEP 1: START WITH THE SINE WAVE.

$$I = I_{MAX} \times \sin \theta$$

IN THIS CASE:

$$I = 2 \sin \theta$$

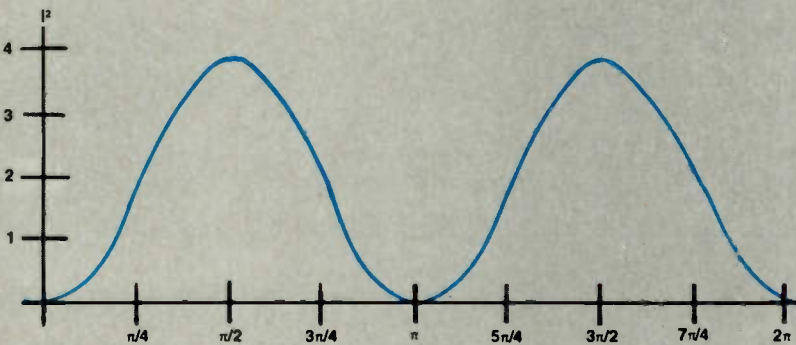

FIGURE 5B SINUSOIDAL CURRENT SQUARED

STEP 2: SQUARE THE VALUES OF THE SINE WAVE

$$I^2 = I_{MAX}^2 \times \sin^2 \theta$$

$$= 4 \sin^2 \theta$$

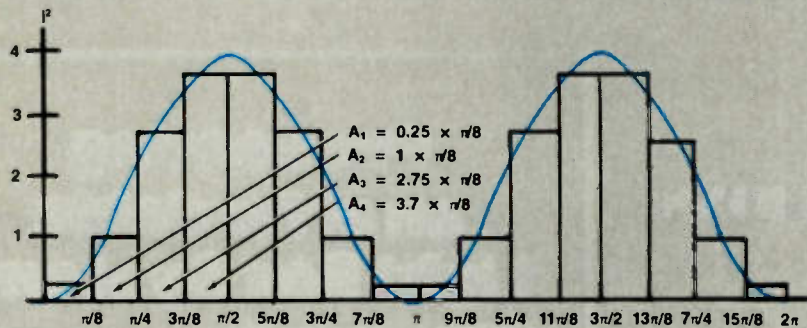

FIGURE 5C SINUSOIDAL CURRENT SQUARED

STEP 3: APPROXIMATE THE AREA UNDER THE SIN² CURVE BY DIVIDING IT INTO RECTANGLES. DIVIDE THE AREA BY THE LENGTH OF THE BASE.

NOTE: THERE ARE FOUR OF EACH SIZE OF RECTANGLE, SO THE TOTAL AREA IS:

$$A_T = 4(A_1 + A_2 + A_3 + A_4)$$

$$= 4(0.25 \times \pi/8 + 1 \times \pi/8 + 2.75 \times \pi/8 + 3.7 \times \pi/8)$$

$$= 4\pi/8(0.25 + 1 + 2.75 + 3.7)$$

$$= \pi/2(7.7)$$

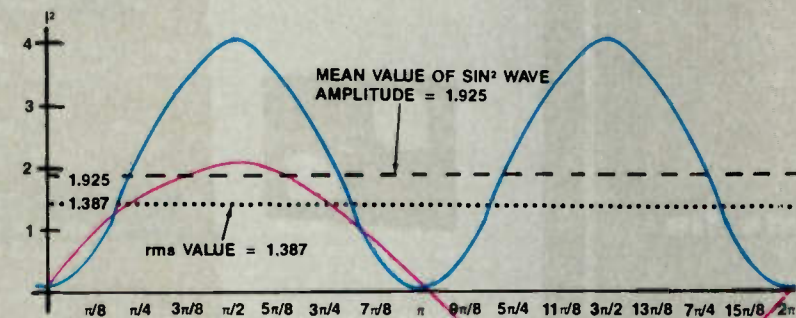

FIGURE 5D

STEP 4: TAKE THE SQUARE ROOT OF THE MEAN VALUE OF THE SIN² WAVE.

$$MEAN = A_T / PERIOD = \pi/2(7.7) \div 2\pi = 7.7/4 = 1.925$$

$$\sqrt{MEAN} = \sqrt{1.925} = 1.387$$

$$RATIO \text{ OF MEAN TO PEAK:}$$

$$R = 1.387/2 = 0.694$$

NOTE: THE APPROXIMATE rms VALUE = 0.694 OF PEAK. THIS IS ONLY A 1.8% ERROR FROM THE ACTUAL RATIO OF 0.707.

Figure 5. The rms value of a sinusoidal ac can be approximated graphically by finding the square of the sinewave, calculating the area under the square, dividing this area by the length of the period to find the mean value of the squared waveform, then taking the square root of this mean value to find the effective value of the original sinusoid. This is the root of the mean of the square, or rms. The rms value is calculated because the average value of a sinusoidal voltage is zero. In this case, the approximate calculated value of the ratio of the rms value to the peak value is 1.387 to 2, or 0.694. The exact value of this ratio is 0.707. The error is $(0.707-0.694)/0.707$, or about 1.8%. Not a bad approximation.

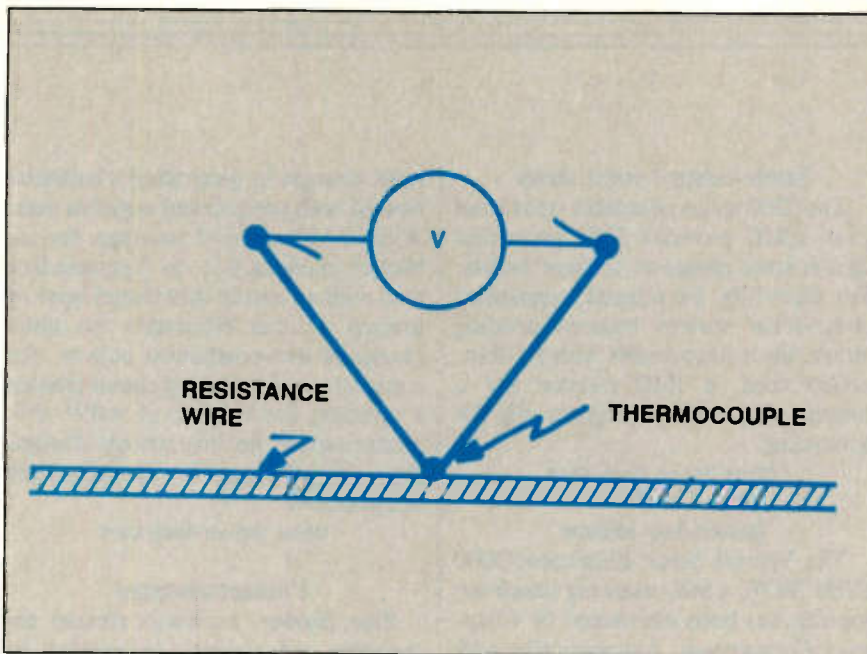

Figure 6. The thermocouple meter uses temperature to measure rms values. The current (or voltage converted to current) flows through a resistance wire. A thermocouple welded to that wire produces a voltage proportional to the temperature. The voltmeter measures the voltage produced. That voltmeter is calibrated to measure the rms (or heat-producing) value of the voltage or current being measured.

mind the fact that a current waveform can be observed on an oscilloscope. The trick is to pass the current through a 1Ω resistor. The voltage across that resistor is numerically equal to the current:

$$I = V/R = V/1 = V$$

That voltage can be displayed on the oscilloscope for the purpose of determining the rms current.

The letters *rms* are a sort of backward code for describing the method used to find the value. The procedure is given here:

1. Square the values.
2. Find the Mean (average).
3. Take the Root of the mean.

In reverse order: R-M-S.

Consider the one cycle of sine wave of Figure 5a. We would like to find its *effective* value. If we were to simply take the average value, we would end up with zero because half of the waveform is above the zero level and half is below the zero level.

In order to get around this problem, we can *square* the waveform, which makes the whole thing positive (the square of a negative number is positive), then find the average value of this squared function, then take the square

root of this average. This method will give us the effective value we were looking for. (See Figure 5b.)

The branch of mathematics called calculus provides mathematicians with a way to calculate the rms value exactly by, in effect, dividing the squared waveform into an infinite number of vanishingly thin sections, calculating the area of each section, adding up all the values and dividing by the period (in this case 360° , or 2π). This method calculates the area under the squared waveform, then divides that area by the length of its base. The result will be the *effective* height of the squared waveform. Taking the square root gives us the effective height of the waveform we started with or its effective value.

We can approximate this procedure without calculus by slightly altering the procedure. Choose a number of evenly spaced points on the original waveform and calculate the square of the amplitude. Use a table of these squared values to draw the waveform of the squared function. Note that because you squared these values, the squared function is positive everywhere. This is the first step of the rms process.

Divide the squared waveform into vertical sections of equal thicknesses (see Figure 5c). The more sections you use and the more carefully you draw them,

the better your approximation will be. Then multiply the height and width of each section to find the area of the sections.

Add up all the areas you found this way. This figure is the area under the squared waveform. Now, if you divide the total area by the total width of all of the sections, which is the period of the waveform, you will find a number that is the *effective* amplitude of the squared waveform (step 2 of the rms process). This number is also called the *mean* value of the squared waveform. (See Figure 5d.)

Now take the square root of the mean value (step 3 of the rms process) to find the rms value of the original sine wave.

If you follow this procedure carefully, you will find that the rms value of the sine wave is approximately seven-tenths of the peak value. The greater the number of divisions you make and the more carefully you draw them, the closer you will come to the seven-tenths value. If you calculate it exactly, it will be exactly 0.707 times the peak value.

The same procedure—called the graphical solution of determining rms values—can be used to find the rms value of an oscilloscope voltage display. The waveform must repeat over and over for this to be a legitimate measurement of rms voltage or current.

Thermionic method

In the early days of radio, broadcast stations used a *caloric* method of measuring their output power. I don't see equipment for this method being advertised any more, so I assume it is no longer being used.

The procedure was simple: A dummy load was immersed in a tank of distilled water, the transmitter was energized, and the resulting increase in water temperature was noted. A chart was used to convert the temperature rise to power.

The thermocouple meter is another method of using temperature as a method of measuring rms values. Figure 6 shows how it works. The current (or voltage converted to current) flows through a resistance wire. A thermocouple welded to that wire produces a voltage proportional to the temperature. The voltmeter measures the voltage produced. That voltmeter is calibrated to measure the rms (or heat-producing) value of the voltage or current being measured.

ES&T

Volt-ohm-ammeter

A.W. Sperry Instruments has announced its redesigned model SPR-311 PLUS rotary scale, snap-around volt-ohm-ammeter. The unit tests fractional horsepower and low-current equipment from 1.5A to 150A and reads to 600V and 25 Ω mid-scale. The fuse and battery have been enclosed within the meter, the ohmprobe has been eliminated, and a separate range has been added to the dial drum for ohms and continuity measurement.

Circle (74) on Reply Card

Dissipative mat material

Atrix has introduced a dissipative mat material for ESD workstations. The rubber-based material is tear and snag resistant and is impervious to most solvents, hot solder and hot solder fluxes. Two thicknesses are available: 0.030-inch (for use as a foldable field service mat) and 0.100-inch (for permanent work stations).

Circle (75) on Reply Card

Logic comparison tester

A logic comparator, the AR-90LMC, has been introduced by *American Reliance*. It features two modes of comparison, normal or latch, and has a built-in monitor mode for viewing logic states. The unit, which can be used with both TTL and CMOS logic, operates at 20MHz and can detect a single timing error as short as 50ns. It tests ICs of up to 28 pins and includes both 16- and 28-pin test clips.

Circle (76) on Reply Card

Soldering systems

Two UL-listed soldering systems are available from *Ungar*, a division of Eldon Industries. Both units offer variable, closed-loop temperature control over a range of 400°F to 800°F. The CMOS-safe systems can be calibrated at the station without disassembly and are fully grounded from tip to plug. Temperature stability at idle is less than $\pm 10^\circ\text{F}$. Tip potential is less than 2mV rms, and tip-to-ground resistance is less than 2.0 Ω . The UTC-100 system is equipped with a macro iron for heavier ground planes; the UTC-200 unit has a micro iron for fine lead spacings.

Circle (77) on Reply Card

Static-control wrist strap

The 2200 series adjustable wrist strap from *HMC* provides 360° protection against static charge on workers' bodies. For durability, the tapered, segmented strain-relief system reduces bending stress. Each strap comes with a 5-foot, coiled cord, a 1M Ω resistor and a banana plug with an alligator clip for grounding.

Circle (78) on Reply Card

Bench-top ionizer

The Volume Static Eliminator 3000 (VSE 3000), a self-balancing bench-top ionizer, has been introduced by *Chapman Corporation*. Automatically self-balancing, the electrically powered (non-nuclear) ionizer neutralizes static charges by combining the balance of a nuclear ionizer with the fast decay rate available with electrical ionizers.

Circle (79) on Reply Card

Static-dissipative desoldering braid

Chemtronics' Chem-Wik SD desoldering braid is packaged on static-dissipative bobbins and protects



microcircuits from potentially damaging electrostatic discharge during the desoldering process. The finely woven, flat copper braid is impregnated with pure rosin flux and comes on 5- and 10-foot spools in widths from 0.025 inches to 0.190 inches.

Circle (80) on Reply Card

Ionized-air blower

Contact East has introduced a non-nuclear, ionized-air blower that removes

static charges by generating a balanced flow of both positive and negative ions. With its 60° angle of coverage, the air blower blankets a 2- to 5-square-foot area with an evenly distributed layer of ionized air that eliminates the static charge of non-conductive objects. An automatic, self-balancing circuit ensures a constant ion balance of +0V/-5V, compensating for line voltage fluctuations or changes in humidity and temperature.

Circle (81) on Reply Card

Contact cleaners

Blue Shower, a contact cleaner for sensitive components introduced by *Tech Spray*, consists of a proprietary blend of inert fluorocarbon solvents that act as an azeotrope. The cleaner, which wets, penetrates and leaves no residue, is active on ionic (polar, inorganic), non-ionic (non-polar, organic) and articulate contaminants. Also available is the FD Electronic Cleaner, which features 100% freon TF, leaves no residue and may be used during equipment operation. This product is safe for plastics and insulation materials.

Circle (82) on Reply Card

Rework station

Nu-Concept Systems has introduced the SMKIT, which includes all accessories needed to begin surface-mount prototype and rework. The kit includes a solder paste dispenser with a vacuum pick-up and placement probe, a hot-air repair terminal with all surface-mount accessories (used to reflow solder when applying or removing components), and a tweezer-type hand tool (with a transformer-operated safety control station) that can accommodate SMDs as well as DIP components.

Circle (83) on Reply Card

Breadboard, logic probe

Global Specialties offers a way to prototype or experiment with IBM PC-compatible interfaces. With a buffered plug-in card and 60-conductor cable that connects to any IBM compatible PC, the PB-88/4 brings all PC bus signals to labeled, solderless sockets and provides more than 3,300 breadboard contact points. Power is supplied by the host computer.

Also offered is the LP-5 logic probe, which is capable of capturing pulses as short as 5ns and pulse trains as fast as 100MHz. The probe incorporates both pulse and memory modes, switch-selectable TTL/CMOS thresholds, and three different color LEDs.

Circle (84) on Reply Card

Window test kit

The *Antenna Specialists* has introduced the model KAV 850 window test kit, which permits a quick pre-evaluation of auto window glass for properties that might impair performance of glass-mounted mobile communications antennas. The test kit deter-



mines whether hidden metallic tinting films, owner-applied tinting kits or instant defrost options could substantially affect antenna performance. The tester is used with a digital capacitance meter capable of 1pF measurement with 0.1pF resolution.

Circle (85) on Reply Card

Resistance decade box

The model 63 precision resistance decade box by *Brunelle* allows the user to select any resistor value from 1Ω to 9,999Ω in one step. It is appropriate for use in electrical measurements, as a substitution resistor and for experimentation. The device has wire-wound resistor elements, a low zero resistance and low inductance.

Circle (86) on Reply Card

Digital oscilloscope

Gage Applied Sciences has introduced CompuScope 220, a single-slot, PCB-

hardware and MS DOS-compatible software product that allows PCs to provide digitizing oscilloscope functions. It enables users to store and print data, as well as send and receive samples on data networks. Key features include a 40MS/s maximum sampling rate and up to 256K memory depth.

Circle (87) on Reply Card

Modular phone-line testers

Modular phone-line testers, available from *Jensen Tools*, are designed for use in 2- or 3-pair modular telephone jacks and network interfaces to pinpoint telephone wiring problems. An LED indicates whether the polarity is reversed. Each set contains a simple diode for tool insertion and two diodes with special applications for locations with limited accessibility.

Circle (88) on Reply Card

PC-based spectrum analyzer/scope

Rapid Systems has introduced the R350 turnkey, 2-channel spectrum analyzer and digital oscilloscope. It contains two 1MHz, 12-bit A/D converters, each with 32Kbyte (12 bits) data storage buffer and digital signal processor for real-time, 1024-point FFT spectrum display. This combination oscilloscope/spectrum analyzer offers 12-bit resolution, differential inputs, anti-aliasing filters on each channel, selectable gain and sample rate, spectrum averaging from 1 to 64 spectra, and a 500kHz bandwidth.

Circle (89) on Reply Card

Video training program

"Soldering: Tools and Techniques" is a live-action video training program introduced by *Industrial Training*. Topics include the selection and use of proper tools and materials, soldering iron maintenance, correct soldering procedures, troubleshooting soldered connections and desoldering. Lesson plans and testing materials are included.

Circle (90) on Reply Card

Surge suppressor product line

Sola has introduced a series of surge suppression devices designed to clamp power-line transients in less than 5ns for common-mode and less than 1ns for normal-mode. All seven models feature

CONSOLIDATED ELECTRONICS

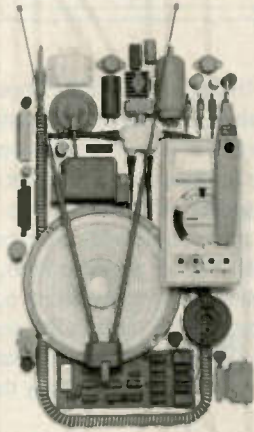

CONSUMER & INDUSTRIAL ELECTRONICS CATALOG • 17TH EDITION

THE ULTIMATE ELECTRONICS CATALOG.

Order your 260 page catalogue packed with over 10,000 money saving electronic parts and equipment. Send \$3.00 check or money order, or call 1-800-543-3568 today and use your Mastercard or Visa.
Consolidated Electronics, Incorporated
705 Watervliet Ave., Dayton, Ohio 45420-2599

NAME

ADDRESS

CITY

STATE

ZIP

Circle (23) on Reply Card

ATTENTION TECHNICIANS

- ★ JOB OPENINGS
- ★ MONTHLY TECHNICAL TRAINING PROGRAM
- ★ BUSINESS MANAGEMENT TRAINING
- ★ LOW COST INSURANCE
- ★ CERTIFICATION
- ★ TECHNICAL SEMINARS

All of this in a nonprofit International association for technicians

FIND OUT MORE:



604 N. Jackson St.
Greencastle, IN 46135

UL-listing and EMI/RFI noise rejection capabilities. Three different styles are offered: a power control center, plug strip models with six outlets, and plug-in models with two outlets. The latter two are offered with three performance levels. For all seven models, maximum transient current is rated at 6,500A. Peak wattage is 2.5 million for normal-mode and 170,000 for common-mode.

Circle (91) on Reply Card

Hand-held DMM

The models 487 and 488 hand-held DMMs from *Simpson* feature autoranging, a 71-segment LCD bar graph and a 3¼-digit LCD display. Both feature 20kHz frequency response and overload protection. The 488 reads true rms up to 750Vac and 10.0A. Other features include resistance ranges to 30MΩ, an audible diode/continuity test indicator and data and peak holds for all functions and ranges.

Circle (92) on Reply Card

Pick-and-place system

O.K. Industries has introduced the SMT-875, a manual pick-and-place system for surface-mount devices. The

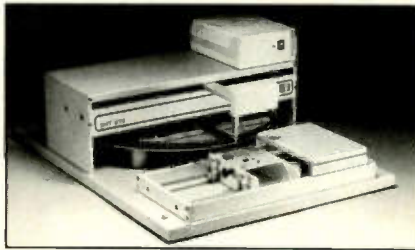

system features an anti-static carousel, a floating X-Y vacuum pick-up head and a board holder. The operator selects a component, picks it with the vacuum head, then guides it to the appropriate position on the board, where it's released on contact.

Circle (93) on Reply Card

Digital test systems

The 90 Series digital testers for stand-alone troubleshooting of microproces-

sor-based products and systems has been introduced by *John Fluke Manufacturing*. The self-contained testing device clips onto the processor (even soldered-in microprocessors) in the unit under test. The unit "cycle steals" and overdrives the control and bus lines to exercise and test the circuitry while allowing the unit under test to operate normally. There are 16 pre-programmed bus, memory, I/O and probe tests. An RS-232 interface allows remote operation.

Circle (94) on Reply Card

Conductive top

A conductive top with a flush-mount grounding system from *Workplace Systems* allows the repair of ESD-sensitive electronics components without a grounding bolt on the work surface. Two banana plugs set flush into the front edge provide a convenient location to connect wrist straps.

Circle (95) on Reply Card

SPECIAL REPORT
SPECIAL REPORT
SPECIAL REPORT
SPECIAL REPORT
SPECIAL REPORT
SPECIAL REPORT
SPECIAL REPORT
SPECIAL REPORT
SPECIAL REPORT
SPECIAL REPORT
SPECIAL REPORT
SPECIAL REPORT
SPECIAL REPORT
SPECIAL REPORT
SPECIAL REPORT

TECHNICAL TRAINING

All you need to know
about the latest in
technical training and
literature is in this
exclusive report
coming in August in:

ELECTRONIC
Servicing & Technology

Soldering iron

M. M. Newman has introduced a soldering iron and a soldering-iron stand.

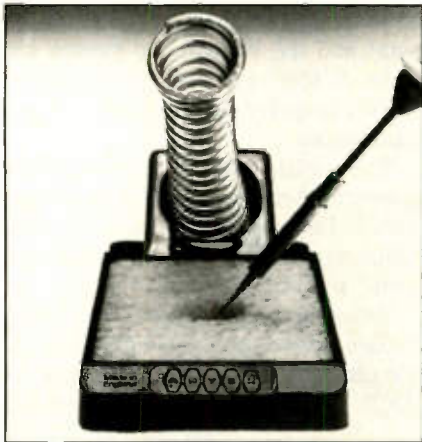

The Antex ST-4 soldering iron stand features a coil spring holder, a 1/2-inch sponge for tip wiping and a center hole for collecting excess dross. The unit is designed for use with all miniature soldering irons.

The Antex model G/3U miniature soldering iron heats up to 725° in 45 seconds and weighs 3/4 of an ounce. Tips come in 40 styles and sizes from 0.012- to 3/16-inch diameter.

Circle (96) on Reply Card

Micro probes

Minitool has introduced a line of micro probes for manual electrical testing of small circuits. Interchangeable probe handles are supplied with flexible, color-coded lead wire and a standard banana plug. The interchangeable 0.5mm-diameter steel or tungsten probe tips are available in straight and bent configurations. Probes are also available with an audible beeper.

Circle (97) on Reply Card

Rechargeable soldering gun

The 1200 portable, rechargeable soldering gun from Ungar operates on Ni-Cd batteries and solders 250 joints between charges. The UL-listed gun pro-

vides overnight recharging, a safety lock to prevent accidental turn-on, and a trigger-activated light to illuminate the work piece. Although the gun is equipped with a general-purpose soldering tip, a fine tip and a 60W, heavy-duty tip are also available.

Circle (98) on Reply Card

UHF spectrum analyzer

Panntek Instruments has announced its SA-500E 550MHz spectrum analyzer. This unit provides frequency-domain signal viewing with an on-screen dynamic range of 70dB when connected to an X-Y display or oscilloscope. The display center frequency is adjustable from 1MHz to 550MHz. A 70dB, front-panel RF-input step-attenuator is included along with crystal-controlled frequency markers at 5MHz and 50MHz intervals.

Circle (99) on Reply Card

ES&T

New ESD Mat

New dissipative Atrix ESD material allows users to make custom foldable field service workstations. Snag-resistant material is .030-in. thick, resists solvents, fluxes, solder, and does not require edge binding. Dissipative value is 10⁶ to 10⁸.

May be ordered plain or pocketed. Includes snap fastener and adaptors for static protection. Also available in .100-in. thickness for permanent workstations.

Atrix also manufactures a complete line of rugged circuit transport cases that are double-walled and double-latched, with dissipative foam liners and tie-down straps.

Call the Atrix Easy-Order toll-free number for more information.

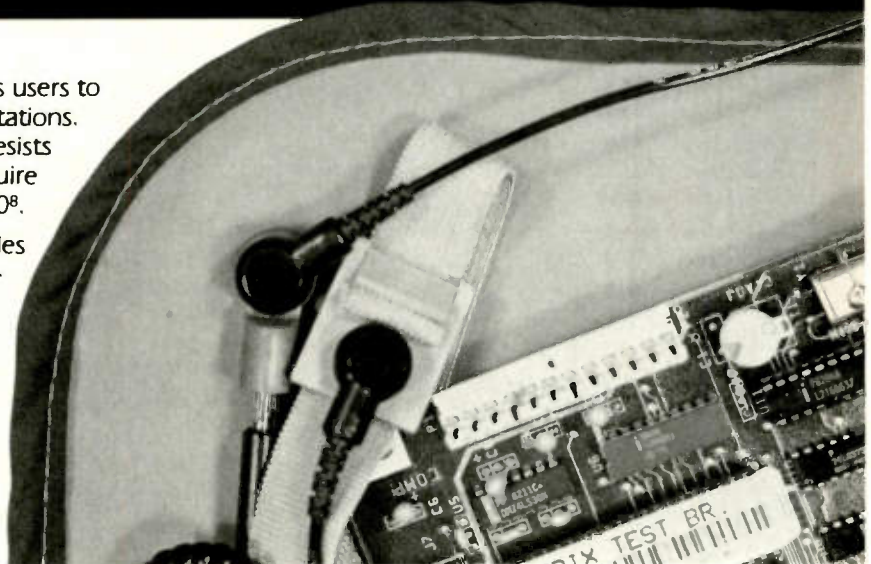

 **ATRIX, INC** 14301 Ewing Avenue South Burnsville, MN 55337

(612) 894-6154 1-800-222-6154 FAX (612) 894-6256 Telex 9102400139

Circle (24) on Reply Card

Troubleshooting tips

Dead Set Sharp 19J65 (Photofact 2304-1)

Because this chassis and the similar "H" chassis have a history of flyback problems, I checked the flyback first. High-voltage putty had been applied to it, which implied that someone had previously tried to correct an arcing problem. I then replaced the flyback and turned on the set. Still dead.

My next step was to check the voltages at the regulator, SCR701. The anode voltage was 158V, the specified voltage, but voltages at the gate and cathode were about 70V. In many cases, when a dead-set condition occurs on this set, SCR701 and the regulator chip, IC701, are faulty. I replaced them with Sharp exact replacements, because some experts advise against using generic substitutes for these components. The set remained inoperative.

I next injected horizontal drive at the base of the horizontal drive transistor, Q601. This caused the set to operate but without vertical sweep. While I measured R427 for the 12.2V source (which was about 17V on the feed side of the resistor but only 1.5V on the output side), I noticed that the solder on the resistor pad was molten. A severe short on the 12.2V line evidently was causing R427 to overheat to the point of melting the solder at its pad.

A resistance check on this line showed only 6.5Ω to ground, when it should have been more than 400Ω. I then started a long procedure of desoldering, one at a time, all the points that are fed by the 12.2V source. I found several shorted components: D403, D404, D405, D406 and Q403. After I had replaced these parts, the resistance increased to approximately 100Ω. This resistance was still too low, and the set still wouldn't start.

I then decided to seek some assistance

from another tech, Steve Ashcraft. On the basis of the evidence I described to him, he concluded that IC801 might be the culprit. I had wondered about that earlier because IC801 is a common link to both the horizontal (no start symptom) and the vertical (no sweep) circuits. When I replaced IC801, the set started properly and exhibited full vertical sweep.

The repair still wasn't complete, however, because there was still no video. Steve checked and found that Q401 was shorted. Replacing that transistor restored the video.

Arcing from the flyback presumably caused severe problems in most of the circuitry that derived its power from the 12.2V source, a flyback-derived source.

Michael B. Danish
Mike's Repair Service
Aberdeen Proving Ground, MD
(With assistance from
Steven Ashcraft,
Steve's TV Service)

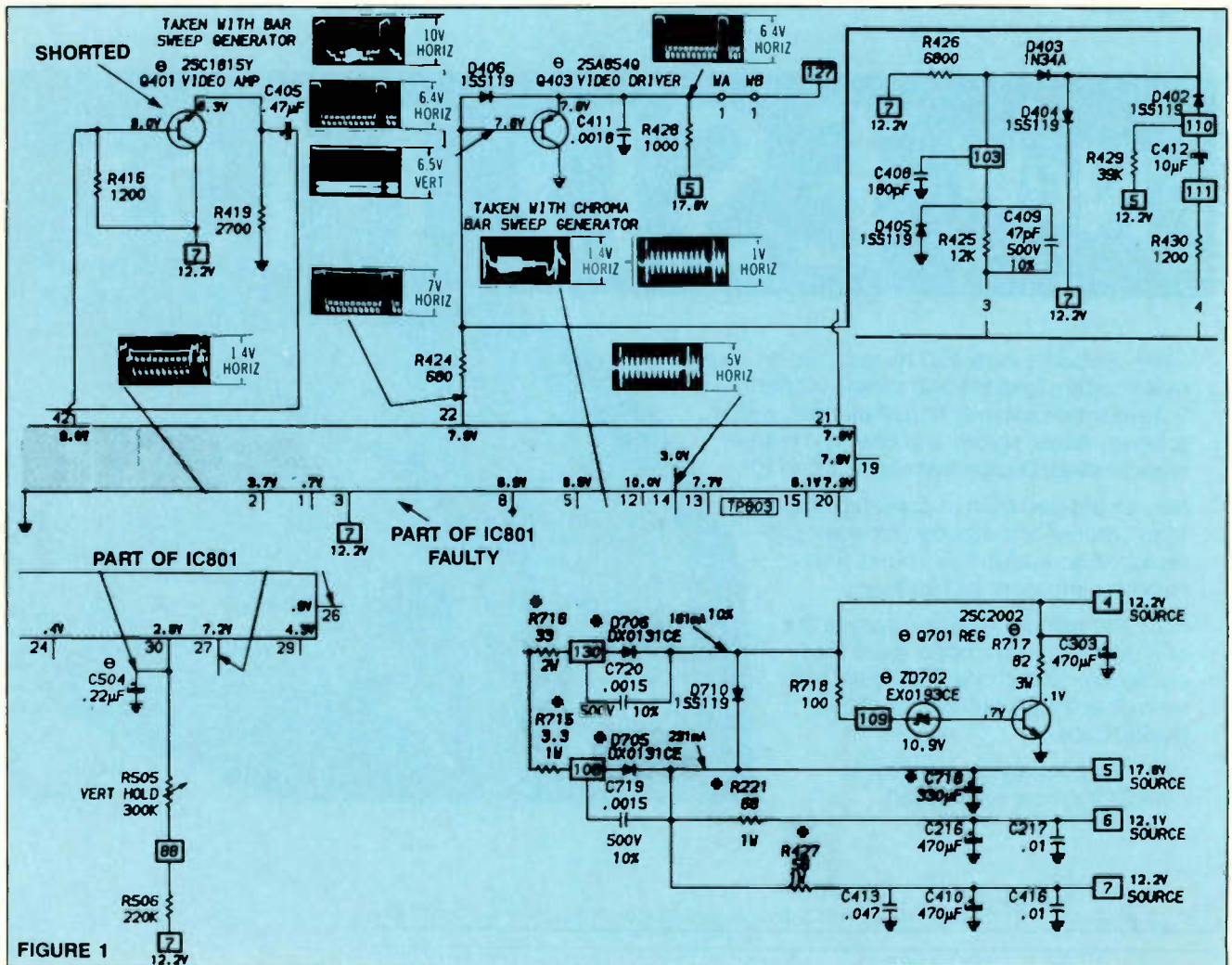

FIGURE 1

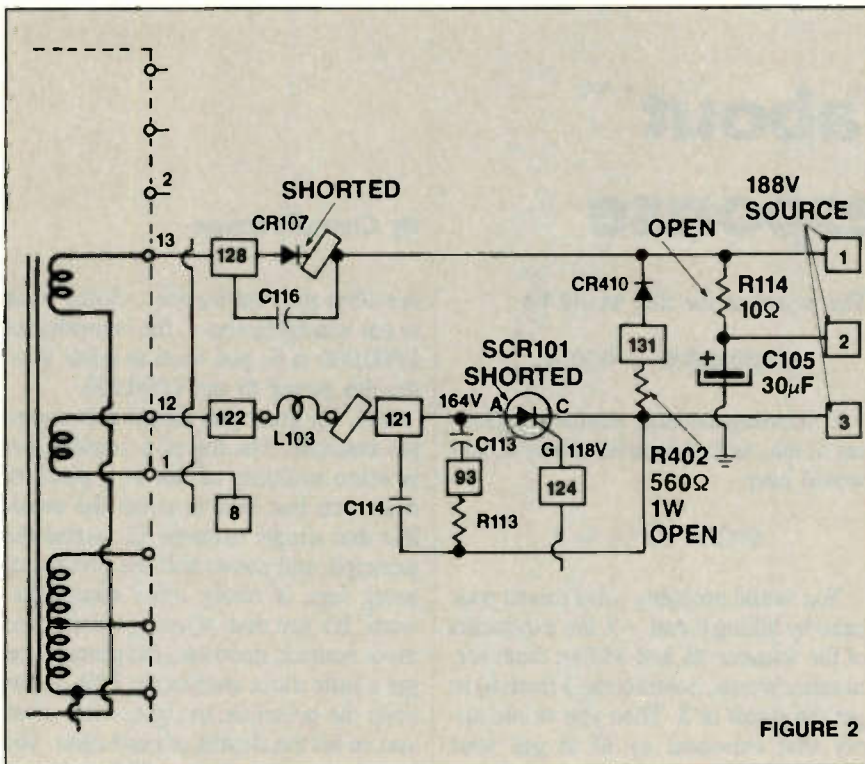

FIGURE 2

**Dead set (Makes slight ticking sound)
RCA CTC 120A
(Photofact 2217-1)**

When this set was brought to the shop, it appeared to be dead except that it made a slight ticking sound. I suspected a power-supply failure of some kind. Because this set derives most of its operating voltages from a scan and regulated source from the flyback, that's where I started making voltage tests.

The first problem I found was the absence of the 118V regulated source, originating at SCR 101, at point #3. This led me to check components in the scan and regulated supply. I found both SCR 101 (near pin 12 of the flyback) and CR 107 (connected to pin 13 of the flyback) to be shorted. R402, a 560Ω, 1W device connected to C of SCR 101, was open. I replaced these three defective components, and as a precautionary measure I replaced IC 401.

When I again applied power to the set, the high voltage, raster and audio had returned, but the picture was excessively bright and showed heavy retrace lines. Video was present but dim, and there was color.

I have found in the past that excessive brightness accompanied by retrace lines also can be caused by missing power-supply voltages, so I again began by

checking the scan-derived voltages. I found that the 188V source that supplies the control grid of the CRT was not present at point #2. This voltage is applied to the CRT via R114, so I immediately suspected that component. An ohmmeter check confirmed that R114 was open.

After R114 was replaced and power was applied, normal operation returned. After 16 hours of operation on the bench, the set was still operating normally, with supply voltages well within tolerance.

When I replaced U401, I soldered in a socket so that if this IC needed to be replaced in the future, desoldering and resoldering would not be necessary. I decided to check whether I had replaced this IC unnecessarily, so I put the original back into the circuit. The set played perfectly with the original IC back in the TV set.

This was one of those cases where if the IC had been defective, I would have saved time by replacing it automatically. In this case, however, it probably should have been left untouched until all other portions of the circuit had been checked and either replaced or confirmed to be good.

**Kenny L. Rutledge
Rutledge TV Service
Fayetteville, TN**

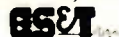

**INTRODUCTION TO VCR REPAIR
ON VHS VIDEO TAPE**

This new release by Ucando explains how the VCR works from the tuner to the RF modulator.

YOU WILL LEARN:

- How the chroma signal is processed
- How the luminance signal is processed
- How the audio signal is processed
- How the video drum servo works
- How the capstan servo works
- How the control head works
- How to clean the tape path
- Professional troubleshooting techniques

SAVE TIME AND MONEY

After viewing this program you will have a better understanding of how the VHS VCR functions. **To save time and money on your VCR repairs order your own VHS VCR tape now!** Simply call (513) 548-6113 and have your Master Card or Visa ready.

Price \$59.95

Please allow 2-4 weeks for delivery.

10 Day Money Back Guarantee!



**VCR EDUCATIONAL
PRODUCTS CO.**

P.O. BOX 386

GREENVILLE, OHIO 45331

Circle (25) on Reply Card

*Technicians,
Get Serious
About Your
Profession*



Being a certified electronics technician lets people know that you are a professional in your field. It tells them that you are serious about your work and can perform up to CET standards.

Now you can order the "Study Guide for the Associate-Level CET Test" from the International Society of Certified Electronics Technicians. It includes material covering the most often missed questions on the Associate CET exam. 8 1/2" x 11", paperback, 60 pages.

For More Information Contact:

ISCET, 2708 W. Berry, Fort Worth, TX 76109; (817) 921-9101

NAME _____

ADDRESS _____

CITY _____ STATE _____

ZIP _____

_____ copies @ \$5 (+ \$1 postage.)

_____ send material about ISCET and becoming certified.

Some basics about frequency response

By Conrad Persson

In the audio field, the most often cited amplifier specification is probably frequency response. You'll see such specs as " $\pm 0.5\text{dB}$ over the audio frequency range of 20Hz to 20kHz." Most of us have at least a vague idea of what that spec means, but it would probably be a worthwhile exercise to take another look at decibels and, *ugh*, logarithms.

I'm not sure why logarithms seem so difficult to deal with, but most of the people I know, including myself, get tangled up when looking at logarithms. However, logs are so essential to understanding electronics and every kind of natural phenomenon that you just can't ignore them.

Somehow the very word *logarithm* makes the idea seem more threatening. It's a strange sounding word and somehow suggests black magic, which is confirmed by the fact that, if you want to use logs, you have to consult a table of logarithms and use strange procedures such as interpolation to find the information you need. Kind of like astrology. Even worse, a logarithm consists of a *characteristic* and a *mantissa*, two more unfamiliar words.

One of the best ways to deal with a word that is unfamiliar and, therefore, is a roadblock to understanding is to look up its definition. According to the American Heritage Dictionary, the word logarithm is made up of two components and comes to us from the Greek: *logos* means reckoning, reasoning or ratio, and *arithmos* means number. So the word *logarithm* implies reckoning or reasoning about a number. That's not so bad.

An exercise with logs

Working with logs isn't really so tough either. Most techs probably do it every day without even knowing they're doing it. For example, take a $1\text{M}\Omega$ resistor, run a current of 1mA through it and determine the voltage across it.

The equation for this would be

$$1,000,000\Omega \times 0.001\text{A}$$

Converting the large numbers to powers of ten, as in scientific notation, you would have

$$10^6\Omega \times 10^{-3}\text{A} = ?$$

You would probably solve this in your head by taking 6 and -3 , the exponents of the number 10, and adding them (or, in other words, subtracting 3 from 6) to get the result of 3. Then you would apply that exponent to 10 to get your answer:

$$10^6\Omega \times 10^{-3} = 10^3 = 1,000$$

That's all there is to logarithms. Let's take a look at the definition of the term logarithm and see if that's what we did. Unfortunately, the definition of log is one of those things that starts out OK, but seems to wind up doubling back on itself and ending up confused. (In the interest of keeping it as simple as possible, we'll forget for the time being that it's possible to use bases other than 10.) For common logs (logs to the base 10), the logarithm of a number is the exponent to which you have to raise the num-

ber 10 to get that number. Going back to our examples above, the logarithm of 1,000,000 is 6; you have to raise 10 to the 6th power to get 1,000,000.

OK, I'll grant you that this is a simple example. The log of a number that is some multiple of ten is a piece of cake; you just have to count the zeros. But that simple example illustrates the principle and shows that the process of using logs is really quite straightforward. It's just that, when you use other, more realistic numbers, the process can get a little more confusing. Still, if you keep the principle in sight, even when you've hit the depths of confusion, you can always remind yourself that you understand the stuff and will eventually find your way out.

What's all this dB stuff?

Just for the fun of it, look up the log of the number 3 (or you can use a scientific calculator). According to the 4-place log tables in the book I have on my desk, the log of 3 is 0.4771. That makes a lot of sense if you think about it. The square root of 10, or $10^{0.5}$ ($10^{0.5}$), is 3.162. In other words, the log of 3.162 is 0.5. It makes sense, then, that the log of 3 (0.4771) would be somewhat less than the log of 3.162 (0.5). As we'll see just a little later, this particular loga-

Table 1.
Sound levels discernible by the human ear*

Decibels	Type of sound	Times as loud as 0dB
0	Barely discernible sound	0
10	Rustle of leaves	10
20	Whisper heard from 4 feet	100
40	Night noises in city	10,000
50	Average home	100,000
60	Conversation at 3 feet	1,000,000
80	Noisy city street	100,000,000
100	Blender	10,000,000,000
110	Jackhammer	100,000,000,000
120	Jet engine	1,000,000,000,000

*Adapted from a table published in the book "Understanding Sound" by Beulah Tanenbaum and Myra Stillman, published by McGraw-Hill Book Company, Copyright 1973.

Persson is editor of ES&T.

rithm proves to be very useful in electronics.

The scientific and engineering community, for a number of reasons, has chosen to represent power ratios logarithmically and have established the decibel (dB) as the unit of this measure. The formula for dB is

$$\text{dB} = 10 \times \log(P_2/P_1)$$

It has been determined that at a given sound volume (acoustic power), the power has to be increased by about 25% for the ear to detect an increase in volume. If you started with a volume of P_1 , then, and the volume was increased by 25%, the new volume (P_2) would be $P_1 + 0.25P_1$, or $1.25P_1$. Substituting this into the equation for dB yields

$$\begin{aligned} \text{dB} &= 10 \times \log(1.25P_1/P_1) \\ &= 10 \times \log(1.25) \\ &= 10 \times 0.0969 \\ &= 0.969\text{dB} \end{aligned}$$

Thus, the increase in sound volume that is just detectable by the human ear is very close to 1dB.

Another useful number

Let's take the case where P_2 is twice as large as P_1 :

$$\begin{aligned} \text{dB} &= 10 \times \log(2) \\ &= 10 \times 0.3010 \\ &= 3.01 \end{aligned}$$

That case provides another useful number. When the sound level increases by 3dB, the amount of power is twice as great. When the sound level decreases by 3dB, the sound level has become half of what it was.

These figures provide useful information for characterizing an audio amplifier. Some of today's best amplifiers provide amplification that barely varies across the audio frequency spectrum, a so-called "flat" frequency response.

But, armed with the information developed above, you can judge an audio amplifier's frequency response, which will be useful in servicing audio equipment.

For example, if you're working on an amplifier that seems lacking in high-frequency reproduction, you should look at the unit's ideal frequency response curve. If the curve is within about a decibel of flat across the frequency spectrum, the weak high-frequency represents a problem that needs to be corrected. If, on the other hand, the unit's frequency response curve shows a rolloff at the upper frequency end of the audio range, you would be wasting your time to try to do anything about it.

Audio specialists have established a range of sound levels discernible by the human ear, taking 0dB as the level of sound barely discernible by the ear. (See Table 1.)

ES&T

Learn how to repair VCRs...

Read

Video Corner

each month
in **ELECTRONIC**
Servicing & Technology



Plug in! To the NESDA system.

YOUR BUSINESS is in the world's fastest changing industry. If you're not careful, you could find your business in the dark.

But, you don't have to stay there.

Through a system of local, state, and regional groups, the National Electronics Sales & Service Dealers Assn. (NESDA) keeps members up-to-date with the fast pace of advancing technology while offering:

- ◆ Managerial and technical training.
- ◆ Business contacts.
- ◆ Technical and management certification.
- ◆ Information on new products.
- ◆ Legislative activities that affect the industry.

Don't be left in the dark. Let the NESDA system work FOR YOU!

For more information and an application, write to:
NESDA, 2708 W. Berry St., Ft. Worth, TX 76109; Ph (817) 921-9061

Name _____

Bus. Name _____

Address _____

State _____ Zip _____ Phone _____

Member of State Local Assn. _____

The 2 million-pixel CCD image sensor

The CCD (charge-coupled device) image sensor is a type of semiconductor that converts light into electrical signals. Each device is composed of arrays of tiny cells called *pixels* (picture elements). When light is focused through the lens onto the array, each pixel generates an electrical charge proportional to the intensity of the light. This electrical charge can be coded by additional circuits in order to reproduce the original image on a screen or on videotape.

Today, CCD image sensors are widely used as electronic eyes for various types of video cameras and camcorders. CCD image sensors have replaced conventional image pickup tubes because these sensors are smaller, lighter and more durable, and they consume much less power. This revolution occurred in much the same dramatic way in which semiconductors superseded vacuum tubes. CCD image sensors are also playing a growing role in applications such as robot vision systems and surveillance systems for nuclear power plants, as well as medical electronic equipment for seeing inside the body.

Picture elements and resolution

Today, CCD image sensors used in video cameras have approximately 400,000 pixels (maximum). A camera employing a 400,000-pixel CCD image sensor has very high resolution and can be used for the Super-VHS (S-VHS) format video system.

However, video cameras for high-definition TV or HDTV (the next-generation television system with high resolution) require CCD image sensors with as many as 2 million pixels. Because HDTV broadcasting is scheduled to start in 1990 in Japan, prototype HDTV cameras have been developed al-

Adapted from an article in the Toshiba Newsletter, March, 1988.

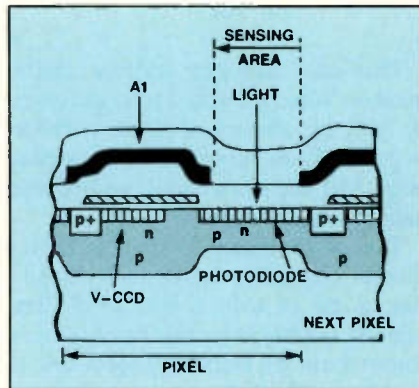

Figure 1. CCD image sensors are composed of arrays of pixels, which convert light into electrical signals. Conventional CCD image sensors have approximately 400,000 pixels. Although that pixel count gives a high enough resolution for the Super-VHS format video system, high-definition TV requires 2 million pixels.

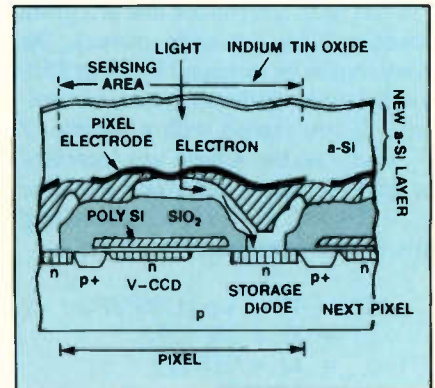

Figure 2. A 2 million-pixel CCD image sensor would usually have a decreased sensitivity or dynamic range because, if the pixel count is increased, the pixels would have to be smaller. Toshiba uses an additional layer of amorphous silicon to act as a sensing area and convert optical information to electric signals. The result is an aperture ratio of 100%.

ready by many manufacturers. These prototype cameras use pickup tubes, however, because 2 million-pixel CCD image sensors simply did not exist until now.

Creating a 2-million-pixel CCD image sensor

Toshiba researchers have recently succeeded in developing a 2-million-pixel CCD image sensor, which can be used for HDTV. The problem in producing CCD image sensors with such a large number of picture elements is the maintenance of characteristics like sensitivity and dynamic range (range of luminous intensity that can create images with acceptable contrast). That is, in proportion to the increase in the number of pixels, there is a reduction in the size of each pixel and the area that accepts light to be converted into electrical signals. This creates a problem of decreased sensitivity or dynamic range. It is impossible to produce a 2-million-pixel CCD image sensor with good

characteristics using the conventional method for fabricating CCD image sensors.

Solving the problem

One method of solving this problem was used by Toshiba. The company created a new method for designing CCD image sensors, overlaying a new, additional layer on a conventional CCD structure. This new layer is made of amorphous silicon (a-Si), which acts as a sensing area and also converts optical information to electrical signals. In this way, an aperture ratio (percentage of the sensing area that occupies the surface of each pixel) of 100% is achieved, increasing sensitivity to 210 nanoampere (nA) per lux, which is four to five times higher than that of conventional CCDs.

The company integrated 2 million pixels on a 16.2mm x 10.5mm chip by using a 1.0µm microlithographic technology, a design rule even finer than that used for a 1Mbit DRAM (dynamic random access memory).

ES&T

Quiz answers

Questions are on page 42.

1. C—decibels. Nepers are calculated by using logarithms with a base of epsilon (ϵ or e)—ln on your calculator. Nepers are more popular than decibels in some countries.
2. No. The base will be more positive than before, which will cut off the PNP transistor.
3. Control and audio. The tracks for these recorded signals are on the edge of the tape in one format.
4. In any system, a duplexer permits transmission and reception by the same antenna. The duplexer is located between the RF power output and the antenna.
5. $15\mu\text{s}$. Rise time is measured between the points where the voltage (or current) is 10% and 90% of full amplitude.
6. Using the approximation $\text{bandwidth} = 0.35/\text{rise time}$, and using $15\mu\text{s}$ for the rise time, the calculated bandwidth is slightly greater than 23kHz.
7. C—Locating the pre-amplifier as close as possible to the antenna gives the best signal-to-noise ratio. At other points, the signal and noise are both amplified.
8. A—equal to the supply voltage. The amplifier is cut off when there is no signal, so the collector voltage equals the supply voltage.
9. D—None of the choices given. You can make the spacing evenly divided by shaping the plates of the variable capacitor.
10. False. The oscillator frequency is usually higher than the RF frequency. However, if a radio has two bands, it is simpler to make the oscillator frequency higher than the signal frequency for one band and lower than the signal frequency for the other band.

Coming Up in

ELECTRONIC

Servicing & Technology

August

Technical Training/Literature

ES&T provides information on the kinds of courses and other training that is available to consumer electronic technicians. Including a listing of the schools, manufacturers and book companies that offer technical courses and materials.

Understanding Modern Circuits

ES&T discusses shutdown circuits in modern TVs: How they operate and how to diagnose them when there are problems.

Satellite TV Servicing

The ratio of gain to noise temperature is a very important specification of the TVRO system, as it helps you determine the quality of a system needed for a particular location. ES&T discusses this topic.

September

Multimeter Update

Here's an overview of some of the features on the newest crop of multimeters on the market. You'll find out what you can now do with meters that couldn't be done before.

Automotive Electronics Servicing

ES&T explores some of the new electronic circuits found in today's cars.

October

Preventive Maintenance Update

Some products, especially products like audiocassette recorders, VCRs, turntables and disc drives, should be periodically cleaned, lubricated and adjusted. ES&T tells you which of these consumer electronics products should be given preventive maintenance, and how to do it.

Servicing Mechanical Components

Many consumer electronics products have mechanical components. ES&T tells you what some of these mechanical components are, what can go wrong with them, and how to fix them when problems occur.

Plus ES&T's Regular Monthly Departments

Interfacing computers to the analog world—Part II

By Joseph J. Carr, CET

Editor's note: This is the second part in a continuing series on data conversion and the interfaces used to reconcile the language differences between digital computers and the analog world. This second installment will explain how the different types of analog-to-digital and digital-to-analog converters work.

As mentioned last month, data converters either convert a binary digital word to an equivalent current or voltage (digital-to-analog converters or DACs), or they convert an analog current or voltage to an equivalent binary word (analog-to-digital converters, or ADCs). To understand how they work, you should consider the DAC first. DACs are simpler than ADCs, and they are used in several types of ADCs.

Resistor ladder network circuits

The basis for DAC design is one of two simple resistor ladder network cir-

cuits. The *binary weighted ladder (BWL)* is shown in Figure 1. Figure 2 shows the *R-2R ladder*. Although the arithmetic for these circuits is extensive (and beyond the scope of this department), it is based nonetheless on simple Ohm's and Kirchhoff's law relationships.

The circuits in Figures 1 and 2 are equivalent circuits used to illustrate the principles involved. Each switch (S_1 - S_4) represents one binary input of the DAC. The switch represents 0 when set to the grounded position and 1 when set to the $+V_{ref}$ position.

In the BWL DAC in Figure 1, the output current, I_o , is the sum of $I_4 + I_3 + I_2 + I_1$. This equation is simply Kirchhoff's current law in action. Each of these currents either is 0 or is found from $+V_{ref}$ divided by the series resistance (R_1 - R_4). For example, current $I_1 = +V_{ref}/R_1$ when S_1 is connected to $+V_{ref}$; I_1 is 0 when S_1 is connected to ground. In other words, when input "bit" B_1 is 0, $I_1=0$; when $B_1=1$, $I_1 = +V_{ref}/R_1$. The same is true for the

other currents. Study the example in Table I to see how these currents add when a binary word is applied by closing the respective switches.

The R-2R ladder

Although the BWL was once popular, the R-2R ladder in Figure 2 is currently the most popular in practical DACs. The reason: Resistances get too high and currents too tiny for low-cost practical circuitry when the BWL is extended more than a few bits. The R-2R ladder is a resistor network in which the elements have a 2:1 ratio to each other. For example, $R=10\Omega$ and $2R=20k\Omega$.

Provided that R_L is much larger than R , we can evaluate Figure 2 as a collection of voltage dividers. For example, if S_1 is closed, the output voltage V_o is $(+V_{ref})(R_L)/(R_L + 2R)$. Similar calculations find the voltage dividers for each of the other switches, which contribute successively less to the total output voltage when all switches are closed. Although the arithmetic is beyond the scope of this article, the

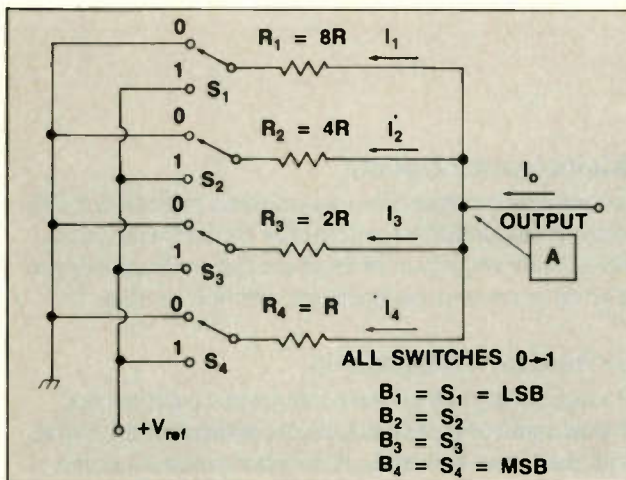

Figure 1. In the binary weighted ladder DAC, the output current is the sum of I_1 , I_2 , I_3 and I_4 . These currents are determined by the switches. For example, I_1 is 0 if S_1 is connected to ground. If S_1 is connected to $+V_{ref}$, $I_1 = +V_{ref}/R_1$. In other words, when input "bit" B_1 is 0, I_1 is zero; when B_1 is 1, $I_1 = +V_{ref}/R_1$.

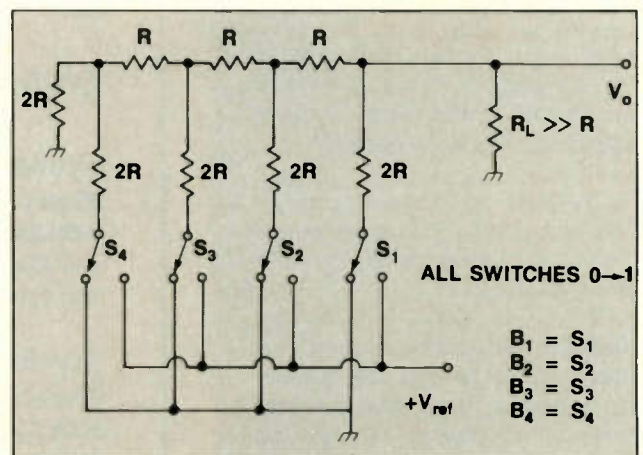

Figure 2. The R-2R ladder DAC is a resistor network in which the elements have a 2:1 ratio to each other. If R_L is much larger than R , the figure can be evaluated as a collection of voltage dividers. A voltage reference can be found for each of the switches. For example, if S_1 is closed, the output voltage V_o is $(+V_{ref})(R_L)/(R_L + 2R)$.

voltage builds up in a binary manner dependent on the individual switch settings.

How accurate is it?

The circuits in Figures 1 and 2 are equivalent to actual DAC circuits. In practical DACs, the switches are replaced with solid-state electronic switches, as is shown in Figure 3. When the base of transistor Q_1 is high (1), the transistor is turned off and V_{ref} is connected to the resistor load.

An example of an R-2R ladder DAC is shown in Figure 4. The active elements, A_1 and A_2 , are operational amplifiers connected in a unity-gain inverting follower configuration. Although you can get away with using devices from the low-cost 741 family for A_1 , it is not a good practice in a precision DAC. It would be better to use either a premium device or a BiMOS device such as the RCA CA-3140.

A precision reference voltage (or current) source is required for accurate DAC conversion, and for most practical designs this voltage will be at a level of +1.25V, +2.56V, +5.00V or +10.00V. Current levels between 500 μ A and 10mA are also sometimes used in current-output DACs.

The accuracy of the converter is dependent upon the precision of the reference voltage source. There are other sources of error, but if the reference is poor, there is no hope for any other factors to be effective in improving the performance of the circuit. An expensive 12-bit DAC driven from a voltage reference whose accuracy and temperature drift specifications only support 8 bits of resolution is still only

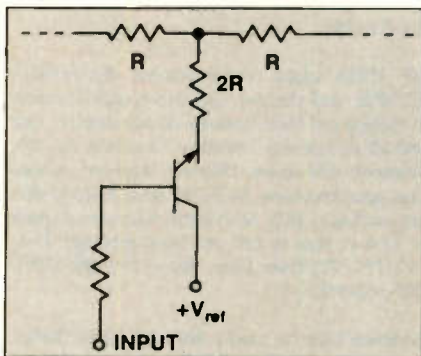

Figure 3. In practical DACs, the switches are replaced with solid-state electronic switches. When the base of transistor Q_1 is high (1), the transistor is turned on and V_{ref} is connected to the resistor load.

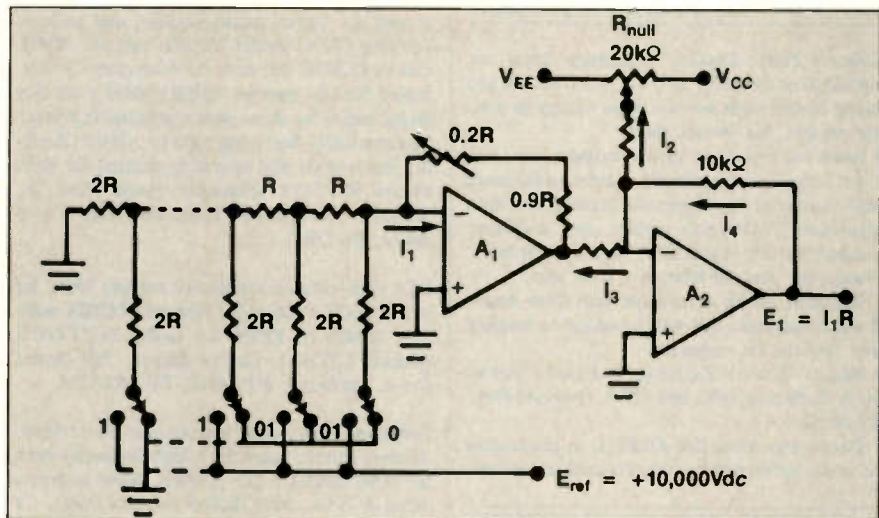

Figure 4. In this R-2R ladder DAC, the active elements, A_1 and A_2 , are operational amplifiers connected to a unity-gain inverting follower configuration.

Table 1.
How currents add when a binary word is applied

	1 1 0 1	
B_4		B_1
B_3		B_2
$I_o = I_4 + I_3 + I_2 + I_1$ $I_o = +V_{ref}(1/R_4 + 1/R_3 + 0/R_2 + 1/R_1)$ $I_o = +V_{ref}(1R + 12R + 0 + 1/8R)$		
<p>If $V_{ref} = 10.00Vdc$ and $R=1,000\Omega$ (typical values), then:</p> $I_o = +V_{ref}(1/1k\Omega + 1/2k\Omega + 0 + 1/8k\Omega)$ $I_o = +V_{ref}(0.001 + 0.0005 + 0 + 0.000125)$ $I_o = (10.00Vdc)(0.001625) = 0.01625A = 16.25mA$		

8-bits worth of good, despite the extra bits. A 12-bit DAC has 4,096 discrete digital numbers to contribute to V_o (1-LSB = $V_{ref}/4096$). For a 10V reference voltage, therefore, the 1-LSB voltage is 2.44mV. A reference source that puts out 10.2Vdc instead of 10.0Vdc has a starting error of 200mV/2.44mV, or about 800% of the 1-LSB voltage.

Although almost any precision voltage regulator can be pressed into service as the reference, it is a simple matter to use the Precision Monolithics REF-01/REF-02 devices for 6- and 8-bit machines. These IC devices are specially designed for this application, and they are easily trimmed to the required reference potential.

Returning to Figure 4, consider the circuit action under circumstances where various bits are either high or low. If all bits are low, then the output voltage I will be zero. The value of the

output voltage is given by $I_1 \times R$, and when all bits are low, the current is zero. In practical circuits, however, there might be some output voltage under these circumstances because of offsets in the operational amplifier, the R-2R ladder and the electronic switches. These voltages can be nulled to zero output voltage in A_2 when bits are intentionally set to zero (or simply ignored, if the offset is negligible).

If the most significant bit (MSB) is 1 (set high), the output voltage will be approximately $\frac{1}{2}V_{ref}$. If the MSB is turned on (set to high) and all others are low, the output will be $\frac{1}{4}V_{ref}$. The least significant bit (LSB) would contribute $(\frac{1}{2^N})(V_{ref})$ to the total output voltage.

Now that you understand how the DAC works, you're ready for next month's topic, analog-to-digital converters, which sometimes use DACs as an integral component.

ES&T

Readers' Exchange

Editor's Note: Readers' Exchange items are published in the order they are received. We are happy to offer this service at no charge to you, our readers, but we ask that:

- Items are typed (or legibly written).
- You include your name and address on the same page as your ad (envelopes and contents are often separated). Please also include your telephone number (specify if you don't want it published). Using your peel-off label is a good idea.
- You limit any ad to no more than three items. If space demands, ads will be edited to roughly four lines in the magazine.
- Mail to: Readers' Exchange, Electronic Servicing & Technology, P.O. Box 12901, Overland Park, KS 66212.

Please remember that **ES&T** is in production six weeks to two months ahead of publication date.

WANTED

Heathkit ET-3400-A Microprocessor Trainer, in excellent condition, with schematic and manual, if available. Will pay \$100 (quote asking price). *O. Sellers, 7308 Franklin Drive, Bessemer, AL 35023.*

Tektronix 146 NTSC signal generator (or equivalent); any flying-spot test equipment such as B&K nos. 1000 and 1076, Hickok 760 (or other make); large, 4-page surplus electronic listing sale—2 stamps. *D. Test, Box 9064-EST, Newark, NY 07104.*

Fluke model 75 or 77 multimeter; Heathkit model 5283 signal tracer. *George John Demaris, 7387 Pershing Ave., Orlando, FL 32822-5743; 407-277-3746.*

Schematic or Xerox copy of schematic for Emerson model EC194 color TV; Emerson doesn't have it and Photofact #2493 (EC194C) is much different. Must be EC194 exactly. Will pay \$8 for just the schematic. *Augustine's TV/Radio Service, 530 N. 9th St., Reading, PA 19604; 215-372-5438.*

Opening new shop and need test equipment of all kinds. Bonus for CRT rejuvenators. Fast cash—no hassles. *J. Cruz, Box 3974, Langley Park, MD 20787.*

Sony model TC-255 reel-to-reel. Need one S-101, one S-102 and two 25D-28. *Bob Tune, 18 Tottenham Court, Baltimore, MD 21234; 301-668-3928.*

Transistor testers: Eico model 680, B&K model 520-B, Century model TT-2; electronic analyzers: Moss Electronics model 640, Weston model 769; Century model CT-1 condenser tester, model SRT-1 in-circuit rectifier tester; model 435 Eico-scope with demodulator probe PSD and direct probe PD or a low-capacity probe PLC; pre-war record player manual supreme; radio servicing course—advanced radio servicing supreme; Rider's manual, volume 23; servicing receivers, by means of resistance measurements, by Rider; schematic diagram for General Electronic Dist. Co. model KT-30 channel analyzer; case and dial

pointer for Philco model 49-900; dial scale of Radiator (RCA) model 76ZX11, part no. 72903, chassis RC1058; dial scale for Telefunken Caprice, model 5051-W, part no. 18751D59NR1 (will buy junker radios for above parts at reasonable prices); Modern Radio Servicing 1935 by Alfred Ghirardi; instructions and operating manual for RCA model WT-501A transistor tester. *Paul M. Williams, 2364 Beaver Valley Pike, New Providence, PA 17560.*

RCA high-voltage transformers: number 79642 for model 21-CT-55 color TV (chassis CTC2B), numbers 100409 or 101959 for model 21-CT-662U (chassis CTC4A). *George Mayne, 307 Moxon Drive, Rochester, NY 14612; 716-865-5227.*

Scopitone films, parts and service information; jukebox service manuals; a high-frequency horn for AMI model F-120 jukebox. *Mike Zuccaro, Voice & Video, 5038 Ruffner St., San Diego, CA 92111; 619-560-1166.*

Sam's CB 273-274. *L. Jackson, Rt. 2, Box 2991, Hamptonville, NC 27020; 919-468-2758.*

Hickok model 292X signal generator in new condition and price. *Paul Caputo, 637 W. 21st St., Erie, PA 16502.*

Sams CB books and other Photofact books and folders. *Nancy Hauver, 34 Burlington Ave., Rochester, NY 14619.*

Good working fly for RCA CTC 40P. *D.J. Aijala, 50 Fir Circle, Babbitt, MN 55706.*

TV Photofacts above #2000. Please send your list and price. *H.L. Morrison, P.O. Box 326, Stony Point, NC 28678; 704-585-9968.*

Schematic and/or service manual for Panasonic model PV-1360 VCR. Will buy or copy and return. *Mike Richards, 322 Main St., Muleshoe, TX 79347; 806-272-3113.*

Manual or schematic for Power Designs model TW 5005 dual power supply. *W.J. Froehlich, Box 271, Westfield, NJ 07091.*

B&K model number 2902 substitution box. Please state condition and price. *John P. Caputo, G.P.O., P.O. Box 3175, Brooklyn, NY 11202-0064.*

Schematic for Paco model 70 VTVM; operation manual for EICO model 944 flyback and yoke tester. Will pay for copy or will copy and return. *Gerard O'Gara, 11 Crag Lane, Levittown, NY 11756; 516-731-4075.*

Volume control with switch for a Zenith Transoceanic Radio. The part number is 63-7135, 235848. *Frazier's Home Furnishings, 30753 Lake Logan Road, Logan, OH 43138.*

Tunnel diode, 1N3712 (obsolete). *R.N. Sharpe, 46 Slinn Bay, Regina, Saskatchewan, Canada S4R 6L6.*

Table shear for cutting PC boards up to 12 inches or longer. Also interested in other PC fabrication equipment. *Casey Shooper, 6540 W. 28th Place, Berwyn, IL 60402.*

FOR SALE

Heath VTVM, \$65; Northeastern 718 100MHz-10GHz RF sign. gen./freq. meter, \$70; Wahl ISO-TIP 60 portable iron, \$20; Dolphin Universal control RCA/MOT, \$15. Send legal-sized SASE for more info. *J.C. Estabrook, P.O. Box 5476, Cheyenne, WY 82003; 307-635-0220.*

Conar equipment: TVOM, \$65; 224 tube tester, \$105; 5MHz freq. counter, \$20; variable regulated power supply, \$100; 452 2-meter transceiver, \$150; electronic parts. Send legal-sized SASE for more info. *J.C. Estabrook, P.O. Box 5476, Cheyenne, WY 82003; 307-635-0220.*

Jerrold FD-30 lab coax switch, \$45; Midland SWR/field strength meter, \$10; Sams CB, Scanner, AR, MHF, TR, TV manuals; Motorola 2-way service manuals; misc. CB, Auto Radio & Stereo and Component Stereo service manuals; misc. new consumer electronics/CB products at dealer cost closeout. Send legal-sized SASE for more info. *J.C. Estabrook, P.O. Box 5476, Cheyenne, WY 82003; 307-635-0220.*

Sencore VA-62 video analyzer with VC-63 accessory, test leads, manuals and probes, including TP212 HV probe. Perfect condition, \$2,900, or will trade for Sencore SC-61 scope. *Michael E. Carter, NCS Box 7, FPO NY 09539.*

Retired, must sell: large quantity SAMS, \$18.50/10 (#1400-#2000); tubes, yokes, flies, test equipment, modules. *Henry Weymouth, P.O. Box 637, W. Haverstraw, NY 10993; 201-248-1176 or 914-942-2173.*

Tektronix RM547 lab scope with model CA 24MHz dual-trace pre-amp and all manuals; Tucker Electronics 87/88 Reference Guide. Price \$1,100, perfect condition, sell for \$525 plus shipping. *Leo Morin, 4622 S. 375 East, Ogden, UT 84405.*

Most-often needed radio manual, 1957 Supreme reprint, \$500 plus postage. *Paul M. Williams, 2364 Beaver Valley Pike, New Providence, PA 17560.*

TeleMatic 10J106B test jig with focus supply and 31 adapters to service many major brands, \$475; B&K 467 CRT restorer/analyzer with 27 popular adapters, \$375. Both in good condition. *John's TV, 34 Hillside Ave., Souderton, PA 18964; 215-721-1563.*

HP 1722A scope (serial number 1643A01020) 275MHz, dual channel, dual sweep, digital readout of voltage and time, includes documentation, cart and all accessories, excellent condition, \$1,250; Tektronix 454 scope, 150MHz, with documentation, good condition, \$475; HP 651B 10Hz-10MHz test oscillator, \$125. Send SASE with partial check to hold an item or call and leave message. *Denny's TV, 2725 Eden Lane, Rapid City, SD 57701; 605-342-8852.*

Simpson Electric model 467 true RMS DMM, measures to 1,000Vdc, 750Vac, 2A ac-dc, 20M Ω , includes leads and battery, \$100; Dumont model 1062 scope, 50MHz bandpass, dual vertical inputs, main and delay sweeps, 100% solid state, \$495; Deihl Mark III scanner, new, turn on any shut-down TV, \$250. Add \$10 for insured UPS

shipping, COD is OK, too. *Fred Jones, 407 Morningbird Court, Niceville, FL 32578; 904-678-1803.*

Recorders: Travis Tapak Newscaster, Sony TC-102, Wollensak Revolve 3000; TVs: Sony KV 1201 complete B.O. Jug, Admiral M25 and M30 chassis, RCA CTC 74 chassis, GE 19QA chassis, GE UA chassis B&W complete, GE L2-C2 chassis. *D.J. Aijala, 50 Fir Circle, Babbitt, MN 55706.*

Score SGI65 stereo analyzer in original carton, with cables, \$500; Dynatracer DT-1 component checker, with cables and instructions, \$90; Heathkit color bar and dot generator, no cables, \$30; EICO model 249 VTVM with cable, \$45. Add shipping. *J.S. Lawrence, Jr., Mountain City TV, 2646 S. Broad St., Chattanooga, TN 37408; 615-756-5430.*

B&K model 177 VTVM with manual and Score model FEL60 VOM with manual, both need repair and adjustment, \$100 for both; RCA Institutes television home study course with TV kit, \$200. Add shipping. *Sal Cribaki TV and Stereo, 1312 Well Drive, Camp Hill, PA 17011; 717-763-4547.*

Two Score VA48 analyzers, \$800 each + shipping. *Wally Lorenc, P.O. Box 116, Minooka, IL 60447; 815-467-4555.*

Heathkit model IT-1121 semiconductor curve tracer with manual, \$45; Heathkit model IT-21 tube tester, \$50; B&K model 1075 analyst—no manual or slides, \$45. Add postage. *Kenneth Miller, Miller TV, 10027 Calvin St., Pittsburgh, PA 15253; 412-242-4701.*

Color picture tubes, \$25-\$85; modules, flybacks and triples; other tubes and parts. *All Electronics Repair Service, 84-39 120th St., Queens, NY 11415; 718-847-7965.*

Score VA62 universal video analyzer; EX231 expander jack; VC63 VCR test accessory; NT64 NTSC pattern generator. With manuals and leads, in excellent condition—EX231, VC63 and NT64 have never been used. \$2,600 + shipping. *Darrell Carter, Route 1, Box 413, Screven, GA 31560; 912-579-6320.*

B&K 466 CRT tester and restorer with 20 adapters, \$250; SAMS Photofacts, #1000 and up, many still sealed, \$5 each, 25 or more, \$4 each. *W.J. Froehlich, Box 271, Westfield, NJ 07091; 201-232-3867.*

Topaz 2500VA Ultra Isolator isolation transformer, \$200; Heathkit IO101 vector scope and dot bar generator, \$100; Wavetek SAM I signal analysis meter, 4MHz to 300MHz, with case, excellent

condition, \$500; Global LTC-2 Logical Analysis test kit, with all probes and case, \$125. Add shipping. *Thor Electronics (Ray); 603-679-5163.*

Sams Photofacts from #1150 to present date, #2571; other equipment. *Jack L. Stewart, Stewart's Television, 3444 Charlemagne Drive, Decatur, GA 30034; 404-987-2522.*

Score equipment: VA62, \$2,200; VA48, \$500; LC53/FC221, \$500; CR70, \$600; VC63, \$250; VC64, \$200—all like new, in original cartons, with manuals; BK520B transistor tester, \$75. You pay shipping. *Tom Condon, 718-351-5765.*

B&K model 820 digital capacitance meter, \$85; B&K model 510 transistor and SCR tester, \$80; Lectrotech color bar/vectorscope generator, \$55. All equipment in good working order, with leads and instruction manuals. *Mr. Lurry, 4924 69th St., San Diego, CA 92115; 619-462-7445.*

Sylvania Chek-A-Color model CK3000 color receiver test jig, tests more than 10,000 models and 62 brands of color sets, several CRT adapters included, new, never used, \$150; B&K model 415 sweep/marker generator, \$125. Excellent condition, prices plus shipping, UPS collect. *P.N. Booth, Box 776, Wofford Heights, CA 93285; 619-376-2895.*

ESV

Classified

Advertising rates in the Classified Section are \$1.55 per word, each insertion, and must be accompanied by payment to insure publication.

Each initial or abbreviation counts as a full word.

Minimum classified charge \$30.00.

For ads on which replies are sent to us for forwarding (blind ads), there is an additional charge of \$35.00 per insertion to cover department number, processing of replies, and mailing costs.

Classified columns are not open to advertising of any products regularly produced by manufacturers unless used and no longer owned by the manufacturer of distributor.

FOR SALE

TV TOUGH DOGS: 300 symptoms and cures. Send \$7.95 to DAVIS TV, 11772 Old Fashion Way, Garden Grove, CA 92640. 10-87-tfn

AUTOMOBILE RADIO, TAPE and amplifier repairs most manufacturers. Quick turn around time. Send your units to us at, Laran Auto Electronics, 188 W. Lincoln Avenue, Mount Vernon, New York 10550. Inquiries: P.O. Box 466, Bronx, New York 10475. 914-664-8025, 800-223-8314. 5-88-tfn

INTEGRATED CIRCUITS—Lowest prices on Admiral, GE, NAP, Philco, RCA, Sears, Sylvania, and Zenith types. Write P.E.C. Box 894 Union, NJ 07083. 03-88-6t

VHS-VCR REPAIR SOLUTIONS VOLUMES I, II, III. Each contains 150 symptoms and cures, cross reference chart, free assistance. Each \$11.95, any two \$19.95, all \$29.95. Eagle Electronics, 52053 Locks Lane, Granger, IN 46530. 5-88-tfn

TV/VCR "Tuff Tips" listed by mfg. and model. 1st or second edition. 200 tips per edition, \$10.95, both editions \$19.95. TV Tips only, 1st or 2nd edition \$5.95, both editions \$10.95. VCR Tips only, 1st or 2nd edition, \$6.95, both editions \$12.95. **TECH CURES**, 4825 Fredericksburg Road, San Antonio, Texas 78229. 6-88-tfn

TV/VCR Failure Histories—Multiple cures for most problem areas. Send \$6.95 with mfg. and model number to **TECH CURES**, 4825 Fredericksburg Road, San Antonio, Texas 78229. Money will be refunded with free sample, if model is not on database. 6-88-tfn

VCR CROSS-REFERENCE listing for the following electronically-similar manufacturers: RCA, GE, Sylvania, Panasonic, Quasar, Magnavox, Philco, and J.C. Penney. Send \$13.95 to **TECH CURES**, 4825 Fredericksburg Road, San Antonio, Texas 78229. 6-88-tfn

PHOTOFACTS: Individual folders #1400 \$3.00. Above #1400 \$5.00. Sent same day first-class post-paid. Loeb, 414 Chestnut Lane, East Meadow, NY 11554. 6-88-3t

SONY-TRINITRON Rebuilt Picture Tubes are now available. All tubes shipped U.P.S. No Charge. We buy all Sony duds. Rochester Kinescope, 716-235-0750. 11-87-tfn

TV TROUBLESHOOTING: 160 Problems—Solutions on models/chassis in service today. Nothing old listed. Complete narrative on each solution. Also, 15 effective steps to easier repairs, \$12.00. Jones, Box 702, Niceville, FL 32578. 2-88-6t

VCR REPAIR COURSE—HOME STUDY—Details \$2.00 (refundable with order) VCR repair histories \$10.95. Western Hemisphere Enterprises, Box 673, Commack, N.Y. 11725. 7-88-1t

FOR SALE: Score; SC61 Scope, SG-165 Stereo Analyzer. Mint condition, factory boxes—from estate. Jim Phillips, 614 Washington Ave., Defiance, Ohio 43512. (419) 782-8591. 7-88-1t

O'SCOPES. TEKTRONIX. 465 100MHZ \$1000. Tektronix. 475 200MHZ \$1600. HP1740A. 100MHZ \$1000. Much more equipment available. Cal-Scope, 473-707 Macara Ave., Sunnyvale, Ca. 94086. (408) 730-4573. 7-88-3t

AAA ELECTRONICS: Parts NTE, chemicals, supplies. For flyer write to 2336 S. Presa, San Antonio, Texas 78210. 7-88-1t

SCORE Test Equipment, like new. SC61 Scope—\$1995; VA62 Video Analyzer—\$2295; NT64 NTSC Generator—\$249; VC63 VCR Head Subber—\$249; LC53 capacitor/inductor tester—\$299; CR70 CRT Analyzer and Restorer—\$695. Also BELL & HOWELL large Micro Fiach Viewer—\$175. Will take \$5500 for everything. H.E.C., P.O. Box 1820, Vernal, Utah 84078, 801-789-1997 ask for Mike. 7-88-1t

BUSINESS OPPORTUNITIES

OWNER RETIRING electronics and home appliance business for sale with repair parts and equipment, trade fixtures, office equipment, delivery van plus trade in inventory. Five year lease of down town store available in north central Wisconsin. Subject to inventory on day of sale. \$25,900.00. Woller Realty, 102 S. Court St., Merrill, WI 54452. Phone 715-536-5725. 7-88-2t

TV/STEREO/CB SALES & SERVICE. Good income, good location. So. central Pennsylvania. Approximately \$25,000. Call Tom, (717) 637-7003. 7-88-1t

MARGATE, FLA. 10 miles NW of Ft. Lauderdale. One man TV repair shop grossing \$60,000 plus. Established 12 years. New Score equipment, SAMS 1400 to present. \$25,000. (305) 972-9380 after 1:00 PM. 7-88-1t

TV/VCR REPAIR SHOP—Good lease, excellent building, large parts inventory, tools, equipment. Got to go fishing sale. \$6,000.00. Rogue River, Oregon, 503-582-4877. 7-88-1t

**PERSONALIZED 24-HOUR SERVICE
ON OVER 10,000 ELECTRONIC
COMPONENTS & PRODUCTS...**

CALL TOLL FREE

IN
1-800-558-9572 WIS 1-800-242-9553
24 HOUR ORDERING: FAX: 414/473-4727



PROJECTOR-RECORDER BELT CORP.
P.O. Box 176 • Whitewater, WI 53190
TLX 4994411 PRBUSA

Circle (28) on Reply Card

TV "TECH'S" DREAM

TEST & RESTORE EVERY CRT on the market.... without every buying another adaptor socket for your CRT tester. Fits ALL makes & models. MONEY BACK GUARANTEE. Over 12,000 sold. Complete Patented Kit, with Sockets & Setup Book.... Only \$63.95 ppd. A one-time investment for life!! Visa/MC/COD's/Checks.

FREE CALL 1-800-331-9658

DANDY MFG. CO.

2323 Gibson Street Muskogee, OK 74403

Circle (26) on Reply Card

**HAND REMOTE REPAIR
LA GUARDIA ENT**

5882 Rich Hill Way
Yorba Linda, CA 92686
(714) 579-1276

90
Day
Warranty
New Battery
Included

- Call for pricing
- 24 hr. turnaround time
- Return freight pre-paid

Circle (27) on Reply Card

"Tech's Guide To Pricing"

updated new 5th edition...a framework for setting rates that apply to Hi-Tech products...a formula that guarantees SUCCESS!

Call Toll Free for details 8/5
1-800-228-4338 CST

Circle (29) on Reply Card

**HELP WANTED:
Computer Magazine Editor**

Responsibilities include editing monthly business/technical trade magazine read by field and in-house service managers. Involves travel and interaction with industry authors, associations and magazine advertisers.

Ideal candidate is a manager in a small to mid-size computer service company or department with primary strengths and knowledge in the daily operations of a service business.

Knowledge of computer repair and technology required. Writing and editing skills helpful.

Send resume to: Personnel Director, Intertec Publishing, 9221 Quivira Road, Overland Park, KS 66212.

EOE M/F/H

Ad Index/Hotline

Company	Page Number	Reader Service Number	Advertiser Hotline
American Reliance	15	11	800/654-9838
Atrix, Inc.	57	24	800/222-6154
Beckman Industrial Corp.	IFC	1	619/495-3200
C + S Sales	17	12	800/292-7711
Chemtronics, Inc.	1	3	800/645-5244
Consolidated Electronics, Inc.	55	23	800/543-3568
Dandy Mfg. Co.	68	26	800/331-9658
ETA	55		
Fluke, John Mfg. Co., Inc.	5	6	800/227-3800
Fordham Radio Supply Co.	7	13	800/645-9518
Hitachi Sales Corp. of America	21	14	516/921-7200
ISCET	59		817/921-9101
Kelvin Electronics	13	10	800/645-9212
Laguardia Enterprises	68	27	714/579-1276
Leader Instrument Corp.	3,11	4&5,8&9	800/645-5104
MCM Electronics	49	20	800/543-4330
NESDA	49,61		
NTE Electronics, Inc.	25	15	800/631-1250
Parts Express Int'l Inc.	47	19	513/222-0173
Philips ECG	27	16,35,36	800/225-8326
Projector Recorder Belt Corp.	68	28	800/558-9572
PTS Corp.	41	17	812/824-9331
Sencore, Inc.	IBC	2	800/843-3338
Sperry Tech, Inc.	68	29	800/228-4338
Tool Kit Specialists, Inc.	51	21	800/621-0854
Tronix, Inc.	51	22	313/939-4710
TSC Service Corp.	68	30	800/333-4872
U.S. Instrument Rentals	43	18	800/824-2873
U-CAN-DO VCR Educational Products Co.	59	25	513/548-6113
Zenith	BAC		

Picture Tubes
American - Foreign - Monitor
Price covers most 13" to 25" picture tubes. CALL US for a PRICE QUOTE. \$49.95
•Quality Manufactured •Fast Exchange/Repair •1-Yr. Warranty •Check our SONY PRICES!
•Use your Master Card/Visa/COD/Check*** Call 800-333-4872
TSC/CENTEC 303 N. Curry Pike, Bloomington, IN 47401 Telephone 812-334-8411

Circle (30) on Reply Card

ELECTRONIC SERVICING & TECHNOLOGY (ISSN 0278-9922) is published monthly for \$19.49 per year by Intertec Publishing Corp., 9221 Quivira Rd., Overland Park, KS 66215. Second-class postage paid at Shawnee Mission, KS and additional mailing offices. POSTMASTER: Send address changes to ELECTRONIC SERVICING & TECHNOLOGY, P.O. Box 12960, Overland Park, KS 66212.

ADVERTISING SALES OFFICES

ELECTRONIC
Servicing & Technology

KANSAS CITY, MISSOURI
Greg Garrison, Sales Manager
P.O. Box 12901
Overland Park, KS 66212
Phone: (913) 888-4664
Fax: (913) 888-7243
Telex: 42-4156 INTERTEC OLPK

OXFORD, ENGLAND
Nicholas McGeachin
Roseleigh House, New Street
Deddington, Oxford OX5 4SP
Phone: (0869) 38794
Telefax: (0869) 38040
Telex: 837469 BES G

TOKYO, JAPAN
Haruki Hirayama,
EMS, Inc.
Sagami Bldg., 4-2-21, Shinjuku,
Shinjuku-ku, Tokyo 160, Japan
(03) 350-5666
Telex: 2322520 EMSINCJ
Cable: EMSINC PERIOD

FREWVILLE, SOUTH AUSTRALIA
John Williamson
Hastwell, Williamson, Rep. Pty. Ltd.
109 Conyngham Street
Frewville 5063
South Australia
Phone: 799-522
FAX: 08 79 9735
Telex: AA87113 HANDM

With Just One Probe Hookup You Can Confidently Analyze Any Waveform To 100 MHz, 10 Times Faster, 10 Times More Accurately, Absolutely Error Free, Guaranteed Or Your Money Back . . .

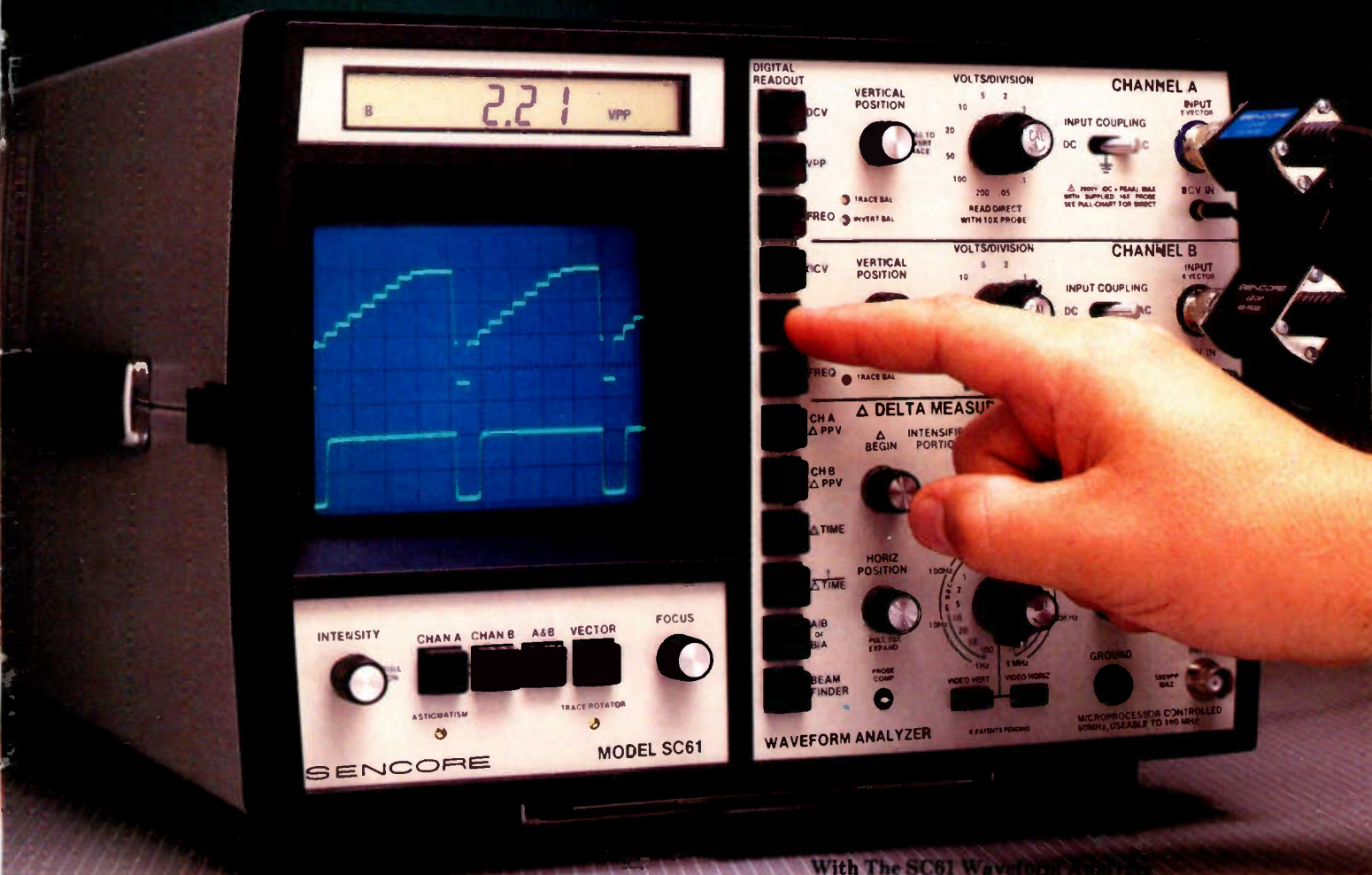

With The SC61 Waveform Analyzer
\$3,295.00 PATENTED

Promises of increased productivity from other oscilloscopes fade fast when compared to the speed and accuracy of the SC61. Eliminate the confusing menus, cursors and complexity of regular oscilloscopes at the push of a button. Here's what the SC61 does for you:

Analyze Waveforms Easily

- Accurate Waveform Display - 60 MHz Bandwidth (usable To 100 MHz) To Test The Latest Digital Circuits.
- Rock-Solid Sync - ECL Logic Circuits And Differential Amplifiers Give Fiddle Free Operation.
- Four Times The Measuring Range - Measure From 5 mV To 2000 Volts (3000 Volts Protection) For Expanded Signal Handling.

Autotracking™ Digital Readings Analyze The Whole Signal

- Autoranging DC Volts Through Single Probe, Even With AC Coupled.
- Automatic Peak-To-Peak Volts - Even If Variable Control Is "Out Of Cal".
- Automatic Frequency Measurements Without Sensitivity Adjustment Or Range Switching.

Digital Delta Tests Analyze Any Part Of The Signal.

- Delta Peak-To-Peak Volts - Peak-To-Peak Volts Of Any Part Of The Signal.
- Delta Time For Any Time Reading - Including Delay Between Traces
- 1/Delta Time - Frequency Of Part Of The Signal - Finds Sources Of Interference Or Ringing.

Frequency Ratio Test - Tests Multiplier And Divider Circuits

Easy To Use - Human Engineered Controls And Virtually No Graticule Counting Or Calculations

The SC61 is designed to give you the measurements you need - fast. We make one claim:

"Try the SC61 on your bench for 30 days. If it doesn't cut your present scope time in half, send it back for a complete refund, no questions asked."

Try the SC61 for 30 days, and discover true troubleshooting speed.

Call 1-800-843-3338
In Canada Call 1-800-851-8866

**For your own reputation
and in your customers' best interest
always insist on**

Genuine Zenith

Remanufactured Replacement Parts

Reconditioned and Serviced for Reliability

by Zenith People

as Knowledgeable and Dedicated as

Those Who Made the Originals!

One of the easiest, fastest, and surest ways for you to preserve the pedigree and maintain the quality of the Zenith products you service is with genuine Zenith replacement parts.

And at no time is this more critical than when you replace the more sophisticated components like modules, tuners, channel selectors and sub-assemblies.

Your participating Zenith parts distributor will supply you with a replacement remanufactured, reconditioned and serviced for reliability by Zenith people as dedicated and knowledgeable as those who made the original.

Equally important, the replacement module or sub-assembly you receive in exchange from your Zenith parts distributor

will most likely incorporate any Zenith factory-made modifications in effect at the time of remanufacture.

And nowhere else but in a participating Zenith parts distributor's Exchange Program can you get assurance that a replacement incorporates Zenith factory up-dates!

To learn the location of the Zenith R&R Exchange Counter in your area, write on your company letterhead and we will help you locate one that's nearby.

Risking an exchange for a Zenith replacement anywhere else doesn't make sense. Not when factory-fresh replacement modules and sub-assemblies are so readily available thru a Zenith parts distributor's Exchange Program! Write now!



The quality goes in before the name goes on.®