



# USER MANUAL

Benelli Bravo



This manual contains important safety, performance and service information. Read it before you take the first ride on your new bicycle and keep it for reference.





## Table of Contents

1. Preface.....	3
1.1 Welcome .....	3
1.2 Illustrations.....	3
2. Safety.....	3
3. Vehicle and parts.....	4
4. Quick Installation Instruction.....	5
4.1 How to set up the front wheel .....	5
4.2 How to set up the handlebar and display.....	6
4.3 How to install/remove the battery.....	7
4.4 Pedal .....	8
4.5 Adjust the handle bar position .....	8
5. Check before riding .....	8
6. Riding a Bravo.....	9
7. The display.....	10
7.1 850C button LCD color screen (LCD).....	10
7.2 ON/OFF operation .....	10
7.3 Pedal Assist Selection .....	10
7.4 Speed mode and mileage mode switch.....	10
7.5 Headlight switch/display mode switch.....	11
8. Technical documents:.....	12
8.1 Battery and Charger .....	12
8.2 Storage and Cleaning.....	13
8.3 Routine checkup and maintenance:.....	14
9. Technical Parameters .....	18
10. Legal documentation.....	18
10.1 Service and warranty .....	18
10.2 Warranty conditions.....	19
11. Fault and troubleshooting .....	22
12. Front Fender Installation.....	24



## 1. Preface

### 1.1 Welcome

Dear Benelli owner:

Thank you for your love of Benelli electric bicycles, and warmly welcome you to become a Benelli user. Before you start your journey riding with the wind, please read this user manual carefully.

### 1.2 Illustrations

Illustrations shown in this document may differ in detail from the exact configuration on your particular e-bike model. The illustrations are a general reference for instruction and description purposes only.

## 2. Safety

E-Bike laws differ by State - check your local laws and only ride in legally permitted areas. Use helmets, protective gear and always ride responsibly.

Bravo is suitable for hard ground roads, such as asphalt, bicycle paths or gravel roads. When driving on public roads, please follow the traffic rules. Bravo bike is not suitable for off-road driving, otherwise it may cause unpredictable consequences or accidents.

- 1) Please strictly abide by the traffic laws and regulations, prepare helmets, protective equipment and other protective equipment before riding, and pay attention to cycling safety.
- 2) It is strictly forbidden for people under the age of 16 to drive electric bicycles on the road;
- 3) Don't lend electric bicycles to people who are not suitable to ride this bicycle
- 4) When riding in wet weathers, the braking distance will be extended;
- 5) Avoid traveling in bad weather such as heavy rain/snow
- 6) Don't touch or use metal to touch the charging port on the bike, otherwise it will cause a short circuit.
- 7) Bicycles are vehicles with certain risks, break the rear wheel first, and then the front wheel in emergency braking, especially when the cycling speed is too high, you may fall over if you use the front brake suddenly. Please ride carefully.
- 8) Please consult your insurance company or insurance broker on the insurance coverage of riding an electric bike.
- 9) Do not park bikes in building lobby, evacuation stairs, walkways, and safety entrances.
- 10) Do not charge the bike in residential buildings, stay away from combustible, and do not charge for a long period of time.
- 11) Maximum load for this bike is 105kg, DO NOT carry more than 25Kg on the rear.

### 3. Vehicle and parts

## Benelli Bravo

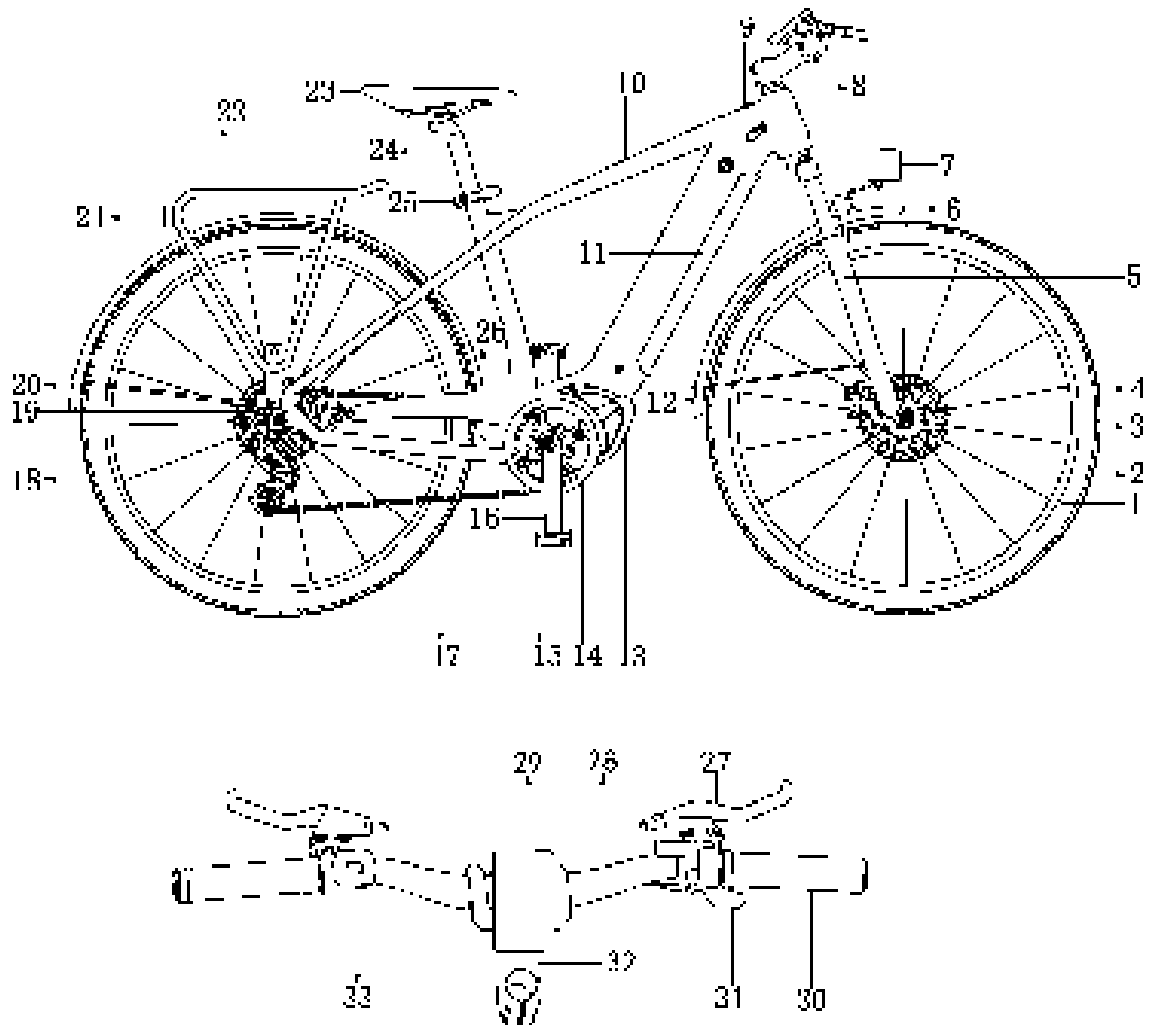

- |                  |                    |                  |                  |
|------------------|--------------------|------------------|------------------|
| 1、Tires          | 2、Rim              | 3、Front Hub      | 4、Brake Disc     |
| 5、Front fork     | 6、Front fender     | 7、Headlight      | 8、Headset        |
| 9、Power switch   | 10、Frame           | 11、Battery       | 12、Brake Caliper |
| 13、Central motor | 14、Crank Set       | 15、Pedal         | 16、Chainwheel    |
| 17、Chain         | 18、Rear derailleur | 19、Cassette      | 20、Rear fender   |
| 21、Rear light    | 22、Rear rack       | 23、Saddle        | 24、Seat post     |
| 25、Seat post     | 26、Chain cover     | 27、Brake lever   | 28、Handlebar     |
| 29、Display       | 30、Handle Grip     | 31、Thumb shifter | 32、Stem          |
| 33、Button        |                    |                  |                  |

## 4. Quick Installation Instruction

### 4.1 How to set up the front wheel



1. Insert the front wheel in-between the front fork, make sure the brake disc sits between the brake pads



2. Take the quick release lever, slide off the ends, and insert the lever rod through the hub from opposite side of the brake disc. Then, slide the spring and nut onto the rod, tighten the nut. Continue to tighten the nut while opening and closing the lever until a good resistance is achieved.
3. Make sure the lever is flipped up towards the frame to avoid snapping

## 4.2 How to set up the handlebar and display



4. Unscrew the cap from the handlebar holding stem, insert and adjust the position of handlebar. Then tighten the screw back with the cap to secure the handlebar in place.



5. Install the display on handlebar. Secure it in place by tighten the screws

6. Then connect the blue wire on display to blue wire on bike and green wire on display to green wire on bike.



7. Install the control button on the left side of the handlebar.

### 4.3 How to install/remove the battery

1. Support the battery cover with your hand, as the battery might drop after theit is unlocked.
2. Insert the key into the keyhole near the handlebar, rotate 90° counterclockwiseto unlock the battery.



3. Then insert/remove the battery. When installing the battery, first align the bottom end of the battery with the holder, then move the upper end of the battery closer to the holder and apply force until you hear a "click" sound.



4. The battery switch is located at the bottom, click to turn on or off the battery

output.

#### 4.4 Pedal



Pay attention to Left and Right before installation

#### 4.5 Adjust the handle bar position



1. Please turn the handlebar up, down, left and right, and make sure that the handlebar is not loose.
2. Loosen the screws at ① to adjust handlebar alignment with the front wheel, ensure it is perpendicular to the front wheel. Loosen the screws at ② to adjust the handlebar position
3. When adjusting the height of the handlebar, make sure that the safety wire on the stem tube is not be exposed.



#### 5. Check before riding

The power circuit and lighting are working. The front and rear brake lever are working. The handlebars are tightened.

The front & rear wheels are tightened.



The tire pressure is normal.

Check the reflector for contamination before cycling.

## 6. Riding a Bravo

### How to start

Press the power on/off button, the motor starts. When you sit firmly on the bike, slowly rotate the throttle, and the bike will start moving, and then slowly accelerate.

### How to change gears

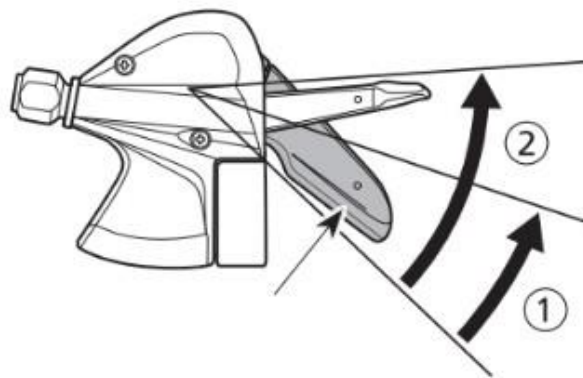

To speed up, start with a lower gear and shift to a higher gear as you speed up. When going uphill, use a lower gear.

On a flat terrain, use a higher gear.

### How to brake

- 1) Release the throttle and stop pedaling.
- 2) Squeeze the both brakes slowly and then tighten.
- 3) Do not brake or steer sharply. Emergency braking and sharp steering are the main factors causing sideslip or rollover, which is extremely dangerous. If only the front or rear wheels are braked, and the bike may slide horizontally, which is extremely dangerous.



## 7. The display

### 7.1 850C button LCD color screen (LCD)

Use function of LCD meter:

- 3.2 inch colour screen
- Speed
- battery level
- Mileage
- Time
- Headlight
- Brake
- Pedal Assist level

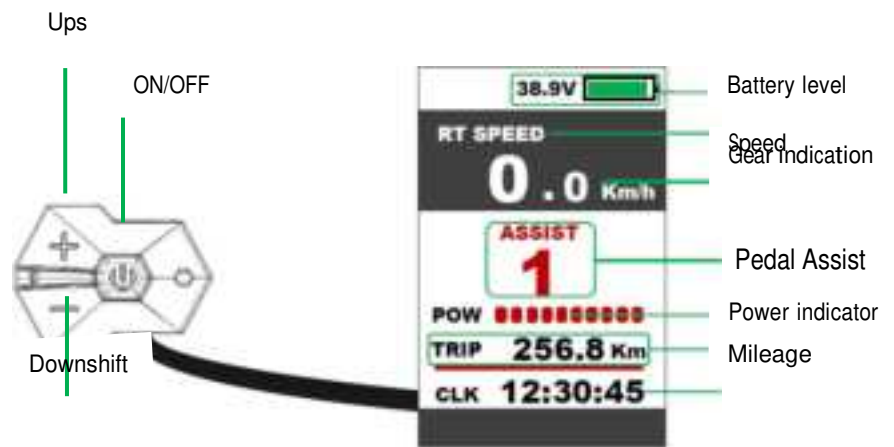

### 7.2 ON/OFF operation

1. To turn on/off the battery power, press the power button on the bike frame.
2. To turn on/off the display power, press and hold the power button on handlebar switch for 1 second
3. The display will turn off automatically if the ebike is left idle for more than 5mins .

### 7.3 Pedal Assist Selection

short press the "+" or "-" button to change the Pedal Assist level. The lowest is Level 0 without any assistance, and the highest is Level 3 with maximum assistance. The default is Level 1 when the e-bike is turned on.

### 7.4 Speed mode and mileage mode switch

1. short press the power button to switch the speed display information and mileage display mode, and the following information is displayed in a loop: averagespeed (AVG SPEED) → maximum speed (MAX SPEED) → real-time speed (RT SPEED) → cruising range (RANGE)→ Cumulative mileage (ODO) → riding time (TIME) → single mileage (TRIP)



Speed mode and mileage mode switch display interface

※The meter will automatically return to the real-time speed display state after 5 seconds

### 7.5 Headlight switch/display mode switch

Long press the "+" button for 1 second, the indicator turns on the lights (supported by the controller) and switches to display day/night modes. Long press the "+" button for 1 second again, the indicator turns off the lights and switches the display mode.

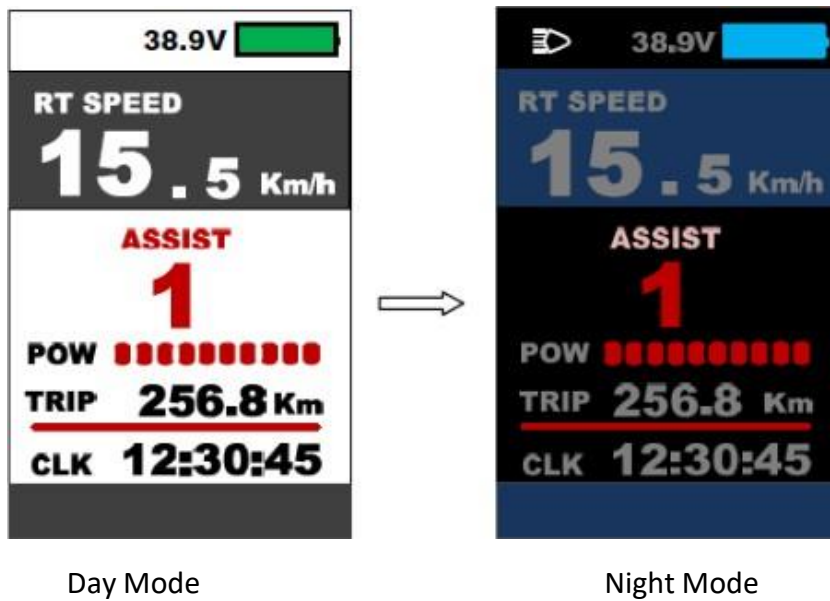

### Walk assistance mode (6km/hr walk)

Press the "-" button for 3 seconds, the bike enters walk-assistance mode, the display shows the real-time speed, Pedal Assist level is P. Release the button, the bike exits the walk assistance mode.

Brake indication: Braking

cut-off shows .

## 8. Technical documents:

### 8.1 Battery and Charger



1. The battery can be charged directly in the bike, or charged on its own.
2. Please fully charge the battery before first use, otherwise battery life may be reduced.
3. You can check the battery level by pressing the display at the bottom of the battery or the battery indicator on display.
4. Please turn off the battery when charging, which

5. Connect the charger to battery properly, before connecting on the wall plug to wall socket. The red light on charger indicates the battery is charging; while green light indicates that the battery is fully charged.
6. If the bike is not used for a long time, the power will gradually decrease due to natural discharge. Please regularly charge the battery, before it is exhausted.
7. If the bike will not be used for more than 1 month, the battery should be removed from the bike and stored separately. Please recharge it at least once every three months.
8. The capacity of the battery will decrease after every re-charge. It is normal to see a drop in range on a full charge after 6 months of frequent use. Please contact your dealer for battery replacement.
9. The operating environment is  $-20^{\circ}\text{C} \sim 60^{\circ}\text{C}$ .
10. The charging time is about 2-4 hrs. Do not charge the battery for more than 6 hrs.

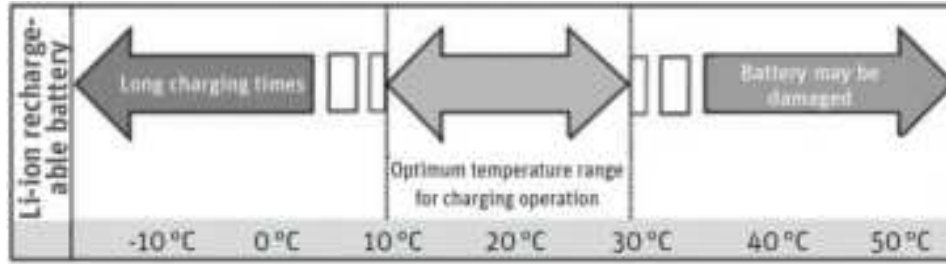

Charging times at different temperatures

**Warning**

- 1) The user must operate according to the instructions when charging;
- 2) Never use third party battery or charger for Benelli bikes.
- 3) When the charger is working, please place it in a safe, well ventilated place, out of reach of children.
- 5) Do not leave the charger connect to AC power supply when not charging. This is dangerous, and could cause fire hazards.
- 6) Do not cover the charger or adaptor when charging, please allow heat to dissipate easily.
- 7) Store charger and battery in a dry, clear box when not in use, keep away from small item that might fall inside the charging port.
- 8) Beware of falling and impact to avoid damage.
- 9) Do not disassemble or replace the parts in the charger by yourself. When replacing the charger, use original charger that match the lithium battery model.

**8.2 Storage and Cleaning**

Do not use excessive water to wash the plastic. Use a soft cloth with a neutral solution to wipe the dirt off the plastic shells. After that, wipe it dry with a clean soft cloth.

CAUTION: Do not use high-pressure water or air hoses for cleaning. It can force water into electric components, which may cause malfunctioning.

CAUTION: Do not wash the E-bike components with excessive water. If the internal electrical parts are infected with water, the insulator may corrode which leads to power-drain or other problems.

CAUTION: Do not use non-neutral soap solutions to wash plastic components. Non-neutral solutions may cause colour-change, distortion, scratching.

### 8.3 Routine checkup and maintenance:

In order to prolong the service life of the bike and enable maintain its safety and comfort, please check and maintain it regularly. When the bike is not used for a longtime, it should also be checked regularly. The new bike should be inspected by a professional once the milage passes 300Km. All inspection must be carried out in asafe and open environment. If an abnormality is found during regular inspections, please avoid using the e-bike before the issue is resolved.

#### Motors and controllers:

1. Regularly remove dirt from the lids on both sides of the motor to allow heat dissipation during motor work and extend the degaussing time of the motor, thus extending the life of the motor.
2. Regularly inspect and tighten the cover screws and nuts at both ends of themotor and shafts to avoid damage to the motor during riding.
3. Regularly go to bike servicing point to check the insulation of the motor wiring and the casing. If there is no insulation, find out the cause and repair it in time.
4. Regularly check whether the connecting plug-in of the controller is loose.
5. Regularly check whether the fuse box of the whole vehicle is loose, and deal withit in time if it is loose.
6. You should start and accelerate the bike slowly to reduce the impact of highcurrents on controllers, motors and lithium batteries and extend the life of electrical components.

#### Bike frame and parts:

1. Check whether the front fork is bent or damaged,
2. Move the handlebar up and down, if there is any usual noise, please consult aprofession bike servicing center.
3. Check front and rear brakes respectively
4. Check if the gear can be changed within the range without abnormal resistance
5. Do not disassemble the bike by yourself unless you have mastered thetechniques, so as not to damage other parts.

6. Use original spare parts, otherwise it may impair the function of the bicycle or cause damage.

#### Tyre:

1. Check the tyre pressure before riding.
2. If the tyre pressure is abnormal, check for cracks, damage and abnormal wear,
3. Stay away from stones, glass, nails or sharp objects on the ground when riding.
4. Tyre can be hot to touch after riding.
5. Replace the tyre when more than 2/3 of the tread on tyre groove are worn out.

#### Chain adjustment:

**Adjustments should only be performed with proper tools by a trained mechanic.** Please consult professional bike shops if you are unsure, incorrect chain adjustment can cause injuries when riding.

#### How to check the chain:

To check the chain tension, hold the chain in the middle section between the front and rear sprockets.

- Move the chain up and down to check the slack on the chain;
- There should be between 10-15 mm of vertical movement;
- If the movement is more or less, the chain tension needs to be adjusted.

#### How to adjust the chain:

**Please consult professional bike shops if you are unsure, incorrect chain adjustment can cause injuries when riding.**

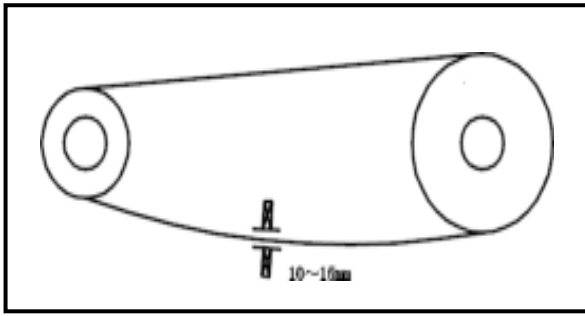

First loosen the rear axle nut and turn the adjusting nut to the left or right to correct the slack of the chain. While adjusting the chain, you must also keep the front wheel chain aligned with the rear. After adjustment, re-fix the rear axle nut, lock the adjustment nut and perform a final check to make the distance between the two sprockets is 10-15 mm.

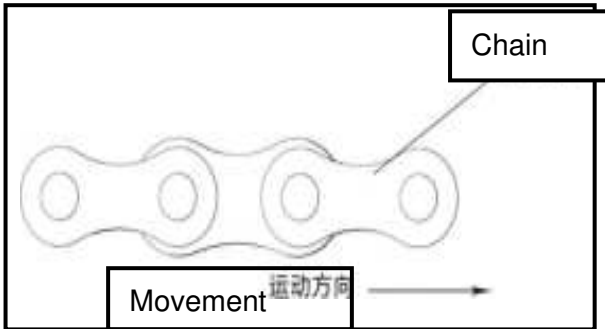

The open end of the chain spring should be opposite to the chain movement direction

#### Saddle adjustment:

1. Pull the saddle to check whether the saddle is loose or skewed.
2. When adjusting the height of the saddle, pay attention to minimum and maximum insert length.
3. Always tighten the saddle clamp after adjustment, and check the saddle before each ride.

#### Brake adjustment

1. Check the condition of your brake regularly. To check, while ride normally, hold front then rear brakes at different times. The rear wheels will lock the motion of bike and the front wheels will quickly slow down and the bicycle will tip forward.
2. Adjust the distance between the brake pads and the rim to adjust braking effect. Please consult professional servicing provider if unsure.
3. Replace the brake pads if they are severely worn (more than 2/3), always replace the left and right brake pads together at the same time.
4. After adjusting the brake, be sure to tighten the brake wire fixing screws
5. Rubber brake pads should not be contaminated with any grease. If they are contaminated with grease, their braking performance will be greatly reduced, and they must be replaced.

6. Disc brakes can produce a very high braking force. Sudden brake when riding with speed can cause the whole bike to topple. Practice braking until you gainfull control of the bicycle.
7. Improper use of the additional shock-absorbing elements in the brake system (power regulator) can cause serious accidents. The specified spring force of thepower regulator depends on the total weight of the bicycle

Adjustment and maintenance:

It is recommended to conduct a comprehensive inspection and maintenance of thebike after the initial 300 kilometers of riding. After that, carry out a more comprehensive inspection of the bike for every 1,000 kilometers of riding.

Lubrication:

Appropriately lubricate the parts that need lubrication, such as chains, brake lines,and bike supports.

DO NOT lubricate Rim surface, brake pad surface, tire surface, electrical switch

Recommended tightening torque of fasteners

Parts	Specifications	Torque (N.m)
Crank arm	M8	30
Pedals	9/16 of an inch	30
Axle, Front	general	25
Axle, Rear	general	30
Stem wedge bolt	M8	23
Stem, fork end fixture	M5/M6/M7	M5:5/ M6:10/ M7:14
Stem, direction fixation device	M5/M6/M7	M5:5/ M6:10/ M7:14
Rod end, outer band	M5/M6	M5:5/ M6:10
Seat post, hoop	M8/M6	M8:20/ M6:10
Seat post clamp	M7/M8	M7:14/ M8:20
Brake pad	M6	10
Brake cable clamp	M6	10
Brake handle clamp	M5	5
V-type brakes, fastening screws	M6	10
Flywheel fastens screw	None	40
Flywheel, lock ring	None	30

\*The above values are only reference values, please follow the attached partsmanufacturer's operating instructions

## 9. Technical Parameters

MODEL	Bravo
Dimensions(L*W*H)	1890*700*1140mm
Wheelbase	1150mm
Weight	25kg
Max Speed	25km/h
Recharge Mileage	90km
100 km power consumption	0.58 (kw h) /100km
Deadweight	105kg + 25kg
Type of Batter	lithium battery
Battery Capacity	14.5Ah
Motor type	Center Motor
Rated Power	250W
Rated Speed	120r/min
Rated Voltage	36V
Controller undervoltage protection value	31±0.5V
Controller overcurrent protection value	15±0.5A

## 10. Legal documentation

### 10.1 Service and warranty

Dear user: Thank you for using the electric bicycle produced by our company. To protect your safety and rights, please keep the manual properly.

#### Maintenance and precautions:

- 1) Only use original parts purchased from manufacturer, authorized resellers, bike service provider.  
The manufacturer will not be responsible for any loss or injuries caused by using a third-party part.
- 2) It is recommended to go to the dealer or service station for a battery maintenance after 3 months.
- 3) The user should not accelerate rapidly during driving, and try to avoid sudden brakes.
- 4) Please do not modify the bike body, cables, electrical components, and the structure and function of the bike without permission; unauthorized changes to the parameters of cables and electrical components will cause deterioration of handling performance, increased noise, failure of electrical performance and other situations Occurs, resulting in the shortening of the life of the bike, causing safety hazards, and the performance cannot be effectively guaranteed; the resulting liability losses; the company is not responsible, and the user will be responsible for it.

#### 10.2 Warranty conditions

This warranty covers any defects in material or workmanship under normal use during the "Warranty Period".

Warranty does not cover tires, tubes, brake pads or chains.

This Limited Product Warranty does not apply under the following circumstances:

1. Damage caused by operating the product outside the permitted or intended uses described by the manufacturer's instructions
2. Damage caused by incorrect operations, such as negligent, improper maintenance or incorrect use of the product.
3. Operation of the vehicle when it is overheating
4. Commercial use of the product, such as rental.

5. The products are damaged, misused, or tampered with from the original state it was delivered.
6. Unauthorised modifications to any part of the product, including but not restricted to:
  - a. Modification to controller
  - b. Modification to battery
  - c. Modification to motor
  - d. Modification to charger
  - e. Modification to throttle
  - f. Modification to power system
  - g. Modification to suspension
  - h. Modification to brakes
7. The battery is un-sealed.
8. Installing performance parts or components on the vehicle that change the original engineering.
9. Damage caused by servicing of the product (including upgrades and expansions) performed by anyone who is not authorised by Panmi/ Benelli to perform such services
10. Damage caused by nature or acts of God, for example, lightning strikes, cyclones, and the like.
11. Damage caused by natural wear and tear.

**Disclaimer:**

Do not tamper with your bicycle. Tampering is removing or replacing any original equipment or modifying your bicycle in anyway that may change its design and/or operation. Such changes may seriously impair the handling, stability and other aspects of the bicycle, making it unsafe to ride. Tampering can void the warranty and render your bike not in compliance with the applicable laws and regulations. To ensure safety, quality and reliability, use only original parts or Benelli authorized replacements for repair and replacement. Benelli is not responsible for any direct, incidental or consequential damages, including, without limitation, damages for personal injury, property damage, or economic losses due to tampering.



## 11. Fault and troubleshooting

### Error indication

The display shows an error code for the failures. When a failure is detected, the LCD screen displays an icon, and the error code at the bottom.

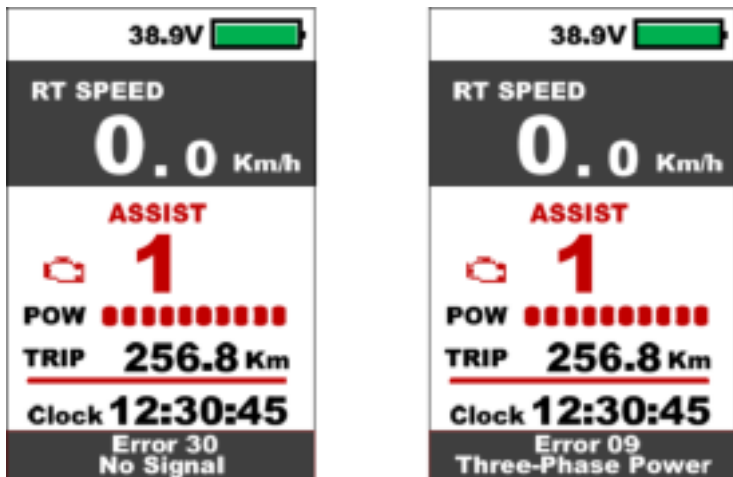

The error code table is as follows !

NO	Status data	Error code meaning
3	0x04	Shifter lever did not return (stopped at high position)
4	0x05	Shift lever failure
6	0x07	Overvoltage protection
7	0x08	Motor Hall signal wire failure
8	0x09	Motor phase line failure
9	0x10	The controller temperature is high and reaches the protection point
10	0x11	Controller temperature sensor failure
11	0x12	Current sensor failure
12	0x13	Temperature failure in the battery
13	0x14	The temperature sensor in the motor is faulty
13	0x21	Speed sensor failure
14	0x22	BMS
15	0x23	Headlight failure
16	0x24	Headlight sensor failure
17	0x25	Torque sensor torque signal failure
18	0x26	Torque sensor speed failure
19	0x30	Communication failure

## Troubleshooting

NO	The fault phenomenon	The cause of the problem	Elimination method
1	The motor hub does not work after the power is switched on	Battery wiring is loose ; Motor fault; Electrical cable failure;	Repair and reconnection; Professional repair or replacement; Find a professional repair or repair shop
2	Short range on a single charge	Insufficient tire pressure; Insufficient charging or charger failure; Battery aging or damage;More uphill, strong headwind, frequent brakestart, load big	Sufficient air; Sufficient electricity or check whether the charger plug is in bad contact: Find a professional repair or repair shop. It is recommended to use a human foot assist in these cases .
3	Charger not charging	The charger socket fallsoff or the plug is disconnected from the socket The internal fuse of the charger is blown out Battery wiring comes off.	Tighten socket box connectors; Replace the fuse; Welding line
4	Other fault	When you encounter any problem that cannot be excluded by yourself under the above instructions Obstacles or undetermined faults; Motor hub, controller, charger and battery pack are damaged at the right time.	In case of any of the above, please contact the supplier or maintenance station. Do not open the above parts without authorization, or you will lose our warranty commitment.



## 12. Front Fender Installation

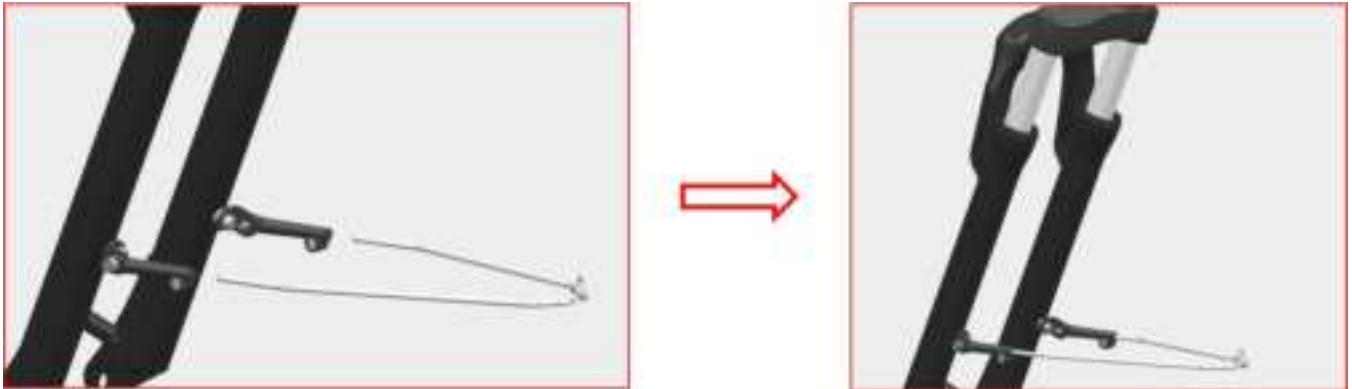

1. Insert the front end of the front fender strut into the black adjuster (make sure the adjuster is locked)



2. Insert bolt through the flat washer, headlight bracket and the front fender mount respectively and pre-lock onto the suspension fork brace . Fix the nuts on the back of the front fork. (Loosely screw this together, should not be locked tight at this stage)

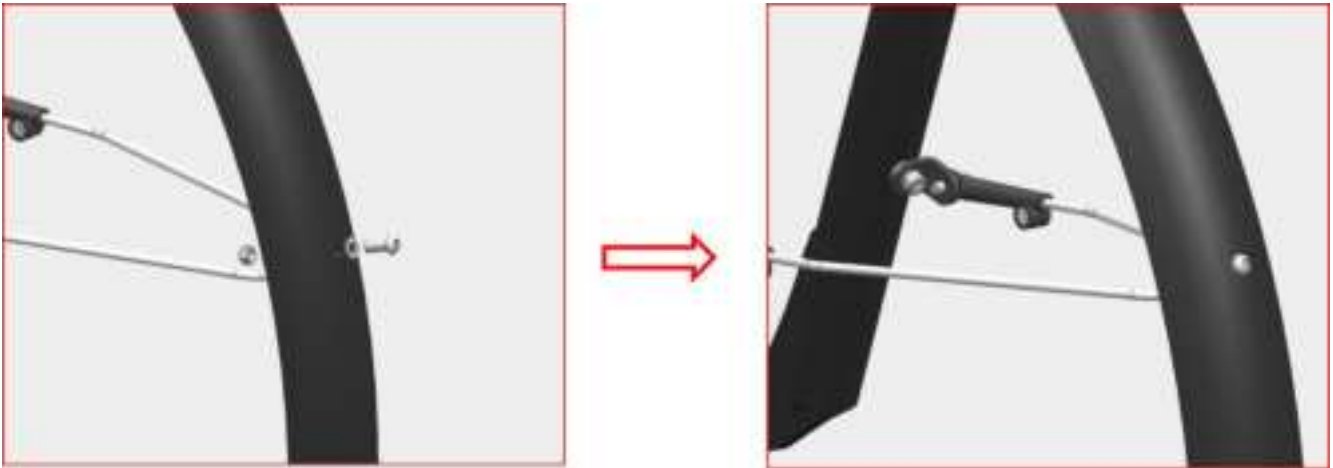

3. To connect to the fender strut, the bolts is passed through the flat washer, the tail hole of the front fender, hole of the front fender strut and then fastened with the nut (4 — 6 N.m).
4. Install the front wheel and adjust the clearance between the front fender and the front tyre to 15-20mm.



Lock the front fender support adjuster, tighten the screws to (4-6N.m)



and suspension fork brace tighten the bolt to (6-10N.m).



