



Operator's Manual

Serial Number Range

S-60 HC

after S6006-13800

**CE
Australia
ANSI (except US and Canada)**

**with
Maintenance
Information**

**First Edition
Second Printing
Part No. 114303**

Important

Read, understand and obey these safety rules and operating instructions before operating this machine. Only trained and authorized personnel shall be permitted to operate this machine. This manual should be considered a permanent part of your machine and should remain with the machine at all times. If you have any questions, call Genie Industries.

Contents

	Page
Introduction	1
Symbol and Hazard Pictorials Definitions	3
General Safety	5
Personal Safety	11
Work Area Safety	12
Legend	18
Controls	19
Inspections	26
Operating Instructions	38
Transport and Lifting Instructions	44
Maintenance	47
Specifications	51

Contact us:

Internet: www.genielift.com
E-mail: techpub@genieind.com

Copyright © 2006 by Genie Industries

First Edition: Second Printing, May 2008

"Genie" is a registered trademark of Genie Industries in the U.S.A. and many other countries. "S" is a trademark of Genie Industries.

These machines comply with ANSI/SIA 92.5-2006.

 Printed on recycled paper

Printed in U.S.A.

Introduction

Owners, Users and Operators:

Genie appreciates your choice of our machine for your application. Our number one priority is user safety, which is best achieved by our joint efforts. We feel that you make a major contribution to safety if you, as the equipment users and operators:

- 1 Comply** with employer, job site and governmental rules.
- 2 Read, understand and follow** the instructions in this and other manuals supplied with this machine.
- 3 Use good safe work practices** in a commonsense way.
- 4 Only have trained/certified operators**, directed by informed and knowledgeable supervision, running the machine.

If there is anything in this manual that is not clear or which you believe should be added, please contact us.

Internet: www.genielift.com

E-mail: techpub@genieind.com



Danger

Failure to obey the instructions and safety rules in this manual will result in death or serious injury.

Do Not Operate Unless:

- You learn and practice the principles of safe machine operation contained in this operator's manual.

1 Avoid hazardous situations.

Know and understand the safety rules before going on to the next section.

- 2 Always perform a pre-operation inspection.
- 3 Always perform function tests prior to use.
- 4 Inspect the workplace.
- 5 Only use the machine as it was intended.

- You read, understand and obey the manufacturer's instructions and safety rules—safety and operator's manuals and machine decals.
- You read, understand and obey employer's safety rules and worksite regulations.
- You read, understand and obey all applicable governmental regulations.
- You are properly trained to safely operate the machine.

Introduction

Hazard Classification

Genie uses symbols, color coding and signal words to identify the following:



Safety alert symbol—used to alert personnel to potential personal injury hazards. Obey all safety messages that follow this symbol to avoid possible injury or death.

▲ DANGER

Red

Indicates an imminently hazardous situation which, if not avoided, will result in death or serious injury.

▲ WARNING

Orange

Indicates a potentially hazardous situation which, if not avoided, could result in death or serious injury.

▲ CAUTION

Yellow

Indicates a potentially hazardous situation which, if not avoided, may cause minor or moderate injury.

NOTICE

Blue

Indicates a potentially hazardous situation which, if not avoided, may result in property damage.

Intended Use

This machine is intended to be used only to lift personnel, along with their tools and materials to an aerial work site.





Safety Sign Maintenance

Replace any missing or damaged safety signs. Keep operator safety in mind at all times. Use mild soap and water to clean safety signs. Do not use solvent-based cleaners because they may damage the safety sign material.

Symbol and Hazard Pictorials Definitions

 <p>Crush Hazard</p>	 <p>Explosion Hazard</p>	 <p>Fire Hazard</p>	 <p>Explosion Hazard</p>	 <p>Electrocution Hazard</p>
 <p>Fall Hazard</p>	 <p>Crush Hazard</p>	 <p>Tip-over Hazard</p>	 <p>Tip-over Hazard</p>	 <p>Tip-over Hazard</p>
 <p>Tip-over Hazard</p>	 <p>Tip-over Hazard</p>	 <p>Electrocution Hazard</p>	 <p>Maximum Manual Force</p>	 <p>Maximum Wind Speed</p>
 <p>Keep off this surface.</p>	 <p>Keep away from moving parts.</p>	 <p>Maintain required clearance.</p>	 <p>Keep away from path of moving platform.</p>	 <p>Only trained maintenance personnel should access compartments.</p>
 <p>Read the operator's manual.</p>	 <p>No smoking. No flame. Stop engine.</p>	 <p>Counterweight uphill: 1 Retract boom. 2 Lower boom.</p>	 <p>Counterweight downhill: 1 Lower boom. 2 Retract boom.</p>	 <p>Do not use ether or other high energy starting aids on machines equipped with glow plugs.</p>

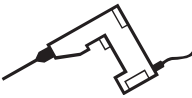
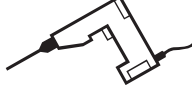
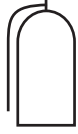
Symbol and Hazard Pictorials Definitions

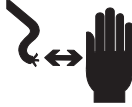
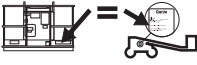
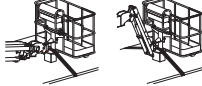
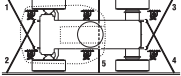
 <p>Lanyard attachment point</p>	 <p>Wheelload</p>	 <p>Voltage rating for power to platform</p>	 <p>Pressure rating for air line to platform</p>	 <p>Have fire extinguisher near.</p>
 <p>Replace tires with same tire.</p>	 <p>Avoid contact.</p>	 <p>Replace platform with same rated platform.</p>	 <p>Tie-down instructions</p>	 <p>Tie-down instructions</p>

General Safety

Safety signs and locations

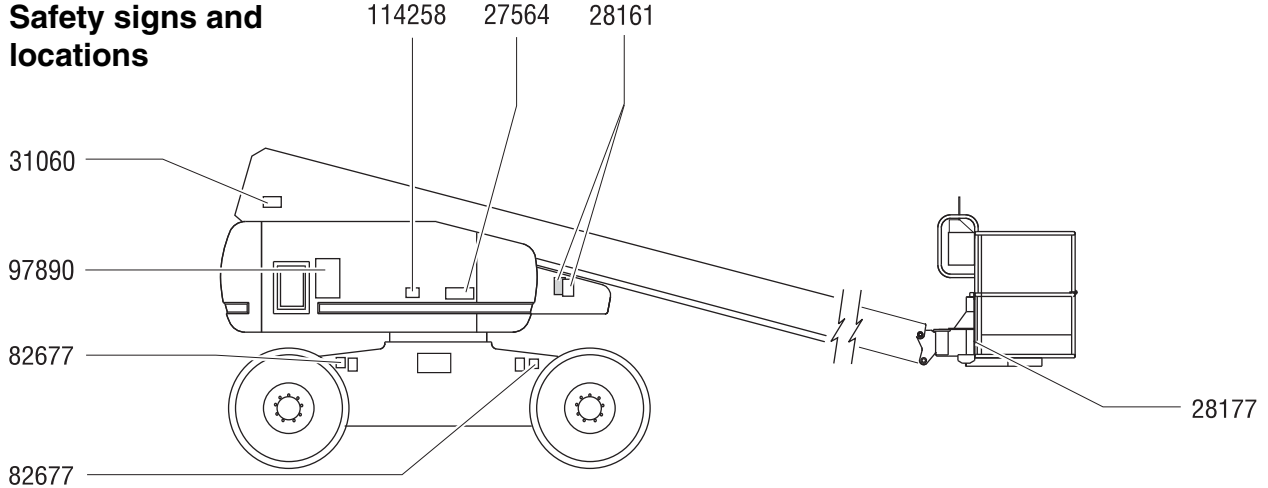

82677

⚠ DANGER

Tip-over Hazard
Failure to replace tires with tires of same specification will result in death or serious injury.

Tires are critical to machine stability.
Do not replace factory-installed tires with high flotation tires.
Only replace factory-installed tires with tires of same specification and ply rating. Tire Size 355/55 D625, 14 ply

Tire Pressure:
70 psi / 4.92 bar

Lug Nut Torque:
Dry bolts:
170 ft-lbs / 225 Nm
Lubricated bolts:
130 ft-lbs / 176 Nm

82677 C

28177

⚠ WARNING

Crush Hazard
Death or serious injury may result from platform crushing personnel against boom.

Keep away from path of moving platform.

28177 C

97890

⚠ DANGER

Failure to read, understand and obey the operator's manual and the following safety rules will result in death or serious injury.

Improper Use Hazard
The operator is responsible for safe machine operation. This includes:
- Avoid hazardous situations.
- Always perform a pre-operation inspection.
- Always perform function tests prior to use.
- Inspect work blocks.
- Only use the machine as it was intended.
Do not operate unless:
- You read, understand and obey:
 - manufacturer's instructions and safety rules — safety and operator's manuals and decals
 - employer's safety rules
 - applicable governmental regulations
You are properly trained to safely operate this machine.

Electrocution Hazards
This machine is not electrically insulated and will not provide protection from contact with or proximity to electrical current.

Minimum Safe Approach Distance	Voltage	Required Clearance
15 ft (4.57 m)	0 to 300V	Avoid Contact
20 ft (6.10 m)	300V to 50KV	10 ft / 3.05 m
25 ft (7.62 m)	50KV to 200KV	15 ft / 4.60 m
35 ft (10.67 m)	200KV to 350KV	20 ft / 6.10 m
45 ft (13.72 m)	350KV to 500KV	25 ft / 7.62 m
	500KV to 750KV	35 ft / 10.67 m
	750KV to 1000KV	45 ft / 13.72 m

Do not alter or disable machine components that in any way affect safety and stability.
Do not push off or pull toward any object outside of the machine.
Do not place or attach overhanging loads to any part of this machine.
Do not place ladders or scaffolds in platform or against any part of this machine.

Fall Hazards
Occupants must wear a safety belt or harness in accordance with governmental regulations. Attach lanyard to anchor provided in platform.
Do not sit, stand or climb on the platform guard rails.
Do not climb down from the platform when raised.
Lower the platform any time you exit the entry gate before operating.

Collision Hazards
Be aware of limited sight distance and blind spots when driving or operating.
Check work area for overhead obstructions or other possible hazards.
Be aware of crushing hazard when grasping the platform guard rail.
Observe and use color-coded direction arrows on the platform control and drive controls for drive and steer functions.
Do not lower the boom unless the area below is clear of personnel and obstructions.

Explosion Hazard
Do not start engine if you smell or detect liquid petroleum gas (LPG), gasoline, diesel fuel or other flammable substances.
Do not refuel the machine with the engine running.

Damaged Machine Hazards
Do not use a damaged or malfunctioning machine.
Be sure all maintenance has been performed as specified in the appropriate operator's and service manuals.
Be sure all decals are in place and legible.
Be sure safety, operator's and responsibility manuals are complete, legible and in the storage container located on the platform.

97890 A

27564

⚠ DANGER

Electrocution Hazard
Death or injury can result from contacting electric power lines.

Always contact the electric power line owner. The electric power shall be disconnected or the power lines moved or insulated before machine operations begin.

27564 C

Maintain required clearance.

Line Voltage	Required Clearance
0 to 300V	Avoid Contact
300V to 50KV	10 ft / 3.05 m
50KV to 200KV	15 ft / 4.60 m
200KV to 350KV	20 ft / 6.10 m
350KV to 500KV	25 ft / 7.62 m
500KV to 750KV	35 ft / 10.67 m
750KV to 1000KV	45 ft / 13.72 m

28161

⚠ WARNING

Crush Hazard
Contact with moving parts can result in death or serious injury.

Keep away from moving parts.

28161 C

114258

⚠ DANGER

Burn Hazard
Fuel and fumes can explode and burn.

No smoking. No flame. Stop engine.

114258 A

31060

⚠ DANGER

Tip-over Hazard
Altering or disabling limit switches can result in machine tip-over. Machine tip-over will result in death or serious injury.

Do not alter or disable limit switch(es).

31060 B

General Safety

Safety signs and locations

33952

1000262

114269

⚠ DANGER	
	Counterweight downhill: 1 Lower boom. 2 Retract boom.
Tip-over Hazard If tilt-alarm sounds, unit is on a severe slope. Death or serious injury could occur. 33952 B	
	Counterweight uphill: 1 Retract boom. 2 Lower boom.

⚠ DANGER
Tip-over Hazard Failure to match rated loads could result in an overloaded platform, which could result in machine tipping over.
When replacing platform, be sure rated load on replacement platform matches rated load on machine serial number label.
Do not attach this platform to a machine with any other rated load. 1000262 B

⚠ DANGER
Tip-over Hazard Welder power supply reduces rated platform capacity and must be factored into total platform load.
Do not overload platform. Welder power supply weighs 75 lbs / 34 kg. 114269 A

97890

⚠ DANGER
Failure to read, understand and obey the operator's manual and the following safety rules will result in death or serious injury.
Improper Use Hazard The operator is responsible for safe machine operation. This includes: 1 Avoid hazardous situations. 2 Always perform a pre-operation inspection. 3 Always perform function tests prior to use. 4 Inspect work place. 5 Only use the machine as it was intended. Do not operate unless: You read, understand and obey: - manufacturer's instructions and safety rules — safety and operator's manuals and decals - employer's safety rules - applicable governmental regulations You are properly trained to safely operate this machine.
Electrocution Hazards This machine is not electrically insulated and will provide protection from contact with or proximity to electrical current.
Tip-over Hazards Do not raise or extend boom unless machine is on firm level ground. Do not depend on tilt alarm as a level indicator. Tilt alarm sounds in platform only when machine is on a severe slope. Do not raise boom when wind speeds may exceed 28 mph / 12.5 m/s. Do not operate machine in strong or gusty winds. Do not increase surface area of platform or load, increasing area exposed to wind will decrease machine stability. Do not drive machine on or near uneven terrain, unstable surfaces or other hazardous conditions with boom raised or extended. Do not drive machine on a slope that exceeds the maximum slope or side slope rating for the machine. Use extreme care and slow speeds while driving the machine in stowed position across uneven terrain, dunes, unstable or slippery surfaces and near ruts and drop-offs. Do not attempt to hoist or snagged platform using platform controls. All personnel must be removed from platform before attempting to free platform using ground controls.
Collision Hazards Be aware of limited sight distance and blind spots when driving or operating. Check work area for overhead obstructions or other possible hazards. Be aware of crushing hazard when grasping the platform guard rail. Choose and use on/off-coded direction arrows on the platform controls and drive controls for drive and steer functions. Do not lower the boom unless the area below is clear of personnel and obstructions. Explosion Hazard Do not start engine if you smell or detect liquid petroleum gas (LPG), gasoline, diesel fuel or other explosive substances. Do not refuel the machine with the engine running. Damaged Machine Hazards Do not use a damaged or malfunctioning machine. Be sure all maintenance has been performed as specified in the appropriate operator's and service manual. Be sure all details are in place and tight. Be sure safety, operator's and responsibilities manuals are complete, legible and in the storage compartment located on the platform.

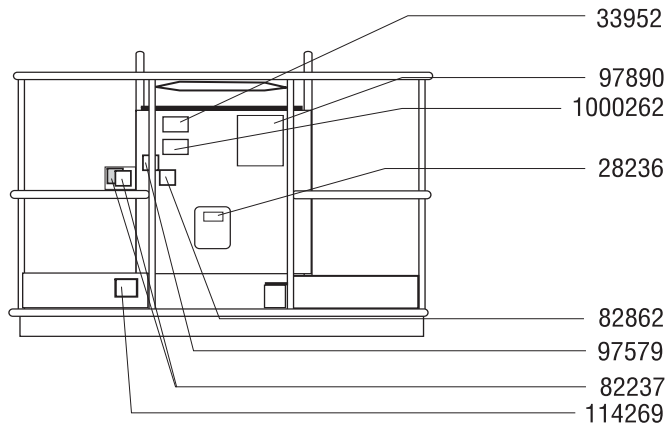

82862

28236

⚠ DANGER
Fire Hazard Serious injury or death will result if fire occurs while operating welder and fire extinguisher is not available.
Do not operate welder unless fire extinguisher is immediately available for instant use, per OSHA regulation 1926.352(d). 97579 C

⚠ WARNING	
Improper operation or maintenance can result in serious injury or death.	
	Read and understand Operator's Manual, Responsibilities Manual and Safety Manual and all safety signs before using or maintaining machine. If you do not understand the information in the manuals, consult your supervisor, the owner or the manufacturer. 28236 D

82237

⚠ DANGER
Electrocution Hazard Contact with energized components can result in death or serious injury.
Avoid contact with energized components. 82237 B

General Safety

Safety signs and locations

27564

⚠ DANGER



Electrocution Hazard
Death or injury can result from contacting electric power lines.

Always contact the electric power line owner. The electric power shall be disconnected or the power lines moved or insulated before machine operations begin.

Maintain required clearance.		
Line Voltage	Required Clearance	Avoid Contact
0 to 300V	10 ft / 3.05 m	
300V to 500KV	15 ft / 4.60 m	
500KV to 200KV	20 ft / 6.10 m	
200KV to 350KV	25 ft / 7.62 m	
350KV to 500KV	35 ft / 10.67 m	
500KV to 750KV	45 ft / 13.72 m	

28175

⚠ WARNING



Compartment access is restricted.
Contact with components under any cover may result in serious injury.



Only trained maintenance personnel should access compartments. Access by operator is only advised when performing Pre-operation Inspection. All compartments must remain closed and secured during operation.

28177

⚠ WARNING



Crush Hazard
Death or serious injury may result from platform crushing personnel against boom.



Keep away from path of moving platform.

82677

⚠ DANGER



Tip-over Hazard
Failure to replace tires with tires of same specification will result in death or serious injury.



Tires are critical to machine stability.
Do not replace factory-installed tires with high flotation tires.



Only replace factory-installed tires with tires of same specification and ply rating. Tire Size: 355/55 D625, 14 ply

Tire Pressure:
70 psi / 4.92 bar

Lug Nut Torque:
Dry bolts:
170 ft-lbs / 225 Nm
Lubricated bolts:
130 ft-lbs / 176 Nm

28161

⚠ WARNING



Crush Hazard
Contact with moving parts can result in death or serious injury.



Keep away from moving parts.

28181

⚠ WARNING



Fall Hazard
Death or serious injury may result from climbing or riding on boom.



Keep off this surface.

31060

⚠ DANGER



Tip-over Hazard
Altering or disabling limit switches can result in machine tip-over. Machine tip-over will result in death or serious injury.



Do not alter or disable limit switch(s).

97602

⚠ WARNING



Explosion Hazard
Death or serious injury can result from the use of ether or other high energy starting aids.

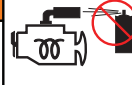

Do not use ether or other high energy starting aids on machines equipped with glow plugs.

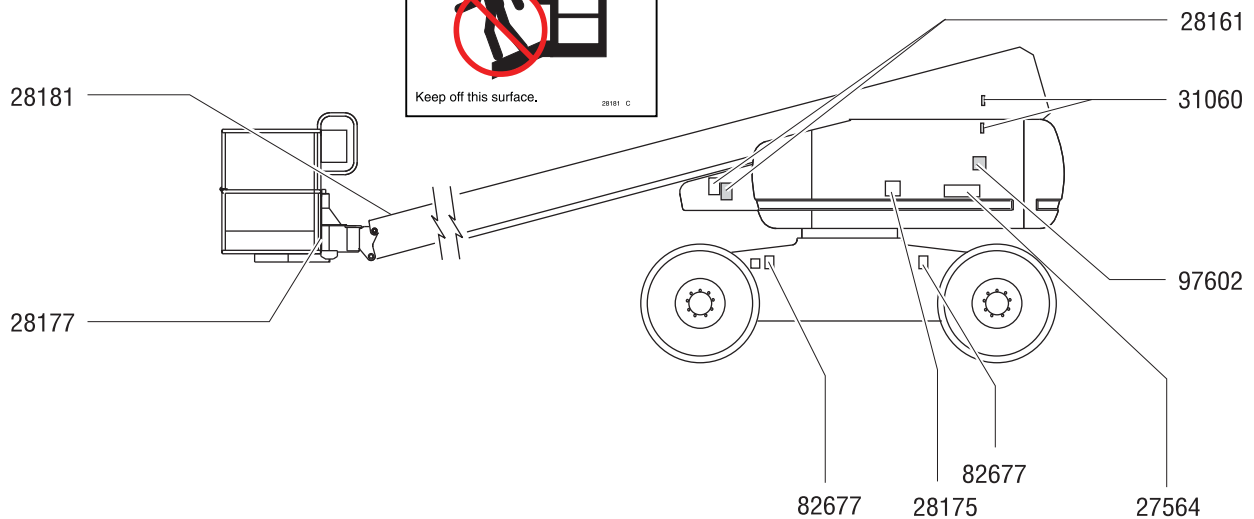

General Safety

Safety signs and locations

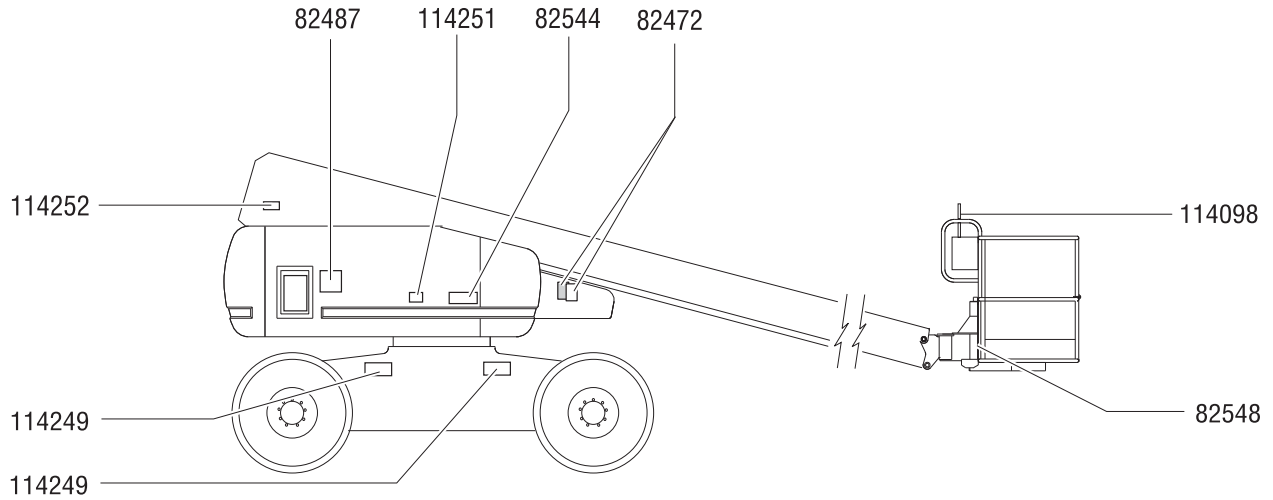

114249

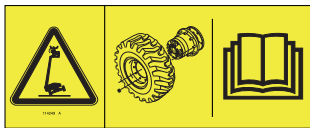

114252



82487



114251



82544



82472



114098

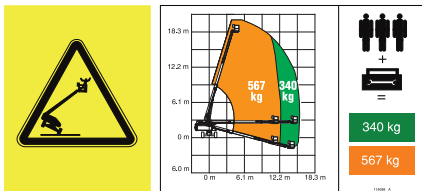

82548



General Safety

Safety signs and locations

82487



114248



114098

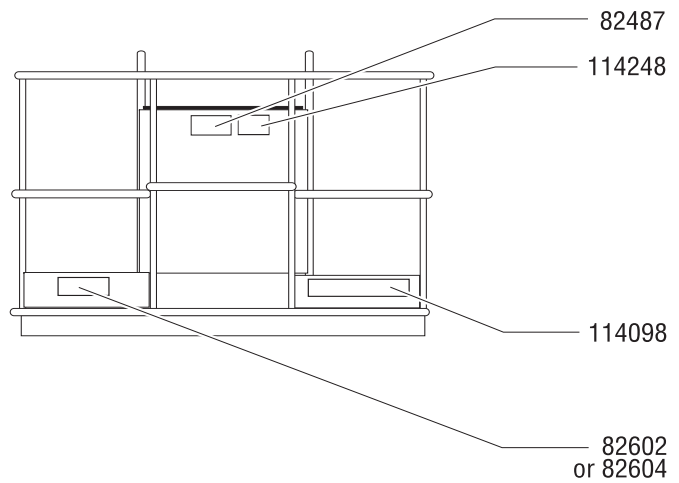
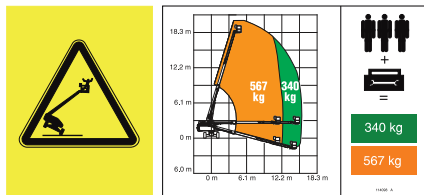

82602

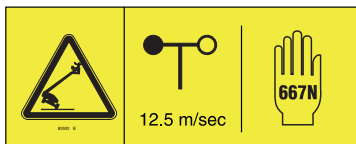

82604

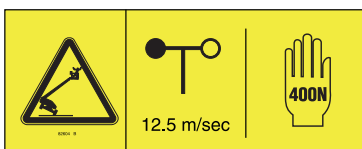

General Safety

Safety signs and locations

114247



82671



82548



82472



114249

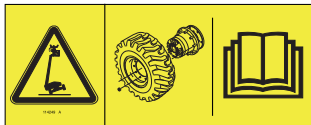

82544



82473

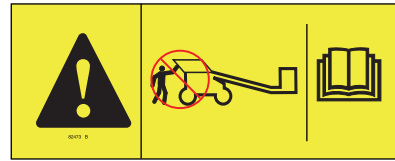

114252

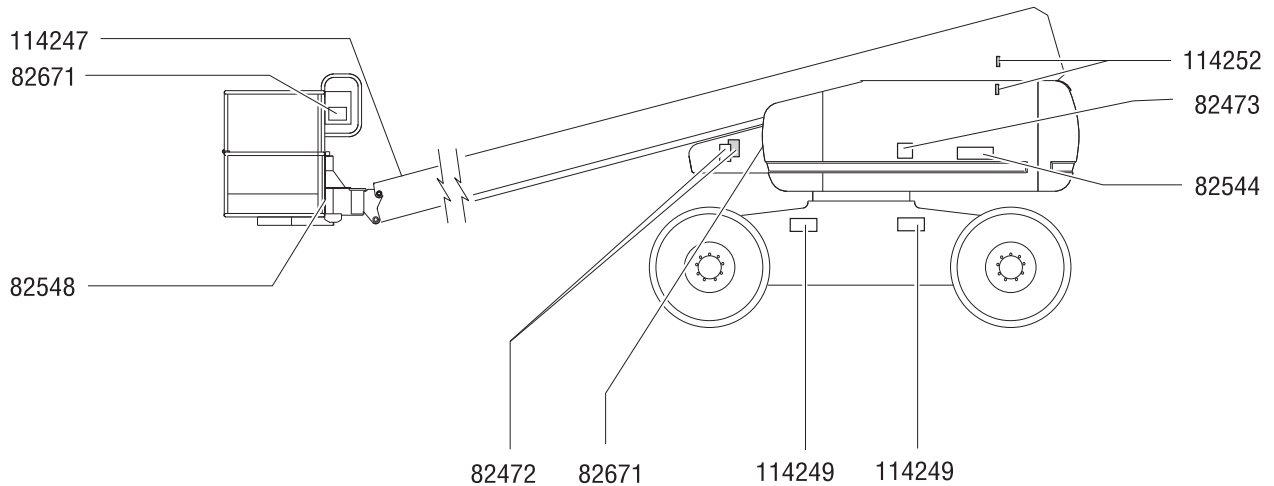

Personal Safety

Fall Protection

Personal fall protection equipment (PFPE) is required when operating this machine.

Occupants must wear a safety belt or harness in accordance with governmental regulations. Attach the lanyard to the anchor provided in the platform.

Operators must comply with employer, job site and governmental rules regarding the use of personal protective equipment.

All PFPE must comply with applicable governmental regulations, and must be inspected and used in accordance with the PFPE manufacturer's instructions.

Work Area Safety

⚠️ Electrocuting Hazards

This machine is not electrically insulated and will not provide protection from contact with or proximity to electrical current.

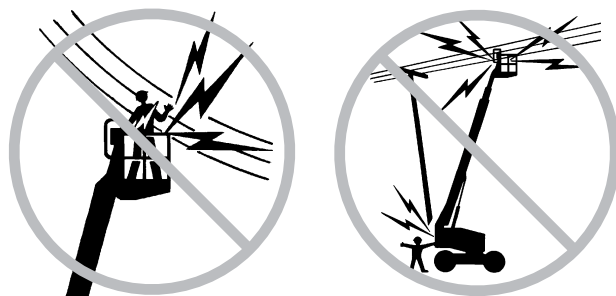

Maintain safe distances from electrical power lines and apparatus in accordance with applicable governmental regulations and the following chart.

Voltage Phase to Phase	Minimum Safe Approach Distance	
	Feet	Meters
0 to 300V	Avoid Contact	
300V to 50KV	10	3.05
50KV to 200KV	15	4.60
200KV to 350KV	20	6.10
350KV to 500KV	25	7.62
500KV to 750KV	35	10.67
750KV to 1000KV	45	13.72

Allow for platform movement, electrical line sway or sag and beware of strong or gusty winds.

Keep away from the machine if it contacts energized power lines. Personnel on the ground or in the platform must not touch or operate the machine until energized power lines are shut off.

Do not operate the machine during lightning or storms.

Do not use the machine as a ground for welding.

⚠️ Tip-over Hazards

Occupants, equipment and materials shall not exceed the maximum platform capacity for the restricted or unrestricted range of motion.

Maximum platform capacity

Unrestricted range of motion	750 lbs	340 kg
Restricted range of motion	1250 lbs	567 kg

Maximum occupants

3

S-60 High Capacity Boom: Do not attach a platform rated at 750 lbs / 340 kg (unrestricted range of motion) and 1250 lbs / 567 kg (restricted range of motion) to machines with any other rated load. See the serial label for the maximum rated load.

The weight of options and accessories, such as pipe cradles, panel cradles and welders, will reduce the rated platform capacity and must be factored into the total platform load. See the decals with the options and accessories.

If using accessories, read, understand and obey the decals and instructions with the accessory.

Work Area Safety

Do not raise or extend the boom unless the machine is on a firm, level surface.

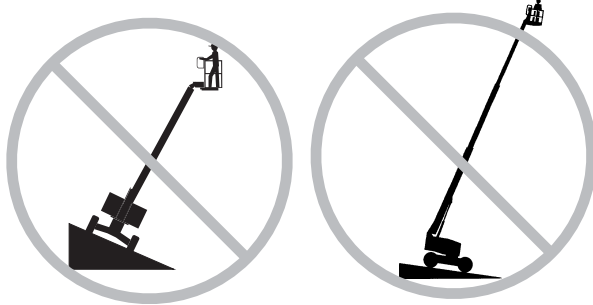

Do not depend on the tilt alarm as a level indicator. The tilt alarm sounds in the platform only when the machine is on a severe slope.

If the tilt alarm sounds:

Do not extend, rotate or raise the boom above horizontal. Move the machine to a firm, level surface before raising the platform. If the tilt alarm sounds when the platform is raised, use extreme caution to retract the boom and lower the platform. Do not rotate the boom while lowering. Move the machine to a firm, level surface before raising the platform.

If the tilt alarm sounds with the counterweight downhill:
First lower the boom, then retract the boom.



If the tilt alarm sounds with the counterweight uphill:
First retract the boom, then lower the boom.

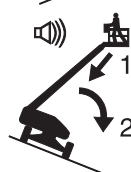

Do not raise the boom when wind speeds may exceed 28 mph / 12.5 m/s. If wind speeds exceed 28 mph / 12.5 m/s when the boom is raised, lower the boom and do not continue to operate the machine.

Do not operate the machine in strong or gusty winds. Do not increase the surface area of the platform or the load. Increasing the area exposed to the wind will decrease machine stability.



Use extreme care and slow speeds while driving the machine in the stowed position across uneven terrain, debris, unstable or slippery surfaces and near holes and drop-offs.

Do not drive the machine on or near uneven terrain, unstable surfaces or other hazardous conditions with the boom raised or extended.

Do not use the machine as a crane.

Do not push the machine or other objects with the boom.

Do not contact adjacent structures with the boom.

Do not tie the boom or platform to adjacent structures.

Do not place loads outside the platform perimeter.

Work Area Safety

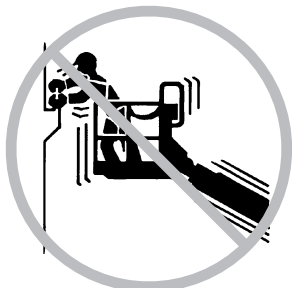

Do not push off or pull toward any object outside of the platform.

Maximum allowable side force - ANSI
150 lbs / 667 N

Maximum allowable manual force - CE and Australia 90 lbs / 400 N

Do not alter or disable machine components that in any way affect safety and stability.

Do not replace items critical to machine stability with items of different weight or specification.

Do not replace factory-installed tires with tires of different specification or ply rating.

Do not modify or alter an aerial work platform without prior written permission from the manufacturer. Mounting attachments for holding tools or other materials onto the platform, toeboards or guard rail system can increase the weight in the platform and the surface area of the platform or the load.

Do not place or attach overhanging loads to any part of this machine.



Do not place ladders or scaffolds in the platform or against any part of this machine.

Do not transport tools and materials unless they are evenly distributed and can be safely handled by person(s) in the platform.

Do not use the machine on a moving or mobile surface or vehicle.

Be sure all tires are in good condition, air-filled tires are properly inflated and lug nuts are properly tightened.

Do not use the platform controls to free a platform that is caught, snagged or otherwise prevented from normal motion by an adjacent structure. All personnel must be removed from the platform before attempting to free the platform using the ground controls.

⚠ Operation on Slopes Hazards

Do not drive the machine on a slope that exceeds the maximum uphill, downhill or side slope rating of the machine. Slope rating applies only to machines in the stowed position.

Maximum slope rating, stowed position, 2WD

Counterweight uphill	30% (17°)
Counterweight downhill	10% (6°)
Side slope	25% (14°)

Maximum slope rating, stowed position, 4WD

Counterweight uphill	45% (24°)
Counterweight downhill	30% (17°)
Side slope	25% (14°)

Note: Slope rating is subject to ground conditions and adequate traction.

Work Area Safety

⚠ Fall Hazards



Occupants must wear a safety belt or harness in accordance with governmental regulations. Attach the lanyard to the anchor provided in the platform.

Do not sit, stand or climb on the platform guard rails. Maintain a firm footing on the platform floor at all times.



Do not climb down from the platform when raised.

Keep the platform floor clear of debris.

Lower the platform entry mid-rail or close the entry gate before operating.

⚠ Collision Hazards

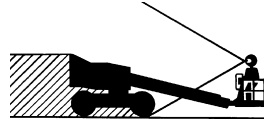

Be aware of limited sight distance and blind spots when driving or operating.

Be aware of the boom position and tailswing when rotating the turntable.

Check the work area for overhead obstructions or other possible hazards.



Be aware of crushing hazards when grasping the platform guard rail.

Operators must comply with employer, job site and governmental rules regarding the use of personal protective equipment.

Observe and use the color-coded direction arrows on the platform controls and drive chassis for drive and steer functions.

Work Area Safety

Do not lower the boom unless the area below is clear of personnel and obstructions.

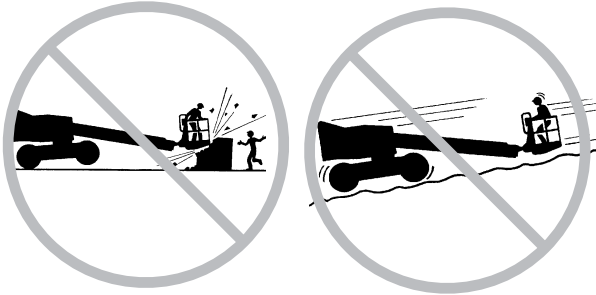

Limit travel speed according to the condition of the ground surface, congestion, slope, location of personnel, and any other factors which may cause collision.

Do not operate a boom in the path of any crane unless the controls of the crane have been locked out and/or precautions have been taken to prevent any potential collision.

No stunt driving or horseplay while operating a machine.

⚠ Bodily Injury Hazard

Do not operate the machine with a hydraulic oil or air leak. An air leak or hydraulic leak can penetrate and/or burn skin.

Always operate the machine in a well-ventilated area to avoid carbon monoxide poisoning.

Improper contact with components under any cover will cause serious injury. Only trained maintenance personnel should access compartments. Access by the operator is only advised when performing a pre-operation inspection. All compartments must remain closed and secured during operation.

⚠ Explosion and Fire Hazards

Do not start the engine if you smell or detect liquid petroleum gas (LPG), gasoline, diesel fuel or other explosive substances.

Do not refuel the machine with the engine running.

Refuel the machine and charge the battery only in an open, well-ventilated area away from sparks, flames and lighted tobacco.

Do not operate the machine in hazardous locations or locations where potentially flammable or explosive gases or particles may be present.

Do not spray ether into engines equipped with glow plugs.

⚠ Damaged Machine Hazards

Do not use a damaged or malfunctioning machine.

Conduct a thorough pre-operation inspection of the machine and test all functions before each work shift. Immediately tag and remove from service a damaged or malfunctioning machine.

Be sure all maintenance has been performed as specified in this manual and the appropriate Genie service manual.

Be sure all decals are in place and legible.

Be sure the operator's, safety and responsibilities manuals are complete, legible and in the storage container located on the platform.

⚠ Component Damage Hazards

Do not use any battery or charger greater than 12V to jump-start the engine.

Do not use the machine as a ground for welding.

Work Area Safety

⚠ Battery Safety

Burn Hazards

Batteries contain acid. Always wear protective clothing and eye wear when working with batteries.

Avoid spilling or contacting battery acid. Neutralize battery acid spills with baking soda and water.

Explosion Hazard

Keep sparks, flames and lighted tobacco away from batteries. Batteries emit explosive gas.

Electrocution Hazard

Avoid contact with electrical terminals.

⚠ Welder Safety

Read, understand and obey all warnings and instructions provided with the welding power unit.

Do not connect weld leads or cables unless the welding power unit is turned off at the platform controls.

Do not operate unless the weld cables are properly connected and the welder is properly grounded.

The weight of the welder will reduce the rated platform capacity and must be factored into the total platform load. The welder power supply weighs 75 lbs / 34 kg.

Do not operate the welder unless a fire extinguisher is immediately available for instant use, per OSHA regulation 1926.352(d).

⚠ Weld Line to Platform Safety

Read, understand and obey all warnings and instructions provided with the welding power unit.

Do not connect weld leads or cables unless the welding power unit is turned off at the platform controls.

Do not operate unless the weld cables are properly connected.

Connect the positive lead to the twist-lock connector at the turntable and platform.

Clamp the negative lead to the ground post at the turntable and platform.

Lockout After Each Use

- 1 Select a safe parking location—firm level surface, clear of obstruction and traffic.
- 2 Retract and lower the boom to the stowed position.
- 3 Rotate the turntable so that the boom is between the non-steer wheels.
- 4 Turn the key switch to the off position and remove the key to secure from unauthorized use.
- 5 Chock the wheels.

Legend

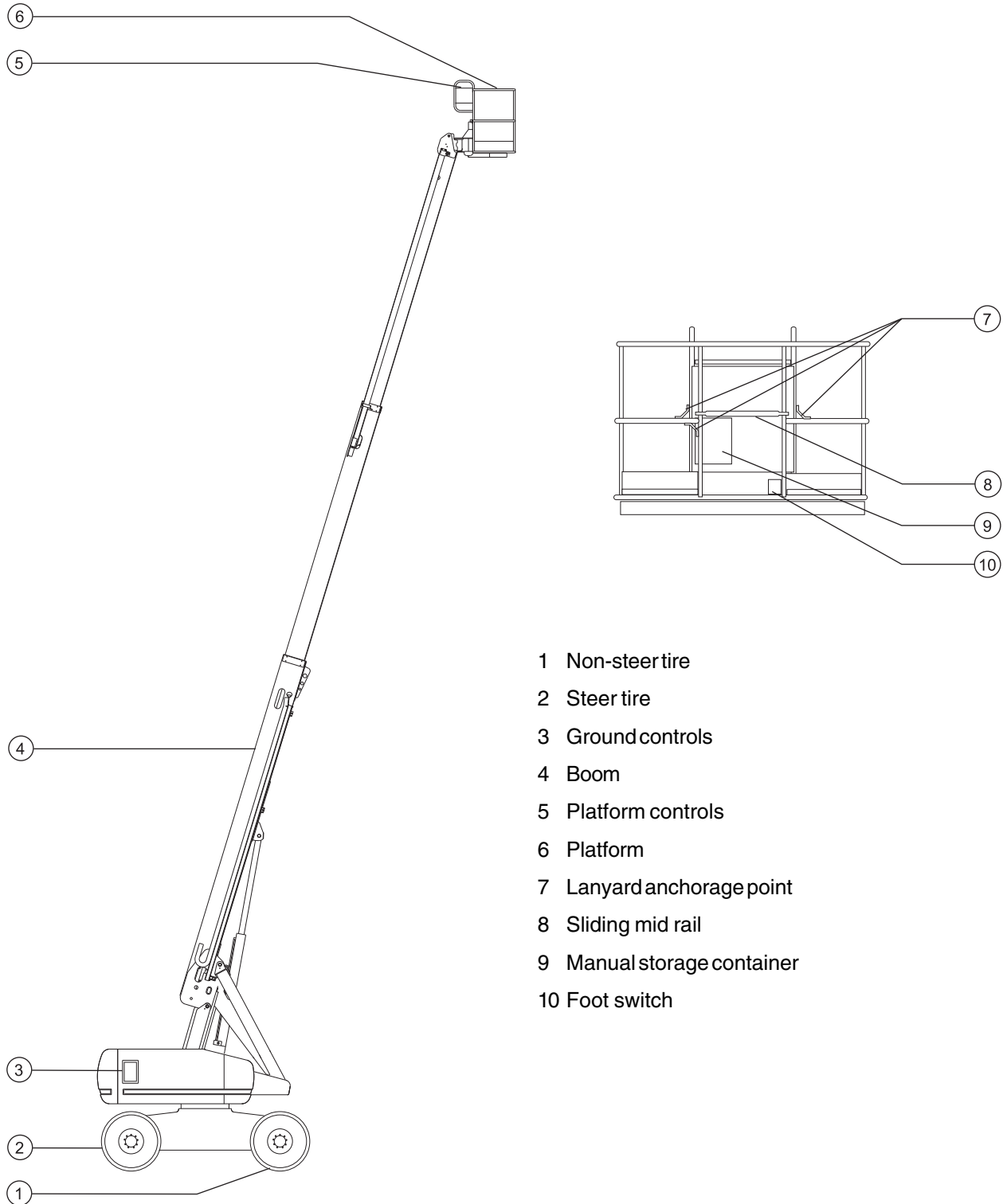

- 1 Non-steer tire
- 2 Steer tire
- 3 Ground controls
- 4 Boom
- 5 Platform controls
- 6 Platform
- 7 Lanyard anchorage point
- 8 Sliding mid rail
- 9 Manual storage container
- 10 Foot switch

Controls

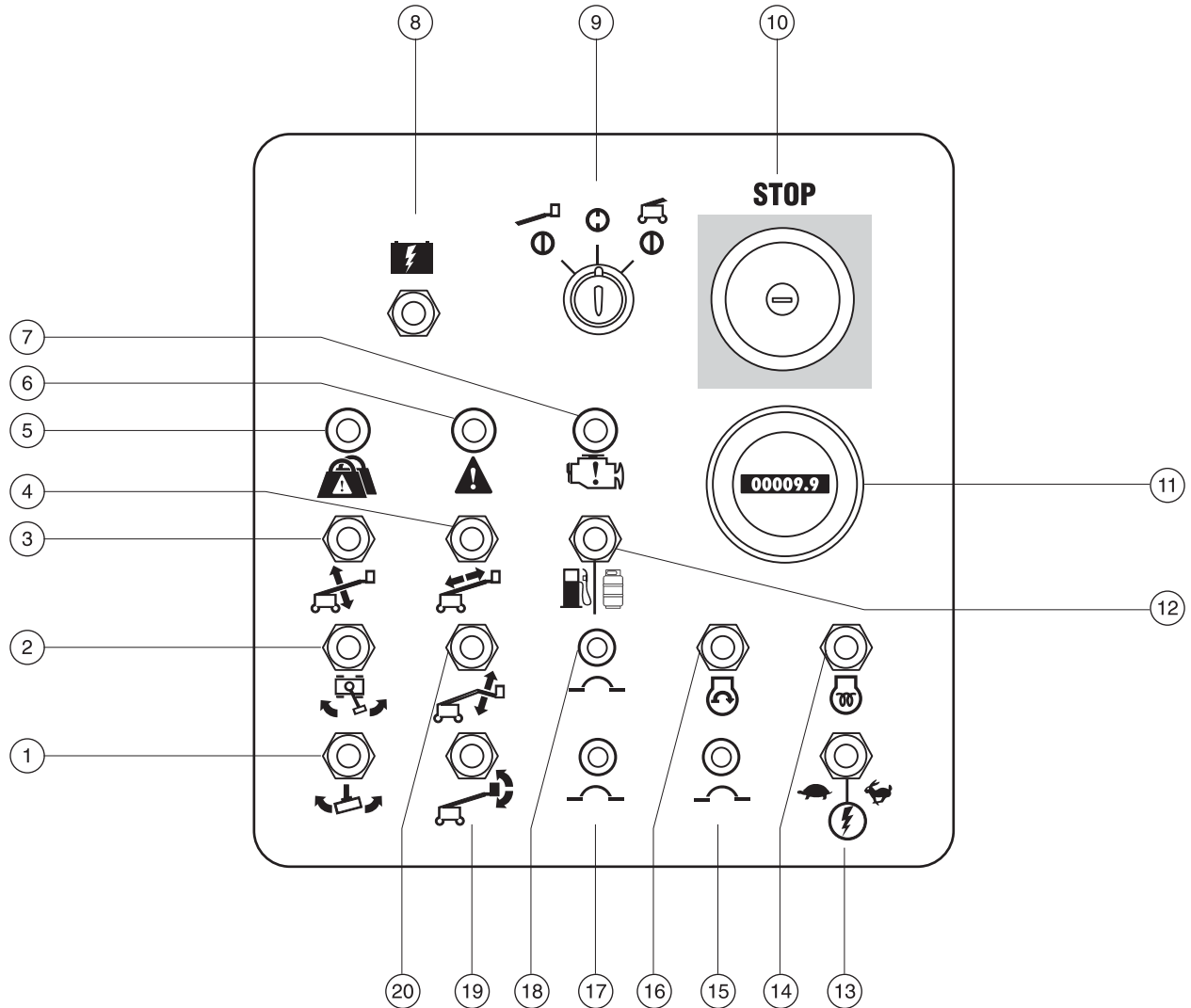

Ground Control Panel

- | | |
|--|--|
| 1 Platform rotate switch | 11 Hour meter |
| 2 Turntable rotate switch | 12 Gasoline/LPG models: Fuel select switch |
| 3 Boom up/down switch | 13 Function enable switch |
| 4 Boom extend/retract switch | 14 Diesel models: Glow plug switch |
| 5 Platform overload indicator light | 15 15A breaker for engine electrical circuits |
| 6 Machine malfunction indicator light | 16 Engine start switch |
| 7 Check engine light | 17 15A breaker for control electrical circuits |
| 8 Auxiliary power switch | 18 20A breaker for oil cooler and options |
| 9 Key switch for platform/off/ground selection | 19 Platform level switch |
| 10 Red Emergency Stop button | 20 Not used |

Controls

Ground Control Panel

1 Platform rotate switch

Move the platform rotate switch to the right and the platform will rotate to the right. Move the platform rotate switch to the left and the platform will rotate to the left.



2 Turntable rotate switch

Move the turntable rotate switch to the right and the turntable will rotate to the right. Move the turntable rotate switch to the left and the turntable will rotate to the left.



3 Boom up/down switch

Move the boom up/down switch up and the boom will raise. Move the boom up/down switch down and the boom will lower.



4 Boom extend/retract switch

Move the boom extend/retract switch to the right and the boom will extend. Move the boom extend/retract switch to the left and the boom will retract.



5 Platform overload indicator light

The platform overload indicator light will flash and no functions will operate when there is more than 1250 lbs / 567 kg in the platform. Remove weight until the light goes off.

6 Machine malfunction indicator light

Light on indicates all functions have stopped. See the instructions in the Operating Instructions section.

7 Check engine light

Light on and engine stopped: Tag the machine and remove from service.
Light on and engine still running: Contact service personnel within 24 hours.

8 Auxiliary power switch

Use auxiliary power if the primary power source (engine) fails. Simultaneously hold the auxiliary power switch to either side and activate the desired function.

9 Key switch for platform/off/ground selection

Turn the key switch to the platform position and the platform controls will operate. Turn the key switch to the off position and the machine will be off. Turn the key switch to ground position and the the ground controls will operate.

10 Red Emergency Stop button

Push in red Emergency Stop button to the off position to stop all functions and turn the engine off. Pull out the red Emergency Stop button to the on position to operate the machine.

Controls

11 Hour meter

The hour meter displays the numbers of hours the machine has operated.

12 Gasoline/LPG models: Fuel select switch

Move the fuel select switch to the gasoline position to select gasoline. Move the fuel select switch to the LPG position to select LPG.

13 Function enable switch

Move the function enable switch to either side to enable the functions on the ground control panel to operate.

14 Diesel models: Glow plug switch

Move the glow plug switch to either side and hold for 3 to 5 seconds.

15 15A breaker for engine electrical circuits

16 Engine start switch

Move the engine start switch to either side to start the engine.

17 15A breaker for control electrical circuits

18 20A breaker for oil cooler and options

19 Platform level switch

Move the platform level switch up and the level of the platform will raise. Move the platform level switch down and the level of the platform will lower.

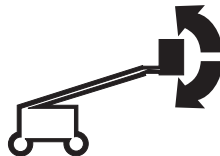

Controls

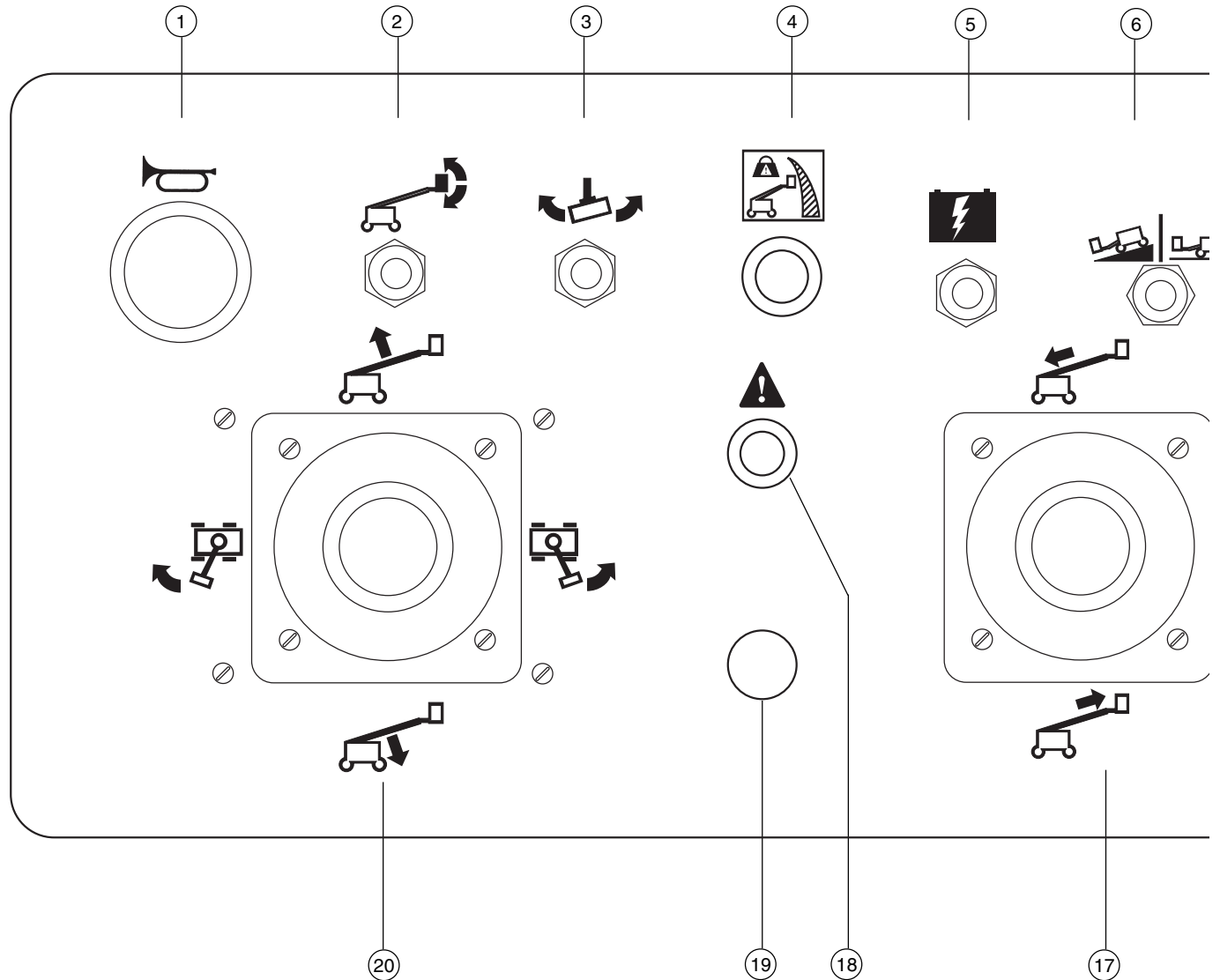

Platform Control Panel

- | | |
|--|--|
| 1 Horn button | 7 Glow plug switch |
| 2 Platform level switch | 8 Engine start switch |
| 3 Platform rotate switch | 9 Engine idle (rpm) select switch |
| 4 Restricted range of motion indicator light | · Turtle: foot switch activated low idle |
| 5 Auxiliary power switch | · Rabbit: foot switch activated high idle |
| 6 Drive speed select switch | 10 Gasoline/LPG models: Fuel select switch |
| | 11 Red Emergency Stop button |

Controls

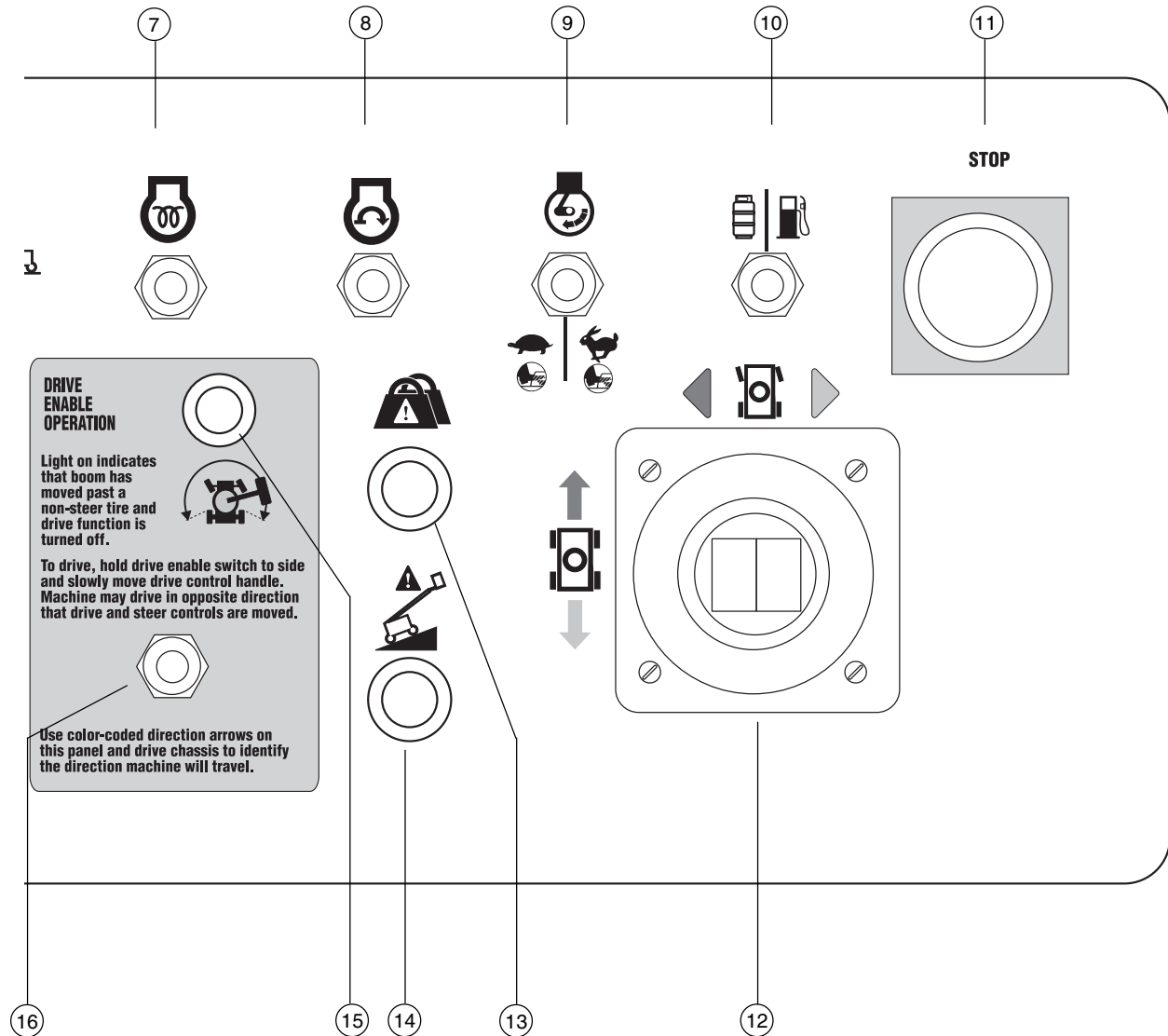

- 12 Dual axis proportional control handle for drive and steer functions
OR Proportional control handle for drive function and thumb rocker for steer function
- 13 Platform overload indicator light
- 14 Machine not level indicator light (if equipped)
- 15 Drive enable indicator light

- 16 Drive enable switch
- 17 Proportional control handle for boom extend/retract
- 18 Machine malfunction indicator light
- 19 Used for optional equipment
- 20 Dual axis proportional control handle for boom up/down and turntable rotate left/right functions



Controls

Platform Control Panel

1 Horn button

Push the horn button and the horn will sound.
Release the horn button and the horn will stop.

2 Platform level switch

Move the platform level switch up and the level of the platform will raise. Move the platform level switch down and the level of the platform will lower.

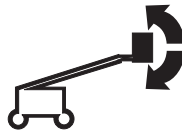

3 Platform rotate switch

Move the platform rotate switch to the right and the platform will rotate to the right. Move the platform rotate switch to the left and the platform will rotate to the left.

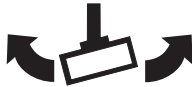

4 Restricted range of motion indicator light

Light is on when there is more than 750 lbs / 340 kg in the platform, but less than 1250 lbs / 567 kg. The range of motion of the machine is restricted.



5 Auxiliary power switch

Use auxiliary power if the primary power source (engine) fails.
Simultaneously hold the auxiliary power switch to either side and activate the desired function.

6 Drive speed select switch

Machine on incline symbol: Low range operation for inclines.

Machine on level surface symbol: High range operation for maximum drive speed.

7 Glow plug switch

Move the glow plug switch to either side and hold for 3 to 5 seconds.

8 Engine start switch

Move the engine start switch to either side to start the engine.

9 Engine idle (rpm) select switch

Move the engine idle select switch to the turtle position for foot switch activated low idle.
Move the engine idle select switch to the rabbit position for foot switch activated high idle.

10 Gasoline/LPG models: Fuel select switch

Move the fuel select switch to the gasoline position to select gasoline. Move the fuel select switch to the LPG position to select LPG.

11 Red Emergency Stop button

Push in red Emergency Stop button to the off position to stop all functions and turn the engine off. Pull out the red Emergency Stop button to the on position to operate the machine.

Controls

- 12 Dual axis proportional control handle for drive and steer functions
OR Proportional control handle for drive function and thumb rocker for steer function

Move the control handle in the direction indicated by the blue arrow on the control panel and the machine will drive forward. Move the control handle in the direction indicated by the yellow arrow and the machine will drive backwards. Move the control handle in the direction indicated by the blue triangle and the machine will steer to the left. Move the control handle in the direction indicated by the yellow triangle and the machine will steer to the right.

OR
Move the control handle in the direction indicated by the blue arrow on the control panel and the machine will drive forward. Move the control handle in the direction indicated by the yellow arrow and the machine will drive backwards. Press the left side of the thumb rocker and the machine will steer to the left. Press the right side of the thumb rocker and the machine will steer to the right.

- 13 Platform overload indicator light

The platform overload indicator light will flash and no functions will operate when there is more than 1250 lbs / 567 kg in the platform.

- 14 Machine not level indicator light (if equipped)

The machine not level indicator light will come on when the tilt alarm sounds.

- 15 Drive enable indicator light

Light on indicates that the boom has moved just past either non-steer wheel and drive function has been interrupted.

- 16 Drive enable switch

To drive when the drive enable light is on, hold the drive enable switch to either side and slowly move the drive control handle off center. Be aware that the machine may move in the opposite direction that the drive and steer controls are moved.

- 17 Proportional control handle for boom extend/retract

Move the control handle up and the boom will retract. Move the control handle down and the boom will extend.

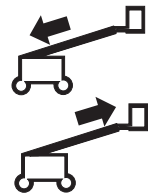

- 18 Machine malfunction indicator light

Light on indicates all functions have stopped. See the instructions in the Operating Instructions section.

- 19 Used for optional equipment

- 20 Dual axis proportional control handle for boom up/down and turntable rotate left/right functions

Move the control handle up and the boom will raise. Move the control handle down and the boom will lower. Move the control handle to the right and the turntable will rotate to the right. Move the control handle to the left and the turntable will rotate to the left.

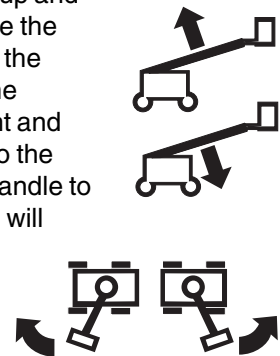

Inspections



Do Not Operate Unless:

- You learn and practice the principles of safe machine operation contained in this operator's manual.
 - 1 Avoid hazardous situations.
 - 2 Always perform a pre-operation inspection.**
- Know and understand the pre-operation inspection before going on to the next section.**
- 3 Always perform function tests prior to use.
- 4 Inspect the workplace.
- 5 Only use the machine as it was intended.

Pre-operation Inspection Fundamentals

It is the responsibility of the operator to perform a pre-operation inspection and routine maintenance.

The pre-operation inspection is a visual inspection performed by the operator prior to each work shift. The inspection is designed to discover if anything is apparently wrong with a machine before the operator performs the function tests.

The pre-operation inspection also serves to determine if routine maintenance procedures are required. Only routine maintenance items specified in this manual may be performed by the operator.

Refer to the list on the next page and check each of the items.

If damage or any unauthorized variation from factory delivered condition is discovered, the machine must be tagged and removed from service.

Repairs to the machine may only be made by a qualified service technician, according to the manufacturer's specifications. After repairs are completed, the operator must perform a pre-operation inspection again before going on to the function tests.

Scheduled maintenance inspections shall be performed by qualified service technicians, according to the manufacturer's specifications and the requirements listed in the responsibilities manual.

Inspections

Pre-operation Inspection

- ❑ Be sure that the operator's, safety and responsibilities manuals are complete, legible and in the storage container located in the platform.
- ❑ Be sure that all decals are legible and in place. See Inspections section.
- ❑ Check for engine oil leaks and proper oil level. Add oil if needed. See Maintenance section.
- ❑ Check for hydraulic oil leaks and proper oil level. Add oil if needed. See Maintenance section.
- ❑ Check for engine coolant leaks and proper level of coolant. Add coolant if needed. See Maintenance section.
- ❑ Check for battery fluid leaks and proper fluid level. Add distilled water if needed. See Maintenance section.
- ❑ Check for proper tire pressure. Add air if needed. See Maintenance section.

Check the following components or areas for damage, improperly installed or missing parts and unauthorized modifications:

- ❑ Electrical components, wiring and electrical cables
- ❑ Hydraulic hoses, fittings, cylinders and manifolds
- ❑ Fuel and hydraulic tanks
- ❑ Drive and turntable motors and drive hubs
- ❑ Boom wear pads
- ❑ Tires and wheels
- ❑ Engine and related components

- ❑ Limit switches and horn
- ❑ Alarms and beacons (if equipped)
- ❑ Nuts, bolts and other fasteners
- ❑ Platform entry mid-rail or gate

Check entire machine for:

- ❑ Cracks in welds or structural components
- ❑ Dents or damage to machine
- ❑ Excessive rust, corrosion or oxidation
- ❑ Be sure that all structural and other critical components are present and all associated fasteners and pins are in place and properly tightened.
- ❑ After you complete your inspection, be sure that all compartment covers are in place and latched.

Inspections



Do Not Operate Unless:

- ☑ You learn and practice the principles of safe machine operation contained in this operator's manual.
 - 1 Avoid hazardous situations.
 - 2 Always perform a pre-operation inspection.
 - 3 Always perform function tests prior to use.**
- Know and understand the function tests before going on to the next section.**
- 4 Inspect the workplace.
 - 5 Only use the machine as it was intended.

Function Test Fundamentals

The function tests are designed to discover any malfunctions before the machine is put into service. The operator must follow the step-by-step instructions to test all machine functions.

A malfunctioning machine must never be used. If malfunctions are discovered, the machine must be tagged and removed from service. Repairs to the machine may only be made by a qualified service technician, according to the manufacturer's specifications.

After repairs are completed, the operator must perform a pre-operation inspection and function tests again before putting the machine into service.

- 1 Select a test area that is firm, level and free of obstruction.

At the Ground Controls

- 2 Turn the key switch to ground control.
- 3 Pull out the red Emergency Stop button to the on position.
- ⊙ Result: The beacon (if equipped) should flash.
- 4 Start the engine (see Operating Instructions section).

Test Emergency Stop

- 5 Push in the red Emergency Stop button to the off position.
- ⊙ Result: The engine should turn off and all functions should not operate.
- 6 Pull out the red Emergency Stop button to the on position and restart the engine.

Inspections

Test the Machine Functions

- 7 Do not hold the function enable switch to either side. Attempt to activate each boom and platform function toggle switch.



- ⦿ Result: All boom and platform functions should not operate.

- 8 Hold the function enable switch to either side and activate each boom and platform function toggle switch.

- ⦿ Result: All boom and platform functions should operate through a full cycle. The descent alarm (if equipped) should sound while the boom is lowering.

Test the Tilt Sensor

- 9 Pull out the platform red Emergency Stop button to the on position. Turn the key switch to platform control.

- 10 Open the tank side turntable cover and locate the tilt sensor next to the fuel tank.

- 11 Press down one side of the tilt sensor.

- ⦿ Result: The alarm, located in the platform, should sound.

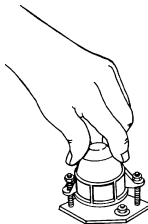

Test Auxiliary Controls

- 12 Turn the key switch to ground control and shut the engine off.

- 13 Pull out the red Emergency Stop button to the on position.

- 14 Simultaneously hold the auxiliary power switch on and activate each boom function toggle switch.



Note: To conserve battery power, test each function through a partial cycle.

- ⦿ Result: All boom functions should operate.

At the Platform Controls

Test Emergency Stop

- 15 Turn the key switch to platform control and restart the engine.

- 16 Push in the platform red Emergency Stop button to the off position.

- ⦿ Result: The engine should turn off and all functions should not operate.

- 17 Pull out the red Emergency Stop button and restart the engine.

Test the Horn

- 18 Push the horn button.

- ⦿ Result: The horn should sound.

Inspections

Test the Foot Switch

- 19 Push in the platform red Emergency Stop button to the off position.
 - 20 Pull out the red Emergency Stop button to the on position but do not start the engine.
 - 21 Press down the foot switch and attempt to start the engine by moving the start toggle switch to either side.
- ⦿ Result: The engine should not start.
- 22 Do not press down the foot switch and restart the engine.
 - 23 Do not press down the foot switch. Test each machine function.
- ⦿ Result: The machine functions should not operate.

Test Machine Functions

- 24 Press down the foot switch.
 - 25 Activate each machine function control handle or toggle switch.
- ⦿ Result: All boom/platform functions should operate through a full cycle.

Test the Steering

- 26 Press down the foot switch.
 - 27 Press the thumb rocker switch on top of the drive control handle in the direction indicated by the blue triangle on the control panel OR slowly move the drive/steer control handle in the direction indicated by the blue triangle.
- ⦿ Result: The steer wheels should turn in the direction that the blue triangles point on the drive chassis.
- 28 Press the thumb rocker switch in the direction indicated by the yellow triangle on the control panel OR slowly move the drive/steer handle in the direction indicated by the yellow triangle.
- ⦿ Result: The steer wheels should turn in the direction that the yellow triangles point on the drive chassis.

Test Drive and Braking

- 29 Press down the foot switch.
 - 30 Slowly move the drive control handle in the direction indicated by the blue arrow on the control panel until the machine begins to move, then return the handle to the center position.
- ⦿ Result: The machine should move in the direction that the blue arrow points on the drive chassis, then come to an abrupt stop.
- 31 Slowly move the drive control handle in the direction indicated by the yellow arrow on the control panel until the machine begins to move, then return the handle to the center position.
- ⦿ Result: The machine should move in the direction that the yellow arrow points on the drive chassis, then come to an abrupt stop.

Note: The brakes must be able to hold the machine on any slope it is able to climb.

Inspections

Test the Oscillating Axle (if equipped)

- 32 Start the engine from the platform controls.
- 33 Drive the right steer tire up onto a 6 inch / 15.2 cm block or curb.
 - ⦿ Result: The three remaining tires should stay in firm contact with the ground.
- 34 Drive the left steer tire up onto a 6 inch / 15.2 cm block or curb.
 - ⦿ Result: The three remaining tires should stay in firm contact with the ground.
- 35 Drive both steer tires up onto a 6 inch / 15.2 cm block or curb.
 - ⦿ Result: The non-steer tires should stay in firm contact with the ground.

Test the Drive Enable System

- 36 Press down the foot switch and lower the boom to the stowed position.
- 37 Rotate the turntable until the boom moves past one of the non-steer wheels.

- ⦿ Result: The drive enable indicator light should come on and remain on while the boom is anywhere in the range shown.



- 38 Move the drive control handle off center.
 - ⦿ Result: The drive function should not operate.

- 39 Move and hold the drive enable toggle switch to either side and slowly move the drive control handle off center.

- ⦿ Result: The drive function should operate.

Note: When the drive enable system is in use, the machine may drive in the opposite direction that the drive and steer control handle is moved.

Use the color-coded direction arrows on the platform controls and the drive chassis to identify the direction of travel.

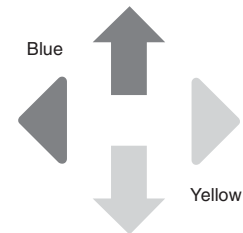

Test Limited Drive Speed

- 40 Press down the foot switch.
- 41 Raise the boom to just above horizontal.

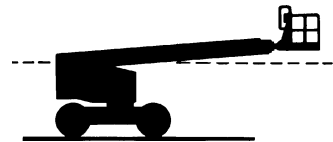

- 42 Slowly move the drive control handle to the full drive position.
 - ⦿ Result: The maximum achievable drive speed with the boom raised should not exceed 1 foot / 30 cm per second.

- 43 Lower the boom to the stowed position.

Inspections

44 Extend the boom 1 foot / 30 cm.

45 Slowly move the drive control handle to the full drive position.

- ⦿ Result: The maximum achievable drive speed with the boom extended should not exceed 1 foot / 30 cm per second.

If the drive speed with the boom raised or extended exceeds 1 foot / 30 cm per second, immediately tag and remove the machine from service.

Test Auxiliary Controls

46 Shut off the engine.

47 Pull out the red Emergency Stop button to the on position.

48 Press down the foot switch.

49 Simultaneously hold the auxiliary power switch on and activate each function control handle or toggle switch.

Note: To conserve battery power, test each function through a partial cycle.

- ⦿ Result: All boom and steer functions should operate. Drive functions should not operate with auxiliary power.

Test the Lift/Drive Select Function (CE only)

50 Press down the foot switch.

51 Move the drive control handle off center.

52 Activate each boom function toggle switch.

- ⦿ Result: No boom functions should operate. The machine will move in the direction indicated on the control panel.

Inspections



Do Not Operate Unless:

- You learn and practice the principles of safe machine operation contained in this operator's manual.
 - 1 Avoid hazardous situations.
 - 2 Always perform a pre-operation inspection.
 - 3 Always perform function tests prior to use.
 - 4 Inspect the workplace.**
Know and understand the workplace inspection before going on to the next section.
 - 5 Only use the machine as it was intended.

Fundamentals

The workplace inspection helps the operator determine if the workplace is suitable for safe machine operation. It should be performed by the operator prior to moving the machine to the workplace.

It is the operator's responsibility to read and remember the workplace hazards, then watch for and avoid them while moving, setting up and operating the machine.

Workplace Inspection

Be aware of and avoid the following hazardous situations:

- drop-offs or holes
- bumps, floor obstructions or debris
- sloped surfaces
- unstable or slippery surfaces
- overhead obstructions and high voltage conductors
- hazardous locations
- inadequate surface support to withstand all load forces imposed by the machine
- wind and weather conditions
- the presence of unauthorized personnel
- other possible unsafe conditions

Inspections

Inspection for Decals with Words

Determine whether the decals on your machine have words or symbols. Use the appropriate inspection to verify that all decals are legible and in place.

Part No.	Decal Description	Quantity	Part No.	Decal Description	Quantity
25994	Notice - Component Damage Hazard	1	62077	Cosmetic - S-60	1
27204	Arrow - Blue	1	72168	Label - Starter Battery	1
27205	Arrow - Yellow	1	72169	Label - Controls Battery	1
27206	Triangle - Blue	2	72867	Label - Lights (option)	1
27207	Triangle - Yellow	2	82366	Label - Chevron Rykon	1
27564	Danger - Electrocutation Hazard	2	82455	Ground Control Panel	1
28158	Label - Unleaded	1	82644	Instructions - Perkins Diesel Engine Specs	1
28159	Label - Diesel	1	82677	Danger/Label - Tire Specifications	4
28160	Label - Liquid Petroleum Gas	1	97548	Instructions - Deutz Diesel Engine Specs	1
28161	Warning - Crushing Hazard	4	97571	Instructions - Ford Engine Specs	1
28165	Instructions - Foot Switch	1	97602	Warning - Explosion Hazard	1
28174	Label - Power to Platform, 230V	2	97815	Label - Lower Mid-rail	1
28175	Warning - Compartment Access	1	97887	Instructions - Maximum Side Force, 150 lbs / 667 N	1
28176	Label - Missing Manuals	1	97890	Danger - Safety Rules	2
28177	Warning - Platform Rotate	2	114099	Label - Transport Diagram	2
28181	Warning - No Step or Ride	1	114169	Instructions - Ford Engine Specs	1
28235	Label - Power to Platform, 115V	2	114240	Label - TCON Software	1
28236	Warning - Improper Operation	1	114241	Label - SCON Software	1
31060	Danger - Tip-over Hazard, Interlock	3	114258	Danger - Explosion Hazard	1
32728	Label - Generator (option)	1	114269	Warning - Weld Line to Platform	2
33952	Danger - Tilt Alarm	1	114277	Label - Belt Routing	1
40434	Label - Lanyard Anchorage	3	1000005	Platform Control Panel	1
44981	Label - Air Line to Platform	2	1000192	Instructions - Maximum Load Chart	2
44986	Instructions - Maximum Manual Force, 90 lbs / 400 N	1	1000198	Instructions - Operating Instructions	2
52607	Label - Test	1	1000199	Cosmetic - Genie S-60 HC	1
52966	Cosmetic - 4 x 2	1	1000200	Label - Wheel Load, S-60 HC	4
52967	Cosmetic - 4 x 4	1	1000262	Warning - Tip-over, Platform Replacement	1



Inspections

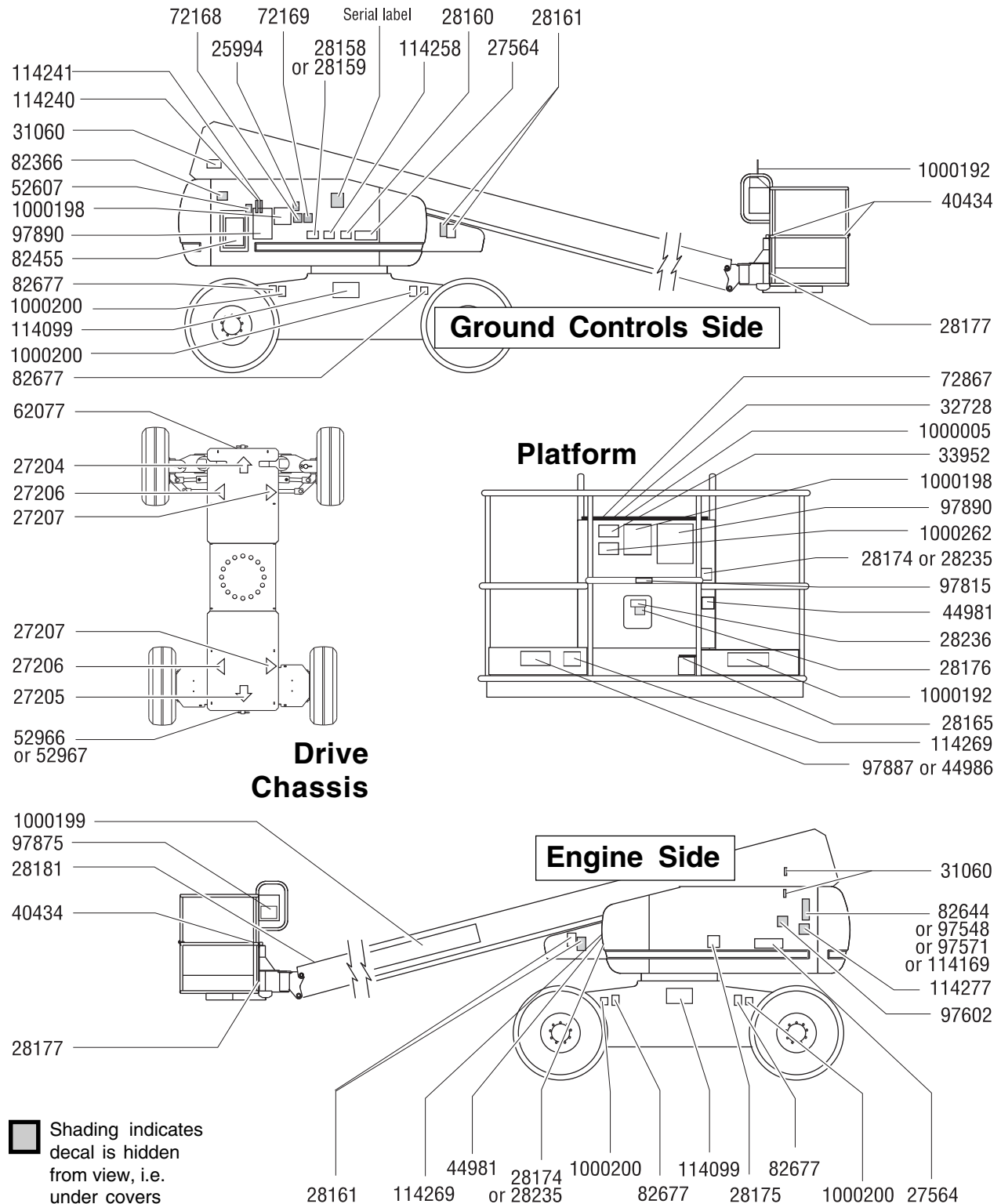

Inspections

Inspection for Decals with Symbols

Determine whether the decals on your machine have words or symbols. Use the appropriate inspection to verify that all decals are legible and in place.

Part No.	Decal Description	Quantity
27204	Arrow - Blue	1
27205	Arrow - Yellow	1
27206	Triangle - Blue	2
27207	Triangle - Yellow	2
28158	Label - Unleaded	2
28159	Label - Diesel	2
28160	Label - Liquid Petroleum Gas	1
28174	Label - Power to Platform, 230V	2
28235	Label - Power to Platform, 115V	2
32728	Label - Generator (option)	1
40434	Label - Lanyard Anchorage	3
44981	Label - Air Line to Platform	2
52966	Cosmetic - 4 x 2	1
52967	Cosmetic - 4 x 4	1
62077	Cosmetic - S-60	1
72867	Label - Lights (option)	1
82455	Ground Control Panel	1
82472	Label - Crushing Hazard	4
82473	Label - Compartment Access	1
82487	Label - Read the Manual	2
82544	Label - Electrocution Hazard	2
82548	Label - Platform Rotate	2

Part No.	Decal Description	Quantity
82551	Label - Tire Pressure	4
82602	Label - Max Side Force, 667 N	1
82604	Label - Max Manual Force, 400 N	1
82646	Label - Drive Enable Patch	1
97815	Label - Lower Mid-rail	1
114098	Label - Maximum Capacity	2
114099	Label - Transport Diagram	2
114247	Label - Fall Hazard	1
114248	Label - Tilt Alarm	1
114249	Label - Tire Specifications	4
114251	Label - Explosion Hazard	1
114252	Label - Tip-over Hazard	3
1000005	Platform Control Panel	1
1000199	Cosmetic - Genie S-60 HC	1
1000200	Label - Wheel Load, S-60	4

Inspections

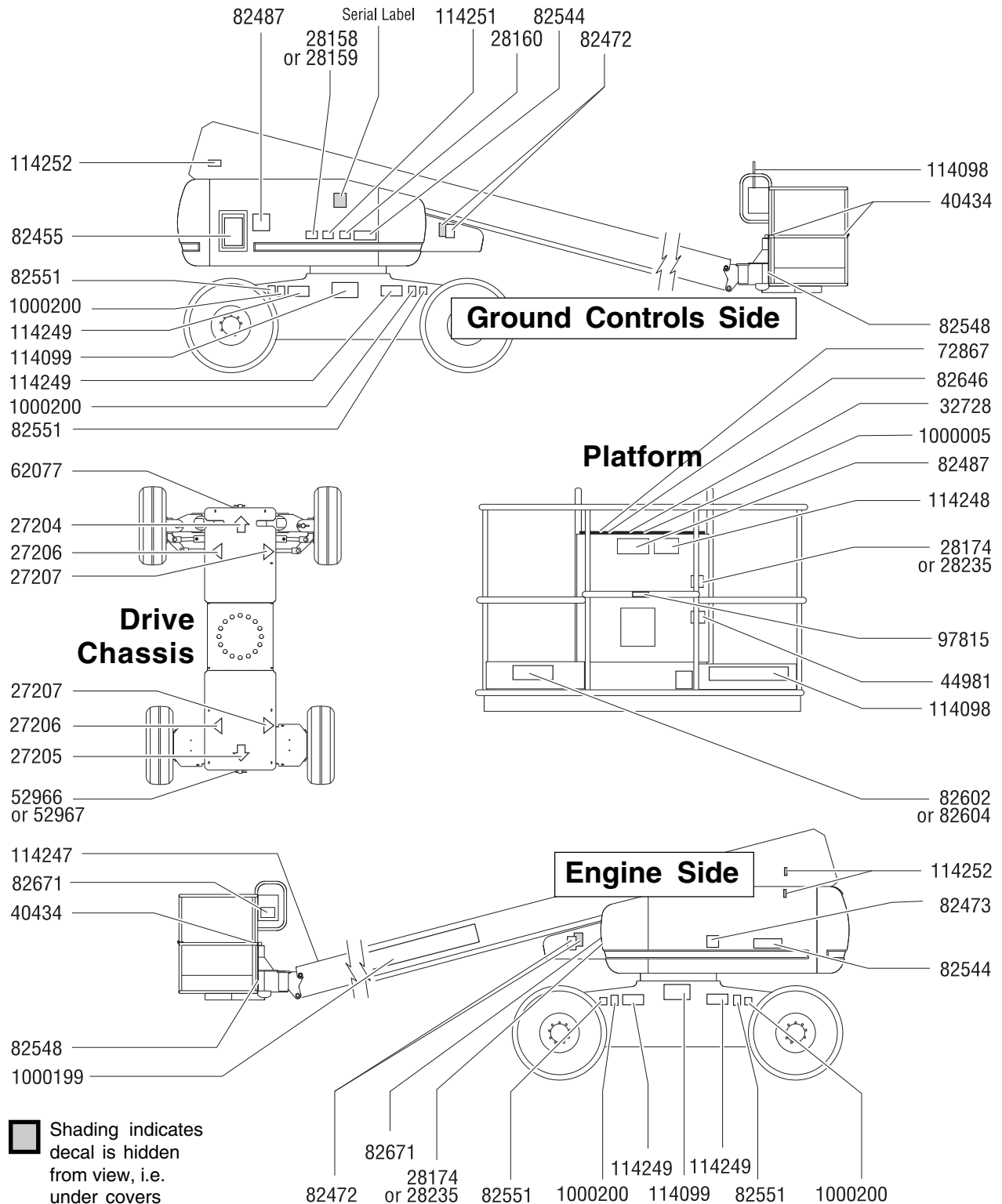

Operating Instructions



Do Not Operate Unless:

- You learn and practice the principles of safe machine operation contained in this operator's manual.
 - 1 Avoid hazardous situations.
 - 2 Always perform a pre-operation inspection.
 - 3 Always perform function tests prior to use.
 - 4 Inspect the workplace.
 - 5 Only use the machine as it was intended.**

Fundamentals

The Operating Instructions section provides instructions for each aspect of machine operation. It is the operator's responsibility to follow all the safety rules and instructions in the operator's, safety and responsibilities manuals.

Using the machine for anything other than lifting personnel, along with their tools and materials, to an aerial work site is unsafe and dangerous.

Only trained and authorized personnel should be permitted to operate a machine. If more than one operator is expected to use a machine at different times in the same work shift, they must all be qualified operators and are all expected to follow all safety rules and instructions in the operator's, safety and responsibilities manuals. That means every new operator should perform a pre-operation inspection, function tests, and a workplace inspection before using the machine.

Operating Instructions

Starting the Engine

- 1 At the ground controls, turn the key switch to the desired position.
- 2 Be sure both ground and platform control red Emergency Stop buttons are pulled out to the on position.



Gasoline/LPG models

- 3 Choose fuel by moving the fuel select switch to the desired position.
- 4 Move the engine start toggle switch to either side. If the engine fails to start or dies, the restart delay will disable the start switch for 3 seconds.

Diesel models

- 3 Move the glow plug switch (if equipped) to either side and hold for 3 to 5 seconds.
- 4 Move the engine start toggle switch to either side. If the engine fails to start or dies, the restart delay will disable the start switch for 3 seconds.

All models

If the engine fails to start after 15 seconds of cranking, determine the cause and repair any malfunction. Wait 60 seconds before trying to start again.

In cold conditions, 20°F / -6°C and below, warm the engine for 5 minutes before operating to prevent hydraulic system damage.

In extreme cold conditions, 0°F / -18°C and below, machines should be equipped with optional cold start kits. Attempting to start the engine when temperatures are below 0°F / -18°C may require the use of a booster battery.

Gasoline/LPG models: In cold conditions, 20°F / -6°C and below, the machine should be started on gasoline and warmed for 2 minutes, then switched to LPG. Warm engines can be started on LPG.

Emergency Stop

Push in either the ground or platform red Emergency Stop button to the off position to stop all functions and turn the engine off.

Repair any function that operates when the red Emergency Stop button is pushed in.

Selecting and operating the ground controls will override the platform red Emergency Stop button.

Auxiliary Controls

Use auxiliary power if the primary power source (engine) fails.

- 1 Turn the key switch to ground or platform control.
- 2 Pull out the red Emergency Stop button to the on position.
- 3 Press down the foot switch when operating the auxiliary controls from the platform.
- 4 Simultaneously hold the auxiliary power switch on and activate the desired function.



The drive function will not operate with auxiliary power.

Operating Instructions

Operation from Ground

- 1 Turn the key switch to ground control.
- 2 Pull out the red Emergency Stop button to the on position.
- 3 Gasoline/LPG models: Choose fuel by moving the fuel select switch to the desired position.
- 4 Start the engine.

To Position Platform

- 1 Hold the function enable switch to either side.
- 2 Move the appropriate toggle switch according to the markings on the control panel.



Drive and steer functions are not available from the ground controls.

Operation from Platform

- 1 Turn the key switch to platform control.
- 2 Pull out both ground and platform red Emergency Stop buttons to the on position.
- 3 Gasoline/LPG models: Choose fuel by moving the fuel select switch to the desired position.
- 4 Start the engine. Do not press down the foot switch when starting the engine.

To Position Platform

- 1 Press down the foot switch.
- 2 Slowly move the appropriate function control handle or toggle switch according to the markings on the control panel.

To Steer

- 1 Press down the foot switch.
- 2 Turn the steer wheels with the thumb rocker switch located on top of the drive control handle.

Use the color-coded direction triangles on the platform controls and the drive chassis to identify the direction the wheels will turn.

To Drive

- 1 Press down the foot switch.
- 2 Increase speed: Slowly move the drive control handle off center.
Decrease speed: Slowly move the drive control handle toward center.
Stop: Return the drive control handle to center or release the foot switch.

Use the color-coded direction arrows on the platform controls and the drive chassis to identify the direction the machine will travel.

Machine travel speed is restricted when the boom is raised or extended.

Operating Instructions

Driving on a slope

Determine the uphill, downhill and side slope ratings for the machine and determine the slope grade.



Maximum slope rating, counterweight uphill (gradeability):
2WD: 30% (17°)
4WD: 45% (24°)



Maximum slope rating, counterweight downhill:
2WD: 10% (6°)
4WD: 30% (17°)



Maximum side slope rating:
25% (14°)

Note: Slope rating is subject to ground conditions and adequate traction. The term gradeability applies to the counterweight uphill configuration only.

Be sure the boom is below horizontal and the platform is between the non-steer wheels.

Move the drive speed select switch to machine on incline symbol.

To determine the slope grade:

Measure the slope with a digital inclinometer OR use the following procedure.

You will need:

- carpenter's level
- straight piece of wood, at least 3 feet / 1 m long
- tape measure

Lay the piece of wood on the slope.

At the downhill end, lay the level on the top edge of the piece of wood and lift the end until the piece of wood is level.

While holding the piece of wood level, measure the vertical distance from the bottom of the piece of wood to the ground.

Divide the tape measure distance (rise) by the length of the piece of wood (run) and multiply by 100.

Example:

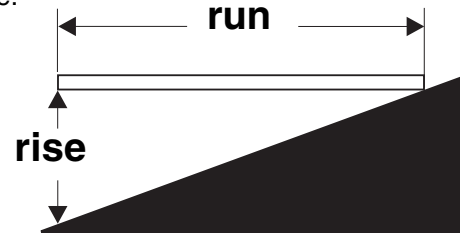

Piece of wood = 144 inches (3.6 m)

Run = 144 inches (3.6 m)

Rise = 12 inches (0.3 m)

$12 \text{ in} \div 144 \text{ in} = 0.083 \times 100 = 8.3\% \text{ grade}$

$0.3 \text{ m} \div 3.6 \text{ m} = 0.083 \times 100 = 8.3\% \text{ grade}$

If the slope exceeds the maximum uphill, downhill or side slope rating, then the machine must be winched or transported up or down the slope. See Transport and Lifting section.

Operating Instructions

Drive Enable

Light on indicates that the boom has moved just past either non-steer wheel and drive function has been interrupted.



To drive, hold the drive enable switch to either side and slowly move the drive control handle off center.

Be aware that the machine may move in the opposite direction that the drive and steer controls are moved.

Always use the color-coded direction arrows on the platform controls and the drive chassis to identify the direction the machine will travel.

Engine Idle Select (rpm)

Select engine idle (rpm) using the symbols on the control panel.



When the foot switch is not pressed, the engine will idle at the lowest rpm.

- Turtle symbol: Foot switch activated low idle
- Rabbit symbol: Foot switch activated high idle

Drive Speed Select



- Machine on incline symbol: Low range operation for inclines
- Machine on level surface symbol: High range operation for maximum drive speed

Generator (if equipped)

To operate the generator, move the generator toggle switch to the on position. The engine will continue to run but no drive or platform functions will operate.

Plug a power tool into the power to platform GFCI outlet.

To resume machine functions, move the generator toggle switch to the off position. All functions will operate.

Check Engine Light



Light on and engine stopped: Tag the machine and remove from service.

Light on and engine still running: Contact service personnel within 24 hours.

Machine Not Level Indicator Light (if equipped)



Light on indicates machine is not level. The tilt alarm will be sounding when this light is on. Move the machine to a firm level surface.

Machine Malfunction Indicator Light



Light on indicates all functions have stopped.

- 1 Push in and then pull out the red Emergency Stop button.
- 2 Lower and retract the boom.
- 3 Tag the machine and remove from service. Functions will not operate.

Operating Instructions

Unrestricted and restricted range of motion

Determine the weight of all occupants, equipment and materials in the platform.

Refer to the load chart on this page or on the machine to determine the available working range of motion.

Less than 751 lbs / 340 kg: The range of motion is unrestricted.

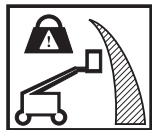

751-1250 lbs / 340-567 kg: The range of motion is restricted. The amber restricted range of motion indicator light will be on.

The machine will stop and the indicator light will flash when the machine reaches the limit of the restricted range of motion. Raise or retract the boom to continue.



Over 1250 lbs / 567 kg: The red platform overload indicator light will flash and no functions will operate. Remove weight until the light goes off.



If the platform is overloaded when it is outside the restricted range of motion, the red platform overload light will flash and no functions will operate. Move the auxiliary power switch and the boom will retract.

Unrestricted and restricted range of motion

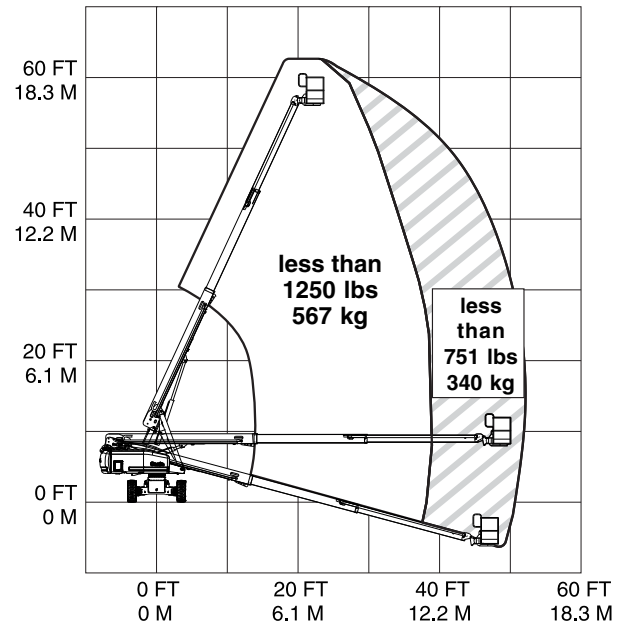

Transport and Lifting Instructions



Observe and Obey:

- ☑ Genie Industries provides this securement information as a recommendation. Drivers are solely responsible for making sure machines are properly secured and the correct trailer is selected pursuant to US Department of Transportation regulations, other localized regulations, and their company policy.
- ☑ Genie customers needing to containerize any lift or Genie product should source a qualified freight forwarder with expertise in preparing, loading and securing construction and lifting equipment for international shipment.
- ☑ Only qualified aerial lift operators should move the machine on or off the truck.
- ☑ The transport vehicle must be parked on a level surface.
- ☑ The transport vehicle must be secured to prevent rolling while the machine is being loaded.
- ☑ Be sure the vehicle capacity, loading surfaces and chains or straps are sufficient to withstand the machine weight. Genie lifts are very heavy relative to their size. See the serial label for the machine weight. See the Inspections section for the serial label location.
- ☑ Be sure the turntable is secured with the turntable rotation lock before transporting. Be sure to unlock the turntable for operation.

- ☑ Do not drive the machine on a slope that exceeds the uphill, downhill or side slope rating. See Driving on a Slope in the Operating Instructions section.
- ☑ If the slope of the transport vehicle bed exceeds the uphill or downhill maximum slope rating, the machine must be loaded and unloaded using a winch as described. See the Specifications section for the slope ratings.

Free-wheel Configuration for Winching

Chock the wheels to prevent the machine from rolling.

2WD models: Release the non-steer wheel brakes by turning over the drive hub disconnect caps.

4WD models: Release the wheel brakes by turning over all four drive hub disconnect caps.

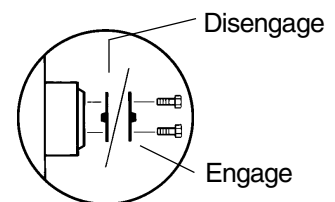

Be sure the winch line is properly secured to the drive chassis tie points and the path is clear of all obstructions.

Reverse the procedures described to re-engage the brakes.

Note: The pump free-wheel valve should always remain closed.

Transport and Lifting Instructions

⚠ Securing to Truck or Trailer for Transit

Always use the turntable rotation lock pin each time the machine is transported.

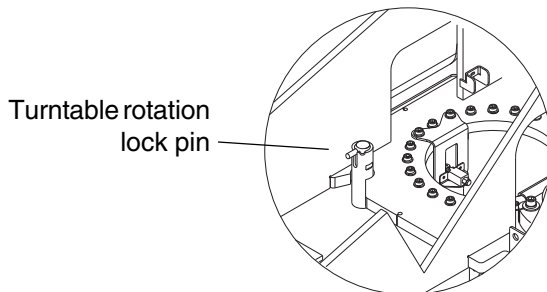

Turn the key switch to the off position and remove the key before transporting.

Inspect the entire machine for loose or unsecured items.

Securing the Chassis

Use chains of ample load capacity.

Use a minimum of 5 chains.

Adjust the rigging to prevent damage to the chains.

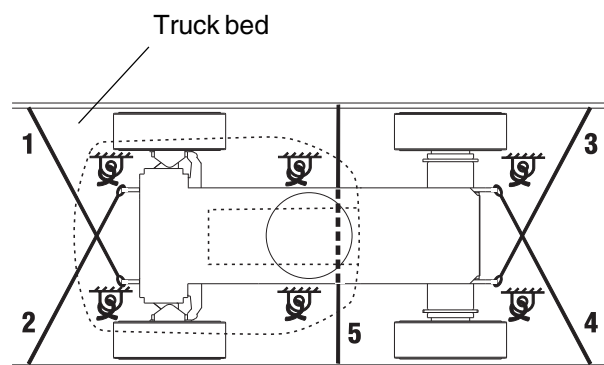

Securing the Platform

Place a block under the platform rotator. Do not allow the block to contact the platform cylinder.

Secure the platform with a nylon strap placed through the lower platform support. Do not use excessive downward force when securing the boom section.

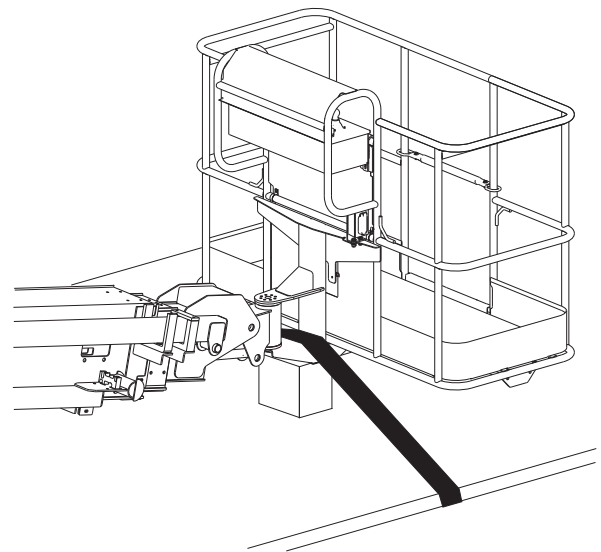

Transport and Lifting Instructions



Observe and Obey:

- ☑ Only qualified riggers should rig and lift the machine.
- ☑ Be sure the crane capacity, loading surfaces and straps or lines are sufficient to withstand the machine weight. See the serial label for the machine weight.

Lifting Instructions

Fully lower and retract the boom. Move the jib boom parallel with the ground. Remove all loose items on the machine.

Use the turntable rotation lock to secure the turntable.

Determine the center of gravity of your machine using the table and the picture on this page.

Attach the rigging only to the designated lifting points on the machine. There are two lifting points on the chassis and two on the turntable.

Adjust the rigging to prevent damage to the machine and to keep the machine level.

	X Axis	Y Axis
S-60 High Capacity Boom	70.2 in 1.78 m	51.7 in 1.31 m

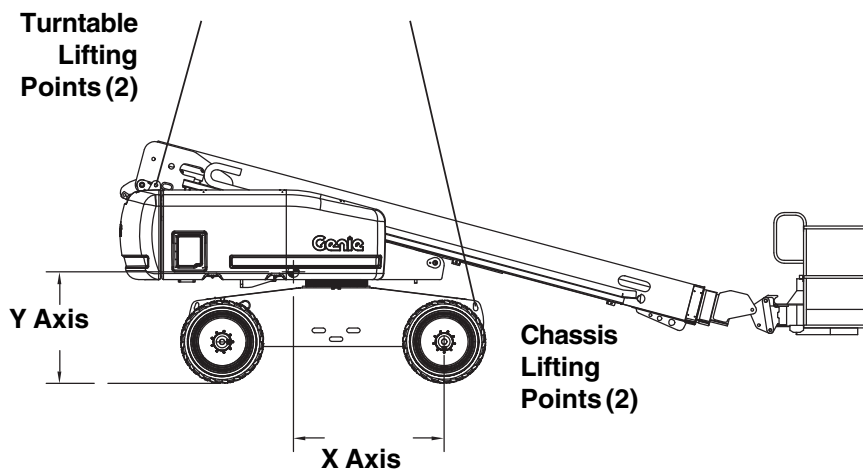

Maintenance



Observe and Obey:

- Only routine maintenance items specified in this manual shall be performed by the operator.
- Scheduled maintenance inspections shall be completed by qualified service technicians, according to the manufacturer's specifications and the requirements specified in the responsibilities manual.

Maintenance Symbols Legend

The following symbols have been used in this manual to help communicate the intent of the instructions. When one or more of the symbols appear at the beginning of a maintenance procedure, it conveys the meaning below.



Indicates that tools will be required to perform this procedure.



Indicates that new parts will be required to perform this procedure.



Indicates that a cold engine is required before performing this procedure.

Check the Engine Oil Level



Maintaining the proper engine oil level is essential to good engine performance and service life. Operating the machine with an improper oil level can damage engine components.

Note: Check the oil level with the engine off.

- 1 Check the oil dipstick. Add oil as needed.

Perkins 404-22 Engine

Oil type	15W-40
Oil type - cold conditions	5W-40

Ford DSG-423 EFI Engine (EPA Compliant)

Oil type	5W-20
Oil type - cold conditions	

Deutz F3L 2011F Engine

Oil type	15W-40
Oil type - cold conditions	5W-30

Maintenance

Check the Hydraulic Oil Level



Maintaining the hydraulic oil at the proper level is essential to machine operation. Improper hydraulic oil levels can damage hydraulic components. Daily checks allow the inspector to identify changes in oil level that might indicate the presence of hydraulic system problems.

- 1 Be sure that the boom is in the stowed position, then visually inspect the sight gauge located on the side of the hydraulic oil tank. Add oil as needed.
- ⊙ Result: The hydraulic oil level should be within the top 2 inches / 5 cm of the sight gauge.

Hydraulic oil specifications

Hydraulic oil type	Chevron Rykon Premium MV equivalent
--------------------	--

Check the Engine Coolant Level - Liquid Cooled Models



Maintaining the engine coolant at the proper level is essential to engine service life. Improper coolant level will affect the engine's cooling capability and damage engine components. Daily checks will allow the inspector to identify changes in coolant level that might indicate cooling system problems.

⚠ Burn hazard. Beware of hot engine parts and coolant. Contact with hot engine parts and/or coolant may cause severe burns.

- 1 Check the fluid level in the coolant recovery tank. Add fluid as needed.
- ⊙ Result: The fluid level should be at the FULL mark.

Note: Do not remove the radiator cap.

Maintenance

Check the Batteries



Proper battery condition is essential to good engine performance and operational safety. Improper fluid levels or damaged cables and connections can result in engine component damage and hazardous conditions.

⚠ Electrocution hazard. Contact with hot or live circuits may result in death or serious injury. Remove all rings, watches and other jewelry.

⚠ Bodily injury hazard. Batteries contain acid. Avoid spilling or contacting battery acid. Neutralize battery acid spills with baking soda and water.

- 1 Put on protective clothing and eye wear.
- 2 Be sure that the battery cable connections are tight and free of corrosion.
- 3 Be sure that the battery hold-down brackets are in place and secure.
- 4 Remove the battery vent caps.
- 5 Check the battery acid level. If needed, replenish with distilled water to the bottom of the battery fill tube. Do not overfill.
- 6 Install the vent caps.

Note: Adding terminal protectors and a corrosion preventative sealant will help eliminate corrosion on the battery terminals and cables.

Check the Tire Pressure



Note: This procedure does not need to be performed on machines equipped with foam-filled tires.

⚠ Bodily injury hazard. An over-inflated tire can explode and could cause death or serious injury.

⚠ Tip-over hazard. Do not use temporary flat tire repair products.

To safeguard maximum stability, achieve optimum machine handling and minimize tire wear, it is essential to maintain proper pressure in all air-filled tires.

- 1 Check each tire with an air pressure gauge. Add air as needed.

Tire pressure	70 psi	4.92 bar
----------------------	--------	----------

Maintenance

Scheduled Maintenance

Maintenance performed quarterly, annually and every two years must be completed by a person trained and qualified to perform maintenance on this machine according to the procedures found in the service manual for this machine.

Machines that have been out of service for more than three months must receive the quarterly inspection before they are put back into service.

Specifications

Model	S-60 High Capacity Boom	
Height, working maximum	64 ft 4 in	19.78 m
Height, platform maximum	58 ft 4 in	17.78 m
Height, stowed maximum	8 ft 11 in	2.72 m
Horizontal reach maximum Unrestricted range of motion	50 ft 10 in	15.48 m
Horizontal reach maximum Restricted range of motion	38 ft 11 in	11.86 m
Width	8 ft 2 in	2.3 m
Length, stowed	27 ft 11 in	8.51 m
Maximum load capacity Unrestricted range of motion	750 lbs	340 kg
Maximum load capacity Restricted range of motion	1250 lbs	567 kg
Maximum wind speed	28 mph	12.5 m/s
Wheelbase	8 ft 2.5 in	2.50 m
Turning radius (outside)	18 ft 2 in	5.5 m
Turning radius (inside)	7 ft 9 in	2.4 m
Turntable rotation (degrees)	continuous	
Turntable tailswing	4 ft	1.22 m
Controls	12V DC proportional	
AC outlet in platform	standard	
Platform dimensions, 6 foot (length x width)	72 in x 30 in	1.8 m x 76 cm
Platform dimensions, 8 foot (length x width)	96 in x 36 in	2.4 m x 91 cm
Drive speeds		
Drive speed, stowed, 2WD	4.0 mph 40 ft/6.8 sec	6.4 km/h 12.2 m/6.8 sec
Drive speed, stowed, 4WD	3.0 mph 40 ft/9 sec	4.8 km/h 12.2 m/9 sec
Drive speed, raised or extended	0.6 mph 40 ft/40 sec	1.0 km/h 12.2 m/40 sec

Continuous improvement of our products is a Genie policy. Product specifications are subject to change without notice or obligation.

Platform leveling	self-leveling	
Platform rotation	160°	
Hydraulic pressure, maximum	3000 psi	207 bar
Boom functions		
System voltage	12V	
Tire size	IN355/55 D625	
Ground clearance	14.5 in	36.8 cm
Fuel tank capacity	40 gallons	151 liters
Weight (Machine weights vary with option configurations)	See Serial Label	
Airborne noise emissions Maximum sound level at normal operating workstations (A-weighted)	105 dB	

Maximum slope rating, stowed position, 2WD

Counterweight uphill	30% (17°)
Counterweight downhill	10% (6°)
Side slope	25% (14°)

Maximum slope rating, stowed position, 4WD

Counterweight uphill	45% (24°)
Counterweight downhill	30% (17°)
Side slope	25% (14°)

Note: Slope rating is subject to ground conditions and adequate traction.

Floor loading information

Tire load, maximum	11,200 lbs	5080 kg
Tire contact pressure	70 psi	4.92 kg/cm ² 483 kPa
Occupied floor pressure	263 psf	1284 kg/m ² 12.6 kPa

Note: Floor loading information is approximate and does not incorporate different option configurations. It should be used only with adequate safety factors.

Specifications

S-60 High-Capacity Boom Range of Motion Chart

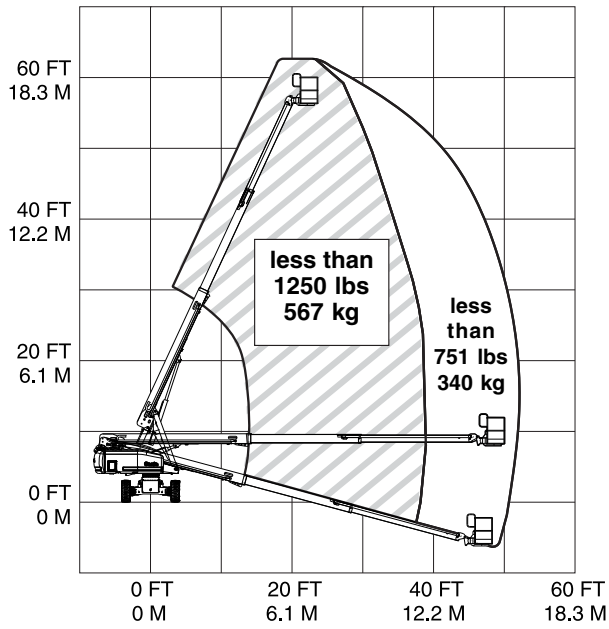

California Proposition 65

Warning

The exhaust from this product contains chemicals known to the State of California to cause cancer, birth defects or other reproductive harm.

Genie North America

Phone 425.881.1800
Toll Free USA and Canada
800.536.1800
Fax 425.883.3475

Genie Australia Pty Ltd.

Phone +61 7 3375 1660
Fax +61 7 3375 1002

Genie China

Phone +86 21 53852570
Fax +86 21 53852569

Genie Malaysia

Phone +65 98 480 775
Fax +65 67 533 544

Genie Japan

Phone +81 3 3453 6082
Fax +81 3 3453 6083

Genie Korea

Phone +82 25 587 267
Fax +82 25 583 910

Genie Brasil

Phone +55 11 41 665 755
Fax +55 11 41 665 754

Genie Holland

Phone +31 183 581 102
Fax +31 183 581 566

Genie Scandinavia

Phone +46 31 575100
Fax +46 31 579020

Genie France

Phone +33 (0)2 37 26 09 99
Fax +33 (0)2 37 26 09 98

Genie Iberica

Phone +34 93 579 5042
Fax +34 93 579 5059

Genie Germany

Phone +49 (0)4202 88520
Fax +49 (0)4202 8852-20

Genie U.K.

Phone +44 (0)1476 584333
Fax +44 (0)1476 584334

Genie Mexico City

Phone +52 55 5666 5242
Fax +52 55 5666 3241

Distributed By: