

hobbyzone®

Instruction Manual
Bedienungsanleitung
Manuel d'utilisation
Manuale di Istruzioni

AeroScout™

1.1 Meter SAFE® Trainer

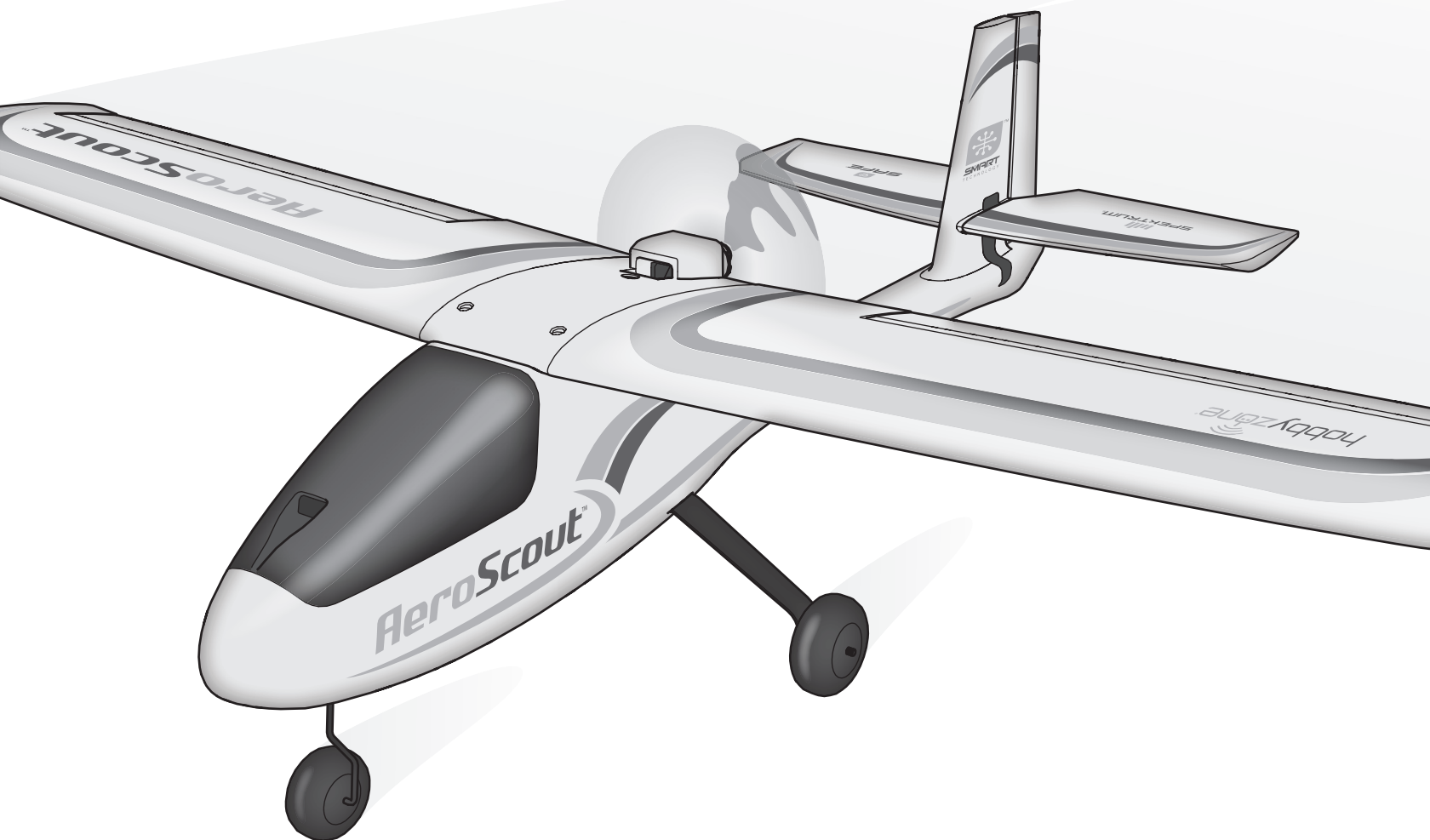

SAFE®

RTF
READY-TO-FLY

BNF
BASIC

HORIZON
H O B B Y

NOTICE

All instructions, warranties and other collateral documents are subject to change at the sole discretion of Horizon Hobby, LLC. For up-to-date product literature, visit www.horizonhobby.com or www.towerhobbies.com and click on the support or resources tab for this product.

Meaning of Special Language:

The following terms are used throughout the product literature to indicate various levels of potential harm when operating this product:

WARNING: Procedures, which if not properly followed, create the probability of property damage, collateral damage, and serious injury OR create a high probability of superficial injury.

CAUTION: Procedures, which if not properly followed, create the probability of physical property damage AND a possibility of serious injury.

NOTICE: Procedures, which if not properly followed, create a possibility of physical property damage AND little or no possibility of injury.

 **WARNING:** Read the ENTIRE instruction manual to become familiar with the features of the product before operating. Failure to operate the product correctly can result in damage to the product, personal property and cause serious injury.

This is a sophisticated hobby product. It must be operated with caution and common sense and requires some basic mechanical ability. Failure to operate this Product in a safe and responsible manner could result in injury or damage to the product or other property. This product is not intended for use by children without direct adult supervision. Do not use with incompatible components or alter this product in any way outside of the instructions provided by Horizon Hobby, LLC. This manual contains instructions for safety, operation and maintenance. It is essential to read and follow all the instructions and warnings in the manual, prior to assembly, setup or use, in order to operate correctly and avoid damage or serious injury.

14+ AGE RECOMMENDATION: Not for children under 14 years. This is not a toy.

Safety Precautions and Warnings

As the user of this product, you are solely responsible for operating in a manner that does not endanger yourself and others or result in damage to the product or the property of others.

- Always keep a safe distance in all directions around your model to avoid collisions or injury. This model is controlled by a radio signal subject to interference from many sources outside your control. Interference can cause momentary loss of control.
- Always operate your model in open spaces away from full-size vehicles, traffic and people.
- Always carefully follow the directions and warnings for this and any optional support equipment (chargers, rechargeable battery packs, etc.).
- Always keep all chemicals, small parts and anything electrical out of the reach of children.
- Always avoid water exposure to all equipment not specifically designed and protected for this purpose. Moisture causes damage to electronics.
- Never place any portion of the model in your mouth as it could cause serious injury or even death.
- Never operate your model with low transmitter batteries.
- Always keep aircraft in sight and under control.
- Always use fully charged batteries.
- Always keep transmitter powered on while aircraft is powered.
- Always remove batteries before disassembly.
- Always keep moving parts clean.
- Always keep parts dry.
- Always let parts cool after use before touching.
- Always remove batteries after use.
- Always ensure failsafe is properly set before flying.
- Never operate aircraft with damaged wiring.
- Never touch moving parts.

 **WARNING AGAINST COUNTERFEIT PRODUCTS:** If you ever need to replace your Spektrum receiver found in a Horizon Hobby product, always purchase from Horizon Hobby, LLC or a Horizon Hobby authorized dealer to ensure authentic high-quality Spektrum product. Horizon Hobby, LLC disclaims all support and warranty with regards, but not limited to, compatibility and performance of counterfeit products or products claiming compatibility with DSM or Spektrum technology.

If you own this product, you may be required to register with the FAA.

For up-to-date information on how to register with the FAA, please visit <https://registermyuas.faa.gov/>.

For additional assistance on regulations and guidance on UAS usage, visit knowbeforeyoufly.org/.

Box Contents

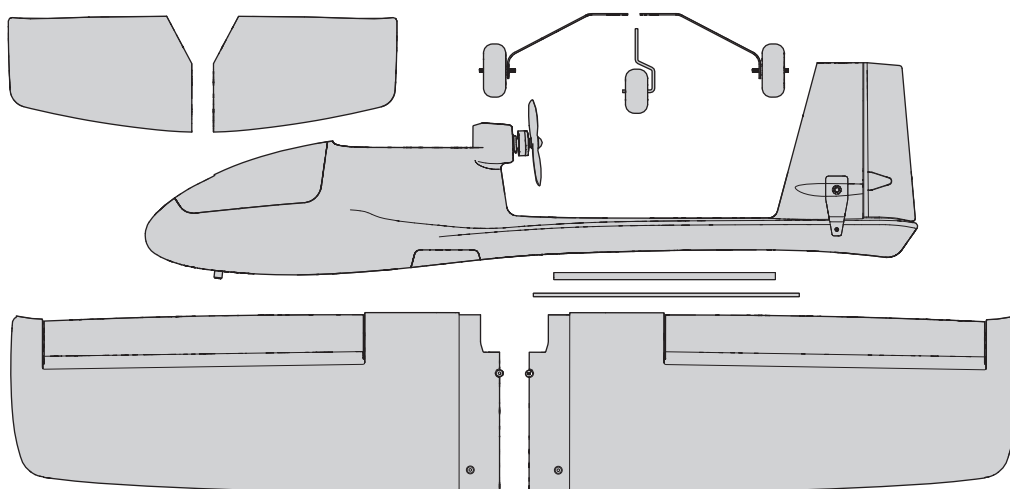
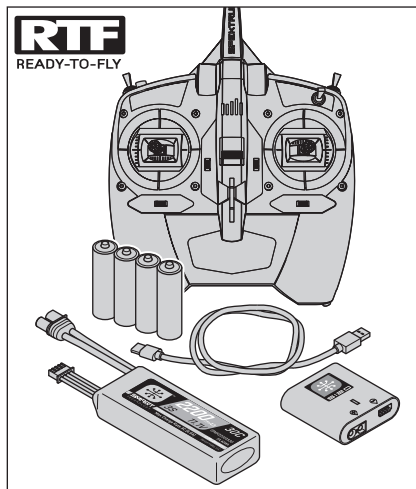
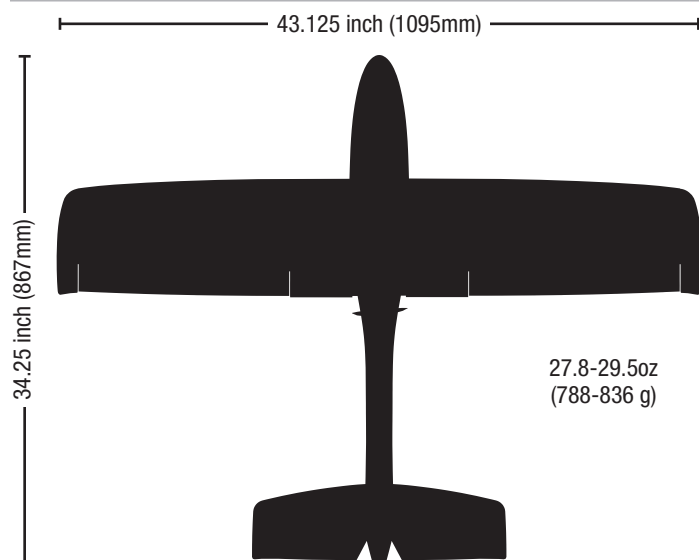

Table of Contents

Specifications	3	Flying	14
Charging Warnings.....	4	Trimming the Aircraft	15
Charge the Flight Battery	4	Post Flight Checklist	16
Transmitter Setup	5	Factory Settings for the Control Horns and Servo Arms	16
Included DXe Transmitter (RTF Version)	6	Service and Repairs.....	16
Assemble the Aircraft.....	7	AS3X® System Trouble Shooting Guide.....	17
Transmitter and Receiver Binding.....	9	Trouble Shooting Guide	17
Install the Flight Battery	9	Replacement Parts List	18
Center of Gravity (CG)	10	Optional Parts List.....	18
Control Direction Test.....	10	Limited Warranty	18
Choose a Flying Field	11	Contact Information	19
Range Test.....	11	FCC Information.....	19
Install the Propeller	12	IC Information.....	20
Sensor Assisted Flight Envelope (SAFE) Technology Flight Modes.....	12	Compliance Information for the European Union.....	20
Flight Control	13	AMA National Model Aircraft Safety Code	21
Preflight Checklist.....	14		

Specifications



	RTF READY-TO-FLY	BNF BASIC
Motor: 2306-2250 Brushless outrunner (HBZ3809)	Installed	Installed
ESC: 30A (HBZ3808)	Installed	Installed
Servos: 8g Servo (SPMSS390)	Installed	Installed
Receiver: AR636 6 channel AS3X® Sport Receiver (SPMAR636)	Installed	Installed
Battery: SMART 2200mAh 3S 11.1V 30C LiPo; IC3™ (SPMX22003S30)	Included	Required to Complete
Battery Charger: S120 USB-C SMART Charger, 1x20W (SPMXC1020)	Included	Required to Complete
Transmitter: Spektrum™ DXe with full range DSMX® technology	Included	Required to Complete

Charging Warnings

CAUTION: All instructions and warnings must be followed exactly. Mishandling of Li-Po batteries can result in a fire, personal injury, and/or property damage.

- **NEVER LEAVE CHARGING BATTERIES UNATTENDED.**
- **NEVER CHARGE BATTERIES OVERNIGHT.**
- By handling, charging or using the included Li-Po battery, you assume all risks associated with lithium batteries.
- If at any time the battery begins to balloon or swell, discontinue use immediately. If charging or discharging, discontinue and disconnect. Continuing to use, charge or discharge a battery that is ballooning or swelling can result in fire.
- Always store the battery at room temperature in a dry area for best results.
- Always transport or temporarily store the battery in a temperature range of 40–120° F (5–49° C). Do not store battery or aircraft in a car or direct sunlight. If stored in a hot car, the battery can be damaged or even catch fire.
- Always charge batteries away from flammable materials.

- Always inspect the battery before charging and never charge dead or damaged batteries.
- Always disconnect the battery after charging, and let the charger cool between charges.
- Always constantly monitor the temperature of the battery pack while charging.
- **ONLY USE A CHARGER SPECIFICALLY DESIGNED TO CHARGE LI-PO BATTERIES.** Failure to charge the battery with a compatible charger may cause fire resulting in personal injury and/or property damage.
- Never discharge Li-Po cells to below 3V under load.
- Never cover warning labels with hook and loop strips.
- Never charge batteries outside recommended levels.
- Never attempt to dismantle or alter the charger.
- Never allow minors under the age of 14 to charge battery packs.
- Never charge batteries in extremely hot or cold places (recommended between 40–120° F or 5–49° C) or place in direct sunlight.

Charge the Flight Battery

The recommended battery for the HobbyZone® AeroScout™ S aircraft, included with the RTF version, is an 11.1V, 2200mAh 3S 30C Smart Technology LiPo battery with an IC3™ connector (SPMX22003S30). If using a different battery, the battery should be of similar capacity, dimensions and weight to fit in the fuselage. The aircraft electronic speed control is equipped with an IC3 device connector. Ensure the battery chosen is compatible. Always ensure the model balances at the recommended center of gravity (CG) with the chosen battery. Follow your chosen battery and battery charger instructions to charge the flight battery.

RTF Smart Technology Battery and S120 Charger, Specifications and Operation

The Spektrum S120 SMART Technology battery charger included with the RTF version of the aircraft is compatible only with Spektrum SMART 2-3 cell LiPo batteries or 6-7 cell NiMH batteries. It is not compatible with any other battery chemistries or non-SMART batteries.

A USB power supply is required for use. A USB-C QC type power supply is recommended for the fastest charge times.

S120 Specifications	
Input	USB Type C, power supply not included
Input Voltage	5V-12V
Charge Power	18W max (dependant on power supply)
Compatible USB Power Adaptor	5V/1A, 5V/2A, USB Quick Charge (QC) 2.0/3.0
Battery Connector	IC3™ and balance connector
Battery Types	LiPo, NiMH (<i>Spektrum SMART Batteries only</i>)
Cell Count	2-3 cell LiPo, 6-7 cell NiMH
Max Output Voltage	13.05V
Max Output Current	Up to 2A

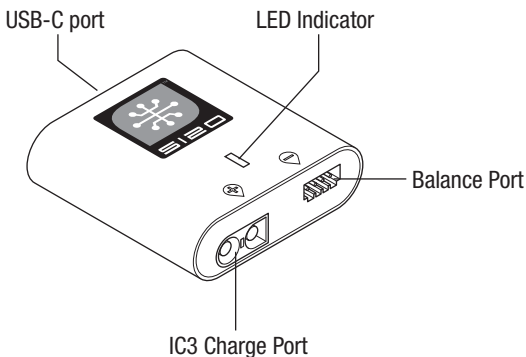

To charge the included flight battery:

1. Using the supplied Type-C USB cable, connect the S120 charger to a USB power supply (*not included*).

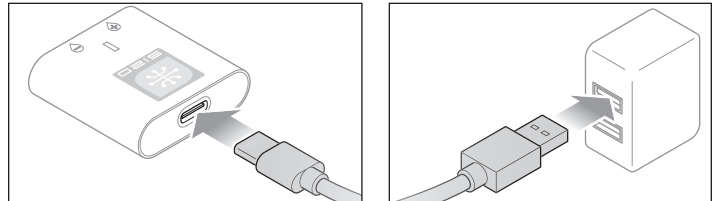

2. Insert the Spektrum SMART Battery IC3 connector (A) into the charger IC3 port, and insert the battery balance lead (B) into the charger balance port. Both the IC3 and balance connectors must be connected for the charging process to begin.

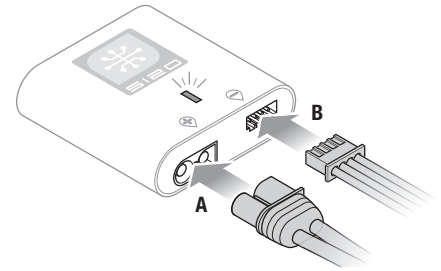

The battery may be disconnected from the charger at any time to stop the charging process.

IMPORTANT: SMART NiMH batteries do not have a balance connector.

3. Disconnect the IC3 and balance connectors when the charge and balance cycles are complete, as indicated by the LED.
4. The LED indicator will glow solid red to indicate a charging error. Follow the operation steps to ensure proper connection is used to charge the battery.

Refer to the LED indicator table for charger status.

IMPORTANT: Connecting a non-SMART battery will cause a charge error and the S120 will not recognize or charge the battery.

LED Indicator		
Power On	USB 5V: White LED	
	USB Quick Charge 2.0/3.0: Blue LED	
LiPo: Purple LED NiMH: Yellow LED	Battery Capacity	
	Less Than 25%	Single Flash
	25% – 75%	Double Flash
	76% – 99%	Triple Flash
Charge Complete	Green LED (Solid)	
Error	Red LED (Solid)	



⚠ WARNING: Before proceeding further, remove the propeller and spinner from the motor shaft. Never attempt to program the radio components, assemble the aircraft or perform maintenance of any kind without removing the propeller. Serious injury could result if the motor starts inadvertently with the propeller still attached.



1. Ensure the flight battery is NOT connected to the aircraft.
2. Hold the motor can firmly to keep it from rotating.
3. Twist the propeller and prop nut clockwise to loosen them from the motor shaft.
4. Remove the propeller, prop nut and prop washer.

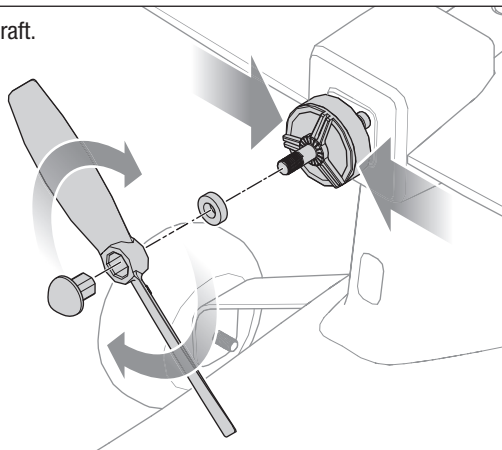

Transmitter Setup

If using any DSMX transmitter other than the included DXe (3 position gear switch, RTF only) the radio will have to be configured correctly for the SAFE system to work properly.

- SAFE Flight mode is selected using Channel 5 signal (high, middle, low)
- Panic mode is selected with Channel 6 signal (high, low)

Refer to your transmitter's manual for more information about transmitter setup. If using a 2 position switch for SAFE flight modes, only Beginner and Experienced modes will be active.

Any DXe Transmitter that was not included with a HBZ AeroScout RTF will need to be programmed using the Spektrum Programmer (SPMA3065) to function correctly with this aircraft. Visit www.spektrumrc.com to download the correct program for this aircraft.

Computerized Transmitter Setup (DX6 Gen2, DX6e, DX7 Gen2, DX8 Gen2, DX9, iX12, DX18 and DX20)	
Start all transmitter programming with a blank model (do a model reset), then name the model.	
Set Aileron, Elevator, and Rudder Rates to:	HIGH 100% LOW 70%
DX6 DX6e DX8 DX9 iX12 DX20	Go to the SYSTEM SETUP
	Set MODEL TYPE: AIRPLANE
	Go to CHANNEL ASSIGN: click NEXT to go to Channel Input Config: GEAR: B, AUX1: I
	Go to the FUNCTION LIST
	Go to Throttle Cut: set to Switch H, Position: -130
Resulting in:	Switch H operates Throttle Cut, position 0 is normal and position 1 cuts power to the throttle. Switch B operates the 3 SAFE Plus modes (0 beginner/1 intermediate/2 experienced). Button I operates PANIC mode.

Included DXe Transmitter (RTF Version)

Installing the Transmitter Batteries

Remove the battery cover, install the four included batteries (noting proper polarity) and reinstall the battery cover.

Low Battery Alarm

The LED indicator flashes and the transmitter beeps progressively faster as the battery voltage drops.

Replace the transmitter batteries when the transmitter begins to beep.

CAUTION: If using rechargeable batteries, charge only rechargeable batteries. Charging non-rechargeable batteries may cause the batteries to burst, resulting in injury to persons and/or damage to property.

WARNING: Do not pick up the transmitter by the antenna. Do not alter or put weight on the antenna. Damage to antenna parts can decrease transmitter signal strength, which can result in loss of model control, injury or property damage.

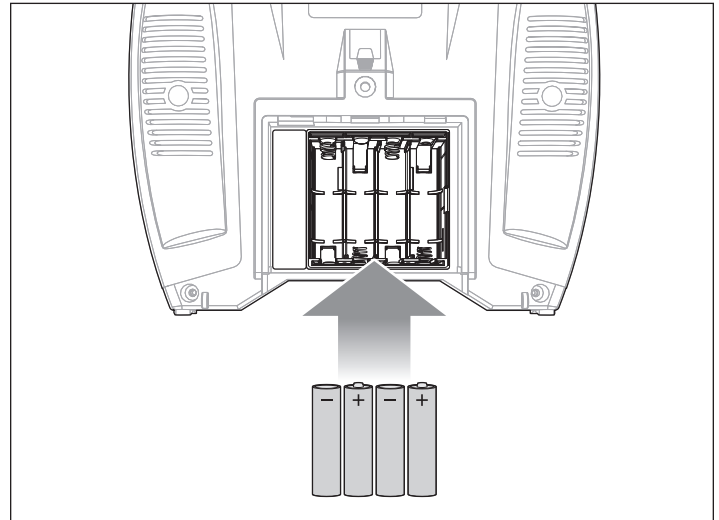

RTF Transmitter Control Layout

The diagram shows the control layout of the included DXe transmitter.

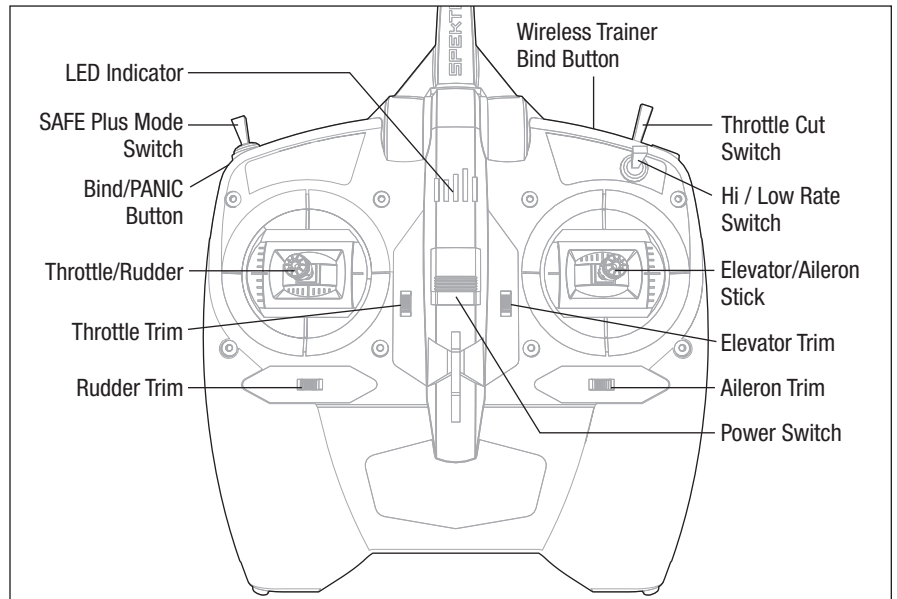

Assemble the Aircraft

Install the landing gear

1. Slide the main gear into the slots in the fuselage until they lock into place.

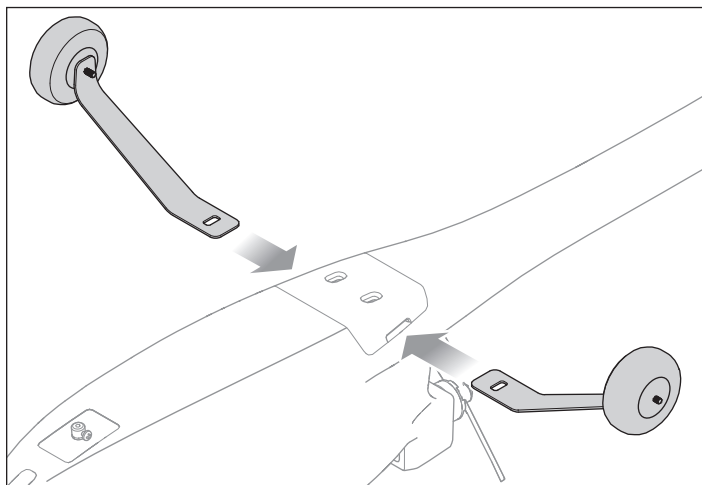

2. Insert the nose gear into the wheel collar as shown and tighten the setscrew against the flat in the gear wire using a phillips screwdriver.

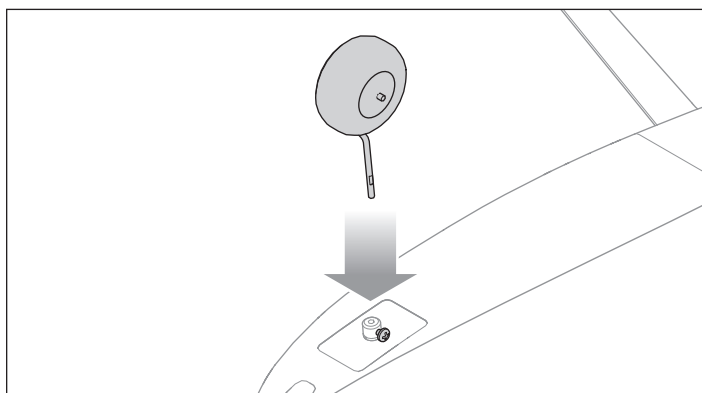

Install the horizontal tail

1. Slide the longer of the two included square carbon fiber tubes fully into the hole of either of the horizontal stabilizers. The tube is a compression fit and does not require any adhesive.

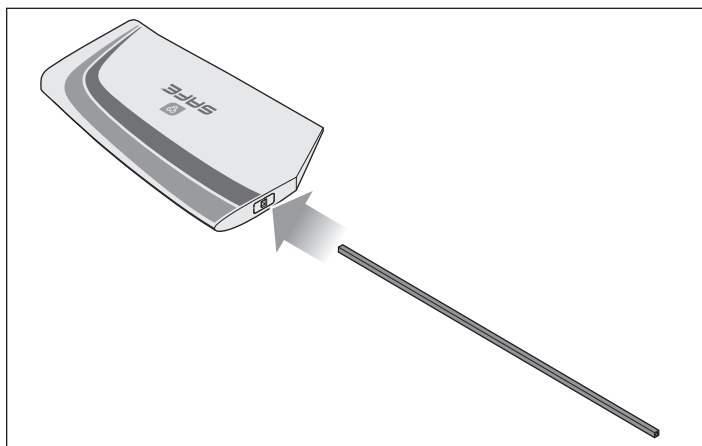

2. Insert the tube through the hole in the vertical tail of the fuselage as shown, until the previously attached horizontal stabilizer is against the fuselage.

IMPORTANT: The decals on the horizontal stabilizers must face up when the stabilizers are installed correctly.

3. Slide the opposite horizontal stabilizer over the other end of the tube. Press the stabilizer halves together until they are both fully seated on the tube and there is just a small gap between the stabilizers and the fuselage.

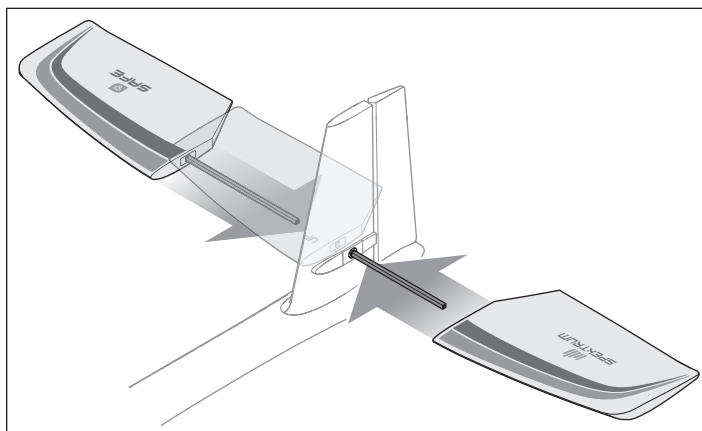

Assemble and install the wing

1. Slide the carbon fiber wing spar fully into a wing panel as shown. Ensure the aileron servo lead exits through the slot in the bottom of the wing.

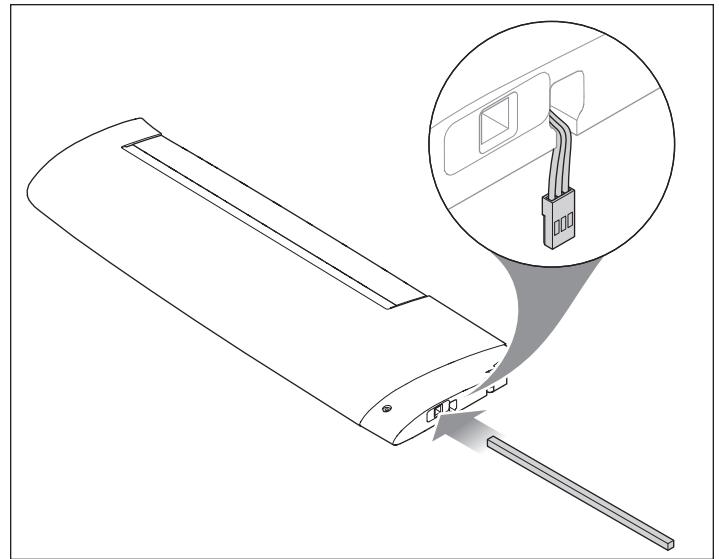

2. Slide the opposite wing panel over the wing spar until the root of the wing panels are tight and the rear mounting hole is correctly aligned. Ensure both aileron servo leads exit through the bottom of the wing and are not pinched between the wing panels.

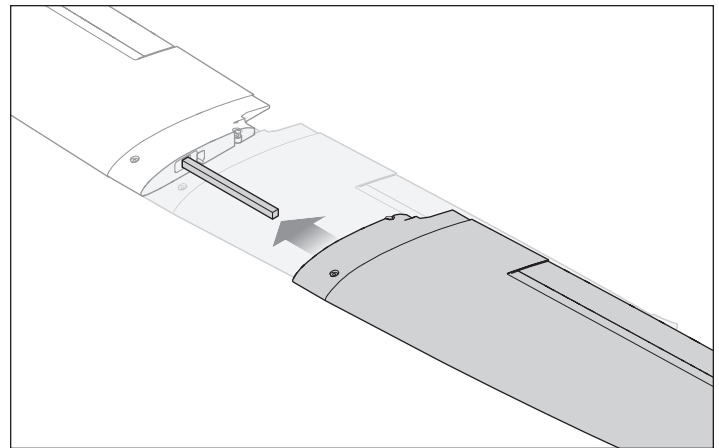

3. Connect the aileron servo leads to the y-harness installed in channel 2 of the receiver.

4. Center the wing on the fuselage. Ensure the aileron leads are not pinched between the wing and fuselage.

5. Attach the wing with the included 50mm screws. Do not overtighten the wing screws, as it may damage the wing or the attachment points in the fuselage.

IMPORTANT: The wing screws may be a tight fit the first few times they are installed into the fuselage. Use a screwdriver if necessary until the fuselage attachment points loosen up enough for the screws to be installed by hand.

NOTICE: Do not overtighten the wing screws. Doing so will crush the foam of the wing or damage the fuselage attachment points.

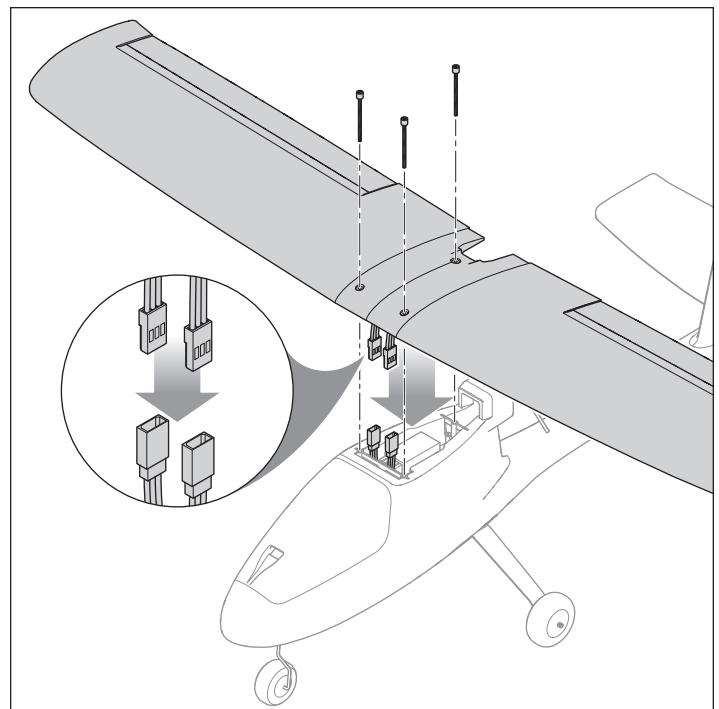

Transmitter and Receiver Binding

CAUTION: Connecting the battery to the ESC with reversed polarity will cause damage to the ESC, the battery or both. Damage caused by incorrectly connecting the battery is not covered under warranty.

An extension is installed in the receiver bind port so binding may be done through the battery hatch at the front of the aircraft without having to remove the wing assembly. Simply insert the bind plug in the open end of the extension to enter bind mode.

The transmitter included with the RTF model is bound to the aircraft at the factory. If you need to re-bind for any reason, follow the binding procedure as shown.

The BNF version of this aircraft requires a Spektrum™ DSM2®/DSMX® technology equipped aircraft transmitter for proper operation.

Refer to your transmitter instructions for binding to a receiver.

If you encounter problems after following the binding instructions, contact the appropriate Horizon Product Support office.

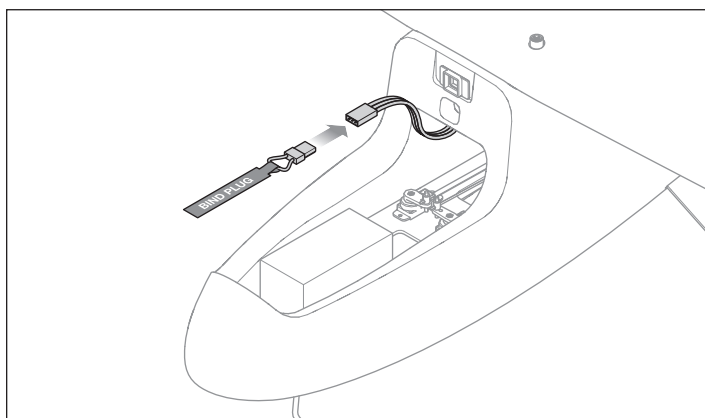

Binding Procedure

1. Make sure the transmitter is powered off.
2. Make sure the transmitter controls are neutral, the throttle is at the lowest position*, the throttle trim is centered and the aircraft is immobile.
3. Install a bind plug in the receiver bind port extension.
4. Connect the flight battery to the ESC. The ESC will produce three ascending tones and the receiver LED will begin to flash rapidly.
5. Refer to your transmitter manual for specific instructions to place the transmitter in bind mode.
6. When the receiver binds to the transmitter, the receiver LED will glow solid and the aircraft will begin the initialization process, indicated by the control surfaces cycling.
7. Remove the bind plug from the bind port extension and store in a safe place. The receiver should retain the binding instructions received from the transmitter until another binding is done.

* The throttle will not arm if the transmitter's throttle stick is not set to the lowest position.

Install the Flight Battery

1. Power on the transmitter.
2. Set the transmitter MOTOR switch to "DISARM".
3. Lift at the rear of the battery hatch to remove it from the fuselage.
4. Attach a piece of adhesive-back loop material to the bottom of the battery.
5. Place the battery, loop material down, on the battery tray. The placement of the battery can be adjusted forward or backward to help balance the aircraft.
6. When the battery is properly placed, secure it with the hook and loop strap.
7. Connect the IC3 battery connector to the ESC, noting proper polarity.

CAUTION: Connecting the battery to the ESC with reversed polarity will cause damage to the ESC, the battery or both. Damage caused by incorrectly connecting the battery is not covered under warranty.

CAUTION: Always keep hands away from the propeller. When armed, the motor will turn the propeller in response to any throttle movement.

8. Place the aircraft on a flat, level surface. The control surfaces will cycle as the SAFE system initializes. Initialization is complete when the surfaces stop moving.

9. Replace the battery hatch on the fuselage by first inserting the front tab then lowering the back until the magnet catches.

CAUTION: Always disconnect the Li-Po flight battery from the aircraft when not flying to avoid over-discharging the battery. Batteries discharged to a voltage lower than the lowest approved voltage may become damaged, resulting in loss of performance and potential fire when batteries are charged.

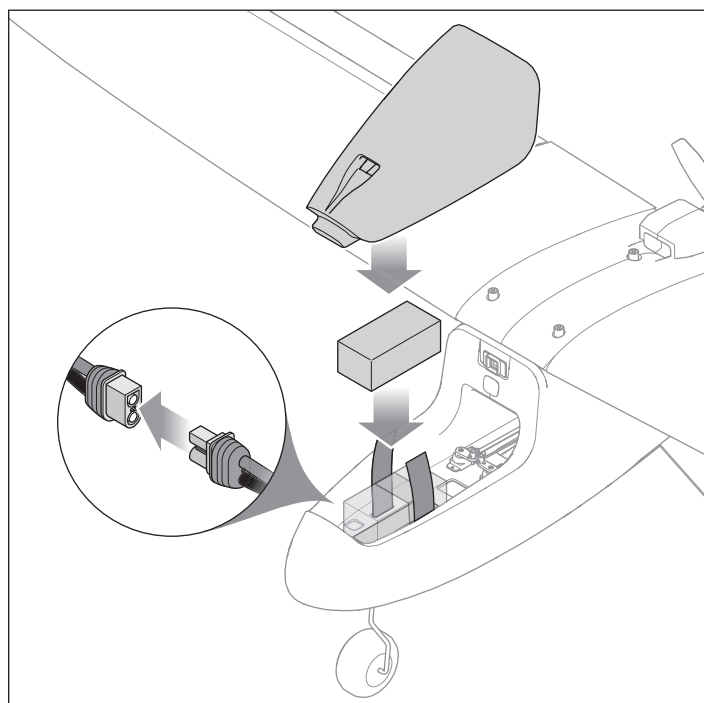

Center of Gravity (CG)

An aircraft with the correct CG has its weight balanced on the center of the aircraft for safe, stable flight. The aircraft CG and weight are based on having the recommended battery installed.

The CG location is 67-70mm back from the leading edge of the wing at the root and is marked on the *bottom* of the wing with a raised "CG". Balance the aircraft on your fingertips at the raised marks.

Adjust the battery position as needed get the aircraft to balance correctly.

- If the nose goes down, move the flight battery back until the aircraft balances.
- If the nose goes up, move the flight battery forward until the aircraft balances.

When in intermediate and experienced modes, if the aircraft CG is too far forward (nose heavy), up elevator is required to fly level at 50%-60% power. If the aircraft CG is too far aft (tail heavy), down elevator is required to fly level. In Beginner mode the aircraft is not affected. The SAFE Plus system controls the aircraft attitude.

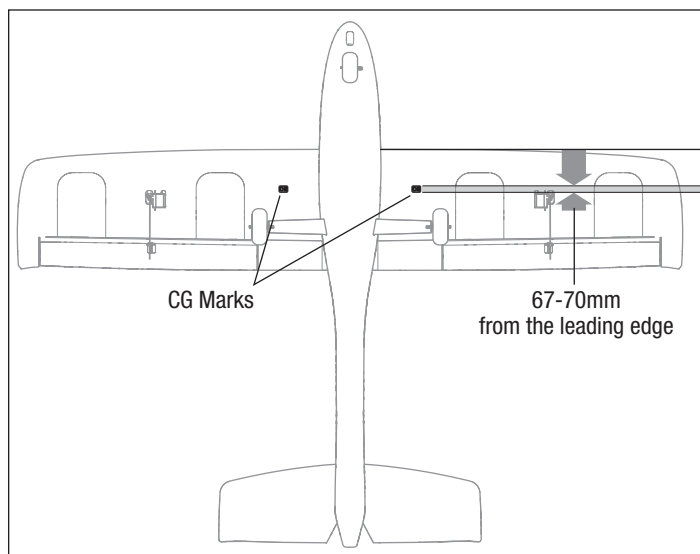

Control Direction Test

WARNING: Do not perform this or any other equipment test with the propeller installed on the aircraft. Serious injury or property damage could result from the motor starting inadvertently.

1. Set the flight mode switch to **Experienced mode** (position 2).
2. Keep the throttle at zero and place the model on level ground away from obstacles.
3. Move the sticks on the transmitter as described in the table to ensure the aircraft control surfaces respond as shown.

If the control surfaces do not respond as shown, **DO NOT FLY**. Refer to the *Troubleshooting Guide* for more information. If you need more assistance, contact the appropriate Horizon Hobby Product Support department.

If the aircraft responds as shown, continue on to the Flight Control section.

	Transmitter command	Control Surface Response
Elevator		
Aileron		
Rudder		

Choose a Flying Field

Consult local laws and ordinances before choosing a location to fly your aircraft.

In order to have the most success and to protect your property and aircraft, it is very important to select a place to fly that is very open.

Remember, your aircraft can reach significant speeds when flying and can cover ground quickly. Plan on flying in an area that gives you more space than you think you need, especially with first flights.

The flying site should:

- Have a minimum of approximately 1300 feet (400m) of clear space in all directions.
- Be clear of people and pets.
- Be free of trees, buildings, cars, power lines or anything that could entangle your aircraft or interfere with your line of sight.

Range Test

WARNING: Do not perform this or any other equipment test with the propeller installed on the aircraft. Serious injury or property damage could result from the motor starting inadvertently.

WARNING: While holding the aircraft during the range test, always keep body parts and loose items away from the motor. Failure to do so could cause personal injury.

Before each flying session, and especially with a new model, you should perform a range check. If you have the BNF aircraft, refer to your transmitter manual to perform a range check of your system.

The RTF included DXe transmitter incorporates a range check mode to reduce the output power of the transmitter. Follow the directions below to enter range check mode for the DXe transmitter:

1. Power on the transmitter for 5 seconds or more with the throttle stick and trim low. Plug in the aircraft battery and keep the aircraft immobile for 5 seconds.
2. Face the model with the transmitter in your normal flying position.
3. Toggle the HI/LO Rate switch rapidly 4 times and then press and hold the bind button. The transmitter LEDs will flash and the alarm will sound. The system is in range check mode. Do not let go of the bind button until you are finished with the range check.

IMPORTANT: You must hold the BIND/Panic button during the entire range check process. Releasing the button will exit the range check mode.

4. With the radio system powered on and the model restrained on the ground, stand 28 meters (90 feet) away from the model.

TIP: In some aircraft, when the model is placed on the ground, the antenna(s) can be within inches of the ground. Close proximity of the antenna(s) to the ground can reduce the effectiveness of the range check. If you experience issues during the range check, restrain the model on a non-conductive stand or table up to 2ft (60cm) above the ground, then range check the system again.

5. Move the transmitter rudder, elevator, aileron and throttle controls to ensure they operate smoothly at 28 meters (90 feet).
6. If control issues exist, do not attempt to fly. Refer to the contact table at the end of this manual to contact Horizon Hobby product support. Also, see the Spektrum website for more information.
7. When the range check is successfully completed, release the bind button to exit range check mode.

CAUTION: Due to reduced output power of the transmitter, NEVER attempt to fly while the transmitter is in range check mode. Loss of control will occur.

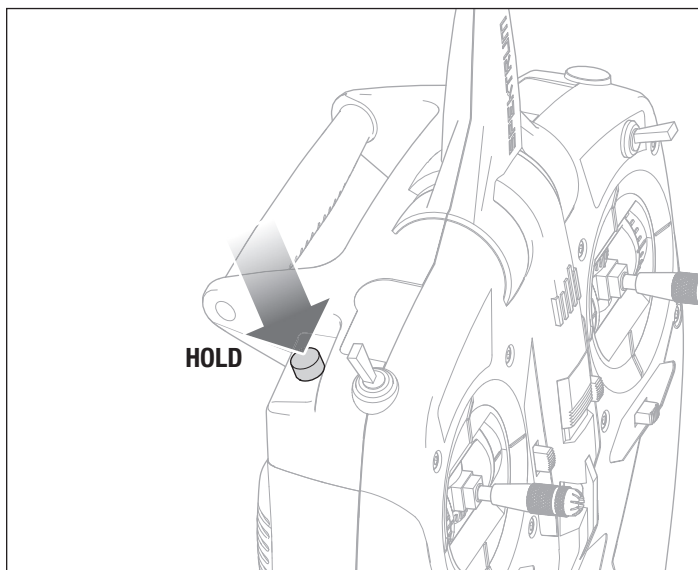
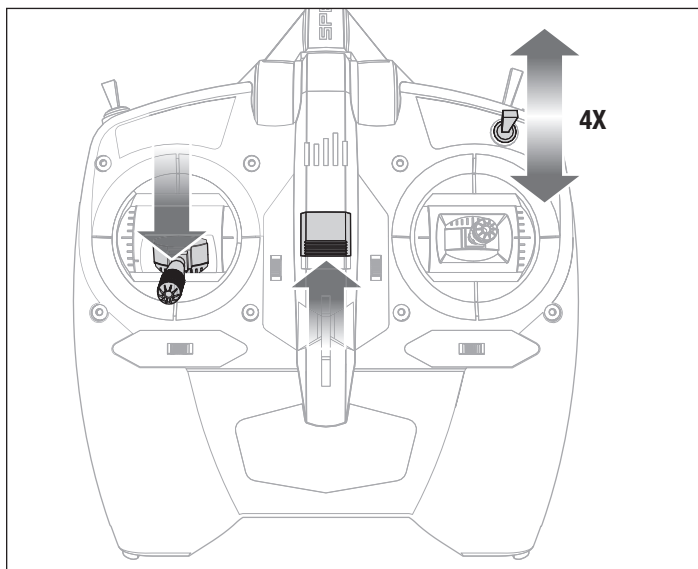

Install the Propeller

WARNING: Do not install the propeller until the aircraft has been completely assembled, all systems have been checked thoroughly and you are located at a suitable flying site.

Follow the instructions below to install the propeller and spinner:

1. Place the prop washer on the motor shaft.
2. Insert the prop nut in the propeller. The raised letters on the propeller should face away from the rounded head of the prop nut. When the propeller is installed, the raised letters should face toward the front of the aircraft.
3. Grip the motor can firmly to keep it from rotating.
4. Thread the propeller and prop nut onto the motor shaft.

IMPORTANT: The motor shaft and prop nut are reverse-threaded. Turn the prop nut counter-clockwise to tighten it to the motor shaft.

5. Tighten propeller and prop nut to the motor shaft by hand.

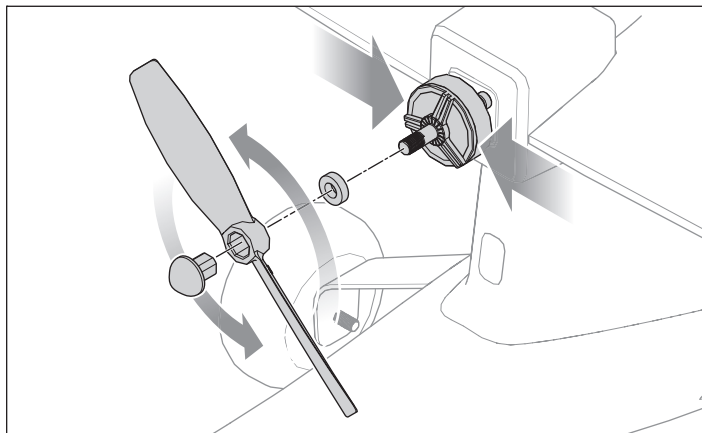

Sensor Assisted Flight Envelope (SAFE) Technology Flight Modes

At any time during a flight you can switch between the 3 flight modes or use Panic recovery to get your aircraft to a safe flying attitude. Change between flight modes by changing the flight mode switch position.

Beginner Mode (position 0)

- Envelope limit: Pitch (nose up and down) and Roll (wing tips up and down) angles are limited to help you keep the aircraft airborne.
- Self-leveling: when the pitch and roll controls are returned to neutral, the aircraft returns to level flight.
- Stability assisted takeoff and landing.
- Throttle based climb and descent.

Intermediate Mode (position 1)

- Natural Flight Experience: In normal training flight conditions, the pilot experiences natural AS3X® flight for smooth handling and outstanding precision.
- Large Flight Envelope: The pilot is only prevented from entering extreme flight conditions outside the training flight envelope.

Experienced Mode (position 2)

- Natural Flight Experience: The pilot experiences natural AS3X flight for smooth handling and outstanding precision.
- Unlimited Flight Envelope: No limit on Pitch and Roll angles (airframe limited).

Panic Recovery

This function is intended to provide you with the confidence to continue to improve your flight skills. If you become disoriented or the aircraft is in an unknown or uncomfortable attitude:

1. Press and hold the Bind/PANIC button on the transmitter and release the control sticks. The aircraft will immediately pull out of a dive and roll wings upright and level.

IMPORTANT: The aircraft will recover to a safer attitude even if sticks are held while holding the PANIC button. However, release the control sticks for the quickest recovery.

2. Release the PANIC button and continue a gentle climb to a safe altitude.

CAUTION: The Panic Recovery function will not avoid obstacles in the aircraft flight path. Sufficient altitude is required for the aircraft to return to straight and level flight if the aircraft is upside down when the panic function is applied.

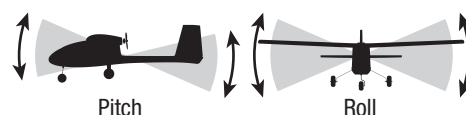
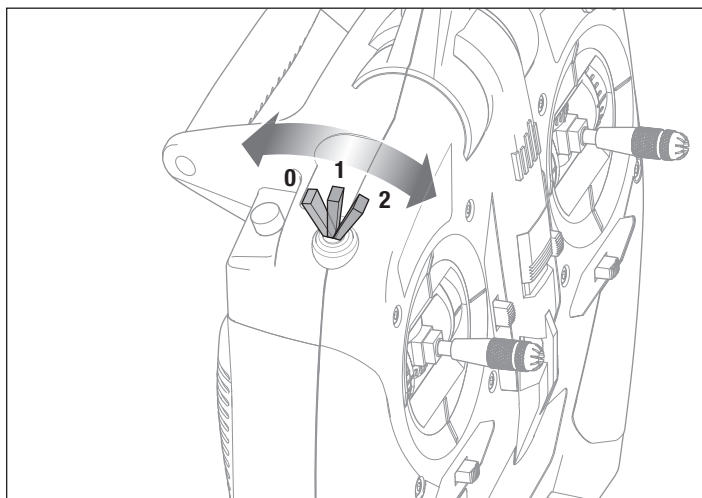

Beginner Mode
(Switch Position 0)

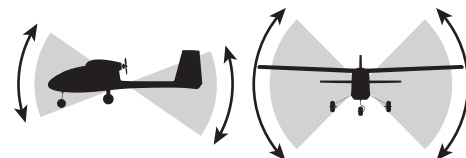

Intermediate Mode
(Switch Position 1)

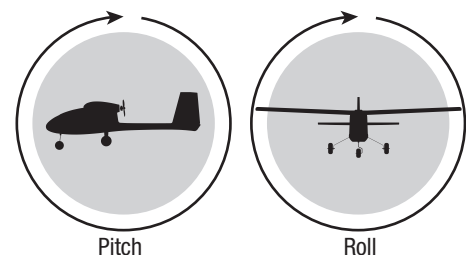

Experienced Mode
(Switch Position 2)

Flight Control

IMPORTANT: Even though SAFE technology is a very helpful tool, the aircraft still needs to be flown manually. If incorrect input is given at lower altitudes or at slower speeds, the aircraft can crash. Study these control inputs and the aircraft response to each carefully before attempting your first flight. For first flights, set the SAFE® flight mode switch to Beginner Mode (position 0). For smooth control of your aircraft, always make small corrections. All directions are described as if you were sitting in the aircraft.

Flying faster or slower: When your aircraft is stable in the air, push the throttle stick up to make the aircraft go faster. Pull the throttle stick back to slow down. The aircraft will climb when the throttle is increased.











Elevator up and down: Push the elevator stick forward to make the aircraft go down. Pull the elevator stick back to go up.

Aileron right and left: Move the aileron stick right to make the aircraft roll or “bank” right. Move the aileron stick left to bank left.

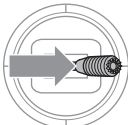
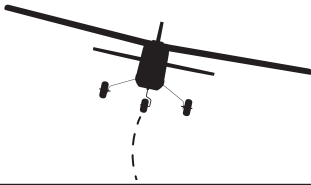
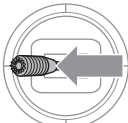
TIP: Always picture yourself in the aircraft when determining which way to bank the aircraft wings. When the aircraft is flying away from you, banking the aircraft right or left appears normal. When flying toward you, the aircraft will appear to bank the opposite direction to the control input given. This will become more instinctual with experience.

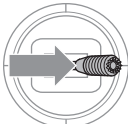
Rudder left and right: Push the rudder stick left or right to yaw or point the nose of the aircraft left or right. The rudder stick is also used to steer the aircraft left and right while taxiing on the ground.

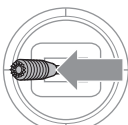
TIP: Similar to aileron control, picture yourself in the aircraft to determine which direction to point the nose whether you are flying away from yourself or toward yourself.

	Transmitter command	Aircraft Response
Elevator		
		
Aileron		
		
Rudder		
		

Preflight Checklist

1. Find a safe and open flying area
2. Charge flight battery
3. Install fully charged flight battery in aircraft
4. Make sure linkages move freely
5. Perform control direction test

6. Perform a range check
7. Plan flight for flying field conditions
8. Set a flight timer for 5-6 min.
9. Install the propeller
10. Have fun!

Flying

Takeoff

Set the flight mode switch to Beginner Mode (position 0) for your first flights. Set a flight timer for 5-6 minutes.

Ground Launch

Once the aircraft is ready for flight, slowly advance the throttle to start the takeoff roll into the wind. Small rudder inputs may be required for heading correction as the aircraft will begin a slow climb out as the throttle is advanced.

Hand Launch

Once the aircraft is ready for flight, use the following steps.

1. Grip the aircraft under the fuselage, behind the main gear.
2. Slowly advance the throttle to 100%.
3. Throw the aircraft slightly nose up and directly into the wind. Small rudder inputs may be required for heading correction as the aircraft will begin a slow climb out as the throttle is advanced.

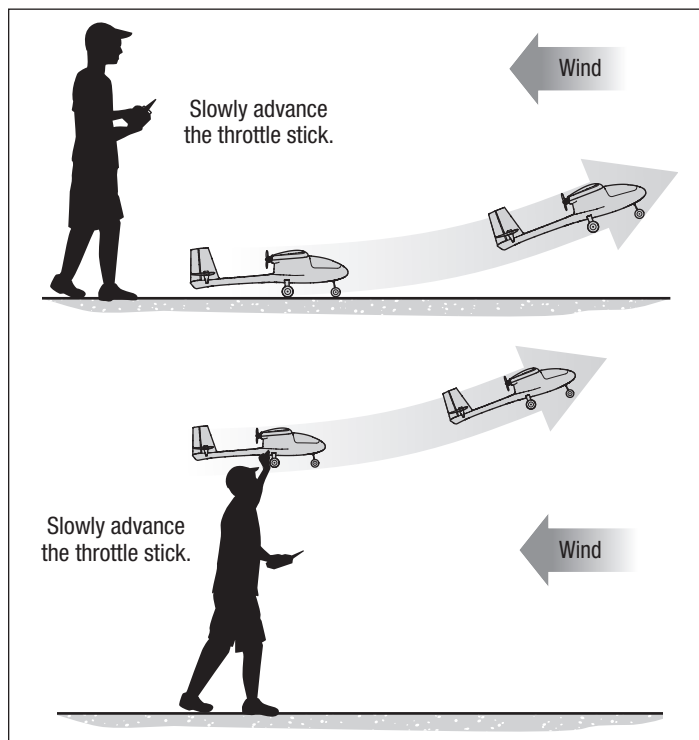

In Flight

Let the aircraft climb at full throttle, into the wind, until the aircraft gets about 300 feet (91m) above the ground, then decrease the throttle to half (50%). Make small and gentle stick movements to see how the aircraft responds. Flying with the nose pointed toward you is one of the hardest things to do when learning to fly. Practice flying in large circles high off the ground. If you lose orientation of the aircraft, press and hold the PANIC button and the aircraft will return to level flight.

NOTICE: If a crash is imminent, activate throttle hold or quickly lower the throttle and throttle trim. Failure to do so could result in extra damage to the airframe, as well as damage to the ESC and motor.

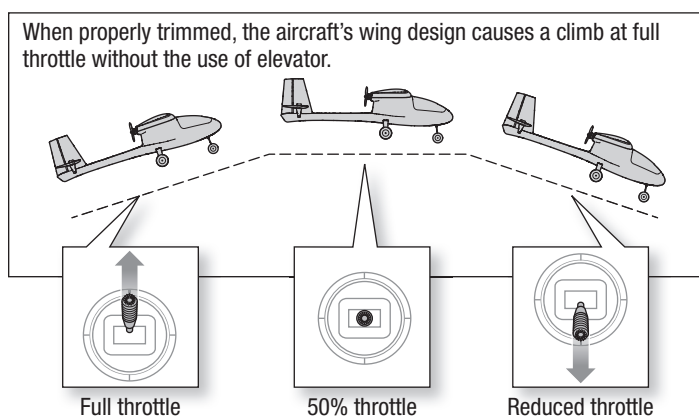

Low Voltage Cutoff (LVC)

LVC is a function built into your ESC to protect the battery from over-discharge. When the battery charge is low, LVC limits power supplied to the motor. The aircraft will begin to slow and you will hear the motor pulse. When the motor power decreases, land the aircraft immediately and recharge the flight battery.

NOTICE: Repeated flying to LVC will damage the battery.

Disconnect and remove the Li-Po battery from the aircraft after use to prevent trickle discharge. Charge your Li-Po battery to about half capacity before storage. During storage, make sure the battery charge does not fall below 3V per cell.

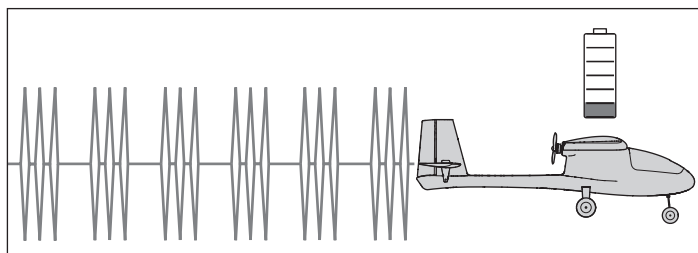

Landing

1. Reduce the throttle to around 50% to slow the airspeed.
2. Fly the aircraft downwind past the end of the runway.
3. Turn the aircraft into the wind and line the aircraft up with the runway center line.
4. Decrease the throttle further and begin descending towards the runway, keeping the wings level during approach. Try to have the aircraft at approximately 10ft (3m) altitude as it passes over the threshold of the runway.
5. As the aircraft passes over the threshold of the runway decrease the throttle fully.
6. Just as the aircraft is about to touch down, gently pull back on the elevator to raise the nose and flair for a gentle landing.

NOTICE: If a crash is imminent, activate throttle hold or quickly lower the throttle and throttle trim. Failure to do so could result in extra damage to the airframe, as well as damage to the ESC and motor.

IMPORTANT: When finished flying, never keep the aircraft in the sun. Do not store the aircraft in a hot, enclosed area such as a car. Doing so can damage the foam.

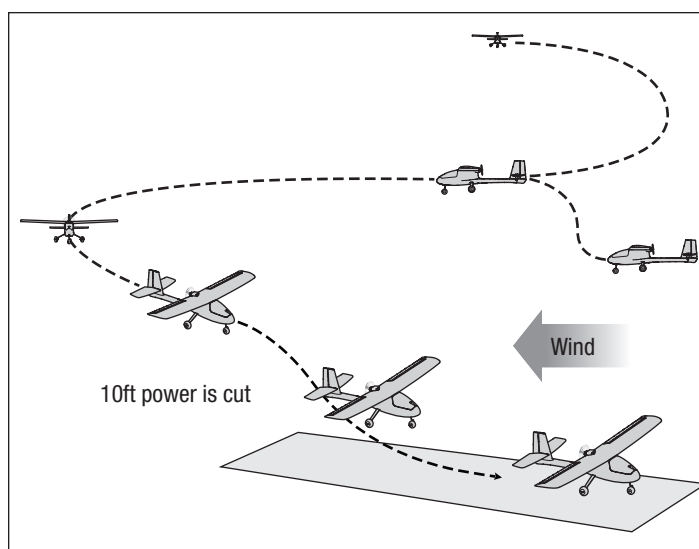

Trimming the Aircraft

Adjusting Trim in flight

If your aircraft does not fly straight and level at half throttle with the sticks at neutral, fly into the wind and adjust the trim sliders as indicated in the table until the aircraft maintains a reasonably straight and level flight path.

- Trimming is best done in calm wind conditions.
- The SAFE flight mode switch should be set to Experienced mode (position 2) before adjusting the trims.

After the aircraft is trimmed in flight, land the aircraft and proceed to the *Manually Adjusting Trim* section to set the trim mechanically.

The included RTF DXe transmitter features electronic trim buttons. The transmitter emits a faint beep with each click of the trim buttons in either direction. Holding the button in either direction quickly adjusts the trim several steps until the button is released or until the trim reaches the end of its travel. If the trim button does not beep when clicked, the trim is at the far end of its travel. Center trim is indicated by a slightly louder beep.

Manually Adjusting Trim

WARNING: Do not perform any maintenance with the propeller installed on the aircraft. Serious injury or property damage could result from the motor starting inadvertently.

The SAFE Plus flight mode switch should be set to Experienced mode (position 2) before manually adjusting the trim settings.

The aircraft should be kept still while performing manual adjustment of trim.

With the trim settings from the trim flight still set in the transmitter, take note of the positions of each of the control surfaces, one at a time.

Adjust the clevis on each control surface to position the surface the same as it was with the trim offset.

1. Remove the clevis from the control horn.
2. Turn the clevis (as shown) to lengthen or shorten the pushrod.
3. Close the clevis onto the control horn and slide the tube towards the horn to secure the clevis.
4. Move to the next control surface.

When you have all of the surface trims centered, return the trim settings on the transmitter to neutral by pushing the trim buttons for each surface until the transmitter emits a loud beep indicating center trim.

	Aircraft Drift	Trim Required
Elevator		 Elevator Trim
		 Elevator Trim
Aileron		 Aileron Trim
		 Aileron Trim
Rudder		 Rudder Trim
		 Rudder Trim

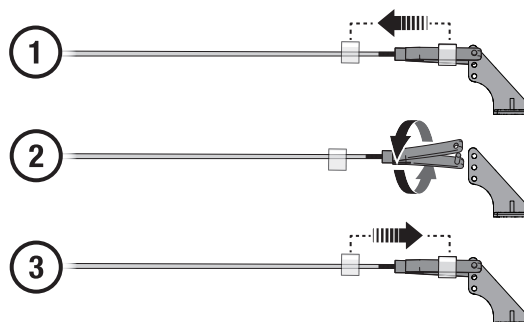

Post Flight Checklist

1. Activate Throttle Cut.	5. Inspect the airframe for loose or damaged parts
2. While avoiding the area of the propeller and prop arc, disconnect and remove the flight battery from the aircraft	6. Repair or replace all damaged parts
3. Power off the transmitter	7. Store flight battery apart from the aircraft and monitor the battery charge
4. Recharge the flight battery	8. Make note of flight conditions and flight plan results, planning for future flights

Factory Settings for the Control Horns and Servo Arms

The illustration shows recommended hole settings in the servo arms and control horns.

	Elevator	Ailerons	Rudder	Nose Wheel
Servo Arms				
Control Horns				

Service and Repairs

WARNING: Do not perform this or any other equipment maintenance with the propeller installed on the aircraft. Serious injury or property damage could result from the motor starting inadvertently.

NOTICE: Crash damage is not covered under warranty.

NOTICE: After any impact or replacement always ensure the receiver is secure in the fuselage. If you replace the receiver, install the new receiver in the same location and orientation as the original or damage may result.

Repairs to the foam can be made using virtually any adhesive (hot glue, regular CA [cyanoacrylate adhesive], epoxy, etc). Use of CA accelerator on the aircraft can damage paint. DO NOT handle the aircraft until accelerator fully dries. When damaged parts are not repairable, see the Replacement Parts list for ordering by item number.

Service of Power Components

WARNING: Always disconnect the flight battery from the model before removing the propeller.

Disassembly

1. Remove the wing from the aircraft.
2. Use a long 2.5mm hex driver inside the motor pod to remove the four screws (A) from the motor mount.
3. Unplug the motor wires from the ESC, and pull the motor (B) from the mount.

Assemble in reverse order.

If, after assembly, the motor spins in the wrong direction, switch the connections of any two of the ESC/motor wires.

Assembly Tips

- If, after assembly, the motor spins in the wrong direction, switch the connections of any two of the ESC/motor wires.
- The raised lettering on the propeller must face forward toward the motor for correct propeller operation.

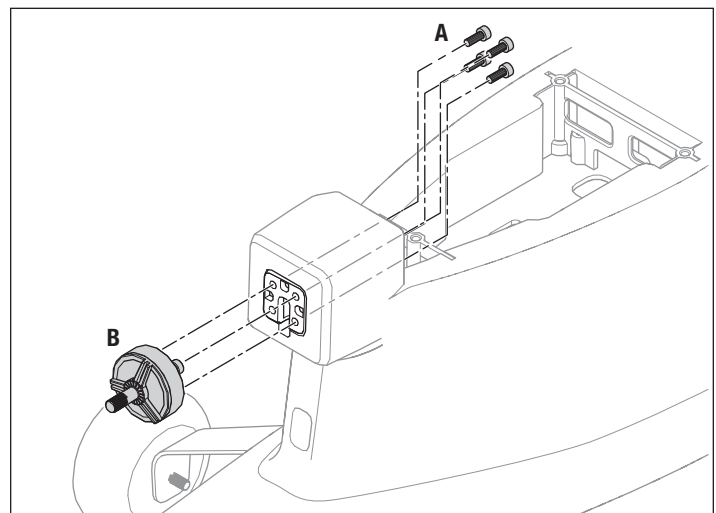

AS3X® System Trouble Shooting Guide

Problem	Possible Cause	Solution
Trim change when flight mode is switched	Trim is not at neutral	If you need to adjust the trim more than 8 clicks, return the trim to neutral and manually adjust the clevis to center the trim
	Sub-Trim is not at neutral	Do not use Sub-Trim. Adjust the servo arm or the clevis

Trouble Shooting Guide

Problem	Possible Cause	Solution
Aircraft does not operate	There is no link between the transmitter and receiver	Re-Bind the system following directions in this manual
	Transmitter AA batteries are depleted or installed incorrectly as indicated by a dim or unlit LED on the transmitter or the low battery alarm	Check polarity installation or replace with fresh AA batteries
	No electrical connection	Push connectors together until they are secure
	Flight battery is not charged	Fully charge the battery
	Crash has damaged the radio inside the fuselage	Replace the fuselage or receiver
Aircraft keeps turning in one direction	Rudder or rudder trim is not adjusted correctly	Adjust stick trims, then land and manually adjust aileron and/or rudder linkages so no transmitter trim is required
	Aileron or aileron trim is not adjusted correctly	Adjust stick trims or manually adjust aileron positions
Aircraft is difficult to control	Wing or tail is damaged	Replace damaged part
	Damaged propeller	Land immediately and replace damaged propeller
	Center of gravity is behind the recommended location	Shift battery forward, do not fly until correct Center of Gravity location is achieved
Aircraft nose rises steeply at half throttle	Wind is too gusty or strong	Postpone flying until the wind calms down
	Elevator is trimmed 'up' too much	If trim must be adjusted more than 4 clicks when pushing the trim button, adjust push rod length
	Battery is not installed in the correct position.	Move forward approximately 1/2"
Aircraft will not climb	Battery is not fully charged	Fully charge battery before flying
	Elevator may be trimmed 'down'	Adjust elevator trim 'up'
	Propeller damaged or installed incorrectly	Land immediately, replace or install propeller correctly
Aircraft is difficult to launch in the wind	Launching the aircraft down wind or into a cross wind	Always launch the aircraft directly into the wind
Flight time is too short	Battery is not fully charged	Recharge battery
	Flying at full throttle for the entire flight	Fly at just above half throttle to increase flying time
	Wind speed too fast for safe flight	Fly on a calmer day
	Propeller damaged	Replace propeller
Aircraft vibrates	Propeller, spinner or motor damaged	Tighten or replace parts
Rudder, ailerons or elevator do not move freely	Damaged or blocked push rods or hinges	Repair damage or blockage
Aircraft will not Bind (during binding) to transmitter	Transmitter is too near aircraft during binding process	Move powered transmitter a few feet from aircraft, disconnect and reconnect battery to aircraft
	Aircraft or transmitter is too near a large metal object, wireless source or another transmitter	Move the aircraft and transmitter to another location and attempt binding again
	Bind plug is not installed correctly	Install bind plug and bind aircraft to transmitter
	Flight battery/transmitter battery charge is too low	Replace/recharge batteries
Aircraft will not connect (after binding) to transmitter	Transmitter is too near aircraft during connecting process	Move powered transmitter a few feet from aircraft, disconnect and reconnect battery to aircraft
	Aircraft or transmitter is too near a large metal object, wireless source or another transmitter	Move the aircraft and transmitter to another location and attempt connecting again
	Bind plug is left installed	Rebind transmitter to aircraft and remove bind plug before cycling power
	Aircraft battery/Transmitter battery charge is too low	Replace/recharge batteries
	Transmitter may have been bound to a different model (using different DSM Protocol)	Bind aircraft to transmitter
After being properly adjusted, aileron and/or rudder are not in neutral position when battery is plugged in	Model was moved during initial power on	Unplug flight battery and reconnect, keeping model immobile for at least 5 seconds

Replacement Parts List

Part #	Description
HBZ3801	Fuselage w/Servos
HBZ3802	Hatch
HBZ3803	Wing Set w/Servos
HBZ3804	Horizontal Fin Set
HBZ3805	Nose Gear w/wheel
HBZ3806	Main Landing Gear Set
HBZ3807	Prop (2)
HBZ3808	30A ESC
HBZ3809	2306-2250 Motor
SPMAR636	AR636 6-Ch AS3X Sport Receiver
SPMR1000	DXe Transmitter Only
SPMSA390	8g Servo
SPMX22003S30	SMART 2200mah 3S 11.1V 30C LiPo; IC3
SPMXC1020	S120 USB-C SMART Charger, 1x20W
HBZ3810	Hardware Set

Limited Warranty

What this Warranty Covers

Horizon Hobby, LLC, (Horizon) warrants to the original purchaser that the product purchased (the "Product") will be free from defects in materials and workmanship at the date of purchase.

What is Not Covered

This warranty is not transferable and does not cover (i) cosmetic damage, (ii) damage due to acts of God, accident, misuse, abuse, negligence, commercial use, or due to improper use, installation, operation or maintenance, (iii) modification of or to any part of the Product, (iv) attempted service by anyone other than a Horizon Hobby authorized service center, (v) Product not purchased from an authorized Horizon dealer, or (vi) Product not compliant with applicable technical regulations, or (vii) use that violates any applicable laws, rules, or regulations.

OTHER THAN THE EXPRESS WARRANTY ABOVE, HORIZON MAKES NO OTHER WARRANTY OR REPRESENTATION, AND HEREBY DISCLAIMS ANY AND ALL IMPLIED WARRANTIES, INCLUDING, WITHOUT LIMITATION, THE IMPLIED WARRANTIES OF NON-INFRINGEMENT, MERCHANTABILITY AND FITNESS FOR A PARTICULAR PURPOSE. THE PURCHASER ACKNOWLEDGES THAT THEY ALONE HAVE DETERMINED THAT THE PRODUCT WILL SUITABLY MEET THE REQUIREMENTS OF THE PURCHASER'S INTENDED USE.

Purchaser's Remedy

Horizon's sole obligation and purchaser's sole and exclusive remedy shall be that Horizon will, at its option, either (i) service, or (ii) replace, any Product determined by Horizon to be defective. Horizon reserves the right to inspect any and all Product(s) involved in a warranty claim. Service or replacement decisions are at the sole discretion of Horizon. Proof of purchase is required for all warranty claims. SERVICE OR REPLACEMENT AS PROVIDED UNDER THIS WARRANTY IS THE PURCHASER'S SOLE AND EXCLUSIVE REMEDY.

Limitation of Liability

HORIZON SHALL NOT BE LIABLE FOR SPECIAL, INDIRECT, INCIDENTAL OR CONSEQUENTIAL DAMAGES, LOSS OF PROFITS OR PRODUCTION OR COMMERCIAL LOSS IN ANY WAY, REGARDLESS OF WHETHER SUCH CLAIM IS BASED IN CONTRACT, WARRANTY, TORT, NEGLIGENCE, STRICT LIABILITY OR ANY OTHER THEORY OF LIABILITY, EVEN IF HORIZON HAS BEEN ADVISED OF THE POSSIBILITY OF SUCH DAMAGES. Further, in no event shall the liability of Horizon exceed the individual price of the Product on which liability is asserted. As Horizon has no control over use, setup, final assembly, modification or misuse, no liability shall be assumed nor accepted for any resulting damage or injury. By the act of use, setup or assembly, the user accepts all resulting liability. If you as the purchaser or user are not prepared to accept the liability associated with the use of the Product, purchaser is advised to return the Product immediately in new and unused condition to the place of purchase.

Optional Parts List

Part #	Description
DYNC2030	Prophet Sport Mini 50W Charger
EFLA111	LiPo Cell Voltage Checker
SPM6716	Spektrum DSMR Transmitter Case
SPM6722	Spektrum Single Aircraft TX Case
SPMA3051	Standard Servo Extension 6"
SPMR12000	iX12 12 Channel Transmitter Only
SPMR8100	DX8e 8CH Transmitter Only
SPMR9910	DX9 Black Transmitter Only MD2
SPMXBC100	SMART Battery & Servo Tester
SPMXC1000	SMART S1200 DC Charger, 1x200W
SPMXC10201	30A 540W Power Supply

Law

These terms are governed by Illinois law (without regard to conflict of law principals). This warranty gives you specific legal rights, and you may also have other rights which vary from state to state. Horizon reserves the right to change or modify this warranty at any time without notice.

WARRANTY SERVICES

Questions, Assistance, and Services

Your local hobby store and/or place of purchase cannot provide warranty support or service. Once assembly, setup or use of the Product has been started, you must contact your local distributor or Horizon directly. This will enable Horizon to better answer your questions and service you in the event that you may need any assistance. For questions or assistance, please visit our website at www.horizonhobby.com, submit a Product Support Inquiry, or call the toll free telephone number referenced in the Warranty and Service Contact Information section to speak with a Product Support representative.

Inspection or Services

If this Product needs to be inspected or serviced and is compliant in the country you live and use the Product in, please use the Horizon Online Service Request submission process found on our website or call Horizon to obtain a Return Merchandise Authorization (RMA) number. Pack the Product securely using a shipping carton. Please note that original boxes may be included, but are not designed to withstand the rigors of shipping without additional protection. Ship via a carrier that provides tracking and insurance for lost or damaged parcels, as Horizon is not responsible for merchandise until it arrives and is accepted at our facility. An Online Service Request is available at http://www.horizonhobby.com/content/service-center_render-service-center. If you do not have internet access, please contact Horizon Product Support to obtain a RMA number along with instructions for submitting your product for service. When calling Horizon, you will be asked to provide your complete name, street address, email address and phone number where you can be reached during business hours. When sending product into Horizon, please include your RMA number, a list of the included items, and a brief summary of the problem. A copy of your original sales receipt must be included for warranty consideration. Be sure your name, address, and RMA number are clearly written on the outside of the shipping carton.

NOTICE: Do not ship LiPo batteries to Horizon. If you have any issue with a LiPo battery, please contact the appropriate Horizon Product Support office.

Warranty Requirements

For Warranty consideration, you must include your original sales receipt verifying the proof-of-purchase date. Provided warranty conditions have been met, your Product will be serviced or replaced free of charge. Service or replacement decisions are at the sole discretion of Horizon.

Non-Warranty Service

Should your service not be covered by warranty, service will be completed and payment will be required without notification or estimate of the expense unless the expense exceeds 50% of the retail purchase cost. By submitting the item for service you are agreeing to payment of the service without notification. Service estimates are available upon request. You must include this request with your item submitted for service. Non-warranty service estimates will be billed a minimum of ½ hour of labor. In addition you will be billed for return freight. Horizon accepts money orders and cashier's checks, as well as Visa, MasterCard, American Express, and Discover cards. By submitting any item to Horizon for service, you are agreeing to Horizon's Terms and Conditions found on our website http://www.horizonhobby.com/content/service-center_render-service-center.

ATTENTION: Horizon service is limited to Product compliant in the country of use and ownership. If received, a non-compliant Product will not be serviced. Further, the sender will be responsible for arranging return shipment of the un-serviced Product, through a carrier of the sender's choice and at the sender's expense. Horizon will hold non-compliant Product for a period of 60 days from notification, after which it will be discarded.

10/15

Contact Information

Country of Purchase	Horizon Hobby	Contact Information	Address
United States of America	Horizon Service Center (Repairs and Repair Requests)	servicecenter.horizonhobby.com/ RequestForm/	2904 Research Road Champaign, Illinois, 61822 USA
	Horizon Product Support (Product Technical Assistance)	productsupport@horizonhobby.com 877-504-0233	
	Sales	websales@horizonhobby.com 800-338-4639	
European Union	Horizon Technischer Service	service@horizonhobby.eu	Hanskampring 9 D 22885 Barsbüttel, Germany
	Sales: Horizon Hobby GmbH	+49 (0) 4121 2655 100	

FCC Information**FCC ID: BRWDXE****BRWDASRX15**

This device complies with part 15 of the FCC rules. Operation is subject to the following two conditions: (1) This device may not cause harmful interference, and (2) this device must accept any interference received, including interference that may cause undesired operation.



CAUTION: Changes or modifications not expressly approved by the party responsible for compliance could void the user's authority to operate the equipment.

This product contains a radio transmitter with wireless technology which has been tested and found to be compliant with the applicable regulations governing a radio transmitter in the 2.400GHz to 2.4835GHz frequency range.

Supplier's Declaration of Conformity**HBZ AeroScout S 1.1m RTF, BNF Basic (HBZ3800, HBZ3850)****BRWDXE****BRWDASRX15**

 This device complies with part 15 of the FCC Rules. Operation is subject to the following two conditions: (1) This device may not cause harmful interference, and (2) this device must accept any interference received, including interference that may cause undesired operation.



CAUTION: Changes or modifications not expressly approved by the party responsible for compliance could void the user's authority to operate the equipment.

NOTE: This equipment has been tested and found to comply with the limits for a Class B digital device, pursuant to part 15 of the FCC Rules. These limits are designed to provide reasonable protection against harmful interference in a residential installation. This equipment generates, uses and can radiate radio frequency energy and, if not installed and used in accordance with the instructions, may cause harmful interference to radio communications. However, there is no guarantee that interference will not occur in a particular installation. If this equipment does cause harmful interference to radio or television reception, which can be determined by turning the equipment off and on, the user is encouraged to try to correct the interference by one or more of the following measures:

- Reorient or relocate the receiving antenna.
- Increase the separation between the equipment and receiver.
- Connect the equipment into an outlet on a circuit different from that to which the receiver is connected.
- Consult the dealer or an experienced radio/TV technician for help.

Horizon Hobby, LLC

2904 Research Rd.,

Champaign, IL 61822

Email: compliance@horizonhobby.com

Web: HorizonHobby.com

IC Information

IC: 6157A-DXE

6157A-AMRX15

CAN ICES-3 (B)/NMB-3(B)

This device complies with Industry Canada licence-exempt RSS standard(s). Operation is subject to the following two conditions:

(1) this device may not cause interference, (2) this device must accept any interference, including interference that may cause undesired operation of the device.

Compliance Information for the European Union



HBZ AeroScout S 1.1m RTF (HBZ3800)

EU Compliance Statement: Horizon Hobby, LLC hereby declares that this product is in compliance with the essential requirements and other relevant provisions of the RED and EMC directives.

A copy of the EU Declaration of Conformity is available online at: <http://www.horizonhobby.com/content/support-render-compliance>.

CHBZ AeroScout S 1.1m BNF Basic (HBZ3850)

EU Compliance Statement: Horizon Hobby, LLC hereby declares that this product is in compliance with the essential requirements and other relevant provisions of the RED and EMC directives.

Instructions for disposal of WEEE by users in the European Union



This product must not be disposed of with other waste. Instead, it is the user's responsibility to dispose of their waste equipment by handing it over to a designated collection point for the recycling of waste electrical and electronic equipment. The separate collection and recycling of your waste equipment at the time of

disposal will help to conserve natural resources and ensure that it is recycled in a manner that protects human health and the environment. For more information about where you can drop off your waste equipment for recycling, please contact your local city office, your household waste disposal service or where you purchased the product.



E328

AMA National Model Aircraft Safety Code

Effective January 1, 2014

A. GENERAL

A model aircraft is a non-human-carrying aircraft capable of sustained flight in the atmosphere. It may not exceed limitations of this code and is intended exclusively for sport, recreation, education and/or competition. All model flights must be conducted in accordance with this safety code and any additional rules specific to the flying site.

1. Model aircraft will not be flown:
 - (a) In a careless or reckless manner.
 - (b) At a location where model aircraft activities are prohibited.
2. Model aircraft pilots will:
 - (a) Yield the right of way to all man carrying aircraft.
 - (b) See and avoid all aircraft and a spotter must be used when appropriate. (AMA Document #540-D.)
 - (c) Not fly higher than approximately 400 feet above ground level within three (3) miles of an airport, without notifying the airport operator.
 - (d) Not interfere with operations and traffic patterns at any airport, heliport or seaplane base except where there is a mixed use agreement.
 - (e) Not exceed a takeoff weight, including fuel, of 55 pounds unless in compliance with the AMA Large Model Aircraft program. (AMA Document 520-A.)
 - (f) Ensure the aircraft is identified with the name and address or AMA number of the owner on the inside or affixed to the outside of the model aircraft. (This does not apply to model aircraft flown indoors).
 - (g) Not operate aircraft with metal-blade propellers or with gaseous boosts except for helicopters operated under the provisions of AMA Document #555.
 - (h) Not operate model aircraft while under the influence of alcohol or while using any drug which could adversely affect the pilot's ability to safely control the model.
 - (i) Not operate model aircraft carrying pyrotechnic devices which explode or burn, or any device which propels a projectile or drops any object that creates a hazard to persons or property.

Exceptions:

 - Free Flight fuses or devices that burn producing smoke and are securely attached to the model aircraft during flight.
 - Rocket motors (using solid propellant) up to a G-series size may be used provided they remain attached to the model during flight. Model rockets may be flown in accordance with the National Model Rocketry Safety Code but may not be launched from model aircraft.
 - Officially designated AMA Air Show Teams (AST) are authorized to use devices and practices as defined within the Team AMA Program Document (AMA Document #718).
 - (j) Not operate a turbine-powered aircraft, unless in compliance with the AMA turbine regulations. (AMA Document #510-A).
3. Model aircraft will not be flown in AMA sanctioned events, air shows or model demonstrations unless:
 - (a) The aircraft, control system and pilot skills have successfully demonstrated all maneuvers intended or anticipated prior to the specific event.
 - (b) An inexperienced pilot is assisted by an experienced pilot.
4. When and where required by rule, helmets must be properly worn and fastened. They must be OSHA, DOT, ANSI, SNELL or NOCSAE approved or comply with comparable standards.

B. RADIO CONTROL

1. All pilots shall avoid flying directly over unprotected people, vessels, vehicles or structures and shall avoid endangerment of life and property of others.
2. A successful radio equipment ground-range check in accordance with manufacturer's recommendations will be completed before the first flight of a new or repaired model aircraft.
3. At all flying sites a safety line(s) must be established in front of which all flying takes place (AMA Document #706.)
 - (a) Only personnel associated with flying the model aircraft are allowed at or in front of the safety line.
 - (b) At air shows or demonstrations, a straight safety line must be established.
 - (c) An area away from the safety line must be maintained for spectators.
 - (d) Intentional flying behind the safety line is prohibited.
4. RC model aircraft must use the radio-control frequencies currently allowed by the Federal Communications Commission (FCC). Only individuals properly licensed by the FCC are authorized to operate equipment on Amateur Band frequencies.
5. RC model aircraft will not operate within three (3) miles of any pre-existing flying site without a frequency-management agreement (AMA Documents #922 and #923.)
6. With the exception of events flown under official AMA Competition Regulations, excluding takeoff and landing, no powered model may be flown outdoors closer than 25 feet to any individual, except for the pilot and the pilot's helper(s) located at the flight line.
7. Under no circumstances may a pilot or other person touch a model aircraft in flight while it is still under power, except to divert it from striking an individual.
8. RC night flying requires a lighting system providing the pilot with a clear view of the model's attitude and orientation at all times. Hand-held illumination systems are inadequate for night flying operations.
9. The pilot of a RC model aircraft shall:
 - (a) Maintain control during the entire flight, maintaining visual contact without enhancement other than by corrective lenses prescribed for the pilot.
 - (b) Fly using the assistance of a camera or First-Person View (FPV) only in accordance with the procedures outlined in AMA Document #550.
 - (c) Fly using the assistance of autopilot or stabilization system only in accordance with the procedures outlined in AMA Document #560.

Please see your local or regional modeling association's guidelines for proper, safe operation of your model aircraft.



© 2019 Horizon Hobby, LLC

HobbyZone, the HobbyZone logo, E-flite, SAFE, the SAFE logo, DSM, DSM2, DSMX, IC3, Bind-N-Fly, the BNF logo, and the Horizon Hobby logo are trademarks or registered trademarks of Horizon Hobby, LLC. The Spektrum trademark is used with permission of Bachmann Industries, Inc. US 9,056,667. US 8,672,726. D774,933. US 9,930,567.

www.horizonhobby.com

Created 03/19

59990

HBZ3800, HBZ3850