

2 Technical Data and Dimension Sheets

2.1 CE-marking, UL approval and C-Tick

CE marking

- Low voltage directive
MOVIDRIVE® MDX60B/61B inverters comply with the regulations of the Low Voltage Directive 2006/95/EC.
- Electromagnetic compatibility (EMC)
The designated use of MOVIDRIVE® inverters and regenerative power supply units is as components for installation in machinery and systems. They comply with the EMC product standard EN 61800-3 "Variable-speed electrical drives." Provided the installation instructions are complied with, they satisfy the relevant requirements for the CE marking for the entire machine/system in which they are installed, on the basis of the EMC Directive 89/336/EEC. For detailed information on EMC compliant installation, refer to the publication "Electromagnetic Compatibility in Drive Engineering" from SEW-EURODRIVE.
- Compliance with limit classes C1 or C2 has been tested on a specified test setup. SEW-EURODRIVE can provide detailed information on request.



The CE-mark on the nameplate indicates conformity with the low voltage directive 2006/95/EC. We can provide a declaration of conformity on request.

UL / cUL / GOST-R

UL, cUL approval (USA) and the GOST-R certificate (Russia) have been approved for the entire MOVIDRIVE® unit series. cUL is equivalent to CSA approval.



C-Tick



C-Tick approval has been granted for the entire MOVIDRIVE® range of units. C-Tick certifies conformity with ACMA (Australian Communications and Media Authority) standards.

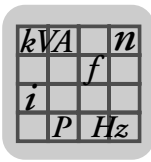

2.2 General technical data

The following table lists the technical data applicable to all MOVIDRIVE® MDX60B/61B inverters, regardless of their type, version, size and performance.

| MOVIDRIVE® MDX60B/61B | All sizes |
|---|---|
| Interference resistance | Complies with EN 61800-3 |
| Interference emission with EMC compliant installation | Sizes 0 to 6 meet EN 61800-3 Sizes 0 to 5: According to limit value class C1 to EN 61800-3 with a corresponding line filter Sizes 0, 1, and 2 in accordance with limit value class C2 to EN 61800-3 without additional measures Size 6 in accordance with limit value class C2 to EN 61800-3 with corresponding line filter |
| Ambient temperature ϑ_U I_N reduction Ambient temperature Climate class | 0 °C...+50 °C at $I_D = 100\% I_N$ and $f_{PWM} = 4$ kHz 0 °C...+40 °C at $I_D = 125\% I_N$ and $f_{PWM} = 4$ kHz 0 °C...+40 °C at $I_D = 100\% I_N$ and $f_{PWM} = 8$ kHz 2.5 % I_N per K between 40 °C - 50 °C 3 % I_N per K at 50 °C - 60 °C EN 60721-3-3, class 3K3 |
| Storage temperature¹⁾ ϑ_L | -25 °C...+70 °C (EN 60721-3-3, class 3K3) DBG keypad: -20 °C...+60 °C |
| Cooling type (DIN 41751) | Forced cooling (temperature-controlled fan, response threshold 45 °C) |
| Enclosure EN 60529 (NEMA1) Sizes 0 to 3 Sizes 4 to 6 | IP20 IP00 (power connections) IP10 (power connections) with <ul style="list-style-type: none"> • fitted plexiglass cover supplied as standard and • shrink tubing (not included in scope of delivery) |
| Duty cycle | Continuous operation with 50% overload capacity (size 0: 100 %) |
| Overvoltage category | III according to IEC 60664-1 (VDE 0110-1) |
| Pollution class | 2 according to IEC 60664-1 (VDE 0110-1) |
| Installation altitude h | Up to $h = 1000$ m (3281 ft) without restrictions. At $h \geq 1000$ m (3281 ft), the following restrictions apply: <ul style="list-style-type: none"> • from 1000 m (3281 ft) to max. 4000 m (13120 ft): <ul style="list-style-type: none"> - I_N reduction by 1% per 100 m (328 ft) • from 2,000 m (6562 ft) to max. 4000 m (13120 ft): <ul style="list-style-type: none"> - AC 230 V units: U_N reduction by AC 3 V per 100 m (328 ft) - AC 500 V units: U_N reduction by AC 6 V per 100 m (328 ft) Over 2000 m (6562 ft) only overvoltage class 2, external measures are required for overvoltage class 3. Overvoltage classes according to DIN VDE 0110-1. |

1) In case of long-term storage, the unit must be connected to the mains voltage for at least 5 minutes, otherwise the unit's service life may be reduced.

| | |
|-------|------|
| kVA | n |
| | f |
| i | |
| P | Hz |

**MOVIDRIVE®
MDX60B/61B
series, size 0**



Figure 6: MOVIDRIVE® MDX60/61B series, size 0

51485AXX

**MOVIDRIVE®
MDX61B series,
sizes 1 to 6**



Figure 7: MOVIDRIVE® MDX61B series, sizes 1 to 6

52159AXX

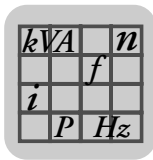
2.3 MOVIDRIVE® MDX60/61B...-5_3 (AC 400/500 V units)
Size 0

| MOVIDRIVE® MDX60/61B | 0005-5A3-4-0_ | 0008-5A3-4-0_ | 0011-5A3-4-0_ | 0014-5A3-4-0_ | |
|--|---|----------------------|----------------------|----------------------|----------------------|
| Size | OS | | OM | | |
| INPUT | | | | | |
| Rated supply voltage (to EN 50160) V_{supply} | 3 × AC 380 V -500 V | | | | |
| Supply frequency f_{supply} | 50 Hz ... 60 Hz ±5 % | | | | |
| Rated supply current ¹⁾ (at $V_{\text{supply}} = 3 \times \text{AC } 400 \text{ V}$) I_{supply} | 100% 125 % | AC 1.8 A AC 2.3 A | AC 2.2 A AC 2.7 A | AC 2.8 A AC 3.5 A | AC 3.6 A AC 4.5 A |
| OUTPUT | | | | | |
| Apparent output power ²⁾ (at $V_{\text{supply}} = 3 \times \text{AC } 380 \dots 500 \text{ V}$) S_N | 1.4 kVA | 1.6 kVA | 2.1 kVA | 2.8 kVA | |
| Rated output current ¹⁾ (at $V_{\text{supply}} = 3 \times \text{AC } 400 \text{ V}$) I_N | AC 2 A | AC 2.4 A | AC 3.1 A | AC 4 A | |
| Continuous output current (= 125 % I_N) I_D (at $V_{\text{supply}} = 3 \times \text{AC } 400 \text{ V}$ and $f_{\text{PWM}} = 4 \text{ kHz}$) | AC 2.5 A | AC 3 A | AC 3.8 A | AC 5 A | |
| Continuous output current (= 100 % I_N) I_D (at $V_{\text{supply}} = 3 \times \text{AC } 400 \text{ V}$ and $f_{\text{PWM}} = 8 \text{ kHz}$) | AC 2 A | AC 2.4 A | AC 3.1 A | AC 4 A | |
| Current limitation I_{max} | Motor and regenerative 200 % I_N , duration depending on capacity utilization | | | | |
| Internal current limitation | $I_{\text{max}} = 0..0.200 \%$ adjustable | | | | |
| Minimum permitted braking resistor value (4Q operation) R_{BRmin} | 68 Ω | | | | |
| Output voltage U_A | Max. V_{supply} | | | | |
| PWM frequency f_{PWM} | Can be set: 4/8/12/16 kHz | | | | |
| Speed range/resolution $n_A / \Delta n_A$ | -6000 ... 0 ... +6000 rpm / 0.2 rpm across the entire range | | | | |
| GENERAL INFORMATION | | | | | |
| Power loss at S_N ²⁾ P_{Vmax} | 42 W | 48 W | 58 W | 74 W | |
| Cooling air consumption | 3 m ³ /h | | 9 m ³ /h | | |
| Cross section of unit terminals X1, X2, X3, X4 | Disconnectable terminal strip 4 mm ² conductor end sleeve DIN 46228 | | | | |
| Tightening torque | 0.6 Nm | | | | |

1) The system and output currents must be reduced by 20 % from the nominal values for $V_{\text{supply}} = 3 \times \text{AC } 500 \text{ V}$.

2) The performance data applies to $f_{\text{PWM}} = 4 \text{ kHz}$.

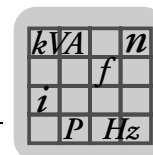

| MDX61B standard version Design with coated printed circuit boards | 0005-5A3-4-00 0005-5A3-4-00/L | 0008-5A3-4-00 0008-5A3-4-00/L | 0011-5A3-4-00 0011-5A3-4-00/L | 0014-5A3-4-00 0014-5A3-4-00/L |
|--|---|----------------------------------|--|----------------------------------|
| Part number | 827 722 2 828 947 6 | 827 723 0 828 948 4 | 827 724 9 828 949 2 | 827 725 7 828 950 6 |
| MDX61B Application version Design with coated printed circuit boards | 0005-5A3-4-0T 0005-5A3-4-0T/L | 0008-5A3-4-0T 0008-5A3-4-0T/L | 0011-5A3-4-0T 0011-5A3-4-0T/L | 0014-5A3-4-0T 0014-5A3-4-0T/L |
| Part number | 827 726 5 828 951 4 | 827 727 3 828 952 2 | 827 728 1 828 953 0 | 827 729 X 828 954 9 |
| Constant load Recommended motor power P_{Mot} | 0.55 kW (0.74 HP) | 0.75 kW (1.0 HP) | 1.1 kW (1.5 HP) | 1.5 kW (2.0 HP) |
| Variable torque load or constant load without overload Recommended motor power P_{Mot} | 0.75 kW (1.0 HP) | 1.1 kW (1.5 HP) | 1.5 kW (2.0 HP) | 2.2 kW (3.0 HP) |
| Weight | 2.0 kg (4.4 lb) | | 2.5 kg (5.5 lb) | |
| Dimensions $W \times H \times D$ | 45 mm × 317 mm × 260 mm (1.8 in × 12.5 in × 10.2 in) | | 67.5 mm × 317 mm × 260 mm (2.66 in × 12.5 in × 10.2 in) | |

| MDX61B standard version (VFC/CFC/SERVO) Design with coated printed circuit boards | 0005-5A3-4-00 0005-5A3-4-00/L | 0008-5A3-4-00 0008-5A3-4-00/L | 0011-5A3-4-00 0011-5A3-4-00/L | 0014-5A3-4-00 0014-5A3-4-00/L |
|---|--|----------------------------------|---|----------------------------------|
| Part number | 827 730 3 828 955 7 | 827 731 1 828 956 5 | 827 732 X 828 957 3 | 827 733 8 828 958 1 |
| MDX61B Application version (VFC/CFC/SERVO) Design with coated printed circuit boards | 0005-5A3-4-0T 0005-5A3-4-0T/L | 0008-5A3-4-0T 0008-5A3-4-0T/L | 0011-5A3-4-0T 0011-5A3-4-0T/L | 0014-5A3-4-0T 0014-5A3-4-0T/L |
| Part number | 827 734 6 828 960 3 | 827 735 4 828 961 1 | 827 736 2 828 963 8 | 827 737 0 828 964 6 |
| Weight | 2.3 kg (5.1 lb) | | 2.8 kg (6.2 lb) | |
| Dimensions $W \times H \times D$ | 72.5 mm × 317 mm × 260 mm (2.85 in × 12.5 in × 10.2 in) | | 95 mm × 317 mm × 260 mm (3.7 in × 12.5 in × 10.2 in) | |
| Recommended motor power | → section "Motor selection" | | | |

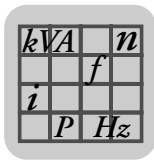





Size 1 (AC 400/500 V units)

| MOVIDRIVE® MDX61B | 0015-5A3-4-0_ | 0022-5A3-4-0_ | 0030-5A3-4-0_ | 0040-5A3-4-0_ | |
|--|---|----------------------|----------------------|----------------------|-----------------------|
| INPUT | | | | | |
| Rated supply voltage (to EN 50160) V_{supply} | 3 × AC 380 V - 500 V | | | | |
| Supply frequency f_{supply} | 50 Hz ... 60 Hz ±5 % | | | | |
| Rated supply current ¹⁾ I_{supply} (at $V_{\text{supply}} = 3 \times \text{AC } 400 \text{ V}$) | 100% 125 % | AC 3.6 A AC 4.5 A | AC 5.0 A AC 6.2 A | AC 6.3 A AC 7.9 A | AC 8.6 A AC 10.7 A |
| OUTPUT | | | | | |
| Apparent output power ²⁾ S_N (at $V_{\text{supply}} = 3 \times \text{AC } 380 \dots 500 \text{ V}$) | 2.8 kVA | 3.8 kVA | 4.9 kVA | 6.6 kVA | |
| Rated output current ¹⁾ I_N (at $V_{\text{supply}} = 3 \times \text{AC } 400 \text{ V}$) | AC 4 A | AC 5.5 A | AC 7 A | AC 9.5 A | |
| Continuous output current (= 125 % I_N) I_D (at $V_{\text{supply}} = 3 \times \text{AC } 400 \text{ V}$ and $f_{\text{PWM}} = 4 \text{ kHz}$) | AC 5 A | AC 6.9 A | AC 8.8 A | AC 11.9 A | |
| Continuous output current (= 100 % I_N) I_D (at $V_{\text{supply}} = 3 \times \text{AC } 400 \text{ V}$ and $f_{\text{PWM}} = 8 \text{ kHz}$) | AC 4 A | AC 5.5 A | AC 7 A | AC 9.5 A | |
| Current limitation I_{max} | Motor and regenerative 150 % I_N , duration depending on capacity utilization | | | | |
| Internal current limitation | $I_{\text{max}} = 0 \dots 150 \%$ adjustable | | | | |
| Minimum permitted braking resistor value (4Q operation) R_{BRmin} | 68 Ω | | | | |
| Output voltage U_A | Max. V_{supply} | | | | |
| PWM frequency f_{PWM} | Can be set: 4/8/12/16 kHz | | | | |
| Speed range/resolution $n_A / \Delta n_A$ | -6000 ... 0 ... +6000 rpm / 0.2 rpm across the entire range | | | | |
| GENERAL INFORMATION | | | | | |
| Power loss at S_N ²⁾ $P_{V\text{max}}$ | 85 W | 105 W | 130 W | 180 W | |
| Cooling air consumption | 40 m ³ /h | | | | |
| Weight | 3.5 kg (7.7 lb) | | | | |
| Dimensions $W \times H \times D$ | 105 mm × 314 mm × 234 mm (4.13 in × 12.4 in × 9.21 in) | | | | |
| Cross section of unit terminals X1, X2, X3, X4 | Disconnectable terminal strip 4 mm ² conductor end sleeve DIN 46228 | | | | |
| Tightening torque | 0.6 Nm | | | | |

1) The system and output currents must be reduced by 20 % from the nominal values for $V_{\text{supply}} = 3 \times \text{AC } 500 \text{ V}$.

2) The performance data applies to $f_{\text{PWM}} = 4 \text{ kHz}$.

| MDX61B Standard version Design with coated printed circuit boards | 0015-5A3-4-00 0015-5A3-4-00/L | 0022-5A3-4-00 0022-5A3-4-00/L | 0030-5A3-4-00 0030-5A3-4-00/L | 0040-5A3-4-00 0040-5A3-4-00/L |
|--|----------------------------------|----------------------------------|----------------------------------|----------------------------------|
| Part number | 827 957 8 1840 013 2 | 827 958 6 1840 014 0 | 827 959 4 1840 015 9 | 827 960 8 1840 016 7 |
| MDX61B Application version Design with coated printed circuit boards | 0015-5A3-4-0T 0015-5A3-4-0T/L | 0022-5A3-4-0T 0022-5A3-4-0T/L | 0030-5A3-4-0T 0030-5A3-4-0T/L | 0040-5A3-4-0T 0040-5A3-4-0T/L |
| Part number | 827 975 6 1840 031 0 | 827 976 4 1840 032 9 | 827 977 2 1840 033 7 | 827 978 0 1840 034 5 |
|  Constant load  Recommended motor power P_{Mot} | 1.5 kW (2.0 HP) | 2.2 kW (3.0 HP) | 3.0 kW (4.0 HP) | 4.0 kW (5.4 HP) |
|  Variable torque load or constant load without overload  Recommended motor power P_{Mot} | 2.2 kW (3.0 HP) | 3.0 kW (4.0 HP) | 4.0 kW (5.4 HP) | 5.5 kW (7.4 HP) |
| Recommended motor power | → section "Motor selection" | | | |

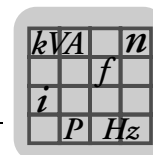



Sizes 2S, 2 (AC 400/500 V units)

| MOVIDRIVE® MDX61B | 0055-5A3-4-0_ | 0075-5A3-4-0_ | 0110-5A3-4-0_ |
|---|---|------------------------|--|
| Size | 2S | | 2 |
| INPUT | | | |
| Rated supply voltage (to EN 50160) V_{supply} | 3 × AC 380 V - 500 V | | |
| Supply frequency f_{supply} | 50 Hz ... 60 Hz ± 5 % | | |
| Rated supply current ¹⁾ (at $V_{supply} = 3 \times AC 400 V$) I_{supply} | 100% AC 11.3 A 125% AC 14.1 A | AC 14.4 A AC 18.0 A | AC 21.6 A AC 27.0 A |
| OUTPUT | | | |
| Apparent output power ²⁾ (at $V_{supply} = 3 \times AC 380...500 V$) S_N | 8.7 kVA | 11.2 kVA | 16.8 kVA |
| Rated output current ¹⁾ (at $V_{supply} = 3 \times AC 400 V$) I_N | AC 12.5 A | AC 16 A | AC 24 A |
| Continuous output current (= 125 % I_N) I_D (at $V_{supply} = 3 \times AC 400 V$ with $f_{PWM} = 4 kHz$) | AC 15.6 A | AC 20 A | AC 30 A |
| Continuous output current (= 100 % I_N) I_D (at $V_{supply} = 3 \times AC 400 V$ with $f_{PWM} = 8 kHz$) | AC 12.5 A | AC 16 A | AC 24 A |
| Current limitation I_{max} | Motor and regenerative 150 % I_N , duration depending on capacity utilization | | |
| Internal current limitation | $I_{max} = 0...150$ % adjustable | | |
| Minimum permitted braking resistor value (4Q operation) R_{BRmin} | 47 Ω | | 22 Ω |
| Output voltage U_A | Max. V_{supply} | | |
| PWM frequency f_{PWM} | Can be set: 4/8/12/16 kHz | | |
| Speed range/resolution $n_A / \Delta n_A$ | -6000 ... 0 ... +6000 rpm / 0.2 rpm across the entire range | | |
| GENERAL INFORMATION | | | |
| Power loss at S_N ²⁾ P_{Vmax} | 220 W | 290 W | 400 W |
| Cooling air consumption | 80 m ³ /h | | |
| Weight | 6.6 kg (15 lb) | | |
| Dimensions $W \times H \times D$ | 105 mm × 335 mm × 294 mm (4.13 in × 13.2 in × 11.6 in) | | 135 mm × 315 mm × 285 mm (5.31 in × 12.4 in × 11.2 in) |
| Cross section of unit terminals X1, X2, X3, X4 | Terminal blocks 4 mm ² conductor end sleeves DIN 46228 | | M4 screw and washer assembly with terminal clip 4 mm ² conductor end sleeve DIN 46228 6 mm ² crimp cable lug DIN 46234 |
| Tightening torque | 1.5 Nm | | |

1) The system and output currents must be reduced by 20 % from the nominal values for $V_{supply} = 3 \times AC 500 V$.

2) The performance data applies to $f_{PWM} = 4 kHz$.

| MDX61B Standard version Design with coated printed circuit boards | 0055-5A3-4-00 0055-5A3-4-00/L | 0075-5A3-4-00 0075-5A3-4-00/L | 0110-5A3-4-00 0110-5A3-4-00/L |
|---|----------------------------------|----------------------------------|----------------------------------|
| Part number | 827 961 6 1840 017 5 | 827 962 4 1840 018 3 | 827 963 2 1840 019 1 |
| MDX61B Application version Design with coated printed circuit boards | 0055-5A3-4-0T | 0075-5A3-4-0T | 0110-5A3-4-0T |
| Part number | 827 979 9 1840 035 3 | 827 980 2 1840 036 1 | 827 981 0 1840 038 8 |
|  Constant load Recommended motor power P_{Mot} | 5.5 kW (7.4 HP) | 7.5 kW (10 HP) | 11 kW (15 HP) |
|  Variable torque load or constant load without overload Recommended motor power P_{Mot} | 7.5 kW (10 HP) | 11 kW (15 HP) | 15 kW (20 HP) |
| Recommended motor power | → section "Motor selection" | | |

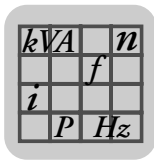



Size 3 (AC 400/500 V units)

| MOVIDRIVE® MDX61B | 0150-503-4-0_ | 0220-503-4-0_ | 0300-503-4-0_ |
|---|---|------------------------|----------------------|
| INPUT | | | |
| Rated supply voltage (to EN 50160) V_{supply} | 3 × AC 380 V - 500 V | | |
| Supply frequency f_{supply} | 50 Hz ... 60 Hz ±5 % | | |
| Rated supply current ¹⁾ (at $V_{\text{supply}} = 3 \times \text{AC } 400 \text{ V}$) I_{supply} | 100% AC 28.8 A 125 % AC 36 A | AC 41.4 A AC 51.7 A | AC 54 A AC 67.5 A |
| OUTPUT | | | |
| Apparent output power ²⁾ (at $V_{\text{supply}} = 3 \times \text{AC } 380 \dots 500 \text{ V}$) S_N | 22.2 kVA | 31.9 kVA | 41.6 kVA |
| Rated output current ¹⁾ (at $V_{\text{supply}} = 3 \times \text{AC } 400 \text{ V}$) I_N | AC 32 A | AC 46 A | AC 60 A |
| Continuous output current (= 125 % I_N) I_D (at $V_{\text{supply}} = 3 \times \text{AC } 400 \text{ V}$ with $f_{\text{PWM}} = 4 \text{ kHz}$) | AC 40 A | AC 57.5 A | AC 75 A |
| Continuous output current (= 100 % I_N) I_D (at $V_{\text{supply}} = 3 \times \text{AC } 400 \text{ V}$ with $f_{\text{PWM}} = 8 \text{ kHz}$) | AC 32 A | AC 46 A | AC 60 A |
| Current limitation I_{max} | Motor and regenerative 150 % I_N , duration depending on capacity utilization | | |
| Internal current limitation | $I_{\text{max}} = 0 \dots 150 \%$ adjustable | | |
| Minimum permitted braking resistor value (4Q operation) R_{BRmin} | 15 Ω | | 12 Ω |
| Output voltage U_A | Max. V_{supply} | | |
| PWM frequency f_{PWM} | Can be set: 4/8/12/16 kHz | | |
| Speed range/resolution $n_A / \Delta n_A$ | -6000 ... 0 ... +6000 rpm / 0.2 rpm across the entire range | | |
| GENERAL INFORMATION | | | |
| Power loss at S_N ²⁾ $P_{V\text{max}}$ | 550 W | 750 W | 950 W |
| Cooling air consumption | 180 m ³ /h | | |
| Weight | 15.0 kg (33 lb) | | |
| Dimensions $W \times H \times D$ | 200 mm × 465 mm × 308 mm (7.87 in × 18.3 in × 12.1 in) | | |
| Cross section of unit terminals X1, X2, X3, X4 | M6 screw with washer max. 25 mm ² Crimp cable lug DIN 46234 | | |
| Tightening torque | 3.5 Nm | | |

1) The system and output currents must be reduced by 20 % from the nominal values for $V_{\text{supply}} = 3 \times \text{AC } 500 \text{ V}$.

2) The performance data applies to $f_{\text{PWM}} = 4 \text{ kHz}$.

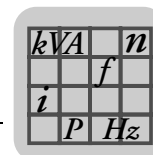

| | | | |
|--|--|--|--|
| MDX61B Standard version Design with coated printed circuit boards | 0150-503-4-00 0150-503-4-00/L | 0220-503-4-00 0220-503-4-00/L | 0300-503-4-00 0300-503-4-00/L |
| Part number | 827 964 0 1840 020 5 | 827 965 9 1840 021 3 | 827 966 7 1840 022 1 |
| MDX61B Application version Design with coated printed circuit boards | 0150-503-4-0T 0150-503-4-0T/L | 0220-503-4-0T 0220-503-4-0T/L | 0300-503-4-0T 0300-503-4-0T/L |
| Part number | 827 982 9 1840 039 6 | 827 983 7 1840 041 8 | 827 984 5 1840 042 6 |
|  Constant load Recommended motor power P_{Mot} | 15 kW (20 HP) | 22 kW (30 HP) | 30 kW (40 HP) |
|  Variable torque load or constant load without overload Recommended motor power P_{Mot} | 22 kW (30 HP) | 30 kW (40 HP) | 37 kW (50 HP) |
| Recommended motor power | → section "Motor selection" | | |



Size 4 (AC 400/500 V units)

| MOVIDRIVE® MDX61B | 0370-503-4-0_ | 0450-503-4-0_ |
|---|---|-------------------------|
| INPUT | | |
| Rated supply voltage (to EN 50160) V_{supply} | 3 × AC 380 V - 500 V | |
| Supply frequency f_{supply} | 50 Hz ... 60 Hz ±5 % | |
| Rated supply current ¹⁾ (at $V_{supply} = 3 \times AC 400 V$) I_{supply} | 100% AC 65.7 A 125 % AC 81.9 A | AC 80.1 A AC 100.1 A |
| OUTPUT | | |
| Apparent output power ²⁾ (at $V_{supply} = 3 \times AC 380...500 V$) S_N | 51.1 kVA | 62.3 kVA |
| Rated output current ¹⁾ (at $V_{supply} = 3 \times AC 400 V$) I_N | AC 73 A | AC 89 A |
| Continuous output current (= 125 % I_N) I_D (at $V_{supply} = 3 \times AC 400 V$ with $f_{PWM} = 4 kHz$) | AC 91 A | AC 111 A |
| Continuous output current (= 100 % I_N) I_D (at $V_{supply} = 3 \times AC 400 V$ with $f_{PWM} = 8 kHz$) | AC 73 A | AC 89 A |
| Current limitation I_{max} | Motor and regenerative 150 % I_N , duration depending on capacity utilization | |
| Internal current limitation | $I_{max} = 0...150$ % adjustable | |
| Minimum permitted braking resistor value (4Q operation) R_{BRmin} | 6 Ω | |
| Output voltage U_A | Max. V_{supply} | |
| PWM frequency f_{PWM} | Can be set: 4/8/12/16 kHz | |
| Speed range/resolution $n_A / \Delta n_A$ | -6000 ... 0 ... +6000 rpm / 0.2 rpm across the entire range | |
| GENERAL INFORMATION | | |
| Power loss at S_N ²⁾ P_{Vmax} | 1200 W | 1450 W |
| Cooling air consumption | 180 m ³ /h | |
| Weight | 27 kg (60 lb) | |
| Dimensions $W \times H \times D$ | 280 mm × 522 mm × 307 mm (11.0 in × 20.6 in × 12.1 in) | |
| Cross section of unit terminals X1, X2, X3, X4 | M10 bolt with nut Max. 70 mm ² Press cable lug DIN 46235 | |
| Tightening torque | 14 Nm | |

- 1) The system and output currents must be reduced by 20 % from the nominal values for $V_{supply} = 3 \times AC 500 V$.
 2) The performance data applies to $f_{PWM} = 4 kHz$.

| | | |
|---|--|--|
| MDX61B Standard version Design with coated printed circuit boards | 0370-503-4-00 0370-503-4-00/L | 0450-503-4-00 0450-503-4-00/L |
| Part number | 827 967 5 1840 024 8 | 827 968 3 1840 025 6 |
| MDX61B Application version Design with coated printed circuit boards | 0370-503-4-0T 0370-503-4-0T/L | 0450-503-4-0T 0450-503-4-0T/L |
| Part number | 827 985 3 1840 043 4 | 827 986 1 1840 044 2 |
|  Constant load Recommended motor power P_{Mot} | 37 kW (50 HP) | 45 kW (60 HP) |
|  Variable torque load or constant load without overload Recommended motor power P_{Mot} | 45 kW (60 HP) | 55 kW (74 HP) |
| Recommended motor power | → section "Motor selection" | |

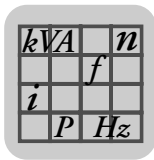



Size 5 (AC 400/500 V units)

| MOVIDRIVE® MDX61B | 0550-503-4-0_ | 0750-503-4-0_ |
|---|---|------------------------|
| INPUT | | |
| Rated supply voltage (to EN 50160) V_{supply} | 3 × AC 380 V - 500 V | |
| Supply frequency f_{supply} | 50 Hz ... 60 Hz ±5 % | |
| Rated supply current ¹⁾ (at $V_{\text{supply}} = 3 \times \text{AC } 400 \text{ V}$) I_{supply} | 100% AC 94.5 A 125 % AC 118.1 A | AC 117 A AC 146.3 A |
| OUTPUT | | |
| Apparent output power ²⁾ (at $V_{\text{supply}} = 3 \times \text{AC } 380 \dots 500 \text{ V}$) S_N | 73.5 kVA | 91.0 kVA |
| Rated output current ¹⁾ (at $V_{\text{supply}} = 3 \times \text{AC } 400 \text{ V}$) I_N | AC 105 A | AC 130 A |
| Continuous output current (= 125 % I_N) I_D (at $V_{\text{supply}} = 3 \times \text{AC } 400 \text{ V}$ with $f_{\text{PWM}} = 4 \text{ kHz}$) | AC 131 A | AC 162 A |
| Continuous output current (= 100 % I_N) I_D (at $V_{\text{supply}} = 3 \times \text{AC } 400 \text{ V}$ with $f_{\text{PWM}} = 8 \text{ kHz}$) | AC 105 A | AC 130 A |
| Current limitation I_{max} | Motor and regenerative 150 % I_N , duration depending on capacity utilization | |
| Internal current limitation | $I_{\text{max}} = 0 \dots 150 \%$ adjustable | |
| Minimum permitted braking resistor value (4Q operation) R_{BRmin} | 6 Ω | 4 Ω |
| Output voltage U_A | Max. V_{supply} | |
| PWM frequency f_{PWM} | Can be set: 4/8/12/16 kHz | |
| Speed range/resolution $n_A / \Delta n_A$ | -6000 ... 0 ... +6000 rpm / 0.2 rpm across the entire range | |
| GENERAL INFORMATION | | |
| Power loss at S_N ²⁾ $P_{V\text{max}}$ | 1700 W | 2000 W |
| Cooling air consumption | 360 m ³ /h | |
| Weight | 35 kg (77 lb) | |
| Dimensions $W \times H \times D$ | 280 mm × 610 mm × 330 mm (11.0 in × 24.0 in × 13.0 in) | |
| Cross section of unit terminals X1, X2, X3, X4 | M10 bolt with nut Max. 70 mm ² Press cable lug DIN 46235 | |
| Tightening torque | 14 Nm | |

1) The system and output currents must be reduced by 20 % from the nominal values for $V_{\text{supply}} = 3 \times \text{AC } 500 \text{ V}$.

2) The performance data applies to $f_{\text{PWM}} = 4 \text{ kHz}$.

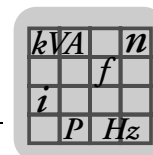

| | | |
|--|--|--|
| MDX61B Standard version Design with coated printed circuit boards | 0550-503-4-00 0550-503-4-00/L | 0750-503-4-00 0750-503-4-00/L |
| Part number | 827 969 1 1840 026 4 | 827 970 5 1840 027 2 |
| MDX61B Application version Design with coated printed circuit boards | 0550-503-4-0T 0550-503-4-0T/L | 0750-503-4-0T 0750-503-4-0T/L |
| Part number | 827 988 8 1840 045 0 | 827 989 6 1840 046 9 |
|  Constant load Recommended motor power P_{Mot} | 55 kW (74 HP) | 75 kW (100 HP) |
|  Variable torque load or constant load without overload Recommended motor power P_{Mot} | 75 kW (100 HP) | 90 kW (120 HP) |
| Recommended motor power | → section "Motor selection" | |



Size 6 (AC 400/500 V units)

| MOVIDRIVE® MDX61B | 0900-503-4-0_ | 1100-503-4-0_ | 1320-503-4-0_ |
|---|---|----------------------|----------------------|
| INPUT | | | |
| Rated supply voltage (to EN 50160) V_{supply} | 3 × AC 380 V - 500 V | | |
| Supply frequency f_{supply} | 50 Hz ... 60 Hz ±5 % | | |
| Rated supply current ¹⁾ (at $V_{supply} = 3 \times AC 400 V$) I_{supply} | 100% AC 153 A 125 % AC 191 A | AC 180 A AC 225 A | AC 225 A AC 281 A |
| OUTPUT | | | |
| Apparent output power ²⁾ (at $V_{supply} = 3 \times AC 380...500 V$) S_N | 118 kVA | 139 kVA | 174 kVA |
| Rated output current ¹⁾ (at $V_{supply} = 3 \times AC 400 V$) I_N | AC 170 A | AC 200 A | AC 250 A |
| Continuous output current (= 125 % I_N) I_D (at $V_{supply} = 3 \times AC 400 V$ with $f_{PWM} = 4 kHz$) | AC 212 A | AC 250 A | AC 312 A |
| Continuous output current (= 100 % I_N) I_D (at $V_{supply} = 3 \times AC 400 V$ with $f_{PWM} = 4 kHz$) | AC 170 A | AC 200 A | AC 250 A |
| Current limitation I_{max} | Motor and regenerative 150 % I_N , duration depending on capacity utilization | | |
| Internal current limitation | $I_{max} = 0...150$ % adjustable | | |
| Minimum permitted braking resistor value (4Q operation) R_{BRmin} | 2.7 Ω | | |
| Output voltage U_A | Max. V_{supply} | | |
| PWM frequency f_{PWM} | Can be set: 4 or 8 kHz | | |
| Speed range/resolution $n_A / \Delta n_A$ | -6000 ... 0 ... +6000 rpm / 0.2 rpm across the entire range | | |
| GENERAL INFORMATION | | | |
| Power loss at S_N ²⁾ P_{Vmax} | 2300 W | 2500 W | 2700 W |
| Cooling air consumption | 600 m ³ /h | | |
| Weight | 60 kg (130 lb) | | |
| Dimensions $W \times H \times D$ | 280 mm × 1000 mm × 382 mm (11.0 in × 39.37 in × 15.0 in) | | |
| Cross section of unit terminals X1, X2, X3, X4 | M12 bolt with nut Max. 185 mm ² Press cable lug DIN 46235 | | |
| Tightening torque | 20 Nm | | |

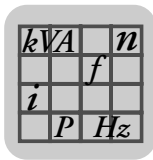

- 1) The system and output currents must be reduced by 20 % from the nominal values for $V_{supply} = 3 \times AC 500 V$.
- 2) The performance data applies to $f_{PWM} = 4 kHz$.

| MDX61B Standard version Design with coated printed circuit boards | 0900-503-4-00 0900-503-4-00/L | 1100-503-4-00 1100-503-4-00/L | 1320-503-4-00 1320-503-4-00/L |
|---|----------------------------------|----------------------------------|----------------------------------|
| Part number | 827 971 3 1840 028 0 | 827 972 1 1840 029 9 | 827 974 8 1840 030 2 |
| MDX61B Application version Design with coated printed circuit boards | 0900-503-4-0T 0900-503-4-0T/L | 1100-503-4-0T 1100-503-4-0T/L | 1320-503-4-0T 1320-503-4-0T/L |
| Part number | 827 991 8 1840 047 7 | 827 992 6 1840 048 5 | 827 993 4 1840 049 3 |
|  Constant load Recommended motor power P_{Mot} | 90 kW (120 HP) | 110 kW (148 HP) | 132 kW (177 HP) |
|  Variable torque load or constant load without overload Recommended motor power P_{Mot} | 110 kW (148 HP) | 132 kW (177 HP) | 160 kW (215 HP) |
| Recommended motor power | → section "Motor selection" | | |

2.4 MOVIDRIVE® MDX61B...-2_3 (AC 230 V units)
Size 1 (AC 230 V units)

| MOVIDRIVE® MDX61B | 0015-2A3-4-0_ | 0022-2A3-4-0_ | 0037-2A3-4-0_ |
|---|---|----------------------|------------------------|
| INPUT | | | |
| Rated supply voltage (to EN 50160) V_{supply} | 3 × AC 200 V - 240 V | | |
| Supply frequency f_{supply} | 50 Hz ... 60 Hz ± 5 % | | |
| Rated supply current I_{supply} 100 % (at $V_{\text{supply}} = 3 \times \text{AC } 230 \text{ V}$) 125 % | AC 6.7 A AC 8.4 A | AC 7.8 A AC 9.8 A | AC 12.9 A AC 16.1 A |
| OUTPUT | | | |
| Apparent output power ¹⁾ (at $V_{\text{supply}} = 3 \times \text{AC } 230..0.240 \text{ V}$) S_N | 2.7 kVA | 3.4 kVA | 5.8 kVA |
| Rated output current (at $V_{\text{supply}} = 3 \times \text{AC } 230 \text{ V}$) I_N | AC 7.3 A | AC 8.6 A | AC 14.5 A |
| Continuous output current (= 125 % I_N) I_D (at $V_{\text{supply}} = 3 \times \text{AC } 230 \text{ V}$ with $f_{\text{PWM}} = 4 \text{ kHz}$) | AC 9.1 A | AC 10.8 A | AC 18.1 A |
| Continuous output current (= 100 % I_N) I_D (at $V_{\text{supply}} = 3 \times \text{AC } 230 \text{ V}$ with $f_{\text{PWM}} = 8 \text{ kHz}$) | AC 7.3 A | AC 8.6 A | AC 14.5 A |
| Current limitation I_{max} | Motor and regenerative 150 % I_N , duration depending on capacity utilization | | |
| Internal current limitation | $I_{\text{max}} = 0...150 \%$ adjustable | | |
| Minimum permitted braking resistor value (4Q operation) R_{BRmin} | 27 Ω | | |
| Output voltage U_A | Max. V_{supply} | | |
| PWM frequency f_{PWM} | Can be set: 4/8/12/16 kHz | | |
| Speed range/resolution $n_A / \Delta n_A$ | -6000 ... 0 ... +6000 rpm / 0.2 rpm across the entire range | | |
| GENERAL INFORMATION | | | |
| Power loss at S_N ¹⁾ P_{Vmax} | 110 W | 126 W | 210 W |
| Cooling air consumption | 40 m ³ /h | | |
| Weight | 2.8 kg (6.2 lb) | | |
| Dimensions $W \times H \times D$ | 105 mm × 314 mm × 234 mm (4.13 in × 12.4 in × 9.21 in) | | |
| Cross section of unit terminals X1, X2, X3, X4 | Separable terminal block 4 mm ² conductor end sleeve DIN 46228 | | |
| Tightening torque | 0.6 Nm | | |

1) The performance data applies to $f_{\text{PWM}} = 4 \text{ kHz}$.

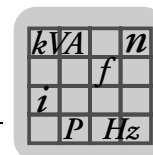

| MDX61B Standard version | 0015-2A3-4-00 | 0022-2A3-4-00 | 0037-2A3-4-00 |
|--|-----------------------------|-----------------|-----------------|
| Part number | 827 994 2 | 827 995 0 | 827 996 9 |
| MDX61B Application version | 0015-2A3-4-0T | 0022-2A3-4-0T | 0037-2A3-4-0T |
| Part number | 828 003 7 | 828 004 5 | 828 005 3 |
|  Constant load Recommended motor power P_{Mot} | 1.5 kW (2.0 HP) | 2.2 kW (3.0 HP) | 3.7 kW (5.0 HP) |
|  Variable torque load or constant load without overload Recommended motor power P_{Mot} | 2.2 kW (3.0 HP) | 3.7 kW (5.0 HP) | 5.0 kW (6.7 HP) |
| Recommended motor power | → section "Motor selection" | | |



Size 2 (AC 230 V units)

| MOVIDRIVE® MDX61B | 0055-2A3-4-0_ | 0075-2A3-4-0_ |
|---|--|------------------------|
| INPUT | | |
| Rated supply voltage (to EN 50160) V_{supply} | 3 × AC 200 V - 240 V | |
| Supply frequency f_{supply} | 50 Hz ... 60 Hz ± 5 % | |
| Rated supply current I_{supply} (at $V_{\text{supply}} = 3 \times \text{AC } 230 \text{ V}$) | 100 % AC 19.5 A 125 % AC 24.4 A | AC 27.4 A AC 34.3 A |
| OUTPUT | | |
| Apparent output power ¹⁾ (at $V_{\text{supply}} = 3 \times \text{AC } 230..0.240 \text{ V}$) | S_N 8.8 kVA | 11.6 kVA |
| Rated output current (at $V_{\text{supply}} = 3 \times \text{AC } 230 \text{ V}$) | I_N AC 22 A | AC 29 A |
| Continuous output current (= 125 % I_N) I_D (at $V_{\text{supply}} = 3 \times \text{AC } 230 \text{ V}$ with $f_{\text{PWM}} = 4 \text{ kHz}$) | AC 27.5 A | AC 36.3 A |
| Continuous output current (= 100 % I_N) I_D (at $V_{\text{supply}} = 3 \times \text{AC } 230 \text{ V}$ with $f_{\text{PWM}} = 8 \text{ kHz}$) | AC 22 A | AC 29 A |
| Current limitation I_{max} | Motor and regenerative 150 % I_N , duration depending on capacity utilization | |
| Internal current limitation | $I_{\text{max}} = 0...150 \%$ adjustable | |
| Minimum permitted braking resistor value (4Q operation) R_{BRmin} | 12 Ω | |
| Output voltage U_A | Max. V_{supply} | |
| PWM frequency f_{PWM} | Can be set: 4/8/12/16 kHz | |
| Speed range/resolution $n_A / \Delta n_A$ | -6000 ... 0 ... +6000 rpm / 0.2 rpm across the entire range | |
| GENERAL INFORMATION | | |
| Power loss at S_N ¹⁾ $P_{V\text{max}}$ | 300 W | 380 W |
| Cooling air consumption | 80 m ³ /h | |
| Weight | 5.9 kg (13 lb) | |
| Dimensions $W \times H \times D$ | 135 mm × 315 mm × 285 mm (5.31 in × 12.4 in × 11.2 in) | |
| Cross section of unit terminals X1, X2, X3, X4 | M4 screw and washer assembly with terminal clip 4 mm ² conductor end sleeve DIN 46228 6 mm ² crimp cable lug DIN 46234 | |
| Tightening torque | 0.6 Nm | |

1) The performance data applies to $f_{\text{PWM}} = 4 \text{ kHz}$.

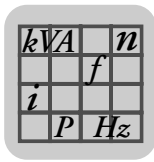

| | | |
|--|-----------------------------|----------------------|
| MDX61B Standard version | 0055-2A3-4-00 | 0075-2A3-4-00 |
| Part number | 827 997 7 | 827 998 5 |
| MDX61B Application version | 0055-2A3-4-0T | 0075-2A3-4-0T |
| Part number | 828 006 1 | 828 008 8 |
|  Constant load Recommended motor power P_{Mot} | 5.5 kW (7.4 HP) | 7.5 kW (10 HP) |
|  Variable torque load or constant load without overload Recommended motor power P_{Mot} | 7.5 kW (10 HP) | 11 kW (15 HP) |
| Recommended motor power | → section "Motor selection" | |



Size 3 (AC 230 V units)

| MOVIDRIVE® MDX61B | 0110-203-4-0_ | 0150-203-4-0_ |
|--|--|--------------------|
| INPUT | | |
| Rated supply voltage (to EN 50160) V_{supply} | 3 × AC 200 V - 240 V | |
| Supply frequency f_{supply} | 50 Hz ... 60 Hz ± 5 % | |
| Rated supply current (at $V_{\text{supply}} = 3 \times \text{AC } 230 \text{ V}$) I_{supply} | 100 % AC 40 A 125 % AC 50 A | AC 49 A AC 61 A |
| OUTPUT | | |
| Apparent output power ¹⁾ (at $V_{\text{supply}} = 3 \times \text{AC } 230..0.240 \text{ V}$) S_N | 17.1 kVA | 21.5 kVA |
| Rated output current (at $V_{\text{supply}} = 3 \times \text{AC } 230 \text{ V}$) I_N | AC 42 A | AC 54 A |
| Continuous output current (= 125 % I_N) I_D (at $V_{\text{supply}} = 3 \times \text{AC } 230 \text{ V}$ with $f_{\text{PWM}} = 4 \text{ kHz}$) | AC 52.5 A | AC 67.5 A |
| Continuous output current (= 100 % I_N) I_D (at $V_{\text{supply}} = 3 \times \text{AC } 230 \text{ V}$ with $f_{\text{PWM}} = 8 \text{ kHz}$) | AC 42 A | AC 54 A |
| Current limitation I_{max} | Motor and regenerative 150 % I_N , duration depending on capacity utilization | |
| Internal current limitation | $I_{\text{max}} = 0...150 \%$ adjustable | |
| Minimum permitted braking resistor value (4Q operation) R_{BRmin} | 7.5 Ω | 5.6 Ω |
| Output voltage U_A | Max. V_{supply} | |
| PWM frequency f_{PWM} | Can be set: 4/8/12/16 kHz | |
| Speed range/resolution $n_A / \Delta n_A$ | -6000 ... 0 ... +6000 rpm / 0.2 rpm across the entire range | |
| GENERAL INFORMATION | | |
| Power loss at S_N ¹⁾ P_{Vmax} | 580 W | 720 W |
| Cooling air consumption | 180 m ³ /h | |
| Weight | 14.3 kg (31.5 lb) | |
| Dimensions $W \times H \times D$ | 200 mm × 465 mm × 308 mm (7.87 in × 18.3 in × 12.1 in) | |
| Cross section of unit terminals X1, X2, X3, X4 | M6 screw and washer assembly with washer max. 25 mm ² Crimp cable lug DIN 46234 | |
| Tightening torque | 3.5 Nm | |

1) The performance data applies to $f_{\text{PWM}} = 4 \text{ kHz}$.

| MDX61B Standard version | 0110-203-4-00 | 0150-203-4-00 |
|--|-----------------------------|---------------|
| Part number | 827 999 3 | 828 000 2 |
| MDX61B Application version | 0110-203-4-0T | 0150-203-4-0T |
| Part number | 828 009 6 | 828 011 8 |
|  Constant load Recommended motor power P_{Mot} | 11 kW (15 HP) | 15 kW (20 HP) |
|  Variable torque load or constant load without overload Recommended motor power P_{Mot} | 15 kW (20 HP) | 22 kW (30 HP) |
| Recommended motor power | → section "Motor selection" | |

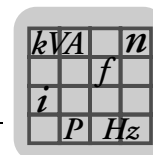

Size 4 (AC 230 V units)

| MOVIDRIVE® MDX61B | 0220-203-4-0_ | 0300-203-4-0_ |
|--|---|---------------------|
| INPUT | | |
| Rated supply voltage (to EN 50160) V_{supply} | 3 × AC 200 V - 240 V | |
| Supply frequency f_{supply} | 50 Hz ... 60 Hz ± 5 % | |
| Rated supply current I_{supply} (at $V_{supply} = 3 \times AC\ 230\ V$) | 100 % AC 72 A 125 % AC 90 A | AC 86 A AC 107 A |
| OUTPUT | | |
| Apparent output power ¹⁾ (at $U_{supply} = 3 \times AC\ 230...240\ V$) | S_N 31.8 kVA | 37.8 kVA |
| Rated output current (at $V_{supply} = 3 \times AC\ 230\ V$) | I_N AC 80 A | AC 95 A |
| Continuous output current (= 125 % I_N) I_D (at $V_{supply} = 3 \times AC\ 230\ V$ with $f_{PWM} = 4\ kHz$) | AC 100 A | AC 118 A |
| Continuous output current (= 100 % I_N) I_D (at $V_{supply} = 3 \times AC\ 230\ V$ with $f_{PWM} = 4\ kHz$) | AC 80 A | AC 95 A |
| Current limitation I_{max} | Motor and regenerative 150 % I_N , duration depending on capacity utilization | |
| Internal current limitation | $I_{max} = 0...150\ %$ adjustable | |
| Minimum permitted braking resistor value (4Q operation) R_{BRmin} | 3 Ω | |
| Output voltage U_A | Max. V_{supply} | |
| PWM frequency f_{PWM} | Can be set: 4/8/12/16 kHz | |
| Speed range/resolution $n_A / \Delta n_A$ | -6000 ... 0 ... +6000 rpm / 0.2 rpm across the entire range | |
| GENERAL INFORMATION | | |
| Power loss at S_N ¹⁾ P_{Vmax} | 1100 W | 1300 W |
| Cooling air consumption | 180 m ³ /h | |
| Weight | 26.3 kg (57 lb) | |
| Dimensions $W \times H \times D$ | 280 mm × 522 mm × 307mm (11.0 in × 20.6 in × 12.1 in) | |
| Cross section of unit terminals X1, X2, X3, X4 | M10 bolt with nut max. 70 mm ² Press cable lug DIN 46235 | |
| Tightening torque | 3.5 Nm | |

1) The performance data applies to $f_{PWM} = 4\ kHz$.

| MDX61B Standard version | 0220-203-4-00 | 0300-203-4-00 |
|---|-----------------------------|---------------|
| Part number | 828 001 0 | 828 002 9 |
| MDX61B Application version | 0220-203-4-0T | 0300-203-4-0T |
| Part number | 828 012 6 | 828 013 4 |
| Constant load Recommended motor power P_{Mot} | 22 kW (30 HP) | 30 kW (40 HP) |
| Variable torque load or constant load without overload Recommended motor power P_{Mot} | 30 kW (40 HP) | 37 kW (50 HP) |
| Recommended motor power | → section "Motor selection" | |

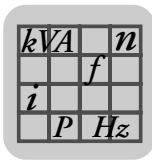

2.5 MOVIDRIVE® MDX60/61B electronics data

| MOVIDRIVE® MDX60/61B | | General electronics data | |
|---|--|--|---|
| Voltage supply for setpoint input | X11:1 X11:5 | REF1: DC+10 V +5 % / -0 %, I_{\max} = DC 3 mA REF2: DC-10 V +0 % / -5 %, I_{\max} = DC 3 mA | Reference voltages for setpoint potentiometer |
| Setpoint input n1 (differential input) Operating mode AI11/AI12 Resolution Internal resistance | X11:2/X11:3 | AI11/AI12: Voltage or current input, can be set with S11 and P11_, sampling interval 1 ms Voltage input: n1 = DC 0...+10 V or DC -10 V...0...+10 V 12 bit R_i = 40 k Ω (external voltage supply) R_i = 20 k Ω (supply from REF1/REF2) | Current input: n1 = DC 0...20 mA or DC 4...20 mA 11 bit R_i = 250 Ω |
| Internal setpoints | | Parameter set 1: n11/n12/n13 = -6000...0...+6000 rpm Parameter set 2: n21/n22/n23 = -6000...0...+6000 rpm | |
| Time ranges of the speed ramps at Δn = 3000 rpm | | 1. Ramp t11/t21 Up: 0...2000 s Down: 0...2000 s 2. Ramp t12/t22 Up = down: 0...2000 s Stop ramp t13/t23 Down: 0...20 s Emergency ramp t14/t24 Down: 0...20 s Motor potentiometer t3 Up: 0.2...50 s Down: 0.2...50 s | |
| Auxiliary voltage output ¹⁾ X13:8/X10:8 | | VO24: V_{OUT} = DC 24 V, maximum current carrying capacity I_{\max} = DC 400 mA | |
| External voltage supply ¹⁾ | X10:9 | VI24: U_{IN} = DC 24 V -15 % / +20 % according to EN 61131-2 | |
| Binary inputs X13:1...X13:6 and X16:1/X16:2 Internal resistance Signal level Function X13:1 X13:2...X13:6, X16:1/X16:2 | | Isolated (optocoupler), PLC compatible (EN 61131), sampling interval 1 ms DIØØ...DIØ5 and DIØ6/DIØ7 $R_i \approx 3$ k Ω , $I_E \approx$ DC 10 mA DC +13 V...+30 V = "1" = Contact closed DC-3 V...+5 V = "0" = Contact open according to EN 61131 DIØØ: fixed assigned with "/Controller inhibit" DIØ1...DIØ5, DIØ6/DIØ7: Selection option → Parameter menu P60_ | |
| Binary outputs ¹⁾ X10:3/X10:7 and X16:3...X16:5 Signal level Function X10:3 X10:7, X16:3...X16:5 | | PLC-compatible (EN 61131-2), response time 1ms DBØØ/DOØ2 and DOØ3...DOØ5 "0" = DC 0 V "1" = DC +24 V Caution: Do not apply external voltage! DBØØ: With fixed assignment "/Brake", I_{\max} = DC 150 mA, short-circuit proof, protected against external voltage to DC 30 V DOØ2, DOØ3...DOØ5: Selection option → Parameter menu P62_, I_{\max} = DC 50 mA, short-circuit proof, protected against external voltage to DC 30 V | |
| Relay output Function X10:4 X10:5 X10:6 | X10:4...X10:6 | DOØ1: Load capacity of the relay contacts U_{\max} = DC 30 V, I_{\max} = DC 800 mA DOØ1-C: Shared relay contact DOØ1-NO: Normally open contact DOØ1-NC: NC contact Selection option → Parameter menu P62_ | |
| System bus (SBus) | X12:1 X12:2 X12:3 | DGND: Reference potential SC11: SBus high SC12: SBus low | CAN bus according to CAN specification 2.0, parts A and B, transmission technology according to ISO 11898, max. 64 stations, terminating resistor (120 Ω) can be activated using DIP switches |
| RS485 interface | X13:10 X13:11 | ST11: RS485+ ST12: RS485- | EIA standard, 9.6 kBaud, max. 32 stations Max. cable length 200 m Dynamic terminating resistor with fixed installation |
| TF/TH/KTY input | X10:1 | TF1: Response threshold at $R_{TF} \geq 2.9$ k $\Omega \pm 10$ % | |
| Reference terminals Permitted cable cross section | X11:4 X12:1/X13:9/X16:6/X10:2/X10:10 X13:7 | AGND: Reference potential for analog signals and terminals X11:1 and X11:5 (REF1/REF2) DGND: Reference potential for binary signals, system bus, RS485 interface and TF/TH DCOM: Reference potential for binary inputs X13:1...X13:6 and X16:1/X16:2 (DIØØ...DIØ5 and DIØ6/DIØ7) One core per terminal: 0.20...2.5 mm ² (AWG 24...12) Two cores per terminal: 0.25...1 mm ² (AWG 22...17) | |

1) The unit provides a current of I_{\max} = DC 400 mA for the DC+24 V outputs (VO24, binary outputs). If this value is insufficient, a DC 24 V voltage supply must be connected to X10:9 (VI24).

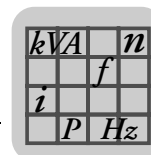

| MOVIDRIVE® MDX60/61B | General electronics data |
|--|--|
| Safety contact X17:1 X17:2 X17:3 X17:4 Permitted cable cross section Power consumption X17:4 Input capacitance X17:4 Time for restart Time to inhibit output stage | DGND: Reference potential for X17:3 VO24: : $V_{OUT} = DC\ 24\ V$, only to supply X17:4 of the same unit; it cannot be used to supply other units. SOV24: Reference potential for DC+24 V input "Safe stop" (safety contact) SVI24: DC+24 V input "Safe stop" (safety contact) One core per terminal: 0.08...1.5 mm ² (AWG 28...16) Two cores per terminal: 0.25 ... 1.0 mm ² (AWG 23...17) Size 0: 3 W Size 1: 5 W Size 2, 2S: 6 W Size 3: 7.5 W Size 4: 8 W Size 5: 10 W Size 6: 6 W Size 0: 27 µF Sizes 1...6: 270 µF $t_A = 200\ ms$ $t_S = 200\ ms$ |
| Signal level | DC +19.2 V...+30 V= "1" = Contact closed DC-30 V...+5 V = "0" = Contact open |

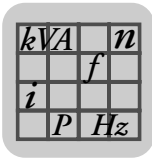

2.6 MOVIDRIVE® MDX60B dimension sheets

Size 0S

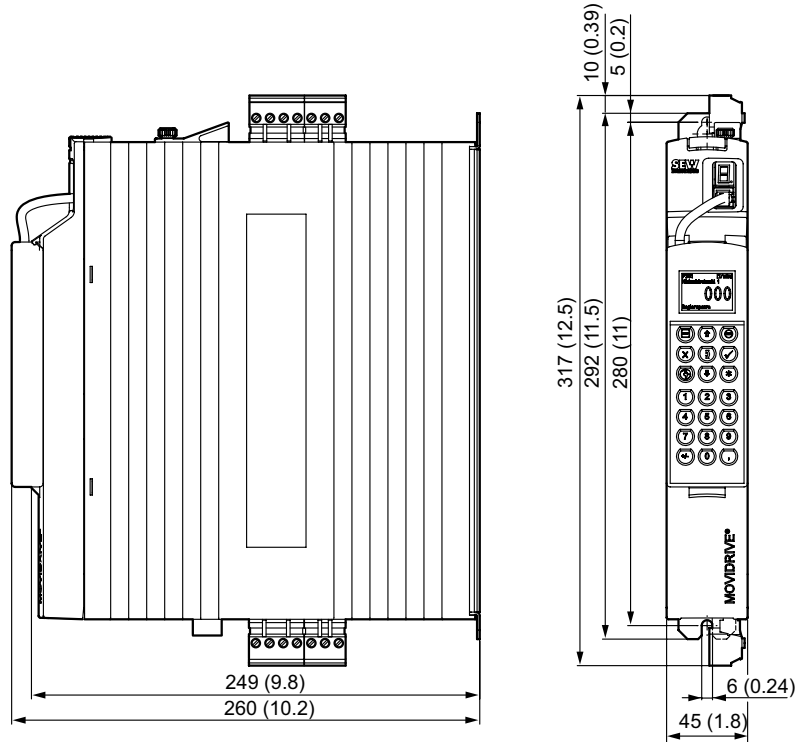

Figure 8: Dimensions for MDX60B size 0S, dimensions in mm (in)

53019CXX

Size 0S with
 braking resistor
 installed

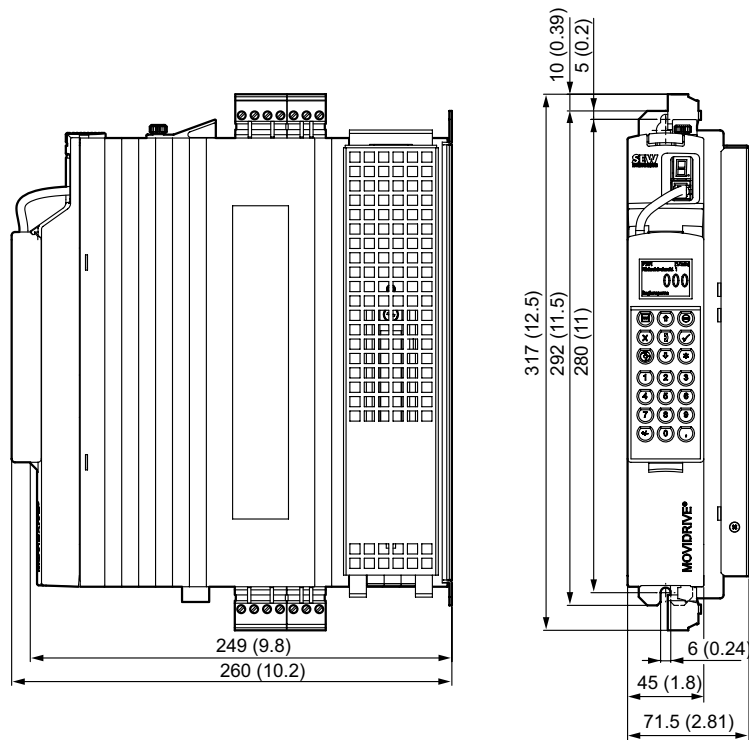

Figure 9: Dimensions for MDX60B size 0S with braking resistor, dimensions in mm (in)

53020CXX

Size 0M

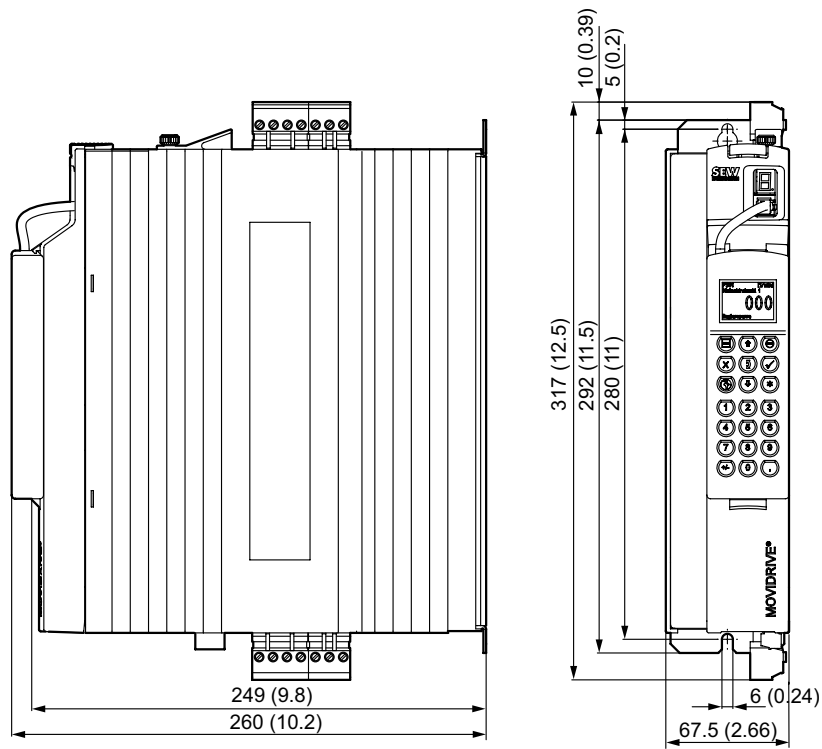

Figure 10: Dimensions for MDX60B size 0M, dimensions in mm (in)

53022CXX

Size 0M with
braking resistor

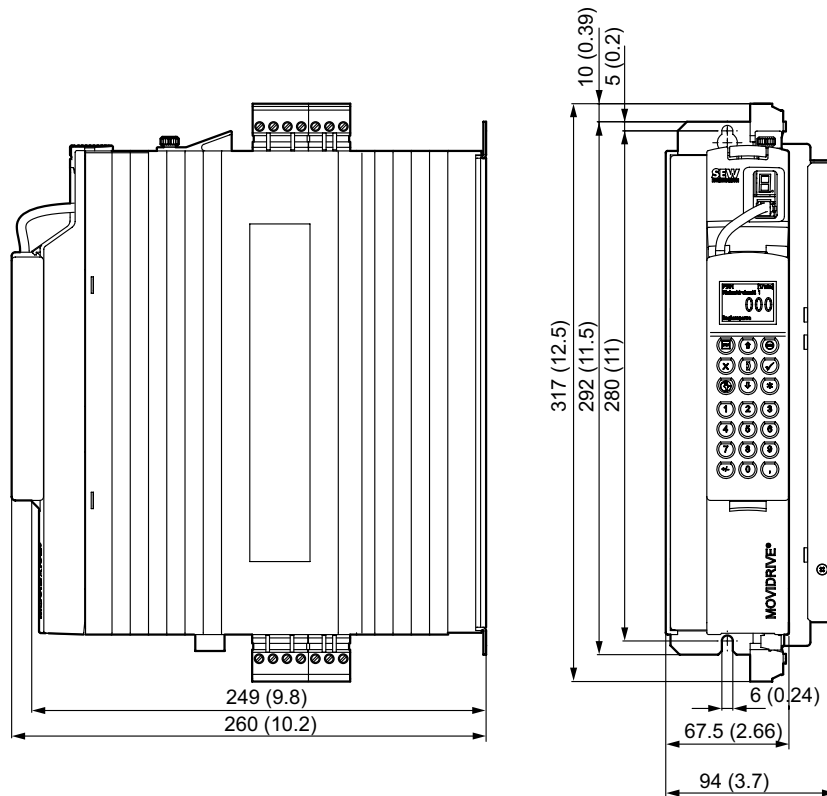
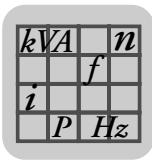

Figure 11: Dimensions for MDX60B size 0M with braking resistor, dimensions in mm (in)

53023CXX



2.7 MOVIDRIVE® MDX61B dimension sheets

| | |
|--|---|
| | <p>NOTE</p> <p>For MOVIDRIVE® MDX61B size 0, installing a braking resistor does not affect the dimensions. Therefore, MOVIDRIVE® MDX61B size 0 dimensions are displayed without an installed braking resistor.</p> |
|--|---|

Size 0S

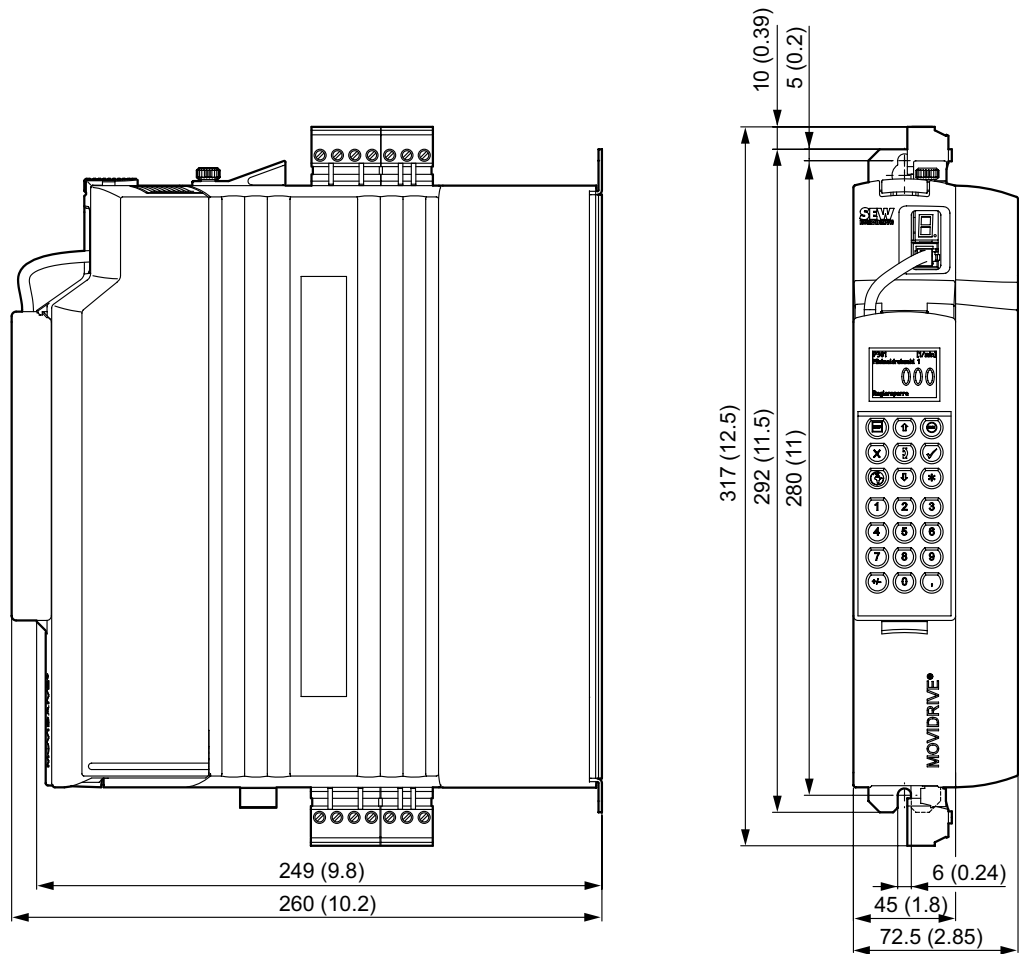

51381CXX

Figure 12: Dimensions for MDX61B size 0S, dimensions in mm (in)

| | |
|-----|----------------|
| kVA | n |
| i | f |
| P | H _Z |

Size 0M

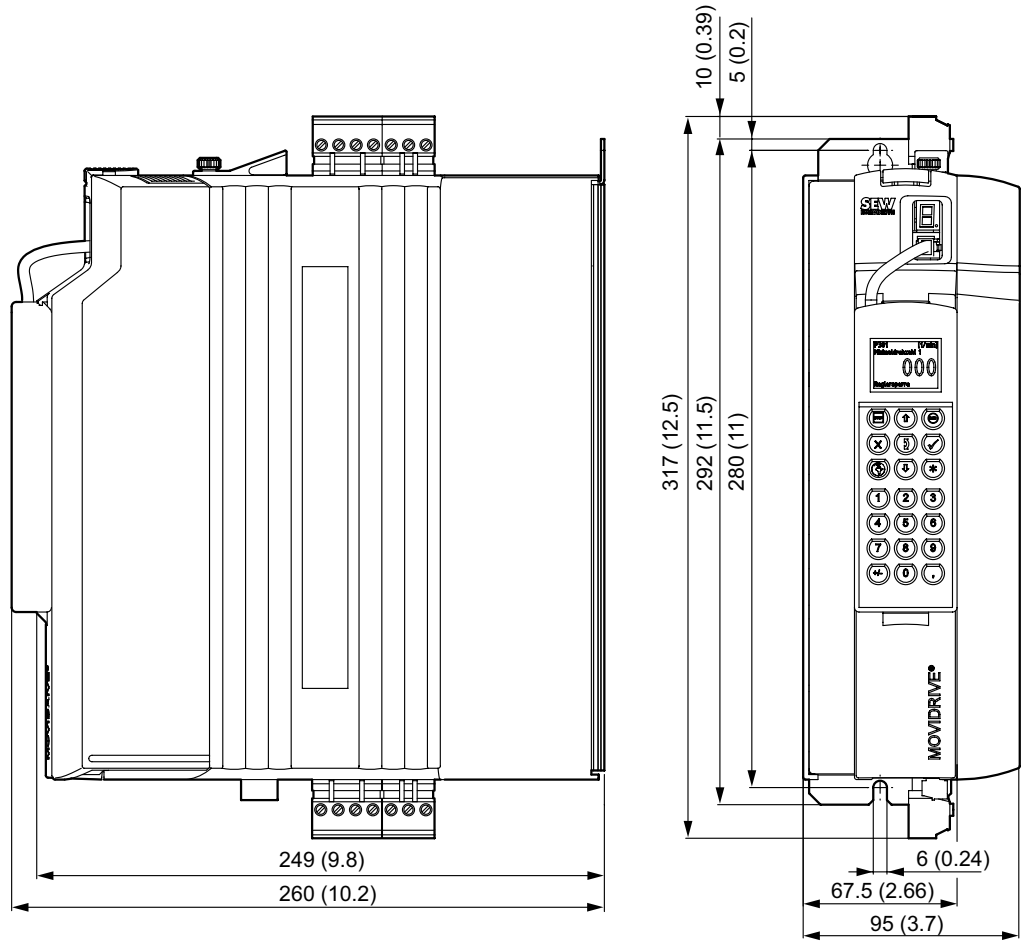

51378CXX

Figure 13: Dimensions for MDX61B size 0M, dimensions in mm (in)

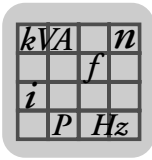

Size 1

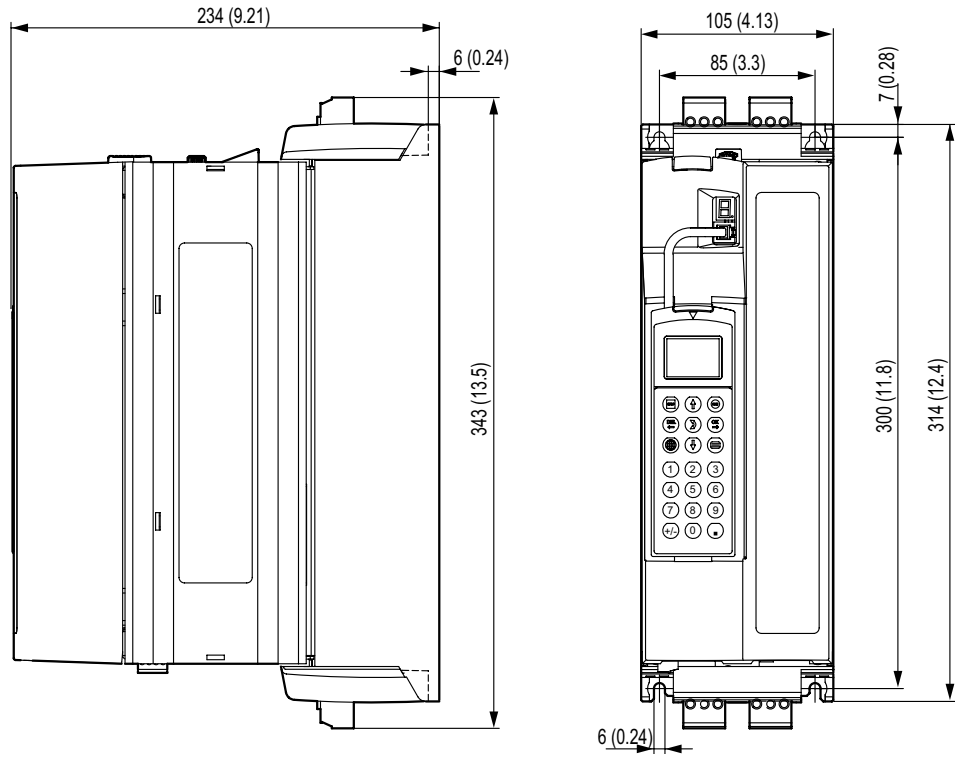

Figure 14: Dimensions for MDX61B size 1, dimensions in mm (in)

52274CXX

| | |
|-----|----|
| kVA | n |
| f | |
| i | |
| P | Hz |

Size 2S

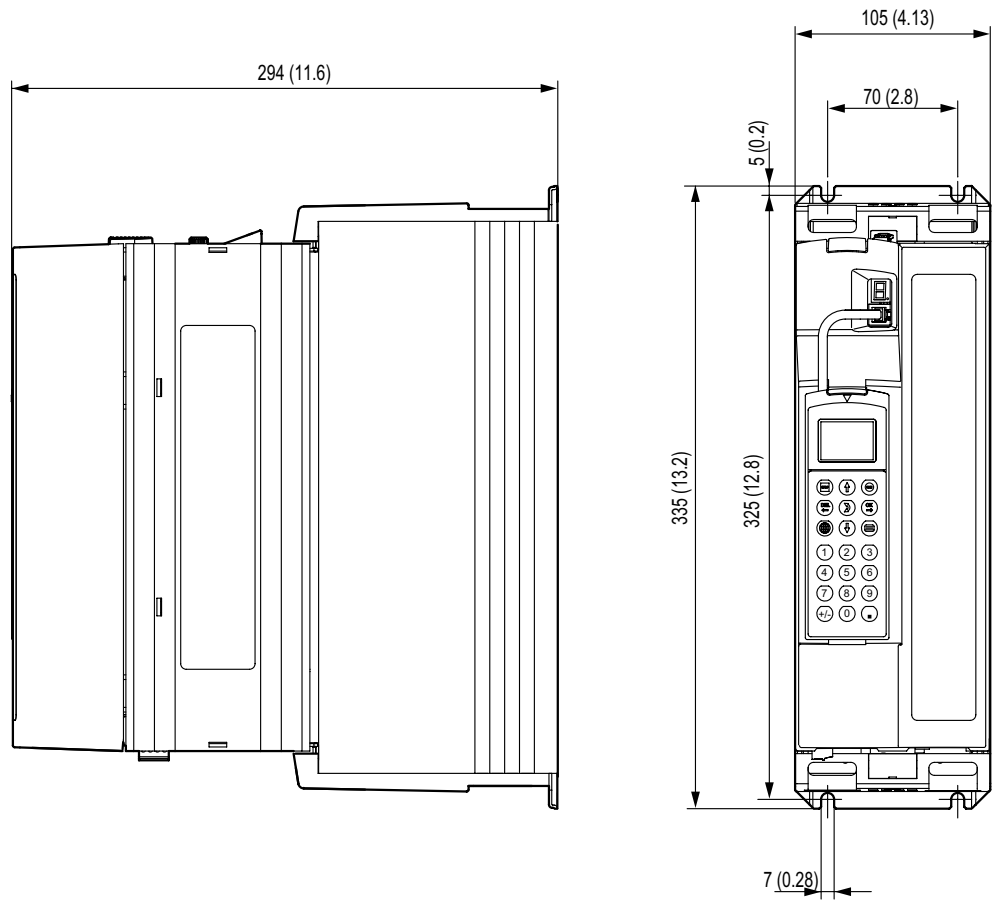
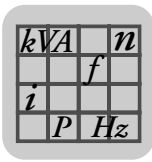
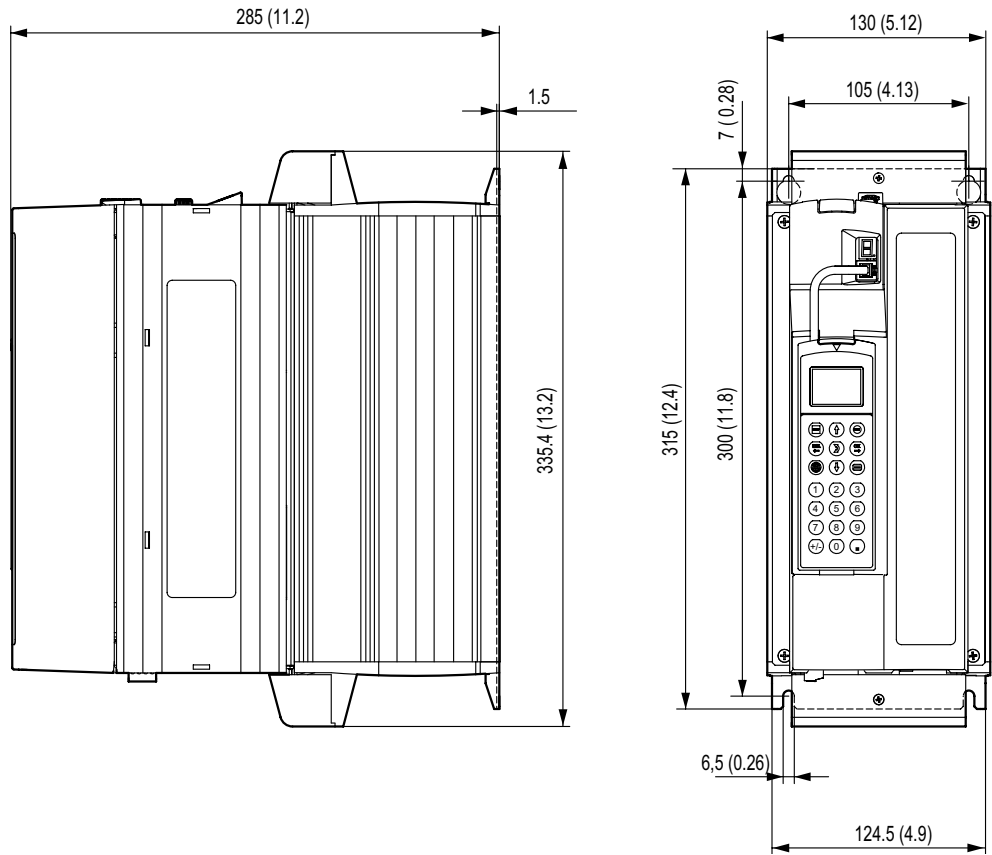

Figure 15: Dimensions for MDX61B size 2S, dimensions in mm (in)

52273CXX



Size 2



52276CXX

Figure 16: Dimensions for MDX61B size 2, dimensions in mm (in)

| | |
|-----|----|
| kVA | n |
| i | f |
| P | Hz |

Size 3

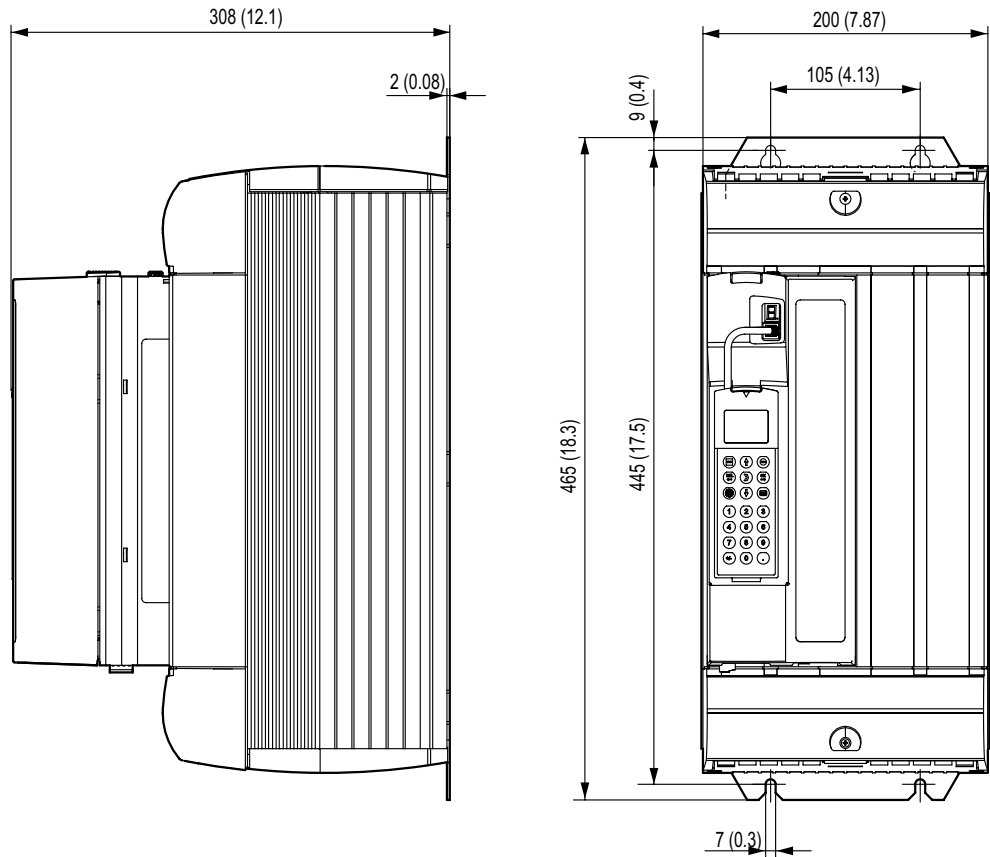
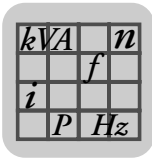

Figure 17: Dimensions for MDX61B size 3, dimensions in mm (in)

52315CXX



Size 4

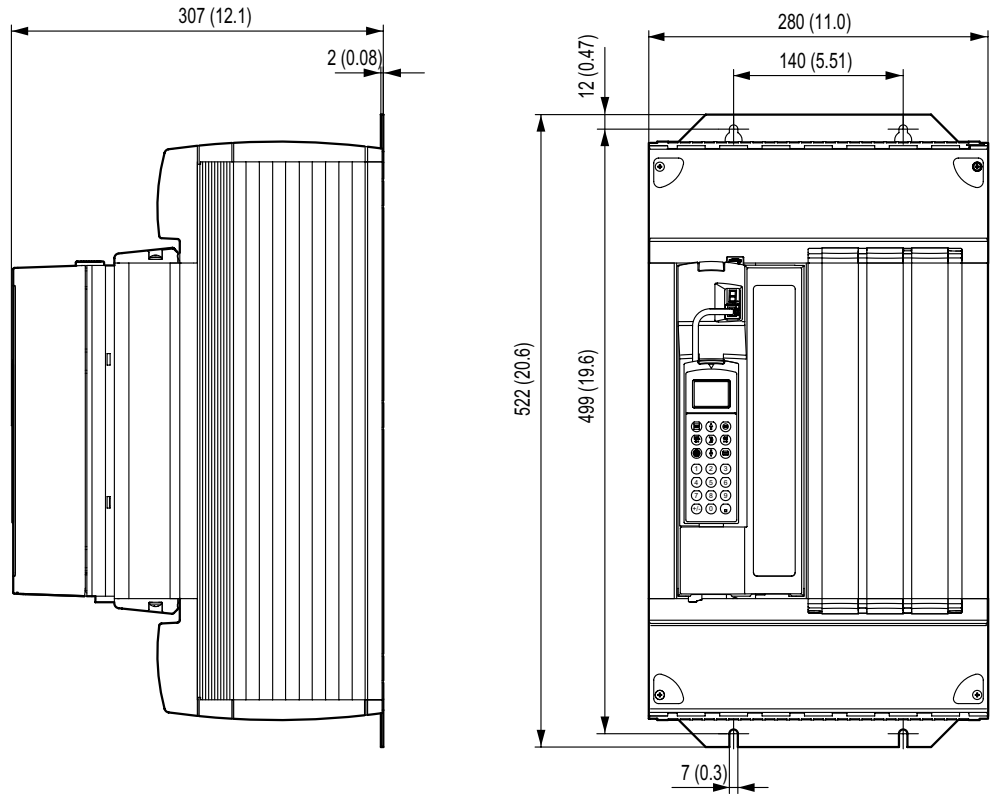

Figure 18: Dimensions for MDX61B size 4, dimensions in mm (in)

52277CXX

| | |
|-----|----------------|
| kVA | n |
| f | |
| i | |
| P | H _Z |

Size 5

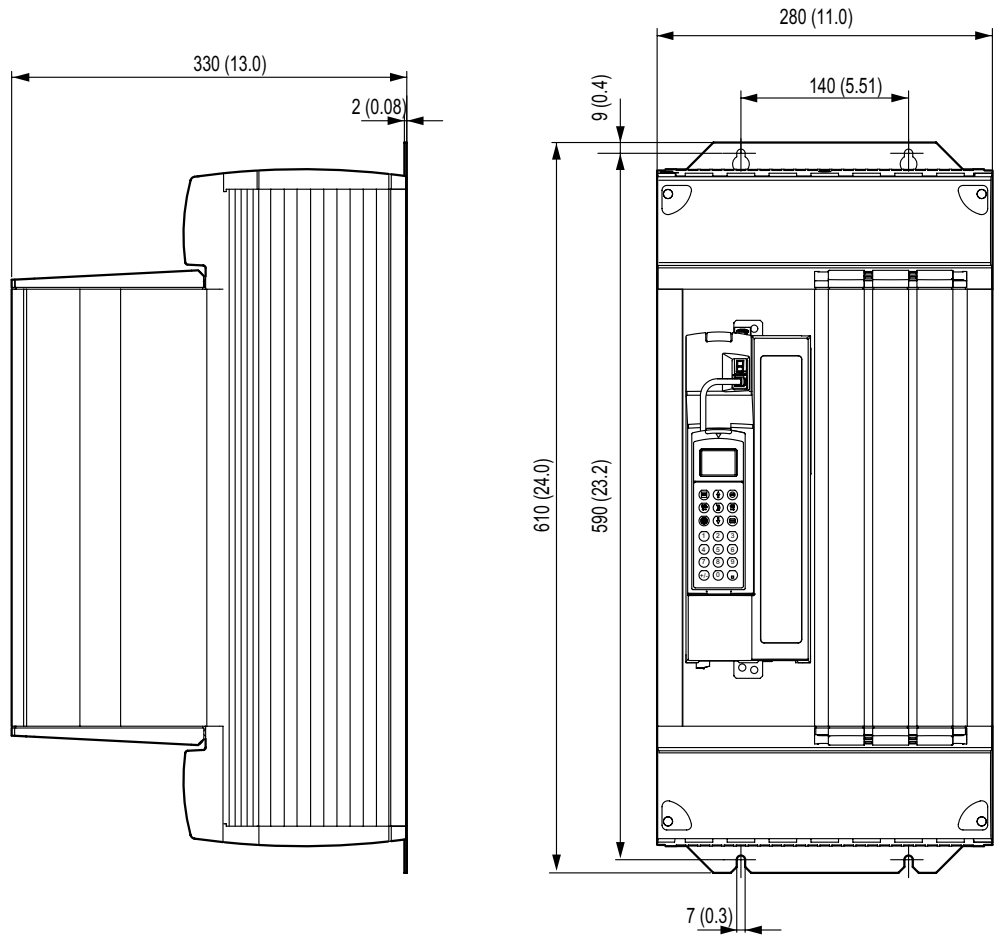
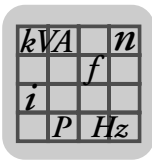
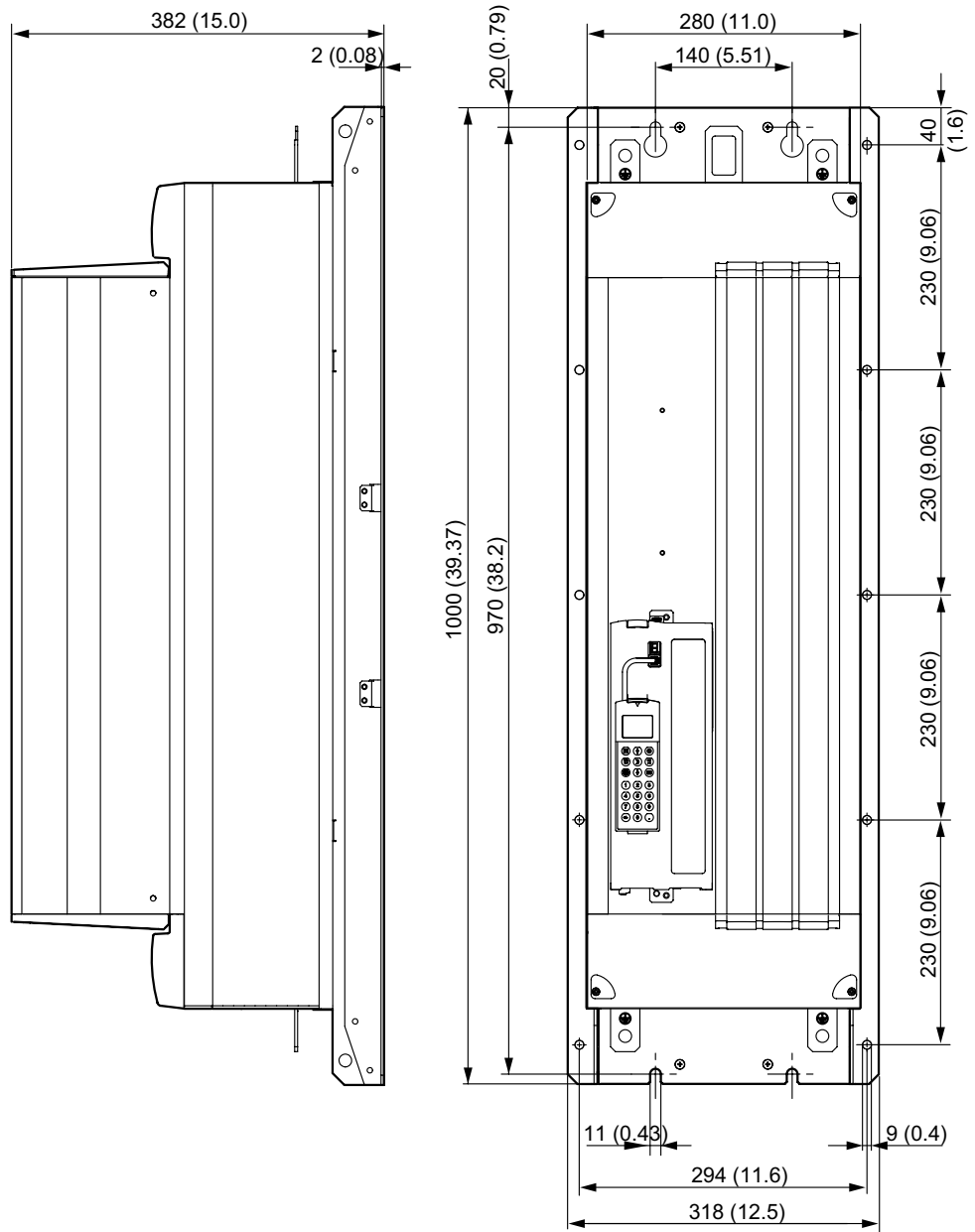

Figure 19: Dimensions for MDX61B size 5, dimensions in mm (in)

52278CXX



Size 6



58389CXX

Figure 20: Dimensions for MDX61B size 6, dimensions in mm (in)

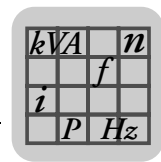

2.8 MOVIDRIVE® MDR60A regenerative power supply units

In MOVIDRIVE® inverters operating in regenerative mode (4Q operation), the MOVIDRIVE® MDR60A regenerative power supply unit can be used as an alternative to braking resistors. The prerequisite is a powerful supply system. For more detailed information, refer to the "MOVIDRIVE® MDR60A Regenerative Power Supply Unit" system manual. This manual can be ordered from SEW-EURODRIVE.

MOVIDRIVE® MDR60A supplies the DC link circuit of the connected MOVIDRIVE® inverter with electrical power from the supply system in motor operation and returns regenerative power to the supply system in regenerative operation.

UL approval



UL and cUL approval has been granted for the entire MOVIDRIVE® MDR60A0370-503-00 and MDR60A0750-503-00 range of units. cUL is equivalent to CSA approval. The MOVIDRIVE® MDR60A1320-503-00 unit does not have UL or cUL approval.

Protection and monitoring functions

- Monitoring and protection against thermal overload.
- Detection of power failure within one supply system half-wave.
- Overvoltage protection.



54512AXX

Figure 21: MOVIDRIVE® MDR60A regenerative power supply units

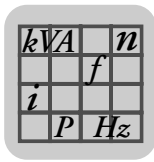

Features of a regenerative power supply unit compared to an inverter with braking resistors

- Energy balance: Regenerative power is fed back into the supply system instead of being converted into waste heat.
- Less installation work for several inverters (network and braking resistor connections). However, a braking resistor is required to bring the drive to a controlled stop even when there is a disruption in the supply system.
- Reduction in use of control cabinet capacity and ventilator power if the braking resistor used to have to be installed in the control cabinet.

General technical data

| MOVIDRIVE® MDR60A | 0370-503-00 (size 3) 0750-503-00 (size 4) | 1320-503-00 (size 6) |
|--|--|--|
| Interference resistance | Complies with EN 61800-3 | Meets EN 61000-6-1 and EN 61000-6-2 |
| Interference emission with EMC-compliant installation | Conforms to EN 61800-3 <ul style="list-style-type: none"> • With NF085-503 line filter (size 3) • With NF150-503 line filter (size 4) | Meets EN 61000-6-4 with line filter NF300-503 |
| Ambient temperature ϑ_U I_N reduction ambient temperature | 0 °C...+40 °C I_N reduction: 3 % I_N per K to max. 60 °C | 0 °C...+40 °C I_N reduction: 3 % I_N per K to max. 55 °C |
| Climate class | EN 60721-3-3, class 3K3 | |
| Storage temperature ¹⁾ ϑ_L | -25 °C...+70 °C (EN 60721-3-3, class 3K3) | -25 °C...+55 °C (EN 60721-3-3, class 3K3) |
| Cooling type (DIN 41751) | Forced cooling (temperature-controlled fan, response threshold 50 °C) | Forced cooling (temperature-controlled fan, response threshold 45 °C) |
| Degree of protection EN 60529 (NEMA1) Size 3 Size 4 | IP20 IP00 (power connections) IP10 (power connections) <ul style="list-style-type: none"> • With fitted plexiglass cover supplied as standard • With fitted shrink tubing (not included in scope of delivery) | IP20 |
| Duty cycle | Continuous duty with 50 % overload | |
| Overvoltage category | III according to IEC 60664-1 (VDE 0110-1) | |
| Pollution class | 2 according to IEC 60664-1 (VDE 0110-1) | |
| Installation altitude | Up to $h = 1000$ m (3281 ft) without restrictions. At $h \geq 1000$ m (3281 ft), the following restrictions apply: <ul style="list-style-type: none"> • from 1000 m (3281 ft) to max. 4000 m (13120 ft): <ul style="list-style-type: none"> – I_N reduction by 1% per 100 m (328 ft) • From 2000 m (6562 ft) to max. 4000 m (13120 ft): <ul style="list-style-type: none"> – U_N reduction by AC 6 V per 100 m (328 ft) Over 2000 m (6562 ft) only overvoltage class 2, external measures are required for overvoltage class 3. Overvoltage classes according to DIN VDE 0110-1. | $h \leq 1000$ m (3281 ft): No limitation from 1000 m (3281 ft) to max. 4000 m (13120 ft): I_N reduction: 0.5 % per 100 m (328 ft) |

1) In case of long-term storage, the unit must be connected to the mains voltage for at least 5 minutes, otherwise the unit's service life may be reduced.

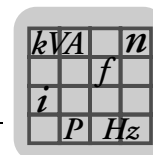

Technical data for MOVIDRIVE® MDR60A regenerative power supply

| MOVIDRIVE® MDR60A | 0370-503-00 (size 3) | 0750-503-00 (size 4) | 1320-503-00 (size 6) |
|--|---|--|--|
| Part number | 826 658 1 | 826 556 9 | 827 952 7 |
| INPUT | | | |
| Rated mains voltage (according to EN 50160) V_{supply} | 3 × AC 380 V - 500 V | | |
| Supply frequency f_{supply} | 50 Hz - 60 Hz ±5 % | | 40 Hz - 60 Hz ±10 % |
| Rated connected load P_N | 37 kW | 75 kW | 132 kW |
| Rated supply current (at $V_{\text{supply}} = 3 \times \text{AC } 400 \text{ V}$) I_{supply} | AC 66 A | AC 117 A | AC 260 A |
| DC LINK | | | |
| Apparent output power (at $U_{\text{supply}} = 3 \times \text{AC } 380..0.500 \text{ V}$) S_A | 50 kVA | 90 kVA | 173 kVA |
| DC link voltage $U_{\text{DC link}}$ | DC 560 V - 780 V | | |
| Rated DC link current $I_{\text{DC link}}$ | DC 70 A | DC 141 A | DC 340 A |
| Max. DC link current $I_{\text{DClink_max}}$ | DC 105 A | DC 212 A | DC 410 A |
| GENERAL INFORMATION | | | |
| Power loss at P_N $P_{V\text{max}}$ | 950 W | 1700 W | 2650 W |
| Cooling air consumption | 180 m ³ /h | 360 m ³ /h | 700 m ³ /h |
| Connection for power terminals X1, X2 (L1, L2, L3 for size 6) Permitted tightening torque Permitted cable cross section | M6 screw with washer 3.5 Nm (31 in-lb) 25 mm ² (AWG4) | M10 terminal studs 14 Nm (120 in-lb) 70 mm ² (AWG2/0) | M10 terminal studs 3.5 Nm 25 mm ² (AWG4) |
| Connection for DC link connection ±UG Permitted cable cross section Permitted tightening torque | - | - | 150 mm ² (power supply connection) / 30 Nm (270 in-lb) ¹⁾ 185 mm ² (power supply connection) / 32 Nm (280 in-lb) ¹⁾ |
| Connection for electronics terminals X3 (X2 for size 6) | Permitted cable cross section: • One conductor per terminal: 0.20...2.5 mm ² (AWG24...13) • Two conductors per terminal: 0.25...1 mm ² (AWG23...17) | | Permitted cable cross section: • 0.8...4 mm ² (AWG18...12) |
| Weight | 16 kg (35 lb) | 24 kg (53 lb) | 90 kg (200 lb) |
| Dimensions $W \times H \times D$ | 200 mm × 465 mm × 221 mm (7.87 in × 18.3 in × 8.7 in) | 280 mm × 522 mm × 205 mm (11 in × 20.6 in × 8.07 in) | 380 mm × 937 mm × 395 mm (15 in × 36.9 in × 15.6 in) |
| Line choke (always required) | ND085-013 $L_N = 0.1 \text{ mH}$ Part number 826 014 1 | ND200-0033 $L_N = 0.03 \text{ mH}$ Part number 826 579 8 | Already installed |
| Line filter (optional) | NF085-503, part number 827 415 0 | NF150-503, part number 827 417 7 | NF300-503, part number 827 419 3 |
| For MOVIDRIVE® MDX60B/61B...-5_3 | 0005 ... 0370 | 0005 ... 0750 | 0005 ... 1320 |

1) Important: Do not apply tightening torque directly at terminals L1, L2, L3 and ±UG; use a second wrench.

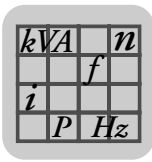

Dimension drawings for MDR60A

Provide at least 100 mm clearance above and below the unit. There is no need for clearance at the sides. You can line up the units directly next to one another. With sizes 4 and 6, do not install any components that are sensitive to high temperatures within 300 mm (11.8 in) of the top of the unit, for example contactors or fuses.

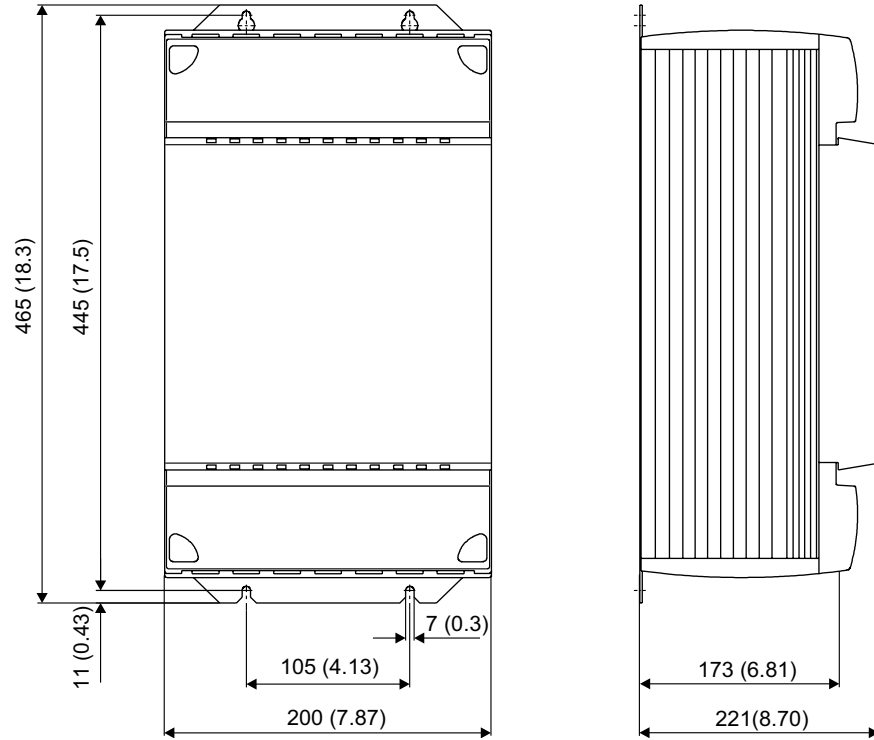

Figure 22: Dimension drawing, MDR60A size 3, dimensions in mm (in)

54260CXX

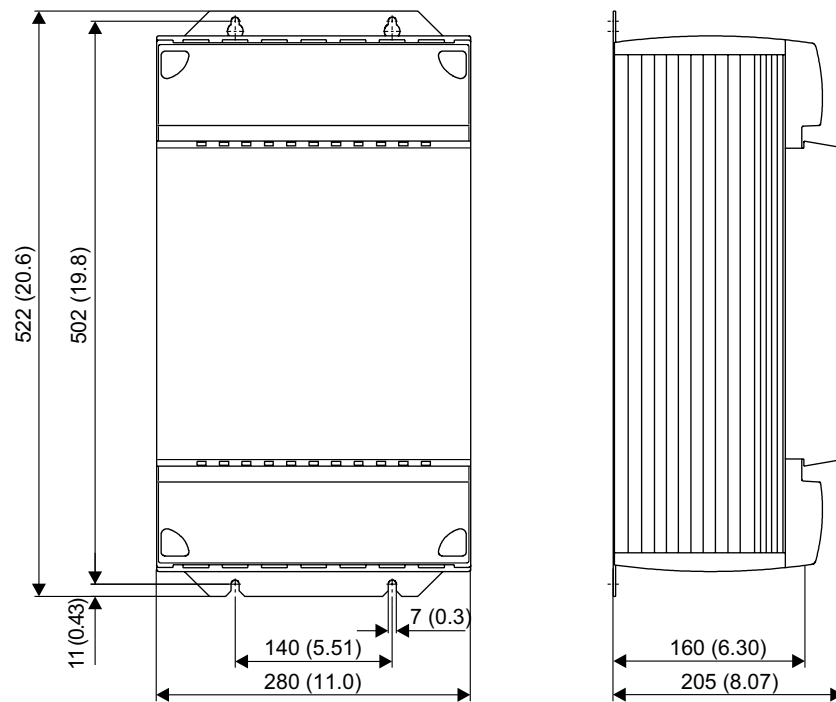
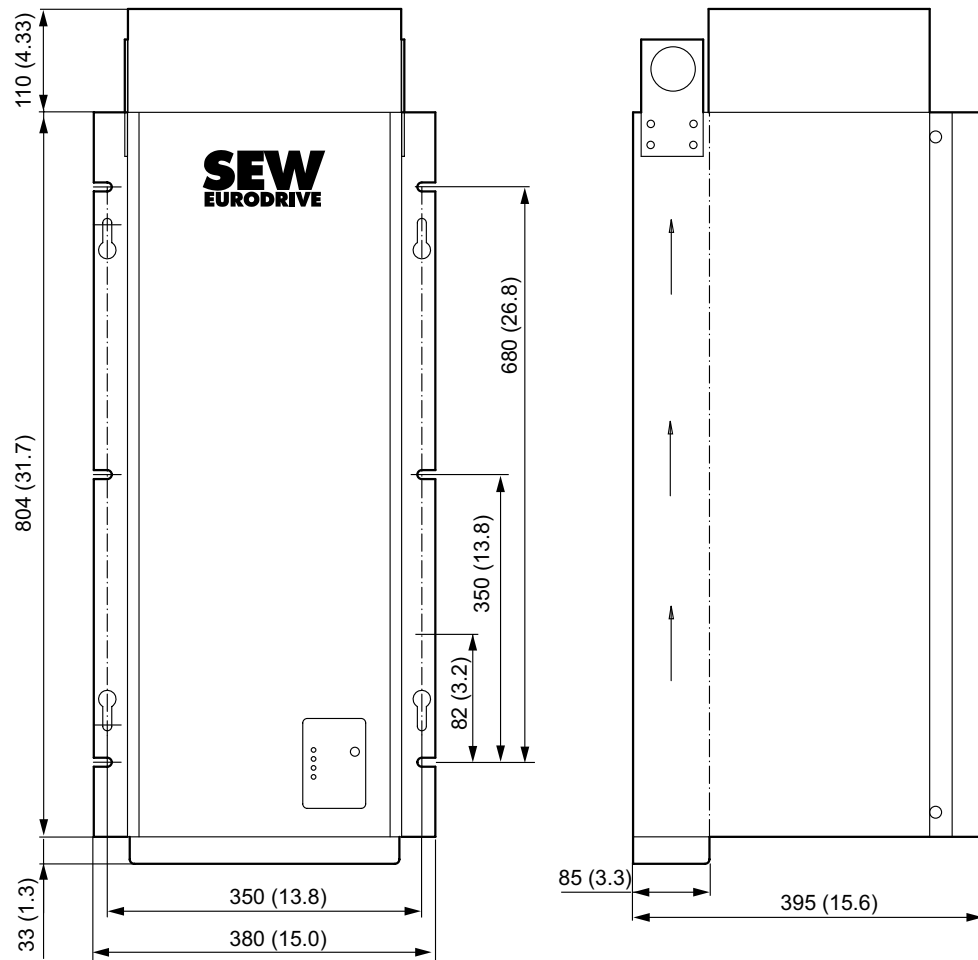
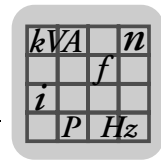

Figure 23: Dimension drawing, MDR60A size 4, dimensions in mm (in)

54261CXX



54282CXX

Figure 24: Dimension drawing, MDR60A size 6, dimensions in mm (in)

DC link connection

SEW-EURODRIVE recommends using the following cable sets for the DC link connection. These cable sets offer the appropriate dielectric strength and are also color-coded. Color coding is necessary because cross-polarity and ground faults could cause irreparable damage to the connected equipment.

The length of the cables restricts the DC link connection to the permitted length of 5 m. They can also be cut to length by the customer for connecting several units. The lugs for connection to the regenerative power supply unit and an inverter are supplied with the cable set. Use commercially available lugs for connecting additional inverters. The inverters must then be connected to the regenerative power supply unit in star configuration.

| Cable set type | DCP12A | DCP13A | DCP15A | DCP16A |
|---------------------------|---------------|---------------|---------------|---------------|
| Part number | 814 567 9 | 814 250 5 | 814 251 3 | 817 593 4 |
| For connecting MOVIDRIVE® | 0005 ... 0110 | 0150 ... 0370 | 0450 ... 0750 | 0900 ... 1320 |



NOTE

Refer to the "MOVIDRIVE® MDR60A Regenerative Power Supply Unit" system manual for information on the DC link connection. This manual can be ordered from SEW-EURODRIVE.

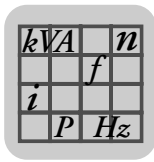

2.9 IPOSplus®

Description

IPOSplus® positioning and sequence control is integrated into every MOVIDRIVE® inverter as standard. With IPOSplus®, control functions and positioning tasks can be performed either simultaneously or independently of one another.

The IPOSplus® sequence control system makes it possible to run a user program, disregarding any encoder feedback or the selected control mode (VFC, CFC, SERVO). In conjunction with encoder feedback, the IPOSplus® positioning control provides high-performance point-to-point positioning. The IPOSplus® program is written using the MOVITOOLS® software. Starting up the inverter, accessing parameters and editing variables are all possible either with the operating software or the DBG60B keypad (startup in VFC mode only).

Features

- Program execution independent of encoder feedback and operating mode
- The user program is continued even if a unit malfunction occurs (troubleshooting is possible in the user program)
- Three user programs can be run in parallel and independently of one another (task 1, task 2 and task 3, each of them interrupt-capable)
- The user programs programmed in assembler can contain up to 3200 program lines
- User-friendly and comprehensive control options for the inverter
- Access to all available options
- Extensive options for communication via system bus (SBus), RS485, RS232 and fieldbus (direct communication with MOVIMOT® is possible)
- Processing of digital and analog input/output signals
- Positioning with selectable travel speed, positioning ramp and jerk limitation
- Feedforward for position, speed and torque control loops with minimized lag error
- Two touch probe inputs
- Ramp types: LINEAR, JERK LIMITED, SINE and SQUARE
- Status and monitoring functions: Lag error monitoring, position signal, software and hardware limit switches
- Nine types of reference travel
- Possibility of changing the target position, travel speed, positioning ramp and torque while movement is in progress
- Possibility of "Endless positioning"
- Override function
- Cam control
- Synchronous operation and electronic cam

With encoder feedback only

| Max. program length of task 1, task 2 and task 3 | Total of ca. 3200 program lines |
|--|--|
| Command processing time per program line | Task 1, 2: 1 ... 11 commands/ms can be configured Task 3: At least 1 command/ms (typical is 40 commands/ms) |
| Variables | 1024, of which 128 (0 ... 127) can be stored to non-volatile memory; range of values: $-2^{31} \dots +(2^{31}-1)$ |
| Touch probe inputs | 2 inputs, processing time < 100 µs |
| Sampling interval of digital and analog inputs | 1 ms |
| Digital inputs/outputs | 8 inputs / 5 outputs |
| Analog inputs/outputs | 1 input (DC 0...10 V, DC±10 V, DC 0...20 mA, DC 4...20 mA) 1 input (DC 0...10 V) 1 output (DC 0...20 mA, DC 4...20 mA) |

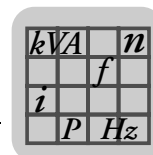

2.10 DBG60B keypad option

Description The basic version of MOVIDRIVE® does not have a DBG60B keypad and can be upgraded to include the keypad as an option.

| Keypad | Language variants | Part number |
|--|--|--------------------|
|  <p>56555AXX</p> | DBG60B-01 DE/EN/FR/IT/ES/PT/NL (German / English / French / Italian / Spanish / Portuguese / Dutch) | 1820 403 1 |
| | DBG60B-02 DE / EN / FR / FI / SV / DA / TR (German / English / French / Finnish / Swedish / Danish / Turkish) | 1820 405 8 |
| | DBG60B-03 DE/EN/FR/RU/PL/CS (German / English / French / Russian / Polish / Czech) | 1820 406 6 |
| | DBG60B-04 DE / EN / FR / ZH (German / English / French / Chinese) | 1820 850 9 |
| Door installation set¹⁾ | Description (= scope of delivery) | Part number |
| DBM60B | <ul style="list-style-type: none"> Housing for DBG60B (IP65) DKG60B extension cable, length 5 m | 824 853 2 |
| Extension cables | Description (= scope of delivery) | Part number |
| DKG60B | <ul style="list-style-type: none"> Length 5 m 4-core, shielded cable | 817 583 7 |

1) The DBG60B keypad is not included in the scope of delivery and must be ordered separately.

Functions

- Display process values and status
- Status displays of the binary inputs / outputs
- Error memory and error reset queries
- Option to display and set the operating parameters and service parameters
- Data backup and transfer of parameter sets to other MOVIDRIVE® units.
- User-friendly startup menu for VFC mode
- Manual control of MOVIDRIVE® B and MOVITRAC® B
- Manual operation of MOVIMOT® (→ Decentralized technology documentation)

Features

- Illuminated text display, range of languages
- Keypad with 21 keys
- Selection between user menu, detailed parameter menu and startup menu in VFC mode (CFC and SERVO startup is not possible with the DBG60B)
- Can be plugged into MOVIDRIVE®
- Can be connected via extension cable DKG60B (5 m [16.4 ft])
- Degree of protection IP40 (EN 60529)

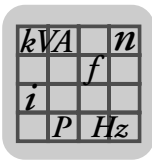

| | |
|---|--|
|  | NOTE |
| | The DBG60B keypad option and the interface adapter are plugged into the same inverter slot (XT) and therefore cannot be used at the same time. |

Dimension drawing for DBG60B

Dimensions in mm (in)

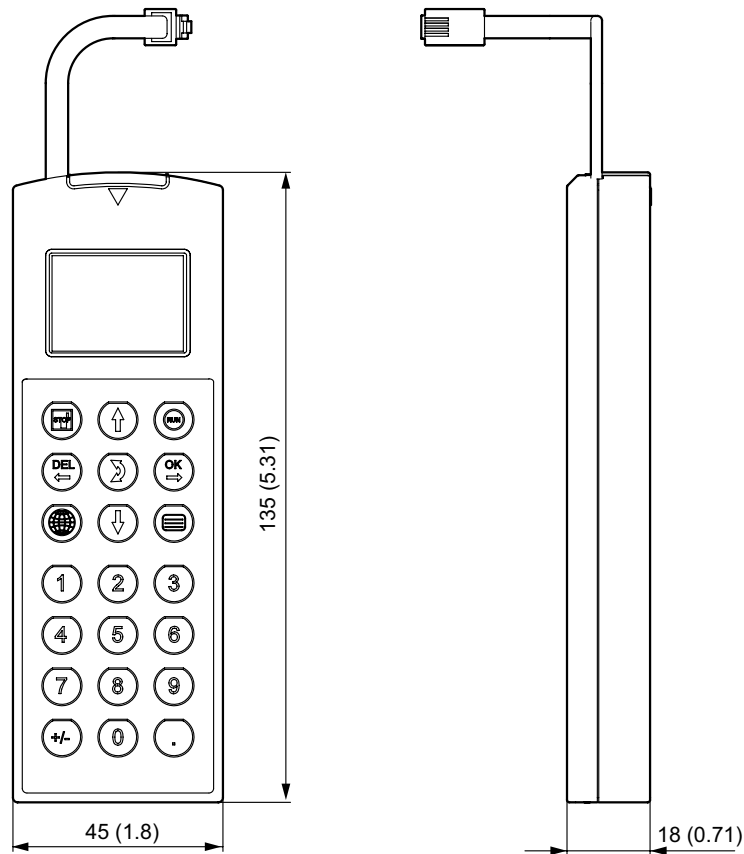

53147CXX

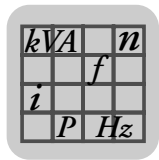

Dimension drawing for DBG60B housing

The DBM60B option can be used to mount the keypad close to the inverter (e.g. in the control cabinet door). The DBM60B option consists of housing in enclosure IP65 and a 5 m DKG60B extension cable.

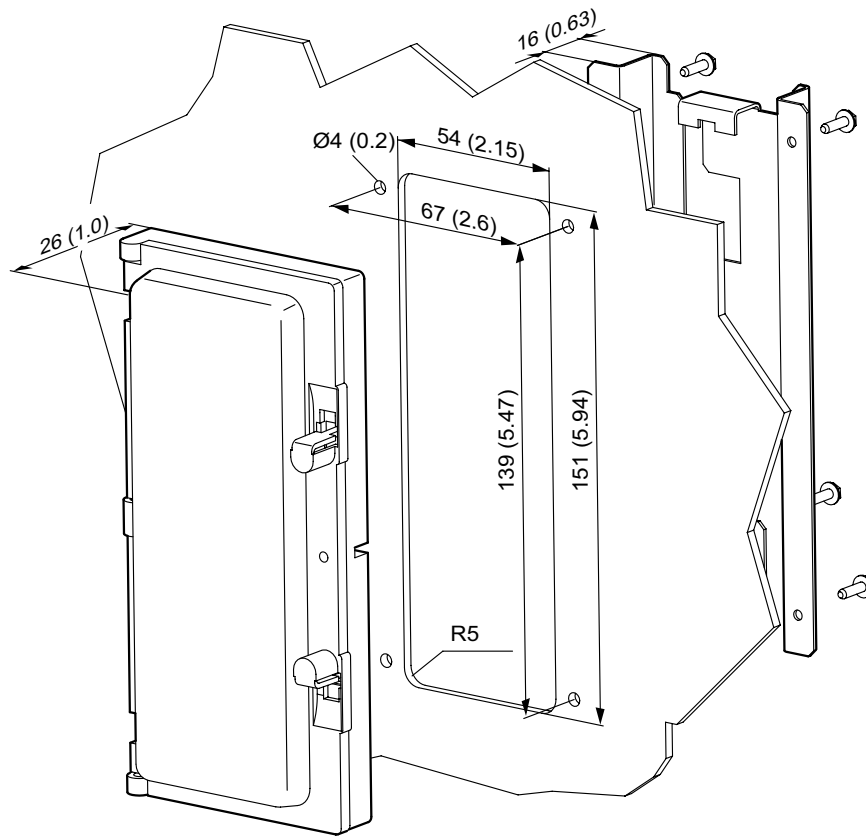
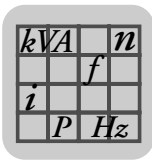

Figure 25: Dimension drawing for DBG60B housing, dimensions in mm (in)

62899AXX



2.11 DMP11B mounting panel option

Part number 818 398 8

Description

DMP11B

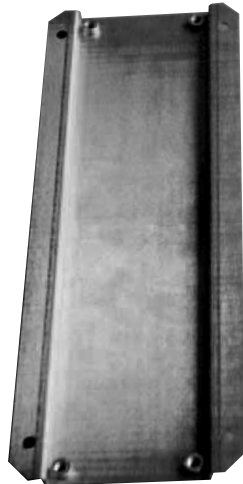

54588AXX

If a MOVIDRIVE® MD_60A size 2 unit is to be replaced by MOVIDRIVE® MDX61B size 2S, the MDX61B size 2S can be fitted on the existing mounting plate with the DMP11B mounting panel. New retaining holes do not have to be drilled.

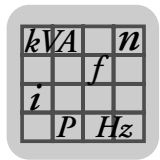

2.12 DLB11B touch guard option

Part number 823 111 7 (12 pieces included in the scope of delivery)

Description

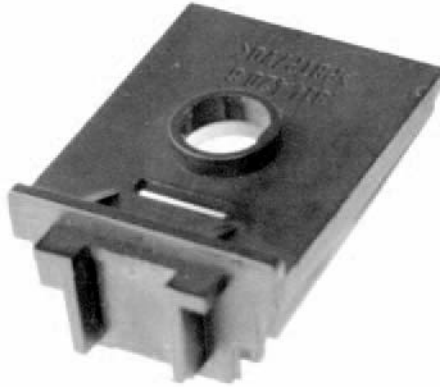

63233AXX

Degree of protection IP20 can be achieved with touch guard DLB11B for MOVIDRIVE[®] MDX61B sizes 4 and 5 (AC 500 V units: MDX61B0370/0450/0550/0750; AC 230 V units: MDX61B0220/0300).

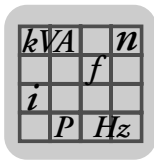

2.13 HIPERFACE® encoder card option type DEH11B

Part number 824 310 7

Description The option capable MOVIDRIVE® MDX61B units can be equipped with the HIPERFACE® encoder card type DEH11B. The encoder card offers one input for the motor encoder and one input for an external encoder, also referred to as synchronous encoder. The input for the external encoder can also be used as an output for incremental encoder simulation.

Electronics data

| Option DEH11B | |
|--|--|
|  | <p>Output for incremental encoder simulation or external encoder input X14:</p> |
| | <p>Output for incremental encoder simulation:</p> <ul style="list-style-type: none"> • Signal level to RS422 • The number of pulses is the same as on X15 motor encoder input |
| <p>Motor encoder input X15:</p> | <p>External encoder input (max. 200 kHz):</p> <p>Permitted encoder types:</p> <ul style="list-style-type: none"> • HIPERFACE® encoder • sin/cos encoder AC 1 V_{SS} • TTL encoder with negated tracks • Encoder with signal level to RS422 <p>Encoder power supply:</p> <ul style="list-style-type: none"> • DC+12 V (tolerance range DC 10.5 - 13 V) • I_{max} = DC 650 mA¹⁾ |
| | <p>Permitted encoder types:</p> <ul style="list-style-type: none"> • HIPERFACE® encoder • sin/cos encoder AC 1 V_{SS} • TTL encoder with negated tracks • Encoder with signal level to RS422 • Permitted resolution: 128/256/512/1024/2048 increments <p>Encoder power supply:</p> <ul style="list-style-type: none"> • DC+12 V (tolerance range DC 10.5 - 13 V) • I_{max} = DC 650 mA¹⁾ |

1) Total current load of DC 12 V encoder supply ≤ DC 650 mA.

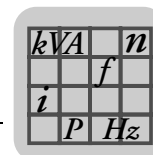

2.14 Absolute encoder card option type DEH21B/DIP11B

- Part numbers**
- DEH21B: 1820 818 5
 - DIP11B: 824 969 5

Description

The DEH21B and DIP11B options extend the MOVIDRIVE® B system to include an SSI interface for absolute encoders. This option allows the following possibilities for IPOS^{plus}® positioning:

- No reference travel required when the system is started or after a power failure
- Positioning can take place either with the absolute encoder or the incremental encoder/resolver installed on the motor.
- No position switch needed on the travel distance, even without motor encoder feedback
- Free processing of the absolute position in the IPOS^{plus}® program
- In addition to the basic unit, 8 digital inputs and 8 digital outputs are available with the DIP1B option.
- The absolute encoder can be mounted either on the motor or along the track (e.g. high-bay warehouse)
- Simple encoder adjustment with user-guided startup
- Endless positioning in combination with activated modulo function

Electronics data for DEH21B

| DEH21B option | | |
|---------------|-------------------------------|---|
| | Motor encoder connection X15: | Permitted encoder types: <ul style="list-style-type: none"> • HIPERFACE® encoder • sin/cos encoder AC 1 V_{SS} • TTL encoder with negated tracks • Encoder with signal level to RS422 • Permitted resolution: 128/256/512/1024/2048 increments Encoder power supply: , <ul style="list-style-type: none"> • DC+12 V (tolerance range DC 10.5 ... 13 V) • I_{max} = DC 650 mA |
| | Encoder connection X62: | SSI encoder input |
| | Power supply connection X60:1 | 24VIN: DC 24 V power supply for encoder connected to X62 |
| | Reference terminal X60:2 | Reference potential 24VIN |

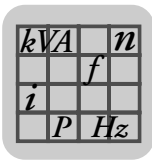

Electronics data for DIP11B

| DIP11B option | | |
|-----------------|--|--|
| <p>11884AXX</p> | Connection binary inputs X60:1 ... 8 Internal resistance Signal level (EN 61131) Function X60:1 ... 8 | DI10 ... DI17 isolated via optocoupler, PLC compatible (EN 61131), scanning time 1 ms $R_i \approx 3 \text{ k}\Omega$, $I_E \approx \text{DC } 10 \text{ mA}$ DC+13 V ... +30 V = "1" / DC-3 V ... +5 V = "0" DI10 ... DI17: Selection option → Parameter menu P61_ |
| | Connection binary outputs X61:1 ... 8 Signal level (EN 61131) Function X61:1 ... 8 | DO10 ... DO17, PLC-compatible (EN 61131), short-circuit proof and protected against external voltage to DC 30 V Response time 1 ms DC +24 V = "1" DC 0 V = "0" Important: Do not apply external voltage! DO10 ... DO17: Selection option → Parameter menu P63_ |
| | Encoder connection X62: | SSI encoder input |
| | Reference terminals X60:9 X60:10 Permitted line cross section | DCOM: Reference potential for binary inputs (DI10 ... DI17) DGND: Reference potential for binary signals and 24VIN • without jumper X60:9-X60:10 (DCOM-DGND) isolated binary inputs • With jumper X60:9-X60:10 (DCOM-DGND) non-isolated binary inputs One core per terminal: 0.08 ... 1.5 mm ² (AWG28 ... 16) Two cores per terminal: 0.25 ... 1 mm ² (AWG22 .. 17) |
| | Voltage input X61:9 | 24VIN: Supply voltage DC+24 V for binary outputs DO10 ... DO17 and encoder (mandatory) |

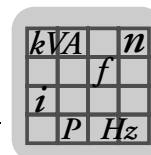

2.15 Resolver card option type DER11B

Part number 824 307 7

Description

Option-capable MOVIDRIVE® MDX61B units can be equipped with resolver card type DER11B. The resolver card offers one input for the resolver as motor encoder and one input for an external encoder, also referred to as synchronous encoder. The input for the external encoder can also be used as an output for incremental encoder simulation.

Electronics data

| DER11B option | | | |
|---------------|--|---|---|
| | Output for incremental encoder simulation or external encoder input X14: | Output for incremental encoder simulation: Signal level to RS422 The number of pulses is 1024 pulses/revolution | External encoder input (max. 200 kHz): Permitted encoder types: <ul style="list-style-type: none"> HIPERFACE® encoder sin/cos encoder AC 1 V_{SS} TTL encoder with negated tracks Encoder with signal level to RS422 Encoder power supply: <ul style="list-style-type: none"> DC+12 V (tolerance range DC 10.5 - 13 V) I_{max} = DC 650 mA |
| | Motor encoder input X15: | Resolver 2-pole, U _{ref} = AC 3.5 V _{eff} , 4 kHz U _{in} / U _{ref} = 0.5 | |
| | Maximum cable length: | 100 m (328 ft) | |

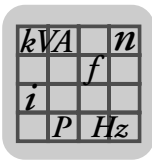

2.16 Connector adapter for unit replacement MD_60A - MDX60B/61B

The following adapters are available for rapid replacement of a MOVIDRIVE® A unit with a MOVIDRIVE® B unit during system operation.

- DAT11B: Terminal adapter, part number 824 671 8

If the TF/TH option is connected to X10 when using MOVIDRIVE® MD_A, then X10 can be directly replugged. The jumper between X10:1 and X10:2 must be removed if a TF/TH option is connected to encoder input X15. Three plugs have to be rewired. You can avoid such rewiring work by using the DAT11B terminal adapter. Using this adapter will prevent incorrect connection and save time. The terminal adapter is required for terminals X11 (analog input), X12 (SBus) and X13 (binary inputs).

DAT11B

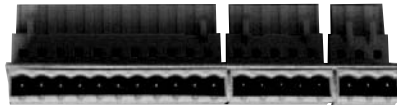

54589AXX

- DAE15B: Encoder adapter X15, part number 817 629 9

If a motor with encoder on X15 is in operation on an MDV or MCV, the encoder is connected via a 9-pin plug connector to MOVIDRIVE® A. Since the DEH11B option for MOVIDRIVE® MDX61B comes equipped with a 15-pin socket, you will either have to convert the encoder cable or use the encoder adapter. The encoder adapter DAE15B for connecting sin/cos and TTL encoders can be inserted directly between the existing encoder cable with a 9-pin connector and the 15-pin socket on DEH11B. This step makes for fail-safe and fast connection of existing drives. HTL encoders have to be connected to MOVIDRIVE® B with the DWE11B/12B option (→ section "DWE11B/12B interface adapter option).

DAE15B



54585AXX

Length of DAE15B: 200 mm ± 20 mm (7.87 in ± 0.79 in)

Cable cross section: 6 x 2 x 0.25 mm² (AWG 23)

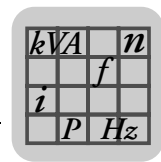

| Terminal of the 15-pin sub D connector (MOVIDRIVE® MDX61B, option DEH11B, X15) | Core color in prefabricated cable | Terminal of 9-pin sub D socket (encoder end) |
|--|-----------------------------------|--|
| 1 | Yellow (YE) | 1 |
| 2 | Red (RD) | 2 |
| 3 | Pink (PK) | 3 |
| 4 | Violet (VT) | 4 |
| 8 | Brown (BN) | 5 |
| 9 | Green (GN) | 6 |
| 10 | Blue (BU) | 7 |
| 11 | Gray (GY) | 8 |
| 15 | White (WH) | 9 |

- DAE14B: Encoder adapter X14, part number 817 630 2
If a synchronous encoder at X14 is operated on a MOVIDRIVE® MDV, MDS, MCV or MCS unit, connection takes place via a 9-pin socket. Since the DEH11B and DER11B options for MOVIDRIVE® MDX61B come equipped with a 15-pin plug, you will either have to rework the encoder cable or use the DAE14B encoder adapter. The DAE14B encoder adapter can be plugged directly between the existing encoder cable with 9-pin socket and the 15-pin connector on the DEH11B//DER11B option. This step makes for fail-safe and fast connection of existing drives.

DAE14B

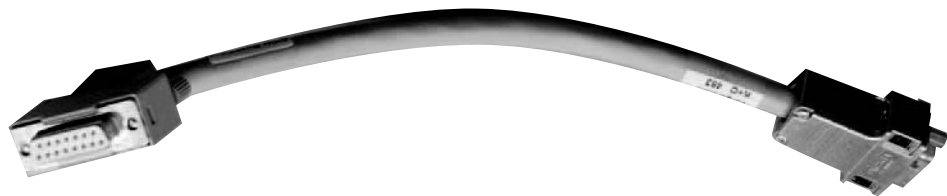

54586AXX

Length of DAE14B: 200 mm ± 20 mm (7.87 in ± 0.79 in)

Cable cross section: 6 x 2 x 0.25 mm² (AWG 23)

| Terminal of 15-pin sub D socket (MOVIDRIVE® MDX61B, option DEH11B//DER11B, X14) | Core color in prefabricated cable | Terminal of the 9-pin sub D connector (encoder end) |
|---|-----------------------------------|---|
| 1 | Yellow (YE) | 1 |
| 2 | Red (RD) | 2 |
| 3 | Pink (PK) | 3 |
| 7 | Violet (VT) | 4 |
| 8 | Brown (BN) | 5 |
| 9 | Green (GN) | 6 |
| 10 | Blue (BU) | 7 |
| 11 | Gray (GY) | 8 |
| 15 | White (WH) | 9 |

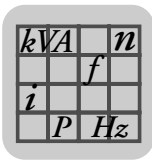

2.17 Interface adapter option type DWE11B/12B

Part number and description

- DWE11B, part number 188 187 6

The interface adapter DWE11B (HTL→TTL) in the form of an adapter cable is used **to connect single-ended HTL encoders to the DEH11B/DEH21B option**. Only the A, B and C tracks are connected. The interface adapter is suitable for all HTL encoders that were operated on MOVIDRIVE® A, MDV and MCV and can be connected without any rewiring effort.

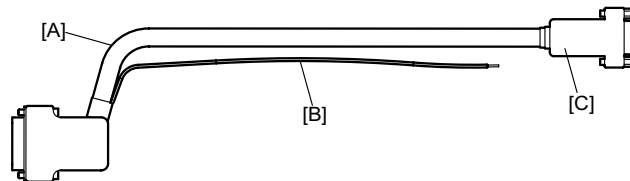

58748AXX

[A] 5 x 2 x 0.25 mm² (AWG 23) / length 1000 mm (39.37 in) /

Max. line length inverter - encoder: 100 m (328 ft)

[B] DC 24 V connection for HTL encoder; 1 x 0.5 mm² (AWG 20) / length 250 mm (9.84 in)

| Signal | Terminal of 9-pin sub D socket [C] (encoder end) |
|--------|--|
| A | 1 |
| B | 2 |
| C | 3 |
| UB | 9 |
| GND | 5 |

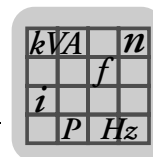

- DWE12B, part number 188 180 9

The interface adapter DWE12B (HTL→TTL) in the form of an adapter cable is used **to connect single-ended HTL encoders to the DEH11B/DEH21B option**. In addition to the A, B and C track, you will also have to connect the negated tracks (A, B, C). SEW-EURODRIVE recommends using this interface adapter for any new system.

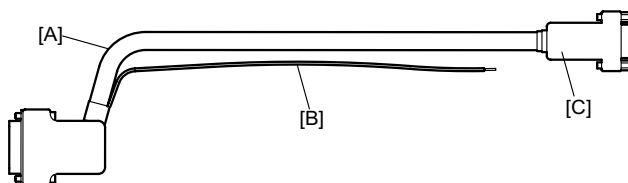

58748XX

[A] 4 x 2 x 0.25 mm² (AWG 23 / length 1000 mm (39.37 in))

Max. line length inverter - encoder: 200 m (656 ft)

[B] DC 24 V connection for HTL encoder; 1 x 0.5 mm² (AWG 20) / length 250 mm (9.84 in)

| Signal | Terminal of 9-pin sub D socket [C] (encoder end) |
|-----------|--|
| A | 1 |
| \bar{A} | 6 |
| B | 2 |
| \bar{B} | 7 |
| C | 3 |
| \bar{C} | 8 |
| UB | 9 |
| GND | 5 |

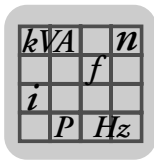

2.18 Interface adapter option type UWS11A

Part number 822 689 X

Description The UWS11A option converts RS232 signals, for example from the PC, into RS485 signals. These RS485 signals can then be routed to the RS485 interface of the MOVIDRIVE® unit (ST11/ST12).

The UWS11A option requires a DC 24 V voltage supply ($I_{\max} = \text{DC } 50 \text{ mA}$).

RS232 interface The connection between UWS11A and PC is made using a commercially available serial interface cable (shielded!).

RS485 interface Max. 32 MOVIDRIVE® units can be networked for communication (max. line length 200 m) via the RS485 interface of the UWS11A. Do not connect external terminating resistors because dynamic terminating resistors are already installed!

Permitted cable cross section: One core per terminal 0.20...2.5 mm² (AWG 24...12)

Two cores per terminal 0.20...1 mm² (AWG 24...17)

Dimension drawing

Dimensions, UWS11A, in mm (in)

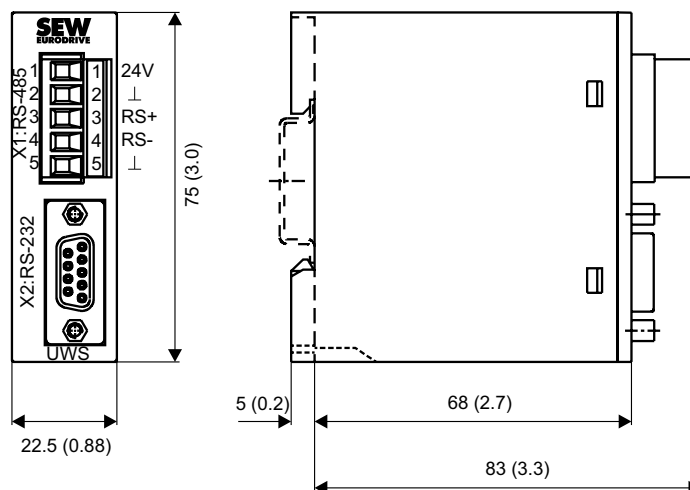

59322BXX

The UWS11A option is mounted on a mounting rail (EN 50022-35 × 7.5) in the control cabinet.

Technical data

| UWS11A | |
|-----------------------------|--|
| Part number | 822 689 X |
| Ambient temperature | 0 ... 40 °C |
| Storage temperature | -25 °C ... +70 °C (according to EN 60721-3-3, class 3K3) |
| Degree of protection | IP20 |
| Current consumption | max. DC 50 mA |
| Weight | 150 g (0.35 lb) |
| Dimensions | 83 mm x 75 mm x 22.5 mm (3.3 in x 3.0 in x 0.866 in) |

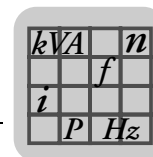

2.19 Interface adapter option type UWS21B

Part number 1820 456 2

Description The UWS21B option converts RS232 signals, for example from the PC, into RS485 signals. These RS485 signals can then be routed to the XT slot of MOVIDRIVE® B.

RS232 interface The connection of UWS21B with PC is made using a standard serial interface cable (shielded).

RS485 interface UWS21B and MOVIDRIVE® B are connected using a serial interface cable with RJ10 connectors.

Scope of delivery The scope of delivery for the UWS21B option includes:

- UWS21B unit
- Serial interface cable with 9-pin sub D socket and 9-pin sub D connector to connect the UWS21B option to the PC.
- Serial interface cable with two RJ10 connectors to connect UWS21B and MOVIDRIVE® B.
- CD-ROM with MOVITOOLS®

Dimension drawing

Dimensions in mm (in)

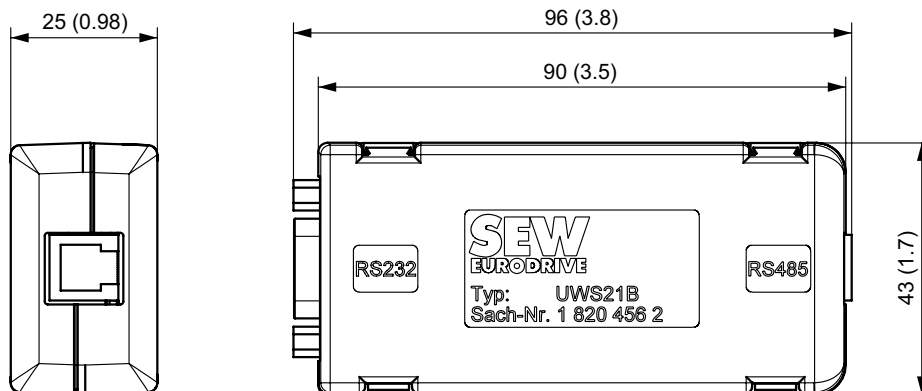

58558BXX

Technical data

| UWS21B | |
|----------------------|--|
| Part number | 1 820 456 2 |
| Ambient temperature | 0 ... 40 °C |
| Storage temperature | -25 °C ... +70 °C (according to EN 60721-3-3, class 3K3) |
| Degree of protection | IP20 |
| Weight | 300 g (0.7 lb) |
| Dimensions | 96 mm x 43 mm x 25 mm (3.8 in x 1.7 in x 0.98 in) |

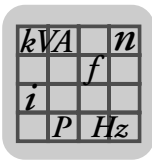

2.20 Interface adapter option type USB11A

Part number 824 831 1

Description Option USB11A enables a PC or laptop with a USB interface to be connected to the XT slot of MOVIDRIVE® B. The USB11A interface adapter supports USB1.1 and USB2.0.

USB11A - PC USB11A is connected to the PC using a commercially available, shielded USB connection cable type USB A-B.

MOVIDRIVE® - USB11A MOVIDRIVE® B and USB11A are connected using a serial interface cable with RJ10 connectors.

Scope of delivery The scope of delivery for the USB11A option includes:

- USB11A interface adapter
- USB connection cable to connect USB11A - PC
- Serial interface cable with two RJ10 connectors to connect USB11A and MOVIDRIVE® B
- CD-ROM with drivers and MOVITOOLS®

Dimension drawing

Dimensions in mm (in)

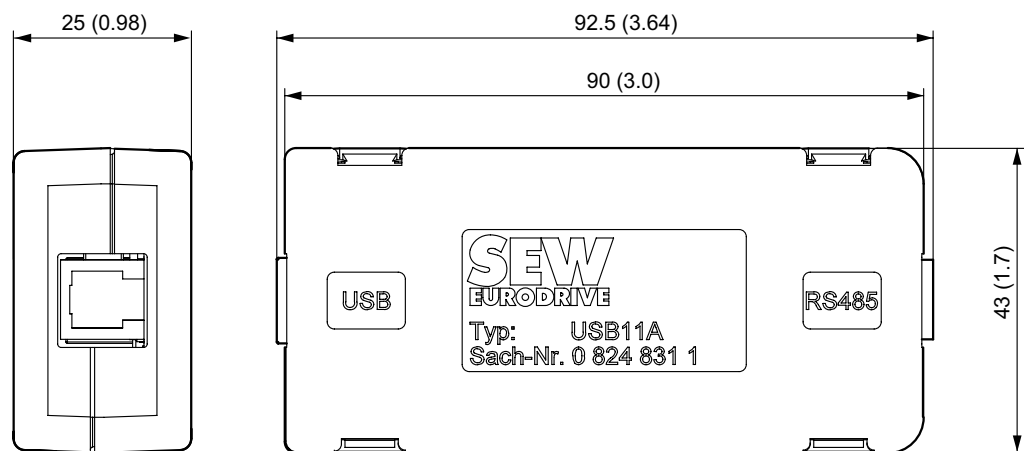

55732CXX

Technical data

| USB11A | |
|-----------------------------|--|
| Part number | 824 831 1 |
| Ambient temperature | 0 ... 40 °C |
| Storage temperature | -25 °C ... +70 °C (according to EN 60721-3-3, class 3K3) |
| Degree of protection | IP20 |
| Weight | 300 g (80.7 lb) |
| Dimensions | 92.5 mm x 43 mm x 25 mm (3.64 in x 1.7 in x 0.98 in) |

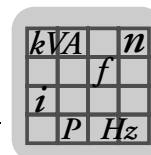

2.21 DC 5 V encoder power supply option type DWI11A

Part number 822 759 4

Description

If you are using an incremental encoder with a DC 5 V encoder power supply, install the DC 5 V encoder power supply option type DWI11A between the inverter and the incremental encoder. This option provides a regulated DC 5 V power supply for the encoder. For this purpose, the DC 12 V power supply for the encoder inputs is converted to DC 5 V by means of a voltage controller. A sensor line is used to measure the supply voltage at the encoder and compensate the voltage drop along the encoder cable.

Incremental encoders with DC 5 V encoder power supply are not allowed to be connected directly to the encoder inputs X14: and X15: . This would cause irreparable damage to the encoder.

| | |
|---|---|
|  | <p>NOTE</p> <p>Note that if a short circuit occurs in the sensor cable, the connected encoder may be exposed to a voltage higher than permitted.</p> |
|---|---|

Recommendation Use prefabricated cables from SEW for the encoder connection.

Dimension drawing

Dimensions in mm (in)

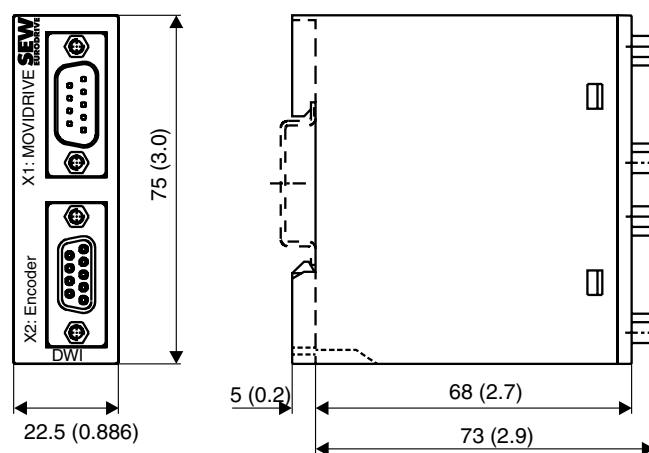

01315DXX

The DWI11A option is mounted on a support rail (EN 50022-35 × 7.5) in the control cabinet.

Technical data

| DC 5 V encoder power supply option type DWI11A | |
|--|--|
| Part number | 822 759 4 |
| Voltage input | DC 10...30 V, $I_{max} = DC 120 \text{ mA}$ |
| Encoder power supply | DC +5 V (up to $U_{max} \approx +10 \text{ V}$), $I_{max} = DC 300 \text{ mA}$ |
| Max. line length that can be connected | 100 m (9,997.44 cm) total Use a shielded twisted-pair cable (A and \bar{A} , B and \bar{B} , C and \bar{C}) for connecting the encoder to the DWI11A and the DWI11A to MOVIDRIVE®. |

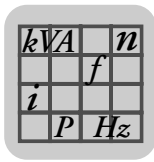

2.22 Input/output card type DIO11B option

Part number 824 308 5

Description

The number of inputs/outputs of the basic MOVIDRIVE® B unit can be expanded with the DIO11B option. The DIO11B option is plugged into the fieldbus slot. If the fieldbus slot is not available, you can plug the DIO11B option into the expansion slot. The programmable signal types of the additional binary inputs/outputs are the same as the basic unit (→ parameter group P6___, Terminal assignment).

Electronics data

| DIO11B option | | |
|------------------------------|---|--|
| | Setpoint input n2 AI21/AI22 operating mode Resolution Internal resistance | X20:1/X20:2 AI21/AI22: Voltage input Differential input or input with AGND reference potential n2 = DC 0...+10 V or DC -10 V...0...+10 V 12 bit, sampling time 1 ms R _i > 40 kΩ |
| | Analog outputs | X21:1/X21:4 X21:2/X21:5 AOV1/AOV2: Voltage outputs DC-10 V...0...+10 V, I _{max} = DC 10 mA, short-circuit proof and protected against external voltage to DC 30 V, selection option → parameter menu P64_ AOC1/AOC2: Current outputs DC 0(4)...20 mA, max. output voltage DC 15 V, short-circuit proof and protected against external voltages up to DC 30 V, selection option → parameter menu P64_ |
| | Response time Resolution | 5 ms 12 bit |
| | Binary inputs X22:1...X22:8 Internal resistance | Isolated (optocoupler), PLC compatible (EN 61131) DI1Ø...DI17 R _i ≈ 3 kΩ, I _E ≈ DC 10 mA Sampling interval 1 ms |
| | Signal level | DC+13 V...+30 V = "1" = Contact closed DC-3 V...+5 V = "0" = Contact open Fulfills EN 61131 |
| | Function | X22:1...X22:8 DI10...DI17: Selection option → Parameter menu P61_ |
| | Binary outputs | X23:1...X23:8 DO1Ø...DO17: PLC-compatible (EN 61131-2), response time 1ms |
| | Signal level | "0" = DC 0 V "1" = DC+24 V |
| | Function | X23:1...X23:8 DO10...DO17: Selection option → Parameter menu P63_ I _{max} = DC 50 mA, short-circuit proof and protected against external voltage to DC 30 V |
| | Reference terminals X20:3/X21:3/X21:6 | X22:9 X22:10 AGND: Reference potential for analog signals (AI21/AI22/AO_1/AO_2) DCOM: Reference potential for binary inputs X22:1...X22:8 (DI1Ø...DI17) DGND: Reference potential for binary signals, reference potential for DC 24 V power supply |
| Voltage input | X23:9 24VIN: Supply voltage DC +24 V for binary outputs DO1Ø...DO17 | |
| Permitted line cross section | One core per terminal: 0.08...1.5 mm ² (AWG 28...16) Two cores per terminal: 0.25...1 mm ² (AWG 22...17) | |

Functions

- 8 binary inputs
- 8 binary outputs
- 1 analog differential input (DC 0...10 V, DC -10 V...+10 V, DC 0...20 mA with corresponding load)
- 2 analog outputs (DC-10 V ... +10 V, DC 0...20 mA, DC 4...20 mA)

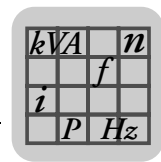

2.23 PROFIBUS fieldbus interface option type DFP21B

Part number 824 240 2

Description

MOVIDRIVE® B can be equipped with a 12 Mbaud fieldbus interface for the PROFIBUS-DP serial bus system. The device master data (GSD) and type files for MOVIDRIVE® are available from the SEW homepage (<http://www.sew-eurodrive.de>) under "Software" to help with project planning and facilitate startup.

PROFIBUS-DP (Decentralized Periphery) is primarily used at the sensor/actuator level where fast response times are required. The principal task of PROFIBUS-DP is rapid cyclic data exchange; e.g. setpoints or binary commands, between central automation units (PROFIBUS master) and decentralized peripheral units (e.g. drive inverters). The DFP21B option supports PROFIBUS-DP and DP-V1. Consequently, MOVIDRIVE® B can be controlled via PLC and PROFIBUS-DP / DP-V1.

Electronics data

| DFP21B option | | |
|---------------|-----------------------------|--|
| | Protocol option | PROFIBUS-DP and DPV1 to IEC 61158 |
| | Baud rate | Automatic detection of baud rate from 9.6 kbaud to 12 Mbaud |
| | Connection technology | 9-pin sub D socket, pin assignment to IEC 61158 |
| | Bus terminator | Not integrated, implement using suitable PROFIBUS connector with terminating resistors that can be activated |
| | Station address | 1 ... 125, adjustable via DIP switches |
| | GSD file name | DP: SEW_6003.GSD DP-V1: SEWA6003.GSD |
| | DP ID number | 6003 _{hex} (24579 _{dec}) |
| | Max. number of process data | 10 process data |

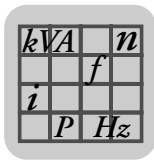

2.24 INTERBUS fieldbus interface option type DFI11B

Part number 824 309 3

Description MOVIDRIVE® B can be equipped with a fieldbus interface for the non-proprietary and standardized INTERBUS sensor/actuator bus system.

INTERBUS is defined in EN 50254 / DIN 19258 and, as far as its function is concerned, it consists of a process data channel and a parameter data channel. Intelligent actuators such as the MOVIDRIVE® B inverter can be controlled and configured in a user-friendly way.

Electronics data

| DFI11B option | | |
|--|-----------------------------|---|
| <p>DFI 11B</p> <p>0 1</p> <p>2⁰ 2¹ 2²</p> <p>1 2 2M 0,5M</p> <p>U_L</p> <p>RC</p> <p>BA</p> <p>RD</p> <p>TR</p> <p>X30</p> <p>X31</p> <p>11874AXX</p> | Supported baud rates | 500 kBaud and 2 MBaud, can be selected via DIP switch |
| | Connection technology | Remote bus input: 9-pin D-sub connector Remote bus output: 9-pin D-sub socket RS485 transmission technology, 6-core shielded and twisted-pair cable |
| | DP identity numbers | $E3_{\text{hex}} = 227_{\text{dec}}$ (1 PCP word) $E0_{\text{hex}} = 224_{\text{dec}}$ (2 PCP words) $E1_{\text{hex}} = 225_{\text{dec}}$ (4 PCP words) $38_{\text{hex}} = 56_{\text{dec}}$ (microprocessor not ready) $03_{\text{hex}} = 3_{\text{dec}}$ (no PCP word) |
| | Max. number of process data | 6 process data |

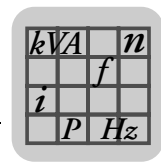

2.25 INTERBUS-LWL fieldbus interface option type DFI21B (FO)

Part number 824 311 5

Description

MOVIDRIVE® B can be equipped with a fieldbus interface for the non-proprietary and standardized INTERBUS sensor/actuator bus system INTERBUS with fiber optic cables (INTERBUS-LWL).

INTERBUS is defined in EN 50254 / DIN 19258 and, as far as its function is concerned, it consists of a process data channel and a parameter data channel. Intelligent actuators such as the MOVIDRIVE® B inverter can be controlled and configured in a user-friendly way.

Electronics data

| DFI21B option | | |
|-----------------|-----------------------------|---|
| <p>11875AXX</p> | Supported baud rates | 500 kBaud and 2 MBaud, can be selected via DIP switch |
| | Connection technology | F-SMA connector |
| | DP identity numbers | E3 _{hex} = 227 _{dec} (1 PCP word) E0 _{hex} = 224 _{dec} (2 PCP words) E1 _{hex} = 225 _{dec} (4 PCP words) 38 _{hex} = 56 _{dec} (microprocessor not ready) 03 _{hex} = 3 _{dec} (no PCP word) |
| | Max. number of process data | 6 process data |

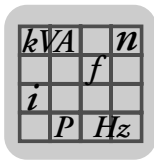

2.26 DFE11B fieldbus interface option Modbus/TCP

Part number 1820 036 2

Description

The MOVIDRIVE® MDX61B inverter enables you to use the DFE11B option to connect to higher-level automation, project planning and visualization systems via Ethernet (MODBUS/TCP protocol) thanks to its powerful, universal fieldbus interface. You can use option DFE11B to communicate directly with the inverters via Ethernet and operate the MOVITOOLS® software to change parameters and IPOS^{plus}® programs. An integrated Web server makes it possible for the user to access diagnostic values quickly and easily using a standard browser (e.g. Internet Explorer).

Electronics data

| Option DFE11B | | |
|---------------|--|--|
| | <p>Application protocols</p> <ul style="list-style-type: none"> • MODBUS/TCP (Transmission Control Protocol) to control and set parameters for the inverter. • HTTP (Hypertext Transfer Protocol) for diagnostics using a Web browser. • SMLP (Simple Movilink Protocol), protocol used by MOVITOOLS®. • DHCP (Dynamic Host Configuration Protocol) to assign address parameter automatically. | |
| | <p>Port numbers used</p> <ul style="list-style-type: none"> • 502 (MODBUS) • 300 (SMLP) • 80 (HTTP) • 67 / 68 (DHCP) | |
| | <p>Ethernet services</p> <ul style="list-style-type: none"> • ARP • ICMP (Ping) | |
| | <p>Automatic baud rate detection</p> <p>10 MBaud / 100 MBaud</p> | |
| | <p>Max. number of process data</p> <p>10 process data</p> | |
| | <p>Connection technology</p> <p>RJ45 plug connector</p> | |
| | <p>Addressing</p> <p>4 byte IP address</p> | |
| | <p>Tools for startup</p> <ul style="list-style-type: none"> • MOVITOOLS® MotionStudio software • DBG60B keypad | |
| | | |
| | | |

Functions

- MODBUS/TCP protocol
- RJ45 plug connector, star-type cabling
- Up to 10 process data and parameter data items can be transferred at the same time
- Three ways to allocate the IP address:
 1. Set the node address manually (byte 0 or IP address)
 2. Make the setting using the DBG60B keypad and MOVITOOLS®
 3. Use the DHCP server
- Engineering access using MOVITOOLS® via Ethernet-TCP/IP
- Inverter diagnostics using a standard browser (e.g. Internet Explorer) via the integrated Web server:
 - Transfer display values
 - Configure DFE11B (after login)

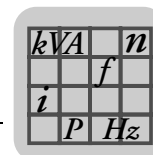

2.27 PROFINET IO RT type DFE12B fieldbus interface option

Part number 1820 563 1

2

Description The MOVIDRIVE® MDX61B inverter enables you to use the DFE12B option to connect to higher-level automation, project planning and visualization systems via Ethernet (PROFINET/IO protocol) thanks to its powerful, universal fieldbus interface. You can use option DFE12B to communicate directly with the inverters via Ethernet and operate the MOVITOOLS® software to change parameters and IPOS^{plus}® programs. An integrated Web server makes it possible for the user to access diagnostic values quickly and easily using a standard browser (e.g. Internet Explorer).

Electronics data

| Option DFE12B | | |
|---------------|-----------------------------|---|
| | Application protocols | <ul style="list-style-type: none"> • PROFINET IO to control and configure the drive inverter. • HTTP (Hypertext Transfer Protocol) for diagnostics using a Web browser. • SMLP (Simple Movilink Protocol), protocol used by MOVITOOLS®. |
| | Port numbers used | <ul style="list-style-type: none"> • 34962 - 34964 (PROFINET IO) • 300 (SMLP) • 80 (HTTP) |
| | Ethernet services | <ul style="list-style-type: none"> • ICMP (ping) • ARP |
| | Transmission rate | 100 MBit full duplex |
| | Transmission process | 100BASETX |
| | Max. number of process data | 10 process data |
| | Connection technology | RJ45 plug connector |
| | Auto-negation | Yes |
| | GSD file | GSDML-V1.0-SEW-DFE12B-xxxxxxx.xml (xxxxxxx is a placeholder for year/month/day) |
| | SEW manufacturer ID | 010A _{hex} |
| | Device ID | 0001 _{hex} |
| | Alarms | Diagnostic alarm in the event of a unit fault (can be activated) |
| | Diagnostics | Yes |
| | Configuration via PROFINET | In preparation |
| | Max. number of connections | 3 |
| | Tools for startup | <ul style="list-style-type: none"> • MOVITOOLS® MotionStudio software • DBG60B keypad |

Functions

- PROFINET IO protocol
- RJ45 plug connector, star-type cabling
- Up to 10 process data and PROFINET diagnostic parameter data items can be transferred at the same time
- The PROFINET IO controller assigns the IP address
- Engineering access using MOVITOOLS® via Ethernet-TCP/IP
- Inverter diagnostics using a standard browser (e.g. Internet Explorer) via the integrated Web server:
 - Transfer display values
 - DFE11B configuration (after login)

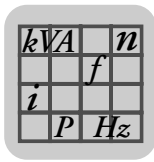

2.28 PROFINET IO RT type DFE32B fieldbus interface option

Part number 1821 345 6

Description

The MOVIDRIVE[®] MDX61B inverter enables you to use the DFE32B option to connect to higher-level automation, project planning and visualization systems via Ethernet (PROFINET/IO protocol) thanks to its powerful, universal fieldbus interface. You can use option DFE32B to communicate directly with the inverters via Ethernet and operate the MOVITOOLS[®] software to change parameters and IPOS^{plus}[®] programs. An integrated Web server makes it possible for the user to access diagnostic values quickly and easily using a standard browser (e.g. Internet Explorer).

Electronics data

| DFE32B option | | |
|---------------|--|--|
| | Application protocol | <ul style="list-style-type: none"> • PROFINET IO (Ethernet frames with frame identification 8892_{hex}) to control and set parameters for the inverter. • HTTP (Hypertext Transfer Protocol) for diagnostics using a Web browser. • SMLP (Simple Movilink Protocol), protocol used by MOVITOOLS[®]. |
| | Port numbers used | <ul style="list-style-type: none"> • 300 (SMLP) • 80 (HTTP) |
| | Ethernet services | <ul style="list-style-type: none"> • ARP • ICMP (Ping) |
| | ISO / OSI layer 2 | Ethernet II |
| | Baud rate | 100 Mbaud in full duplex process |
| | Connection technology | Two RJ45 plug connectors with integrated switch and auto-crossing |
| | Addressing | 4 byte IP address or MAC-ID (00:0F:69:xx:xx:xx) |
| | Manufacturer ID (vendor ID) | 010A _{hex} |
| | Tools for startup | <ul style="list-style-type: none"> • MOVITOOLS[®] MotionStudio version 5.40 and higher. • DBG60B keypad |
| | Firmware status of MOVIDRIVE [®] MDX61B | Firmware version 824 854 0.17 or higher (→ display with P076) |

Functions

- PROFINET IO protocol
- Two RJ45 plug connectors for star or line type cabling
- Up to 10 process data and PROFINET diagnostic parameter data items can be transferred at the same time
- The PROFINET IO controller assigns the IP address
- Engineering access using MOVITOOLS[®] via Ethernet-TCP/IP
- Inverter diagnostics using a standard browser (e.g. Internet Explorer) via the integrated Web server:
 - Transfer display values
 - DFE32B configuration (after login)

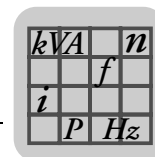

2.29 DFE13B EtherNet/IP fieldbus interface option

Part number 1820 565 8

Description

The MOVIDRIVE® MDX61B inverter enables you to use the DFE13B option to connect to higher-level automation, project planning and visualization systems via Ethernet (EtherNet/IP protocol) thanks to its powerful, universal fieldbus interface. You can use option DFE13B to communicate directly with the inverters via Ethernet and operate the MOVITOOLS® software to change parameters and IPOS^{plus}® programs. An integrated Web server makes it possible for the user to access diagnostic values quickly and easily using a standard browser (e.g. Internet Explorer).

Electronics data

| Option DFE13B | | |
|---------------|-------------------------------|--|
| | Application protocols | <ul style="list-style-type: none"> • EtherNet/IP (Industrial Protocol) to control and set parameters for the drive inverter. • HTTP (Hypertext Transfer Protocol) for diagnostics using a Web browser. • SMLP (Simple Movilink Protocol), protocol used by MOVITOOLS®. • DHCP (Dynamic Host Configuration Protocol) to assign address parameter automatically. |
| | Port numbers used | <ul style="list-style-type: none"> • 44818 (Ethernet/IP TCP) • 2222 (Ethernet/IP UDP) • 300 (SMLP) • 80 (HTTP) • 67 / 68 (DHCP) |
| | Ethernet services | <ul style="list-style-type: none"> • ARP • ICMP (Ping) |
| | Automatic baud rate detection | 10 MBaud / 100 MBaud |
| | Max. number of process data | 10 process data |
| | Connection technology | RJ45 plug connector |
| | Addressing | 4 byte IP address |
| | Manufacturer ID | 013B _{hex} |
| | Tools for startup | <ul style="list-style-type: none"> • MOVITOOLS® MotionStudio software • DBG60B keypad |

Functions

- EtherNet/IP protocol
- RJ45 plug connector, star-type cabling
- Up to 10 process data and parameter data items can be transferred at the same time
- Two ways to allocate the IP address:
 1. Make the setting using the DBG60B keypad and MOVITOOLS®
 2. Use the DHCP server
- Engineering access using MOVITOOLS® via Ethernet-TCP/IP
- Inverter diagnostics using a standard browser (e.g. Internet Explorer) via the integrated Web server:
 - Transfer display values
 - DFE13B configuration (after login)

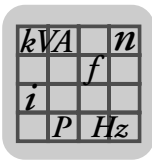

2.30 DFE33B EtherNet/IP fieldbus interface option

Part number 1821 346 4

Description

The MOVIDRIVE® MDX61B inverter enables you to use the DFE33B option to connect to higher-level automation, project planning and visualization systems via Ethernet (EtherNet/IP protocol) thanks to its powerful, universal fieldbus interface. You can use option DFE33B to communicate directly with the inverters via Ethernet and operate the MOVITOOLS® software to change parameters and IPOS^{plus}® programs. An integrated Web server makes it possible for the user to access diagnostic values quickly and easily using a standard browser (e.g. Internet Explorer).

Electronics data

| DFE33B option | | |
|---------------|--------------------------------------|--|
| | Application protocol | <ul style="list-style-type: none"> • EtherNet/IP (Industrial Protocol) to control and set parameters for the drive inverter. • HTTP (Hypertext Transfer Protocol) for diagnostics using a Web browser. • SMLP (Simple Movilink Protocol), protocol used by MOVITOOLS®. • DHCP (Dynamic Host Configuration Protocol) to assign address parameter automatically. |
| | Port numbers used | <ul style="list-style-type: none"> • 44818 (EtherNet/IP TCP) • 2222 (EtherNet/IP UDP) • 300 (SMLP) • 80 (HTTP) • 67 / 68 (DHCP) |
| | Ethernet services | <ul style="list-style-type: none"> • ARP • ICMP (Ping) |
| | ISO / OSI layer 2 | Ethernet II |
| | Automatic baud rate detection | 10 MBaud / 100 MBaud |
| | Connection technology | Two RJ45 plug connectors with integrated switch and auto-crossing |
| | Addressing | 4 byte IP address or MAC-ID (00-0F-69-xx-xx-xx) |
| | Manufacturer ID (vendor ID) | 013B _{hex} |
| | Tools for startup | <ul style="list-style-type: none"> • MOVITOOLS® MotionStudio version 5.40 and higher. • DBG60B keypad |
| | Firmware status of MOVIDRIVE® MDX61B | Firmware version 824 854 0.17 or higher (→ display with P076) |

Functions

- EtherNet/IP protocol
- Two RJ45 plug connectors for star or line type cabling
- Up to 10 process data and parameter data items can be transferred at the same time
- Two ways to allocate the IP address:
 1. Make the setting using the DBG60B keypad and MOVITOOLS®
 2. Use the DHCP server
- Engineering access using MOVITOOLS® via Ethernet TCP/IP
- Inverter diagnostics using a standard browser (e.g. Internet Explorer) via the integrated Web server:
 - Transfer display values
 - DFE33B configuration (after login)

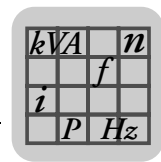

2.31 EtherCAT fieldbus interface option type DFE24B

Part number 1821 126 7

Description

The MOVIDRIVE® MDX61B inverter enables you to use the DFE24B option to connect to higher-level automation, project planning and visualization systems via EtherCAT thanks to its powerful, universal fieldbus interface. You can use option DFE24B to communicate directly with the inverters via EtherCAT and operate the MOVITOOLS® software to change parameters and IPOS^{plus}® programs.

Electronics data

| DFE24B option | | |
|---------------|------------------------------|---|
| | Standards | IEC 61158, IEC 61784-2 |
| | Baud rate | 100 Mbaud full duplex |
| | Connection technology | Two RJ45 plug connectors |
| | Bus terminator | Not integrated as bus termination is activated automatically. |
| | OSI layer | Ethernet II |
| | Station address | Setting via EtherCAT master (→ Display with P093) |
| | XML file name | SEW_DFE24B.xml |
| | Vendor ID | 0x59 (CANopenVendor ID) |
| | EtherCAT services | <ul style="list-style-type: none"> • CoE (CANopen over EtherCAT) • VoE (Simple MOVILINK protocol over EtherCAT) |
| | MOVIDRIVE® B firmware status | 824 854 0.18 or higher (→ isplay with P076) |
| | Tools for startup | <ul style="list-style-type: none"> • MOVITOOLS® MotionStudio version 5.40 and higher. • DBG60B keypad |

Functions

- EtherCAT
- Two RJ45 plug connectors for line type cabling
- Simultaneous communication of up to 10 process data and parameter data as well as access (Rx, Tx) to 8 IPOS^{plus}® variables
- Automatic addressing via EtherCAT master
- Engineering access using MOVITOOLS® MotionStudio via EtherCAT

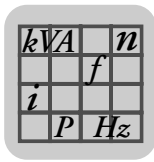

2.32 DeviceNet fieldbus interface option type DFD11B

Part number 824 972 5

Description

The MOVIDRIVE® MDX61B inverter in conjunction with the DFD11B option allows connection to higher-level automation, project planning and visualization systems via the open and standardized DeviceNet fieldbus system thanks to the option's high-performance universal fieldbus interface.

The DeviceNet fieldbus interface type DFD11B can be plugged into the fieldbus slot on all MOVIDRIVE® MDX61B units. The DFD11B option enables communication with the machine control for a maximum of 10 process data. You need an EDS file to be able to integrate the DFD11B in the machine control. You can download this file from the SEW homepage in the Software section.

Electronics data

| DFD11B option | | |
|---------------|--|---|
| | <p>Communication protocol</p> <p>Number of process data words</p> <p>Baud rate</p> <p>Bus cable length</p> <p>Transmission level</p> <p>Connection technology</p> <p>MAC ID</p> <p>Supported services</p> <p>Tools for startup</p> | <p>Master/slave connection set according to DeviceNet specification version 2.0</p> <p>Can be set using DIP switch:</p> <ul style="list-style-type: none"> • 1 ... 10 process data words • 1 ... 4 process data words with bit-strobe I/O <p>125, 250 or 500 kbaud, can be set using DIP switch</p> <p>For thick cable according to DeviceNet specification 2.0 appendix B:</p> <ul style="list-style-type: none"> • 500 m at 125 kBaud • 250 m at 250 kBaud • 100 m at 500 kBaud <p>ISO 11 98 - 24 V</p> <ul style="list-style-type: none"> • 2-wire bus and 2-wire supply voltage DC 24 V with 5-pole Phoenix terminal • Pin assignment according to DeviceNet specification <p>0 ... 63, can be set using DIP switch Max. 64 stations</p> <ul style="list-style-type: none"> • Polled I/O: 1 ... 10 words • Bit-strobe I/O: 1 ... 4 words • Explicit messages: <ul style="list-style-type: none"> – Get_Attribute_Single – Set_Attribute_Single – Reset – Allocate_MS_Connection_Set – Release_MS_Connection_Set <ul style="list-style-type: none"> • MOVITOOLS® MotionStudio software • DBG60B keypad |

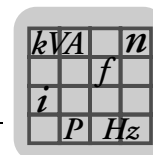

2.33 CANopen fieldbus interface option type DFC11B

Part number 824 317 4

Description

The MOVIDRIVE® MDX61B inverter in conjunction with the DFC11B option allows connection to higher-level automation, project planning and visualization systems via the open and standardized CANopen fieldbus system thanks to the option's high-performance universal fieldbus interface. You can also access parameters and process data using the MOVILINK® protocol designed especially for units from SEW-EURODRIVE.

The DFC11B fieldbus interface type can be plugged into the fieldbus slot on all MOVIDRIVE® MDX61B units. In this way, a second system bus (CAN) on MOVIDRIVE® is made available. The DFC11B option enables communication with the machine control for a maximum of 10 process data. You need an EDS file to be able to integrate the DFC11B in the higher-level CANopen control. You can download this file from the SEW homepage in the Software section.

Electronics data

| DFC11B option | |
|-----------------|--|
| <p>11883AXX</p> | <p>Communication profile</p> <ul style="list-style-type: none"> • SEW-MOVILINK® • CANopen • CAN Layer 2 |
| | <p>Number of process data words</p> <p>1 ... 10 process data words</p> |
| | <p>Baud rate</p> <p>Setting using parameter P894: 125 kBaud / 250 kBaud / 500 kBaud / 1 MBaud</p> |
| | <p>Connection technology</p> <p>9-pole Sub-D plug connector X30 (plug assigned to CIA standard) or terminal X31</p> |
| | <p>Permitted line cross section X31 (CAN-Bus connection)</p> <p>One core per terminal: 0.20 ... 2.5 mm² (AWG24 ... 12) Two cores per terminal: 0.25 ... 1 mm² (AWG22 ... 17)</p> |
| | <p>Terminating resistor</p> <p>120 Ω (set using DIP switch S1-R)</p> |
| | <p>Addressing</p> <p>Setting via parameter P891 (SBus MOVILINK) or P896 (CANopen)</p> |
| | <p>Tools for startup</p> <ul style="list-style-type: none"> • MOVITOOLS® MotioStudio software • DBG60B keypad |

Functions

- CAN Layer 2 and communication profile MOVILINK® or CANopen
- Electrical isolation via optocoupler

| | |
|--|---|
| | <p>NOTE</p> |
| | <p>If electrical isolation is not required, the CAN-Bus can be connected directly to the basic unit at X12:SC11/SC12 without the DFC11B option. This does not effect the functionality.</p> |

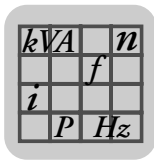

2.34 Synchronous operation board option type DRS11B

Part number 824 672 6

Description The DRS11B option enables a group of motors to run in angular synchronous operation or in an adjustable proportional relationship. For detailed information, refer to the "Synchronous Operation Board Type DRS11B" manual, which can be ordered from SEW-EURODRIVE. The basis for synchronous operation is the continuous comparison of the rotor angle positions of the master and slave motors. The motors must be equipped with encoders. The DRS11B option is plugged into the expansion slot.

| Option DRS11B | | | |
|---|--|---|--|
| <p>11885AXX</p> | Binary inputs | X40:1...X40:6 | EINGØ...EING5: isolated (opto-coupler) PLC compatible (EN 61131) $R_i \approx 3 \text{ k}\Omega$, $I_E \approx \text{DC } 10 \text{ mA}$ Sampling interval 5 ms |
| | Internal resistance | | |
| | Signal level | | DC+13 V...+30 V = "1" = Contact closed DC-3 V...+5 V = "0" = Contact open |
| | Function | | Fixed assignment with: <ul style="list-style-type: none"> EINGØ = Free-running INP1 = Offset 1 INP2 = Offset 2 INP3 = Offset 3 INP4 = IPOS^{plus}® variable H477.0 INP5 = IPOS^{plus}® variable H477.1 |
| | Binary outputs | X40:9/X40:10 | OUTPØ/OUTP1: PLC compatible (EN 61131-2) Response time 5 ms |
| | Signal level | | "0" = DC 0 V "1" = DC+24 V Caution: Do not apply external voltage! |
| | Function | | Fixed assignment with: <ul style="list-style-type: none"> OUTPØ = IPOS^{plus}® variable H476.0 OUTP1 = IPOS^{plus}® variable H476.1 $I_{\text{max}} = \text{DC } 50 \text{ mA}$, short-circuit proof, protected against external voltage to DC 30 V |
| | Reference terminals | X40:11 X40:7 | DGND: Reference potential for binary signals DCOM: Reference potential for binary inputs X40:1...X40:6 (INPØ...INP5) VO24: Voltage output DC +24 V, max. DC 100 mA |
| | Voltage output | X40:8 | |
| | Synchronous encoder input X41: Encoder power supply | | Max. 200 kHz, signal level according to RS422 or sin/cos DC +24 V, $I_{\text{max}} = 650 \text{ mA}^1$ 9-pin D-sub socket |
| Master encoder input X42: Encoder power supply | | Max. 200 kHz, signal level according to RS422 or sin/cos DC+24 V, $I_{\text{max}} = \text{DC } 650 \text{ mA}^1$ 9-pin D-sub socket | |
| Encoder simulation output X43: | | Signal level to RS422 9-pin D-sub connector | |
| Voltage input | X44:1 X44:2 X44:3 | GND DC+24 V supply voltage for binary outputs X40:9/X40:10 and encoder GND | |
| Permitted line cross section | | One core per terminal: $0.08 \dots 1.5 \text{ mm}^2$ (AWG28 ... 16) Two cores per terminal: $0.25 \dots 1 \text{ mm}^2$ (AWG22 .. 17) | |

1) Total current load (X41 and X42) of the DC 24 V encoder supply \leq DC 650 mA

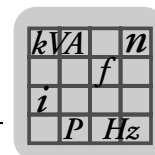

2.35 PROFIBUS DP-V1 with PROFIsafe fieldbus interface option type DFS11B

Part number 1820 962 9

Description

MOVIDRIVE® B can be equipped with a 12 Mbaud fieldbus interface DFS11B for the PROFIBUS-DP-V1 serial bus system with PROFIsafe. In addition to cyclical and acyclical data exchange, safety-oriented communication takes place that allows to switch a safe F-DO output. The device master data (GSD) and type files for MOVIDRIVE® are available from the SEW homepage (<http://www.sew-eurodrive.de>) under "Software" to help with project planning and facilitate startup.

For more detailed information, refer to the "Fieldbus Interface DFS11B PROFIBUS DP-V1 with PROFIsafe" manual. You can order this manual from SEW-EURODRIVE.

Electronics data

| DFS11B option | | |
|---------------------|-------------------------------|--|
| | PROFIBUS protocol options | PROFIBUS DP and DP-V1 according to IEC 61158 |
| | Automatic baud rate detection | 9.6 kBaud ... 12 MBaud |
| | Connection technology | <ul style="list-style-type: none"> 9-pin D-sub socket Pin assignment acc. to IEC 61158 |
| | Bus terminator | Not integrated, implement using suitable PROFIBUS plug with terminating resistors that can be switched on. |
| | Station address | 1 ... 125, adjustable via DIP switches |
| | GSD file name | SEW_600C.GSD |
| | DP ID number | 600C = 24588 _{hex} |
| | Diagnostics data | <ul style="list-style-type: none"> Max. 8 bytes Standard diagnostics: 6 bytes |
| | Tools for startup | <ul style="list-style-type: none"> MOVITOOLS® MotionStudio software DBG60B keypad |
| | F address | 1 ... 1022 DIP switch for setting the failsafe address |
| Ambient temperature | 0 to 55 °C | |

11892AXX

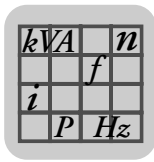
Safety part

| Safety characteristics | |
|---|--|
| Highest possible safety category | <ul style="list-style-type: none"> SIL 3 according to EN 61508 Category 4 according to EN 954-1 Performance level e according to EN ISO 13849-1 |
| System structure | 2 channels with diagnostics (1002D) |
| Type of operating mode | "High demand" rate according to EN 61508 |
| Probability of dangerous failure per hour (PFH value) | <1.00E-09 (1 FIT) |
| Proof test interval (EN61508) | 10 years, after which the component must be replaced with a new one |
| Repair time | 100 hours |
| Safe status | Value "0" for all safety-oriented F-DO process values (output disabled) |
| Safe output | |
| P-M switch (from load voltage supply) | DC 24 V output according to EN 61131-2, protected against short circuits and overloads |
| Rated current | 1A |
| Leakage current (at "0" signal) | Typically –2 mA (with 2 V / 1 kΩ load resistance) (Note: Current flows from F-DO_M to F-DO_P) |
| Internal voltage drop (P and M output) | max. 3 V |
| Short circuit protection | Electronic, response value: 2.8 A ... 9 A |
| Overload protection | Response value: 1.4 A ... 1.6 A |
| Load resistance range | 24 kΩ ... 1 kΩ |
| Voltage limitation when switching off inductive loads | Typically –70 V |
| Response time (command via PROFIsafe → output switches) | ≤ 25 ms |
| Maximum line length | 30 m |

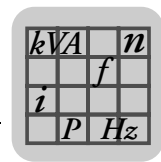

2.36 PROFIBUS DP-V1 with PROFIsafe fieldbus interface option type DFS12B

Part number 1820 963 7 (in preparation)

Description

MOVIDRIVE® B can be equipped with a 12 Mbaud fieldbus interface DFS12B for the PROFIBUS-DP-V1 serial bus system with PROFIsafe. In addition to cyclical and acyclical data exchange, safety-oriented communication takes place in conjunction with the DCS21B option. The device master data (GSD) and type files for MOVIDRIVE® are available from the SEW homepage (<http://www.sew-eurodrive.de>) under "Software" to help with project planning and facilitate startup.

For more detailed information, refer to the "Fieldbus Interface DFS12B PROFIBUS DP-V1 with PROFIsafe" manual. You can order this manual from SEW-EURODRIVE.

Electronics data

| DFS12B option | | |
|-----------------|-------------------------------|--|
| <p>11893AXX</p> | PROFIBUS protocol options | PROFIBUS DP and DP-V1 according to IEC 61158 |
| | Automatic baud rate detection | 9.6 kBaud ... 12 MBaud |
| | Connection technology | <ul style="list-style-type: none"> 9-pin D-sub socket Pin assignment acc. to IEC 61158 |
| | Bus terminator | Not integrated, implement using suitable PROFIBUS plug with terminating resistors that can be switched on. |
| | Station address | 1 ... 125, adjustable via DIP switches |
| | GSD file name | SEW_600C.GSD |
| | DP ID number | 600C = 24588 _{hex} |
| | Diagnostics data | <ul style="list-style-type: none"> Max. 8 bytes Standard diagnostics: 6 bytes |
| | Tools for startup | <ul style="list-style-type: none"> MOVITOOLS® MotionStudio software DBG60B keypad |
| | F address | The failsafe address is set using the DCS21B option |
| | Ambient temperature | 0 to 55 °C |

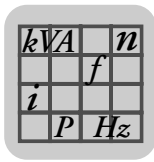

2.37 PROFINET IO with PROFIsafe fieldbus interface option, type DFS21B

Part number 1821 183 6

Description

The MOVIDRIVE® MDX61B inverter enables you to use the DFS21B option to connect to higher-level automation, project planning and visualization systems via Ethernet (PROFINET/IO RT protocol) thanks to its powerful, universal fieldbus interface. In addition to cyclical and acyclical data exchange, safety-oriented communication takes place that allows to switch a safe F-DO output. You can use option DFS21B to communicate directly with the inverters via Ethernet and operate the MOVITOOLS® software to change parameters and IPOS^{plus}® programs. An integrated Web server makes it possible for the user to access diagnostic values quickly and easily using a standard browser (e.g. Internet Explorer).

For more detailed information, refer to the "Fieldbus Interface DFS21B PROFINET IO with PROFIsafe" manual. You can order this manual from SEW-EURODRIVE.

Electronics data

| DFS21B option | |
|-----------------|---|
| <p>11894AXX</p> | <p>Application protocol</p> <ul style="list-style-type: none"> • PROFINET IO (Ethernet frames with frame identification 8892_{hex}) to control and set parameters for the inverter. • HTTP (Hypertext Transfer Protocol) for diagnostics using a Web browser. • SMLP (Simple Movilink Protocol), protocol used by MOVITOOLS®. |
| | <p>Port numbers used</p> <ul style="list-style-type: none"> • 300 (SMLP) • 80 (HTTP) |
| | <p>Ethernet services</p> <ul style="list-style-type: none"> • ARP • ICMP (Ping) |
| | <p>ISO / OSI layer 2</p> <p>Ethernet II</p> |
| | <p>Baud rate</p> <p>100 Mbaud in full duplex process</p> |
| | <p>Connection technology</p> <p>Two RJ45 plug connectors with integrated switch and auto-crossing</p> |
| | <p>Addressing</p> <p>4 byte IP address or MAC-ID (00:0F:69:xx:xx:xx)</p> |
| | <p>Manufacturer ID (vendor ID)</p> <p>010A_{hex}</p> |
| | <p>Tools for startup</p> <ul style="list-style-type: none"> • MOVITOOLS® MotionStudio version 5.40 and higher. • DBG60B keypad |
| | <p>F address</p> <p>1 ... 1022 DIP switch for setting the failsafe address</p> |
| | <p>Firmware status of MOVIDRIVE® MDX61B</p> <p>Firmware version 824 854 0.17 or higher (→ display with P076)</p> |
| | <p>Ambient temperature</p> <p>0 to 55 °C</p> |

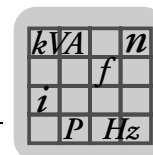

Safety part

| Safety characteristics | |
|--|--|
| Highest possible safety category | <ul style="list-style-type: none"> • SIL 3 according to EN 61508 • Category 4 according to EN 954-1 • Performance level e according to EN ISO 13849-1 |
| System structure | 2 channels with diagnostics (1oo2D) |
| Type of operating mode | "High demand" rate according to EN 61508 |
| Probability of dangerous failure per hour (PFH value) | <1.00E-09 (1 FIT) |
| Proof test interval (EN61508) | 10 years, after which the component must be replaced with a new one |
| Repair time | 100 hours |
| Safe status | Value "0" for all safety-oriented F-DO process values (output disabled) |
| Safe output | |
| P-M switch (from load voltage supply) | DC 24 V output according to EN 61131-2, protected against short circuits and overloads |
| Rated current | 1A |
| Leakage current (at "0" signal) | Typically –2 mA (with 2 V / 1 kΩ load resistance) (Note: Current flows from F-DO_M to F-DO_P) |
| Internal voltage drop (P and M output) | max. 3 V |
| Short circuit protection | Electronic, response value: 2.8 A ... 9 A |
| Overload protection | Response value: 1.4 A ... 1.6 A |
| Load resistance range | 24 kΩ ... 1 kΩ |
| Voltage limitation when switching off inductive loads | Typically –70 V |
| Response time (command via PROFIsafe® → output switches) | ≤ 25 ms |
| Maximum line length | 30 m |

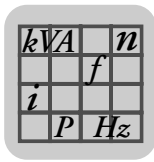

2.38 PROFINET IO with PROFIsafe fieldbus interface option, type DFS22B

Part number 1821 184 4

Description

The MOVIDRIVE® MDX61B inverter enables you to use the DFS22B option to connect to higher-level automation, project planning and visualization systems via Ethernet (PROFINET/IO RT protocol) thanks to its powerful, universal fieldbus interface. In addition to cyclical and acyclical data exchange, safety-oriented communication takes place in conjunction with the DCS21B option. You can use option DFS22B to communicate directly with the inverters via Ethernet and operate the MOVITOOLS® software to change parameters and IPOS^{plus}® programs. An integrated Web server makes it possible for the user to access diagnostic values quickly and easily using a standard browser (e.g. Internet Explorer).

For more detailed information, refer to the "Fieldbus Interface DFS22B PROFINET IO with PROFIsafe" manual. You can order this manual from SEW-EURODRIVE.

Electronics data

| DFS22B option | |
|--|---|
| <p>11895AXX</p> | <p>Application protocol</p> <ul style="list-style-type: none"> • PROFINET IO (Ethernet frames with frame identification 8892_{hex}) to control and set parameters for the inverter. • HTTP (Hypertext Transfer Protocol) for diagnostics using a Web browser. • SMLP (Simple Movilink Protocol), protocol used by MOVITOOLS®. |
| | <p>Port numbers used</p> <ul style="list-style-type: none"> • 300 (SMLP) • 80 (HTTP) |
| | <p>Ethernet services</p> <ul style="list-style-type: none"> • ARP • ICMP (Ping) |
| | <p>ISO / OSI layer 2</p> <p>Ethernet II</p> |
| | <p>Baud rate</p> <p>100 Mbaud in full duplex process</p> |
| | <p>Connection technology</p> <p>Two RJ45 plug connectors with integrated switch and auto-crossing</p> |
| | <p>Addressing</p> <p>4 byte IP address or MAC-ID (00:0F:69:xx:xx:xx)</p> |
| | <p>Manufacturer ID (vendor ID)</p> <p>010A_{hex}</p> |
| | <p>Tools for startup</p> <ul style="list-style-type: none"> • MOVITOOLS® MotionStudio version 5.40 and higher. • DBG60B keypad |
| | <p>F address</p> <p>The failsafe address is set using the DCS21B option</p> |
| <p>Firmware status of MOVIDRIVE® MDX61B</p> <p>Firmware version 824 854 0.17 or higher (→ display with P076)</p> | |
| <p>Ambient temperature</p> <p>0 ... 55 °C</p> | |

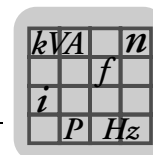

2.39 MOVISAFE® DCS21B/31B safety module option

Part numbers

- DCS21B complete with prefabricated cable DAE34B (CAN bus connection between DCS21B X86 and DFS21B X31): 1821 895 4
- DCS21B without prefabricated cable: 1820 392 2
- DCS31B: 1820 958 0

Description

The DCS21B and DCS31B options of the MOVISAFE® series are designed as expansion options for functional safety. They are capable of performing various drive monitoring functions, such as standstill, speed, direction of rotation or position monitoring. Additionally, sensor signals can be processed via safe inputs and outputs and MOVIDRIVE® B can be switched off according to stop categories 0, 1, or 2.

To being able to communicate with a higher-level safety controller in a safety-oriented manner, the DCS21B option must be used together with the DFS12B fieldbus interface (PROFIBUS DP-V1) or DFS22B (PROFINET IO). The DCS21B/31B option is plugged into the expansion slot.

For detailed information, refer to the "Safety Monitor DCS21B/31B" manual, which you can order from SEW-EURODRIVE.

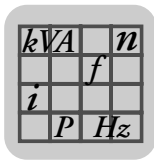

Electronics data

| DCS21B/31B option | | |
|--|--|---|
| <p>DCS21B F LVD B A X80 X81 X82 X83 X84 X85 X86 X87</p> <p>11890AXX</p> | <p>DCS31B X80 X81 X82 X83 X84 X85 X87</p> <p>11891AXX</p> | <p>LED alarm/error LED watchdog LED system B LED system A</p> <p>X80: Power supply connection</p> <p>X81: Connection binary inputs</p> <p>X82: Connection of binary outputs DO0, DO1</p> <p>X83: Connection of binary output DO2</p> <p>X84: Connection of incremental, sin/cos or absolute encoder (encoder 1)</p> <p>X85: Connection of incremental, sin/cos or absolute encoder (encoder 2)</p> <p>X86: CAN bus connection (only for DCS21B)</p> <p>X87: Connection of service interface</p> |

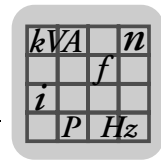

2.40 MOVI-PLC® basic DHP11B.. controller option

Part numbers

The MOVI-PLC® basic controller DHP11B.. is available in 3 versions, which differ in the modules available from a range of libraries.

| Part number | MOVI-PLC® basic DHP11B.. unit version | Description |
|-------------|---------------------------------------|--|
| 1820 472 4 | DHP11B-T0 | MOVI-PLC® basic controller |
| 1820 822 3 | DHP11B-T1 | Application version I (in addition to version T0, enables additional functions including electronic cam and synchronous operation) |
| 1820 823 1 | DHP11B-T2 | Application version II (in addition to version T1, enables additional functions including handling) |

Description

MOVI-PLC® is a series of controllers available from SEW-EURODRIVE. MOVI-PLC® can be programmed by users according to IEC 61131-3 and PLCopen.

The MOVI-PLC® basic controller DHP11B.. is equipped with a PROFIBUS DP-V1 slave interface, two SBus interfaces (CAN), RS485 and eight digital inputs/outputs, five of which are interrupt-capable. MOVI-PLC® basic DHP11B.. can control 12 units at the same time (MOVIDRIVE® B/compact, MOVITRAC® 07/B, MOVIAxis®, MOVIMOT®).

Electronics data

| MOVI-PLC® basic DHP11B.. option | | |
|--|-------------------------|--|
| <p>DHP 11B X31 X32 X33 X30 X34 T0 11886AXX</p> | Status displays | LEDs for the voltage supply to the I/Os, firmware, program, PROFIBUS, System buses |
| | Fieldbus | <ul style="list-style-type: none"> PROFIBUS DP and DP-V1 to IEC 61158 Automatic detection of baud rate from 9.6 kbaud to 12 Mbaud Bus termination with suitable connector to implement GSD file SEW_6007.GSD DP ident. number 6007_{hex} (24579_{dec}) Maximum 32 process data |
| | System bus | <ul style="list-style-type: none"> 2 system buses (CAN) for control of 12 inverters and CANopen I/O modules CAN layer 2 (SCOM cyclic, acyclic) or via the SEW MOVILINK® protocol Baud rate: 125 kbaud ... 1 Mbaud External bus terminator Address range: 0 ... 127 |
| | Engineering | Via RS485, PROFIBUS and the system buses |
| | Panel operation | Via RS485 and CAN 2 (in preparation) |
| | Connection technology | <ul style="list-style-type: none"> PROFIBUS: 9-pin Sub-D connector to IEC61158 System buses and I/Os: plug-in terminals RS485: RJ10 |
| | Binary inputs / outputs | 8 I/Os to IEC 61131-2; can be configured as inputs or outputs. Five are interrupt-capable |
| | Memory | <ul style="list-style-type: none"> Program: 512 kByte Data: 128 kByte Retain: 24 kByte |
| | Tools for startup | MOVITOOLS® MotionStudio with integrated PLC editor (Programming languages IL, ST, LD, FBD, CFC, SFC; libraries to optimize control of the inverters) |

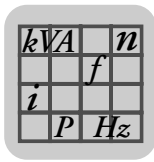

2.41 OST11B option

Part number 1820 544 5

Description

Option OST11B provides an additional RS485 interface (COM2) for MOVI-PLC[®] *basic* DHP11B.. in terminal design or as an engineering interface. Only use option OST11B in conjunction with MOVI-PLC[®] *basic* DHP11B...

When the MOVI-PLC[®] *basic* DHP11B.. option is plugged into the fieldbus slot, option OST11B is plugged into the encoder slot. When the MOVI-PLC[®] *basic* DHP11B.. option is plugged into the expansion slot, option OST11B is installed in the expansion slot above the option MOVI-PLC[®] *basic* DHP11B...

Electronics data

| OST11B option | | |
|-----------------|--|--|
| <p>11887AXX</p> | RS485 interface COM2 X35:1 ... X35:4 X36:1 ... X36:3 | <ul style="list-style-type: none"> For connection of an Engineering PC, a DOP11A/B operator terminal or a gear-motor with integrated frequency inverter MOVIMOT[®] I/O standard, 57.6 kBaud, max. total cable length 200 m, integrated dynamic terminating resistor permanently installed |
| | Potential level | COM2 is isolated from the MOVI-PLC [®] <i>basic</i> DHP11B.. controller |

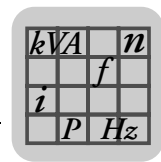

2.42 MOVI-PLC® advanced controller option DH.41B

Part numbers

The MOVI-PLC® advanced DH.41B is available in 2 variants, which differ in the integrated fieldbus interfaces:

| Part number | Unit design of MOVI-PLC® advanced DH.41B | Fieldbus interfaces |
|-------------|--|--------------------------------------|
| 1821 160 7 | DHE41B | Ethernet TCP/IP, UDP |
| 1821 161 5 | DHF41B | Ethernet TCP/IP, UDP, PROFIBUS DP-V1 |

The MOVI-PLC® advanced controller DH.41B is available as

- **control card** MOVI-PLC® advanced DH.41B as an option for MOVIDRIVE® B and MOVITRAC® B inverters and for MOVIAXIS® servo inverters
- **compact controller** MOVI-PLC® advanced DHE41B/UOH11B or DHF41B/UOH21B prepared for installation on a DIN rail. As a compact controller, it is designed for controlling inverters.

Description

MOVI-PLC® is a series of controllers available from SEW-EURODRIVE. MOVI-PLC® can be programmed by users according to IEC 61131-3 and PLCOpen.

The MOVI-PLC® advanced controller DH.41B is equipped with numerous communication interfaces.

The two system bus interfaces CAN 1 and CAN 2 are used primarily for connecting and controlling several inverters and integrating decentralized I/O modules. SEW-EURODRIVE recommends connecting a maximum of 256 inputs and 256 outputs to the MOVI-PLC® advanced DH.41B controller.

This machine module can be operated via the integrated fieldbus interface with a higher-level controller.

Engineering is carried out using the powerful Ethernet 1 interface or USB interface (in preparation).

An operator terminal (e.g. DOP11A/B) or a MOVIMOT® gearmotor with integrated frequency inverter are connected to the RS485 interfaces.

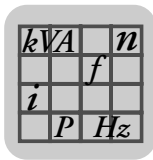

Electronics data for DHE41B

| MOVI-PLC® advanced DHE41B option | | |
|----------------------------------|----------------------------|--|
| <p>11888AXX</p> | Electrical supply | <p>The following applies for all units (MDX, MX, compact controller):</p> <ul style="list-style-type: none"> You will have to supply the binary inputs and outputs with DC 24 V (X31:1/2) separately. <p>Integrated in MOVIDRIVE® MDX61B:</p> <ul style="list-style-type: none"> Power consumption: $P_{\max} = 6.8 \text{ W}$ The MOVI-PLC® advanced DHE41B controller is supplied by MOVIDRIVE® MDX61B via backplane connector. In the case of disconnection from the power supply, continued function is guaranteed by DC 24 backup (external DC 24 V supply to X10:9/10 of MOVIDRIVE® MDX61B required). <p>Installed in the MOVIAXIS® master module (MXM):</p> <ul style="list-style-type: none"> Power consumption: $P_{\max} = 8.5 \text{ W}$ $U = \text{DC } 24 \text{ V } (-15 \% / +20 \%)$ $I_{\max} = 600 \text{ mA}$ The MOVI-PLC® advanced DHE41B.. controller can be supplied by the MOVIAXIS® switched mode power supply module (MXS) or from an external voltage supply. For this purpose, connect X5 between the individual devices. If the MOVI-PLC® advanced DHE41B controller is supplied with DC 24 V by the MOVIAXIS® switched-mode power supply module, the function of the MOVI-PLC® advanced DHE41B.. controller is maintained after disconnection from the line voltage (external DC 24 V supply at X16 of the MOVIAXIS® switched-mode power supply module required). |
| | Potential levels | <p>The MOVI-PLC® advanced DHE41B controller has the following potential levels:</p> <ul style="list-style-type: none"> Potential control / CAN 1 / COM1 Potential COM2 Potential binary inputs and outputs Potential system bus CAN 2 |
| | Memory | <ul style="list-style-type: none"> Program memory: 8 MByte (for application program, incl. IEC libraries) Data memory: 4 MByte (for IEC application) Retain data: 32 kByte System variables (retain): 8 kByte |
| | Binary inputs | <p>Isolated (optocoupler), PLC-compatible (IEC 61131-2), cycle time 1 ms, available unfiltered and filtered (filter constant ca. 2 ms)</p> <p>X31:3...X31:10 Can be configured as binary input or output X31:6...X31:10 are interrupt capable (response time <100 ms)</p> |
| | Internal resistance | $R_i \approx 3 \text{ k}\Omega$, $I_E \approx 10 \text{ mA}$ |
| | Signal level | <p>DC (+13 V...+30 V) = "1" = Contact closed (according to IEC 61131)</p> <p>DC (-3 V...+5 V) = "0" = Contact open (according to IEC 61131)</p> |
| | Binary outputs | <p>PLC compatible, (IEC 61131-2) response time 1 ms</p> <p>X31:3...X31:10 Can be configured as binary input or output Maximum permitted output current $I_{A_{\max}} = \text{DC } 150 \text{ mA}$ per binary output All 8 binary outputs can be subject to the maximum approved output current $I_{A_{\max}}$ load at the same time.</p> |
| Signal level | "0" = 0 V "1" = DC+24 V | |

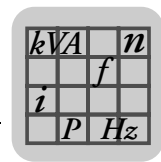

| MOVI-PLC® advanced DHE41B option | | |
|--|--|--|
| System bus CAN 2 X32:1 ... X32:3 System bus CAN 1 X33:1 ... X33:3 | <ul style="list-style-type: none"> System bus CAN 1 and CAN 2 to CAN specification 2.0, parts A and B, transmission technology to ISO 11898, max. 64 stations, The CAN 2 system bus is electrically isolated Max. 64 stations per CAN system bus, Max. 64 SCOM transmit objects / 32 receive objects per CAN system bus Address range 0...127 Baud rate: 125 kBaud...1 MBaud If X32 or X33 is the bus terminator, you must connect a terminating resistor (120 Ω) externally. You can remove connectors X32 or X33 without interrupting the system bus. The system bus can be run in layer 2 (SCOM cyclic, acyclic) or in accordance with the SEW-MOVILINK® protocol. | |
| Ethernet 1 X36 | System bus, reserved | |
| Ethernet 2 X37 | <ul style="list-style-type: none"> TCP/IP Connection options: Engineering PC, other controller, Intranet | |
| USB | USB 1.0 for connecting an engineering PC (in preparation) | |
| RS485 Interface COM1/2 X34:1 ... X34:4 | <ul style="list-style-type: none"> For connection of an engineering PC, a DOP11A/B operator terminal or a MOVIMOT® gearmotor with integrated frequency inverter I/O standard, 57.6 / 9.6 kBaud, max. cable length 200 m Dynamic terminating resistor with fixed installation | |
| SD memory card | <ul style="list-style-type: none"> PC readable Includes: <ul style="list-style-type: none"> Firmware IEC program Data At least 128 MB memory Designs, part numbers, and functions: <ul style="list-style-type: none"> OMH41B-T0: 1821 204 2 Functions: Handling of speed control, positioning, e.g. with the MPLCMotion_MDX library OMH41B-T1: 1821 205 0 Functions: Additional: cam disk, electronic gear, cam controller, for example OMH41B-T2: 1821 206 9 Functions: Additional: material handling, for example | |
| Engineering | <p>Engineering takes place via one of the following interfaces:</p> <ul style="list-style-type: none"> Ethernet 2 (X37) In preparation: USB (X35) <p>The engineering of all SEW components connected to the MOVI-PLC® advanced DHE41B controller can be carried out using the MOVI-PLC® advanced DHE41B controller. Engineering of the MOVI-PLC® advanced DHE41B controller cannot be performed via the inverters.</p> <ul style="list-style-type: none"> MOVITOOLS® MotionStudio PC software with PLC-Editor | |

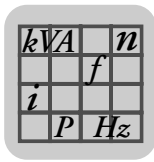

Electronics data for DHF41B

| | |
|--|--|
| | NOTE |
| | For connections identical with DHE41B, refer to the "Electronics data for DHE41B" section. |

| MOVI-PLC® advanced DHF41B option | | |
|----------------------------------|---|--|
| | Potential levels | The MOVI-PLC® advanced DHF41B controller has the following potential levels: <ul style="list-style-type: none"> • Potential control / CAN 1 / COM1 • Potential COM2 • Potential binary inputs and outputs • Potential system bus CAN 2 • Potential PROFIBUS |
| | PROFIBUS connection X30P:1 ... X30P:9 | Via 9-pin sub D connector, pin assignment according to IEC 61158 |
| | Bus terminator | Not integrated. Activate bus termination with suitable PROFIBUS connector with switchable terminating resistors |
| | Automatic baud rate recognition | 9.6 kBaud ... 12 MBaud |
| | Protocol options | PROFIBUS DP and DP-V1 to IEC 61158 |
| | GSD file | SEW_6007.GSD |
| | DP ID number | Not yet assigned |
| | DeviceNet connection X30D:1 ... X30D:5 | <ul style="list-style-type: none"> • 2-wire bus and 2-wire supply voltage DC 24 V with 5-pole Phoenix terminal • Pin assignment according to DeviceNet specification |
| | Communication protocol | Master/slave connection set according to DeviceNet specification version 2.0 |
| | Number of process data words | <ul style="list-style-type: none"> • Programmable via IEC function (0 ... 64 process data words) • A parameter channel can be used as option in addition to the process data words. |
| Baud rate | 125, 250 or 500 kBaud, can be set using DIP switches 2 ⁶ and 2 ⁷ | |
| Bus cable length | For thick cable according to DeviceNet specification 2.0 appendix B: <ul style="list-style-type: none"> • 500 m at 125 kBaud • 250 m at 250 kBaud • 100 m at 500 kBaud | |
| Transmission level | ISO 11 98 - 24 V | |
| MAC ID | 0 ... 63, can be set using DIP switch 2 ⁰ ... 2 ⁵ Max. 64 stations | |
| Supported services | <ul style="list-style-type: none"> • Polled I/O: 1 ... 10 words • Bit-strobe I/O: 1 ... 4 words • Explicit messages: <ul style="list-style-type: none"> – Get_Attribute_Single – Set_Attribute_Single – Reset – Allocate_MS_Connection_Set – Release_MS_Connection_Set | |

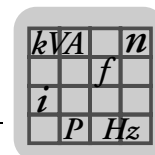

2.43 Braking resistor type BW... option / BW...-T / BW...-P

General information

- Braking resistors BW... / BW...-T and BW...-P match the technical features of the MOVIDRIVE® inverters.
- Take account of a power reduction of 4 % per 10 K from an ambient temperature of 40 °C. Do not exceed a maximum ambient temperature of 80 °C.

PTC resistor BW090-P52B

- Direct installation on MOVIDRIVE® MDX60B/61B size 0 (0005 ... 0014) (→ chapter "Dimension drawings MOVIDRIVE® MDX60B")
- The MOVIDRIVE® units can be lined up even with mounted braking resistor BW090-P52B.
- The resistor protects itself (reversible) against regenerative overload by changing abruptly to high resistance and no longer consuming any more energy. The inverter then switches off and signals a brake chopper fault (F04).

Flat-type braking resistors

- Protection against contact (IP54)
- Internal thermal overload protection (non-replaceable fuse)
- Touch guard and mounting rail attachment available from SEW as accessories

Wire and grid resistors

- Perforated sheet cover (IP20) open to mounting surface
- The short-term load capacity of the wire and grid resistors is higher than in the flat-type braking resistors (→ MOVIDRIVE® MDX60B/61B system manual, chapter. "Selecting the braking resistor")
- A temperature switch is integrated in the BW...-T braking resistor
- A thermal overcurrent relay is integrated in the BW...-P braking resistor

SEW-EURODRIVE recommends also protecting the wire and grid resistors against overload using a bimetallic relay with trip characteristics of trip class 10 or 10A (in accordance with EN 60947-4-1). Set the trip current to the value I_F (→ following tables). Do not use electronic or electromagnetic fuses because these can be triggered even in case of short-term excess currents that are still within the tolerance range.

For braking resistors of the BW...-T / BW...-P series, you can connect the integrated temperature sensor / overcurrent relay using a 2-core, shielded cable as an alternative to a bimetallic relay. The cable entry for the BW...-T and BW...-P braking resistors can be run from the front or the back (→ dimension drawing for BW... / BW...-T / BW...-P braking resistors). Use filler plugs for tapped holes that are not connected.

The resistor surfaces will heat up under a load of P_N . Make sure that you select an installation site that will accommodate these high temperatures. As a rule, braking resistors are therefore mounted on the control cabinet roof.

The performance data listed in the tables below show the load capacity of the braking resistors according to their cyclic duration factor (cyclic duration factor = cdf of the braking resistor in % in relation to a cycle duration ≤ 120 s).

UL and cUL approval

Type BW... braking resistors are UL and cUL approved in conjunction with MOVIDRIVE® B inverters. SEW-EURODRIVE will provide a certificate on request. The BW...-T and BW...-P braking resistors have cRUus approval independent of the MOVIDRIVE® inverters.

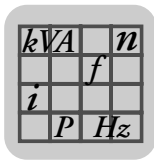

Parallel connection

Two braking resistors with the same value must be connected in parallel for some inverter/resistor combinations. In this case, the trip current must be set on the bimetallic relay to twice the value of I_F entered in the table. For the BW...-T BW...-P braking resistors, the temperature switch/overcurrent relay must be connected in series.

Assignment to AC 400/500 V units (...-5_3)

| Braking resistor type BW... | BW090-P52B | BW100-005 | BW100-006 | BW072-003 | BW072-005 | BW168 | BW268 |
|---|------------------------|-------------------------|--|------------------------|--------------------|--|----------------------|
| Part number | 824 563 0 | 826 269 1 | 821 701 7 | 826 058 3 | 826 060 5 | 820 604 X | 820 715 1 |
| Braking resistor type BW...-T | | | BW100-006-T | | | BW168-T | BW268-T |
| Part number | | | 1820 419 8 | | | 1820 133 4 | 1820 417 1 |
| Continuous braking power (= 100% cdf) | 0.10 kW | 0.45 kW | 0.6 kW | 0.23 kW | 0.45 kW | 0.8 kW | 1.2 kW |
| Load capacity at | 50 % cdf ¹⁾ | 0.15 kW | 0.60 kW | 1.1 kW | 0.31 kW | 0.60 kW | 1.4 kW |
| | 25 % cdf | 0.2 kW | 0.83 kW | 1.9 kW | 0.42 kW | 0.83 kW | 2.6 kW |
| | 12 % cdf | 0.4 kW | 1.11 kW | 3.6 kW | 0.58 kW | 1.11 kW | 4.8 kW |
| | 6 % cdf | 0.7 kW | 2.00 kW | 5.7 kW | 1.00 kW | 2.00 kW | 7.6 kW |
| Observe regenerative power limit of the inverter! (= 150 % of the recommended motor power → technical data) | | | | | | | |
| Resistance value R_{BW} | 90 Ω \pm 35 % | 100 Ω \pm 10 % | | 72 Ω \pm 10 % | | 68 Ω \pm 10 % | |
| Trip current (of F16) I_F | - | 0.8 A _{RMS} | 2.4 A _{RMS} | 0.6 A _{RMS} | 1 A _{RMS} | 3.4 A _{RMS} | 4.2 A _{RMS} |
| Design | PTC | Flat-design | Wire resistor on ceramic core | Flat-design | | Wire resistor on ceramic core | |
| Connections / Tightening torque | Cable | Cable | Ceramic terminals 2.5 mm ² (AWG13) 0.5 Nm | Cable | | Ceramic terminals 2.5 mm ² (AWG13) 0.5 Nm | |
| Degree of protection | IP20 | IP54 | IP20 (when installed) | IP54 | | IP20 (when installed) | |
| Ambient temperature ϑ_U | -20 ... +40 °C | | | | | | |
| Type of cooling | KS = Self-cooling | | | | | | |
| For MOVIDRIVE® (recommended) | 0005 ... 0014 | 0005 ... 0022 | 0015 ... 0040 | 0005 ... 0014 | | 0005 ... 0040 | 0015 ... 0040 |

1) cdf = Cyclic duration factor of the braking resistor in relation to a cycle duration $T_D \leq 120$ s.

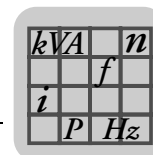

| Braking resistor type BW... | BW147 | BW247 | BW347 | BW039-012 | | |
|---|--|----------------------|----------------------|----------------------|-----------------------|-----------------------|
| Part number | 820 713 5 | 820 714 3 | 820 798 4 | 821 689 4 | | |
| Braking resistor type BW...-T | BW147-T | BW247-T | BW347-T | BW039-012-T | BW039-026-T | BW039-050-T |
| Part number | 1820 134 2 | 1820 084 2 | 1820 135 0 | 1820 136 9 | 1820 415 5 | 1820 137 7 |
| Continuous braking power (= 100% cdf) | 1.2 kW | 2.0 kW | 4.0 kW | 1.2 kW | 2.6 kW | 5.0 kW |
| Load capacity at 50 % cdf ¹⁾ | 2.2 kW | 3.6 kW | 7.2 kW | 2.1 kW | 4.7 kW | 8.5 kW |
| Load capacity at 25 % cdf | 3.8 kW | 6.4 kW | 12.8 kW | 3.8 kW | 8.3 kW | 15.0 kW |
| Load capacity at 12 % cdf | 7.2 kW | 12 kW | 20 kW ²⁾ | 7.2 kW | 15.6 kW | 24.0 kW ²⁾ |
| Load capacity at 6 % cdf | 11 kW | 19 kW | 20 kW ²⁾ | 11.4 kW | 24.0 kW ²⁾ | 24.0 kW ²⁾ |
| Observe regenerative power limit of the inverter! (= 150 % of the recommended motor power → technical data) | | | | | | |
| Resistance value R_{BW} | 47 Ω ±10 % | | | 39 Ω ±10 % | | |
| Trip current (of F16) I_F | 5 A _{RMS} | 6.5 A _{RMS} | 9.2 A _{RMS} | 5.5 A _{RMS} | 8.1 A _{RMS} | 11.3 A _{RMS} |
| Design | Wire resistor on ceramic core | | | | | Grid resistor |
| Connections / tightening torque | Ceramic terminals 2.5 mm ² (AWG13) / 0.5 Nm BW347-T: Ceramic terminals 10 mm ² (AWG18) / 1.6 Nm | | | | | M8 stud / 6 Nm |
| Degree of protection | IP20 (when installed) | | | | | |
| Ambient temperature ϑ_U | -20 ... +40 °C | | | | | |
| Type of cooling | KS = Self-cooling | | | | | |
| For MOVIDRIVE® (recommended) | 0055/0075 | | | 0110 | | |

- 1) cdf = Cyclic duration factor of the braking resistor in relation to a cycle duration $T_D \leq 120$ s.
- 2) Physical power limit due to DC link voltage and resistance value.

| Braking resistor type BW... | BW018-015 | | | |
|---|---|-----------------------|-----------------------|-----------------------|
| Part number | 821 684 3 | | | |
| Braking resistor type BW...-T/-P | BW018-015-P | BW018-035-T | BW018-075-T | BW915-T |
| Part number | 1820 416 3 | 1820 138 5 | 1820 139 3 | 1820 413 9 |
| Continuous braking power (= 100% cdf) | 1.5 kW | 3.5 kW | 7.5 kW | 16 kW |
| Load capacity at 50 % cdf ¹⁾ | 2.5 kW | 5.9 kW | 12.7 kW | 27.2 kW |
| Load capacity at 25 % cdf | 4.5 kW | 10.5 kW | 22.5 kW | 48 kW |
| Load capacity at 12 % cdf | 6.7 kW | 15.7 kW | 33.7 kW | 62.7 kW ²⁾ |
| Load capacity at 6 % cdf | 11.4 kW | 26.6 kW | 52.2 kW ²⁾ | 62.7 kW ²⁾ |
| Observe regenerative power limit of the inverter! (= 150 % of the recommended motor power → technical data) | | | | |
| Resistance value R_{BW} | 18 Ω ±10 % | | | 15 Ω ±10 % |
| Trip current (of F16) I_F | 9.1 A _{RMS} | 13.9 A _{RMS} | 20.4 A _{RMS} | 32.6 A _{RMS} |
| Design | Wire resistor on ceramic core | Grid resistor | | |
| Connections / tightening torque | BW018-015: Ceramic terminals 2.5 mm ² (AWG13) / 0.5 Nm BW018-015-P: Terminal 2.5 mm ² (AWG13) / 1 Nm | Bolt M8 / 6 Nm | | |
| Degree of protection | IP20 (when installed) | | | |
| Ambient temperature ϑ_U | -20 ... +40 °C | | | |
| Type of cooling | KS = Self-cooling | | | |
| For MOVIDRIVE® (recommended) | 0150/0220 and 2 × parallel with 0370/0450 ³⁾ | | | 0220 |

- 1) cdf = Cyclic duration factor of the braking resistor in relation to a cycle duration $T_D \leq 120$ s.
- 2) Physical power limit due to DC link voltage and resistance value.
- 3) When connected in parallel, the load capacity and trip current are doubled.

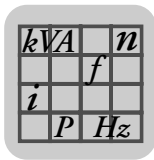

| Braking resistor type BW...- | BW012-025 | | | | |
|--|---|----------------|----------------|---|----------------|
| Part number | 821 680 0 | | | | |
| Braking resistor type BW...-T/-P | BW012-025-P | BW012-050T | BW012-100-T | BW106-T | BW206-T |
| Part number | 1820 414 7 | 1820 140 7 | 1820 141 5 | 1820 083 4 | 1820 412 0 |
| Continuous braking power (= 100% cdf) | 2.5 kW | 5.0 kW | 10 kW | 13.5 kW | 18 kW |
| Load capacity at | 4.2 kW | 8.5 kW | 17 kW | 23 kW | 30.6 kW |
| 50 % cdf ¹⁾ | 7.5 kW | 15.0 kW | 30 kW | 40 kW | 54 kW |
| 25 % cdf | 11.2 kW | 22.5 kW | 45 kW | 61 kW | 81 kW |
| 12 % cdf | 19.0 kW | 38.0 kW | 76 kW | 102 kW | 136.8 kW |
| 6 % cdf | Observe regenerative power limit of the inverter! (= 150 % of the recommended motor power → technical data) | | | | |
| Resistance value R_{BW} | 12 $\Omega \pm 10\%$ | | | 6 $\Omega \pm 10\%$ | |
| Trip current (of F16) I_F | 14.4 A_{RMS} | 20.4 A_{RMS} | 28.8 A_{RMS} | 47.4 A_{RMS} | 54.7 A_{RMS} |
| Design | Grid resistor | | | | |
| Connections / tightening torque | Ceramic terminals 2.5 mm ² (AWG13) / 0.5 Nm BW012-025-P: Terminals 4 mm ² (AWG12) / 1 Nm | | | Bolt M8 / 6 Nm | |
| Degree of protection | IP20 (when installed) | | | | |
| Ambient temperature ϑ_U | -20 ... +40 °C | | | | |
| Type of cooling | KS = Self-cooling | | | | |
| For MOVIDRIVE® (recommended) | 0300 | | | 0370...0750 and 2 × parallel with 0900/1100/1320 ²⁾ | |

- 1) cdf = Cyclic duration factor of the braking resistor in relation to a cycle duration $T_D \leq 120$ s.
- 2) When connected in parallel, the load capacity and trip current are doubled.

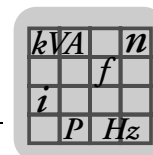

Assignment to AC 230 V units (...-2_3)

| Braking resistor type BW... | BW039-003 | BW039-006 | BW039-012 | | BW027-006 | BW027-012 | | |
|--|--|----------------------|----------------------|----------------------|----------------------|----------------------|--------------------------------------|-----------------------|
| Part number | 821 687 8 | 821 688 6 | 821 689 4 | | 822 422 6 | 822 423 4 | | |
| Braking resistor type BW...-T | | | BW039-012-T | BW039-026-T | | | BW018-015-P | BW018-035-T |
| Part number | | | 1820 136 9 | 1820 415 5 | | | 1820 416 3 | 1820 138 5 |
| Continuous braking power (= 100% cdf) | 0.3 kW | 0.6 kW | 1.2 kW | 2.6 kW | 0.6 kW | 1.2 kW | 1.5 kW | 3.5 kW |
| Load capacity at 50 % cdf ¹⁾ | 0.5 kW | 1.1 kW | 2.1 kW | 4.6 kW | 1.1 kW | 2.1 kW | 2.5 kW | 5.9 kW |
| 25 % cdf | 1.0 kW | 1.9 kW | 3.8 kW | 6.0 kW ²⁾ | 1.9 kW | 3.8 kW | 4.5 kW | 10.5 kW |
| 12 % cdf | 1.8 kW | 3.6 kW | 6.0 kW ²⁾ | 6.0 kW ²⁾ | 3.6 kW | 7.2 kW | 6.7 kW | 13.0 kW ²⁾ |
| 6 % cdf | 2.8 kW | 5.7 kW | 6.0 kW ²⁾ | 6.0 kW ²⁾ | 5.7 kW | 8.7 kW ²⁾ | 11.4 kW | 13.0 kW ²⁾ |
| Observe regenerative power limit of the inverter! (= 150 % of the recommended motor power → technical data) | | | | | | | | |
| Resistance value R_{BW} | 39 Ω ±10 % | | | | 27 Ω ±10 % | | 18 Ω ±10 % | |
| Trip current (of F16) I_F | 2.7 A _{RMS} | 3.9 A _{RMS} | 5.5 A _{RMS} | 8.1 A _{RMS} | 4.7 A _{RMS} | 6.6 A _{RMS} | 9.1 A _{RMS} | 13.9 A _{RMS} |
| Design | Wire resistor | | | | | | Grid resistor | |
| Connections / tightening torque | Ceramic terminals 2.5 mm ² (AWG12) / 0.5 Nm | | | | | | M8 stud / 6 Nm | |
| Degree of protection | IP20 (when installed) | | | | | | | |
| Ambient temperature ϑ_U | -20 ... +40 °C | | | | | | | |
| Type of cooling | KS = Self-cooling | | | | | | | |
| For MOVIDRIVE® (recommended) | 0015/0022 | | | | 0015...0037 | | 2 × parallel with 0110 ³⁾ | |

- 1) cdf = Cyclic duration factor of the braking resistor in relation to a cycle duration $T_D \leq 120$ s.
- 2) Physical power limit due to DC link voltage and resistance value.
- 3) When connected in parallel, the load capacity and trip current are doubled.

| Braking resistor type BW...-T/-P | BW018-075-T | BW915-T | BW012-025-P | BW012-050-T | BW012-100-T | BW106-T | BW206-T |
|--|--------------------------------------|-----------------------|-----------------------|-----------------------|-----------------------|--|-----------------------|
| Part number | 1820 139 3 | 1820 413 9 | 1820 414 7 | 1820 140 7 | 1820141 5 | 1820 083 4 | 1820 412 0 |
| Continuous braking power (= 100% cdf) | 7.5 kW | 15.6 kW ²⁾ | 2.5 kW | 5.0 kW | 10 kW | 13.5 kW | 18 kW |
| Load capacity at 50 % cdf ¹⁾ | 12.7 kW | 15.6 kW ²⁾ | 4.2 kW | 8.5 kW | 17 kW | 23 kW | 30.6 kW |
| 25 % cdf | 13.0 kW ²⁾ | 15.6 kW ²⁾ | 7.5 kW | 15.0 kW | 19.6 kW ²⁾ | 39.2 kW ²⁾ | 39.2 kW ²⁾ |
| 12 % cdf | 13.0 kW ²⁾ | 15.6 kW ²⁾ | 11.2 kW | 19.6 kW ²⁾ | 19.6 kW ²⁾ | 39.2 kW ²⁾ | 39.2 kW ²⁾ |
| 6 % cdf | 13.0 kW ²⁾ | 15.6 kW ²⁾ | 19.0 kW | 19.6 kW ²⁾ | 19.6 kW ²⁾ | 39.2 kW ²⁾ | 39.2 kW ²⁾ |
| Observe regenerative power limit of the inverter! (= 150 % of the recommended motor power → technical data) | | | | | | | |
| Resistance value R_{BW} | 18 Ω ±10 % | 15 Ω ±10 % | 12 Ω ±10 % | | | 6 Ω ±10 % | |
| Trip current (of F16) I_F | 20.4 A _{RMS} | 32.6 A _{RMS} | 14.4 A _{RMS} | 20.4 A _{RMS} | 28.8 A _{RMS} | 47.4 A _{RMS} | 54.7 A _{RMS} |
| Design | Grid resistor | | | | | | |
| Connections / tightening torque | M8 stud / 6 Nm | | | | | | |
| Degree of protection | IP20 (when installed) | | | | | | |
| Ambient temperature ϑ_U | -20 ... +40 °C | | | | | | |
| Type of cooling | KS = Self-cooling | | | | | | |
| For MOVIDRIVE® (recommended) | 2 × parallel with 0110 ³⁾ | | 0055/0075 | | | 0150 and 2 × parallel with 0220/0300 ³⁾ | |

- 1) cdf = Cyclic duration factor of the braking resistor in relation to a cycle duration $T_D \leq 120$ s.
- 2) Physical power limit due to DC link voltage and resistance value.
- 3) When connected in parallel, the load capacity and trip current are doubled.

Technical data of the braking resistor BW...-T / BW...-P

| BW...-T / BW...-P | |
|---|--|
| Connection cross section for signal contact | 1 x 2.5 mm ² |
| Switching capability of the thermostat's signal contact | <ul style="list-style-type: none"> • DC 2 A / DC 24 V (DC11) • AC 2 A / AC 230V (AC11) |
| Switch contact (NC) | according to EN 61800-5-1 |

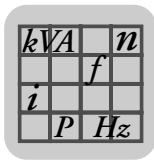

Technical Data and Dimension Sheets

Braking resistor type BW... option / BW...-T / BW...-P

MDimension drawing braking resistors BW... / BW...-T / BW...-P

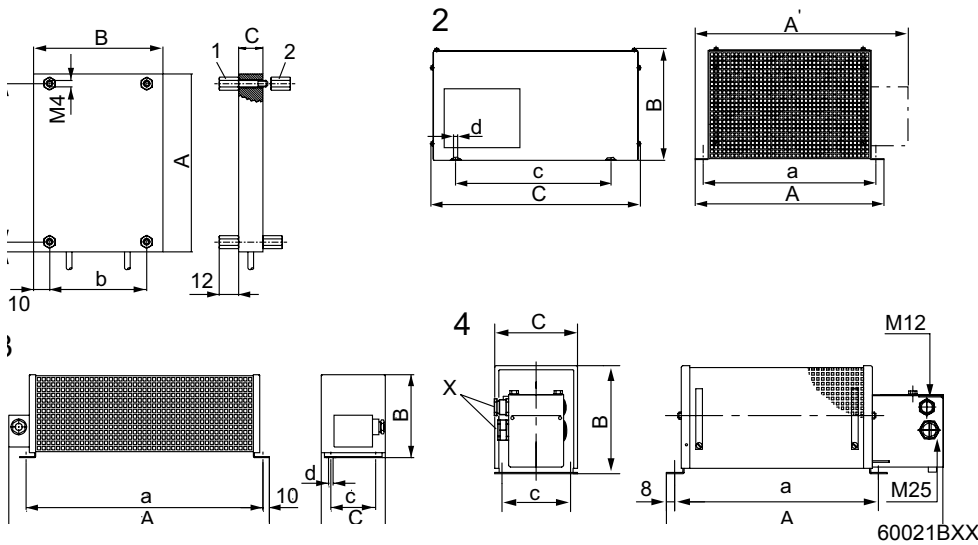

- BW... :
- 1 = Flat design
The connecting lead is 500 mm (19.7 in) long. The scope of delivery includes four M4 stud bolts each of type 1 and 2.
 - 2 = Grid resistor
 - 3 = Wire resistor
 - 4 = Wire resistor with temperature switch (-T/-P)
Cable entry (X) is possible from both sides.

| Type BW... | Mounting position | Main dimensions mm (in) | | | Fastening parts mm (in) | | | Cable gland | Weight kg (lb) |
|------------------|-------------------|-------------------------|------------|------------|-------------------------|------------|-------------|-------------|----------------|
| | | A/A' | B | C | a | b/c | d | | |
| BW...-T/ BW...-P | | | | | | | | | |
| BW106-T | 2 | 795 (31.3) | 270 (10.6) | 490 (19.3) | 770(30.3) | 380 (15) | 10.5 (0.41) | - | 32 (71) |
| BW206-T | 2 | 995 (39.2) | 270 (10.6) | 490 (19.3) | 970 (38.2) | 380 (15) | 10.5 (0.41) | - | 40 (88) |
| BW012-025 | 2 | 295 (11.6) | 260 (10.2) | 490 (19.3) | 270 (10.6) | 380 (15) | 10.5 (0.41) | M12 + M25 | 8.0 (18) |
| BW012-025-P | 2 | 295/355 (11.6)/(14) | 260 (10.2) | 490 (19.3) | 270 (10.6) | 380 (15) | 10.5 (0.41) | M12 + M25 | 8.0 (18) |
| BW012-050-T | 2 | 395 (15.6) | 260 (10.2) | 490 (19.3) | 370 (14.6) | 380 (15) | 10.5 (0.41) | - | 12 (26) |
| BW012-100-T | 2 | 595 (23.4) | 270 (10.6) | 490 (19.3) | 570 (22.4) | 380 (15) | 10.5 (0.41) | - | 21 (46) |
| BW915-T | 2 | 795 (31.3) | 270 (10.6) | 490 (19.3) | 770 (30.3) | 380 (15) | 10.5 (0.41) | - | 30 (66) |
| BW018-015 | 3 | 620 (24.4) | 120 (4.72) | 92 (3.6) | 544 (21.4) | 64 (2.5) | 6.5 (0.26) | PG11 | 4.0 (8.8) |
| BW018-015-P | 4 | 649 (25.6) | 120 (4.72) | 185 (7.28) | 530 (20.9) | 150 (5.91) | 6.5 (0.26) | M12 + M25 | 5.8 (13) |
| BW018-035-T | 2 | 295 (11.6) | 270 (10.6) | 490 (19.3) | 270 (10.6) | 380 (15) | 10.5 (0.41) | - | 9.0 (20) |
| BW018-075-T | 2 | 595 (23.4) | 270 (10.6) | 490 (19.3) | 570 (22.4) | 380 (15) | 10.5 (0.41) | - | 18.5 (40.8) |
| BW027-006 | 3 | 486 (19.1) | 120 (4.72) | 92 (3.6) | 430 (16.9) | 64 (2.5) | 6.5 (0.26) | PG11 | 2.2 (4.9) |
| BW027-012 | 3 | 486 (19.1) | 120 (4.72) | 185 (7.28) | 426 (16.8) | 150 (5.91) | 6.5 (0.26) | PG11 | 4.3 (9.5) |
| BW039-003 | 3 | 286 (11.3) | 120 (4.72) | 92 (3.6) | 230 (9.06) | 64 (2.5) | 6.5 (0.26) | PG11 | 1.5 (3.3) |
| BW039-006 | 3 | 486 (19.1) | 120 (4.72) | 92 (3.6) | 430 (16.9) | 64 (2.5) | 6.5 (0.26) | PG11 | 2.2 (4.9) |
| BW039-012 | 3 | 486 (19.1) | 120 (4.72) | 185 (7.28) | 426 (16.8) | 150 (5.91) | 6.5 (0.26) | PG11 | 4.3 (9.5) |
| BW039-012-T | 4 | 549 (21.6) | 120 (4.72) | 185 (7.28) | 426 (16.8) | 150 (5.91) | 6.5 (0.26) | M12 + M25 | 4.9 (11) |
| BW039-026-T | 4 | 649 (25.6) | 120 (4.72) | 275 (10.8) | 530 (20.9) | 240 (9.45) | 6.5 (0.26) | M12 + M25 | 7.5 (17) |
| BW039-050-T | 2 | 395 (15.6) | 260 (10.2) | 490 (19.3) | 370 (14.6) | 380 (15) | 10.5 (0.41) | - | 12 (26) |
| BW147 | 3 | 465 (18.3) | 120 (4.72) | 185 (7.28) | 426 (16.8) | 150 (5.91) | 6.5 (0.26) | PG13.5 | 4.3 (9.5) |
| BW147-T | 4 | 549 (21.6) | 120 (4.72) | 185 (7.28) | 426 (16.8) | 150 (5.91) | 6.5 (0.26) | M12 + M25 | 4.9 (11) |
| BW247 | 3 | 665 (26.2) | 120 (4.72) | 185 (7.28) | 626 (24.6) | 150 (5.91) | 6.5 (0.26) | PG13.5 | 6.1 (13) |
| BW247-T | 4 | 749 (29.5) | 120 (4.72) | 185 (7.28) | 626 (24.6) | 150 (5.91) | 6.5 (0.26) | M12 + M25 | 9.2 (20) |
| BW347 | 3 | 670 (26.4) | 145 (5.71) | 340 (13.4) | 630 (24.8) | 300 (11.8) | 6.5 (0.26) | PG13.5 | 13.2 (29.1) |
| BW347-T | 4 | 749 (29.5) | 210 (8.27) | 185 (7.28) | 630 (24.8) | 150 (5.91) | 6.5 (0.26) | M12 + M25 | 12.4 (27.3) |
| BW168 | 3 | 365 (14.4) | 120 (4.72) | 185 (7.28) | 326 (12.8) | 150 (5.91) | 6.5 (0.26) | PG13.5 | 3.5 (7.7) |
| BW168-T | 4 | 449 (17.7) | 120 (4.72) | 185 (7.28) | 326 (12.8) | 150 (5.91) | 6.5 (0.26) | M12 + M25 | 3.6 (7.9) |
| BW268 | 3 | 465 (18.3) | 120 (4.72) | 185 (7.28) | 426 (16.8) | 150 (5.91) | 6.5 (0.26) | PG13.5 | 4.3 (9.5) |
| BW268-T | 4 | 549 (21.6) | 120 (4.72) | 185 (7.28) | 426 (16.8) | 150 (5.91) | 6.5 (0.26) | M12 + M25 | 4.9 (11) |
| BW072-003 | 1 | 110 (4.33) | 80 (3.1) | 15 (0.59) | 98 (3.9) | 60 (2.4) | - | - | 0.3 (0.7) |
| BW072-005 | 1 | 216 (8.5) | 80 (3.1) | 15 (0.59) | 204 (8.03) | 60 (2.4) | - | - | 0.6 (1) |
| BW100-005 | 1 | 216 (8.5) | 80 (3.1) | 15 (0.59) | 204 (8.03) | 60 (2.4) | - | - | 0.6 (1) |
| BW100-006 | 4 | 486 (19.1) | 120 (4.72) | 92 (3.6) | 430 (16.9) | 64 (2.5) | 6.5 (0.26) | PG11 | 2.2 (4.9) |
| BW100-006-T | 4 | 549 (21.6) | 120 (4.72) | 92 (3.6) | 430 (16.9) | 80 (3.1) | 6.5 (0.26) | M12 + M25 | 3.0 (6.6) |

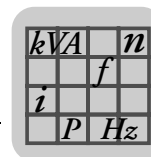

Touch guard BS... A BS.. touch guard is available for braking resistors in flat design.

| Touch guard | BS003 | BS005 |
|----------------------|------------------------|-------------------------------------|
| Part number | 813 151 1 | 813 152 X |
| for braking resistor | BW027-003 BW072-003 | BW027-005 BW072-005 BW100-005 |

Dimensions drawing for BS...

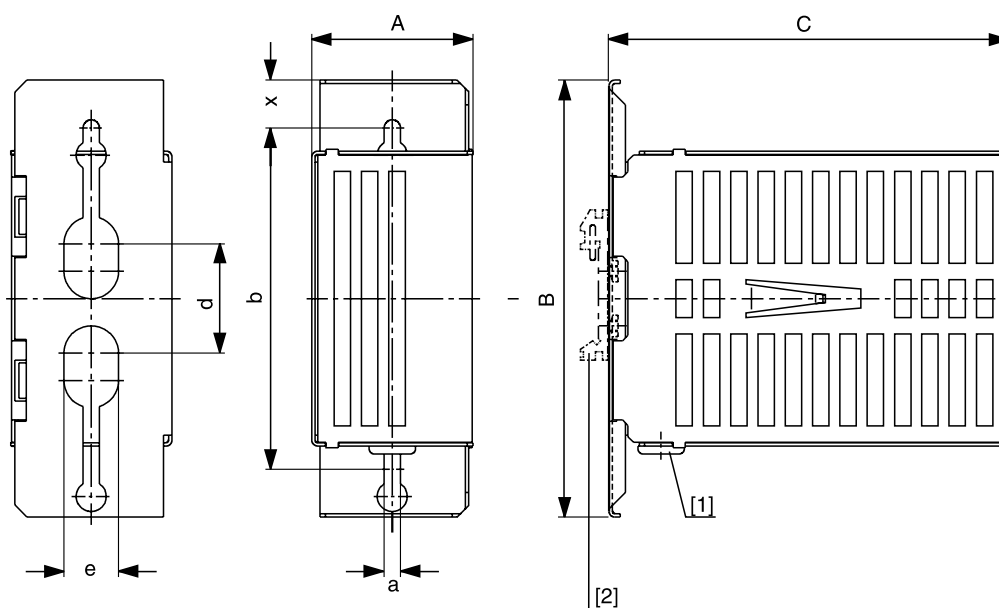
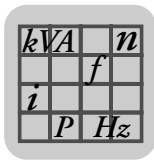

Figure 26: Dimension drawing, BS touch guard with grommet [1] and support rail mounting [2] 05247AXX

| Type | Main dimensions mm (in) | | | Mounting dimensions mm (in) | | | | | Weight kg (lb) |
|--------|-------------------------|-----------|------------|-----------------------------|----------|-----------|---------|-------------|----------------|
| | A | B | C | b | d | e | a | x | |
| BS-003 | 60 (2.4) | 160 (6.3) | 146 (5.75) | 125 (4.92) | 40 (1.6) | 20 (0.79) | 6 (0.2) | 17.5 (0.69) | 0.35 (0.77) |
| BS-005 | 60 (2.4) | 160 (6.3) | 252 (9.92) | 125 (4.92) | 4 (1.6) | 20 (0.79) | 6 (0.2) | 17.5 (0.69) | 0.5 (1) |

Mounting rail installation

A mounting rail attachment HS001 is available from SEW-EURODRIVE, part number 822 194 4, for mounting the touch guard on a mounting rail.



DKB11A heat sink for braking resistors in flat design

Part number 814 345 5

Description

The DKB11A heat sink for braking resistors in flat design provides a space-saving means for mounting the braking resistors (BW072-005, BW100-005) beneath MOVIDRIVE® size 1 units (400/500 V units: 0015...0040; 230 V units: 0015...0037). The resistor is inserted into the heat sink and attached using the supplied screws (M4 × 20).

Dimension drawing

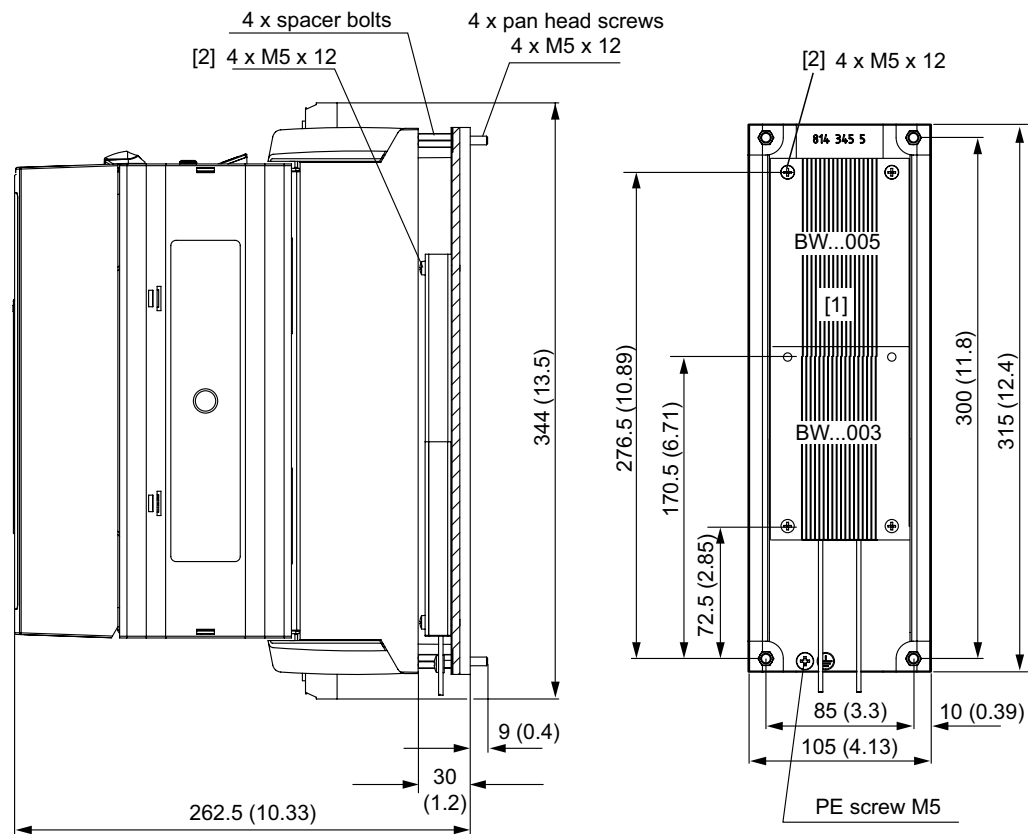

62085AEN

Figure 27: Dimensions, DKB11A heat sink for brake resistors in flatpack design, all in mm (in)

[1] Mounting surface for the braking resistor

[2] Retaining screws are not included in the delivery scope

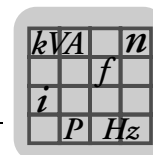

2.44 Line choke option type ND..

- To increase overvoltage protection.
- To limit the charging current when several inverters are connected together in parallel on the input end with shared mains contactors (rated current of line choke = total of inverter currents).
- ND.. line filters have cRUus approval independent of the MOVIDRIVE® inverters.

| Line choke type | ND020-013 | ND030-023 ¹⁾ | ND045-013 | ND085-013 | ND150-013 | ND200-0033 | ND300-0053 |
|--|--|---|---|---|-----------------------------|----------------|-----------------------------------|
| Part number | 826 012 5 | 827 151 8 | 826 013 3 | 826 014 1 | 825 548 2 | 826 579 8 | 827 721 4 |
| Rated power supply voltage V_{supply} (according to EN 50160) | 3 × AC 380 V - 500 V, 50/60 Hz | | | | | | |
| Rated current ²⁾ I_N | AC 20 A | AC 30 A | AC 45 A | AC 85 A | AC 150 A | AC 200 A | AC 300 A |
| Power loss at bei I_N P_V | 10 W | 30 W | 15 W | 25 W | 65 W | 100 W | 280 W |
| Inductance L_N | 0.1 mH | 0.2 mH | 0.1 mH | 0.1 mH | 0.1 mH | 0.03 mH | 0.05 mH |
| Ambient temperature ϑ_U | -25 ... +45 °C | | | | | | |
| Degree of protection | IP 00 (EN 60529) | | | | | | |
| Connections | Terminal strips 4 mm ² (AWG12) | Terminal strips 2.5 mm ² ... 10 mm ² (AWG13 ... AWG8) | Terminal strips 10 mm ² (AWG8) | Terminal strips 35 mm ² (AWG2) | M10 stud PE: M8 stud | | M12 stud PE: 2 × M10 |
| Tightening torque | 0.6 ... 0.8 Nm | max. 2.5 Nm | | 3.2 ... 3.7 Nm | M10 stud: 10 Nm PE: 6 Nm | | M12 stud: 15.5 Nm PE: 10 Nm |
| Assignment to AC 400/500 V units (MDX60/61B...-5_3) | | | | | | | |
| Rated operation (100 %) | 0005...0075 | 0110...0220 | | 0300...0450 and MDR60A0370 | 0550/0750 | MDR60A 0750 | 0900...1320 |
| Increased power (125 %) | 0005...0075 | 0110/0150 | | 0220...0370 | 0450...0750 | | |
| Assignment to 230 V units (MDX61B...-2_3) | | | | | | | |
| Rated operation (100 %) | 0015...0055 | - | 0075/0110 | 0150/0220 | 0300 | - | - |
| Increased power (125 %) | 0015...0037 | - | 0055/0075 | 0110/0150 | 0220/0300 | - | - |

- 1) Use ND030-023 for DC link connection without regenerative power supply unit in connection type A or B (see system manual MOVIDRIVE® MDR60A regenerative power supply).
- 2) If more than one MOVIDRIVE® is connected to a line choke, the **total value of the rated currents** of the connected units **must not exceed the rated current of the line choke!**

Dimension drawings for ND...

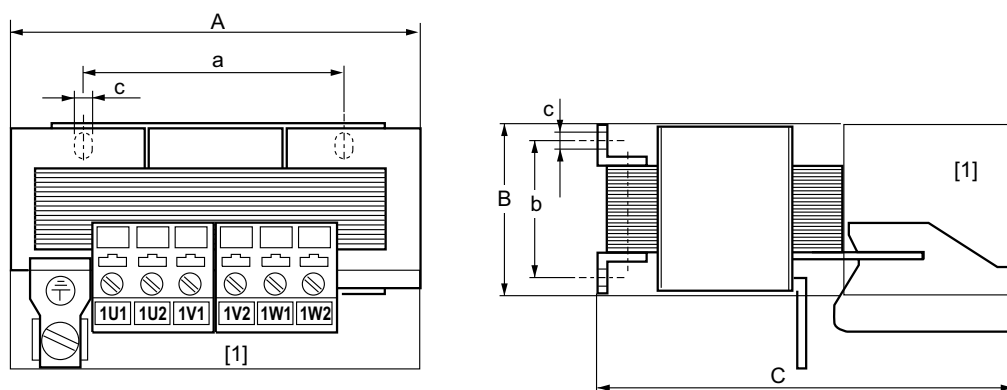

58699AXX

Figure 28: Dimension drawing for line chokes ND020.. / ND030.. / ND045.. / ND085..

[1] Space for installation terminals Input: 1U1, 1V1, 1W1
Any mounting position Output: 1U2, 1V2, 1W2

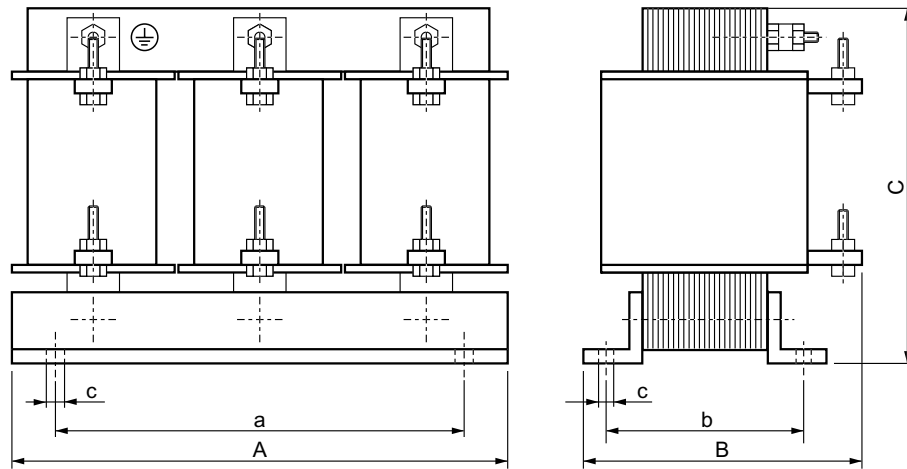
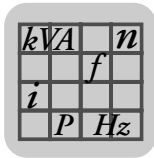

58315AXX

Figure 29: Dimension drawing for line chokes ND150.. / ND200.. / ND300..

| Line choke type | Main dimensions mm (in) | | | Mounting dimensions mm (in) | | Hole dimension mm (in) | Weight kg (lb) |
|------------------------|-------------------------|------------|------------|-----------------------------|---------------------|------------------------|----------------|
| | A | B | C | a | b | c | |
| ND020-013 | 85 (3.3) | 60 (2.4) | 120 (4.72) | 50 (2) | 31 - 42 (1.2 - 1.7) | 5 - 10 (0.2 - 0.39) | 0.5 (1) |
| ND030-023 ND045-013 | 125 (4.92) | 95 (3.7) | 170 (6.69) | 84 (3.3) | 55-75 (2.2 - 3) | 6 (0.24) | 2.5 (5.5) |
| ND085-013 | 185 (7.28) | 115 (4.53) | 235 (9.25) | 136 (5.35) | 56 - 88 (2.2 - 3.5) | 7 (0.28) | 8 (18) |
| ND150-013 | 255 (10) | 140 (5.51) | 230 (9.06) | 170 (6.69) | 77 (3) | 8 (0.31) | 17 (37) |
| ND200-0033 | 250 (9.84) | 160 (6.3) | 230 (9.06) | 180 (7.09) | 98 (3.9) | 8 (0.31) | 15 (33) |
| ND300-0053 | 300 (11.8) | 190 (7.48) | 295 (11.6) | 255 (10) | 145 (5.71) | 11 (0.43) | 35 (77) |

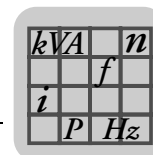

2.45 Line filter type NF...-... option

- To suppress interference emission on the line side of inverters.
- Do not switch between the NF... line filter and MOVIDRIVE®.
- NF.. line filters have cRUus approval independent of the MOVIDRIVE® inverters.

| Line filter type | NF009-503 | NF014-503 | NF018-503 | NF035-503 | NF048-503 |
|--|--------------------------------|-----------|----------------------------|----------------------------|-----------|
| Part number | 827 412 6 | 827 116 X | 827 413 4 | 827 128 3 | 827 117 8 |
| Rated mains voltage V_N (according to EN 50160) | 3 × AC 380 V - 500 V, 50/60 Hz | | | | |
| Rated current I_N | AC 9 A | AC 14 A | AC 18 A | AC 35 A | AC 48 A |
| Power loss at bei I_N P_V | 6 W | 9 W | 12 W | 15 W | 22 W |
| Earth-leakage current at V_N | < 25 mA | < 25 mA | < 25 mA | < 25 mA | < 40 mA |
| Ambient temperature ϑ_U | -25 ... +40 °C | | | | |
| Degree of protection | IP20 (EN 60529) | | | | |
| Connections L1-L3/L1'-L3' | 4 mm ² (AWG 10) | | 10 mm ² (AWG 8) | 10 mm ² (AWG 8) | |
| Tightening torque L1-L3/L1'-L3' | 0.8 Nm | | 1.8 Nm | 1.8 Nm | |
| Connection PE | M5 stud | | M5 stud | M6 stud | |
| Tightening torque PE | 3.4 Nm | | 3.4 Nm | 5.5 Nm | |
| Assignment to AC 400/500 V units (MDX60/61B...-5_3) | | | | | |
| Rated operation (100 %) | 0005...0040 | 0055/0075 | - | 0110/0150 | 0220 |
| Increased power (125 %) | 0005...0030 | 0040/0055 | 0075 | 0110 | 0150 |
| Assignment to 230 V units (MDX61B...-2_3) | | | | | |
| Rated operation (100 %) | 0015/0022 | 0037 | - | 0055/0075 | 0110 |
| Increased power (125 %) | 0015 | 0022 | 0037 | 0055/0075 | - |

| Line filter type | NF063-503 | NF085-503 | NF115-503 | NF150-503 | NF210-503 | NF300-503 |
|--|--------------------------------|-------------------------------|--------------------------------|--------------------------------|--------------------------------|-----------------------------------|
| Part number | 827 414 2 | 827 415 0 | 827 416 9 | 827 417 7 | 827 418 5 | 827 419 3 |
| Rated mains voltage V_N (according to EN 50160) | 3 × AC 380 V - 500 V, 50/60 Hz | | | | | |
| Rated current I_N | AC 63 A | AC 85 A | AC 115 A | AC 150 A | AC 210 A | AC 300 A |
| Power loss at I_N P_V | 30 W | 35 W | 60 W | 90 W | 150 W | 180 W |
| Earth-leakage current at V_N | < 30 mA | < 30 mA | < 30 mA | < 30 mA | < 40 mA | < 45 mA |
| Ambient temperature ϑ_U | -25 ... +40 °C | | | | | |
| Degree of protection | IP20 (EN 60529) | | | | | |
| Connections L1-L3/L1'-L3' | 16 mm ² (AWG 6) | 35 mm ² (AWG 2) | 50 mm ² (AWG1/0) | 50 mm ² (AWG1/0) | 95 mm ² (AWG4/0) | 150 mm ² (AWG300-2) |
| Tightening torque L1-L3/L1'-L3' | 3 Nm | 3.7 Nm | 3.7 Nm | 3.7 Nm | 20 Nm | 30 Nm |
| Connection PE | M6 | M8 | M10 | M10 | M10 | M12 |
| Tightening torque PE | 5.5 Nm | 12.8 Nm | 23.8 Nm | 23.8 Nm | 23.8 Nm | 36 Nm |
| Assignment to AC 400/500 V units (MDX60/61B...-5_3) | | | | | | |
| Rated operation (100 %) | 0300 | 0370/0450 | 0550 | 0750 | 0900/1100 | 1320 |
| Increased power (125 %) | 0220 | 0300/0370 | 0450 | 0550/0750 | 0900 | 1100/1320 |
| Assignment to 230 V units (MDX61B...-2_3) | | | | | | |
| Rated operation (100 %) | 0150 | 0220 | 0300 | - | - | - |
| Increased power (125 %) | 0110/0150 | - | 0220/0300 | - | - | - |

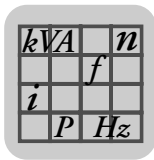

Dimension drawing for NF...

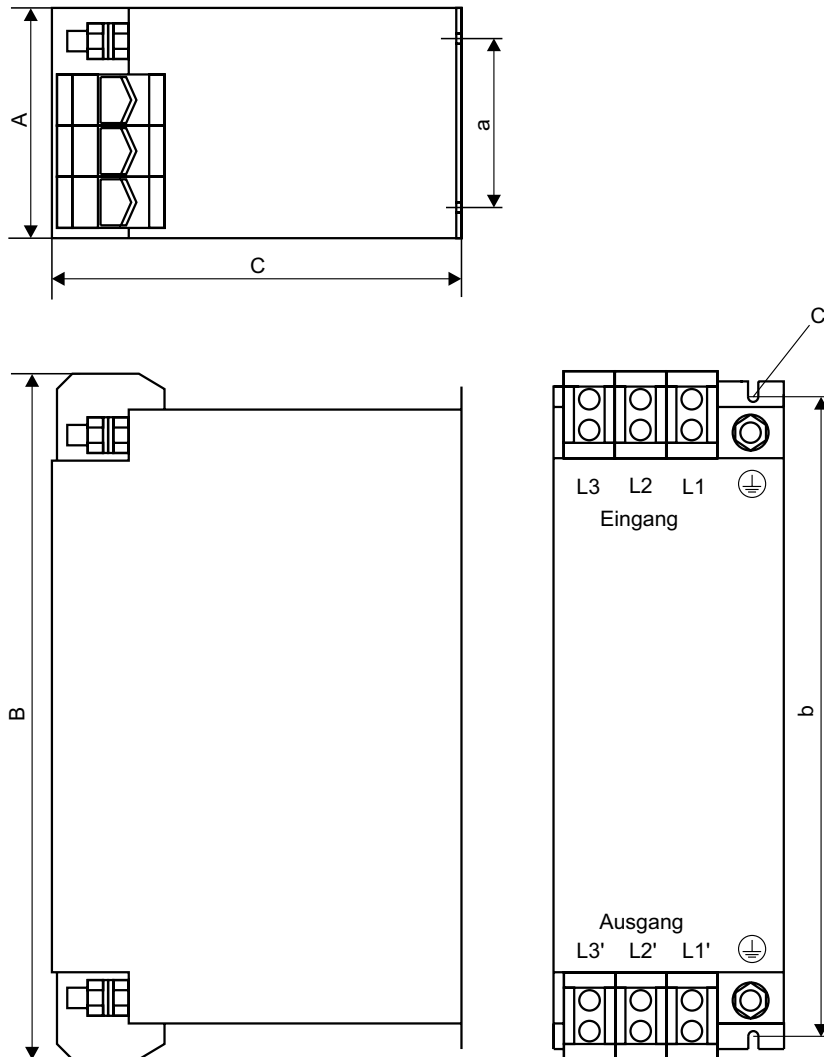

55862ADE

Figure 30: Dimension drawing for NF line filter
Any mounting position

| Line filter type | Main dimensions mm (in) | | | Mounting dimensions mm (in) | | Hole dimension mm (in) c | PE connection | Weight kg (lb) | | |
|------------------|-------------------------|------------|------------|-----------------------------|------------|-----------------------------|---------------|----------------|-----------|-----------|
| | A | B | C | a | b | | | | | |
| NF009-503 | 55 (2.2) | 195 (7.68) | 80 (3.1) | 20 (0.78) | 180 (7.09) | 5.5 (0.22) | M5 | 0.8 (2) | | |
| NF014-503 | | 225 (8.86) | | | 210 (8.27) | | | 0.9 (2) | | |
| NF018-503 | 255 (10) | 240 (9.45) | | | 1.1 (2.4) | | | | | |
| NF035-503 | 60 (2.36) | 275 (10.8) | 100 (3.94) | 30 (1.18) | 255 (10) | | | 6.5 (0.26) | M6 | 1.7 (3.7) |
| NF048-503 | | 315 (12.4) | | | 295 (11.6) | | | | | 2.1 (4.6) |
| NF063-503 | 90 (3.54) | 260 (10.2) | 140 (5.51) | 60 (2.36) | 235 (9.25) | | | | | M8 |
| NF085-503 | | 320 (12.6) | | | 255 (10) | 3.5 (7.7) | | | | |
| NF115-503 | 100 (3.94) | 330 (13) | 155 (6.1) | 65 (2.56) | 255 (10) | M12 | M12 | 4.8 (11) | | |
| NF150-503 | | 330 (13) | | | | | | 155 (6.1) | 65 (2.56) | 255 (10) |
| NF210-503 | 140 (5.51) | 450 (17.7) | 190 (7.48) | 102 (4.02) | 365 (14.4) | | | 6.5 (0.26) | M12 | 8.9 (20) |
| NF300-503 | 170 (6.69) | 540 (21.3) | 230 (9.06) | 125 (4.92) | 435 (17.1) | 12.2 (26.9) | | | | |

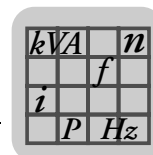

2.46 HD... output choke option

- For suppression of interference from the unshielded motor cable. For HD001 to HD003 we recommend routing the motor cable through the output choke with 5 loops. Only 5 loops are possible if the cable has a large diameter. To make up for this, 2 or 3 output chokes should be connected in series. Connect in series two output chokes in case of 4 windings and three output chokes in case of 3 windings.
- Output chokes HD001 to HD003 are allocated using the cable cross sections of the motor feeders. Consequently, there is no separate assignment table for the AC 230 V units.
- The HD004 output choke is assigned to size 6 units (0900... 1320).

| Output choke type | HD001 ¹⁾ | HD002 ¹⁾ | HD003 output choke ¹⁾ | HD004 ²⁾ |
|--|---------------------------------------|--------------------------------|----------------------------------|----------------------------|
| Part number | 813 325 5 | 813 557 6 | 813 558 4 | 816 885 7 |
| Max. power loss P_{Vmax} | 15 W | 8 W | 30 W | 100 W |
| For cable cross sections/connections/tightening torque | 1.5...16 mm ² (AWG 16...6) | ≤ 1.5 mm ² (AWG 16) | ≥ 16 mm ² (AWG 6) | M12 terminal stud 20 Nm |
| Degree of protection | - | - | - | IP10 |

1) The output choke type HD... is not a UL/cUL-relevant component.

2) UL/cUL approval is not available for the HD0044 output choke

Dimension drawing for HD

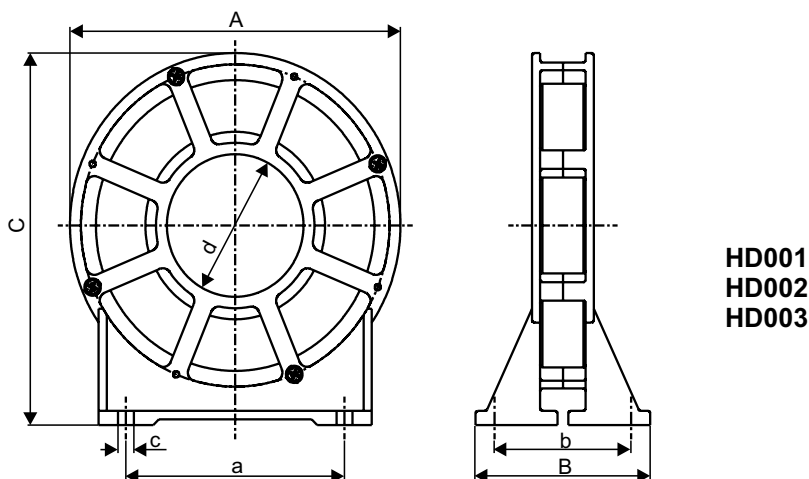

58419AXX

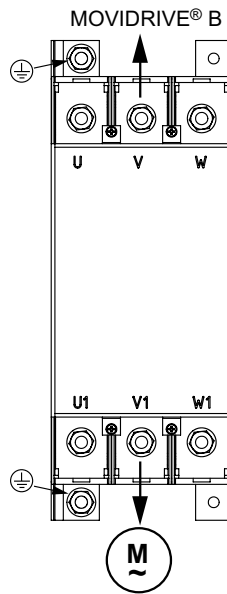
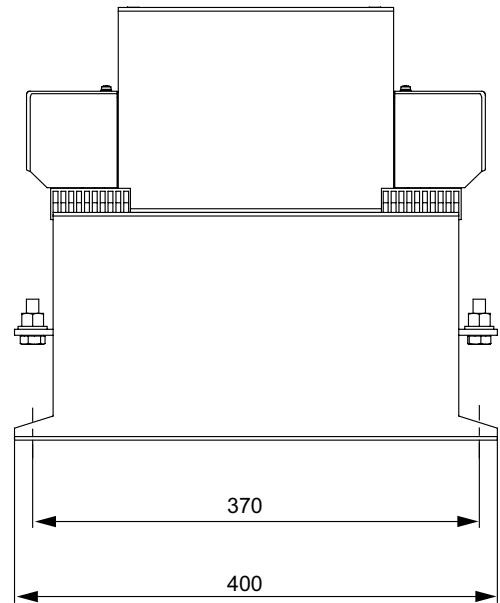
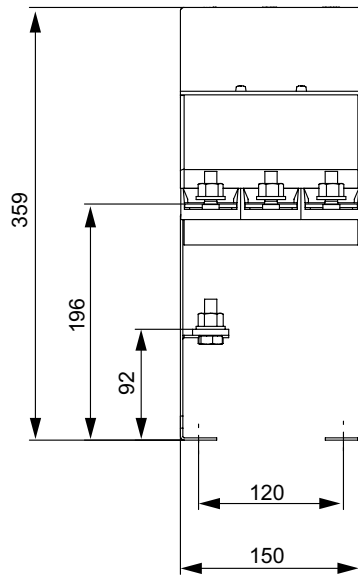
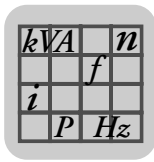

HD004

58424AXX

| Output choke type | Main dimensions mm (in) | | | Mounting dimensions mm (in) | | Inside Ø mm (in) | Hole dimension mm (in) | Weight kg (lb) |
|-------------------|-------------------------|------------|------------|-----------------------------|------------|------------------|------------------------|----------------|
| | A | B | C | a | b | | | |
| HD001 | 121 (4.76) | 64 (2.5) | 131 (5.16) | 80 (3.1) | 50 (2.0) | 50 (2.0) | 5.8 (0.23) | 0.5 (1) |
| HD002 | 66 (2.6) | 49 (1.9) | 73 (2.9) | 44 (1.7) | 38 (1.5) | 23 (0.91) | | 0.2 (0.4) |
| HD003 | 170 (6.69) | 64 (2.5) | 185 (7.28) | 120 (4.72) | 50 (2.0) | 88 (3.5) | 7.0 (0.28) | 1.1 (2.4) |
| HD004 | 150 (5.91) | 400 (15.7) | 360 (14.2) | 120 (4.72) | 370 (14.6) | - | 9.0 (0.35) | 12.5 (27.6) |

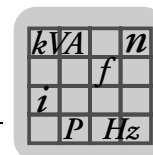

2.47 Output filter option type HF...

HF... output filters are sine filters used to smooth output voltage from inverters. HF... output filters (with the exception of HF450-503) are approved to UL/cUL in combination with MOVIDRIVE® inverters. HF... output filters are used in the following cases:

- In group drives (several motor leads in parallel); the discharge currents in the motor cables are suppressed.
- To protect the motor winding insulation of non-SEW motors which are not suitable for inverters
- for protection against overvoltage spikes in long motor cables (> 100 m)

Please read the following notes carefully:

| NOTES | |
|--------------|--|
| | <ul style="list-style-type: none"> • Operate output filters in V/f and VFC operating modes only. Do not use output filters in CFC and SERVO operating modes. • Do not use output filters in hoist applications. • During project planning of the drive, take into account the voltage drop in the output filter and consequently the reduced motor torque available. This applies particularly to AC 230 V units with output filters. |

| Output filter type | HF008-503 ¹⁾ | HF015-503 ¹⁾ | HF022-503 ¹⁾ | HF030-503 ¹⁾ | HF040-503 ¹⁾ | HF055-503 ¹⁾ |
|--|--|---|-------------------------|-------------------------|-------------------------|-------------------------|
| Part number | 826 029 X | 826 030 3 | 826 031 1 | 826 032 X | 826 311 6 | 826 312 4 |
| Rated voltage V_N | 3 × AC 230 V - 500 V, 50/60 Hz ²⁾ | | | | | |
| Earth-leakage current at $U_N \Delta I$ | 0 mA | | | | | |
| Power loss at $I_N P_V$ | 25 W | 35 W | 55 W | 65 W | 90 W | 115 W |
| Interference emission via unshielded motor cable | According to limit value class C1 to EN 61800-3 | | | | | |
| Ambient temperature ϑ_U | 0 ... +45 °C (reduction: 3 % I_N per K to max. 60 °C) | | | | | |
| Degree of protection (EN 60529) | IP20 | | | | | |
| Connections / tightening torque | M4 terminal stud 1.6 Nm ± 20 % | | | | | |
| Weight | 3.1 kg (6.8 lb) | 4.4 kg (9.7 lb) | | | 10.8 kg (23.8 lb) | |
| Assignment to AC 400/500 V units (MDX60/61B...-5_3) | | | | | | |
| Voltage drop at $I_N \Delta U$ | < 6.5 % (7.5 %) at AC 400 V / < 4 % (5 %) at AC 500 V and $f_{Amax} = 50$ Hz (60 Hz) | | | | | |
| Rated throughput current ³⁾ $I_{N 400 V}$ (at $V_{supply} = 3 \times AC 400 V$) | AC 2.5 A | AC 4 A | AC 6 A | AC 8 A | AC 10 A | AC 12 A |
| Rated throughput current ³⁾ $I_{N 500 V}$ (at $V_{supply} = 3 \times AC 500 V$) | AC 2 A | AC 3 A | AC 5 A | AC 6 A | AC 8 A | AC 10 A |
| Rated operation (100 %) ³⁾ | 0005 ... 0011 | 0014 / 0015 | 0022 | 0030 | 0040 | 0055 |
| Increased power (125 %) ³⁾ | 0005 | 0008 / 0011 | 0014 / 0015 | 0022 | 0030 | 0040 |
| Assignment to 230 V units (MDX61B...-2_3) | | | | | | |
| Voltage drop at $I_N \Delta U$ | - | < 18.5 % (19 %) at AC 230 V with $f_{Amax} = 50$ Hz (60 Hz) | | | | |
| Rated throughput current ³⁾ $I_{N 230 V}$ (at $V_{supply} = 3 \times AC 230 V$) | AC 4.3 A | AC 6.5 A | AC 10.8 A | AC 13 A | AC 17.3 A | AC 22 A |
| Rated operation (100 %) ³⁾ | - | - | 0015/0022 | - | 0037 | 0055 |
| Increased power (125 %) ³⁾ | - | - | 0015/0022 | - | - | 0037 |

1) Approved to UL/cUL in combination with MOVIDRIVE® inverters. SEW-EURODRIVE will provide a certificate on request.

2) A reduction of 6 % I_N per 10 Hz applies above $f_A = 60$ Hz for the rated through current I_N .

3) Only applies to operation without $V_{DC link}$ connection. For operating the inverter with $V_{DC link}$ connection, observe the project planning notes in the system manual of the respective inverter.

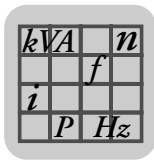

Technical Data and Dimension Sheets

Output filter option type HF...

| Output filter type | HF075-503 ¹⁾ | HF023-403 ¹⁾ | HF033-403 ¹⁾ | HF047-403 ¹⁾ | HF450-503 |
|--|--|--------------------------------------|-------------------------|-------------------------|--|
| Part number | 826 313 2 | 825 784 1 | 825 785 X | 825 786 8 | 826 948 3 |
| Rated voltage V_N | 3 × AC 230 V - 500 V, 50/60 Hz ²⁾ | | | | |
| Earth-leakage current at $U_N \Delta I$ | 0 mA | | | | |
| Power loss at $I_N P_V$ | 135 W | 90 W | 120 W | 200 W | 400 W |
| Interference emission via unshielded motor cable | According to limit value class C1 to EN 61800-3 | | | | |
| Ambient temperature ϑ_U | 0 ... +45 °C (reduction: 3 % I_N per K to max. 60 °C) | | | | |
| Degree of protection (EN 60529) | IP 20 | IP20 | | | IP 10 |
| Connections / tightening torque | M4 terminal stud 1.6 Nm ± 20 % | 35 mm ² (AWG 2) 3.2 Nm | | | |
| Weight | 10.8 kg (23.8 lb) | 15.9 kg (35.1 lb) | 16.5 kg (36.4 lb) | 23 kg (51 lb) | 32 kg (71 lb) |
| Assignment to AC 400/500 V units (MDX60/61B...-5_3) | | | | | |
| Voltage drop at $I_N \Delta U$ | < 6.5 % (7.5 %) at AC 400 V / < 4 % (5 %) at AC 500 V and $f_{Amax} = 50$ Hz (60 Hz) | | | | |
| Rated throughput current ³⁾ $I_{N 400 V}$ (at $V_{supply} = 3 \times AC 400 V$) | AC 16 A | AC 23 A | AC 33 A | AC 47 A | AC 90 A |
| Rated throughput current ³⁾ $I_{N 500 V}$ (at $V_{supply} = 3 \times AC 500 V$) | AC 13 A | AC 19 A | AC 26 A | AC 38 A | AC 72 A |
| Rated operation (100 %) ³⁾ | 0075 | 0110 | 0150/0300 ⁴⁾ | 0220 | 0370/0450/ 0550 ⁴⁾ /0750 ⁴⁾ / 0900 ⁴⁾ |
| Increased power (125 %) ³⁾ | 0055 | 0075 | 0110/0220 ⁴⁾ | 0150 | 0300/0370/0450 ⁴⁾ / /0550 ⁴⁾ /0750 ⁴⁾ |
| Assignment to 230 V units (MDX61B...-2_3) | | | | | |
| Voltage drop at $I_N \Delta U$ | < 18.5 % (19 %) at AC 230 V with $f_{Amax} = 50$ Hz (60 Hz) | | | | |
| Rated throughput current ³⁾ $I_{N 230 V}$ (at $V_{supply} = 3 \times AC 230 V$) | AC 29 A | AC 42 A | AC 56.5 A | AC 82.6 A | AC 156 A |
| Rated operation (100 %) ³⁾ | 0075 | 0110 | 0150/0300 ⁴⁾ | 0220 | 0300 |
| Increased power (125 %) ³⁾ | 0055 | 0075 | 0110/0220 ⁴⁾ | 0150 | 0220/0300 |

- 1) Approved to UL/cUL in combination with MOVIDRIVE[®] inverters. SEW-EURODRIVE will provide a certificate on request.
- 2) A reduction of 6 % I_N per 10 Hz applies above $f_A = 60$ Hz for the rated through current I_N .
- 3) Only applies for operation without $V_{DC link}$ connection. For operation with V_Z connection, observe the project planning instructions in the MOVIDRIVE[®] MDX60/61B system manual, section "Project Planning/Connecting the optional power components."
- 4) Connect **two HF... output filters together in parallel** for operation with these MOVIDRIVE[®] units.

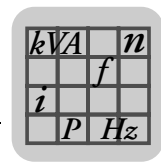

Dimension drawings for HF...-503 output filters

HF008 / 015 / 022 / 030-503

HF040/055/075-503

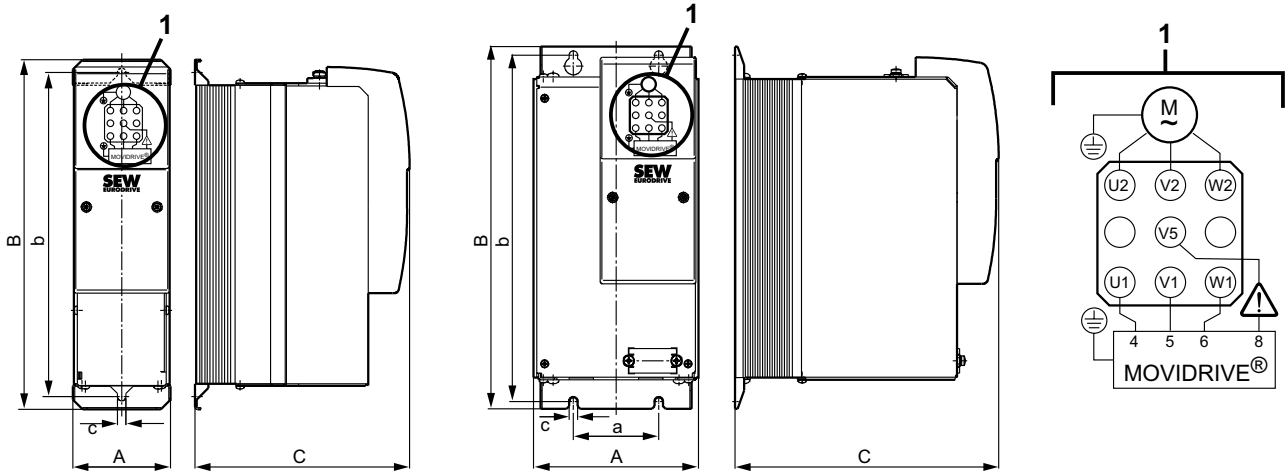

58418AXX

Figure 31: Dimension drawings for output filters HF008...075-503

Only the mounting position shown in the dimension drawing is permitted.

| Output filter type | Main dimensions mm (in) | | | Mounting dimensions mm (in) | | Hole dimension mm (in) | Ventilation clearances ¹⁾ mm (in) | |
|-----------------------|-------------------------|------------|------------|-----------------------------|------------|------------------------|--|------------|
| | A | B | C | a | b | | Top | Bottom |
| HF008/015/022/030-503 | 80 (3.1) | 286 (11.3) | 176 (6.93) | - | 265 (10.4) | 7 (0.3) | 100 (3.94) | 100 (3.94) |
| HF040/055/075-503 | 135 (5.31) | 296 (11.7) | 216 (8.5) | 70 (2.8) | 283 (11.1) | | | |

1) There is no need for clearance at the sides. You can line up the units next to one another.

HF450-503

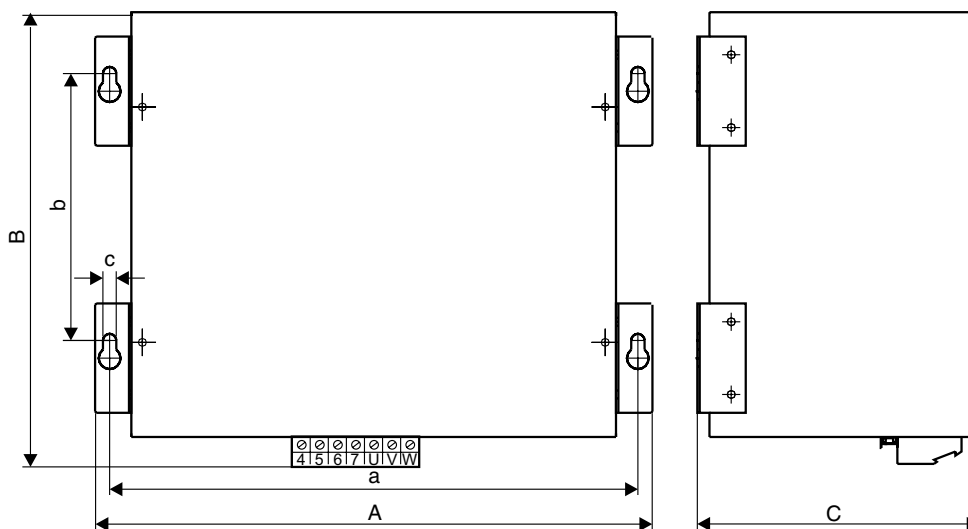

58417AXX

Figure 32: Dimension drawing for output filter HF450-503

Only the mounting position shown in the dimension drawing is permitted

| Output filter type | Main dimensions mm (in) | | | Mounting dimensions mm (in) | | Hole dimension mm (in) | Ventilation clearances mm (in) | |
|--------------------|-------------------------|------------|------------|-----------------------------|------------|------------------------|--------------------------------|------------|
| | A | B | C | a | b | | Top | Bottom |
| HF450-503 | 465 (18.3) | 385 (15.2) | 240 (9.45) | 436 (17.2) | 220 (8.66) | 8.5 (0.33) | 100 (3.94) | 100 (3.94) |

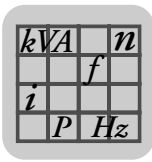

Dimension drawing for HF...-403 output filter

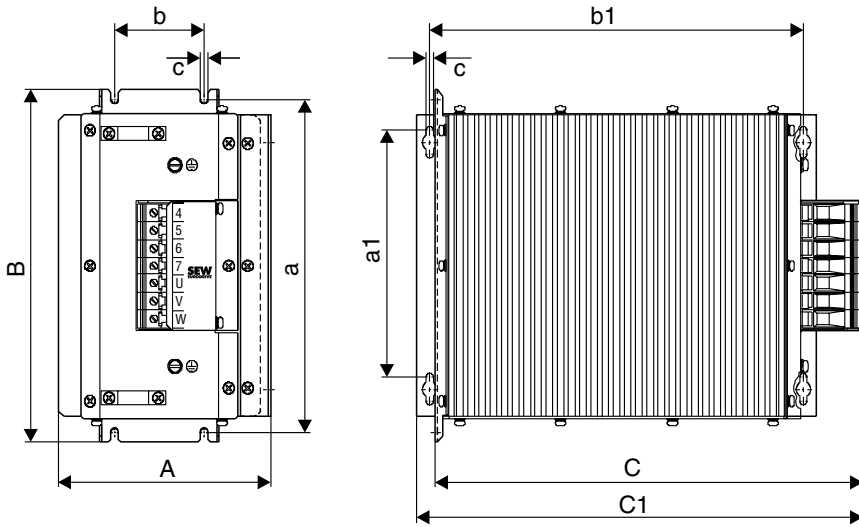

58996AXX

Figure 33: Dimension drawing for HF...-403 output filter

| Type | Main dimensions mm (in) | | | Mounting dimensions mm (in) | | | | Hole dimension mm (in) | Ventilation clearances mm (in) | | |
|-----------|-------------------------|---------------|------------------------|-----------------------------|----------|------------------------------|---------------|------------------------|--------------------------------|---------------|---------------|
| | | | | Standard mounting position | | Horizontal mounting position | | | At the side | Top | Bottom |
| | A | B | C/C1 | a | b | a1 | a2 | c | | | |
| HF023-403 | 145 (5.71) | 284 (11.2) | 365/390 (14.4/15.4) | 268 (10.6) | 60 (2.4) | 210 (8.27) | 334 (13.1) | 6.5 (0.26) | je 30 (1.2) | 150 (5.91) | 150 (5.91) |
| HF033-403 | | | | | | | | | | | |
| HF047-403 | 190 (7.48) | 300 (11.8) | 385/400 (15.2/15.7) | 284 (11.2) | 80 (3.1) | | | | | | |

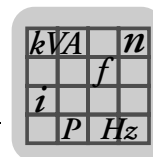

2.48 Prefabricated cables

Overview

SEW offers cable sets and prefabricated cables for straightforward and error-free connection of various system components to MOVIDRIVE®. The cables are prefabricated in 1 m steps to the required length. It is necessary to differentiate between whether the cables are intended for fixed routing or for cable carrier applications.

1. Cable sets for DC link connection MDR → MDX
2. Motor cables and extension cables for connecting CM motors
3. Motor cables and extension cables for connecting DS, CMD and CMP motors.
4. VR forced cooling fan cable and extension cable
5. Connection to DEH11B/DEH21B/DER11B: Encoder cable and extensions cable (Hiperface®, incremental encoder), resolver cable and extension cable in plug and terminal box design for motors.

1. Cable sets for DC link connection MDR → MDX

Description

SEW-EURODRIVE strongly recommends using the cable sets listed in the table below. These cable sets offer the appropriate dielectric strength and are also color-coded. Color coding is necessary because cross-polarity and ground faults could cause irreparable damage to the connected equipment.

The length of the cables restricts the DC link connection to the permitted length of 5 m. They can also be cut to length by the customer for connecting several units. The lugs for connection to the regenerative power supply unit and an inverter are supplied with the cable set. Use commercially available cable lugs to connect other inverters. In this case, connect inverters in star configuration to the regenerative power supply unit. Use a busbar subdistributor if the DC link terminals of the regenerative power supply unit are not sufficient.

Installation type

Only fixed routing is possible.

| Cable set type | DCP12A | DCP13A | DCP15A | DCP16A |
|---------------------------|-------------|-------------|-------------|-------------|
| Part number | 814 567 9 | 814 250 5 | 814 251 3 | 817 593 4 |
| For connecting MOVIDRIVE® | 0015...0110 | 0150...0370 | 0450...0750 | 0900...1320 |

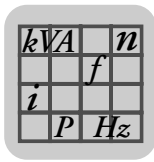

2. Prefabricated cables and extension cables for connecting CM motors to MDX

Motor cables

The cables are equipped with a connector for motor connection and conductor end sleeves for inverter connection.

| Number of cores and line cross section | Part number | Installation type | for motor |
|---|-------------|--------------------|-------------|
| 4×1.5 mm ² | 199 179 5 | Fixed installation | CM..SM51 |
| 4×1.5 mm ² + 3×1.0 mm ² | 199 189 2 | | CM..BR SB51 |
| 4×2.5 mm ² | 199 181 7 | | CM..SM52 |
| 4×2.5 mm ² + 3×1.0 mm ² | 199 191 4 | | CM..BR SB52 |
| 4×4 mm ² | 199 183 3 | | CM..SM54 |
| 4×4 mm ² + 3×1.0 mm ² | 199 193 0 | | CM..BR SB54 |
| 4×6 mm ² | 199 185 X | | CM..SM56 |
| 4×6 mm ² + 3×1.5 mm ² | 199 195 7 | | CM..BR SB56 |
| 4×10 mm ² | 199 187 6 | | CM..SM59 |
| 4×10 mm ² + 3×1.5 mm ² | 199 197 3 | | CM..BR SB59 |

| Number of cores and line cross section | Part number | Installation type | for motor |
|---|-------------|----------------------------|-------------|
| 4×1.5 mm ² | 1 333 114 0 | Cable carrier installation | CM..SM51 |
| 4×1.5 mm ² + 3×1.0 mm ² | 1 333 116 7 | | CM..BR SB51 |
| 4×2.5 mm ² | 1 333 115 9 | | CM..SM52 |
| 4×2.5 mm ² + 3×1.0 mm ² | 1 333 117 5 | | CM..BR SB52 |
| 4×4 mm ² | 199 184 1 | | CM..SM54 |
| 4×4 mm ² + 3×1.0 mm ² | 199 194 9 | | CM..BR SB54 |
| 4×6 mm ² | 199 186 8 | | CM..SM56 |
| 4×6 mm ² + 3×1.5 mm ² | 199 196 5 | | CM..BR SB56 |
| 4×10 mm ² | 199 188 4 | | CM..SM59 |
| 4×10 mm ² + 3×1.5 mm ² | 199 198 1 | | CM..BR SB59 |

Extension cables

The cables are equipped with a connector and adapter for extending the CM motor cable.

| Number of cores and line cross section | Part number | Installation type | for motor |
|---|-------------|--------------------|-------------|
| 4×1.5 mm ² | 199 549 9 | Fixed installation | CM..SM51 |
| 4×1.5 mm ² + 3×1.0 mm ² | 199 199 X | | CM..BR SB51 |
| 4×2.5 mm ² | 199 551 0 | | CM..SM52 |
| 4×2.5 mm ² + 3×1.0 mm ² | 199 201 5 | | CM..BR SB52 |
| 4×4 mm ² | 199 553 7 | | CM..SM54 |
| 4×4 mm ² + 3×1.0 mm ² | 199 203 1 | | CM..BR SB54 |
| 4×6 mm ² | 199 555 3 | | CM..SM56 |
| 4×6 mm ² + 3×1.5 mm ² | 199 205 8 | | CM..BR SB56 |
| 4×10 mm ² | 199 557 X | | CM..SM59 |
| 4×10 mm ² + 3×1.5 mm ² | 199 207 4 | | CM..BR SB59 |

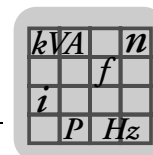

| Number of cores and line cross section | Part number | Installation type | for motor |
|---|-------------|----------------------------|-------------|
| 4×1.5 mm ² | 1 333 118 3 | Cable carrier installation | CM..SM51 |
| 4×1.5 mm ² + 3×1.0 mm ² | 1 333 120 5 | | CM..BR SB51 |
| 4×2.5 mm ² | 1 333 119 1 | | CM..SM52 |
| 4×2.5 mm ² + 3×1.0 mm ² | 1 333 121 3 | | CM..BR SB52 |
| 4×4 mm ² | 199 554 5 | | CM..SM54 |
| 4×4 mm ² + 3×1.0 mm ² | 199 204 X | | CM..BR SB54 |
| 4×6 mm ² | 199 556 1 | | CM..SM56 |
| 4×6 mm ² + 3×1.5 mm ² | 199 206 6 | | CM..BR SB56 |
| 4×10 mm ² | 199 558 8 | | CM..SM59 |
| 4×10 mm ² + 3×1.5 mm ² | 199 208 2 | | CM..BR SB59 |

3. Prefabricated cables and extension cables for connecting DS/CMD/CMP motors

Motor cables The cables are equipped with a connector for motor connection and conductor end sleeves for inverter connection.

| Number of cores and line cross section | Part number | Installation type | for motor |
|---|-------------|--------------------|----------------------------------|
| 4×1.5 mm ² | 590 454 4 | Fixed installation | DS56 / CMD.. / CMP.. SM11 |
| 4×1.5 mm ² + 2×1 mm ² | 1 332 485 3 | | DS56..B / CMD..BP / CMP..BP SB11 |
| 4×2.5 mm ² | 590 455 2 | | DS56 / CMD.. / CMP.. SM12 |
| 4×2.5 mm ² + 2×1 mm ² | 1 333 213 9 | | DS56..B / CMD..BP / CMP..BP SB12 |
| 4×4 mm ² | 590 456 0 | | DS56 / CMD.. / CMP.. SM14 |
| 4×4 mm ² + 2×1 mm ² | 1 333 214 7 | | DS56..B / CMD..BP / CMP..BP SB14 |

| Number of cores and line cross section | Part number | Installation type | for motor |
|---|-------------|----------------------------|----------------------------------|
| 4×1.5 mm ² | 590 624 5 | Cable carrier installation | DS56 / CMD.. / CMP.. SM11 |
| 4×1.5 mm ² + 2×1 mm ² | 1 333 122 1 | | DS56..B / CMD..BP / CMP..BP SB11 |
| 4×2.5 mm ² | 590 625 3 | | DS56 / CMD.. / CMP.. SM12 |
| 4×2.5 mm ² + 2×1 mm ² | 1 333 215 5 | | DS56..B / CMD..BP / CMP..BP SB12 |
| 4×4 mm ² | 590 480 3 | | DS56 / CMD.. / CMP.. SM14 |
| 4×4 mm ² + 2×1 mm ² | 1 333 216 3 | | DS56..B / CMD..BP / CMP..BP SB14 |

Extension cables The cables are equipped with a connector and adapter for extending the motor cable.

| Number of cores and line cross section | Part number | Installation type | for motor |
|---|-------------|----------------------------|----------------------------------|
| 4×1.5 mm ² | 1 333 245 7 | Cable carrier installation | DS56 / CMD.. / CMP.. SM11 |
| 4×1.5 mm ² + 2×1 mm ² | 1 333 248 1 | | DS56..B / CMD..BP / CMP..BP SB11 |
| 4×2.5 mm ² | 1 333 246 5 | | DS56 / CMD.. / CMP.. SM12 |
| 4×2.5 mm ² + 2×1 mm ² | 1 333 250 3 | | DS56..B / CMD..BP / CMP..BP SB12 |
| 4×4 mm ² | 1 333 247 3 | | DS56 / CMD.. / CMP.. SM14 |
| 4×4 mm ² + 2×1 mm ² | 1 333 251 1 | | DS56..B / CMD..BP / CMP..BP SB14 |

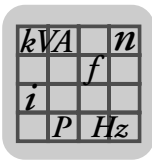

4. Prefabricated cables and extension cables for connecting VR forced cooling fans

VR forced cooling fan cable:

| Number of cores and line cross section | Part number | Installation type |
|--|-------------|----------------------------|
| 3×1 mm ² | 198 634 1 | Fixed installation |
| 3×1 mm ² | 199 560 X | Cable carrier installation |

Extension cable for the VR forced cooling fan cable:

| Number of cores and line cross section | Part number | Installation type |
|--|-------------|----------------------------|
| 3×1 mm ² | 199 561 8 | Fixed installation |
| 3×1 mm ² | 199 562 6 | Cable carrier installation |

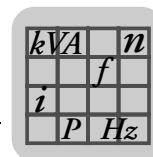

5. Prefabricated cables for connecting options DEH11B / DEH21B / DER11B

The following overviews show the possible connections for the DEH11B/DEH21B and DER11B options.

2

Meaning of the symbols

The connection cables are assigned a part number and a symbol. The symbols have the following meaning:

| Symbol | Meaning |
|--------------|--|
| 56047AXX | Connection cable connector → connector for fixed installation |
| 56051AXX | Extension connection cable connector → connector for fixed installation |
| 56048AXX | Connection cable connector → connector for cable carrier installation |
| 56052AXX | Extension connection cable connector → connector for cable carrier installation |
| 56049AXX | Connection cable connector → terminal box for fixed installation |
| 56050AXX | Connection cable connector → terminal box for cable carrier installation |
| 56053AXX | Connection cable connector → Y connector for fixed installation |
| 56054AXX | Connection cable connector → Y connector for cable carrier installation |
| 56489AXX | Connection cable connector → connector with crossed A/B track for reversing the direction of rotation (for fixed installation) |
| 56112AXX | Encoder connection via plug connector |
| 56113AXX | Encoder connection via encoder terminal strip |
| 56114AXX | Connection via plug connector on the motor side |
| 56115AXX | Connection via terminal box on the motor side |

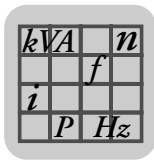

Connection options at X15 X15 DEH11B/DEH21B

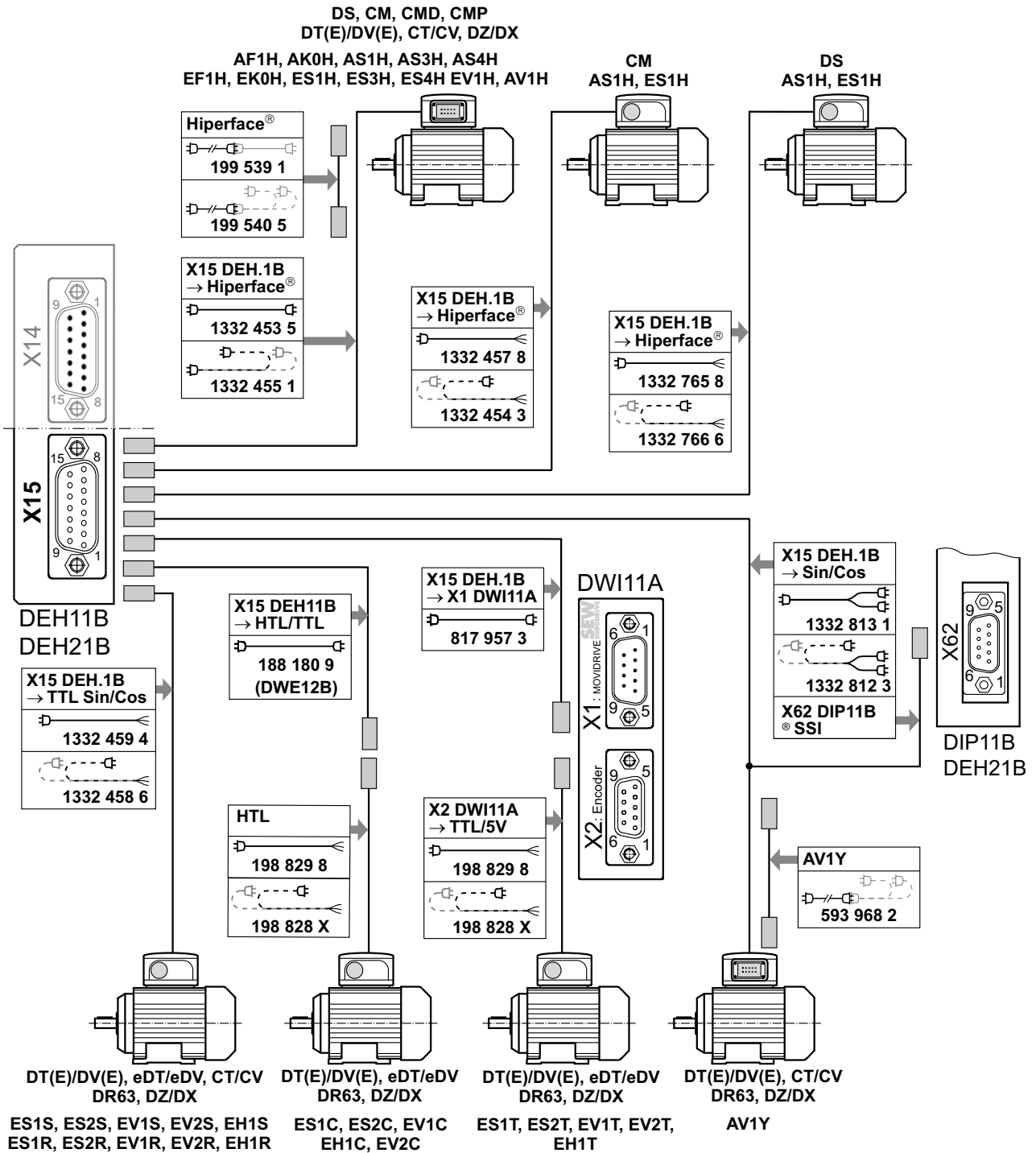

62907AXX



NOTE

For the individual wiring diagrams, refer to the section "Installation" in the MOVIDRIVE® MDX60B/61B" operating instructions.

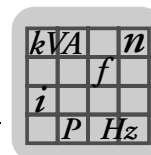

- Cable to connect HIPERFACE® encoders AF1H, AK0H, AS1H, AS3H, AS4H, EF1H, EK0H, ES1H, ES3H, ES4H, EV1H, AV1H with plug connector connection on the motor side to DS, CM, CMD, CMP, DT, DV, DT(E), DV(E), CT, CV, DZ or DX motors.

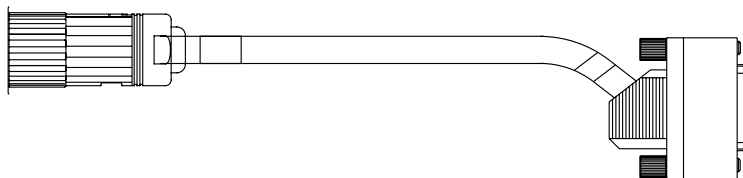

56135AXX

| Type | Installation | Part number |
|---|--------------|-------------|
| DEH11B/21B X15 → DS/CM/CMD/CMP/DT/DV/DT(E)/DV(E)/CT/CV/DZ/ DX motors with AF1H, AK0H, AS1H, AS3H, AS4H, EF1H, EK0H, ES1H, ES3H, ES4H, EV1H, AV1H | 56047AXX | 1332 453 5 |
| | 56048AXX | 1332 455 1 |

- Extension cable to connect HIPERFACE® encoders AF1H, AK0H, AS1H, AS3H, AS4H, EF1H, EK0H, ES1H, ES3H, ES4H, EV1H, AV1H with plug connector connection on the motor side to DS, CM, CMD, CMP, DT, DV, DT(E), DV(E), CT, CV, DZ or DX motors.

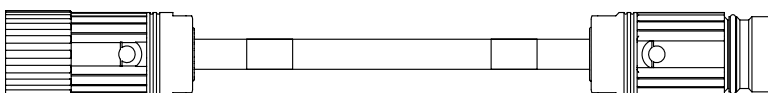

56136AXX

| Type | Installation | Part number |
|---|--------------|-------------|
| DEH11B/21B X15 → DS/CM/CMD/CMP/DT/DV/DT(E)/DV(E)/CT/CV/DZ/ DX motors with AF1H, AK0H, AS1H, AS3H, AS4H, EF1H, EK0H, ES1H, ES3H, ES4H, EV1H, AV1H | 56051AXX | 199 539 1 |
| | 56052AXX | 199 540 5 |

- Cable to connect HIPERFACE® encoders AS1H, ES1H, AF1H, EF1H with terminal box connection on the motor side to CM motors.

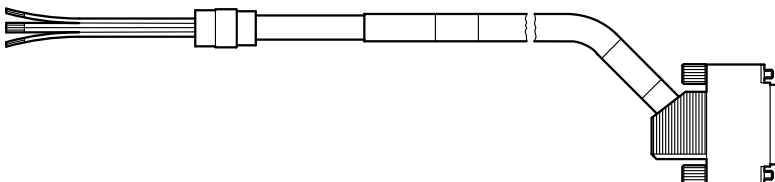

56137AXX

| Type | Installation | Part number |
|---|--------------|-------------|
| DEH11B/21B X15 → CM motors with AS1H, ES1H, AF1H, EF1H | 56049AXX | 1332 457 8 |
| | 56050AXX | 1332 454 3 |

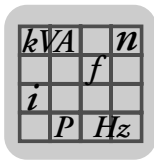

- Cable to connect HIPERFACE® encoders AS1H, ES1H, AF1H, EF1H with terminal box connection on the motor side to DS motors.

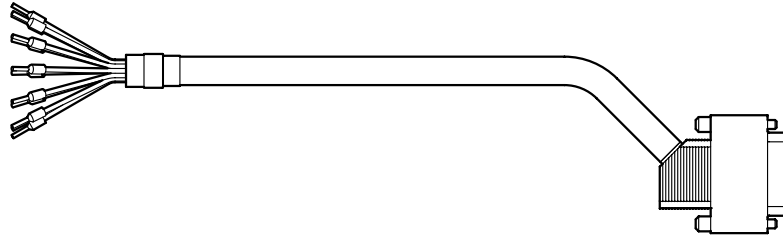

56132AXX

| Type | Installation | Part number |
|--|--------------|-------------|
| DEH11B/21B X15 → DS motors with AS1H, ES1H, AF1H, EF1H | 56049AXX | 1332 765 8 |
| | 56050AXX | 1332 766 6 |

- Cable to connect sin/cos encoders ES1S, ES2S, EV1S, EV2S, EH1S, ES1R, ES2R, EV1R, EV2R, EH1R with terminal box connection on the motor side to CT, CV, DT(E), DV(E), eDT, eDV, DR, DZ and DX motors.

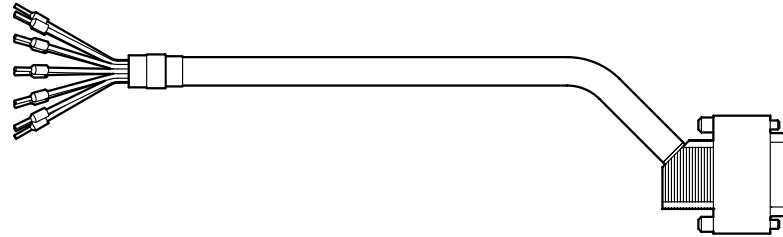

56132AXX

| Type | Installation | Part number |
|--|--------------|-------------|
| DEH11B/21B X15 → DT(E)/DV(E)/eDT/eDV/CT/CV/DR/DZ/DX motors with sin/cos encoders ES1S, ES2S, EV1S, EV2S, EH1S, ES1R, ES2R, EV1R, EV2R, EH1R | 56049AXX | 1332 459 4 |
| | 56050AXX | 1332 458 6 |

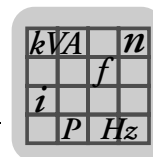

- Cable (option DWE12B, interface adapter HTL → TTL) to connect push-pull HTL encoders at X15 of option (→ chapter "Interface adapter DWE11B/12B").

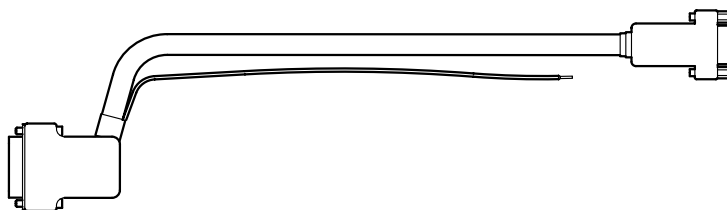

59109AXX

| Type | Installation | Part number |
|--|--------------|-------------|
| DEH11B/21B X15 → Option DWE12B (connection for push-pull HTL encoders) | 56047AXX | 188 180 9 |

- Cable to connect push-pull HTL encoders ES1C, ES2C, EV1C, EV2C, EH1C with terminal box connection on the motor side to DT(E), DV(E), eDT, eDV, DR, DZ and DX motors.



56132AXX

| Type | Installation | Part number |
|---|--------------|-------------|
| Push-pull HTL encoders ES1C, ES2C, EV1C, EV2C, EH1C → DT(E)/DV(E)/eDT/eDV/DR/DZ/DX motors | 56049AXX | 198 829 8 |
| | 56050AXX | 198 828 X |

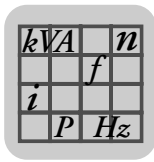

- Cable to connect DC 5 V TTL sensors ES1T, ES2T, EV1T, EV2T, EH1T with terminal box connection on the motor side (DT(E), DV(E), eDT, eDV, DR, DZ or DX motors) to DC 5 V encoder power supply type DWI11A.

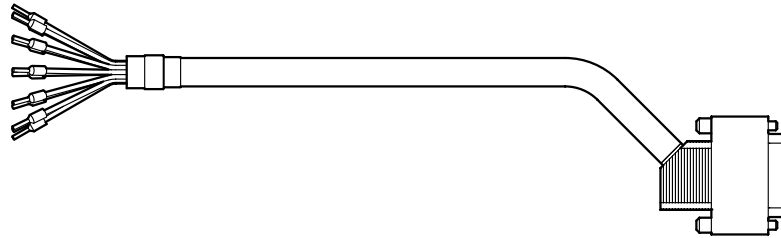

56132AXX

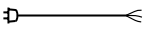
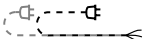
| Type | Installation | Part number |
|---|--|-------------|
| DC 5 V TTL sensors ES1T, ES2T, EV1T, EV2T, EH1T → DWI11A X2 |  56049AXX | 198 829 8 |
| |  56050AXX | 198 828 X |

- Cable to connect the DC 5 V encoder power supply type DWI11A via plug connector.

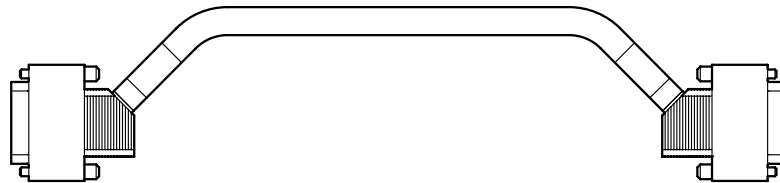

56109AXX

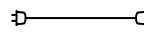
| Type | Installation | Part number |
|----------------------------|--|-------------|
| DEH11B/21B X15 → DWI11A X1 |  56047AXX | 817 957 3 |

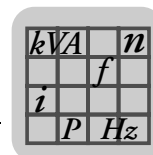

- Y cable to connect the AV1Y absolute encoder with plug connector on the motor side to DT(E), DV(E), CT, CV, DR, DZ and DX motors. The following encoder tracks are evaluated with the Y cable:
 - SSI track of the AV1Y absolute encoder and at DIP11B/DEH21B X62
 - sin/cos track of the AV1Y absolute encoder at DEH11B X15

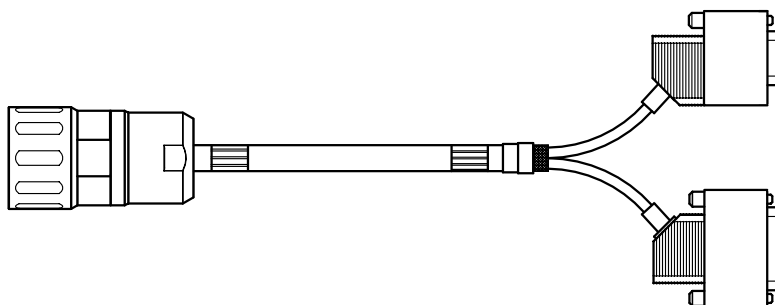

59321AXX

| Type | Installation | Part number |
|---|--------------|-------------|
| DEH11B X15 → AV1Y and DIP11B/DEH21B X62 | 56053AXX | 1332 813 1 |
| | 56054AXX | 1332 812 3 |

- Extension cable to connect the AV1Y absolute encoder with plug connector on the motor side to DT(E), DV(E), CT, CV, DR, DZ und DX motors.

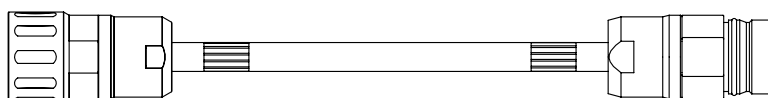

56131AXX

| Type | Installation | Part number |
|--|--------------|-------------|
| DT(E)/DV(E)/CT/CV/DR/DZ/DX motors → AV1Y | 56052AXX | 593 968 2 |

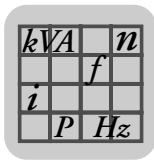

Connection options at X14, DEH11B / DER11B

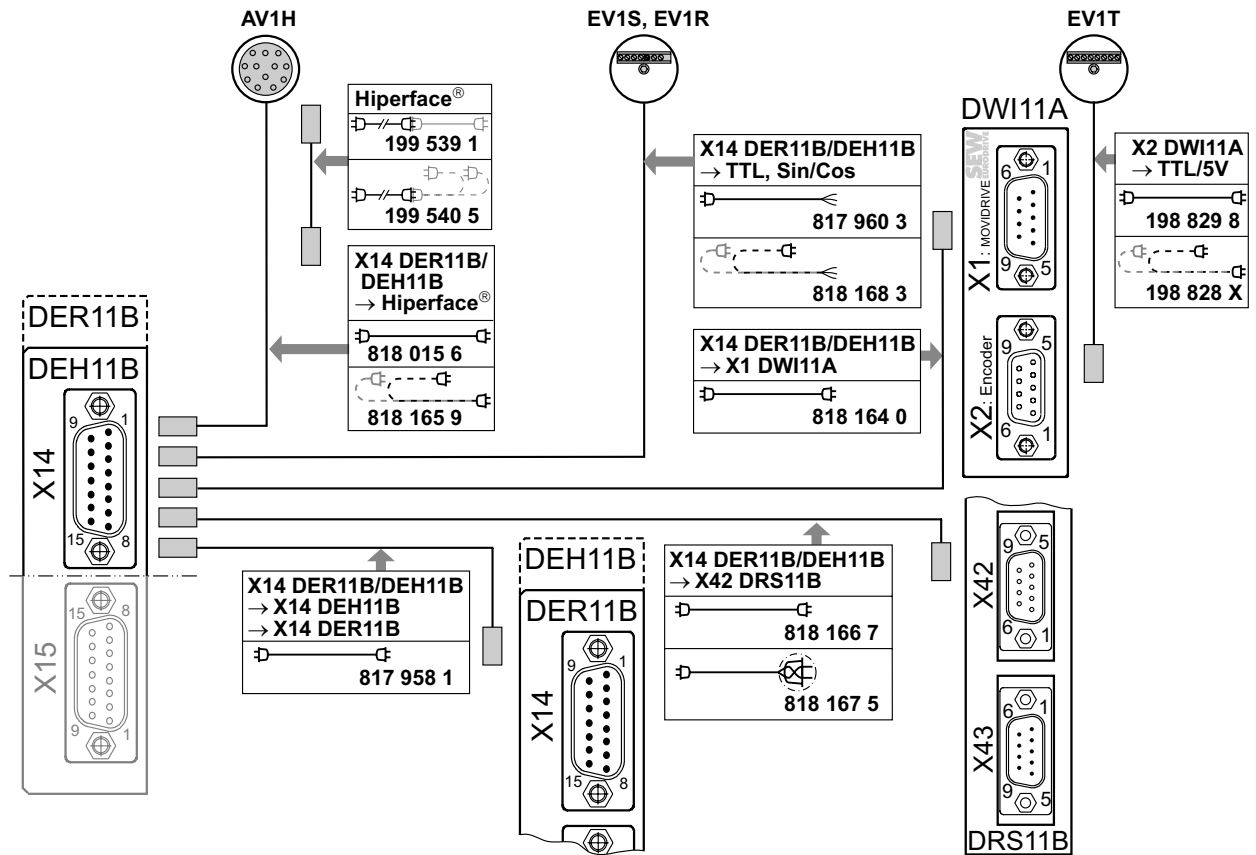

63294AXX

| | |
|--|---|
| | <p>NOTE</p> <p>For the individual wiring diagrams, refer to the section "Installation" in the MOVIDRIVE® MDX60B/61B" operating instructions.</p> |
|--|---|

- Cable to connect external HIPERFACE® encoders AV1H, AS1H, ES1H, AF1H, EF1H via plug connector.

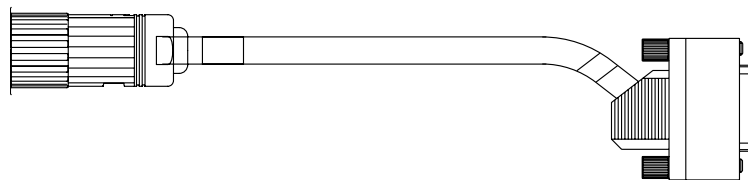

56130AXX

| Type | Installation | Part number |
|--|--------------|-------------|
| DEH11B / DER11B X14 → AV1H, AS1H, ES1H, AF1H, EF1H | 56047AXX | 818 015 6 |
| | 56048AXX | 818 165 9 |

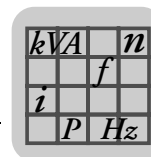

- Cable to connect external HIPERFACE® encoders AV1H, AS1H, ES1H, AF1H, EF1H via plug connector.



56131AXX

| Type | Installation | Part number |
|--|--------------|-------------|
| DEH11B / DER11B X14 → AV1H, AS1H, ES1H, AF1H, EF1H | 56051AXX | 199 539 1 |
| | 56052AXX | 199 540 5 |

2

- Cable to connect external Hiperface® encoders via encoder terminal strip.



56132AXX

| Type | Installation | Part number |
|---|--------------|-------------|
| DEH11B / DER11B X14 → Hiperface® encoders | 56049AXX | 1810 695 1 |
| | 56050AXX | 1810 697 8 |

- Cable to connect external sin/cos encoders via encoder terminal strip.

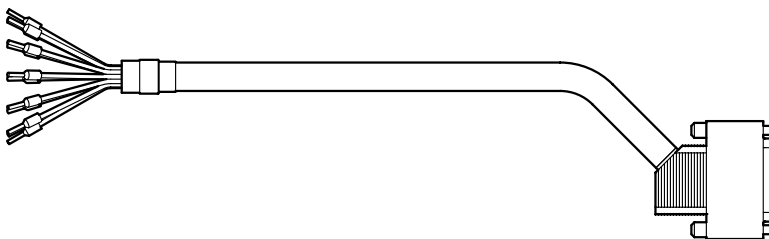

56132AXX

| Type | Installation | Part number |
|--|--------------|-------------|
| DEH11B / DER11B X14 → sin/cos encoders | 56049AXX | 819 869 1 |
| | 56050AXX | 818 168 3 |

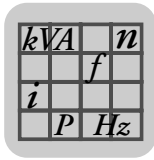

- Cable to connect the DC 5 V encoder power supply type DWI11A via plug connector.

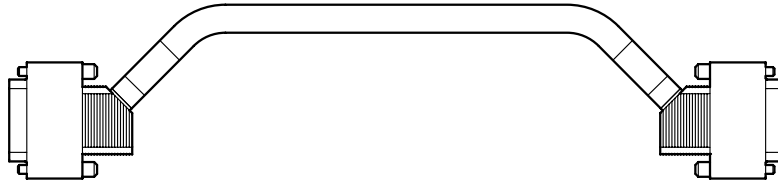

56109AXX

| Type | Installation | Part number |
|---------------------------------|--------------|-------------|
| DEH11B / DER11B X14 → DWI11A X1 | 56047AXX | 818 164 0 |

- Cable to connect an external DC 5 V TTL sensor to the DC 5 V encoder power supply type DWI11A via encoder terminal strip.

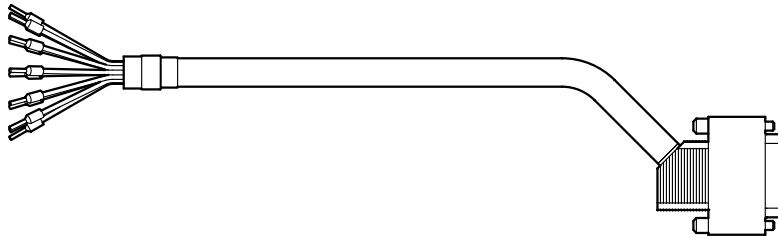

56132AXX

| Type | Installation | Part number |
|-------------------------------|--------------|-------------|
| DC 5 V TTL sensor → DWI11A X2 | 56049AXX | 198 829 8 |
| | 56050AXX | 198 828 X |

- Cable to connect a master/slave connection.

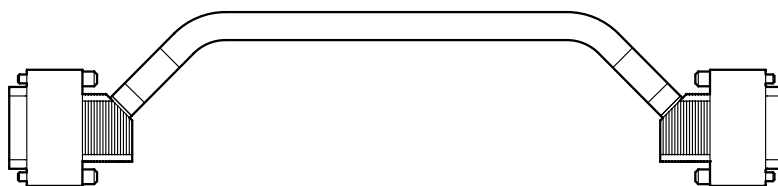

56109AXX

| Type | Installation | Part number |
|---------------------------------------|--------------|-------------|
| DEH11B/DER11B X14 → DER11B/DEH11B X14 | 56047AXX | 817 958 1 |

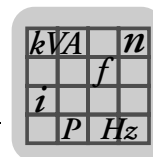

- Cable to connect the encoder simulation (DEH11B/DER11B:X14) of the master to terminal X42 of option DRS11B.

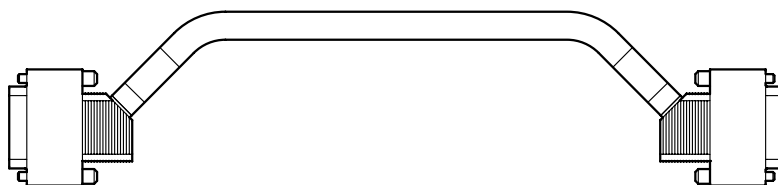

56109AXX

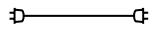
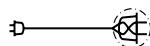
| Type | Installation | Part number |
|--|--|-------------|
| DEH11B/DER11B X14 → DRS11B X42 (master and slave turn in the same direction) |  56047AXX | 0818 166 7 |
| DEH11B/DER11B X14 → DRS11B X42 (master and slave turn in opposite directions) |  56489AXX | 0818 167 5 |

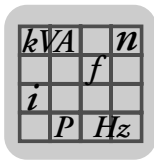

Connection options at X15 DER11B

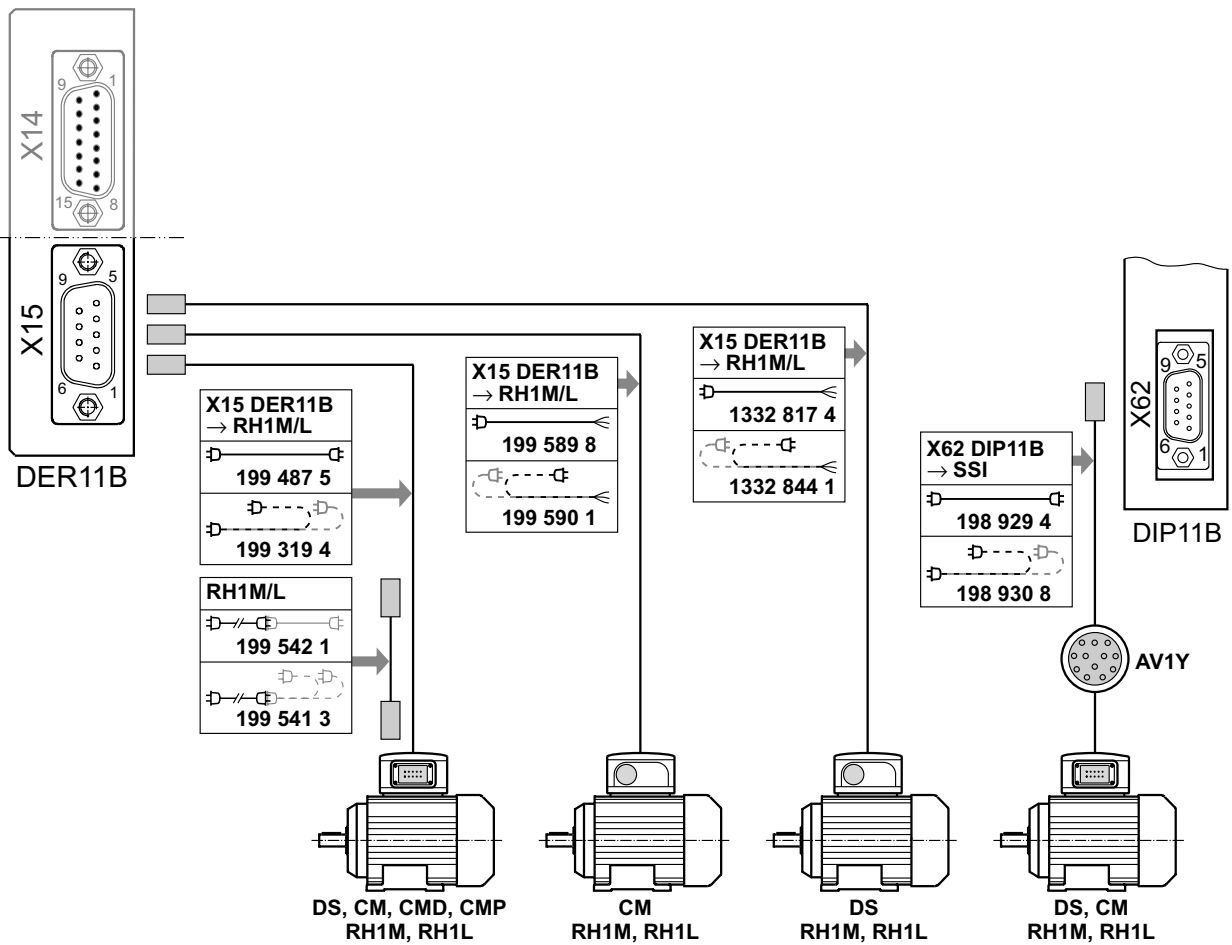

56483BXX



NOTE

For the individual wiring diagrams, refer to the section "Installation" in the MOVIDRIVE® MDX60B/61B" operating instructions.

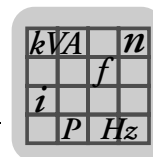

- Cable to connect resolvers RH1M / RH1L with plug connector connection on the motor side to DS, CM, CMD or CMP motors.

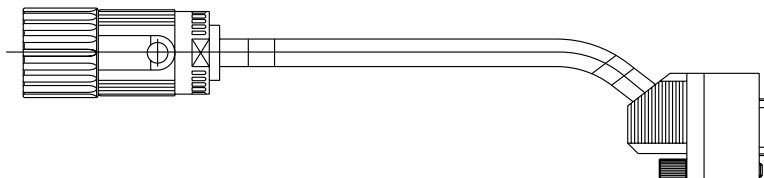

56138AXX

| Type | Installation | Part number |
|--|--------------|-------------|
| DER11B X15 → DS/CM/CMD/CMP motors with RH1M/RH1L | 56047AXX | 199 487 5 |
| | 56048AXX | 199 319 4 |

- Extension cable to connect resolvers RH1M / RH1L with plug connector connection on the motor side to DS, CM, CMD or CMP motors.

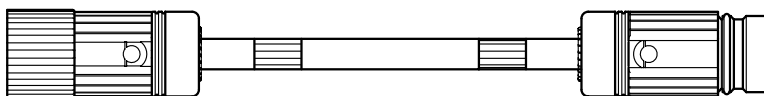

56139AXX

| Type | Installation | Part number |
|--|--------------|-------------|
| DER11B X15 → DS/CM/CMD/CMP motors with RH1M/RH1L | 56051AXX | 199 542 1 |
| | 56052AXX | 199 541 3 |

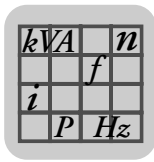

- Cable to connect resolvers RH1M / RH1L with terminal box connection on the motor side to CM and DS motors.

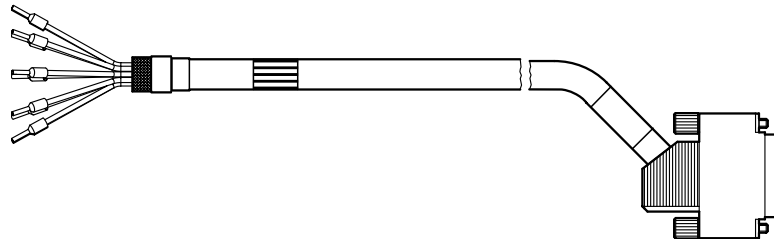

56142AXX

| Type | Installation | Part number |
|---------------------------------------|--------------|-------------|
| DER11B X15 → CM motors with RH1M/RH1L | 56049AXX | 199 589 8 |
| | 56050AXX | 199 590 1 |
| DER11B X15 → DS motors with RH1M/RH1L | 56049AXX | 1332 817 4 |
| | 56050AXX | 1332 844 1 |

- CM and DS motors with integrated resolver: Additional cable to connect the AV1Y absolute encoder with plug connector connection on the motor side to DIP11B X62.

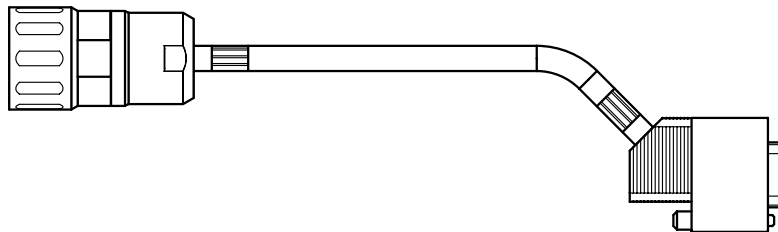

56143AXX

| Type | Installation | Part number |
|-------------------------------------|--------------|-------------|
| DS/CM motors with AV1Y → DIP11B X62 | 56047AXX | 198 929 4 |
| | 56048AXX | 198 930 8 |