

EX3200 Switch Hardware Guide

Published
2020-12-15

Juniper Networks, Inc.
1133 Innovation Way
Sunnyvale, California 94089
USA
408-745-2000
www.juniper.net

Juniper Networks, the Juniper Networks logo, Juniper, and Junos are registered trademarks of Juniper Networks, Inc. in the United States and other countries. All other trademarks, service marks, registered marks, or registered service marks are the property of their respective owners.

Juniper Networks assumes no responsibility for any inaccuracies in this document. Juniper Networks reserves the right to change, modify, transfer, or otherwise revise this publication without notice.

EX3200 Switch Hardware Guide

Copyright © 2020 Juniper Networks, Inc. All rights reserved.

The information in this document is current as of the date on the title page.

YEAR 2000 NOTICE

Juniper Networks hardware and software products are Year 2000 compliant. Junos OS has no known time-related limitations through the year 2038. However, the NTP application is known to have some difficulty in the year 2036.

END USER LICENSE AGREEMENT

The Juniper Networks product that is the subject of this technical documentation consists of (or is intended for use with) Juniper Networks software. Use of such software is subject to the terms and conditions of the End User License Agreement (“EULA”) posted at <https://support.juniper.net/support/eula/>. By downloading, installing or using such software, you agree to the terms and conditions of that EULA.

Table of Contents

About the Documentation | xi

Documentation and Release Notes | xi

Using the Examples in This Manual | xi

 Merging a Full Example | xii

 Merging a Snippet | xiii

Documentation Conventions | xiii

Documentation Feedback | xvi

Requesting Technical Support | xvi

 Self-Help Online Tools and Resources | xvii

 Creating a Service Request with JTAC | xvii

1

Overview

EX3200 System Overview | 19

EX3200 Switches Hardware Overview | 19

 Benefit of the EX3200 Switch | 19

 EX3200 Switches | 20

 Uplink Modules | 20

 Power over Ethernet (PoE) Ports | 20

EX3200 Switch Models | 21

EX3200 Switch Hardware and CLI Terminology Mapping | 21

Chassis Physical Specifications for EX3200 Switches | 24

Field-Replaceable Units in EX3200 Switches | 24

EX3200 Chassis | 25

Front Panel of an EX3200 Switch | 25

Rear Panel of an EX3200 Switch | 26

LCD Panel in EX3200 Switches | 27

 LCD Panel Modes | 28

Uplink Modules in EX3200 Switches | 29

 SFP Uplink Module | 30

 SFP+ Uplink Module and SFP+ MACsec Uplink Module | 31

XFP Uplink Module | 33

Chassis Status LEDs in EX3200 Switches | 33

Management Port LEDs in EX3200 Switches | 35

Network Port LEDs in EX3200 Switches | 36

EX3200 Cooling System | 40

Fan Tray | 41

Airflow Direction in the EX3200 Switch Chassis | 41

EX3200 Power System | 43

Power Supply in EX3200 Switches | 43

AC Power Supplies | 44

DC Power Supplies | 45

PoE Power Budget and AC Power Supplies | 46

AC Power Supply LEDs in EX3200 Switches | 47

DC Power Supply LEDs in EX3200 Switches | 48

Power Specifications for EX3200 Switches | 48

AC Power Cord Specifications for EX3200 Switches | 50

2

Site Planning, Preparation, and Specifications

Site Preparation Checklist for EX3200 Switches | 53

EX3200 Site Guidelines and Requirements | 54

Environmental Requirements and Specifications for EX Series Switches | 55

General Site Guidelines | 60

Site Electrical Wiring Guidelines | 60

Rack Requirements | 61

Cabinet Requirements | 62

Requirements for Mounting an EX3200 Switch on a Desktop or Wall | 63

Clearance Requirements for Airflow and Hardware Maintenance for EX3200 Switches | 64

EX3200 Network Cable and Transceiver Planning | 65

Pluggable Transceivers Supported on EX3200 Switches | 66

SFP+ Direct Attach Copper Cables for EX Series Switches | 67

Cable Specifications | 67

List of DAC Cables Supported on EX Series Switches | 68

Standards Supported by These Cables | 68

Understanding EX Series Switches Fiber-Optic Cable Signal Loss, Attenuation, and Dispersion | 69

Signal Loss in Multimode and Single-Mode Fiber-Optic Cable | 69

Attenuation and Dispersion in Fiber-Optic Cable | 69

Calculating the Fiber-Optic Cable Power Budget for EX Series Devices | 70

Calculating the Fiber-Optic Cable Power Margin for EX Series Devices | 71

EX3200 Management Cable Specifications and Pinouts | 73

Management Cable Specifications | 73

Console Port Connector Pinout Information | 74

USB Port Specifications for an EX Series Switch | 74

RJ-45 Management Port Connector Pinout Information | 75

RJ-45 Port, SFP Port, SFP+ Port, QSFP+ Port, and QSFP28 Port Connector Pinout Information | 76

RJ-45 to DB-9 Serial Port Adapter Pinout Information | 80

Uplink Modules Connector Pinout Information for EX3200 Switches | 81

3

Initial Installation and Configuration

Unpacking and Mounting the EX3200 Switch | 92

Unpacking an EX3200 Switch | 92

Parts Inventory (Packing List) for an EX3200 Switch | 93

Register Products—Mandatory to Validate SLAs | 95

Installing and Connecting an EX3200 Switch | 95

Mounting an EX3200 Switch | 96

Mounting an EX3200 Switch on a Desk or Other Level Surface | 96

Mounting an EX3200 Switch on Two Posts in a Rack or Cabinet | 98

Mounting an EX3200 Switch on Four Posts in a Rack or Cabinet | 100

Mounting an EX3200 Switch in a Recessed Position in a Rack or Cabinet | 104

Mounting an EX3200 Switch on a Wall | 104

Connecting the EX3200 to Power | 106

Connect Earth Ground to an EX Series Switch | 107

Parts and Tools Required for Connecting an EX Series Switch to Earth Ground | 107

Special Instructions to Follow Before Connecting Earth Ground to an EX Series Switch | 112

Connecting Earth Ground to an EX Series Switch | 113

Connecting AC Power to an EX3200 Switch | 114

Connecting DC Power to an EX3200 Switch | 117

Connecting the EX3200 to External Devices | 120

Connect a Device to a Network for Out-of-Band Management | 121

Connect a Device to a Management Console Using an RJ-45 Connector | 121

Connecting the EX3200 to the Network | 123

Install a Transceiver | 123

Connect a Fiber-Optic Cable | 126

Configuring Junos OS on the EX3200 | 127

EX3200 Default Configuration | 127

Connecting and Configuring an EX Series Switch (CLI Procedure) | 132

Connecting and Configuring an EX Series Switch (J-Web Procedure) | 135

Configuring the LCD Panel on EX Series Switches (CLI Procedure) | 139

Disabling or Enabling Menus and Menu Options on the LCD Panel | 140

Configuring a Custom Display Message | 141

Dashboard for EX Series Switches | 142

Graphical Chassis Viewer | 143

System Information Panel | 145

Health Status Panel | 148

Capacity Utilization Panel | 152

Alarms Panel | 153

File System Usage | 153

Chassis Viewer | 153

4

Maintaining Components

Maintaining the EX3200 Cooling System | 172

Removing a Fan Tray from an EX3200 Switch | 172

Installing a Fan Tray in an EX3200 Switch | 173

Maintaining the EX3200 Power System | 175

Removing a Power Supply from an EX3200 Switch | 175

Installing a Power Supply in an EX3200 Switch | 176

Maintaining the Uplink Module in an EX3200 Switch | 178

Removing an Uplink Module from an EX3200 Switch | 178

Installing an Uplink Module in an EX3200 Switch | 180

Maintain Transceivers | 183

Remove a Transceiver | 183

Remove a QSFP28 Transceiver | 187

Install a Transceiver | 189

Install a QSFP28 Transceiver | 191

Maintain Fiber-Optic Cables | 193

Connect a Fiber-Optic Cable | 193

Disconnect a Fiber-Optic Cable | 194

How to Handle Fiber-Optic Cables | 195

5

Troubleshooting Hardware

Troubleshooting EX3200 Components | 198

Understand Alarm Types and Severity Levels on EX Series Switches | 198

Chassis Component Alarm Conditions on EX3200 Switches | 200

Check Active Alarms with the J-Web Interface | 204

Monitor System Log Messages | 205

Troubleshooting Network Interfaces on EX3200 Switches | 210

The interface on one of the last four built-in network ports in an EX3200 switch (for example, interface ge-0/0/23) is down | 211

The interface on the port in which an SFP or SFP+ transceiver is installed in an SFP+ uplink module is down | 211

Troubleshooting Uplink Module Installation or Replacement on EX3200 Switches | 212

One of the last four network ports on an EX3200 switch with an SFP or SFP+ uplink module installed is disabled | 212

A port on an SFP uplink module installed in an EX3200 switch is disabled | 212

Troubleshooting PoE Voltage Injection Failure in EX2300, EX3400, or EX4300 Switch Models with PoE Capability | 213

Troubleshoot Temperature Alarms in EX Series Switches | 213

6

Contacting Customer Support and Returning the Chassis or Components**Returning an EX3200 Switch or Component for Repair or Replacement | 220**

Returning an EX3200 Switch or Component for Repair or Replacement | 220

Locating the Serial Number on an EX3200 Switch or Component | 221

Listing the Switch and Components Details with the CLI | 221

Locating the Chassis Serial Number ID Label on an EX3200 Switch | 222

Locating the Serial Number ID Labels on FRUs in an EX3200 Switch | 222

Contact Customer Support to Obtain Return Material Authorization | 222

Packing an EX3200 Switch or Component for Shipping | 223

Packing an EX3200 Switch for Shipping | 225

Packing EX3200 Switch Components for Shipping | 225

7

Safety and Compliance Information

General Safety Guidelines and Warnings | 229

Definitions of Safety Warning Levels | 230

Qualified Personnel Warning | 233

Warning Statement for Norway and Sweden | 234

Fire Safety Requirements | 234

Fire Suppression | 234

Fire Suppression Equipment | 234

Installation Instructions Warning | 236

Chassis and Component Lifting Guidelines | 236

Restricted Access Warning | 238

Ramp Warning | 240

Rack-Mounting and Cabinet-Mounting Warnings | 241

Grounded Equipment Warning | 247

Radiation from Open Port Apertures Warning | 248

Laser and LED Safety Guidelines and Warnings | 249

General Laser Safety Guidelines | 249

Class 1 Laser Product Warning | 250

Class 1 LED Product Warning | 251

Laser Beam Warning | 252

Maintenance and Operational Safety Guidelines and Warnings | 252

Battery Handling Warning | 254

Jewelry Removal Warning | 255

Lightning Activity Warning | 257

Operating Temperature Warning | 258

Product Disposal Warning | 260

General Electrical Safety Guidelines and Warnings | 261

Action to Take After an Electrical Accident | 262

Prevention of Electrostatic Discharge Damage | 263

AC Power Electrical Safety Guidelines | 264

AC Power Disconnection Warning | 266

DC Power Electrical Safety Guidelines | 267

DC Power Disconnection Warning | 268

DC Power Grounding Requirements and Warning | 270

DC Power Wiring Sequence Warning | 272

DC Power Wiring Terminations Warning | 275

Multiple Power Supplies Disconnection Warning | 278

TN Power Warning | 279

Agency Approvals for EX Series Switches | 279

Compliance Statements for EMC Requirements for EX Series Switches | 280

Canada | 281

Taiwan | 282

European Community | 282

Israel | 282

Japan | 282

Korea | 283

United States | 283

FCC Part 15 Statement | 283

Nonregulatory Environmental Standards | 284

Compliance Statements for Acoustic Noise for EX Series Switches | 285

About the Documentation

IN THIS SECTION

- Documentation and Release Notes | xi
- Using the Examples in This Manual | xi
- Documentation Conventions | xiii
- Documentation Feedback | xvi
- Requesting Technical Support | xvi

Use this guide to install hardware and perform initial software configuration, routine maintenance, and troubleshooting for the EX3200 switch. After completing the installation and basic configuration procedures covered in this guide, refer to the Junos OS documentation for information about further software configuration.

Documentation and Release Notes

To obtain the most current version of all Juniper Networks® technical documentation, see the product documentation page on the Juniper Networks website at <https://www.juniper.net/documentation/>.

If the information in the latest release notes differs from the information in the documentation, follow the product Release Notes.

Juniper Networks Books publishes books by Juniper Networks engineers and subject matter experts. These books go beyond the technical documentation to explore the nuances of network architecture, deployment, and administration. The current list can be viewed at <https://www.juniper.net/books>.

Using the Examples in This Manual

If you want to use the examples in this manual, you can use the **load merge** or the **load merge relative** command. These commands cause the software to merge the incoming configuration into the current candidate configuration. The example does not become active until you commit the candidate configuration.

If the example configuration contains the top level of the hierarchy (or multiple hierarchies), the example is a *full example*. In this case, use the **load merge** command.

If the example configuration does not start at the top level of the hierarchy, the example is a *snippet*. In this case, use the **load merge relative** command. These procedures are described in the following sections.

Merging a Full Example

To merge a full example, follow these steps:

1. From the HTML or PDF version of the manual, copy a configuration example into a text file, save the file with a name, and copy the file to a directory on your routing platform.

For example, copy the following configuration to a file and name the file **ex-script.conf**. Copy the **ex-script.conf** file to the **/var/tmp** directory on your routing platform.

```
system {
  scripts {
    commit {
      file ex-script.xsl;
    }
  }
}
interfaces {
  fxp0 {
    disable;
    unit 0 {
      family inet {
        address 10.0.0.1/24;
      }
    }
  }
}
```

2. Merge the contents of the file into your routing platform configuration by issuing the **load merge** configuration mode command:

```
[edit]
user@host# load merge /var/tmp/ex-script.conf
load complete
```

Merging a Snippet

To merge a snippet, follow these steps:

1. From the HTML or PDF version of the manual, copy a configuration snippet into a text file, save the file with a name, and copy the file to a directory on your routing platform.

For example, copy the following snippet to a file and name the file **ex-script-snippet.conf**. Copy the **ex-script-snippet.conf** file to the **/var/tmp** directory on your routing platform.

```
commit {  
  file ex-script-snippet.xml; }  
}
```

2. Move to the hierarchy level that is relevant for this snippet by issuing the following configuration mode command:

```
[edit]  
user@host# edit system scripts  
[edit system scripts]
```

3. Merge the contents of the file into your routing platform configuration by issuing the **load merge relative** configuration mode command:

```
[edit system scripts]  
user@host# load merge relative /var/tmp/ex-script-snippet.conf  
load complete
```

For more information about the **load** command, see [CLI Explorer](#).

Documentation Conventions

[Table 1](#) on page [xiv](#) defines notice icons used in this guide.

Table 1: Notice Icons







Icon	Meaning	Description
	Informational note	Indicates important features or instructions.
	Caution	Indicates a situation that might result in loss of data or hardware damage.
	Warning	Alerts you to the risk of personal injury or death.
	Laser warning	Alerts you to the risk of personal injury from a laser.
	Tip	Indicates helpful information.
	Best practice	Alerts you to a recommended use or implementation.

Table 2 on page xiv defines the text and syntax conventions used in this guide.

Table 2: Text and Syntax Conventions

Convention	Description	Examples
Bold text like this	Represents text that you type.	To enter configuration mode, type the configure command: user@host> configure
Fixed-width text like this	Represents output that appears on the terminal screen.	user@host> show chassis alarms No alarms currently active
<i>Italic text like this</i>	<ul style="list-style-type: none"> Introduces or emphasizes important new terms. Identifies guide names. Identifies RFC and Internet draft titles. 	<ul style="list-style-type: none"> A policy <i>term</i> is a named structure that defines match conditions and actions. <i>Junos OS CLI User Guide</i> RFC 1997, <i>BGP Communities Attribute</i>

Table 2: Text and Syntax Conventions (*continued*)

Convention	Description	Examples
<i>Italic text like this</i>	Represents variables (options for which you substitute a value) in commands or configuration statements.	Configure the machine's domain name: [edit] root@# set system domain-name <i>domain-name</i>
Text like this	Represents names of configuration statements, commands, files, and directories; configuration hierarchy levels; or labels on routing platform components.	<ul style="list-style-type: none"> To configure a stub area, include the stub statement at the [edit protocols ospf area area-id] hierarchy level. The console port is labeled CONSOLE.
< > (angle brackets)	Encloses optional keywords or variables.	stub <default-metric <i>metric</i> >;
(pipe symbol)	Indicates a choice between the mutually exclusive keywords or variables on either side of the symbol. The set of choices is often enclosed in parentheses for clarity.	broadcast multicast (<i>string1</i> <i>string2</i> <i>string3</i>)
# (pound sign)	Indicates a comment specified on the same line as the configuration statement to which it applies.	rsvp { # Required for dynamic MPLS only
[] (square brackets)	Encloses a variable for which you can substitute one or more values.	community name members [<i>community-ids</i>]
Indentation and braces ({ })	Identifies a level in the configuration hierarchy.	[edit] routing-options { static { route default { nexthop <i>address</i> ; retain; } } }
;(semicolon)	Identifies a leaf statement at a configuration hierarchy level.	

GUI Conventions

Table 2: Text and Syntax Conventions (*continued*)

Convention	Description	Examples
Bold text like this	Represents graphical user interface (GUI) items you click or select.	<ul style="list-style-type: none"> In the Logical Interfaces box, select All Interfaces. To cancel the configuration, click Cancel.
> (bold right angle bracket)	Separates levels in a hierarchy of menu selections.	In the configuration editor hierarchy, select Protocols>Ospf .

Documentation Feedback

We encourage you to provide feedback so that we can improve our documentation. You can use either of the following methods:

- Online feedback system—Click TechLibrary Feedback, on the lower right of any page on the [Juniper Networks TechLibrary](#) site, and do one of the following:

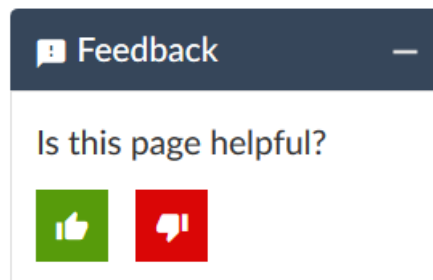

- Click the thumbs-up icon if the information on the page was helpful to you.
- Click the thumbs-down icon if the information on the page was not helpful to you or if you have suggestions for improvement, and use the pop-up form to provide feedback.
- E-mail—Send your comments to techpubs-comments@juniper.net. Include the document or topic name, URL or page number, and software version (if applicable).

Requesting Technical Support

Technical product support is available through the Juniper Networks Technical Assistance Center (JTAC). If you are a customer with an active Juniper Care or Partner Support Services support contract, or are

covered under warranty, and need post-sales technical support, you can access our tools and resources online or open a case with JTAC.

- JTAC policies—For a complete understanding of our JTAC procedures and policies, review the *JTAC User Guide* located at <https://www.juniper.net/us/en/local/pdf/resource-guides/7100059-en.pdf>.
- Product warranties—For product warranty information, visit <https://www.juniper.net/support/warranty/>.
- JTAC hours of operation—The JTAC centers have resources available 24 hours a day, 7 days a week, 365 days a year.

Self-Help Online Tools and Resources

For quick and easy problem resolution, Juniper Networks has designed an online self-service portal called the Customer Support Center (CSC) that provides you with the following features:

- Find CSC offerings: <https://www.juniper.net/customers/support/>
- Search for known bugs: <https://prsearch.juniper.net/>
- Find product documentation: <https://www.juniper.net/documentation/>
- Find solutions and answer questions using our Knowledge Base: <https://kb.juniper.net/>
- Download the latest versions of software and review release notes: <https://www.juniper.net/customers/csc/software/>
- Search technical bulletins for relevant hardware and software notifications: <https://kb.juniper.net/InfoCenter/>
- Join and participate in the Juniper Networks Community Forum: <https://www.juniper.net/company/communities/>
- Create a service request online: <https://myjuniper.juniper.net>

To verify service entitlement by product serial number, use our Serial Number Entitlement (SNE) Tool: <https://entitlementsearch.juniper.net/entitlementsearch/>

Creating a Service Request with JTAC

You can create a service request with JTAC on the Web or by telephone.

- Visit <https://myjuniper.juniper.net>.
- Call 1-888-314-JTAC (1-888-314-5822 toll-free in the USA, Canada, and Mexico).

For international or direct-dial options in countries without toll-free numbers, see <https://support.juniper.net/support/requesting-support/>.

1

CHAPTER

Overview

EX3200 System Overview | 19

EX3200 Chassis | 25

EX3200 Cooling System | 40

EX3200 Power System | 43

EX3200 System Overview

IN THIS SECTION

- [EX3200 Switches Hardware Overview | 19](#)
- [EX3200 Switch Models | 21](#)
- [EX3200 Switch Hardware and CLI Terminology Mapping | 21](#)
- [Chassis Physical Specifications for EX3200 Switches | 24](#)
- [Field-Replaceable Units in EX3200 Switches | 24](#)

EX3200 Switches Hardware Overview

IN THIS SECTION

- [Benefit of the EX3200 Switch | 19](#)
- [EX3200 Switches | 20](#)
- [Uplink Modules | 20](#)
- [Power over Ethernet \(PoE\) Ports | 20](#)

Juniper Networks EX Series Ethernet Switches provide scalable connectivity for the enterprise market, including branch offices, campus locations, and data centers. The switches run the Juniper Networks Junos operating system (Junos OS), which provides Layer 2 and Layer 3 switching, routing, and security services. The same Junos OS code base that runs on EX Series switches also runs on all Juniper Networks M Series, MX Series, and T Series routers.

Benefit of the EX3200 Switch

Compact solution—The EX3200 switch is a modular single rack unit device that is an apt solution for crowded wiring closets and access switch locations such as data center, campus, and branch office environments. It provides carrier-class reliability of modular systems with the economics and flexibility of stackable platforms.

EX3200 Switches

Juniper Networks EX3200 Ethernet Switches provide connectivity for low-density environments. Typically, you deploy these switches in branch environments or wiring closets where only one switch is required.

EX3200 switches are available in models with either 24 or 48 ports and with either all ports equipped for Power over Ethernet (PoE) or only 8 ports equipped for PoE. EX3200 switches with a DC power supply installed do not provide PoE. All models provide ports that have 10/100/1000Base-T Gigabit Ethernet connectors and optional 1-gigabit small form-factor pluggable (SFP) transceivers, 10-gigabit small form-factor pluggable (SFP+) transceivers, or 10-gigabit small form-factor pluggable (XFP) transceivers for use with fiber connections.

EX3200 switches include:

- A field-replaceable power supply and an optional additional connection to an external power source.
- A field-replaceable fan tray with single fan.
- Junos OS with its modular design that enables failed system processes to gracefully restart.

EX3200 switches have these features:

- Run Junos OS for EX Series switches
- Have options of 24-port and 48-port models
- Have options of full (all ports) or partial (8 ports) Power over Ethernet (PoE) capability
- Have optional uplink modules that provide connection to distribution switches

Uplink Modules

Optional uplink modules are available for all EX3200 switches. Uplink modules provide two 10-gigabit small form-factor pluggable (XFP) transceivers, four 1-gigabit small form-factor pluggable (SFP) transceivers, or two 10-gigabit small form-factor pluggable (SFP+) transceivers. You can use XFP, SFP, or SFP+ ports to connect an access switch to a distribution switch.

Power over Ethernet (PoE) Ports

PoE ports provide electrical current to devices through the network cables so that separate power cords for devices such as IP phones, wireless access points, and security cameras are unnecessary.

PoE is defined in the IEEE 802.3af standard. In this standard, the amount of power that can be supplied to a powered device is limited to 15.4 W. Starting with Junos OS Release 11.1, EX3200 switches support enhanced PoE, a Juniper Networks extension to the IEEE 802.3af PoE standard that permits up to 18.6 W per PoE port.

EX3200 switches with an AC power supply installed have options of full (all 24 or 48 ports) or partial (8 ports) PoE capability. EX3200 switches with a DC power supply installed do not provide PoE.

Full PoE models are primarily used in IP telephony environments. Partial PoE models are used in environments where, for example, only a few ports for wireless access points or security cameras are required.

EX3200 Switch Models

The EX3200 switch is available with 24 or 48 ports with partial or full Power over Ethernet (PoE) capability. EX3200 switches with a DC power supply installed do not provide PoE. [Table 3 on page 21](#) lists the EX3200 switch models.

Table 3: EX3200 Switch Models

Model	Typical Deployment	Access Ports	Number of PoE-enabled Ports	Power Supply (Minimum)
EX3200-24T	Access or Distribution switch	24 Gigabit Ethernet	First 8 ports	320 W
EX3200-48T	Access or Distribution switch	48 Gigabit Ethernet	First 8 ports	320 W
EX3200-24P	Access switch	24 Gigabit Ethernet	All 24 ports	600 W
EX3200-48P	Access switch	48 Gigabit Ethernet	All 48 ports	930 W
EX3200-24T-DC	Access or Distribution switch	24 Gigabit Ethernet	0	190 W
EX3200-48T-DC	Access or Distribution switch	48 Gigabit Ethernet	0	190 W

EX3200 Switch Hardware and CLI Terminology Mapping

This topic describes the hardware terms used in EX3200 switch documentation and the corresponding terms used in the Junos OS command line interface (CLI). See [Table 4 on page 22](#).

Table 4: CLI Equivalents of Terms Used in Documentation for EX3200 Switches

Hardware Item (CLI)	Description (CLI)	Value (CLI)	Item in Documentation	Additional Information
Chassis	One of the following: <ul style="list-style-type: none"> EX3200-24T EX3200-24P EX3200-48T EX3200-48P 	-	Switch chassis	“Chassis Physical Specifications for EX3200 Switches” on page 24
FPC (n)	Abbreviated name of the Flexible PIC Concentrator (FPC) One of the following: <ul style="list-style-type: none"> EX3200-24T EX3200-24P EX3200-48T EX3200-48P 	Value of n is always 0.	The switch does not have actual FPCs. In this case, FPC refers to the switch itself.	<i>Understanding Interface Naming Conventions</i>
PIC (n)	Abbreviated name of the Physical Interface Card (PIC)	n is a value in the range of 0–1.	The switch does not have actual PIC devices; see entries for PIC 0 through PIC1 for the equivalent item on the switch.	<i>Understanding Interface Naming Conventions</i>

Table 4: CLI Equivalents of Terms Used in Documentation for EX3200 Switches (continued)

Hardware Item (CLI)	Description (CLI)	Value (CLI)	Item in Documentation	Additional Information
	One of the following: <ul style="list-style-type: none"> • 24x 10/100/1000 Base-T • 48x 10/100/1000 Base-T 	PIC 0	Built-in network ports on the front panel of the switch	“Front Panel of an EX3200 Switch” on page 25
	One of the following: <ul style="list-style-type: none"> • 2x 10GE SFP+ • 4x GE SFP • 2x 10 GE XFP 	PIC 1	Uplink module installed on the front panel of the switch	“Uplink Modules in EX3200 Switches” on page 29
Xcvr (n)	Abbreviated name of the transceiver	n is a value equivalent to the number of the port in which the transceiver is installed.	Optical transceivers	“Pluggable Transceivers Supported on EX3200 Switches” on page 66
Power supply (n)	One of the following: <ul style="list-style-type: none"> • PS 320W AC • PS 600W AC • PS 930W AC • PS 190W DC 	Value of n is always 0. The value corresponds to the power supply slot number.	AC or DC power supply	“Power Supply in EX3200 Switches” on page 43
Fan tray	Fan tray	-	Fan tray	“EX3200 Cooling System” on page 40

Chassis Physical Specifications for EX3200 Switches

The EX3200 switch chassis is a rigid sheet-metal structure that houses the hardware components. [Table 5 on page 24](#) summarizes the physical specifications of the EX3200 switch chassis.

Table 5: Physical Specifications of the Switch Chassis

Description	Value
Chassis height	1.75 in. (4.45 cm)
Chassis width	<ul style="list-style-type: none"> • 17.25 in. (43.82 cm) • 19 in. (48.2 cm) with mounting brackets attached
Chassis depth	<ul style="list-style-type: none"> • Without power supply installed—17 in. (43.18 cm) • With power supply installed: <ul style="list-style-type: none"> • 320 W AC power supply or 190 W DC power supply installed—17 in. (43.18 cm) • 600 W or 930 W AC power supply installed—19.25 in. (48.9 cm)
Weight	<ul style="list-style-type: none"> • 320 W AC power supply: 2.5 lb (1.1 kg) • 600 W and 930 W AC power supplies: 3.1 lb (1.4 kg) • 190 W DC power supply: 2.5 lb (1.1 kg)

NOTE: The weight of an EX3200 switch with one power supply installed is between 15–17 lb (6.8–7.7 kg).

Field-Replaceable Units in EX3200 Switches

Field-replaceable units (FRUs) are components that you can replace at your site. The FRUs in the switch are:

- Power supply
- Fan tray
- Uplink module
- Transceivers

NOTE: Uplink modules are not part of the standard package and must be ordered separately.

The fan tray, uplink module, and transceivers are hot-removable and hot-insertable: You can remove and replace them without powering off the switch or disrupting switch functions.

NOTE: If you have a Juniper J-Care service contract, register any addition, change, or upgrade of hardware components at <https://www.juniper.net/customers/support/tools/updateinstallbase/> . Failure to do so can result in significant delays if you need replacement parts. This note does not apply if you replace existing components with the same type of component.

EX3200 Chassis

IN THIS SECTION

- Front Panel of an EX3200 Switch | 25
- Rear Panel of an EX3200 Switch | 26
- LCD Panel in EX3200 Switches | 27
- Uplink Modules in EX3200 Switches | 29
- Chassis Status LEDs in EX3200 Switches | 33
- Management Port LEDs in EX3200 Switches | 35
- Network Port LEDs in EX3200 Switches | 36

Front Panel of an EX3200 Switch

The front panel of an EX3200 switch consists of the following components:

- 10/100/1000Base-T Gigabit Ethernet ports, some or all of which are enabled for Power over Ethernet (PoE)
- Uplink module ports—SFP, SFP+, or XFP ports (Installing the uplink module is an optional feature.)

- LCD panel and the LCD navigation buttons
- Chassis status LEDs
- Network port LEDs

Figure 1 on page 26 shows the front panel of an EX3200 switch with 48 Gigabit Ethernet ports.

Figure 2 on page 26 shows the front panel of an EX3200 switch with 24 Gigabit Ethernet ports. Models are available that have either all ports equipped for Power over Ethernet (PoE) or only 8 ports equipped for PoE. All ports have 10/100/1000Base-T Gigabit Ethernet connectors.

Figure 1: EX3200 Switch with 48 Gigabit Ethernet Ports

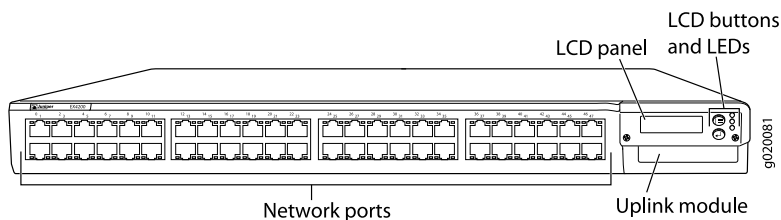
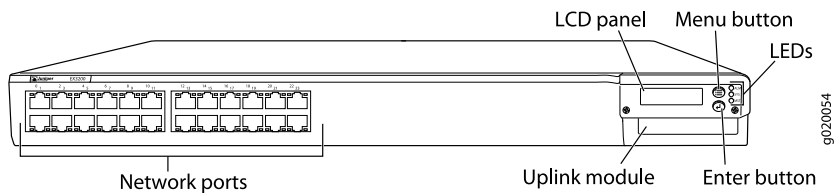

Figure 2: EX3200 Switch with 24 Gigabit Ethernet Ports



SEE ALSO

[Chassis Status LEDs in EX3200 Switches](#) | 33

Rear Panel of an EX3200 Switch

The rear panel of the EX3200 switch consists of the following components:

- Protective earthing terminal
- Temperature shutdown LED
- Management Ethernet port
- Console port
- USB port

- ESD point
- Fan tray
- Power supply

Figure 3 on page 27 shows the rear panel of an EX3200 switch with a 320 W power supply. All EX3200 switches have the same rear panel. The 320 W AC power supply and the 190 W DC power supply are flush with the chassis. The 600 W AC power supply and 930 W AC power supply extend out of the chassis by 2.25 in. The power cord retainer clips extend out of the power supply by 3 in.

Figure 3: EX3200 Switch Rear Panel

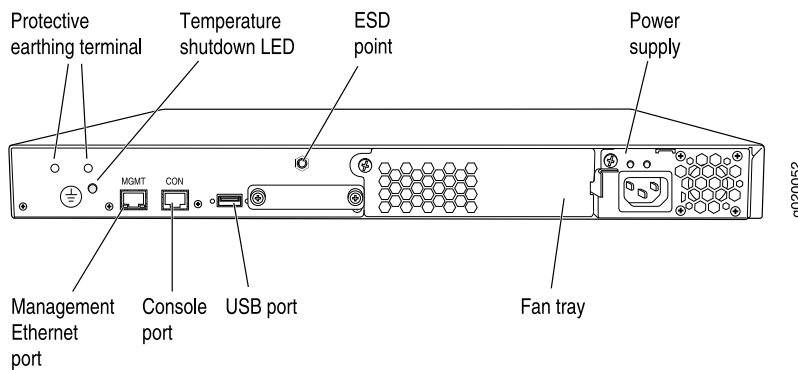

LCD Panel in EX3200 Switches

IN THIS SECTION

- [LCD Panel Modes | 28](#)

The LCD panel on the front panel of the switch shows two lines of text, each of which can contain a maximum of 16 characters. The LCD panel displays a variety of information about the switch and also provides a menu to perform basic operations such as initial setup and reboot.

There are two navigation buttons—**Menu** and **Enter**—to the right of the LCD panel.

See [Figure 4 on page 28](#).

Figure 4: LCD Panel

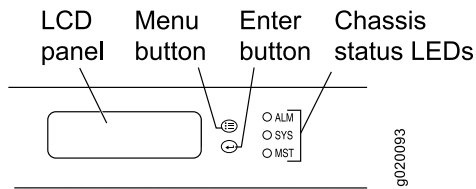

You can configure the second line of the LCD panel to display a custom message. If the LCD panel is configured to display a custom message, the **Menu** button and the **Enter** button are disabled. See [“Configuring the LCD Panel on EX Series Switches \(CLI Procedure\)” on page 139](#).

The LCD panel has a backlight. If the LCD panel is idle for 60 seconds, the backlight turns off. You can turn on the backlight by pressing the **Menu** or **Enter** button once. After turning on the backlight, you can toggle between the LCD panel menus by pressing the **Menu** button and navigate through the menu options by pressing the **Enter** button.

NOTE: The chassis viewer in the J-Web interface also displays the LCD panel. From the J-Web interface, you can view real-time status information in the LCD panel. See [“Dashboard for EX Series Switches” on page 142](#).

LCD Panel Modes

The LCD panel operates in four modes: boot, idle, status, and maintenance.

The LCD panel operates in boot mode during switch reboot. The boot mode displays the key milestones in the switch boot process. The boot mode does not have any menu options. After the boot process is complete, the LCD panel automatically reverts to the Idle menu.

In an EX3200 switch, the first line of the LCD panel displays the hostname.

In the idle mode, the second line displays the mode of the network ports' Status LED and the number of chassis alarms. The number of alarms is updated every second.

In the status mode, the second line displays:

- Status of the power supply
- Status of the fan and temperature
- Version of Junos OS for EX Series switches loaded on the switch

In the maintenance mode, the second line displays one of the following options that you can use to configure or troubleshoot the switch:

- System halt
- System reboot
- Load rescue
- Factory default
- System EZSetup

Uplink Modules in EX3200 Switches

IN THIS SECTION

- SFP Uplink Module | 30
- SFP+ Uplink Module and SFP+ MACsec Uplink Module | 31
- XFP Uplink Module | 33

EX3200 switches support three types of uplink modules:

- SFP uplink module—Provides four ports for 1-gigabit small form-factor pluggable (SFP) transceivers. The model number of the uplink module is EX-UM-4SFP.

NOTE: On an EX3200 switch, if you install a transceiver in a 1-Gigabit Ethernet uplink module port, a corresponding network port from the last four built-in ports is disabled.

For example, if you install a transceiver in the uplink module port 3 (**ge-0/1/2**), then the built-in port 23 (**ge-0/0/22**) is disabled.

The disabled port is not listed in the output of **show interface** commands.

On an EX3200 switch, if you replace a transceiver multiple times in quick succession in a port that uses fiber-optic connectors, the switch might not create an interface for that port and that port might be disabled.

For example, if you replace an SFP transceiver in port 2 on the uplink module (**ge-0/1/2**) multiple times in quick succession, then **ge-0/1/2** might be disabled.

The disabled port is not listed in the output of the **show interface** command.

- SFP+ uplink module—Provides two ports for 10-gigabit small form-factor pluggable (SFP+) transceivers when configured to operate in 10-gigabit mode or four ports for 1-gigabit small form-factor pluggable

(SFP) transceivers when configured to operate in 1-gigabit mode. The model number of the uplink module is EX-UM-2X4SFP.

NOTE: On an EX3200 switch, if you install a transceiver in an SFP+ uplink module when the uplink module is operating in the 1-gigabit mode, a corresponding network port from the last four built-in ports is disabled.

For example, if you install an SFP transceiver in port 2 on the uplink module (ge-0/1/2), then ge-0/0/22 is disabled. The disabled port is not listed in the output of the **show interface** command.

- XFP uplink module—Provides two ports for 10-gigabit small form-factor pluggable (XFP) transceivers.

NOTE: When a new uplink module is installed in the switch or an existing uplink module is replaced with another uplink module, the switch detects the newly installed uplink module. The switch creates the required interfaces if the uplink module has transceivers in its ports and when new transceivers are installed in uplink module ports.

When connecting uplink module ports, you can install an SFP uplink module at one end of the connection and install an SFP+ uplink module configured to operate in the 1-gigabit mode at the other end. Likewise, you can install an XFP uplink module at one end of the connection and install an SFP+ uplink module configured to operate in the 10-gigabit mode at the other end.

SFP Uplink Module

[Figure 5 on page 31](#) shows the SFP uplink module, which provides four ports for 1-gigabit SFP transceivers.

Figure 5: SFP Uplink Module

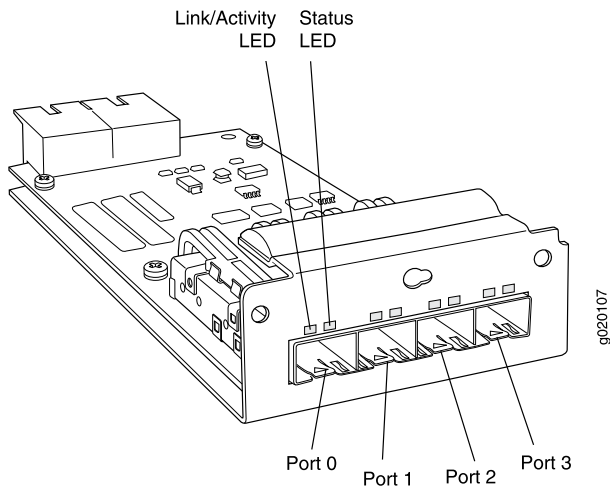

SFP uplink modules are shipped with dust covers preinstalled in the ports.

The SFP uplink module requires Junos OS for EX Series switches, Release 9.0 or later.

SFP+ Uplink Module and SFP+ MACsec Uplink Module

The SFP+ uplink module and the SFP+ MACsec uplink module can be used for either SFP+ or SFP transceivers. You configure the operating mode on the module to match the type of transceiver you want to use—for SFP+ transceivers, you configure the 10-gigabit operating mode, and for SFP transceivers, you configure the 1-gigabit operating mode. See *Setting the Mode on an SFP+ or SFP+ MACSec Uplink Module* .

By default, the SFP+ uplink module and the SFP+ MACsec uplink module operate in the 10-gigabit mode and support only SFP+ transceivers. If you have not changed the module from the default setting and you want to use SFP+ transceivers, you do not need to configure the operating mode.

If the operating mode and the configured mode for the uplink module are different, it is shown in the output of **show chassis pic fpc-slot slot number pic-slot 1**.

[Figure 6 on page 32](#) shows the SFP+ uplink module and the SFP+ MACsec uplink module.

Figure 6: SFP+ and SFP+ MACsec Uplink Module

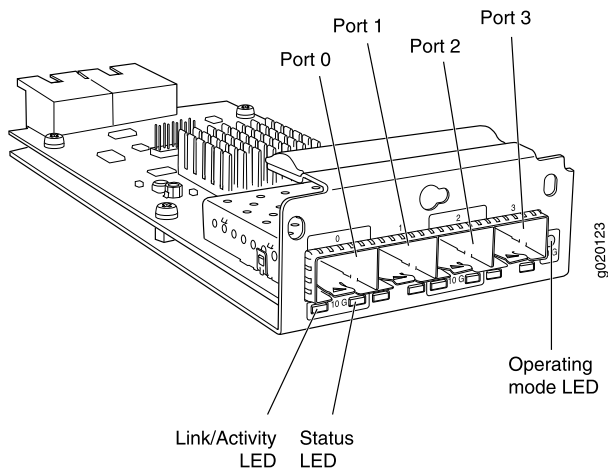

The following transceivers can be installed in the uplink module ports:

- SFP+ transceivers are supported in ports 0 and 2.
- SFP transceivers are supported in all four ports.

The ports that support SFP+ transceivers are labeled 10 G on the uplink module's faceplate (see [Figure 6 on page 32](#)).

NOTE: When an SFP+ uplink module or an SFP+ MACsec uplink module is operating in 10-gigabit mode:

- Only the 10-gigabit ports (ports 0 and 2) are enabled.
- You can use only SFP+ transceivers in those ports.

When an SFP+ uplink module or an SFP+ MACsec uplink module is operating in 1-gigabit mode:

- All four ports are enabled.
- You can use only SFP transceivers in all four ports.

The SFP+ uplink module and the SFP+ MACsec uplink module have an LED on the faceplate (labeled Operating mode LED in [Figure 6 on page 32](#)) that indicates the operating mode. If the uplink module is operating in the 10-gigabit mode, the LED is lit. If the uplink module is operating in the 1-gigabit mode, the LED is unlit.

SFP+ uplink modules and the SFP+ MACsec uplink modules are shipped with dust covers preinstalled in the ports.

The SFP+ uplink module requires Junos OS for EX Series switches, Release 9.4 or later. The SFP+ MACsec uplink module requires Junos OS for EX Series switches, Release 13.2X50-D10 or later.

XFP Uplink Module

Figure 7 on page 33 shows the XFP uplink module, which provides two ports for 10-gigabit XFP transceivers.

Figure 7: XFP Uplink Module

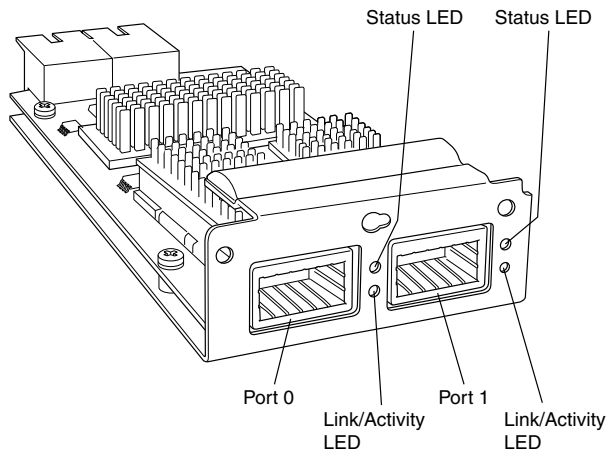

XFP uplink modules are shipped with a dust cover preinstalled in one port.

The XFP uplink module requires Junos OS for EX Series switches, Release 9.0 or later.

SEE ALSO

[Installing an Uplink Module in an EX3200 Switch | 180](#)

[Troubleshooting Uplink Module Installation or Replacement on EX3200 Switches | 212](#)

Chassis Status LEDs in EX3200 Switches

The front panel of an EX3200 switch has three LEDs on the far right side of the panel, next to the LCD panel (see [Figure 8 on page 33](#)).

Figure 8: Chassis Status LEDs in an EX3200 Switch

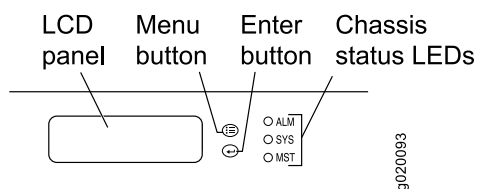

Table 6 on page 34 describes the chassis status LEDs in an EX3200 switch, their colors and states, and the status they indicate. You can view the colors of the three LEDs remotely through the CLI by issuing the operational mode command *show chassis lcd*.

Table 6: Chassis Status LEDs in an EX3200 Switch

LED Label	Color	State and Description
ALM (Alarm)	Unlit	There is no alarm or the switch is halted.
	Red	<p>There is a major alarm.</p> <p>NOTE: When you connect power to the switch, the Alarm (ALM) LED lights red. Plugging an active Ethernet cable into the management (MGMT) port on the switch completes the network link and turns off the ALM LED. (See “Connect a Device to a Network for Out-of-Band Management” on page 121.)</p> <p>Connecting the switch to a dedicated management console instead of a network does not affect the ALM LED. The LED remains red until the switch is connected to a network.</p>
	Amber	<p>There is a minor alarm.</p> <p>NOTE: The Alarm (ALM) LED lights amber if you commit a configuration to make it active on the switch, but do not create a rescue configuration to back it up. To save the most recently committed configuration as the rescue configuration, enter the operational mode command <i>request system configuration rescue save</i>.</p>
SYS (System)	Green	<ul style="list-style-type: none"> • On steadily—Junos OS for EX Series switches has been loaded on the switch. • Blinking—The switch is booting. • Off—The switch is powered off or is halted.
MST (Primary)	Green	This LED is meaningful only on EX4200 switches.

A major alarm (red) indicates a critical error condition that requires immediate action.

A minor alarm (amber) indicates a noncritical condition that requires monitoring or maintenance. A minor alarm that is left unchecked might cause interruption in service or performance degradation.

NOTE: The amber glow of the Alarm LED that indicates a minor alarm closely resembles the red glow that indicates a major alarm.

All three LEDs can be lit simultaneously.

Management Port LEDs in EX3200 Switches

The management port on EX3200 switches has two LEDs that indicate link/activity and port status (see [Figure 9 on page 35](#)). The management port is set to full-duplex and the speed is set to 100 Mbps.

Figure 9: LEDs on the Management Port on an EX3200 Switch

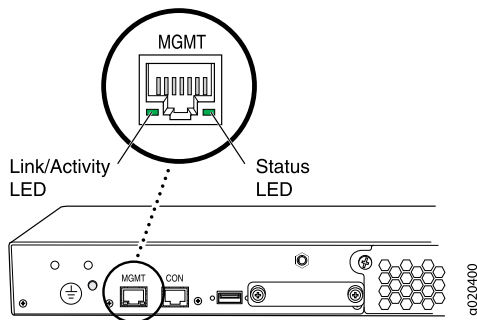

[Table 7 on page 35](#) describes the Link/Activity LED.

Table 7: Link/Activity LED on the Management Port on EX3200 Switches

LED	Color	State and Description
Link/Activity	Green	<ul style="list-style-type: none"> • Blinking—The port and the link are active, and there is link activity. • On steadily—The port and the link are active, but there is no link activity. • Off—The port is not active.

[Table 8 on page 35](#) describes the Status LED (administrative status).

Table 8: Status LED on the Management Port on EX3200 Switches

LED	Color	State and Description
Status	Green	<ul style="list-style-type: none"> • On steadily—Administrative status is enabled. • Off—Administrative status is disabled.

Network Port LEDs in EX3200 Switches

Each network port on the switch has two LEDs. The four figures in this topic show the location of those LEDs:

- [Figure 10 on page 36](#) shows the location of the LEDs on the network ports on the front panel.
- [Figure 11 on page 36](#) shows the location of the LEDs on the uplink module ports on the SFP uplink module.
- [Figure 12 on page 37](#) shows the location of the LEDs on the uplink module ports on the SFP+ and SFP+ MACsec uplink modules.
- [Figure 13 on page 37](#) shows the location of the LEDs on the uplink module ports on the XFP uplink module.

Figure 10: LEDs on the Network Ports on the Front Panel

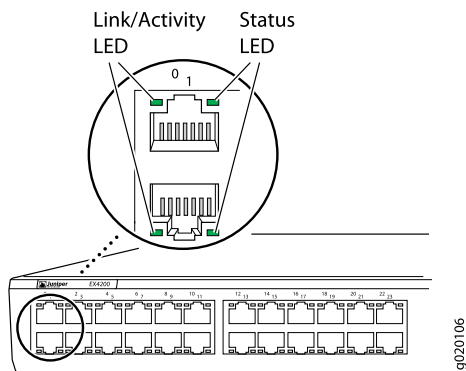

Figure 11: LEDs on the Uplink Module Ports on the SFP Uplink Module

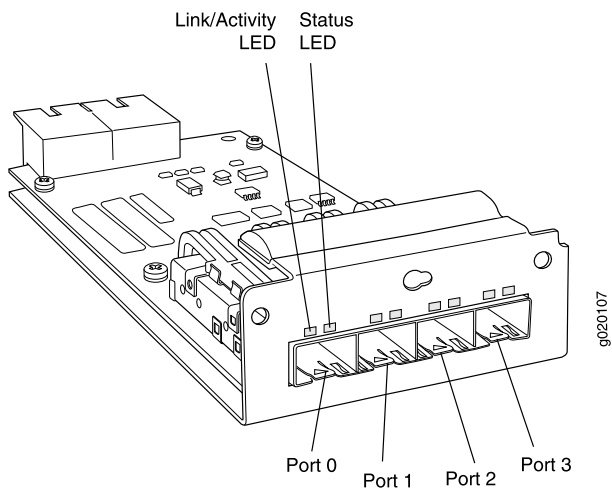

Figure 12: LEDs on the Uplink Module Ports on the SFP+ and SFP+ MACsec Uplink Modules

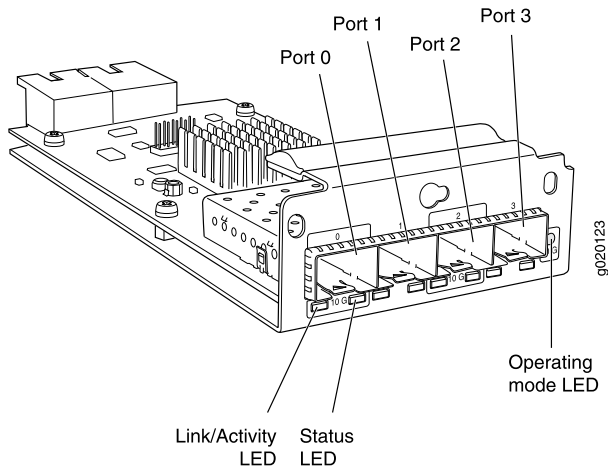
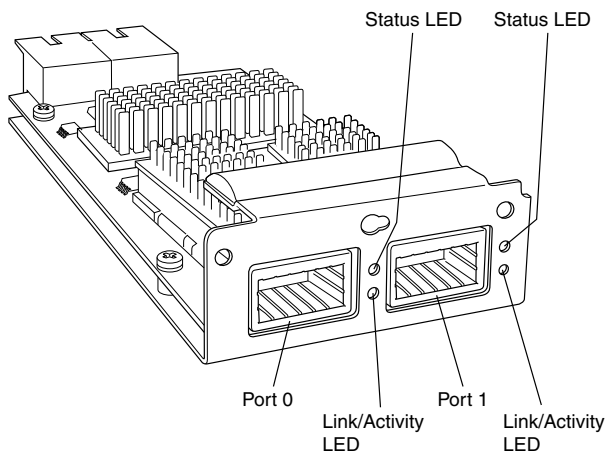

Figure 13: LEDs on the Uplink Module Ports on the XFP Uplink Module



The LEDs labeled Link/Activity LED in [Figure 10 on page 36](#), [Figure 11 on page 36](#), [Figure 12 on page 37](#), and [Figure 13 on page 37](#) indicate link activity. The LEDs labeled Status LED in [Figure 10 on page 36](#), [Figure 11 on page 36](#), [Figure 12 on page 37](#), and [Figure 13 on page 37](#) indicate the status of one of the four port parameters. The port parameters are administrative status, duplex mode, Power over Ethernet (PoE) status, and speed.

[Table 9 on page 38](#) describes the Link/Activity LED.

Table 9: Link/Activity LED on Network Ports

LED	Color	State and Description
Link/Activity	Green	<ul style="list-style-type: none">● Blinking—The port and the link are active, and there is link activity.● On steadily—The port and the link are active, but there is no link activity.● Off—The port is not active.

[Table 10 on page 39](#) describes the Status LED. From the Idle menu of the LCD, use the **Enter** button on the LCD panel to toggle between the ADM, DPX, POE, and SPD indicators.

Table 10: Status LED on Network Ports

LED	LCD Indicator	State and Description
Status	LED: ADM	<p>Indicates the administrative status (enabled or disabled). The status indicators are:</p> <ul style="list-style-type: none"> ● Green—Administrative status enabled. ● Unlit—Administrative status disabled.
	LED: DPX	<p>Indicates the duplex mode.</p> <p>The uplink module ports are always set to full-duplex; therefore, the LED is always green.</p> <p>The status indicators for network ports on the front panel are:</p> <ul style="list-style-type: none"> ● Green—Port is set to full-duplex mode. ● Unlit—Port is set to half-duplex mode.
	LED: MACsec	<p>Indicates the MACsec status (enabled or disabled). MACsec can be enabled only if you have installed the SFP+ MACsec uplink module. The status indicators are:</p> <ul style="list-style-type: none"> ● Green—MACsec is enabled on the port. ● Unlit—MACsec is disabled on the port.
	LED: POE	<p>Indicates the PoE status on switches with PoE-enabled ports.</p> <p>Here the term POE refers to both PoE and PoE+ as applicable.</p> <p>PoE is not enabled on uplink module ports; therefore, the LED for those ports is always unlit.</p> <p>The status indicators for network ports on the front panel are:</p> <ul style="list-style-type: none"> ● Green—PoE is enabled on the port. ● Amber—PoE is enabled on the port, but no power is drawn from the port because of one of the following: <ul style="list-style-type: none"> ● No device that draws power from the port is connected to the port. ● A device that draws power from the port is connected to the port, but the device is not drawing any power from the port. ● Unlit—PoE is not enabled on the port.
	LED: SPD	<p>Indicates the speed.</p> <p>The speed indicators for network ports on the front panel are:</p>

Table 10: Status LED on Network Ports *(continued)*

LED	LCD Indicator	State and Description
		<ul style="list-style-type: none"> • One blink per second—10 Mbps • Two blinks per second—100 Mbps • Three blinks per second—1000 Mbps <p>The speed indicators for network ports on the SFP uplink module are:</p> <ul style="list-style-type: none"> • Green—1000 Mbps • Unlit—10/100 Mbps <p>The speed indicators for network ports on the SFP+ and SFP+ MACsec uplink module are:</p> <ul style="list-style-type: none"> • Green—The speed of the transceiver installed in the port is the same as the speed at which the uplink module port is configured to operate. • Unlit—The speed of the transceiver installed in the port is not the same as the speed at which the uplink module port is configured to operate. <p>The speed of the XFP uplink module ports is always 10 Gbps, which is also the speed of XFP transceivers, therefore, this LED is always green on an XFP uplink module.</p>

EX3200 Cooling System

IN THIS SECTION

- [Fan Tray | 41](#)
- [Airflow Direction in the EX3200 Switch Chassis | 41](#)

The cooling system in an EX3200 switch consists of a field-replaceable unit (FRU) fan tray with one fan (see [Figure 14 on page 41](#)).

Fan Tray

The fan tray is located at the rear of the chassis. See [Figure 14 on page 41](#)

Figure 14: Fan Tray Used in an EX3200 Switch

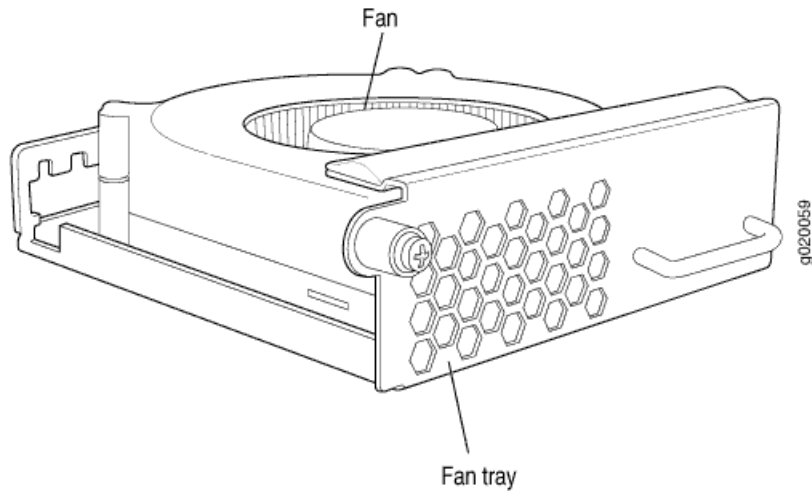

Airflow Direction in the EX3200 Switch Chassis

The fan tray located at the rear of the chassis provides side-to-rear chassis cooling. See [Figure 15 on page 42](#)

Figure 15: Airflow Through the EX3200 Switch Chassis

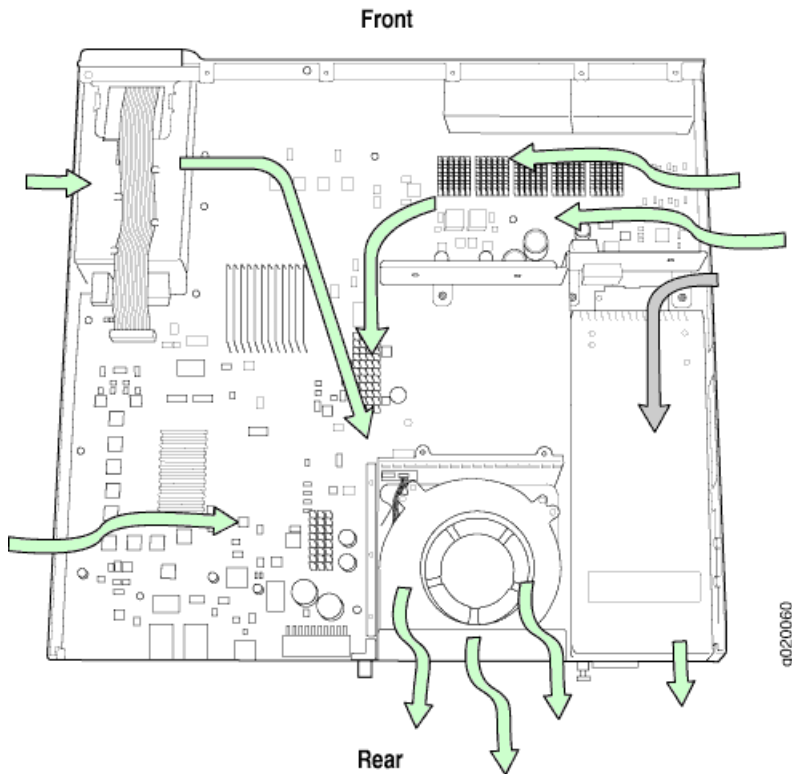

Temperature sensors in the chassis monitor the temperature within the chassis. The system raises an alarm if the fan fails or if the temperature inside the chassis rises above permitted levels. If the temperature inside the chassis rises above the threshold, the system shuts down automatically and the temperature shutdown LED on the rear panel is lit. You can see the status of fans and the temperature from the **Show Environment Status** option in the Status menu in the LCD panel.

RELATED DOCUMENTATION

[Clearance Requirements for Airflow and Hardware Maintenance for EX3200 Switches](#) | 64

EX3200 Power System

IN THIS SECTION

- [Power Supply in EX3200 Switches | 43](#)
- [AC Power Supply LEDs in EX3200 Switches | 47](#)
- [DC Power Supply LEDs in EX3200 Switches | 48](#)
- [Power Specifications for EX3200 Switches | 48](#)
- [AC Power Cord Specifications for EX3200 Switches | 50](#)

Power Supply in EX3200 Switches

IN THIS SECTION

- [AC Power Supplies | 44](#)
- [DC Power Supplies | 45](#)
- [PoE Power Budget and AC Power Supplies | 46](#)

The power supply in EX3200 switches is a field-replaceable unit (FRU) that you can install on the rear panel. The power supply in EX3200 switches is not redundant.

EX3200 switches use power supplies that provides two DC output voltages: 12 V for system and logic power and 48–51 V (or higher, to compensate for voltage drops along the path from the power supplies to the RJ-45 connector) for PoE ports.

NOTE: After powering on an the switch, wait for at least 60 seconds before powering it off. After powering off the switch, wait for at least 60 seconds before powering it back on.

After the switch is powered on, it can take up to 60 seconds for status indicators—such as LEDs on the power supply, **show chassis** command output, and messages on the LCD panel—to indicate that the power supply is functioning normally. Ignore error indicators that appear during the first 60 seconds.

AC Power Supplies

All the EX4200 switches that are powered by AC power supplies except the EX4200-24F-S and EX4200-48T-S switches are shipped with one AC power supply pre-installed in the rear panel of the switches. EX4200-24F-S and EX4200-48T-S switches are not shipped with pre-installed power supplies; you must order them separately.

The AC power supply for the switch is available in 320 W, 600 W, and 930 W models (see [Figure 16 on page 44](#) and [Figure 17 on page 45](#)). The exterior of the 600 W model is identical in appearance to that of the 930 W model. The 320 W power supply is flush with the chassis. The 600 W power supply and 930 W power supply extend out of the chassis by 2.25 in. The power cord retainer clips extend out of the power supply by 3 in. The number of ports on which PoE is enabled determines the minimum power requirements of different switch models.

Figure 16: 320 W AC Power Supply

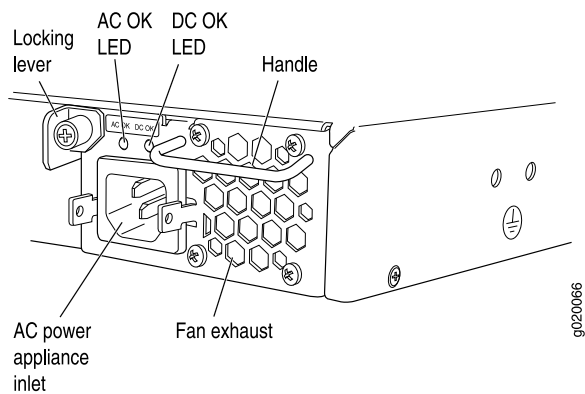
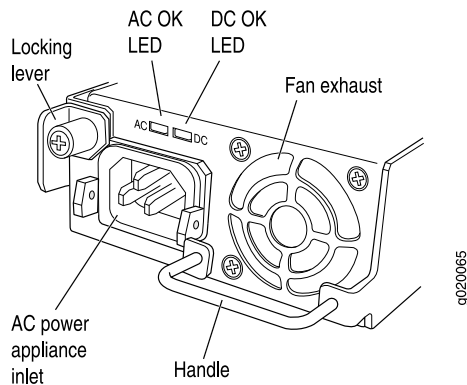

Figure 17: 600 W and 930 W AC Power Supplies



To avoid electrical injury, follow instructions in [“Installing a Power Supply in an EX3200 Switch” on page 176](#) and [“Removing a Power Supply from an EX3200 Switch” on page 175](#) or [Installing a Power Supply in an EX4200 Switch](#) or [Removing a Power Supply from an EX4200 Switch](#) carefully.

DC Power Supplies

All the EX4200 switches that are powered by DC power supplies except the EX4200-24F-S and EX4200-48T-S switches are shipped with one DC power supply pre-installed in the rear panel of the switches. EX4200-24F-S and EX4200-48T-S switches are not shipped with pre-installed power supplies; you must order them separately.

The DC power supply for the switch is available in a 190 W model, with dual input feeds for power resiliency (see [Figure 18 on page 46](#)).

NOTE: The DC power supply in the switch does not support Power over Ethernet (PoE); you can use either an external power injector or an AC power supply to supply power to PoE devices that you connect to the switch.

NOTE: The DC power supply in the switch has four terminals labeled A+, B+, A-, and B- (see [Figure 18 on page 46](#)) for connecting DC power source cables labeled positive (+) and negative (-). The DC power supplies are shipped with jumpers from A+ input to B+ input tied together and jumpers from A- input to B- input tied together.

NOTE: The A+ and B+ terminals are referred to as +RTN and A- and B- terminals are referred to as -48 V in “[DC Power Wiring Sequence Warning](#)” on page 272 and “[DC Power Electrical Safety Guidelines](#)” on page 267.

Figure 18: DC Power Supply

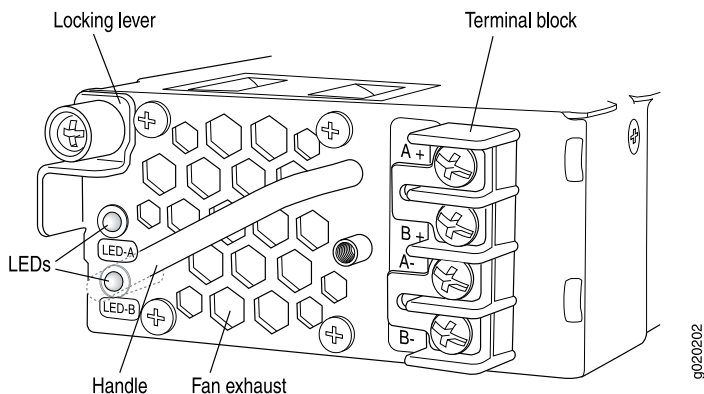

To avoid electrical injury, follow instructions in “[Installing a Power Supply in an EX3200 Switch](#)” on page 176 and “[Removing a Power Supply from an EX3200 Switch](#)” on page 175 or [Installing a Power Supply in an EX4200 Switch](#) or [Removing a Power Supply from an EX4200 Switch](#) carefully.

PoE Power Budget and AC Power Supplies

The PoE power budget for a PoE switch model is determined by the capacity of its power supply. For EX3200 switches, the capacity of the power supply provided with a PoE model is sufficient to supply each PoE-capable port with up to 15.4 W in compliance with the IEEE 802.3af PoE standard. [Table 11 on page 47](#) lists the EX3200 switch PoE models, their power supply ratings, and the associated PoE power budgets.

Starting with Junos OS Release 11.1, EX3200 switches support enhanced PoE, a Juniper Networks extension to the IEEE 302.3af PoE standard. Enhanced PoE permits up to 18.6 W per PoE port. Because the power supply provided with a switch is designed to supply a maximum of 15.4 W per PoE port, if you connect a powered device that draws more than 15.4 W, the PoE power budget might not be sufficient to supply a full 15.4 W to the remaining PoE ports.

NOTE: Switches upgraded to Junos OS Release 11.1 from a previous release require a separate upgrade of the PoE controller software to enable enhanced PoE support.

Table 11: Power Supply Rating and PoE Power Budget for EX3200 Switch Models

Switch Model Number	Number of PoE-enabled Ports	Power Supply Rating	PoE Power Budget
EX3200-24T	8	320 W	130 W
EX3200-48T	8	320 W	130 W
EX3200-24P	24	600 W	410 W
EX3200-48P	48	930 W	740 W

SEE ALSO

[Connecting AC Power to an EX3200 Switch | 114](#)
[Connecting DC Power to an EX3200 Switch | 117](#)

AC Power Supply LEDs in EX3200 Switches

Table 12 on page 47 describes the LEDs on the AC power supplies.

Table 12: AC Power Supply LEDs

LED	State and Description
AC OK	<ul style="list-style-type: none"> Off—Disconnected from power or power is not coming into the power supply. On—Power is coming into the power supply.
DC OK	<ul style="list-style-type: none"> Off—Power supply is not sending out power correctly. On—Power supply is sending out power correctly.

NOTE: If the **AC OK** LED and the **DC OK** LED are unlit, either the AC power cord is not installed properly or the power supply fuse has failed. If the **AC OK** LED is lit and the **DC OK** LED is unlit, the AC power supply is not installed properly or the power supply has an internal failure.

DC Power Supply LEDs in EX3200 Switches

. [Table 13 on page 48](#) describes the LEDs on the DC power supplies.

Table 13: DC Power Supply LEDs

LED Label	Color	Description
LED A	Red	Inputs A and B are normal, but there is no output.
LED B	Red	
LED A	Green	Inputs A and B are normal; output is normal.
LED B	Green	
LED A	Flash Red	Input A has failed because the power supply fuse has failed, input voltage is low, or there is a loose connection; output is normal.
LED B	Green	
LED A	Green	Input B has failed because the power supply fuse has failed, input voltage is low, or there is a loose connection; output is normal.
LED B	Flash Red	
LED A	Flash Red	Both inputs have failed because the power supply fuse has failed, input voltage is low, or there is a loose connection; output is normal.
LED B	Flash Red	
LED A	Off	There is no input; there is no output.
LED B	Off	

Power Specifications for EX3200 Switches

This topic describes power specifications for power supplies for EX3200 switches.

[Table 14 on page 49](#) provides the AC power supply electrical specifications for EX3200 switches.

[Table 15 on page 49](#) provides the DC power supply electrical specifications for EX3200 switches.

Table 14: AC Power Supply Electrical Specifications

Item	Specification
AC input voltage	100 through 240 VAC
AC input line frequency	50 through 60 Hz
AC system current rating	<ul style="list-style-type: none"> • 4 A (for switches with 8 ports equipped for Power over Ethernet (PoE) or the switch with 24 100Base-FX/1000Base-SX SFP ports) • 7 A (for switches with 24 ports equipped for PoE) • 12 A (for switches with 48 ports equipped for PoE)

Table 15: DC Power Supply Electrical Specifications

Item	Specification
DC input voltage	36 through 72 VDC
DC input current	7 A maximum
Power supply output	190 W
Output holdup time	1 ms minimum

NOTE: The DC power supply in EX3200 switches does not support Power over Ethernet (PoE); you can use either an external power injector or an AC power supply to supply power to PoE devices that you connect to the switch.

NOTE: For DC power supplies, we recommend that you provide at least 7.5 A @ 48 VDC and use a facility circuit breaker rated for 10 A minimum. Doing so enables you to operate the switch in any configuration without upgrading the power infrastructure, and allows the switch to function at full capacity using multiple power supplies.

AC Power Cord Specifications for EX3200 Switches

A detachable AC power cord is supplied with the AC power supplies. The coupler is type C13 as described by International Electrotechnical Commission (IEC) standard 60320. The plug at the male end of the power cord fits into the power source outlet that is standard for your geographical location.



CAUTION: The AC power cord provided with each power supply is intended for use with that power supply only and not for any other use.

NOTE: In North America, AC power cords must not exceed 4.5 meters in length, to comply with National Electrical Code (NEC) Sections 400-8 (NFPA 75, 5-2.2) and 210-52 and Canadian Electrical Code (CEC) Section 4-010(3). The cords supplied with the switch are in compliance.

Table 16 on page 50 gives the AC power cord specifications for the countries and regions listed in the table.

Table 16: AC Power Cord Specifications

Country/Region	Electrical Specifications	Plug Standards	Juniper Model Number
Argentina	250 VAC, 10 A, 50 Hz	IRAM 2073 Type RA/3	CBL-EX-PWR-C13-AR
Australia	250 VAC, 10 A, 50 Hz	AS/NZS 3112 Type SAA/3	CBL-EX-PWR-C13-AU
Brazil	250 VAC, 10 A, 50 Hz	NBR 14136 Type BR/3	CBL-EX-PWR-C13-BR
China	250 VAC, 10 A, 50 Hz	GB 1002-1996 Type PRC/3	CBL-EX-PWR-C13-CH
Europe (except Italy, Switzerland, and United Kingdom)	250 VAC, 10 A, 50 Hz	CEE (7) VII Type VIIG	CBL-EX-PWR-C13-EU
India	250 VAC, 10 A, 50 Hz	IS 1293 Type IND/3	CBL-EX-PWR-C13-IN
Israel	250 VAC, 10 A, 50 Hz	SI 32/1971 Type IL/3G	CBL-EX-PWR-C13-IL
Italy	250 VAC, 10 A, 50 Hz	CEI 23-16 Type I/3G	CBL-EX-PWR-C13-IT
Japan	125 VAC, 12 A, 50 Hz or 60 Hz	SS-00259 Type VCTF	CBL-EX-PWR-C13-JP

Table 16: AC Power Cord Specifications (continued)

Country/Region	Electrical Specifications	Plug Standards	Juniper Model Number
Korea	250 VAC, 10 A, 50 Hz or 60 Hz	CEE (7) VII Type VIIGK	CBL-EX-PWR-C13-KR
North America	125 VAC, 13 A, 60 Hz	NEMA 5-15 Type N5-15	CBL-EX-PWR-C13-US
South Africa	250 VAC, 10 A, 50 Hz	SABS 164/1:1992 Type ZA/13	CBL-EX-PWR-C13-SA
Switzerland	250 VAC, 10 A, 50 Hz	SEV 6534-2 Type 12G	CBL-EX-PWR-C13-SZ
Taiwan	125 VAC, 11 A and 15 A, 50 Hz	NEMA 5-15P Type N5-15P	CBL-EX-PWR-C13-TW
United Kingdom	250 VAC, 10 A, 50 Hz	BS 1363/A Type BS89/13	CBL-EX-PWR-C13-UK

Figure 19 on page 51 illustrates the plug on the power cord for some of the countries or regions listed in Table 16 on page 50.

Figure 19: AC Plug Types

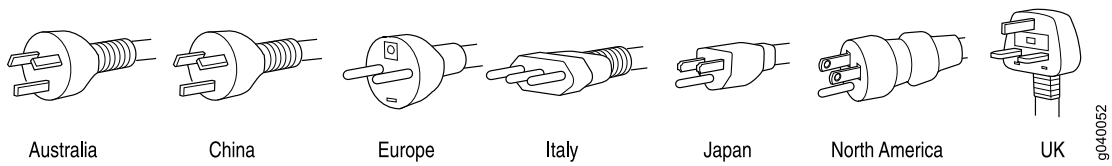

2

CHAPTER

Site Planning, Preparation, and Specifications

Site Preparation Checklist for EX3200 Switches | 53

EX3200 Site Guidelines and Requirements | 54

EX3200 Network Cable and Transceiver Planning | 65

EX3200 Management Cable Specifications and Pinouts | 73

Site Preparation Checklist for EX3200 Switches

The checklist in [Table 17 on page 53](#) summarizes the tasks you need to perform when preparing a site for EX3200 switch installation.

Table 17: Site Preparation Checklist

Item or Task	For More Information	Performed by	Date
Environment			
Verify that environmental factors such as temperature and humidity do not exceed switch tolerances.	"Environmental Requirements and Specifications for EX Series Switches" on page 55		
Power			
Measure distance between external power sources and switch installation site.			
Locate sites for connection of system grounding.			
Calculate the power consumption and requirements.	"Power Specifications for EX3200 Switches" on page 48		
Hardware Configuration			
Choose the number and types of switches you want to install.	"EX3200 Switches Hardware Overview" on page 19		
Rack or Cabinet			
Verify that your rack or cabinet meets the minimum requirements for the installation of the switch.	"Rack Requirements" on page 61 "Cabinet Requirements" on page 62		
Plan rack or cabinet location, including required space clearances.	"Clearance Requirements for Airflow and Hardware Maintenance for EX3200 Switches" on page 64		
Secure the rack or cabinet to the floor and building structure.			
Wall			

Table 17: Site Preparation Checklist (continued)

Item or Task	For More Information	Performed by	Date
Verify that the wall meets the minimum requirements for the installation of the switch.	“Requirements for Mounting an EX3200 Switch on a Desktop or Wall” on page 63		
Verify that there is appropriate clearance in your selected location.	“Clearance Requirements for Airflow and Hardware Maintenance for EX3200 Switches” on page 64		
Cables			
Acquire cables and connectors: <ul style="list-style-type: none"> • Determine the number of cables needed based on your planned configuration. • Review the maximum distance allowed for each cable. Choose the length of cable based on the distance between the hardware components being connected. 			
Plan the cable routing and management.			

EX3200 Site Guidelines and Requirements

IN THIS SECTION

- [Environmental Requirements and Specifications for EX Series Switches | 55](#)
- [General Site Guidelines | 60](#)
- [Site Electrical Wiring Guidelines | 60](#)
- [Rack Requirements | 61](#)
- [Cabinet Requirements | 62](#)
- [Requirements for Mounting an EX3200 Switch on a Desktop or Wall | 63](#)
- [Clearance Requirements for Airflow and Hardware Maintenance for EX3200 Switches | 64](#)

Environmental Requirements and Specifications for EX Series Switches

The switch must be installed in a rack or cabinet housed in a dry, clean, well-ventilated, and temperature-controlled environment.

Ensure that these environmental guidelines are followed:

- The site must be as dust-free as possible, because dust can clog air intake vents and filters, reducing the efficiency of the switch cooling system.
- Maintain ambient airflow for normal switch operation. If the airflow is blocked or restricted, or if the intake air is too warm, the switch might overheat, leading to the switch temperature monitor shutting down the switch to protect the hardware components.

Table 18 on page 55 provides the required environmental conditions for normal switch operation.

Table 18: EX Series Switch Environmental Tolerances

Switch or device	Environment Tolerance			
	Altitude	Relative Humidity	Temperature	Seismic
EX2200-C	No performance degradation up to 5,000 feet (1524 meters)	Normal operation ensured in the relative humidity range 10% through 85% (noncondensing)	Normal operation ensured in the temperature range 32° F (0° C) through 104° F (40° C) at altitudes up to 5,000 ft (1,524 m). For information about extended temperature SFP transceivers supported on EX2200 switches, see <i>Pluggable Transceivers Supported on EX2200 Switches</i> .	Complies with Zone 4 earthquake requirements as per GR-63, Issue 4.
EX2200 (except EX2200-C switches)	No performance degradation up to 10,000 feet (3048 meters)	Normal operation ensured in the relative humidity range 10% through 85% (noncondensing)	Normal operation ensured in the temperature range 32° F (0° C) through 113° F (45° C)	Complies with Zone 4 earthquake requirements as per GR-63, Issue 4.
EX2300-C	No performance degradation up to 5,000 feet (1524 meters)	Normal operation ensured in the relative humidity range 10% through 85% (noncondensing)	Normal operation ensured in the temperature range 32° F (0° C) through 104° F (40° C)	Complies with Zone 4 earthquake requirements as per GR-63, Issue 4.

Table 18: EX Series Switch Environmental Tolerances (continued)

Switch or device	Environment Tolerance			
	Altitude	Relative Humidity	Temperature	Seismic
EX2300 (except EX2300-C switches)	No performance degradation up to 13,000 feet (3962 meters) at 104° F (40° C) as per GR-63	Normal operation ensured in the relative humidity range 10% through 85% (noncondensing)	Normal operation ensured in the temperature range 32° F (0° C) through 113° F (45° C)	Complies with Zone 4 earthquake requirements as per GR-63, Issue 4.
EX3200	No performance degradation up to 10,000 feet (3048 meters)	Normal operation ensured in the relative humidity range 10% through 85% (noncondensing)	Normal operation ensured in the temperature range 32° F (0° C) through 113° F (45° C)	Complies with Zone 4 earthquake requirements as per GR-63, Issue 4.
EX3300	No performance degradation up to 10,000 feet (3048 meters)	Normal operation ensured in the relative humidity range 10% through 85% (noncondensing)	Normal operation ensured in the temperature range 32° F (0° C) through 113° F (45° C)	Complies with Zone 4 earthquake requirements as per GR-63, Issue 4.
EX3400	No performance degradation up to 10,000 feet (3048 meters)	Normal operation ensured in the relative humidity range 10% through 85% (noncondensing)	Normal operation ensured in the temperature range 32° F (0° C) through 113° F (45° C)	Complies with Zone 4 earthquake requirements as per GR-63, Issue 4.
EX4200	No performance degradation up to 10,000 feet (3048 meters)	Normal operation ensured in the relative humidity range 10% through 85% (noncondensing)	Normal operation ensured in the temperature range 32° F (0° C) through 113° F (45° C)	Complies with Zone 4 earthquake requirements as per GR-63, Issue 4.

Table 18: EX Series Switch Environmental Tolerances (continued)

Switch or device	Environment Tolerance			
	Altitude	Relative Humidity	Temperature	Seismic
EX4300 The maximum thermal output for EX4300-48T is 423 BTU/hour and for EX4300-48P is 5844 BTU/hour.	EX4300 switches except the EX4300-48MP model— No performance degradation up to 10,000 feet (3048 meters) EX4300-48MP model— No performance degradation up to 6,000 feet (1829 meters)	EX4300 switches except the EX4300-48MP model— Normal operation ensured in the relative humidity range 10% through 85% (noncondensing) EX4300-48MP model— Normal operation ensured in the relative humidity range 5% through 90% (noncondensing)	Normal operation ensured in the temperature range 32° F (0° C) through 113° F (45° C)	Complies with Zone 4 earthquake requirements as per GR-63, Issue 4.
EX4500	No performance degradation up to 10,000 feet (3048 meters)	Normal operation ensured in the relative humidity range 10% through 85% (noncondensing)	Normal operation ensured in the temperature range 32° F (0° C) through 113° F (45° C)	Complies with Zone 4 earthquake requirements as per GR-63, Issue 4.
EX4550	No performance degradation up to 10,000 feet (3048 meters)	Normal operation ensured in the relative humidity range 10% through 85% (noncondensing)	<ul style="list-style-type: none"> • EX4550-32F switches— Normal operation ensured in the temperature range 32° F (0° C) through 113° F (45° C) • EX4550-32T switches— Normal operation is ensured in the temperature range 32° F through 104° F (40° C) 	Complies with Zone 4 earthquake requirements as per GR-63, Issue 4.

Table 18: EX Series Switch Environmental Tolerances (continued)

Switch or device	Environment Tolerance			
	Altitude	Relative Humidity	Temperature	Seismic
EX4600	No performance degradation to 6,562 feet (2000 meters)	<p>Normal operation ensured in the relative humidity range 5% through 90%, noncondensing</p> <ul style="list-style-type: none"> Short-term operation ensured in the relative humidity range 5% through 93%, noncondensing <p>NOTE: As defined in NEBS GR-63-CORE, Issue 4, short-term events can be up to 96 hours in duration but not more than 15 days per year.</p>	<ul style="list-style-type: none"> Normal operation ensured in the temperature range 32° F (0° C) through 113° F (45° C) Nonoperating storage temperature in shipping container: - 40° F (-40° C) through 158° F (70° C) 	Complies with Zone 4 earthquake requirements per NEBS GR-63-CORE, Issue 4.
EX4650	No performance degradation to 6,000 feet (1829 meters)	Normal operation ensured in the relative humidity range 10% through 85% (condensing)	Normal operation is ensured in the temperature range 32° F (0° C) through 104° F (40° C)	Complies with Zone 4 earthquake requirements as per GR-63, Issue 4.
EX6210	No performance degradation up to 10,000 feet (3048 meters)	Normal operation ensured in the relative humidity range 10% through 85% (noncondensing)	Normal operation is ensured in the temperature range 32° F (0° C) through 104° F (40° C)	Complies with Zone 4 earthquake requirements as per GR-63, Issue 4.
EX8208	No performance degradation up to 10,000 feet (3048 meters)	Normal operation ensured in the relative humidity range 10% through 85% (noncondensing)	Normal operation is ensured in the temperature range 32° F (0° C) through 104° F (40° C)	Complies with Zone 4 earthquake requirements as per GR-63, Issue 4.
EX8216	No performance degradation up to 10,000 feet (3048 meters)	Normal operation ensured in the relative humidity range 10% through 85% (noncondensing)	Normal operation is ensured in the temperature range 32° F (0° C) through 104° F (40° C)	Complies with Zone 4 earthquake requirements as per GR-63, Issue 4.

Table 18: EX Series Switch Environmental Tolerances (continued)

Switch or device	Environment Tolerance			
	Altitude	Relative Humidity	Temperature	Seismic
EX9204	No performance degradation up to 10,000 feet (3048 meters)	Normal operation ensured in the relative humidity range 5% through 90% (noncondensing)	Normal operation is ensured in the temperature range 32° F (0° C) through 104° F (40° C) Nonoperating storage temperature in shipping container: - 40° F (-40° C) to 158° F (70° C)	Complies with Zone 4 earthquake requirements as per GR-63.
EX9208	No performance degradation up to 10,000 feet (3048 meters)	Normal operation ensured in the relative humidity range 5% through 90% (noncondensing)	Normal operation is ensured in the temperature range 32° F (0° C) through 104° F (40° C) Nonoperating storage temperature in shipping container: - 40° F (-40° C) to 158° F (70° C)	Complies with Zone 4 earthquake requirements as per GR-63.
EX9214	No performance degradation up to 10,000 feet (3048 meters)	Normal operation ensured in the relative humidity range 5% through 90% (noncondensing)	Normal operation is ensured in the temperature range 32° F (0° C) through 104° F (40° C) Nonoperating storage temperature in shipping container: - 40° F (-40° C) through 158° F (70° C)	Complies with Zone 4 earthquake requirements as per GR-63.
EX9251 The maximum thermal output is 1705 BTU/hour (500 W).	No performance degradation up to 10,000 ft (3048 m)	Normal operation ensured in relative humidity range of 5% to 90%, noncondensing	Normal operation ensured in temperature range of 32° F (0° C) to 104° F (40° C) Nonoperating storage temperature in shipping container: - 40° F (-40° C) to 158° F (70° C)	Complies with Telcordia Technologies Zone 4 earthquake requirements

Table 18: EX Series Switch Environmental Tolerances (*continued*)

Switch or device	Environment Tolerance			
	Altitude	Relative Humidity	Temperature	Seismic
XRE200	No performance degradation up to 10,000 feet (3048 meters)	Normal operation ensured in the relative humidity range 10% through 85% (noncondensing)	Normal operation ensured in the temperature range 41° F (5° C) through 104° F (40° C)	Complies with Zone 4 earthquake requirements as per GR-63, Issue 4.

NOTE: Install EX Series switches only in restricted areas, such as dedicated equipment rooms and equipment closets, in accordance with Articles 110- 16, 110- 17, and 110- 18 of the National Electrical Code, ANSI/NFPA 70.

General Site Guidelines

Efficient device operation requires proper site planning and maintenance and proper layout of the equipment, rack or cabinet (if used), and wiring closet.

To plan and create an acceptable operating environment for your device and prevent environmentally caused equipment failures:

- Keep the area around the chassis free from dust and conductive material, such as metal flakes.
- Follow prescribed airflow guidelines to ensure that the cooling system functions properly and that exhaust from other equipment does not blow into the intake vents of the device.
- Follow the prescribed electrostatic discharge (ESD) prevention procedures to prevent damaging the equipment. Static discharge can cause components to fail completely or intermittently over time.
- Install the device in a secure area, so that only authorized personnel can access the device.

Site Electrical Wiring Guidelines

Table 19 on page 61 describes the factors you must consider while planning the electrical wiring at your site.



WARNING: You must provide a properly grounded and shielded environment and use electrical surge-suppression devices.

Avertissement Vous devez établir un environnement protégé et convenablement mis à la terre et utiliser des dispositifs de parasurtension.

Table 19: Site Electrical Wiring Guidelines

Site Wiring Factor	Guidelines
Signaling limitations	<p>If your site experiences any of the following problems, consult experts in electrical surge suppression and shielding:</p> <ul style="list-style-type: none"> • Improperly installed wires cause radio frequency interference (RFI). • Damage from lightning strikes occurs when wires exceed recommended distances or pass between buildings. • Electromagnetic pulses (EMPs) caused by lightning damage unshielded conductors and electronic devices.
Radio frequency interference	<p>To reduce or eliminate RFI from your site wiring, do the following:</p> <ul style="list-style-type: none"> • Use a twisted-pair cable with a good distribution of grounding conductors. • If you must exceed the recommended distances, use a high-quality twisted-pair cable with one ground conductor for each data signal when applicable.
Electromagnetic compatibility	<p>If your site is susceptible to problems with electromagnetic compatibility (EMC), particularly from lightning or radio transmitters, seek expert advice.</p> <p>Some of the problems caused by strong sources of electromagnetic interference (EMI) are:</p> <ul style="list-style-type: none"> • Destruction of the signal drivers and receivers in the device • Electrical hazards as a result of power surges conducted over the lines into the equipment

Rack Requirements

You can mount the device on two-post racks or four-post racks.

Rack requirements consist of:

- Rack type
- Mounting bracket hole spacing

- Rack size and strength
- Rack connection to the building structure

Table 20 on page 62 provides the rack requirements and specifications.

Table 20: Rack Requirements and Specifications

Rack Requirement	Guidelines
Rack type	<p>You can mount the device on a rack that provides bracket holes or hole patterns spaced at 1-U (1.75 in. or 4.45 cm) increments and meets the size and strength requirements to support the weight.</p> <p>A U is the standard rack unit defined by the Electronic Components Industry Association (http://www.ecianow.org).</p>
Mounting bracket hole spacing	The holes in the mounting brackets are spaced at 1-U (1.75 in. or 4.45 cm), so that the device can be mounted in any rack that provides holes spaced at that distance.
Rack size and strength	<ul style="list-style-type: none"> • Ensure that the rack complies with the size and strength standards of a 19-in. rack as defined by the Electronic Components Industry Association (http://www.ecianow.org). • Ensure that the rack rails are spaced widely enough to accommodate the external dimensions of the device chassis. The outer edges of the front mounting brackets extend the width of the chassis to 19 in. (48.2 cm). • The rack must be strong enough to support the weight of the device. • Ensure that the spacing of rails and adjacent racks provides for proper clearance around the device and rack.
Rack connection to building structure	<ul style="list-style-type: none"> • Secure the rack to the building structure. • If your geographical area is earthquake-prone, secure the rack to the floor. • Secure the rack to the ceiling brackets as well as wall or floor brackets for maximum stability.

SEE ALSO

| [Rack-Mounting and Cabinet-Mounting Warnings](#) | 241

Cabinet Requirements

You can mount the device in a cabinet that contains a 19-in. rack.

Cabinet requirements consist of:

- Cabinet size
- Clearance requirements
- Cabinet airflow requirements

Table 21 on page 63 provides the cabinet requirements and specifications.

Table 21: Cabinet Requirements and Specifications

Cabinet Requirement	Guidelines
Cabinet size	<ul style="list-style-type: none"> • The minimum cabinet size is 36 in. (91.4 cm) depth. Large cabinets improve airflow and reduce chances of overheating.
Cabinet clearance	<ul style="list-style-type: none"> • The outer edges of the front mounting brackets extend the width of the chassis to 19 in. (48.2 cm). • The minimum total clearance inside the cabinet is 30.7 in. (78 cm) between the inside of the front door and the inside of the rear door.
Cabinet airflow requirements	<p>When you mount the device in a cabinet, ensure that ventilation through the cabinet is sufficient to prevent overheating.</p> <ul style="list-style-type: none"> • Ensure adequate cool air supply to dissipate the thermal output of the device or devices. • Ensure that the hot air exhaust of the chassis exits the cabinet without recirculating into the device. An open cabinet (without a top or doors) that employs hot air exhaust extraction from the top ensures the best airflow through the chassis. If the cabinet contains a top or doors, perforations in these elements assist with removing the hot air exhaust. • Install the device in the cabinet in a way that maximizes the open space on the side of the chassis that has the hot air exhaust. • Route and dress all cables to minimize the blockage of airflow to and from the chassis. • Ensure that the spacing of rails and adjacent cabinets is such that there is proper clearance around the device and cabinet. • A cabinet larger than the minimum required provides better airflow and reduces the chance of overheating.

Requirements for Mounting an EX3200 Switch on a Desktop or Wall

You can install the switch on or under a desk or other level surface or on a wall. When choosing a location, allow at least 6 in. (15.2 cm) of clearance between the front and back of the chassis and adjacent equipment or walls.

Ensure that the wall onto which the switch is installed is stable and securely supported.

If you are mounting the switch in sheetrock (wall board with a gypsum plaster core) or in wall board not backed by wall studs, use hollow wall anchors capable of supporting the combined weight of two fully loaded chassis. Insert the screws into wall studs wherever possible to provide added support for the chassis.

Use the wall-mount kit from Juniper Networks to mount the switch on a wall. The wall-mount kit is not part of the standard package and must be ordered separately.

SEE ALSO

[Mounting an EX3200 Switch on a Wall | 104](#)

Clearance Requirements for Airflow and Hardware Maintenance for EX3200 Switches

When planning the site for installing an EX3200 switch, you must allow sufficient clearance around the installed switch (see [Figure 20 on page 64](#)).

For the cooling system to function properly, the airflow around the chassis must be unrestricted. [Figure 21 on page 65](#) shows the airflow through the EX3200 switch chassis .

Figure 20: Clearance Requirements for Airflow and Hardware Maintenance for EX3200 Switches

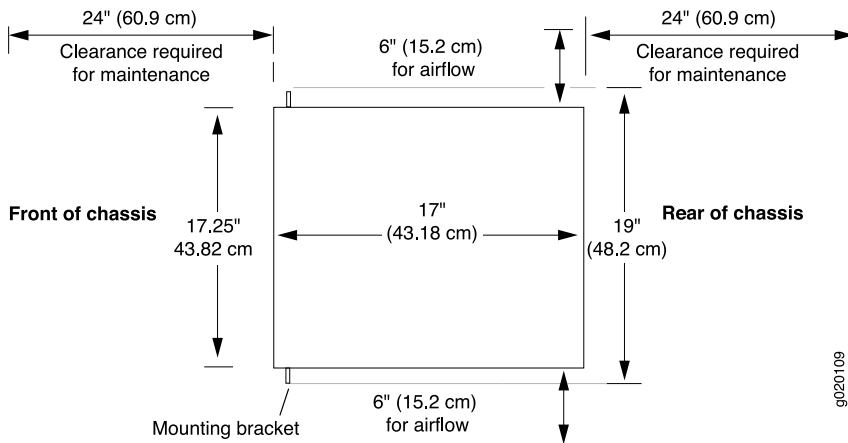
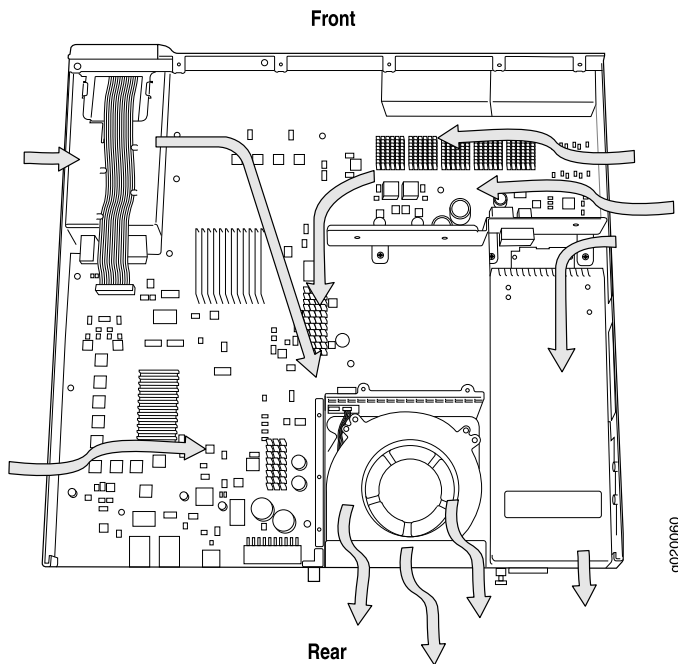

Figure 21: Airflow Through the EX3200 Switch Chassis



- Allow at least 6 in. (15.2 cm) of clearance on the side between devices that have fans or blowers installed. Allow 2.8 in. (7 cm) between the side of the chassis and any non-heat-producing surface such as a wall.
- If you are mounting the switch on a rack or cabinet with other equipment, or if you are placing it on the desktop or floor near other equipment, ensure that the exhaust from other equipment does not blow into the intake vents of the chassis.
- Leave at least 24 in. (61 cm) both in front of and behind the switch. For service personnel to remove and install hardware components, you must leave adequate space at the front and back of the switch. NEBS GR-63 recommends at least 30 in. (76.2 cm) in front of the rack or cabinet and 24 in. (61 cm) behind the rack or cabinet.

EX3200 Network Cable and Transceiver Planning

IN THIS SECTION

- [Pluggable Transceivers Supported on EX3200 Switches | 66](#)
- [SFP+ Direct Attach Copper Cables for EX Series Switches | 67](#)
- [Understanding EX Series Switches Fiber-Optic Cable Signal Loss, Attenuation, and Dispersion | 69](#)

- [Calculating the Fiber-Optic Cable Power Budget for EX Series Devices | 70](#)
- [Calculating the Fiber-Optic Cable Power Margin for EX Series Devices | 71](#)

Pluggable Transceivers Supported on EX3200 Switches

Optional uplink modules for EX3200 switches support SFP, SFP+, or XFP transceivers. You can find the list of transceivers supported on EX3200 switches and information about those transceivers at the [Hardware Compatibility Tool page for EX3200](#).

NOTE: We recommend that you use only optical transceivers and optical connectors purchased from Juniper Networks with your Juniper Networks device.



CAUTION: If you face a problem running a Juniper Networks device that uses a third-party optic or cable, the Juniper Networks Technical Assistance Center (JTAC) can help you diagnose the source of the problem. Your JTAC engineer might recommend that you check the third-party optic or cable and potentially replace it with an equivalent Juniper Networks optic or cable that is qualified for the device.

The Gigabit Ethernet SFP, SFP+, or XFP transceivers installed in EX3200 switches support digital optical monitoring (DOM): You can view the diagnostic details for these transceivers by issuing the operational mode CLI command **show interfaces diagnostics optics**.

SEE ALSO

[Uplink Modules in EX3200 Switches | 29](#)

SFP+ Direct Attach Copper Cables for EX Series Switches

IN THIS SECTION

- [Cable Specifications | 67](#)
- [List of DAC Cables Supported on EX Series Switches | 68](#)
- [Standards Supported by These Cables | 68](#)

Small form-factor pluggable plus transceiver (SFP+) direct attach copper (DAC) cables, also known as Twinax cables, are suitable for in-rack connections between servers and switches. They are suitable for short distances, making them ideal for highly cost-effective networking connectivity within a rack and between adjacent racks.

NOTE: We recommend that you use only SFP+ DAC cables purchased from Juniper Networks with your Juniper Networks device.



CAUTION: If you face a problem running a Juniper Networks device that uses a third-party optic or cable, the Juniper Networks Technical Assistance Center (JTAC) can help you diagnose the source of the problem. Your JTAC engineer might recommend that you check the third-party optic or cable and potentially replace it with an equivalent Juniper Networks optic or cable that is qualified for the device.

Cable Specifications

EX Series switches support SFP+ passive DAC cables. The passive Twinax cable is a straight cable with no active electronic components. EX Series switches support 1 m, 3 m, 5 m, and 7 m long SFP+ passive DAC cables. See [Figure 22 on page 68](#).

Figure 22: SFP+ Direct Attach Copper Cables for EX Series Switches

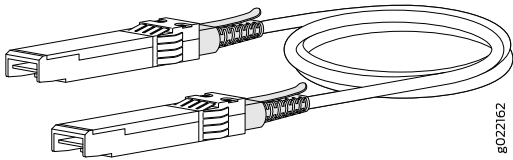

The cables are hot-removable and hot-insertable: You can remove and replace them without powering off the switch or disrupting switch functions. A cable comprises a low-voltage cable assembly that connects directly into two 10-Gigabit Ethernet ports, one at each end of the cable. The cables use high-performance integrated duplex serial data links for bidirectional communication and are designed for data rates of up to 10 Gbps.

List of DAC Cables Supported on EX Series Switches

For the list of DAC cables supported on EX Series switches and the specifications of these cables, see:

- EX2300—[Hardware Compatibility Tool page for EX2300](#)
- EX3200—[Hardware Compatibility Tool page for EX3200](#)
- EX3300—[Hardware Compatibility Tool page for EX3300](#)
- EX3400—[Hardware Compatibility Tool page for EX3400](#)
- EX4200—[Hardware Compatibility Tool page for EX4200](#)
- EX4300—[Hardware Compatibility Tool page for EX4300](#)
- EX4500—[Hardware Compatibility Tool page for EX4500](#)
- EX4550—[Hardware Compatibility Tool page for EX4550](#)
- EX4600—[Hardware Compatibility Tool page for EX4600](#)
- EX8208—[Hardware Compatibility Tool page for EX8208](#)
- EX8216—[Hardware Compatibility Tool page for EX8216](#)
- EX9251—[Hardware Compatibility Tool page for EX9251](#)
- EX9253—[Hardware Compatibility Tool page for EX9253](#)

Standards Supported by These Cables

The cables comply with the following standards:

- SFP mechanical standard SFF-843— see <ftp://ftp.seagate.com/sff/SFF-8431.PDF>.
- Electrical interface standard SFF-8432— see <ftp://ftp.seagate.com/sff/SFF-8432.PDF>.

- SFP+ Multi-Source Alliance (MSA) standards

Understanding EX Series Switches Fiber-Optic Cable Signal Loss, Attenuation, and Dispersion

IN THIS SECTION

- [Signal Loss in Multimode and Single-Mode Fiber-Optic Cable | 69](#)
- [Attenuation and Dispersion in Fiber-Optic Cable | 69](#)

To determine the power budget and power margin needed for fiber-optic connections, you need to understand how signal loss, attenuation, and dispersion affect transmission. EX Series switches use various types of network cable, including multimode and single-mode fiber-optic cable.

Signal Loss in Multimode and Single-Mode Fiber-Optic Cable

Multimode fiber is large enough in diameter to allow rays of light to reflect internally (bounce off the walls of the fiber). Interfaces with multimode optics typically use LEDs as light sources. However, LEDs are not coherent light sources. They spray varying wavelengths of light into the multimode fiber, which reflects the light at different angles. Light rays travel in jagged lines through a multimode fiber, causing signal dispersion. When light traveling in the fiber core radiates into the fiber cladding (layers of lower refractive index material in close contact with a core material of higher refractive index), higher-order mode loss (HOL) occurs. Together, these factors reduce the transmission distance of multimode fiber compared to that of single-mode fiber.

Single-mode fiber is so small in diameter that rays of light reflect internally through one layer only. Interfaces with single-mode optics use lasers as light sources. Lasers generate a single wavelength of light, which travels in a straight line through the single-mode fiber. Compared to multimode fiber, single-mode fiber has a higher bandwidth and can carry signals for longer distances. It is consequently more expensive.

Exceeding the maximum transmission distances can result in significant signal loss, which causes unreliable transmission.

Attenuation and Dispersion in Fiber-Optic Cable

An optical data link functions correctly provided that modulated light reaching the receiver has enough power to be demodulated correctly. *Attenuation* is the reduction in strength of the light signal during

transmission. Passive media components such as cables, cable splices, and connectors cause attenuation. Although attenuation is significantly lower for optical fiber than for other media, it still occurs in both multimode and single-mode transmission. An efficient optical data link must transmit enough light to overcome attenuation.

Dispersion is the spreading of the signal over time. The following two types of dispersion can affect signal transmission through an optical data link:

- Chromatic dispersion, which is the spreading of the signal over time caused by the different speeds of light rays.
- Modal dispersion, which is the spreading of the signal over time caused by the different propagation modes in the fiber.

For multimode transmission, modal dispersion, rather than chromatic dispersion or attenuation, usually limits the maximum bit rate and link length. For single-mode transmission, modal dispersion is not a factor. However, at higher bit rates and over longer distances, chromatic dispersion limits the maximum link length.

An efficient optical data link must have enough light to exceed the minimum power that the receiver requires to operate within its specifications. In addition, the total dispersion must be within the limits specified for the type of link in Telcordia Technologies document GR-253-CORE (Section 4.3) and International Telecommunications Union (ITU) document G.957.

When chromatic dispersion is at the maximum allowed, its effect can be considered as a power penalty in the power budget. The optical power budget must allow for the sum of component attenuation, power penalties (including those from dispersion), and a safety margin for unexpected losses.

Calculating the Fiber-Optic Cable Power Budget for EX Series Devices

To ensure that fiber-optic connections have sufficient power for correct operation, calculate the link's power budget when planning fiber-optic cable layout and distances to ensure that fiber-optic connections have sufficient power for correct operation. The power budget is the maximum amount of power the link can transmit. When you calculate the power budget, you use a worst-case analysis to provide a margin of error, even though all the parts of an actual system do not operate at the worst-case levels.

To calculate the worst-case estimate for fiber-optic cable power budget (P_B) for the link:

1. Determine values for the link's minimum transmitter power (P_T) and minimum receiver sensitivity (P_R). For example, here, (P_T) and (P_R) are measured in decibels, and decibels are referred to one milliwatt (dBm).

$$P_T = -15 \text{ dBm}$$

$$P_R = -28 \text{ dBm}$$

NOTE: See the specifications for your transmitter and receiver to find the minimum transmitter power and minimum receiver sensitivity.

- Calculate the power budget (P_B) by subtracting (P_R) from (P_T):

$$-15 \text{ dBm} - (-28 \text{ dBm}) = 13 \text{ dBm}$$

Calculating the Fiber-Optic Cable Power Margin for EX Series Devices

Calculate the link's power margin when planning fiber-optic cable layout and distances to ensure that fiber-optic connections have sufficient signal power to overcome system losses and still satisfy the minimum input requirements of the receiver for the required performance level. The power margin (P_M) is the amount of power available after attenuation or link loss (LL) has been subtracted from the power budget (P_B).

When you calculate the power margin, you use a worst-case analysis to provide a margin of error, even though all the parts of an actual system do not operate at worst-case levels. A power margin (P_M) greater than zero indicates that the power budget is sufficient to operate the receiver and that it does not exceed the maximum receiver input power. This means the link will work. A (P_M) that is zero or negative indicates insufficient power to operate the receiver. See the specification for your receiver to find the maximum receiver input power.

Before calculating the power margin:

- Calculate the power budget (see [“Calculating the Fiber-Optic Cable Power Budget for EX Series Devices” on page 70](#)).

To calculate the worst-case estimate for the power margin (P_M) for the link:

- Determine the maximum value for link loss (LL) by adding estimated values for applicable link-loss factors—for example, use the sample values for various factors as provided in [Table 22 on page 71](#) (here, the link is 2 km long and multimode, and the (P_B) is 13 dBm):

Table 22: Estimated Values for Factors Causing Link Loss

Link-Loss Factor	Estimated Link-Loss Value	Sample (LL) Calculation Values
Higher-order mode losses (HOL)	<ul style="list-style-type: none"> Multimode—0.5 dBm Single mode—None 	<ul style="list-style-type: none"> 0.5 dBm 0 dBm

Table 22: Estimated Values for Factors Causing Link Loss (*continued*)

Link-Loss Factor	Estimated Link-Loss Value	Sample (LL) Calculation Values
Modal and chromatic dispersion	<ul style="list-style-type: none"> • Multimode—None, if product of bandwidth and distance is less than 500 MHz/km • Single mode—None 	<ul style="list-style-type: none"> • 0 dBm • 0 dBm
Connector	0.5 dBm	This example assumes 5 connectors. Loss for 5 connectors: (5) * (0.5 dBm) = 2.5 dBm
Splice	0.5 dBm	This example assumes 2 splices. Loss for two splices: (2) * (0.5 dBm) = 1 dBm
Fiber attenuation	<ul style="list-style-type: none"> • Multimode—1 dBm/km • Single mode—0.5 dBm/km 	This example assumes the link is 2 km long. Fiber attenuation for 2 km: <ul style="list-style-type: none"> • (2 km) * (1.0 dBm/km) = 2 dBm • (2 km) * (0.5 dBm/km) = 1 dBm
Clock Recovery Module (CRM)	1 dBm	1 dBm

NOTE: For information about the actual amount of signal loss caused by equipment and other factors, see your vendor documentation for that equipment.

2. Calculate the (P_M) by subtracting (LL) from (P_B):

$$P_B - LL = P_M$$

$$(13 \text{ dBm}) - (0.5 \text{ dBm [HOL]}) - ((5) * (0.5 \text{ dBm})) - ((2) * (0.5 \text{ dBm})) - ((2 \text{ km}) * (1.0 \text{ dBm/km})) - (1 \text{ dB [CRM]}) = P_M$$

$$13 \text{ dBm} - 0.5 \text{ dBm} - 2.5 \text{ dBm} - 1 \text{ dBm} - 2 \text{ dBm} - 1 \text{ dBm} = P_M$$

$$P_M = 6 \text{ dBm}$$

The calculated power margin is greater than zero, indicating that the link has sufficient power for transmission. Also, the power margin value does not exceed the maximum receiver input power. Refer to the specification for your receiver to find the maximum receiver input power.

EX3200 Management Cable Specifications and Pinouts

IN THIS SECTION

- [Management Cable Specifications | 73](#)
- [Console Port Connector Pinout Information | 74](#)
- [USB Port Specifications for an EX Series Switch | 74](#)
- [RJ-45 Management Port Connector Pinout Information | 75](#)
- [RJ-45 Port, SFP Port, SFP+ Port, QSFP+ Port, and QSFP28 Port Connector Pinout Information | 76](#)
- [RJ-45 to DB-9 Serial Port Adapter Pinout Information | 80](#)
- [Uplink Modules Connector Pinout Information for EX3200 Switches | 81](#)

Management Cable Specifications

[Table 23 on page 73](#) lists the specifications for the cables that connect the console and management ports to management devices.

Table 23: Specifications of Cables to Connect to Management Devices

Ports	Cable Specifications	Receptacle	Additional Information
RJ-45 Console port	CAT5e UTP (unshielded twisted pair) cable	RJ-45	“Connect a Device to a Management Console Using an RJ-45 Connector” on page 121
Management Ethernet port	Ethernet cable with an RJ-45 connector	RJ-45	“Connect a Device to a Network for Out-of-Band Management” on page 121
Mini-USB Type-B Console port	Mini-USB cable with standard-A and Mini-USB Type-B (5-pin) connector	Mini-USB	

Console Port Connector Pinout Information

The console port on a Juniper Networks device is an RS-232 serial interface that uses an RJ-45 connector to connect to a console management device. The default baud rate for the console port is 9600 baud.

Table 24 on page 74 provides the pinout information for the RJ-45 console connector.

NOTE: If your laptop or desktop PC does not have a DB-9 plug connector pin and you want to connect your laptop or desktop PC directly to a device, use a combination of the RJ-45 to DB-9 socket adapter and a USB to DB-9 plug adapter. You must provide the USB to DB-9 plug adapter.

Table 24: Console Port Connector Pinout Information

Pin	Signal	Description
1	RTS Output	Request to send
2	DTR Output	Data terminal ready
3	TxD Output	Transmit data
4	Signal Ground	Signal ground
5	Signal Ground	Signal ground
6	RxD Input	Receive data
7	CD Input	Data carrier detect
8	NC	CTS Input

USB Port Specifications for an EX Series Switch

The following Juniper Networks USB flash drives have been tested and are officially supported for the USB port on all EX Series switches:

- RE-USB-1G-S
- RE-USB-2G-S
- RE-USB-4G-S



CAUTION: Any USB memory product not listed as supported for EX Series switches has not been tested by Juniper Networks. The use of any unsupported USB memory product could expose your EX Series switch to unpredictable behavior. Juniper Networks Technical Assistance Center (JTAC) can provide only limited support for issues related to unsupported hardware. We strongly recommend that you use only supported USB flash drives.

All USB flash drives used on EX Series switches must have the following features:

- USB 2.0 or later.
- Formatted with a FAT or MS-DOS file system.
- If the switch is running Junos OS Release 9.5 or earlier, the formatting method must use a primary boot record. Microsoft Windows formatting, by default, does not use a primary boot record. See the documentation for your USB flash drive for information about how your USB flash drive is formatted.

RJ-45 Management Port Connector Pinout Information

Table 25 on page 75 provides the pinout information for the RJ-45 connector for the management port on Juniper Networks devices.

Table 25: RJ-45 Management Port Connector Pinout Information

Pin	Signal	Description
1	TRP1+	Transmit/receive data pair 1
2	TRP1–	Transmit/receive data pair 1
3	TRP2+	Transmit/receive data pair 2
4	TRP3+	Transmit/receive data pair 3
5	TRP3–	Transmit/receive data pair 3
6	TRP2–	Transmit/receive data pair 2
7	TRP4+	Transmit/receive data pair 4
8	TRP4–	Transmit/receive data pair 4

RJ-45 Port, SFP Port, SFP+ Port, QSFP+ Port, and QSFP28 Port Connector Pinout Information

The tables in this topic describe the connector pinout information for the RJ-45, QSFP+, QSFP28, SFP+, and SFP ports.

- [Table 26 on page 76](#)—10/100/1000BASE-T Ethernet network port connector pinout information
- [Table 27 on page 76](#)—SFP network port connector pinout information
- [Table 28 on page 78](#)—SFP+ network port connector pinout information
- [Table 29 on page 79](#)—QSFP+ and QSFP28 network module ports connector pinout information

Table 26: 10/100/1000BASE-T Ethernet Network Port Connector Pinout Information

Pin	Signal	Description
1	TRP1+	Transmit/receive data pair 1 Negative Vport (in PoE models)
2	TRP1-	Transmit/receive data pair 1 Negative Vport (in PoE models)
3	TRP2+	Transmit/receive data pair 2 Positive Vport (in PoE models)
4	TRP3+	Transmit/receive data pair 3
5	TRP3-	Transmit/receive data pair 3
6	TRP2-	Transmit/receive data pair 2 Positive Vport (in PoE models)
7	TRP4+	Transmit/receive data pair 4
8	TRP4-	Transmit/receive data pair 4

Table 27: SFP Network Port Connector Pinout Information

Pin	Signal	Description
1	VeeT	Module transmitter ground

Table 27: SFP Network Port Connector Pinout Information (continued)

Pin	Signal	Description
2	TX_Fault	Module transmitter fault
3	TX_Disable	Transmitter disabled
4	SDA	2-wire serial interface data line
5	SCL-	2-wire serial interface clock
6	MOD_ABS	Module absent
7	RS	Rate select
8	RX_LOS	Receiver loss of signal indication
9	VeeR	Module receiver ground
10	VeeR	Module receiver ground
11	VeeR	Module receiver ground
12	RD-	Receiver inverted data output
13	RD+	Receiver noninverted data output
14	VeeR	Module receiver ground
15	VccR	Module receiver 3.3 V supply
16	VccT	Module transmitter 3.3 V supply
17	VeeT	Module transmitter ground
18	TD+	Transmitter noninverted data input
19	TD-	Transmitter inverted data input
20	VeeT	Module transmitter ground

Table 28: SFP+ Network Port Connector Pinout Information

Pin	Signal	Description
1	VeeT	Module transmitter ground
2	TX_Fault	Module transmitter fault
3	TX_Disable	Transmitter disabled
4	SDA	2-wire serial interface data line
5	SCL-	2-wire serial interface clock
6	MOD_ABS	Module absent
7	RS0	Rate select 0, optionally controls SFP+ module receiver
8	RX_LOS	Receiver loss of signal indication
9	RS1	Rate select 1, optionally controls SFP+ transmitter
10	VeeR	Module receiver ground
11	VeeR	Module receiver ground
12	RD-	Receiver inverted data output
13	RD+	Receiver noninverted data output
14	VeeR	Module receiver ground
15	VccR	Module receiver 3.3-V supply
16	VccT	Module transmitter 3.3-V supply
17	VeeT	Module transmitter ground
18	TD+	Transmitter noninverted data input
19	TD-	Transmitter inverted data input
20	VeeT	Module transmitter ground

Table 29: QSFP+ and QSFP28 Network Port Connector Pinout Information

Pin	Signal
1	GND
2	TX2n
3	TX2p
4	GND
5	TX4n
6	TX4p
7	GND
8	ModSelL
9	LPMoDe_Reset
10	VccRx
11	SCL
12	SDA
13	GND
14	RX3p
15	RX3n
16	GND
17	RX1p
18	RX1n
19	GND
20	GND
21	RX2n

Table 29: QSFP+ and QSFP28 Network Port Connector Pinout Information (continued)

Pin	Signal
22	RX2p
23	GND
24	RX4n
25	RX4p
26	GND
27	ModPrsL
28	IntL
29	VccTx
30	Vcc1
31	Reserved
32	GND
33	TX3p
34	TX3n
35	GND
36	TX1p
37	TX1n
38	GND

RJ-45 to DB-9 Serial Port Adapter Pinout Information

The console port is an RS-232 serial interface that uses an RJ-45 connector to connect to a management device such as a laptop or a desktop PC. If your laptop or desktop PC does not have a DB-9 plug connector

pin and you want to connect your laptop or desktop PC to the device, use a combination of the RJ-45 to DB-9 socket adapter along with a USB to DB-9 plug adapter.

[Table 30 on page 81](#) provides the pinout information for the RJ-45 to DB-9 serial port adapter.

Table 30: RJ-45 to DB-9 Serial Port Adapter Pinout Information

RJ-45 Pin	Signal	DB-9 Pin	Signal
1	RTS	8	CTS
2	DTR	6	DSR
3	TxD	2	RxD
4	GND	5	GND
6	RxD	3	TxD
7	DSR	4	DTR
8	CTS	7	RTS

Uplink Modules Connector Pinout Information for EX3200 Switches

EX3200 switches have a field-replaceable unit (FRU) uplink module on the front panel. [Table 31 on page 81](#) provides the uplink modules connector pinout information.

NOTE: You can use these ports to connect an access switch to a distribution switch.

Table 31: Uplink Modules Connector Pinout Information

Pin Number	Pin Name
A1	GND
A2	GND
A3	GND
A4	GND

Table 31: Uplink Modules Connector Pinout Information (continued)

Pin Number	Pin Name
A5	GND
A6	GND
A7	GND
A8	GND
A9	GND
A10	GND
A11	GND
A12	GND
A13	GND
A14	GND
A15	Uplink_I2C_SCK
A16	GND
A17	Uplink_PD
A18	GND
A19	POWER (12V)
A20	GND
B1	GND
B2	XAU10_RX0N
B3	GND
B4	XAU10_RX2N
B5	Uplink_P25_LED2

Table 31: Uplink Modules Connector Pinout Information (continued)

Pin Number	Pin Name
B6	XAUI1_RX0N
B7	Uplink_P27_LED2
B8	XAUI1_RX2N
B9	GND
B10	SRX28N
B11	Uplink_XAUI_XMDIO
B12	SRX26N
B13	GND
B14	SGMIIRXN
B15	Uplink_I2C_Rst
B16	Uplink_Intr
B17	Uplink_Pwr_En
B18	Uplink_P26_LED0
B19	POWER (12V)
B20	POWER (12V)
C1	GND
C2	XAUI0_RX0P
C3	GND
C4	XAUI0_RX2P
C5	GND
C6	XAUI1_RX0P

Table 31: Uplink Modules Connector Pinout Information (continued)

Pin Number	Pin Name
C7	GND
C8	XAUI1_RX2P
C9	GND
C10	SRX28P
C11	GND
C12	SRX26P
C13	GND
C14	SGMIIRXP
C15	CPU_UPLINK_MDC
C16	Uplink_I2C_SDA
C17	CPU_UPLINK_MDIO
C18	Uplink_P26_LED1
C19	UPLNK_PWR_OK
C20	POWER (12V)
D1	GND
D2	GND
D3	XAUI0_TX1N
D4	GND
D5	XAUI0_TX3N
D6	GND
D7	XAUI1_TX1N

Table 31: Uplink Modules Connector Pinout Information (continued)

Pin Number	Pin Name
D8	GND
D9	XAUI1_TX3N
D10	GND
D11	STX27N
D12	GND
D13	STX25N
D14	GND
D15	Uplink_Rst
D16	GND
D17	Uplink_Status_LED0
D18	GND
D19	POWER (12V)
D20	GND
E1	GND
E2	XAUI0_TX0N
E3	XAUI0_TX1P
E4	XAUI0_TX2N
E5	XAUI0_TX3P
E6	XAUI1_TX0N
E7	XAUI1_TX1P
E8	XAUI1_TX2N

Table 31: Uplink Modules Connector Pinout Information (continued)

Pin Number	Pin Name
E9	XAUI1_TX3P
E10	STX28N
E11	STX27P
E12	STX26N
E13	STX25P
E14	SGMIITXN
E15	Uplink_Hotswap_LED
E16	Uplink_Spare_Intr
E17	Uplink_Status_LED1
E18	Uplink_P27_LED0
E19	POWER (12V)
E20	POWER (12V)
F1	GND
F2	XAUI0_TX0P
F3	GND
F4	XAUI0_TX2P
F5	GND
F6	XAUI1_TX0P
F7	GND
F8	XAUI_TX2P
F9	GND

Table 31: Uplink Modules Connector Pinout Information (continued)

Pin Number	Pin Name
F10	STX28P
F11	GND
F12	STX26P
F13	GND
F14	SGMIITXP
F15	GND
F16	Uplink_Expander_Intr
F17	GND
F18	Uplink_P27_LED1
F19	GND
F20	POWER (12V)
G1	GND
G2	GND
G3	XAUI0_RX1N
G4	GND
G5	XAUI0_RX3N
G6	GND
G7	XAUI1_RX1N
G8	GND
G9	XAUI1_RX3N
G10	GND

Table 31: Uplink Modules Connector Pinout Information (continued)

Pin Number	Pin Name
G11	SRX27N
G12	GND
G13	SRX25N
G14	GND
G15	GND
G16	GND
G17	Uplink_P25_LED0
G18	GND
G19	POWER (12V)
G20	GND
H1	Uplink_PD_Loopback
H2	GND
H3	XAUI0_RX1P
H4	GND
H5	XAUI0_RX3P
H6	Uplink_P26_LED2
H7	XAUI1_RX1P
H8	Uplink_P28_LED2
H9	XAUI1_RX3P
H10	GND
H11	SRX27P

Table 31: Uplink Modules Connector Pinout Information (continued)

Pin Number	Pin Name
H12	Uplink_XAUI_MDC
H13	SRX25P
H14	GND
H15	Serial_RX
H16	GND
H17	Uplink_P25_LED1
H18	Uplink_P28_LED0
H19	POWER (12V)
H20	POWER (12V)
I1	GND
I2	GND
I3	GND
I4	GND
I5	GND
I6	GND
I7	GND
I8	GND
I9	GND
I10	GND
I11	GND
I12	GND

Table 31: Uplink Modules Connector Pinout Information (continued)

Pin Number	Pin Name
I13	GND
I14	GND
I15	GND
I16	Serial_TX
I17	GND
I18	Uplink_P28_LED1
I19	GND
I20	POWER (12V)

3

CHAPTER

Initial Installation and Configuration

Unpacking and Mounting the EX3200 Switch | **92**

Connecting the EX3200 to Power | **106**

Connecting the EX3200 to External Devices | **120**

Connecting the EX3200 to the Network | **123**

Configuring Junos OS on the EX3200 | **127**

Dashboard for EX Series Switches | **142**

Unpacking and Mounting the EX3200 Switch

IN THIS SECTION

- Unpacking an EX3200 Switch | 92
- Parts Inventory (Packing List) for an EX3200 Switch | 93
- Register Products—Mandatory to Validate SLAs | 95
- Installing and Connecting an EX3200 Switch | 95
- Mounting an EX3200 Switch | 96
- Mounting an EX3200 Switch on a Desk or Other Level Surface | 96
- Mounting an EX3200 Switch on Two Posts in a Rack or Cabinet | 98
- Mounting an EX3200 Switch on Four Posts in a Rack or Cabinet | 100
- Mounting an EX3200 Switch in a Recessed Position in a Rack or Cabinet | 104
- Mounting an EX3200 Switch on a Wall | 104

Unpacking an EX3200 Switch

The EX3200 switch chassis is a rigid sheet-metal structure that houses the hardware components. EX3200 switches are shipped in a cardboard carton, secured with foam packing material. The carton also contains an accessory box.



CAUTION: EX3200 switches are maximally protected inside the shipping carton. Do not unpack the switches until you are ready to begin installation.

To unpack the switch (see [Figure 23 on page 93](#)):

1. Move the shipping carton to a staging area as close to the installation site as possible, but where you have enough room to remove the system components.
2. Position the carton so that the arrows are pointing up.
3. Open the top flaps on the shipping carton.

4. Remove the accessory box and verify the contents in it against the parts inventory on the label attached to the carton.
5. Pull out the packing material holding the switch in place.
6. Verify the chassis components received against the packing list included with the switch. An inventory of parts provided with the switch is provided in [“Parts Inventory \(Packing List\) for an EX3200 Switch” on page 93](#).
7. Save the shipping carton and packing materials in case you need to move or ship the switch later.

Figure 23: Unpacking an EX3200 Switch

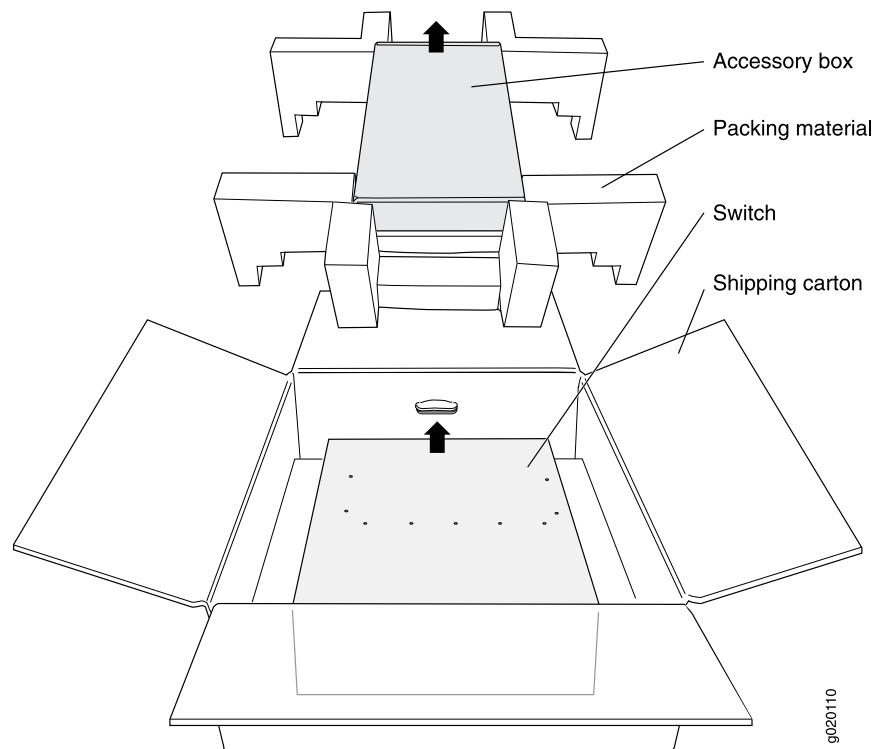

9020110

Parts Inventory (Packing List) for an EX3200 Switch

The EX3200 switches are shipped in a cardboard carton, secured with foam packing material. The carton contains an accessory box.

The switch shipment includes a packing list. Check the parts you receive in the switch shipping carton against the items on the packing list. The parts shipped depend on the configuration you order.

If any part on the packing list is missing, contact your customer service representative or contact Juniper customer care from within the U.S. or Canada by telephone at 1-888-314-5822. For international-dial or direct-dial options in countries without toll-free numbers, see <https://www.juniper.net/support/requesting-support.html>.

Table 32 on page 94 lists the parts and their quantities in the packing list.

Table 32: Packing List for an EX3200 Switch

Component	Quantity
Switch	1
Fan tray (preinstalled)	1
Power supply (preinstalled if your system order includes a 320 W AC power supply; not preinstalled if your system order includes a 600 W AC power supply, a 930 W AC power supply, or a 190 W DC power supply)	1
AC power cord appropriate for your geographical location (only for AC switch models)	1
Power cord retainer clip (only for AC switch models)	1
Mounting brackets	2
Mounting screws to attach the mounting brackets to the switch chassis	8
Rubber feet	4
RJ-45 cable and RJ-45 to DB-9 serial port adapter	1
Documentation Roadmap	1
Juniper Networks Product Warranty	1
End User License Agreement	1

NOTE: You must provide mounting screws that are appropriate for your rack or cabinet to mount the chassis on a rack or a cabinet.

Register Products—Mandatory to Validate SLAs

Register all new Juniper Networks hardware products and changes to an existing installed product using the Juniper Networks website to activate your hardware replacement service-level agreements (SLAs).



CAUTION: Register product serial numbers on the Juniper Networks website and update the installation base data if there is any addition or change to the installation base or if the installation base is moved. Juniper Networks will not be held accountable for not meeting the hardware replacement service-level agreement for products that do not have registered serial numbers or accurate installation base data.

Register your product(s) at <https://tools.juniper.net/svcreg/SRegSerialNum.jsp>.

Update your installation base at

<https://www.juniper.net/customers/csc/management/updateinstallbase.jsp>.

Installing and Connecting an EX3200 Switch

The EX3200 switch chassis is a rigid sheet-metal structure that houses the hardware components.

To install and connect an EX3200 switch:

1. Follow instructions in [“Unpacking an EX3200 Switch” on page 92](#).
2. Mount the switch by following instructions appropriate for your site:
 - [“Mounting an EX3200 Switch on Two Posts in a Rack or Cabinet” on page 98](#) (using the mounting brackets provided)
 - [“Mounting an EX3200 Switch on Four Posts in a Rack or Cabinet” on page 100](#) (using the separately orderable four-post rack-mount kit)
 - [“Mounting an EX3200 Switch in a Recessed Position in a Rack or Cabinet” on page 104](#) (using the 2-in.-recess front brackets from the separately orderable four-post rack-mount kit)
 - [“Mounting an EX3200 Switch on a Desk or Other Level Surface” on page 96](#) (using the rubber feet provided)
 - [“Mounting an EX3200 Switch on a Wall” on page 104](#) (using the separately orderable wall-mount kit)
3. Follow instructions in [“Connect Earth Ground to an EX Series Switch” on page 107](#).

4. Follow instructions for connecting power as appropriate for your site:
 - [Connecting AC Power to an EX3200 Switch on page 114](#)
 - [Connecting DC Power to an EX3200 Switch on page 117](#)
5. Perform initial configuration of the switch by following instructions in [“Connecting and Configuring an EX Series Switch \(CLI Procedure\)” on page 132](#) or [“Connecting and Configuring an EX Series Switch \(J-Web Procedure\)” on page 135](#).
6. Set the switch’s management options by following the appropriate instructions:
 - [Connect a Device to a Network for Out-of-Band Management on page 121](#)
 - [Connect a Device to a Management Console Using an RJ-45 Connector on page 121](#)

Mounting an EX3200 Switch

You can mount the switch:

- On two posts in a 19-in. rack or cabinet by using the mounting brackets provided with the switch.
- On four posts in a 19-in. rack or cabinet by using the separately orderable four-post rack-mount kit.
- In a position recessed 2 in. from the front of a 19-in. rack or cabinet by using the 2-in.-recess front brackets in the separately orderable four-post rack-mount kit. You can mount the switch in this recessed position on two-post or four-post racks and cabinets.
- On a desk or other level surface by using rubber feet. The switch is shipped with four rubber feet to be used to stabilize the chassis on a desk or other level surface.
- On a wall by using the separately orderable wall-mount kit.

The holes in the mounting brackets are placed at 1 U (1.75 in. or 4.45 cm.) apart so that the switch can be mounted in any rack or cabinet that provides holes spaced at that distance.

See the Related Documentation for detailed descriptions of the various rack or cabinet mounting options.

Mounting an EX3200 Switch on a Desk or Other Level Surface

You can mount an EX3200 switch on a desk or other level surface by using the 4 rubber feet that are shipped with the switch. The rubber feet stabilize the chassis.

Before mounting an EX3200 switch on a desk or other level surface:

- Verify that the site meets the requirements described in [“Site Preparation Checklist for EX3200 Switches” on page 53](#).
- Place the desk in its permanent location, allowing adequate clearance for airflow and maintenance, and secure it to the building structure.
- Read [“General Safety Guidelines and Warnings” on page 229](#), with particular attention to [“Chassis and Component Lifting Guidelines” on page 236](#).
- Remove the switch from the shipping carton (see [“Unpacking an EX3200 Switch” on page 92](#)).

Ensure that you have the following parts and tools available:

- 4 rubber feet to stabilize the chassis on the a desk or other level surface (provided in the accessory box shipped with the switch)

To mount the switch on a desk or other level surface:

1. Turn the chassis upside down on the desk or the level surface where you intend to mount the switch.
2. Attach the rubber feet to the bottom of the chassis, as shown in [Figure 24 on page 97](#).
3. Turn the chassis right side up on the desk or the level surface.

Figure 24: Attaching Rubber Feet to an EX3200 Switch Chassis

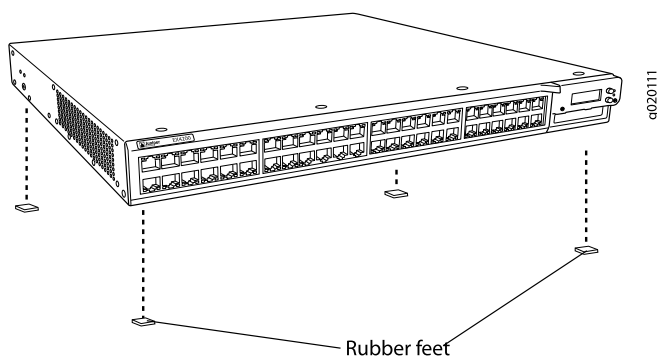

SEE ALSO

[Connecting AC Power to an EX3200 Switch | 114](#)

[Connecting DC Power to an EX3200 Switch | 117](#)

[Connecting and Configuring an EX Series Switch \(CLI Procedure\) | 132](#)

[Connecting and Configuring an EX Series Switch \(J-Web Procedure\) | 135](#)

Mounting an EX3200 Switch on Two Posts in a Rack or Cabinet

You can mount an EX3200 switch on two posts of a 19-in. rack (either a two-post or a four-post rack) or a 19-in. cabinet by using the mounting brackets provided with the switch. (The remainder of this topic uses “rack” to mean “rack or cabinet.”)

You can mount the switch on four posts of a four-post rack by using the mounting brackets provided with the separately orderable four-post rack-mount kit. See [“Mounting an EX3200 Switch on Four Posts in a Rack or Cabinet” on page 100.](#)

NOTE: If you need to mount the switch in a recessed position on either a two-post rack or a four-post rack, you can use the 2-in.-recess front brackets provided in the separately orderable four-post rack-mount kit.

Before mounting an EX3200 switch on two posts in a rack:

- Verify that the site meets the requirements described in [“Site Preparation Checklist for EX3200 Switches” on page 53.](#)
- Place the rack in its permanent location, allowing adequate clearance for airflow and maintenance, and secure it to the building structure.
- Read [“General Safety Guidelines and Warnings” on page 229,](#) with particular attention to [“Chassis and Component Lifting Guidelines” on page 236.](#)
- Remove the switch from the shipping carton (see [“Unpacking an EX3200 Switch” on page 92.](#))

Ensure that you have the following parts and tools available:

- Phillips (+) screwdriver, number 2
- 2 mounting brackets and 8 mounting screws (provided in the accessory box shipped with the switch)
- Screws to secure the chassis to the rack (not provided)
- 2-in.-recess front brackets if you will mount the switch in a recessed position (brackets are from the separately orderable four-post rack-mount kit).

NOTE: One person must be available to lift the switch while another secures the switch to the rack.



CAUTION: If you are mounting multiple switches on a rack, mount a switch in the bottom of the rack first and proceed to mount the rest of the switches from bottom to top.

To mount the switch on two posts in a rack:

1. Place the switch on a flat, stable surface.
2. Align the mounting brackets along the front, rear, or center of the side panels of the switch chassis depending on how you want to mount the switch. For example, if you want to front-mount the switch, align the brackets along the front of the side panel. See [Figure 25 on page 99](#).

Figure 25: Attaching the Mounting Bracket to the Side Panel of the Switch

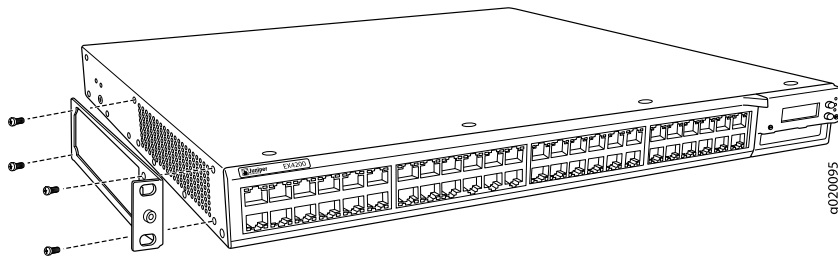

NOTE: If you need to mount the switch in a recessed position, use the 2-in.-recess front mount brackets from the separately orderable four-post rack-mount kit.

3. Align the bottom holes in the mounting brackets with holes on the side panels of the switch chassis.
4. Insert mounting screws into the aligned holes. Tighten the screws.
5. Ensure that the other holes in the mounting brackets are aligned with the holes in the side panels. Insert a screw in each hole and tighten the screws.
6. Have one person grasp both sides of the switch, lift the switch, and position it in the rack, aligning the mounting bracket holes with the threaded holes in the rack or cabinet rail. Align the bottom hole in both the mounting brackets with a hole in each rack rail, making sure the chassis is level. See [Figure 26 on page 100](#).

Figure 26: Mounting the Switch on Two Posts in a Rack

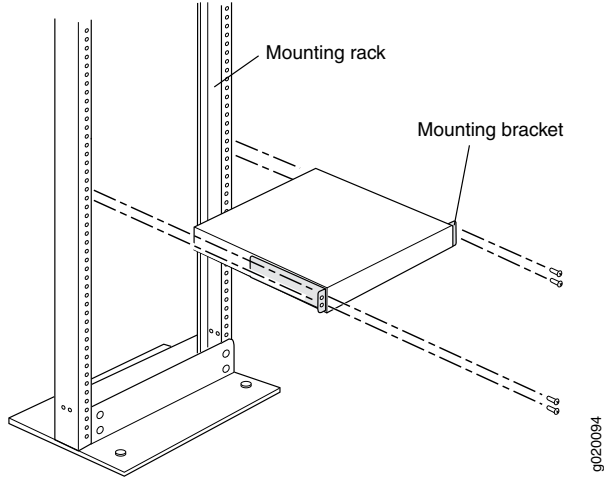

7. Have a second person secure the switch to the rack by using the appropriate screws. Tighten the screws.
8. Ensure that the switch chassis is level by verifying that all screws on one side of the rack are aligned with the screws on the other side.

SEE ALSO

[Rack-Mounting and Cabinet-Mounting Warnings](#) | 241

Mounting an EX3200 Switch on Four Posts in a Rack or Cabinet

You can mount an EX3200 switch on four posts of a 19-in. rack or cabinet by using the separately orderable four-post rack-mount kit. (The remainder of this topic uses “rack” to mean “rack or cabinet.”)

You can mount the switch on two posts in either a two-post rack or a four-post rack by using the mounting brackets provided with the switch. See [“Mounting an EX3200 Switch on Two Posts in a Rack or Cabinet” on page 98.](#)

NOTE: If you need to mount the switch in a recessed position on either a two-post rack or a four-post rack, you can use the 2-in.-recess front-mounting brackets provided in the separately orderable four-post rack-mount kit.

Before mounting the switch on four posts in a rack:

- Verify that the site meets the requirements described in [“Site Preparation Checklist for EX3200 Switches” on page 53](#).
- Place the rack in its permanent location, allowing adequate clearance for airflow and maintenance, and secure it to the building structure.
- Read [“General Safety Guidelines and Warnings” on page 229](#), with particular attention to [“Chassis and Component Lifting Guidelines” on page 236](#).
- Remove the switch from the shipping carton (see [“Unpacking an EX3200 Switch” on page 92](#)).

Ensure that you have the following parts and tools available:

- Phillips (+) screwdriver, number 2
- 6 flat-head 4-40 mounting screws (provided with the four-post rack-mount kit)
- 12 flat-head 4x6-mm Phillips mounting screws (provided with the four-post rack-mount kit)
- One pair each of flush or 2-in.-recess front-mounting brackets
- One pair of side mounting-rails
- One pair of rear mounting-blades
- Screws to secure the chassis and the rear mounting-blades to the rack (not provided)

NOTE: One person must be available to lift the switch while another secures it to the rack.



CAUTION: If you are mounting multiple units on a rack, mount the heaviest unit at the bottom of the rack and mount the other units from the bottom of the rack to the top in decreasing order of the weight of the units.

To mount the switch on four posts in a rack:

1. Attach the front-mounting brackets (either the flush or the 2-in.-recess brackets) to the side mounting-rails using six 4-40 flat-head Phillips mounting screws. See [Figure 27 on page 102](#).

Figure 27: Attaching the Front-Mounting Bracket to the Side Mounting-Rail

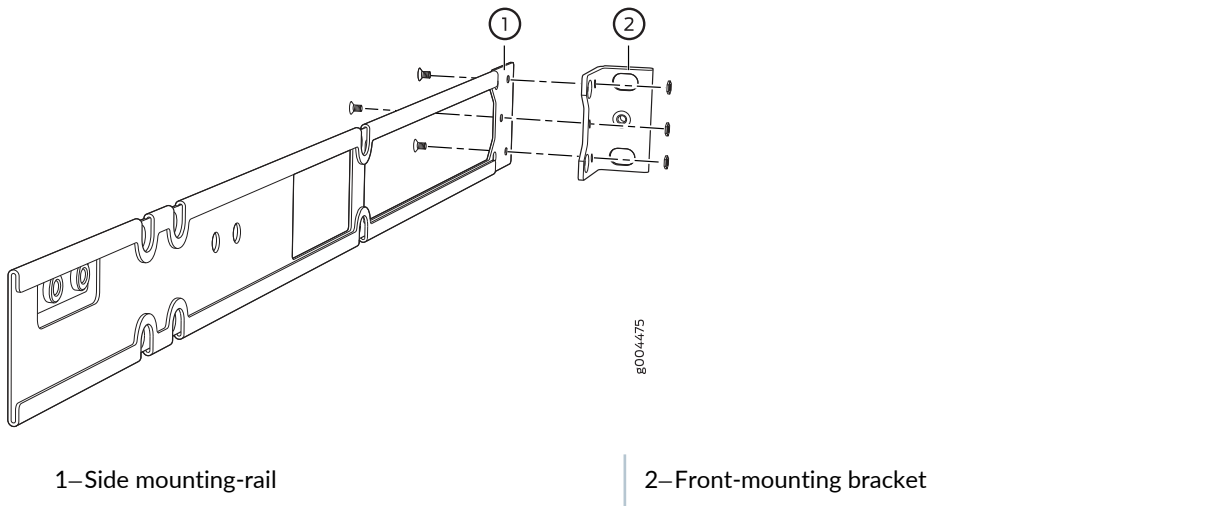

2. Place the switch on a flat, stable surface.
3. Align the side mounting-rails along the side panels of the switch chassis. Align the two holes in the rear of the side mounting-rails with the two holes on the rear of the side panel.
4. Insert 4x6-mm Phillips flat-head mounting screws into the two aligned holes and tighten the screws. Ensure that the remaining four holes in the side mounting-rails are aligned with the four holes in the side panel. See [Figure 28 on page 102](#).

Figure 28: Attaching the Side Mounting-Rail to the Switch Chassis

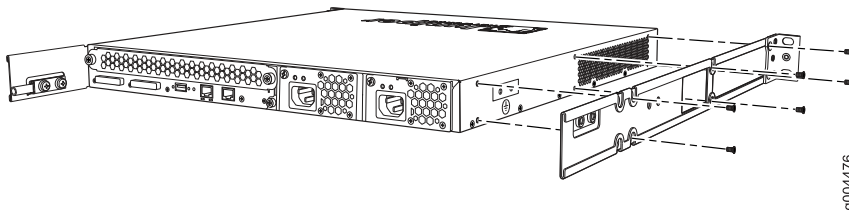

5. Insert the 4x6-mm Phillips flat-head mounting screws into the remaining four holes in the side mounting-rails and tighten the screws.

6. Have one person grasp both sides of the switch, lift the switch, and position it in the rack, aligning the side mounting-rail holes with the threaded holes in the front post of the rack. Align the bottom hole in both the front-mounting brackets with a hole in each rack rail, making sure the chassis is level. See [Figure 29 on page 103](#).

Figure 29: Mounting the Switch to the Front Posts in a Rack

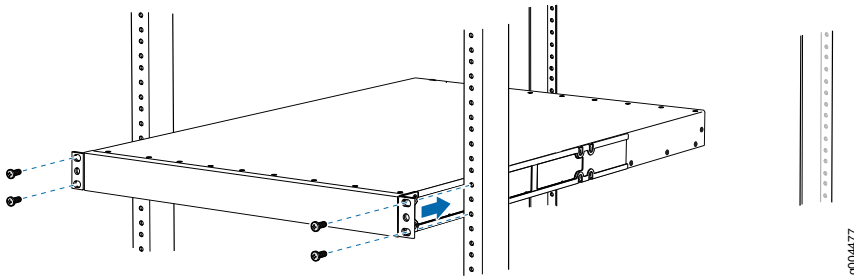

7. Have a second person secure the front of the switch to the rack by using the appropriate screws for your rack.
8. Slide the rear mounting-blades into the side mounting-rails. See [Figure 30 on page 103](#).

Figure 30: Sliding the Rear Mounting-Blades into the Side-Mounting Rail

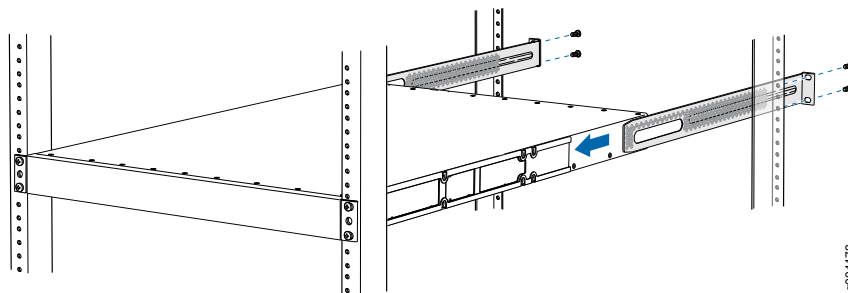

9. Attach the rear mounting-blades to the rear post by using the appropriate screws for your rack. Tighten the screws.
10. Ensure that the switch chassis is level by verifying that all the screws on the front of the rack are aligned with the screws at the back of the rack.

Mounting an EX3200 Switch in a Recessed Position in a Rack or Cabinet

You can mount an EX3200 switch in a rack or cabinet such that the switch is recessed inside the rack from the rack front by 2 inches. You can use the 2-in.-recess front brackets provided in the separately orderable four-post rack-mount kit to mount the switch in a recessed position.

Reasons that you might want to mount the switch in a recessed position include:

- You are mounting the switch in a cabinet and the cabinet doors will not close completely unless the switch is recessed.
- The switch you are mounting has an uplink module with transceivers installed in it—the transceivers in the uplink module ports protrude from the front of the switch.

To mount the switch in a recessed position on four posts, follow the instructions in [“Mounting an EX3200 Switch on Four Posts in a Rack or Cabinet” on page 100](#). To mount the switch in a recessed position on two posts, follow the instructions in [“Mounting an EX3200 Switch on Two Posts in a Rack or Cabinet” on page 98](#).

Mounting an EX3200 Switch on a Wall

You can mount an EX3200 switch on a wall by using the separately orderable wall-mount kit.

Before mounting an EX3200 switch on a wall:

- Verify that the site meets the requirements described in [“Site Preparation Checklist for EX3200 Switches” on page 53](#).
- Read [“General Safety Guidelines and Warnings” on page 229](#), with particular attention to [“Chassis and Component Lifting Guidelines” on page 236](#).
- Remove the switch from the shipping carton (see [“Unpacking an EX3200 Switch” on page 92](#)).

Ensure that you have the following parts and tools available:

- Phillips (+) screwdriver, number 2
- 2 wall-mount brackets (provided with the wall-mount kit)
- 12 wall-mount bracket screws (provided with the wall-mount kit)
- 4 mounting screws (8-32 x 1.25 in. or M4 x 30 mm) (not included)
- Hollow wall anchors capable of supporting the combined weight of two fully loaded switches, up to 44 lb (20 kg) (not included)—if you are mounting the switch in sheetrock (wall board with a gypsum plaster core) or in wall board not backed by wall studs



WARNING: When mounted in a vertical position, an EX3200 switch must be oriented with the front panel of the chassis pointing down in order to ensure proper airflow and meet safety requirements in the event of a fire.

NOTE: For easier lifting, install any additional power supplies only after you mount the switch on the wall.

To mount the switch on a wall:

1. Attach the wall-mount brackets to the sides of the chassis using four of the wall-mount bracket screws on each side, as shown in [Figure 31 on page 105](#).

Figure 31: Attaching Wall-Mount Brackets to the Switch Chassis

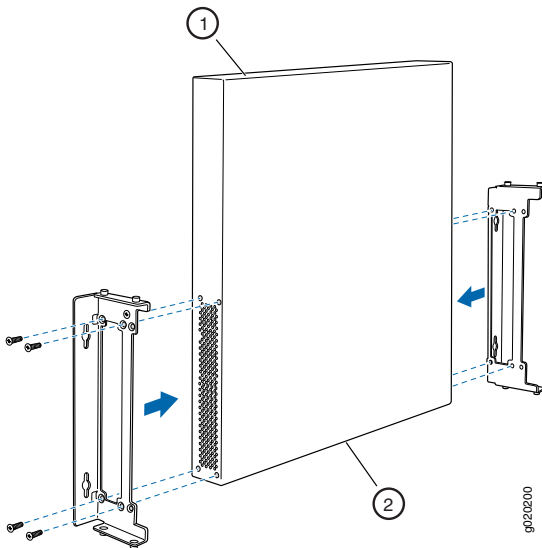

2. If you are mounting two switches together, line the second switch on top of the first and attach it to the mounting brackets using two wall-mount bracket screws on each side (see [Figure 32 on page 106](#)).
3. Insert the mounting screws in the wall. Insert the top pair of mounting screws 474.35 mm apart, and insert the second pair of mounting screws 151.81 mm directly below the first set.

If the mounting screws are inserted in wall board with no stud behind it, you must use dry wall anchors rated to support 75 lb (34 kg). Insert the screws into wall studs wherever possible to provide added support for the chassis.

Screw the screws only part way in, leaving about 1/4 in. (6 mm) distance between the head of the screw and the wall.

4. Grasp each side of the switch or switches, lift the switch or switches, and hang the brackets from the mounting screws as shown in [Figure 32 on page 106](#).

Figure 32: Mounting the Switch on a Wall

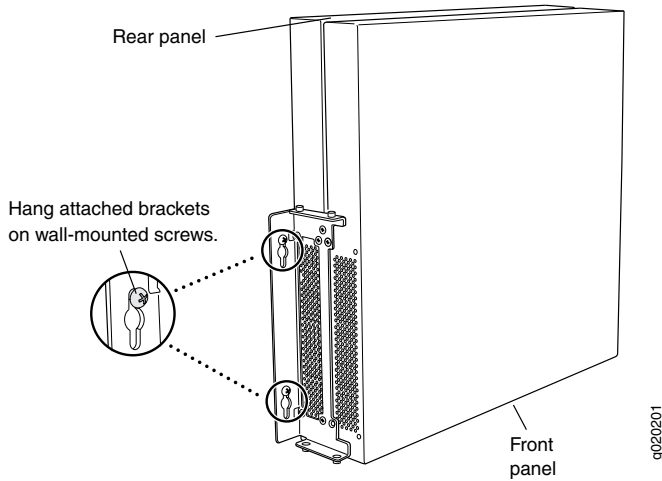

5. Tighten the mounting screws.

SEE ALSO

| [Wall-Mounting Warning for EX3200 Switches](#)

Connecting the EX3200 to Power

IN THIS SECTION

- [Connect Earth Ground to an EX Series Switch | 107](#)
- [Connecting AC Power to an EX3200 Switch | 114](#)
- [Connecting DC Power to an EX3200 Switch | 117](#)

Connect Earth Ground to an EX Series Switch

IN THIS SECTION

- [Parts and Tools Required for Connecting an EX Series Switch to Earth Ground | 107](#)
- [Special Instructions to Follow Before Connecting Earth Ground to an EX Series Switch | 112](#)
- [Connecting Earth Ground to an EX Series Switch | 113](#)

To ensure proper operation and to meet safety and electromagnetic interference (EMI) requirements, you must connect an EX Series switch to earth ground before you connect power to the switch. You must use the protective earthing terminal on the switch chassis to connect the switch to earth ground (see [Figure 34 on page 114](#)).

You must install the EX Series switch in a restricted-access location and ensure that the chassis is always properly grounded. EX Series switches have a two-hole protective grounding terminal provided on the chassis. See [Table 33 on page 108](#) for the location of the earthing terminals on various EX Series switches. We recommend that you use the protective grounding terminal as the preferred method for grounding the chassis regardless of the power supply configuration. However, if additional grounding methods are available, you can also use those methods. For example, you can use the grounding wire in the power cord of an AC power supply or use the grounding terminal or lug on a DC power supply. This system was tested to meet or exceed all applicable EMC regulatory requirements with the two-hole protective grounding terminal connected correctly.

Ensure that a licensed electrician has attached an appropriate grounding lug to the grounding cable you supply. Using a grounding cable with an incorrectly attached lug can damage the switch.

Parts and Tools Required for Connecting an EX Series Switch to Earth Ground

Before you begin connecting an EX Series switch to earth ground, ensure you have the parts and tools required for your switch.

[Table 33 on page 108](#) lists the earthing terminal location, grounding cable and lug specifications, and parts needed for connecting an EX Series switch to earth ground.

Table 33: Parts Required for Connecting an EX Series Switch to Earth Ground

Switch	Earthing Terminal Location	Grounding Cable Requirements	Grounding Lug Specifications	Screws and Washers	Additional Information
EX2200	Rear panel of the chassis	14 AWG (2 mm ²), minimum 90° C wire, or as permitted by the local code	Panduit LCC10-14BWL or equivalent— not provided	<ul style="list-style-type: none"> • Two 10-32 x .25 in. screws with #10 split-lock washer— not provided • Two #10 flat washers—not provided 	
EX2300-C	Rear panel of the chassis	14 AWG (2 mm ²), minimum 90° C wire, or as permitted by the local code	Panduit LCC10-14AW-L or equivalent— not provided	<ul style="list-style-type: none"> • Two 10-32 x .25 in. screws with #10 split-lock washer— not provided • Two #10 flat washers—not provided 	

Table 33: Parts Required for Connecting an EX Series Switch to Earth Ground (continued)

Switch	Earthing Terminal Location	Grounding Cable Requirements	Grounding Lug Specifications	Screws and Washers	Additional Information
EX2300	Rear panel of the chassis	<ul style="list-style-type: none"> EX2300 switches except EX2300-24MP and EX2300-48MP models—14 AWG (2 mm²), minimum 90°C wire, or as permitted by the local code EX2300-24MP and EX2300-48MP models—14-10 AWG STR (2.5-6 mm²), 12-10 AWG SOL (4-6 mm²) minimum 90°C wire, or as permitted by the local code—not provided 	<ul style="list-style-type: none"> EX2300 switches except EX2300-24MP and EX2300-48MP models—Panduit LCC10-14AW-L or equivalent—not provided EX2300-24MP and EX2300-48MP models—Panduit LCA10-10L or equivalent—not provided 	<ul style="list-style-type: none"> EX2300 switches except EX2300-24MP and EX2300-48MP models <ul style="list-style-type: none"> Two 10-32 x .25 in. screws with #10 split-lock washer—not provided Two #10 flat washers—not provided EX2300-24MP and EX2300-48MP models <ul style="list-style-type: none"> One Pan Phillips M 4 x 6 mm Nickel plated screw—provided 	
EX3200, EX3300, and EX3400	Rear panel of the chassis	14 AWG (2 mm ²), minimum 90° C wire, or as permitted by the local code	Panduit LCC10-14BWL or equivalent—not provided	<ul style="list-style-type: none"> Two 10-32 x .25 in. screws with #10 split-lock washer—not provided Two #10 flat washers—not provided 	For EX3200 Switches, see “Special Instructions to Follow Before Connecting Earth Ground to an EX Series Switch” on page 112.

Table 33: Parts Required for Connecting an EX Series Switch to Earth Ground (continued)

Switch	Earthing Terminal Location	Grounding Cable Requirements	Grounding Lug Specifications	Screws and Washers	Additional Information
EX4200, EX4500, and EX4550	Left side of the chassis	14 AWG (2 mm ²), minimum 90° C wire, or as permitted by the local code	Panduit LCC10-14BWL or equivalent— not provided	<ul style="list-style-type: none"> Two 10-32 x .25 in. screws with #10 split-lock washer— not provided Two #10 flat washers— not provided 	See “Special Instructions to Follow Before Connecting Earth Ground to an EX Series Switch” on page 112.
EX6210	Rear panel of the chassis (on lower left side)	The grounding cable must be the same gauge as the power feed cables and as permitted by the local code.	Panduit LCD2-14A-Q or equivalent— provided	<ul style="list-style-type: none"> Two ¼ -20 x 0.5 in. screws with #¼” split-washer— provided Two #¼” flat washers— provided 	
EX8208	Left side of the chassis	6 AWG (13.3 mm ²), minimum 90° C wire, or as permitted by the local code	Panduit LCD2-14A-Q or equivalent— provided	<ul style="list-style-type: none"> Two ¼ -20 x 0.5 in. screws with #¼” split-washer— provided Two #¼” flat washers— provided 	

Table 33: Parts Required for Connecting an EX Series Switch to Earth Ground (continued)

Switch	Earthing Terminal Location	Grounding Cable Requirements	Grounding Lug Specifications	Screws and Washers	Additional Information
EX8216	<p>Two earthing terminals:</p> <ul style="list-style-type: none"> • Left side of the chassis • Rear panel of the chassis <p>NOTE: You must use only one of the two protective earthing terminals.</p>	2 AWG (33.6 mm ²), minimum 90° C wire, or as permitted by the local code	Panduit LCD2-14A-Q or equivalent—provided	<ul style="list-style-type: none"> • Two ¼ -20 x 0.5 in. screws with #¼" split-washer—provided • Two #¼" flat washers—provided 	
EX9204, EX9208, and EX9214	Rear panel of the chassis	One 6 AWG (13.3 mm ²), minimum 90° C wire, or one that complies with the local code	Thomas& Betts LCN6-14 or equivalent—provided	<ul style="list-style-type: none"> • Two ¼ -20 x 0.5 in. screws with #¼" split-washer—provided • Two #¼" flat washers—provided 	See Grounding Cable and Lug Specifications for EX9200 Switches .
EX9251	Rear panel of the chassis	12 AWG (2.5 mm ²), minimum 90° C wire, or one that complies with the local code— not provided	Panduit LCD10-10A-L or equivalent— not provided	Two 10-32 screws— provided	See Grounding Cable and Lug Specifications for EX9200 Switches .

Table 33: Parts Required for Connecting an EX Series Switch to Earth Ground (*continued*)

Switch	Earthing Terminal Location	Grounding Cable Requirements	Grounding Lug Specifications	Screws and Washers	Additional Information
EX9253	Right side of the chassis	14-10 AWG (2-5.3 mm ²), minimum 90° C wire, or one that complies with the local code— not provided	Panduit LCD10-14B-L or equivalent— provided	Two M5 Pan Head screws— provided	

Tools required for connecting an EX Series switch to earth ground:

- An electrostatic discharge grounding strap (provided)
- A Phillips (+) number 2 screwdriver to tighten the screws.

An AC-powered EX Series switch gains additional grounding when you plug the power supply in the switch into a grounded AC power outlet by using an AC power cord appropriate for your geographical location.

Special Instructions to Follow Before Connecting Earth Ground to an EX Series Switch

[Table 34 on page 112](#) lists the special instructions that you might need to follow before connecting earth ground to a switch.

Table 34: Special Instructions to Follow Before Connecting Earth Ground to an EX Series Switch

Switch	Special Instructions
EX3200 and EX4200	Some early variants of EX3200 and EX4200 switches for which the Juniper Networks model number on the label next to the protective earthing terminal is from 750-021xxx through 750-030xxx require 10-24x.25 in. screws.

Table 34: Special Instructions to Follow Before Connecting Earth Ground to an EX Series Switch (continued)

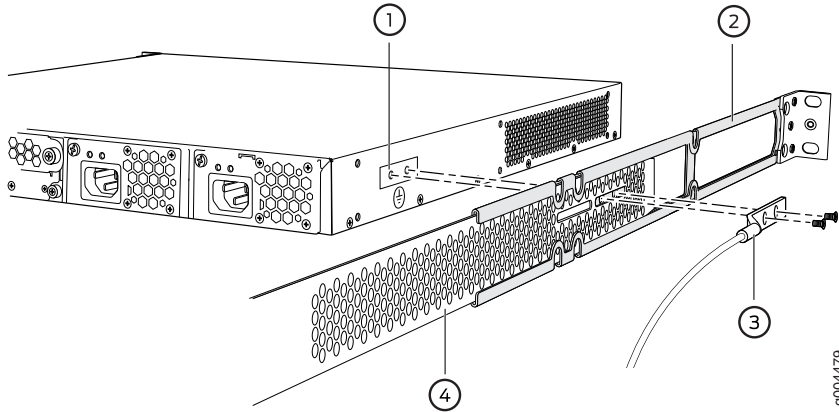
Switch	Special Instructions				
EX4200, EX4500, and EX4550	<p data-bbox="457 319 1455 401">If you plan to mount your switch on four posts of a rack or cabinet, mount your switch in the rack or cabinet before attaching the grounding lug to the switch.</p> <p data-bbox="457 422 1455 611">NOTE: The protective earthing terminal on switches mounted on four posts of a rack is accessible through the slot on the left rear bracket only if the rack is 27.5 in. (69.85 cm) through 30.5 in. (77.47 cm) deep for a switch mounted flush with the rack front and 29.5 in. (74.93 cm) through 32.5 in. (82.55 cm) deep for a switch mounted 2 in. (5.08 cm) recessed from the rack front. See Figure 33 on page 113.</p> <p data-bbox="457 653 1455 737">Figure 33: Connecting the Grounding Lug to a Switch Mounted on Four Posts of a Rack</p>  <p data-bbox="483 1220 1317 1318"> <table border="1"> <tr> <td>1-Protective earthing terminal</td> <td>3-Grounding lug</td> </tr> <tr> <td>2-Side mounting-rail</td> <td>4-Rear mounting-blade</td> </tr> </table> </p> <p data-bbox="457 1339 1455 1463">NOTE: The brackets must be attached to the chassis before the grounding lug is attached. (The brackets are shown pulled away from the chassis so that the protective earthing terminal is seen.)</p>	1-Protective earthing terminal	3-Grounding lug	2-Side mounting-rail	4-Rear mounting-blade
1-Protective earthing terminal	3-Grounding lug				
2-Side mounting-rail	4-Rear mounting-blade				

Connecting Earth Ground to an EX Series Switch

To connect earth ground to an EX Series switch:

1. Verify that a licensed electrician has attached the cable lug to the grounding cable.
2. Connect one end of the grounding cable to a proper earth ground, such as the rack in which the switch is mounted.

3. Attach an ESD grounding strap to your bare wrist, and connect the strap to the ESD grounding point on the switch.
4. Place the grounding lug attached to the grounding cable over the protective earthing terminal. See [Figure 34 on page 114](#).

Figure 34: Connecting a Grounding Cable to an EX Series Switch

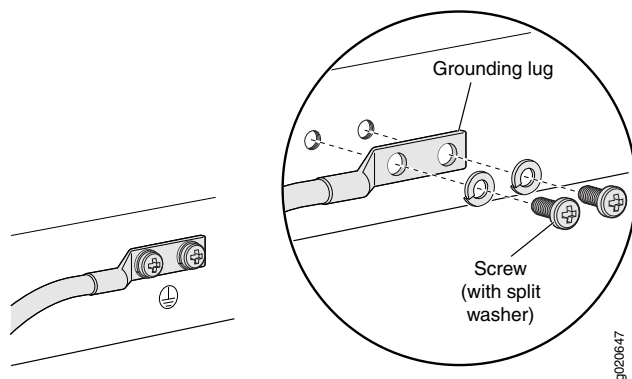

5. Secure the grounding lug to the protective earthing terminal with the washers and screws.
6. Dress the grounding cable and ensure that it does not touch or block access to other switch components and that it does not drape where people could trip over it.

SEE ALSO

[General Safety Guidelines and Warnings | 229](#)

[Grounded Equipment Warning | 247](#)

Connecting AC Power to an EX3200 Switch

The power supply in an EX3200 switch is a field-replaceable unit (FRU).

Before you begin connecting AC power to an EX3200 switch:

- Ensure that you have connected the device chassis to earth ground, if required by your site guidelines or installation. A ground connection to the protective earthing terminal is not required for an AC-powered switch. The AC power cords provide adequate grounding when you connect the power supply in the

switch to a grounded AC power outlet by using the AC power cord appropriate for your geographical location (see [“AC Power Cord Specifications for EX3200 Switches”](#) on page 50).



CAUTION: For installations that require a separate grounding conductor to the chassis, have a licensed electrician complete this connection before you connect the switch to power. For instructions on connecting earth ground, see [“Connect Earth Ground to an EX Series Switch”](#) on page 107.

- Install the power supply in the chassis. For instructions on installing a power supply in an EX3200 switch, see [“Installing a Power Supply in an EX3200 Switch”](#) on page 176.

NOTE: The power supply must be connected to a dedicated power source outlet.

Ensure that you have the following parts and tools available:

- A power cord appropriate for your geographical location

To connect AC power to the switch:

1. Ensure that the power supplies are fully inserted in the chassis and the screws on their faceplates are tightened.
2. Squeeze the two sides of the power cord retainer clip and insert the L-shaped ends of the wire clip into the holes in the bracket on each side of the AC power cord inlet on the AC power supply faceplate (see [Figure 35](#) on page 116).
3. Locate the power cord or cords shipped with the switch; the cords have plugs appropriate for your geographical location.



WARNING: Ensure that the power cord does not block access to switch components or drape where people can trip on it.

4. Insert the coupler end of the power cord into the AC power cord inlet on the AC power supply faceplate.
5. Push the cord into the slot in the adjustment nut of the power cord retainer. Turn the nut until it is tight against the base of the coupler and the slot in the nut is turned 90° from the top of the switch (see [Figure 36](#) on page 116).
6. If the AC power source outlet has a power switch, set it to the OFF (0) position.

7. Insert the power cord plug into an AC power source outlet.
8. If the AC power source outlet has a power switch, set it to the ON (I) position.
9. Verify that the **AC OK** LED on the power supply is lit and is on steadily.

NOTE: When you connect power to the switch, the Alarm (ALM) LED lights red. This behavior is normal. Plugging an active Ethernet cable into the management (MGMT) port on the switch completes the network link and turns off the ALM LED. (See [“Connect a Device to a Network for Out-of-Band Management”](#) on page 121.)

Connecting the switch to a dedicated management console instead of a network does not affect the ALM LED. The LED remains red until the switch is connected to a network.

Figure 35: Connecting the AC Power Cord Retainer Clip to an AC Power Supply in an EX3200 Switch

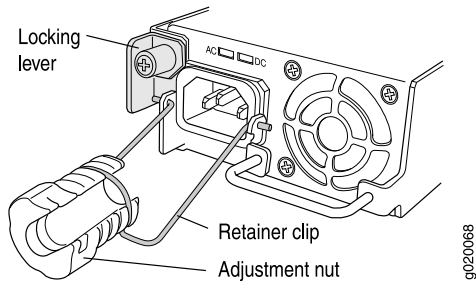
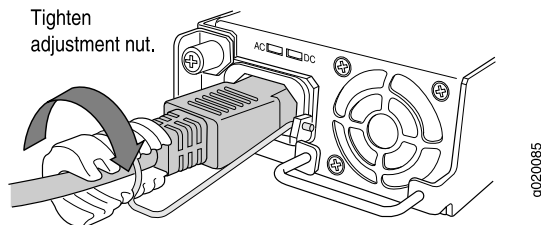

Figure 36: Connecting an AC Power Cord to an AC Power Supply in an EX3200 Switch



SEE ALSO

[Power Supply in EX3200 Switches](#) | 43

Connecting DC Power to an EX3200 Switch

The power supply in an EX3200 switch is a field-replaceable unit (FRU).

Figure 37: DC Power Supply in an EX3200 Switch

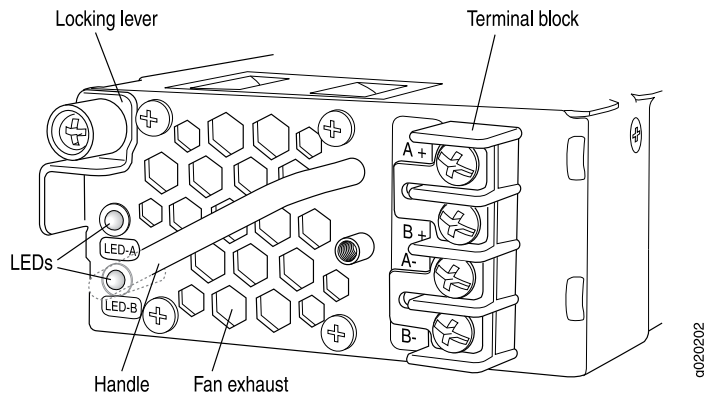

WARNING: DC-powered EX3200 switches are intended for installation only in a restricted access location.

Before you begin connecting DC power to an EX3200 switch:

- Ensure that you have connected the switch chassis to earth ground.



CAUTION: Before you connect power to the switch, a licensed electrician must attach a cable lug to the grounding and power cables that you supply. A cable with an incorrectly attached lug can damage the switch (for example, by causing a short circuit).

To meet safety and electromagnetic interference (EMI) requirements and to ensure proper operation, you must connect EX3200 switches to earth ground before you connect them to power. For installations that require a separate grounding conductor to the chassis, use the protective earthing terminal on the switch chassis to connect to the earth ground. For instructions on connecting earth ground, see [“Connect Earth Ground to an EX Series Switch” on page 107](#).

- Install the power supply in the chassis. For instructions on installing a power supply in an EX3200 switch, see [“Installing a Power Supply in an EX3200 Switch” on page 176](#).

Ensure that you have the following parts and tools available:

- DC power source cables (12–14 AWG) with ring lug (Molex 190700067 or equivalent) (not provided)
- Phillips (+) screwdriver, number 2

To connect DC power to the switch:

1. Ensure that the power supplies are fully inserted in the chassis and the screws on their faceplates are tightened.
2. Ensure that the input circuit breaker is open so that the voltage across the DC power source cable leads is 0 V and that the cable leads will not become active while you are connecting DC power.

NOTE: The DC power supply in the switch has four terminals labeled A+, B+, A-, and B- (see [Figure 37 on page 117](#)) for connecting DC power source cables labeled positive (+) and negative (-). The DC power supplies are shipped with jumpers from A+ input to B+ input tied together and jumpers from A- input to B- input tied together.

NOTE: The A+ and B+ terminals are referred to as +RTN and A- and B- terminals are referred to as -48 V in “[DC Power Wiring Sequence Warning](#)” on page 272 and “[DC Power Electrical Safety Guidelines](#)” on page 267.

3. Remove the screw securing the terminal block cover using the screwdriver and remove the terminal block cover (see [Figure 38 on page 118](#)). Save the screw.

Figure 38: Removing the Terminal Block Cover from a DC Power Supply

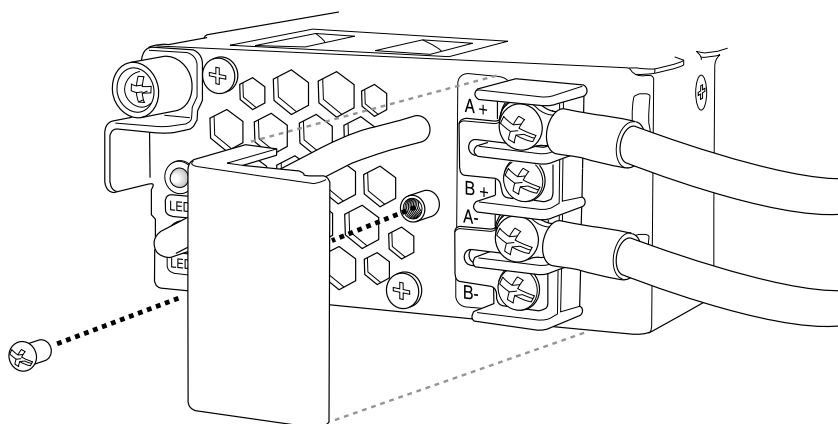

4. Remove the screws on the terminals using the screwdriver. Save the screws.



WARNING: Ensure that the power cables do not block access to switch components or drape where people can trip on them.

NOTE: To supply sufficient power, terminate the DC input wiring on a facility DC source that is capable of supplying a minimum of 8 A at -48 VDC.

5. Connect the power supplies to the power sources. Secure power source cables to the power supplies by screwing the ring lugs attached to the cables to the appropriate terminals by using the screw from the terminals (see [Figure 39 on page 120](#)).

- To connect a power supply to a power source:
 - a. Leave the jumpers on the power supply terminals in place.
 - b. Secure the ring lug of the positive (+) DC power source cable to the A+ or B+ terminal on the DC power supply.
 - c. Secure the ring lug of the negative (-) DC power source cable to the A- or B- terminal on the DC power supply.
 - d. Tighten the screws on the power supply terminals until snug using the screwdriver. Do not overtighten—apply between 8 lb-in. (0.9 Nm) and 9 lb-in. (1.02 Nm) of torque to the screws.

If you have a second installed power supply, connect it in the same way you did the first.

- To connect one power supply to two power sources:
 - a. Remove the jumpers on the power supply terminal block.
 - b. Secure the ring lug of the positive (+) DC power source cable from the first DC power source to the A+ terminal on the first DC power supply.
 - c. Secure the ring lug of the negative (-) DC power source cable from the first DC power source to the A- terminal on the first DC power supply.
 - d. Secure the ring lug of the positive (+) DC power source cable from the second DC power source to the A+ terminal on the second DC power supply.

- e. Secure the ring lug of the negative (-) DC power source cable from the second DC power source to the A- terminal on the second DC power supply.
- f. Tighten the screws on the power supply terminals on both the power supplies until snug using the screwdriver. Do not overtighten—apply between 8 lb-in. (0.9 Nm) and 9 lb-in. (1.02 Nm) of torque to the screws.

Figure 39: Securing Ring Lugs to the Terminals on the DC Power Supply

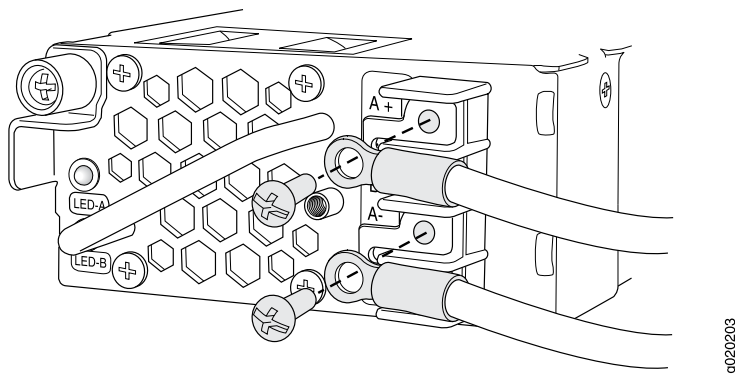

6. Replace the terminal block cover and secure it using the screw. Use the screwdriver to tighten the screw.
7. Close the input circuit breaker.
8. Verify that the LEDs on the power supply are lit green and are on steadily.

Connecting the EX3200 to External Devices

IN THIS SECTION

- [Connect a Device to a Network for Out-of-Band Management | 121](#)
- [Connect a Device to a Management Console Using an RJ-45 Connector | 121](#)

Connect a Device to a Network for Out-of-Band Management

You can monitor and manage these devices by using a dedicated management channel. Each device has a management port to which you can connect an Ethernet cable with an RJ-45 connector. Use the management port to connect the device to the management device.

Ensure that you have an Ethernet cable that has an RJ-45 connector at either end. [Figure 40 on page 121](#) shows the RJ-45 connector of the Ethernet cable supplied with the device.

Figure 40: RJ-45 Connector on an Ethernet Cable

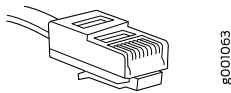

To connect a device to a network for out-of-band management (see [Figure 41 on page 121](#)):

1. Connect one end of the Ethernet cable to the management port on the device.
2. Connect the other end of the Ethernet cable to the management device.

Figure 41: Connect a Device to a Network for Out-of-Band Management

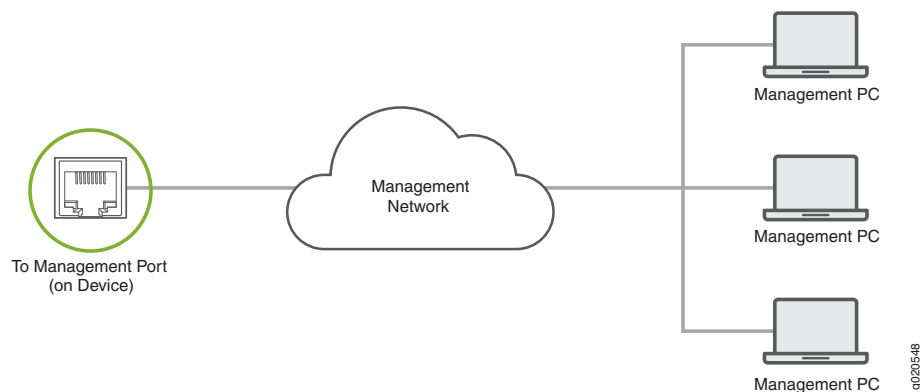

Connect a Device to a Management Console Using an RJ-45 Connector

You can configure and manage devices using a dedicated management channel. Each device has a console port which you can connect to using an Ethernet cable with an RJ-45 connector. Use the console port to connect the device to the console server or management console. The console port accepts a cable that has an RJ-45 connector.

Ensure that you have an Ethernet cable that has an RJ-45 connector at either end. One such cable and an RJ-45 to DB-9 serial port adapter are supplied with the device.

Figure 42 on page 122 shows the RJ-45 connector of the Ethernet cable.

Figure 42: RJ-45 Connector on an Ethernet Cable

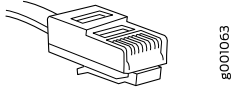

NOTE: If your laptop or desktop PC does not have a DB-9 plug connector pin and you want to connect your laptop or desktop PC directly to the device, use a combination of the RJ-45 to DB-9 socket adapter supplied with the device and a USB to DB-9 plug adapter. You must provide the USB to DB-9 plug adapter.

To connect the device to a management console (see Figure 43 on page 122 and Figure 44 on page 122):

1. Connect one end of the Ethernet cable to the console port (labeled **CON**, **CONSOLE**, or **CON1**) on the device.
2. Connect the other end of the Ethernet cable to the console server (see Figure 43 on page 122) or management console (see Figure 44 on page 122).

Figure 43: Connect a Device to a Management Console Through a Console Server

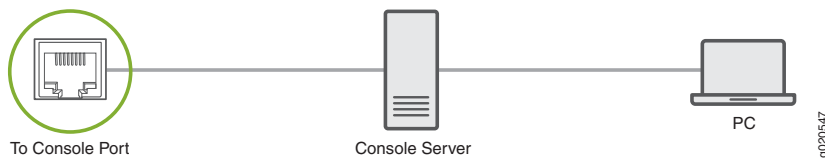
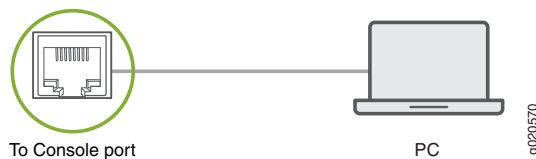

Figure 44: Connect a Device Directly to a Management Console



Connecting the EX3200 to the Network

IN THIS SECTION

- [Install a Transceiver | 123](#)
- [Connect a Fiber-Optic Cable | 126](#)

Install a Transceiver

The transceivers for Juniper Networks devices are hot-removable and hot-insertable field-replaceable units (FRUs): You can remove and replace them without powering off the device or disrupting the device functions.

NOTE: After you insert a transceiver or after you change the media-type configuration, wait for 6 seconds for the interface to display operational commands.

NOTE: We recommend that you use only optical transceivers and optical connectors purchased from Juniper Networks with your Juniper Networks device.



CAUTION: If you face a problem running a Juniper Networks device that uses a third-party optic or cable, the Juniper Networks Technical Assistance Center (JTAC) can help you diagnose the source of the problem. Your JTAC engineer might recommend that you check the third-party optic or cable and potentially replace it with an equivalent Juniper Networks optic or cable that is qualified for the device.

Before you install a transceiver in a device, ensure that you have taken the necessary precautions for safe handling of lasers (see [“Laser and LED Safety Guidelines and Warnings” on page 249](#)).

Ensure that you have a rubber safety cap available to cover the transceiver.

[Figure 45 on page 125](#) shows how to install a QSFP+ transceiver. The procedure is the same for all types of transceivers except the QSFP28 and CFP transceivers.

To install a transceiver:



CAUTION: To prevent electrostatic discharge (ESD) damage to the transceiver, do not touch the connector pins at the end of the transceiver.

1. Wrap and fasten one end of the ESD wrist strap around your bare wrist, and connect the other end of the strap to the ESD point on the switch.
2. Remove the transceiver from its bag.
3. Check to see whether the transceiver is covered with a rubber safety cap. If it is not, cover the transceiver with a rubber safety cap.



WARNING: Do not leave a fiber-optic transceiver uncovered except when inserting or removing a cable. The rubber safety cap keeps the port clean and prevents accidental exposure to laser light.

4. If the port in which you want to install the transceiver is covered with a dust cover, remove the dust cover and save it in case you need to cover the port later. If you are hot-swapping a transceiver, wait for at least 10 seconds after removing the transceiver from the port before installing a new transceiver.
5. Using both hands, carefully place the transceiver in the empty port. The connectors must face the chassis.



CAUTION: Before you slide the transceiver into the port, ensure that the transceiver is aligned correctly. Misalignment might cause the pins to bend, making the transceiver unusable.

6. Slide the transceiver in gently until it is fully seated. If you are installing a CFP transceiver, tighten the captive screws on the transceiver by using your fingers.
7. Remove the rubber safety cap from the transceiver and the end of the cable, and insert the cable into the transceiver.



WARNING: Do not look directly into a fiber-optic transceiver or into the ends of fiber-optic cables. Fiber-optic transceivers and fiber-optic cable connected to a transceiver emit laser light that can damage your eyes.



CAUTION: Do not leave a fiber-optic transceiver uncovered except when inserting or removing cable. The safety cap keeps the port clean and prevents accidental exposure to laser light.

8. If there is a cable management system, arrange the cable in the cable management system to prevent the cable from dislodging or developing stress points. Secure the cable so that it does not support its own weight as it hangs to the floor. Place excess cable out of the way in a neatly coiled loop in the cable management system. Placing fasteners on the loop helps to maintain its shape.



CAUTION: Do not let fiber-optic cable hang free from the connector. Do not allow fastened loops of cable to dangle, which stresses the cable at the fastening point.



CAUTION: Avoid bending fiber-optic cable beyond its minimum bend radius. An arc smaller than a few inches in diameter can damage the cable and cause problems that are difficult to diagnose.

Figure 45: Install a Transceiver

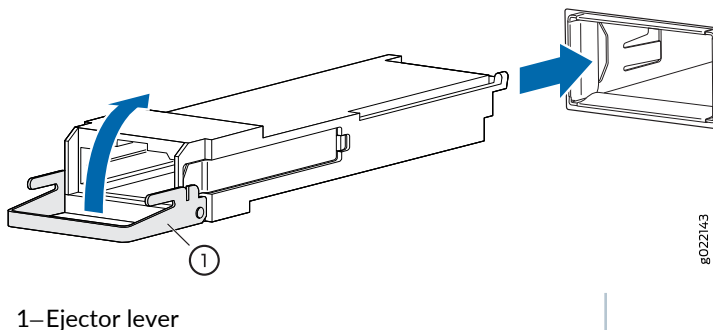

Connect a Fiber-Optic Cable

Before you connect a fiber-optic cable to an optical transceiver installed in a device, ensure that you have taken the necessary precautions for safe handling of lasers (see “[Laser and LED Safety Guidelines and Warnings](#)” on page 249).

To connect a fiber-optic cable to an optical transceiver installed in a device:



WARNING: Do not look directly into a fiber-optic transceiver or into the ends of fiber-optic cables. Fiber-optic transceivers and fiber-optic cables connected to transceivers emit laser light that can damage your eyes.

1. If the fiber-optic cable connector is covered with a rubber safety cap, remove the cap. Save the cap.
2. Remove the rubber safety cap from the optical transceiver. Save the cap.
3. Insert the cable connector into the optical transceiver (see [Figure 46 on page 126](#)).

Figure 46: Connect a Fiber-Optic Cable to an Optical Transceiver Installed in a Device

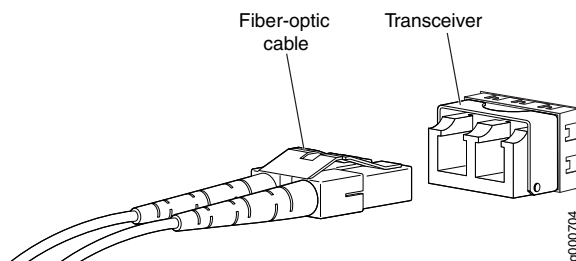

4. Secure the cables so that they do not support their own weight. Place excess cable out of the way in a neatly coiled loop. Placing fasteners on a loop helps cables maintain their shape.



CAUTION: Do not bend fiber-optic cables beyond their minimum bend radius. An arc smaller than a few inches in diameter can damage the cables and cause problems that are difficult to diagnose.

Do not let fiber-optic cables hang free from the connector. Do not allow fastened loops of cables to dangle, which stresses the cables at the fastening point.

Configuring Junos OS on the EX3200

IN THIS SECTION

- [EX3200 Default Configuration | 127](#)
- [Connecting and Configuring an EX Series Switch \(CLI Procedure\) | 132](#)
- [Connecting and Configuring an EX Series Switch \(J-Web Procedure\) | 135](#)
- [Configuring the LCD Panel on EX Series Switches \(CLI Procedure\) | 139](#)

EX3200 Default Configuration

Each EX Series switch is programmed with a factory default configuration that contains the values set for each configuration parameter when a switch is shipped. The default configuration file sets values for system parameters such as **syslog** and **commit**; configures Power over Ethernet (PoE), storm control, and Ethernet switching on all interfaces; and enables the LLDP and RSTP protocols.

When you commit changes to the configuration, a new configuration file is created that becomes the active configuration. You can always revert to the factory default configuration. See *Reverting to the Default Factory Configuration for the EX Series Switch*.

The following factory default configuration file is for an EX3200 switch with 24 ports (for models that have more ports, this default configuration file has more interfaces):

NOTE: In this example, **ge-0/0/0** through **ge-0/0/23** are the network interface ports. Optional uplink modules provide either two 10-gigabit small form-factor pluggable (XFP) transceivers (**xe-0/1/0** and **xe-0/1/1**) or four 1-gigabit SFP transceivers (**ge-0/1/0** through **ge-0/1/3**). Although you can install only one uplink module, the interfaces for both are shown below.

```
system {
  syslog {
    user * {
      any emergency;
    }
  }
  file messages {
```

```
    any notice;
    authorization info;
  }
  file interactive-commands {
    interactive-commands any;
  }
}
commit {
  factory-settings {
    reset-chassis-lcd-menu;
    reset-virtual-chassis-configuration;
  }
}
}
interfaces {
  ge-0/0/0 {
    unit 0 {
      family ethernet-switching;
    }
  }
  ge-0/0/1 {
    unit 0 {
      family ethernet-switching;
    }
  }
  ge-0/0/2 {
    unit 0 {
      family ethernet-switching;
    }
  }
  ge-0/0/3 {
    unit 0 {
      family ethernet-switching;
    }
  }
  ge-0/0/4 {
    unit 0 {
      family ethernet-switching;
    }
  }
  ge-0/0/5 {
    unit 0 {
      family ethernet-switching;
    }
  }
}
```



```
}  
ge-0/0/6 {  
  unit 0 {  
    family ethernet-switching;  
  }  
}  
ge-0/0/7 {  
  unit 0 {  
    family ethernet-switching;  
  }  
}  
ge-0/0/8 {  
  unit 0 {  
    family ethernet-switching;  
  }  
}  
ge-0/0/9 {  
  unit 0 {  
    family ethernet-switching;  
  }  
}  
ge-0/0/10 {  
  unit 0 {  
    family ethernet-switching;  
  }  
}  
ge-0/0/11 {  
  unit 0 {  
    family ethernet-switching;  
  }  
}  
ge-0/0/12 {  
  unit 0 {  
    family ethernet-switching;  
  }  
}  
ge-0/0/13 {  
  unit 0 {  
    family ethernet-switching;  
  }  
}  
ge-0/0/14 {  
  unit 0 {  
    family ethernet-switching;  
  }  
}
```

```
    }  
  }  
  ge-0/0/15 {  
    unit 0 {  
      family ethernet-switching;  
    }  
  }  
  ge-0/0/16 {  
    unit 0 {  
      family ethernet-switching;  
    }  
  }  
  ge-0/0/17 {  
    unit 0 {  
      family ethernet-switching;  
    }  
  }  
  ge-0/0/18 {  
    unit 0 {  
      family ethernet-switching;  
    }  
  }  
  ge-0/0/19 {  
    unit 0 {  
      family ethernet-switching;  
    }  
  }  
  ge-0/0/20 {  
    unit 0 {  
      family ethernet-switching;  
    }  
  }  
  ge-0/0/21 {  
    unit 0 {  
      family ethernet-switching;  
    }  
  }  
  ge-0/0/22 {  
    unit 0 {  
      family ethernet-switching;  
    }  
  }  
  ge-0/0/23 {  
    unit 0 {
```

```
        family ethernet-switching;
    }
}
xe-0/1/0 {
    unit 0 {
        family ethernet-switching;
    }
}
xe-0/1/1 {
    unit 0 {
        family ethernet-switching;
    }
}
ge-0/1/0 {
    unit 0 {
        family ethernet-switching;
    }
}
ge-0/1/1 {
    unit 0 {
        family ethernet-switching;
    }
}
ge-0/1/2 {
    unit 0 {
        family ethernet-switching;
    }
}
ge-0/1/3 {
    unit 0 {
        family ethernet-switching;
    }
}
}
protocols {
    igmp-snooping {
        vlan all;
    }
    lldp {
        interface all;
    }
    lldp-med {
        interface all;
    }
}
```

```
    rstp;
}
ethernet-switching-options {
    storm-control {
        interface all;
    }
}
poe {
    interface all;
}
```

Connecting and Configuring an EX Series Switch (CLI Procedure)

There are two ways to connect and configure an EX Series switch: one method is through the console by using the CLI and the other is by using the J-Web interface.

NOTE: EX2200-24T-4G-DC switches do not support switch connection and configuration through the J-Web interface.

This topic describes the CLI procedure.

NOTE: To run the **ezsetup** script, the switch must have the factory-default configuration as the active configuration. If you have configured anything on the switch and want to run **ezsetup**, revert to the factory-default configuration. See *Reverting to the Default Factory Configuration for the EX Series Switch*.

Using the CLI, set the following parameter values in the console server or PC:

- Baud rate—9600
- Flow control—None
- Data—8
- Parity—None
- Stop bits—1
- DCD state—Disregard

To connect and configure the switch from the console by using the CLI:

1. Connect the console port to a laptop or PC by using the RJ-45 to DB-9 serial port adapter. An Ethernet cable that has an RJ-45 connector at either end and an RJ-45 to DB-9 serial port adapter are supplied with the switch. If your laptop doesn't have a serial port, use a serial to USB adapter.

For the location of the console port on different EX Series switches:

- See *EX2200 Switches Hardware Overview*.
- See *EX2300 Switches Hardware Overview*.
- See ["Rear Panel of an EX3200 Switch" on page 26](#).
- See *Rear Panel of an EX3300 Switch*.
- See *Rear Panel of an EX3400 Switch*.
- See *Rear Panel of an EX4200 Switch*.
- See *EX4300 Switches Hardware Overview*
- See *Front Panel of an EX4500 Switch*.
- See *EX4550 Switches Hardware Overview*
- See *Switch Fabric and Routing Engine (SRE) Module in an EX6200 Switch*.
- See *Switch Fabric and Routing Engine (SRE) Module in an EX8208 Switch*.
- See *Routing Engine (RE) Module in an EX8216 Switch*.

NOTE: In EX2200-C, EX2300, EX3400, EX4300, and EX4550 switches, you can also use the Mini-USB Type-B console port to connect to a laptop or PC. See *Connect an EX Series Switch to a Management Console Using the Mini-USB Type-B Console Port*.

2. At the Junos OS shell prompt **root%**, type **ezsetup**.
3. Enter the hostname. This is optional.
4. Enter the root password you want to use for the device. Reenter the root password when prompted.

5. Enable services such as SSH and Telnet.

NOTE: You will not be able to log in to the switch as the **root** user through Telnet. Root login is allowed only through SSH.

- The default option for SSH is **yes**. Select this to enable SSH.
- The default option for Telnet is **no**. Change this to **yes** to enable Telnet.

6. Use the Management Options page to select the management scenario:

NOTE: On EX2300 and EX3400 switches, you cannot create a new VLAN for management. On EX4500, EX6200, and EX8200 switches, only the out-of-band management option is available.

- *Configure in-band management.* In in-band management, you configure a network interface or an uplink module (expansion module) interface as the management interface and connect it to the management device.
In this scenario, you have the following two options:
 - Use the automatically created VLAN *default* for management—Select this option to configure all data interfaces as members of the default VLAN. Specify the management IP address and the default gateway.
 - Create a new VLAN for management—Select this option to create a management VLAN. Specify the VLAN name, VLAN ID, management IP address, and default gateway. Select the ports that must be part of this VLAN.
- *Configure out-of-band management*—Configure the management port. In out-of-band management, you use a dedicated management channel (**MGMT** port) to connect to the management device. Specify the IP address and gateway of the management interface. Use this IP address to connect to the switch.

7. Specify the SNMP read community, location, and contact to configure SNMP parameters. These parameters are optional.
8. Specify the system date and time. Select the time zone from the list. These options are optional.

9. The configured parameters are displayed. Enter **yes** to commit the configuration. The configuration is committed as the active configuration for the switch.
10. (For EX4500 switches only) Enter the operational mode command **request chassis pic-mode intraconnect** to set the PIC mode to intraconnect.

You can now log in with the CLI or the J-Web interface to continue configuring the switch. If you use the J-Web interface to continue configuring the switch, the Web session is redirected to the new management IP address. If the connection cannot be made, the J-Web interface displays instructions for starting a J-Web session.

SEE ALSO

[Connecting and Configuring an EX Series Switch \(J-Web Procedure\) | 135](#)

[Installing and Connecting an EX2200 Switch](#)

[Installing and Connecting an EX2300 Switch](#)

[Installing and Connecting an EX3200 Switch | 95](#)

[Installing and Connecting an EX3300 Switch](#)

[Installing and Connecting an EX3400 Switch](#)

[Installing and Connecting an EX4200 Switch](#)

[Installing and Connecting an EX4300 Switch](#)

[Installing and Connecting an EX4550 Switch](#)

[Installing and Connecting an EX4500 Switch](#)

[Installing and Connecting an EX6210 Switch](#)

[Installing and Connecting an EX8208 Switch](#)

[Installing and Connecting an EX8216 Switch](#)

Connecting and Configuring an EX Series Switch (J-Web Procedure)

There are two ways to connect and configure an EX Series switch: one method is through the console by using the CLI and the other is by using the J-Web interface.

Starting in Junos OS Release 19.2R1, J-Web supports EX4650 switches.

NOTE: You cannot connect to and perform initial configuration of EX2200-24T-4G-DC, EX4300-48MP, EX4300-48MP-S switches, and EX4600 switches using EZSetup procedure from the J-Web interface. For EX2200-24T-4G-DC switches, you must use EZSetup from the switch console. For EX4300-48MP, EX4300-48MP-S, and EX4600 switches, you must use the CLI procedure through the switch console.

This topic describes the J-Web procedure.

NOTE: Before you begin the configuration, enable a DHCP client on the management PC that you will connect to the switch so that the PC can obtain an IP address dynamically.

NOTE: Read the following steps before you begin the configuration. You must complete the initial configuration by using EZSetup within 10 minutes. The switch exits EZSetup after 10 minutes and reverts to the factory default configuration, and the PC loses connectivity to the switch.

- EX2200 and EX2200-C switch—The LEDs on the network ports on the front panel blink when the switch is in the initial setup mode.
- EX3200, EX3300, EX4200, EX4300 switches except EX4300-48MP and EX4300-48MP-S switches, EX4500, EX4550, EX6200, or EX8200 switch—The LCD panel displays a count-down timer when the switch is in initial setup mode.

NOTE: There is no LCD panel on EX4300-48MP and EX4300-48MP-S switches.

To connect and configure the switch by using the J-Web interface:

1. Transition the switch into initial setup mode:

- EX2200 and EX2200-C switch—Press the mode button located on the lower right corner of the front panel for 10 seconds.
- EX3200, EX3300, EX4200, EX4300 switches except EX4300-48MP and EX4300-48MP-S switches, EX4500, EX4550, EX6200, or EX8200 switch—Use the **Menu** and **Enter** buttons located to the right of the LCD panel (see [Figure 47 on page 137](#) or [Figure 48 on page 137](#)):

Figure 47: LCD Panel in an EX3200, EX4200, EX4500, EX4550, or EX8200 Switch

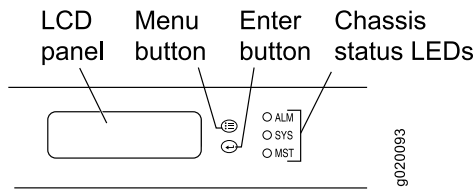
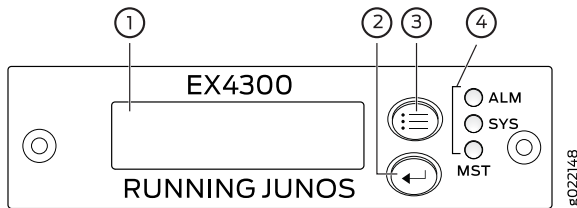

Figure 48: LCD Panel in an EX4300 Switches Except EX4300-48MP and EX4300-48MP-S Switches



1—LCD panel

3—LCD panel Menu button

2—LCD panel Enter button

4—Chassis status LEDs

1. Press the **Menu** button until you see **MAINTENANCE MENU**. Then press the **Enter** button.
2. Press **Menu** until you see **ENTER EZSetup**. Then press **Enter**.

If EZSetup does not appear as an option in the menu, select **Factory Default** to return the switch to the factory default configuration. EZSetup is displayed in the menu of standalone switches only when a switch is set to the factory default configuration.

3. Press **Enter** to confirm setup and continue with EZSetup.

2. Connect the Ethernet cable from the Ethernet port on the PC to the switch.

- EX2200, EX3200, or EX4200 switch—Connect the cable to port 0 (ge-0/0/0) on the front panel of the switch.
- EX3300 switch—Connect the cable to the port labeled **MGMT** on the rear panel of the switch.
- EX4300 switches except EX4300-48MP and EX4300-48MP-S switches—Connect the cable to the port labeled **MGMT** on the rear panel of the switch.

- EX4500 or EX4550 switch—Connect the cable to the port labeled **MGMT** on the front panel (LCD panel side) of the switch.
- EX4650 switches—Connect the cable to the port labeled **CON** on the rear panel of the switch.
- EX6200 switch—Connect the cable to one of the ports labeled **MGMT** on the Switch Fabric and Routing Engine (SRE) module in slot 4 or 5 in an EX6210 switch.
- EX8200 switch—Connect the cable to the port labeled **MGMT** on the Switch Fabric and Routing Engine (SRE) module in slot SRE0 in an EX8208 switch or on the Routing Engine (RE) module in slot RE0 in an EX8216 switch.

These ports are configured as the DHCP server with the default IP address, 192.168.1.1. The switch can assign an IP address to the management PC in the IP address range 192.168.1.2 through 192.168.1.253.

3. From the PC, open a Web browser, type **http://192.168.1.1** in the address field, and press **Enter**.
4. On the J-Web login page, type **root** as the username, leave the password field blank, and click **Login**.
5. On the Introduction page, click **Next**.
6. On the Basic Settings page, modify the hostname, the root password, and date and time settings:
 - Enter the hostname. This is optional.
 - Enter a password and reenter the password.
 - Specify the time zone.
 - Synchronize the date and time settings of the switch with the management PC or set them manually by selecting the appropriate option button. This is optional.

Click **Next**.

7. Use the Management Options page to select the management scenario:

NOTE: On EX2300 and EX3400 switches, you cannot create a new VLAN for management.

On EX4500, EX6210, and EX8200 switches, only the out-of-band management option is available.

- *Configure in-band management.* In in-band management, you configure a network interface or an uplink module (expansion module) interface as the management interface and connect it to the management device.

In this scenario, you have the following two options:

- Use the automatically created VLAN *default* for management—Select this option to configure all data interfaces as members of the default VLAN. Specify the management IP address and the default gateway.
 - Create a new VLAN for management—Select this option to create a management VLAN. Specify the VLAN name, VLAN ID, management IP address, and default gateway. Select the ports that must be part of this VLAN.
 - *Configure out-of-band management*—Configure the management port. In out-of-band management, you use a dedicated management channel (**MGMT** port) to connect to the management device. Specify the IP address and gateway of the management interface. Use this IP address to connect to the switch.
8. Click **Next**.
 9. On the Manage Access page, you can select options to enable Telnet, SSH, and SNMP services. For SNMP, you can configure the read community, location, and contact.
 10. Click **Next**. The Summary screen displays the configured settings.
 11. Click **Finish**. The configuration is committed as the active switch configuration.

NOTE: After the configuration is committed, the connectivity between the PC and the switch might be lost. To renew the connection, release and renew the IP address by executing the appropriate commands on the management PC or by removing and reinserting the Ethernet cable.

12. (For EX4500 switches only) In the CLI, enter the **request chassis pic-mode intraconnect** operational mode command to set the PIC mode to intraconnect.

You can now log in by using the CLI or the J-Web interface to continue configuring the switch.

If you use the J-Web interface to continue configuring the switch, the Web session is redirected to the new management IP address. If the connection cannot be made, the J-Web interface displays instructions for starting a J-Web session.

Configuring the LCD Panel on EX Series Switches (CLI Procedure)

This topic applies to hardware devices in the EX Series product family, which includes switches and the XRE200 External Routing Engine, that support the LCD panel interface.

The LCD panel on the front panel of EX Series switches displays a variety of information about the switch in the Status menu and provides the Maintenance menu to enable you to perform basic operations such as initial setup and reboot. You can disable these menus or individual menu options if you do not want switch users to use them. You can also set a custom message that will be displayed on the panel.

- [Disabling or Enabling Menus and Menu Options on the LCD Panel | 140](#)
- [Configuring a Custom Display Message | 141](#)

Disabling or Enabling Menus and Menu Options on the LCD Panel

By default, the Maintenance menu, the Status menu, and the options in those menus in the LCD panel are enabled. Users can configure and troubleshoot the switch by using the Maintenance menu and view certain details about the switch by using the Status menu.

If you do not want users to be able to use those menus or some of the menu options, you can disable the menus or individual menu options. You can reenable the menus or menu options.

Issue the **show chassis lcd menu** operational mode command to see the menus or menu options that are currently enabled.

NOTE: On some platforms, you must specify an FPC slot number in these commands. See the *lcd-menu* statement for details.

To disable a menu:

```
[edit]
```

```
user@switch# set chassis lcd-menu menu-item menu-name disable
```

To enable a menu:

```
[edit]
```

```
user@switch# delete chassis lcd-menu menu-item menu-name disable
```

To disable a menu option:

```
[edit]
```

```
user@switch# set chassis lcd-menu menu-item menu-option disable
```

To enable a menu option:

```
[edit]
```

```
user@switch# delete chassis lcd-menu menu-item menu-option disable
```

Configuring a Custom Display Message

You can configure the second line of the LCD to display a custom message temporarily for 5 minutes or permanently.

To display a custom message temporarily:

- On an EX3200 switch, a standalone EX3300 switch, a standalone EX4200 switch, a standalone EX4300 switch except EX4300-48MP and EX4300-48MP-S switches, a standalone EX4500 switch, a standalone EX4550 switch, an EX6200 switch, an EX8200 switch, or an XRE200 External Routing Engine:

```
user@switch> set chassis display message message
```

- On an EX3300, EX4200, EX4300, EX4500, or EX4550 switch in a Virtual Chassis configuration:

```
user@switch> set chassis display message message fpc-slot slot-number
```

To display a custom message permanently:

- On an EX3200 switch, a standalone EX3300 switch, a standalone EX4200 switch, a standalone EX4300 switch except EX4300-48MP and EX4300-48MP-S switches, a standalone EX4500 switch, a standalone EX4550 switch, an EX6200 switch, an EX8200 switch, or an XRE200 External Routing Engine:

```
user@switch> set chassis display message message permanent
```

- On an EX3300, EX4200, EX4300 except EX4300-48MP and EX4300-48MP-S, EX4500, or EX4550 switch in a Virtual Chassis configuration:

```
user@switch> set chassis display message message fpc-slot slot-number permanent
```

NOTE: The buttons on the LCD panel are disabled when the LCD is configured to display a custom message.

To disable the display of the custom message:

```
user@switch> clear chassis display message
```

You can view the custom message by issuing the `show chassis lcd` command.

Dashboard for EX Series Switches

IN THIS SECTION

- [Graphical Chassis Viewer | 143](#)
- [System Information Panel | 145](#)
- [Health Status Panel | 148](#)
- [Capacity Utilization Panel | 152](#)
- [Alarms Panel | 153](#)
- [File System Usage | 153](#)
- [Chassis Viewer | 153](#)

NOTE: This topic applies only to the J-Web Application package.

When you log in to the J-Web user interface, the dashboard for the Juniper Networks EX Series Ethernet Switches appears. Use the dashboard to view system information.

The Update Available window appears if there is a latest update of the J-Web Application package available on the Juniper Networks server. This window is enabled by the auto update feature of J-Web.

NOTE:

- The Update Available window will *not* appear when you log in, if you have not selected the **Check for updates automatically on every login** in the *Update Preference* section in the **Maintain > Update J-Web** side pane. By default, the *Check for update automatically on every login* is selected.
- If you choose *Update Later*, you can update to the latest J-Web Application package by clicking the orange icon next to *Update Available* on the top pane of the J-Web interface or through **Maintain > Update J-Web**.

The dashboard comprises a graphical chassis viewer and four panels.

Graphical Chassis Viewer

The Dashboard panel displays a graphical view of the chassis of a switch. In a Virtual Chassis, it displays a graphical view of each member switch.

In a Virtual Chassis, the default values are shown on the Dashboard panel when no chassis image is clicked. The panel displays the value for a switch if you click its image.

NOTE:

- If the member switch is not present, inactive, or not provisioned, you cannot expand the member switch image.

In J-Web Application package Release 14.1X53-A2, you can form a Virtual Chassis using EX4600 and EX4300 switches. When in a mixed Virtual Chassis consisting of EX4600 switches and EX4300 switches, the EX4600 switches can be the primary, backup, or in the linecard role, while the EX4300 switches must be in the linecard role.

- Starting in J-Web Application Package Release 19.2A1, J-Web supports EX4650 switches.

NOTE: For EX4650 switches, chassis viewer supports only the standalone view and does not support the Virtual Chassis configuration.

Table 35 on page 143 lists the details that are displayed on each member switch.

Table 35: Details of a Virtual Chassis Member Switch

Details	Example
Model number of the member switch	EX3300
Assigned ID that applies to the entire Virtual Chassis configuration	ID 2 NOTE: If the member switch is not provisioned, the serial number of the switch is displayed instead of its ID.
Role of the member switch	Master Possible roles are: Master, Backup, or Linecard
Status of the member switch	Prsnt Possible statuses are: Prsnt, NotPrsnt, Inactive, or Unprvsnd

The status of the member switch is displayed on the image of the switch. If the member switch appears dimmed, it means the switch is not present, is inactive, or is not provisioned in the Virtual Chassis. If the member switch does not appear dimmed, it means the switch is present and is active.

Table 36 on page 144 describes the possible status of a member switch.

Table 36: Status of a Member Switch in a Virtual Chassis

If the member switch is	It appears as	It means the member switch
Present	Prsnt	Has established physical and logical connections with Virtual Chassis member switches.
Not present	dimmed and NotPrsnt	Has been disconnected from the existing Virtual Chassis.
Inactive	dimmed and Inactive	Has established physical connections, but is unable to establish logical connections.
Not provisioned	dimmed and Unprvsnd	Cannot synchronize with the existing preprovisioned Virtual Chassis.

Click **Rear View** for a graphical view of the rear panel of the switch.

Click **Preferences** to choose which panels must be displayed and set the refresh interval for chassis viewer information. Click **OK** to save your changes and return to the dashboard or click **Cancel** to return to the dashboard without saving changes.

NOTE: You can drag the various panels to different locations in the J-Web window.

System Information Panel

Table 37: System Information

Field	Description
System name	<p>Indicates the local name of the EX Series switch. The local name of the EX Series switches changes when an individual image is clicked.</p> <p>For EX4650 switches, indicates the host name of the switch. Specific host name of the EX4650 switch is displayed when you click on the individual line card.</p>
Device model	<p>Indicates the model of the EX Series switch. In a Virtual Chassis configuration, to indicate the model of a switch, click the image of that switch.</p> <p>NOTE: In a Virtual Chassis setup for an EX6210, EX8208, or EX8216 switch, the Device model field displays details of the primary Routing Engine. To view details of a member, select it.</p> <p>By default, the EX4650 switches show the model of the primary switch. When you click on the image, the model of the switch is displayed.</p>

Table 37: System Information (continued)

Field	Description
Inventory details	

Table 37: System Information (continued)

Field	Description
	<p>Indicates the following:</p> <ul style="list-style-type: none"> • For EX3200 switches; and for EX2200, EX2200-C, EX3300, EX4200, EX4300, EX4500, EX4550, and EX4600 switches that are not configured as Virtual Chassis, the value displayed in Inventory details field is always 1 FPC. FPC is a legacy term for a slot in a large Juniper Networks chassis; which simply refers to the standalone switch. • For EX2200 and EX2200-C switches configured as a Virtual Chassis, the value displayed in the Inventory details field is 1–4 FPC, with the number corresponding to the number of member switches. • For EX3300 switches configured as a Virtual Chassis, the value displayed in the Inventory details field is 1–6 FPC, with the number corresponding to the number of member switches. <p>NOTE: For Junos OS Release 14.1X53-D10 and later, EX3300 switches configured as a Virtual Chassis display the value 1–10 FPC in the Inventory details field.</p> <ul style="list-style-type: none"> • For EX4200, EX4500, EX4550, and EX4600 switches configured as a Virtual Chassis, the value displayed in the Inventory details field is 1–10 FPC, with the number corresponding to the number of member switches. • For EX4650 switches, the value displayed in Inventory details field is equal to the number of FPCs. • For EX6210 switches, the values displayed in the Inventory details field are 1–2 CB and 1–9 FPC. CB, or Control Board, refers to the SRE module. FPC refers to line cards and the FPC within the CB. • For an EX8208 switch, the values displayed in Inventory details field are 1–3 CB and 0–8 FPC. CB, or Control Board, refers to SRE and SF modules. FPC refers to line cards. • For EX8216 switches, the values displayed in Inventory details field are 1–2 CB and 0–16 FPC. CB, or Control Board, refers to RE modules and FPC refers to line cards. • For an XRE200 External Routing Engine in an EX8200 Virtual Chassis, the value displayed in Inventory details is 1 XRE. XRE refers to RE modules. For XRE200

Table 37: System Information (continued)

Field	Description
	External Routing Engines configured as a Virtual Chassis, the values displayed in Inventory details are 1–2 XRE and 0–4 LCC, where LCC refers to the EX8200 line card chassis.
Junos image	Indicates the version of the Junos OS image. In a Virtual Chassis configuration, the Junos OS image of the primary switch is displayed by default. To display the Junos OS image of a specific switch, click the image of that switch. NOTE: For EX4650 switches, the Junos OS image of the primary is displayed by default. To display the Junos OS image of a specific switch, click the image of that switch.
Boot image	Indicates the version of the boot image that is used. In a Virtual Chassis configuration, the boot image of the primary switch is displayed by default. To display the boot image of a specific switch, click the image of that switch. NOTE: For EX4650 switches, the boot image of the primary switch is displayed by default. To display the boot image of a specific switch, click the image of that switch.
Device uptime	Indicates the time since the last reboot. In a Virtual Chassis configuration, to display the uptime of the specific switch, click the image of that switch. NOTE: For EX4650 switches, click the image of the switch to display the uptime.
Last configured time	Indicates the time when the switch was last configured.

Health Status Panel

Table 38: Health Status

Field	Description
EX2200, EX2200-C, EX3200, EX3300, EX4200, and EX4300 Switches	

Table 38: Health Status (continued)

Field	Description
Memory util.	<p>Indicates the memory used in the Routing Engine. In a Virtual Chassis configuration, the memory utilization value of the primary Routing Engine is displayed.</p> <p>NOTE: In EX4300 and EX4600 Virtual Chassis, to display the Routing Engine memory utilization of the primary or backup, click the respective image. J-Web is supported on EX4600 switches only in J-Web Application package Release 14.1X53-A2.</p>
Flash	<p>Indicates the usage and capacity of internal flash memory and any external USB flash drive.</p> <p>NOTE: In EX4300 Virtual Chassis, the flash memory utilization of the primary switch is displayed by default. To display the flash memory utilization along with the internal and external flash memory utilization details for each switch or line card, mouse over individual switch or line card images.</p> <p>In EX4600 Virtual Chassis, to display the flash memory utilization along with the internal and external flash memory utilization details of each switch or line card mouse over the green-colored indicator.</p>
Temp.	<p>Indicates the chassis temperature status. Temperatures are listed in Celsius and the corresponding Fahrenheit values.</p> <p>NOTE: The Temp field is unavailable for a standalone EX2200-C switch.</p> <p>The Temp field is dynamically available for an EX2200 Virtual Chassis switch based on the model of the member clicked.</p> <p>NOTE: In EX4300 Virtual Chassis, the temperature of the primary Routing Engine is displayed by default. To display the temperature of the Routing Engine of any switch, click the image of that switch.</p> <p>In EX4600 Virtual Chassis, to display the temperature of the Routing Engine of each switch, mouse over the green-colored indicator.</p>
CPU load	<p>Indicates the average CPU usage over 15 minutes. In a Virtual Chassis configuration, on loading the primary or backup switch, the CPU load for that switch's Routing Engine is displayed by default. To display the CPU load for a specific switch's Routing Engine, click the image of that switch.</p>

Table 38: Health Status (continued)

Field	Description
Fan status	<p>Indicates the status of the fans in the fan tray. The possible values are OK, Failed, and Absent. In a Virtual Chassis configuration, the fan status of the primary switch is displayed by default. To display the fan status for any switch, click the image of that switch.</p> <p>NOTE: The Fan status field is unavailable for a standalone EX2200-C switch.</p> <p>The Fan status field is dynamically available for an EX2200 Virtual Chassis switch based on the model of the member clicked.</p> <p>In EX4600 Virtual Chassis, mouse over the fan icon to display the fan status of all the switches.</p>
EX4500 and EX4550 Switches	
Memory util.	Indicates the memory used in the Routing Engine. In a Virtual Chassis configuration, the memory utilization value of the primary Routing Engine is displayed.
Flash	Indicates the usage and capacity of internal flash memory and any external USB flash drive.
Temp.	<p>Indicates the chassis temperature status. Temperatures in the dashboard are listed in Celsius and the corresponding Fahrenheit values.</p> <p>NOTE: The Temp field is unavailable for an EX4500 switch.</p>
CPU load	Indicates the average CPU usage over 15 minutes.
Fan status	Indicates the status of the fans in the fan tray. The possible values are OK , Failed , and Absent . This field also indicates the direction of airflow of the fan tray. The possible values are Front to back and Back to front .
EX4650 Switches	
Fan status	<p>Indicates the status of the fans in the fan tray. The possible values are OK, Failed, and Absent.</p> <p>NOTE: The fans are located on the side panel of the chassis.</p>
Temp.	Indicates temperature of the sensor near to Routing Engine.
Memory util.	Indicates the memory used in the Routing Engine.
CPU load	Indicates the average CPU usage over 15 minutes.
EX6210 Switches	

Table 38: Health Status (continued)

Field	Description
Memory util.	Indicates the memory used in the primary Routing Engine. Click the backup Routing Engine to view the memory used in the backup Routing Engine.
CPU load	Indicates the average CPU usage over 15 minutes.
Flash	Indicates the usage and capacity of internal flash memory and any external USB flash drive.
Fan status	Indicates the status of the fans in the fan tray. The possible values are OK , Failed , and Absent .
EX8208 Switches	
Memory util.	Indicates the memory used in the external Routing Engine. In an EX8200 Virtual Chassis, the memory utilization value of the XRE200 External Routing Engine in the primary role is displayed. Click the XRE200 External Routing Engine in the backup role to view the memory used in the backup external Routing Engine.
CPU load	Indicates the average CPU usage over 15 minutes.
Flash	Indicates the usage and capacity of internal flash memory and any external USB flash drive.
EX8216 Switches	
Memory util.	Indicates the memory used in the external Routing Engine. In an EX8200 Virtual Chassis, the memory utilization value of the XRE200 External Routing Engine in the primary role is displayed. Click the XRE200 External Routing Engine in the backup role to view the memory used in the backup external Routing Engine.
CPU load	Indicates the average CPU usage over 15 minutes.
Flash	Indicates the usage and capacity of internal flash memory and any external USB flash drive.
XRE200 External Routing Engines	
Memory util.	Indicates the memory used in the external Routing Engine. In an EX8200 Virtual Chassis, the memory utilization value of the XRE200 External Routing Engine in the primary role is displayed. Click the backup XRE200 External Routing Engine to view the memory used in backup external Routing Engine.
CPU load	Indicates the average CPU usage over 15 minutes.
Flash	Indicates the usage and capacity of internal flash memory and any external USB flash drive.

Table 38: Health Status (*continued*)

Field	Description
Fan Status	Indicates the status of the fans in the fan tray. The possible values are OK , Failed , and Absent .

Capacity Utilization Panel

Table 39: Capacity Utilization

Field	Description
Number of active ports	Indicates the number of active ports in the switch. Configured Virtual Chassis ports (VCPs) are considered as active ports.
Total number of ports	Indicates the number of ports in the switch. NOTE: In EX3300 and EX4600 Virtual Chassis, the total number of ports of all of the switches is displayed. NOTE: For EX4650 switches, on loading the switch, the consolidated values for all the FPCs are displayed by default.
Used-up MAC-Table entries	Indicates the number of MAC table entries.
Supported MAC-Table entries	Indicates the maximum number of MAC table entries permitted. NOTE: For EX4650 switches, the supported maximum number of MAC table entries are 288000.
Number of VLANs configured	Indicates the number of VLANs configured. NOTE: Only tagged VLANs are counted.
Number of VLANs supported	Indicates the maximum number of VLANs supported. NOTE: For EX4650 switches, the supported maximum number of VLANs are 4094.

Alarms Panel

Displays information about the last five alarms raised in the system. For example, if there are 5 major alarms, then details of all 5 major alarms are displayed. If there are 4 major alarms and 3 minor alarms, then details of the 4 major alarms and 1 minor alarm are displayed. Major alarms are displayed in red and minor alarms are displayed in yellow.

In an EX8200 Virtual Chassis, the top 5 alarms for the primary external Routing Engine are displayed by default. If you select an EX8200 member switch of the Virtual Chassis, the top 5 alarms for that member switch are displayed.

File System Usage

To display the file system storage details of a switch in the backup or line card role, click the image of that switch.

For EX4650 switches, the directory, space used, and the file type details are displayed. By default, primary switch file system storage details are displayed. When you click the image, line card switch file system storage details are displayed.

Chassis Viewer

Click the **Rear View** button to see the back of the chassis image. Click the **Front View** button to see the front of the chassis image. In a Virtual Chassis configuration, the **Rear View** button is disabled if the switch is not selected.

NOTE: For EX4650 switches, chassis viewer supports only the standalone view and does not support Virtual Chassis configuration.

- [Table 40 on page 154](#)—Describes the chassis viewer for EX2200 switches.
- [Table 41 on page 154](#)—Describes the chassis viewer for EX2200-C switches.
- [Table 42 on page 155](#)—Describes the chassis viewer for EX3200, EX3300, and EX4200 switches.
- [Table 43 on page 157](#)—Describes the chassis viewer for EX4300 switches.
- [Table 44 on page 159](#)—Describes the chassis viewer for EX4500 switches.
- [Table 45 on page 160](#)—Describes the chassis viewer for EX4550 switches.

- [Table 46 on page 162](#)—Describes the chassis viewer for EX4600 switches.
- [Table 47 on page 163](#)—Describes the chassis viewer for EX4650 switches.
- [Table 48 on page 164](#)—Describes the chassis viewer for EX6210 switches.
- [Table 49 on page 165](#)—Describes the chassis viewer for EX8208 switches.
- [Table 50 on page 166](#)—Describes the chassis viewer for EX8216 switches.
- [Table 51 on page 168](#)—Describes the chassis viewer for the XRE200 External Routing Engines.

Table 40: Chassis Viewer for EX2200 Switches

Field	Description
Front View	
Interface status	<p>In the image, the following colors denote the interface status:</p> <ul style="list-style-type: none"> • Green—Interface is up and operational. • Yellow—Interface is up but is nonoperational. • Gray—Interface is down and nonoperational. <p>Mouse over the interface (port) to view more information.</p>
Rear View	
Management (me0) port	The management port is used to connect the switch to a management device for out-of-band management.
Console port	The console port is used to connect the switch to a management console or to a console server. (You might do this for initial switch configuration.)
USB port	<p>Indicates the USB port for the switch.</p> <p>NOTE: We recommend that you use USB flash drives purchased from Juniper Networks for your EX Series switch.</p>
Fan tray	Mouse over the fan tray icon to display name, status, and description information.
Power supply	Mouse over the power outlet icon to display name, status, and description information.

Table 41: Chassis Viewer for EX2200-C Switches

Field	Description
Front View	

Table 41: Chassis Viewer for EX2200-C Switches (*continued*)

Field	Description
Interface status	<p>In the image, the following colors denote the interface status:</p> <ul style="list-style-type: none"> • Green—Interface is up and operational. • Yellow—Interface is up but is nonoperational. • Gray—Interface is down and nonoperational. <p>Mouse over the interface (port) to view more information.</p>
Management (me0) port	The management port is used to connect the switch to a management device for out-of-band management.
Console port	The console port is used to connect the switch to a management console or to a console server. (You might do this for initial switch configuration.)
USB port	<p>Indicates the USB port for the switch.</p> <p>NOTE: We recommend that you use USB flash drives purchased from Juniper Networks for your EX Series switch.</p>
Rear View	
Power supply	Mouse over the power outlet icon to display name, status, and description information.

Table 42: Chassis Viewer for EX3200, EX3300, and EX4200 Switches

Field	Description
Front View	

Table 42: Chassis Viewer for EX3200, EX3300, and EX4200 Switches (continued)

Field	Description
Interface status	<p>In the image, the following colors denote the interface status:</p> <ul style="list-style-type: none"> • Green—Interface is up and operational. • Yellow—Interface is up but is nonoperational. • Gray—Interface is down and nonoperational. <p>Mouse over the interface (port) to view more information.</p> <p>For a Virtual Chassis configuration, select the switch to view the interface status.</p> <p>If an SFP+ uplink module is installed in the switch, mouse over the port icon to display whether the module is configured to operate in 1-gigabit mode or in 10-gigabit mode. If the module is configured to operate in 1-gigabit mode, the tool tip information is displayed for all 4 ports. If the module is configured to operate in 10-gigabit mode, the tool tip information is displayed only for 2 ports.</p> <p>On an EX3300 switch with the 4x GE/XE SFP+ module, mouse over the port icon to display whether the module is configured to operate in 1-gigabit mode or 10-gigabit mode.</p> <p>For SFP, SFP+, and XFP ports, the interfaces appear dimmed if no transceiver is inserted. The chassis viewer displays Transceiver not plugged-in when you mouse over the port icon.</p>
LCD panel	LCD panel configured for the LEDs on the ports. Mouse over the icon to view the current character display.

Rear View of the EX3200 Switch

Management (me0) port	The management port is used to connect the switch to a management device for out-of-band management.
Console port	The console port is used to connect the switch to a management console or to a console server. (You might do this for initial switch configuration.)
USB port	Indicates the USB port for the switch. NOTE: We recommend that you use USB flash drives purchased from Juniper Networks for your EX Series switch.
Fan tray	Mouse over the fan tray icon to display name, status, and description information.
Power supply	Mouse over the power supply icon to display name, status, and description information.

Rear View of the EX3300 and EX4200 Switch

Table 42: Chassis Viewer for EX3200, EX3300, and EX4200 Switches (continued)

Field	Description
Fan tray	Mouse over the fan tray icon to display name, status, and description information. For a Virtual Chassis, the status of the fans of the selected member switch is displayed.
Virtual Chassis port	Displayed only when EX4200 switches are configured as a Virtual Chassis. The following colors denote the Virtual Chassis port (VCP) status: <ul style="list-style-type: none"> • Green—VCP is up and operational. • Yellow—VCP is up but is nonoperational. • Gray—VCP is down and nonoperational.
USB port	Indicates the USB port for the switch. NOTE: We recommend that you use USB flash drives purchased from Juniper Networks for your EX Series switch.
Management (me0) port	The management port is used to connect the switch to a management device for out-of-band management.
Console port	The console port is used to connect the switch to a management console or to a console server. (You might do this for initial switch configuration.)
Power supplies	Mouse over the power supply icons to display name, status, and description information.

Table 43: Chassis Viewer for EX4300 Switches

Field	Description
Front View	
Interface status	In the image, the colors listed below denote the interface status for both copper and fiber media type of ports: <ul style="list-style-type: none"> • Green—Interface is up and operational. • Yellow—Interface is up but is nonoperational. • Gray—Interface is down and nonoperational. Mouse over the interface (port) to view more information.
LCD panel	LCD panel configured for the LEDs on the ports. Mouse over the icon to view the current character display.
Mini USB console	The mini console port is used to connect the switch to the management console.

Table 43: Chassis Viewer for EX4300 Switches (*continued*)

Field	Description
PIC 2 slot	<p>You can install an uplink module in the PIC 2 slot. Mouse over the ports in the module to view the details of the ports in module.</p> <p>24-port and 48-port EX4300 switches support the 4-port 10-Gigabit SFP+ uplink module.</p> <p>EX4300-32F switches support the 2-port 40-Gigabit QSFP+ uplink module and the 8-port 10-Gigabit SFP+ uplink module.</p> <p>When you install a transceiver in the port, the following colors denote the interface status:</p> <ul style="list-style-type: none"> • Green—Interface is up and operational. • Yellow—Interface is up but is not operational. • Gray—Interface is down and not operational.

NOTE: In EX4300 switches the LEDs are seen in the front panel, these are not active.

Rear View of the EX4300 Switch

Management port	The management port is used to connect the switch to a management device for out-of-band management.
Console port	The Console port (RJ-45) is used to connect the switch to a management console or to a console server.
USB port	<p>Indicates the USB port for the switch.</p> <p>NOTE: We recommend that you use USB flash drives purchased from Juniper Networks for your EX Series switch.</p>
Fan tray	Mouse over the fan tray icons to display name, status, and description information.
Power supplies	Mouse over the power supply icons to display name, status, and description information.

Table 43: Chassis Viewer for EX4300 Switches (continued)

Field	Description
PIC 1 slot	<p>The rear panel of a 24-port and a 48-port EX4300 switch has four (built-in) 40-Gigabit QSFP+ ports, and the rear panel of an EX4300-32F switch has two (built-in) 40-Gigabit QSFP+ ports, in which you can install QSFP+ transceivers. Mouse over the ports to view the details of the ports.</p> <p>After you install a transceiver in the port, the following colors denote the interface status:</p> <ul style="list-style-type: none"> • Green—Interface is up and operational. • Yellow—Interface is up but is not operational. • Gray—Interface is down and not operational. <p>For QSFP+ ports, the interfaces appear dimmed if no transceiver is inserted. The chassis viewer displays Transceiver not plugged in when you mouse over the port.</p> <p>When a QSFP+ port is configured as a Virtual Chassis Port (VCP), the following colors denote the VCP status:</p> <ul style="list-style-type: none"> • Green—VCP is up and operational. • Yellow—VCP is up but is not operational. • Gray—VCP is down and not operational.

Table 44: Chassis Viewer for EX4500 Switches

Field	Description
Front View	
Interface status	<p>In the image, the colors listed below denote the interface status:</p> <ul style="list-style-type: none"> • Green—Interface is up and operational. • Yellow—Interface is up but is nonoperational. • Gray—Interface is down and nonoperational. <p>Mouse over the interface (port) to view more information.</p> <p>For a Virtual Chassis configuration, select the switch to view the interface status.</p> <p>If an SFP+ uplink module is installed in the switch, mouse over the interface (ports) on the module for more information.</p> <p>For SFP and SFP+ ports, the interfaces appear dimmed if no transceiver is inserted. The chassis viewer displays Transceiver not plugged-in when you mouse over the port icon.</p>
LCD panel	LCD panel configured for the LEDs on the ports. Mouse over the icon to view the current character display.

Table 44: Chassis Viewer for EX4500 Switches (*continued*)

Field	Description
Console port	The console port is used to connect the switch to a management console or to a console server.
Management (me0) port	The management port is used to connect the switch to a management device for out-of-band management. Use this port for initial switch configuration.
USB port	Indicates the USB port for the switch. NOTE: We recommend that you use USB flash drives purchased from Juniper Networks for your EX Series switch.

Rear View of the EX4500 Switch

Fan tray	Mouse over the fan tray icon to display status of the fans and airflow direction information. For a Virtual Chassis, the status of the fans of the selected member switch is displayed.
Virtual Chassis port	Displayed only when switches are configured as a Virtual Chassis. The colors listed below denote the Virtual Chassis port (VCP) status: <ul style="list-style-type: none"> • Green—VCP is up and operational. • Yellow—VCP is up but is nonoperational. • Gray—VCP is down and nonoperational.
Power supplies	Mouse over the power supply icons to display name, status, and description information.
Intraconnect module	Mouse over the module to display details of the intraconnect module. The intraconnect module helps the switch achieve line rate on all its ports.
Virtual Chassis module	Mouse over to display details of the switches in the Virtual Chassis configuration.

Table 45: Chassis Viewer for EX4550 Switches

Field	Description
-------	-------------

Front View

Table 45: Chassis Viewer for EX4550 Switches (*continued*)

Field	Description
Interface status	<p>In the image, the colors listed below denote the interface status:</p> <ul style="list-style-type: none"> • Green—Interface is up and operational. • Yellow—Interface is up but is nonoperational. • Gray—Interface is down and nonoperational. <p>Mouse over the interface (port) to view more information.</p> <p>For a Virtual Chassis configuration, select the switch to view the interface status.</p> <p>If an expansion module or a Virtual Chassis module is installed in the switch, mouse over the interface (ports) on the module for more information.</p> <p>On an EX4550-32F switch, for SFP and SFP+ ports, the interfaces appear dimmed if no transceiver is inserted. The chassis viewer displays Transceiver (1G/10G) not plugged in when you mouse over the port icon.</p>
LCD panel	LCD panel configured for the LEDs on the ports. Mouse over the icon to view the current character display.
Console port	The console port is used to connect the switch to a management console or to a console server.
Mini Console port	The mini console port is used to connect the switch to the management console.
Management (me0) port	The management port is used to connect the switch to a management device for out-of-band management. Use this port for initial switch configuration.
PIC1 slot	You can insert an uplink module or a Virtual Chassis module in the PIC1 slot. Mouse over to display the details of the module inserted (uplink or Virtual Chassis).
USB port	<p>Indicates the USB port for the switch.</p> <p>NOTE: We recommend that you use USB flash drives purchased from Juniper Networks for your EX Series switch.</p>
Rear View of the EX4550 Switch	
Fan tray	Mouse over the fan tray icon to display the status of the fans and airflow direction information. For a Virtual Chassis, the status of the fans of the selected member switch is displayed.

Table 45: Chassis Viewer for EX4550 Switches (*continued*)

Field	Description
Virtual Chassis port	<p>Displayed only when switches are configured as a Virtual Chassis. In the image, the colors listed below denote the Virtual Chassis port (VCP) status:</p> <ul style="list-style-type: none"> ● Green—VCP is up and operational. ● Yellow—VCP is up but is nonoperational. ● Gray—VCP is down and nonoperational.
Power supplies	Mouse over the power supply icons to display name, status, and description information.
PIC2 slot	You can insert an uplink module or a Virtual Chassis module into the PIC2 slot. Mouse over to display the details of the module inserted (uplink or Virtual Chassis).

Table 46: Chassis Viewer for EX4600 Switches

Field	Description
Front View	
NOTE: J-Web is supported on EX4600 switches only in J-Web Application package Release 14.1X53-A2.	
Interface status	<p>In the image, the colors listed below denote the interface status for both copper and fiber media type of ports:</p> <ul style="list-style-type: none"> ● Green—Interface is up and operational. ● Yellow—Interface is up but is nonoperational. ● Gray—Interface is down and nonoperational. <p>Mouse over the interface (port) to view more information.</p>
PIC 1 and PIC 2 slots	<p>You can install an expansion module in the PIC 1 and PIC 2 slots. If you have installed an expansion module, mouse over the ports in the module to view the details of the ports in module.</p> <p>When you install a transceiver in the port, the following colors denote the interface status:</p> <ul style="list-style-type: none"> ● Green—Interface is up and operational. ● Yellow—Interface is up but is not operational. ● Gray—Interface is down and not operational.

Table 46: Chassis Viewer for EX4600 Switches (*continued*)

Field	Description
NOTE:	
<ul style="list-style-type: none"> • In EX4600 switches the LEDs are seen in the front panel; these are not active. • In EX4600 switches there is no LCD panel. 	
Rear View of the EX4600 Switch	
Management port	The management ports (RJ-45 and SFP) is used to connect the switch to a management device for out-of-band management.
Console port	The Console port (RJ-45) is used to connect the switch to a management console or to a console server.
USB port	Indicates the USB port for the switch. NOTE: We recommend that you use USB flash drives purchased from Juniper Networks for your EX Series switch.
Fan tray	Mouse over the fan tray icons to display name, status, and description information.
Power supplies	Mouse over the power supply icons to display name, status, and description information.

Table 47: Chassis Viewer for EX4650 Switches

Field	Description
Front View	
SFP28 and QSFP28 Ports	Displays 48 small form-factor pluggable (SFP28) ports and eight 100-Gbps quad small form-factor pluggable (QSFP28) ports. Mouse over the interface (port) to view more information.
Rear View	
Management port	The management port (em0) is used to connect the switch to a management device for out-of-band management.
Virtual Chassis ports	Not supported.
Console port	The Console port (RJ-45) is used to connect the switch to a management console or to a console server.

Table 47: Chassis Viewer for EX4650 Switches (*continued*)

Field	Description
USB port	Indicates the USB port for the switch. NOTE: We recommend that you use USB flash drives purchased from Juniper Networks for your EX Series switch.
Fan Tray	Mouse over the fan tray icons to display name, status, and description information.
Power supply	Mouse over the power supply icon to display name, status, and description information.

Table 48: Chassis Viewer for EX6210 Switches

Field	Description
Front View	
Temperature	Mouse over the temperature icon to display the temperature of the CB or line card.
Interface status	<p>Select the CB or line card.</p> <p>In the image, the colors listed below denote the interface status:</p> <ul style="list-style-type: none"> • Green—Interface is up and operational. • Yellow—Interface is up but is nonoperational. • Gray—Interface is down and nonoperational. <p>Mouse over the interface (port) to view more information.</p> <p>You can view status for the following ports on the SRE module:</p> <ul style="list-style-type: none"> • USB port—Indicates the USB port for the switch. NOTE: We recommend that you use USB flash drives purchased from Juniper Networks for your EX Series switch. • Management (me0) port—The management port is used to connect the switch to a management device for out-of-band management. There are 2 management ports: fiber and copper. The same status is displayed for both the me0 ports. • Console port—The console port is used to connect the switch to a management console or to a console server. (You might do this for initial switch configuration.) <p>CBs support 4 SFP+ uplink ports. Mouse over the interface on the CB for more information.</p> <p>For SFP and SFP+ ports, the interfaces appear dimmed if no transceiver is inserted. The chassis viewer displays Transceiver not plugged-in when you mouse over the port icon.</p>

Table 48: Chassis Viewer for EX6210 Switches (*continued*)

Field	Description
Power supplies	Mouse over the power supply icons to display name, status, and description information.
LCD panel	LCD panel configured for the LEDs on the ports. Mouse over the icon to view the current character display of the primary Routing Engine. The EX6210 switch has 2 LCD panels, one for each Routing Engine. The backup Routing Engine LCD displays Backup .

Rear View of the EX6210 Switch

Fan tray	Mouse over the fan tray icon to display information regarding the cooling fans.
----------	---

Table 49: Chassis Viewer for EX8208 Switches

Field	Description
Front View	
Interface status	<p>In the image, click any line card, SRE module, or SF module to view the front view of the selected component. In the image, the colors listed below denote the interface status:</p> <ul style="list-style-type: none"> • Green—Interface is up and operational. • Yellow—Interface is up but is nonoperational. • Gray—Interface is down and nonoperational. <p>Mouse over the interface (port) to view more information.</p> <p>You can view status for the following ports on the SRE module:</p> <ul style="list-style-type: none"> • USB port—Indicates the USB port for the switch. <p>NOTE: We recommend that you use USB flash drives purchased from Juniper Networks for your EX Series switch.</p> <ul style="list-style-type: none"> • Auxiliary port—This port is unavailable. • Management (me0) port—The management port is used to connect the switch to a management device for out-of-band management. • Console port—The console port is used to connect the switch to a management console or to a console server. (You might do this for initial switch configuration.) <p>Because the SF module has no ports, no status information is displayed.</p>

Table 49: Chassis Viewer for EX8208 Switches (continued)

Field	Description
Slot numbers	Slots on the switch are labeled, from the top of the switch down: <ul style="list-style-type: none"> • 0-3 (line cards) • SRE0, SF, SRE1 (SRE and SF modules) • 4-7 (line cards)
Temperature	The active slots contain a gray temperature icon. Mouse over the icon to display temperature information for the slot.
Fan status	Mouse over the fan tray icon to display name, status, and description information.
Power supplies	Mouse over the power supply icons to display name, status, and description information.
LCD panel	LCD panel configured for the LEDs on the ports. Mouse over the icon to view the current character display.
Rear View	The EX8208 switch does not have any components on the rear of the chassis.

Table 50: Chassis Viewer for EX8216 Switches

Field	Description
Front View	

Table 50: Chassis Viewer for EX8216 Switches (continued)

Field	Description
Interface status	<p>In the image, click any line card or RE module to display the front view of the selected component. In the image, the colors listed below denote the interface status:</p> <ul style="list-style-type: none"> ● Green—Interface is up and operational. ● Yellow—Interface is up but is nonoperational. ● Gray—Interface is down and nonoperational. <p>Mouse over the interface (port) to view more information.</p> <p>You can view status for the following ports on the RE module:</p> <ul style="list-style-type: none"> ● USB port—Indicates the USB port for the switch. <p>NOTE: We recommend that you use USB flash drives purchased from Juniper Networks for your EX Series switch.</p> <ul style="list-style-type: none"> ● Auxiliary port—This port is unavailable. ● Management (me0) port—The management port is used to connect the switch to a management device for out-of-band management. ● Console port—The console port is used to connect the switch to a management console or to a console server. (You might do this for initial switch configuration.)
Slot numbers	<p>Slots on the switch are labeled, from the top of the switch down:</p> <ul style="list-style-type: none"> ● RE0 (RE module) ● RE1 (RE module) ● 0–15 (line cards)
Temperature	<p>The active slots contain a gray temperature icon. Mouse over the icon to display temperature information for the slot.</p>
Fan status	<p>Mouse over the fan tray icon to display consolidated information about the fans.</p>
Power supplies	<p>Mouse over the power supply icons to display name, status, and description information.</p>
LCD panel	<p>LCD panel configured for the LEDs on the ports. Mouse over the icon to view the current character display.</p>
Rear View	
SF modules	<p>Mouse over the SF module icons in their respective slots to display information. Slots are numbered SF7–SF0, from left to right.</p>

Table 51: Chassis Viewer for XRE200 External Routing Engines

Field	Description
Front View	
Interface status	<p>In the image, the colors listed below denote the interface status:</p> <ul style="list-style-type: none"> • Green—Interface is up and operational. • Yellow—Interface is up but is nonoperational. • Gray—Interface is down and nonoperational. <p>Mouse over the interface (port) to view more information.</p> <p>For a Virtual Chassis configuration, select the switch to view the interface status.</p>
Console port	The console port is used to connect the switch to a management console or to a console server.
Management (me0) port	The management port is used to connect the switch to a management device for out-of-band management. Use this port for initial switch configuration.
Virtual Chassis port	<p>In the image, the colors listed below denote the Virtual Chassis port (VCP) status:</p> <ul style="list-style-type: none"> • Green—VCP is up and operational. • Yellow—VCP is up but is nonoperational. • Gray—VCP is down and nonoperational. <p>Mouse over the interface (port) to view more information.</p>
LCD panel	LCD panel configured for the LEDs on the ports. Mouse over the icon to view the current character display.
Temperature	The active slots contain a gray temperature icon. Mouse over the icon to display temperature information for the slot.
USB port	<p>Indicates the USB port for the switch.</p> <p>NOTE: We recommend that you use USB flash drives purchased from Juniper Networks for your EX Series switch.</p>
PIC1 slot	You can install a Virtual Chassis module in the PIC1 slot. Mouse over the Virtual Chassis ports to display the port status details.
PIC2 slot	You can install a Virtual Chassis module in the PIC2 slot. Mouse over the Virtual Chassis ports to display the port status details.

Table 51: Chassis Viewer for XRE200 External Routing Engines (*continued*)

Field	Description
Rear View of the XRE200 External Routing Engine	
Fan modules	Mouse over the fan modules to display status of the fans and airflow direction information. For a Virtual Chassis, the status of the fans of the selected member switch is displayed.
Power supplies	Mouse over the power supply icons to display name, status, and description information.

Release History Table

Release	Description
19.2A1	Starting in J-Web Application Package Release 19.2A1, J-Web supports EX4650 switches.
14.1X53-D10	For Junos OS Release 14.1X53-D10 and later, EX3300 switches configured as a Virtual Chassis display the value 1-10 FPC in the Inventory details field.
14.1X53-A2	In J-Web Application package Release 14.1X53-A2, you can form a Virtual Chassis using EX4600 and EX4300 switches.
14.1X53-A2	J-Web is supported on EX4600 switches only in J-Web Application package Release 14.1X53-A2.

RELATED DOCUMENTATION

J-Web User Interface for EX Series Switches Overview

EX2200 Switches Hardware Overview

EX2300 Switches Hardware Overview

[EX3200 Switches Hardware Overview | 19](#)

EX3300 Switches Hardware Overview

EX4200 Switches Hardware Overview

EX4300 Switches Hardware Overview

EX4500 Switches Hardware Overview

EX6210 Switch Hardware Overview

EX8208 Switch Hardware Overview

EX8216 Switch Hardware Overview

[Check Active Alarms with the J-Web Interface](#) | 204

XRE200 External Routing Engine Hardware Guide

4

CHAPTER

Maintaining Components

Maintaining the EX3200 Cooling System | **172**

Maintaining the EX3200 Power System | **175**

Maintaining the Uplink Module in an EX3200 Switch | **178**

Maintain Transceivers | **183**

Maintain Fiber-Optic Cables | **193**

Maintaining the EX3200 Cooling System

IN THIS SECTION

- [Removing a Fan Tray from an EX3200 Switch | 172](#)
- [Installing a Fan Tray in an EX3200 Switch | 173](#)

Removing a Fan Tray from an EX3200 Switch

EX3200 switches have a single fan tray on the rear panel. The fan tray is a hot-removable and hot-insertable field-replaceable unit (FRU): You can remove and replace it without powering off the switch or disrupting switch functions.

Ensure that you have the following parts and tools available:

- Phillips (+) screwdriver, number 2
- An antistatic bag or an antistatic mat

To remove a fan tray from the switch:

1. Place the antistatic bag or the antistatic mat on a flat, stable surface.
2. Loosen the screw or screws securing the fan tray by using the screwdriver.



WARNING: To avoid injury, do not touch the fan with your hands or any tools as you slide the fan tray out of the chassis—the fan may still be running.

3. Grasp the handle on the fan tray and pull firmly to slide the fan tray halfway out of the chassis.
4. When the fan stops spinning, slide the fan tray completely out of the chassis.
5. Place the fan tray in the antistatic bag or on the antistatic mat placed on a flat, stable surface.

Figure 49: Removing a Fan Tray from an EX3200 Switch

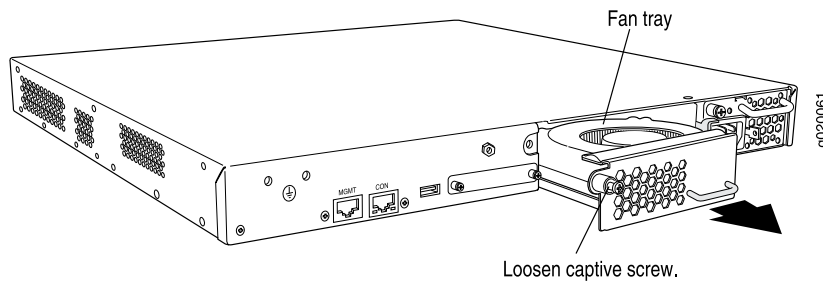

NOTE: When a fan tray is removed, **Fan/Blower is Absent** is logged in the system log and the system raises a minor alarm.

SEE ALSO

[Installing a Fan Tray in an EX3200 Switch | 173](#)

[Installing and Removing EX3200 Switch Hardware Components](#)

[EX3200 Cooling System | 40](#)

[Field-Replaceable Units in EX3200 Switches | 24](#)

[Rear Panel of an EX3200 Switch | 26](#)

Installing a Fan Tray in an EX3200 Switch

EX3200 switches have a single fan tray on the rear panel. The fan tray is a hot-removable and hot-insertable field-replaceable unit (FRU): You can remove and replace it without powering off the switch or disrupting switch functions.

Ensure that you have the following parts and tools available:

- A Phillips (+) screwdriver, number 2

To install a fan tray in an EX3200 switch chassis (see [Figure 50 on page 174](#)):



CAUTION: If you are installing a fan tray in an EX3200 switch, ensure the fan faces upwards.

1. Remove the fan tray from its bag. Using both hands, align the tray with the fan tray guides on the fan tray slot on the rear panel of the chassis and slide it in until it is fully seated.
2. Tighten the screw or screws on the fan tray by using the screwdriver.

Figure 50: Installing a Fan Tray in an EX3200 Switch

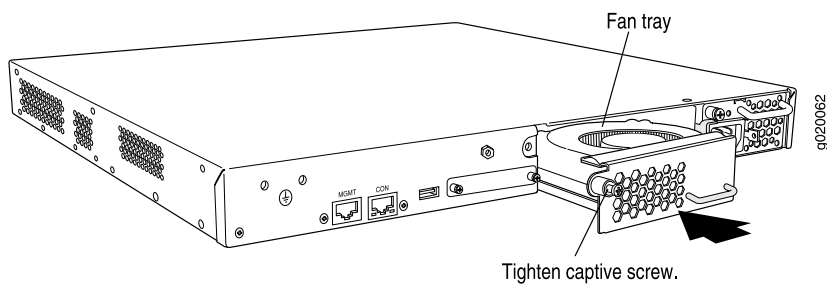

SEE ALSO

[Removing a Fan Tray from an EX3200 Switch | 172](#)

[Installing and Removing EX3200 Switch Hardware Components](#)

[EX3200 Cooling System | 40](#)

[Field-Replaceable Units in EX3200 Switches | 24](#)

[Rear Panel of an EX3200 Switch | 26](#)

Maintaining the EX3200 Power System

IN THIS SECTION

- [Removing a Power Supply from an EX3200 Switch | 175](#)
- [Installing a Power Supply in an EX3200 Switch | 176](#)

Removing a Power Supply from an EX3200 Switch

The power supply in an EX4200 switch is a hot-removable and hot-insertable field-replaceable unit (FRU) located on the rear panel of the switch: You can remove and replace it without powering off the switch or disrupting switch functions.

Ensure that you have the following parts and tools available:

- Phillips (+) screwdriver, number 2
- An antistatic bag or an antistatic mat



CAUTION: Do not leave the power supply slot empty for a long time while the switch is on. The power supply must remain in the chassis for proper airflow.

To remove a power supply from the switch (see [Figure 51 on page 176](#)):

1. Place the antistatic bag or the antistatic mat on a flat, stable surface.
2. Disconnect power to the switch by performing one of the following:
 - AC power supply—If the AC power source outlet has a power switch, set it to the OFF (O) position. If the AC power source outlet does not have a power switch, gently pull out the male end of the power cord connected to the power source outlet.
 - DC power supply—Switch the circuit breaker on the panel board that services the DC circuit to the OFF position.
3. Remove the power source cable from the power supply faceplate:
 - AC power supply—Gently pull out the female end of the power cord connected to the power supply faceplate.

- DC power supply—Remove the screws securing the ring lugs attached to the power source cables to the power supply using the screwdriver, and remove the power source cables from the power supply. Replace the screws on the terminals and tighten them.
4. Loosen the locking lever screw on the left front of the power supply by using the screwdriver.
 5. Push down on the locking lever until it is in its lowest position.
 6. Grasp the power supply handle and pull firmly to slide it halfway out of the chassis.
 7. Place one hand under the power supply to support it and slide it completely out of the chassis. Take care not to touch power supply components, pins, leads, or solder connections.
 8. Place the power supply in the antistatic bag or on the antistatic mat placed on a flat, stable surface.

Figure 51: Removing a Power Supply from the Switch

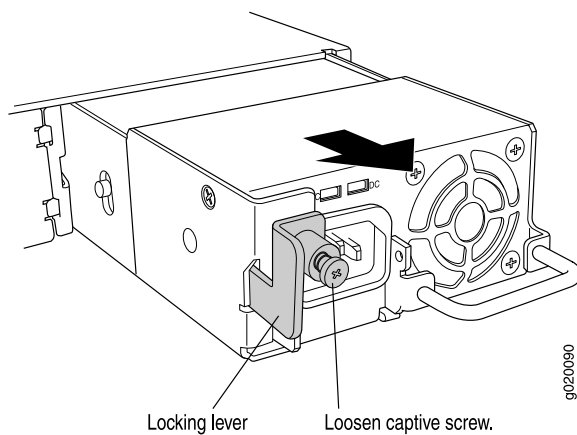

Installing a Power Supply in an EX3200 Switch

The power supply in EX3200 switches is a field-replaceable unit (FRU).

To install a power supply in the switch, ensure that you have the following parts and tools available:

- A Phillips (+) screwdriver, number 2

To install a power supply in the switch (see [Figure 52 on page 177](#)):

1. Taking care not to touch power supply components, pins, leads, or solder connections, remove the power supply from its bag.
2. Loosen the locking lever screw on the left front of the power supply by using the screwdriver.
3. Push down on the locking lever until it is in its lowest position.
4. Using both hands, place the power supply in the power supply slot on the rear panel of the switch and slide it in until it is fully seated.

NOTE: The handle on the 320 W AC power supply is at the bottom of the power supply faceplate, while the handle on the 600 W and the 930 W AC power supplies is at the top of the faceplate. The handle on the 190 W DC power supply runs across the faceplate.

5. Push the locking lever up to its highest position (this action might pull the power supply in).
6. Tighten the locking lever screw by using the screwdriver.

Figure 52: Installing a Power Supply in an EX3200 Switch

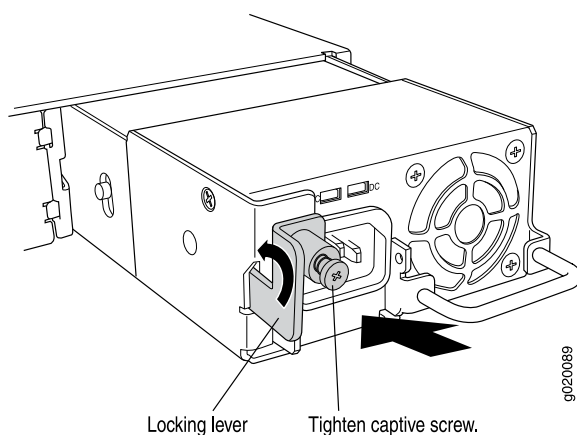

NOTE: The power supply must be connected to a dedicated power source outlet.

NOTE: If you have a Juniper J-Care service contract, register any addition, change, or upgrade of hardware components at <https://www.juniper.net/customers/support/tools/updateinstallbase/> . Failure to do so can result in significant delays if you need replacement parts. This note does not apply if you replace existing components with the same type of component.

Maintaining the Uplink Module in an EX3200 Switch

IN THIS SECTION

- [Removing an Uplink Module from an EX3200 Switch | 178](#)
- [Installing an Uplink Module in an EX3200 Switch | 180](#)

Removing an Uplink Module from an EX3200 Switch

If your EX3200 switch includes an optional uplink module, it is installed in the switch's front panel. The different types of uplink modules are described in [“Uplink Modules in EX3200 Switches” on page 29](#).

The uplink module in EX3200 switches is a hot-removable and hot-insertable unit (FRU): You can remove and replace it without powering off the switch or disrupting switch functions.

Before you begin removing an uplink module from the switch:

- Ensure that you have taken the necessary precautions to prevent ESD damage (see [“Prevention of Electrostatic Discharge Damage” on page 263](#)).
- If there are any transceivers installed in the uplink module, remove them before you remove the uplink module. For instructions on removing transceivers, see [“Remove a Transceiver” on page 183](#).

Ensure that you have the following parts and tools available:

- Electrostatic discharge (ESD) grounding strap (If a grounding strap is not available, follow the alternative grounding method described in Step 1 of the following procedure.)
- Cross-head screwdriver (provided in the uplink module kit)

- An antistatic bag or antistatic mat

To remove an uplink module from the switch:

1. Attach the electrostatic discharge (ESD) grounding strap to your bare wrist, and connect the strap to the ESD point on the chassis.
If a grounding strap is not available, touch the exposed, bare metal of the switch with the other hand to ground yourself and the component.
2. Loosen the screws that secure the flip-up door covering the uplink module slot on the front panel of the switch by using the cross-head screwdriver provided with the uplink module kit and flip the door upward.
3. Insert the ball end of the screwdriver in the keyhole on the front panel of the uplink module and slide the screwdriver to the narrow part of the keyhole (see [Figure 53 on page 179](#)).



CAUTION: Ensure the screwdriver does not slip out of the keyhole when you pull the uplink module out of the switch chassis.

4. Using both hands, gently pull the screwdriver to slide the uplink module halfway out of the chassis (see [Figure 54 on page 180](#)).
5. Place one hand under the uplink module to support it and slide it completely out of the chassis.
6. Slide the screwdriver out of the keyhole.
7. Place the uplink module in an antistatic bag or on an antistatic mat placed on a flat, stable surface.

Figure 53: Sliding the Screwdriver to the Narrow Part of the Keyhole

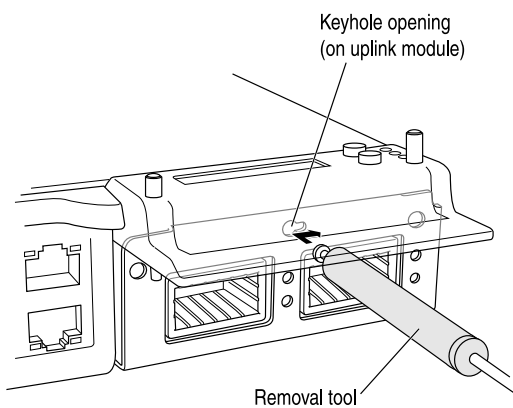
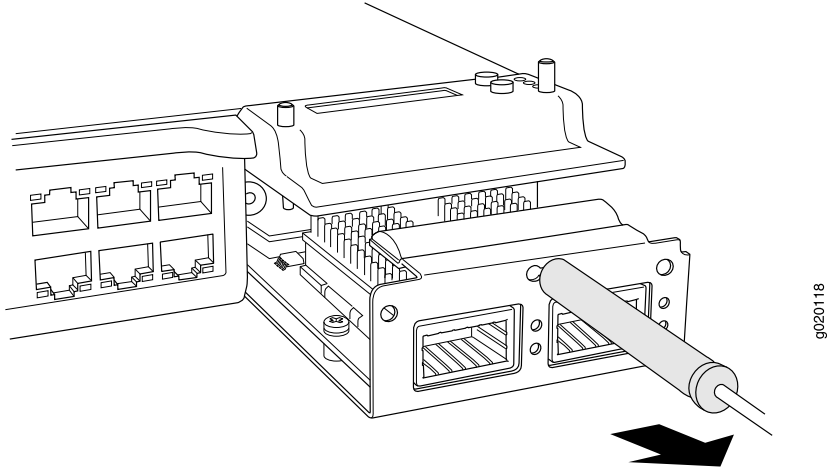

Figure 54: Removing an Uplink Module from an EX3200 Switch



Installing an Uplink Module in an EX3200 Switch

If your EX3200 switch includes an optional uplink module, you install it in the switch's front panel. The different types of uplink modules are described in [“Uplink Modules in EX3200 Switches” on page 29](#).

The uplink module in EX3200 switches is a hot-removable and hot-insertable unit (FRU): You can remove and replace it without powering off the switch or disrupting switch functions.

NOTE: On an EX3200 switch, if you install an SFP uplink module or an SFP+ uplink module when the SFP+ uplink module is operating in the 1-gigabit mode, all the network ports from the last four built-in ports are disabled and remain disabled until you reboot the switch.

On an EX3200 switch, if you install a transceiver in an SFP uplink module or in an SFP+ uplink module when the SFP+ uplink module is operating in the 1-gigabit mode, a corresponding network port from the last four built-in ports is disabled. For example, if you install an SFP or SFP+ transceiver in port 2 on the uplink module (**ge-0/1/2**), then **ge-0/0/22** is disabled. The disabled port is not listed in the output of **show interface** commands.

When an SFP+ uplink module is operating in 10-gigabit mode:

- Only the 10-gigabit ports (ports 0 and 2) are enabled.
- You can use only SFP+ transceivers in those ports.

When an SFP+ uplink module is operating in 1-gigabit mode:

- All four ports are enabled.
- You can use only SFP transceivers in all four ports.

Before you begin installing an uplink module in an EX3200 switch:

- Ensure that you have taken the necessary precautions to prevent ESD damage (see [“Prevention of Electrostatic Discharge Damage” on page 263](#)).

Ensure that you have the following parts and tools available:

- Electrostatic discharge (ESD) grounding strap (If a grounding strap is not available, follow the alternative grounding method described in Step 1 of the following procedure.)
- Cross-head screwdriver (provided in the uplink module kit)

To install an uplink module in the switch (see [Figure 55 on page 182](#)):

1. Attach the electrostatic discharge (ESD) grounding strap to your bare wrist, and connect the strap to the ESD point on the chassis.

If a grounding strap is not available, hold the uplink module in its antistatic bag in one hand and touch the exposed, bare metal of the switch with the other hand to ground yourself and the component.
2. Loosen the screws that secure the flip-up door covering the empty uplink module slot on the front panel of the switch by using the cross-head screwdriver, flip the door upward, and remove the blanking panel covering the empty uplink module slot.

NOTE: If you are removing an uplink module and installing another uplink module, wait for at least 10 seconds after removing the uplink module before installing the new or the same uplink module. If you do not wait for at least 10 seconds, the interfaces on the uplink module might not come up.

3. Taking care not to touch module components, pins, leads, or solder connections, remove the uplink module from its bag.



CAUTION: Before you slide the uplink module into the slot on the switch chassis, ensure the uplink module is aligned correctly. Misalignment might cause the pins to bend, making the uplink module unusable.

4. Using both hands, place the module in the empty slot and slide it in gently until it is fully seated.
5. Flip the door down and tighten the screws by using the cross-head screwdriver.

NOTE: If the switch does not detect the uplink module, see [“Troubleshooting Uplink Module Installation or Replacement on EX3200 Switches”](#) on page 212.

Figure 55: Installing an Uplink Module in an EX3200 Switch

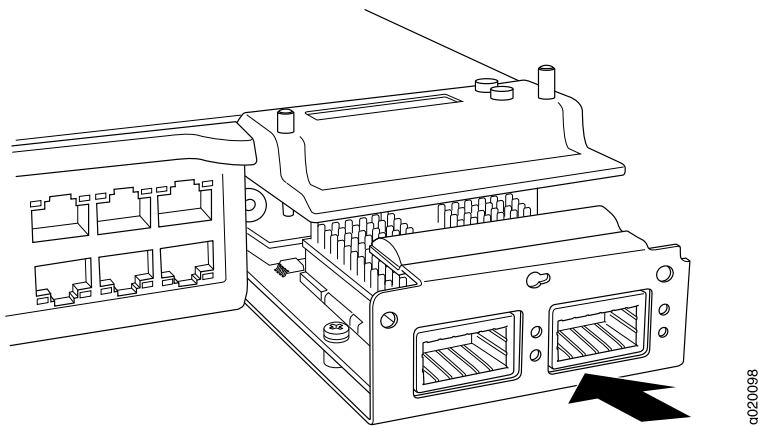

NOTE: If you have a Juniper J-Care service contract, register any addition, change, or upgrade of hardware components at <https://www.juniper.net/customers/support/tools/updateinstallbase/> . Failure to do so can result in significant delays if you need replacement parts. This note does not apply if you replace existing components with the same type of component.

SEE ALSO

| *Configuring Gigabit Ethernet Interfaces (CLI Procedure)*

Maintain Transceivers

IN THIS SECTION

- [Remove a Transceiver | 183](#)
- [Remove a QSFP28 Transceiver | 187](#)
- [Install a Transceiver | 189](#)
- [Install a QSFP28 Transceiver | 191](#)

Remove a Transceiver

The transceivers for Juniper Networks devices are hot-removable and hot-insertable field-replaceable units (FRUs): You can remove and replace them without powering off the device or disrupting device functions.

NOTE: After you remove a transceiver or when you change the media-type configuration, wait for 6 seconds for the interface to display the operational commands.

Before you remove a transceiver from a device, ensure that you have taken the necessary precautions for the safe handling of lasers (see [“Laser and LED Safety Guidelines and Warnings”](#) on page 249).

Ensure that you have the following parts and tools available:

- An antistatic bag or an antistatic mat
- Rubber safety caps to cover the transceiver and fiber-optic cable connector
- A dust cover to cover the port or a replacement transceiver

[Figure 56 on page 186](#) shows how to remove a QSFP+ transceiver. The procedure is the same for all types of transceivers except the QSFP28 and CFP transceivers.

To remove a transceiver from a device:

1. Place the antistatic bag or antistatic mat on a flat, stable surface.
2. Wrap and fasten one end of the ESD wrist strap around your bare wrist, and connect the other end of the strap to the ESD point on the switch.
3. Label the cable connected to the transceiver so that you can reconnect it correctly.



WARNING: Do not look directly into a fiber-optic transceiver or into the ends of fiber-optic cables. Fiber-optic transceivers and fiber-optic cables connected to transceivers emit laser light that can damage your eyes.



WARNING: Do not leave a fiber-optic transceiver uncovered except when inserting or removing a cable. The rubber safety cap keeps the port clean and prevents accidental exposure to laser light.



CAUTION: Do not bend fiber-optic cables beyond their minimum bend radius. An arc smaller than a few inches in diameter can damage the cables and cause problems that are difficult to diagnose.

4. Remove the cable connected to the transceiver (see [“Disconnect a Fiber-Optic Cable”](#) on page 194). Cover the transceiver and the end of each fiber-optic cable connector with a rubber safety cap immediately after disconnecting the fiber-optic cables.

5. If there is a cable management system, arrange the cable in the cable management system to prevent it from dislodging or developing stress points. Secure the cable so that it does not support its own weight as it hangs to the floor. Place excess cable out of the way in a neatly coiled loop in the cable management system. Placing fasteners on the loop helps to maintain its shape.



CAUTION: Do not bend the fiber-optic cable beyond its minimum bend radius. An arc smaller than a few inches in diameter can damage the cable and cause problems that are difficult to diagnose.

6. To remove an SFP, SFP+, XFP, or a QSFP+ transceiver:
 - a. By using your fingers, pull open the ejector lever on the transceiver to unlock the transceiver.



CAUTION: Before removing the transceiver, make sure that you open the ejector lever completely until you hear it click. This prevents damage to the transceiver.

- b. Grasp the transceiver ejector lever and gently slide the transceiver approximately 0.5 in. (1.3 cm) straight out of the port.



CAUTION: To prevent ESD damage to the transceiver, do not touch the connector pins at the end of the transceiver.

Figure 56: Remove a QSFP+ Transceiver

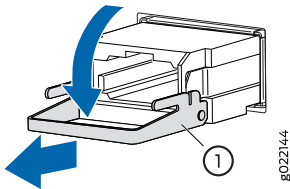

1-Ejector lever

To remove a CFP transceiver:

- a. Loosen the screws on the transceiver by using your fingers.
- b. Grasp the screws on the transceiver and gently slide the transceiver approximately 0.5 in. (1.3 cm) straight out of the port.



CAUTION: To prevent ESD damage to the transceiver, do not touch the connector pins at the end of the transceiver.

7. By using your fingers, grasp the body of the transceiver and pull it straight out of the port.

8. Place the transceiver in the antistatic bag or on the antistatic mat placed on a flat, stable surface.
9. Place the dust cover over the empty port or install the replacement transceiver.

Remove a QSFP28 Transceiver

The transceivers for Juniper Networks devices are hot-removable and hot-insertable field-replaceable units (FRUs). You can remove and replace them without powering off the device or disrupting the device functions.

NOTE: After you insert a transceiver or after you change the media-type configuration, wait for 6 seconds for the interface to display operational commands.

NOTE: We recommend that you use only optical transceivers and optical connectors purchased from Juniper Networks with your Juniper Networks device.

Before you remove a transceiver from a device, ensure that you have taken the necessary precautions for safe handling of lasers (see [“Laser and LED Safety Guidelines and Warnings” on page 249](#)).

Ensure that you have the following parts and tools available:

- An antistatic bag or an antistatic mat
- Rubber safety caps to cover the transceiver and fiber-optic cable connector
- A dust cover to cover the port or a replacement transceiver

To remove a QSFP28 transceiver (see [Figure 57 on page 188](#)):

1. Place an antistatic bag or antistatic mat on a flat, stable surface to receive the QSFP28 transceiver. Have a rubber safety cap ready for the QSFP28 transceiver and the cable.
2. Wrap and fasten one end of an ESD wrist strap around your bare wrist, and connect the other end of the strap to the ESD point on the switch.
3. Label the cable connected to the QSFP28 transceiver so that you can later reconnect it to the correct QSFP28 transceiver.

4. Disconnect the cable from the transceiver. Immediately cover the transceiver and the end of the cable with a rubber safety cap.



CAUTION: Do not leave a fiber-optic transceiver uncovered except when inserting or removing a cable. The safety cap keeps the port clean and prevents accidental exposure to laser light.

5. If there is a cable management system, arrange the cable in the cable management system to prevent it from dislodging or developing stress points. Secure the cable so that it does not support its own weight as it hangs to the floor. Place excess cable out of the way in a neatly coiled loop in the cable management system. Placing fasteners on the loop helps to maintain its shape.



CAUTION: Do not bend the fiber-optic cable beyond its minimum bend radius. An arc smaller than a few inches in diameter can damage the cable and cause problems that are difficult to diagnose.

Figure 57: Remove a QSFP28 Transceiver

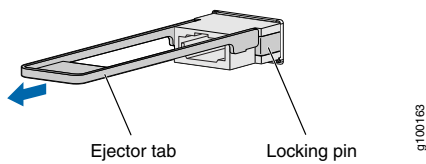

6. Pull the ejector tab straight back. The locking pins on the transceiver automatically release the transceiver.
7. Place the transceiver on the antistatic mat or in the antistatic bag.
8. Place the dust cover over the empty port or install the replacement transceiver.

Install a Transceiver

The transceivers for Juniper Networks devices are hot-removable and hot-insertable field-replaceable units (FRUs): You can remove and replace them without powering off the device or disrupting the device functions.

NOTE: After you insert a transceiver or after you change the media-type configuration, wait for 6 seconds for the interface to display operational commands.

NOTE: We recommend that you use only optical transceivers and optical connectors purchased from Juniper Networks with your Juniper Networks device.



CAUTION: If you face a problem running a Juniper Networks device that uses a third-party optic or cable, the Juniper Networks Technical Assistance Center (JTAC) can help you diagnose the source of the problem. Your JTAC engineer might recommend that you check the third-party optic or cable and potentially replace it with an equivalent Juniper Networks optic or cable that is qualified for the device.

Before you install a transceiver in a device, ensure that you have taken the necessary precautions for safe handling of lasers (see [“Laser and LED Safety Guidelines and Warnings” on page 249](#)).

Ensure that you have a rubber safety cap available to cover the transceiver.

[Figure 45 on page 125](#) shows how to install a QSFP+ transceiver. The procedure is the same for all types of transceivers except the QSFP28 and CFP transceivers.

To install a transceiver:



CAUTION: To prevent electrostatic discharge (ESD) damage to the transceiver, do not touch the connector pins at the end of the transceiver.

1. Wrap and fasten one end of the ESD wrist strap around your bare wrist, and connect the other end of the strap to the ESD point on the switch.
2. Remove the transceiver from its bag.

3. Check to see whether the transceiver is covered with a rubber safety cap. If it is not, cover the transceiver with a rubber safety cap.



WARNING: Do not leave a fiber-optic transceiver uncovered except when inserting or removing a cable. The rubber safety cap keeps the port clean and prevents accidental exposure to laser light.

4. If the port in which you want to install the transceiver is covered with a dust cover, remove the dust cover and save it in case you need to cover the port later. If you are hot-swapping a transceiver, wait for at least 10 seconds after removing the transceiver from the port before installing a new transceiver.
5. Using both hands, carefully place the transceiver in the empty port. The connectors must face the chassis.



CAUTION: Before you slide the transceiver into the port, ensure that the transceiver is aligned correctly. Misalignment might cause the pins to bend, making the transceiver unusable.

6. Slide the transceiver in gently until it is fully seated. If you are installing a CFP transceiver, tighten the captive screws on the transceiver by using your fingers.
7. Remove the rubber safety cap from the transceiver and the end of the cable, and insert the cable into the transceiver.



WARNING: Do not look directly into a fiber-optic transceiver or into the ends of fiber-optic cables. Fiber-optic transceivers and fiber-optic cable connected to a transceiver emit laser light that can damage your eyes.



CAUTION: Do not leave a fiber-optic transceiver uncovered except when inserting or removing cable. The safety cap keeps the port clean and prevents accidental exposure to laser light.

8. If there is a cable management system, arrange the cable in the cable management system to prevent the cable from dislodging or developing stress points. Secure the cable so that it does not support its

own weight as it hangs to the floor. Place excess cable out of the way in a neatly coiled loop in the cable management system. Placing fasteners on the loop helps to maintain its shape.



CAUTION: Do not let fiber-optic cable hang free from the connector. Do not allow fastened loops of cable to dangle, which stresses the cable at the fastening point.



CAUTION: Avoid bending fiber-optic cable beyond its minimum bend radius. An arc smaller than a few inches in diameter can damage the cable and cause problems that are difficult to diagnose.

Figure 58: Install a Transceiver

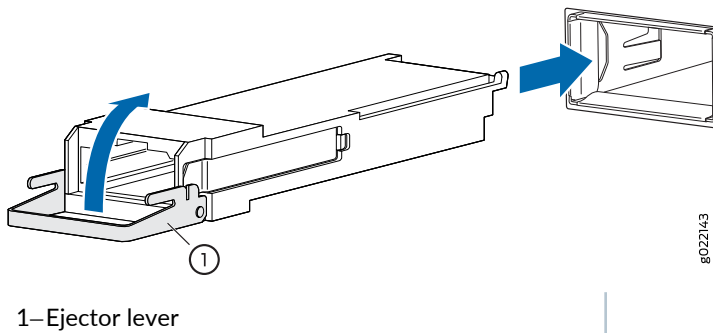

Install a QSFP28 Transceiver

The transceivers for Juniper Networks devices are hot-removable and hot-insertable field-replaceable units (FRUs): You can remove and replace them without powering off the device or disrupting the device functions.

NOTE: After you insert a transceiver or after you change the media-type configuration, wait for 6 seconds for the interface to display operational commands.

NOTE: We recommend that you use only optical transceivers and optical connectors purchased from Juniper Networks with your Juniper Networks device.



CAUTION: If you face a problem running a Juniper Networks device that uses a third-party optic or cable, the Juniper Networks Technical Assistance Center (JTAC) can help you diagnose the source of the problem. Your JTAC engineer might recommend that you check the third-party optic or cable and potentially replace it with an equivalent Juniper Networks optic or cable that is qualified for the device.

Before you install a transceiver in a device, ensure that you have taken the necessary precautions for safe handling of lasers (see [“Laser and LED Safety Guidelines and Warnings”](#) on page 249).

Ensure that you have a rubber safety cap available to cover the transceiver.

To install a QSFP28 transceiver (see [Figure 59](#) on page 192):

1. Wrap and fasten one end of the ESD wrist strap around your bare wrist, and connect the other end of the strap to the ESD point on the switch.
2. Verify that a rubber safety cap covers the QSFP28 transceiver.
3. Orient the transceiver in front of the port so that the QSFP28 connector faces the appropriate direction.

Figure 59: Install a QSFP28 Transceiver

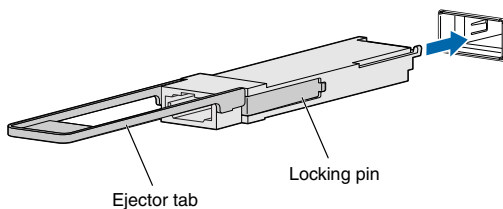

4. Slide the transceiver into the slot until the locking pins lock in place. If there is resistance, remove the transceiver and flip it so that the connector faces the other direction.
5. Remove the rubber safety cap from the transceiver and the end of the cable, and insert the cable into the transceiver.



WARNING: Do not look directly into a fiber-optic transceiver or into the ends of fiber-optic cables. Fiber-optic transceivers and fiber-optic cable connected to a transceiver emit laser light that can damage your eyes.



CAUTION: Do not leave a fiber-optic transceiver uncovered except when inserting or removing cable. The safety cap keeps the port clean and prevents accidental exposure to laser light.

6. If there is a cable management system, arrange the cable in the cable management system to prevent the cable from dislodging or developing stress points. Secure the cable so that it does not support its own weight as it hangs to the floor. Place excess cable out of the way in a neatly coiled loop in the cable management system. Placing fasteners on the loop helps to maintain its shape.



CAUTION: Do not let fiber-optic cable hang free from the connector. Do not allow fastened loops of cable to dangle, which stresses the cable at the fastening point.



CAUTION: Avoid bending fiber-optic cable beyond its minimum bend radius. An arc smaller than a few inches in diameter can damage the cable and cause problems that are difficult to diagnose.

Maintain Fiber-Optic Cables

IN THIS SECTION

- [Connect a Fiber-Optic Cable | 193](#)
- [Disconnect a Fiber-Optic Cable | 194](#)
- [How to Handle Fiber-Optic Cables | 195](#)

Connect a Fiber-Optic Cable

Before you connect a fiber-optic cable to an optical transceiver installed in a device, ensure that you have taken the necessary precautions for safe handling of lasers (see [“Laser and LED Safety Guidelines and Warnings” on page 249](#)).

To connect a fiber-optic cable to an optical transceiver installed in a device:



WARNING: Do not look directly into a fiber-optic transceiver or into the ends of fiber-optic cables. Fiber-optic transceivers and fiber-optic cables connected to transceivers emit laser light that can damage your eyes.

1. If the fiber-optic cable connector is covered with a rubber safety cap, remove the cap. Save the cap.
2. Remove the rubber safety cap from the optical transceiver. Save the cap.
3. Insert the cable connector into the optical transceiver (see [Figure 46 on page 126](#)).

Figure 60: Connect a Fiber-Optic Cable to an Optical Transceiver Installed in a Device

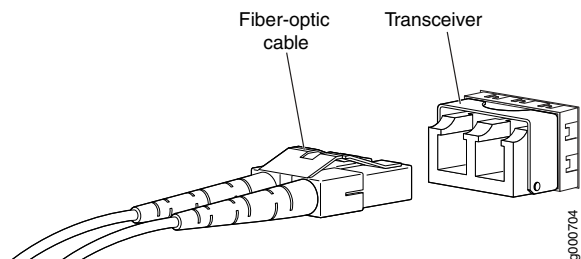

4. Secure the cables so that they do not support their own weight. Place excess cable out of the way in a neatly coiled loop. Placing fasteners on a loop helps cables maintain their shape.



CAUTION: Do not bend fiber-optic cables beyond their minimum bend radius. An arc smaller than a few inches in diameter can damage the cables and cause problems that are difficult to diagnose.

Do not let fiber-optic cables hang free from the connector. Do not allow fastened loops of cables to dangle, which stresses the cables at the fastening point.

Disconnect a Fiber-Optic Cable

Juniper Networks devices have optical transceivers to which you can connect fiber-optic cables.

Before you disconnect a fiber-optic cable from an optical transceiver, ensure that you have taken the necessary precautions for safe handling of lasers. See [“Laser and LED Safety Guidelines and Warnings” on page 249](#).

Ensure that you have the following parts and tools available:

- A rubber safety cap to cover the transceiver
- A rubber safety cap to cover the fiber-optic cable connector

To disconnect a fiber-optic cable from an optical transceiver installed in the device:

1. Disable the port in which the transceiver is installed by issuing the following command:

```
[edit interfaces]  
user@device# set interface-name disable
```



WARNING: Do not look directly into a fiber-optic transceiver or into the ends of fiber-optic cables. Fiber-optic transceivers and fiber-optic cables connected to transceivers emit laser light that can damage your eyes.

2. Carefully unplug the fiber-optic cable connector from the transceiver.
3. Cover the transceiver with a rubber safety cap.



WARNING: Do not leave a fiber-optic transceiver uncovered except when inserting or removing a cable. The rubber safety cap keeps the port clean and prevents accidental exposure to laser light.

4. Cover the fiber-optic cable connector with the rubber safety cap.

How to Handle Fiber-Optic Cables

Fiber-optic cables connect to optical transceivers that are installed in Juniper Networks devices.

To maintain fiber-optic cables:

- When you unplug a fiber-optic cable from a transceiver, place rubber safety caps over the transceiver and on the end of the cable.
- Anchor fiber-optic cables to prevent stress on the connectors. When attaching a fiber-optic cable to a transceiver, be sure to secure the fiber-optic cable so that it does not support its own weight as it hangs to the floor. Never let a fiber-optic cable hang free from the connector.
- Avoid bending fiber-optic cables beyond their minimum bend radius. Bending fiber-optic cables into arcs smaller than a few inches in diameter can damage the cables and cause problems that are difficult to diagnose.
- Frequent plugging and unplugging of fiber-optic cables in and out of optical instruments can damage the instruments, which are expensive to repair. Attach a short fiber extension to the optical equipment. Any wear and tear due to frequent plugging and unplugging is then absorbed by the short fiber extension, which is easier and less expensive to replace than the instruments.
- Keep fiber-optic cable connections clean. Microdeposits of oil and dust in the canal of the transceiver or cable connector can cause loss of light, reduction in signal power, and possibly intermittent problems with the optical connection.
 - To clean the transceiver canal, use an appropriate fiber-cleaning device such as RIFOCS Fiber Optic Adaptor Cleaning Wands (part number 946). Follow the instructions in the cleaning kit you use.
 - After cleaning the transceiver, make sure that the connector tip of the fiber-optic cable is clean. Use only an approved alcohol-free fiber-optic cable cleaning kit such as the Opptex Cletop-S Fiber Cleaner. Follow the instructions in the cleaning kit you use.

5

CHAPTER

Troubleshooting Hardware

Troubleshooting EX3200 Components | **198**

Troubleshooting EX3200 Components

IN THIS SECTION

- Understand Alarm Types and Severity Levels on EX Series Switches | 198
- Chassis Component Alarm Conditions on EX3200 Switches | 200
- Check Active Alarms with the J-Web Interface | 204
- Monitor System Log Messages | 205
- Troubleshooting Network Interfaces on EX3200 Switches | 210
- Troubleshooting Uplink Module Installation or Replacement on EX3200 Switches | 212
- Troubleshooting PoE Voltage Injection Failure in EX2300, EX3400, or EX4300 Switch Models with PoE Capability | 213
- Troubleshoot Temperature Alarms in EX Series Switches | 213

Understand Alarm Types and Severity Levels on EX Series Switches

NOTE: This topic applies only to the J-Web Application package.

Alarms alert you to conditions that might prevent normal operation of the switch. Before monitoring alarms on a Juniper Networks EX Series Ethernet switch, become familiar with the terms defined in [Table 52 on page 198](#).

Table 52: Alarm Terms

Term	Definition
alarm	Signal alerting you to conditions that might prevent normal operation. On a switch, the alarm signal is the ALM LED lit on the front of the chassis.
alarm condition	Failure event that triggers an alarm.
alarm severity	Seriousness of the alarm. If the Alarm (ALM) LED is red, this indicates a major alarm. If the Alarm LED is yellow or amber, this indicates a minor alarm. If the Alarm LED is unlit, there is no alarm or the switch is halted.

Table 52: Alarm Terms (*continued*)

Term	Definition
chassis alarm	Preset alarm triggered by a physical condition on the switch such as a power supply failure, excessive component temperature, or media failure.
system alarm	Preset alarm triggered by a missing rescue configuration or failure to install a license for a licensed software feature. NOTE: On EX6200 switches, a system alarm can be triggered by an internal link error.

Alarm Types

The switch supports these alarms:

- Chassis alarms indicate a failure on the switch or one of its components. Chassis alarms are preset and cannot be modified.
- System alarms indicate a missing rescue configuration. System alarms are preset and cannot be modified, although you can configure them to appear automatically in the J-Web interface display or the CLI display.

Alarm Severity Levels

Alarms on switches have two severity levels:

- Major (red)—Indicates a critical situation on the switch that has resulted from one of the following conditions. A red alarm condition requires immediate action.
 - One or more hardware components have failed.
 - One or more hardware components have exceeded temperature thresholds.
 - An alarm condition configured on an interface has triggered a critical warning.
- Minor (yellow or amber)—Indicates a noncritical condition on the switch that, if left unchecked, might cause an interruption in service or degradation in performance. A yellow or amber alarm condition requires monitoring or maintenance.

A missing rescue configuration generates a yellow or amber system alarm.

SEE ALSO

[Dashboard for EX Series Switches | 142](#)

Chassis Component Alarm Conditions on EX3200 Switches

This topic describes the chassis component alarm conditions on EX3200 switches.

Table 53 on page 200 lists the alarms that the chassis components can generate on EX3200 switches, their severity levels, and the actions you can take to respond to them.

Table 53: Chassis Component Alarm Conditions on EX3200 Switches

Chassis Component	Alarm Condition	Alarm Severity	Remedy
Power supplies	A power supply has been removed from the chassis.	Minor (yellow)	Install a power supply.
	An unknown power supply is installed.	Minor (yellow)	Install a power supply recommended by Juniper Networks.
	The power supply is offline or the power supply output has failed.	Major (red)	Open a support case using the Case Manager link at https://www.juniper.net/support/ or call 1-888-314-5822 (toll-free within the United States and Canada) or 1-408-745-9500 (from outside the United States).
Fan tray	Fan tray is not installed.	Minor (yellow)	Install the fan tray.
	One fan in the chassis is not spinning or is spinning at below the required speed.	Major (red)	<ul style="list-style-type: none"> • Check the fan. • Replace the faulty fan tray. • If the above two checks show no problems, open a support case using the Case Manager link at https://www.juniper.net/support/ or call 1-888-314-5822 (toll-free within the United States and Canada) or 1-408-745-9500 (from outside the United States).
	Fan failure-i2c read failure.	Major (red)	<ul style="list-style-type: none"> • Check the fan. • Replace the faulty fan tray. • If the above two checks show no problems, open a support case using the Case Manager link at https://www.juniper.net/support/ or call 1-888-314-5822 (toll-free within the United States and Canada) or 1-408-745-9500 (from outside the United States).

Table 53: Chassis Component Alarm Conditions on EX3200 Switches (*continued*)

Chassis Component	Alarm Condition	Alarm Severity	Remedy
Temperature	The temperature inside the chassis has exceeded 203° F (95° C).	Major (red)	<ul style="list-style-type: none"> • Check the fan. • Open a support case using the Case Manager link at https://www.juniper.net/support/ or call 1-888-314-5822 (toll-free within the United States and Canada) or 1-408-745-9500 (from outside the United States).
	The temperature inside the chassis has exceeded 185° F (85° C) and a fan has failed.	Major (red)	<ul style="list-style-type: none"> • Replace the fan tray. • Open a support case using the Case Manager link at https://www.juniper.net/support/ or call 1-888-314-5822 (toll-free within the United States and Canada) or 1-408-745-9500 (from outside the United States).
	The temperature inside the chassis has exceeded 176° F (80° C).	Minor (yellow)	<ul style="list-style-type: none"> • Check the fan. • Open a support case using the Case Manager link at https://www.juniper.net/support/ or call 1-888-314-5822 (toll-free within the United States and Canada) or 1-408-745-9500 (from outside the United States).
	The temperature inside the chassis has exceeded 158° F (70° C) and a fan has failed.	Minor (yellow)	<ul style="list-style-type: none"> • Replace the fan tray. • Open a support case using the Case Manager link at https://www.juniper.net/support/ or call 1-888-314-5822 (toll-free within the United States and Canada) or 1-408-745-9500 (from outside the United States).
	The temperature sensor has failed.	Major (red)	Open a support case using the Case Manager link at https://www.juniper.net/support/ or call 1-888-314-5822 (toll-free within the United States and Canada) or 1-408-745-9500 (from outside the United States).

Table 53: Chassis Component Alarm Conditions on EX3200 Switches (continued)

Chassis Component	Alarm Condition	Alarm Severity	Remedy
Media	Device booted from backup root.	Minor (yellow)	Open a support case using the Case Manager link at https://www.juniper.net/support/ or call 1-888-314-5822 (toll-free within the United States and Canada) or 1-408-745-9500 (from outside the United States).
	/var or /config full (only 10% free).	Major (red)	Open a support case using the Case Manager link at https://www.juniper.net/support/ or call 1-888-314-5822 (toll-free within the United States and Canada) or 1-408-745-9500 (from outside the United States).
	/var or /config full (only 25% free).	Minor (yellow)	Open a support case using the Case Manager link at https://www.juniper.net/support/ or call 1-888-314-5822 (toll-free within the United States and Canada) or 1-408-745-9500 (from outside the United States).
	Upgrade bank is empty or corrupted.	Major (red)	Open a support case using the Case Manager link at https://www.juniper.net/support/ or call 1-888-314-5822 (toll-free within the United States and Canada) or 1-408-745-9500 (from outside the United States).
	Firmware version is not the latest.	Minor (yellow)	Open a support case using the Case Manager link at https://www.juniper.net/support/ or call 1-888-314-5822 (toll-free within the United States and Canada) or 1-408-745-9500 (from outside the United States).
	Single-bit ECC error detected.	Major (red)	Open a support case using the Case Manager link at https://www.juniper.net/support/ or call 1-888-314-5822 (toll-free within the United States and Canada) or 1-408-745-9500 (from outside the United States).

Table 53: Chassis Component Alarm Conditions on EX3200 Switches (*continued*)

Chassis Component	Alarm Condition	Alarm Severity	Remedy
Redundant power system (RPS)	RPS is disconnected.	Major (red)	Check the RPS connection.
	RPS fan has failed.	Major (red)	Open a support case using the Case Manager link at https://www.juniper.net/support/ or call 1-888-314-5822 (toll-free within the United States and Canada) or 1-408-745-9500 (from outside the United States).
	RPS power supply has failed.	Major (red)	Open a support case using the Case Manager link at https://www.juniper.net/support/ or call 1-888-314-5822 (toll-free within the United States and Canada) or 1-408-745-9500 (from outside the United States).
	RPS is backing up the switch for the first time.	Minor (yellow)	Check the reason for power supply failure.
Management Ethernet interface	Management Ethernet link is down.	Major (red)	<ul style="list-style-type: none"> • Check whether a cable is connected to the management Ethernet interface, or whether the cable is defective. Replace the cable if required. • If you are unable to resolve the problem, open a support case using the Case Manager link at https://www.juniper.net/support/ or call 1-888-314-5822 (toll-free within the United States and Canada) or 1-408-745-9500 (from outside the United States).

Table 53: Chassis Component Alarm Conditions on EX3200 Switches (*continued*)

Chassis Component	Alarm Condition	Alarm Severity	Remedy
Routing Engine	/var partition usage is high.	Minor (yellow)	Clean up the system file storage space on the switch. For more information, see <i>Freeing Up System Storage Space</i> .
	/var partition is full.	Major (red)	Clean up the system file storage space on the switch. For more information, see <i>Freeing Up System Storage Space</i> .
	Rescue configuration is not set.	Minor (yellow)	Use the request system configuration rescue save command to set the rescue configuration.
	Feature usage requires a license or the license for the feature usage has expired.	Minor (yellow)	Install the required license for the feature specified in the alarm. For more information, see <i>Understanding Software Licenses for EX Series Switches</i> .

Check Active Alarms with the J-Web Interface

Purpose

NOTE: This topic applies only to the J-Web Application package.

Use the monitoring functionality to view alarm information for the EX Series switches including alarm type, alarm severity, and a brief description for each active alarm on the switching platform.

Action

To view the active alarms:

1. Select **Monitor > Events and Alarms > View Alarms** in the J-Web interface.
2. Select an alarm filter based on alarm type, severity, description, and date range.
3. Click **Go**.

All the alarms matching the filter are displayed.

NOTE: When the switch is reset, the active alarms are displayed.

Meaning

Table 54 on page 205 lists the alarm output fields.

Table 54: Summary of Key Alarm Output Fields

Field	Values
Type	Category of the alarm: <ul style="list-style-type: none"> • Chassis—Indicates an alarm condition on the chassis (typically an environmental alarm such as one related to temperature). • System—Indicates an alarm condition in the system.
Severity	Alarm severity—either major (red) or minor (yellow or amber).
Description	Brief synopsis of the alarm.
Time	Date and time when the failure was detected.

SEE ALSO

[Monitor System Log Messages | 205](#)

[Dashboard for EX Series Switches | 142](#)

[Understand Alarm Types and Severity Levels on EX Series Switches | 198](#)

Monitor System Log Messages

Purpose

NOTE: This topic applies only to the J-Web Application package.

Use the monitoring functionality to filter and view system log messages for EX Series switches.

Action

To view events in the J-Web interface, select **Monitor > Events and Alarms > View Events**.

Apply a filter or a combination of filters to view messages. You can use filters to display relevant events. [Table 55 on page 206](#) describes the different filters, their functions, and the associated actions.

To view events in the CLI, enter the following command:

```
show log
```

Table 55: Filtering System Log Messages

Field	Function	Your Action
System Log File	<p>Specifies the name of a system log file for which you want to display the recorded events.</p> <p>Lists the names of all the system log files that you configure.</p> <p>By default, a log file, messages, is included in the /var/log/ directory.</p>	<p>To specify events recorded in a particular file, select the system log filename from the list— for example, messages.</p> <p>Select Include archived files to include archived files in the search.</p>
Process	<p>Specifies the name of the process generating the events you want to display.</p> <p>To view all the processes running on your system, enter the CLI command show system processes.</p> <p>For more information about processes, see the Junos OS Installation and Upgrade Guide.</p>	<p>To specify events generated by a process, type the name of the process.</p> <p>For example, type mgd to list all messages generated by the management process.</p>
Date From To	<p>Specifies the time period in which the events you want displayed are generated.</p> <p>Displays a calendar that allows you to select the year, month, day, and time. It also allows you to select the local time.</p> <p>By default, the messages generated during the last one hour are displayed. End Time shows the current time and Start Time shows the time one hour before End Time.</p>	<p>To specify the time period:</p> <ul style="list-style-type: none"> Click the Calendar icon and select the year, month, and date— for example, 02/10/2007. Click the Calendar icon and select the year, month, and date— for example, 02/10/2007. Click to select the time in hours, minutes, and seconds.

Table 55: Filtering System Log Messages (continued)

Field	Function	Your Action
Event ID	<p>Specifies the event ID for which you want to display the messages.</p> <p>Allows you to type part of the ID and completes the remainder automatically.</p> <p>An event ID, also known as a system log message code, uniquely identifies a system log message. It begins with a prefix that indicates the generating software process or library.</p>	<p>To specify events with a specific ID, type the partial or complete ID— for example, TFTPD_AF_ERR.</p>
Description	<p>Specifies text from the description of events that you want to display.</p> <p>Allows you to use regular expressions to match text from the event description.</p> <p>NOTE: Regular expression matching is case-sensitive.</p>	<p>To specify events with a specific description, type a text string from the description with regular expression.</p> <p>For example, type ^Initial* to display all messages with lines beginning with the term <i>Initial</i>.</p>
Search	<p>Applies the specified filter and displays the matching messages.</p>	<p>To apply the filter and display messages, click Search.</p>
Reset	<p>Resets all the fields in the Events Filter box.</p>	<p>To reset the field values that are listed in the Events Filter box, click Reset.</p>

Table 55: Filtering System Log Messages (continued)

Field	Function	Your Action
<p>Generate Raw Report</p> <p>NOTE:</p> <ul style="list-style-type: none"> Starting in Junos OS Release 14.1X53, a Raw Report can be generated from the log messages being loaded in the Events Detail table. The Generate Raw Report button is enabled after the event log messages start loading in the Events Detail table. After the log messages are completely loaded in the Events Detail table, Generate Raw Report changes to Generate Report. 	<p>Generates a list of event log messages in nontabular format.</p>	<p>To generate a raw report:</p> <ol style="list-style-type: none"> Click Generate Raw Report. <p>The <i>Opening filteredEvents.html</i> window appears.</p> <ol style="list-style-type: none"> Select Open with to open the HTML file or select Save File to save the file. Click OK.
<p>Generate Report</p> <p>NOTE: Starting in Junos OS Release 14.1X53, a Formatted Report can be generated from event log messages being loaded in an Events Detail table. The Generate Report button appears only after event log messages are completely loaded in the Events Detail table. The Generate Raw Report button is displayed while event log messages are being loaded.</p>	<p>Generates a list of event log messages in tabular format, which shows system details, events filter criteria, and event details.</p>	<p>To generate a formatted report:</p> <ol style="list-style-type: none"> Click Generate Report. <p>The <i>Opening Report.html</i> window appears.</p> <ol style="list-style-type: none"> Select Open with to open the HTML file or select Save File to save the file. Click OK.

Meaning

Table 56 on page 209 describes the Event Summary fields.

NOTE: By default, the View Events page in the J-Web interface displays the most recent 25 events, with severity levels highlighted in different colors. After you specify the filters, Event Summary displays the events matching the specified filters. Click the **First**, **Next**, **Prev**, and **Last** links to navigate through messages.

Table 56: Viewing System Log Messages

Field	Function	Additional Information
Process	Displays the name and ID of the process that generated the system log message.	The information displayed in this field is different for messages generated on the local Routing Engine than for messages generated on another Routing Engine (on a system with two Routing Engines installed and operational). Messages from the other Routing Engine also include the identifiers re0 and re1 that identify the Routing Engine.
Severity	<p>Severity level of a message is indicated by different colors.</p> <ul style="list-style-type: none"> ● Unknown—Gray—Indicates no severity level is specified. ● Debug/Info/Notice—Green—Indicates conditions that are not errors but are of interest or might warrant special handling. ● Warning—Yellow or Amber—Indicates conditions that warrant monitoring. ● Error—Blue—Indicates standard error conditions that generally have less serious consequences than errors in the emergency, alert, and critical levels. ● Critical—Pink—Indicates critical conditions, such as hard-drive errors. ● Alert—Orange—Indicates conditions that require immediate correction, such as a corrupted system database. ● Emergency—Red—Indicates system panic or other conditions that cause the switch to stop functioning. 	A severity level indicates how seriously the triggering event affects switch functions. When you configure a location for logging a facility, you also specify a severity level for the facility. Only messages from the facility that are rated at that level or higher are logged to the specified file.

Table 56: Viewing System Log Messages (continued)

Field	Function	Additional Information
Event ID	<p>Displays a code that uniquely identifies the message.</p> <p>The prefix on each code identifies the message source, and the rest of the code indicates the specific event or error.</p>	<p>The event ID begins with a prefix that indicates the generating software process.</p> <p>Some processes on a switch do not use codes. This field might be blank in a message generated from such a process.</p> <p>An event can belong to one of the following type categories:</p> <ul style="list-style-type: none"> • Error—Indicates an error or failure condition that might require corrective action. • Event—Indicates a condition or occurrence that does not generally require corrective action.
Event Description	Displays a more detailed explanation of the message.	
Time	Displays the time at which the message was logged.	

SEE ALSO

[Check Active Alarms with the J-Web Interface | 204](#)

[Understand Alarm Types and Severity Levels on EX Series Switches | 198](#)

Troubleshooting Network Interfaces on EX3200 Switches

This topic provides troubleshooting information for specific problems related to interfaces on EX3200 switches.

- The interface on one of the last four built-in network ports in an EX3200 switch (for example, interface ge-0/0/23) is down | [211](#)
- The interface on the port in which an SFP or SFP+ transceiver is installed in an SFP+ uplink module is down | [211](#)

The interface on one of the last four built-in network ports in an EX3200 switch (for example, interface ge-0/0/23) is down

Problem

Description: The interface on one of the last four built-in ports (ge-0/0/20 through ge-0/0/23 on 24-port models or ge-0/0/44 through ge-0/0/47 on 48-port models) of an EX3200 switch is down.

Environment: An SFP or SFP+ uplink module is installed in the switch and a transceiver is installed in one of the ports on the uplink module.

Symptoms: When you check the status with the CLI command *show interfaces ge* or with the J-Web user interface, the disabled port is not listed.

Cause

The last four built-in ports use the same ASIC as the SFP uplink module. Therefore, if you install a transceiver in an SFP or SFP+ uplink module installed in an EX3200 switch, a corresponding base port from the last four built-in ports is disabled.

Solution

If you need to use the disabled built-in port, you must remove the transceiver from the SFP or SFP+ uplink module. Alternatively, you can install an XFP uplink module instead of an SFP or SFP+ uplink module. There is no conflict between the built-in network ports and the ports on the XFP uplink modules.

The interface on the port in which an SFP or SFP+ transceiver is installed in an SFP+ uplink module is down

Problem

Description: The interface on the port in which an SFP or SFP+ transceiver is installed in an SFP+ uplink module installed in an EX3200 switch is down.

Symptoms: When you check the status with the CLI command *show interfaces ge* or with the J-Web user interface, the disabled port is not listed.

Cause

By default, the SFP+ uplink module operates in the 10-gigabit mode and supports only SFP+ transceivers. The operating mode for the module is incorrectly set.

Solution

Either SFP+ or SFP transceivers can be installed in SFP+ uplink modules. You must configure the operating mode of the SFP+ uplink module to match the type of transceiver you want to use. For SFP+ transceivers, configure the 10-gigabit operating mode and for SFP transceivers, configure the 1-gigabit operating mode. See *Setting the Mode on an SFP+ or SFP+ MACSec Uplink Module* .

Troubleshooting Uplink Module Installation or Replacement on EX3200 Switches

This topic provides troubleshooting information for specific problems related to uplink module ports on EX3200 switches.

1. [One of the last four network ports on an EX3200 switch with an SFP or SFP+ uplink module installed is disabled | 212](#)
2. [A port on an SFP uplink module installed in an EX3200 switch is disabled | 212](#)

One of the last four network ports on an EX3200 switch with an SFP or SFP+ uplink module installed is disabled

Problem

Description: One of the last four built-in ports (**ge-0/0/20** through **ge-0/0/23** on 24-port models or **ge-0/0/44** through **ge-0/0/47** on 48-port models) of an EX3200 switch with an SFP or SFP+ uplink module installed in it is disabled.

Symptoms: When you check the status with the CLI command **show interfaces ge** or with the J-Web user interface, the disabled port is not listed.

Cause

The last four built-in ports use the same ASIC as the SFP uplink module. Therefore, if you install a transceiver in an SFP or SFP+ uplink module installed in an EX3200 switch, a corresponding base port from the last four built-in ports is disabled.

Solution

If you need to use the disabled built-in port, you must remove the transceiver from the SFP or SFP+ uplink module. Alternatively, you can install an XFP uplink module instead of an SFP or SFP+ uplink module. There is no conflict between the built-in network ports and the ports on the XFP uplink modules.

A port on an SFP uplink module installed in an EX3200 switch is disabled

Problem

Description: One of the ports (**ge-0/1/0** through **ge-0/1/3**) of an SFP uplink module installed in an EX3200 switch is disabled.

Symptoms: When you check the status with the **show interface** commands or with the J-Web user interface, the disabled port is not listed.

Cause

If you replace a transceiver multiple times in quick succession in a port in an SFP uplink module installed in an EX3200 switch, it might cause an eeprom read problem. The switch might not create an interface for that port and that port might be disabled.

Solution

To enable the disabled uplink module port, remove the transceiver from that port and install it after 10 seconds.

SEE ALSO

| [Remove a Transceiver](#) | 183

Troubleshooting PoE Voltage Injection Failure in EX2300, EX3400, or EX4300 Switch Models with PoE Capability

Problem

Description: Devices that draw power from EX2300, EX3400, or EX4300 switch models with Power over Ethernet (PoE) capability do not get power from those switches. The problem persists after rebooting the switches or upgrading to the latest version of Junos OS.

Environment: EX2300, EX3400, or EX4300 switch models with PoE capability are connected to EX2200, EX3200, or EX4200 switch models with PoE capability by using RJ-45 network ports.

Solution

When you connect EX2300, EX3400, or EX4300 switch models with PoE capability to EX2200, EX3200, or EX4200 switch models with PoE capability by using RJ-45 network ports, disable PoE on all the RJ-45 network ports used to connect the switches using the command:

```
user@device> set poe interface interface-name disable
```

SEE ALSO

| [Understanding PoE on EX Series Switches](#)

Troubleshoot Temperature Alarms in EX Series Switches

Problem

Description: EX Series switches generate a temperature alarm **FPC 0 EX-PFE1 Temp Too Hot**.

Cause

Temperature sensors in the chassis monitor the temperature of the chassis. The switch raises an alarm if a fan fails or if the temperature of the chassis exceeds permissible levels.

Solution

When the switch raises a temperature alarm such as the **FPC 0 EX-PFE1 Temp Too Hot** alarm, use the **show chassis environment** and the **show chassis temperature-thresholds** commands to identify the condition that triggered the alarm.



CAUTION: To prevent the switch from overheating, do not operate it in an area that exceeds the maximum recommended ambient temperature. To prevent airflow restriction, allow at least 6 inches (15.2 cm) of clearance around the ventilation openings.

1. Connect to the switch by using Telnet and issue the **show chassis environment** command. This command displays environmental information about the switch chassis, including the temperature, and information about the fans, power supplies, and Routing Engines. Following is a sample output on an EX9208 switch. The output is similar on other EX Series switches.

```
user@switch> show chassis environment
```

Class	Item	Status	Measurement
Temp	PEM 0	OK	40 degrees C / 104 degrees F
	PEM 1	OK	40 degrees C / 104 degrees F
	PEM 2	Absent	
	PEM 3	Absent	
	Routing Engine 0	OK	37 degrees C / 98 degrees F
	Routing Engine 0 CPU	OK	35 degrees C / 95 degrees F
	Routing Engine 1	Absent	
	Routing Engine 1 CPU	Absent	
	CB 0 Intake	OK	36 degrees C / 96 degrees F
	CB 0 Exhaust A	OK	34 degrees C / 93 degrees F
	CB 0 Exhaust B	OK	40 degrees C / 104 degrees F
	CB 0 ACBC	OK	39 degrees C / 102 degrees F
	CB 0 XF A	OK	46 degrees C / 114 degrees F
	CB 0 XF B	OK	45 degrees C / 113 degrees F
	CB 1 Intake	Absent	
	CB 1 Exhaust A	Absent	
	CB 1 Exhaust B	Absent	
	CB 1 ACBC	Absent	

	CB 1 XF A	Absent	
	CB 1 XF B	Absent	
	FPC 3 Intake	OK	48 degrees C / 118 degrees F
	FPC 3 Exhaust A	OK	46 degrees C / 114 degrees F
	FPC 3 Exhaust B	OK	51 degrees C / 123 degrees F
	FPC 3 XL TSen	OK	67 degrees C / 152 degrees F
	FPC 3 XL Chip	OK	58 degrees C / 136 degrees F
	FPC 3 XL_XR0 TSen	OK	67 degrees C / 152 degrees F
	FPC 3 XL_XR0 Chip	OK	51 degrees C / 123 degrees F
	FPC 3 XL_XR1 TSen	OK	67 degrees C / 152 degrees F
	FPC 3 XL_XR1 Chip	OK	63 degrees C / 145 degrees F
	FPC 3 XQ TSen	OK	67 degrees C / 152 degrees F
	FPC 3 XQ Chip	OK	63 degrees C / 145 degrees F
	FPC 3 XQ_XR0 TSen	OK	67 degrees C / 152 degrees F
	FPC 3 XQ_XR0 Chip	OK	68 degrees C / 154 degrees F
	FPC 3 XM TSen	OK	67 degrees C / 152 degrees F
	FPC 3 XM Chip	OK	76 degrees C / 168 degrees F
	FPC 3 XF TSen	OK	67 degrees C / 152 degrees F
	FPC 3 XF Chip	OK	75 degrees C / 167 degrees F
	FPC 3 PLX PCIe Switch TSe	OK	51 degrees C / 123 degrees F
	FPC 3 PLX PCIe Switch Chi	OK	54 degrees C / 129 degrees F
	FPC 3 Aloha FPGA 0 TSen	OK	51 degrees C / 123 degrees F
	FPC 3 Aloha FPGA 0 Chip	OK	70 degrees C / 158 degrees F
	FPC 3 Aloha FPGA 1 TSen	OK	51 degrees C / 123 degrees F
	FPC 3 Aloha FPGA 1 Chip	OK	75 degrees C / 167 degrees F
	FPC 5 Intake	Testing	
	FPC 5 Exhaust A	Testing	
	FPC 5 Exhaust B	Testing	
Fans	Top Rear Fan	OK	Spinning at intermediate-speed
	Bottom Rear Fan	OK	Spinning at intermediate-speed
	Top Middle Fan	OK	Spinning at intermediate-speed
	Bottom Middle Fan	OK	Spinning at intermediate-speed
	Top Front Fan	OK	Spinning at intermediate-speed
	Bottom Front Fan	OK	Spinning at intermediate-speed

Table 57 on page 216 lists the output fields for the **show chassis environment** command. Output fields are listed in the approximate order in which they appear.

Table 57: show chassis environment Output Fields

Field Name	Field Description
Class	Information about the category or class of chassis component: <ul style="list-style-type: none"> • Temp: Temperature of air flowing through the chassis in degrees Celsius (°C) and degrees Fahrenheit (°F). • Fans: Information about the status of fans and blowers.
Item	Information about the chassis components: Flexible PIC Concentrators (FPCs)—that is, the line cards—, Control Boards (CBs), Routing Engines (REs), Power Entry Modules (PEMs)—that is, the power supplies.
Status	Status of the specified chassis component. For example, if Class is Fans , the fan status can be: <ul style="list-style-type: none"> • OK: The fans are operational. • Testing: The fans are being tested during initial power-on. • Failed: The fans have failed or the fans are not spinning. • Absent: The fan tray is not installed.
Measurement	Depends on the Class. For example, if Class is Temp , indicates the temperature in degrees Celsius (°C) and degrees Fahrenheit (°F). If the Class is Fans , indicates actual fan RPM.

- Issue the command **show chassis temperature-thresholds**. This command displays the chassis temperature threshold settings. Following is a sample output on an EX9208 switch. The output is similar on other EX Series switches.

```
user@ host> show chassis temperature-thresholds
```

Item	Fan speed (degrees C)		Yellow alarm (degrees C)		Red alarm (degrees C)		Fire Shutdown (degrees C)
	Normal	High	Normal	Bad fan	Normal	Bad fan	Normal
Chassis default	48	54	65	55	80	65	100
Routing Engine 0	70	80	95	95	110	110	112
FPC 3	55	60	75	65	105	80	110
FPC 5	55	60	75	65	90	80	95

Table 58 on page 217 lists the output fields for the **show chassis temperature-thresholds** command. Output fields are listed in the approximate order in which they appear.

Table 58: show chassis temperature-thresholds Output Fields

Field Name	Field Description
Item	Chassis component. You can configure for the threshold information for components such as the chassis and the Routing Engines to be displayed in the output. By default, information is displayed only for the chassis and the Routing Engines.
Fan speed	Temperature thresholds, in degrees Celsius, for the fans to operate at normal and at high speed. <ul style="list-style-type: none"> • Normal—The temperature threshold at which the fans operate at normal speed and when all the fans are operating. • High—The temperature threshold at which the fans operate at high speed or when a fan has failed. <p>NOTE: An alarm is not triggered until the temperature exceeds the threshold settings for a yellow or red alarm.</p>
Yellow or amber alarm	Temperature threshold, in degrees Celsius, that trigger a yellow or amber alarm. <ul style="list-style-type: none"> • Normal—The temperature threshold that must be exceeded on the component to trigger a yellow or amber alarm. • Bad fan—The temperature threshold that must be exceeded on the component to trigger a yellow or amber alarm.
Red alarm	Temperature threshold, in degrees Celsius, that trigger a red alarm. <ul style="list-style-type: none"> • Normal—The temperature threshold that must be exceeded on the component to trigger a red alarm. • Bad fan—The temperature threshold that must be exceeded on the component to trigger a red alarm.
Fire Shutdown	Temperature threshold, in degrees Celsius, for the switch to shut down.

When a temperature alarm is triggered, you can identify the condition that triggered it by running the **show chassis environment** command to display the chassis temperature values for each component and comparing those with the temperature threshold values, which you can display by running the **show chassis temperature-thresholds** command.

For example, for **FPC 3**:

- If the temperature of **FPC 3** exceeds 55° C, the output indicates that the fans are operating at a high speed (no alarm is triggered).
- If the temperature of **FPC 3** exceeds 65° C, a yellow alarm is triggered to indicate that one or more fans have failed.
- If the temperature of **FPC 3** exceeds 75° C, a yellow alarm is triggered to indicate that the temperature threshold limit is exceeded.
- If the temperature of **FPC 3** exceeds 80° C, a red alarm is triggered to indicate that one or more fans have failed.
- If the temperature of **FPC 3** exceeds 105° C, a red alarm is triggered to indicate that the temperature threshold limit is exceeded.
- If the temperature of **FPC 3** exceeds 110° C, the switch is powered off.

Table 59 on page 218 lists the possible causes for the switch to generate a temperature alarm and the respective remedies.

Table 59: Causes and Remedies for Temperature Alarms

Cause	Remedy
Ambient temperature is above threshold temperature.	Ensure that the ambient temperature is within the threshold temperature limit. See "Environmental Requirements and Specifications for EX Series Switches" on page 55.
Fan module or fan tray has failed.	<ul style="list-style-type: none"> • Check the fan. • Replace the faulty fan module or fan tray. • If the above two checks show no problems, open a support case using the Case Manager link at https://www.juniper.net/support/ or call 1-888-314-5822 (toll-free within the United States and Canada) or 1-408-745-9500 (from outside the United States).
Restricted airflow through the switch due to insufficient clearance around the installed switch.	Ensure that there is sufficient clearance around the installed switch. See the following topics to understand the clearance requirements of various EX Series switches.



CHAPTER

Contacting Customer Support and Returning the Chassis or Components

[Returning an EX3200 Switch or Component for Repair or Replacement](#) | 220

Returning an EX3200 Switch or Component for Repair or Replacement

IN THIS SECTION

- [Returning an EX3200 Switch or Component for Repair or Replacement | 220](#)
- [Locating the Serial Number on an EX3200 Switch or Component | 221](#)
- [Contact Customer Support to Obtain Return Material Authorization | 222](#)
- [Packing an EX3200 Switch or Component for Shipping | 223](#)

Returning an EX3200 Switch or Component for Repair or Replacement

If you need to return a switch or hardware component to Juniper Networks for repair or replacement, follow this procedure:

1. Determine the serial number of the component. For instructions, see [“Locating the Serial Number on an EX3200 Switch or Component” on page 221](#).
2. Obtain an RMA number from JTAC as described in [“Contact Customer Support to Obtain Return Material Authorization” on page 222](#).

NOTE: Do not return any component to Juniper Networks unless you have first obtained an RMA number. Juniper Networks reserves the right to refuse shipments that do not have an RMA. Refused shipments are returned to the customer through collect freight.

3. Pack the switch or component for shipping as described in [“Packing an EX3200 Switch or Component for Shipping” on page 223](#).

For more information about return and repair policies, see the customer support page at <https://www.juniper.net/support/guidelines.html>.

Locating the Serial Number on an EX3200 Switch or Component

IN THIS SECTION

- [Listing the Switch and Components Details with the CLI | 221](#)
- [Locating the Chassis Serial Number ID Label on an EX3200 Switch | 222](#)
- [Locating the Serial Number ID Labels on FRUs in an EX3200 Switch | 222](#)

If you are returning a switch or hardware component to Juniper Networks for repair or replacement, you must locate the serial number of the switch or component. You must provide the serial number to the Juniper Networks Technical Assistance Center (JTAC) when you contact them to obtain Return Materials Authorization (RMA).

If the switch is operational and you can access the CLI, you can list serial numbers for the switch and for some components with a CLI command. If you do not have access to the CLI or if the serial number for the component does not appear in the command output, you can locate the serial number ID label on the physical switch or component (see [Figure 61 on page 222](#)).

NOTE: If you want to find the serial number on the physical switch component, you will need to remove the component from the switch chassis, for which you must have the required parts and tools available.

Listing the Switch and Components Details with the CLI

To list the switch and switch components and their serial numbers, enter the following CLI command:

```
user@switch> show chassis hardware
```

```
Hardware inventory:
Item          Version  Part number  Serial number  Description
Chassis                               BH0208375304  EX3200-24T
Routing Engine 0 REV 11  750-021261  BH0208375304  EX3200-24T, 8 POE
FPC 0         REV 11  750-021261  BH0208375304  EX3200-24T, 8 POE
  CPU                               BUILTIN      BUILTIN      FPC CPU
  PIC 0                               BUILTIN      BUILTIN      24x 10/100/1000 Base-T
```

Power Supply 0	REV 03	740-020957	AT0508285661	PS 320W AC
Fan Tray				Fan Tray

Locating the Chassis Serial Number ID Label on an EX3200 Switch

EX3200 switches have serial number ID labels located on the rear panel of the chassis (see [Figure 61 on page 222](#)).

Figure 61: Location of the Serial Number ID Label on an EX3200 Switch

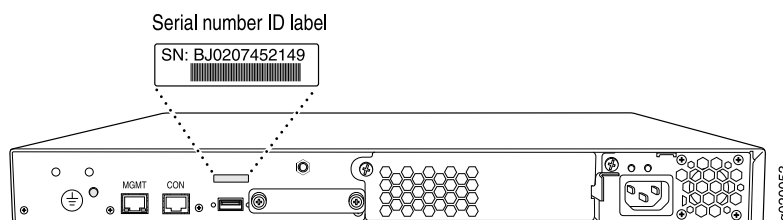

Locating the Serial Number ID Labels on FRUs in an EX3200 Switch

The power supplies, fan trays, and uplink modules installed in EX Series switches are field-replaceable units (FRUs).

For each of these FRUs, you must remove the FRU from the switch chassis to see the FRU's serial number ID label.

- **Power Supply**—The serial number ID label is on the top of the power supply. See [“Removing a Power Supply from an EX3200 Switch” on page 175](#).
- **Fan tray**—The serial number ID label is on the back of the fan tray. See [“Removing a Fan Tray from an EX3200 Switch” on page 172](#).
- **Uplink module**—The serial number ID label is on the circuit board. See [“Removing an Uplink Module from an EX3200 Switch” on page 178](#).

Contact Customer Support to Obtain Return Material Authorization

If you are returning a device or hardware component to Juniper Networks for repair or replacement, obtain a Return Material Authorization (RMA) number from Juniper Networks Technical Assistance Center (JTAC).

After locating the serial number of the device or hardware component you want to return, open a service request with Juniper Networks Technical Assistance Center (JTAC) on the Web or by telephone.

Before you request an RMA number from JTAC, be prepared to provide the following information:

- Your existing service request number, if you have one
- Serial number of the component
- Your name, organization name, telephone number, fax number, and shipping address
- Details of the failure or problem
- Type of activity being performed on the device when the problem occurred
- Configuration data displayed by one or more **show** commands

You can contact JTAC 24 hours a day, seven days a week on the Web or by telephone:

- Service Request Manager: <https://support.juniper.net/support>
- Telephone: +1-888-314-JTAC (+1-888-314-5822), toll free in U.S., Canada, and Mexico

NOTE: For international or direct-dial options in countries without toll free numbers, see <https://support.juniper.net/support>

If you are contacting JTAC by telephone, enter your 12-digit service request number followed by the pound (#) key for an existing case, or press the star (*) key to be routed to the next available support engineer.

The support representative validates your request and issues an RMA number for return of the component.

Packing an EX3200 Switch or Component for Shipping

IN THIS SECTION

- [Packing an EX3200 Switch for Shipping | 225](#)
- [Packing EX3200 Switch Components for Shipping | 225](#)

If you are returning an EX3200 switch or component to Juniper Networks for repair or replacement, pack the item as described in this topic.

Before you begin packing the switch or component:

- Ensure that you have retrieved the original shipping carton and packing materials. Contact your JTAC representative if you do not have these materials, to learn about approved packing materials. See [“Contact Customer Support to Obtain Return Material Authorization”](#) on page 222.

Ensure that you have the following parts and tools available:

- Antistatic bag, one for each switch or component
- Phillips (+) screwdriver, number 2

Packing an EX3200 Switch for Shipping

To pack a switch for shipping:

1. On the console or other management device connected to the switch, enter the CLI operational mode and issue the following command to shut down the switch software:

```
user@switch> request system halt
```

Wait until a message appears on the console confirming that the operating system has halted.

2. Disconnect power from the switch by performing one of the following:
 - If the power source outlet has a power switch, set it to the OFF (0) position.
 - If the power source outlet does not have a power switch, gently pull out the plug end of the power cord connected to the power source outlet.
3. Remove the cables that connect the switch to all external devices. See [“Disconnect a Fiber-Optic Cable” on page 194](#).
4. Remove all field-replaceable units (FRUs) from the switch.
5. If the switch is installed on a wall, rack, or cabinet, have one person support the weight of the switch while another person unscrews and removes the mounting screws.
6. Remove the switch from the wall, rack, cabinet, or desk and place the switch in an antistatic bag.
7. Place the switch in the shipping carton.
8. Place the packing foam on top of and around the switch.
9. If you are returning accessories or FRUs with the switch, pack them as instructed in the following section.
10. Replace the accessory box on top of the packing foam.
11. Close the top of the cardboard shipping box and seal it with packing tape.
12. Write the RMA number on the exterior of the box to ensure proper tracking.

Packing EX3200 Switch Components for Shipping



CAUTION: Do not stack switch components. Return individual components in separate boxes if they do not fit together on one level in the shipping box.

To pack and ship switch components:

- Place individual boards in antistatic bags.
- Ensure that the components are adequately protected with packing materials and packed so that the pieces are prevented from moving around inside the carton.
- Close the top of the cardboard shipping box and seal it with packing tape.
- Write the RMA number on the exterior of the box to ensure proper tracking.

7

CHAPTER

Safety and Compliance Information

General Safety Guidelines and Warnings | **229**

Definitions of Safety Warning Levels | **230**

Qualified Personnel Warning | **233**

Warning Statement for Norway and Sweden | **234**

Fire Safety Requirements | **234**

Installation Instructions Warning | **236**

Chassis and Component Lifting Guidelines | **236**

Restricted Access Warning | **238**

Ramp Warning | **240**

Rack-Mounting and Cabinet-Mounting Warnings | **241**

Grounded Equipment Warning | **247**

Radiation from Open Port Apertures Warning | **248**

Laser and LED Safety Guidelines and Warnings | **249**

Maintenance and Operational Safety Guidelines and Warnings | **252**

General Electrical Safety Guidelines and Warnings | **261**

Action to Take After an Electrical Accident | **262**

Prevention of Electrostatic Discharge Damage | **263**

AC Power Electrical Safety Guidelines | **264**

AC Power Disconnection Warning | **266**

DC Power Electrical Safety Guidelines | **267**

DC Power Disconnection Warning | **268**

DC Power Grounding Requirements and Warning | **270**

DC Power Wiring Sequence Warning | **272**

DC Power Wiring Terminations Warning | **275**

Multiple Power Supplies Disconnection Warning | **278**

TN Power Warning | **279**

Agency Approvals for EX Series Switches | **279**

Compliance Statements for EMC Requirements for EX Series Switches | **280**

Compliance Statements for Acoustic Noise for EX Series Switches | **285**

General Safety Guidelines and Warnings

The following guidelines help ensure your safety and protect the device from damage. The list of guidelines might not address all potentially hazardous situations in your working environment, so be alert and exercise good judgment at all times.

- Perform only the procedures explicitly described in the hardware documentation for this device. Make sure that only authorized service personnel perform other system services.
- Keep the area around the device clear and free from dust before, during, and after installation.
- Keep tools away from areas where people could trip over them while walking.
- Do not wear loose clothing or jewelry, such as rings, bracelets, or chains, which could become caught in the device.
- Wear safety glasses if you are working under any conditions that could be hazardous to your eyes.
- Do not perform any actions that create a potential hazard to people or make the equipment unsafe.
- Never attempt to lift an object that is too heavy for one person to handle.
- Never install or manipulate wiring during electrical storms.
- Never install electrical jacks in wet locations unless the jacks are specifically designed for wet environments.
- Operate the device only when it is properly grounded.
- Follow the instructions in this guide to properly ground the device to earth.
- Replace fuses only with fuses of the same type and rating.
- Do not open or remove chassis covers or sheet-metal parts unless instructions are provided in the hardware documentation for this device. Such an action could cause severe electrical shock.
- Do not push or force any objects through any opening in the chassis frame. Such an action could result in electrical shock or fire.
- Avoid spilling liquid onto the chassis or onto any device component. Such an action could cause electrical shock or damage the device.
- Avoid touching uninsulated electrical wires or terminals that have not been disconnected from their power source. Such an action could cause electrical shock.
- Some parts of the chassis, including AC and DC power supply surfaces, power supply unit handles, SFB card handles, and fan tray handles might become hot. The following label provides the warning of the hot surfaces on the chassis:



- Always ensure that all modules, power supplies, and cover panels are fully inserted and that the installation screws are fully tightened.

Definitions of Safety Warning Levels

The documentation uses the following levels of safety warnings (there are two *Warning* formats):

NOTE: You might find this information helpful in a particular situation, or you might overlook this important information if it was not highlighted in a Note.



CAUTION: You need to observe the specified guidelines to prevent minor injury or discomfort to you or severe damage to the device.

Attention Veillez à respecter les consignes indiquées pour éviter toute incommodité ou blessure légère, voire des dégâts graves pour l'appareil.



WARNING: This symbol alerts you to the risk of personal injury from a laser.

Avertissement Ce symbole signale un risque de blessure provoquée par rayon laser.



WARNING: This symbol means danger. You are in a situation that could cause bodily injury. Before you work on any equipment, be aware of the hazards involved with electrical circuitry and be familiar with standard practices for preventing accidents.

Waarschuwing Dit waarschuwingssymbool betekent gevaar. U verkeert in een situatie die lichamelijke letsels kan veroorzaken. Voordat u aan enige apparatuur gaat werken, dient u zich bewust te zijn van de bij elektrische schakelingen betrokken risico's en dient u op de hoogte te zijn van standaard maatregelen om ongelukken te voorkomen.

Varoitus Tämä varoitusmerkki merkitsee vaaraa. Olet tilanteessa, joka voi johtaa ruumiinvammaan. Ennen kuin työskentelet minkään laitteiston parissa, ota selvää sähkökytkentöihin liittyvistä vaaroista ja tavanomaisista onnettomuuksien ehkäisykeinoista.

Avertissement Ce symbole d'avertissement indique un danger. Vous vous trouvez dans une situation pouvant causer des blessures ou des dommages corporels. Avant de travailler sur un équipement, soyez conscient des dangers posés par les circuits électriques et familiarisez-vous avec les procédures couramment utilisées pour éviter les accidents.

Warnung Dieses Warnsymbol bedeutet Gefahr. Sie befinden sich in einer Situation, die zu einer Körperverletzung führen könnte. Bevor Sie mit der Arbeit an irgendeinem Gerät beginnen, seien Sie sich der mit elektrischen Stromkreisen verbundenen Gefahren und der Standardpraktiken zur Vermeidung von Unfällen bewußt.

Avvertenza Questo simbolo di avvertenza indica un pericolo. La situazione potrebbe causare infortuni alle persone. Prima di lavorare su qualsiasi apparecchiatura, occorre conoscere i pericoli relativi ai circuiti elettrici ed essere al corrente delle pratiche standard per la prevenzione di incidenti.

Advarsel Dette varselsymbolet betyr fare. Du befinner deg i en situasjon som kan føre til personskade. Før du utfører arbeid på utstyr, må du være oppmerksom på de faremomentene som elektriske kretser innebærer, samt gjøre deg kjent med vanlig praksis når det gjelder å unngå ulykker.

Aviso Este símbolo de aviso indica perigo. Encontra-se numa situação que lhe poderá causar danos físicos. Antes de começar a trabalhar com qualquer equipamento, familiarize-se com os perigos relacionados com circuitos eléctricos, e com quaisquer práticas comuns que possam prevenir possíveis acidentes.

¡Atención! Este símbolo de aviso significa peligro. Existe riesgo para su integridad física. Antes de manipular cualquier equipo, considerar los riesgos que entraña la corriente eléctrica y familiarizarse con los procedimientos estándar de prevención de accidentes.

Varning! Denna varningssymbol signalerar fara. Du befinner dig i en situation som kan leda till personskada. Innan du utför arbete på någon utrustning måste du vara medveten om farorna med elkretsar och känna till vanligt förfarande för att förebygga skador.

Qualified Personnel Warning



WARNING: Only trained and qualified personnel should install or replace the device.

Waarschuwing Installatie en reparaties mogen uitsluitend door getraind en bevoegd personeel uitgevoerd worden.

Varoitus Ainoastaan koulutettu ja pätevä henkilökunta saa asentaa tai vaihtaa tämän laitteen.

Avertissement Tout installation ou remplacement de l'appareil doit être réalisé par du personnel qualifié et compétent.

Warnung Gerät nur von geschultem, qualifiziertem Personal installieren oder auswechseln lassen.

Avvertenza Solo personale addestrato e qualificato deve essere autorizzato ad installare o sostituire questo apparecchio.

Advarsel Kun kvalifisert personell med riktig opplæring bør montere eller bytte ut dette utstyret.

Aviso Este equipamento deverá ser instalado ou substituído apenas por pessoal devidamente treinado e qualificado.

¡Atención! Estos equipos deben ser instalados y reemplazados exclusivamente por personal técnico adecuadamente preparado y capacitado.

Varning! Denna utrustning ska endast installeras och bytas ut av utbildad och kvalificerad personal.

Warning Statement for Norway and Sweden



WARNING: The equipment must be connected to an earthed mains socket-outlet.

Advarsel Apparatet skal kobles til en jordet stikkontakt.

Varning! Apparatet skall anslutas till jordat nätuttag.

Fire Safety Requirements

In the event of a fire emergency, the safety of people is the primary concern. You should establish procedures for protecting people in the event of a fire emergency, provide safety training, and properly provision fire-control equipment and fire extinguishers.

In addition, you should establish procedures to protect your equipment in the event of a fire emergency. Juniper Networks products should be installed in an environment suitable for electronic equipment. We recommend that fire suppression equipment be available in the event of a fire in the vicinity of the equipment and that all local fire, safety, and electrical codes and ordinances be observed when you install and operate your equipment.

Fire Suppression

In the event of an electrical hazard or an electrical fire, you should first turn power off to the equipment at the source. Then use a Type C fire extinguisher, which uses noncorrosive fire retardants, to extinguish the fire.

Fire Suppression Equipment

Type C fire extinguishers, which use noncorrosive fire retardants such as carbon dioxide and Halotron™, are most effective for suppressing electrical fires. Type C fire extinguishers displace oxygen from the point of combustion to eliminate the fire. For extinguishing fire on or around equipment that draws air from the environment for cooling, you should use this type of inert oxygen displacement extinguisher instead of an extinguisher that leaves residues on equipment.

Do not use multipurpose Type ABC chemical fire extinguishers (dry chemical fire extinguishers). The primary ingredient in these fire extinguishers is monoammonium phosphate, which is very sticky and difficult to clean. In addition, in the presence of minute amounts of moisture, monoammonium phosphate can become highly corrosive and corrodes most metals.

Any equipment in a room in which a chemical fire extinguisher has been discharged is subject to premature failure and unreliable operation. The equipment is considered to be irreparably damaged.

NOTE: To keep warranties effective, do not use a dry chemical fire extinguisher to control a fire at or near a Juniper Networks device. If a dry chemical fire extinguisher is used, the unit is no longer eligible for coverage under a service agreement.

We recommend that you dispose of any irreparably damaged equipment in an environmentally responsible manner.

Installation Instructions Warning



WARNING: Read the installation instructions before you connect the device to a power source.

Waarschuwing Raadpleeg de installatie-aanwijzingen voordat u het systeem met de voeding verbindt.

Varoitus Lue asennusohjeet ennen järjestelmän yhdistämistä virtälähteeseen.

Avertissement Avant de brancher le système sur la source d'alimentation, consulter les directives d'installation.

Warnung Lesen Sie die Installationsanweisungen, bevor Sie das System an die Stromquelle anschließen.

Avvertenza Consultare le istruzioni di installazione prima di collegare il sistema all'alimentatore.

Advarsel Les installasjonsinstruksjonene før systemet kobles til strømkilden.

Aviso Leia as instruções de instalação antes de ligar o sistema à sua fonte de energia.

¡Atención! Ver las instrucciones de instalación antes de conectar el sistema a la red de alimentación.

Varning! Läs installationsanvisningarna innan du kopplar systemet till dess strömförsörjningsenhet.

Chassis and Component Lifting Guidelines

- Before moving the device to a site, ensure that the site meets the power, environmental, and clearance requirements.
- Before lifting or moving the device, disconnect all external cables and wires.
- As when lifting any heavy object, ensure that most of the weight is borne by your legs rather than your back. Keep your knees bent and your back relatively straight. Do not twist your body as you lift. Balance the load evenly and be sure that your footing is firm.
- Use the following lifting guidelines to lift devices and components:

- Up to 39.7 lbs (18 kg): One person.
- 39.7 lbs (18 kg) to 70.5 lbs (32 kg): Two or more people.
- 70.5 lbs (32 kg) to 121.2 lbs (55 kg): Three or more people.
- Above 121.2 lbs (55 kg): Material handling systems (such as levers, slings, lifts and so on) must be used. When this is not practical, specially trained persons or systems must be used (riggers or movers).

Restricted Access Warning



WARNING: This unit is intended for installation in restricted access areas. A restricted access area is an area to which access can be gained only by service personnel through the use of a special tool, lock and key, or other means of security, and which is controlled by the authority responsible for the location.

Waarschuwing Dit toestel is bedoeld voor installatie op plaatsen met beperkte toegang. Een plaats met beperkte toegang is een plaats waar toegang slechts door servicepersoneel verkregen kan worden door middel van een speciaal instrument, een slot en sleutel, of een ander veiligheidsmiddel, en welke beheerd wordt door de overheidsinstantie die verantwoordelijk is voor de locatie.

Varoitus Tämä laite on tarkoitettu asennettavaksi paikkaan, johon pääsy on rajoitettua. Paikka, johon pääsy on rajoitettua, tarkoittaa paikkaa, johon vain huoltohenkilöstö pääsee jonkin erikoistyökalun, lukkoon sopivan avaimen tai jonkin muun turvalaitteen avulla ja joka on paikasta vastuussa olevien toimivaltaisten henkilöiden valvoma.

Avertissement Cet appareil est à installer dans des zones d'accès réservé. Ces dernières sont des zones auxquelles seul le personnel de service peut accéder en utilisant un outil spécial, un mécanisme de verrouillage et une clé, ou tout autre moyen de sécurité. L'accès aux zones de sécurité est sous le contrôle de l'autorité responsable de l'emplacement.

Warnung Diese Einheit ist zur Installation in Bereichen mit beschränktem Zutritt vorgesehen. Ein Bereich mit beschränktem Zutritt ist ein Bereich, zu dem nur Wartungspersonal mit einem Spezialwerkzeugs, Schloß und Schlüssel oder anderer Sicherheitsvorkehrungen Zugang hat, und der von dem für die Anlage zuständigen Gremium kontrolliert wird.

Avvertenza Questa unità deve essere installata in un'area ad accesso limitato. Un'area ad accesso limitato è un'area accessibile solo a personale di assistenza tramite un'attrezzo speciale, lucchetto, o altri dispositivi di sicurezza, ed è controllata dall'autorità responsabile della zona.

Advarsel Denne enheten er laget for installasjon i områder med begrenset adgang. Et område med begrenset adgang gir kun adgang til servicepersonale som bruker et spesielt verktøy, lås og nøkkel, eller en annen sikkerhetsanordning, og det kontrolleres av den autoriteten som er ansvarlig for området.

Aviso Esta unidade foi concebida para instalação em áreas de acesso restrito. Uma área de acesso restrito é uma área à qual apenas tem acesso o pessoal de serviço autorizado, que possui uma ferramenta, chave e fechadura especial, ou qualquer outra forma de segurança. Esta área é controlada pela autoridade responsável pelo local.

¡Atención! Esta unidad ha sido diseñada para instalarse en áreas de acceso restringido. Área de acceso restringido significa un área a la que solamente tiene acceso el personal de servicio mediante la utilización de una herramienta especial, cerradura con llave, o algún otro medio de seguridad, y que está bajo el control de la autoridad responsable del local.

Varning! Denna enhet är avsedd för installation i områden med begränsat tillträde. Ett område med begränsat tillträde får endast tillträdas av servicepersonal med ett speciellt verktyg, lås och nyckel, eller annan säkerhetsanordning, och kontrolleras av den auktoritet som ansvarar för området.

Ramp Warning



WARNING: When installing the device, do not use a ramp inclined at more than 10 degrees.

Waarschuwing Gebruik een oprijplaat niet onder een hoek van meer dan 10 graden.

Varoitus Älä käytä sellaista kaltevaa pintaa, jonka kaltevuus ylittää 10 astetta.

Avertissement Ne pas utiliser une rampe dont l'inclinaison est supérieure à 10 degrés.

Warnung Keine Rampen mit einer Neigung von mehr als 10 Grad verwenden.

Avvertenza Non usare una rampa con pendenza superiore a 10 gradi.

Advarsel Bruk aldri en rampe som heller mer enn 10 grader.

Aviso Não utilize uma rampa com uma inclinação superior a 10 graus.

¡Atención! No usar una rampa inclinada más de 10 grados

Varning! Använd inte ramp med en lutning på mer än 10 grader.

Rack-Mounting and Cabinet-Mounting Warnings

Ensure that the rack or cabinet in which the device is installed is evenly and securely supported. Uneven mechanical loading could lead to a hazardous condition.



WARNING: To prevent bodily injury when mounting or servicing the device in a rack, take the following precautions to ensure that the system remains stable. The following directives help maintain your safety:

- The device must be installed in a rack that is secured to the building structure.
- The device should be mounted at the bottom of the rack if it is the only unit in the rack.
- When mounting the device on a partially filled rack, load the rack from the bottom to the top with the heaviest component at the bottom of the rack.
- If the rack is provided with stabilizing equipment, install the stabilizers before mounting or servicing the device in the rack.

Waarschuwing Om lichamelijk letsel te voorkomen wanneer u dit toestel in een rek monteert of het daar een servicebeurt geeft, moet u speciale voorzorgsmaatregelen nemen om ervoor te zorgen dat het toestel stabiel blijft. De onderstaande richtlijnen worden verstrekt om uw veiligheid te verzekeren:

- De Juniper Networks switch moet in een stellage worden geïnstalleerd die aan een bouwsel is verankerd.
- Dit toestel dient onderaan in het rek gemonteerd te worden als het toestel het enige in het rek is.
- Wanneer u dit toestel in een gedeeltelijk gevuld rek monteert, dient u het rek van onderen naar boven te laden met het zwaarste onderdeel onderaan in het rek.
- Als het rek voorzien is van stabiliseringshulpmiddelen, dient u de stabilisatoren te monteren voordat u het toestel in het rek monteert of het daar een servicebeurt geeft.

Varoitus Kun laite asetetaan telineeseen tai huolletaan sen ollessa telineessä, on noudatettava erityisiä varotoimia järjestelmän vakavuuden säilyttämiseksi, jotta vältetään loukkaantumiselta. Noudata seuraavia turvallisuusohjeita:

- Juniper Networks switch on asennettava telineeseen, joka on kiinnitetty rakennukseen.
- Jos telineessä ei ole muita laitteita, aseta laite telineen alaosaan.
- Jos laite asetetaan osaksi täytettyyn telineeseen, aloita kuormittaminen sen alaosasta kaikkein raskaimmalla esineellä ja siirry sitten sen yläosaan.
- Jos telinettä varten on vakaimet, asenna ne ennen laitteen asettamista telineeseen tai sen huoltamista siinä.

Avertissement Pour éviter toute blessure corporelle pendant les opérations de montage ou de réparation de cette unité en casier, il convient de prendre des précautions spéciales afin de maintenir la stabilité du système. Les directives ci-dessous sont destinées à assurer la protection du personnel:

- Le rack sur lequel est monté le Juniper Networks switch doit être fixé à la structure du bâtiment.
- Si cette unité constitue la seule unité montée en casier, elle doit être placée dans le bas.
- Si cette unité est montée dans un casier partiellement rempli, charger le casier de bas en haut en plaçant l'élément le plus lourd dans le bas.
- Si le casier est équipé de dispositifs stabilisateurs, installer les stabilisateurs avant de monter ou de réparer l'unité en casier.

Warnung Zur Vermeidung von Körperverletzung beim Anbringen oder Warten dieser Einheit in einem Gestell müssen Sie besondere Vorkehrungen treffen, um sicherzustellen, daß das System stabil bleibt. Die folgenden Richtlinien sollen zur Gewährleistung Ihrer Sicherheit dienen:

- Der Juniper Networks switch muß in einem Gestell installiert werden, das in der Gebäudestruktur verankert ist.
- Wenn diese Einheit die einzige im Gestell ist, sollte sie unten im Gestell angebracht werden.
- Bei Anbringung dieser Einheit in einem zum Teil gefüllten Gestell ist das Gestell von unten nach oben zu laden, wobei das schwerste Bauteil unten im Gestell anzubringen ist.
- Wird das Gestell mit Stabilisierungszubehör geliefert, sind zuerst die Stabilisatoren zu installieren, bevor Sie die Einheit im Gestell anbringen oder sie warten.

Avvertenza Per evitare infortuni fisici durante il montaggio o la manutenzione di questa unità in un supporto, occorre osservare speciali precauzioni per garantire che il sistema rimanga stabile. Le seguenti direttive vengono fornite per garantire la sicurezza personale:

- Il Juniper Networks switch deve essere installato in un telaio, il quale deve essere fissato alla struttura dell'edificio.
- Questa unità deve venire montata sul fondo del supporto, se si tratta dell'unica unità da montare nel supporto.
- Quando questa unità viene montata in un supporto parzialmente pieno, caricare il supporto dal basso all'alto, con il componente più pesante sistemato sul fondo del supporto.
- Se il supporto è dotato di dispositivi stabilizzanti, installare tali dispositivi prima di montare o di procedere alla manutenzione dell'unità nel supporto.

Advarsel Unngå fysiske skader under montering eller reparasjonsarbeid på denne enheten når den befinner seg i et kabinett. Vær nøye med at systemet er stabilt. Følgende retningslinjer er gitt for å verne om sikkerheten:

- Juniper Networks switch må installeres i et stativ som er forankret til bygningsstrukturen.
- Denne enheten bør monteres nederst i kabinettet hvis dette er den eneste enheten i kabinettet.
- Ved montering av denne enheten i et kabinett som er delvis fylt, skal kabinettet lastes fra bunnen og opp med den tyngste komponenten nederst i kabinettet.
- Hvis kabinettet er utstyrt med stabiliseringsutstyr, skal stabilisatorene installeres før montering eller utføring av reparasjonsarbeid på enheten i kabinettet.

Aviso Para se prevenir contra danos corporais ao montar ou reparar esta unidade numa estante, deverá tomar precauções especiais para se certificar de que o sistema possui um suporte estável. As seguintes directrizes ajudá-lo-ão a efectuar o seu trabalho com segurança:

- O Juniper Networks switch deverá ser instalado numa prateleira fixa à estrutura do edifício.
- Esta unidade deverá ser montada na parte inferior da estante, caso seja esta a única unidade a ser montada.
- Ao montar esta unidade numa estante parcialmente ocupada, coloque os itens mais pesados na parte inferior da estante, arrumando-os de baixo para cima.
- Se a estante possuir um dispositivo de estabilização, instale-o antes de montar ou reparar a unidade.

¡Atención! Para evitar lesiones durante el montaje de este equipo sobre un bastidor, oerriormente durante su mantenimiento, se debe poner mucho cuidado en que el sistema quede bien estable. Para garantizar su seguridad, proceda según las siguientes instrucciones:

- El Juniper Networks switch debe instalarse en un bastidor fijado a la estructura del edificio.
- Colocar el equipo en la parte inferior del bastidor, cuando sea la única unidad en el mismo.
- Cuando este equipo se vaya a instalar en un bastidor parcialmente ocupado, comenzar la instalación desde la parte inferior hacia la superior colocando el equipo más pesado en la parte inferior.
- Si el bastidor dispone de dispositivos estabilizadores, instalar éstos antes de montar o proceder al mantenimiento del equipo instalado en el bastidor.

Warning! För att undvika kroppsskada när du installerar eller utför underhållsarbete på denna enhet på en ställning måste du vidta särskilda försiktighetsåtgärder för att försäkra dig om att systemet står stadigt. Följande riktlinjer ges för att trygga din säkerhet:

- Juniper Networks switch måste installeras i en ställning som är förankrad i byggnadens struktur.
- Om denna enhet är den enda enheten på ställningen skall den installeras längst ned på ställningen.
- Om denna enhet installeras på en delvis fylld ställning skall ställningen fyllas nedifrån och upp, med de tyngsta enheterna längst ned på ställningen.
- Om ställningen är försedd med stabiliseringsdon skall dessa monteras fast innan enheten installeras eller underhålls på ställningen.

Grounded Equipment Warning



WARNING: This device must be properly grounded at all times. Follow the instructions in this guide to properly ground the device to earth.

Waarschuwing Dit apparaat moet altijd goed geaard zijn. Volg de instructies in deze gids om het apparaat goed te aarden.

Varoitus Laitteen on oltava pysyvästi maadoitettu. Maadoita laite asianmukaisesti noudattamalla tämän oppaan ohjeita.

Avertissement L'appareil doit être correctement mis à la terre à tout moment. Suivez les instructions de ce guide pour correctement mettre l'appareil à la terre.

Warnung Das Gerät muss immer ordnungsgemäß geerdet sein. Befolgen Sie die Anweisungen in dieser Anleitung, um das Gerät ordnungsgemäß zu erden.

Avvertenza Questo dispositivo deve sempre disporre di una connessione a massa. Seguire le istruzioni indicate in questa guida per connettere correttamente il dispositivo a massa.

Advarsel Denne enheten på jordes skikkelig hele tiden. Følg instruksjonene i denne veiledningen for å jorde enheten.

Aviso Este equipamento deverá estar ligado à terra. Siga las instrucciones en esta guía para conectar correctamente este dispositivo a tierra.

¡Atención! Este dispositivo debe estar correctamente conectado a tierra en todo momento. Siga las instrucciones en esta guía para conectar correctamente este dispositivo a tierra.

Warning! Den här enheten måste vara ordentligt jordad. Följ instruktionerna i den här guiden för att jorda enheten ordentligt.

Radiation from Open Port Apertures Warning



WARNING: Because invisible radiation might be emitted from the aperture of the port when no fiber cable is connected, avoid exposure to radiation and do not stare into open apertures.

Waarschuwing Aangezien onzichtbare straling vanuit de opening van de poort kan komen als er geen fiberkabel aangesloten is, dient blootstelling aan straling en het kijken in open openingen vermeden te worden.

Varoitus Koska portin aukosta voi emittoitua näkymätöntä säteilyä, kun kuitukaapelia ei ole kytkettynä, vältä säteilylle altistumista äläkä katso avoimiin aukkoihin.

Avertissement Des radiations invisibles à l'il nu pouvant traverser l'ouverture du port lorsqu'aucun câble en fibre optique n'y est connecté, il est recommandé de ne pas regarder fixement l'intérieur de ces ouvertures.

Warnung Aus der Port-Öffnung können unsichtbare Strahlen emittieren, wenn kein Glasfaserkabel angeschlossen ist. Vermeiden Sie es, sich den Strahlungen auszusetzen, und starren Sie nicht in die Öffnungen!

Avvertenza Quando i cavi in fibra non sono inseriti, radiazioni invisibili possono essere emesse attraverso l'apertura della porta. Evitate di esporvi alle radiazioni e non guardate direttamente nelle aperture.

Advarsel Unngå utsettelse for stråling, og stirr ikke inn i åpninger som er åpne, fordi usynlig stråling kan emitteres fra portens åpning når det ikke er tilkoblet en fiberkabel.

Aviso Dada a possibilidade de emissão de radiação invisível através do orifício da via de acesso, quando esta não tiver nenhum cabo de fibra conectado, deverá evitar a exposição à radiação e não deverá olhar fixamente para orifícios que se encontrarem a descoberto.

¡Atención! Debido a que la apertura del puerto puede emitir radiación invisible cuando no existe un cable de fibra conectado, evite mirar directamente a las aperturas para no exponerse a la radiación.

Warning! Osynlig stråling kan avges från en portöppning utan ansluten fiberkabel och du bör därför undvika att bli utsatt för stråling genom att inte stirra in i oskyddade öppningar.

Laser and LED Safety Guidelines and Warnings

IN THIS SECTION

- [General Laser Safety Guidelines | 249](#)
- [Class 1 Laser Product Warning | 250](#)
- [Class 1 LED Product Warning | 251](#)
- [Laser Beam Warning | 252](#)

Juniper Networks devices are equipped with laser transmitters, which are considered a Class 1 Laser Product by the U.S. Food and Drug Administration and are evaluated as a Class 1 Laser Product per EN 60825-1 requirements.

Observe the following guidelines and warnings:

General Laser Safety Guidelines

When working around ports that support optical transceivers, observe the following safety guidelines to prevent eye injury:

- Do not look into unterminated ports or at fibers that connect to unknown sources.
- Do not examine unterminated optical ports with optical instruments.
- Avoid direct exposure to the beam.



WARNING: Unterminated optical connectors can emit invisible laser radiation. The lens in the human eye focuses all the laser power on the retina, so focusing the eye directly on a laser source—even a low-power laser—could permanently damage the eye.

Avertissement Les connecteurs à fibre optique sans terminaison peuvent émettre un rayonnement laser invisible. Le cristallin de l'œil humain faisant converger toute la puissance du laser sur la rétine, toute focalisation directe de l'œil sur une source laser, —même de faible puissance—, peut entraîner des lésions oculaires irréversibles.

Class 1 Laser Product Warning



WARNING: Class 1 laser product.

Waarschuwing Klasse-1 laser produkt.

Varoitus Luokan 1 lasertuote.

Avertissement Produit laser de classe I.

Warnung Laserprodukt der Klasse 1.

Avvertenza Prodotto laser di Classe 1.

Advarsel Laserprodukt av klasse 1.

Aviso Produto laser de classe 1.

¡Atención! Producto láser Clase I.

Varning! Laserprodukt av klass 1.

Class 1 LED Product Warning



WARNING: Class 1 LED product.

Waarschuwing Klasse 1 LED-product.

Varoitus Luokan 1 valodiodituote.

Avertissement Alarme de produit LED Class I.

Warnung Class 1 LED-Produktwarnung.

Avvertenza Avvertenza prodotto LED di Classe 1.

Advarsel LED-produkt i klasse 1.

Aviso Produto de classe 1 com LED.

¡Atención! Aviso sobre producto LED de Clase 1.

Varning! Lysdiodprodukt av klass 1.

Laser Beam Warning



WARNING: Do not stare into the laser beam or view it directly with optical instruments.

Waarschuwing Niet in de straal staren of hem rechtstreeks bekijken met optische instrumenten.

Varoitus Älä katso säteeseen äläkä tarkastele sitä suoraan optisen laitteen avulla.

Avertissement Ne pas fixer le faisceau des yeux, ni l'observer directement à l'aide d'instruments optiques.

Warnung Nicht direkt in den Strahl blicken und ihn nicht direkt mit optischen Geräten prüfen.

Avvertenza Non fissare il raggio con gli occhi né usare strumenti ottici per osservarlo direttamente.

Advarsel Stirr eller se ikke direkte p strlen med optiske instrumenter.

Aviso Não olhe fixamente para o raio, nem olhe para ele directamente com instrumentos ópticos.

¡Atención! No mirar fijamente el haz ni observarlo directamente con instrumentos ópticos.

Warning! Rikta inte blicken in mot strålen och titta inte direkt på den genom optiska instrument.

Maintenance and Operational Safety Guidelines and Warnings

IN THIS SECTION

- [Battery Handling Warning | 254](#)
- [Jewelry Removal Warning | 255](#)
- [Lightning Activity Warning | 257](#)

- Operating Temperature Warning | 258
- Product Disposal Warning | 260

While performing the maintenance activities for devices, observe the following guidelines and warnings:

Battery Handling Warning



WARNING: Replacing a battery incorrectly might result in an explosion. Replace a battery only with the same or equivalent type recommended by the manufacturer. Dispose of used batteries according to the manufacturer's instructions.

Waarschuwing Er is ontplofingsgevaar als de batterij verkeerd vervangen wordt. Vervang de batterij slechts met hetzelfde of een equivalent type dat door de fabrikant aanbevolen is. Gebruikte batterijen dienen overeenkomstig fabrieksvoorschriften weggeworpen te worden.

Varoitus Räjähdyksen vaara, jos akku on vaihdettu väärään akkuun. Käytä vaihtamiseen ainoastaan saman- tai vastaaventyyppistä akkua, joka on valmistajan suosittelema. Hävitä käytetyt akut valmistajan ohjeiden mukaan.

Avertissement Danger d'explosion si la pile n'est pas remplacée correctement. Ne la remplacer que par une pile de type semblable ou équivalent, recommandée par le fabricant. Jeter les piles usagées conformément aux instructions du fabricant.

Warnung Bei Einsetzen einer falschen Batterie besteht Explosionsgefahr. Ersetzen Sie die Batterie nur durch den gleichen oder vom Hersteller empfohlenen Batterietyp. Entsorgen Sie die benutzten Batterien nach den Anweisungen des Herstellers.

Advarsel Det kan være fare for eksplosjon hvis batteriet skiftes på feil måte. Skift kun med samme eller tilsvarende type som er anbefalt av produsenten. Kasser brukte batterier i henhold til produsentens instruksjoner.

Avvertenza Pericolo di esplosione se la batteria non è installata correttamente. Sostituire solo con una di tipo uguale o equivalente, consigliata dal produttore. Eliminare le batterie usate secondo le istruzioni del produttore.

Aviso Existe perigo de explosão se a bateria for substituída incorrectamente. Substitua a bateria por uma bateria igual ou de um tipo equivalente recomendado pelo fabricante. Destrua as baterias usadas conforme as instruções do fabricante.

¡Atención! Existe peligro de explosión si la batería se reemplaza de manera incorrecta. Reemplazar la batería EXclusivamente con el mismo tipo o el equivalente recomendado por el fabricante. Desechar las baterías gastadas según las instrucciones del fabricante.

Warning! Explosionsfara vid felaktigt batteribyte. Ersätt endast batteriet med samma batterityp som rekommenderas av tillverkaren eller motsvarande. Följ tillverkarens anvisningar vid kassering av använda batterier.

Jewelry Removal Warning



WARNING: Before working on equipment that is connected to power lines, remove jewelry, including rings, necklaces, and watches. Metal objects heat up when connected to power and ground and can cause serious burns or can be welded to the terminals.

Waarschuwing Alvorens aan apparatuur te werken die met elektrische leidingen is verbonden, sieraden (inclusief ringen, kettingen en horloges) verwijderen. Metalen voorwerpen worden warm wanneer ze met stroom en aarde zijn verbonden, en kunnen ernstige brandwonden veroorzaken of het metalen voorwerp aan de aansluitklemmen lassen.

Varoitus Ennen kuin työskentelet voimavirtajohtoihin kytkettyjen laitteiden parissa, ota pois kaikki korut (sormukset, kaulakorut ja kellot mukaan lukien). Metalliesineet kuumentuvat, kun ne ovat yhteydessä sähkövirran ja maan kanssa, ja ne voivat aiheuttaa vakavia palovammoja tai hitsata metalliesineet kiinni liitännänpoihin.

Avertissement Avant d'accéder à cet équipement connecté aux lignes électriques, ôter tout bijou (anneaux, colliers et montres compris). Lorsqu'ils sont branchés à l'alimentation et reliés à la terre, les objets métalliques chauffent, ce qui peut provoquer des blessures graves ou souder l'objet métallique aux bornes.

Warnung Vor der Arbeit an Geräten, die an das Netz angeschlossen sind, jeglichen Schmuck (einschließlich Ringe, Ketten und Uhren) abnehmen. Metallgegenstände erhitzen sich, wenn sie an das Netz und die Erde angeschlossen werden, und können schwere Verbrennungen verursachen oder an die Anschlußklemmen angeschweißt werden.

Avvertenza Prima di intervenire su apparecchiature collegate alle linee di alimentazione, togliersi qualsiasi monile (inclusi anelli, collane, braccialetti ed orologi). Gli oggetti metallici si riscaldano quando sono collegati tra punti di alimentazione e massa: possono causare ustioni gravi oppure il metallo può saldarsi ai terminali.

Advarsel Fjern alle smykker (inkludert ringer, halskjeder og klokker) før du skal arbeide på utstyr som er koblet til kraftledninger. Metallgjenstander som er koblet til kraftledninger og jord blir svært varme og kan forårsake alvorlige brannskader eller smelte fast til polene.

Aviso Antes de trabalhar em equipamento que esteja ligado a linhas de corrente, retire todas as jóias que estiver a usar (incluindo anéis, fios e relógios). Os objectos metálicos aquecerão em contacto com a corrente e em contacto com a ligação à terra, podendo causar queimaduras graves ou ficarem soldados aos terminais.

¡Atención! Antes de operar sobre equipos conectados a líneas de alimentación, quitarse las joyas (incluidos anillos, collares y relojes). Los objetos de metal se calientan cuando

se conectan a la alimentación y a tierra, lo que puede ocasionar quemaduras graves o que los objetos metálicos queden soldados a los bornes.

Warning! Tag av alla smycken (inklusive ringar, halsband och armbandsur) innan du arbetar på utrustning som är kopplad till kraftledning. Metallobjekt hettas upp när de kopplas ihop med ström och jord och kan förorsaka allvarliga brännskador; metallobjekt kan också sammansvetsas med kontakterna.

Lightning Activity Warning



WARNING: Do not work on the system or connect or disconnect cables during periods of lightning activity.

Waarschuwing Tijdens onweer dat gepaard gaat met bliksem, dient u niet aan het systeem te werken of kabels aan te sluiten of te ontkoppelen.

Varoitus Älä työskentele järjestelmän parissa äläkä yhdistä tai irrota kaapeleita ukkosilmalla.

Avertissement Ne pas travailler sur le système ni brancher ou débrancher les câbles pendant un orage.

Warnung Arbeiten Sie nicht am System und schließen Sie keine Kabel an bzw. trennen Sie keine ab, wenn es gewittert.

Avvertenza Non lavorare sul sistema o collegare oppure scollegare i cavi durante un temporale con fulmini.

Advarsel Utfør aldri arbeid på systemet, eller koble kabler til eller fra systemet når det tordner eller lyner.

Aviso Não trabalhe no sistema ou ligue e desligue cabos durante períodos de mau tempo (trovoada).

¡Atención! No operar el sistema ni conectar o desconectar cables durante el transcurso de descargas eléctricas en la atmósfera.

Warning! Vid åska skall du aldrig utföra arbete på systemet eller ansluta eller koppla loss kablar.

Operating Temperature Warning



WARNING: To prevent the device from overheating, do not operate it in an area that exceeds the maximum recommended ambient temperature. To prevent airflow restriction, allow at least 6 in. (15.2 cm) of clearance around the ventilation openings.

Waarschuwing Om te voorkomen dat welke switch van de Juniper Networks router dan ook oververhit raakt, dient u deze niet te bedienen op een plaats waar de maximale aanbevolen omgevingstemperatuur van 40° C wordt overschreden. Om te voorkomen dat de luchtstroom wordt beperkt, dient er minstens 15,2 cm speling rond de ventilatie-openingen te zijn.

Varoitus Ettei Juniper Networks switch-sarjan reititin ylikuumentuusi, sitä ei saa käyttää tilassa, jonka lämpötila ylittää korkeimman suositellun ympäristölämpötilan 40° C. Ettei ilmanvaihto estyisi, tuuletusaukkojen ympärille on jätettävä ainakin 15,2 cm tilaa.

Avertissement Pour éviter toute surchauffe des routeurs de la gamme Juniper Networks switch, ne l'utilisez pas dans une zone où la température ambiante est supérieure à 40° C. Pour permettre un flot d'air constant, dégagez un espace d'au moins 15,2 cm autour des ouvertures de ventilations.

Warnung Um einen Router der switch vor Überhitzung zu schützen, darf dieser nicht in einer Gegend betrieben werden, in der die Umgebungstemperatur das empfohlene Maximum von 40° C überschreitet. Um Lüftungsverschluß zu verhindern, achten Sie darauf, daß mindestens 15,2 cm lichter Raum um die Lüftungsöffnungen herum frei bleibt.

Avvertenza Per evitare il surriscaldamento dei switch, non adoperateli in un locale che ecceda la temperatura ambientale massima di 40° C. Per evitare che la circolazione dell'aria sia impedita, lasciate uno spazio di almeno 15.2 cm di fronte alle aperture delle ventole.

Advarsel Unngå overoppheting av eventuelle rutere i Juniper Networks switch Disse skal ikke brukes på steder der den anbefalte maksimale omgivelsestemperaturen overstiger 40° C (104° F). Sørg for at klaringen rundt lufteåpningene er minst 15,2 cm (6 tommer) for å forhindre nedsatt luftsirkulasjon.

Aviso Para evitar o sobreaquecimento do encaminhador Juniper Networks switch, não utilize este equipamento numa área que exceda a temperatura máxima recomendada de 40° C. Para evitar a restrição à circulação de ar, deixe pelo menos um espaço de 15,2 cm à volta das aberturas de ventilação.

¡Atención! Para impedir que un encaminhador de la serie Juniper Networks switch se recaliente, no lo haga funcionar en un área en la que se supere la temperatura ambiente máxima recomendada de 40° C. Para impedir la restricción de la entrada de aire, deje un espacio mínimo de 15,2 cm alrededor de las aberturas para ventilación.

Warning! Förhindra att en Juniper Networks switch överhettas genom att inte använda den i ett område där den maximalt rekommenderade omgivningstemperaturen på 40° C överskrids. Förhindra att luftcirkulationen inskränks genom att se till att det finns fritt utrymme på minst 15,2 cm omkring ventilationsöppningarna.

Product Disposal Warning



WARNING: Disposal of this device must be handled according to all national laws and regulations.

Waarschuwing Dit produkt dient volgens alle landelijke wetten en voorschriften te worden afgedankt.

Varoitus Tämän tuotteen lopullisesta hävittämisestä tulee huolehtia kaikkia valtakunnallisia lakeja ja säännöksiä noudattaen.

Avertissement La mise au rebut définitive de ce produit doit être effectuée conformément à toutes les lois et réglementations en vigueur.

Warnung Dieses Produkt muß den geltenden Gesetzen und Vorschriften entsprechend entsorgt werden.

Avvertenza L'eliminazione finale di questo prodotto deve essere eseguita osservando le normative italiane vigenti in materia

Advarsel Endelig disponering av dette produktet må skje i henhold til nasjonale lover og forskrifter.

Aviso A descartagem final deste produto deverá ser efectuada de acordo com os regulamentos e a legislação nacional.

¡Atención! El desecho final de este producto debe realizarse según todas las leyes y regulaciones nacionales

Warning! Slutlig kassering av denna produkt bör skötas i enlighet med landets alla lagar och föreskrifter.

General Electrical Safety Guidelines and Warnings



WARNING: Certain ports on the device are designed for use as intrabuilding (within-the-building) interfaces only (Type 2 or Type 4 ports as described in GR-1089-CORE) and require isolation from the exposed outside plant (OSP) cabling. To comply with NEBS requirements and protect against lightning surges and commercial power disturbances, the intrabuilding ports *must not* be metallicity connected to interfaces that connect to the OSP or its wiring. The intrabuilding ports on the device are suitable for connection to intrabuilding or unexposed wiring or cabling only. The addition of primary protectors is not sufficient protection for connecting these interfaces metallicity to OSP wiring.

Avertissement Certains ports de l'appareil sont destinés à un usage en intérieur uniquement (ports Type 2 ou Type 4 tels que décrits dans le document GR-1089-CORE) et doivent être isolés du câblage de l'installation extérieure exposée. Pour respecter les exigences NEBS et assurer une protection contre la foudre et les perturbations de tension secteur, les ports pour intérieur *ne doivent pas* être raccordés physiquement aux interfaces prévues pour la connexion à l'installation extérieure ou à son câblage. Les ports pour intérieur de l'appareil sont réservés au raccordement de câbles pour intérieur ou non exposés uniquement. L'ajout de protections ne constitue pas une précaution suffisante pour raccorder physiquement ces interfaces au câblage de l'installation extérieure.



CAUTION: Before removing or installing components of a device, connect an electrostatic discharge (ESD) grounding strap to an ESD point and wrap and fasten the other end of the strap around your bare wrist. Failure to use an ESD grounding strap could result in damage to the device.

Attention Avant de retirer ou d'installer des composants d'un appareil, raccordez un bracelet antistatique à un point de décharge électrostatique et fixez le bracelet à votre poignet nu. L'absence de port d'un bracelet antistatique pourrait provoquer des dégâts sur l'appareil.

- Install the device in compliance with the following local, national, and international electrical codes:
 - United States—National Fire Protection Association (NFPA 70), United States National Electrical Code.
 - Other countries—International Electrotechnical Commission (IEC) 60364, Part 1 through Part 7.
 - Evaluated to the TN power system.

- Canada—Canadian Electrical Code, Part 1, CSA C22.1.
- Suitable for installation in Information Technology Rooms in accordance with Article 645 of the National Electrical Code and NFPA 75.

Peut être installé dans des salles de matériel de traitement de l'information conformément à l'article 645 du National Electrical Code et à la NFPA 75.

- Locate the emergency power-off switch for the room in which you are working so that if an electrical accident occurs, you can quickly turn off the power.
- Make sure that grounding surfaces are cleaned and brought to a bright finish before grounding connections are made.
- Do not work alone if potentially hazardous conditions exist anywhere in your workspace.
- Never assume that power is disconnected from a circuit. Always check the circuit before starting to work.
- Carefully look for possible hazards in your work area, such as moist floors, ungrounded power extension cords, and missing safety grounds.
- Operate the device within marked electrical ratings and product usage instructions.
- To ensure that the device and peripheral equipment function safely and correctly, use the cables and connectors specified for the attached peripheral equipment, and make certain they are in good condition.

You can remove and replace many device components without powering off or disconnecting power to the device, as detailed elsewhere in the hardware documentation for this device. Never install equipment that appears to be damaged.

Action to Take After an Electrical Accident

If an electrical accident results in an injury, take the following actions in this order:

1. Use caution. Be aware of potentially hazardous conditions that could cause further injury.
2. Disconnect power from the device.
3. If possible, send another person to get medical aid. Otherwise, assess the condition of the victim, then call for help.

Prevention of Electrostatic Discharge Damage

Device components that are shipped in antistatic bags are sensitive to damage from static electricity. Some components can be impaired by voltages as low as 30 V. You can easily generate potentially damaging static voltages whenever you handle plastic or foam packing material or if you move components across plastic or carpets. Observe the following guidelines to minimize the potential for electrostatic discharge (ESD) damage, which can cause intermittent or complete component failures:

- Always use an ESD wrist strap when you are handling components that are subject to ESD damage, and make sure that it is in direct contact with your skin.

If a grounding strap is not available, hold the component in its antistatic bag (see [Figure 62 on page 264](#)) in one hand and touch the exposed, bare metal of the device with the other hand immediately before inserting the component into the device.



WARNING: For safety, periodically check the resistance value of the ESD grounding strap. The measurement must be in the range 1 through 10 Mohms.

Avertissement Par mesure de sécurité, vérifiez régulièrement la résistance du bracelet antistatique. Cette valeur doit être comprise entre 1 et 10 mégohms (Mohms).

- When handling any component that is subject to ESD damage and that is removed from the device, make sure the equipment end of your ESD wrist strap is attached to the ESD point on the chassis.

If no grounding strap is available, touch the exposed, bare metal of the device to ground yourself before handling the component.

- Avoid contact between the component that is subject to ESD damage and your clothing. ESD voltages emitted from clothing can damage components.
- When removing or installing a component that is subject to ESD damage, always place it component-side up on an antistatic surface, in an antistatic card rack, or in an antistatic bag (see [Figure 62 on page 264](#)). If you are returning a component, place it in an antistatic bag before packing it.

Figure 62: Placing a Component into an Antistatic Bag

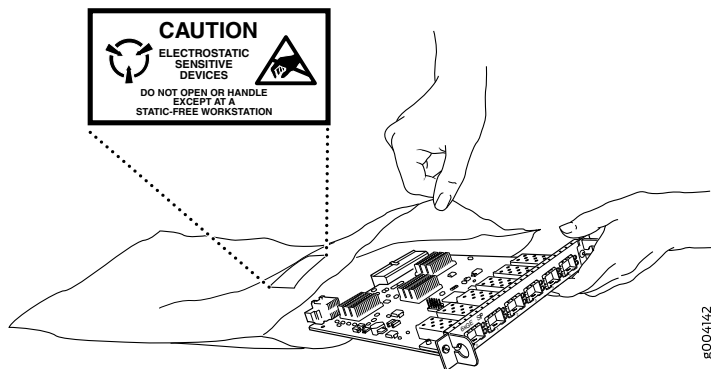

CAUTION: ANSI/TIA/EIA-568 cables such as Category 5e and Category 6 can get electrostatically charged. To dissipate this charge, always ground the cables to a suitable and safe earth ground before connecting them to the system.

Attention Les câbles ANSI/TIA/EIA-568, par exemple Cat 5e et Cat 6, peuvent emmagasiner des charges électrostatiques. Pour évacuer ces charges, reliez toujours les câbles à une prise de terre adaptée avant de les raccorder au système.

AC Power Electrical Safety Guidelines

The following electrical safety guidelines apply to AC-powered devices:

- Note the following warnings printed on the device:

“CAUTION: THIS UNIT HAS MORE THAN ONE POWER SUPPLY CORD. DISCONNECT ALL POWER SUPPLY CORDS BEFORE SERVICING TO AVOID ELECTRIC SHOCK.”

“ATTENTION: CET APPAREIL COMPORTE PLUS D'UN CORDON D'ALIMENTATION. AFIN DE PRÉVENIR LES CHOCS ÉLECTRIQUES, DÉBRANCHER TOUT CORDON D'ALIMENTATION AVANT DE FAIRE LE DÉPANNAGE.”

- AC-powered devices are shipped with a three-wire electrical cord with a grounding-type plug that fits only a grounding-type power outlet. Do not circumvent this safety feature. Equipment grounding must comply with local and national electrical codes.
- You must provide an external certified circuit breaker (2-pole circuit breaker or 4-pole circuit breaker based on your device) rated minimum 20 A in the building installation.

- The power cord serves as the main disconnecting device for the AC-powered device. The socket outlet must be near the AC-powered device and be easily accessible.
- For devices that have more than one power supply connection, you must ensure that all power connections are fully disconnected so that power to the device is completely removed to prevent electric shock. To disconnect power, unplug all power cords (one for each power supply).

Power Cable Warning (Japanese)

WARNING: The attached power cable is only for this product. Do not use the cable for another product.

注意

附属の電源コードセットはこの製品専用です。
他の電気機器には使用しないでください。

9017253

AC Power Disconnection Warning



WARNING: Before working on the device or near power supplies, unplug all the power cords from an AC-powered device.

Waarschuwing Voordat u aan een frame of in de nabijheid van voedingen werkt, dient u bij wisselstroom toestellen de stekker van het netsnoer uit het stopcontact te halen.

Varoitus Kytke irti vaihtovirtalaitteiden virtajohto, ennen kuin teet mitään asennuspohjalle tai työskentelet virtalähteiden läheisyydessä.

Avertissement Avant de travailler sur un châssis ou à proximité d'une alimentation électrique, débrancher le cordon d'alimentation des unités en courant alternatif.

Warnung Bevor Sie an einem Chassis oder in der Nähe von Netzgeräten arbeiten, ziehen Sie bei Wechselstromeinheiten das Netzkabel ab bzw.

Avvertenza Prima di lavorare su un telaio o intorno ad alimentatori, scollegare il cavo di alimentazione sulle unità CA.

Advarsel Før det utføres arbeid på kabinettet eller det arbeides i nærheten av strømforsyningsenheter, skal strømledningen trekkes ut på vekselstrømsenheter.

Aviso Antes de trabalhar num chassis, ou antes de trabalhar perto de unidades de fornecimento de energia, desligue o cabo de alimentação nas unidades de corrente alternada.

¡Atención! Antes de manipular el chasis de un equipo o trabajar cerca de una fuente de alimentación, desenchufar el cable de alimentación en los equipos de corriente alterna (CA).

Warning! Innan du arbetar med ett chassi eller nära strömförsörjningsenheter skall du för växelströmsenheter dra ur nätsladden.

DC Power Electrical Safety Guidelines

- A DC-powered device is equipped with a DC terminal block that is rated for the power requirements of a maximally configured device.
- For permanently connected equipment, a readily accessible disconnect device shall be incorporated external to the equipment.
- For pluggable equipment, the socket-outlet shall be installed near the equipment and shall be easily accessible.
- Be sure to connect the ground wire or conduit to a solid central office earth ground.
- A closed loop ring is recommended for terminating the ground conductor at the ground stud.
- Run two wires from the circuit breaker box to a source of 48 VDC.
- A DC-powered device that is equipped with a DC terminal block is intended only for installation in a restricted-access location. In the United States, a restricted-access area is one in accordance with Articles 110-16, 110-17, and 110-18 of the National Electrical Code ANSI/NFPA 70.

NOTE: Primary overcurrent protection is provided by the building circuit breaker. This breaker must protect against excess currents, short circuits, and earth grounding faults in accordance with NEC ANSI/NFPA 70.

- Ensure that the polarity of the DC input wiring is correct. Under certain conditions, connections with reversed polarity might trip the primary circuit breaker or damage the equipment.
- The marked input voltage of -48 VDC for a DC-powered device is the nominal voltage associated with the battery circuit, and any higher voltages are only to be associated with float voltages for the charging function.
- Because the device is a positive ground system, you must connect the positive lead to the terminal labeled **RTN**, the negative lead to the terminal labeled -48 VDC, and the earth ground to the device grounding points.

DC Power Disconnection Warning



WARNING: Before performing any of the DC power procedures, ensure that power is removed from the DC circuit. To ensure that all power is off, locate the circuit breaker on the panel board that services the DC circuit, switch the circuit breaker to the OFF position, and tape the device handle of the circuit breaker in the OFF position.

Waarschuwing Voordat u een van de onderstaande procedures uitvoert, dient u te controleren of de stroom naar het gelijkstroom circuit uitgeschakeld is. Om u ervan te verzekeren dat alle stroom UIT is geschakeld, kiest u op het schakelbord de stroomverbreker die het gelijkstroom circuit bedient, draait de stroomverbreker naar de UIT positie en plakt de schakelaarhendel van de stroomverbreker met plakband in de UIT positie vast.

Varoitus Varmista, että tasavirtapiirissä ei ole virtaa ennen seuraavien toimenpiteiden suorittamista. Varmistaaksesi, että virta on KATKAISTU täysin, paikanna tasavirrasta huolehtivassa kojetaulussa sijaitseva suojakytkin, käännä suojakytkin KATKAISTU-asentoon ja teippaa suojakytkimen varsi niin, että se pysyy KATKAISTU-asennossa.

Avertissement Avant de pratiquer l'une quelconque des procédures ci-dessous, vérifier que le circuit en courant continu n'est plus sous tension. Pour en être sûr, localiser le disjoncteur situé sur le panneau de service du circuit en courant continu, placer le disjoncteur en position fermée (OFF) et, à l'aide d'un ruban adhésif, bloquer la poignée du disjoncteur en position OFF.

Warnung Vor Ausführung der folgenden Vorgänge ist sicherzustellen, daß die Gleichstromschaltung keinen Strom erhält. Um sicherzustellen, daß sämtlicher Strom abgestellt ist, machen Sie auf der Schalttafel den Unterbrecher für die Gleichstromschaltung ausfindig, stellen Sie den Unterbrecher auf AUS, und kleben Sie den Schaltergriff des Unterbrechers mit Klebeband in der AUS-Stellung fest.

Avvertenza Prima di svolgere una qualsiasi delle procedure seguenti, verificare che il circuito CC non sia alimentato. Per verificare che tutta l'alimentazione sia scollegata (OFF), individuare l'interruttore automatico sul quadro strumenti che alimenta il circuito CC, mettere l'interruttore in posizione OFF e fissarlo con nastro adesivo in tale posizione.

Advarsel Før noen av disse prosedyrene utføres, kontroller at strømmen er frakoblet likestrømkretsen. Sørg for at all strøm er slått AV. Dette gjøres ved å lokalisere strømbryteren på brytertavlen som betjener likestrømkretsen, slå strømbryteren AV og teipe bryterhåndtaket på strømbryteren i AV-stilling.

Aviso Antes de executar um dos seguintes procedimentos, certifique-se que desligou a fonte de alimentação de energia do circuito de corrente contínua. Para se assegurar

que toda a corrente foi DESLIGADA, localize o disjuntor no painel que serve o circuito de corrente contínua e coloque-o na posição OFF (Desligado), segurando nessa posição a manivela do interruptor do disjuntor com fita isoladora.

¡Atención! Antes de proceder con los siguientes pasos, comprobar que la alimentación del circuito de corriente continua (CC) esté cortada (OFF). Para asegurarse de que toda la alimentación esté cortada (OFF), localizar el interruptor automático en el panel que alimenta al circuito de corriente continua, cambiar el interruptor automático a la posición de Apagado (OFF), y sujetar con cinta la palanca del interruptor automático en posición de Apagado (OFF).

Warning! Innan du utför någon av följande procedurer måste du kontrollera att strömförsörjningen till likströmskretsen är bruten. Kontrollera att all strömförsörjning är BRUTEN genom att slå AV det överspänningsskydd som skyddar likströmskretsen och tejpa fast överspänningsskyddets omkopplare i FRÅN-läget.

DC Power Grounding Requirements and Warning

An insulated grounding conductor that is identical in size to the grounded and ungrounded branch circuit supply conductors but is identifiable by green and yellow stripes is installed as part of the branch circuit that supplies the device. The grounding conductor is a separately derived system at the supply transformer or motor generator set.



WARNING: When you install the device, the ground connection must always be made first and disconnected last.

Waarschuwing Bij de installatie van het toestel moet de aardverbinding altijd het eerste worden gemaakt en het laatste worden losgemaakt.

Varoitus Laitetta asennettaessa on maahan yhdistäminen aina tehtävä ensiksi ja maadoituksen irti kytkeminen viimeiseksi.

Avertissement Lors de l'installation de l'appareil, la mise à la terre doit toujours être connectée en premier et déconnectée en dernier.

Warnung Der Erdanschluß muß bei der Installation der Einheit immer zuerst hergestellt und zuletzt abgetrennt werden.

Avvertenza In fase di installazione dell'unità, eseguire sempre per primo il collegamento a massa e disconnetterlo per ultimo.

Advarsel Når enheten installeres, må jordledningen alltid tilkobles først og frakobles sist.

Aviso Ao instalar a unidade, a ligação à terra deverá ser sempre a primeira a ser ligada, e a última a ser desligada.

¡Atención! Al instalar el equipo, conectar la tierra la primera y desconectarla la última.

Warning! Vid installation av enheten måste jordledningen alltid anslutas först och kopplas bort sist.

DC Power Wiring Sequence Warning



WARNING: Wire the DC power supply using the appropriate lugs. When connecting power, the proper wiring sequence is ground to ground, +RTN to +RTN, then -48 V to -48 V. When disconnecting power, the proper wiring sequence is -48 V to -48 V, +RTN to +RTN, then ground to ground. Note that the ground wire must always be connected first and disconnected last.

Waarschuwing De juiste bedradingsvolgorde verbonden is aarde naar aarde, +RTN naar +RTN, en -48 V naar -48 V. De juiste bedradingsvolgorde losgemaakt is en -48 naar -48 V, +RTN naar +RTN, aarde naar aarde.

Varoitus Oikea yhdistettävä kytkentäjäjestys on maajohto maajohtoon, +RTN varten +RTN, -48 V varten -48 V. Oikea irrotettava kytkentäjäjestys on -48 V varten -48 V, +RTN varten +RTN, maajohto maajohtoon.

Avertissement Câblez l'alimentation d'alimentation CC En utilisant les crochets appropriés à l'extrémité de câblage. En reliant la puissance, l'ordre approprié de câblage est rectifié pour rectifier, +RTN à +RTN, puis -48 V à -48 V. En débranchant la puissance, l'ordre approprié de câblage est -48 V à -48 V, +RTN à +RTN, a alors rectifié pour rectifier. Notez que le fil de masse devrait toujours être relié d'abord et débranché pour la dernière fois. Notez que le fil de masse devrait toujours être relié d'abord et débranché pour la dernière fois.

Warnung Die Stromzufuhr ist nur mit geeigneten Ringösen an das DC Netzteil anzuschliessen. Die richtige Anschlusssequenz ist: Erdanschluss zu Erdanschluss, +RTN zu +RTN und dann -48V zu -48V. Die richtige Sequenz zum Abtrennen der Stromversorgung ist -48V zu -48V, +RTN zu +RTN und dann Erdanschluss zu Erdanschluss. Es ist zu beachten dass der Erdanschluss immer zuerst angeschlossen und als letztes abgetrennt wird.

Avvertenza Mostra la morsettiera dell'alimentatore CC. Cablare l'alimentatore CC usando i connettori adatti all'estremità del cablaggio, come illustrato. La corretta sequenza di cablaggio è da massa a massa, da positivo a positivo (da linea ad L) e da negativo a negativo (da neutro a N). Tenere presente che il filo di massa deve sempre venire collegato per primo e scollegato per ultimo.

Advarsel Riktig tilkoples tilkoplingssekvens er jord til jord, +RTN til +RTN, -48 V til -48 V. Riktig frakoples tilkoplingssekvens er -48 V til -48 V, +RTN til +RTN, jord til jord.

Aviso Ate con alambre la fuente de potencia cc Usando los terminales apropiados en el extremo del cableado. Al conectar potencia, la secuencia apropiada del cableado se muele para moler, +RTN a +RTN, entonces -48 V a -48 V. Al desconectar potencia, la secuencia apropiada del cableado es -48 V a -48 V, +RTN a +RTN, entonces molió

para moler. Observe que el alambre de tierra se debe conectar siempre primero y desconectar por último. Observe que el alambre de tierra se debe conectar siempre primero y desconectar por último.

¡Atención! Wire a fonte de alimentação de DC Usando os talões apropriados nan EXTremidade da fiação. Ao conectar a potência, a seqüência apropriada da fiação é moída para moer, +RTN a +RTN, então -48 V a -48 V. Ao desconectar a potência, a seqüência apropriada da fiação é -48 V a -48 V, +RTN a +RTN, moeu então para moer. Anote que o fio à terra deve sempre ser conectado primeiramente e desconectado por último. Anote que o fio à terra deve sempre ser conectado primeiramente e desconectado por último.

Varning! Korrekt kopplingssekvens ar jord till jord, +RTN till +RTN, -48 V till -48 V. Korrekt kopplas kopplingssekvens ar -48 V till -48 V, +RTN till +RTN, jord till jord.

DC Power Wiring Terminations Warning



WARNING: When stranded wiring is required, use approved wiring terminations, such as closed-loop or spade-type with upturned lugs. These terminations must be the appropriate size for the wires and must clamp both the insulation and conductor.

Waarschuwing Wanneer geslagen bedrading vereist is, dient u bedrading te gebruiken die voorzien is van goedgekeurde aansluitingspunten, zoals het gesloten-lus type of het grijperschop type waarbij de aansluitpunten omhoog wijzen. Deze aansluitpunten dienen de juiste maat voor de draden te hebben en dienen zowel de isolatie als de geleider vast te klemmen.

Varoitus Jos säikeellinen johdin on tarpeen, käytä hyväksyttyä johdinliitääntä, esimerkiksi suljettua silmukkaa tai kourumaista liitääntä, jossa on ylöspäin käännetyt kiinnityskorvat. Tällaisten liitääntöjen tulee olla kooltaan johtimiin sopivia ja niiden tulee puristaa yhteen sekä eristeen että johdinosan.

Avertissement Quand des fils torsadés sont nécessaires, utiliser des douilles terminales homologuées telles que celles à circuit fermé ou du type à plage ouverte avec cosses rebroussées. Ces douilles terminales doivent être de la taille qui convient aux fils et doivent être refermées sur la gaine isolante et sur le conducteur.

Warnung Wenn Litzenverdrahtung erforderlich ist, sind zugelassene Verdrahtungsabschlüsse, z.B. für einen geschlossenen Regelkreis oder gabelförmig, mit nach oben gerichteten Kabelschuhen zu verwenden. Diese Abschlüsse sollten die angemessene Größe für die Drähte haben und sowohl die Isolierung als auch den Leiter festklemmen.

Avvertenza Quando occorre usare trecce, usare connettori omologati, come quelli a occhiello o a forcella con linguette rivolte verso l'alto. I connettori devono avere la misura adatta per il cablaggio e devono serrare sia l'isolante che il conduttore.

Advarsel Hvis det er nødvendig med flertrådede ledninger, brukes godkjente ledningsavslutninger, som for eksempel lukket sløyfe eller spadetype med oppoverbøyde kabelsko. Disse avslutningene skal ha riktig størrelse i forhold til ledningene, og skal klemme sammen både isolasjonen og lederen.

Aviso Quando forem requeridas montagens de instalação eléctrica de cabo torcido, use terminações de cabo aprovadas, tais como, terminações de cabo em circuito fechado e planas com terminais de orelha voltados para cima. Estas terminações de cabo deverão ser do tamanho apropriado para os respectivos cabos, e deverão prender simultaneamente o isolamento e o fio condutor.

¡Atención! Cuando se necesite hilo trenzado, utilizar terminales para cables homologados, tales como las de tipo "bucle cerrado" o "espada", con las lengüetas de

conexión vueltas hacia arriba. Estos terminales deberán ser del tamaño apropiado para los cables que se utilicen, y tendrán que sujetar tanto el aislante como el conductor.

Varning! När flertrådiga ledningar krävs måste godkända ledningskontakter användas, t.ex. kabelsko av sluten eller öppen typ med uppåtvänd tapp. Storleken på dessa kontakter måste vara avpassad till ledningarna och måste kunna hålla både isoleringen och ledaren fastklämda.

Multiple Power Supplies Disconnection Warning



WARNING: The network device has more than one power supply connection. All connections must be removed completely to remove power from the unit completely.

Waarschuwing Deze eenheid heeft meer dan één stroomtoevoerverbinding; alle verbindingen moeten volledig worden verwijderd om de stroom van deze eenheid volledig te verwijderen.

Varoitus Tässä laitteessa on useampia virtalähdekytkentöjä. Kaikki kytkennät on irrotettava kokonaan, jotta virta poistettaisiin täysin laitteesta.

Avertissement Cette unité est équipée de plusieurs raccordements d'alimentation. Pour supprimer tout courant électrique de l'unité, tous les cordons d'alimentation doivent être débranchés.

Warnung Diese Einheit verfügt über mehr als einen Stromanschluß; um Strom gänzlich von der Einheit fernzuhalten, müssen alle Stromzufuhren abgetrennt sein.

Avvertenza Questa unità ha più di una connessione per alimentatore elettrico; tutte le connessioni devono essere completamente rimosse per togliere l'elettricità dall'unità.

Advarsel Denne enheten har mer enn én strømtilkobling. Alle tilkoblinger må kobles helt fra for å eliminere strøm fra enheten.

Aviso Este dispositivo possui mais do que uma conexão de fonte de alimentação de energia; para poder remover a fonte de alimentação de energia, deverão ser desconectadas todas as conexões existentes.

¡Atención! Esta unidad tiene más de una conexión de suministros de alimentación; para eliminar la alimentación por completo, deben desconectarse completamente todas las conexiones.

Warning! Denna enhet har mer än en strömförsörjningsanslutning; alla anslutningar måste vara helt avlägsnade innan strömtillförseln till enheten är fullständigt bruten.

TN Power Warning



WARNING: The device is designed to work with a TN power system.

Waarschuwing Het apparaat is ontworpen om te functioneren met TN energiesystemen.

Varoitus Koje on suunniteltu toimimaan TN-sähkövoimajärjestelmien yhteydessä.

Avertissement Ce dispositif a été conçu pour fonctionner avec des systèmes d'alimentation TN.

Warnung Das Gerät ist für die Verwendung mit TN-Stromsystemen ausgelegt.

Avvertenza Il dispositivo è stato progettato per l'uso con sistemi di alimentazione TN.

Advarsel Utstyret er utfomet til bruk med TN-strømsystemer.

Aviso O dispositivo foi criado para operar com sistemas de corrente TN.

¡Atención! El equipo está diseñado para trabajar con sistemas de alimentación tipo TN.

Warning! Enheten är konstruerad för användning tillsammans med elkraftssystem av TN-typ.

Agency Approvals for EX Series Switches

This topic applies to hardware devices in the EX Series product family, which includes EX Series switches, the EX Series Redundant Power System (RPS), and the XRE200 External Routing Engine.

These hardware devices comply with the following standards:

- Safety
 - CAN/CSA-C22.2 No. 60950-1 Information Technology Equipment
 - UL 60950-1 Information Technology Equipment
 - EN 60950-1 Information Technology Equipment
 - IEC 60950-1 Information Technology Equipment
 - EN 60825-1 Safety of Laser Products - Part 1: Equipment classification and requirements

- EMC
 - FCC 47CFR Part 15 Class A (USA)
 - EN 55022 Class A Emissions (Europe)
 - ICES-003 Class A
 - VCCI Class A (Japan)
 - AS/NZS CISPR 22 Class A (Australia/New Zealand)
 - CISPR 22 Class A
 - EN 55024
 - EN 300386
 - EN 61000-3-2 Power Line Harmonics
 - EN 61000-3-3 Voltage Fluctuations and Flicker
 - EN 61000-4-2 ESD
 - EN 61000-4-3 Radiated Immunity
 - EN 61000-4-4 EFT
 - EN 61000-4-5 Surge
 - EN 61000-4-6 Low Frequency Common Immunity
 - EN 61000-4-11 Voltage Dips and Sags

Compliance Statements for EMC Requirements for EX Series Switches

IN THIS SECTION

- [Canada | 281](#)
- [Taiwan | 282](#)
- [European Community | 282](#)
- [Israel | 282](#)
- [Japan | 282](#)
- [Korea | 283](#)

- United States | 283
- FCC Part 15 Statement | 283
- Nonregulatory Environmental Standards | 284

This topic applies to hardware devices in the EX Series product family, which includes EX Series switches, the EX Series Redundant Power System (RPS), and the XRE200 External Routing Engine.

This topic describes the EMC requirements for these hardware devices.

Canada

This Class A digital apparatus complies with Canadian ICES-003.

Cet appareil numérique de la classe A est conforme à la norme NMB-003 du Canada.

The Industry Canada label identifies certified equipment. This certification means that the equipment meets certain telecommunications network protective, operational, and safety requirements. Industry Canada does not guarantee the equipment will operate to the users' satisfaction.

Before installing this equipment, users should ensure that it is permissible to connect the equipment to the facilities of the local telecommunications company. The equipment must also be installed using an acceptable method of connection. In some cases, the inside wiring associated with a single line individual service can be extended by means of a certified connector assembly. The customer should be aware that compliance with the above conditions might not prevent degradation of service in some situations.

Repairs to certified equipment should be made by an authorized Canadian maintenance facility designated by the supplier. Any repairs or alterations made by the user to this equipment, or equipment malfunctions, might give the telecommunications company cause to request the user to disconnect the equipment.



CAUTION: Users should not attempt to make electrical ground connections by themselves, but should contact the appropriate inspection authority or an electrician, as appropriate.

Users should ensure for their own protection that the electrical ground connections of the power utility, telephone lines, and internal metallic water pipe system, if present, are connected together. This precaution might be particularly important in rural areas.

Taiwan

此為甲類資訊技術設備。於一般家居環境使用時，本設備可能導致射頻干擾，用戶請採取相應措施。

The preceding translates as follows:

This is a Class A device. In a domestic environment, this device might cause radio interference, in which case the user needs to take adequate measures.

European Community

This is a Class A device. In a domestic environment this device might cause radio interference, in which case the user needs to take adequate measures.

Israel

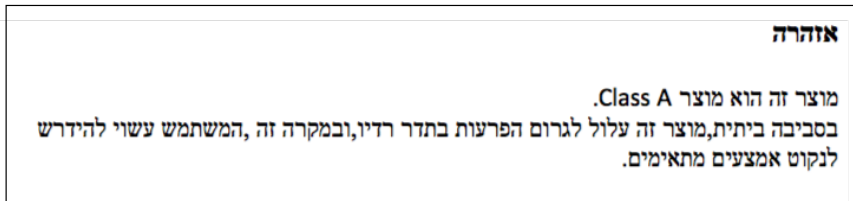

The preceding translates as follows:

Warning: This product is Class A. In residential environments, the product may cause radio interference, and in such a situation, the user may be required to take adequate measures.

Japan

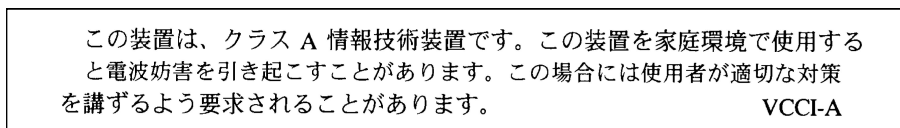

The preceding translates as follows:

This is a Class A device. In a domestic environment this device might cause radio interference, in which case the user needs to take adequate measures.

VCCI-A

Korea

이 기기는 업무용(A급) 전자파적합기기로서 판매자 또는 사용자는 이 점을 주의하시기 바라며, 가정외의 지역에서 사용하는 것을 목적으로 합니다.

Korean Class A Warning 9040913

The preceding translates as follows:

This equipment is Industrial (Class A) electromagnetic wave suitability equipment and seller or user should take notice of it, and this equipment is to be used in the places except for home

United States

The device has been tested and found to comply with the limits for a Class A digital device, pursuant to Part 15 of the FCC Rules. These limits are designed to provide reasonable protection against harmful interference when the equipment is operated in a commercial environment. This equipment generates, uses, and can radiate radio frequency energy and, if not installed and used in accordance with the instruction manual, might cause harmful interference to radio communications. Operation of this equipment in a residential area is likely to cause harmful interference, in which case users need to correct the interference at their own expense.

FCC Part 15 Statement

This equipment has been tested and found to comply with the limits for a Class A digital device pursuant to Part 15 of the FCC Rules. These limits are designed to provide reasonable protection against harmful interference in a residential installation. This equipment generates, uses, and can radiate radio frequency energy and, if not installed and used in accordance with the instructions, might cause harmful interference to radio communications. However, there is no guarantee that interference will not occur in a particular installation.

If this equipment does cause harmful interference to radio or television reception, which can be determined by turning the equipment off and on, the user is encouraged to try and correct the interference by one or more of the following measures:

- Reorient or relocate the receiving antenna.
- Increase the separation between the equipment and the receiver.
- Connect the equipment into an outlet on a circuit different from that to which the receiver is connected.
- Consult the dealer or an experienced radio or TV technician for help.

Nonregulatory Environmental Standards

NEBS compliance—These EX Series switches are Network Equipment Building System (NEBS) compliant:

- EX2200-24T and EX2200-48T
- EX3200-24T, EX3200-48T
- EX3300-24T, EX3300-48T
- EX4200-24T, EX4200-24F, EX4200-24F-S, EX4200-48T and EX4200-48T-S
- EX4300-24T, EX4300-24T-S, EX4300-24P, EX4300-24P-S, EX4300-32F, EX4300-32F-S, EX4300-48T, EX4300-48T-AFI, EX4300-48T-S, EX4300-48P, and EX4300-48P-S
- All EX4500 switches with AC power supplies
- EX4550-32T-AFO, EX4550-32T-AFI, EX4550-32F-AFO, EX4550-32F-AFI, and EX4550-32F-S
- EX4600-40F and EX4600-40F-S
- All EX6200 switches

NOTE: For the EX6200-48P line cards, the intrabuilding ports must use shielded intrabuilding cabling or wiring that is grounded at both ends.

- All EX8200 switches
- EX9251
- EX9253

These switches meet the following NEBS compliance standards:

- SR-3580 NEBS Criteria Levels (Level 4 Compliance)
- GR-1089-CORE: EMC and Electrical Safety for Network Telecommunications Equipment

- GR-63-CORE: NEBS, Physical Protection
 - The equipment is suitable for installation as part of the Common Bonding Network (CBN).
 - The equipment is suitable for installation in locations where the National Electrical Code (NEC) applies.
 - The battery return connection is to be treated as an Isolated DC return (DC-I), as defined in GR-1089-CORE.
 - You must provision a readily accessible device outside of the equipment to disconnect power. The device must also be rated based on local electrical code practice.

Compliance Statements for Acoustic Noise for EX Series Switches

This topic applies to hardware devices in the EX Series product family, which includes EX Series switches, the EX Series Redundant Power System (RPS), and the XRE200 External Routing Engine.

Maschinenlärminformations-Verordnung - 3. GPSGV, der höchste Schalldruckpegel beträgt 70 dB(A) oder weniger gemäss EN ISO 7779

Translation: The emitted sound pressure is below 70 dB(A) per EN ISO 7779.