

# YASKAWA D1000 Series

## Power Regenerative Converter

### Instruction Manual

Type: CIMR-DU

Models: 200 V Class, Three-Phase Input: 5 to 130 kW  
400 V Class, Three-Phase Input: 5 to 630 kW

To properly use the product, read this manual thoroughly and retain for easy reference, inspection, and maintenance. Ensure the end user receives this manual.

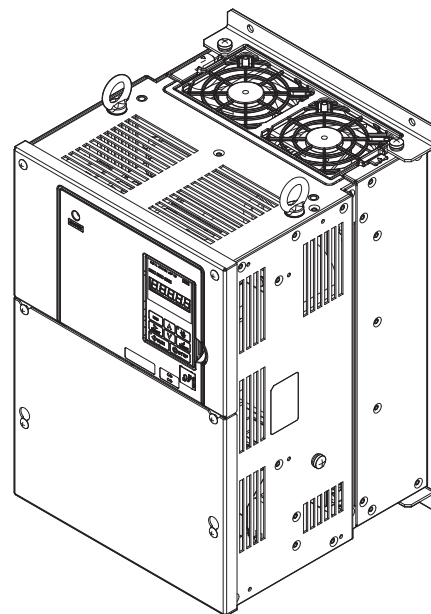

Receiving **1**

Mechanical Installation **2**

Electrical Installation **3**

Start-Up Programming & Operation **4**

Troubleshooting **5**

Periodic Inspection & Maintenance **6**

Standard Configuration Devices, Peripheral Devices, and Options **7**

Specifications **A**

Parameter List **B**

MEMOBUS/Modbus Communications **C**

Standards Compliance **D**

---

Copyright © 2013 YASKAWA ELECTRIC CORPORATION. All rights reserved.

No part of this publication may be reproduced, stored in a retrieval system, or transmitted, in any form or by any means, mechanical, electronic, photocopying, recording, or otherwise, without the prior written permission of Yaskawa. No patent liability is assumed with respect to the use of the information contained herein. Moreover, because Yaskawa is constantly striving to improve its high-quality products, the information contained in this manual is subject to change without notice. Every precaution has been taken in the preparation of this manual. Yaskawa assumes no responsibility for errors or omissions. Neither is any liability assumed for damages resulting from the use of the information contained in this publication.

# Table of Contents

<b>i. PREFACE &amp; GENERAL SAFETY .....</b>	<b>9</b>
<b>i.1 Preface .....</b>	<b>10</b>
Applicable Documentation .....	10
Symbols .....	10
Terms and Abbreviations .....	10
Trademarks .....	10
<b>i.2 General Safety .....</b>	<b>11</b>
Supplemental Safety Information .....	11
Safety Messages .....	12
General Application Precautions .....	14
Precautions on Using Peripheral Devices .....	18
Warning Label Example .....	19
Warranty Information .....	20
<b>1. RECEIVING .....</b>	<b>21</b>
<b>1.1 Section Safety .....</b>	<b>22</b>
<b>1.2 Model Numbers and Nameplates .....</b>	<b>23</b>
Nameplate .....	23
Model Numbers .....	24
<b>1.3 Converter Models and Enclosure Types .....</b>	<b>25</b>
<b>2. MECHANICAL INSTALLATION .....</b>	<b>27</b>
<b>2.1 Section Safety .....</b>	<b>28</b>
<b>2.2 Mechanical Installation .....</b>	<b>29</b>
Installation Environment .....	29
Installation Orientation and Spacing .....	30
Precautions and Instructions for Installation .....	32
Digital Operator Remote Usage .....	34
Exterior and Mounting Dimensions .....	35
<b>2.3 Harmonic Filter Module Installation .....</b>	<b>39</b>
Installation Environment .....	39
Installation Orientation and Spacing .....	40
Harmonic Filter Module Dimensions .....	42
<b>3. ELECTRICAL INSTALLATION .....</b>	<b>45</b>
<b>3.1 Section Safety .....</b>	<b>46</b>
<b>3.2 Standard Connection Diagram .....</b>	<b>48</b>

<b>3.3</b>	<b>Main Circuit Connection Diagram</b>	<b>52</b>
	CIMR-D□2A0005 to 2A0020, 4A0005 to 4A0020	52
	CIMR-D□2A0030, 2A0050, 4A0030, 4A0040, 4A0060	52
	CIMR-D□2A0065, 2A0090, 2A0130, 4A0100, 4A0130, 4A0185	53
	CIMR-D□4A0270, 4A0370	53
	CIMR-D□4A0630	53
<b>3.4</b>	<b>Terminal Block Configuration</b>	<b>54</b>
<b>3.5</b>	<b>Terminal Cover</b>	<b>57</b>
	Models 2A0005 to 2A0020, 4A0005 to 4A0020 (IP20/Open Type Enclosure)	57
	Models 2A0030 to 2A0130, 4A0030 to 4A0370 (IP00/Open Type enclosure)	58
<b>3.6</b>	<b>Digital Operator and Front Cover</b>	<b>59</b>
	Removing/Reattaching the Digital Operator	59
	Removing/Reattaching the Front Cover	59
<b>3.7</b>	<b>Main Circuit Wiring</b>	<b>61</b>
	Main Circuit Terminal Functions	61
	Protecting Main Circuit Terminals	61
	Wire Gauges and Tightening Torque	62
	Ground Wiring	66
<b>3.8</b>	<b>Harmonic Filter Module Wiring</b>	<b>67</b>
	Terminal Configuration	67
	Terminal Functions	69
	Protecting Circuit Terminals	69
	Wire Gauges and Tightening Torque	69
<b>3.9</b>	<b>Control Circuit Wiring</b>	<b>75</b>
	Control Circuit Terminal Block Functions	76
	Terminal Configuration	78
	Wiring the Control Circuit Terminal	79
<b>3.10</b>	<b>Control I/O Connections</b>	<b>81</b>
	Terminal A2 Input Signal Selection	81
	Using the Contact Outputs	82
	Connect to a PC	82
<b>3.11</b>	<b>Wiring Checklist</b>	<b>83</b>
<b>4.</b>	<b>START-UP PROGRAMMING &amp; OPERATION</b>	<b>85</b>
<b>4.1</b>	<b>Section Safety</b>	<b>86</b>
<b>4.2</b>	<b>Using the Digital Operator</b>	<b>87</b>
	LCD Display	87
	ALARM (ALM) LED Displays	88
	LO/RE LED and RUN LED Indications	88
	Menu Structure for Digital Operator	89
<b>4.3</b>	<b>The Drive and Programming Modes</b>	<b>90</b>
	Navigating the Drive and Programming Modes (Default Setting)	90
	Changing Parameter Settings or Values	91
	Verifying Parameter Changes: Verify Mode	92
	Switching Between LOCAL and REMOTE	93
<b>4.4</b>	<b>Powering Up the Converter</b>	<b>94</b>
	Powering Up the Converter and Operation Status Display	94

<b>4.5</b>	<b>Operation with the Drive Connected</b> .....	<b>95</b>
	A1000 Connection Example .....	95
	Varispeed G7 Connection Example .....	96
	Timing Chart for Turning the Power Supply On and Off .....	97
	Interlocks .....	97
<b>4.6</b>	<b>Verifying Parameter Settings and Backing Up Changes</b> .....	<b>99</b>
	Backing Up Parameter Values: o2-03 .....	99
	Parameter Access Level: A1-01 .....	99
	Password Settings: A1-04, A1-05 .....	100
	Copy Function .....	100
<b>4.7</b>	<b>Test Run Checklist</b> .....	<b>102</b>
<b>5.</b>	<b>TROUBLESHOOTING</b> .....	<b>103</b>
<b>5.1</b>	<b>Section Safety</b> .....	<b>104</b>
<b>5.2</b>	<b>Alarms, Faults, and Errors</b> .....	<b>105</b>
	Types of Alarms, Faults, and Errors .....	105
	Alarm and Error Displays .....	106
<b>5.3</b>	<b>Fault Detection</b> .....	<b>109</b>
	Fault Displays, Causes, and Possible Solutions .....	109
<b>5.4</b>	<b>Alarm Detection</b> .....	<b>120</b>
	Alarm Codes, Causes, and Possible Solutions .....	120
<b>5.5</b>	<b>Operator Programming Errors</b> .....	<b>128</b>
	Operator Programming Error Codes, Causes, and Possible Solutions .....	128
<b>5.6</b>	<b>Copy Function Related Displays</b> .....	<b>130</b>
	Tasks, Errors, and Troubleshooting .....	130
<b>5.7</b>	<b>Diagnosing and Resetting Faults</b> .....	<b>131</b>
	Fault Reset Methods .....	131
<b>6.</b>	<b>PERIODIC INSPECTION &amp; MAINTENANCE</b> .....	<b>133</b>
<b>6.1</b>	<b>Section Safety</b> .....	<b>134</b>
<b>6.2</b>	<b>Inspection</b> .....	<b>136</b>
	Recommended Daily Inspection .....	136
	Recommended Periodic Inspection .....	137
<b>6.3</b>	<b>Periodic Maintenance</b> .....	<b>139</b>
	Replacement Parts .....	139
<b>6.4</b>	<b>Cooling Fans</b> .....	<b>141</b>
	Number of Cooling Fans .....	141
	Cooling Fan Component Names .....	141
	Cooling Fan Replacement .....	143
<b>6.5</b>	<b>Converter Replacement</b> .....	<b>160</b>
	Serviceable Parts .....	160
	Terminal Board .....	160
	Replacing the Converter .....	161
<b>7.</b>	<b>STANDARD CONFIGURATION DEVICES, PERIPHERAL DEVICES, AND OPTIONS</b> .....	<b>163</b>
<b>7.1</b>	<b>Section Safety</b> .....	<b>164</b>
<b>7.2</b>	<b>Converter Options and Peripheral Devices</b> .....	<b>166</b>
<b>7.3</b>	<b>Connecting Standard Configuration Devices and Peripheral Devices</b> .....	<b>167</b>

<b>7.4</b>	<b>Standard Configuration Devices Wiring</b> .....	<b>168</b>
	Wire Gauges and Tightening Torque .....	168
<b>7.5</b>	<b>Installing Peripheral Devices</b> .....	<b>171</b>
	Installing a Molded Case Circuit Breaker (MCCB) or Ground Fault Circuit Interrupter (GFCI) .....	171
	Installing a Magnetic Contactor at the Power Supply Side .....	172
	Connecting a Surge Absorber .....	172
	Attachment for External Heatsink Mounting .....	172
<b>A.</b>	<b>SPECIFICATIONS</b> .....	<b>173</b>
<b>A.1</b>	<b>Power Ratings</b> .....	<b>174</b>
<b>A.2</b>	<b>Converter Specifications</b> .....	<b>175</b>
<b>A.3</b>	<b>Heat Loss Data</b> .....	<b>177</b>
<b>A.4</b>	<b>Derating Data</b> .....	<b>178</b>
	Temperature Derating .....	178
	Altitude Derating .....	178
<b>B.</b>	<b>PARAMETER LIST</b> .....	<b>179</b>
<b>B.1</b>	<b>Parameter Groups</b> .....	<b>180</b>
<b>B.2</b>	<b>Parameter Tables</b> .....	<b>181</b>
	A: Initialization Parameters .....	181
	b: Application .....	182
	C: Tuning .....	183
	d: References .....	184
	F: Options .....	184
	H: Multi-Function Terminals .....	186
	L: Protection Function .....	190
	o: Operator-Related Settings .....	193
	U: Monitors .....	195
<b>B.3</b>	<b>Defaults by Converter Model</b> .....	<b>202</b>
<b>C.</b>	<b>MEMOBUS/MODBUS COMMUNICATIONS</b> .....	<b>203</b>
<b>C.1</b>	<b>MEMOBUS/Modbus Configuration</b> .....	<b>204</b>
<b>C.2</b>	<b>Communication Specifications</b> .....	<b>205</b>
<b>C.3</b>	<b>Connecting to a Network</b> .....	<b>206</b>
	Network Cable Connection .....	206
	Wiring Diagram for Multiple Connections .....	207
	Network Termination .....	209
<b>C.4</b>	<b>MEMOBUS/Modbus Setup Parameters</b> .....	<b>210</b>
	MEMOBUS/Modbus Serial Communication .....	210
<b>C.5</b>	<b>Converter Operations by MEMOBUS/Modbus</b> .....	<b>213</b>
	Observing the Converter Operation .....	213
	Controlling the Converter .....	213
<b>C.6</b>	<b>Communications Timing</b> .....	<b>214</b>
	Command Messages from Master to Converter .....	214
	Response Messages from Converter to Master .....	214

<b>C.7</b>	<b>Message Format</b> .....	<b>215</b>
	Message Content .....	215
	Slave Address .....	215
	Function Code .....	215
	Data .....	215
	Error Check .....	215
<b>C.8</b>	<b>Message Examples</b> .....	<b>217</b>
	Reading Converter MEMOBUS/Modbus Register Contents .....	217
	Loopback Test .....	217
	Writing to Multiple Registers .....	218
<b>C.9</b>	<b>MEMOBUS/Modbus Data Table</b> .....	<b>219</b>
	Command Data .....	219
	Monitor Data .....	220
	Fault Trace Contents .....	227
	Alarm Register Contents .....	228
<b>C.10</b>	<b>Enter Command</b> .....	<b>229</b>
	Enter Command Types .....	229
<b>C.11</b>	<b>Communication Errors</b> .....	<b>230</b>
	MEMOBUS/Modbus Error Codes .....	230
	Slave Not Responding .....	230
<b>C.12</b>	<b>Self-Diagnostics</b> .....	<b>231</b>
<b>D.</b>	<b>STANDARDS COMPLIANCE</b> .....	<b>233</b>
<b>D.1</b>	<b>Section Safety</b> .....	<b>234</b>
<b>D.2</b>	<b>European Standards</b> .....	<b>236</b>
	CE Low Voltage Directive Compliance .....	236
	EMC Guidelines Compliance .....	238
<b>D.3</b>	<b>UL Standards</b> .....	<b>247</b>
	UL Standards .....	247
	UL Standards Compliance .....	247
	Installing Standard Configuration Devices .....	254
	Precautionary Notes on External Heatsink (IP00/Open Type enclosure) .....	254
<b>D.4</b>	<b>CSA Standards Compliance</b> .....	<b>257</b>
	Conditions of Acceptability .....	257
	Installing Standard Configuration Devices .....	257
	Main Circuit Terminal Wiring .....	257
	CSA for Industrial Control Equipment .....	257
	CSA for Elevator Equipment .....	257
	<b>Revision History</b> .....	<b>258</b>





# Preface & General Safety

---

This section provides safety messages pertinent to this product that, if not heeded, may result in fatality, personal injury, or equipment damage. Yaskawa is not responsible for the consequences of ignoring these instructions.

<b>i.1</b>	<b>PREFACE .....</b>	<b>10</b>
<b>i.2</b>	<b>GENERAL SAFETY.....</b>	<b>11</b>

## i.1 Preface

Yaskawa manufactures products used as components in a wide variety of industrial systems and equipment. The selection and application of Yaskawa products remain the responsibility of the equipment manufacturer or end user. Yaskawa accepts no responsibility for the way its products are incorporated into the final system design. Under no circumstances should any Yaskawa product be incorporated into any product or design as the exclusive or sole safety control. Without exception, all controls should be designed to detect faults dynamically and fail safely under all circumstances. All systems or equipment designed to incorporate a product manufactured by Yaskawa must be supplied to the end user with appropriate warnings and instructions as to the safe use and operation of that part. Any warnings provided by Yaskawa must be promptly provided to the end user. Yaskawa offers an express warranty only as to the quality of its products in conforming to standards and specifications published in the Yaskawa manual. **NO OTHER WARRANTY, EXPRESS OR IMPLIED, IS OFFERED.** Yaskawa assumes no liability for any personal injury, property damage, losses, or claims arising from misapplication of its products.

This manual is designed to ensure correct and suitable application of D1000-Series power regenerative converters. Read this manual before attempting to install, operate, maintain, or inspect a converter and keep it in a safe, convenient location for future reference. Be sure you understand all precautions and safety information before attempting application.

---

### ◆ Applicable Documentation

The following manuals are available for D1000 series:

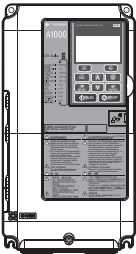
	<p>YASKAWA D1000 Series Power Regenerative Converter Instruction Manual (TOEP C710656 07)</p> <hr/> <p>This guide is packaged together with the product and contains basic information required to install and wire the converter. It also gives an fault diagnostics, maintenance, and parameter settings. The purpose of this guide is to prepare the converter for a trial run with an application and for basic operation.</p>
--	--

---

### ◆ Symbols

**Note:** Indicates a supplement or precaution that does not cause converter damage.

---

### ◆ Terms and Abbreviations

- **Conveter:** YASKAWA D1000 Series Power Regenerative Converter
- **Drive:** Yaskawa 1000-Series Drive
- **BCD:** Binary Coded Decimal
- **H:** Hexadecimal Number Format
- **IGBT:** Insulated Gate Bipolar Transistor

---

### ◆ Trademarks

- MECHATROLINK-I/MECHATROLINK-II are trademarks of MECHATROLINK Members Association (MMA).
- Other companies and product names mentioned in this manual are trademarks of those companies.

## i.2 General Safety

### ◆ Supplemental Safety Information

#### General Precautions

- The diagrams in this manual may be indicated without covers or safety shields to show details. Replace the covers or shields before operating the converter and run the converter according to the instructions described in this manual.
- Any illustrations, photographs, or examples used in this manual are provided as examples only and may not apply to all products to which this manual is applicable.
- The products and specifications described in this manual or the content and presentation of the manual may be changed without notice to improve the product and/or the manual.
- When ordering a new copy of the manual due to damage or loss, contact your Yaskawa representative or the nearest Yaskawa sales office and provide the manual number shown on the front cover.
- If nameplate becomes worn or damaged, order a replacement from your Yaskawa representative or the nearest Yaskawa sales office.

#### WARNING

Read and understand this manual before installing, operating or servicing the converter. The converter must be installed according to this manual and local codes.

The following conventions are used to indicate safety messages in this manual. Failure to heed these messages could result in serious or fatal injury or damage to the products or to related equipment and systems.

#### DANGER

Indicates a hazardous situation, which, if not avoided, will result in death or serious injury.

#### WARNING

Indicates a hazardous situation, which, if not avoided, could result in death or serious injury.

**WARNING!** may also be indicated by a bold key word embedded in the text followed by an italicized safety message.

#### CAUTION

Indicates a hazardous situation, which, if not avoided, could result in minor or moderate injury.

**CAUTION!** may also be indicated by a bold key word embedded in the text followed by an italicized safety message.

#### NOTICE

Indicates a property damage message.

**NOTICE:** may also be indicated by a bold key word embedded in the text followed by an italicized safety message.

### ◆ Safety Messages

#### DANGER

**Heed the safety messages in this manual.**

Failure to comply will result in death or serious injury.

The operating company is responsible for any injuries or equipment damage resulting from failure to heed the warnings in this manual.

#### **Electrical Shock Hazard**

**Do not install, wire, maintain, or inspect the product or replace parts while the power supply is turned on.**

Failure to comply will result in death or serious injury.

Disconnect all power to the equipment. The internal capacitor remains charged even after the power supply is turned off. After shutting off the power, wait for at least the amount of time specified on the converter before touching any components.

#### WARNING

#### **Sudden Movement Hazard**

**System may start unexpectedly upon application of power, resulting in death or serious injury.**

Clear all personnel from the converter, drive, motor and machine area before applying power to the converter. Secure covers, couplings, shaft keys and machine loads.

#### **Electrical Shock Hazard**

**Do not attempt to modify or alter the converter in any way not explained in this manual.**

Failure to comply could result in death or serious injury.

Yaskawa is not responsible for any modification of the product made by the user. This product must not be modified.

**Do not allow unqualified personnel to perform work on the converter.**

Failure to comply could result in death or serious injury.

Installation, maintenance, inspection, and servicing must be performed only by authorized personnel familiar with installation, adjustment, and maintenance of converters.

**Do not remove covers or touch circuit boards while the power is on.**

Failure to comply could result in death or serious injury.

**Always use a ground wire that complies with technical standards on electrical equipment and minimize the length of the ground wire.**

Improper equipment grounding may cause dangerous electrical potentials on equipment chassis, which could result in death or serious injury.

**Make sure the protective earthing conductor complies with technical standards and local safety regulations.**

Because the leakage current exceeds 3.5 mA in model 4A0630, IEC/EN 61800-5-1 states that either the power supply must be automatically disconnected in case of discontinuity of the protective earthing conductor or a protective earthing conductor with a cross-section of at least 10 mm<sup>2</sup> (Cu) or 16 mm<sup>2</sup> (Al) must be used. Failure to comply may result in death or serious injury.

**Always use a type B ground fault circuit interrupter GFCI according to IEC/EN 60755 when a protective residual current monitor/detection device is installed for indirect or direct shock hazard protection.**

The converter can cause a residual current with a DC component in the protective earthing conductor.

**⚠ WARNING****Do not operate equipment with covers removed.**

Failure to comply could result in death or serious injury.

**Fire Hazard****Do not use an improper voltage source.**

Failure to comply could result in death or serious injury by fire.

Verify that the rated voltage of the converter matches the voltage of the incoming power supply before applying power.

**Tighten all terminal screws to the specified tightening torque.**

Loose electrical connections could result in death or serious injury by fire due to overheating of electrical connections.

**Do not use improper combustible materials.**

Failure to comply could result in death or serious injury by fire.

Do not install the converter to a combustible surface. Never place combustible materials on the converter.

**Crush Hazard****Only allow qualified personnel to operate a crane or hoist to transport the converter.**

Failure to comply may result in serious injury or death from falling equipment.

**⚠ CAUTION****Do not carry the converter by the front cover or the terminal cover.**

Failure to comply may result in minor or moderate injury from the main body of the converter falling.

**NOTICE****Do not disconnect the wiring to the converter and harmonic filter module while the converter is outputting a voltage.**

Improper equipment sequencing could result in damage to the converter.

**Connect a power supply with a capacity (kVA) that is larger than the rated input capacity (kW) of the converter.**

Connecting a power supply with a capacity smaller than the rated input capacity may trigger an operating fault. If it is necessary to connect a power supply with a capacity smaller than the rated input capacity, consult your Yaskawa representative or the nearest Yaskawa sales office. Failure to comply may result in damage to the converter.

**Observe proper electrostatic discharge procedures (ESD) when handling the converter, circuit boards, and CMOSIC.**

Failure to comply may result in ESD damage to the converter circuitry.

**Do not perform a withstand voltage test on any part of the converter.**

Failure to comply could result in damage to the sensitive devices within the converter.

**Do not operate damaged equipment.**

Failure to comply could result in further damage to the equipment.

Do not connect or operate any equipment with visible damage or missing parts.

### NOTICE

**Install adequate branch circuit short circuit protection per applicable codes.**

Failure to comply could result in damage to the converter.

The converter is suitable for circuits capable of delivering not more than 100,000 RMS symmetrical Amperes, 240 Vac maximum (200 V Class) and 480 Vac maximum (400 V Class).

**Prevent foreign matter such as metal shavings or wire clippings from falling into the converter during converter installation and project construction.**

Failure to comply could result in damage to the converter. Place a temporary cover over the top during installation. Be sure to remove the temporary cover before start-up, as the cover will reduce ventilation and cause the converter to overheat.

**Never lift the converter up while the cover is removed.**

This can damage the terminal board and other components.

**Do not perform signal checks during operation.**

Failure to comply could result in damage to the converter.

**Do not modify the circuitry of the converter and the harmonic filter module.**

Failure to comply could result in damage to the converter and will void warranty.

Yaskawa is not responsible for any modification of the product made by the user. This product must not be modified.

**Connect the converters to power supply transformers on a 1:1 basis and use independent grounds.**

If devices, such as office equipment, that are sensitive to noise are installed in the same location, connect them while observing the grounding standards for each device, separate the ground wires, and use independent grounds or noise filters to prevent noise from entering the devices through the ground wires.

**Do not expose the converter to halogen group disinfectants.**

Failure to comply may cause damage to the electrical components in the converter.

Do not pack the converter in wooden materials that have been fumigated or sterilized.

Do not sterilize the entire package after the product is packed.

## ◆ General Application Precautions

### ■ Total Load Capacity

Select a converter with a capacity ( $P_{out}$ ) greater than the value of  $P_1$ ,  $P_2$ , or  $P_3$  shown in [Figure i.1](#).

### Selecting the Capacity

Use the following flowchart to select the converter capacity.

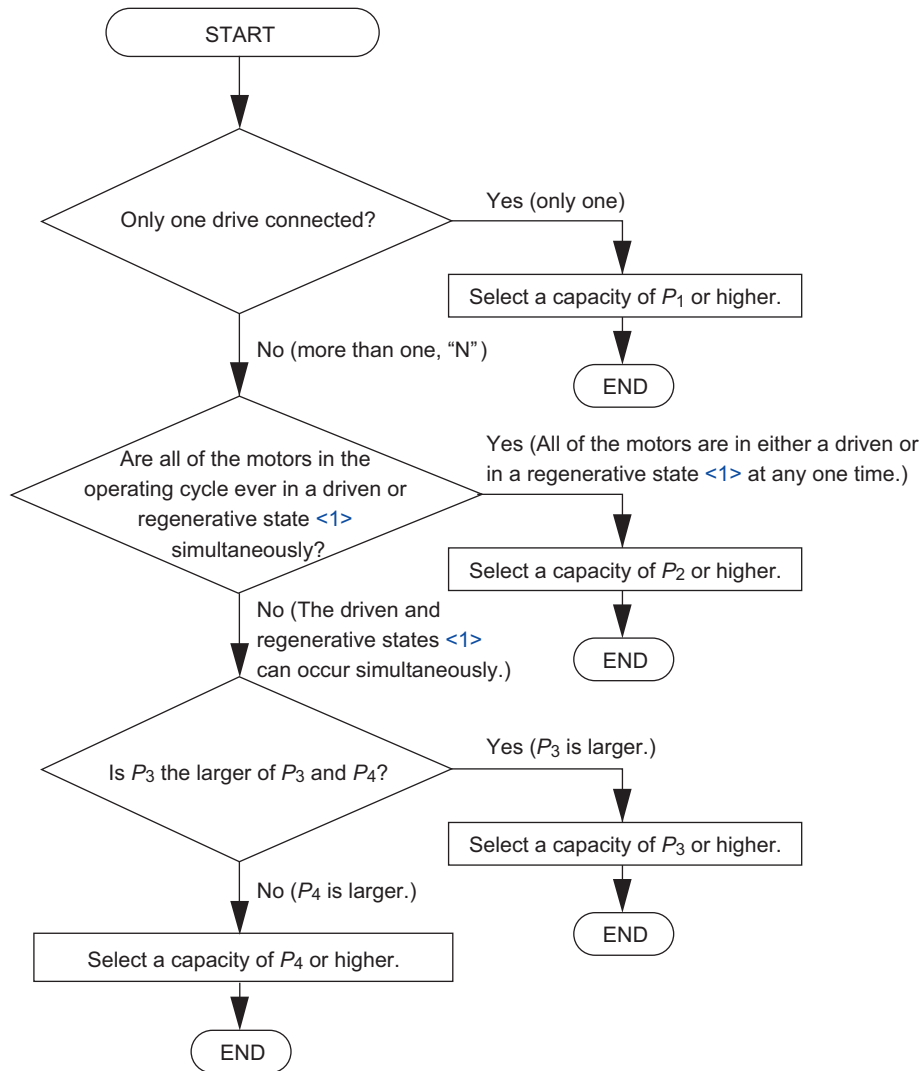

Figure i.1 Selecting the Converter Capacity

$$P_1 = \frac{\text{Motor 1 output (kW)}}{\text{Motor 1 efficiency}<2> \times \text{Drive 1 efficiency}<2>}$$

$$P_2 = \frac{\text{Motor 1 output (kW)}}{\text{Motor 1 efficiency}<2> \times \text{Drive 1 efficiency}<2>} + \frac{\text{Motor 2 output (kW)}}{\text{Motor 2 efficiency}<2> \times \text{Drive 2 efficiency}<2>} + \dots + \frac{\text{Motor N output (kW)}}{\text{Motor N efficiency}<2> \times \text{Drive N efficiency}<2>}$$

Total drive capacity<1>(or regenerative capacity <1>) (kW)

$$P_3 = P_2 - \underbrace{(\text{Motor 1 efficiency } <2> \times \text{Drive 1 efficiency } <2> \times \text{Motor 1 output (kW)} + \dots + \text{Motor N efficiency } <2> \times \text{Drive N efficiency } <2> \times \text{Motor N output (kW)})}_{\text{Total regenerative capacity } <1> \text{ (kW)}}$$

$$P_4 = 1/3 \text{ of total drive capacity (kW)}$$

<1> The drive capacity is the power capacity during a normal operating condition when energy is applied to the motor. The regenerative capacity is the capacity that is generated when the flow of power is reversed, such as when the drive is decelerated.

## i.2 General Safety

---

Example:

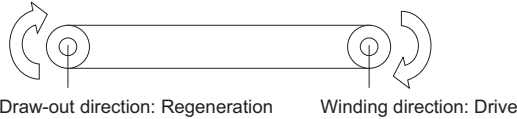

<2> Use the efficiencies of the motors and drives when known. When they are not known, use a motor efficiency of 0.9 (0.85 for 7.5 kW or less) and a drive efficiency of 0.95 (0.9 for 7.5 kW or less).

**Note:** When the interphase voltage imbalance ratio of the power source exceeds 2%, use a converter with a frame one size larger than is otherwise necessary.

Calculate the interphase voltage imbalance ratio of the power source using the following formula: (Conforms to IEC/EN 61800-3 (5.2.3).)

$$\text{Interphase imbalance ratio (\%)} = \frac{\text{Maximum voltage} - \text{Minimum voltage}}{\text{Three-phase average voltage}} \times 67$$

### Selecting the Power Supply Capacity

Connect a power supply with a capacity (kVA) that is larger than the rated input capacity (kW) of the converter.

Connecting a power supply with a capacity smaller than the rated input capacity may trigger an operating fault. If it is necessary to connect a power supply with a capacity smaller than the rated input capacity, consult your Yaskawa representative or the nearest Yaskawa sales office.

$$\text{Power supply capacity} \geq \sqrt{3} \times \text{Input power supply rated voltage} \times \text{Rated AC input current} \div 1000$$

### Installing an Input-side AC Reactor and Harmonic Filter Module

Each converter requires a corresponding input-side AC reactor and harmonic filter module that consider the saturation current and thermal factors. Always install the specified devices.

### Regenerative Converter Power Losses and Harmonic Filter Installation

Sequence the power supply for the converter so the circuit opens after the operation is stopped.

Install the specified harmonic filter (harmonic filter module) to reduce the impact of voltage surges on other devices when the circuit opens for any unexpected reason during operation. Refer to *Harmonic Filter Module Wiring on page 67* for detailed information on the harmonic filter (harmonic filter module).

### Installing a Breaker or Contactor on the Converter Output (DC) Side

Take the following precautions when installing a breaker or contactor on the converter side for an emergency shutoff.

**NOTICE: Damage to Equipment.** Confirm that the breaker or contactor on the converter output (DC) side is closed and the CHARGE indicators on the drive and converter are OFF before applying power to the converter. An overcurrent condition will occur and the device may be damaged if the power supply is turned on while there is voltage present in the drive or converter.



## ■ Installation

### Enclosure Panels

Keep the converter in a clean environment by installing the converter in an enclosure panel or selecting an installation area free of airborne dust, lint, and oil mist. Be sure to leave the required space between converters to provide for cooling, and take proper measures so the ambient temperature remains within allowable limits and keep flammable materials away from the converter. Yaskawa offers protective designs for converters that must be used in areas subjected to oil mist and excessive vibration. Contact Yaskawa or your Yaskawa agent for details.

### Installation Direction

**NOTICE:** Install the converter upright as specified in the manual. Refer to [Mechanical Installation on page 27](#) for more information on installation. Failure to comply may damage the converter due to improper cooling

### Interlock

An interlock is required between the converter and drive to stop the drive if the converter fails or if a fault occurs in the converter. It is also necessary to provide a suitable time to restart the drive if it will be restarted for momentary power losses.

Restarting can be timed with the “During MC ON” signal output from the converter control circuit terminals. Create a sequence to turn off the output from the drive with an external baseblock input to the drive or by a similar means when the “During MC ON” signal opens. For details, refer to the [Standard Connection Diagram on page 48](#).

#### Example 1: Not Restarting for Momentary Power Losses (Coasting to a Stop for Momentary Power Losses)

Connect the “During MC ON” output from the converter to the external fault input on the drive.  
Use an N.C. input for the external fault input on the drive and set the drive to detect external faults only during operation to prevent an external fault from being detected when the power supply is turned on.

#### Example 2: Restarting the System for Momentary Power Losses

Change the setting for the external baseblock input terminal S8 on the drive from the default setting of an N.O. contact to an N.C. contact.  
Connect the “During MC ON” output from the converter to the external baseblock input on the drive and set restarting for momentary power losses in the drive.

**Note:** An external baseblock is not set by default in V1000 or J1000. Set an external baseblock (N.C.) for one of the multi-function input terminals.

#### Example 3: Inputting a Run Command to the drive

Always input Run commands to the drive while the converter is operating. Check converter operating status with a During Run 1 signal on a multi-function output. Refer to [Figure 3.1 Standard Connection Diagram](#) for an example of a drive sequence.

## ■ General Handling

### Wiring Check

**NOTICE:** Do not connect power supply lines to output terminals. Failure to comply will destroy the converter or the harmonic filter module. Be sure to perform a final check of all sequence wiring and other connections before turning on the power and also check for short circuits on the control terminals, which may damage the converter.

### Inspection and Maintenance

**WARNING! Electrical Shock Hazard.** Capacitors in the converter do not immediately discharge after shutting off the power. Wait for at least the amount of time specified on the converter before touching any components after shutting off the power. Failure to comply may cause injury to personnel from electrical shock.

**WARNING! Burn Hazard.** Because the heatsink can get very hot during operation, take proper precautions to prevent burns. When replacing the cooling fan, shut off the power and wait at least 15 minutes to be sure that the heatsink has cooled down. Failure to comply may cause burn injury to personnel.

## i.2 General Safety

---

To connect or perform maintenance for the harmonic filter module, turn off the power supply to the converter, wait for the time that is given on the converter, and then confirm that the temperature of the reactor has sufficiently decreased before you proceed.

### Wiring

Yaskawa recommends using ring terminals on all models. Converters require the use of ring terminals for UL/cUL compliance. Use only the tools recommended by the terminal manufacturer for crimping.

### Transporting the Converter

**NOTICE:** *Never steam clean the converter. During transport, keep the converter from coming into contact with salts, fluorine, bromine, phthalate ester, and other such harmful chemicals.*

**CAUTION!** *Crush Hazard. Carry all standard configuration and peripheral devices in a method suitable for the weight of the device. Incorrectly handling devices could cause them to fall and result in injury or damage to the device.*

**CAUTION!** *Crush Hazard. When standing up and lifting model 4A0630, move the eye bolts to the top panel and lift the converter from the four eye bolts on the top panel. Failure to comply may cause the converter to fall and cause injury. Refer to [Precautions and Instructions for Installation on page 32](#) for details.*

---

## ◆ Precautions on Using Peripheral Devices

Install a reactor-type noise filter without a capacitor such as a zero phase reactor after the MCCB on the power supply side when installing a noise filter on the power supply.

**NOTICE:** *Do not install a filter with a built-in capacitor. The harmonic components may cause the capacitor to overheat or may damage the capacitor. Always install the specified harmonic noise filter.*

### Selecting a Circuit Breaker or Circuit Interrupter

- Yaskawa recommends installing a Ground Fault Circuit Interrupter (GFCI) to the power supply side. The GFCI should be designed for use with AC drives (e.g., Type B according to IEC/EN 60755).
- Select a Molded Case Circuit Breaker (MCCB) according to the power factor of the converter power supply. The power factor changes with the power supply voltage, output frequency, and load.

When using a GFCI that is not recommended, be sure to choose a GFCI with harmonic countermeasures and one with a rated operating current of 30 mA minimum for each connected converter. High-frequency leakage current can cause malfunctions. When a GFCI without countermeasures malfunctions, replace the GFCI with a rated operating current of 200 mA minimum for each connected converter.

Select a GFCI or MCCB with a rated trip capacity equal to or higher than the power supply short circuit current.

### Magnetic Contactor Installation

Yaskawa recommends installing a magnetic contactor (MC) between the power supply and the converter to ensure that the power to the converter can be shut off. Create a sequence in which the MC is turned off by the fault output from the converter.

### Wire Gauges and Wiring Distances

Use a motor cable gauge large enough to avoid unstable converter phase control from voltage drop caused by a long motor cable.

When using the digital operator remotely, always use the cable specified (option). When controlling the converter remotely using analog signals, limit the length of the control lines between the control signals and converter to 50 m or shorter and separate the control lines from power lines (main circuit and sequence circuits) to prevent induction from peripheral devices.

When using a multi-function analog input, connect the shield wire to the sheath ground terminal E (G) with shielded twisted-pair wires. Refer to [Standard Connection Diagram on page 48](#) for details.

### Generator Power Supplies

Select a generator with two times the capacity of the converter input power supply. Select the deceleration time, load, and other factors so that the regenerative power from the motor is 10% or less of the capacity of the generator. For details, consult with your Yaskawa representative or the nearest Yaskawa sales office.

### Connecting an Advanced-phase Capacitor or Thyristor-controlled Device to the Power Supply

An advanced-phase capacitor is not required for the converter. Installing an advanced-phase capacitor will reduce the power factor.

If an advanced-phase capacitor currently exists in the same power supply system as the converter, install a series reactor on the advanced-phase capacitor to prevent resonance with the converter.

If a device that generates voltage surge or voltage distortion, such as a thyristor-controlled DC drive or electromagnetic mixer is installed in the same power supply system as the converter, consult with your Yaskawa representative or the nearest Yaskawa sales office.

### Countermeasures for EMC and High-frequency (Harmonic) Leakage Current

Although countermeasures are not required for harmonic currents, the same countermeasures for electrical interference (EMC) and high-frequency (harmonic) leakage current are required as for a normal drive. If there are nearby devices that are easily affected by electrical interference, use a reactor-type noise filter (e.g., zero phase reactor).

When installing an MCCB or GFCI at the power supply, use an MCCB or GFCI that is designed for a drive (i.e., one that has countermeasures for high-frequency leakage current).

### Compliance with Harmonic Suppression Guidelines

- Guidelines for harmonic suppression measures are applicable to consumers that receive power from a 6.6 kV or higher system. For details, refer to the Harmonics Suppression Technical Guideline JEAG 9702-1995.
- With respect to the harmonic suppression guidelines, the converter is equivalent to a three-phase bridge that does not generate harmonics ( $K_s = 0$ ), but the harmonic component is not completely zero.

### Impact of Power Supply Distortion

Distorting the power supply voltage and connecting several devices in parallel to the same power supply will cause power supply system harmonics to flow into the converter and increase the harmonic content.

## ◆ Warning Label Example

Always heed the warning information in the position shown in [Figure i.2](#).

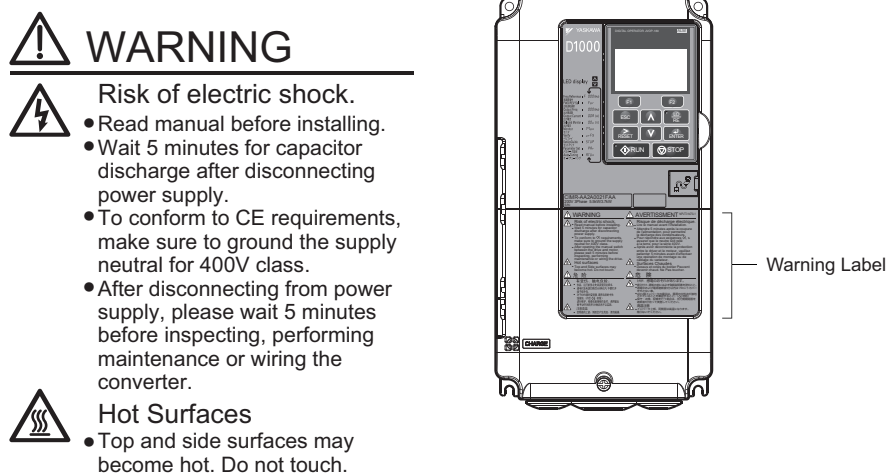

Figure i.2 Warning Information Position

### ◆ Warranty Information

#### ■ Restrictions

The converter is not designed or manufactured for use in devices or systems that may directly affect or threaten human lives or health.

Customers who intend to use the product described in this manual for devices or systems relating to transportation, health care, space aviation, atomic power, electric power, or in underwater applications must first contact their Yaskawa representatives or the nearest Yaskawa sales office.

**WARNING!** *Injury to Personnel. This product has been manufactured under strict quality-control guidelines. However, if this product is to be installed in any location where failure of this product could involve or result in a life-and-death situation or loss of human life or in a facility where failure may cause a serious accident or physical injury, safety devices must be installed to minimize the likelihood of any accident.*

## Receiving

---

This chapter explains how to inspect the converter upon receipt, and gives an overview of the different enclosure types and components.

<b>1.1</b>	<b>SECTION SAFETY</b> .....	<b>22</b>
<b>1.2</b>	<b>MODEL NUMBERS AND NAMEPLATES</b> .....	<b>23</b>
<b>1.3</b>	<b>CONVERTER MODELS AND ENCLOSURE TYPES</b> .....	<b>25</b>

## 1.1 Section Safety

### CAUTION

**Do not carry the converter by the front cover or the terminal cover.**

Failure to comply may cause the main body of the converter to fall, resulting in minor or moderate injury.

### NOTICE

**Observe proper electrostatic discharge procedures (ESD) when handling the converter and circuit boards.**

Failure to comply may result in ESD damage to circuitry.

## 1.2 Model Numbers and Nameplates

Perform the following tasks after receiving the converter and the harmonic filter module:

- Inspect the converter and the harmonic filter module for damage. If the converter or the harmonic filter module appear damaged upon receipt, contact the shipper immediately.
- Verify receipt of the correct model by checking the information on the nameplate.
- If you have received the wrong model or the converter or the harmonic filter module does not function properly, contact your supplier.

### ◆ Nameplate

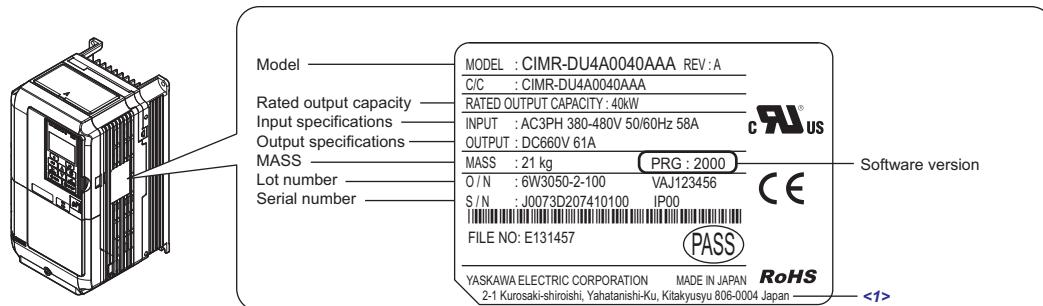

<1> The address of the head office of Yaskawa Electric Corporation (responsible for product liability) is shown on the nameplate.

Figure 1.1 Converter Nameplate Information Example

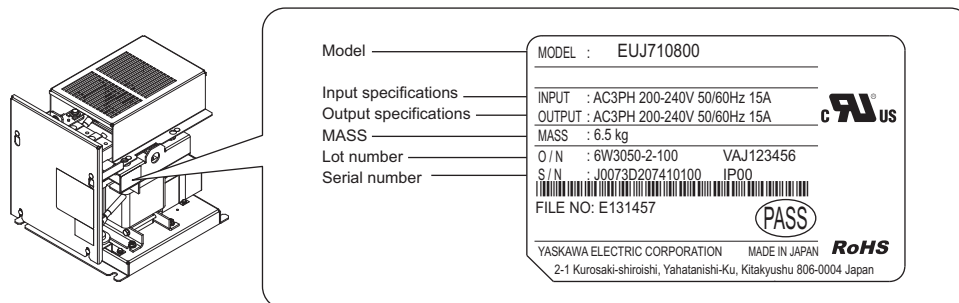
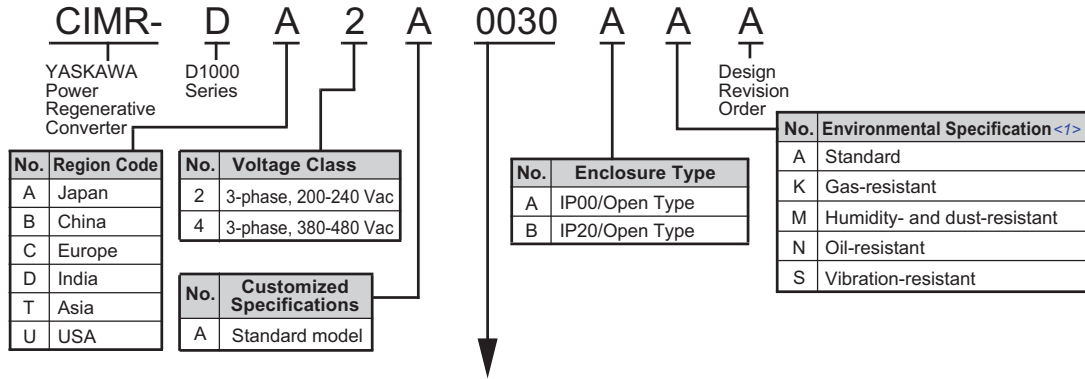

Figure 1.2 Harmonic Filter Module Nameplate Information Example

## 1.2 Model Numbers and Nameplates

### ◆ Model Numbers



Three-Phase 200 V Class

Model	Rated Output Capacity (HP)
0005	6.7
0010	13.4
0020	26.8
0030	40
0050	67
0065	87
0090	120
0130	174

Three-Phase 400 V Class

Model	Rated Output Capacity (HP)
0005	6.7
0010	13.4
0020	26.8
0030	40
0040	54.0
0060	80.0
0100	134.0
0130	174.0
0185	250
0270	360
0370	500
0630	850

<1> Converters with these specifications do not guarantee complete protection for the environmental conditions indicated.



## 1.3 Converter Models and Enclosure Types

Two types of enclosures are offered for D1000 converters:

IP00 and IP20/Open Type enclosure models are designed for installation in an enclosure panel that serves to protect personnel from injury caused by accidentally touching live parts.

*Table 1.1* describes converter enclosures and models.

**Table 1.1 Models and Enclosure Types**

Voltage Class	Enclosure Type	
	IP20/Open Type	IP00/Open Type
Three-Phase 200 V Class	2A0005	2A0030
	2A0010	2A0050
	2A0020	2A0065
	–	2A0090
	–	2A0130
Three-Phase 400 V Class	4A0005	4A0030
	4A0010	4A0040
	4A0020	4A0060
	–	4A0100
	–	4A0130
	–	4A0185
	–	4A0270
	–	4A0370
–	4A0630	



## Mechanical Installation

---

This chapter explains how to properly mount and install the converter and the harmonic filter module.

<b>2.1</b>	<b>SECTION SAFETY</b> .....	<b>28</b>
<b>2.2</b>	<b>MECHANICAL INSTALLATION</b> .....	<b>29</b>
<b>2.3</b>	<b>HARMONIC FILTER MODULE INSTALLATION</b> .....	<b>39</b>

## 2.1 Section Safety

### WARNING

#### Fire Hazard

**Ensure proper cooling when installing an IP00/IP20 converter in a closed panel or cabinet.**

Ensure the air temperature entering the converter is 50°C (122°F) or cooler by use of a cooling fan or air conditioner. Failure to comply could result in overheating and fire.

#### Crush Hazard

**Only allow qualified personnel to operate a crane or hoist to transport the converter.**

Failure to comply may result in serious injury or death from falling equipment.

**Use a dedicated lifter when transporting the converter by a lifter.**

Failure to comply may result in serious injury or death from falling equipment.

**Only use vertical suspension to temporarily lift the converter during installation to an enclosure panel.**

Do not use vertical suspension to transport the converter.

Failure to comply may result in serious injury or death from falling equipment.

**Use screws to securely affix the converter front cover, terminal blocks, and other converter components prior to vertical suspension.**

Failure to comply may result in serious injury or death from falling equipment.

**Do not subject the converter to vibration or impact greater than 1.96 m/s<sup>2</sup> (0.2 G) while it is suspended by the cables.**

Failure to comply may result in serious injury or death from falling equipment.

**Do not attempt to flip the converter over or leave the converter unattended while it is suspended by the wires.**

Failure to comply may result in serious injury or death from falling equipment.

### CAUTION

#### Crush Hazard

**Do not carry the converter by the front cover or the terminal cover.**

Failure to comply may result in minor or moderate injury from the main body of the converter falling.

## 2.2 Mechanical Installation

This section outlines specifications, procedures, and the environment for proper mechanical installation of the converter and the harmonic filter module.

### ◆ Installation Environment

Install the converter in an environment matching the specifications in [Table 2.1](#) to help prolong the optimum performance life of the converter.

**Table 2.1 Installation Environment**

Environment	Conditions
<b>Installation Area</b>	Indoors
<b>Ambient Temperature</b>	IP00/Open Type enclosure: -10°C to +50°C (14°F to 122°F) IP20/Open Type enclosure: -10°C to +40°C (14°F to 104°F) Converter reliability improves in environments without wide temperature fluctuations. When using the converter in an enclosure panel, install a cooling fan or air conditioner in the area to ensure that the air temperature inside the enclosure does not exceed the specified levels. Do not allow ice to develop on the converter or the harmonic filter module.
<b>Humidity</b>	95% RH or less and free of condensation
<b>Storage Temperature</b>	-20°C to +60°C (-4°F to +140°F)
<b>Surrounding Area</b>	Install the converter and the harmonic filter module in an area free from: <ul style="list-style-type: none"> <li>• oil mist and dust</li> <li>• metal shavings, oil, water, or other foreign materials</li> <li>• radioactive materials</li> <li>• combustible materials (e.g., wood)</li> <li>• harmful gases and liquids</li> <li>• excessive vibration</li> <li>• chlorides</li> <li>• direct sunlight.</li> </ul>
<b>Altitude</b>	1000 m (3281 ft) or lower, up to 3000 m (9843 ft) with derating. Refer to <a href="#">Derating Data on page 178</a> for details.
<b>Vibration</b>	10 to 20 Hz at 9.8 m/s <sup>2</sup> , 20 to 55 Hz at 5.9 m/s <sup>2</sup> (2A0005 to 2A0050, 4A0005 to 4A0100) 10 to 20 Hz at 9.8 m/s <sup>2</sup> , 20 to 55 Hz at 2.0 m/s <sup>2</sup> (2A0065 to 2A0130, 4A0130 to 4A0370) 10 to 20 Hz at 5.9 m/s <sup>2</sup> , 20 to 55 Hz at 2.0 m/s <sup>2</sup> (4A0630)
<b>Orientation</b>	Install the converter vertically to maintain maximum cooling effects.

**NOTICE:** Avoid placing converter peripheral devices, transformers, or other electronics near the converter as the noise created can lead to erroneous operation. If such devices must be used in close proximity to the converter, take proper steps to shield the converter from noise.

**NOTICE:** Prevent foreign matter such as metal shavings and wire clippings from falling into the converter during installation. Failure to comply could result in damage to the converter. Place a temporary cover over the top of the converter during installation. Remove the temporary cover before converter start-up, as the cover will reduce ventilation and cause the converter to overheat.

**NOTICE:** When installing an IP00/IP20 converter in a closed panel or cabinet, sufficiently cool the panel or cabinet with a cooling fan or air conditioner so that the air temperature entering the converter is 50 °C (122 °F) or cooler. Failure to comply could result in overheating and fire.

## 2.2 Mechanical Installation

### ◆ Installation Orientation and Spacing

Install the converter upright as illustrated in *Figure 2.1* to maintain proper cooling.

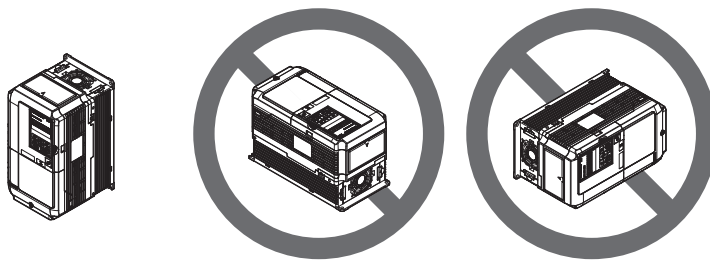
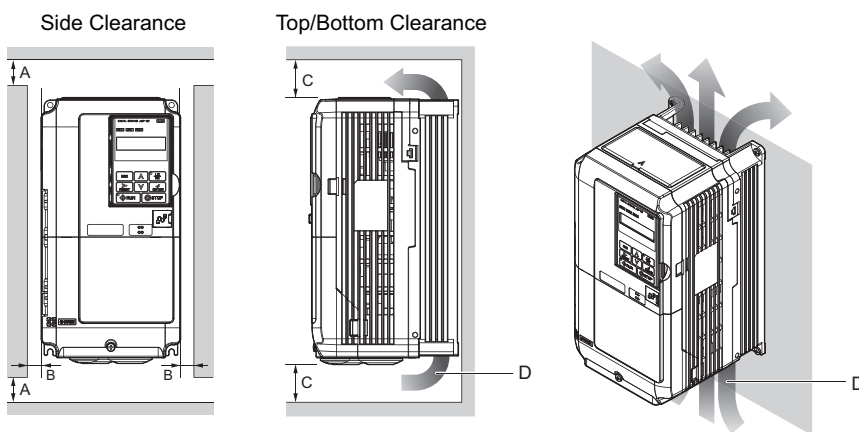

Figure 2.1 Correct Installation Orientation

### ■ Single Converter Installation

*Figure 2.2* shows the installation distance required to maintain sufficient space for airflow and wiring. Install the heatsink against a closed surface to avoid diverting cooling air around the heatsink.



A – 50 mm minimum

B – 30 mm minimum

C – 120 mm minimum

D – Airflow direction

Figure 2.2 Correct Installation Spacing (Single)

### ■ Parallel Mounting with Drive

When installing the converter beside a drive, mount the devices according to [Figure 2.3](#).

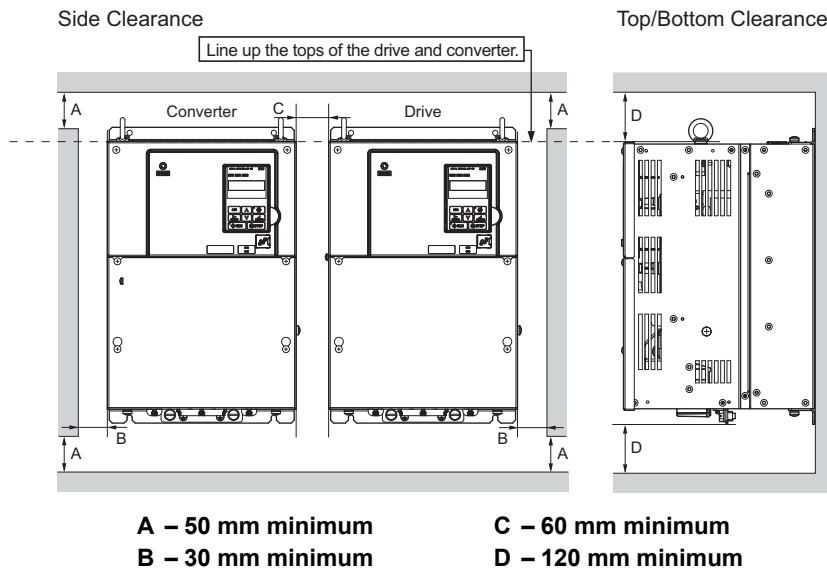

Figure 2.3 Space Between Converter and Drive (Parallel Mounting)

### ■ Side-by-Side Installation with Drive

Models 2A0005 to 2A0020 and 4A0005 to 4A0020 can take advantage of Side-by-Side installation.

When installing the converter beside a drive, mount the devices according to [Figure 2.4](#) and set L8-35, Installation Method Selection, to 1 (Side-by-Side Mounting).

When mounting converters with the minimum clearance of 2 mm according to [Figure 2.5](#), set parameter L8-35 to 1 while considering derating. Refer to [Parameter Tables on page 181](#) for details.

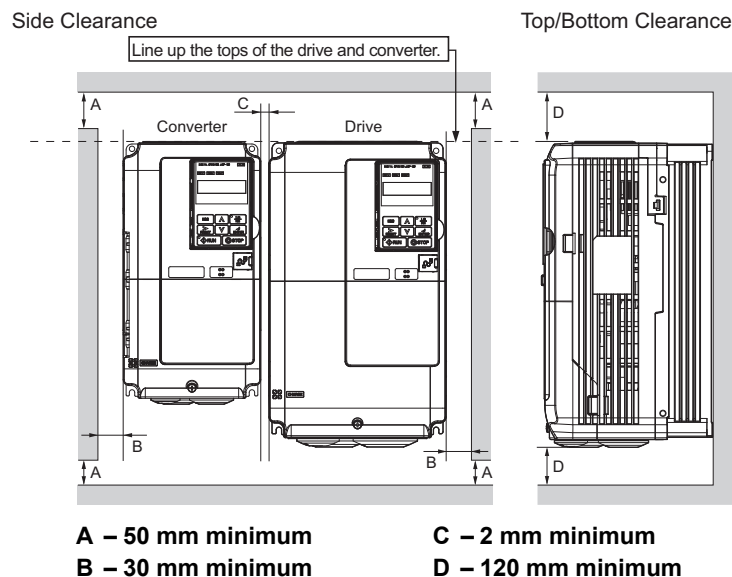

Figure 2.4 Space Between Converter and Drive (Side-by-Side)

**Note:** Align the tops of the converter and the drives when installing the converter and the drives of different heights in the same enclosure panel. Leave space between the tops and bottoms of stacked converter and drives for easier cooling fan replacement.

## 2.2 Mechanical Installation

### ■ Installation Screws

Refer to *Exterior and Mounting Dimensions on page 35* for the sizes of the installation screws.

### ◆ Precautions and Instructions for Installation

Read the following precautions and instructions before installing models 4A0270 to 4A0630.

**WARNING! Crush Hazard.** Observe the following instructions and precautions. Failure to comply could result in serious injury or death from falling equipment.

- Only use vertical suspension to temporarily lift the converter during installation to an enclosure panel.
- Do not use vertical suspension to transport the converter.
- Use screws to securely affix the converter front cover, terminal blocks, and other converter components prior to vertical suspension.
- Do not subject the converter to vibration or impact greater than  $1.96 \text{ m/s}^2$  (0.2 G) while it is suspended by the wires.
- Do not attempt to flip the converter over while it is suspended by the wires.
- Do not leave the converter unattended while it is suspended by the wires.

### ■ Horizontal Suspension of Models 2A0065 to 2A0130 and 4A0130 to 4A0370

To make a wire hanger or frame for use when lifting the converter with a crane, lay the converter in a horizontal position and pass a wire through the holes of the four eye bolts.

**NOTICE: Damage to Equipment.** When lifting the converter, confirm that the spring washer is fully closed. Failure to comply may deform or damage the converter when lifted.

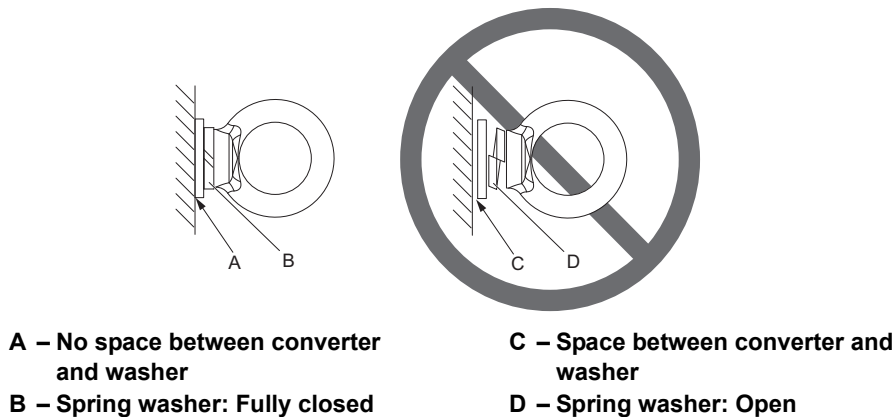

Figure 2.5 Details of Spring Washers

### ■ Vertical Suspension of Models 2A0065 to 2A0130 and 4A0130 to 4A0630

#### Models 2A0065 to 2A0130 and 4A0130 to 4A0370

When vertical suspension of the converter is required in an enclosure panel, the orientation of the eye bolts for these converter models can be easily changed by turning the eye bolts counterclockwise 90 degrees.

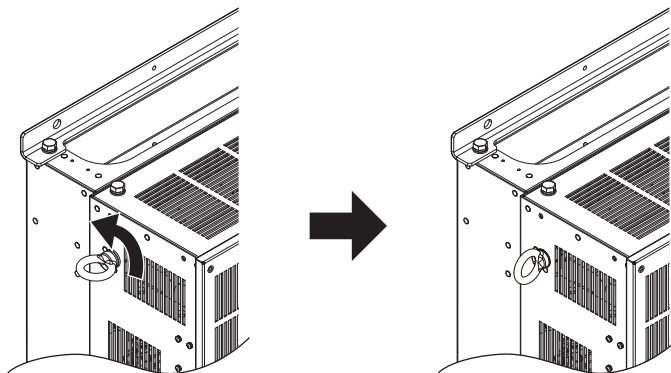

Figure 2.6 Adjusting Angle of Eye Bolts



**Model 4A0630**

When suspending model 4A0630 with wires, make sure to follow the procedure described below.

**WARNING! Crush Hazard.** Use an adequate length of wire to ensure a 50° or wider suspension angle as illustrated in [Table 2.8](#). The maximum allowable load of the eye bolts cannot be guaranteed when the converter is suspended with the wires at angles less than 50°. Failure to comply may result in serious injury or death from falling equipment.

1. Remove the four eye bolts from the converter side panels and fix them securely on the top panel.

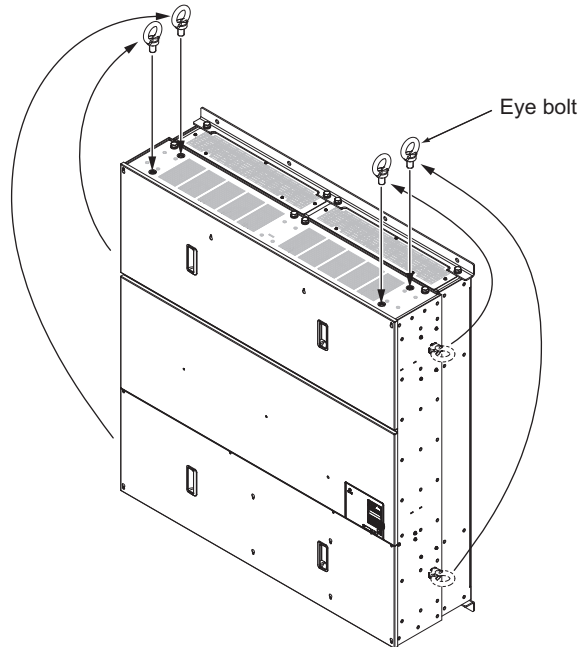

**Figure 2.7 Eye Bolt Repositioning**

2. Pass wire through the holes of all four eye bolts.

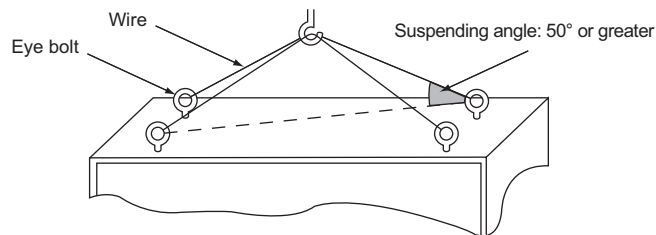

**Figure 2.8 Suspension Wire Angle Example**

3. Gradually take up the slack in the wires and hoist the converter after the wires are stretched tight.
4. Lower the converter when ready to install in the enclosure panel. Stop lowering the converter when it is near the floor then begin lowering the converter again very slowly until the converter is placed correctly.

## 2.2 Mechanical Installation

### ◆ Digital Operator Remote Usage

#### ■ Remote Operation

The digital operator mounted on the converter can be removed and connected to the converter using an extension cable up to 3 m long to facilitate operation when the converter is installed in a location where it can not be easily accessed.

The digital operator can also be permanently mounted in remote locations such as panel doors using an extension cable and an installation support set (depending on the installation type).

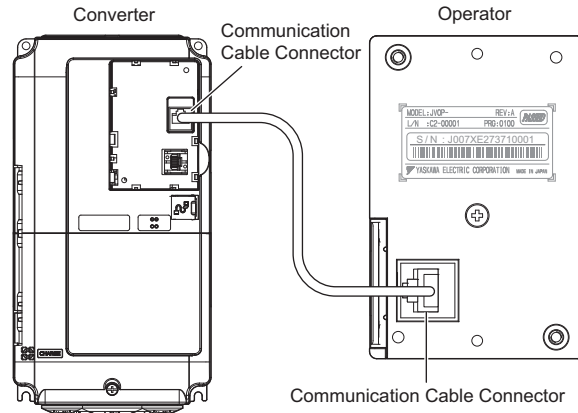

#### ■ Digital Operator Dimensions

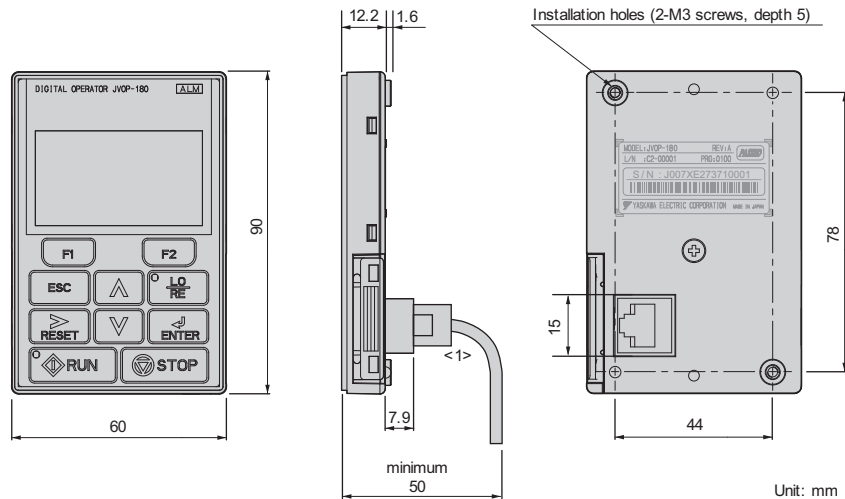

<1> If you install the digital operator in a control panel or other enclosure, use the optional connection cable.

Figure 2.9 Digital Operator Dimensions

### ■ Installation Types and Required Materials

The digital operator mounts to an enclosure two different ways:

- External/face-mount installs the operator outside the enclosure panel
- Internal/flush-mount installs the operator inside the enclosure panel

**Table 2.2 Digital Operator Installation Methods and Required Tools**

Installation Method	Description	Installation Support Sets	Model	Required Tools
External/ Face-Mount	Simplified installation with the digital operator is mounted on the outside of the panel with two screws.	–	–	Phillips screwdriver (#1)
Internal/ Flush-Mount	Encloses the digital operator in the panel. The front of the digital operator is flush with the outside of the panel.	Installation Support Set A (for mounting with screws through holes in the panel)	EZZ020642A	Phillips screwdriver (#1, #2)
		Installation Support Set B (for use with threaded studs that are fixed to the panel) </>	EZZ020642B	Phillips screwdriver (#1) Wrench (7 mm)

<1> If there are welding studs in the control panel, use the Installation Support Set B (for threaded studs).

**NOTICE:** Prevent foreign matter such as metal shavings or wire clippings from falling into the drive or converter during installation and project construction. Failure to comply could result in damage to the drive or converter. Place a temporary cover over the top of the drive and converter during installation. Remove the temporary cover before drive and converter start-up, as the cover will reduce ventilation and cause the drive or converter to overheat.

### ◆ Exterior and Mounting Dimensions

Use [Table 2.3](#) to find the converter dimension drawings.

**Table 2.3 Models and Types**

Protective Design	Converter Model		Page
	Three-Phase 200 V Class	Three-Phase 400 V Class	
IP20/Open Type Enclosure	2A0005	4A0005	36
	2A0010	4A0010	
	2A0020	4A0020	
IP00/Open Type Enclosure		4A0030	37
		4A0040	
	2A0030	4A0060	
	2A0050	4A0100	
	2A0065	4A0130	
	2A0090	4A0185	
	2A0130	4A0270	
		4A0370	
	4A0630		

## 2.2 Mechanical Installation

### ■ IP20/Open Type Enclosure Models

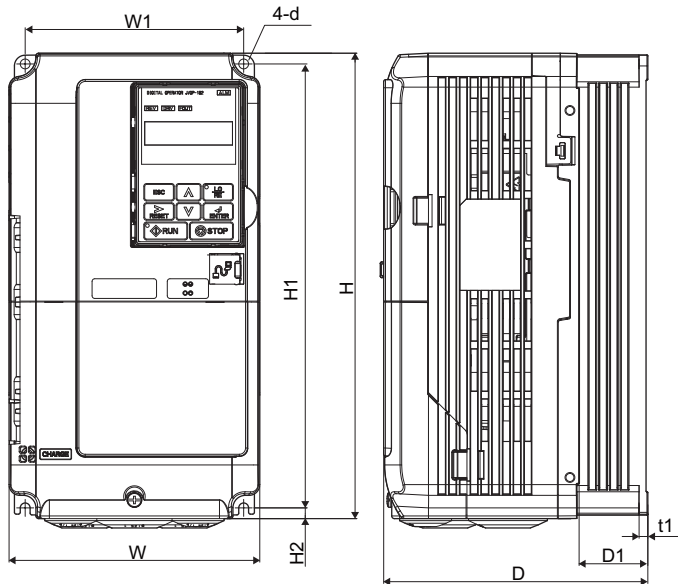

Figure 1

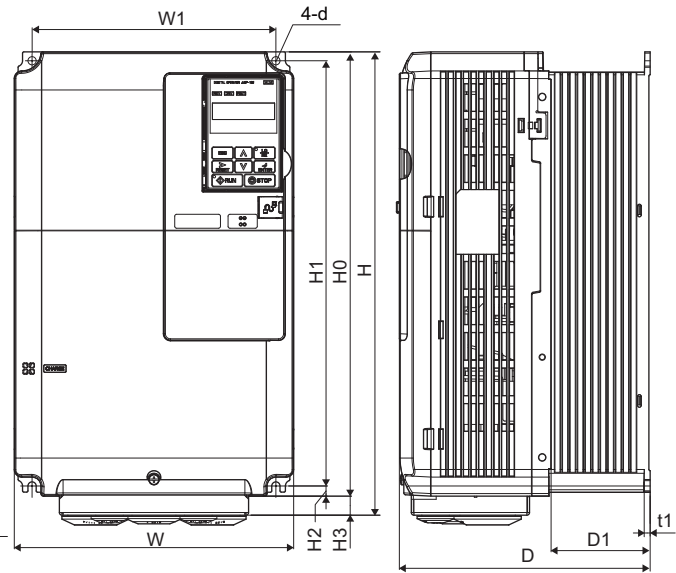

Figure 2

**Table 2.4 Dimensions for IP20/Open Type Enclosure: 200 V Class**

Model	Figure	Dimensions mm (in)											Weight kg (lb)
		W	H	D	W1	H0	H1	H2	H3	D1	t1	d	
2A0005	1	180 (7.09)	300 (11.81)	187 (7.36)	160 (6.3)	–	284 (11.18)	8 (0.31)	–	75 (2.95)	5 (0.2)	M5	5 (11.02)
2A0010	1	180 (7.09)	300 (11.81)	187 (7.36)	160 (6.3)	–	284 (11.18)	8 (0.31)	–	75 (2.95)	5 (0.2)	M5	5 (11.02)
2A0020	2	220 (8.66)	365 (14.37)	197 (7.76)	192 (7.56)	350 (13.78)	335 (13.19)	8 (0.31)	15 (0.59)	78 (3.07)	5 (0.2)	M6	8 (17.64)

**Table 2.5 Dimensions for IP20/Open Type Enclosure: 400 V Class**

Model	Figure	Dimensions mm (in)											Weight kg (lb)
		W	H	D	W1	H0	H1	H2	H3	D1	t1	d	
4A0005	1	180 (7.09)	300 (11.81)	187 (7.36)	160 (6.3)	–	284 (11.18)	8 (0.31)	–	75 (2.95)	5 (0.2)	M5	5 (11.02)
4A0010	1	180 (7.09)	300 (11.81)	187 (7.36)	160 (6.3)	–	284 (11.18)	8 (0.31)	–	75 (2.95)	5 (0.2)	M5	5 (11.02)
4A0020	2	220 (8.66)	365 (14.37)	197 (7.76)	192 (7.56)	350 (13.78)	335 (13.19)	8 (0.31)	15 (0.59)	78 (3.07)	5 (0.2)	M6	8 (17.64)

■ IP00/Open Type Enclosure Models

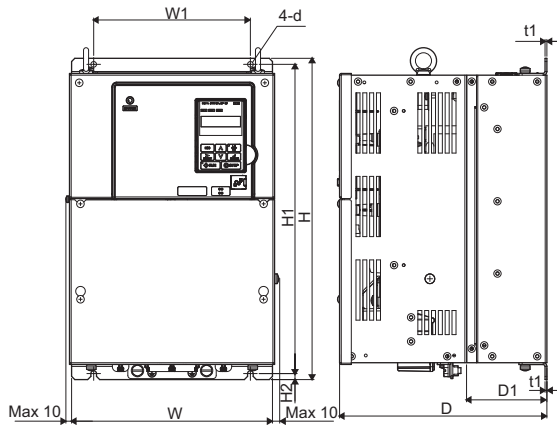

Figure 1

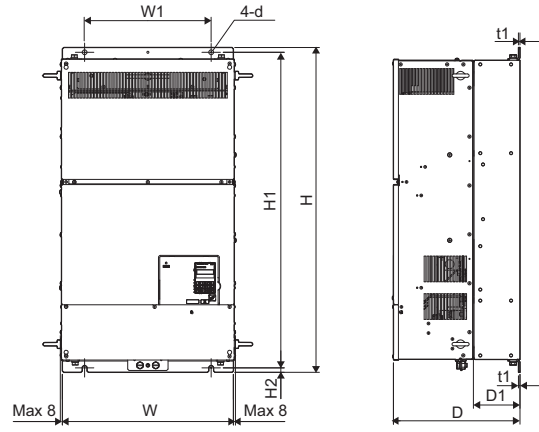

Figure 2

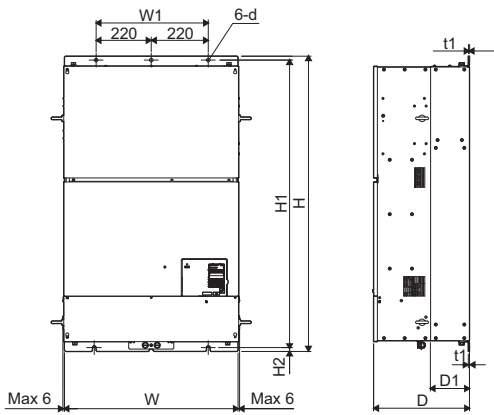

Figure 3

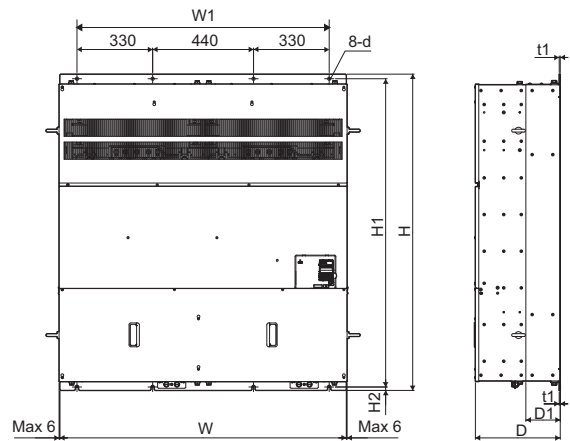

Figure 4

Table 2.6 Dimensions for IP00/Open Type Enclosure: 200 V Class

Model	Figure	Dimensions mm (in)									Weight kg (lb)
		W	H	D	W1	H1	H2	D1	t1	d	
2A0030	1	275 (10.83)	450 (17.72)	258 (10.16)	220 (8.66)	435 (17.13)	7.5 (0.3)	100 (3.94)	2.3 (0.09)	M6	20 (44.09)
2A0050	1	325 (12.8)	550 (21.65)	283 (11.14)	260 (10.24)	535 (21.06)	7.5 (0.3)	110 (4.33)	2.3 (0.09)	M6	32 (70.55)
2A0065	2	450 (17.72)	705 (27.76)	330 (12.99)	325 (12.8)	680 (26.77)	12.5 (0.49)	130 (5.12)	3.2 (0.13)	M10	57 (125.66)
2A0090	2	450 (17.72)	705 (27.76)	330 (12.99)	325 (12.8)	680 (26.77)	12.5 (0.49)	130 (5.12)	3.2 (0.13)	M10	61 (134.48)
2A0130	2	500 (19.69)	800 (31.5)	350 (13.78)	370 (14.57)	773 (30.43)	13 (0.51)	130 (5.12)	4.5 (0.18)	M12	85 (187.39)

## 2.2 Mechanical Installation

**Table 2.7 Dimensions for IP00/Open Type Enclosure: 400 V Class**

Model	Figure	Dimensions mm (in)									Weight kg (lb)
		W	H	D	W1	H1	H2	D1	t1	d	
4A0030	1	275 (10.83)	450 (17.72)	258 (10.16)	220 (8.66)	435 (17.13)	7.5 (0.3)	100 (3.94)	2.3 (0.09)	M6	21 (46.3)
4A0040	1	275 (10.83)	450 (17.72)	258 (10.16)	220 (8.66)	435 (17.13)	7.5 (0.3)	100 (3.94)	2.3 (0.09)	M6	21 (46.3)
4A0060	1	325 (12.8)	550 (21.65)	283 (11.14)	260 (10.24)	535 (21.06)	7.5 (0.3)	110 (4.33)	2.3 (0.09)	M6	34 (74.96)
4A0100	1	325 (12.8)	550 (21.65)	283 (11.14)	260 (10.24)	535 (21.06)	7.5 (0.3)	110 (4.33)	2.3 (0.09)	M6	36 (77.16)
4A0130	2	500 (19.69)	800 (31.5)	350 (13.78)	370 (14.57)	773 (30.43)	13 (0.51)	130 (5.12)	4.5 (0.18)	M12	85 (187.39)
4A0185	2	500 (19.69)	800 (31.5)	350 (13.78)	370 (14.57)	773 (30.43)	13 (0.51)	130 (5.12)	4.5 (0.18)	M12	85 (187.39)
4A0270	3	670 (26.38)	1140 (44.88)	370 (14.57)	440 (17.32)	1110 (43.7)	15 (0.59)	150 (5.91)	4.5 (0.18)	M12	183 (403.45)
4A0370	3	670 (26.38)	1140 (44.88)	370 (14.57)	440 (17.32)	1110 (43.7)	15 (0.59)	150 (5.91)	4.5 (0.18)	M12	194 (427.7)
4A0630	4	1250 (49.21)	1380 (54.33)	370 (14.57)	1100 (43.31)	1345 (52.95)	15 (0.59)	150 (5.91)	4.5 (0.18)	M12	413 (910.51)

## 2.3 Harmonic Filter Module Installation

### ◆ Installation Environment

Install the harmonic filter module in an environment matching the specifications in [Table 2.8](#) to help prolong the optimum performance life of the harmonic filter module.

**Table 2.8 Installation Environment**

Environment	Conditions
<b>Installation Area</b>	Indoors Install the converter in an environment that does not easily accessible such as control panel.
<b>Ambient Temperature</b>	IP00/Open Type enclosure: -10°C to +50°C (14°F to 140°F) Harmonic filter module reliability improves in environments without wide temperature fluctuations. When using the harmonic filter module in an enclosure panel, install a cooling fan or air conditioner in the area to ensure that the air temperature inside the enclosure does not exceed the specified levels. Do not allow ice to develop on the harmonic filter module.
<b>Humidity</b>	95% RH or less and free of condensation
<b>Storage Temperature</b>	-20°C to +60°C (-4°F to +140°F)
<b>Surrounding Area</b>	Install the harmonic filter module in an area free from: <ul style="list-style-type: none"> <li>• oil mist and dust</li> <li>• metal shavings, oil, water, or other foreign materials</li> <li>• radioactive materials</li> <li>• combustible materials (e.g., wood)</li> <li>• harmful gases and liquids</li> <li>• excessive vibration</li> <li>• chlorides</li> <li>• direct sunlight.</li> </ul>
<b>Altitude</b>	3000 m (9843 ft) or lower
<b>Vibration</b>	2.0 m/s <sup>2</sup> (20 to 55 Hz)

**WARNING! Fire Hazard.** When installing an IP00/IP20 converter in a closed panel or cabinet, sufficiently cool the panel or cabinet with a cooling fan or air conditioner so that the air temperature entering the converter is 50 °C (122 °F) or cooler. Failure to comply could result in overheating and fire.

**NOTICE:** Avoid placing converter peripheral devices, transformers, or other electronics near the converter as the noise created can lead to erroneous operation. If such devices must be used in close proximity to the converter, take proper steps to shield the converter from noise.

**NOTICE:** Prevent foreign matter such as metal shavings and wire clippings from falling into the converter and harmonic filter module during installation. Failure to comply could result in damage to the converter and the harmonic filter module. Place a temporary cover over the top of the converter and the harmonic filter module during installation. Remove the temporary cover before converter and harmonic filter module start-up, as the cover will reduce ventilation and cause the converter and the harmonic filter module to overheat.

## 2.3 Harmonic Filter Module Installation

### ◆ Installation Orientation and Spacing

#### ■ Installation Orientation

Install the harmonic filter module on the floor with the faceplate facing forward.

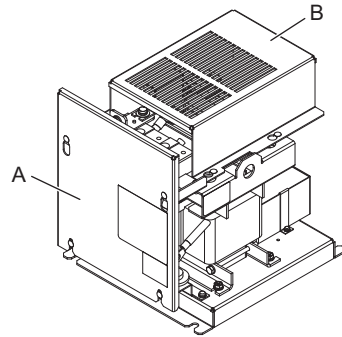

A – Faceplate

B – Top cover

Figure 2.10 Correct Installation Orientation

#### ■ Installation Spacing

Figure 2.11 shows the installation distance required to maintain sufficient space for airflow and wiring.

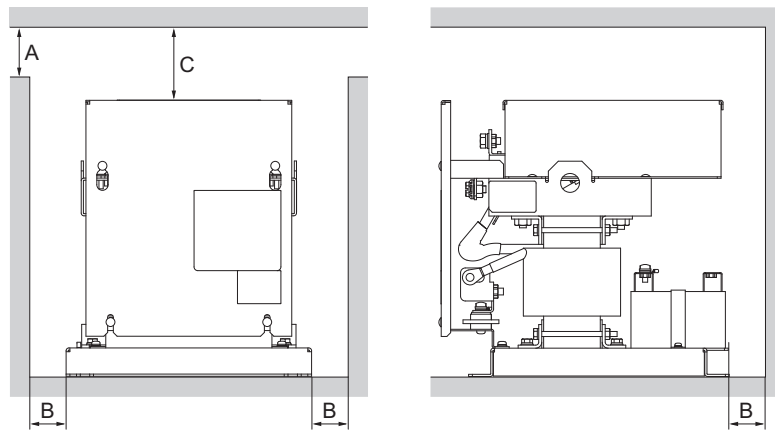

A – 50 mm minimum

B – 30 mm minimum

C – 120 mm minimum

Figure 2.11 Installation Spacing



### ■ Precautions and Instructions for Installation of Harmonic Filter Module

Read the following precautions and instructions before installing a harmonic filter module.

**WARNING!** Always observe the following precautions. If handled incorrectly, the harmonic filter module may fall, possibly causing injury. Also, the harmonic filter module may be damaged.

- Suspend the harmonic filter module with wires only temporarily and only when installing them in a control panel. Do not suspend them when transporting them.
- Before you suspend the harmonic filter module, confirm that faceplate, top cover, and other configuration components are securely screwed in place.
- Do not place the harmonic filter module on its side.
- Do not leave the harmonic filter module suspended with wires for a long period of time.

**CAUTION!** Hold the specified locations when carrying a harmonic filter module by hand. Holding any other location when carrying the harmonic filter module could cause the module could fall and cause injury.

**NOTICE:** Do not disconnect the wiring to the converter and harmonic filter module while the converter is outputting a voltage. Improper equipment sequencing could result in damage to the converter.

Attach hooks to the specified locations when suspending the harmonic filter module with wires.

**NOTICE:** Do not apply excessive force to the top cover when suspending the harmonic filter. The top cover may be deformed. When lifting the module by hand, always use the holding frames and use two people. Failure to comply may damage the module.

Refer to *Figure 2.12* and *Figure 2.13* for details.

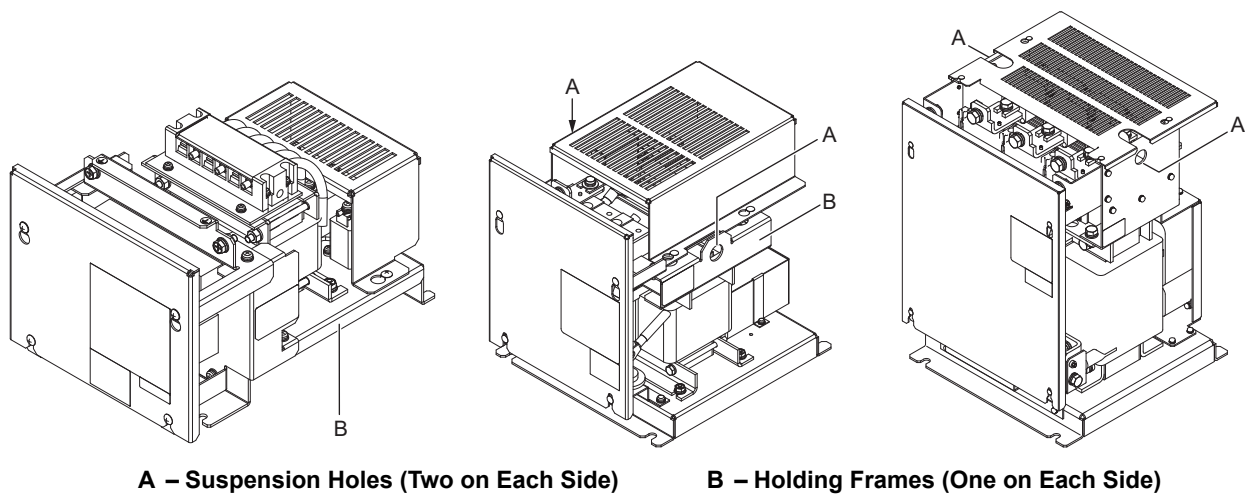

**Figure 2.12** Suspension Locations for the Harmonic Filter Module

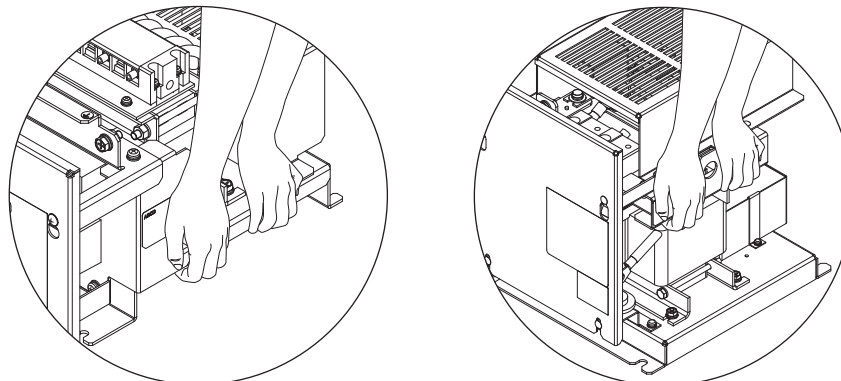

**Figure 2.13** Holding the Harmonic Filter Module

### ◆ Harmonic Filter Module Dimensions

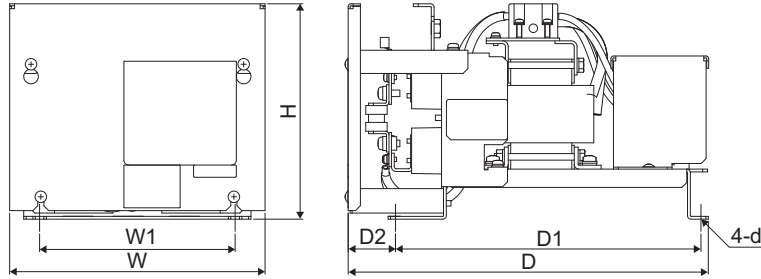

Figure 1

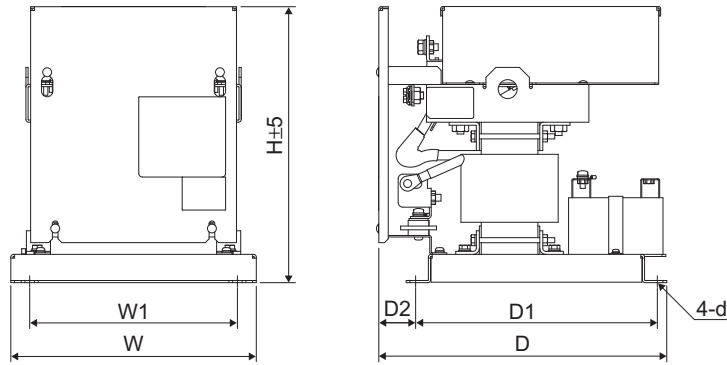

Figure 2

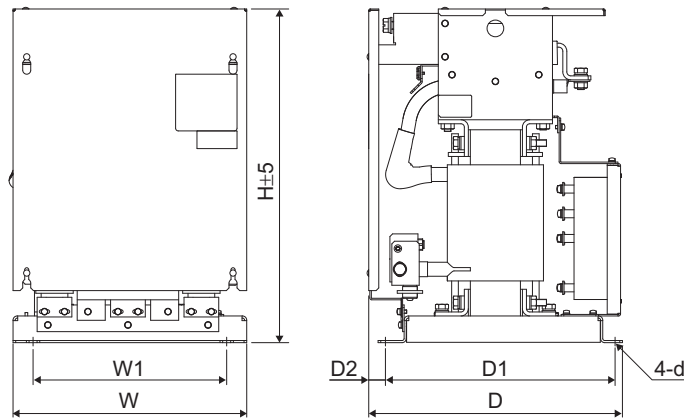

Figure 3

Table 2.9 Dimensions for IP00/Open Type enclosure: 200 V Class

Model	Figure	Dimensions mm (in)							Weight kg (lb)
		W	H	D	W1	D1	D2	d	
EUJ71080□	1	209 (8.23)	176 (6.93)	285 (11.22)	160 (6.3)	240 (9.45)	39 (1.54)	M6	6.5 (14.33)
EUJ71081□	1	209 (8.23)	184 (7.24)	295 (11.61)	160 (6.3)	250 (9.84)	39 (1.54)	M6	9 (19.84)
EUJ71082□	2	232 (9.13)	265 (10.43)	301 (11.85)	203 (7.99)	247 (9.72)	44 (1.73)	M8	14 (30.86)
EUJ71083□	2	260 (10.24)	281 (11.06)	305 (12.01)	220 (8.66)	256 (10.08)	39 (1.54)	M8	16 (35.27)
EUJ71084□	2	290 (11.42)	348 (13.7)	355 (13.98)	250 (9.84)	314 (12.36)	30 (1.18)	M10	27 (59.52)
EUJ71085□	3	290 (11.42)	350 (13.78)	352 (13.86)	254 (10)	314 (12.36)	27 (1.06)	M10	38 (83.78)
EUJ71086□	3	290 (11.42)	387 (15.24)	352 (13.86)	254 (10)	314 (12.36)	27 (1.06)	M10	43 (94.8)
EUJ71087□	3	350 (13.78)	500 (19.69)	380 (14.96)	290 (11.42)	350 (13.78)	19 (0.75)	M10	62 (136.7)

Table 2.10 Dimensions for IP00/Open Type enclosure: 400 V Class

Model	Figure	Dimensions mm (in)							Weight kg (lb)
		W	H	D	W1	D1	D2	d	
EUJ71088□	1	209 (8.23)	176 (6.93)	285 (11.22)	160 (6.3)	240 (9.45)	39 (1.54)	M6	7 (15.43)
EUJ71089□	1	209 (8.23)	178 (7.01)	295 (11.61)	160 (6.3)	250 (9.84)	39 (1.54)	M6	9 (19.84)
EUJ71090□	2	232 (9.13)	265 (10.43)	301 (11.85)	203 (7.99)	247 (9.72)	44 (1.73)	M8	15 (33.07)
EUJ71091□	2	260 (10.24)	293 (11.54)	305 (12.01)	220 (8.66)	256 (10.08)	39 (1.54)	M8	17 (37.48)
EUJ71092□	2	260 (10.24)	293 (11.54)	305 (12.01)	220 (8.66)	256 (10.08)	39 (1.54)	M8	19 (41.89)
EUJ71093□	2	290 (11.42)	348 (13.7)	355 (13.98)	250 (9.84)	314 (12.36)	30 (1.18)	M10	27 (59.52)
EUJ71094□	2	290 (11.42)	385 (15.16)	355 (13.98)	250 (9.84)	314 (12.36)	30 (1.18)	M10	39 (85.98)
EUJ71095□	3	350 (13.78)	500 (19.69)	380 (14.96)	290 (11.42)	350 (13.78)	19 (0.75)	M10	64 (141.1)
EUJ71096□	3	350 (13.78)	500 (19.69)	380 (14.96)	290 (11.42)	344 (13.54)	25 (0.98)	M10	73 (160.94)

### 2.3 Harmonic Filter Module Installation

---

# Electrical Installation

---

This chapter explains proper procedures for wiring the control circuit terminals, motor, and power supply.

<b>3.1</b>	<b>SECTION SAFETY</b> .....	<b>46</b>
<b>3.2</b>	<b>STANDARD CONNECTION DIAGRAM</b> .....	<b>48</b>
<b>3.3</b>	<b>MAIN CIRCUIT CONNECTION DIAGRAM</b> .....	<b>52</b>
<b>3.4</b>	<b>TERMINAL BLOCK CONFIGURATION</b> .....	<b>54</b>
<b>3.5</b>	<b>TERMINAL COVER</b> .....	<b>57</b>
<b>3.6</b>	<b>DIGITAL OPERATOR AND FRONT COVER</b> .....	<b>59</b>
<b>3.7</b>	<b>MAIN CIRCUIT WIRING</b> .....	<b>61</b>
<b>3.8</b>	<b>HARMONIC FILTER MODULE WIRING</b> .....	<b>67</b>
<b>3.9</b>	<b>CONTROL CIRCUIT WIRING</b> .....	<b>75</b>
<b>3.10</b>	<b>CONTROL I/O CONNECTIONS</b> .....	<b>81</b>
<b>3.11</b>	<b>WIRING CHECKLIST</b> .....	<b>83</b>

## 3.1 Section Safety

### DANGER

#### Electrical Shock Hazard

**Do not connect or disconnect wiring while the power is on.**

Failure to comply will result in death or serious injury.

**Do not turn on the power supply or supply power to the input-side AC reactor or to the harmonic filter (harmonic filter module) only.**

Voltage will remain in the internal capacitor and will result in death or serious injury. Always connect a converter as shown in the Standard Connection Diagram before you turn on the power supply.

### WARNING

#### Electrical Shock Hazard

**Do not operate equipment with covers removed.**

Failure to comply could result in death or serious injury.

The diagrams in this section may show converter without covers or safety shields to show details. Be sure to reinstall covers or shields before operating the converter and run the converter according to the instructions described in this manual.

**Always use a type B ground fault circuit interrupter GFCI according to IEC/EN 60755 when a protective residual current monitor/detection device is installed for indirect or direct shock hazard protection.**

The converter can cause a residual current with a DC component in the protective earthing conductor.

**Do not perform work on the converter while wearing loose clothing, jewelry or without eye protection.**

Failure to comply could result in death or serious injury.

Remove all metal objects such as watches and rings, secure loose clothing, and wear eye protection before beginning work on the converter.

**Do not remove covers or touch circuit boards while the power is on.**

Failure to comply could result in death or serious injury.

**Do not allow unqualified personnel to perform work on the converter.**

Failure to comply could result in death or serious injury.

Installation, maintenance, inspection, and servicing must be performed only by authorized personnel familiar with installation, adjustment, and maintenance of this equipment.

**Do not touch any terminals before the capacitors have fully discharged.**

Failure to comply could result in death or serious injury.

Before wiring terminals, disconnect all power to the equipment. The internal capacitor remains charged even after the power supply is turned off. After shutting off the power, wait for at least the amount of time specified on the converter before touching any components.

#### Fire Hazard

**Tighten all terminal screws to the specified tightening torque.**

Loose electrical connections could result in death or serious injury by fire due to overheating of electrical connections.

**⚠ WARNING****Do not use improper combustible materials.**

Failure to comply could result in death or serious injury by fire.

Do not install the converter to a combustible surface. Never place combustible materials on the converter.

**Do not use an improper voltage source.**

Failure to comply could result in death or serious injury by fire.

Verify that the rated voltage of the converter matches the voltage of the incoming power supply before applying power.

**When installing options, perform all wiring exactly as specified in the wiring diagrams provided.**

Failure to do so can result in fire. Improper wiring may damage option components.

**⚠ CAUTION****Crush Hazard****Do not carry the converter by the front cover or the terminal cover.**

Failure to comply may result in minor or moderate injury from the main body of the converter falling.

**NOTICE****Observe proper electrostatic discharge procedures (ESD) when handling the converter and circuit boards.**

Failure to comply may result in ESD damage to the converter circuitry.

**Do not use unshielded cable for control wiring.**

Failure to comply may cause electrical interference resulting in poor system performance. Use shielded, twisted-pair wires and ground the shield to the shield ground terminal E (G) of the converter.

**Do not modify the converter circuitry.**

Failure to comply could result in damage to the converter and will void warranty.

Yaskawa is not responsible for any modification of the product made by the user. This product must not be modified.

**Check all the wiring to ensure that all connections are correct after installing the converter and connecting any other devices.**

Failure to comply could result in damage to the converter.

**Check all the wiring to ensure that all connections are correct after installing the converter and connecting any other devices.**

Failure to comply could result in damage to the converter.

### 3.2 Standard Connection Diagram

Connect the converter and peripheral devices as shown in *Figure 3.1* and *Figure 3.2*. It is possible to set and run the converter via the digital operator without connecting digital I/O wiring. This section does not discuss converter operation; Refer to *Start-Up Programming & Operation on page 85* for instructions on operating the converter. Refer to *A1000 Connection Example on page 95* for connection with a drive.

**WARNING!** *Sudden Movement Hazard. Ensure start/stop and safety circuits are wired properly and in the correct state before energizing the converter. Failure to comply could result in death or serious injury from moving equipment.*

**NOTICE:** *If unsuitable wiring is performed, the converter could be damaged. Implement protection for branches and short-circuits according to all national and local standards.*

**NOTICE:** *Do not connect AC control circuit ground to converter enclosure. Improper grounding can cause control circuit malfunction.*

**NOTICE:** *Route motor leads U/T1, V/T2, and W/T3 separate from all other leads to reduce possible interference related issues. Failure to comply may result in abnormal operation of drive and nearby equipment.*

**NOTICE:** *The minimum load for the relay outputs M1-M2, M3-M4, M5-M6 and MA-MB-MC is 10 mA.*

**NOTICE:** *When installing a noise filter on the converter power supply, use a reactor-type noise filter (without a capacitor), such as a zero phase reactor, and install it after the MCCB on the power supply side. Do not install a filter with a built-in capacitor as the harmonic components may cause the capacitor to overheat or may damage the capacitor.*

**NOTICE:** *When installing a breaker or contactor on the converter side for an emergency shutoff, confirm that the CHARGE indicators on the drive and converter are not lit before closing the breaker or contactor on the converter output (DC) side. If the power supply is turned on while there is a voltage charge, an overcurrent will flow and the device may be damaged. Always confirm that the breaker or contactor on the converter output (DC) side is turned on before applying power to the converter.*



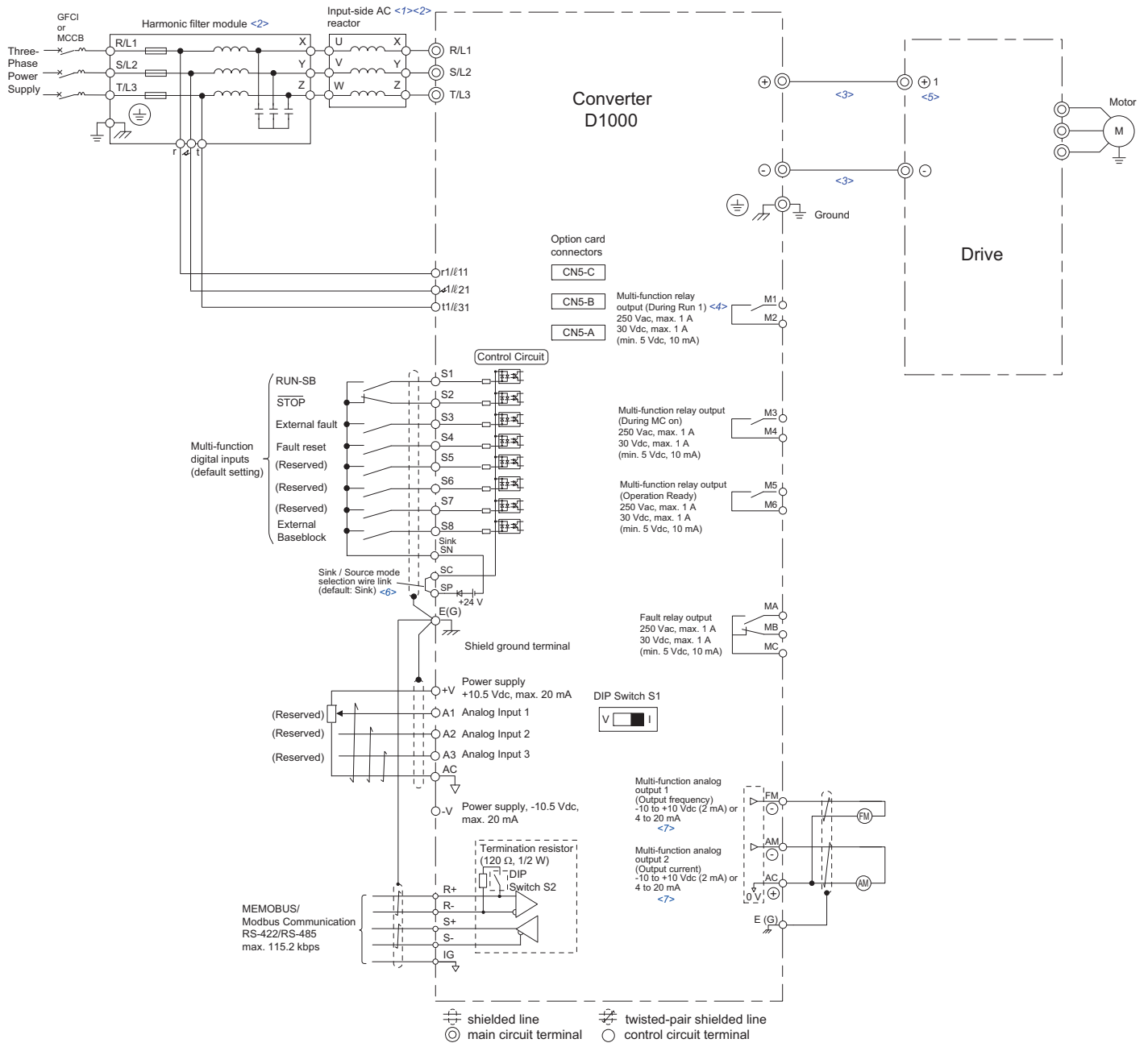

**Figure 3.1 Standard Connection Diagram (example: model 2A0030 to 2A0130, and 4A0030 to 4A0185)**

- <1> Do not use a line longer than 10 m (32.8 ft) to connect the input-side AC reactor and the converter.
- <2> Use the specified AC reactor and harmonic filter module. Non-specified devices may cause erroneous operation.
- <3> Do not use a DC bus line that is longer than 5 m (16.4 ft) to connect the converter and drive.
- <4> Sequence the operation so that the converter starts operation before the drive when power is applied. Sequence the stopping operation to turn off the drive first, then the motor, and finally the converter. Operating the drive without operating the converter or turning off the power supply unit during operation may trigger a converter fault.
- <5> Do not connect a power supply to the drive AC power supply terminals (R/L1, S/L2, and T/L3).
- <6> The connections are shown for sequence connections with no-voltage contacts or NPN transistors for the sequence input signals (S1 to S8). Use jumper S3 to select between Sink mode and Source mode. The default setting is Sink mode.
- <7> Multi-function analog outputs work with devices such as analog frequency meters, ammeters, voltmeters, and wattmeters. They are not intended for use as a feedback-type signal.

## 3.2 Standard Connection Diagram

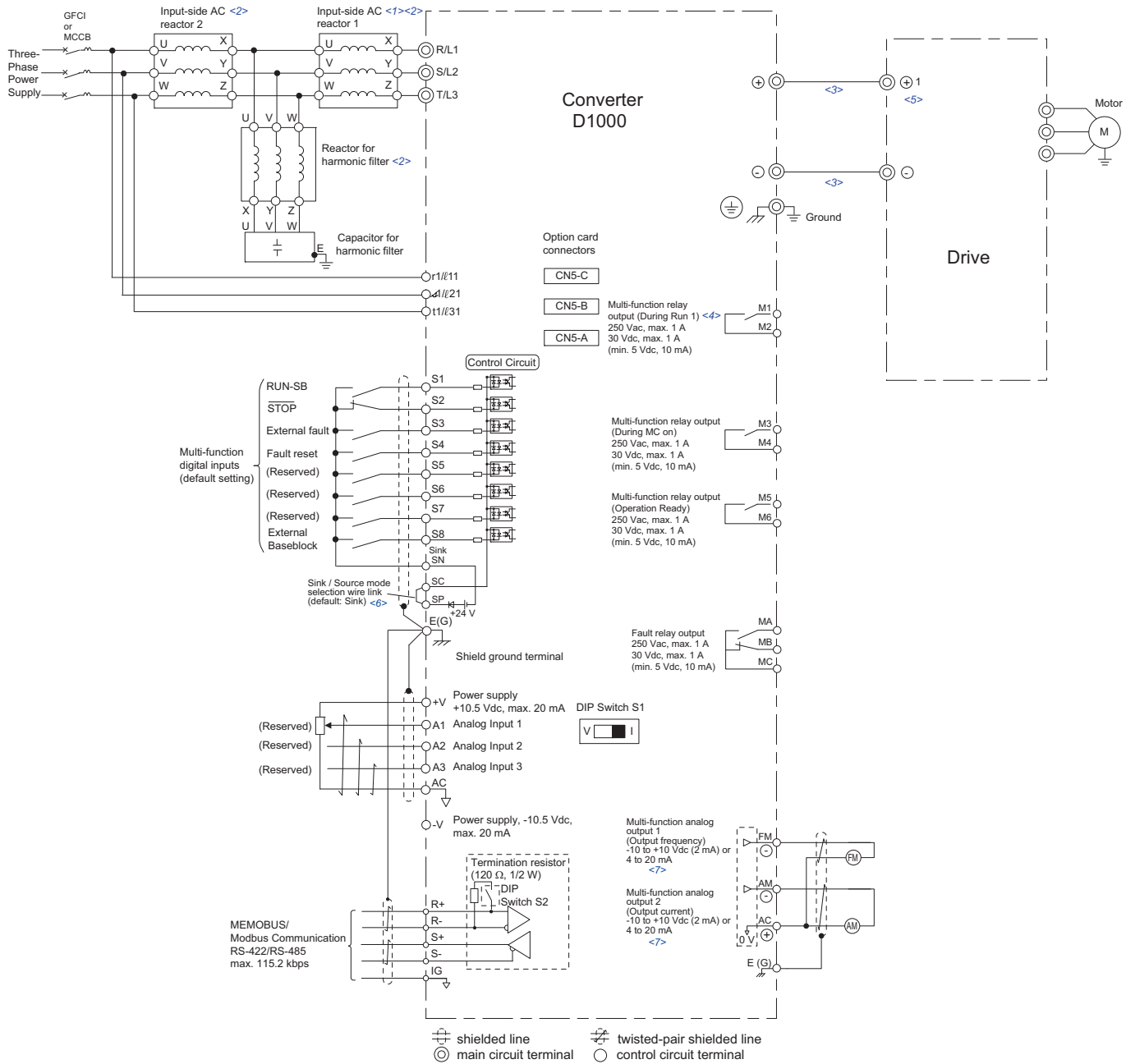
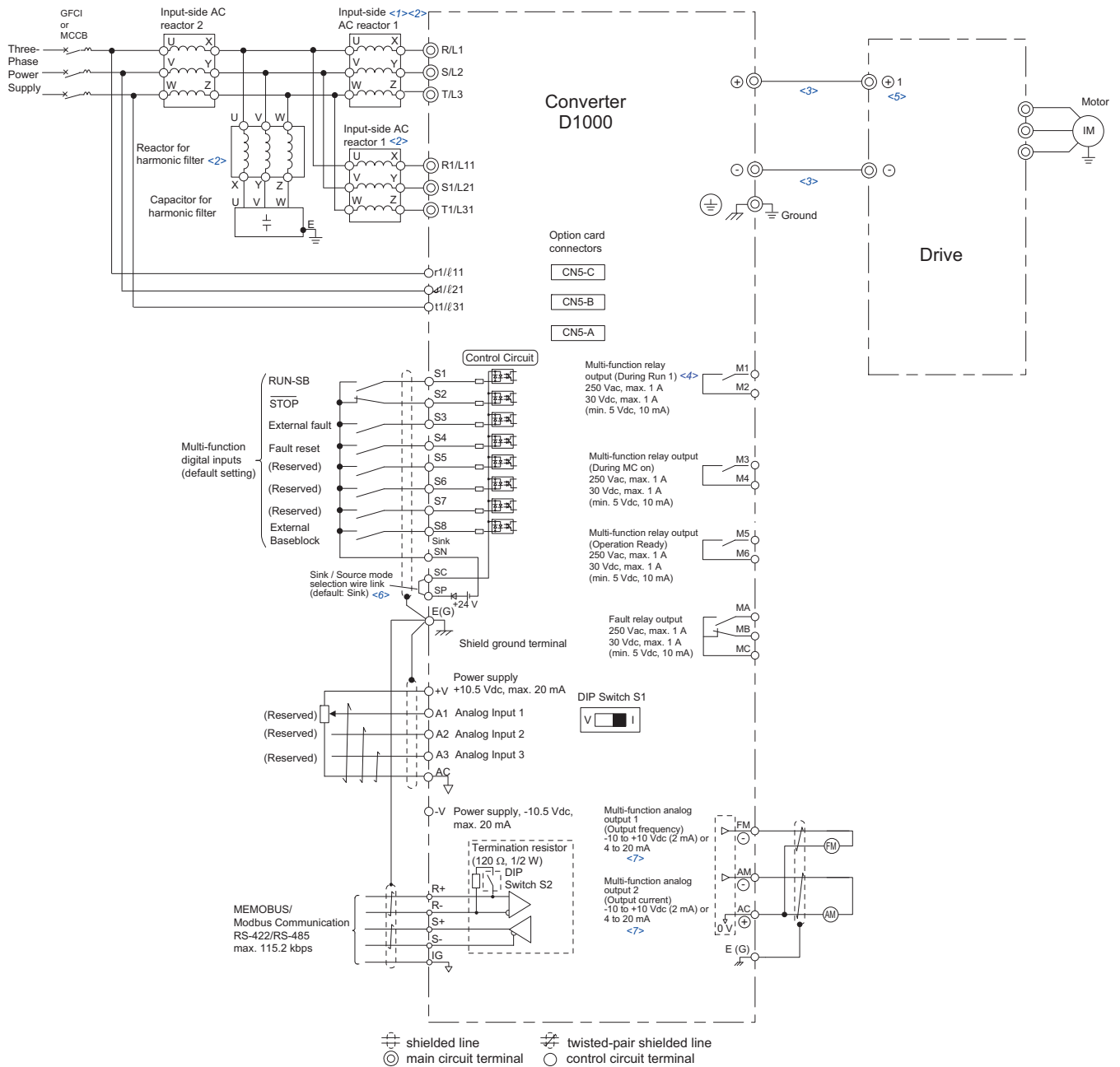

Figure 3.2 Standard Connection Diagram (example: model 4A0270, 4A0370)

- <1> Do not use a line longer than 10 m (32.8 ft) to connect the input-side AC reactor and the converter.
- <2> Use the specified AC reactor and harmonic filter module. Non-specified devices may cause erroneous operation.
- <3> Do not use a DC bus line that is longer than 5 m (16.4 ft) to connect the converter and drive.
- <4> Sequence the operation so that the converter starts operation before the drive when power is applied. Sequence the stopping operation to turn off the drive first, then the motor, and finally the converter. Operating the drive without operating the converter or turning off the power supply unit during operation may trigger a converter fault.
- <5> Do not connect a power supply to the drive AC power supply terminals (R/L1, S/L2, and T/L3).
- <6> The connections are shown for sequence connections with no-voltage contacts or NPN transistors for the sequence input signals (S1 to S8). Use jumper S3 to select between Sink mode and Source mode. The default setting is Sink mode.
- <7> Multi-function analog outputs work with devices such as analog frequency meters, ammeters, voltmeters, and wattmeters. They are not intended for use as a feedback-type signal.



**Figure 3.3 Standard Connection Diagram (example: model 4A0630)**

- <1> Do not use a line longer than 10 m (32.8 ft) to connect the input-side AC reactor and the converter.
- <2> Use the specified AC reactor and harmonic filter module. Non-specified devices may cause erroneous operation.
- <3> Do not use a DC bus line that is longer than 5 m (16.4 ft) to connect the converter and drive.
- <4> Sequence the operation so that the converter starts operation before the drive when power is applied. Sequence the stopping operation to turn off the drive first, then the motor, and finally the converter. Operating the drive without operating the converter or turning off the power supply unit during operation may trigger a converter fault.
- <5> Do not connect a power supply to the drive AC power supply terminals (R/L1, S/L2, and T/L3).
- <6> The connections are shown for sequence connections with no-voltage contacts or NPN transistors for the sequence input signals (S1 to S8). Use jumper S3 to select between Sink mode and Source mode. The default setting is Sink mode.
- <7> Multi-function analog outputs work with devices such as analog frequency meters, ammeters, voltmeters, and wattmeters. They are not intended for use as a feedback-type signal.

### 3.3 Main Circuit Connection Diagram

## 3.3 Main Circuit Connection Diagram

Refer to diagrams in this section when wiring the main circuit of the converter. Connections may vary based on converter capacity. The DC power supply for the main circuit also provides power to the control circuit.

**NOTICE:** Do not use the negative DC bus terminal “⊖” as a ground terminal. This terminal is at high DC voltage potential. Improper wiring connections could damage the converter.

#### ◆ CIMR-D□2A0005 to 2A0020, 4A0005 to 4A0020

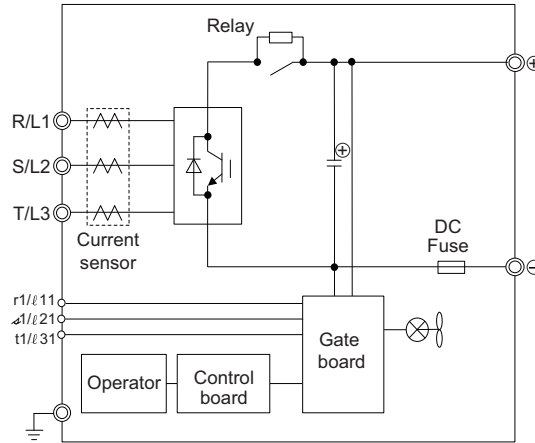

Figure 3.4 Connecting Main Circuit Terminals

#### ◆ CIMR-D□2A0030, 2A0050, 4A0030, 4A0040, 4A0060

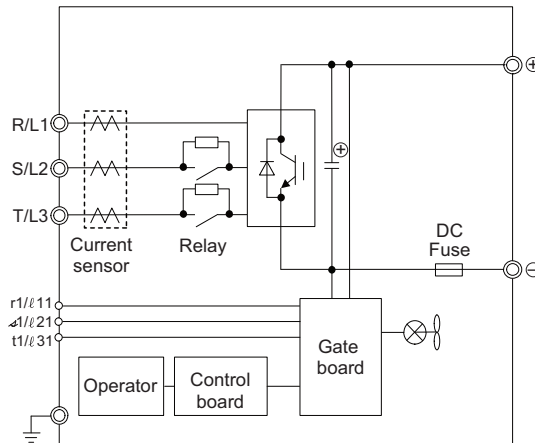

Figure 3.5 Connecting Main Circuit Terminals

◆ CIMR-D□2A0065, 2A0090, 2A0130, 4A0100, 4A0130, 4A0185

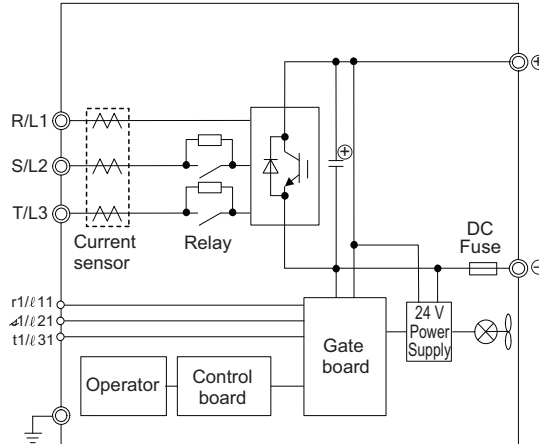

Figure 3.6 Connecting Main Circuit Terminals

◆ CIMR-D□4A0270, 4A0370

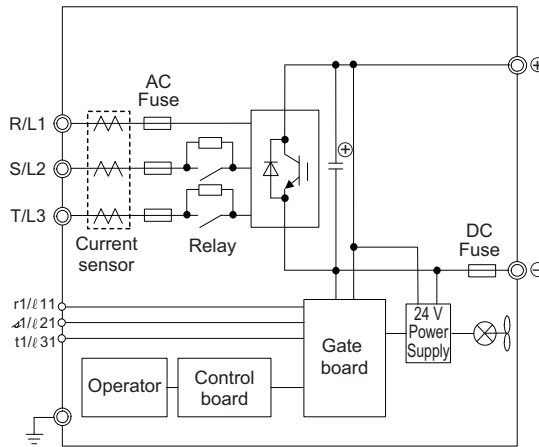

Figure 3.7 Connecting Main Circuit Terminals

◆ CIMR-D□4A0630

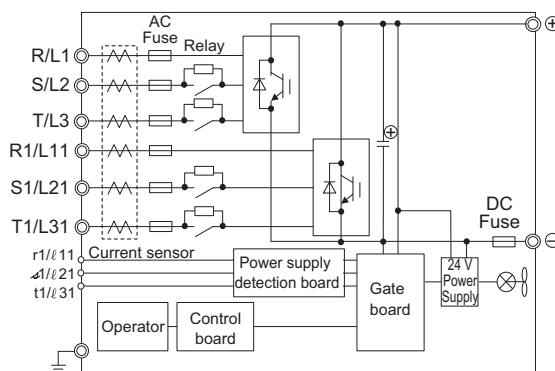

Figure 3.8 Connecting Main Circuit Terminals

## 3.4 Terminal Block Configuration

Refer to the terminal block configuration diagrams in [Table 3.1](#) for the location of the main circuit terminal block.

**Table 3.1 Terminal Block Configuration**

Model	Figure	
<b>200 V Class Models</b>	2A0005	<i>Figure 3.9</i>
	2A0010	<i>Figure 3.9</i>
	2A0020	<i>Figure 3.10</i>
	2A0030	<i>Figure 3.11</i>
	2A0050	<i>Figure 3.12</i>
	2A0065	<i>Figure 3.13</i>
	2A0090	<i>Figure 3.13</i>
	2A0130	<i>Figure 3.14</i>
<b>400 V Class Models</b>	4A0005	<i>Figure 3.9</i>
	4A0010	<i>Figure 3.9</i>
	4A0020	<i>Figure 3.10</i>
	4A0030	<i>Figure 3.11</i>
	4A0040	<i>Figure 3.11</i>
	4A0060	<i>Figure 3.12</i>
	4A0100	<i>Figure 3.12</i>
	4A0130	<i>Figure 3.14</i>
	4A0185	<i>Figure 3.14</i>
	4A0270	<i>Figure 3.15</i>
	4A0370	<i>Figure 3.15</i>
4A0630	<i>Figure 3.16</i>	

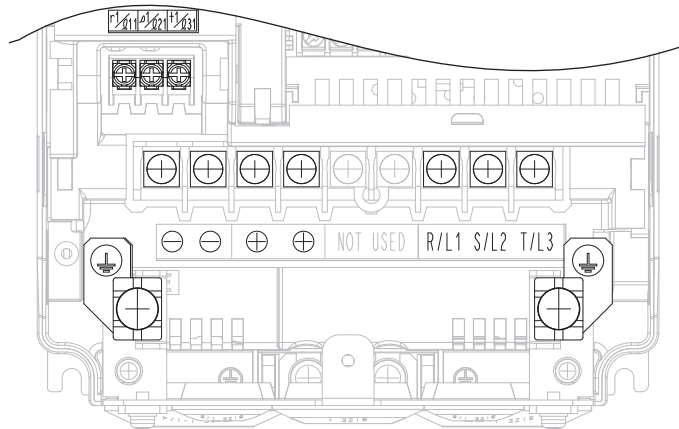

**Figure 3.9 Main Circuit Terminal Block Configuration (Models 2A0005, 2A0010, 4A0005, 4A0010)**

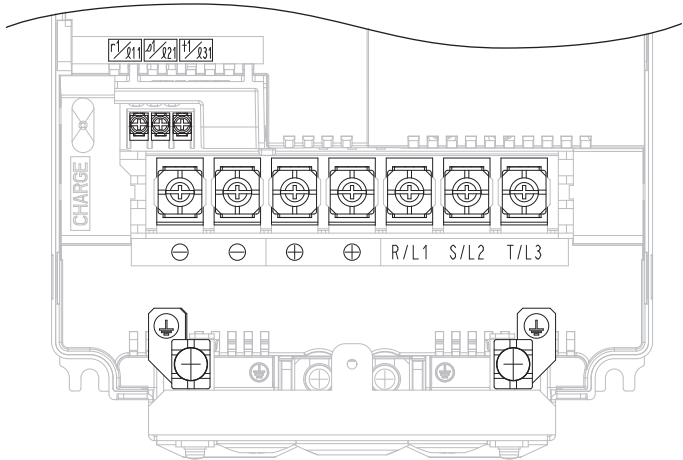

Figure 3.10 Main Circuit Terminal Block Configuration (Models 2A0020, 4A0020)

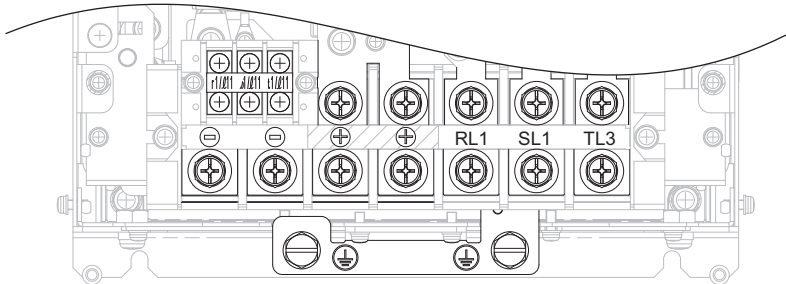

Figure 3.11 Main Circuit Terminal Block Configuration (Models 2A0030, 4A0030, 4A0040)

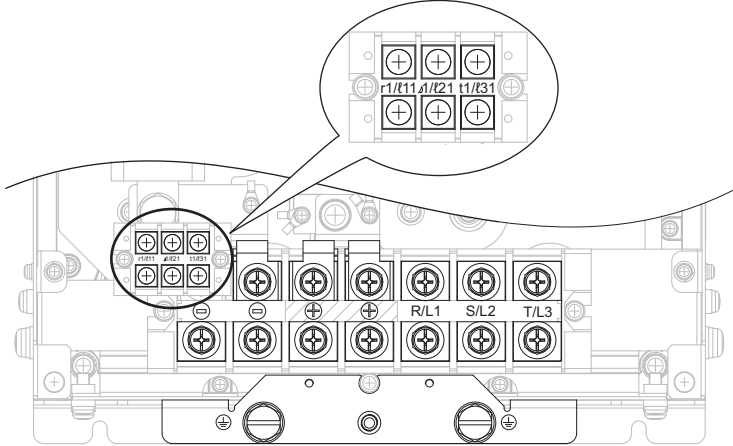

Figure 3.12 Main Circuit Terminal Block Configuration (Models 2A0050, 4A0060, 4A0100)

### 3.4 Terminal Block Configuration

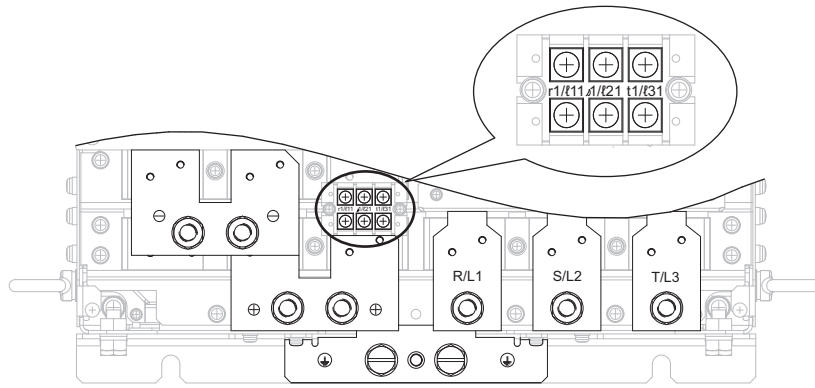

Figure 3.13 Main Circuit Terminal Block Configuration (Models 2A0065, 2A0090)

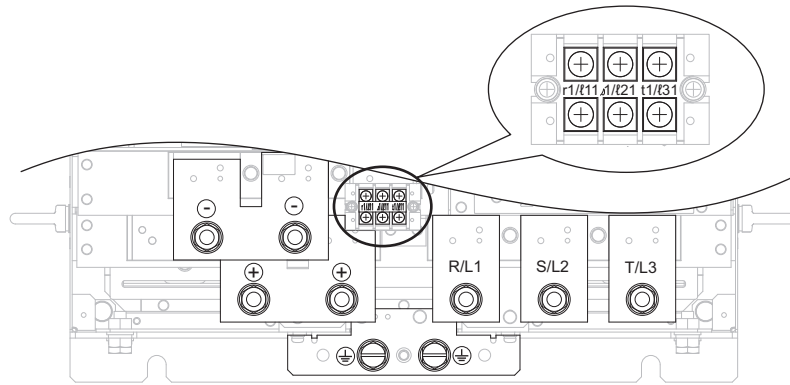

Figure 3.14 Main Circuit Terminal Block Configuration (Models 2A0130, 4A0130 to 4A0185)

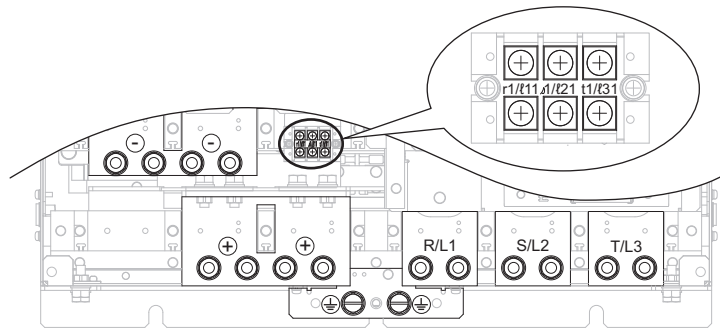

Figure 3.15 Main Circuit Terminal Block Configuration (Models 4A0270, 4A0370)

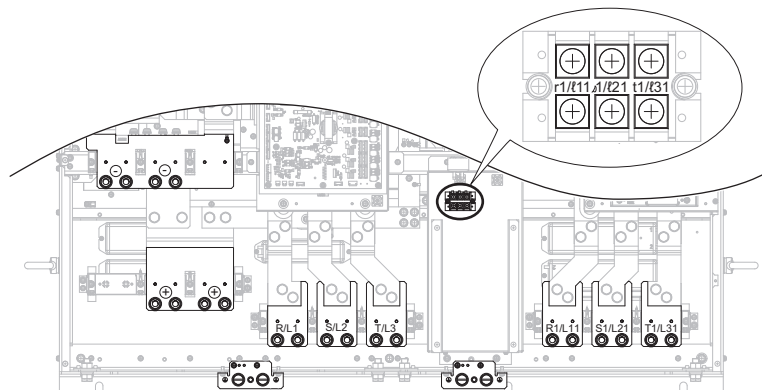

Figure 3.16 Main Circuit Terminal Block Configuration (Models 4A0630)



## 3.5 Terminal Cover

Follow the procedure below to remove the terminal cover for wiring and to reattach the terminal cover after wiring is complete.

### ◆ Models 2A0005 to 2A0020, 4A0005 to 4A0020 (IP20/Open Type Enclosure)

#### ■ Removing the Terminal Cover

Loosen the terminal cover screw using a #2 Phillips screwdriver. Screw sizes vary by converter model. Then, push in on the tab located on the bottom of the terminal cover and gently pull forward to remove the terminal cover.

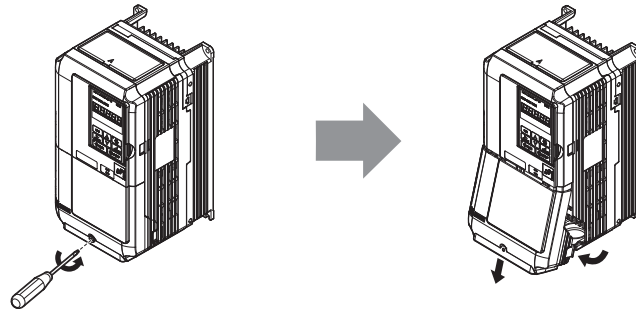
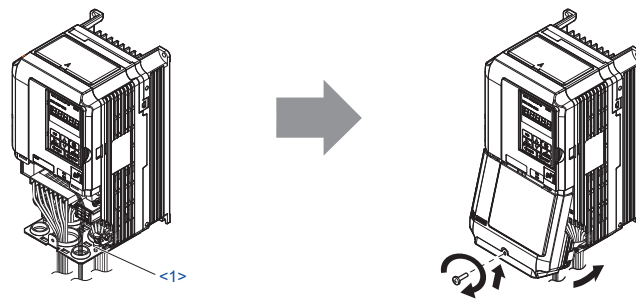

Figure 3.17 Removing the Terminal Cover on an IP20/Open Type Enclosure Model

#### ■ Reattaching the Terminal Cover

Power lines and signal wiring should pass through the opening provided. Refer to *Wiring the Main Circuit Terminal on page 66* and *Wiring the Control Circuit Terminal on page 79* for details on wiring.

Reattach the terminal cover after completing the wiring to the converter and other devices.



<1> Connect ground wiring first, followed by the main circuit, and then wire the control circuit. Power lines and signal wiring exit through the opening provided.

Figure 3.18 Reattaching the Terminal Cover on an IP20/Open Type Enclosure Model

### ◆ Models 2A0030 to 2A0130, 4A0030 to 4A0370 (IP00/Open Type enclosure)

#### ■ Removing the Terminal Cover

1. Loosen the screws on the terminal cover, then pull forward on the terminal cover to free it from the converter.

**Note:** Models 2A0065 to 2A0130 and 4A0130 to 4A0630 have three mounting screws above the terminal cover.

**CAUTION!** Do not completely remove the cover screws, just loosen them. If the cover screws are removed completely, the terminal cover may fall off causing an injury.

Larger capacity converters have large and heavy terminal covers. Remove and attach these covers with care.

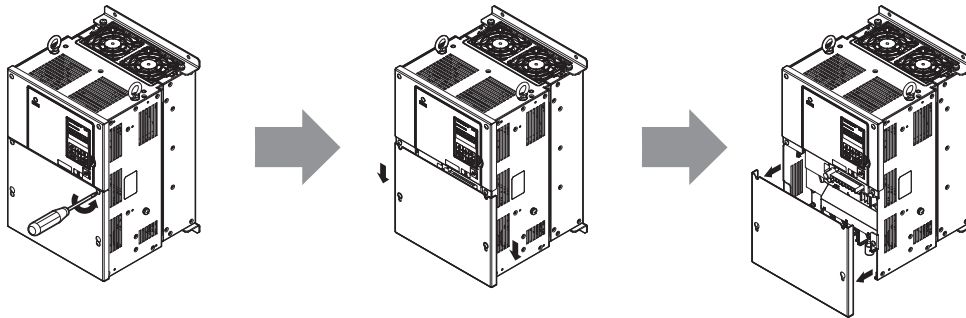
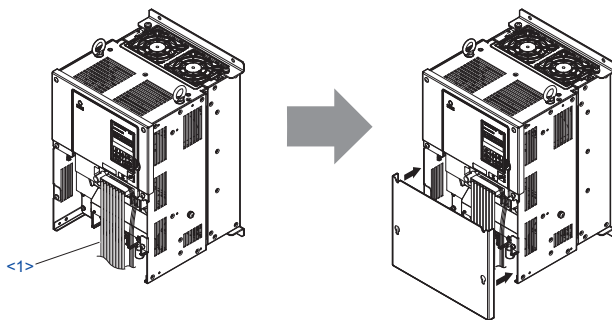

Figure 3.19 Removing the Terminal Cover on an IP00/Open Type enclosure Model

#### ■ Reattaching the Terminal Cover

After wiring the terminal board and other devices, double-check connections and reattach the terminal cover. Refer to [Wiring the Main Circuit Terminal on page 66](#) and [Wiring the Control Circuit Terminal on page 79](#) for details on wiring.



- <1> Connect ground wiring first, followed by the main circuit, and then wire the control circuit. Power lines and signal wiring exit through the opening provided.

Figure 3.20 Reattaching the Terminal Cover on an IP00/Open Type enclosure Model

## 3.6 Digital Operator and Front Cover

**NOTICE:** Be sure to remove the digital operator prior to opening or reattaching the front cover. Leaving the digital operator plugged into the converter when removing the front cover can result in erroneous operation caused by a poor connection. Firmly fasten the front cover back into place before reattaching the digital operator.

Detach the digital operator from the converter for remote operation or when opening the front cover to install an option card.

### ◆ Removing/Reattaching the Digital Operator

While pressing on the tab located on the right side of the digital operator, pull the digital operator forward to remove it from the converter.

Insert the digital operator into the opening in the top cover while aligning it with the notches on the left side of the opening. Next, press gently on the right side of the operator until it clicks into place.

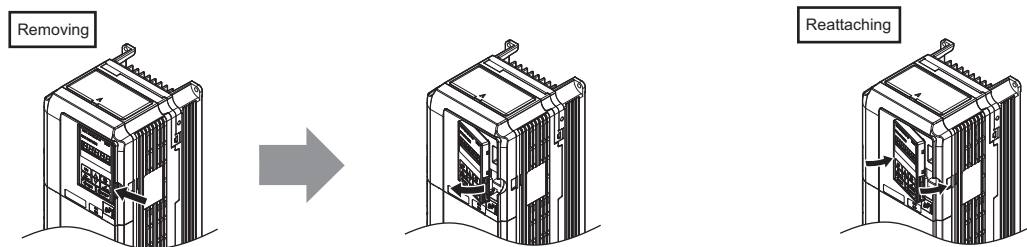

Figure 3.21 Removing/Reattaching the Digital Operator

### ◆ Removing/Reattaching the Front Cover

#### ■ Removing the Front Cover

##### Models 2A0005 to 2A0020 and 4A0005 to 4A0020

After removing the terminal cover and the digital operator, loosen the screw that affixes the front cover (models 2A0005 to 2A0020, 4A0005 to 4A0040 do not use a screw to affix the front cover). Pinch in on the tabs found on each side of the front cover, then pull forward to remove it from the converter.

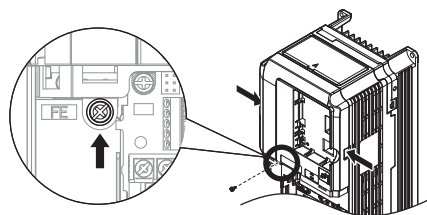
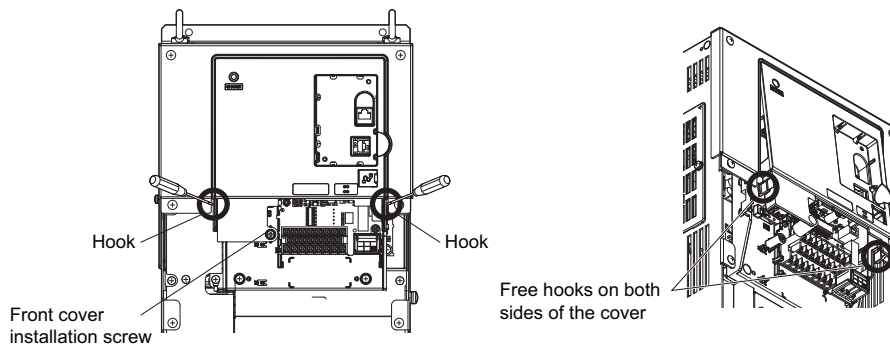

Figure 3.22 Remove the Front Cover (2A0005 to 2A0020 and 4A0005 to 4A0020)

## 3.6 Digital Operator and Front Cover

### Models 2A0030 to 2A0130, and 4A0030 to 4A0370

1. Remove the terminal cover and the digital operator.
2. Loosen the installation screw on the front cover.
3. Use a straight-edge screwdriver to loosen the hooks on each side of the cover that hold it in place.



**Figure 3.23 Remove the Front Cover (2A0030 to 2A0130, and 4A0030 to 4A0370)**

4. Unhook the left side of the front cover then swing the left side towards you as shown in [Figure 3.21](#) until the cover comes off.

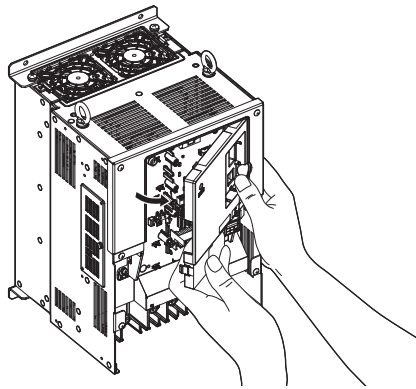

**Figure 3.24 Remove the Front Cover (2A0030 to 2A0130, and 4A0030 to 4A0370)**

### ■ Reattaching the Front Cover

#### Models 2A0005 to 2A0020 and 4A0005 to 4A0020

Reverse the instructions given in [Models 2A0005 to 2A0020, 4A0005 to 4A0020 \(IP20/Open Type Enclosure\) on page 57](#) to reattach the front cover. Pinch inwards on the hooks found on each side of the front cover while guiding it back into the converter. Make sure it clicks firmly into place.

#### Models 2A0030 to 2A0130 and 4A0030 to 4A0370

1. Slide the front cover so the hooks on the top connect to the converter.

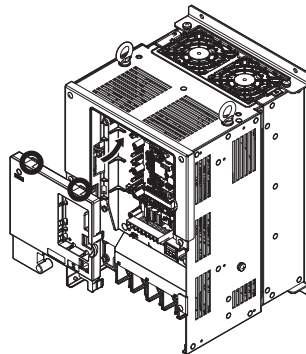

**Figure 3.25 Reattach the Front Cover (2A0030 to 2A0130, and 4A0030 to 4A0370)**

2. After connecting the hooks to the converter, press firmly on the cover to lock it into place.

## 3.7 Main Circuit Wiring

This section describes the functions, specifications, and procedures required to safely and properly wire the main circuit in the converter.

**NOTICE:** Do not switch the converter input power supply on and off frequently. Frequently switching the converter on and off shortens the life of the DC bus capacitors, and can cause premature unit failure. For the full performance life, refrain from switching the converter on and off more than once every 30 minutes.

**NOTICE:** Do not solder the ends of wire connections to the converter. Soldered wiring connections can loosen over time. Improper wiring practices could result in converter malfunction due to loose terminal connections.

### ◆ Main Circuit Terminal Functions

Table 3.2 Main Circuit Terminal Functions

Terminal	Type	Function	Page
200 V Class	2A0005 to 2A0130	These are the power supply input terminals that connect to the input reactor.	48
400 V Class	4A0005 to 4A0630		
Model			
R/L1	Main circuit power supply input	These are the power supply input terminals that connect to the input reactor.	48
S/L2			
T/L3			
r1/ℓ11	Power supply voltage detection inputs	These terminals are to detect the power supply voltage order and voltage levels.	48
u1/ℓ21			
t1/ℓ31			
⊖	DC voltage output	These terminals output a DC voltage	—
⊕			
⊕	For 200 V class: 100 Ω or less For 400 V class: 10 Ω or less	Grounding terminal	66

### ◆ Protecting Main Circuit Terminals

#### ■ Insulation Caps or Sleeves

Use insulation caps or sleeves when wiring the converter with crimp terminals. Take particular care to ensure that the wiring does not touch nearby terminals or the surrounding case.

#### ■ Insulation Barrier

Insulation barriers are packaged with models 4A0270 to 4A0630 to provide added protection between terminals.

Yaskawa recommends using the provided insulation barriers to ensure proper wiring. Refer to [Figure 3.26](#) and [Figure 3.27](#) for instructions on placement of the insulation barriers.

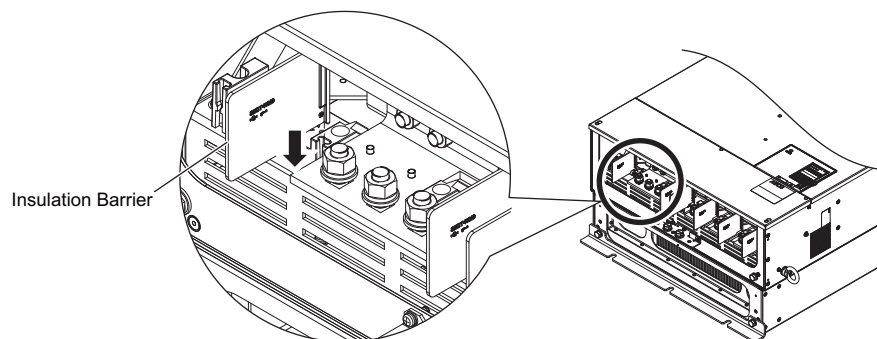

Figure 3.26 Installing Insulation Barriers

### 3.7 Main Circuit Wiring

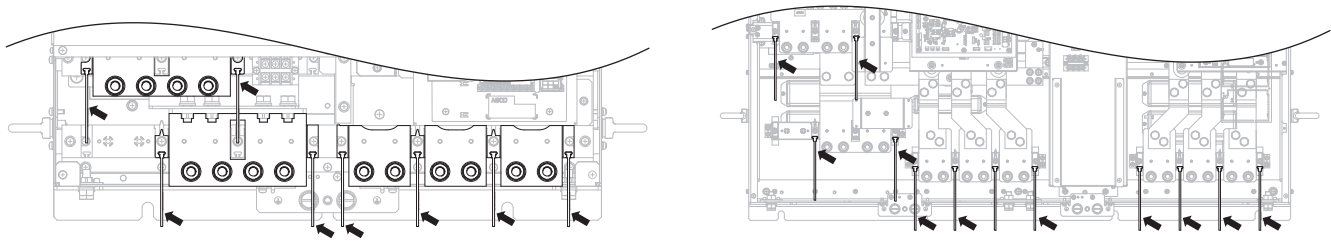

Figure 3.27 Locations of the Insulation Barriers

#### ◆ Wire Gauges and Tightening Torque

Use the tables in this section to select the appropriate wires and crimp terminals.

- Note:**
1. Wire gauge recommendations based on continuous current ratings using 75°C 600 Vac vinyl-sheathed wire assuming ambient temperature within 40°C.
  2. Wire gauge recommendations for terminals R/L1, S/L2, T/L3 on 4A0270 to 4A0630 based on continuous current ratings using 105°C 600 Vac vinyl-sheathed wire assuming ambient temperature within 40°C.
  3. Use terminals ⊕ and ⊖ when connecting the drive to the converter.

Consider the amount of voltage drop when selecting wire gauges. Increase the wire gauge when the voltage drop is greater than 2% of motor rated voltage. Ensure the wire gauge is suitable for the terminal block. Use the following formula to calculate the amount of voltage drop:

$$\text{Line drop voltage (V)} = \sqrt{3} \times \text{wire resistance } (\Omega/\text{km}) \times \text{wire length (m)} \times \text{current (A)} \times 10^{-3}$$

Refer to [UL Standards Compliance on page 247](#) for information on UL compliance.

The wire gauges listed in [Table 3.3](#) and [Table 3.4](#) are Yaskawa recommendations. Refer to local codes for proper wire gauge selections.

#### ■ Three-Phase 200 V Class

Table 3.3 Wire Gauge and Torque Specifications (Three-Phase 200 V Class)

Model	Terminal	For Asia <1>		For U.S.A. <2>		For Europe and China <3>		Screw Size	Tightening Torque N·m (lb·in.)
		Recomm. Gauge mm <sup>2</sup>	Applicable Gauge mm <sup>2</sup>	Recomm. Gauge AWG	Applicable Gauge AWG	Recomm. Gauge mm <sup>2</sup>	Applicable Gauge mm <sup>2</sup>		
2A0005	R/L1,S/L2,T/L3	2	2 to 14	12	12 to 6	4	4 to 16	M4	2.1 to 2.3 (18.6 to 20.4)
	⊖, ⊕	3.5	3.5 to 14	12	12 to 6	4	4 to 16	M4	2.1 to 2.3 (18.6 to 20.4)
	r1/ℓ11, s1/ℓ21, t1/ℓ31	2	2	14	14	2.5	2.5	M3.5	0.8 to 1.0 (7.1 to 8.9)
	⊕	3.5	1.5 to 5.5	10	16 to 10	1.5	1.5 to 6	M6	5.4 to 6.0 (47.8 to 53.1)
2A0010	R/L1,S/L2,T/L3	5.5	5.5 to 14	8	8 to 6	4	4 to 16	M4	2.1 to 2.3 (18.6 to 20.4)
	⊖, ⊕	14	14	8	8 to 6	6	4 to 16	M4	2.1 to 2.3 (18.6 to 20.4)
	r1/ℓ11, s1/ℓ21, t1/ℓ31	2	2	14	14	2.5	2.5	M3.5	0.8 to 1.0 (7.1 to 8.9)
	⊕	3.5	3.5 to 5.5	10	12 to 10	4	4 to 6	M6	5.4 to 6.0 (47.8 to 53.1)

Model	Terminal	For Asia <1>		For U.S.A. <2>		For Europe and China <3>		Screw Size	Tightening Torque N·m (lb·in.)
		Recomm. Gauge mm <sup>2</sup>	Applicable Gauge mm <sup>2</sup>	Recomm. Gauge AWG	Applicable Gauge AWG	Recomm. Gauge mm <sup>2</sup>	Applicable Gauge mm <sup>2</sup>		
2A0020	R/L1,S/L2,T/L3	14	14 to 38	4	4 to 1	16	16 to 35	M6	3.6 to 4.0 (31.9 to 35.4)
	⊖, ⊕	22	22 to 38	4	4 to 1	16	16 to 35	M6	3.6 to 4.0 (31.9 to 35.4)
	r1/ℓ11,ℓ1/ℓ21,t1/ℓ31	2	2	14	14	2.5	2.5	M3.5	0.8 to 1.0 (7.1 to 8.9)
	⊕	8	8 to 14	6	8 to 6	16	10 to 16	M6	5.4 to 6.0 (47.8 to 53.1)
2A0030	R/L1,S/L2,T/L3	38	38 to 70	2	2 to 2/0	25	25 to 70	M8	5.4 to 6.0 (47.8 to 53.1)
	⊖, ⊕	38	38 to 70	2	2 to 2/0	25	25 to 70	M8	5.4 to 6.0 (47.8 to 53.1)
	r1/ℓ11,ℓ1/ℓ21,t1/ℓ31	2	2 to 5.5	14	14 to 10	2.5	2.5 to 6	M4	1.1 to 1.2 (9.7 to 10.6)
	⊕	22	14 to 22	4	6 to 4	16	16 to 25	M8	9.0 to 11.0 (79.7 to 97.4)
2A0050	R/L1,S/L2,T/L3	60	60 to 70	3 × 2P	3 to 2/0	50	50 to 70	M8	5.4 to 6.0 (47.8 to 53.1)
	⊖, ⊕	60 × 2P	60 to 70	1/0 × 2P	1/0 to 2/0	70	70	M8	5.4 to 6.0 (47.8 to 53.1)
	r1/ℓ11,ℓ1/ℓ21,t1/ℓ31	2	2 to 5.5	14	14 to 10	2.5	2.5 to 6	M4	1.1 to 1.2 (9.7 to 10.6)
	⊕	22	22	4	4	25	25	M10	18 to 23 (159 to 204)
2A0065	R/L1,S/L2,T/L3	80 × 2P	80 to 150	3/0 × 2P	3/0 to 300	95	95 to 150	M12	32 to 40 (283 to 354)
	⊖, ⊕	100	100 to 150	3/0 × 2P	3/0 to 300	95	95 to 150	M12	32 to 40 (283 to 354)
	r1/ℓ11,ℓ1/ℓ21,t1/ℓ31	2	2 to 5.5	14	14 to 10	2.5	2.5 to 6	M4	1.1 to 1.2 (9.7 to 10.6)
	⊕	38	38 to 50	1	1 to 1/0	50	35 to 50	M12	32 to 40 (283 to 354)
2A0090	R/L1,S/L2,T/L3	80 × 2P	80 to 150	3/0 × 2P	3/0 to 300	95 × 2P	95 to 150	M12	32 to 40 (283 to 354)
	⊖, ⊕	80 × 2P	80 to 150	3/0 × 2P	3/0 to 300	150	150	M12	32 to 40 (283 to 354)
	r1/ℓ11,ℓ1/ℓ21,t1/ℓ31	2	2 to 5.5	14	14 to 10	2.5	2.5 to 6	M4	1.1 to 1.2 (9.7 to 10.6)
	⊕	60	60 to 100	1/0	1/0 to 4/0	95	70 to 95	M12	32 to 40 (283 to 354)
2A0130	R/L1,S/L2,T/L3	100 × 2P	100 to 325	300 × 2P	300 to 600	95 × 2P	95 to 300	M12	32 to 40 (283 to 354)
	⊖, ⊕	150 × 2P	150 to 325	300 × 2P	300 to 600	240	240 to 300	M12	32 to 40 (283 to 354)
	r1/ℓ11,ℓ1/ℓ21,t1/ℓ31	2	2 to 5.5	14	14 to 10	2.5	2.5 to 6	M4	1.1 to 1.2 (9.7 to 10.6)
	⊕	60	60 to 100	2/0	2/0 to 4/0	95	70 to 95	M12	32 to 40 (283 to 354)

<1> Gauges listed here are for use in Japan.  
 <2> Gauges listed here are for use in the United States.  
 <3> Gauges listed here are for use in Europe and China.

### 3.7 Main Circuit Wiring

Table 3.4 Three-Phase 400 V Class

Model	Terminal	For Asia <1>		For U.S.A. <2>		For Europe and China <3>		Screw Size	Tightening Torque N·m (lb·in.)
		Recomm. Gauge mm <sup>2</sup>	Applicable Gauge mm <sup>2</sup>	Recomm. Gauge AWG	Applicable Gauge AWG	Recomm. Gauge mm <sup>2</sup>	Applicable Gauge mm <sup>2</sup>		
4A0005	R/L1,S/L2,T/L3	1.25	1.25 to 14	12	12 to 6	4	4 to 16	M4	2.1 to 2.3 (18.6 to 20.4)
	⊖, ⊕	3.5	3.5 to 14	12	12 to 6	4	4 to 16	M4	2.1 to 2.3 (18.6 to 20.4)
	r1/ℓ11, ⓐ1/ℓ21,t1/ℓ31	2	2	14	14	2.5	2.5	M3.5	0.8 to 1.0 (7.1 to 8.9)
	⊕	2	2 to 3.5	12	14 to 12	0.75	0.75 to 4	M6	5.4 to 6.0 (47.8 to 53.1)
4A0010	R/L1,S/L2,T/L3	2	2 to 14	12	12 to 6	4	2.5 to 16	M4	2.1 to 2.3 (18.6 to 20.4)
	⊖, ⊕	3.5	3.5 to 14	12	12 to 6	4	4 to 16	M4	2.1 to 2.3 (18.6 to 20.4)
	r1/ℓ11, ⓐ1/ℓ21,t1/ℓ31	2	2	14	14	2.5	2.5	M3.5	0.8 to 1.0 (7.1 to 8.9)
	⊕	3.5	3.5 to 5.5	10	12 to 10	2.5	2.5 to 6	M6	5.4 to 6 (47.8 to 53.1)
4A0020	R/L1,S/L2,T/L3	8	8 to 38	8	8 to 1	6	6 to 35	M6	3.6 to 4.0 (31.9 to 35.4)
	⊖, ⊕	14	14 to 38	8	8 to 1	6	6 to 35	M6	3.6 to 4.0 (31.9 to 35.4)
	r1/ℓ11, ⓐ1/ℓ21,t1/ℓ31	2	2	14	14	2.5	2.5	M3.5	0.8 to 1.0 (7.1 to 8.9)
	⊕	5.5	5.5 to 8	8	10 to 8	6	6 to 10	M6	5.4 to 6.0 (47.8 to 53.1)
4A0030	R/L1,S/L2,T/L3	14	14 to 70	6	6 to 2/0	10	10 to 70	M8	5.4 to 6.0 (47.8 to 53.1)
	⊖, ⊕	14	14 to 70	6	6 to 2/0	10	10 to 70	M8	5.4 to 6.0 (47.8 to 53.1)
	r1/ℓ11, ⓐ1/ℓ21,t1/ℓ31	2	2 to 5.5	14	14 to 10	2.5	2.5 to 6	M4	1.1 to 1.2 (9.7 to 10.6)
	⊕	14	8 to 14	6	8 to 6	10	10 to 16	M8	9.0 to 11.0 (79.7 to 97.4)
4A0040	R/L1,S/L2,T/L3	14	14 to 70	4	4 to 2/0	16	16 to 70	M8	5.4 to 6.0 (47.8 to 53.1)
	⊖, ⊕	22	22 to 70	4	4 to 2/0	16	16 to 70	M8	5.4 to 6.0 (47.8 to 53.1)
	r1/ℓ11, ⓐ1/ℓ21,t1/ℓ31	2	2 to 5.5	14	14 to 10	2.5	2.5 to 6	M4	1.1 to 1.2 (9.7 to 10.6)
	⊕	14	14	6	6	16	16	M8	9.0 to 11.0 (79.7 to 97.4)
4A0060	R/L1,S/L2,T/L3	38	38 to 70	2	2 to 2/0	25	25 to 70	M8	5.4 to 6.0 (47.8 to 53.1)
	⊖, ⊕	38	38 to 70	2	2 to 2/0	25	25 to 70	M8	5.4 to 6.0 (47.8 to 53.1)
	r1/ℓ11, ⓐ1/ℓ21,t1/ℓ31	2	2 to 5.5	14	14 to 10	2.5	2.5 to 6	M4	1.1 to 1.2 (9.7 to 10.6)
	⊕	14	14	6	6	16	16	M10	18 to 23 (159 to 204)



Model	Terminal	For Asia <1>		For U.S.A. <2>		For Europe and China <3>		Screw Size	Tightening Torque N·m (lb·in.)
		Recomm. Gauge mm <sup>2</sup>	Applicable Gauge mm <sup>2</sup>	Recomm. Gauge AWG	Applicable Gauge AWG	Recomm. Gauge mm <sup>2</sup>	Applicable Gauge mm <sup>2</sup>		
4A0100	R/L1,S/L2,T/L3	60	60 to 70	3 × 2P	3 to 2/0	50	50 to 70	M8	5.4 to 6.0 (47.8 to 53.1)
	⊖, ⊕	60 × 2P	60 to 70	1/0 × 2P	1/0 to 2/0	70	70	M8	5.4 to 6.0 (47.8 to 53.1)
	r1/ℓ11,ℓ1/ℓ21,t1/ℓ31	2	2 to 5.5	14	14 to 10	2.5	2.5 to 6	M4	1.1 to 1.2 (9.7 to 10.6)
	⊕	22	22	3	3	25	25	M10	18 to 23 (159 to 204)
4A0130	R/L1,S/L2,T/L3	80 × 2P	80 to 325	3/0 × 2P	3/0 to 600	95	95 to 300	M10	18 to 23 (159 to 204)
	⊖, ⊕	100	100 to 325	3/0 × 2P	3/0 to 600	95	95 to 300	M10	18 to 23 (159 to 204)
	r1/ℓ11,ℓ1/ℓ21,t1/ℓ31	2	2 to 5.5	14	14 to 10	2.5	2.5 to 6	M4	1.1 to 1.2 (9.7 to 10.6)
	⊕	60	50 to 60	1/0	1/0 to 2/0	50	50 to 70	M10	18 to 23 (159 to 204)
4A0185	R/L1,S/L2,T/L3	80 × 2P	80 to 325	3/0 × 2P	3/0 to 600	95 × 2P	95 to 300	M12	32 to 40 (283 to 354)
	⊖, ⊕	200	200 to 325	3/0 × 2P	3/0 to 600	150	150 to 300	M12	32 to 40 (283 to 354)
	r1/ℓ11,ℓ1/ℓ21,t1/ℓ31	2	2 to 5.5	14	14 to 10	2.5	2.5 to 6	M4	1.1 to 1.2 (9.7 to 10.6)
	⊕	60	50 to 100	1/0	1/0 to 4/0	95	50 to 95	M12	32 to 40 (283 to 354)
4A0270	R/L1,S/L2,T/L3	60 × 2P	60 to 150	300 × 2P	300	95 × 2P	95 to 150	M12	32 to 40 (283 to 354)
	⊖, ⊕	100 × 2P	100 to 150	300 × 2P	300	95 × 2P	95 to 150	M12	32 to 40 (283 to 354)
	r1/ℓ11,ℓ1/ℓ21,t1/ℓ31	2	2 to 5.5	14	14 to 10	2.5	2.5 to 6	M4	1.1 to 1.2 (9.7 to 10.6)
	⊕	60	60 to 100	2/0	2/0 to 4/0	95	70 to 95	M12	32 to 40 (283 to 354)
4A0370	R/L1,S/L2,T/L3	100 × 2P	100 to 150	4/0 × 4P	4/0 to 300	150 × 2P	150	M12	32 to 40 (283 to 354)
	⊖, ⊕	100 × 4P	100 to 150	4/0 × 4P	4/0 to 300	150 × 2P	150	M12	32 to 40 (283 to 354)
	r1/ℓ11,ℓ1/ℓ21,t1/ℓ31	2	2 to 5.5	14	14 to 10	2.5	2.5 to 6	M4	1.1 to 1.2 (9.7 to 10.6)
	⊕	60 × 2P	60 to 150	4/0	2/0 to 300	150	70 to 150	M12	32 to 40 (283 to 354)
4A0630	R/L1,S/L2,T/L3	100 × 4P	100 to 150	4/0 × 8P	4/0 to 300	150 × 4P	150	M12	32 to 40 (283 to 354)
	⊖, ⊕	150 × 4P	150	4/0 × 8P	4/0 to 300	120 × 4P	120 to 150	M12	32 to 40 (283 to 354)
	r1/ℓ11,ℓ1/ℓ21,t1/ℓ31	2	2 to 5.5	14	14 to 10	2.5	2.5 to 6	M4	1.1 to 1.2 (9.7 to 10.6)
	⊕	60 × 2P	60 to 150	250	2/0 to 300	150 × 2P	70 to 150	M12	32 to 40 (283 to 354)

<1> Gauges listed here are for use in Japan.  
 <2> Gauges listed here are for use in the United States.  
 <3> Gauges listed here are for use in Europe and China.

## 3.7 Main Circuit Wiring

### ◆ Ground Wiring

Follow the precautions below when wiring the ground for one converter or a series of converters.

**WARNING! Electrical Shock Hazard.** Always use a ground wire that complies with technical standards on electrical equipment and minimize the length of the ground wire. Improper equipment grounding may cause dangerous electrical potentials on equipment chassis, which could result in death or serious injury.

**WARNING! Electrical Shock Hazard.** Be sure to ground the converter ground terminal (200 V class: ground to 100  $\Omega$  or less; 400 V class: ground to 10  $\Omega$  or less). Improper equipment grounding could result in death or serious injury by contacting ungrounded electrical equipment.

**NOTICE:** Do not share the ground wire with other devices such as welding machines or large-current electrical equipment. Improper equipment grounding could result in converter or equipment malfunction due to electrical interference.

**NOTICE:** When using more than one converter, ground multiple converters according to instructions. Improper equipment grounding could result in abnormal operation of converter or equipment.

**NOTICE:** If devices, such as office equipment, that is sensitive to noise are installed in the same location, separate the ground wires and use independent grounds or noise filters to prevent noise from entering the devices through the ground wire. Otherwise, the office equipment may fail.

**Note:** If other devices are installed in the same location, connect them while observing the grounding standards for each device. Otherwise the converters or the devices may fail to operate.

Refer to [Figure 3.28](#) when using a converter with multiple drives. Do not loop the ground wire.

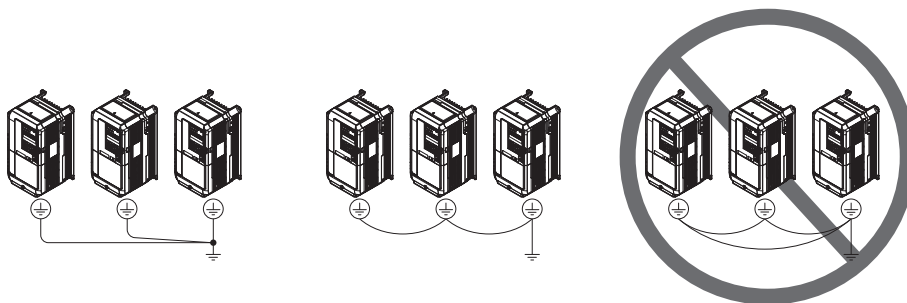

Figure 3.28 Installation Examples for a Converter and Several Drives

### ■ Wiring the Main Circuit Terminal

**WARNING! Electrical Shock Hazard.** Shut off the power supply to the converter before wiring the main circuit terminals. Failure to comply may result in death or serious injury.

Wire the main circuit terminals after the terminal board has been properly grounded.

### ■ Main Circuit Connection Diagram

Refer to [Main Circuit Connection Diagram on page 52](#) when wiring terminals on the main power circuit of the converter.

## 3.8 Harmonic Filter Module Wiring

This section describes the terminal functions, terminal specifications, and wiring methods to correctly and safely wire converters and harmonic filter modules.

**NOTICE:** To comply with the UL compliance, attach crimp terminals to the ends of the cables that connects to the harmonic filter module.

### ◆ Terminal Configuration

Refer to [Figure 3.29](#) for the terminal arrangements. Refer to [Wiring a Harmonic Filter Module on page 73](#) for the procedures to remove the faceplate and top cover.

EUJ71080□, EUJ71081□,  
EUJ71088□, EUJ71089□

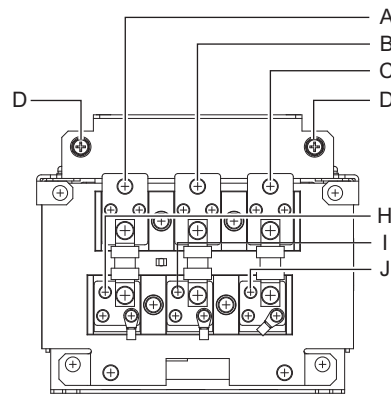

Front

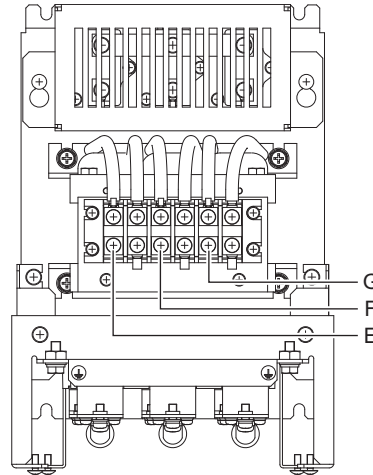

Top

EUJ71082□, EUJ71083□, EUJ71084□, EUJ71090□,  
EUJ71091□, EUJ71092□, EUJ71093□, EUJ71094□

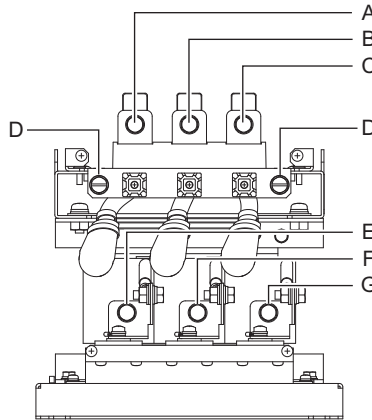

Front

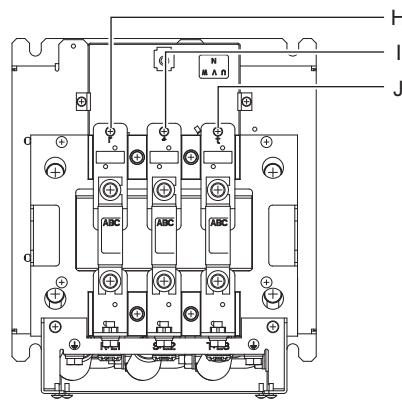

Top

### 3.8 Harmonic Filter Module Wiring

EUJ71085□, EUJ71086□

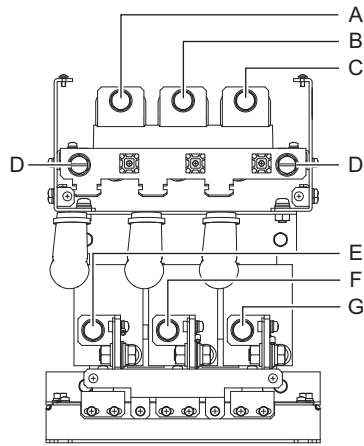

Front

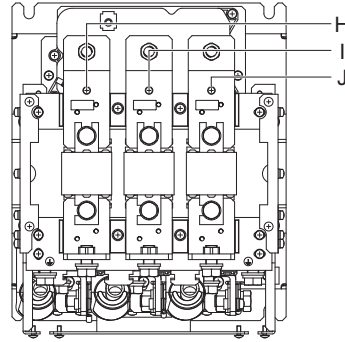

Top

EUJ71087□, EUJ71095□, EUJ71096□

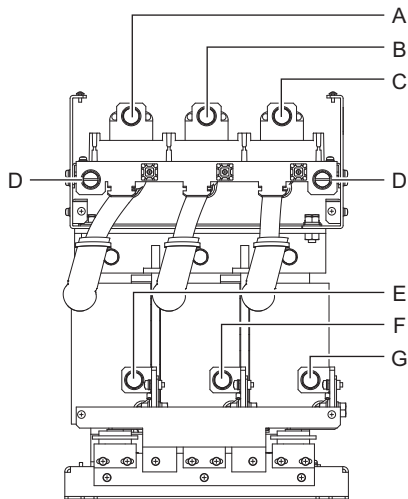

Front

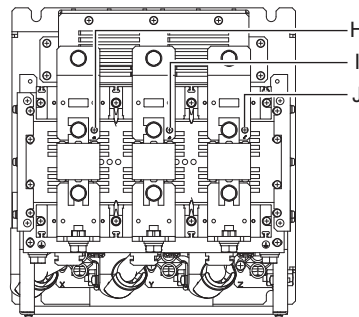

Top

A - R/L1  
 B - S/L2  
 C - T/L3  
 D - Ground Terminal  
 E - X

F - Y  
 G - Z  
 H - r  
 I -  $\sphericalangle$   
 J - t

Figure 3.29 Harmonic Filter Module Terminal Configuration

## ◆ Terminal Functions

Table 3.5 Terminal Functions

Terminal	Type	Function	Page
R/L1	Main circuit power supply inputs	These terminals are connected to the power supply.	48
S/L2			
T/L3			
r	Power supply voltage detection inputs	These terminals are to detect the power supply voltage order and voltage levels.	48
s			
t			
X	Harmonic filter module outputs	These terminals connect to the input-side AC reactor.	–
Y			
Z			
	For 200 V class: 100 Ω or less For 400 V class: 10 Ω or less	Grounding terminal	66

## ◆ Protecting Circuit Terminals

### ■ Insulation Caps or Sleeves

Use insulation caps or sleeves when wiring the module with crimp terminals. Take particular care to ensure that the wiring does not touch nearby terminals or the surrounding case.

## ◆ Wire Gauges and Tightening Torque

Use the tables in this section to select the appropriate wires and crimp terminals.

- Note:**
1. Wire gauge recommendations based on continuous current ratings using 75°C 600 Vac vinyl-sheathed wire assuming ambient temperature within 40°C.
  2. Wire gauge recommendations for models 4A0270 to 4A0630 based on continuous current ratings using 105°C 600 Vac vinyl-sheathed wire assuming ambient temperature within 40°C.

Consider the amount of voltage drop when selecting wire gauges. Increase the wire gauge when the voltage drop is greater than 2% of motor rated voltage. Ensure the wire gauge is suitable for the terminal block. Use the following formula to calculate the amount of voltage drop:

$$\text{Line drop voltage (V)} = \sqrt{3} \times \text{wire resistance } (\Omega/\text{km}) \times \text{wire length (m)} \times \text{current (A)} \times 10^{-3}$$

### 3.8 Harmonic Filter Module Wiring

#### ■ Three-Phase 200 V Class

Table 3.6 Wire Gauge and Torque Specifications (Three-Phase 200 V Class)

Model	Terminal	For Asia <1>		For U.S.A. <2>		For Europe and China <3>		Screw Size	Tightening Torque N·m (lb·in.)
		Recomm. Gauge mm <sup>2</sup>	Applicable Gauge mm <sup>2</sup>	Recomm. Gauge AWG	Applicable Gauge AWG	Recomm. Gauge mm <sup>2</sup>	Applicable Gauge mm <sup>2</sup>		
EUJ71080□	R/L1, S/L2, T/L3	2	2 to 8	12	12 to 8	4	4 to 10	M4	1.1 to 1.2 (9.7 to 10.6)
	X, Y, Z		2 to 3.5		12		4		1.1 to 1.2 (9.7 to 10.6)
	r, s, t	2	2	14	14	2.5	2.5	M4	1.1 to 1.2 (9.7 to 10.6)
	⊕	3.5	1.5 to 5.5	10	16 to 10	1.5	1.5 to 6	M5	2.2 to 2.4 (19.1 to 21.2)
EUJ71081□	R/L1, S/L2, T/L3	5.5	5.5 to 8	8	8	4	4 to 10	M5	2.2 to 2.4 (19.1 to 21.2)
	X, Y, Z		5.5 to 8		8		4 to 10		2.2 to 2.4 (19.1 to 21.2)
	r, s, t	2	2	14	14	2.5	2.5	M4	1.1 to 1.2 (9.7 to 10.6)
	⊕	3.5	3.5 to 5.5	10	12 to 10	4	4 to 6	M5	2.2 to 2.4 (19.1 to 21.2)
EUJ71082□	R/L1, S/L2, T/L3	14	14 to 80	4	4 to 3/0	16	16 to 70	M6	4.0 to 4.9 (35.4 to 43.4)
	X, Y, Z		14 to 22		4		16 to 25		4.0 to 4.9 (35.4 to 43.4)
	r, s, t	2	2	14	14	2.5	2.5	M4	1.1 to 1.2 (9.7 to 10.6)
	⊕	8	8 to 14	6	8 to 6	16	10 to 16	M6	4.0 to 4.9 (35.4 to 43.4)
EUJ71083□	R/L1, S/L2, T/L3	38	38 to 80	2	2 to 3/0	25	25 to 70	M8	8.9 to 10.7 (79.7 to 97.4)
	X, Y, Z		38		2 to 1		25 to 35		8.9 to 10.7 (79.7 to 97.4)
	r, s, t	2	2 to 5.5	14	14 to 10	2.5	2.5 to 6	M4	1.1 to 1.2 (9.7 to 10.6)
	⊕	22	14 to 22	4	6 to 4	16	16 to 25	M8	8.9 to 10.7 (79.7 to 97.4)
EUJ71084□	R/L1, S/L2, T/L3	60	60 to 80	3 × 2P	3 to 3/0	50	50 to 70	M8	8.9 to 10.7 (79.7 to 97.4)
	X, Y, Z		60 to 80		3 to 3/0		50 to 70		8.9 to 10.7 (79.7 to 97.4)
	r, s, t	2	2 to 5.5	14	14 to 10	2.5	2.5 to 6	M4	1.1 to 1.2 (9.7 to 10.6)
	⊕	22	22	4	4	25	25	M8	8.9 to 10.7 (79.7 to 97.4)
EUJ71085□	R/L1, S/L2, T/L3	80 × 2P	80 to 150	3/0 × 2P	3/0 to 300	95	95 to 150	M12	32 to 40 (283 to 354)
	X, Y, Z		80		3/0		95		32 to 40 (283 to 354)
	r, s, t	2	2 to 5.5	14	14 to 10	2.5	2.5 to 6	M4	1.1 to 1.2 (9.7 to 10.6)
	⊕	38	38 to 50	1	1 to 1/0	50	35 to 50	M12	32 to 40 (283 to 354)

Model	Terminal	For Asia <1>		For U.S.A. <2>		For Europe and China <3>		Screw Size	Tightening Torque N·m (lb·in.)
		Recomm. Gauge mm <sup>2</sup>	Applicable Gauge mm <sup>2</sup>	Recomm. Gauge AWG	Applicable Gauge AWG	Recomm. Gauge mm <sup>2</sup>	Applicable Gauge mm <sup>2</sup>		
EUJ71086□	R/L1, S/L2, T/L3	80 × 2P	80 to 150	3/0 × 2P	3/0 to 300	95 × 2P	95 to 150	M12	32 to 40 (283 to 354)
	X, Y, Z		80		3/0		95		32 to 40 (283 to 354)
	r, s, t	2	2 to 5.5	14	14 to 10	2.5	2.5 to 6	M4	1.1 to 1.2 (9.7 to 10.6)
	⊕	60	60 to 100	1/0	1/0 to 4/0	95	70 to 95	M12	32 to 40 (283 to 354)
EUJ71087□	R/L1, S/L2, T/L3	100 × 2P	100 to 150	300 × 2P	300	95 × 2P	95 to 150	M12	32 to 40 (283 to 354)
	X, Y, Z		100 to 150		300		95 to 150		32 to 40 (283 to 354)
	r, s, t	2	2 to 5.5	14	14 to 10	2.5	2.5 to 6	M4	1.1 to 1.2 (9.7 to 10.6)
	⊕	60	60 to 100	2/0	2/0 to 4/0	95	70 to 95	M12	32 to 40 (283 to 354)

<1> Gauges listed here are for use in Japan.  
 <2> Gauges listed here are for use in the United States.  
 <3> Gauges listed here are for use in Europe and China.

■ Three-Phase 400 V Class

Table 3.7 Wire Gauge and Torque Specifications (Three-Phase 400 V Class)

Model	Terminal	For Asia <1>		For U.S.A. <2>		For Europe and China <3>		Screw Size	Tightening Torque N·m (lb·in.)
		Recomm. Gauge mm <sup>2</sup>	Applicable Gauge mm <sup>2</sup>	Recomm. Gauge AWG	Applicable Gauge AWG	Recomm. Gauge mm <sup>2</sup>	Applicable Gauge mm <sup>2</sup>		
EUJ71088□	R/L1, S/L2, T/L3	1.25	1.25 to 8	12	12 to 8	4	4 to 10	M4	1.1 to 1.2 (9.7 to 10.6)
	X, Y, Z		1.25 to 3.5		12		4		1.1 to 1.2 (9.7 to 10.6)
	r, s, t	2	2	14	14	2.5	2.5	M4	1.1 to 1.2 (9.7 to 10.6)
	⊕	2	2 to 3.5	12	14 to 12	0.75	0.75 to 4	M5	2.2 to 2.4 (19.1 to 21.2)
EUJ71089□	R/L1, S/L2, T/L3	2	2 to 8	12	12 to 8	4	4 to 10	M4	1.1 to 1.2 (9.7 to 10.6)
	X, Y, Z		2 to 3.5		12		4		1.1 to 1.2 (9.7 to 10.6)
	r, s, t	2	2	14	14	2.5	2.5	M4	1.1 to 1.2 (9.7 to 10.6)
	⊕	3.5	3.5 to 5.5	10	12 to 10	2.5	2.5 to 6	M5	2.2 to 2.4 (19.1 to 21.2)
EUJ71090□	R/L1, S/L2, T/L3	8	8 to 80	8	8 to 3/0	6	6 to 70	M6	4.0 to 4.9 (35.4 to 43.4)
	X, Y, Z		8 to 22		8 to 4		6 to 25		4.0 to 4.9 (35.4 to 43.4)
	r, s, t	2	2	14	14	2.5	2.5	M4	1.1 to 1.2 (9.7 to 10.6)
	⊕	5.5	5.5 to 8	8	10 to 8	6	6 to 10	M6	4.0 to 4.9 (35.4 to 43.4)

### 3.8 Harmonic Filter Module Wiring

Model	Terminal	For Asia <1>		For U.S.A. <2>		For Europe and China <3>		Screw Size	Tightening Torque N·m (lb·in.)
		Recomm. Gauge mm <sup>2</sup>	Applicable Gauge mm <sup>2</sup>	Recomm. Gauge AWG	Applicable Gauge AWG	Recomm. Gauge mm <sup>2</sup>	Applicable Gauge mm <sup>2</sup>		
EUJ71091□	R/L1, S/L2, T/L3	14	14 to 80	6	6 to 3/0	10	10 to 70	M8	8.9 to 10.7 (79.7 to 97.4)
	X, Y, Z		14 to 38		6 to 1		10 to 35		8.9 to 10.7 (79.7 to 97.4)
	r, s, t	2	2 to 5.5	14	14 to 10	2.5	2.5 to 6	M4	1.1 to 1.2 (9.7 to 10.6)
	⊕	14	8 to 14	6	8 to 6	10	10 to 16	M8	8.9 to 10.7 (79.7 to 97.4)
EUJ71092□	R/L1, S/L2, T/L3	14	14 to 80	4	4 to 3/0	16	16 to 70	M8	8.9 to 10.7 (79.7 to 97.4)
	X, Y, Z		14 to 38		4 to 1		16 to 35		8.9 to 10.7 (79.7 to 97.4)
	r, s, t	2	2 to 5.5	14	14 to 10	2.5	2.5 to 6	M4	1.1 to 1.2 (9.7 to 10.6)
	⊕	14	14	6	6	16	16	M8	8.9 to 10.7 (79.7 to 97.4)
EUJ71093□	R/L1, S/L2, T/L3	38	38 to 80	2	2 to 3/0	25	25 to 70	M8	8.9 to 10.7 (79.7 to 97.4)
	X, Y, Z		38 to 80		2 to 3/0		25 to 70		8.9 to 10.7 (79.7 to 97.4)
	r, s, t	2	2 to 5.5	14	14 to 10	2.5	2.5 to 6	M4	1.1 to 1.2 (9.7 to 10.6)
	⊕	14	14	6	6	16	16	M8	8.9 to 10.7 (79.7 to 97.4)
EUJ71094□	R/L1, S/L2, T/L3	60	60 to 80	3 × 2P	3 to 3/0	50	50 to 70	M8	8.9 to 10.7 (79.7 to 97.4)
	X, Y, Z		60 to 80		3 to 3/0		50 to 70		8.9 to 10.7 (79.7 to 97.4)
	r, s, t	2	2 to 5.5	14	14 to 10	2.5	2.5 to 6	M4	1.1 to 1.2 (9.7 to 10.6)
	⊕	22	22	3	3	25	25	M8	8.9 to 10.7 (79.7 to 97.4)
EUJ71095□	R/L1, S/L2, T/L3	80 × 2P	80	3/0 × 2P	3/0	95	95	M12	32 to 40 (283 to 354)
	X, Y, Z		80		3/0		95		M12
	r, s, t	2	2 to 5.5	14	14 to 10	2.5	2.5 to 6	M4	1.1 to 1.2 (9.7 to 10.6)
	⊕	60	50 to 60	1/0	1/0 to 2/0	50	50 to 70	M12	32 to 40 (283 to 354)
EUJ71096□	R/L1, S/L2, T/L3	80 × 2P	80	3/0 × 2P	3/0	95 × 2P	95	M12	32 to 40 (283 to 354)
	X, Y, Z		80		3/0		95		M12
	r, s, t	2	2 to 5.5	14	14 to 10	2.5	2.5 to 6	M4	1.1 to 1.2 (9.7 to 10.6)
	⊕	60	50 to 100	1/0	1/0 to 4/0	95	50 to 95	M12	32 to 40 (283 to 354)

<1> Gauges listed here are for use in Japan.

<2> Gauges listed here are for use in the United States.

<3> Gauges listed here are for use in Europe and China.



## ■ Wiring a Harmonic Filter Module

**WARNING!** *Electrical Shock Hazard. Shut off the power supply to the converter before wiring the main circuit terminals. Failure to comply may result in death or serious injury.*

1. Loosen the screws on the faceplate and top cover and remove the faceplate and top cover.

**Note:** 1. The face plate and top cover can be removed by loosening these screws; they do not need to be removed.  
 2. EUJ71080□, EUJ71081□, EUJ71088□, EUJ71089□ have no screws on terminal covers.

EUJ71080□, EUJ71081□,  
 EUJ71088□, EUJ71089□

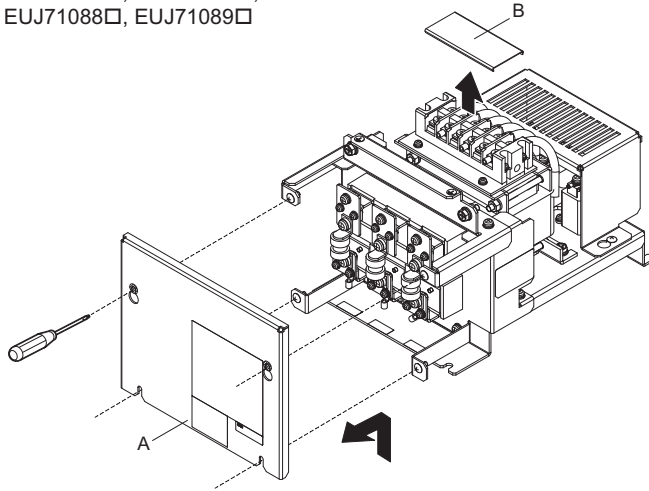

EUJ71082□ to EUJ71087□,  
 EUJ71090□ to EUJ71096□

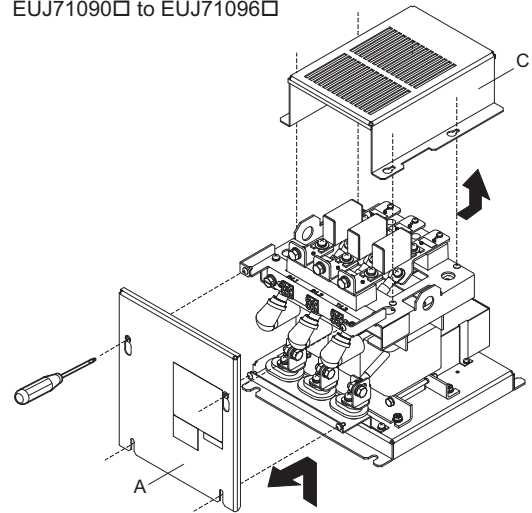

**A – Faceplate**  
**B – Terminal cover**

**C – Top cover**

Figure 3.30 Removing the Covers

2. Wire the r, s, and t terminals.

EUJ71080□, EUJ71081□,  
 EUJ71088□, EUJ71089□

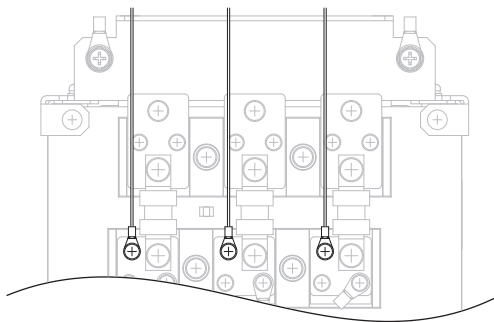

EUJ71082□ to EUJ71087□,  
 EUJ71090□ to EUJ71096□

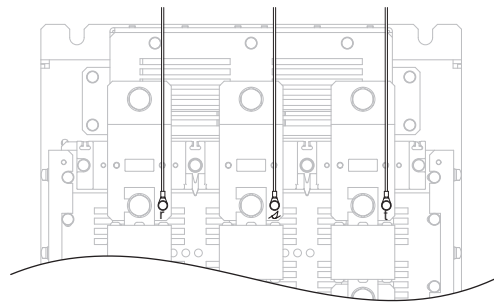

Figure 3.31 Wiring the r, s, and t Terminals

### 3.8 Harmonic Filter Module Wiring

3. Wire the R/L1, S/L2, and T/L3 terminals and then wire the X, Y, and Z terminals. Bundle the cables that are connected to the X, Y, and Z terminals and secure them with cable ties.

**Note:** Wire the ground terminal first and then wire the main circuit terminals.

EUJ71080□, EUJ71081□,  
EUJ71088□, EUJ71089□

EUJ71082□ to EUJ71087□,  
EUJ71090□ to EUJ71096□

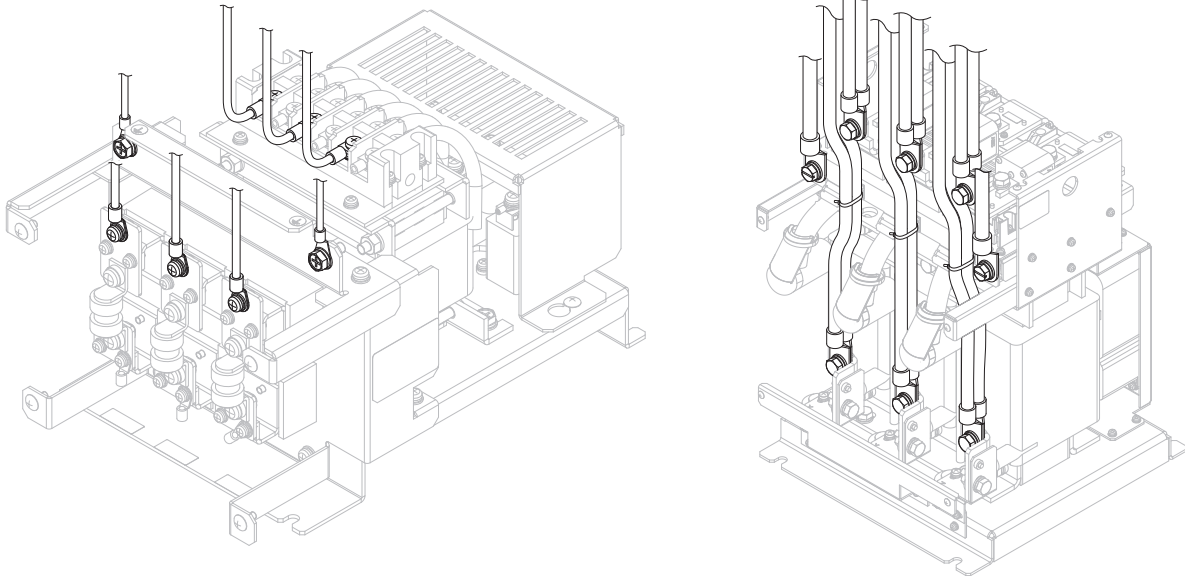

**Figure 3.32 Wiring a Harmonic Filter Module**

4. Reverse the previous procedure and connect the faceplate and top cover.

# 3.9 Control Circuit Wiring

**NOTICE:** Do not connect AC control circuit ground to converter enclosure. Improper converter grounding can cause control circuit malfunction.

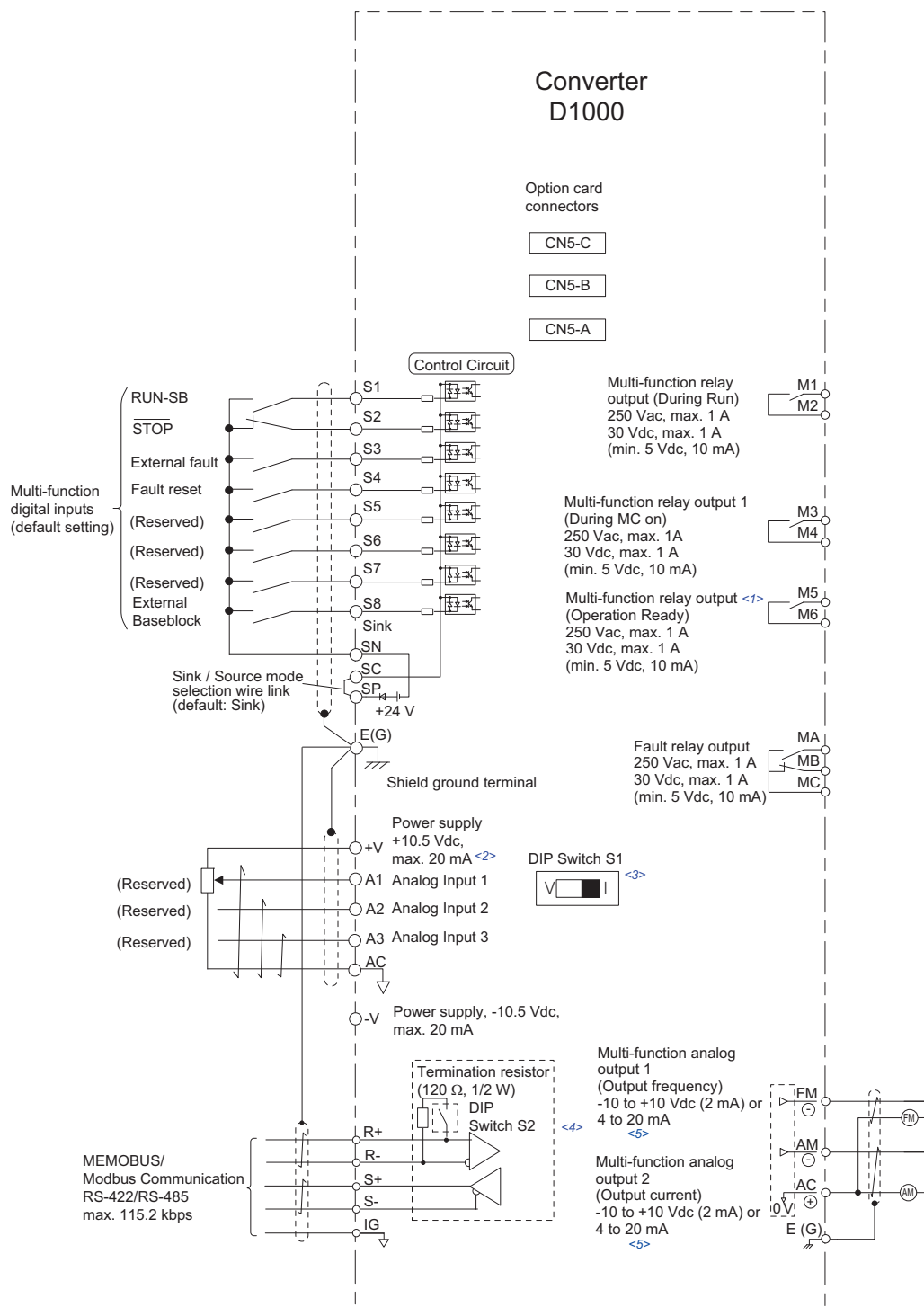

Figure 3.33 Control Circuit Wiring

- <1> The default setting is for Sinking Mode. Control is possible with no-voltage contacts or NPN transistors. For details, refer to [Control I/O Connections on page 81](#).
- <2> The maximum output current capacity for the +V and -V terminals on the control circuit is 20 mA. Never short terminals +V, -V, and AC, as it can cause erroneous operation or damage the converter.

### 3.9 Control Circuit Wiring

- <3> Set DIP switch S1 to select between a voltage or current input signal to terminal A2. The default setting is for current input. For details, refer to [Terminal A2 Input Signal Selection on page 81](#).
- <4> Set DIP switch S2 to the ON position to enable the termination resistor in a MEMOBUS/Modbus network.
- <5> Monitor outputs work with devices such as analog frequency meters, ammeters, voltmeters, and wattmeters. They are not intended for use as a feedback-type signal.

#### ◆ Control Circuit Terminal Block Functions

Parameters determine which functions apply to the multi-function digital inputs (S1 to S8), multi-function relay outputs (M1, M2, M3, M4, M5, M6), and multi-function analog monitor outputs (FM, AM). The default setting is listed next to each terminal name in [Table 3.8](#).

**NOTICE:** Install an MC on the power supply side of the converter when the drive should not automatically restart after power loss. To get the full performance life out of the electrolytic capacitors and circuit relays, refrain from switching the power supply off and on more than once every 30 minutes. Frequent use can damage the converter.

#### ■ Input Terminals

[Table 3.8](#) lists the input terminals on the converter. Text in parenthesis indicates the default setting for each multi-function input.

**Table 3.8 Control Circuit Input Terminals**

Type	No.	Terminal Name (Function)	Function (Signal Level) Default Setting	Page
Multi-Function Digital Inputs	S1	Multi-function input 1 (RUN-SB)	<ul style="list-style-type: none"> <li>• Photocoupler</li> <li>• 24 Vdc, 8 mA</li> <li>• Set the S3 jumper to select between sinking, sourcing mode, and the power supply. Refer to <a href="#">Control I/O Connections on page 81</a>.</li> </ul>	<b>186</b>
	S2	Multi-function input 2 (STOP)		
	S3	Multi-function input 3 (External fault)		
	S4	Multi-function input 4 (Fault reset)		
	S5	Multi-function input 5 (Reserved)		
	S6	Multi-function input 6 (Reserved)		
	S7	Multi-function input 7 (Reserved)		
	S8	Multi-function input 8 (External Baseblock)		
	SC	Multi-function input common		
	SP	Digital input power supply +24 Vdc		
	SN	Digital input power supply 0 V	<b>NOTICE:</b> Do not jumper or short terminals SP and SN. Failure to comply will damage the converter.	
Analog Inputs	+V	Analog reference input	10.5 Vdc (max allowable current 20 mA)	–
	-V	Analog reference input	-10.5 Vdc (max allowable current 20 mA)	–
	A1	Multi-function analog input 1 (Reserved)	-10 to 10 Vdc, 0 to 10 Vdc (input impedance: 20 kΩ)	<b>188</b>
	A2	Multi-function analog input 2 (Reserved)	<ul style="list-style-type: none"> <li>• -10 to 10 Vdc, 0 to 10 Vdc (input impedance: 20 kΩ)</li> <li>• 4 to 20 mA, 0 to 20 mA (input impedance: 250 Ω)</li> <li>• Voltage or current input must be selected by DIP switch S1 and H3-09.</li> </ul>	<b>189</b>
	A3	Multi-function analog input 3 (Reserved)	<ul style="list-style-type: none"> <li>• -10 to 10 Vdc, 0 to 10 Vdc (input impedance: 20 kΩ)</li> <li>• Use DIP switch S4 on the terminal board to select between analog and PTC input.</li> </ul>	<b>189</b>
	AC	Frequency reference common	0 V	–
	E (G)	Ground for shielded lines and option cards	–	–

## ■ Output Terminals

Table 3.9 lists the output terminals on the converter. Text in parenthesis indicates the default setting for each multi-function output.

**Table 3.9 Control Circuit Output Terminals**

Type	No.	Terminal Name (Function)	Function (Signal Level) Default Setting	Page
Fault Relay Output	MA	N.O. output (Fault)	30 Vdc, 10 mA to 1 A; 250 Vac, 10 mA to 1 A Minimum load: 5 Vdc, 10 mA	187
	MB	N.C. output (Fault)		
	MC	Fault output common		
Multi-Function Relay Output <->	M1	Multi-function relay output (During Run 1)	30 Vdc, 10 mA to 1 A; 250 Vac, 10 mA to 1 A Minimum load: 5 Vdc, 10 mA	187
	M2			
	M3	Multi-function relay output (During MC on)	30 Vdc, 10 mA to 1 A; 250 Vac, 10 mA to 1 A	
	M4			
	M5	Multi-function relay output (Operation Ready)	Minimum load: 5 Vdc, 10 mA	
	M6			
Monitor Output	FM	Analog monitor output 1 (Power Supply Side Power)	-10 to +10 Vdc, or 0 to +10 Vdc	190
	AM	Analog monitor output 2 (Power Supply Side Current)		
	AC	Monitor common	0 V	—

<1> Refrain from assigning functions to digital relay outputs that involve frequent switching, as doing so may shorten relay performance life. Switching life is estimated at 200,000 times (assumes 1 A, resistive load).

## ■ Serial Communication Terminals

**Table 3.10 Control Circuit Terminals: Serial Communications**

Type	No.	Signal Name	Function (Signal Level)		Page
MEMOBUS/ Modbus Communication <->	R+	Communications input (+)	MEMOBUS/Modbus communication: Use an RS-422 or RS-485 cable to connect the converter.	RS-422/RS-485 MEMOBUS/Modbus communication protocol 115.2 kbps (maximum)	206
	R-	Communications input (-)			
	S+	Communications output (+)			
	S-	Communications output (-)			
	IG	Shield ground	0 V		

<1> Enable the termination resistor in the last converter in a MEMOBUS/Modbus network by setting DIP switch S2 to the ON position.

### 3.9 Control Circuit Wiring

#### ◆ Terminal Configuration

The control circuit terminals are arranged as shown in *Figure 3.34*.

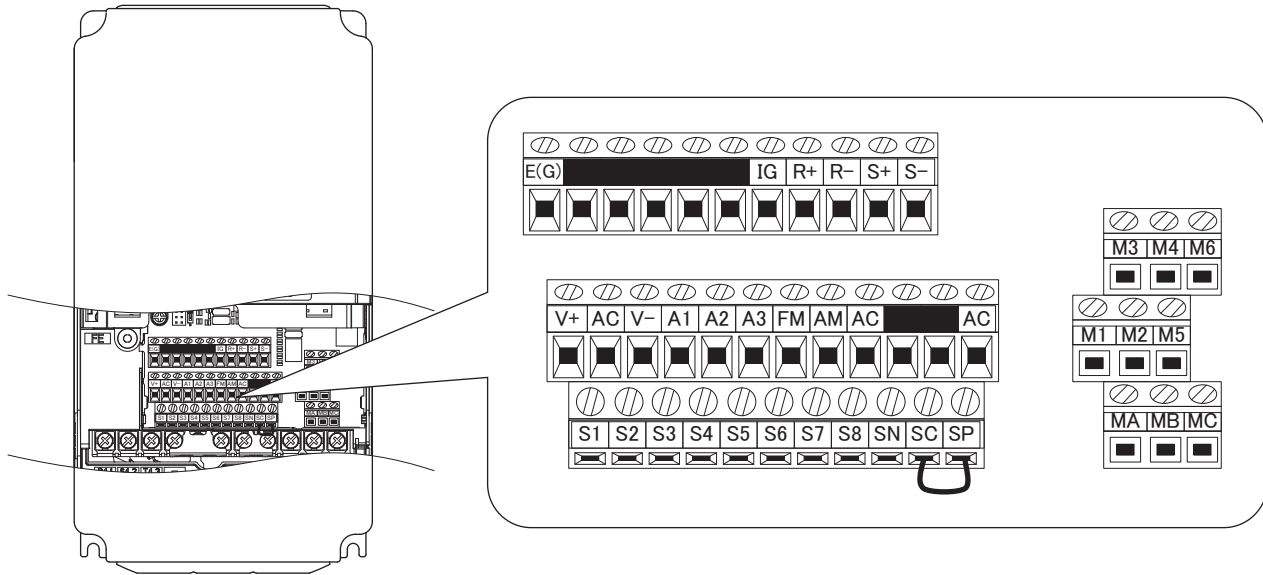

Figure 3.34 Control Circuit Terminal Arrangement

#### ■ Wire Size and Torque Specifications

Select appropriate wire type and gauges from *Table 3.11*.

For simpler and more reliable wiring, use crimp ferrules on the wire ends. Refer to *Table 3.12* for ferrule terminal types and sizes.

Table 3.11 Wire Gauge and Torque Specifications

Terminal	Screw Size	Tightening Torque N·m (lb·in.)	Bare Wire Terminal		Ferrule-Type Terminal		Wire Type
			Recomm. Gauge mm <sup>2</sup> (AWG)	Applicable Gauge mm <sup>2</sup> (AWG)	Recomm. Gauge mm <sup>2</sup> (AWG)	Applicable Gauge mm <sup>2</sup> (AWG)	
FM, AC, AM, SC, SP, SN, A1, A2, A3, +V, -V, S1 to S8, MA, MB, MC, M1 to M6	M3.5	0.8 to 1.0 (7.1 to 8.6)	0.75 (18)	0.5 to 2 (20 to 14)	-	-	Shielded wire, etc.
E (G)	M3.5	0.8 to 1.0 (7.1 to 8.6)	1.25 (12)	0.5 to 2 (20 to 14)			
IG, R+, R-, S+, S-	M2	0.22 to 0.25 (1.9 to 2.2)	0.75 (18)	Stranded wire: 0.25 to 1.0 (24 to 17) Solid wire: 0.25 to 1.5 (24 to 16)	0.5 (20)	0.25 to 0.5 (24 to 20)	

## ■ Ferrule-Type Wire Terminals

Yaskawa recommends using CRIMPFOX 6, a crimping tool manufactured by PHOENIX CONTACT, to prepare wire ends with insulated sleeves before connecting to the converter. See [Table 3.12](#) for dimensions.

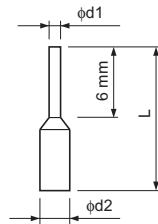

Figure 3.35 Ferrule Dimensions

Table 3.12 Ferrule Terminal Types and Sizes

Size mm <sup>2</sup> (AWG)	Type	L (mm)	d1 (mm)	d2 (mm)	Manufacturer
0.25 (24)	AI 0.25-6YE	10.5	0.8	2	PHOENIX CONTACT
0.34 (22)	AI 0.34-6TQ	10.5	0.8	2	
0.5 (20)	AI 0.5-6WH	14	1.1	2.5	

## ◆ Wiring the Control Circuit Terminal

This section describes the proper procedures and preparations for wiring the control terminals.

**WARNING!** *Electrical Shock Hazard. Do not remove covers or touch the circuit boards while the power is on. Failure to comply could result in death or serious injury.*

**NOTICE:** *Separate control circuit wiring from main circuit wiring (terminals R/L1, S/L2, T/L3, r1/l11, s1/l21, t1/l31, ⊖, ⊕) and other high-power lines. Improper wiring practices could result in converter malfunction due to electrical interference.*

**NOTICE:** *Separate wiring for digital output terminals MA, MB, MC, M1 to M6 from wiring to other control circuit lines. Improper wiring practices could result in converter or equipment malfunction or nuisance trips.*

**NOTICE:** *Use a class 2 power supply (UL standard) when connecting to the control terminals. Improper application of peripheral devices could result in converter performance degradation due to improper power supply.*

**NOTICE:** *Do not use unshielded cable for control wiring. Failure to comply may cause electrical interference resulting in poor system performance. Use shielded, twisted-pair wires and ground the shield to the ground terminal of the converter.*

**NOTICE:** *Insulate shields with tape or shrink tubing to prevent contact with other signal lines and equipment. Improper wiring practices could result in converter or equipment malfunction due to short circuit.*

**NOTICE:** *Connect the shield of shielded cable to the appropriate ground terminal. Improper equipment grounding could result in converter or equipment malfunction or nuisance trips.*

Wire the control circuit only after terminals have been properly grounded and main circuit wiring is complete.

Prepare the ends of the control circuit wiring as shown in [Figure 3.36](#). Refer to [Figure 3.38](#) for the treatment of the ends of the shield wire.

**NOTICE:** *Do not tighten screws beyond the specified tightening torque. Failure to comply may result in erroneous operation, damage to the terminal block, or cause a fire.*

**NOTICE:** *Use shielded twisted-pair cables as indicated to prevent operating faults. Improper wiring practices could result in converter or equipment malfunction due to electrical interference.*

Connect control wires as shown in [Figure 3.36](#) and [Figure 3.37](#).

### 3.9 Control Circuit Wiring

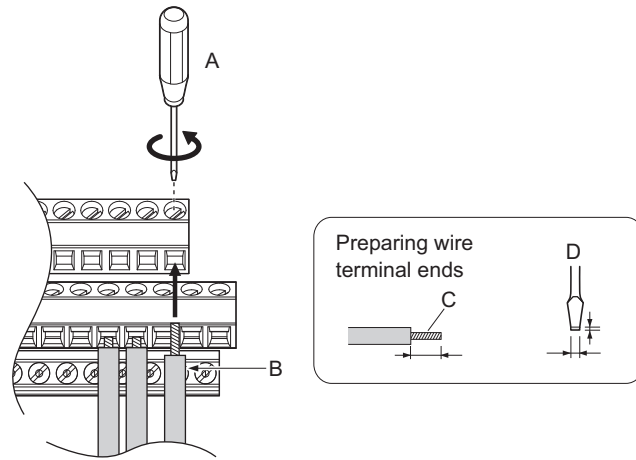

A – Loosen screw to insert wire.

C – Avoid fraying wire strands when stripping insulation from wire. Strip length 5.5 mm.

B – Single wire or stranded wire

D – Blade depth of 0.4 mm or less

E – Blade width of 2.5 mm or less

Figure 3.36 Terminal Board Wiring Guide

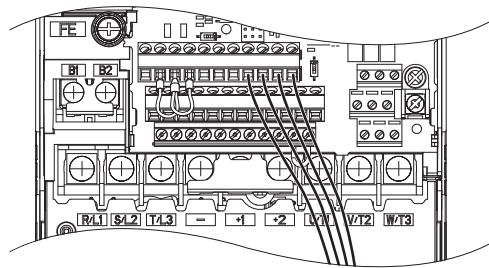
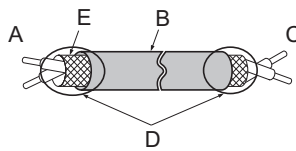

Figure 3.37 Terminal Board Location Inside the Converter

For the control circuit wires, use shielded twisted-pair wires that have been prepared as shown in [Figure 3.38](#).



A – Converter side

D – Shield sheath (insulate with tape)

B – Insulation

E – Shield

C – Control device side

Figure 3.38 Preparing the Ends of Shielded Cables

**NOTICE:** The analog signal wiring between the converter and the operator station or peripheral equipment should not exceed 50 meters when using an analog signal from a remote source. Failure to comply could result in poor system performance.



## 3.10 Control I/O Connections

Use the wire jumper between terminals SC and SP or SC and SN to select between Sink mode, Source mode or external power supply for the digital inputs S1 to S8 as shown in [Table 3.13](#) (Default: Sink mode, internal power supply).

**Note:** Never short terminals SP and SN as doing so will damage the converter.

**Table 3.13 Digital Input Sink / Source / External Power Supply Selection**

	Converter Internal Power Supply (Terminal SN and SP)	External 24 Vdc Power Supply
Sinking Mode (NPN)		
Sourcing Mode (PNP)		

### ◆ Terminal A2 Input Signal Selection

Terminal A2 can be used to input either a voltage or a current signal. Select the signal type using switch S1 as explained in [Table 3.14](#). Set parameter H3-09 accordingly as shown in [Table 3.15](#). Refer to [Figure 3.39](#) for locating switch S1.

To set the DIP switch, use tweezers or a tool with a tip width of approximately 0.8 mm.

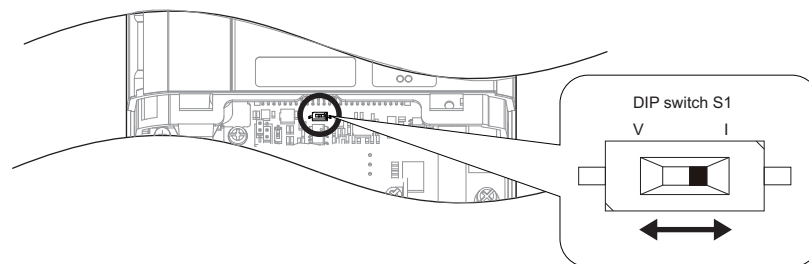

**Figure 3.39 DIP Switch S1**

**Table 3.14 DIP Switch S1 Settings**

Setting	Description
V (left position)	Voltage input (-10 to +10 V or 0 to 10 V)
I (right position)	Current input (4 to 20 mA or 0 to 20 mA): default setting

### 3.10 Control I/O Connections

Table 3.15 Parameter H3-09 Details

No.	Parameter Name	Description	Setting Range	Default Setting
H3-09	Terminal A2 signal level selection	Selects the signal level for terminal A2. 0: 0 to 10 Vdc 1: -10 to 10 Vdc 2: 4 to 20 mA 3: 0 to 20 mA	0 to 3	2

#### ◆ Using the Contact Outputs

Figure 3.40 illustrates the use of multi-function relay outputs and the fault relay outputs.

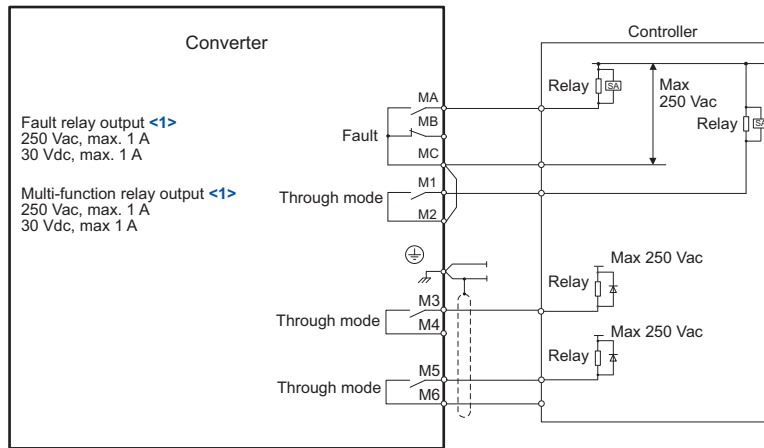

<1> Minimum load: 5 Vdc, 10 mA

Figure 3.40 Contact Outputs

#### ◆ Connect to a PC

This converter is equipped with a USB port (type-B).

The converter can connect to a USB port on a PC using a USB 2.0, AB-type cable (sold separately). After connecting the converter to a PC, Yaskawa DriveWizard Industrial software can be used to monitor converter performance and manage parameter settings. Contact Yaskawa for more information on DriveWizard Industrial.

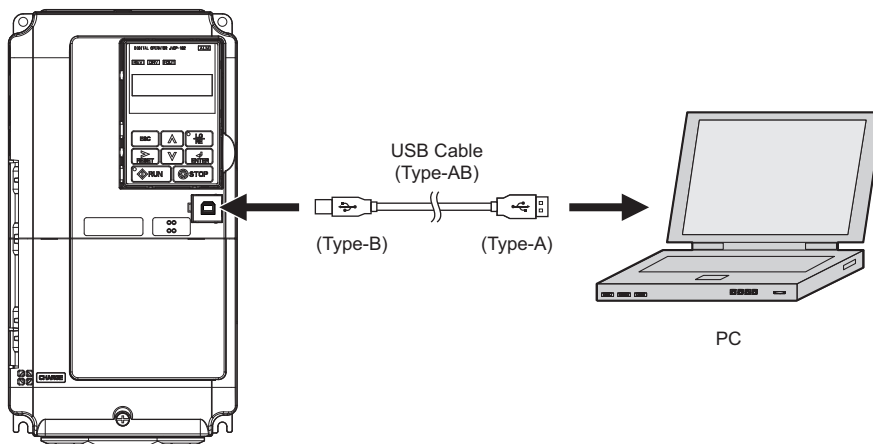

Figure 3.41 Connecting to a PC (USB)

## 3.11 Wiring Checklist

**NOTICE:** Check all the wiring to ensure that all connections are correct after installing the converter and connecting any other devices. Failure to comply could result in damage to the converter. To get the full performance life out of the electrolytic capacitors and circuit relays, refrain from switching the converter power supply off and on more than once every 30 minutes.

<input checked="" type="checkbox"/>	No.	Item	Page
<b>Converter, Peripherals, Option Cards</b>			
<input type="checkbox"/>	1	Check converter model number to ensure receipt of correct model.	23
<input type="checkbox"/>	2	Make sure you have the correct peripheral devices.	–
<input type="checkbox"/>	3	Check the option card model number.	–
<b>Installation Area and Physical Setup</b>			
<input type="checkbox"/>	4	Ensure that the area surrounding the converter complies with specifications.	29
<b>Power Supply Voltage, Output Voltage</b>			
<input type="checkbox"/>	5	The voltage from the power supply should be within the input voltage specification range of the converter.	–
<input type="checkbox"/>	6	The total load must be within the output specifications of the converter.	24
<input type="checkbox"/>	7	A power supply with a capacity (kVA) that is larger than the rated input capacity of the converter must be used.	–
<input type="checkbox"/>	8	The ratings must be correct.	24
<b>Main Circuit Wiring</b>			
<input type="checkbox"/>	9	Confirm proper branch circuit protection as specified by national and local codes.	–
<input type="checkbox"/>	10	Properly wire the converter.	54
<input type="checkbox"/>	11	Suitable wires must be used to wire the power supply and converter.	62
<input type="checkbox"/>	12	Properly ground the converter. Review page 66.	66
<input type="checkbox"/>	13	Tighten control circuit and grounding terminal screws. Refer to <i>Wire Gauges and Tightening Torque on page 62</i>	62
<b>Control Circuit Wiring</b>			
<input type="checkbox"/>	14	Use twisted-pair line for all converter control circuit wiring.	79
<input type="checkbox"/>	15	Ground the shields of shielded wiring to the GND ⊕ terminal.	49
<input type="checkbox"/>	16	Properly wire any option cards.	–
<input type="checkbox"/>	17	Check for any other wiring mistakes. Only use a multimeter to check wiring.	–
<input type="checkbox"/>	18	Properly fasten converter control circuit terminal screws. Refer to <i>Wire Size and Torque Specifications on page 78</i> .	78
<input type="checkbox"/>	19	Pick up all wire clippings.	–
<input type="checkbox"/>	20	Ensure that no frayed wires on the terminal block are touching other terminals or connections.	–
<input type="checkbox"/>	21	Properly separate control circuit wiring and main circuit wiring.	–
<input type="checkbox"/>	22	The line between the input-side AC reactor and converter must be 10 m or shorter and the DC bus line between the converter and drive must be 5 m or shorter.	–

### 3.11 Wiring Checklist

---

# Start-Up Programming & Operation

---

This chapter explains the functions of the digital operator and how to program the converter for initial operation.

<b>4.1</b>	<b>SECTION SAFETY</b> .....	<b>86</b>
<b>4.2</b>	<b>USING THE DIGITAL OPERATOR</b> .....	<b>87</b>
<b>4.3</b>	<b>THE DRIVE AND PROGRAMMING MODES</b> .....	<b>90</b>
<b>4.4</b>	<b>POWERING UP THE CONVERTER</b> .....	<b>94</b>
<b>4.5</b>	<b>OPERATION WITH THE DRIVE CONNECTED</b> .....	<b>95</b>
<b>4.6</b>	<b>VERIFYING PARAMETER SETTINGS AND BACKING UP CHANGES</b> .....	<b>99</b>
<b>4.7</b>	<b>TEST RUN CHECKLIST</b> .....	<b>102</b>

## 4.1 Section Safety

 **DANGER**

**Electrical Shock Hazard**

**Do not connect or disconnect wiring while the power is on.**

Failure to comply will result in death or serious injury.

 **WARNING**

**Electrical Shock Hazard**

**Do not operate equipment with covers removed.**

Failure to comply could result in death or serious injury.

The diagrams in this section may show converter without covers or safety shields to show details. Be sure to reinstall covers or shields before operating the converter and run the converter according to the instructions described in this manual.

**Do not remove covers or touch circuit boards while the power is on.**

Failure to comply could result in death or serious injury.

## 4.2 Using the Digital Operator

Use the digital operator to enter Run and Stop commands, edit parameters, and display data including fault and alarm information.

### ◆ LCD Display

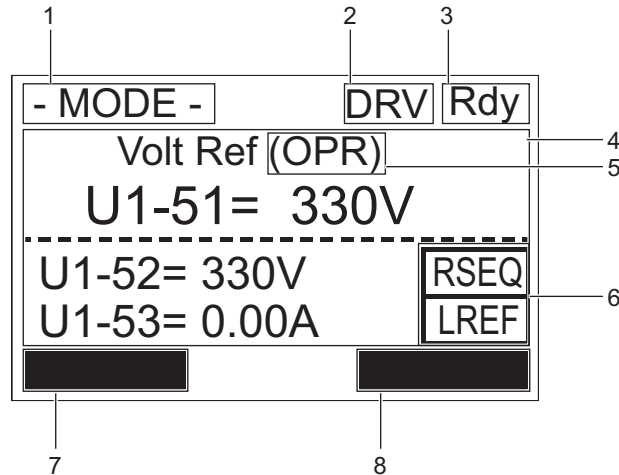









Figure 4.1 LCD Display

Table 4.1 Display and Contents

No.	Name	Display	Content
1	Operation Mode Menus	MODE	Displayed when in Mode Selection.
		MONITR	Displayed when in Monitor Mode.
		VERIFY	Indicates the Verify Menu.
		PRMSET	Displayed when in Parameter Setting Mode.
		SETUP	Displayed when in Setup Mode.
2	Mode Display Area	DRV	Displayed when in Drive Mode.
		PRG	Displayed when in Programming Mode.
3	Ready	Rdy	Indicates the converter is ready to run.
4	Data Display	-	Displays specific data and operation data.
5	DC Bus Voltage Reference Assignment </>	OPR	Displayed when the DC Bus Voltage Reference is assigned to the LCD Operator Option.
		AI	Displayed when the DC Bus Voltage Reference is assigned to the Analog Input.
		COM	Displayed when the DC Bus Voltage Reference is assigned to the MEMOBUS/Modbus Communication Inputs.
		OP	Displayed when the DC Bus Voltage Reference is assigned to a Option converter.
6	LO/RE Display </>	RSEQ	Displayed when the reference is supplied from a remote source.
		LSEQ	Displayed when the reference is supplied from the operator keypad.
		RREF	Displayed when the frequency reference is supplied from a remote source.
		LREF	Displayed when the frequency reference is supplied from the operator keypad.
7	Function Key 1 (F2)	HELP	Pressing  displays the Help menu.
		←	Pressing  scrolls the cursor to the left.
		HOME	Pressing  returns to the top menu (DC Bus Voltage Reference).
		ESC	Pressing  returns to the previous display.

## 4.2 Using the Digital Operator



No.	Name	Display	Content
8	Function Key 2 (F1)	DATA	Pressing  scrolls to the next display.
		→	Pressing  scrolls the cursor to the right.
		RESET	Pressing  resets the existing converter fault or error.

<1> Displayed when in DC Bus Voltage Reference Mode.

<2> Displayed when in DC Bus Voltage Reference Mode and Monitor Mode.





### ◆ ALARM (ALM) LED Displays

Table 4.2 ALARM (ALM) LED Status and Contents

State	Content	Display
Illuminated	When the converter detects a fault.	
Flashing	<ul style="list-style-type: none"> <li>When an alarm occurs.</li> <li>When oPE is detected.</li> </ul>	
Off	Normal operation (no fault or alarm).	

### ◆ LO/RE LED and RUN LED Indications

Table 4.3 LO/RE LED and RUN LED Indications

LED	Lit	Flashing	Off
	When source of the Run command is assigned to the digital operator (LOCAL)	—	When a device other than the operator is selected for Run command control (REMOTE)
	During run	Stopped for an operation interlock. <1>	During stop
Examples			

<1> The indicator flashes in the following cases:

- When REMOTE operation is restored after inputting a Run command from an external terminal during LOCAL operation.
- A Run command was input from an external terminal in any mode other than Drive Mode.
- The STOP key on the digital operator was pressed during REMOTE operation.



◆ Menu Structure for Digital Operator

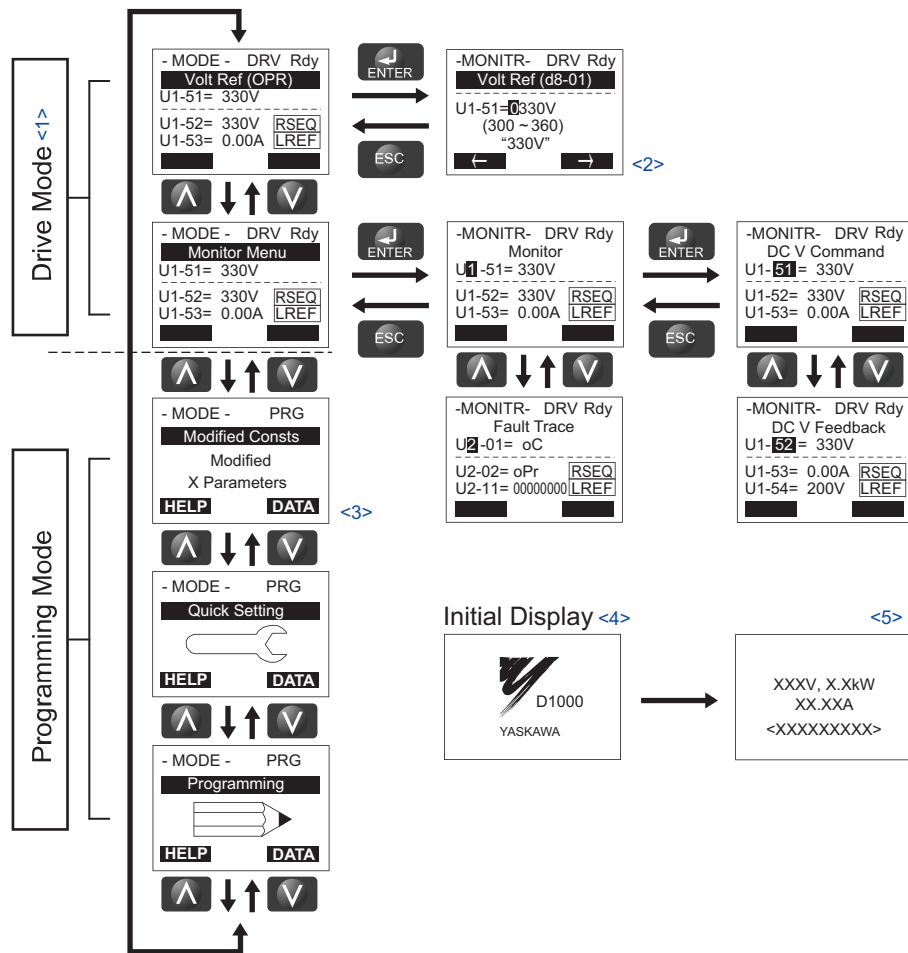

- <1> Pressing will start the converter operation.
- <2> Flashing characters are shown as **0**.
- <3> "X" characters are used as examples in this manual. The LCD Operator will display the actual setting values.
- <4> The DC Bus Voltage Reference appears after the initial display that shows the product name.
- <5> The information that appears on the display will vary depending on the converter.

Figure 4.2 Digital Operator Menu and Screen Structure

# 4.3 The Drive and Programming Modes

The converter has a Drive Mode and a Programming Mode.

**Drive Mode:** In Drive Mode the user can operate the converter, monitor operating status (DC bus voltage, DC current reference, etc.), and change the setting of d8-01. For details, refer to *Parameter Tables on page 181*.

**Programming Mode:** In Programming Mode the user can edit and verify parameter settings. When the converter is in Programming Mode it will not accept a Run command unless b1-08 is set to 1.

### ◆ Navigating the Drive and Programming Modes (Default Setting)

**NOTICE:** Check the following items before you turn on the power supply.

- Is the power supply voltage correct?  
200 V Class: 200 to 240 Vac 50/60 Hz  
400 V Class: 380 to 480 Vac 50/60 Hz
- Are the converter and the control devices connected properly (e.g., is the phase order correct)?
- Is the phase order correct between the main circuit terminals (R/L1, S/L2, and T/L3) on the converter and the power supply voltage detection terminals (r1/l1, s1/l2, and t1/l3)?
- Are the control circuit terminals on the converter connected properly to the control devices?
- Are the Run Commands for the converter and the control devices turned off?

The converter is set to operate in Drive Mode when it is first powered up. Switch between display screens by using the **▲** and **▼** keys.

### ■ Drive Mode Details

The following actions are possible in the Drive Mode:

- Run and stop the converter
- Monitor the operation status of the converter (DC bus voltage feedback, Power supply side voltage, Power supply side current, etc.)
- View information on an alarm
- View a history of alarms that have occurred

**Note:** The converter must be in Drive Mode to operate. Change to another mode when the converter is stopped.

**Figure 4.3** illustrates how to change the Output Voltage Reference from 600 (600 V) to 700 (700 V) while in the Drive Mode.

This example assumes the converter is set to LOCAL.

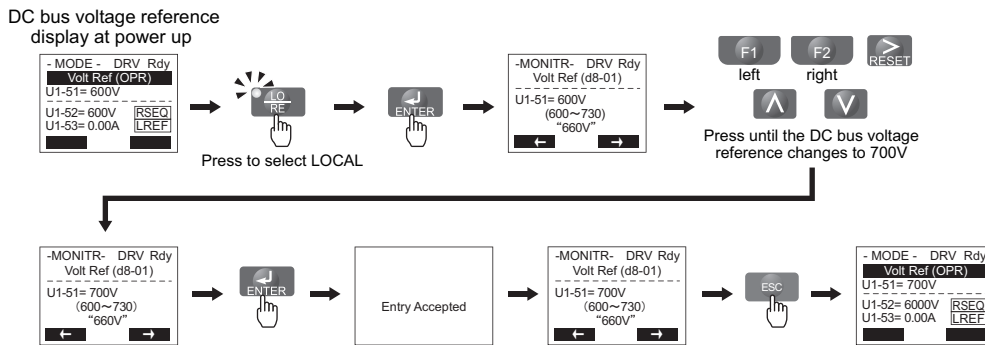

**Figure 4.3** Setting the DC Bus Voltage Reference while in the Drive Mode

**Note:** The converter will not accept a change to the value of DC bus voltage reference until the ENTER key is pressed after the value of DC bus voltage reference is entered. This feature prevents accidental setting of the value of DC bus voltage reference.

**■ Programming Mode Details**

The following actions are possible in the Programming Mode:

- **Verify Mode:** View a list of parameters that have been changed from the default values.
- **Setup Mode:** Access a list of commonly used parameters to simplify setup. Refer to *Setup Group Parameters on page 91*.
- **Parameter Setting Mode:** Access and edit all parameter settings.

**Setup Group Parameters**

Parameters most likely to be changed are assigned to the group of User Parameters, A2-01 through A2-32. User Parameters are part of the Setup Group, which provides quicker access by eliminating the need to scroll through multiple menus.

Table 4.4 lists the default settings of the A2-□□ parameters.

**Note:** Parameter b1-02 is displayed in Setup Mode regardless of A2-□□ parameter settings.

**Table 4.4 Setup Group Parameters**





A2-□□	Default	Name
A2-01	b1-18	Voltage Reference Source
A2-02	b1-02	Run Command Selection
A2-03	d8-01	DC Bus Voltage Reference

**◆ Changing Parameter Settings or Values**

This example explains changing b1-02 (Run Command Selection) from 01 to 00.

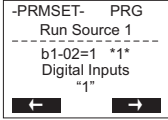
Step	Display/Result
1. Turn on the power to the converter. The initial display appears.	
2. Press the  or  key until the Parameter Setting Mode screen appears.	
3. Press the  key to enter the parameter menu tree.	
4. Press  or  key to select the B parameter group.	
5. Press  two times.	
6. Press  to view the current setting value (1). "1" Flashes.	

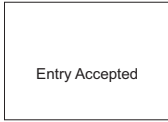
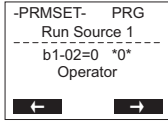

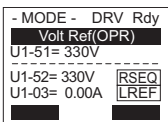



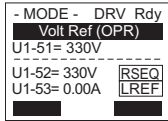

### 4.3 The Drive and Programming Modes

Step			Display/Result
7.	Press the  key and enter 0.	→	
8.	Press  and the converter will confirm the change.	→	
9.	The display automatically returns to the screen shown in Step 4.	→	
10.	Press the  key until back at the initial display.	→	

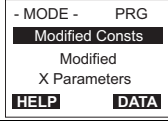
#### ◆ Verifying Parameter Changes: Verify Mode

The Verify Mode lists edited parameters from the Programming Mode. The Verify Mode helps determine which settings have been changed, and is particularly useful when replacing a converter. If no settings have been changed, the Verify Mode will read “None”. The Verify Mode also allows users to quickly access and re-edit any parameter settings that have been changed.

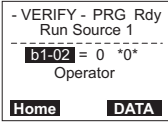
**Note:** A1-□□, and A2-01 to A2-32 are not displayed even when those parameters have been changed from their default values.

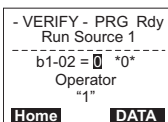
Step			Display/Result
1.	Turn on the power to the converter. The initial display appears.	→	
2.	Press  or  until the display shows the top of the Verify Menu.	→	
3.	Press  to enter the list of parameters that have been edited from their original default settings. If parameters other than b1-02 have been changed, use the  or  key to scroll until b1-02 appears.	→	
4.	Press the  key to access the setting value.	→	



◆ Switching Between LOCAL and REMOTE

LOCAL mode is when the converter is set to accept the Run command from the digital operator RUN key. REMOTE mode is when the converter is set to accept the Run command from an external device.

Switch the operation between LOCAL and REMOTE using the  key on the digital operator or via a digital input.

- Note:**
1. After selecting LOCAL, the LO/RE light will remain lit.
  2. The converter will not allow the user to switch between LOCAL and REMOTE during run.

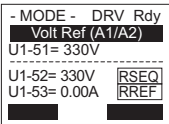
■ Using the LO/RE Key on the Digital Operator

Step		Display/Result
1	Turn on the power to the converter. The initial display appears.	
2	Press  . The LO/RE light will light up. The converter is now in LOCAL. To set the converter for REMOTE operation, press the key again.	

■ Using Input Terminals S1 through S8 to Switch between LOCAL and REMOTE

It is possible to switch between LOCAL and REMOTE modes using one of the digital input terminals S1 through S8 (set the corresponding parameter H1-□□ to “1”).

Setting H1-□□ to 1 disables the LO/RE key on the digital operator.

## 4.4 Powering Up the Converter

### ◆ Powering Up the Converter and Operation Status Display

#### ■ Powering Up the Converter

Review the following checklist before turning the power on.

**NOTICE:** *Equipment Damage.* Check the following items before you turn on the power supply. Failure to comply could result in damage to the converter and harmonic filter module.

Item to Check	Description
Power supply voltage	Check the power supply voltage. 200 V class: Three-phase 200 to 240 Vac 50/60 Hz 400 V class: Three-phase 380 to 480 Vac 50/60 Hz
	Properly wire the power supply input terminals (R/L1, S/L2, and T/L3).
	Properly wire the phase order of the power supply input terminals (R/L1, S/L2, and T/L3) and the power supply voltage detection terminals (r1/l11, s1/l21, and t1/l31).
	Check for proper grounding of converter.
Converter output terminals and drive terminals	Properly connect the DC voltage output terminals (⊕/⊖) on the converter to the DC power supply input terminals (⊕/⊖) on the drive. Be particularly careful to correctly connect the ⊕ and ⊖ terminals.
Control circuit terminals	Properly connect the control circuit terminals on the converter to other control devices.
Converter control terminal status	Turn off the Run Commands for the converter and the peripheral control devices.
Input-side AC reactor and harmonic filter (harmonic filter module) connections to converter	Properly connect the AC reactor and harmonic filter (harmonic filter module) to converter as shown in the Standard Connection Diagram.

#### ■ Status Display

When the power supply to the converter is turned on, the digital operator lights will appear as follows:

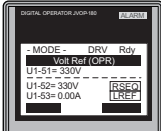
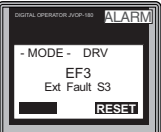
Status	Name	Description
Normal Operation		The data display area displays the DC bus voltage reference DC voltage feedback. <b>DRV</b> is lit.
Fault	 Example: External Fault	Data displayed varies by the type of fault. Refer to <a href="#">Troubleshooting on page 103</a> for more information. <b>DRV</b> and <b>ALM</b> are lit.

## 4.5 Operation with the Drive Connected

**NOTICE:** When installing a noise filter on the converter power supply, use a reactor-type noise filter (without a capacitor), such as a zero phase reactor, and install it after the MCCB on the power supply side. Do not install a filter with a built-in capacitor as the harmonic components may cause the capacitor to overheat or may damage the capacitor.

**NOTICE:** When installing a breaker or contactor on the converter side for an emergency shutoff, confirm that the CHARGE indicators on the drive and converter are not lit before closing the breaker or contactor on the converter output (DC) side. If the power supply is turned on while there is a voltage charge, an overcurrent will flow and the device may be damaged. Always confirm that the breaker or contactor on the converter output (DC) side is turned on before applying power to the converter.

### ◆ A1000 Connection Example

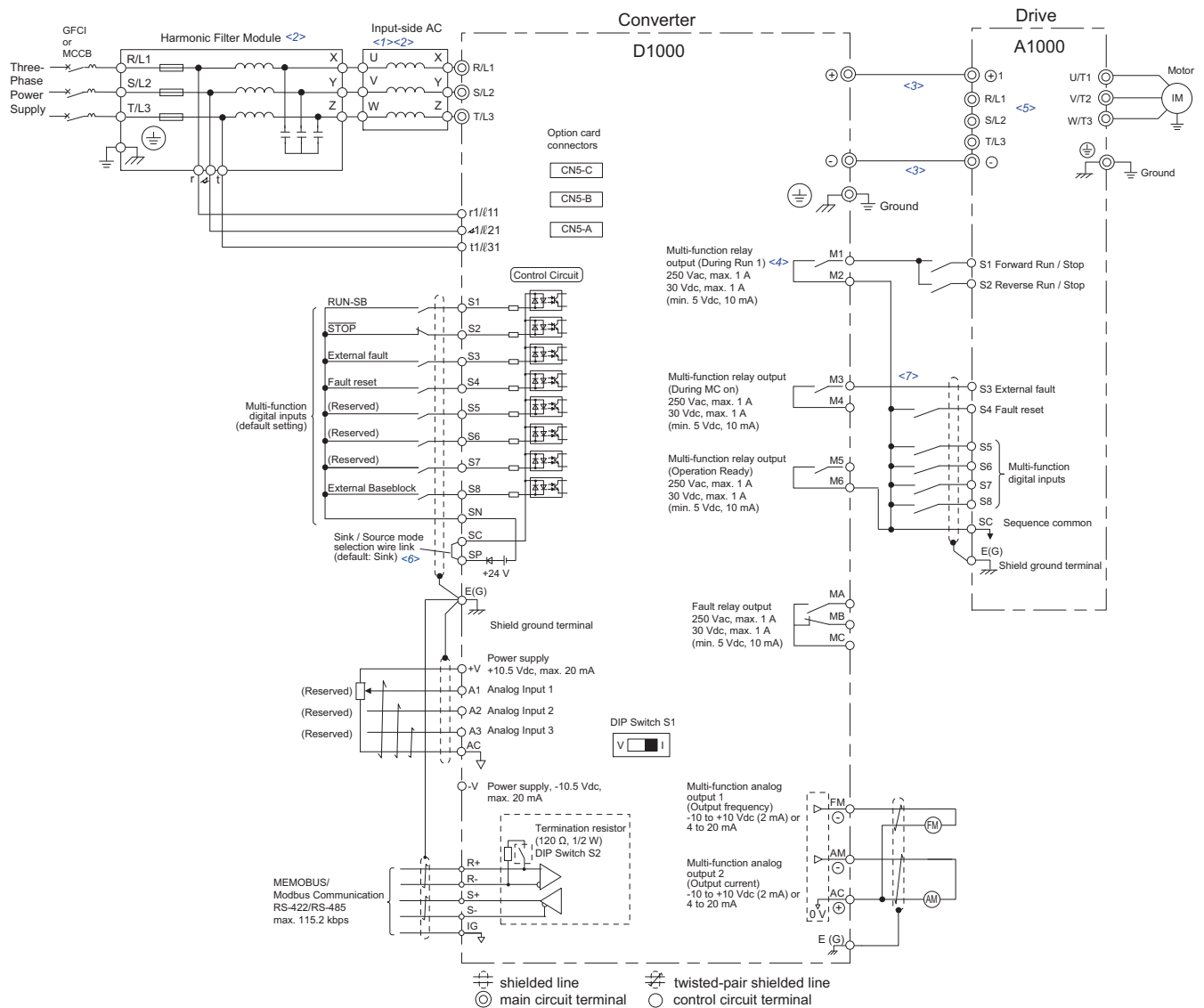

Figure 4.4 Standard Connection Diagram with A1000 (Example for CIMR-D□2A0030, 2A0130, and 4A0030 to 4A0185)

- <1> Do not use a line longer than 10 m (32.8 ft) to connect the input-side AC reactor and the converter.
- <2> Use the specified AC reactor and harmonic filter module. Non-specified devices may cause erroneous operation.
- <3> Do not use a DC bus line that is longer than 5 m (16.4 ft) to connect the converter and drive.
- <4> Sequence the operation so that the converter starts operation before the drive when power is applied. Sequence the stopping operation to turn off the drive first, then the motor, and finally the converter. Operating the drive without operating the converter or turning off the power supply unit during operation may trigger a converter fault.
- <5> Do not connect a power supply to the drive AC power supply terminals (R/L1, S/L2, and T/L3).
- <6> The connections are shown for sequence connections with no-voltage contacts or NPN transistors for the sequence input signals (S1 to S8). Use jumper S3 to select between Sink mode and Source mode. The default setting is Sink mode.
- <7> For information on an interlock with the drive, refer to [Interlock with the Drive on page 97](#).

## 4.5 Operation with the Drive Connected

**Note:** For information on connecting other control circuit I/O terminals, refer to the Quick Start Guide for the drive that is connected to the converter.

**WARNING! Sudden Movement Hazard.** Ensure all I/O circuits such as start/stop and safety circuits are set properly prior to application of main power to the converter. Failure to comply could result in sudden machine operation, which could result in death or serious injury.

### ◆ Varispeed G7 Connection Example

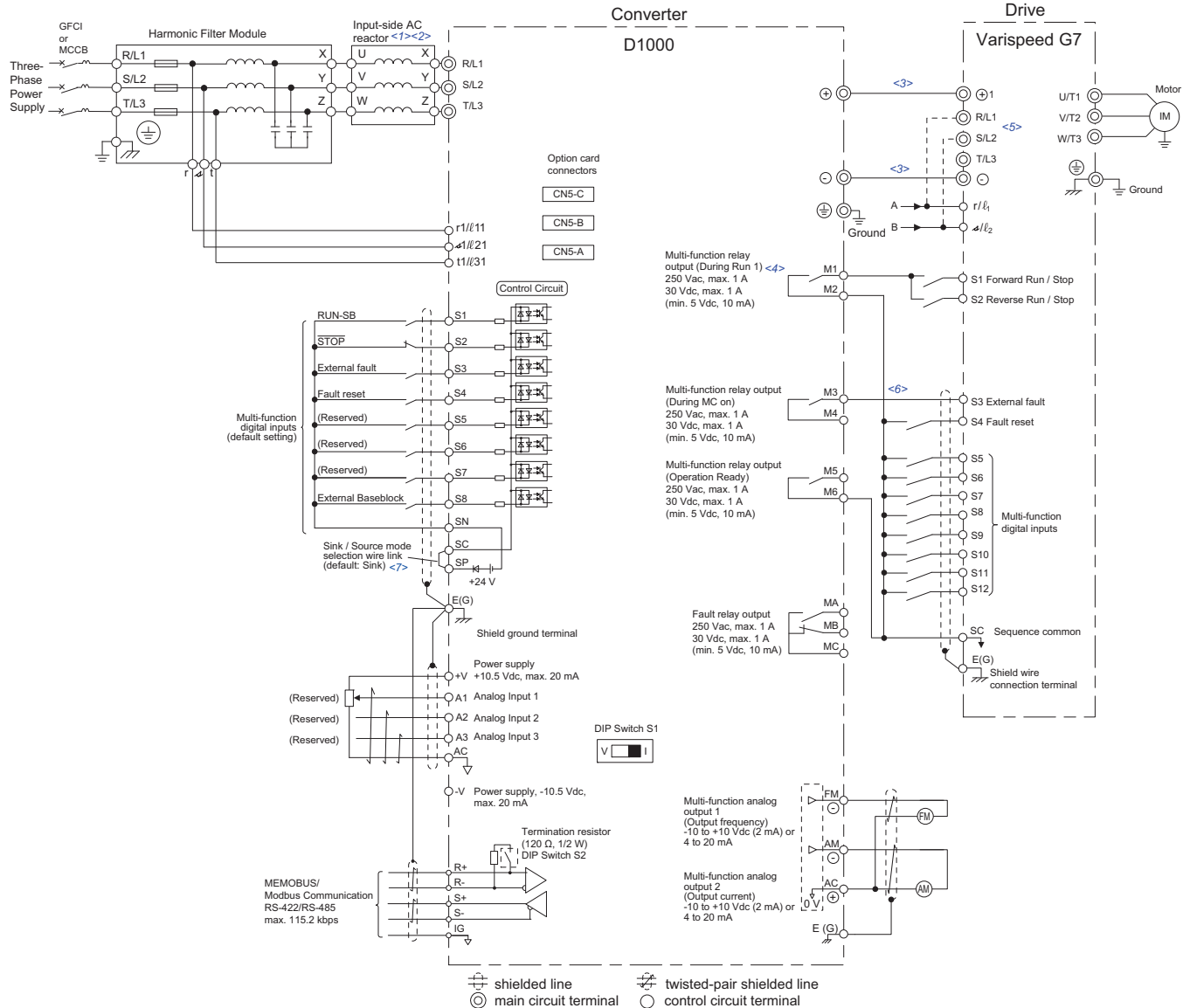

**Figure 4.5 Standard Connection Diagram with Varispeed G7 (Example for CIMR-D□4A0185)**

- <1> Do not use a line longer than 10 m (32.8 ft) to connect the input-side AC reactor and the converter.
- <2> Use the specified AC reactor and harmonic filter module. Non-specified devices may cause erroneous operation.
- <3> Do not use a DC bus line that is longer than 5 m (16.4 ft) to connect the converter and drive.
- <4> Sequence the operation so that the converter starts operation before the drive when power is applied. Sequence the stopping operation to turn off the drive first, then the motor, and finally the converter. Operating the drive without operating the converter or turning off the power supply unit during operation may trigger a converter fault.
- <5> Do not connect a power supply to the drive AC power supply terminals (R/L1, S/L2, and T/L3).
- <6> For information on an interlock with the drive, refer to [Interlock with the Drive on page 97](#).
- <7> This figure shows an example of a sequence input to S1 through S8 using a non-powered relay or an NPN transistor. Install the wire link between terminals SC-SP for Sink mode and SC-SN for Source mode. Leave it out for external power supply. Never short terminals SP and SN as doing so will damage the converter.

**WARNING! Sudden Movement Hazard.** Ensure all I/O circuits such as start/stop and safety circuits are set properly prior to application of main power to the converter. Failure to comply could result in sudden machine operation, which could result in death or serious injury.



## ◆ Timing Chart for Turning the Power Supply On and Off

Figure 4.6 is a timing chart for turning the power supply on and off.

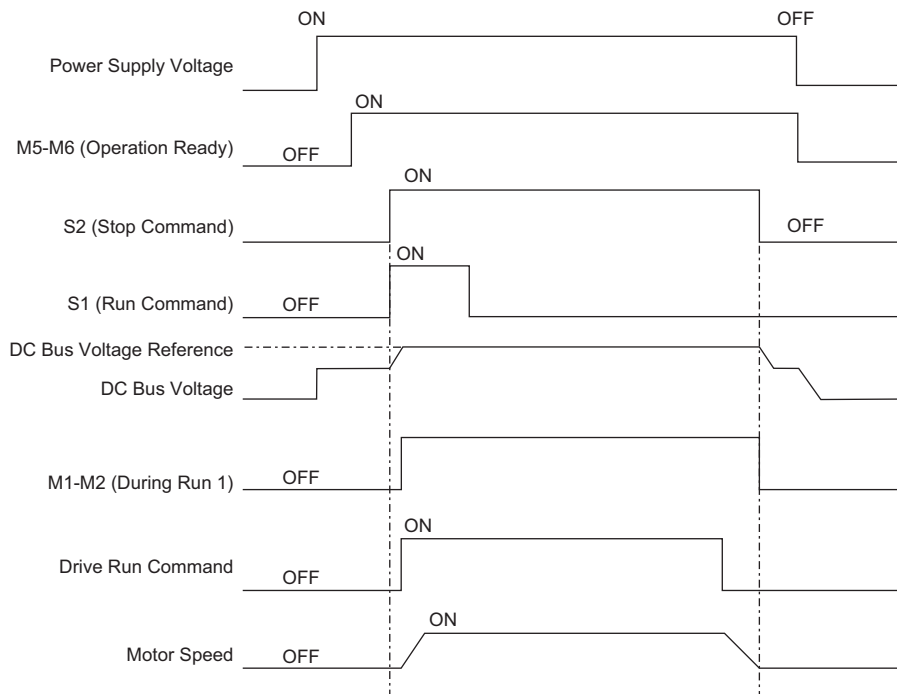

Figure 4.6 Timing Chart for Power ON and Run Command Sequence

Observe the following precautions when you perform operation with the converter connected to the drive.

- After turning on the power supply to the converter, wait for the Operation Ready signal on the multi-function contact output to turn on and then input the Run Command for the converter.
- Confirm that the converter is operating (i.e., confirm that During Run 1 is on) and then turn on the Run Command for the drive.
- To stop the converter, turn off the Run Command to the drive, confirm that the motor has stopped, and then input the Stop Command.
- Wait for the converter to stop and the During Run 1 multi-function contact output to turn off, then turn off the power supply.

## ◆ Interlocks

### ■ Interlock with the Drive

An interlock is required between the converter and the drive to stop the drive with a fault signal from the converter. It is also necessary to provide a suitable time to restart the drive if it will be restarted for momentary power losses.

Restarting can be timed with the “During MC on” signal that is output from a control terminal of the converter. Create a sequence to turn off the output from the drive with an external base block input to the drive or by a similar means when the terminal that is set for the “During MC on” signal opens.

The drive should be operated only when the converter is operating. The M1-M2 terminals (During Run 1) will confirm that the converter is operating, and the drive should be operated only when the During Run 1 signal is on. Stop the drive if the During Run 1 signal turns off.

## 4.5 Operation with the Drive Connected

### Not Restarting Operation for Momentary Power Loss (Stopping Operation When a Momentary Power Loss Is Detected)

Connect the “During MC on” signal from the converter to a multi-function contact input terminal on the drive that is assigned to an external fault.

Use an N.C. input for the external fault input on the drive and set the drive to detect external faults only during operation to prevent an external fault from being detected when the power supply is turned on.

### Restarting the System for Momentary Power Losses

- A1000

Connect the “During MC on” signal from the converter to a multi-function contact input terminal on the drive that is assigned to a Baseblock Command (N.C.).

- Control Devices Other Than the A1000

Connect the “During MC on” signal from the converter to a multi-function contact input terminal on the drive that is assigned to External Search Command 2.

(Contact your Yaskawa representative if you are using Yaskawa drive that does not have External Search Command 2.)

### ■ Stopping the Converter for Faults in Peripheral Devices

If an external device fails or a fault occurs, the fault contact output on the converter is activated to stop operation.

To use an external fault, set H1-□□ (terminal S1 to S8 function selection) to one of the values from [Table 4.5](#).

When an external fault is input, EF□ is displayed on the digital operator.

The □ in EF□ is the number of the terminal where the external fault signal was input.

Example: If an external fault signal is input to the S3 terminal, EF3 is displayed.

Select the number to set for H1-□□ according to the combination of the following three conditions:

- Use an input contact for a signal from the peripheral device.
- Use detection of an external fault.
- Stop operation (as the operation selection when an external fault is detected).

[Table 4.5](#) shows the relationship between the combination of conditions and the set value of H1-□□.

**Table 4.5 Combination of Conditions**

Setting Value	Input contact <1>		Detection <2>		Operation selection	
	N.O. contact	N.C. contact	Always detect	Detect only during operation	Stop converter (fault)	Continue operation (minor fault)
24	○	–	○	–	○	–
25	–	○	○	–	○	–
26	○	–	–	○	○	–
27	–	○	–	○	○	–
2C	○	–	○	–	–	○
2D	–	○	○	–	–	○
2E	○	–	–	○	–	○
2F	–	○	–	○	–	○

<1> When using an input contact, set whether to detect a fault when the signal opens or closes. (N.O.: External fault when closed, N.C.: External fault when open)

<2> When using detection of a fault, set whether to always detect faults or to detect them only during operation.

## 4.6 Verifying Parameter Settings and Backing Up Changes

Use the Verify Mode to check all changes to parameter settings. Refer to *Verifying Parameter Changes: Verify Mode on page 92*.

Save the verified parameter settings. Change the access level or set a password to the converter to prevent accidental modification of parameter settings.

### ◆ Backing Up Parameter Values: o2-03

Setting o2-03 to 1 saves all parameter settings to the converter internal memory. The converter can now recall all the saved parameters by performing a User Initialization (A1-03 = 1110).

No.	Parameter Name	Description	Setting Range	Default Setting
o2-03	User Defaults	Lets the user create a set of default settings for a User Initialization. 0: Saved/Not Set 1: Set Defaults - Saves current parameter settings as the default values for a User Initialization. 2: Clear All - Clears the currently saved user settings. After saving the user parameter set value, the items of 1110 (User Initialization) are displayed in A1-03 (User Parameter Default Value).	0 to 2	0
A1-03	Initialize Parameters	Selects a method to initialize the parameters. 0: No Initialize 1110: User Initialization (The user must first program and store desired settings using parameter o2-03) 2220: 2-Wire Initialization (parameter initialized prior to shipment) 5550: oPE4 Fault reset	0, 0110, 2220, 5550	0

### ◆ Parameter Access Level: A1-01

Setting the Access Level for “Operation only” (A1-01 = 0) allows the user to access parameters A1-□□ and U□-□□ only.

Other parameters are not displayed.

Setting the Access Level for “User Parameters” (A1-01 = 1) allows the user to access only the parameters that have been previously saved as User Parameters. This is helpful when displaying only the relevant parameters for a specific application.



No.	Parameter Name	Description	Setting Range	Default Setting
A1-01	Access Level Selection	Selects which parameters are accessible via the digital operator. 0: Operation only. A1-01, A1-04, and A1-06 can be set and monitored, and U□-□□ parameters can also be viewed. 1: User Parameters. Only recently changed parameters from application parameters A2-01 to A2-16 and A2-17 to A2-32 can be set and monitored. 2: Advanced Access Level. All parameters can be set and monitored.	0 to 2	2

## 4.6 Verifying Parameter Settings and Backing Up Changes

No.	Parameter Name	Description	Setting Range	Default Setting
A2-01 to A2-32	User Parameters 1 to 32	Parameters selected by the user are saved as User Parameters, including recently viewed parameters and parameters specifically selected for quick access. If parameter A2-33 is set to 1, recently viewed parameters will be listed between A2-17 and A2-32. Parameters A2-01 through A2-16 must be manually selected by the user. If A2-33 is set to 0, recently viewed parameters will not be saved to the group of User Parameters. A2-□□ parameters are now available for manual programming.	A1-00 to 04-19	–
A2-33	User Parameter Automatic Selection	0: Parameters A2-01 through A2-32 are reserved for the user to create a group of User Parameters. 1: Save history of recently viewed parameters. Recently edited parameters will be saved to A2-17 through A2-32 for quick access. The most recently changed parameter is saved to A2-17. The second most recently changed parameter is saved to A2-18, etc.	0,1	0

### ◆ Password Settings: A1-04, A1-05

The user can set a password in parameter A1-05 to restrict access to the converter. The password must be entered to A1-04 to unlock parameter access (i.e., parameter setting A1-04 must match the value programmed into A1-05). The following parameters cannot be viewed or edited until the value entered to A1-04 correctly matches the value set to A1-05: A1-01, A1-03, and A2-01 through A2-33.

**Note:** Parameter A1-05 is hidden from view. To display A1-05, access parameter A1-04 and press  and  simultaneously.

### ◆ Copy Function

Parameter settings can be copied to another converter to simplify parameter restoration or multiple converter setup. The converter supports the following copy options:

- **LCD Operator (standard in all models)**

The LCD operator used to operate the converter supports copying, importing, and verifying parameter settings. Refer to [o3: Copy Function on page 194](#) for details.

- **LED Operator**

The optional LED operator also supports copying, importing, and verifying parameter settings. Refer to the manual supplied with the LED operator for instructions.

- **USB Copy Unit and CopyUnitManager**

The copy unit is an external option connected to the converter to copy parameter settings from one converter and save those settings to another converter. Refer to the manual supplied with the USB Copy Unit for instructions.

**Note:** Connect the USB Copy Unit to the RS-422/RS-485 communication port on the converter.

CopyUnitManager is a PC software tool. It allows the user to load parameter settings from the Copy Unit onto a PC, or from the PC onto a Copy Unit. This is useful when managing parameters for various converters or applications. Refer to the manual supplied with CopyUnitManager for instructions.

### ■ Copying Procedure for the LCD Operator

The LCD operator can perform the following operations by changing the o3-01(Copy Function Selection) parameter in the converter.

#### **Read (o3-01 = 1)**

Copies all parameters from the converter to the LCD operator.

**Note:** There is a limit to the number of read operations that you can perform from the LCD operator. As a guide, do not perform more than 100,000 read operations.

#### **Copy (o3-01 = 2)**

Copies all parameters from the LCD operator to the converter.



#### **Verify (o3-01 = 3)**

Compares the parameters in the converter with the parameter settings saved on the LCD operator for matches.

## 4.7 Test Run Checklist

# 4.7 Test Run Checklist

Review the checklist before performing a test run. Check each item that applies.

<input checked="" type="checkbox"/>	No.	Checklist	Page
<input type="checkbox"/>	1	Thoroughly read the manual before performing a test run.	–
<input type="checkbox"/>	2	Check the <i>Wiring Checklist on page 83</i> .	83
<input type="checkbox"/>	3	Set the correct power supply voltage.	94
<input type="checkbox"/>	4	Turn on the power supply to the converter and drive.	94
<input type="checkbox"/>	5	Correctly sequence the Run commands.	97
<input type="checkbox"/>	6	The <b>DRV</b> should light after giving a Run command.	–
<input type="checkbox"/>	7	To give Run command and DC bus voltage reference from the digital operator, press  key to set to LOCAL.	87, 93
<input type="checkbox"/>	8	To give Run command and DC bus voltage reference from the control circuit terminals, press the  to set REMOTE. (The LO/RE indicator is lit off while REMOTE is set.)	93

## Troubleshooting

---

This chapter provides descriptions of the converter faults, alarms, errors, related displays, and guidance for troubleshooting. This chapter can also serve as a reference guide for tuning the converter during a trial run.

<b>5.1</b>	<b>SECTION SAFETY</b> .....	<b>104</b>
<b>5.2</b>	<b>ALARMS, FAULTS, AND ERRORS</b> .....	<b>105</b>
<b>5.3</b>	<b>FAULT DETECTION</b> .....	<b>109</b>
<b>5.4</b>	<b>ALARM DETECTION</b> .....	<b>120</b>
<b>5.5</b>	<b>OPERATOR PROGRAMMING ERRORS</b> .....	<b>128</b>
<b>5.6</b>	<b>COPY FUNCTION RELATED DISPLAYS</b> .....	<b>130</b>
<b>5.7</b>	<b>DIAGNOSING AND RESETTING FAULTS</b> .....	<b>131</b>

## 5.1 Section Safety

### WARNING

#### Electrical Shock Hazard

**If a fuse is open or ground fault circuit interrupter GFCI is tripped, check the wiring and the selection of the peripheral devices.**

Contact your supplier if the cause cannot be identified. Failure to comply may result in electrical shock by indirect or direct contact. The converter can cause a residual current with a DC component in the protective earthing conductor.

**After blowing a fuse or ground fault circuit interrupter GFCI is tripped, do not attempt to restart the converter or operate peripheral devices until five minutes pass and CHARGE lamp is OFF.**

Failure to comply could result in death, serious injury, and damage to the converter.

**Do not connect or disconnect wiring while the power is on.**

Failure to comply could result in death or serious injury.

Before servicing, disconnect all power to the equipment. The internal capacitor remains charged even after the power supply is turned off. The charge indicator LED will extinguish when the DC bus voltage is below 50 Vdc. To prevent electric shock, wait for at least the time specified on the warning label; after all indicators are OFF, measure for unsafe voltages to confirm the converter is safe prior to servicing.

**Do not operate equipment with covers removed.**

Failure to comply could result in death or serious injury.

The diagrams in this section may illustrate converter without covers or safety shields to display details. Be sure to reinstall covers or shields before operating the converter and run the converter according to the instructions described in this manual.

**Do not touch terminals before the capacitors have fully discharged.**

Failure to comply could result in death or serious injury.

Before servicing, disconnect all power to the equipment. The internal capacitor remains charged even after the power supply is turned off. The charge indicator LED will extinguish when the DC bus voltage is below 50 Vdc. To prevent electric shock, wait for at least the time specified on the warning label; after all indicators are OFF, measure for unsafe voltages to confirm the converter is safe prior to servicing.

**Do not allow unqualified personnel to perform work on the converter.**

Failure to comply could result in death or serious injury.

Installation, maintenance, inspection and servicing must be performed only by authorized personnel familiar with installation, adjustment and maintenance this equipment.

**Do not perform work on the converter while wearing loose clothing, jewelry, or without eye protection.**

Failure to comply could result in death or serious injury.

Remove all metal objects such as watches and rings, secure loose clothing and wear eye protection before beginning work on the converter.

**Do not remove covers or touch circuit boards while the power is on.**

Failure to comply could result in death or serious injury.



## 5.2 Alarms, Faults, and Errors

### ◆ Types of Alarms, Faults, and Errors

Check the digital operator for information about possible faults if the converter fails to operate.

If problems occur that are not covered in this manual, contact the nearest Yaskawa representative with the following information:

- Converter model
- Software version
- Date of purchase
- Description of the problem

**Table 5.1** contains descriptions of the various types of alarms, faults, and errors that may occur while operating the converter.

If the converter fails, contact your Yaskawa representative or the nearest Yaskawa sales office.

**Table 5.1 Types of Alarms, Faults, and Errors**

Type	Response
<b>Faults</b>	<p>When the converter detects a fault:</p> <ul style="list-style-type: none"> <li>• The digital operator displays text indicating the specific fault and the ALM indicator LED remains lit until the fault is reset.</li> <li>• The fault interrupts converter output.</li> <li>• Some faults allow the user to select the stopping method when the fault occurs.</li> <li>• Fault output terminals MA-MC will close, and MB-MC will open.</li> <li>• The converter will remain inoperable until the fault is cleared. Refer to <a href="#">Fault Reset Methods on page 131</a>.</li> </ul>
<b>Minor Faults and Alarms</b>	<p>When the converter detects an alarm or a minor fault:</p> <ul style="list-style-type: none"> <li>• The digital operator displays text indicating the specific alarm or minor fault, and the ALM indicator LED flashes.</li> <li>• A multi-function contact output set to be tripped by a minor fault (H2-□□ = 10) closes. If the output is set to be tripped by an alarm, the contact will not close.</li> </ul> <p>Remove the cause of the problem to reset a minor fault or alarm.</p>
<b>Operation Errors</b>	<p>An operation error occurs when parameter settings conflict or do not match hardware settings (such as with an option card). When the converter detects an operation error:</p> <ul style="list-style-type: none"> <li>• The digital operator displays text indicating the specific error.</li> <li>• Multi-function contact outputs do not operate.</li> </ul> <p>The converter will not operate until the error has been reset. Correct the settings that caused the operation error to clear the error.</p>
<b>Copy Function Errors</b>	<p>Copy Function Errors occur when using the digital operator or the USB Copy Unit to copy, read, or verify parameter settings.</p> <ul style="list-style-type: none"> <li>• The digital operator displays text indicating the specific error.</li> <li>• Multi-function contact outputs do not operate.</li> </ul> <p>Pressing any key on the digital operator will clear the fault. Investigate the cause of the problem (such as model incompatibility) and try again.</p>

## 5.2 Alarms, Faults, and Errors

### ◆ Alarm and Error Displays

#### ■ Faults

**Table 5.2** gives an overview of possible fault codes. Conditions such as overvoltages can trip faults and alarms. It is important to distinguish between faults and alarms to determine the proper corrective actions. When the converter detects a fault, the ALM indicator LED lights, the fault code appears on the digital operator, and the fault contact MA-MB-MC triggers. An alarm is present if the ALM LED blinks and the fault code on the digital operator flashes. Refer to *Minor Faults and Alarms on page 107* for a list of alarm codes.

**Table 5.2 Fault Displays**

Digital Operator Display		Name	Page	Digital Operator Display		Name	Page
LED	LCD			LED	LCD		
Aov	Aov	Power Supply Overvoltage	109	FUR	FUA	AC Fuse Blowout	113
AUv	AUv	Power Supply Undervoltage	109	FUd	FUd	DC Fuse Blowout	113
bUS	bUS	Option Communication Error	109	GF	GF	Ground Fault	113
CE	CE	MEMOBUS/Modbus Communication Error	109	nSE	nSE	Node Setup Error	113
CoF	CoF	Current Offset Fault	110	oC	oC	Overcurrent	113
CPF00, CPF01	CPF00, CPF01	Control Circuit Error	110	oFA00 to oFA43	oFA00 to oFA43	Option Card Fault (CN5-A)	114
CPF02	CPF02	A/D Conversion Error	110	oFb00 to oFb17	oFb00 to oFb17	Option Card Fault (CN5-B)	115
CPF03	CPF03	Control Board Connection Error	110	oFC00 to oFC55	oFC00 to oFC55	Option Card Fault (CN5-C)	115
CPF06	CPF06	EEPROM Memory Data Error	111	oH	oH	Heatsink Overheat	116
CPF07	CPF07	Terminal Board Connection Error	111	oH1	oH1	Overheat 1	116
CPF08	CPF08	Terminal Board Connection Error	111	oL2	oL2	Converter Overload	116
CPF11, CPF22 <1>	CPF11 to CPF22	Control Circuit Error	110	oPr	oPr	Operator Connection Fault	117
CPF23	CPF23	Control Board Connection Error	111	ov	ov	Overvoltage	117
CPF24	CPF24	Unit Capacity Detect Fault	111	PF2	PF2	Input Power Supply Fault	117
CPF26 to CPF35	CPF26 to CPF35	Control Circuit Error	110	PF3	PF3	Input Phase Loss Detection	117
E5	E5	MECHATROLINK Watchdog Timer Error	111	SC	SC	IGBT Short Circuit or Ground Fault	118
EF0	EF0	Option Card External Fault	111	SrC	SrC	Phase Order Fault	118
EF1 to EF8	EF1 to EF8	External Fault (input terminal S1 to S8)	111	Uv1	Uv1	Main Circuit Undervoltage	118
Err	Err	EEPROM Write Error	112	Uv2	Uv2	Control Power Supply Undervoltage	119
FAn	Fan	Internal Fan Fault	112	Uv3	Uv3	Soft Charge Circuit Fault	119
Fdv	Fdv	Power Supply Frequency Fault	112	vrE	vrE	Resonance Detection	119

<1> Displayed as CPF00 when occurring at converter power up. When one of the faults occurs after successfully starting the converter, the display will show CPF01. Displayed as CPF20 when occurring at converter power up. When one of the faults occurs after successfully starting the converter, the display will show CPF21.

### ■ Minor Faults and Alarms

Refer to [Table 5.3](#) for an overview of possible alarm codes. Conditions such as overvoltages can trip faults and alarms. It is important to distinguish between faults and alarms to determine the proper corrective actions. When the converter detects an alarm, the ALM indicator LED blinks and the alarm code display flashes. Most alarms trigger a digital output programmed for alarm output (H2-□□ = 10). A fault (not an alarm) is present if the ALM LED lights without blinking. Refer to [Faults on page 106](#) for information on fault codes.

**Table 5.3 Minor Fault and Alarm Displays**

Digital Operator Display		Name	Minor Fault Output (H2-□□ = 10)	Page
LED	LCD			
AEr	AEr	Station Number Setting Error	YES	120
Aov	Aov	Power Supply Overvoltage	YES	120
AUv	AUv	Power Supply Undervoltage	YES	120
bb	bb	Converter Baseblock	No output	120
bUS	bUS	Option Card Communications Error	YES	121
CALL	CALL	Serial Communication Transmission Error	YES	121
CE	CE	MEMOBUS/Modbus Communication Error	YES	121
CoF	CoF	Current Offset Fault	YES	122
CrST	CrST	Cannot Reset	YES	122
CyC	CyC	MECHATROLINK Communications Cycle Setting Error	YES	122
E5	E5	MECHATROLINK Watchdog Timer Error	YES	122
EF0	EF0	Option Card External Fault	YES	122
EF1 to EF8	EF1 to EF8	External Fault (input terminal S1 to S8)	YES	123
FAn	Fan	Converter Internal Fan Fault	YES	123
Fdv	Fdv	Power Supply Frequency Fault	YES	123
HCA	HCA	Current Alarm	YES	124
LT-1	LT-1	Cooling Fan Maintenance Time	No output <1>	124
LT-2	LT-2	Capacitor Maintenance Time	No output <1>	124
LT-3	LT-3	Capacitor Maintenance Time	No output <1>	124
oH	oH	Heatsink Overheat	YES	124
oL2	oL2	Converter Overheat	YES	125
ov	ov	Overvoltage	YES	125
PAUv	PAUv	Power Supply Undervoltage Pre-alarm	YES	125
PF3	PF3	Input Phase Loss Detection	YES	126
SE	SE	MEMOBUS/Modbus Test Mode Fault	YES	126
StC	StC	Phase Order Fault	YES	126
Uv	Uv	Undervoltage	YES	126
vrE	vrE	Resonance Detection	YES	127

<1> Output when H2-□□ = 2F.

## 5.2 Alarms, Faults, and Errors

### ■ Operation Errors

Table 5.4 Operation Error Displays

Digital Operator Display		Name	Page
LED	LCD		
<i>Err</i>	Err	EEPROM Write Error	128
<i>oPE01</i>	oPE01	Converter Capacity Setting Error	128
<i>oPE02</i>	oPE02	Parameter Setting Range Error	128
<i>oPE03</i>	oPE03	Multi-Function Input Setting Error	128
<i>oPE04</i>	oPE04	Terminal Board Mismatch Error	129
<i>oPE05</i>	oPE05	Run Command Selection Error	129
<i>oPE07</i>	oPE07	Multi-Function Analog Input Selection Error	129
<i>oPE30</i>	oPE30	Incorrect Input Voltage Adjustment	129

### ■ Errors and Displays When Using the Copy Function

Table 5.5 Copy Errors

Digital Opera		Name	Page
LED	LCD		
<i>CoPY</i>	CoPy	Writing parameter settings (flashing)	130
<i>CPyE</i>	CPyE	Error writing data	130
<i>CSEr</i>	CSEr	Copy unit error	130
<i>dFPS</i>	dFPS	Converter model mismatch	130
<i>End</i>	End	Task complete	130
<i>iFEr</i>	iFEr	Communication error	130
<i>ndAT</i>	ndAT	Model, voltage class, capacity mismatch	130
<i>rdEr</i>	rdEr	Error reading data	130
<i>rEAd</i>	rEAd	Reading parameter settings (flashing)	130
<i>vAEr</i>	vAEr	Voltage class, capacity mismatch	130
<i>vFyE</i>	vFyE	Parameter setting mismatch	130
<i>vrFy</i>	vrFy	Comparing parameter settings (flashing)	130

## 5.3 Fault Detection

### ◆ Fault Displays, Causes, and Possible Solutions

Table 5.6 Detailed Fault Displays, Causes, and Possible Solutions

Digital Operator Display		Fault Name	Details
$\overline{POV}$	Aov	Power Supply Overvoltage	The input power supply voltage became equal to or higher than the Input Power Supply Overvoltage Detection Level (L8-36). 200 V Class: Approximately 277 Vac 400 V Class: Approximately 554 Vac
<b>Cause</b>		<b>Possible Solution</b>	
The input power supply voltage is too high.		Reduce the voltage to within the range in the power supply specifications.	
Digital Operator Display		Fault Name	Details
$\overline{UV}$	AUv	Power Supply Undervoltage	The input power supply voltage became equal to or lower than the Input Power Supply Undervoltage Detection Level. 200 V Class: Approximately 150 Vac 400 V Class: Approximately 300 Vac
<b>Cause</b>		<b>Possible Solution</b>	
The capacity of the power supply is too small.		Increase the capacity of the power supply.	
The AC fuse is open.		A transistor inside the converter was destroyed. The input wiring is ground-faulted or short-circuited. Or, the drive output is ground-faulted or short-circuited, which destroyed the output transistor. Consult with your Yaskawa representative or the nearest Yaskawa sales office.	
The distortion in the power supply is too large.		Lower the impedance of the input power supply wiring.	
A phase loss occurred in the input power supply.		Check the input power supply for phase loss or an imbalance in the interphase voltages. Investigate and correct the cause and reset the fault.	
Digital Operator Display		Fault Name	Details
$\overline{BUS}$	bUS	Option Communication Error	<ul style="list-style-type: none"> <li>The connection was lost after establishing initial communication.</li> <li>Only detected when the run command frequency reference is assigned to an option card.</li> </ul>
<b>Cause</b>		<b>Possible Solution</b>	
No signal was received from the PLC.		Check for faulty wiring.	
Faulty communications wiring or an existing short circuit.		<ul style="list-style-type: none"> <li>Correct the wiring.</li> <li>Check for disconnected cables and short circuits and repair as needed.</li> </ul>	
Communication data error occurred due to noise.		Check the various options available to minimize the effects of noise. <ul style="list-style-type: none"> <li>Counteract noise in the control circuit, main circuit, and ground wiring.</li> <li>Ensure that other equipment such as switches or relays do not cause noise. Use surge absorbers if necessary.</li> <li>Use only recommended cables or other shielded line. Ground the shield on the controller side or the converter input power side.</li> <li>Separate all communication wiring from drive power lines. Install an EMC noise filter to the converter power supply input.</li> </ul>	
The option card is damaged.		Replace the option card if there are no problems with the wiring and the error continues to occur.	
The option card is not properly connected to the converter.		The connector pins on the option card do not line up properly with the connector pins on the converter. Reinstall the option card.	
Digital Operator Display		Fault Name	Details
$\overline{CE}$	CE	MEMOBUS/Modbus Communication Error	Control data was not received for the CE detection time set to H5-09.
<b>Cause</b>		<b>Possible Solution</b>	
Faulty communications wiring or an existing short circuit.		Check for faulty wiring. <ul style="list-style-type: none"> <li>Correct the wiring.</li> <li>Check for disconnected cables and short circuits and repair as needed.</li> </ul>	

### 5.3 Fault Detection

Communication data error occurred due to noise.		<p>Check the various options available to minimize the effects of noise.</p> <ul style="list-style-type: none"> <li>• Counteract noise in the control circuit, main circuit, and ground wiring.</li> <li>• Use only recommended cables or other shielded line. Ground the shield on the controller side or the converter input power side.</li> <li>• Ensure that other equipment such as switches or relays do not cause noise. Use surge suppressors if required.</li> <li>• Separate all communication wiring from drive power lines. Install an EMC noise filter to the converter power supply input.</li> </ul>	
Digital Operator Display	Fault Name	Details	
[CoF]	CoF	Current Offset Fault	A fault occurred in adjustment of the automatic current offset when the power supply was turned on.
Cause		Possible Solution	
An error occurred in the power supply detection circuit.		<p>Cycle the power supply and check operation.</p> <p>If the fault occurs again, replace the board or converter. For information on board replacement, consult with your Yaskawa representative or the nearest Yaskawa sales office.</p>	
Digital Operator Display	Fault Name	Details	
[CPF00], [CPF01]	CPF00, CPF01 <->	Control Circuit Error	A fault occurred in the control circuit.
[CPF11] to [CPF22]	CPF11 to PF22 <->		
[CPF26] to [CPF35]	CPF26 to CPF35		
Cause		Possible Solution	
There is a self-diagnostic error in the control circuit.		<ul style="list-style-type: none"> <li>• Cycle power to the converter.</li> <li>• If the problem continues, replace the control board or the entire converter. Contact Yaskawa or a Yaskawa representative for instructions on replacing the control board.</li> </ul>	
Connector on the operator is damaged.		Replace the operator.	
Digital Operator Display	Fault Name	Details	
[CPF02]	CPF02	A/D Conversion Error	An A/D conversion error or control circuit error occurred.
Cause		Possible Solution	
Control circuit is damaged.		<p>Cycle power to the converter.</p> <p>If the problem continues, replace the control board or the entire converter. Contact Yaskawa or a Yaskawa representative for instructions on replacing the control board.</p>	
Digital Operator Display	Fault Name	Details	
[CPF03]	CPF03	Control Board Connection Error	Connection error between the control board and the converter
Cause		Possible Solution	
There is a connection error.		<p>Turn off the power and check the connection between the control board and the converter.</p> <p>If the problem continues, replace the control board or the entire converter. Contact Yaskawa or a Yaskawa representative for instructions on replacing the control board.</p>	
Converter fails to operate properly due to noise interference.		<p>Check the various options available to minimize the effects of noise.</p> <ul style="list-style-type: none"> <li>• Counteract noise in the control circuit, main circuit, and ground wiring.</li> <li>• Use only recommended cables or other shielded line. Ground the shield on the controller side or the converter input power side.</li> <li>• Ensure that other equipment such as switches or relays do not cause noise. Use surge suppressors if required.</li> <li>• Separate all communication wiring from converter power lines. Install an EMC noise filter to the converter power supply input.</li> </ul>	

Digital Operator Display		Fault Name	Details
<i>CPF06</i>	CPF06	EEPROM Memory Data Error	Error in the data saved to EEPROM
<b>Cause</b>		<b>Possible Solution</b>	
There is an error in EEPROM control circuit.		Turn off the power and check the connection between the control board and the converter. If the problem continues, replace the control board or the entire converter. Contact Yaskawa or a Yaskawa representative for instructions on replacing the control board.	
The power supply was switched off while parameters were being saved to the converter.		Reinitialize the converter (A1-03 = 2220, 3330).	
Digital Operator Display		Fault Name	Details
<i>CPF07</i>	CPF07	Terminal Board Connection Error	There is a faulty connection in the removable terminal block.
<i>CPF08</i>	CPF08		
<b>Cause</b>		<b>Possible Solution</b>	
There is a faulty connection between the terminal board and the control board.		<ul style="list-style-type: none"> <li>• Turn off the power and reconnect the terminal board.</li> <li>• If the problem continues, replace the control board or the entire converter. Contact Yaskawa or a Yaskawa representative for instructions on replacing the control board.</li> </ul>	
Digital Operator Display		Fault Name	Details
<i>CPF23</i>	CPF23	Control Board Connection Error	Connection error between the control board and the converter
<b>Cause</b>		<b>Possible Solution</b>	
Hardware is damaged.		Turn off the power and check the connection between the control board and the converter. If the problem continues, replace the control board or the entire converter. Contact Yaskawa or a Yaskawa representative for instructions on replacing the control board.	
Digital Operator Display		Fault Name	Details
<i>CPF24</i>	CPF24	Unit Capacity Detect Fault	The converter capacity cannot be detected correctly (converter capacity is checked when the converter is powered up).
<b>Cause</b>		<b>Possible Solution</b>	
Hardware is damaged.		If the problem continues, replace the control board or the entire converter. Contact Yaskawa or a Yaskawa representative for instructions on replacing the control board.	
Digital Operator Display		Fault Name	Details
<i>E5</i>	E5	MECHATROLINK Watchdog Timer Error	The watchdog timed out.
<b>Cause</b>		<b>Possible Solution</b>	
Data has not been received from the PLC.		Execute DISCONNECT or ALM_CLR, then issue a CONNECT command or SYNC_SET command and proceed to phase 3. Refer to the MECHATROLINK Option Technical Manual for more details on troubleshooting.	
Digital Operator Display		Fault Name	Details
<i>EF0</i>	EF0	Option Card External Fault	An external fault condition is present.
<b>Cause</b>		<b>Possible Solution</b>	
An external fault was received from the PLC and F6-03 is set to a value other than 3.		<ul style="list-style-type: none"> <li>• Remove the cause of the external fault.</li> <li>• Remove the external fault input from the PLC.</li> </ul>	
Problem with the PLC program		Check the PLC program and correct problems.	
Digital Operator Display		Fault Name	Details
<i>EF1</i>	EF1	External Fault (input terminal S1)	External fault at multi-function input terminal S1.
<i>EF2</i>	EF2	External Fault (input terminal S2)	External fault at multi-function input terminal S2.

### 5.3 Fault Detection

<i>EF3</i>	EF3	External Fault (input terminal S3)	External fault at multi-function input terminal S3.
<i>EF4</i>	EF4	External Fault (input terminal S4)	External fault at multi-function input terminal S4.
<i>EF5</i>	EF5	External Fault (input terminal S5)	External fault at multi-function input terminal S5.
<i>EF6</i>	EF6	External Fault (input terminal S6)	External fault at multi-function input terminal S6.
<i>EF7</i>	EF7	External Fault (input terminal S7)	External fault at multi-function input terminal S7.
<i>EF8</i>	EF8	External Fault (input terminal S8)	External fault at multi-function input terminal S8.
<b>Cause</b>		<b>Possible Solution</b>	
An external device tripped an alarm function.		Remove the cause of the external fault and reset the fault.	
Wiring is incorrect.		<ul style="list-style-type: none"> <li>• Properly connect the signal lines to the terminals assigned for external fault detection (H1-□□ = 20 to 2B).</li> <li>• Reconnect the signal line.</li> </ul>	
Multi-function contact input setting is incorrect.		<ul style="list-style-type: none"> <li>• Check for unused terminals set for H1-□□ = 20 to 2B (External Fault).</li> <li>• Change the terminal settings.</li> </ul>	
<b>Digital Operator Display</b>	<b>Fault Name</b>	<b>Details</b>	
<i>Err</i>	Err	EEPROM Write Error	
<b>Cause</b>		<b>Possible Solution</b>	
Electrical noise has corrupted data while writing to the EEPROM.		<ul style="list-style-type: none"> <li>• Press “ENTER” on the digital operator.</li> <li>• Correct the parameter setting.</li> <li>• Cycle power to the converter.</li> </ul>	
Hardware problem		If the problem continues, replace the control board or the entire converter. Contact Yaskawa or a Yaskawa representative for instructions on replacing the control board.	
<b>Digital Operator Display</b>	<b>Fault Name</b>	<b>Details</b>	
<i>FAn</i>	Fan	Internal Fan Fault	
<b>Cause</b>		<b>Possible Solution</b>	
Internal cooling fan has malfunctioned.		<ul style="list-style-type: none"> <li>• Cycle power to the converter.</li> <li>• Check for fan operation.</li> </ul>	
Fault detected in the internal cooling fan or magnetic contactor to the power supply.		<ul style="list-style-type: none"> <li>• Verify the cumulative operation time of the fan with monitor U4-03, and verify the cumulative operation time of the fan maintenance timer with U4-04.</li> <li>• If the cooling fan has exceeded its expected performance life or is damaged in any other way, follow the replacement instructions in <a href="#">Cooling Fans on page 141</a>.</li> </ul>	
<b>Digital Operator Display</b>	<b>Fault Name</b>	<b>Details</b>	
<i>Fdv</i>	Fdv	Power Supply Frequency Fault	
<b>Cause</b>		<b>Possible Solution</b>	
A momentary power loss occurred.		Investigate and correct the cause and reset the fault. Refer to <a href="#">Diagnosing and Resetting Faults on page 131</a> .	
An input power supply wiring terminal is loose.			
The fluctuation in the voltage of the input power supply is too large.			
The AC power supply fuse is open.		<ul style="list-style-type: none"> <li>• A transistor inside the converter was destroyed.</li> <li>• The input wiring or drive output has ground faulted or short circuited.</li> </ul> Contact your Yaskawa representative or the nearest Yaskawa sales office.	



Digital Operator Display		Fault Name	Details
$FUR$	FUA	AC Fuse Blowout	The power supply fuse is open.
<b>Cause</b>		<b>Possible Solution</b>	
The power supply fuse is open.		<ul style="list-style-type: none"> <li>• A transistor inside the converter was destroyed.</li> <li>• The input wiring or drive output has ground faulted or short circuited.</li> </ul> Contact your Yaskawa representative or the nearest Yaskawa sales office.	
Digital Operator Display		Fault Name	Details
$FUD$	FUD	DC Fuse Blowout	The DC converter output fuse is open.
<b>Cause</b>		<b>Possible Solution</b>	
The main transistor failed.		Replace the converter.	
The DC circuit fuse is open.			
The drive failed.		Replace the drive. For information on drive replacement, consult with your Yaskawa representative or the nearest Yaskawa sales office.	
Digital Operator Display		Fault Name	Details
$GF$	GF	Ground Fault	A current that exceeded the Ground Short Detection Level was detected at the power supply side of the converter.
<b>Cause</b>		<b>Possible Solution</b>	
A damaged cable is creating a short circuit.		<ul style="list-style-type: none"> <li>• Check the cable.</li> <li>• Remove the short circuit and reapply power to the converter</li> </ul>	
		<ul style="list-style-type: none"> <li>• Check the resistance between the cable and the ground terminal ⊕.</li> <li>• Replace the cable.</li> </ul>	
Excessive leakage current at the drive output		Reduce the amount of stray capacitance.	
Hardware problem		If the problem continues, replace the control board or the entire converter. Contact Yaskawa or a Yaskawa representative for instructions on replacing the control board.	
The wiring of the power supply voltage detection circuits (r1/l11, A1/l21, t1/l31) and the wiring of the main circuit terminals (R/L1, S/L2, and T/L3) is not correct.		Correct the wiring.	
Digital Operator Display		Fault Name	Details
$nSE$	nSE	Node Setup Error	A terminal assigned to the node setup function closed during run.
<b>Cause</b>		<b>Possible Solution</b>	
The node setup terminal closed during run.		Stop the converter when using the node setup function.	
A Run command was issued while the node setup function was active.			
Digital Operator Display		Fault Name	Details
$oC$	oC	Overcurrent	Converter sensors detected an output current greater than the specified overcurrent level.
<b>Cause</b>		<b>Possible Solution</b>	
A momentary power loss occurred.		Investigate and correct the cause and reset the fault. Refer to <i>Diagnosing and Resetting Faults on page 131</i> for details.	
One of the cables has shorted out or there is a grounding problem.		<ul style="list-style-type: none"> <li>• Check the motor cables.</li> <li>• Remove the short circuit and reapply power to the converter.</li> </ul>	
		<ul style="list-style-type: none"> <li>• Check the resistance between the motor cables and the ground terminal ⊕.</li> <li>• Replace damaged cables.</li> </ul>	
The load is too heavy.		<ul style="list-style-type: none"> <li>• Measure the current flowing into the converter.</li> <li>• Replace the converter with a larger capacity converter if the current value exceeds the rated current.</li> <li>• Determine if there is sudden fluctuation in the current level.</li> <li>• Reduce the load to avoid sudden changes in the current level or switch to a larger converter.</li> </ul>	

### 5.3 Fault Detection

Converter fails to operate properly due to noise interference.		<ul style="list-style-type: none"> <li>Review the possible solutions provided for handling noise interference.</li> <li>Review the section on handling noise interference on page 393 and check the control circuit lines, main circuit lines, and ground wiring.</li> </ul>
The wiring of the power supply voltage detection circuits (r1/l11, s1/l21, t1/l31) and the wiring of the main circuit terminals (R/L1, S/L2, and T/L3) is not correct.		Correct the wiring.
The voltage on the power supply side is very low.		<ul style="list-style-type: none"> <li>Check the wiring. Correct the wiring.</li> <li>Check the load on the power supply of peripheral devices that are connected to the same power supply line. Reduce the load.</li> </ul>
Digital Operator Display	Fault Name	Details
oF A00	oFA00 Option Card Connection Error at Option Port CN5-A	Option compatibility error
Cause		Possible Solution
The option card installed into port CN5-A is incompatible with the converter.		Check if the converter supports the option card to be installed. Contact Yaskawa for assistance.
Digital Operator Display	Fault Name	Details
oF A01	oFA01 Option Card Fault at Option Port CN5-A	Option not properly connected
Cause		Possible Solution
The option card connection to port CN5-A is faulty.		Turn off the power and reconnect the option card.
Digital Operator Display	Fault Name	Details
oF A02	oFA02 Same Type of Option Card Already Connected	The combination of the option cards that are connected is not correct.
Cause		Possible Solution
The same option cards or the same type of option cards are connected to CN5-A, CN5-B, and CN5-C.		Connect the option cards correctly.
Digital Operator Display	Fault Name	Details
oF A05 to oF A06 oF A10, oF A11	oFA05 to oFA06 Option Card Error Occurred at Option Port CN5-A	There is a fault in the option card.
oF A12 to oF A17	oFA12 to oFA17 Option Card Connection Error (CN5-A)	
oF A30 to oF A43	oFA30 to oFA43 Communication Option Card Connection Error (CN5-A)	
Cause		Possible Solution
Option card or hardware is damaged.		<ul style="list-style-type: none"> <li>Cycle power to the converter.</li> <li>If the problem continues, replace the control board or the entire converter. Contact Yaskawa or a Yaskawa representative for instructions on replacing the control board.</li> </ul>

Digital Operator Display		Fault Name	Details
oFb00	oFb00	Option Card Fault at Option Port CN5-B	Option compatibility error
<b>Cause</b>		<b>Possible Solution</b>	
The option card installed into port CN5-B is incompatible with the converter.		Make sure the converter supports the option card to be installed. Contact Yaskawa for assistance.	
Digital Operator Display		Fault Name	Details
oFb01	oFb01	Option Card Fault at Option Port CN5-B	Option not properly connected
<b>Cause</b>		<b>Possible Solution</b>	
The option card connection to port CN5-B is faulty.		Turn off the power and reconnect the option card.	
Digital Operator Display		Fault Name	Details
oFb02	oFb02	Option Card Fault at Option Port CN5-B	Same type of option card is currently connected
<b>Cause</b>		<b>Possible Solution</b>	
An option card of the same type is already installed in option port CN5-A.		Only one of each option card type can only be installed simultaneously. Make sure only one type of option card is connected.	
Digital Operator Display		Fault Name	Details
oFb03 to oFb11	oFb03 to oFb11	Option card error occurred at Option Port CN5-B	There is a fault in the option card.
oFb12 to oFb17	oFb12 to oFb17	Option card error occurred at Option Port CN5-B	
<b>Cause</b>		<b>Possible Solution</b>	
Option card or hardware is damaged.		<ul style="list-style-type: none"> <li>• Cycle power to the converter.</li> <li>• If the problem continues, replace the control board or the entire converter. Contact Yaskawa or a Yaskawa representative for instructions on replacing the control board.</li> </ul>	
Digital Operator Display		Fault Name	Details
oFC00	oFC00	Option Card Connection Error at Option Port CN5-C	Option compatibility error
<b>Cause</b>		<b>Possible Solution</b>	
The option card installed into port CN5-C is incompatible with the converter.		Confirm that the converter supports the option card to be installed. Contact Yaskawa for assistance.	
Digital Operator Display		Fault Name	Details
oFC01	oFC01	Option Card Fault at Option Port CN5-C	Option not properly connected
<b>Cause</b>		<b>Possible Solution</b>	
The option card connection to port CN5-C is faulty.		Turn the power off and reconnect the option card.	
Digital Operator Display		Fault Name	Details
oFC02	oFC02	Option Card Fault at Option Port CN5-C	Same type of option card is currently connected
<b>Cause</b>		<b>Possible Solution</b>	
An option card of the same type is already installed in option port CN5-A or CN5-B.		Only one of each option card type can only be installed simultaneously. Make sure only one type of option card is connected.	

### 5.3 Fault Detection

Digital Operator Display		Fault Name	Details
oFC03 to oFC11	oFC03 to oFC11	Option Card Error Occurred at Option Port CN5-C	There is a fault in the option card.
oFC12 to oFC17	oFC12 to oFC17	Option Card Error Occurred at Option Port CN5-C	
<b>Cause</b>		<b>Possible Solution</b>	
Option card or hardware is damaged.		<ul style="list-style-type: none"> <li>• Cycle power to the converter.</li> <li>• If the problem continues, replace the control board or the entire converter. Contact Yaskawa or a Yaskawa representative for instructions on replacing the control board.</li> </ul>	
Digital Operator Display		Fault Name	Details
oFC50 to oFC55	oFC50 to oFC55	Option Card Error Occurred at Option Port CN5-C	Option card is damaged
<b>Cause</b>		<b>Possible Solution</b>	
Option card or hardware is damaged.		Refer to the option manual for details.	
Digital Operator Display		Fault Name	Details
oH	oH	Heatsink Overheat	The heatsink temperature exceeded the overheat pre-alarm level set to L8-02. The default value for L8-02 is determined by o2-04 (drive model selection).
<b>Cause</b>		<b>Possible Solution</b>	
Surrounding temperature is too high.		<ul style="list-style-type: none"> <li>• Check the temperature surrounding the converter. Verify temperature is within converter specifications.</li> <li>• Improve the air circulation within the enclosure panel.</li> <li>• Install a fan or air conditioner to cool the surrounding area.</li> <li>• Remove anything near the converter that might be producing excessive heat.</li> </ul>	
Load is too heavy.		<ul style="list-style-type: none"> <li>• Measure the output current.</li> <li>• Decrease the load.</li> </ul>	
Internal cooling fan is stopped.		<ul style="list-style-type: none"> <li>• Replace the cooling fan. Refer to page <a href="#">141</a> for details.</li> <li>• After replacing the cooling fan, set parameter o4-03 to 0 to reset the cooling fan maintenance.</li> </ul>	
Digital Operator Display		Fault Name	Details
oH1	oH1	Overheat 1	The heatsink temperature exceeded the converter overheat level. Overheat level is determined by o2-04 (drive model selection).
<b>Cause</b>		<b>Possible Solution</b>	
Surrounding temperature is too high.		<ul style="list-style-type: none"> <li>• Check the temperature surrounding the converter.</li> <li>• Improve the air circulation within the enclosure panel.</li> <li>• Install a fan or air conditioner to cool the surrounding area.</li> <li>• Remove anything near the converter that might be producing excessive heat.</li> </ul>	
Load is too heavy.		<ul style="list-style-type: none"> <li>• Measure the output current.</li> <li>• Reduce the load.</li> </ul>	
Internal cooling fan is stopped.		<ul style="list-style-type: none"> <li>• Replace the cooling fan. Refer to page <a href="#">141</a> for details.</li> <li>• After replacing the cooling fan, set parameter o4-03 to 0 to reset the cooling fan maintenance.</li> </ul>	
Digital Operator Display		Fault Name	Details
oL2	oL2	Converter Overload	The thermal sensor of the converter triggered the converter overload protection.
<b>Cause</b>		<b>Possible Solution</b>	
Load is too heavy.		Reduce the load.	
Converter capacity is too small.		Replace the converter with a larger model.	
The converter does not operate.		Start converter operation first, and then start converter operation.	

Digital Operator Display		Fault Name	Details
$\text{oPr}$	oPr	External Digital Operator Connection Fault	The external operator has been disconnected from the converter. <b>Note:</b> An oPr fault will occur when all of the following conditions are true: <ul style="list-style-type: none"> <li>• Output is interrupted when the operator is disconnected (o2-06 = 1).</li> <li>• The Run command is assigned to the operator (b1-02 = 0 and LOCAL has been selected).</li> </ul>
<b>Cause</b>		<b>Possible Solution</b>	
External operator is not properly connected to the converter.		<ul style="list-style-type: none"> <li>• Check the connection between the operator and the converter.</li> <li>• Replace the cable if damaged.</li> <li>• Turn off the input power and disconnect the operator. Reconnect the operator and reapply converter input power.</li> </ul>	
Digital Operator Display		Fault Name	Details
$\text{ov}$	ov	Overvoltage	Voltage in the DC bus has exceeded the overvoltage detection level. <ul style="list-style-type: none"> <li>• 200 V Class: Approximately 410 V</li> <li>• 400 V Class: Approximately 820 V</li> </ul>
<b>Cause</b>		<b>Possible Solution</b>	
A momentary power loss occurred.		Investigate and correct the cause and reset the fault. Refer to <i>Diagnosing and Resetting Faults on page 131</i> for details.	
The regenerative load is too large.		Reduce the regenerative load.	
Input power voltage is too high.		<ul style="list-style-type: none"> <li>• Check the voltage.</li> <li>• Lower input power voltage within the limits listed in the specifications.</li> </ul>	
Converter fails to operate properly due to noise interference.		<ul style="list-style-type: none"> <li>• Review the list of possible solutions provided for controlling noise.</li> <li>• Review the section on handling noise interference and check the control circuit lines, main circuit lines, and ground wiring.</li> </ul>	
The wiring of the power supply voltage detection circuits (r1/l11, a1/l21, t1/l31) and the wiring of the main circuit terminals (R/L1, S/L2, and T/L3) is not correct.		Correct the wiring.	
Digital Operator Display		Fault Name	Details
$\text{PF2}$	PF2	Input Power Supply Fault	Abnormal oscillation in the main circuit DC bus continued. (Applies when L8-65 is set to 1 or 2.)
<b>Cause</b>		<b>Possible Solution</b>	
The fluctuation in the voltage of the input power supply is too large.		Investigate and correct the cause and reset the fault. Refer to <i>Diagnosing and Resetting Faults on page 131</i> .	
A phase loss occurred in the input power supply.			
The capacity of the power supply is too small.			
The wiring is too long.			
The phase imbalance is too large.			
Digital Operator Display		Fault Name	Details
$\text{PF3}$	PF3	Input Phase Loss Detection	The voltage balance in the three-phase power supply has broken down. (Detected when L8-69 = 1.)
<b>Cause</b>		<b>Possible Solution</b>	
The fluctuation in the voltage of the input power supply is too large.		Investigate and correct the cause and reset the fault. Refer to <i>Diagnosing and Resetting Faults on page 131</i> .	
A phase loss occurred in the input power supply.			
The capacity of the power supply is too small.			
The wiring is too long.			
The phase imbalance is too large.			

### 5.3 Fault Detection

Digital Operator Display		Fault Name	Details
5C	SC	Input Short-circuit/ Main Transistor Failure	Short circuit or ground fault is detected.
<b>Cause</b>		<b>Possible Solution</b>	
IGBT fault		<ul style="list-style-type: none"> <li>• Check the wiring to the drive.</li> <li>• Turn the power supply off and then on again to check operation.</li> </ul>	
IGBT short circuit detection circuit fault.		If the problem continues, contact your Yaskawa representative or nearest Yaskawa sales office.	
Digital Operator Display		Fault Name	Details
5rC	SrC	Phase Order Fault	The phase order detection direction for the input power supply changed after the power supply was turned on.
<b>Cause</b>		<b>Possible Solution</b>	
The power supply phase order changed during operation.		Investigate and correct the cause and reset the fault. Refer to <i>Diagnosing and Resetting Faults on page 131</i> .	
A momentary power loss occurred.			
An input power supply wiring terminal is loose.			
The fluctuation in the voltage of the input power supply is too large.			
Digital Operator Display		Fault Name	Details
Uv1	Uv1	Main Circuit Undervoltage	The following condition occurred in the converter when a Run Command was not being input. The main circuit DC voltage became equal to or lower than the set value of L2-05 (Undervoltage Detection Level). 200 V Class: Approximately 190 V 400 V Class: Approximately 380 V
<b>Cause</b>		<b>Possible Solution</b>	
A phase loss occurred in the input power supply.		Check the wiring of the main circuit power supply for broken wires and wiring mistakes. Correct the wiring.	
An input power supply wiring terminal is loose.		Check the terminals for looseness. Tighten the terminals to the tightening torque that is given in this manual. (See page 62.)	
Fluctuation occurred in the power supply voltage.		Check the voltage. <ul style="list-style-type: none"> <li>• Correct the voltage so that it is within the range given in the power supply specifications of the converter.</li> <li>• If there is no problem with the main circuit power supply, check the magnetic contactor in the main circuit for faults.</li> </ul>	
A power loss occurred.		Improve the power supply.	
The main circuit capacitor circuit in the converter has deteriorated.		Check the maintenance period for the capacitor in U4-05 (Capacitor Maintenance). If the value of U4-05 has exceeded 90%, replace the board or the converter. For information on board replacement, consult with your Yaskawa representative or the nearest Yaskawa sales office.	
The operation of the relay or contactor in the inrush current protection circuit in the converter failed.		Cycle the power supply and see if the fault occurs again. <ul style="list-style-type: none"> <li>• If the fault occurs repeatedly, replace the board or the converter. For information on board replacement, consult with your Yaskawa representative or the nearest Yaskawa sales office. Check the maintenance period for the inrush prevention relay in U4-06 (Soft Charge Bypass Relay Maintenance).</li> <li>• If the value of U4-06 has exceeded 90%, replace the board or the converter. For information on board replacement, consult with your Yaskawa representative or the nearest Yaskawa sales office.</li> </ul>	
A fault occurred in the power supply device.		Check the wiring of the power supply device. Correct the wiring.	
A fault occurred in the power supply.		A fault occurred in the power supply.	
A fault occurred in power supply voltage detection.		Check the wiring. Correct the wiring.	

Digital Operator Display		Fault Name	Details
Uv2	Uv2	Control Power Supply Voltage Fault	Voltage is too low for the control converter input power.
<b>Cause</b>		<b>Possible Solution</b>	
Internal circuitry is damaged.		<ul style="list-style-type: none"> <li>• Cycle power to the converter. Check if the fault reoccurs.</li> <li>• If the problem continues, replace either the control board or the entire converter. For instructions on replacing the control board, contact Yaskawa or a Yaskawa representative.</li> </ul>	
Digital Operator Display		Fault Name	Details
Uv3	Uv3	Undervoltage 3 (Soft-Charge Bypass Circuit Fault)	The soft-charge bypass circuit failed.
<b>Cause</b>		<b>Possible Solution</b>	
The relay or contactor on the soft-charge bypass circuit is damaged.		<ul style="list-style-type: none"> <li>• Cycle power to the converter and see if the fault reoccurs.</li> <li>• If the problem continues, replace either the control board or the entire converter. For instructions on replacing the control board, contact Yaskawa or a Yaskawa representative.</li> <li>• Check monitor U4-06 for the performance life of the soft-charge bypass.</li> <li>• Replace either the control board or the entire converter if U4-06 exceeds 90%. For instructions on replacing the control board, contact Yaskawa or a Yaskawa representative.</li> </ul>	
Digital Operator Display		Fault Name	Details
Uv4 <>	Uv4	Gate Drive Board Undervoltage	Voltage drop in the gate drive board circuit
<b>Cause</b>		<b>Possible Solution</b>	
Not enough power is being supplied to the gate drive board.		<ul style="list-style-type: none"> <li>• Cycle power to the converter and see if the fault reoccurs. Refer to <i>Diagnosing and Resetting Faults on page 131</i> for details.</li> <li>• If the problem continues, replace either the gate drive board or the entire converter. For instructions on replacing the gate drive board, contact Yaskawa or a Yaskawa representative.</li> </ul>	
Digital Operator Display		Fault Name	Details
vrE	vrE	Resonance Detection	A filter resonance fault was detected or there is a harmonic component on the power supply side.
<b>Cause</b>		<b>Possible Solution</b>	
The power supply was turned off during operation.		Stop the operation of the converter and turn off the power supply.	
There is noise on the power supply line.		Investigate the source of the noise and implement countermeasures.	
A phase was lost for an input terminal during operation.		Check the wiring of the power supply system and remove the cause of the phase loss.	

<1> If the fault occurs when starting the converter, CPF00 or CPF20 is displayed. If it occurs during operation, CPF01 or CPF21 is displayed.  
 <2> Detected in model 4A0630.

## 5.4 Alarm Detection

### ◆ Alarm Codes, Causes, and Possible Solutions

Alarms are converter protection functions that do not necessarily cause the converter to stop. After removing the cause of an alarm, the converter will return to the same status as was before the alarm occurred.

When an alarm has been triggered, the ALM light on the digital operator display blinks and the alarm code display flashes. If a multi-function output is set for an alarm (H2-□□ = 10), that output terminal will be triggered.

**Note:** If a multi-function output is set to close when an alarm occurs (H2-□□ = 10), it will also close when maintenance periods are reached, triggering alarms LT-1 through LT-4 (triggered only if H2-□□ = 2F).

**Table 5.7 Alarm Codes, Causes, and Possible Solutions**

Digital Operator Display		Minor Fault Name	Detail	Alarm Output (H2-□□=10)
<i>AEr</i>	AEr	Communication Option Station Number Setting Error (CC-Link, CANopen, MECHATROLINK)	Option card node address is outside of the acceptable setting range.	YES
<b>Cause</b>		<b>Possible Solutions</b>		
Station number is set outside the possible setting range.		Set the station number of the option card correctly.		
Digital Operator Display		Minor Fault Name	Detail	Alarm Output (H2-□□=10)
<i>Aov</i>	Aov	Power Supply Overvoltage	The input power supply voltage became equal to or higher than the Input Power Supply Overvoltage Detection Level. 200 V Class: Approximately 277 Vac 400 V Class: Approximately 554 Vac	YES
<b>Cause</b>		<b>Possible Solutions</b>		
The input power supply voltage is too high.		Reduce the voltage to within the range in the power supply specifications.		
Digital Operator Display		Minor Fault Name	Detail	Alarm Output (H2-□□=10)
<i>AUv</i>	AUv	Power Supply Undervoltage	The input power supply voltage became equal to or lower than the Input Power Supply Undervoltage Detection Level. 200 V Class: Approximately 150 Vac 400 V Class: Approximately 300 Vac	YES
<b>Cause</b>		<b>Possible Solutions</b>		
The power supply voltage is low.		Increase the power supply voltage.		
A phase loss occurred in the input power supply.		Check the input power supply for phase loss or an imbalance in the interphase voltages. Investigate and correct the cause and reset the fault.		
Voltage detection failed.		Correctly wire r1/ℓ11, $\phi$ 1/ℓ21, and t1/ℓ31.		
Digital Operator Display		Minor Fault Name	Detail	Alarm Output (H2-□□=10)
<i>bb</i>	bb	Baseblock	converter output interrupted as indicated by an external baseblock signal.	N.A.
<b>Cause</b>		<b>Possible Solutions</b>		
External baseblock signal was entered via one of the multi-function input terminals (S1 to S8).		Check external sequence and baseblock signal input timing.		



Digital Operator Display		Minor Fault Name	Detail	Alarm Output (H2-□□=10)
bUS	bUS	Option Communication Error	<ul style="list-style-type: none"> <li>The connection was lost after initial communication was established.</li> <li>Assign a Run command frequency reference to the option.</li> </ul>	YES
<b>Cause</b>		<b>Possible Solutions</b>		
Connection is broken or master controller stopped communicating.		<ul style="list-style-type: none"> <li>Check for faulty wiring.</li> <li>Correct the wiring.</li> <li>Check for disconnected cables and short circuits. Repair as needed.</li> </ul>		
Option is damaged.		If there are no problems with the wiring and the fault continues to occur, replace the option.		
The option is not properly connected to the converter.		<ul style="list-style-type: none"> <li>The connector pins on the option are not properly lined up with the connector pins on the converter.</li> <li>Reinstall the option.</li> </ul>		
A data error occurred due to noise.		<ul style="list-style-type: none"> <li>Check options available to minimize the effects of noise.</li> <li>Take steps to counteract noise in the control circuit wiring, main circuit lines and ground wiring.</li> <li>Try to reduce noise on the controller side.</li> <li>Use surge absorbers on magnetic contactors or other equipment causing the disturbance.</li> <li>Use recommended cables or some other type of shielded line. Ground the shield to the controller side or on the input power side.</li> <li>Separate the wiring for communication devices from the converter input power lines. Install an EMC noise filter to the converter input power.</li> </ul>		
Digital Operator Display		Minor Fault Name	Detail	Alarm Output (H2-□□=10)
CALL	CALL	Serial Communication Transmission Error	Communication has not yet been established.	YES
<b>Cause</b>		<b>Possible Solutions</b>		
Communications wiring is faulty, there is a short circuit, or something is not connected properly.		<ul style="list-style-type: none"> <li>Check for wiring errors.</li> <li>Correct the wiring.</li> <li>Check for disconnected cables and short circuits. Repair as needed.</li> </ul>		
Programming error on the master side.		Check communications at start-up and correct programming errors.		
Communications circuitry is damaged.		<ul style="list-style-type: none"> <li>Perform a self-diagnostics check.</li> <li>If the problem continues, replace either the control board or the entire converter. For instructions on replacing the control board, contact Yaskawa or your nearest sales representative.</li> </ul>		
Termination resistor setting is incorrect.		Install a termination resistor at both ends of a communication line. Set the internal termination resistor switch correctly on slave converters. Place DIP switch S2 to the ON position.		
Digital Operator Display		Minor Fault Name	Detail	Alarm Output (H2-□□=10)
CE	CE	MEMOBUS/Modbus Communication Error	Control data was not received correctly for two seconds.	YES
<b>Cause</b>		<b>Possible Solutions</b>		
A data error occurred due to noise.		<ul style="list-style-type: none"> <li>Check options available to minimize the effects of noise.</li> <li>Take steps to counteract noise in the control circuit wiring, main circuit lines, and ground wiring.</li> <li>Reduce noise on the controller side.</li> <li>Use surge absorbers for the magnetic contactors or other components that may be causing the disturbance.</li> <li>Use only recommended shielded line. Ground the shield on the controller side or on the converter input power side.</li> <li>Separate all wiring for communication devices from converter input power lines. Install an EMC noise filter to the converter input power supply.</li> </ul>		
Communication protocol is incompatible.		<ul style="list-style-type: none"> <li>Check the H5 parameter settings and the protocol setting in the controller.</li> <li>Ensure settings are compatible.</li> </ul>		
The CE detection time (H5-09) is set shorter than the time required for a communication cycle to take place.		<ul style="list-style-type: none"> <li>Check the PLC.</li> <li>Change the software settings in the PLC.</li> <li>Set a longer CE detection time using parameter H5-09.</li> </ul>		

## 5.4 Alarm Detection

Incompatible PLC software settings or there is a hardware problem.		<ul style="list-style-type: none"> <li>• Check the PLC.</li> <li>• Remove the cause of the error on the controller side.</li> </ul>	
Communications cable is disconnected or damaged.		<ul style="list-style-type: none"> <li>• Check the connector to make sure the cable has a signal.</li> <li>• Replace the communications cable.</li> </ul>	
Digital Operator Display	Minor Fault Name	Detail	Alarm Output (H2-□□=10)
CoF	CoF	Current Offset Fault	YES
<b>Cause</b>		<b>Possible Solutions</b>	
A fault occurred in the current detection circuit.		Cycle the power supply and check operation. <ul style="list-style-type: none"> <li>• If the fault occurs again, replace the board or converter. For information on board replacement, consult with your Yaskawa representative or the nearest Yaskawa sales office.</li> </ul>	
Digital Operator Display	Minor Fault Name	Detail	Alarm Output (H2-□□=10)
CrST	CrST	Cannot Reset	YES
<b>Cause</b>		<b>Possible Solutions</b>	
Fault reset was being executed when a Run command was entered.		<ul style="list-style-type: none"> <li>• Ensure that a Run command cannot be entered from the external terminals or option during fault reset.</li> <li>• Turn off the Run command.</li> </ul>	
Digital Operator Display	Minor Fault Name	Detail	Alarm Output (H2-□□=10)
CyC	CyC	MECHATROLINK Communications Cycle Setting Error	YES
<b>Cause</b>		<b>Possible Solutions</b>	
The communications cycle of the MECHATROLINK option card is out of range.		Correct the setting.	
Digital Operator Display	Minor Fault Name	Detail	Alarm Output (H2-□□=10)
E5	E5	MECHATROLINK Watchdog Timer Error	YES
<b>Cause</b>		<b>Possible Solutions</b>	
There is no continuity in the watchdog timer in the data that is sent by the host controller.		Execute the DISCONNECT or ALM_CLR command, and then move to phase 3 again with the CONNECT or SYNC_SET command.	
Digital Operator Display	Minor Fault Name	Detail	Alarm Output (H2-□□=10)
EF0	EF0	Option Card External Fault	YES
<b>Cause</b>		<b>Possible Solutions</b>	
An external fault was received from the PLC with F6-03 set to 3, which allows the converter to continue running after an external fault occurs.		<ul style="list-style-type: none"> <li>• Remove the cause of the external fault.</li> <li>• Remove the external fault input from the PLC.</li> </ul>	
There is a problem with the PLC program.		Check the PLC program and correct problems.	

Digital Operator Display		Minor Fault Name	Detail	Alarm Output (H2-□□=10)
<i>EF1</i>	EF1	External Fault (Input Terminal S1)	External fault at multi-function input terminal S1.	YES
<i>EF2</i>	EF2	External fault (input terminal S2)	External fault at multi-function input terminal S2.	
<i>EF3</i>	EF3	External fault (input terminal S3)	External fault at multi-function input terminal S3.	
<i>EF4</i>	EF4	External fault (input terminal S4)	External fault at multi-function input terminal S4.	
<i>EF5</i>	EF5	External fault (input terminal S5)	External fault at multi-function input terminal S5.	
<i>EF6</i>	EF6	External fault (input terminal S6)	External fault at multi-function input terminal S6.	
<i>EF7</i>	EF7	External fault (input terminal S7)	External fault at multi-function input terminal S7.	
<i>EF8</i>	EF8	External fault (input terminal S8)	External fault at multi-function input terminal S8.	
<b>Cause</b>		<b>Possible Solutions</b>		
An external device has tripped an alarm function.		Remove the cause of the external fault and reset the multi-function input value. Refer to <i>Stopping the Converter for Faults in Peripheral Devices on page 98</i> for details.		
Wiring is incorrect.		<ul style="list-style-type: none"> <li>Ensure the signal lines have been connected properly to the terminals assigned for external fault detection (H1-□□ = 24 to 27, 2C to 2F).</li> <li>Reconnect the signal line. Refer to <i>Stopping the Converter for Faults in Peripheral Devices on page 98</i> for details.</li> </ul>		
Multi-function contact inputs are set incorrectly.		<ul style="list-style-type: none"> <li>Check if the unused terminals have been set for H1-□□ = 24 to 27, 2C to 2F (External Fault).</li> <li>Change the terminal settings. Refer to <i>Stopping the Converter for Faults in Peripheral Devices on page 98</i> for details.</li> </ul>		
Digital Operator Display		Minor Fault Name	Detail	Alarm Output (H2-□□=10)
<i>FAn</i>	Fan	Converter Internal Circulation Fan Fault	The internal circulation fan in the converter is faulty.	YES
<b>Cause</b>		<b>Possible Solutions</b>		
An internal circulation fan is faulty (2A0130 or 4A0130 to 4A0370).		Cycle the power supply and see if the fault occurs again. Check the operation of the internal circulation fans. Check U4-03 (Cooling Fan Operation Time) and U4-04 (Cooling Fan Maintenance Display). <ul style="list-style-type: none"> <li>If the life of the internal circulation fans has expired or if a fan is faulty, perform fan replacement according to instructions in this manual.</li> </ul>		
An internal circulation fan or MC power supply is faulty (2A0130 or 4A0130 to 4A0370).		Cycle the power supply and see if the fault occurs again. <ul style="list-style-type: none"> <li>If the fault occurs repeatedly, replace the board or the converter. For information on board replacement, consult with your Yaskawa representative or the nearest Yaskawa sales office.</li> </ul>		
Digital Operator Display		Minor Fault Name	Detail	Alarm Output (H2-□□=10)
<i>Fdv</i>	Fdv	Power Supply Frequency Fault	The input power supply frequency exceeded the allowable frequency fluctuation.	YES
<b>Cause</b>		<b>Possible Solutions</b>		
A momentary power loss occurred.		Investigate and correct the cause and reset the fault. Refer to <i>Diagnosing and Resetting Faults on page 131</i> .		
An input power supply wiring terminal is loose.				
The fluctuation in the voltage of the input power supply is too large.				
The AC power supply fuse is open.		<ul style="list-style-type: none"> <li>A transistor inside the converter was destroyed.</li> <li>The input wiring or drive output has ground faulted or short circuited.</li> </ul> Contact your Yaskawa representative or the nearest Yaskawa sales office.		

## 5.4 Alarm Detection

The phase rotation direction has changed in the input power supply.		Correct the wiring.	
The detected power supply frequency exceeded the allowable value.		Improve the power supply.	
Digital Operator Display	Minor Fault Name	Detail	Alarm Output (H2-□□=10)
HER	HCA	Current Alarm	YES
<b>Cause</b>		<b>Possible Solutions</b>	
Load is too heavy.		Reduce the load for applications with repetitive operations (i.e., stops and starts), or replace the converter.	
Digital Operator Display	Minor Fault Name	Detail	Alarm Output (H2-□□=10)
LF-1	LT-1	Cooling Fan Maintenance Time	YES
<b>Cause</b>		<b>Possible Solutions</b>	
The cooling fan has reached 90% of its expected performance life.		Replace the cooling fan and set o4-03 to 0 to reset the Maintenance Monitor.	
Digital Operator Display	Minor Fault Name	Detail	Alarm Output (H2-□□=10)
LF-2	LT-2	Capacitor Maintenance Time	YES
<b>Cause</b>		<b>Possible Solutions</b>	
The main circuit and control circuit capacitors have reached 90% of their expected performance lives.		Replace either the control board or the entire converter. For instructions on replacing the control board, contact Yaskawa or your nearest sales representative.	
Digital Operator Display	Minor Fault Name	Detail	Alarm Output (H2-□□=10)
LF-3	LT-3	Soft Charge Bypass Relay Maintenance Time	YES
<b>Cause</b>		<b>Possible Solutions</b>	
The DC bus soft charge relay has reached 90% of expected performance life.		Replace either the control board or the entire converter. For instructions on replacing the control board, contact Yaskawa or your nearest sales representative.	
Digital Operator Display	Minor Fault Name	Detail	Alarm Output (H2-□□=10)
oH	oH	Heatsink Overheat	YES
<b>Cause</b>		<b>Possible Solutions</b>	
Surrounding temperature is too high		<ul style="list-style-type: none"> <li>• Check the surrounding temperature.</li> <li>• Improve the air circulation within the enclosure panel.</li> <li>• Install a fan or air conditioner to cool surrounding area.</li> <li>• Remove anything near converter that may cause extra heat.</li> </ul>	
Airflow around the converter is restricted.		<ul style="list-style-type: none"> <li>• Provide proper installation space around the converter as indicated in the manual. Refer to <a href="#">Installation Orientation and Spacing on page 30</a> for details.</li> <li>• Allow for the proper space and ensure that there is sufficient circulation around the control panel.</li> </ul>	
		<ul style="list-style-type: none"> <li>• Check for dust or other foreign materials clogging the cooling fan.</li> <li>• Clear debris caught in the fan that restricts air circulation.</li> </ul>	

The ambient temperature is too high.		Check the ambient temperature. <ul style="list-style-type: none"> <li>• Improve ventilation in the control panel.</li> <li>• Install a cooling device (e.g., a cooling fan or air conditioner) and lower the ambient temperature.</li> <li>• If there are heat-generating objects nearby, remove them.</li> </ul>		
The load is too large.		Measure the output current. Lower the load.		
Internal cooling fan has stopped.		<ul style="list-style-type: none"> <li>• Replace the cooling fan. Refer to page 141 for details.</li> <li>• After replacing the converter, set parameter o4-03 to 0 to reset the cooling fan operation time.</li> </ul>		
Digital Operator Display		Minor Fault Name	Detail	Alarm Output (H2-□□=10)
oL2	oL2	Converter Overload	The thermal sensor of the converter triggered the converter overload protection.	YES
<b>Cause</b>		<b>Possible Solutions</b>		
Load is too heavy.		Reduce the load.		
The converter does not operate.		Start converter operation first, and then start converter operation.		
Digital Operator Display		Minor Fault Name	Detail	Alarm Output (H2-□□=10)
ou	ov	DC Bus Overvoltage	The DC bus voltage exceeded the trip point. <ul style="list-style-type: none"> <li>• 200 V Class: Approximately 410 V</li> <li>• 400 V Class: Approximately 820 V</li> </ul>	YES
<b>Cause</b>		<b>Possible Solutions</b>		
Electrical noise interference causes the converter to operate incorrectly.		<ul style="list-style-type: none"> <li>• Review possible solutions for handling noise interference.</li> <li>• Review section on handling noise interference and check control circuit lines, main circuit lines and ground wiring.</li> <li>• If the magnetic contactor is identified as a source of noise, install a surge protector to the MC coil.</li> </ul>		
		Set number of fault restarts (L5-01) to a value other than 0.		
There was a regenerative load while the converter is stopped.		Operate the converter.		
The power supply voltage is too high.		Lower the voltage so that it is within the power supply specifications of the converter.		
There is a regenerative load while the converter is stopped.		Operate the converter.		
The wiring of the power supply voltage detection circuits (r1/l11, a1/l21, t1/l31) and the wiring of the main circuit terminals (R/L1, S/L2, and T/L3) is not correct.		Check the wiring. Correct the wiring.		
Digital Operator Display		Minor Fault Name	Detail	Alarm Output (H2-□□=10)
PAUv	PAUv	Power Supply Undervoltage Pre-Alarm	The input power supply voltage became equal to or lower than the Input Power Supply Undervoltage Detection Level. <ul style="list-style-type: none"> <li>200 V Class: Approximately 150 Vac</li> <li>400 V Class: Approximately 300 Vac</li> </ul> The converter enters the baseblock state during pre-alarm. When the input supply voltage is restored during the pre-alarm, the converter will release the base block and continue to operate.	YES
<b>Cause</b>		<b>Possible Solutions</b>		
The power supply voltage is low.		Increase the power supply voltage.		
A phase loss occurred in the input power supply.		Check the input power supply for phase loss or an imbalance in the interphase voltages. Investigate and correct the cause and reset the fault.		
Voltage detection failed.		Check r1/l11, a1/l21, t1/l31 to see if they are wired correctly.		

## 5.4 Alarm Detection

Digital Operator Display		Minor Fault Name	Detail	Alarm Output (H2-□□=10)
PF3	PF3	Input Phase Loss Detection	Abnormal oscillation continued in the input power supply voltage. (Detected when L8-69 = 1.)	YES
<b>Cause</b>		<b>Possible Solutions</b>		
The fluctuation in the voltage of the input power supply is too large.		Investigate the cause and implement countermeasures. Refer to <i>Diagnosing and Resetting Faults on page 131</i> for details.		
A phase loss occurred in the input power supply.				
The interphase voltage balance is bad.				
Digital Operator Display		Minor Fault Name	Detail	Alarm Output (H2-□□=10)
SE	SE	MEMOBUS/Modbus Test Mode Fault	A MEMOBUS/Modbus communications test was performed during operation.	YES
<b>Cause</b>		<b>Possible Solutions</b>		
A fault occurred during MEMOBUS/Modbus Communications Test Mode.		Always stop the operation of the converter before you perform MEMOBUS/Modbus communications tests.		
Digital Operator Display		Minor Fault Name	Detail	Alarm Output (H2-□□=10)
SrC	SrC	Phase Order Fault	The phase order detection direction for the input power supply changed after the power supply was turned on.	YES
<b>Cause</b>		<b>Possible Solutions</b>		
A momentary power loss occurred.		Investigate and correct the cause and reset the fault. Refer to <i>Diagnosing and Resetting Faults on page 131</i> for details.		
An input power supply wiring terminal is loose.				
The fluctuation in the voltage of the input power supply is too large.				
Digital Operator Display		Minor Fault Name	Detail	Alarm Output (H2-□□=10)
Uv	Uv	Undervoltage	One of the following conditions was true when the converter was stopped and a Run command was entered: <ul style="list-style-type: none"> <li>DC bus voltage dropped below the level specified in L2-05.</li> <li>Contactors to suppress inrush current in the converter were opened.</li> <li>Low voltage in the control converter input power. This alarm outputs only if L2-01 is not 0 and DC bus voltage is under L2-05.</li> </ul>	YES
<b>Cause</b>		<b>Possible Solutions</b>		
Phase loss in the converter input power.		Check for wiring errors in the main circuit input power. Correct the wiring.		
Loose wiring in the converter input power terminals.		<ul style="list-style-type: none"> <li>Ensure the terminals have been properly tightened.</li> <li>Apply the tightening torque to the terminals as specified. Refer to <i>Wire Gauges and Tightening Torque on page 62</i>.</li> </ul>		
There is a problem with the converter input power voltage.		<ul style="list-style-type: none"> <li>Check the voltage.</li> <li>Lower the voltage of the converter input power so that it is within the limits listed in the specifications.</li> </ul>		
A power loss occurred.		Improve the power supply.		
Internal circuitry is worn.		<ul style="list-style-type: none"> <li>Check the maintenance time for the capacitors (U4-05).</li> <li>Replace either the control board or the entire converter if U4-05 exceeds 90%. For instructions on replacing the control board, contact Yaskawa or your nearest sales representative.</li> </ul>		
The converter input power transformer is too small and voltage drops when the power is switched on.		<ul style="list-style-type: none"> <li>Check for an alarm when the magnetic contactor, line breaker, and leakage breaker are closed.</li> <li>Check the capacity of the converter input power transformer.</li> </ul>		
Air inside the converter is too hot.		Check the temperature inside the converter.		
The CHARGE light is broken or disconnected.		Replace either the control board or the entire converter. For instructions on replacing the control board, contact Yaskawa or your nearest sales representative.		

Digital Operator Display		Minor Fault Name	Detail	Alarm Output (H2-□□=10)
urE	vrE	Resonance Detection	A filter resonance fault was detected or there is a harmonic component on the power supply side.	YES
<b>Cause</b>			<b>Possible Solutions</b>	
There is noise on the power supply line.			Investigate the source of the noise and implement countermeasures.	

## 5.5 Operator Programming Errors

### ◆ Operator Programming Error Codes, Causes, and Possible Solutions

An Operator Programming Error (oPE) occurs when a contradictory parameter is set or an individual parameter is set to an inappropriate value.

The converter will not operate until the parameter or parameters causing the problem are set correctly. An oPE, however, does not trigger an alarm or fault output. If an oPE occurs, investigate the cause and refer to [Table 5.8](#) for the appropriate action. When an oPE appears on the operator display, press the ENTER button to view U1-18 and see which parameter is causing the oPE.

**Table 5.8 oPE Codes, Causes, and Possible Solutions**

Digital Operator Display		Error Name	Detail
Err	Err	EEPROM Write Error	A verification mismatch occurred when writing data to the EEPROM.
<b>Cause</b>		<b>Possible Solutions</b>	
The data was corrupted by noise when writing data to the EEPROM.		<ul style="list-style-type: none"> <li>Press .</li> <li>Set the parameters again.</li> <li>Cycle the power supply. Refer to <a href="#">Diagnosing and Resetting Faults on page 131</a> for details.</li> </ul>	
EEPROM Hardware Failure		Replace the board or converter. For information on board replacement, consult with your Yaskawa representative or the nearest Yaskawa sales office.	
Digital Operator Display		Error Name	Detail
oPE01	oPE01	Converter Capacity Setting Fault	Converter capacity and the value set to o2-04 do not match.
<b>Cause</b>		<b>Possible Solutions</b>	
The drive model selection (o2-04) and the actual capacity of the converter are not the same.		Correct the value set to o2-04.	
Digital Operator Display		Error Name	Detail
oPE02	oPE02	Parameter Range Setting Error	Use U1-18 to find parameters set outside the range.
<b>Cause</b>		<b>Possible Solutions</b>	
Parameters were set outside the possible setting range.		Set parameters to the proper values.	
<b>Note:</b> When multiple errors occur simultaneously, other errors are given precedence over oPE02.			
Digital Operator Display		Error Name	Detail
oPE03	oPE03	Multi-Function Input Selection Error	A contradictory setting is assigned to multi-function contact inputs H1-01 to H1-08.
<b>Cause</b>		<b>Possible Solutions</b>	
The same function is assigned to two multi-function inputs. Excludes “Not used” and “External Fault.”		<ul style="list-style-type: none"> <li>Ensure all multi-function inputs are assigned to different functions.</li> <li>Re-enter the multi-function settings to ensure this does not occur.</li> </ul>	



Digital Operator Display		Error Name	Detail
oPE04	oPE04	Terminal Board Mismatch Error	The converter or the removable terminal block with parameter backup was replaced.
<b>Cause</b>		<b>Possible Solutions</b>	
The converter was replaced (but the removable terminal block with parameter backup was not replaced).		Set A1-03 to 5550 to load the parameter settings stored in the terminal board to the converter. Initialize parameters after converter replacement by setting A1-03 to 2220.	
The removable terminal block with parameter backup was replaced.			
Digital Operator Display		Error Name	Detail
oPE05	oPE05	Run Command Selection Error	The settings for the Run Command or Bus Voltage Command are not correct.
<b>Cause</b>		<b>Possible Solutions</b>	
The Run command is assigned to an option card (b1-18 = 3) and an input option card is not connected to the converter.		Reconnect the input option card to the converter.	
The Run command is assigned to an option card (b1-02 = 3) and an input option card is not connected to the converter.			
Digital Operator Display		Error Name	Detail
oPE07	oPE07	Multi-Function Analog Input Selection Error	A contradictory setting is assigned to multi-function analog inputs H3-02, H3-10, or H3-06.
<b>Cause</b>		<b>Possible Solutions</b>	
At least two of these parameters have the same setting: H3-02, H3-10, or H3-06.		Change the settings to H3-02, H3-10, and H3-06 so that functions no longer conflict. <b>Note:</b> Both 1F (Through mode) and F (Through mode) can be set to H3-02, H3-10, or H3-06 simultaneously.	
Digital Operator Display		Error Name	Detail
oPE30	oPE30	Incorrect Input Voltage Adjustment	The input voltage offset adjustment has not been performed.
<b>Cause</b>		<b>Possible Solutions</b>	
<ul style="list-style-type: none"> <li>The setting of o2-04 (Drive Model Selection) changed.</li> <li>ERPROM failed for the input voltage offset.</li> </ul>		For information on clearing the fault, consult with your Yaskawa representative or the nearest Yaskawa sales office.	

## 5.6 Copy Function Related Displays

### ◆ Tasks, Errors, and Troubleshooting

The table below lists the messages and errors that may appear when using the Copy function. When executing the tasks offered by the Copy function, the operator will indicate the task being performed. When an error occurs, a code appears on the operator to indicate the error. Note that errors related to the Copy function do not trigger a multifunction output terminal that has been set up to close when a fault or alarm occurs. To clear an error, simply press any key on the operator and the error display will disappear.

*Table 5.9* lists the corrective action that can be taken when an error occurs.

- Note:**
1. Whenever using the copy function, the converter should be fully stopped.
  2. The converter will not accept a Run command while the Copy function is being executed.
  3. Parameters can only be saved to a converter when the voltage class, capacity, control mode, and software version match.

**Table 5.9 Copy Function Task and Error Displays**

Digital Operator Display		Error Name
<i>CoPY</i>	CoPy	Writing Parameter Settings (flashing)
<i>CPyE</i>	CPyE	Error Writing Data
<i>CSEr</i>	CSEr	Copy Unit Error
<i>dFPS</i>	dFPS	Model Mismatch
<i>End</i>	End	Task Complete
<i>iFEr</i>	iFEr	Communication Error
<i>ndAT</i>	ndAT	Model, Voltage Class, Capacity Mismatch
<i>rdEr</i>	rdEr	Error Reading Data
<i>rEAd</i>	rEAd	Reading Parameter Settings (flashing)
<i>vAEr</i>	vAEr	Voltage Class, Capacity Mismatch
<i>vFyE</i>	vFyE	Parameter settings in the converter and those saved to the copy function are not the same
<i>vrFy</i>	vrFy	Comparing Parameter Settings (flashing)

## 5.7 Diagnosing and Resetting Faults

When a fault occurs and the converter stops, follow the instructions below to remove whatever conditions triggered the fault, then restart the converter.

### ◆ Fault Reset Methods

When a fault occurs, the cause of the fault must be removed and the converter must be restarted. The table below lists the different ways to restart the converter.

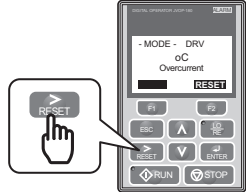
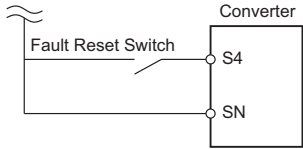
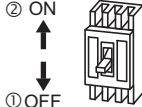
After the Fault Occurs	Procedure	
Fix the cause of the fault, restart the converter, and reset the fault	Press  on the digital operator when the error code is displayed.	
Resetting via Fault Reset Digital Input S4	Close then open the fault signal digital input via terminal S4. S4 is set for "Fault Reset" as default (H1-04 = 14).	
Turn off the main power supply if the above methods do not reset the fault. Reapply power after the digital operator display has turned off.		

**Note:** If the Run command is present, the converter will disregard any attempts to reset the fault. Remove the Run command before attempting to clear a fault situation.



## Periodic Inspection & Maintenance

---

This chapter describes the periodic inspection and maintenance of the converter to ensure that it receives the proper care to maintain overall performance.

<b>6.1</b>	<b>SECTION SAFETY</b> .....	<b>134</b>
<b>6.2</b>	<b>INSPECTION</b> .....	<b>136</b>
<b>6.3</b>	<b>PERIODIC MAINTENANCE</b> .....	<b>139</b>
<b>6.4</b>	<b>COOLING FANS</b> .....	<b>141</b>
<b>6.5</b>	<b>CONVERTER REPLACEMENT</b> .....	<b>160</b>

## 6.1 Section Safety

### WARNING

#### Electrical Shock Hazard

**Do not connect or disconnect wiring while the power is on.**

Failure to comply could result in death or serious injury.

Before servicing, disconnect all power to the equipment. The internal capacitor remains charged even after the power supply is turned off. The charge indicator LED will extinguish when the DC bus voltage is below 50 Vdc. To prevent electric shock, wait for at least the time specified on the warning label; after all indicators are OFF, measure for unsafe voltages to confirm the converter is safe prior to servicing.

**Do not operate equipment with covers removed.**

Failure to comply could result in death or serious injury.

The diagrams in this section may show converter without covers or safety shields to show details. Be sure to reinstall covers or shields before operating the converter and run the converter according to the instructions described in this manual.

**Do not remove covers or touch circuit boards while the power is on.**

Failure to comply could result in death or serious injury.

**Do not allow unqualified personnel to perform work on the converter.**

Failure to comply could result in death or serious injury.

Installation, maintenance, inspection, and servicing must be performed only by authorized personnel familiar with installation, adjustment, and maintenance of this equipment.

**Do not perform work on the converter while wearing loose clothing, jewelry or without eye protection.**

Failure to comply could result in death or serious injury.

Remove all metal objects such as watches and rings, secure loose clothing, and wear eye protection before beginning work on the converter.

**Do not touch any terminals before the capacitors have fully discharged.**

Failure to comply could result in death or serious injury.

Before servicing, disconnect all power to the equipment. The internal capacitor remains charged even after the power supply is turned off. The charge indicator LED will extinguish when the DC bus voltage is below 50 Vdc. To prevent electric shock, wait for at least the time specified on the warning label; after all indicators are OFF, measure the voltage level to confirm it has reached a safe level.

#### Fire Hazard

**Tighten all terminal screws to the specified tightening torque.**

Loose electrical connections could result in death or serious injury by fire due to overheating of electrical connections.

**Do not use an improper voltage source.**

Failure to comply could result in death or serious injury by fire.

Verify that the rated voltage of the converter matches the voltage of the incoming power supply before applying power.

**Do not use improper combustible materials.**

Failure to comply could result in death or serious injury by fire.

Attach the converter to metal or other noncombustible material.

**NOTICE****Observe proper electrostatic discharge procedures (ESD) when handling the converter and circuit boards.**

Failure to comply may result in ESD damage to the converter circuitry.

**Follow cooling fan replacement instructions. The cooling fan cannot operate properly when it is installed incorrectly and could seriously damage the converter.**

Follow the instructions in this manual to replace the cooling fan, making sure that the label is on top before inserting the cooling fan into the converter. To ensure maximum useful product life, replace all cooling fans when performing maintenance.

**Do not use unshielded cable for control wiring.**

Failure to comply may cause electrical interference resulting in poor system performance. Use shielded, twisted-pair wires and ground the shield to the shield ground terminal E (G) of the converter.

**Do not modify the converter circuitry.**

Failure to comply could result in damage to the converter and will void warranty.

Yaskawa is not responsible for any modification of the product made by the user. This product must not be modified.

**Check all the wiring to ensure that all connections are correct after installing the converter and connecting any other devices.**

Failure to comply could result in damage to the converter.

**Frequently switching the converter power supply on and off can damage the converter.**

To get the full performance life out of the electrolytic capacitors and circuit relays, refrain from switching the converter power supply off and on more than once every 30 minutes.

**Do not operate damaged equipment.**

Failure to comply could result in further damage to the equipment.

Do not connect or operate any equipment with visible damage or missing parts.

# 6.2 Inspection

Power electronics have limited life and may exhibit changes in characteristics or performance deterioration after years of use under normal conditions. To help avoid such problems, it is important to perform preventive maintenance and periodic inspection on the converter.

Converters contain a variety of power electronics such as power transistors, semiconductors, capacitors, resistors, fans, and relays. The electronics in the converter serve a critical role in maintaining proper motor control.

Follow the inspection lists provided in this chapter as a part of a regular maintenance program.

**Note:** The converter will require more frequent inspection if it is placed in harsh environments, such as:

- High ambient temperatures
- Frequent starting and stopping
- Fluctuations in the AC supply or load
- Excessive vibrations or shock loading
- Dust, metal dust, salt, sulfuric acid, chlorine atmospheres
- Poor storage conditions

Perform the first equipment inspection one to two years after installation.

### ◆ Recommended Daily Inspection

*Table 6.1* outlines the recommended daily inspection for the Yaskawa converter. Check the following items on a daily basis to avoid premature deterioration in performance or product failure. Copy this checklist and mark the “Checked” column after each inspection.

**NOTICE:** Check the operation of the cooling fan only during inspections.

**Table 6.1 General Recommended Daily Inspection Checklist**

Inspection Category	Inspection Points	Corrective Action	Checked
Cooling	Inspect for abnormal heat generated from the converter and visible discoloration.	Check for the following: <ul style="list-style-type: none"> <li>• Excessive load.</li> <li>• Dirty heatsink.</li> <li>• Tighten all loose screws.</li> <li>• Ambient temperature.</li> </ul>	
	Inspect converter cooling fan and circulation fan operation	Check for the following: <ul style="list-style-type: none"> <li>• Clogged or dirty fan.</li> <li>• Correct Fan operation parameter setting. Refer to <i>o: Operator-Related Settings on page 193</i> for details.</li> </ul>	
Environment	Verify the converter environment complies with the specifications listed in <i>Installation Environment on page 29</i> .	Eliminate the source of contaminants or correct poor environment.	
Power Supply Voltage	Check main power supply and control voltages.	<ul style="list-style-type: none"> <li>• Correct the voltage or power supply to within nameplate specifications.</li> <li>• Verify all main circuit phases.</li> </ul>	



## ◆ Recommended Periodic Inspection

*Table 6.2* outlines the recommended periodic inspections for Yaskawa converter installations. Although periodic inspections should generally be performed once a year, the converter may require more frequent inspection in harsh environments or with rigorous use. Operating and environmental conditions, along with experience in each application, will determine the actual inspection frequency for each installation. Periodic inspection will help to avoid premature deterioration in performance or product failure. Copy this checklist and mark the “Checked” column after each inspection.

### ■ Periodic Inspection

**DANGER!** *Electrical Shock Hazard. Do not inspect, connect, or disconnect any wiring while the power is on. Failure to comply can result in serious personal injury. Before servicing, disconnect all power to the equipment. The internal capacitor remains charged even after the power supply is turned off. The charge indicator LED will extinguish when the DC bus voltage is below 50 Vdc. To prevent electric shock, wait for at least the time specified on the warning label; after all indicators are OFF, measure for unsafe voltages to confirm the converter is safe prior to servicing.*

**NOTICE:** *Check the operation of the cooling fan only during inspections.*

**Table 6.2 Periodic Inspection Checklist**

Inspection Area	Inspection Points	Corrective Action	Checked
<b>Main Circuit Periodic Inspection</b>			
<b>General</b>	<ul style="list-style-type: none"> <li>Inspect equipment for discoloration from overheating or deterioration.</li> <li>Inspect for damaged or deformed parts.</li> </ul>	<ul style="list-style-type: none"> <li>Replace damaged components as required.</li> <li>The converter has few serviceable parts and may require complete converter replacement.</li> </ul>	
	Inspect for dirt, foreign particles, or dust collection on components.	<ul style="list-style-type: none"> <li>Inspect enclosure door seal if used.</li> <li>Use a vacuum cleaner to remove dust and dirt, but do not allow it to come into contact with product components.</li> <li>Replace components if cleaning is not possible.</li> </ul>	
<b>Conductors and Wiring</b>	<ul style="list-style-type: none"> <li>Inspect wiring and connections for discoloration, damage, or heat stress.</li> <li>Inspect wire insulation and shielding for wear.</li> </ul>	Repair or replace damaged wiring.	
<b>Terminals</b>	Inspect terminals for stripped, damaged, or loose connections.	Tighten loose screws and replace damaged screws or terminals.	
<b>Relays and Contactors</b>	<ul style="list-style-type: none"> <li>Inspect contactors and relays for excessive noise during operation.</li> <li>Inspect coils for signs of overheating such as melted or cracked insulation.</li> </ul>	<ul style="list-style-type: none"> <li>Check coil voltage for overvoltage or undervoltage conditions.</li> <li>Replace damaged removable relays, contactors, or circuit board.</li> </ul>	
<b>Electrolytic Capacitor</b>	<ul style="list-style-type: none"> <li>Inspect for leaking, discoloration, or cracks.</li> <li>Check if the cap has come off, for any swelling, or if the sides have burst open.</li> </ul>	The converter has few serviceable parts and may require complete converter replacement.	
<b>Diode, IGBT (Power Transistor)</b>	Inspect for dust or other foreign material collected on the surface.	Use a vacuum cleaner to remove dust and dirt, but do not allow it to come into contact with product components.	
<b>Control Circuit Periodic Inspection</b>			
<b>General</b>	<ul style="list-style-type: none"> <li>Inspect terminals for stripped, damaged, or loose connections.</li> <li>Make sure all terminals have been properly tightened.</li> </ul>	<ul style="list-style-type: none"> <li>Tighten loose screws and replace damaged screws or terminals.</li> <li>If terminals are integral to a circuit board, then board or converter replacement may be required.</li> </ul>	
<b>Circuit Boards</b>	Check for any odor, discoloration, and rust. Make sure connections are properly fastened and that no dust or oil mist has accumulated on the surface of the board.	<ul style="list-style-type: none"> <li>Fix any loose connections.</li> <li>If an antistatic cloth or vacuum plunger cannot be used, replace the board.</li> <li>Use a vacuum cleaner to remove dust and dirt, but do not allow it to come into contact with product components.</li> <li>Do not use any solvents to clean the board.</li> <li>The converter has few serviceable parts and may require complete converter replacement.</li> </ul>	

## 6.2 Inspection

Inspection Area	Inspection Points	Corrective Action	Checked
<b>Cooling System Periodic Inspection</b>			
<b>Cooling Fan, Circulation Fan, Control Board Cooling Fan</b>	<ul style="list-style-type: none"> <li>• Check for abnormal oscillation or unusual noise.</li> <li>• Check for damaged or missing fan blades.</li> </ul>	<ul style="list-style-type: none"> <li>• Replace as required.</li> <li>• <i>Cooling Fans on page 141</i> for information on cleaning or replacing the fan.</li> </ul>	
<b>Heatsink</b>	Inspect for dust or other foreign material collected on the surface.	Use a vacuum cleaner to remove dust and dirt, but do not allow it to come into contact with product components.	
<b>Display Periodic Inspection</b>			
<b>Digital Operator</b>	<ul style="list-style-type: none"> <li>• Make sure data appears on the display properly.</li> <li>• Inspect for dust or other foreign material that may have collected on surrounding components.</li> </ul>	<ul style="list-style-type: none"> <li>• Contact the nearest sales office if there is any trouble with the display or keypad.</li> <li>• Clean the digital operator.</li> </ul>	

## 6.3 Periodic Maintenance

The converter has Maintenance Monitors that keep track of component wear. This feature provides advance maintenance warning and eliminates the need to shut down the entire system for unexpected problems. The converter allows the user to check predicted maintenance periods for the components listed below.

- Cooling Fan, Circulation Fan, Control Board Cooling Fan
- Electrolytic Capacitors
- Inrush Prevention Circuit

For replacement parts, contact the distributor where the converter was purchased or contact Yaskawa directly.

### ◆ Replacement Parts

**Table 6.3** contains the estimated performance life of components that require replacement during the life of the converter. Only use Yaskawa replacement parts for the appropriate model and revision.

**Table 6.3 Estimated Performance Life**

Component	Estimated Performance Life
Cooling Fan, Circulation, Control Board Cooling Fan	10 years
Electrolytic Capacitors	10 years <1>
Fuse	10 years

<1> The converter has few serviceable parts and may require complete converter replacement.

**NOTICE:** Estimated performance life based on specific usage conditions. These conditions are provided for the purpose of replacing parts to maintain performance. Some parts may require more frequent replacement due to poor environments or rigorous use.

Usage conditions for estimated performance life:

Ambient temperature: Yearly average of 40°C (IP00/Open Type enclosure)

Load factor: 80% maximum

Operation time: 24 hours a day

**NOTICE:** Replace the cooling fan correctly according to instructions in this manual. Incorrect cooling fan mounting direction will prevent sufficient cooling of the converter and could damage internal circuits.

### ■ Performance Life Monitors Maintenance Monitors

The converter calculates the maintenance period for components that may require replacement during the life of the converter. A percentage of the maintenance period is displayed on the digital operator by viewing the appropriate monitor parameter.

When the maintenance period reaches 100%, there is increased risk that the converter may malfunction. Yaskawa recommends checking the maintenance period regularly to ensure maximum performance life.

Refer to [Inspection on page 136](#) for more details.

**Table 6.4 Performance Life Monitors Used for Component Replacement**

Parameter	Component	Contents
U4-03	Cooling Fan Circulation Fan	Displays the accumulated operation time of the fan from 0 to 99999 hours. This value is automatically reset to 0 after it reaches 99999.
U4-04	Control Board Cooling Fan	Displays the accumulated fan operation time as a percentage of the specified maintenance period.
U4-05	DC Bus Capacitors	Displays the accumulated time the capacitors are used as a percentage of the specified maintenance period.
U4-06	Inrush (pre-charge) Relay	Displays the number of times the converter is powered up as a percentage of the performance life of the inrush circuit.

## 6.3 Periodic Maintenance

### ■ Alarm Outputs for Maintenance Monitors

An output can be set up to inform the user when a specific components has neared its expected performance life.

When one of multi-function relay output terminals has been assigned the maintenance monitor function (H2-□□ = 2F), the terminal will close when the cooling fan, DC bus capacitors, or DC bus pre-charge relay reach 90% of the expected performance life. Additionally the digital operator will display an alarm like shown in *Table 6.5* to indicate the specific components that may need maintenance.

**Table 6.5 Maintenance Alarms (H2-01 to H2-03 = 2F)**

Digital Operator Alarm Display		Function	Corrective Action
LF-1	LT-1	The cooling fans, the DC bus capacitors, or the DC bus charge circuit have reached 90% of their designated life time	Replace the cooling fan.
LF-2	LT-2		Contact a Yaskawa representative or the nearest Yaskawa sales office on possible converter replacement.
LF-3	LT-3		Contact a Yaskawa representative or the nearest Yaskawa sales office on possible converter replacement.

### ■ Related Parameters

**NOTICE:** Use parameters o4-03, o4-05, and o4-07 to reset a Maintenance Monitor to zero after replacing a specific component. If these parameters are not reset after the corresponding parts have been replaced, the Maintenance Monitor function will continue to count down the performance life from the value that was reached with the old part.

**Table 6.6 Maintenance Setting Parameters**

No.	Name	Function
o4-03 <1><2>	Cooling Fan Operation Time Setting	Sets the value of the fan operation time monitor U4-03 in units of 10 h.
o4-05 <2>	Capacitor Maintenance Setting	Sets the value of the Maintenance Monitor for the capacitors.
o4-07 <2>	DC Bus Pre-Charge Relay Maintenance Setting	Sets the value of the Maintenance Monitor for the soft charge bypass relay.

<1> Parameter o4-03 is set in increments of 10 hours. For example, setting o4-03 to 30 set the operating time for cooling fan maintenance 300 hours and the Cooling Fan Operation Time monitor (U4-03) will show 300 hours.

<2> The maintenance period depends on the operating environment of the converter.

## 6.4 Cooling Fans

**NOTICE:** Follow cooling fan replacement instructions. The cooling fan cannot operate properly when installed incorrectly and could seriously damage the converter. To ensure maximum useful product life, replace all cooling fans when performing maintenance.

Contact a Yaskawa representative or the nearest Yaskawa sales office to order replacement cooling fans as required.

For converters with multiple cooling fans, replace all the fans when performing maintenance to ensure maximum product performance life.

**WARNING!** Electrical Shock Hazard. Do not connect or disconnect wiring while the power is on. Failure to comply can result in serious personal injury. Before servicing the converter, disconnect all power to the equipment. The internal capacitor remains charged even after the power supply is turned off. After shutting off the power, wait for at least the amount of time specified on the converter before touching any components.

**CAUTION!** Burn Hazard. Do not touch a hot converter heatsink. Failure to comply could result in minor or moderate injury. Shut off the power to the converter when replacing the cooling fan. To prevent burns, wait at least 15 minutes and ensure the heatsink has cooled down.

**NOTICE:** Follow cooling fan replacement instructions. Improper fan replacement could cause damage to equipment. Make sure the fan is facing upwards when installing the replacement fan into the converter. Replace all fans when performing maintenance to help ensure maximum useful product life.

### ◆ Number of Cooling Fans

Three-Phase 200 V Class				Three-Phase 400 V Class				
Model	Cooling Fans	Circulation Fans	Page	Model	Cooling Fans	Circulation Fans	Control Board Cooling Fans	Page
2A0005	2	–	143	4A0005	2	–	–	143
2A0010	2	–		4A0010	2	–	–	
2A0020	2	–		4A0020	2	–	–	
2A0030	2	–	145	4A0030	2	–	–	145
2A0050	2	–	147	4A0040	2	–	–	147
2A0065	2	–		4A0060	2	–	–	
2A0090	2	–		4A0100	2	–	–	
2A0130	3	1		4A0130	3	–	–	
				4A0185	3	1	–	
				4A0270	3	2	2	151
				4A0370	3	2	2	
				4A0630	6	4	4	155

### ◆ Cooling Fan Component Names

**WARNING!** Electrical Shock Hazard. Do not connect or disconnect wiring while the power is on. Failure to comply can result in serious personal injury. Before servicing the converter, disconnect all power to the equipment. The internal capacitor remains charged even after the power supply is turned off. After shutting off the power, wait for at least the amount of time specified on the converter before touching any components.

**CAUTION!** Burn Hazard. Do not touch a hot converter heatsink. Failure to comply could result in minor or moderate injury. Shut off the power to the converter when replacing the cooling fan. To prevent burns, wait at least 15 minutes and ensure the heatsink has cooled down.

## 6.4 Cooling Fans

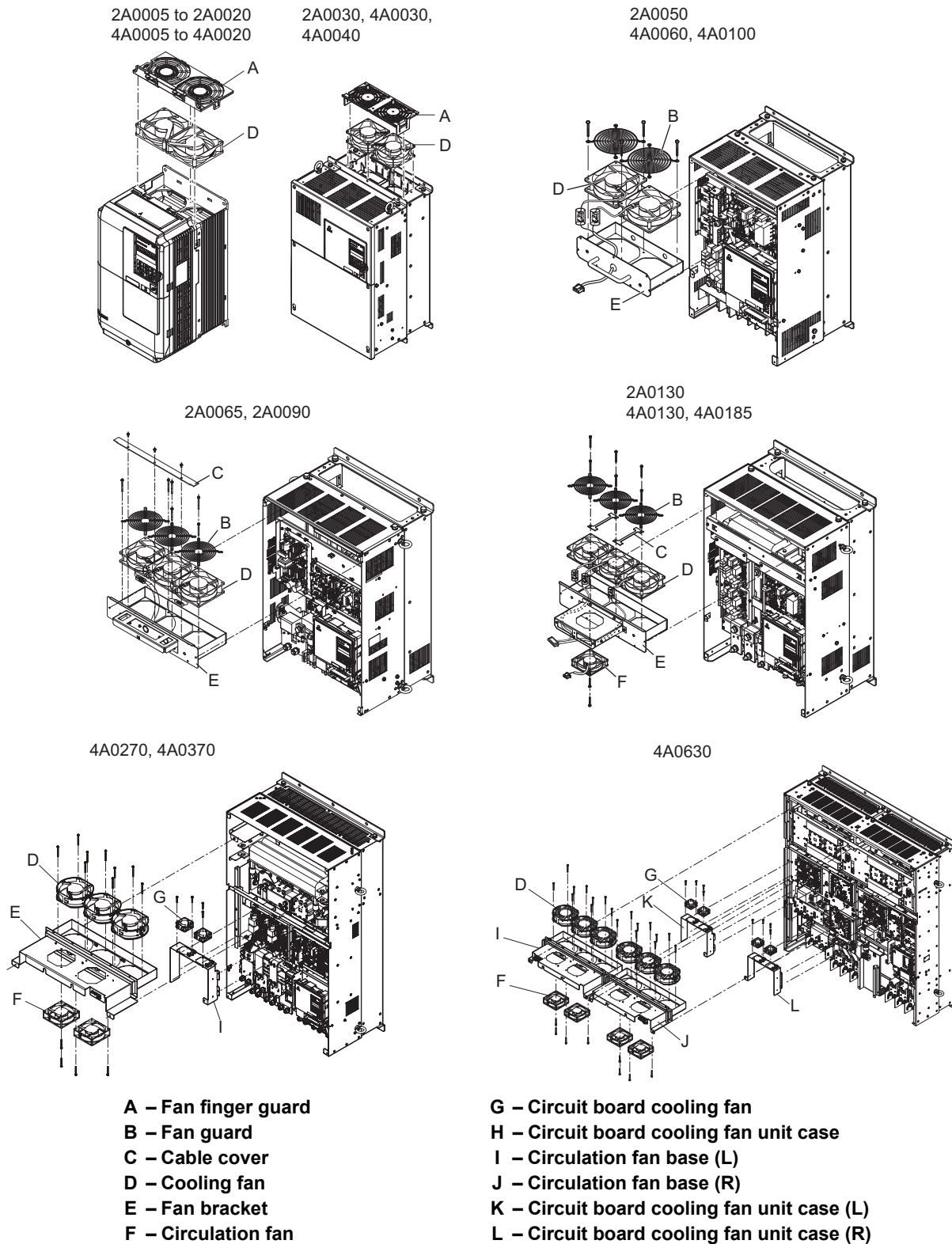

Figure 6.1 Cooling Fan Component Names (2A0030 to 2A0130, 4A0005 to 4A0630)

## ◆ Cooling Fan Replacement

**WARNING!** *Electrical Shock Hazard. Do not connect or disconnect wiring while the power is on. Failure to comply can result in serious personal injury. Before servicing the converter, disconnect all power to the equipment. The internal capacitor remains charged even after the power supply is turned off. After shutting off the power, wait for at least the amount of time specified on the converter before touching any components.*

**CAUTION!** *Burn Hazard. Do not touch a hot converter heatsink. Failure to comply could result in minor or moderate injury. Shut off the power to the converter when replacing the cooling fan. To prevent burns, wait at least 15 minutes and ensure the heatsink has cooled down.*

**NOTICE:** *Follow cooling fan replacement instructions. Improper fan replacement could cause damage to equipment. Make sure the fan is facing upwards when installing the replacement fan into the converter. Replace all fans when performing maintenance to help ensure maximum useful product life.*

### ■ 2A0005 to 2A0020, 4A0005 to 4A0020

#### Removing the Cooling Fan Finger Guard and Cooling Fan

1. Depress the right and left sides of the fan cover tabs and pull upward. Remove the fan cover from the top of the converter. The following figure illustrates a converter with a single cooling fan.

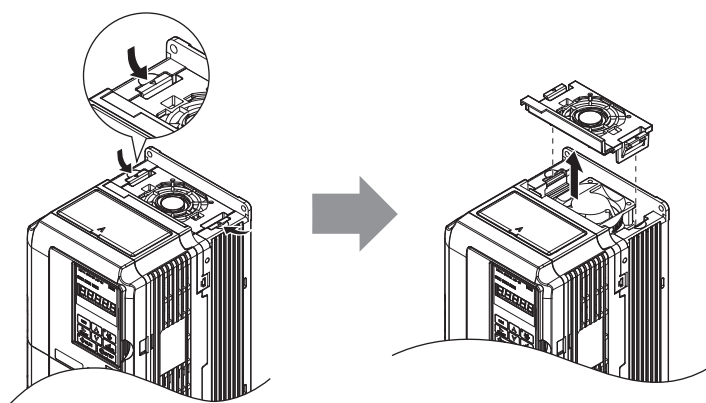

Figure 6.2 Remove the Cooling Fan Finger Guard: 2A0005 to 2A0020, 4A0005 to 4A0020

2. Remove the cooling fan cartridge. Disconnect the pluggable connector and remove the fan.

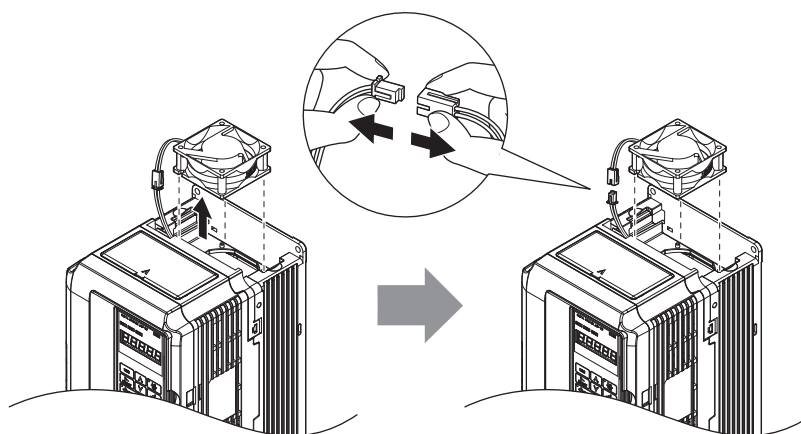

Figure 6.3 Remove the Cooling Fan: 2A0005 to 2A0020, 4A0005 to 4A0020

## 6.4 Cooling Fans

### Installing the Cooling Fan

Reverse the procedure described above to reinstall the cooling fan.

1. Install the replacement cooling fan into the converter, ensuring the alignment pins line up as shown in the figure below.

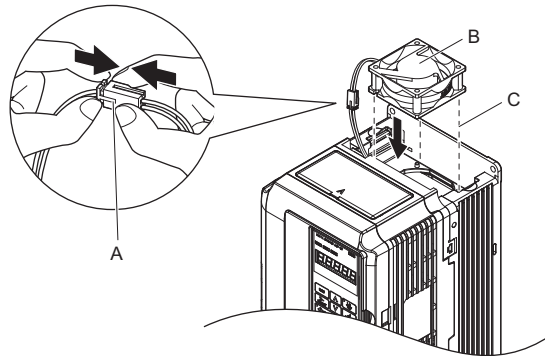

**A – Push the connectors together so no space remains between them**

**C – Make sure the alignment pins line up properly**

**B – Label facing up**

**Figure 6.4 Install the Cooling Fan: 2A0005 to 2A0020, 4A0005 to 4A0020**

2. Properly connect the fan power lines, then place the cable back into the recess of the converter.

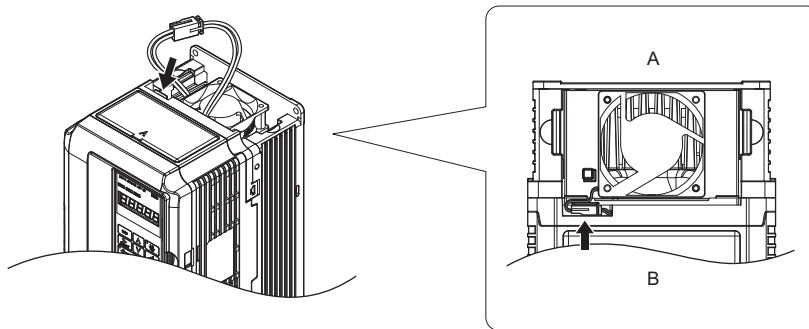

**A – Back**

**B – Front**

**Figure 6.5 Connect the Cooling Fan Power Supply Connectors: 2A0005 to 2A0020, 4A0005 to 4A0020**

3. While pressing in on the hooks on the left and right sides of the fan finger guard, guide the fan finger guard until it clicks back into place.

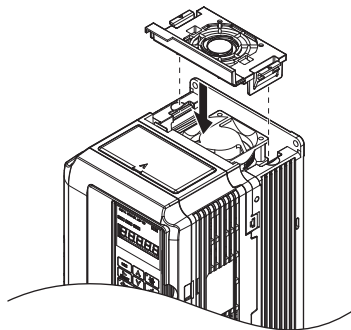

**Figure 6.6 Reattach the Fan Finger Guard: 2A0005 to 2A0020, 4A0005 to 4A0020**

4. Turn on the power supply and set o4-03 to 0 to reset the Maintenance Monitor cooling fan operation time.



## ■ 2A0030, 4A0030, 4A0040

### Removing the Cooling Fan Finger Guard and Cooling Fan

1. While pressing in on the hooks located on the left and right sides of the fan finger guard, free the fan finger guard leading by lifting the back end first.

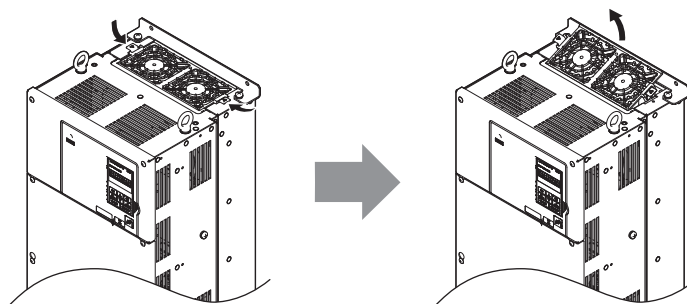

Figure 6.7 Remove the Cooling Fan Finger Guard: 2A0030, 4A0030, 4A0040

2. Lift out the back end of the fan finger guard first. Unplug the replay connector and free the fan finger guard from the converter.

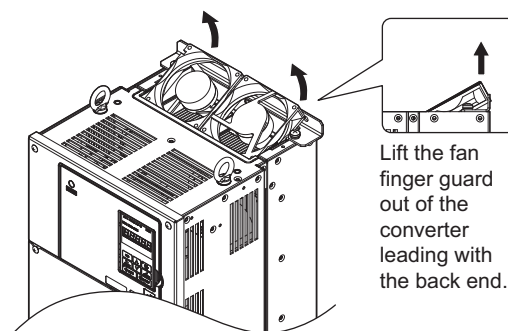
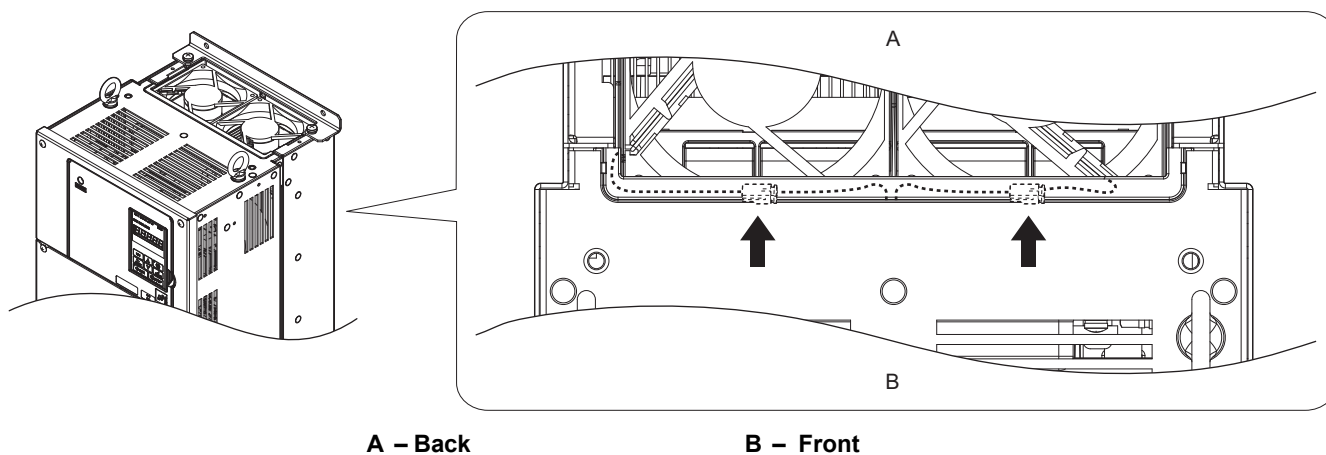

Figure 6.8 Remove the Cooling Fan: 2A0030, 4A0030, 4A0040

### Installing the Cooling Fan

Reverse the procedure described above to reinstall the cooling fan.

1. Properly connect the fan power lines.
2. Place the power supply connectors and cable back into the recess of the converter.



A – Back

B – Front

Figure 6.9 Cooling Fan Power Supply Connectors: 2A0030, 4A0030, 4A0040

## 6.4 Cooling Fans

3. Install the replacement fan into the converter.

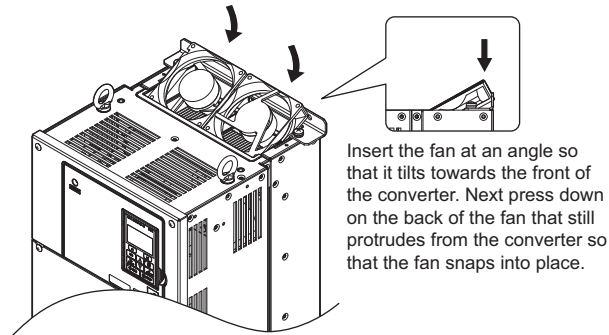

**Figure 6.10 Install the Cooling Fan: 2A0030, 4A0030, 4A0040**

4. Tilt up the back end of the fan finger guard and slide the fan finger guard into the opening near the front of the converter, then guide the fan finger guard into place.

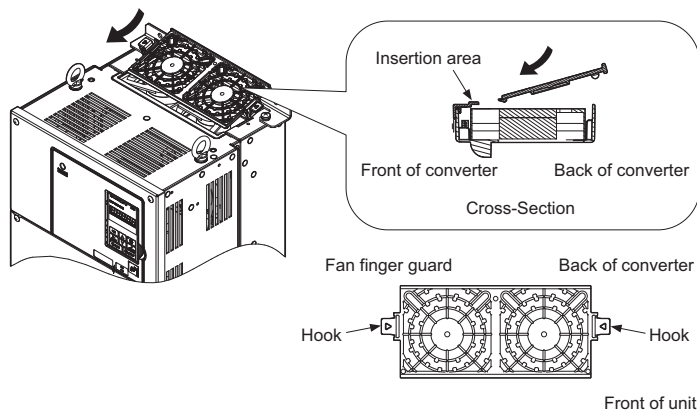

**Figure 6.11 Reattach the Fan Cover: 2A0030, 4A0030, 4A0040**

5. Press in on the hooks of the left and right sides of the fan cover and guide the fan finger guard until it clicks into place.

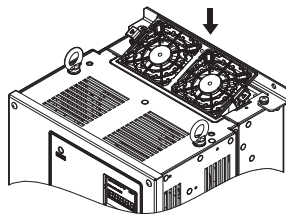

**Figure 6.12 Reattach the Fan Finger Guard: 2A0030, 4A0030, 4A0040**

6. Turn on the power supply and set o4-03 to 0 to reset the Maintenance Monitor cooling fan operation time.

## ■ 2A0050 to 2A0130, 4A0130, 4A0185

### Removing and Disassembling the Cooling Fan Unit

1. Remove the terminal cover and front cover. Refer to [Terminal Cover on page 57](#) for details.
2. Remove the fan connector (CN6). Remove the fan connectors (CN6, CN7) in models 2A0130, 4A0130, and 4A0185.

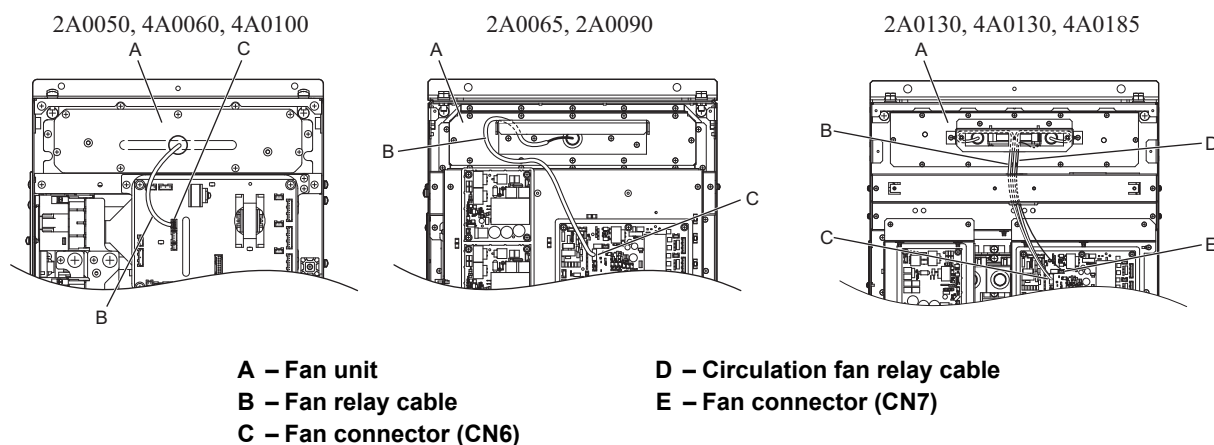

Figure 6.13 Cooling Fan Replacement: Fan Unit and Connectors

3. Remove the screws holding the fan unit in place and slide the fan unit out of the converter.

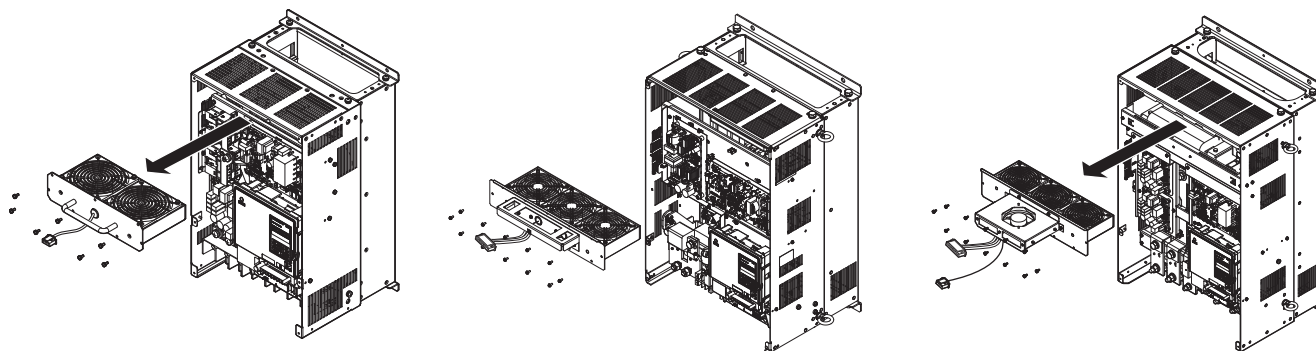

Figure 6.14 Remove the Fan Unit

## 6.4 Cooling Fans

### 4. Remove the fan guard and replace the cooling fans.

- Note:**
1. Do not pinch the fan cable between parts when reassembling the fan unit.
  2. Install the internal circulation fans so that they blow air upward. Install the cooling fan so that it blows air downward.

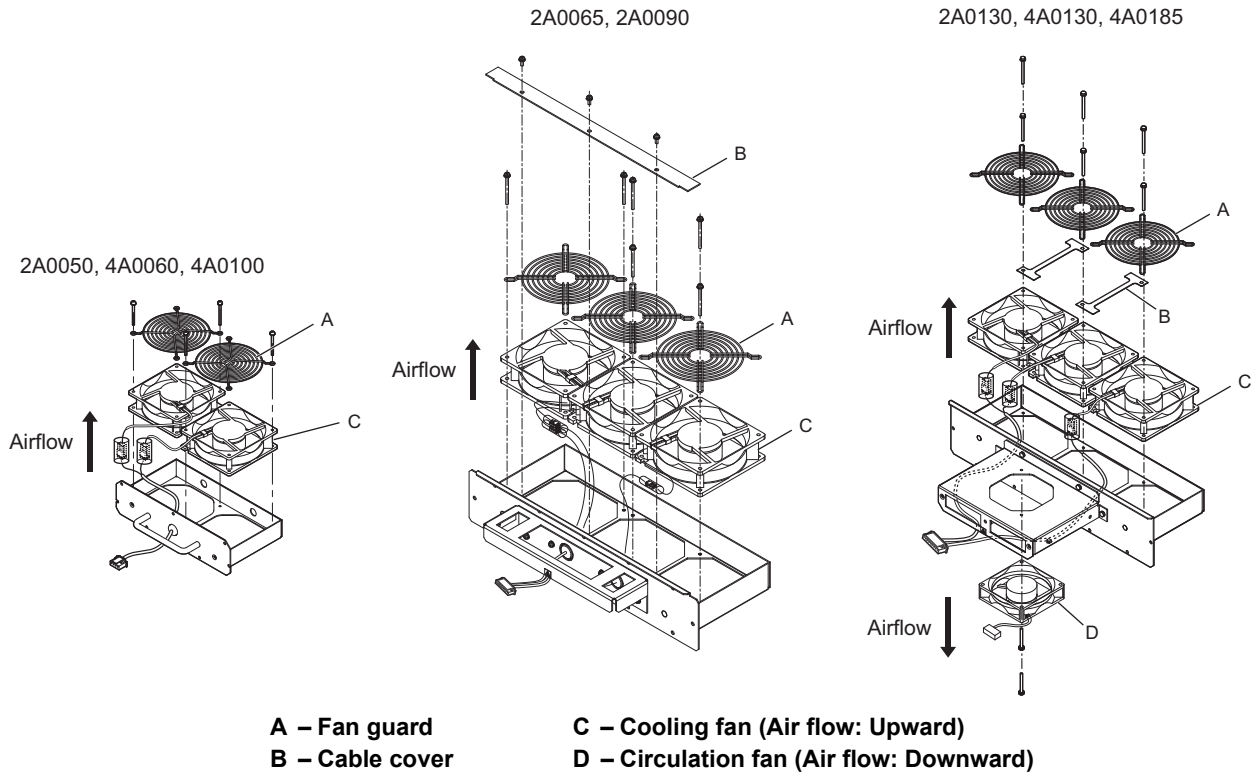
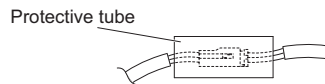

Figure 6.15 Fan Unit Disassembly

### Cooling Fan Wiring: 2A0050, 4A0060, 4A0100

1. Position the protective tube so the fan connector sits in the center of the protective tube.



2. Place the fan connector covered by the tube.

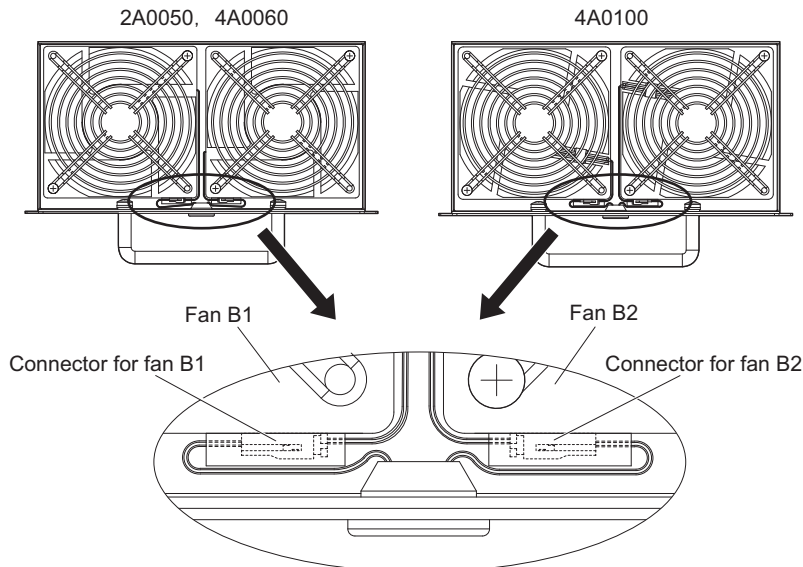
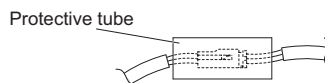

Figure 6.16 Cooling Fan Wiring: 2A0050, 4A0060, 4A0100

3. Make sure that the protective tube does not stick out beyond the fan guard.

**Cooling Fan Wiring: 2A0065 to 2A0090**

1. Position the protective tube so the fan connector sits in the center of the protective tube.

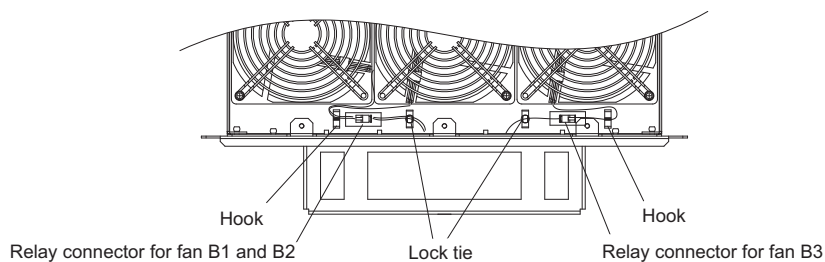

2. Screw down the fan finger guards and the cooling fans to the fan unit base.
3. Place the connectors between the clamping band bases and the hooks.

**Figure 6.17 Cooling Fan Wiring: 2A0065, 2A0090**

4. Double-check the relay connector to ensure it is properly connected.
5. Reattach the cable cover to its original position and tighten the screws so the fan guard holds the cable cover in place.

**Note:** Do not pinch the fan cable between parts when reassembling the fan unit.

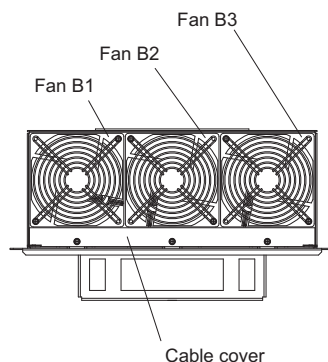
**Figure 6.18 Reattaching the cable cover: 2A0065, 2A0090****Cooling Fan Wiring: 2A0130, 4A0130, 4A0185**

1. Position the protective tube so the fan connector sits in the center of the protective tube.

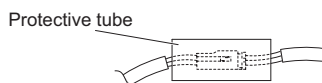

2. In the space between fans 1 and 2, place the fan connector for fan B2 in front of the fan connector for fan B1.

## 6.4 Cooling Fans

3. Place the connector for fan B3 between fans B2 and B3.

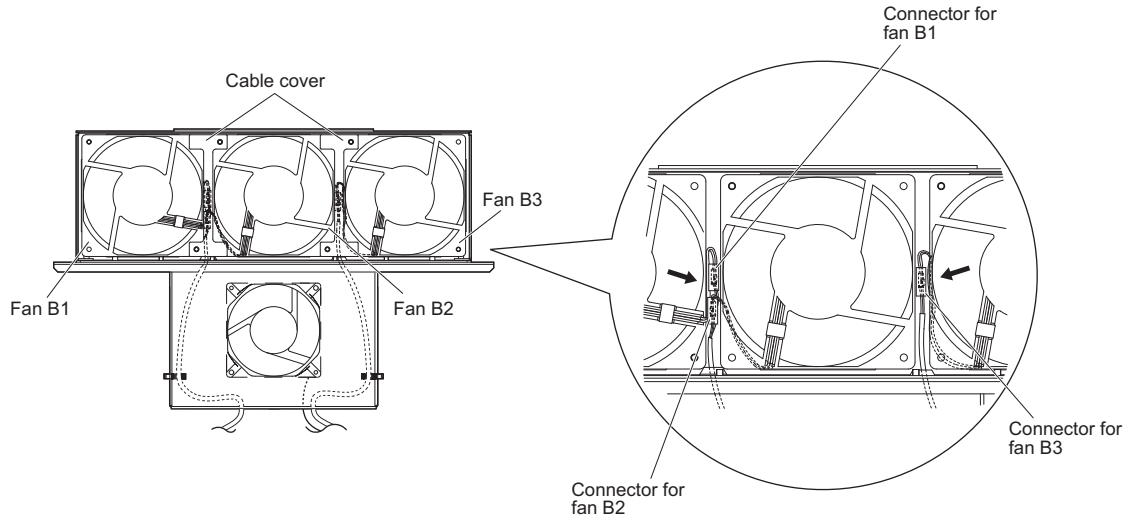

**Figure 6.19 Cooling Fan Wiring: 2A0130, 4A0130, 4A0185**

4. Double-check the relay connector to ensure it is properly connected.
5. Reattach the cable cover to its original position and tighten the screws so the fan guard holds the cable cover in place.

**Note:** Do not pinch the fan cable between parts when reassembling the fan unit.

### Installing the Cooling Fan Unit

1. Reverse the procedure described above to reinstall the cooling fan unit.

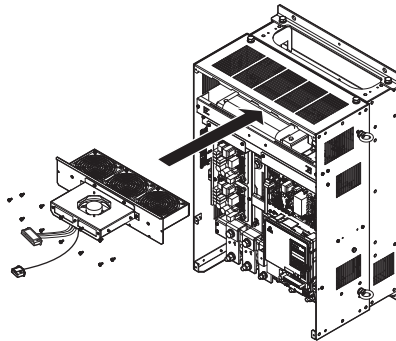

**Figure 6.20 Install the Cooling Fan Unit: 2A0130, 4A0130, 4A0185**

2. Reattach the covers and digital operator.
3. Turn on the power supply and set o4-03 to 0 to reset the Maintenance Monitor cooling fan operation time.

## ■ 4A0270, 4A0370

### Removing and Disassembling the Cooling Fan Unit

1. Remove the terminal cover and front covers 1 and 2. Refer to [Terminal Cover on page 57](#) for details.

**CAUTION!** *Crush Hazard. Do not completely remove the cover screws, just loosen them. If the cover screws are removed completely, the terminal cover may fall off causing an injury. Take special care when removing/reattaching the terminal covers for larger converters.*

2. Remove the connectors for the cooling fan relay and the circuit board cooling fan.

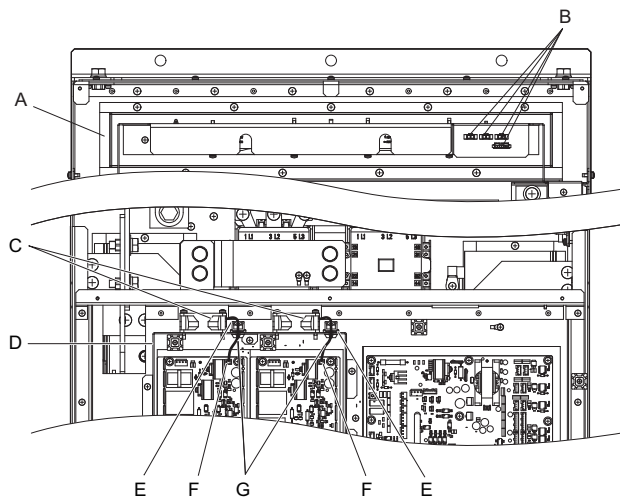

- |   |  |
|---|--|
| <b>A – Fan unit</b>                       | <b>E – Hook</b>                                |
| <b>B – Fan relay connector</b>            | <b>F – Circuit board cooling fan connector</b> |
| <b>C – Circuit board cooling fan</b>      | <b>G – Circuit board cooling fan cable</b>     |
| <b>D – Circuit board cooling fan case</b> |  |

Figure 6.21 Component Names: 4A0270, 4A0370

3. Loosen the screw A (2) and the screw B (9), then slide the panel that the screws held into place to the right.

**Note:** The fan unit can be removed simply by loosening these screws.

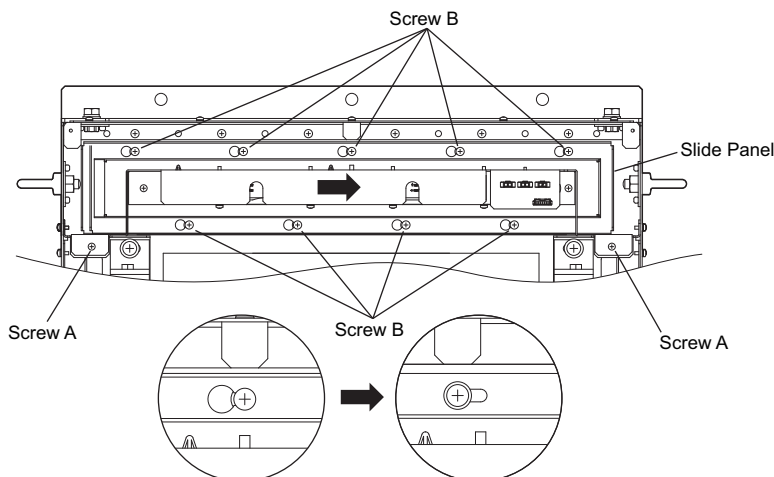
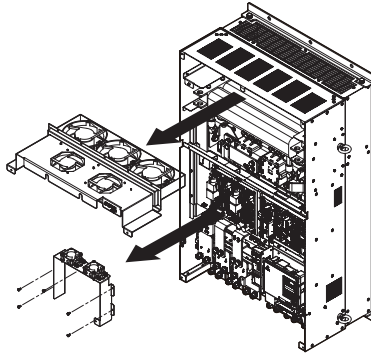

Figure 6.22 Remove the Fan Unit: 4A0270, 4A0370

## 6.4 Cooling Fans

4. Remove the slide panel, fan unit, and circuit board cooling fan unit.

**Note:** The fan unit can be removed simply by loosening these screws.

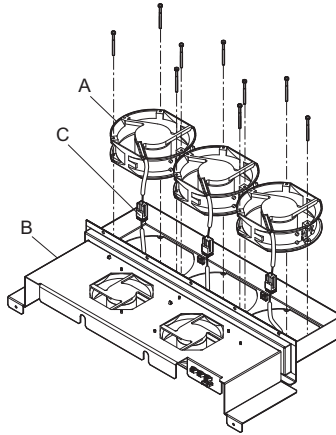

**Figure 6.23 Remove the Fan Unit: 4A0270, 4A0370**

### Replacing the Cooling Fans

1. Replace the cooling fans

**Note:** Do not pinch the fan cable between parts when reassembling the fan unit.



**A – Cooling fan**  
**B – Fan unit case**

**C – Cooling fan Connector**

**Figure 6.24 Fan Unit Disassembly: 4A0270, 4A0370**

2. Place the cooling fan connectors and guide the lead wires so that they are held in place by the cable hooks.

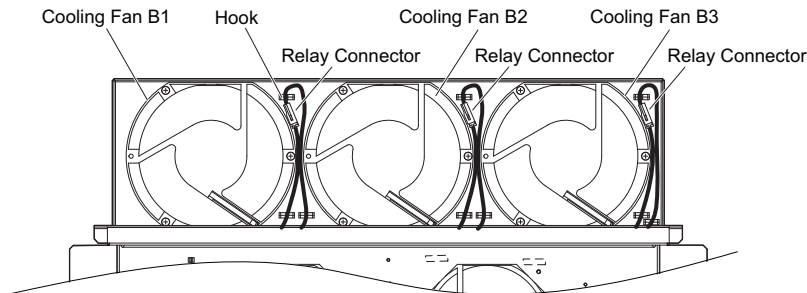

**Figure 6.25 Cooling Fan Wiring: 4A0270, 4A0370**





## 6.4 Cooling Fans

7. Guide the lead wires through the provided hooks so the wires are held in place.

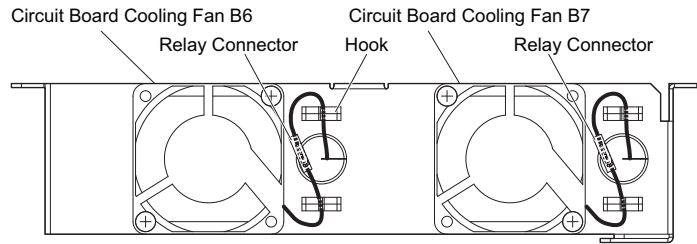
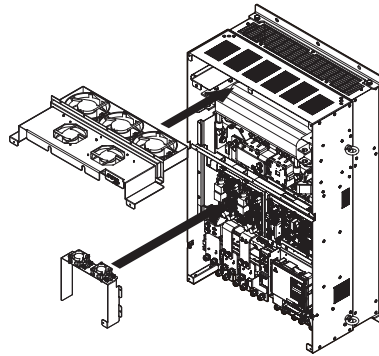

**Figure 6.29 Cooling Fan Wiring: 4A0270, 4A0370**

8. Double-check the relay connector to ensure that it is properly connected.

### Installing the Cooling Fan Unit

1. Reverse the procedure described above to reinstall the cooling fan unit.



**Figure 6.30 Install the Cooling Fan Unit: 4A0270, 4A0370**

2. Reattach the covers and digital operator.
3. Turn on the power supply and set o4-03 to 0 to reset the Maintenance Monitor cooling fan operation time.

■ 4A0630

Removing and Disassembling the Cooling Fan Unit

1. Remove the terminal cover and front covers 1 and 2. Refer to *Removing the Terminal Cover on page 58* for details.

**CAUTION!** *Crush Hazard. Do not completely remove the cover screws, just loosen them. If the cover screws are removed completely, the terminal cover may fall off causing an injury. Take special care when removing/reattaching the terminal covers for larger converters.*

2. Remove the connectors for the cooling fan relay and the circuit board cooling fan.

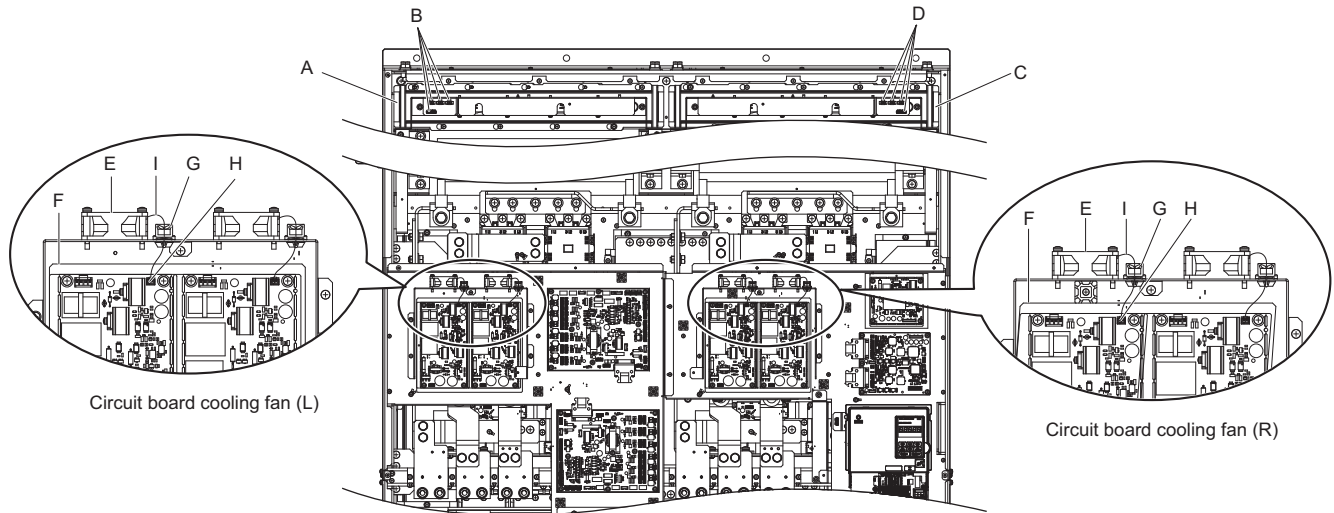

- |                                      |  |
|--------------------------------------|--|
| <b>A – Fan Unit (L)</b>              | <b>F – Circuit Cooling Fan Case</b>            |
| <b>B – Fan Relay Connector (L)</b>   | <b>G – Hook</b>                                |
| <b>C – Fan Unit (R)</b>              | <b>H – Circuit Board Cooling Fan Connector</b> |
| <b>D – Fan Relay Connector (R)</b>   | <b>I – Circuit Board Cooling Fan Cable</b>     |
| <b>E – Circuit Board Cooling Fan</b> |  |

Figure 6.31 Component Names: 4A0630

3. Loosen screw A (4 count) and screw B (18 count), and slide the panel to the right.

**Note:** The fan unit can be removed by loosening these screws; they do not need to be removed.

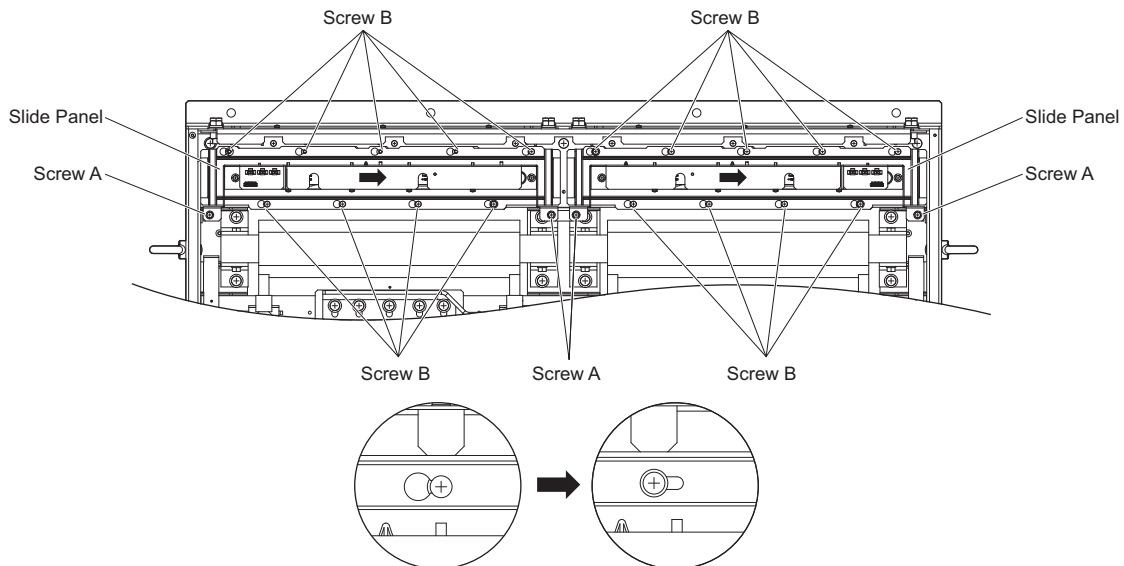
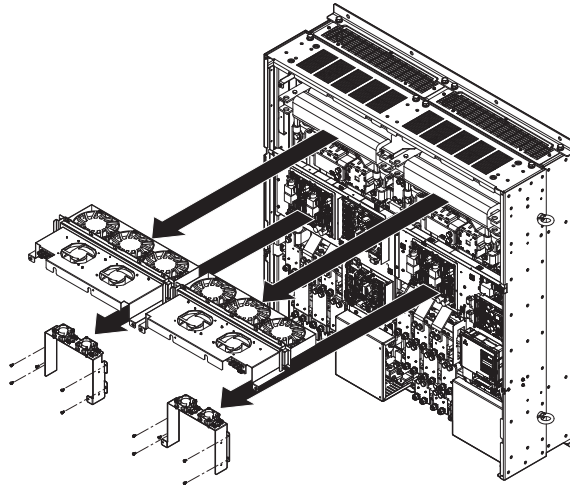

Figure 6.32 Removing the Fan Unit: 4A0630

## 6.4 Cooling Fans

4. Remove the slide panel, fan unit, cooling fan unit, and circuit board cooling fan unit.

**Note:** Remove the slide panel and the cooling fan unit at the same time.



**Figure 6.33 Removing the Fan Units: 4A0630**

### Replacing the Cooling Fans

1. Replace the Cooling Fans.

**Note:** 1. [Figure 6.34](#) shows the right side fan unit.

2. Do not pinch the fan cable between parts when reassembling the fan unit.

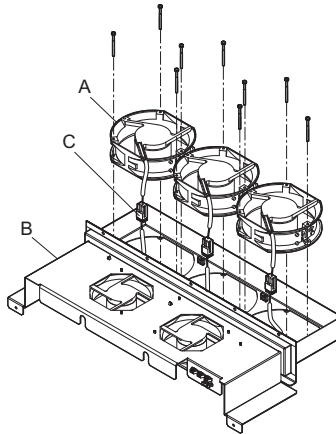

**A – Cooling Fan**  
**B – Fan Unit Case**

**C – Cooling Fan Connector**

**Figure 6.34 Replacing the Cooling Fans: 4A0630**

2. Place the cooling fan connectors and guide the lead wires so that they are held in place by the cable hooks.

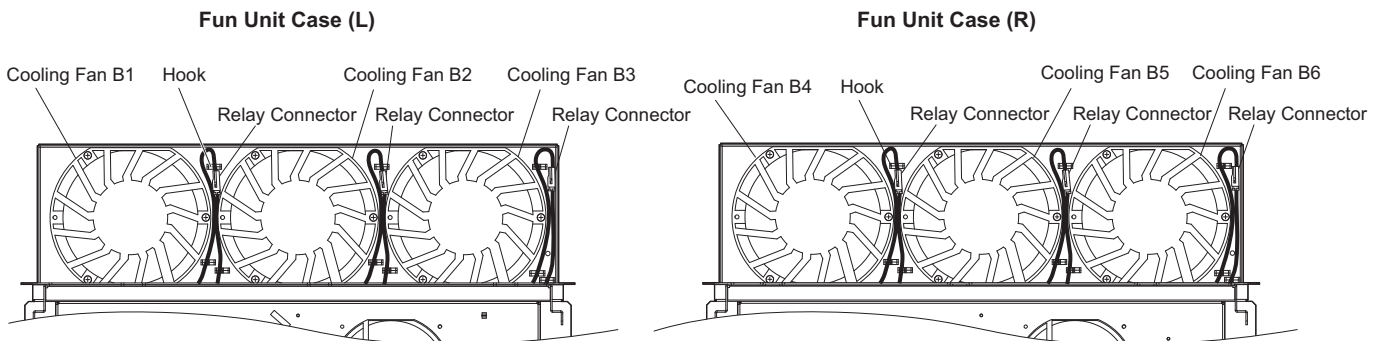

**Figure 6.35 Cooling Fan Wiring: 4A0630**

- Turn the fan unit over and replace the circulation fans.

Note: *Figure 6.36* shows the right side fan unit.

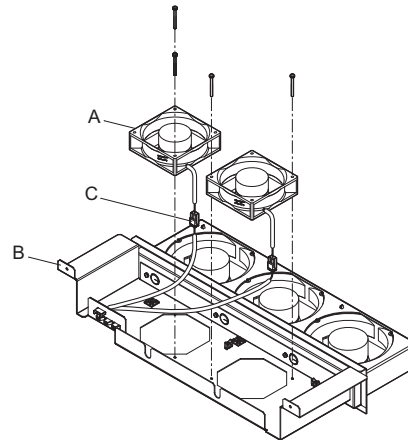

A – Cooling Fan  
B – Fan Unit Case

C – Cooling Fan Connector

**Figure 6.36 Replacing the Circuit Board Cooling Fans**

- Place the cooling fan connectors and guide the lead wires so that they are held in place by the cable hooks.

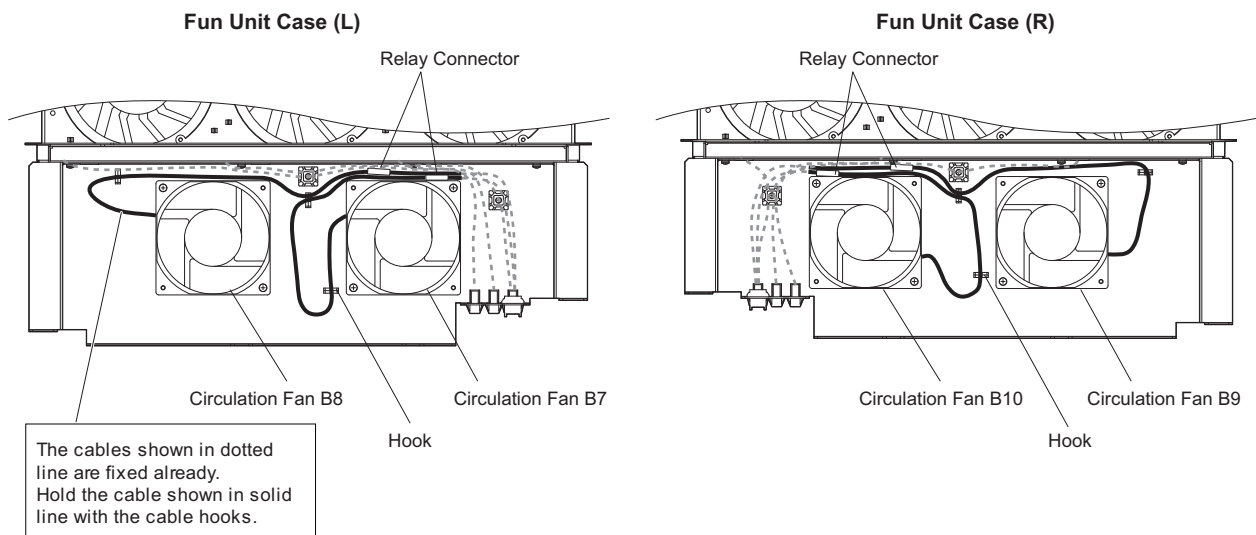
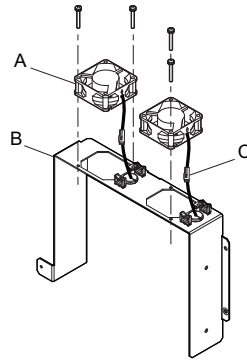

**Figure 6.37 Cooling Fan Wiring: 4A0630**

## 6.4 Cooling Fans

### 5. Replace the circuit board cooling fans.

**Note:** *Figure 6.38* shows the right side circuit board cooling fan.



**A – Circuit Board Cooling Fan**  
**B – Circuit Board Cooling Fan Case**

**C – Protective tube**

**Figure 6.38 Replacing the circuit board cooling fans: 4A0630**

### 6. Position the protective tube so that the fan connector sits in the center of the protective tube. (Only for circuit board cooling fans).

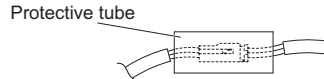

### 7. Guide lead wires through the provided hooks so the wires are held in place.

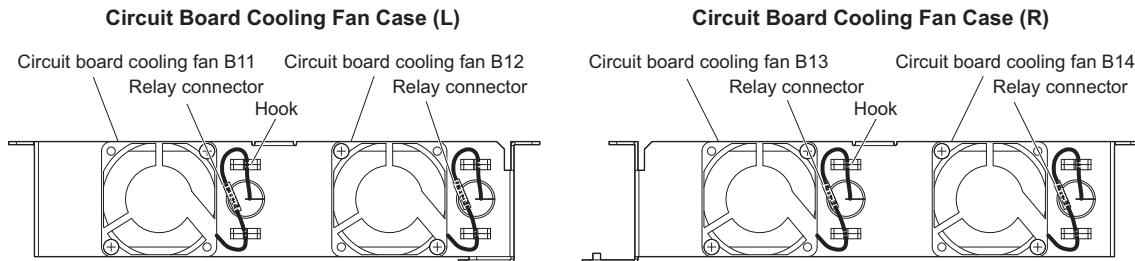

**Figure 6.39 Circuit Board Cooling Fan Wiring: 4A0630**

### 8. Double-check the relay connector to ensure that it is properly connected.

### Installing the Cooling Fan Unit

1. Reverse the procedure described above to reinstall the cooling fan unit.

**Note:** Properly connect the relay connectors to the fan unit connectors.

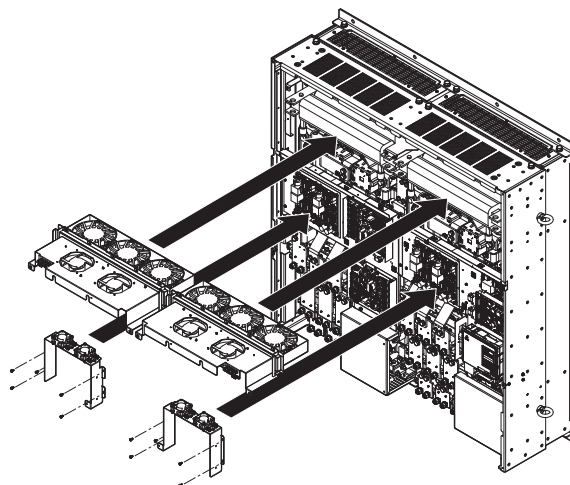

**Figure 6.40** Installing the Cooling Fan Units: 4A0630

2. Reattach the covers and digital operator.
3. Turn the power supply back on and reset the cooling fan operation time for the Maintenance Monitor by setting o4-03 to 0.

# 6.5 Converter Replacement

### ◆ Serviceable Parts

The converter contains some serviceable parts. The following parts can be replaced over the life span of the converter:

- Terminal board I/O PCBs
- Cooling fan (s)
- Front cover

Replace the converter if the main power circuitry is damaged. Contact your local Yaskawa representative before replacing parts if the converter is still under warranty. Yaskawa reserves the right to replace or repair the converter according to Yaskawa warranty policy.

**WARNING! Electrical Shock Hazard.** Do not inspect, connect, or disconnect any wiring while the power is on. Failure to comply can result in serious personal injury. Before servicing the converter, disconnect all power to the equipment. The internal capacitor remains charged even after the power supply is turned off. After shutting off the power, wait for at least the amount of time specified on the converter before touching any components.

### ◆ Terminal Board

The converter has a modular I/O terminal block that facilitates quick converter replacement. The terminal board contains on-board memory that stores all converter parameter settings and allows the parameters to be saved and transferred to the replacement converter. To transfer the terminal board, disconnect the terminal board from the damaged converter and reconnect it to the replacement converter. There is no need to manually reprogram the replacement converter after transferring the terminal board.

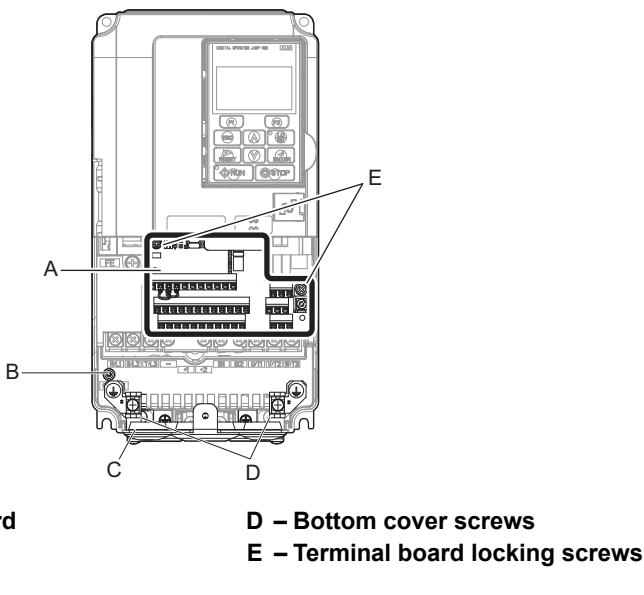

Figure 6.41 Terminal Board



## ◆ Replacing the Converter

**WARNING!** *Electrical Shock Hazard. Do not connect or disconnect wiring while the power is on. Failure to comply can result in serious personal injury. Before servicing the converter, disconnect all power to the equipment. The internal capacitor remains charged even after the power supply is turned off. After shutting off the power, wait for at least the amount of time specified on the converter before touching any components.*

**WARNING!** *Electrical Shock Hazard. Do not allow unqualified personnel to perform work on the converter. Failure to comply could result in serious injury. Installation, maintenance, inspection and servicing must be performed only by authorized personnel familiar with installation, adjustment and maintenance of converters.*

**NOTICE:** *Observe proper electrostatic discharge procedures (ESD) when handling the converter and circuit boards. Failure to comply may result in ESD damage to the converter circuitry.*

The following procedure explains how to replace a converter.

This section provides instructions for converter replacement only.

To install option boards or other types of options, refer to the specific manuals for those options.

### ■ Removing the Converter

1. Remove the terminal cover.

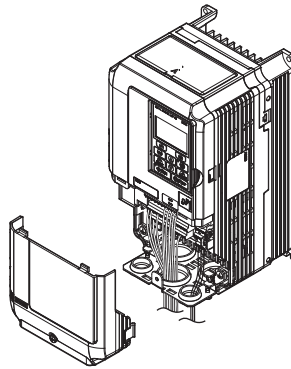

Figure 6.42 Removing the Terminal Cover

2. Loosen the screws holding the terminal board in place. Remove the screw securing the bottom cover and remove the bottom cover from the converter.

**Note:** IP00/Open Type enclosure converters do not have a bottom cover or conduit.

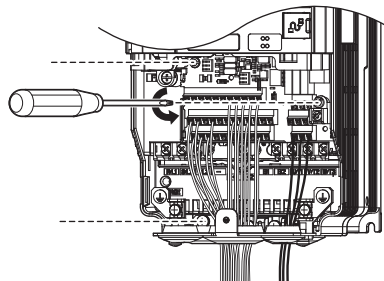

Figure 6.43 Unscrew the Terminal Board and Remove the Terminal Cover

## 6.5 Converter Replacement

- Slide the terminal board as illustrated by the arrows to remove it from the converter along with the bottom cover.

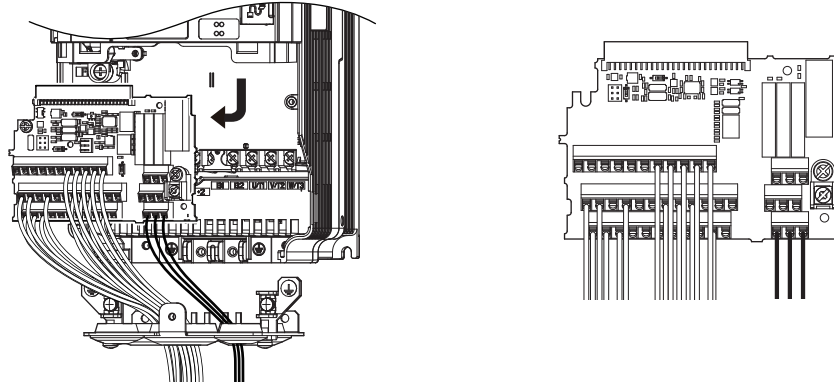

Figure 6.44 Remove the Terminal Board and Disconnected Removable Terminal Board

- Disconnect all option cards and options. Make sure they are intact before reusing them.
- Replace the converter and wire the main circuit.

### ■ Installing the Converter

- After wiring the main circuit, connect the terminal block to the converter as shown in [Figure 6.45](#). Use the installation screw to fasten the terminal block into place.

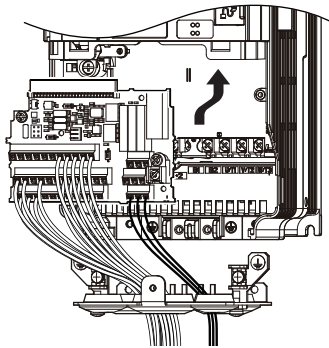

Figure 6.45 Installing the Terminal Board

- Replace the terminal cover.
- Put the terminal cover back into its original place.
- When the power to the converter is first switched on, all parameter settings are transferred from the terminal board into the converter memory. Should an oPE04 error occur, load the parameter settings that have been saved on the terminal board onto the new converter by setting parameter A1-03 to 5550. Reset timers used for the Maintenance Monitor function by setting parameters o4-01 through o4-12 back to 0, and parameter o4-13 to 1.

# Standard Configuration Devices, Peripheral Devices, and Options

---

This chapter explains the installation of peripheral devices and options available for the converter.

<b>7.1</b>	<b>SECTION SAFETY .....</b>	<b>164</b>
<b>7.2</b>	<b>CONVERTER OPTIONS AND PERIPHERAL DEVICES .....</b>	<b>166</b>
<b>7.3</b>	<b>CONNECTING STANDARD CONFIGURATION DEVICES AND PERIPHERAL DEVICES .....</b>	<b>167</b>
<b>7.4</b>	<b>STANDARD CONFIGURATION DEVICES WIRING.....</b>	<b>168</b>
<b>7.5</b>	<b>INSTALLING PERIPHERAL DEVICES.....</b>	<b>171</b>

## 7.1 Section Safety

### WARNING

#### Electrical Shock Hazard

**Do not connect or disconnect wiring while the power is on.**

Failure to comply could result in death or serious injury.

Before servicing, disconnect all power to the equipment. The internal capacitor remains charged even after the power supply is turned off. The charge indicator LED will extinguish when the DC bus voltage is below 50 Vdc. To prevent electric shock, wait for at least the time specified on the warning label; after all indicators are OFF, measure for unsafe voltages to confirm the unit is safe prior to servicing.

**Do not operate equipment with covers removed.**

Failure to comply could result in death or serious injury.

The diagrams in this section may show units without covers or safety shields to show details. Be sure to reinstall covers or shields before operating the unit and run the unit according to the instructions described in this manual.

**Do not remove covers or touch circuit boards while the power is on.**

Failure to comply could result in death or serious injury.

**If a fuse is open or ground fault circuit interrupter GFCI is tripped, check the wiring and the selection of the peripheral devices.**

Contact your supplier if the cause cannot be identified. Failure to comply may result in electrical shock by indirect or direct contact. The converter can cause a residual current with a DC component in the protective earthing conductor.

**Do not allow unqualified personnel to perform work on the unit.**

Failure to comply could result in death or serious injury.

Installation, maintenance, inspection, and servicing must be performed only by authorized personnel familiar with installation, adjustment, and maintenance of this equipment.

**Do not perform work on the unit while wearing loose clothing, jewelry or without eye protection.**

Failure to comply could result in death or serious injury.

Remove all metal objects such as watches and rings, secure loose clothing, and wear eye protection before beginning work on the unit.

**Do not use damaged wires, place excessive stress on wiring, or damage the wire insulation.**

Failure to comply could result in death or serious injury.

#### Fire Hazard

**Tighten all terminal screws to the specified tightening torque.**

Loose electrical connections could result in death or serious injury by fire due to overheating of electrical connections.

### CAUTION

**Carry all standard configuration and peripheral devices in a method suitable for the weight of the device.**

Incorrectly handling devices could cause them to fall and result in injury or damage to the device.

**NOTICE****Observe proper electrostatic discharge procedures (ESD) when handling the unit and circuit boards.**

Failure to comply may result in ESD damage to the unit circuitry.

**Do not use unshielded cable for control wiring.**

Failure to comply may cause electrical interference resulting in poor system performance. Use shielded, twisted-pair wires and ground the shield to the shield ground terminal E (G) of the unit.

**Check all the wiring to ensure that all connections are correct after installing the unit and connecting any other devices.**

Failure to comply could result in damage to the unit.

**Do not operate damaged equipment.**

Failure to comply could result in further damage to the equipment.

Do not connect or operate any equipment with visible damage or missing parts.

# 7.2 Converter Options and Peripheral Devices

**Table 7.1** lists the names of the various peripheral devices, accessories, and options available for Yaskawa converters. Contact Yaskawa or your Yaskawa agent to order these peripheral devices.

- Peripheral Device Selection: Refer to the Yaskawa catalog for selection and part numbers.
- Peripheral Device Installation: Refer to the corresponding option manual for installation instructions.

**Table 7.1 Available Peripheral Devices**

Option	Model Number	Description
<b>Power Options</b>		
24 V Power Supply	PS-A10LB (200 V class) PS-A10HB (400 V class)	Provides power supply for the control circuit and option boards. <b>Note:</b> Parameter settings cannot be changed when the drive is operating solely from this power supply.
<b>Interface Options</b>		
USB Copy Unit (RJ-45/ USB compatible plug)	JVOP-181	<ul style="list-style-type: none"> <li>• Can copy parameter settings easily and quickly to be later transferred to another converter.</li> <li>• Adapter for connecting converter to the USB port of a PC.</li> </ul>
PC Cable	Commercially available USB2.0 A/B cable.	Connect converter and PC when using DriveWizard Industrial. The cable length must be 3 m or less.
LED Operator	JVOP-182	5-digit LED operator; maximum cable length for remote usage: 3 m
LCD Operator Extension Cable	WV001: 1 m WV003: 3 m	Cable for connecting the LCD operator.
<b>Mechanical Options</b>		
Attachment for External Heatsink	–	Attachment for External Heatsink
<b>Communications Option Cards</b>		
MECHATROLINK-II Interface	SI-T3	Used for running or stopping the converter, setting or referencing parameters, and monitoring input current, output voltage, or similar items through MECHATROLINK-II communication with the host controller.
CC-Link Interface	SI-C3 Available soon.	Used for running or stopping the converter, setting or referencing parameters, and monitoring input current, output voltage, or similar items through CC-Link communication with the host controller.
DeviceNet Interface	SI-N3 Available soon.	Used for running or stopping the converter, setting or referencing parameters, and monitoring input current, output voltage, or similar items through DeviceNet communication with the host controller.
PROFIBUS-DP Interface	SI-P3 Available soon.	Used for running or stopping the converter, setting or referencing parameters, and monitoring input current, output voltage, or similar items through PROFIBUS-DP communication with the host controller.
CANopen Interface	SI-S3 Available soon.	Used for running or stopping the converter, setting or referencing parameters, and monitoring input current, output voltage, or similar items through CANopen communication with the host controller.
<b>Monitor Option Cards</b>		
Analog Monitor	AO-A3	Outputs analog signal for monitoring the output state (input frequency, output voltage etc.) of the converter. Output resolution: 11 bit signed (1/2048) Output voltage: 0 to 10 Vdc (non-isolated) Terminals: 2 analog outputs
Digital Output	DO-A3	Outputs isolated type digital signal for monitoring the run state of the converter (alarm signal, during run, etc.) Terminals: 6 photocoupler outputs (48 V, 50 mA or less) 2 relay contact outputs (250 Vac, 1 A or less 30 Vdc, 1 A or less)

## 7.3 Connecting Standard Configuration Devices and Peripheral Devices

**Figure 7.1** illustrates how to configure the converter with standard configuration devices, peripheral devices, and options. Refer to the specific manual for the devices shown below for more detailed installation instructions.

**Note:** Refer to *Standard Connection Diagram on page 48* for details on connecting standard configuration devices.

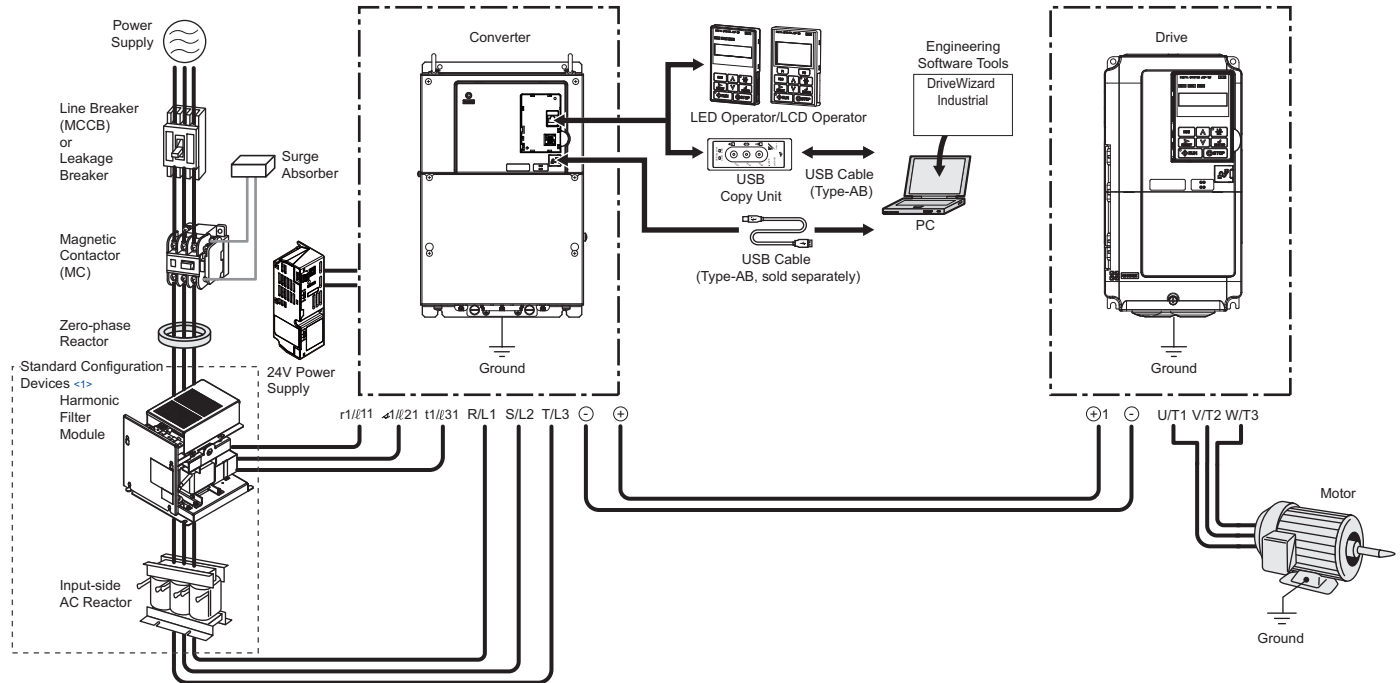

<1> A corresponding input-side AC reactor and harmonic filter module that consider the saturation current and thermal factors are required for each model of converter. Always install the specified devices.

**Figure 7.1 Connecting Standard Configuration Devices and Peripheral Devices  
(Model 2A0030, 2A0130, 4A0030 to 4A0185)**

**Note:** If the converter is set to trigger a fault output when the fault restart function is activated ( $L5-02 = 1$ ), then a sequence to interrupt power when a fault occurs will turn off the power to the converter while the converter attempts to restart. The default setting for L5-02 is 0 (fault output active during restart).

## 7.4 Standard Configuration Devices Wiring

Install the standard configuration devices according to [Table 7.2](#) and [Table 7.3](#) when installing the converter.

For more information, refer to [Standard Connection Diagram on page 48](#). Refer to the product catalog for selection of standard configuration devices.

**Table 7.2 Standard Configuration Devices (200 V Class)**

Voltage Class	200 V Class							
Model	2A0005	2A0010	2A0020	2A0030	2A0050	2A0065	2A0090	2A0130
Harmonic Filter Module	●	●	●	●	●	●	●	●
Input-side AC Reactor 1	●	●	●	●	●	●	●	●
Input-side AC Reactor 2	–	–	–	–	–	–	–	–
Reactor for Harmonic Filter	–	–	–	–	–	–	–	–
Capacitor for Harmonic Filter	–	–	–	–	–	–	–	–

**Table 7.3 Standard Configuration Devices (400 V Class)**

Voltage Class	400 V Class											
Model	4A0005	4A0010	4A0020	4A0030	4A0040	4A0060	4A0100	4A0130	4A0185	4A0270	4A0370	4A0630
Harmonic Filter Module	●	●	●	●	●	●	●	●	●	–	–	–
Input-side AC Reactor 1	●	●	●	●	●	●	●	●	●	●	●	●
Input-side AC Reactor 2	–	–	–	–	–	–	–	–	–	●	●	●
Reactor for Harmonic Filter	–	–	–	–	–	–	–	–	–	●	●	●
Capacitor for Harmonic Filter	–	–	–	–	–	–	–	–	–	●	●	●

### ◆ Wire Gauges and Tightening Torque

Use the tables in this section to select the appropriate wires and crimp terminals.

- Note:**
1. Wire gauge recommendations based on continuous current ratings using 75°C 600 Vac vinyl-sheathed wire assuming ambient temperature within 40°C.
  2. Wire gauge recommendations for models 4A0270 to 4A0630 based on continuous current ratings using 105°C 600 Vac vinyl sheathed wire assuming ambient temperature within 40°C.

Consider the amount of voltage drop when selecting wire gauges. Increase the wire gauge when the voltage drop is greater than 2% of motor rated voltage. Ensure the wire gauge is suitable for the terminal block. Use the following formula to calculate the amount of voltage drop:

$$\text{Line drop voltage (V)} = \sqrt{3} \times \text{wire resistance } (\Omega/\text{km}) \times \text{wire length (m)} \times \text{current (A)} \times 10^{-3}$$

### ■ Harmonic Filter Module

Refer to [Wire Gauges and Tightening Torque on page 69](#) when wiring of the harmonic filter module.



## Input-side AC Reactor 1

Table 7.4 Wire Gauge and Torque Specifications

CIMR-D□	Terminals	For Asia <1>		For U.S.A. <2>		For Europe and China <3>		Screw Size	Tightening Torque N·m (lb·in.)
		Recomm. Gauge mm <sup>2</sup>	Applicable Gauge mm <sup>2</sup>	Recomm. Gauge AWG, kcmil	Applicable Gauge AWG, kcmil	Recomm. Gauge mm <sup>2</sup>	Applicable Gauge mm <sup>2</sup>		
<b>200 V Class</b>									
2A0005	U, V, W	2	2 to 5.5	12	12 to 10	4	4 to 6	M4	1.0 to 1.3 (8.9 to 11.5)
	X, Y, Z								
2A0010	U, V, W	5.5	5.5 to 14	8	8 to 6	4	4 to 16	M5	2.0 to 2.5 (17.7 to 22.1)
	X, Y, Z								
2A0020	U, V, W	14	14 to 22	4	4	16	16 to 25	M6	4.0 to 4.9 (35.4 to 43.4)
	X, Y, Z								
2A0030	U, V, W	38	38	2	2 to 1	25	25 to 35	M8	8.9 to 10.7 (79.7 to 97.4)
	X, Y, Z								
2A0050	U, V, W	60	60	3	3 to 2/0	50	50 to 70	M8	8.9 to 10.7 (79.7 to 97.4)
	X, Y, Z								
2A0065	U, V, W	80 × 2P	80	3/0 × 2P	3/0	95	95	M12	31.4 to 39.2 (283 to 354)
	X, Y, Z								
2A0090	U, V, W	80 × 2P	80 to 100	3/0 × 2P	3/0 to 4/0	95 × 2P	95	M12	32 to 40 (283 to 354)
	X, Y, Z								
2A0130	U, V, W	100 × 2P	100 to 200	300 × 2P	300 to 400	95 × 2P	95 to 240	M12	32 to 40 (283 to 354)
	X, Y, Z								
<b>400 V Class</b>									
4A0005	U, V, W	1.25	1.25 to 5.5	12	12 to 10	4	4 to 6	M4	1.0 to 1.3 (8.9 to 11.5)
	X, Y, Z								
4A0010	U, V, W	2	2 to 5.5	12	12 to 10	4	4 to 6	M4	1.0 to 1.3 (8.9 to 11.5)
	X, Y, Z								
4A0020	U, V, W	8	8	8	8	6	6 to 10	M6	4.0 to 4.9 (35.4 to 43.4)
	X, Y, Z								
4A0030	U, V, W	14	14	6	6	10	10 to 16	M8	8.9 to 10.7 (79.7 to 97.4)
	X, Y, Z								
4A0040	U, V, W	14	14 to 22	4	4	16	16 to 25	M8	8.9 to 10.7 (79.7 to 97.4)
	X, Y, Z								
4A0060	U, V, W	38	38	2	2 to 1	25	25 to 35	M8	8.9 to 10.7 (79.7 to 97.4)
	X, Y, Z								
4A0100	U, V, W	60	60	3 × 2P	3 to 2/0	50	50 to 70	M8	8.9 to 10.7 (79.7 to 97.4)
	X, Y, Z								
4A0130	U, V, W	80 × 2P	80	3/0 × 2P	3/0	95	95	M12	32 to 40 (283 to 354)
	X, Y, Z								
4A0185	U, V, W	80 × 2P	80 to 100	3/0 × 2P	3/0 to 4/0	95 × 2P	95	M12	32 to 40 (283 to 354)
	X, Y, Z								
4A0270	U, V, W	60 × 2P	60 to 150	300 × 2P	300	95 × 2P	95 to 150	M12	32 to 40 (283 to 354)
	X, Y, Z								
4A0370	U, V, W	100 × 2P	100 to 200	4/0 × 4P	4/0 to 300	150 × 2P	150 to 240	M12	32 to 40 (283 to 354)
	X, Y, Z								
4A0630	U, V, W	100 × 4P	100 to 200	4/0 × 8P	4/0 to 300	150 × 4P	150 to 240	M12	32 to 40 (283 to 354)
	X, Y, Z								

<1> Gauges listed here are for use in Japan.

<2> Gauges listed here are for use in the United States.

<3> Gauges listed here are for use in Europe and China.

## 7.4 Standard Configuration Devices Wiring

### ■ Input-side AC Reactor 2

Table 7.5 Wire Gauge and Torque Specifications

Model	Terminals	For Asia <1>		For U.S.A. <2>		For Europe and China <3>		Screw Size	Tightening Torque N·m (lb·in.)
		Recomm. Gauge mm <sup>2</sup>	Applicable Gauge mm <sup>2</sup>	Recomm. Gauge AWG, kcmil	Applicable Gauge AWG, kcmil	Recomm. Gauge mm <sup>2</sup>	Applicable Gauge mm <sup>2</sup>		
4A0270	U, V, W	60 × 2P	60 to 150	300 × 2P	300	95 × 2P	95 to 150	M12	32 to 40 (283 to 354)
	X, Y, Z								
4A0370	U, V, W	100 × 2P	100 to 200	4/0 × 4P	4/0 to 300	150 × 2P	150 to 240	M12	32 to 40 (283 to 354)
	X, Y, Z								
4A0630	U, V, W	100 × 4P	100 to 200	4/0 × 8P	4/0 to 300	150 × 4P	150 to 240	M12	32 to 40 (283 to 354)
	X, Y, Z								

<1> Gauges listed here are for use in Japan.

<2> Gauges listed here are for use in the United States.

<3> Gauges listed here are for use in Europe and China.

### ■ Reactor for Harmonic Filter

Table 7.6 Wire Gauge and Torque Specifications

Model	Terminals	For Asia <1>		For U.S.A. <2>		For Europe and China <3>		Screw Size	Tightening Torque N·m (lb·in.)
		Recomm. Gauge mm <sup>2</sup>	Applicable Gauge mm <sup>2</sup>	Recomm. Gauge AWG, kcmil	Applicable Gauge AWG, kcmil	Recomm. Gauge mm <sup>2</sup>	Applicable Gauge mm <sup>2</sup>		
4A0270	R/L1, S/L2, T/L3	14	14 to 22	4	4	16	16 to 25	M8	8.9 to 10.7 (79.7 to 97.4)
	X, Y, Z								
4A0370	R/L1, S/L2, T/L3	22	22	1	1	25	25	M8	8.9 to 10.7 (79.7 to 97.4)
	X, Y, Z								
4A0630	R/L1, S/L2, T/L3	60	60	1 × 2P	1 to 2/0	70	70	M10	18 to 23 (159 to 204)
	X, Y, Z								

<1> Gauges listed here are for use in Japan.

<2> Gauges listed here are for use in the United States.

<3> Gauges listed here are for use in Europe and China.

### ■ Capacitor for Harmonic Filter

Table 7.7 Wire Gauge and Torque Specifications

Model	Terminals	For Asia <1>		For U.S.A. <2>		For Europe and China <3>		Screw Size	Tightening Torque N·m (lb·in.)
		Recomm. Gauge mm <sup>2</sup>	Applicable Gauge mm <sup>2</sup>	Recomm. Gauge AWG, kcmil	Applicable Gauge AWG, kcmil	Recomm. Gauge mm <sup>2</sup>	Applicable Gauge mm <sup>2</sup>		
4A0270	U, V, W	14	14 to 22	4	4	16	16 to 25	M12	18.0 to 22.0 (159.3 to 194.7)
4A0370	U, V, W	22	22	1	1	25	25	M12	18.0 to 22.0 (159.3 to 194.7)
4A0630	U, V, W	60	60	1 × 2P	1 to 2/0	70	70	M12	18.0 to 22.0 (159.3 to 194.7)

<1> Gauges listed here are for use in Japan.

<2> Gauges listed here are for use in the United States.

<3> Gauges listed here are for use in Europe and China.

## 7.5 Installing Peripheral Devices

This section describes the proper steps and precautions to take when installing or connecting various peripheral devices to the converter.

**NOTICE:** Use a class 2 power supply when connecting to the control terminals. Improper application of peripheral devices could result in converter performance degradation due to improper power supply. Refer to NEC Article 725 Class 1, Class 2, and Class 3 Remote-Control, Signaling, and Power Limited Circuits for requirements concerning class 2 power supplies.

### ◆ Installing a Molded Case Circuit Breaker (MCCB) or Ground Fault Circuit Interrupter (GFCI)

Install an MCCB or GFCI for line protection between the power supply and the main circuit power supply input terminals R/L1, S/L2, and T/L3. This protects the main circuit and devices wired to the main circuit while also providing overload protection.

**NOTICE:** Prevent Equipment Damage. Install a fuse and a GFCI to model 4A0630. Failure to comply may result in damage to the power supply in the event of a short circuit.

Consider the following when selecting and installing an MCCB or a GFCI:

- The capacity of the MCCB or GFCI should be 1.5 to 2 times the rated output current of the converter. Use an MCCB or GFCI to keep the converter from faulting out instead of using overheat protection (150% for one minute at the rated output current).
- If several converters are connected to one MCCB or GFCI that is shared with other equipment, use a sequence that shuts the power OFF when errors are output by using magnetic contactor (MC) as shown in [Figure 7.2](#).

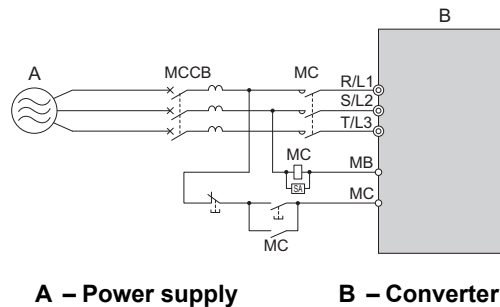

A – Power supply

B – Converter

Figure 7.2 Power Supply Interrupt Wiring (Example)

**WARNING!** Electrical Shock Hazard. Disconnect the MCCB (or GFCI) and MC before wiring terminals. Failure to comply may result in serious injury or death.

## 7.5 Installing Peripheral Devices

---

### ■ Application Precautions when Installing a GFCI

Converter outputs generate high-frequency leakage current as a result of high-speed switching. Install a GFCI on the input side of the converter to switch off potentially harmful leakage current.

Use a GFCI with harmonic countermeasures and with a rated operating current of 30 mA minimum for each connected converter at the power supply side to eliminate harmonic leakage current and suppress any potentially harmful frequencies.

Leakage current can cause unprotected components to operate incorrectly. If this is a problem, lower the carrier frequency, replace the components in question with parts protected against harmonic current, or increase the sensitivity amperage of the circuit interrupter to at least 200 mA per converter.

Factors in determining leakage current:

- Size of the converter
- EMI/RFI filter
- Carrier frequency
- Motor cable type and length

Select an interrupter that senses all types of current (AC and DC) and high frequency currents to safely protect the system.

---

### ◆ Installing a Magnetic Contactor at the Power Supply Side

#### ■ Disconnecting the Power Supply

Instead of an MCCB, you can also use an MC in the sequence to turn off the power supply for the main circuits when protection functions in the converter are activated or for emergency stop operations. However, if an MC at the input (primary side) to the converter is used to force the converter to stop, it will stop without performing regenerative operation. Create the sequence carefully.

**NOTICE:** Do not connect electromagnetic switches or MCs to the output motor circuits without proper sequencing. Improper sequencing of output motor circuits could result in damage to the converter.

**NOTICE:** Install an MC on the input side of the drive when the converter should not automatically restart after power loss. To get the full performance life out of the electrolytic capacitors and circuit relays, refrain from switching the converter power supply off and on more than once every 30 minutes. Frequent use can damage the converter. Use the converter to stop and start the motor.

**NOTICE:** Use a magnetic contactor (MC) to ensure that power to the converter can be completely shut off when necessary. The MC should be wired so that it opens when a fault output terminal is triggered.

**Note:** Set up a delay that prevents the MC from opening prematurely to continue operating the converter through a momentary power loss.

---

### ◆ Connecting a Surge Absorber

A surge absorber suppresses surge voltage generated from switching an inductive load near the converter. Inductive loads include magnetic contactors, relays, valves, solenoids, and brakes. Always use a surge absorber or diode when operating with an inductive load.

**WARNING! Fire Hazard.** Do not connect surge absorbers to the converter output power terminals. Failure to comply may result in serious injury or death by fire or flying debris.

---

### ◆ Attachment for External Heatsink Mounting

An external attachment can be used to project the heatsink outside of an enclosure to ensure that there is sufficient air circulation around the heatsink.

Contact a Yaskawa sales representative or Yaskawa directly for more information on this attachment.

# Appendix: A

## Specifications

---

This chapter provides the specifications of the converter and describes the derating methods.

<b>A.1</b>	<b>POWER RATINGS</b> .....	<b>174</b>
<b>A.2</b>	<b>CONVERTER SPECIFICATIONS</b> .....	<b>175</b>
<b>A.3</b>	<b>HEAT LOSS DATA</b> .....	<b>177</b>
<b>A.4</b>	<b>DERATING DATA</b> .....	<b>178</b>

## A.1 Power Ratings

**Table A.1 Power Ratings (Three-Phase 200 V Class)**

Item		Specification							
Model		2A0005	2A0010	2A0020	2A0030	2A0050	2A0065	2A0090	2A0130
<b>Maximum Applicable Motor Capacity [HP]</b>		5.0	10	20	30	50	75	100	150
<b>Rating</b>	<b>Rated Output Capacity [HP]</b> <1>	6.7	13.4	26.8	40	67	87	120	174
<b>Rating</b>	<b>Rated Output Current (DC) [A]</b>	15	30	61	91	152	197	273	394
	<b>Rated Input Current (AC) [A]</b>	15	29	57	83	140	200	270	400
	<b>Rated Output Voltage [V]</b>	DC330 V							

<1> Rated output capacity is calculated with a rated input voltage of 220 V.

**Table A.2 Power Ratings (Three-Phase 400 V Class)**

Item		Specification											
Model		4A0005	4A0010	4A0020	4A0030	4A0040	4A0060	4A0100	4A0130	4A0185	4A0270	4A0370	4A0630
<b>Maximum Applicable Motor Capacity [HP]</b>		5	10	20	30	40.0	60.0	100.0	150.0	200	300	400	750
<b>Rating</b>	<b>Rated Output Capacity [HP]</b> <1>	6.7	13.4	26.8	40	54.0	80.0	134.0	174.0	250	360	500	850
<b>Rating</b>	<b>Rated Output Current (DC) [A]</b>	8	15	30	45	61	91	152	197	280	409	561	955
	<b>Rated Input Current (AC) [A]</b>	8	16	30	43	58	86	145	210	300	410	560	1040
	<b>Rated Output Voltage [V]</b>	DC660 V											

<1> Rated output capacity is calculated with a rated input voltage of 440 V.

## A.2 Converter Specifications

Item		Specification
Input	Rated Voltage Rated Frequency	200 V Class: 200 to 240 Vac 50/60 Hz 400 V Class: 380 to 480 Vac 50/60 Hz
	Allowable Voltage Fluctuation	-15 to +10%
	Allowable Frequency Fluctuation	±2%
Control Characteristics	Control Method	Sine-wave PWM control
	Input Power Factor	Input power factor of 0.99 minimum (for rated operation)
	Output Voltage Accuracy	±5%
	Overload Protection	Converter stops after 60 s at 150% of rated output current or after 3 s at 200% of rated output current.
	Voltage Reference Range	200 V Class: 300 to 360 Vdc 400 V Class: 600 to 730 Vdc
	Carrier Frequency	Depends on the converter capacity <ul style="list-style-type: none"> <li>• 6 kHz 2A0005 to 2A0030, 4A0005 to 4A0060</li> <li>• 4 kHz 2A0050 to 2A0130, 4A0100 to 4A0185</li> <li>• 2 kHz 4A0270 to 4A0630</li> </ul>
Main Control Functions	Torque Limit, Cooling fan on/off switch, Removable Terminal Block with Parameter Backup Function, MEMOBUS/Modbus Communication (RS-422/RS-485 max, 115.2 kbps)	
Protection Functions	Momentary Overcurrent Protection	Operation stops when input current exceeds 200%.
	Open Fuse	Operation stops if the fuse opens.
	Overload	Operation stops after 60 s at 150% of rated output current. Operation stops after 3 s at 200% of rated output current. (power supply and regeneration)
	Overvoltage Protection (Output)	200 V class: Stops when DC bus voltage exceeds approximately 410 Vdc 400 V class: Stops when DC bus voltage exceeds approximately 820 Vdc
	Overvoltage Protection (Input)	200 V class: Stops when input voltage exceeds approximately 227 Vac 400 V class: Stops when input voltage exceeds approximately 554 Vac
	Undervoltage Protection (Output)	200 V class: Stops when DC bus voltage is approximately 190 Vdc 400 V class: Stops when DC bus voltage is approximately 380 Vdc
	Undervoltage Protection (Input)	200 V class: Stops when input voltage is approximately 150 Vac 400 V class: Stops when input voltage is approximately 300 Vac
	Momentary Power Loss Ride-Thru	Immediate stop after Momentary Power Loss is detected.
	Power Supply Frequency Fault	Operation stops if the input frequency deviates by ±6 Hz of rated frequency.
	Heatsink Overheat Protection	Thermistor protection
	Ground Protection	Electronic circuit protection <-I>
DC Bus Charge LED	Remains lit until DC bus voltage is 50 V	
Environment	Area of Use	Indoors
	Ambient Temperature	IP00/Open Type enclosure: -10°C to +50°C (14°F to 122°F) IP20/Open Type enclosure: -10°C to +40°C (14°F to 104°F)
	Humidity	95 RH% or less (no condensation)
	Vibration/Shock	10 to 20 Hz at 9.8 m/s <sup>2</sup> , 20 to 55 Hz at 5.9 m/s <sup>2</sup> (2A0005 to 2A0050, 4A0005 to 4A0100) 10 to 20 Hz at 9.8 m/s <sup>2</sup> 20 to 55 Hz at 2.0 m/s <sup>2</sup> (2A0065 to 2A0130, 4A0130 to 4A0370) 10 to 20 Hz at 5.9 m/s <sup>2</sup> , 20 to 55 Hz at 2.0 m/s <sup>2</sup> (4A0630)
	Storage Temperature	-20°C to +60°C (-4°F to +140°F)
	Altitude	1000 m (3281 ft) or lower, up to 3000 m (9843 ft) with derating.
Protection Design		IP00/Open Type enclosure, IP20/Open Type enclosure

## A.2 Converter Specifications

---

Item	Specification
<b>Safety Standard</b>	UL508C, IEC/EN 61800-5-1, IEC/EN 61800-3, CAN/CSA-C22.2 No. 14-10, CSA B44.1-04/ASME A17.5-2004

<1> Ground protection cannot be provided when the impedance of the ground fault path is too low, or when the converter is powered up while a ground fault is present at the output.



## A.3 Heat Loss Data

Table A.3 Heat Loss

Model	Rated Amps (A)	Heatsink Loss (W)	Interior Unit Loss (W)	Total Loss (W)
<b>200 V Class</b>				
2A0005	15	93	38	131
2A0010	30	167	57	224
2A0020	61	319	101	420
2A0030	91	380	134	514
2A0050	152	666	245	911
2A0065	197	1193	464	1657
2A0090	273	1616	619	2235
2A0130	394	1918	776	2694
<b>400 V Class</b>				
4A0005	8	83	37	120
4A0010	15	158	58	216
4A0020	30	314	103	417
4A0030	45	263	109	372
4A0040	61	647	201	848
4A0060	91	1092	334	1426
4A0100	152	1303	467	1770
4A0130	197	1969	695	2664
4A0185	280	2864	997	3861
4A0270	409	2477	1323	3799
4A0370	561	3705	1852	5557
4A0630	955	6103	3098	9201

## A.4 Derating Data

The converter can be operated at above the rated temperature, altitude, and default carrier frequency by derating the converter capacity.

### ◆ Temperature Derating

To ensure the maximum performance life, the converter output current must be derated as shown in *Figure A.1* when the converter is installed in areas with high ambient temperature or if converters are mounted side-by-side in a cabinet. In order to ensure reliable converter overload protection, set parameters L8-35 according to the installation conditions.

#### ■ Parameter Settings

If the ambient temperature is higher than the rating or if converters are installed side by side in the control panel, you must set the L8-12 and L8-35 parameters according to the installation conditions. Derate the output current according to *Figure A.1*

No.	Name	Description	Setting Value	Default Setting
L8-12	Ambient Temperature Setting	Adjust the converter overload (oL2) protection level when the converter is installed in an environment that exceeds its ambient temperature rating.	-10 to +50	+40°C
L8-35	Installation Method Selection	0: IP00/IP20/Open Type Enclosure 1: Side-by-Side Mounting 3: External Heatsink Installation	0, 1, 3	Default setting is determined by o2-04 (Drive Model Selection).

#### Setting 0: IP00/IP20/Open Type Enclosure

Converter operation between -10°C and +50°C allows 100% continuous current without derating.

#### Setting 1: Side-by-Side Mounting

Converter operation between -10°C and +30°C allows 100% continuous current without derating. Operation between +30°C and +50°C requires output current derating.

#### Setting 3: External Heatsink Installation

Converter operation between -10°C and +40°C allows 100% continuous current without derating. Operation between +40°C and +50°C requires output current derating.

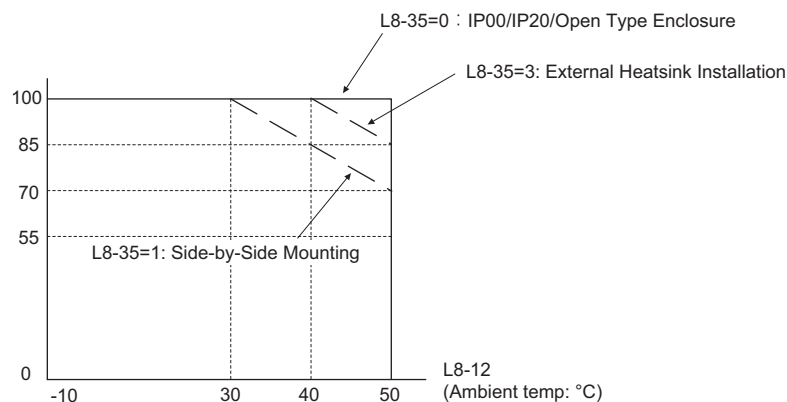

Figure A.1 Ambient Temperature and Installation Method Derating

### ◆ Altitude Derating

Standard ratings are valid for installation altitudes up to 1000 m. For installations from 1000 m to 3000 m, the converter rated voltage and the rated output current must be derated for 1% per 100 m.

# Appendix: B

## Parameter List

---

This appendix contains a full listing of all parameters and settings available in the converter.

<b>B.1</b>	<b>PARAMETER GROUPS .....</b>	<b>180</b>
<b>B.2</b>	<b>PARAMETER TABLES .....</b>	<b>181</b>
<b>B.3</b>	<b>DEFAULTS BY CONVERTER MODEL.....</b>	<b>202</b>

## B.1 Parameter Groups

Parameter Group	Name	Page
<b>A1</b>	Initialization Parameters	<i>181</i>
<b>A2</b>	User Parameters	<i>181</i>
<b>b1</b>	Operation Mode Selection	<i>182</i>
<b>b4</b>	Timer Function	<i>182</i>
<b>C1</b>	Acceleration and Deceleration Times	<i>183</i>
<b>C6</b>	Carrier Frequency	<i>183</i>
<b>C7</b>	DC Bus Voltage Control	<i>183</i>
<b>d8</b>	DC Bus Voltage Reference	<i>184</i>
<b>F4</b>	Analog Monitor Card (AO-A3)	<i>184</i>
<b>F5</b>	Digital Monitor Card (DO-A3)	<i>185</i>
<b>F6</b>	Communication Option Card	<i>185</i>
<b>H1</b>	Multi-Function Digital Inputs	<i>186</i>
<b>H2</b>	Multi-Function Relay Outputs	<i>187</i>
<b>H3</b>	Multi-Function Analog Inputs	<i>188</i>



Parameter Group	Name	Page
<b>H4</b>	Multi-Function Analog Outputs	<i>190</i>
<b>L2</b>	Momentary Power Loss Ride-Thru	<i>190</i>
<b>L5</b>	Fault Restart	<i>191</i>
<b>L7</b>	Motoring Limit	<i>191</i>
<b>L8</b>	Drive Protection	<i>192</i>
<b>o1</b>	Digital Operator Display Selection	<i>193</i>
<b>o2</b>	Digital Operator Keypad Functions	<i>193</i>
<b>o3</b>	Copy Function	<i>194</i>
<b>o4</b>	Maintenance Monitor Settings	<i>194</i>
<b>U1</b>	Operation Status Monitors	<i>195</i>
<b>U2</b>	Fault Trace	<i>197</i>
<b>U3</b>	Fault History	<i>199</i>
<b>U4</b>	Maintenance Monitors	<i>199</i>

## B.2 Parameter Tables

### ◆ A: Initialization Parameters

The A parameter group creates the operating environment for the converter. This includes the parameter Access Level, Control Method, Password, User Parameters and more.

 : Indicates that the parameter setting can be changed while the converter is operating.

No. (Address Hex)	Name	LCD Display	Description	Values
<b>A1: Initialization</b>				
A1-00 (100H)  <I>	Language Selection	Select Language 0: English 1: ニホンゴ (Japanese) 7: Chinese	0: English 1: Japanese 7: Chinese	Default: 0 Min.: 0 Max.: 7
A1-01 (101H) 	Access Level Selection	Access Level 0: Operation Only 1: User Parameters 2: Advanced Level	0: View and set A1-01 and A1-04. U□-□□ parameters can also be viewed. 1: User Parameters (access to a set of parameters selected by the user, A2-01 to A2-32) 2: Advanced Access (access to view and set all parameters)	Default: 2 Min.: 0 Max.: 9999
A1-03 (103H)	Initialize Parameters	Init Parameters 0: No Initialize 1110: User Initialize 2220: 2-Wire Initial 3330: 3-Wire Initial 5550: oPE04 error reset	0: No initialization 1110: User Initialize (parameter values must be stored using parameter o2-03) 2220: 2-Wire initialization 3330: 3-Wire initialization 5550: oPE04 error reset	Default: 0 Min.: 0 Max.: 5550
A1-04 (104H)	Password	Enter Password	When the value set into A1-04 does not match the value set into A1-05, parameters A1-01 through A1-03, A1-06, and A2-01 through A2-33 cannot be changed.	Default: 0000 Min.: 0000 Max.: 9999
A1-05 (105H)	Password Setting	Select Password		
<b>A2: User Parameters</b>				
A2-01 (106H)	User Parameters 1	User Param 1	Recently edited parameters are listed here. The user can also select parameters to appear here for quicker access.	Default: b1-18 Range: A1-00 to o4-19
A2-02 (107H)	User Parameters 2	User Param 2		Default: b1-02 Range: A1-00 to o4-19
A2-03 (108H)	User Parameters 3	User Param 3		Default: b8-01 Range: A1-00 to o4-19
A2-04 to A2-32 (109H to 125H)	User Parameters 4 to 32	User Param 4 - 32		Default: – Range: A1-00 to o4-19
A2-33 (126H)	User Parameter Automatic Selection	User Parms Sel 0: Disabled 1: Enabled		Determines whether recently edited parameters are saved to the second half of the User Parameters (A2-17 to A2-32) for quicker access. 0: Parameters A2-01 to A2-32 are reserved for the user to create a list of User Parameters. 1: Save history of recently viewed parameters. Recently edited parameters will be saved to A2-17 through A2-32 for quicker access.

<I> Parameter setting value is not reset to the default value when the converter is initialized.

## B.2 Parameter Tables





### ◆ b: Application

Application parameters configure the source of the operation mode selection.

No. (Address Hex)	Name	LCD Display	Description	Values
<b>b1: Operation Mode Selection</b>				
b1-02 (181H)	Run Command Selection 1	Run Source 1 0: Digital operator 1: Digital Inputs 2: Communication 3: Option PCB	0: Digital operator 1: Digital input terminals 2: MEMOBUS/Modbus communications 3: Option PCB	Default: 1 Range: 0 to 3
b1-06 (185H)	Digital Input Reading	Cntl Input Scans 1: Scan 2: Scans	Defines how the digital inputs are read. The inputs are acted upon every 1 ms or 2 ms depending upon the setting. 0: Input status is read once and processed immediately (for quicker response) 1: Input is read twice and processed only if the status is the same in both readings (robust against noisy signals)	Default: 1 Range: 0, 1
b1-08 (187H)	Run Command Selection in Programming Mode	RUN dur PRG Mode 0: Run Disabled@PRG 1: ModeRun Enabled@PRG 2: Prg only @ Stop	Allow the converter to run while in Programming Mode. 0: Run command is not accepted while in Programming Mode. 1: Run command is accepted while in Programming Mode. 2: Prohibit entering Programming Mode during run.	Default: 0 Range: 0 to 2
b1-17 (1C6H)	Run Command at Power Up	Run Cmd @ Pwr On 0: Cycle Ext Run 1: Accept Ext Run	Determines whether an external Run command that is active during power up will start the converter. 0: Disregarded. A new Run Command must be issued. 1: Allowed. Converter will start immediately if Run Command is present at power up.	Default: 0 Range: 0, 1
b1-18 (179H)	Voltage Reference Source	Reference Sel 0: Operator 1: Analog Input 2: Serial Com 3: Option PCB 7: AutoMode1 8: AutoMode2	Sets the input source for the voltage reference. 0: Digital operator 1: Control circuit terminal (analog input) 2: MEMOBUS/Modbus communications 3: Option card 7: Input voltage based control 1 8: Input voltage based control 2	Default: 0 Range: 0 to 8
<b>b4: Timer Function</b>				
b4-01 (1A3H)	Timer Function On-Delay Time	Delay-ON Timer	Sets the on-delay times for a digital timer output (H2-□□ = 12). The output is triggered by a digital input programmed to H1-□□ = 18.	Default: 0.0 s Min.: 0.0 s Max.: 3000.0 s
b4-02 (1A4H)	Timer Function Off-Delay Time	Delay-OFF Timer	Sets the off-delay times for a digital timer output (H2-□□ = 12). The output is triggered by a digital input programmed to H1-□□ = 18.	Default: 0.0 s Min.: 0.0 s Max.: 3000.0 s

## ◆ C: Tuning

Tuning parameters set the voltage increase time, voltage decrease time, carrier frequency, and DC bus voltage control.

No. (Address Hex)	Name	LCD Display	Description	Values
<b>C1: Voltage Increase and Decrease Times</b>				
C1-20 (265H) 	Voltage Increase Time	Vref Inc Ramp t	Sets the output voltage increase time in seconds. Set the time to increase from 0% to 100%. 400 V Class: 800 V/C1-20 (V/s) 200 V Class: 400 V/C1-20 (V/s)	Default: 10.0 s Min.: 0.0 s Max.: 100.0 s
C1-21 (266H) 	Voltage Decrease Time	Vref Dec Ramp t	Sets the output voltage decrease time in seconds. Set the time to decrease from 100% to 0%. 400 V Class: 800 V/C1-21 (V/s) 200 V Class: 400 V/C1-21 (V/s)	Default: 10.0 s Min.: 0.0 s Max.: 100.0 s
<b>C6: Carrier Frequency</b>				
C6-03 (225H)	Carrier Frequency Upper Limit	CarrierFreq Max	C6-03 is displayed on the operator, but cannot be set.	–
<b>C7: DC Bus Voltage Control</b>				
C7-01 (253H) 	DC Bus Voltage Control (Avr) Proportional Gain	AVR P Gain	Sets the proportional gain for DC bus voltage control (Avr).	Default: 20.00 Min.: 1.00 Max.: 300.00
C7-02 (254H) 	DC Bus Voltage Control (Avr) Integral Time	AVR I Time	Sets the integral time for DC bus voltage control (Avr).	Default: 0.500 s Min.: 0.000 s Max.: 10.000 s
C7-03 (255H)	DC Bus Voltage Control (Avr) Primary Delay Time Constant	AVR Delay Time	Sets the primary delay time constant for DC bus voltage control (Avr).	Default: 0.000 s Min.: 0.000 s Max.: 0.500 s
C7-12 (26EH)	Reactive Current Reference Bias Automatic Calculation Selection	React I Bias Sel	There is normally no need to change this parameter from the default value. Sets whether to automatically calculate the leading current compensation for the control process to compensate the leading current in the reactive current reference so that the leading current becomes 0. 0: Disabled 1: Enable (Automatically calculate the reactive current reference bias.)	Default: 1 Range: 0, 1
C7-41 (1128H)	Gain for Active Damping 2	Damp Gain 2	There is normally no need to change this parameter from the default value.	Default: 0.000 Min.: 0.000 Max.: 10.000
C7-42 (1129H)	Gain for Automatic Compensation of Leading Current	Id Bias Gain	There is normally no need to change this parameter from the default value. It is used to make fine adjustments to the power factor.	Default: 100.0% Min.: 0.0% Max.: 1000.0%
C7-43 (112AH)	Input Voltage Offset Adjustment	Vac Bias Adj Sel	There is normally no need to change this parameter from the default value. This parameter is for factory setting. If the setting is not correct, the converter may be damaged. 0: Standard 1: Start offset adjustment. (The parameter returns to 0 after it is set.) 2: Offset adjustment not required. (The parameter returns to 0 after it is set.)	Default: 0 Range: 0 to 2
C7-44 (112BH)	Gain for Active Damping 3	Damping Gain 3	There is normally no need to change this parameter from the default value.	Default: 0.00 Min.: 0.00 Max.: 1.00

## B.2 Parameter Tables

No. (Address Hex)	Name	LCD Display	Description	Values
C7-47 (112EH)	Adjustment Reactor 1	L1 Compensation	There is normally no need to change this parameter from the default value. Set this parameter to the value that is specified by the manufacturer when using a filter such as the DC5.	Default: <2> Min.: 00.000 Max.: 65.000
C7-50 (113BH)	Operation Ready ON Delay Time	Conv READY delay	Sets the delay time to turn on the Operation Ready signal (H2-□□ = 6).	Default: 0 ms Min.: 0 ms Max.: 500 ms
C7-51 (113CH)	Adjustment Reactor 2	L2 Compensation	There is normally no need to change this parameter from the default value. Set this parameter to the value that is specified by the manufacturer when using a filter such as the DC5.	Default: <2> Min.: 00.000 Max.: 65.000

<1> This parameter is not available in model 4A0630.

<2> Default setting is dependent on parameter o2-04, Drive Model Selection.



### ◆ d: References

Reference parameters set the value of the DC bus voltage reference.



No. (Address Hex)	Name	LCD Display	Description	Values
<b>d8: DC Bus Voltage Reference</b>				
d8-01 (2B9H) 	DC Bus Voltage Reference	Vpn Volt Ref	Sets the DC bus voltage reference in volts. Yaskawa recommends setting a value that is 1.5 times the set value of the Power Supply Voltage (U1-54).	200 V Class Default: 330 V Range: 300 V to 360 V 400 V Class Default: 660 V Range: 600 V to 730 V

### ◆ F: Options

F parameters program the converter for communication options and to function with option cards.

No. (Address Hex)	Name	LCD Display	Description	Values
<b>F4: Analog Monitor Card (AO-A3)</b>				
F4-01 (391H)	Terminal V1 Monitor Selection	AO Ch1 Select	Sets the monitor signal for output from terminal V1. Set this parameter to the last three digits of the desired U□-□□ monitor. Some U parameters are available only in certain control modes.	Default: 0 Min.: 000 Max.: 408
F4-02 (392H) 	Terminal V1 Monitor Gain	AO Ch1 Gain	Sets the gain for voltage output via terminal V1.	Default: 100.0% Min.: -999.9% Max.: 999.9%
F4-03 (393H)	Terminal V2 Monitor Selection	AO Ch2 Select	Sets the monitor signal for output from terminal V2. Set this parameter to the last three digits of the desired U□-□□ monitor. Some U parameters are available only in certain control modes.	Default: 0 Min.: 000 Max.: 408
F4-04 (394H) 	Terminal V2 Monitor Gain	AO Ch2 Gain	Sets the gain for voltage output via terminal V2.	Default: 50.0% Min.: -999.9% Max.: 999.9%



No. (Address Hex)	Name	LCD Display	Description	Values
F4-05 (395H) 	Terminal V1 Monitor Bias	AO Ch1 Bias	Sets the amount of bias added to the voltage output via terminal V1.	Default: 0.0% Min.: -999.9% Max.: 999.9%
F4-06 (396H) 	Terminal V2 Monitor Bias	AO Ch2 Bias	Sets the amount of bias added to the voltage output via terminal V2.	Default: 0.0% Min.: -999.9% Max.: 999.9%
F4-07 (397H)	Terminal V1 Signal Level	AO Opt Level Ch1 0: 0-10 VDC 1: -10 +10 VDC	0: 0 to 10 V 1: -10 to 10 V	Default: 0 Min.: 0 Max.: 1
F4-08 (398H)	Terminal V2 Signal Level	AO Opt Level Ch2 0: 0-10 VDC 1: -10 +10 VDC	0: 0 to 10 V 1: -10 to 10 V	Default: 0 Min.: 0 Max.: 1
<b>F5: Digital Output Card (DO-A3)</b>				
F5-01 (399H)	Terminal P1-PC Output Selection	DO Ch1 Select	Sets the function for contact output terminals M1-M2, M3-M4, and photocoupler output terminals P1 through P6.	Default: F Min.: 0 Max.: 160
F5-02 (39AH)	Terminal P2-PC Output Selection	DO Ch2 Select		Default: F Min.: 0 Max.: 160
F5-03 (39BH)	Terminal P3-PC Output Selection	DO Ch3 Select		Default: F Min.: 0 Max.: 160
F5-04 (39CH)	Terminal P4-PC Output Selection	DO Ch4 Select		Default: F Min.: 0 Max.: 160
F5-05 (39DH)	Terminal P5-PC Output Selection	DO Ch5 Select		Default: F Min.: 0 Max.: 160
F5-06 (39EH)	Terminal P6-PC Output Selection	DO Ch6 Select		Default: F Min.: 0 Max.: 160
F5-07 (39FH)	Terminal M1-M2 Output Selection	DO Ch7 Select		Default: F Min.: 0 Max.: 160
F5-08 (3A0H)	Terminal M3-M4 Output Selection	DO Ch8 Select		Default: F Min.: 0 Max.: 160
<b>F6: Communication Option Card</b>				
For details on a specific option card, refer to the instruction manual for the option card.				

## B.2 Parameter Tables

### ◆ H: Multi-Function Terminals

H parameters assign functions to the multi-function input and output terminals.

No. (Address Hex)	Name	LCD Display	Description	Values
<b>H1: Multi-Function Digital Inputs</b>				
H1-01 (438H)	Multi-Function Digital Input Terminal S1 Function Selection	Term S1 Func Sel	Assigns a function to the multi-function digital inputs S1 to S8. <b>Note:</b> Set unused terminals to F.	Default: 4B Min.: 1 Max.: 67
H1-02 (439H)	Multi-Function Digital Input Terminal S2 Function Selection	Term S2 Func Sel		Default: 4C Min.: 1 Max.: 67
H1-03 (400H)	Multi-Function Digital Input Terminal S3 Function Selection	Term S3 Func Sel		Default: 24H Min.: 0 Max.: 67
H1-04 (401H)	Multi-Function Digital Input Terminal S4 Function Selection	Term S4 Func Sel		Default: 14H Min.: 0 Max.: 67
H1-05 (402H)	Multi-Function Digital Input Terminal S5 Function Selection	Term S5 Func Sel		Default: F Min.: 0 Max.: 67
H1-06 (403H)	Multi-Function Digital Input Terminal S6 Function Selection	Term S6 Func Sel		Default: F Min.: 0 Max.: 67
H1-07 (404H)	Multi-Function Digital Input Terminal S7 Function Selection	Term S7 Func Sel		Default: F Min.: 0 Max.: 67
H1-08 (405H)	Multi-Function Digital Input Terminal S8 Function Selection	Term S8 Func Sel		Default: 8H Min.: 0 Max.: 67

<b>H1 Multi-Function Digital Input Selections</b>				
H1-□□ Setting	Function	LCD Display	Description	
1	LOCAL/REMOTE selection	Local/Remote Sel	Open: REMOTE (parameter settings determine the source of the frequency Reference 1 or 2 (b1-01, b1-02 or b1-15, b1-16) Closed: LOCAL, Frequency reference and Run command are input from the digital operator	
8	Baseblock command (N.O.)	Ext BaseBlk N.O.	Closed: No converter output	
9	Baseblock command (N.C.)	Ext BaseBlk N.C.	Open: No converter output	
C	Analog terminal input selection	Term A2 Enable	Open: Function assigned by H3-14 is disabled. Closed: Function assigned by H3-14 is enabled.	
F	Through mode	Term Not Used	Select this setting when using the terminal in a pass-through mode.	
14	Fault reset	Fault Reset	Closed: Resets faults if the cause is cleared and the Run command is removed.	
18	Timer function input	Timer function	Triggers the timer set up by parameters b4-01 and b4-02. Must be set in conjunction with the timer function output (H2-□□ = 12).	

H1 Multi-Function Digital Input Selections			
H1-□□ Setting	Function	LCD Display	Description
1B	Program lockout	Program Lockout	Open: Parameters cannot be edited (except for U1-01 if the reference source is assigned to the digital operator). Closed: Parameters can be edited and saved.
24 to 27 2C to 2F	External fault	External fault 24: NO/ Always Det, Coast to Stop 25: NC/Always Det, Coast to Stop 26: NO/During RUN, Coast to Stop 27: NC/During RUN, Coast to Stop 2C: NO/Always Det, Alarm Only 2D: NC/Always Det, Alarm Only 2E: NO/ During RUN, Alarm Only 2F: NC/During RUN, Alarm Only	24: N.O., Always detected, coast to stop 25: N.C., Always detected, coast to stop 26: N.O., During run, coast to stop 27: N.C., During run, coast to stop 2C: N.O., Always detected, alarm only (continue running) 2D: N.C., Always detected, alarm only (continue running) 2E: N.O., During run, alarm only (continue running) 2F: N.C., During run, alarm only (continue running)
47	Node Setup	Node SetUp	Closed: Node setup for SI-S3 enabled.
4B	Run Command (2-wire Sequence)	Run Command3	Closed: Run <b>Note:</b> To start operation, close the Stop Command (4C) and then open the Run Command signal. After operation has started, it will continue even if the Run Command signal is opened.
4C	Stop Command (2-wire Sequence)	Stop Command3	Open: Stop. <b>Note:</b> To stop operation, open the Stop Command signal.
67	Communications test mode	Comm Test Mode	Tests the MEMOBUS/Modbus RS-422/RS-485 interface. Displays "PASS" if the test completes successfully.





No. (Address Hex)	Name	LCD Display	Description	Values
<b>H2: Multi-Function Relay Outputs</b>				
H2-01 (40BH)	Terminal M1-M2 function selection (relay)	M1-M2 Func Sel	Refer to <i>H2 Multi-Function Relay Output Settings on page 187</i> for a description of setting values. <b>Note:</b> Set unused terminals to F.	Default: 25H Min.: 0 Max.: 160
H2-02 (40CH)	Terminal M3-M4 Function Selection (Relay)	P1/PC Func Sel		Default: 26H Min.: 0 Max.: 160
H2-03 (40DH)	Terminal M5-M6 Function Selection (Relay)	P2/PC Func Sel		Default: 6H Min.: 0 Max.: 160
H2-06 (437H)	kWh Monitor Pulse Output Unit Selection	Pwr Mon Unit Sel 1: 1 kWh units 2: 10 kWh units 3: 100 kWh units 4: 1000 kWh units	Select the output unit of the multi-function contact when H2-01 to H2-03 is set to 39 and 3A.  1: 1 kWh Units 2: 10 kWh Units 3: 100 kWh Units 4: 1000 kWh Units	Default: 1 Min.: 1 Max.: 4

H2 Multi-Function Relay Output Settings			
H2-□□ Setting	Function	LCD Display	Description
0	During run	During RUN 1	Closed: A Run command is active or voltage is output.

## B.2 Parameter Tables





H2 Multi-Function Relay Output Settings			
H2-□□ Setting	Function	LCD Display	Description
6	Ready	Drive Ready	Closed: Power up is complete and the converter is ready to accept a Run command.
7	DC bus undervoltage	DC Bus Undervolt	Closed: DC bus voltage is below the Uv trip level set in L2-05.
8	During baseblock (N.O.)	BaseBlk 1	Closed: Converter has entered the baseblock state (no output voltage).
E	Fault	Fault	Closed: Fault occurred.
F	Through mode	Not Used	Set this value when using the terminal in the pass-through mode.
10	Minor fault	Minor Fault	Closed: An alarm has been triggered.
11	Fault reset command active	Reset Cmd Active	Closed: A command has been entered to clear a fault via the input terminals or from the serial network.
12	Timer output	Timer Output	Closed: Timer output.
1B	During baseblock (N.C.)	BaseBlk 2	Open: Converter has entered the baseblock state (no output voltage).
1D	During Regeneration	Regenerating	Closed: Motor is regenerating energy into the converter.
1E	Restart enabled	Dur Flt Restart	Closed: An automatic restart is performed
20	Drive overheat pre-alarm (oH)	OH Prealarm	Closed: Heatsink temperature exceeds the parameter L8-02 value.
24	Fuse Blowout Detection	FUA/FUD Detect	Closed: Fuse burnout detected.
25	During Run 1	During RUN 1	Closed: The drive is ready to operate.
26	During MC ON	MC On	Closed: The magnetic contactor is closed.
27	Converter Overload Warning (oL2)	OL2 Pre-alarm	Closed: There is an overload warning.
2F	Maintenance Period	Maintenance	Closed: It is time to perform maintenance on the cooling fan, electrolytic capacitor, and inrush prevention relay.
30	During Motoring Limit	Torque Limit	Closed: When the motoring limit has been reached.
39	Power Consumption	Pulse Output Energy Pulse Out	Output units are determined by H2-06. Outputs a pulse every 200 ms to indicate the kWh count.
3A	Regenerated Power	Pulse Output RegEn Pulse Out	Outputs a pulse to indicate the regenerated power.
3B	Alarm 2	Minor Fault 2	Closed: Alarm occurred (excluding Uv, AUv, Fdv, SrC, and PAUv). <b>Note:</b> This setting is available in converter software versions PRG:902003 or later.
3C	LOCAL/REMOTE status	Local	Open: REMOTE Closed: LOCAL
4D	oH Pre-alarm time limit	OH Pre-Alarm	Closed: oH pre-alarm time limit has passed.
60	Internal cooling fan alarm	Fan Alm Det	Closed: Internal cooling fan alarm
100 to 160	Function 0 to 60 with inverse output	–	Inverts the output switching of the multi-function output functions. Set the last two digits of 1□□ to reverse the output signal of that specific function.

No. (Address Hex)	Name	LCD Display	Description	Values
<b>H3: Multi-Function Analog Inputs</b>				
H3-01 (410H)	Terminal A1 Signal Level Selection	Term A1 Level 0: 0-10V, (LowLim=0) 1: 0-10V, (BipolRef)	0: 0 to 10 V 1: -10 to 10 V	Default: 0 Min.: 0 Max.: 1
H3-02 (434H)	Terminal A1 Function Selection	Term A1 FuncSel	Sets the function of terminal A1.	Default: F Min.: F Max.: 19
H3-03 (411H) 	Terminal A1 Gain Setting	Terminal A1 Gain	Sets the level of the input value selected in H3-02 when 10 V is input at terminal A1.	Default: 100.0% Min.: -999.9% Max.: 999.9%

No. (Address Hex)	Name	LCD Display	Description	Values
H3-04 (412H) 	Terminal A1 Bias Setting	Terminal A1 Bias	Sets the level of the input value selected in H3-02 when 0 V is input at terminal A1.	Default: 0.0% Min.: -999.9% Max.: 999.9%
H3-05 (413H)	Terminal A3 Signal Level Selection	Term A3 Signal 0: 0-10V (LowLim=0) 1: 0-10V (BipolRef)	0: 0 to 10 V 1: -10 to 10 V	Default: 0 Min.: 0 Max.: 1
H3-06 (414H)	Terminal A3 Function Selection	Terminal A3 Sel	Sets the function of terminal A3.	Default: F Min.: F Max.: 19
H3-07 (415H) 	Terminal A3 Gain Setting	Terminal A3 Gain	Sets the level of the input value selected in H3-06 when 10 V is input at terminal A3.	Default: 100.0% Min.: -999.9% Max.: 999.9%
H3-08 (416H) 	Terminal A3 Bias Setting	Terminal A3 Bias	Sets the level of the input value selected in H3-06 when 0 V is input at terminal A3.	Default: 0.0% Min.: -999.9% Max.: 999.9%
H3-09 (417H)	Terminal A2 Signal Level Selection	Term A2 Level 0: 0-10V, (LowLim=0) 1: 0-10V, (BipolRef) 2: 4-20 mA 3: 0-20 mA	0: 0 to 10 V 1: -10 to 10 V 2: 4 to 20 mA 3: 0 to 20 mA <b>Note:</b> Use DIP switch S1 to set input terminal A2 for a current or a voltage input signal.	Default: 2 Min.: 0 Max.: 3
H3-10 (418H)	Terminal A2 Function Selection	Term A2 FuncSel	Sets the function of terminal A2.	Default: F Min.: F Max.: 19
H3-11 (419H) 	Terminal A2 Gain Setting	Terminal A2 Gain	Sets the level of the input value selected in H3-10 when 10 V (20 mA) is input at terminal A2.	Default: 100.0% Min.: -999.9% Max.: 999.9%
H3-12 (41AH) 	Terminal A2 Bias Setting	Terminal A2 Bias	Sets the level of the input value selected in H3-10 when 0 V (0 or 4 mA) is input at terminal A2.	Default: 0.0% Min.: -999.9% Max.: 999.9%
H3-13 (41BH)	Analog Input Filter Time Constant	A1/A2 Filter T	Sets a primary delay filter time constant for terminals A1, A2, and A3. Used for electrical noise filtering.	Default: 0.03 s Min.: 0.00 s Max.: 2.00 s
H3-14 (41CH)	Analog Input Terminal Enable Selection	A1/A2 Sel 1: A1 Available 2: A2 Available 3: A1/A2 Available 4: A3 Available 5: A1/A3 Available 6: A2/A3 Available 7: All Available	Determines which analog input terminals will be enabled when a digital input programmed for “Analog input enable” (H1-□□ = C) is activated. 1: Terminal A1 only 2: Terminal A2 only 3: Terminals A1 and A2 only 4: Terminal A3 only 5: Terminals A1 and A3 6: Terminals A2 and A3 7: All terminals enabled	Default: 7 Min.: 1 Max.: 7

H3 Analog Output Settings			
H3-□□ Setting	Function	LCD Display	Description
F	Through mode	Through mode	Set this value when using the terminal in the pass-through mode.
10	Power Supply Side Active Current Limit	Motoring I Limit	10 V = Converter rated current
12	Regeneration side Active Current Limit	Regen I limit	10 V = Converter rated current
19	Voltage Reference	DC V Reference	10 V = Maximum value in d8-01

## B.2 Parameter Tables

No. (Address Hex)	Name	LCD Display	Description	Values
<b>H4: Analog Outputs</b>				
H4-01 (41DH)	Terminal FM Monitor Selection	Term FM FuncSel	Selects the data to be output through terminal FM. Set the desired monitor parameter to the digits available in U□-□□. For example, enter "153" for U1-53.	Default: 157 Min.: 000 Max.: 408
H4-02 (41EH) 	Terminal FM Monitor Gain	Terminal FM Gain	Sets the signal level at terminal FM that is equal to 100% of the selected monitor value.	Default: 100.0% Min.: -999.9% Max.: 999.9%
H4-03 (41FH) 	Terminal FM Monitor Bias	Terminal FM Bias	Sets the signal level at terminal FM that is equal to 0% of the selected monitor value.	Default: 0.0% Min.: -999.9% Max.: 999.9%
H4-04 (420H)	Terminal AM Monitor Selection	Terminal AM Sel	Selects the data to be output through terminal AM. Set the desired monitor parameter to the digits available in U□-□□. For example, enter "153" for U1-53.	Default: 155 Min.: 000 Max.: 408
H4-05 (421H) 	Terminal AM Monitor Gain	Terminal AM Gain	Sets the signal level at terminal AM that is equal to 100% of the selected monitor value.	Default: 50.0% Min.: -999.9% Max.: 999.9%
H4-06 (422H) 	Terminal AM Monitor Bias	Terminal AM Bias	Sets the signal level at terminal AM that is equal to 0% of the selected monitor value.	Default: 0.0% Min.: -999.9% Max.: 999.9%
H4-07 (423H)	Terminal FM Signal Level Selection	Level Select1 0: 0-10 VDC 1: -10 +10 VDC 2: 4-20 mA	Sets the signal level at terminal FM. 0: 0 to 10 V 1: -10 to 10 V 2: 4 to 20 mA	Default: 0 Min.: 0 Max.: 1
H4-08 (424H)	Terminal AM Signal Level Selection	AO Level Select2 0: 0-10 VDC 1: -10 +10 VDC 2: 4-20 mA	Sets the signal level at terminal AM. 0: 0 to 10 V 1: -10 to 10 V 2: 4 to 20 mA	Default: 0 Min.: 0 Max.: 1

### ◆ L: Protection Function

Protection function parameters set momentary power loss processing, fault retries, and hardware protection.

No. (Address Hex)	Name	LCD Display	Description	Values
<b>L2: Momentary Power Loss Ride-Thru</b>				
L2-01 (485H)	Momentary Power Loss Operation Selection	PwrL Selection 0: Disabled 1: Enbl with Timer 2: Enbl whl CPU act	0: Disabled. Converter trips on Uv1 fault when power is lost. 1: Recover within the time set in L2-02. Uv1 will be detected if power loss is longer than L2-02. 2: Recover as long as CPU has power. Uv1 is not detected. <b>Note:</b> Even if L2-01 is set to 1 or 2, the converter may detect a fault when momentary-power-loss occurs during regeneration or during no load.	Default: 0 Min.: 0 Max.: 2
L2-02 (486H)	Momentary Power Loss Ride-Thru Time	PwrL Ridethru t	Sets the Power Loss Ride-Thru time. Enabled only when L2-01 = 1 or 3.	Default: <-> Min.: 0.0 s Max.: 25.5 s

No. (Address Hex)	Name	LCD Display	Description	Values
L2-05 (489H)	Undervoltage Detection Level (Uv)	PUV Det Level	There is normally no need to change this parameter from the default value.	200 V Class Default: 190 V Min.: 150 V Max.: 210 V 400 V Class Default: 380 V Min.: 300 V Max.: 420 V
L2-21 (4D5H)	AUv Detection Level	AC UV Level	Sets the undervoltage detection level for power supply voltage (AC) in volts.	200 V Class Default: 150 V Min.: 100 V Max.: 200 V 400 V Class Default: 300 V Min.: 200 V Max.: 400 V
L2-35 (11E0H)	Momentary vrE Detection Level	V Resonance Lvl	There is normally no need to change this parameter from the default value. Protects the converter against momentary increase of power supply voltage caused by power supply resonance or other factors. A vrE is detected when the detected power supply voltage exceeds the value that is set in L2-35. Set the effective value in L2-35. Faults are not detected if you set this parameter to 0.	200 V Class Default: 277 V Min.: 0 V Max.: 400 V 400 V Class Default: 554 V Min.: 0 V Max.: 800 V
L2-36	Power Supply Resonance Detection Time	vrE Detect time	There is normally no need to change this parameter from the default value. The converter will stop temporarily, if a power supply resonance is detected (vrE).	Default: 300 ms Min.: 150 ms Max.: 1000 ms
L2-37	Number of Power Supply Resonance Detection	vrE Detect Count	The converter will stop completely, if a power supply resonance is detected (vrE) within the time set in L2-36 in milliseconds for the number of time that is set in L2-37.	Default: 3 Min.: 1 Max.: 10
<b>L5: Fault Restart</b>				
L5-01 (49EH)	Number of Auto Restart Attempts	Num of Restarts	Sets the number of times the converter may attempt to restart after the following faults occur: GF, oC, oH1, oL2, ov, Uv1.	Default: 0 time Min.: 0 time Max.: 10 times
L5-02 (49FH)	Auto Restart Fault Output Operation Selection	Restart Sel 0: Flt Outp Disabld 1: Flt Outp Enabled	0: Fault output not active. 1: Fault output active during restart attempt.	Default: 0 Min.: 0 Max.: 1
L5-04 (4A0H)	Fault Reset Interval Time	Flt Reset Wait T	Sets the amount of time to wait between performing fault restarts.	Default: 10.0 s Min.: 0.5 s Max.: 600.0 s
L5-05 (46CH)	Fault Reset Operation Selection	Fault Reset Sel 0: Continuous 1: Use L5-04 Time	0: Continuously attempt to restart while incrementing restart counter only at a successful restart. 1: Attempt to restart with the interval time set in L5-04 and increment the restart counter with each attempt.	Default: 0 Min.: 0 Max.: 1
<b>L7: Motoring Limit</b>				
L7-25 (628H)	Active Current Limit at Power Supply Side	Motoring I Limit	Sets the limit for the active current at the power supply side.	Default: 200% Min.: 0% Max.: 200%
L7-26 (629H)	Active Current Limit at Regeneration Side	Regen I Limit	Sets the limit for the active current at the regeneration side.	Default: 200% Min.: 0% Max.: 200%

## B.2 Parameter Tables

No. (Address Hex)	Name	LCD Display	Description	Values
<b>L8: Drive Protection</b>				
L8-02 (4AEH)	Overheat Alarm Level	OH Pre-Alarm Lvl	An overheat alarm occurs when heatsink temperature exceeds the L8-02 level.	Default: <2> Min.: 50°C Max.: 150°C
L8-03 (4AFH)	Overheat Pre-Alarm Operation Selection	OH Pre-Alarm Sel 1: Ramp to stop 3: Alarm only	1: Ramp to stop. A fault is triggered. 3: Continue operation. An alarm is triggered.	Default: 3 Min.: 1 Max.: 3
L8-09 (4B5H)	Output Ground Fault Detection Selection	Grnd Flt Det Sel 0: Disabled 1: Enabled	0: Disabled 1: Enabled	Default: <2> Min.: 0 Max.: 1
L8-10 (4B6H)	Heatsink Cooling Fan Operation Selection	Fan On/Off Sel 0: Dur Run (OffDly) 1: Always On	0: During run only. Fan operates only during run for L8-11 seconds after stop. 1: Fan always on. Cooling fan operates whenever the converter is powered up.	Default: 0 Min.: 0 Max.: 1
L8-11 (4B7H)	Heatsink Cooling Fan Off Delay Time	Fan Delay Time	Sets a delay time to shut off the cooling fan after the Run command is removed when L8-10 = 0.	Default: 60 s Min.: 0 s Max.: 300 s
L8-12 (4B8H)	Ambient Temperature Setting	Ambient Temp	Enter the ambient temperature. This value adjusts the oL2 detection level.	Default: 40°C Min.: -10°C Max.: 50°C
L8-35 (4ECH)	Installation Method Selection	Installation Sel 0: IP00/OpenChassis 1: Side-by-Side 3: ExternalHeatsink	0: IP00/IP20/Open Type Enclosure 1: Side-by-Side Mounting 3: External Heatsink Installation	Default: <2> Min.: 0 Max.: 3
L8-41 (4F2H)	High Current Alarm Selection	High Cur Alm Sel 0: Disabled 1: Enabled	0: Disabled 1: Enabled. An alarm is triggered at output currents above 150% of converter rated current.	Default: 0 Min.: 0 Max.: 1
L8-65 (66FH)	Power Supply Fault Detection Selection	Vpn Ripple Sel 0: Disabled 1: Coast to Stop 2: Alarm Only	There is normally no need to change this parameter from the default value. Monitors the ripple of DC BUS voltage and detects Input Power Supply Fault(PF2) when the ripple is too bad. 0: No detection 1: Stop operation (fault) 2: Continue operation (minor fault)	Default: 0 Min.: 0 Max.: 2
L8-66 (670H)	Power Supply Fault Detection Voltage Level	Vpn Ripple Lvl	There is normally no need to change this parameter from the default value. The main circuit DC voltage ripple is monitored in a cycle of 200 ms. If the difference between the maximum and minimum values of the ripple exceeds the value that is set in L8-66 for the number of times that is set in L8-67, a power supply fault is detected.	200V Class Default: <2> Min.: 1 Max.: 200 400V Class Default: <2> Min.: 1 Max.: 200
L8-67 (671H)	Number of Times of Power Supply Fault for Detection	Vpn Ripple Cnt		Default: 5 Min.: 1 Max.: 10
L8-69 (673H)	Input Phase Loss Protection Selection 3	AC Phase Imb Det 0: Disabled 1: Enabled	Sets whether to enable or disable the protective function for the converter when there is an input phase loss. 0: Disabled 1: Enabled (Detect input phase loss and power supply imbalance.)	Default: 1 Min.: 0 Max.: 1
L8-78 (2CCH)	Module Phase Loss (LF3) Protection	LF3 Det Sel 0: Disabled 1: Enabled	Enables phase loss protection for the input terminals R/L1, S/L2, T/L3 or R1/L11, S1/L21, T1/L31. 0: Disable 1: Enable <b>Note:</b> This parameter is available only in model 4A0630.	Default: 1 Min.: 0 Max.: 1





No. (Address Hex)	Name	LCD Display	Description	Values
L9-08	DC5 Converter Unit Replacement Selection	Replacement DC5	Select when replacing DC5 with D1000, using the peripheral devices as is. 0: Disable 1: Enable	Default: 0 Min.: 0 Max.: 1
L9-09	DC3 Converter Unit Replacement Selection	Replacement DC3	Select when replacing DC3 with D1000, using the peripheral devices as is. 0: Disable 1: Enable	Default: 0 Min.: 0 Max.: 1

<> Default setting is dependent on parameter o2-04, Drive Model Selection.

### ◆ o: Operator-Related Settings

The o parameters set up the digital operator displays.

No. (Address Hex)	Name	LCD Display	Description	Values
<b>o1: Digital Operator Display Selection</b>				
o1-01 (500H) 	Drive Mode converter Monitor Selection	User Monitor Sel	When the power supply is turned on, the operator will display the following in order: DC Bus Voltage Reference, DC Bus Voltage Feedback, DC Current Reference, Power Supply Voltage, Power Supply Frequency, and U1-□□. The o1-01 parameter sets the item to display instead of the output voltage. The o1-02 parameter sets the item to display at power up.	Default: 158 (Monitor U1-58) Min.: 110 Max.: 914
o1-02 (501H) 	User Monitor Selection after Power Up	Power-On Monitor 1: Frequency Ref 2: FWD/REV 3: Output Freq 4: Output Current 5: User Monitor	Selects the information displayed on the digital operator when the power is turned on. 1: Output Voltage Reference 2: Output Voltage Feedback 3: Output Current 4: Input Voltage 5: User monitor item set in o1-01	Default: 1 Min.: 1 Max.: 5
o1-05 (504H)  <7>	LCD Contrast Control	LCD Contrast	Sets the brightness of the LCD operator.	Default: 3 Min.: 0 Max.: 5
<b>o2: Digital Operator Keypad Functions</b>				
o2-01 (505H)	LO/RE Key Function Selection	LO/RE Key	0: Disabled 1: Enabled. LO/RE key switches between LOCAL and REMOTE operation.	Default: 1 Min.: 0 Max.: 1
o2-02 (506H)	STOP Key Function Selection	Oper STOP Key 0: Disabled 1: Enabled	0: Disabled. STOP key is disabled in REMOTE operation. 1: Enabled. STOP key is always enabled.	Default: 1 Min.: 0 Max.: 1
o2-03 (507H)	User Parameter Default Value	User Default Sel 0: No Change 1: Save User Init 2: Clear User Init	0: No change. 1: Set defaults. Saves parameter settings as default values for a User Initialization. 2: Clear all. Clears the default settings that have been saved for a User Initialization.	Default: 0 Min.: 0 Max.: 2
o2-04 (508H)	Unit Model Selection	Inverter Model #	Enter the converter model. Setting required only if installing a new control board.	Default: Determined by converter model. Min.: – Max.: –

Parameter List

## B.2 Parameter Tables

No. (Address Hex)	Name	LCD Display	Description	Values
o2-06 (50AH)	Operation Selection when Digital Operator is Disconnected	Oper Discon Det 0: Disabled 1: Enabled	Determines the operation when the digital operator is disconnected. 0: The converter continues operating if the digital operator is disconnected. 1: A fault is triggered (oPr) and the motor coasts to stop.	Default: 1 Min.: 0 Max.: 1
o2-09 (50DH)	Reserved	–	–	–
o2-21 (81AH)	converter Check	US signal check 0: Normal 1: Start	Sets the operation for Converter Capacity Setting Fault (oPE01). Set this parameter to 1 to reset an oPE01 fault without cycling the power supply. 0: Standard 1: Recheck converter (The parameter returns to 0 after it is set.)	Default: 0 Min.: 0 Max.: 1
<b>o3: Copy Function</b>				
o3-01 (515H)	Copy Function Selection	COPY SELECT 0: COPY SELECT 1: INV→OP READ 2: OP→INV WRITE 3: OP←→INV VERIFY	0: No action 1: Read parameters from the converter, saving them onto the digital operator. 2: Copy parameters from the digital operator, writing them to the converter. 3: Verify parameter settings on the converter to check if they match the data saved on the operator.	Default: 0 Min.: 0 Max.: 3
o3-02 (516H)	Copy Allowed Selection	Read Allowable 0: Disabled 1: Enabled	0: Read operation prohibited 1: Read operation allowed	Default: 0 Min.: 0 Max.: 1
<b>o4: Maintenance Monitor Settings</b>				
o4-01 (50BH)	Cumulative Operation Time Setting	DrvElapsTimeCnt	Sets the value for the cumulative operation time of the converter in units of 10 h.	Default: 0 Min.: 0 Max.: 9999
o4-02 (50CH)	Cumulative Operation Time Selection	ElapsTimeCntSet 0: Power-On Time 1: Running Time	0: Logs power-on time 1: Logs operation time when the converter output is active (output operation time).	Default: 0 Min.: 0 Max.: 1
o4-03 (50EH)	Cooling Fan Operation Time Setting	FanElapsTimeCn	Sets the value of the fan operation time monitor U4-03 in units of 10 h.	Default: 0 Min.: 0 Max.: 9999
o4-05 (51DH)	Capacitor Maintenance Setting	BusCap Maint Set	Sets the value of the Maintenance Monitor for the capacitors. See U4-05 to check when the capacitors may need to be replaced.	Default: 0% Min.: 0% Max.: 150%
o4-07 (523H)	DC Bus Pre-Charge Relay Maintenance Setting DC Bus Pre-Charge Relay Maintenance Setting	ChrgCircMaintSet	Sets the value of the Maintenance Monitor for the soft charge bypass relay. See U4-06 to check when the bypass relay may need to be replaced.	Default: 0% Min.: 0% Max.: 150%
o4-11 (510H)	U2, U3 Initialization	Fault Data Init 0: No Reset 1: Reset	0: U2-□□ and U3-□□ monitor data is not reset when the converter is initialized (A1-03). 1: U2-□□ and U3-□□ monitor data is reset when the converter is initialized (A1-03).	Default: 0 Min.: 0 Max.: 1
o4-12 (512H)	kWh Monitor Initialization	kWh Monitor Init 0: No Reset 1: Reset	0: U4-10 and U4-11 monitor data is not reset when the converter is initialized (A1-03). 1: U4-10 and U4-11 monitor data is reset when the converter is initialized (A1-03).	Default: 0 Min.: 0 Max.: 1
o4-13 (528H)	Number of Run Commands Counter Initialization	Run Counter Init 0: No Reset 1: Reset	0: Number of Run commands counter is not reset when the converter is initialized (A1-03). 1: Number of Run commands counter is reset when the converter is initialized (A1-03).	Default: 0 Min.: 0 Max.: 1

No. (Address Hex)	Name	LCD Display	Description	Values
04-19 (113AH)	Power Unit Price	Cost per 1 kWh	This parameter is used to calculate the power rate that is displayed for User Monitors U9-07 through U9-14. Set the price per 1 kWh.	Default: 000.00 Min.: 000.00 Max.: 650.00

<7> Parameter is available in software versions PRG: 2003 and later (PRG: 3010 and later in 4A0630).

◆ **U: Monitors**

Monitor parameters allow the user to view converter status, fault information, and other data concerning converter operation.

No. (Address Hex)	Name	LCD Display	Description	Analog Output Level	Unit
<b>U1: Operation Status Monitors</b>					
U1-10 (49H)	Input Terminal Status	Input Term Sts	Displays the input terminal status. U1 - 10=00000000 1: ON 0: OFF 	No signal output available	—
U1-11 (4AH)	Output Terminal Status	Output Term Sts	Displays the output terminal status. U1 - 11=00000000 1: ON 0: OFF 	No signal output available	—
U1-12 (4BH)	Drive Status	Int Ctl Sts 1	Verifies the converter operation status. U1 - 12=00000000 	No signal output available	—
U1-13 (4EH)	Terminal A1 Input Level	Term A1 Level	Displays the signal level to analog input terminal A1.	10 V: 100%	0.1%

Parameter List

B

## B.2 Parameter Tables

No. (Address Hex)	Name	LCD Display	Description	Analog Output Level	Unit
U1-14 (4FH)	Terminal A2 Input Level	Term A2 Level	Displays the signal level to analog input terminal A2.	10 V: 100%	0.1%
U1-15 (50H)	Terminal A3 Input Level	Term A3 Level	Displays the signal level to analog input terminal A3.	10 V: 100%	0.1%
U1-18 (61H)	oPE Fault Parameter	OPE Error Code	Displays the parameter number that caused the oPE02 or oPE08 operation error.	No signal output available	–
U1-19 (66H)	MEMOBUS/Modbus Error Code	Transmit Err	Displays the contents of a MEMOBUS/Modbus error.  <div style="text-align: center;"> <p>U1 - 19 = 00000000</p> </div>	No signal output available	–
U1-25 (4DH)	Software Number (Flash)	CPU 1 SW Number	FLASH ID	No signal output available	–
U1-26 (5BH)	Software No. (ROM)	CPU 2 SW Number	ROM ID	No signal output available	–
U1-27 (7A8H)	Message ID (OPR)	MessageID (OPR)	Shows the message ID number for OPE.	No signal output available	–
U1-28 (7A9H)	Message ID (INV)	MessageID (INV)	Shows the message ID number for INV.	No signal output available	–
U1-29 (7AAH)	Software No. (PWM)	CPU 3 SW Number	PWM ID <b>Note:</b> This parameter is available in 4A0630.	No signal output available	–
U1-51 (1080H)	DC Bus Voltage Reference (Before SFS)	DC V Command	Shows the DC bus voltage reference.	200 V Class 10 V: 400 V 400 V Class 10 V: 800 V	1 V
U1-52 (1081H)	DC Bus Voltage Feedback	DC V Feedback	Shows the DC bus voltage feedback value.	200 V Class 10 V: 400 V 400 V Class 10 V: 800 V	1 V
U1-53 (1082H)	DC Bus Side Current	DC Current	Shows an estimated value of the bus current on the DC side.	10 V: Rated Output Current	1 A
U1-54 (1083H)	Power Supply Voltage	AC Voltage	Shows the power supply voltage.	200 V Class 10 V: 400 V 400 V Class 10 V: F800 V	1 V
U1-55 (1084H)	Power Supply Current	AC Current	Shows the current on the power supply side.	10 V: Rated Input Current	1 A
U1-56 (1085H)	DC Bus Side Power	DC Power	Shows the power on the DC side.	10 V: Rated power (output side)	1 kW
U1-57 (1086H)	Power Supply Side Power	AC Power	Shows the power on the power supply side.	10 V: Rated power (input side)	1 kW

No. (Address Hex)	Name	LCD Display	Description	Analog Output Level	Unit
U1-58 (1087H)	Power Supply Frequency	AC Frequency	Shows the frequency on the power supply side.	10 V: Rated Frequency	0.1 Hz
U1-59 (1088H)	Power Supply Current Reference	AC Current Ref	Shows the current reference on the power supply side.	10 V: Rated Input Current	1 A
U1-60 (1089H)	Power Factor	Power Factor	Shows the power factor.	10 V: 100%	1%
U1-61 (108AH)	Active Current	Active Current	Shows the active current.	10 V: 100.0%	0.1%
U1-62 (108BH)	Reactive Current	Reactive Current	Shows the reactive current.	10 V: 100.0%	0.1%
U1-63 (108CH)	DC Bus Voltage Reference (After SFS)	DC Volt SFS Out	Shows the DC bus voltage reference after the soft starter.	200 V Class 10 V: 400 V 400 V Class 10 V: 800 V	1 V
U1-64 (108DH)	Avr Input (Voltage Deviation)	AVR Input	Shows the Avr input.	200 V Class 10 V: 400 V 400 V Class 10 V: 800 V	1 V
U1-65 (108EH)	Avr Output	AVR Output	Shows the Avr output.	10 V: 100.0%	0.01%
U1-66 (108FH)	Control Voltage Reference (Vq)	Voltage Ref (Vq)	Shows the control voltage reference (Vq) in the converter for the current control on the power supply side.	200 V Class 10 V: 200 V 400 V Class 10 V: 400 V	1 V
U1-67 (1090H)	Control Voltage Reference (Vd)	Voltage Ref (Vd)	Shows the control voltage reference (Vd) in the converter for the current control on the power supply side.	200 V Class 10 V: 200 V 400 V Class 10 V: 400 V	1 V
U1-72 (1095H)	Input Power Supply Information	AC Supply Status	Shows information on the input power supply.  <div style="text-align: center;"> <p><b>U1-72=00000000</b></p> <ul style="list-style-type: none"> <li>└ Bit 0: AUv reset. (0: Not completed, 1: Reset)</li> <li>└ Bit 1: PF3 reset (0: Not completed, 1: Reset)</li> <li>└ Bit 2: Rated frequency detection (0: Not completed, 1: Completed)</li> <li>└ Bit 3: Phase order detection (0: Not completed, 1: Completed)</li> <li>└ Bit 4: Power supply established (0: Not completed, 1: Completed)</li> <li>└ Bit 5: Fdv detection (0: Not detected, 1: Detected)</li> <li>└ Bit 6: PF3 detection (0: Not detected, 1: Detected)</li> <li>└ Bit 7: Reserved.</li> </ul> </div>	No signal output available	–
<b>U2: Fault Trace</b>					
U2-01 (80H)	Current Fault	Current Fault	Displays the current fault.	No signal output available	–
U2-02 (81H)	Previous Fault	Last Fault	Displays the previous fault.	No signal output available	–
U2-11 (8AH)	Input Terminal Status at Previous Fault	Input Term Sts	Displays the input terminal status at the previous fault. Displayed as in U1-10.	No signal output available	–
U2-12 (8BH)	Output Terminal Status at Previous Fault	Output Term Sts	Displays the output status at the previous fault. Displays the same status displayed in U1-11.	No signal output available	–

## B.2 Parameter Tables

No. (Address Hex)	Name	LCD Display	Description	Analog Output Level	Unit
U2-13 (8CH)	Drive Operation Status at Previous Fault	Inverter Status	Displays the operation status of the converter at the previous fault. Displays the same status displayed in U1-12.	No signal output available	–
U2-14 (8DH)	Cumulative Operation Time at Previous Fault	Elapsed time	Displays the cumulative operation time at the previous fault.	No signal output available	1 h
U2-20 (8EH)	Heatsink Temperature at Previous Fault	Actual Fin Temp	Displays the temperature of the heatsink when the most recent fault occurred.	No signal output available	1°C
U2-28 (7FCH)	Malfunctioned Module	Fault Axis	Displays the module where the previous fault occurred as a decimal number. <b>Note:</b> This parameter is only available in 4A0630.	No signal output available	–
U2-51 (840H)	DC Bus Voltage Reference at Previous Fault (Before SFS)	DC V Command	Shows the DC Bus Voltage Reference.	No signal output available	1 V
U2-52 (841H)	DC Bus Voltage Feedback at Previous Fault	DC V Feedback	Shows the DC bus voltage feedback value.	No signal output available	1 V
U2-53 (842H)	DC Side Current at Previous Fault	DC Current	Shows the estimated current on the bus on the DC side.	No signal output available	1 A
U2-54 (843H)	Power Supply Voltage at Previous Fault	AC Voltage	Shows the power supply voltage.	No signal output available	1 V
U2-55 (844H)	Power Supply Side Current at Previous Fault	AC Current	Shows the current on the power supply side.	No signal output available	1 A
U2-56 (845H)	DC Side Power at Previous Fault	DC Power	Shows the power on the DC side.	No signal output available	1 kW
U2-57 (846H)	Power Supply Side Power at Previous Fault	AC Power	Shows the power on the power supply side.	No signal output available	1 kW
U2-58 (847H)	Power Supply Frequency at Previous Fault	AC Frequency	Shows the frequency on the power supply side.	No signal output available	0.1 Hz
U2-59 (848H)	Power Supply Side Current Reference at Previous Fault	AC Current Ref	Shows the current reference on the power supply side when the most recent fault occurred.	No signal output available	1 A
U2-60 (849H)	Power Factor at Previous Fault	Power Factor	Shows the power factor when the most recent fault occurred.	No signal output available	1%
U2-61 (84AH)	Active Current Reference at Previous Fault	Active Current	Shows the active current when the most recent fault occurred.	No signal output available	0.1%
U2-62 (84BH)	Reactive Current Reference at Previous Fault	Reactive Current	Shows the reactive current when the most recent fault occurred.	No signal output available	0.1%
U2-63 (84CH)	DC Bus Voltage Reference at Previous Fault (After SFS)	DC V SFS Level	Shows the DC bus voltage reference after the soft starter.	No signal output available	1 V

No. (Address Hex)	Name	LCD Display	Description	Analog Output Level	Unit
U2-64 (84DH)	Avr Input (Voltage Deviation) at Previous Fault	AVR Input	Shows the Avr input.	No signal output available	1 V
U2-65 (84EH)	Control Voltage Reference (Vq) at Previous Fault	Voltage Ref (Vq)	Shows the control voltage reference (Vq) when the most recent fault occurred.	No signal output available	1 V
U2-66 (84FH)	Control Voltage Reference (Vd) at Previous Fault	Voltage Ref (Vd)	Shows the control voltage reference (Vd) when the most recent fault occurred.	No signal output available	1 V
<b>U3: Fault History</b>					
U3-01 to U3-04 (90H to 93H)	First to 4th Most Recent Fault	Fault Message <input type="checkbox"/>	Displays the first to the fourth most recent faults.	No signal output available	–
U3-05 to U3-10 (804H to 809H)	5th to 10th Most Recent Fault	Fault Message <input type="checkbox"/>	Displays the fifth to the tenth most recent faults. After ten faults, data for the oldest fault is deleted. The most recent fault appears in U3-01, with the next most recent fault appearing in U3-02. The data is moved to the next monitor parameter each time a fault occurs.	No signal output available	–
U3-11 to U3-14 (94H to 97H)	Cumulative Operation Time at 1st to 4th Most Recent Fault	Elapsed Time <input type="checkbox"/>	Displays the cumulative operation time when the first to the fourth most recent faults occurred.	No signal output available	1 h
U3-15 to U3-20 (80EH to 813H)	Cumulative Operation Time at 5th to 10th Most Recent Fault	Elapsed Time <input type="checkbox"/>	Displays the cumulative operation time when the fifth to the tenth most recent faults occurred.	No signal output available	1 h
<b>U4: Maintenance Monitors</b>					
U4-01 (4CH) <4>	Cumulative Operation Time	Drv Elapsed Time	Displays the cumulative operation time of the converter. The value for the cumulative operation time counter can be reset in parameter o4-01. Use parameter o4-02 to determine if the operation time should start as soon as the power is switched on or only while the Run command is present. The maximum number displayed is 99999, after which the value is reset to 0.	No signal output available	1 h
U4-02 (75H)	Number of Run Commands	RUN Cmd Counter	Displays the number of times the Run command is entered. Reset the number of Run commands using parameter o4-13. This value will reset to 0 and start counting again after reaching 65535.	No signal output available	1 time
U4-03 (67H) <5>	Cooling Fan Operation Time	Fan Elapsed Time	Displays the cumulative operation time of the cooling fan. The default value for the fan operation time is reset in parameter o4-03. This value will reset to 0 and start counting again after reaching 99999.	No signal output available	1 h
U4-04 (7EH)	Cooling Fan Maintenance	Fan Life Mon	Displays main cooling fan usage time as a percentage of its expected performance life. Parameter o4-03 can be used to reset this monitor. Replace the fan when this monitor reaches 90%.	No signal output available	1%
U4-05 (7CH)	Capacitor Maintenance	Cap Life Mon	Displays main circuit capacitor usage time as a percentage of their expected performance life. Parameter o4-05 can be used to reset this monitor. Replace the capacitor when this monitor reaches 90%.	No signal output available	1%
U4-06 (7D6H)	Soft Charge Bypass Relay Maintenance	ChgCirc Life Mon	Displays the soft charge bypass relay maintenance time as a percentage of its estimated performance life. Parameter o4-07 can be used to reset this monitor. Replace the soft charge bypass relay when this monitor reaches 90%.	No signal output available	1%
U4-08 (68H)	Heatsink Temperature	Heatsink Temp	Displays the heatsink temperature.	10 V: 100°C	1°C
U4-09 (5EH)	LED Check	LED Oper Check	Lights all segments of the LED to verify that the display is working properly.	No signal output available	–
U4-13 (7CFH)	Peak Hold Current	Current PeakHold	Displays the highest current value that occurred during run.	No signal output available	1 A

## B.2 Parameter Tables

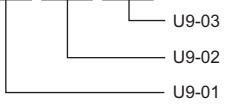
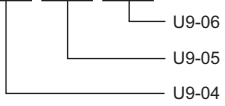
No. (Address Hex)	Name	LCD Display	Description	Analog Output Level	Unit
U4-18 (7DAH)	DC BUS Voltage Reference Source Selection	Reference Source	Displays the source for the DC BUS voltage reference as XY-nn. X: indicates which reference is used: 1 = Reference 1 (b1-01) Y-nn: indicates the reference source 0-01 = Digital operator 1-01 = Analog (terminal A1) 1-02 = Analog (terminal A2) 1-03 = Analog (terminal A3) 3-01 = MEMOBUS/Modbus communications 4-01 = Communication option card 8-01 = Depends on b1-18	No signal output available	–
U4-20 (7DCH)	Option DC voltage Reference	Option Freq Ref	Displays the DC bus voltage reference input by an option card (decimal).	0.01%	–
U4-35 (1042H)	Power Supply Module Undervoltage (Uv)	UV Alarm Axis	Displays the module where power supply Undervoltage (Uv) occurred in binary. <b>Note:</b> This setting is available only in model 4A0630.	No signal output available	–
U4-36 (1043H)	Power Supply Module Overvoltage (ov)	OV Alarm Axis	Displays the module where power supply Overvoltage (ov) occurred in binary. <b>Note:</b> This setting is available only in model 4A0630.	No signal output available	–
U4-37 (1044H)	Heatsink Overheat (oH) Module	OH Alarm Axis	Displays the module where Heatsink Overheat (oH) occurred in binary. <b>Note:</b> This setting is available only in model 4A0630.	No signal output available	–
U4-38 (1045H)	Cooling Fan Error (Fan) Module	FAN Alarm Axis	Displays the module where Cooling Fan Error (Fan) occurred in binary. <b>Note:</b> This setting is available only in model 4A0630.	No signal output available	–
<b>U6: Operation Status Monitors</b>					
U6-80 to U6-99 (7B0H to 7F9H)	Option Monitors 1 to 20	–	Shows the monitor information for Option Monitor 1 (876 hex) to 20 (8FF hex). This information is displayed when option cards are connected. 200 V Class: 100% = 400 Vdc 400 V Class: 100% = 800 Vdc	No signal output available	–
<b>U8: Operation Status Monitors</b>					
U9-01 (820H)	Electric Power (GWh)	GWh Consumed	Shows the total amount of electric power.  000 000 000 kWh 	0 to 999	1GWh
U9-02 (821H)	Electric Power (MWh)	MWh Consumed		0 to 999	1MWh
U9-03 (822H)	Electric Power (kWh)	kWh Consumed		0 to 999	1kWh
U9-04 (823H)	Regenerative Power (GWh)	GWh Produced	Shows the total amount of regenerated power.  000 000 000 kWh 	0 to 999	1GWh
U9-05 (824H)	Regenerative Power (MWh)	MWh Produced		0 to 999	1MWh
U9-06 (825H)	Regenerative Power (kWh)	kWh Produced		0 to 999	1kWh



No. (Address Hex)	Name	LCD Display	Description	Analog Output Level	Unit
U9-07 to U9-10 (826H to 829H)	Electric Power Rates 1 to 4	Consumed □ (\$)	<p>These parameters show the electric power rate in Power Unit Price (o4-19) that is calculated from the total electrical power consumptions in U9-01 to U9-03.</p> <p>000 000 000 000</p> <p>The unit price is set in o4-19, and U9-07 to U9-10 are U9-01 to U9-03 times o4-19.</p>	0 to 999	–
U9-11 to U9-14 (82AH to 82DH)	Regenerative Power Rates 1 to 4	Produced □ (\$)	<p>These parameters show the regenerative power rate in Power Unit Price (o4-19) that is calculated from the total electrical power consumptions in U9-04 to U9-06.</p> <p>000 000 000 000</p> <p>The unit price is set in o4-19, and U9-11 to U9-14 are U9-04 to U9-06 times o4-19.</p>	0 to 999	–

<4> The MEMOBUS/Modbus communications data is in 10 h units. If data in 1 h units are also required, refer to register number 0099H.  
 <5> The MEMOBUS/Modbus communications data is in 10 h units. If data in 1 h units are also required, refer to register number 009BH.

## B.3 Defaults by Converter Model

The following tables show parameters and default settings that change with o2-04 (drive model selection).

**Table B.1 200 V Class Model Default Settings by Converter Model Selection**

No.	Name	Unit	Default Settings							
			Model	2A0005	2A0010	2A0020	2A0030	2A0050	2A0065	2A0090
o2-04	Model Selection	Hex	68	6B	6E	70	73	75	76	78
d8-01	DC Bus Voltage Reference	V	330	330	330	330	330	330	330	330
L2-02	Momentary Power Loss Ride-Thru Time	s	1.0	1.0	2.0	2.0	2.0	2.0	2.0	2.0
L2-05	Undervoltage Detection Level (Uv)	V	190	190	190	190	190	190	190	190
L2-21	AUv Detection Level	V	150	150	150	150	150	150	150	150
L8-02	Overheat Alarm Level	°C	110	125	115	125	130	135	135	130
L8-09	Output Ground Fault Detection Selection	–	1	1	1	1	1	1	1	1
L8-66	Power Supply Fault Detection Voltage Level	%	50	50	50	50	50	50	50	50
C7-47	Adjustment Reactor 1	mH	2.450	1.267	0.645	0.443	0.263	0.184	0.136	0.092
C7-51	Adjustment Reactor 2	mH	0.809	0.418	0.213	0.146	0.087	0.061	0.045	0.030
L8-35	Installation Method Selection	–	0	0	0	0	0	0	0	0

**Table B.2 400 V Class Model Default Settings by Converter Model Selection**

No.	Name	Unit	Default Settings											
			Model	4A0005	4A0010	4A0020	4A0030	4A0040	4A0060	4A0100	4A0130	4A0185	4A0270	4A0370
o2-04	Model Selection	Hex	97	9A	9D	9F	A1	A3	A5	A7	A9	AC	AE	B2
d8-01	DC Bus Voltage Reference	V	660	660	660	660	660	660	660	660	660	660	660	660
L2-02	Momentary Power Loss Ride-Thru Time	s	0.5	1.0	2.0	2.0	2.0	2.0	2.0	2.0	2.0	2.0	2.0	2.0
L2-05	Undervoltage Detection Level (Uv)	V	380	380	380	380	380	380	380	380	380	380	380	380
L2-21	AUv Detection Level	V	300	300	300	300	300	300	300	300	300	300	300	300
L8-02	Overheat Alarm Level	°C	110	115	115	115	115	130	140	145	140	130	130	130
L8-09	Output Ground Fault Detection Selection	–	1	1	1	1	1	1	1	1	1	1	1	1
L8-66	Power Supply Fault Detection Voltage Level	%	50	50	50	50	50	50	50	50	50	50	50	50
C7-47	Adjustment Reactor 1	mH	9.189	4.594	2.450	1.710	1.267	0.855	0.507	0.350	0.245	0.179	0.131	0.064
C7-51	Adjustment Reactor 2	mH	3.308	1.654	0.882	0.615	0.456	0.308	0.183	0.126	0.088	0.065	0.047	0.023
L8-35	Installation Method Selection	–	0	0	0	0	0	0	0	0	0	0	0	0

# Appendix: C

## MEMOBUS/Modbus Communications

---

<b>C.1</b>	<b>MEMOBUS/MODBUS CONFIGURATION .....</b>	<b>204</b>
<b>C.2</b>	<b>COMMUNICATION SPECIFICATIONS .....</b>	<b>205</b>
<b>C.3</b>	<b>CONNECTING TO A NETWORK .....</b>	<b>206</b>
<b>C.4</b>	<b>MEMOBUS/MODBUS SETUP PARAMETERS.....</b>	<b>210</b>
<b>C.5</b>	<b>CONVERTER OPERATIONS BY MEMOBUS/MODBUS .....</b>	<b>213</b>
<b>C.6</b>	<b>COMMUNICATIONS TIMING .....</b>	<b>214</b>
<b>C.7</b>	<b>MESSAGE FORMAT .....</b>	<b>215</b>
<b>C.8</b>	<b>MESSAGE EXAMPLES.....</b>	<b>217</b>
<b>C.9</b>	<b>MEMOBUS/MODBUS DATA TABLE .....</b>	<b>219</b>
<b>C.10</b>	<b>ENTER COMMAND .....</b>	<b>229</b>
<b>C.11</b>	<b>COMMUNICATION ERRORS .....</b>	<b>230</b>
<b>C.12</b>	<b>SELF-DIAGNOSTICS .....</b>	<b>231</b>

### C.1 MEMOBUS/Modbus Configuration

Converter can be controlled from a PLC or other master device via serial communications using the MEMOBUS/Modbus protocol.

MEMOBUS/Modbus communications can be configured using one master (PLC) and up to 255 slaves. The converter has slave functionality only, and serial communication is normally initiated from the master and responded to by the slaves.

The master communicates with the specified slave converter. The address or node for each slave must be set prior so the master can communicate with the slave at that address. A slave that receives a command from the master will perform the specified function and send a response back to the master.

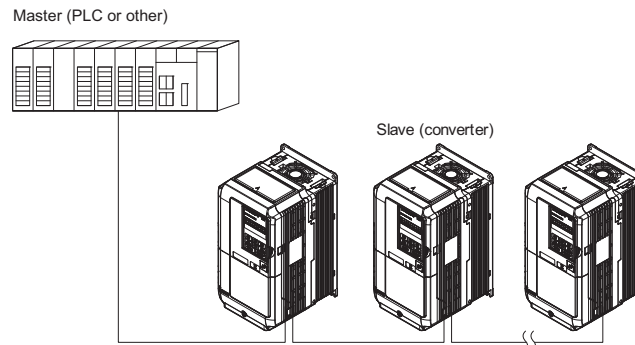

**Figure C.1 Connecting Multiple Converter to a PLC**

## C.2 Communication Specifications

MEMOBUS/Modbus specifications appear in *Table C.1*:

**Table C.1 MEMOBUS/Modbus Communications Specifications**

Item	Specifications	
<b>Interface</b>	RS-422, RS-485	
<b>Communications Cycle</b>	Asynchronous (Start-stop synchronization)	
<b>Communication Parameters</b>	Communication Speeds Available	1.2; 2.4; 4.8; 9.6; 19.2; 38.4; 57.6; 76.8; 115.2 kbps
	Data length	8-bit (fixed)
	Parity	Select even, odd, or none
	Stop bit	1-bit (fixed)
<b>Protocol</b>	MEMOBUS/Modbus (using RTU mode only)	
<b>Max Number of Slaves</b>	31 converters (RS-485)	

### C.3 Connecting to a Network

This section explains how to connect the converter to a MEMOBUS/Modbus network and the network termination required for a connection.

#### ◆ Network Cable Connection

Follow the instructions below to connect the converter to a MEMOBUS/Modbus network.

1. With the power shut off, connect the communications cable to the converter and the master. Use terminals TB5 for MEMOBUS/Modbus.

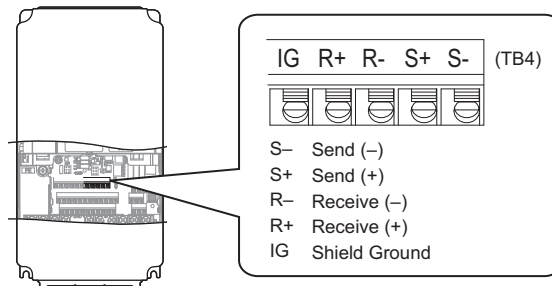

**Figure C.2 Serial Communications Cable Connection Terminals (TB4)**

**Note:** Separate the communications cables from the main circuit cables and other wiring and power cables. Use shielded cables for the communications cables, and properly shielded clamps to prevent problems with electrical noise. When using RS-485 communications, connect S+ to R+, and S- to R- as shown in the diagram below.

2. Check or set the termination resistor selection at all slaves. Use the description in [Network Termination on page 209](#) for slaves that are converters.
3. Switch the power on.
4. Set the parameters needed for serial communications (H5-01 through H5-12) using the digital operator.
5. Shut the power off and wait until the display on the digital operator goes out completely.
6. Turn the power back on.
7. The converter is now ready to begin communicating with the master.

## ◆ Wiring Diagram for Multiple Connections

*Figure C.3* and *Figure C.4* explain the wiring diagrams for multiple connections using MEMOBUS/Modbus communication.

### ■ RS-485 Interface

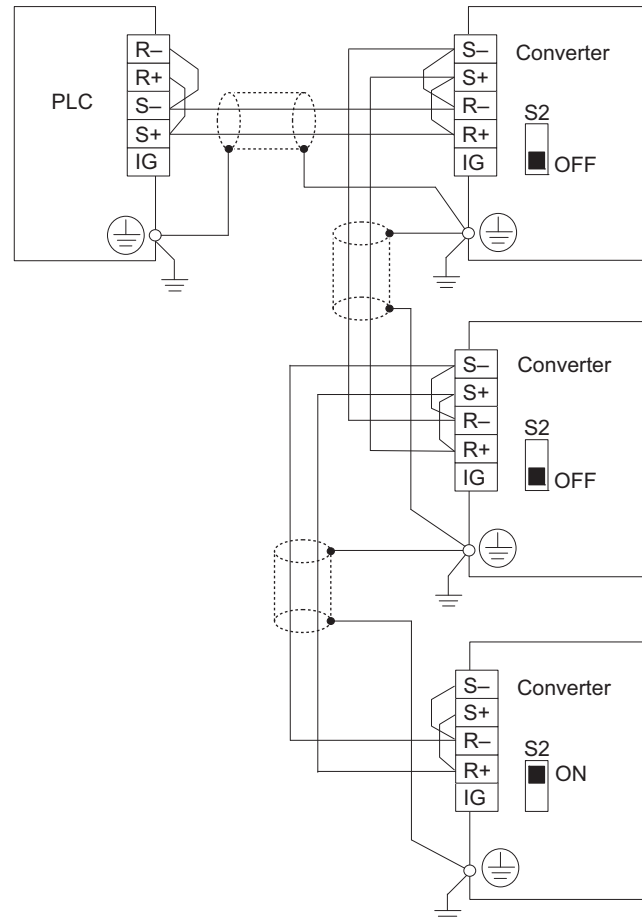

**Figure C.3 RS-485 Interface**

- Note:**
1. Set DIP switch S2 to the ON position on the converter located at the end of the network. Set DIP switch S2 to the OFF positions on all other slave devices.
  2. Set H5-07 to 1 when using the RS-485 interface.

#### ■ RS-422 Interface

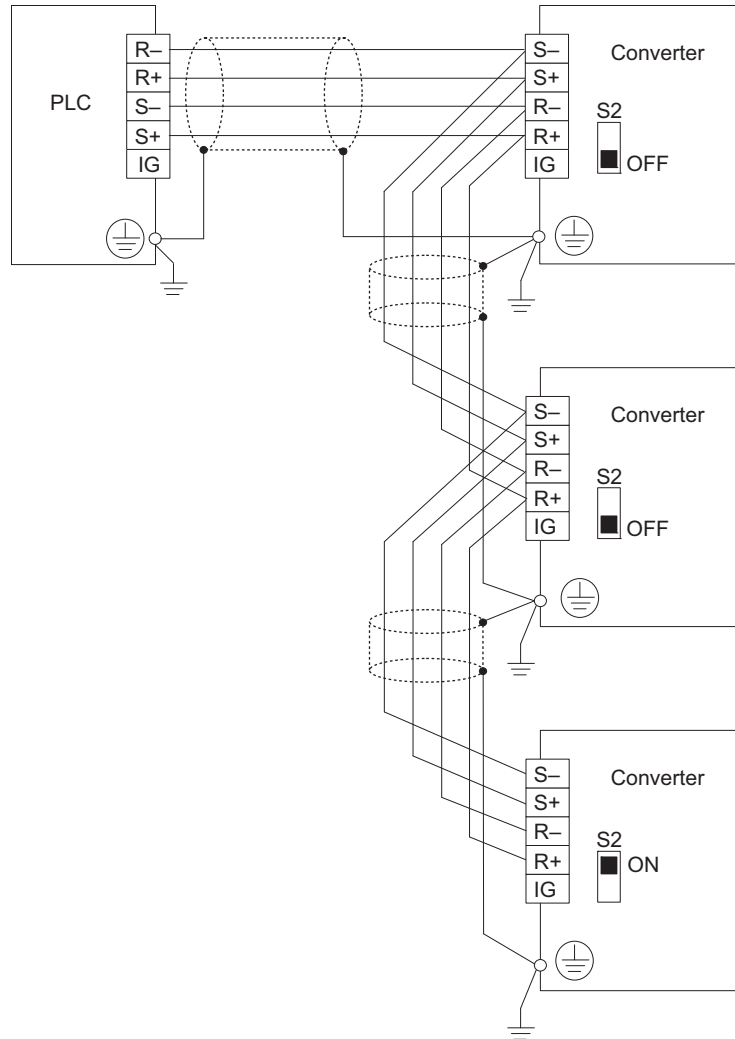

**Figure C.4 RS-422 Interface**

- Note:**
1. Set DIP switch S2 to the ON position on the converter located at the end of the network. Set DIP switch S2 to the OFF positions on all other slave devices.
  2. Set H5-07 to 1 when using the RS-422 interface in a multi-drop circuit.  
Set H5-07 to 0 when using the RS-422 interface in a point-to-point circuit.



## ◆ Network Termination

The two ends of the MEMOBUS/Modbus network line have to be terminated. The converter has a built in termination resistor that can be enabled or disabled using DIP switch S2. If a converter is located at the end of a network line, enable the termination resistor by setting DIP switch S2 to the ON position. Disable the termination resistor on all slaves that are not located at the network line end.

To set the DIP switch, use tweezers or a tool with a tip width of approximately 0.8 mm.

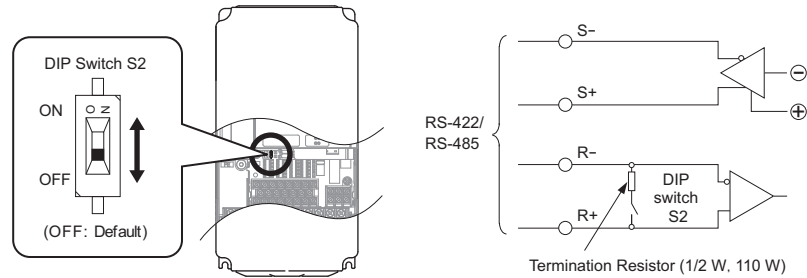

**Figure C.5 Communication Terminals and DIP Switch S2**

## C.4 MEMOBUS/Modbus Setup Parameters

### ◆ MEMOBUS/Modbus Serial Communication

This section describes parameters necessary to set up MEMOBUS/Modbus communications.

#### ■ H5-01: Drive Slave Address

Sets the converter slave address used for communications.

**Note:** Cycle the power after changing this parameter to enable the new setting.

No.	Name	Setting Range	Default
H5-01	Drive Slave Address	0 to FFH <1>	1FH

<1> If the address is set to 0, no response will be provided during communications.

Each slave converter must be assigned a unique slave address for serial communications to work. Setting H5-01 to any value besides 0 assigns the converter its address in the network. Slave addresses do not need to be assigned in sequential order, but no two converters may share the same address.

#### ■ H5-02: Communication Speed Selection

Sets the MEMOBUS/Modbus communications speed.

**Note:** Cycle the power after changing this parameter to enable the new setting.

No.	Name	Setting Range	Default
H5-02	Communication Speed Selection	0 to 5	3

**Setting 0: 1200 bps**

**Setting 1: 2400 bps**

**Setting 2: 4800 bps**

**Setting 3: 9600 bps**

**Setting 4: 19200 bps**

**Setting 5: 38400 bps**

**Setting 6: 57600 bps**

**Setting 7: 76800 bps**

**Setting 8: 115200 bps**

#### ■ H5-03: Communication Parity Selection

Sets the parity used for communications.

**Note:** Cycle the power after changing this parameter to enable the new setting.

No.	Name	Setting Range	Default
H5-03	Communication Parity Selection	0 to 2	0

**Setting 0: No parity**

**Setting 1: Even parity**

**Setting 2: Odd parity**

■ **H5-04: Stopping Method after Communication Error**

Selects the stopping method after a communications error (CE) has occurred.

No.	Name	Setting Range	Default
H5-04	Stopping Method after CE	1, 3	3

**Setting 1: Stop operation**

**Setting 3: Alarm only (continue operation)**

■ **H5-05: Communication Fault Detection Selection**

Enables or disables the CE detection for communications.

No.	Name	Setting Range	Default
H5-05	Communication Fault Detection Selection	0 or 1	1

**Setting 0: Disabled**

No communication error detection. The converter continues operation.

**Setting 1: Enabled**

If the converter does not receive data from the master for longer than the time set to H5-09, then a CE fault will be triggered and the converter will operate as determined by parameter H5-04.

■ **H5-06: Drive Transmit Wait Time**

Sets the time the converter waits after receiving data from a master until responding data.

No.	Name	Setting Range	Default
H5-06	Drive Transmit Wait Time	5 to 65 ms	5 ms

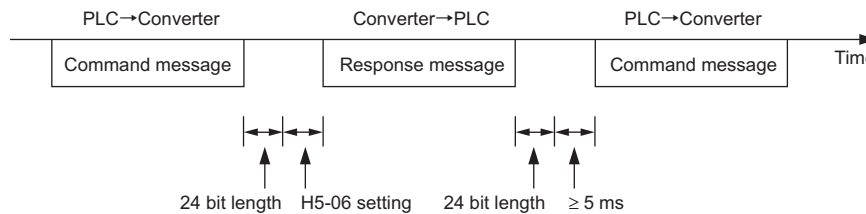

Figure C.6 Converter Transmit Wait Time Setting

■ **H5-07: RTS Control Selection**

Enables or disables RTS control.

No.	Name	Setting Range	Default
H5-07	RTS Control Selection	0 or 1	1

**Setting 0: Disabled. RTS is always on.**

Use this setting with point-to-point or multi-drop RS-422 communications.

**Setting 1: Enabled. RTS switches while sending.**

Use this setting when using RS-485 signals for communications or when using the RS-422 signals for point-to-point communications.

■ **H5-09: Communications Fault Detection Time**

Sets the time the communications must be lost before the converter triggers a CE fault.

No.	Name	Setting Range	Default
H5-09	Communications Fault Detection Time	0.0 to 10.0 s	2.0 s

## C.4 MEMOBUS/Modbus Setup Parameters

---

### ■ H5-11: Communications Enter Function Selection

Selects whether an Enter command is necessary to change parameter values via MEMOBUS/Modbus communications. Refer to *Enter Command on page 229*.

No.	Name	Setting Range	Default
H5-11	Communications Enter Function Selection	0 or 1	1

#### Setting 0: Enter command necessary

Parameter changes become effective after an Enter command. An Enter command must only be sent after the last parameter change, not for each single parameter.

#### Setting 1: Enter command not necessary

Parameter value changes become effective immediately without the need to send an Enter command.

## C.5 Converter Operations by MEMOBUS/Modbus

The converter operations that can be performed by MEMOBUS/Modbus communication depend on converter parameter settings. This section explains the functions that can be used and related parameter settings.

### ◆ Observing the Converter Operation

A PLC can perform the following actions with MEMOBUS/Modbus communications at any time regardless of parameter settings (except for H5-□□ parameters):

- observe converter status and converter control terminal status from a PLC.
- read and write parameters.
- set and reset faults.
- set multi-function inputs.

**Note:** Input settings from the input terminals (S1 to S8) and from MEMOBUS/Modbus communications are both linked by a logical OR operation.

### ◆ Controlling the Converter

Select an external reference and adjust the parameters in [Table C.2](#) accordingly to start and stop the converter or set the voltage reference using MEMOBUS/Modbus communications.

**Table C.2 Setting Parameters for Converter Control from MEMOBUS/Modbus**

Reference Source	Parameter	Name	Required Setting
External Reference 1	b1-02	Run Command Selection 1	2
	b1-18	Voltage Reference Source	2

Refer to [Voltage Reference Source on page 182](#) and [b1-02 \(181H\) on page 182](#) for details.

## C.6 Communications Timing

To prevent a communications overrun in the slave converter, the master should wait a certain time between sending messages to the same converter. In the same way, the slave converter must wait before sending response messages to prevent an overrun in the master. This section explains the message timing.

### ◆ Command Messages from Master to Converter

The master must wait for a specified time between receiving a response and resending the same type of command to the same slave converter to prevent overrun and data loss. The minimum wait time depends on the command as shown in *Table C.3*.

**Table C.3 Minimum Wait Time for Sending Messages**

Command Type	Example	Minimum Wait Time
1	<ul style="list-style-type: none"> <li>Control command (Run, Stop)</li> <li>Set inputs/outputs</li> <li>Read monitors and parameter values</li> </ul>	5 ms <I>
2	Write parameters	H5-11 = 0: 50 ms H5-11 = 1: 200 ms <I>
3	Save changes using an Enter command	200 ms to 2 s, depending on the number of parameters that were changed <I>

<I> If the converter receives command type 1 data during the minimum wait time, it will perform the command and then respond. However, if it receives a command type 2 or 3 during that time, either a communication error will result or the command will be ignored.

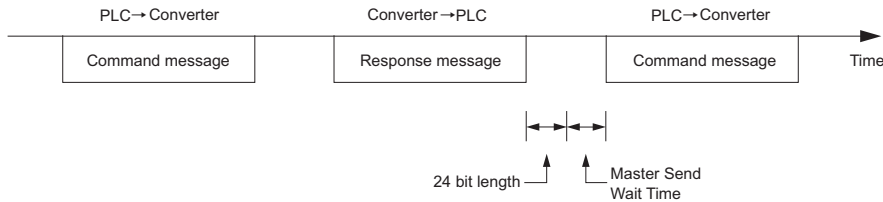
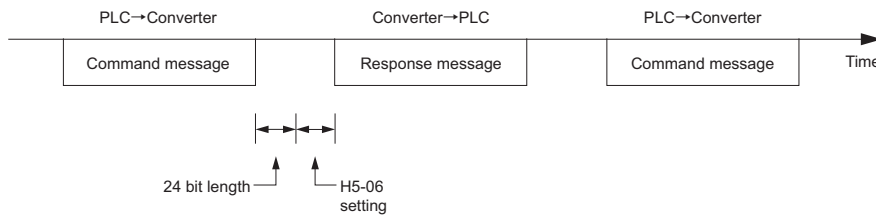

**Figure C.7 Minimum Wait Time for Sending Messages**

Set a timer in the master to check how long it takes for the slave converter (s) to respond to the master. If no response is received within a certain amount of time, the master should try resending the message.

### ◆ Response Messages from Converter to Master

If the slave converter receives a command from the master, it will process the data received and wait for the time set in H5-06 until it responds. Increase H5-06 if the converter response causes overrun in the master.



**Figure C.8 Minimum Response Wait Time**

## C.7 Message Format

### ◆ Message Content

In MEMOBUS/Modbus communications, the master sends commands to the slave, and the slave responds. The message format is configured for both sending and receiving as shown below, and the length of data packets depends on the command (function) content.

SLAVE ADDRESS
FUNCTION CODE
DATA
ERROR CHECK

### ◆ Slave Address

The slave address in the message defines the note the message is sent to. Use addresses between 0 and FF (hex). If a message with slave address 0 is sent (broadcast), the command from the master will be received by all slaves. The slaves do not provide a response to a broadcast type message.

### ◆ Function Code

The three types of function codes are shown in the table below.

Function Code	Function Name	Data Length (bytes)			
		Command Message		Response Message	
		Minimum	Maximum	Minimum	Maximum
03H	Read MEMOBUS/Modbus registers	8	8	7	37
08H	Loopback test	8	8	8	8
10H	Write to multiple MEMOBUS/Modbus registers	11	41	8	8

### ◆ Data

Configure consecutive data by combining the MEMOBUS/Modbus register address (test code in case of a loopback test) and the data the register contains. The data length changes depending on the command details.

A converter MEMOBUS/Modbus register always has a data length of two bytes. Data written into converter registers must also always have a length of two bytes. Register data read out from the converter will always consist of two bytes.

### ◆ Error Check

The converter uses a CRC-16 (cyclic redundancy check, checksum method) for checking data validity. Use the procedure described below when calculating the CRC-16 checksum for command data or when verifying response data.

#### ■ Command Data

When the converter receives data, it calculates the CRC-16 checksum from the data and compares it to the CRC-16 value received within the message. Both must match before a command is processed.

An initial value of FFFFH (i.e., all 16 bits equal 1) must be used for CRC-16 calculations in the MEMOBUS/Modbus protocol.

## C.7 Message Format

Calculate the CRC-16 checksum using the following steps:

1. The starting value is FFFFH.
2. Perform an XOR operation of this value and the slave address.
3. Right shift the result.
4. When the overflow bit of the shift operation becomes 1, perform an XOR operation of the result from step 3 above and the fix value A001H.
5. Repeat steps 3 and 4 until eight shift operations have been performed.
6. After eight shift operations, perform an XOR operation with the result and the next data in the message (function code, register address, data). Continue with steps 3 to 5 until the last data has been processed.
7. The result of the last shift or XOR operation is the checksum.

The example in [Table C.4](#) shows the CRC-16 calculation of the slave address 02H and the function code 03H, yielding the result D140H.

**Note:** This example does not show the calculation for a complete MEMOBUS/Modbus command. Normally data would follow in the calculation.

**Table C.4 CRC-16 Checksum Calculation Example**

Description	Calculation	Overflow	Description	Calculation	Overflow
Initial Value (FFFFH)	1111 1111 1111 1111		Function Code 03H	0000 0011	
Address 02H	0000 0010		XOR w result	1000 0001 0011 1101	
XOR w initial value	1111 1111 1111 1101		Shift 1	0100 0000 1001 1110	1
Shift 1	0111 1111 1111 1110	1	XOR w A001H	1010 0000 0000 0001	
XOR w A001H	1010 0000 0000 0001		XOR result	1110 0000 1001 1111	
XOR result	1101 1111 1111 1111		Shift 2	0111 0000 0100 1111	1
Shift 2	0110 1111 1111 1111	1	XOR w A001H	1010 0000 0000 0001	
XOR w A001H	1010 0000 0000 0001		XOR result	1101 0000 0100 1110	
XOR result	1100 1111 1111 1110		Shift 3	0110 1000 0010 0111	0
Shift 3	0110 0111 1111 1111	0	Shift 4	0011 0100 0001 0011	1
Shift 4	0011 0011 1111 1111	1	XOR w A001H	1010 0000 0000 0001	
XOR w A001H	1010 0000 0000 0001		XOR result	1001 0100 0001 0010	
XOR result	1001 0011 1111 1110		Shift 5	0100 1010 0000 1001	0
Shift 5	0100 1001 1111 1111	0	Shift 6	0010 0101 0000 0100	1
Shift 6	0010 0100 1111 1111	1	XOR w A001H	1010 0000 0000 0001	
XOR w A001H	1010 0000 0000 0001		XOR result	1000 0101 0000 0101	
XOR result	1000 0100 1111 1110		Shift 7	0100 0010 1000 0010	1
Shift 7	0100 0010 0111 1111	0	XOR w A001H	1010 0000 0000 0001	
Shift 8	0010 0001 0011 1111	1	XOR result	1110 0010 1000 0011	
XOR w A001H	1010 0000 0000 0001		Shift 8	0111 0001 0100 0001	1
XOR result	1000 0001 0011 1110		XOR w A001H	1010 0000 0000 0001	
			XOR result	1101 0001 0100 0000	
				1101 0001 0100 0000	
Perform operations with next data (function code)			CRC-16	D 1 4 0	
				Lower Upper	
			Continue from here with next data.		

### ■ Response Data

Perform a CRC-16 calculation on the response message data as described above as a validation check. The result should match the CRC-16 checksum received within the response message.



## C.8 Message Examples

Below are some examples of command and response messages.

### ◆ Reading Converter MEMOBUS/Modbus Register Contents

Using the function code 03H (Read), a maximum of 16 MEMOBUS/Modbus registers can be read out at a time.

The following table shows message examples when reading error details and data link status from the slave 2 converters.

Command Message			Response Message (normal)		
Slave Address		02H	Slave Address		02H
Function Code		03H	Function Code		03H
Starting No.	Upper	00H	Data Quantity		04H
	Lower	21H	1st storage register	Upper	00H
Data Quantity	Upper	00H		Lower	00H
	Lower	02H	Next storage register	Upper	00H
CRC-16	Upper	94H		Lower	00H
	Lower	32H	CRC-16	Upper	C9H
				Lower	33H

### ◆ Loopback Test

Function code 08H performs a loopback test that returns a response message with exactly the same content as the command message. The response message can be used to check communications between the master and slave. User-defined test code and data values can also be set.

The following table shows a message example when performing a loopback test with the slave 1 converter.

Command Message			Response Message (normal)			Response Message (fault)		
Slave Address		01H	Slave Address		01H	Slave Address		01H
Function Code		08H	Function Code		08H	Function Code		88H
Test Code	Upper	00H	Test Code	Upper	00H	Error Code		01H
	Lower	00H		Lower	00H	CRC-16	Upper	86H
Data	Upper	A5H	Data	Upper	A5H		Lower	50H
	Lower	37H		Lower	37H			
CRC-16	Upper	DAH	CRC-16	Upper	DAH			
	Lower	8DH		Lower	8DH			

## C.8 Message Examples

### ◆ Writing to Multiple Registers

Function code 10H allows the user to write multiple converter MEMOBUS/Modbus registers with one message. This process works similar to reading registers, in that the address of the first register to be written and the data quantity are set in the command message. The data to be written must be consecutive so that the register addresses are in order, starting from the specified address in the command message. The data order must be high byte then lower byte.

The following table shows an example of a message where 2000H has been set with a Multi-Function Analog Output 1 and 4000H has been set with a Multi-Function Analog Output 2 for the slave 1 converter.

If parameter values are changed using the Write command, an Enter command may be necessary to activate or save the data depending on the setting of H5-11. Refer to *H5-11: Communications Enter Function Selection on page 212* and Refer to *Enter Command on page 229* for detailed descriptions.

Command Message			Response Message (normal)		
Slave Address		01H	Slave Address		01H
Function Code		10H	Function Code		10H
Starting No.	Upper	00H	Starting No.	Upper	00H
	Lower	07H		Lower	07H
Data Quantity	Upper	00H	Data Quantity	Upper	00H
	Lower	02H		Lower	02H
Number of Bytes		04H	CRC-16	Upper	F0H
Starting Data	Upper	20H		Lower	09H
	Next Data	Upper	40H		
CRC-16		Upper	88H		
	Lower	49H			

**Note:** Double the number of the data quantity for the number of bytes in the command message.

## C.9 MEMOBUS/Modbus Data Table

The table below lists all MEMOBUS/Modbus data. There are three types of data: command data, monitor data, and broadcast data.

### ◆ Command Data

It is possible to both read and write command data.

**Note:** Bits that are not used should be set to 0. Refrain from writing to reserved registers.

Register No.	Contents	
0000H	Reserved	
0001H	Operation Commands and Multi-function Inputs	
	bit 0	Forward/Stop 1: Forward 0: Stop
	bit 1	Reserved
	bit 2	External Fault (EF0)
	bit 3	Fault Reset
	bit 4	Multi-Function Input 1
	bit 5	Multi-Function Input 2
	bit 6	Multi-Function Input 3
	bit 7	Multi-Function Input 4
	bit 8	Multi-Function Input 5
	bit 9	Multi-Function Input 6
	bit A	Multi-Function Input 7
	bit B	Multi-Function Input 8
	bit C - bit F	Reserved
0002H - 0003H	Reserved	
0004H	Active Current Limit (Positive) 100.0%/1000	
0005H - 0006H	Reserved	
0007H	Analog Output Terminal FM Setting (10 V / 4000 H)	
0008H	Analog Output Terminal AM Setting (10 V / 4000 H)	
0009H	Settings for Multi-Function Relay Outputs	
	bit 0	Multi-Function Relay Output 1 (terminal M1-M2)
	bit 1	Multi-Function Relay Output 1 (terminal M3-M4)
	bit 2	Multi-Function Relay Output 2 (terminal M5-M6)
	bit 3 - bit 5	Reserved
	bit 6	Enables the function in bit 7
	bit 7	Fault Contact Output (terminal MA/MB-MC)
bit 8 - bit F	Reserved	
000AH - 000CH	Reserved	
000DH	DC Bus Voltage Reference 1V/1	
000EH	Active Current Limit (Negative) 100.0%/1000	
000FH - 001AH	Reserved	
001BH	Analog Monitor Option AO-A3 Analog Output 1 (10 V/4000 H)	
001CH	Analog Monitor Option AO-A3 Analog Output 2 (10 V/4000 H)	
001DH	Digital Output Option DO-A3 Output (Binary)	
001EH - 001FH	Reserved	

## C.9 MEMOBUS/Modbus Data Table

### ◆ Monitor Data

Monitor data can be read only.

Register No.	Contents	
0020H	Converter Status 1	
	bit 0	During Run
	bit 1	Reserved
	bit 2	Operation Ready
	bit 3	Fault
	bit 4	Data Setting Error
	bit 5	Multi-Function Relay Output (terminal M1-M2)
	bit 6	Multi-Function Relay Output 1 (terminal M3-M4)
	bit 7	Multi-Function Relay Output 2 (terminal M5-M6)
bit 8 - bit F	Reserved	
0021H	Fault Contents 1	
	bit 0	Overcurrent (oC), Ground fault (GF)
	bit 1	Overvoltage (ov)
	bit 2	Converter Overload (oL2)
	bit 3	Overheat 1 (oH1), Overheat 2 (oH2)
	bit 4 - bit 6	Reserved
	bit 7	EF to EF8: External Fault
	bit 8	CPF□□: Hardware Fault (includes oF□)
	bit 9 - bit A	Reserved
	bit B	Main Circuit Undervoltage (Uv)
	bit C	Undervoltage (Uv1), Control Power Supply Undervoltage (Uv2), Soft Charge Circuit Fault (Uv3)
	bit D	Output Phase Loss (LF), Input Phase Loss (PF)
	bit E	MEMOBUS/Modbus Communication Error (CE), Option Communication Error (bUS)
bit F	Operator Connection Fault (oPr)	
0022H	Data Link Status	
	bit 0	Writing data or switching motors
	bit 1 - bit 2	Reserved
	bit 3	Upper or lower limit error
	bit 4	Data conformity error
	bit 5	Writing to EEPROM
bit 6 - bit F	Reserved	
0023H - 0028H	Reserved	
0029H	Fault Contents 2	
	bit 0	Reserved
	bit 1	Ground Fault (GF)
	bit 2 - bit F	Reserved

Register No.	Contents	
002AH	Alarm Contents 1	
	bit 0 - bit 2	Reserved
	bit 3	Drive Baseblock (bb)
	bit 4	Reserved
	bit 5	Heatsink Overheat (oH)
	bit 6	Overvoltage (ov)
	bit 7	Undervoltage (Uv)
	bit 8	Cooling Fan Error (Fan)
	bit 9	MEMOBUS/Modbus Communication Error (CE)
	bit A	Option Communication Error (bUS)
	bit B - bit E	Reserved
bit F	Serial Communication Transmission Error (CALL)	
002BH	Input Terminal Status	
	bit 0	Terminal S1 Closed
	bit 1	Terminal S2 Closed
	bit 2	Terminal S3 Closed
	bit 3	Terminal S4 Closed
	bit 4	Terminal S5 Closed
	bit 5	Terminal S6 Closed
	bit 6	Terminal S7 Closed
	bit 7	Terminal S8 Closed
bit 8 - bit F	Reserved	
002CH	Drive Status 2	
	bit 0	During Run
	bit 1 - bit 5	Reserved
	bit 6	Drive Ready
	bit 7	During Undervoltage
	bit 8	During Baseblock
	bit 9	Voltage Reference from Operator Keypad
	bit A	Run Command from Operator Keypad
	bit B - bit C	Reserved
	bit D	During Fault Restart
	bit E	Fault
bit F	Communication Timeout	
002DH	Output Terminal Status	
	bit 0	Multi-Function Relay Output 1 (terminal M1-M2)
	bit 1	Multi-Function Relay Output 1 (terminal M3-M4)
	bit 2	Multi-Function Relay Output 2 (terminal M5-M6)
	bit 3 - bit 6	Reserved
	bit 7	Fault Contact Output (terminal MA/MB-MC)
bit 8 - bit F	Reserved	

## C.9 MEMOBUS/Modbus Data Table

Register No.	Contents	
002EH	Converter Status	
	bit 0	1: During Run 0: During Stop
	bit 2	1: During Regenerative Operation
	bit 3	1: During Reset Signal Input
	bit 4	1: During run (Operation Ready)
	bit 5	1: Operation Ready
	bit 6	1: Alarm
	bit 7	1: Fault
	bit 8	1: oPE Error
	bit 9	1: Momentary Power Loss Ridethru 0: Recovery from Momentary Power Loss
	bit A	1: ComCtrl status/NetCtrl status
	bit D	1: During Active Current Limit
002FH - 0033H	Reserved	
0034H	Product Code 1 [ASCII], Product Type (D1000 = DA)	
0035H	Product Code 2 [ASCII], Region Code	
0036H - 003CH	Reserved	
003DH	Communications Error Contents <f>	
	bit 0	CRC Error
	bit 1	Data Length Error
	bit 2	Reserved
	bit 3	Parity Error
	bit 4	Overflow Error
	bit 5	Framing Error
	bit 6	Timeout
	bit 7 to bit F	Reserved
003EH - 003FH	Reserved	
0040H - 004AH	Used for various monitors U1-□□. Refer to <i>U: Monitors on page 195</i> for parameter details.	
004BH	Converter status (U1-12)	
	bit 0	During Run
	bit 1 - bit 2	Reserved
	bit 3	During Fault Reset Signal Input
	bit 4	Not Used
	bit 5	Operation Ready
	bit 6	Alarm
	bit 7	Fault
	bit 8 - bit B	Reserved
	bit E	ComRef status, NetRef status
bit F	ComCtrl status, NetCtrl status	
004CH - 007EH	Used for various monitors U1-□□, U4-□□, U5-□□ and U6-□□. Refer to <i>U2: Fault Trace on page 197</i> and <i>U3: Fault History on page 199</i> for parameter details.	
007FH	Alarm Code, Refer to <i>Alarm Register Contents on page 228</i> for alarm codes.	
0080H - 0097H	Used for monitors U2-□□, U3-□□. Refer to <i>U: Monitors on page 195</i> for parameter details and Refer to <i>Fault Trace Contents on page 227</i> for register value descriptions.	
0098H	High Word of Accumulated Operation Time Monitor, 10 h units (U4-01)	
0099H	Low Word of Accumulated Operation Time Monitor, 1 h units (U4-01)	
009AH	High Word of Cooling Fan Operation Time Monitor (U4-03)	
009BH	Low Word of Cooling Fan Operation Time Monitor (U4-03)	
009CH - 00AAH	Reserved	
00ABH	Converter Rated Current	
00ACH - 00AFH	Reserved	

Register No.	Contents		
00B0H	Option Code Connected to CN5-A	Register contains ASCII code of the option card. DO-A3 = 0002H AI-A3 = 0003H AO-A3 = 0004H Communication Option: Register contains ASCII code of first and third digit of the option card type number. Example: Register value is 5343H for “SC” if an SI-C3 option card is installed.	
00B1H	Reserved		
00B2H	Option Code Connected to CN5-B		
00B3H	Option Code Connected to CN5-C		
00B4H - 00BEH	Reserved		
00BFH	Lists the last two digits of operation error code oPE□□.		
00C0H	Fault Contents 3		
	bit 0	DC Fuse Blowout (PUF)	
	bit 1	Undervoltage (Uv1)	
	bit 2	Control Power Supply Undervoltage (Uv2)	
	bit 3	Soft Charge Circuit Fault (Uv3)	
	bit 4	IGBT Short Circuit (SC)	
	bit 5	Ground Fault (GF)	
	bit 6	Overcurrent (oC)	
	bit 7	Overvoltage (ov)	
	bit 8	Heatsink Overheat (oH)	
	bit 9	Overheat 1 (oH1)	
	bit A	Reserved	
	bit B	Converter Overload (oL2)	
bit C - bit F	Reserved		
00C1H	Fault Contents 4		
	bit 0	External Fault at input terminal S3 (EF3)	
	bit 1	External Fault at input terminal S4 (EF4)	
	bit 2	External Fault at input terminal S5 (EF5)	
	bit 3	External Fault at input terminal S6 (EF6)	
	bit 4	External Fault at input terminal S7 (EF7)	
	bit 5	External Fault at input terminal S8 (EF8)	
	bit 6	Cooling Fan Error (Fan)	
	bit 7 - bit C	Reserved	
	bit D	Digital Operator Connection Fault (oPr)	
	bit E	EEPROM Write Error (Err)	
bit F	Reserved		
00C2H	Fault Contents 5		
	bit 0	MEMOBUS/Modbus Communication Error (CE)	
	bit 1	Option Communication Error (bUS)	
	bit 2 - bit 5	Reserved	
	bit 6	Option External Fault (EF0)	
	bit 7 - bit E	Reserved	
	bit F	Hardware Fault (includes oF□)	
00C3H	Fault Contents 6		
	bit 0 - bit 7	Reserved	
	bit 8	MECHATROLINK Watchdog Timer Error (E5)	
	bit 9 - bit F	Reserved	

## C.9 MEMOBUS/Modbus Data Table

Register No.	Contents	
00C4H	Fault Contents 7	
	bit 0	Reserved
	bit 1	External Fault 1, input terminal S1 (EF1)
	bit 2	External Fault 2, input terminal S2 (EF2)
	bit 3 - bit 4	Reserved
	bit 5	Current Offset Fault (CoF)
00C5H	Fault Contents 8	
	bit 0	Reserved
	bit 1	Node Setup Fault (nSE)
00C6H	Fault Contents 9	
	bit 0	Power Supply Module Undervoltage (Uv4)
	bit 1 - bit 4	Reserved
	bit 5	Power Supply Undervoltage (AUv)
	bit 6	Power Supply Overvoltage (Aov)
	bit 7	Power Supply Frequency Fault (Fdv)
	bit 8	Power Phase Rotation Variation (SrC)
	bit 9	Input Power Supply Fault (PF2)
	bit A	Input Phase Loss 3 (PF3)
	bit B - E	Reserved
bit F	AC Fuse Blowout (FUA)	
00C7H	Reserved	
00C8H	Alarm Contents 2	
	bit 0	Undervoltage (Uv)
	bit 1	Overvoltage (ov)
	bit 2	Heatsink Overheat (oH)
	bit 3	Overheat 2 (oH2)
	bit 4 - bit 6	Reserved
	bit 7	Drive Baseblock (bb)
	bit 8	External Fault 3, input terminal S3 (EF3)
	bit 9	External Fault 4, input terminal S4 (EF4)
	bit A	External Fault 5, input terminal S5 (EF5)
	bit B	External Fault 6, input terminal S6 (EF6)
	bit C	External Fault 7, input terminal S7 (EF7)
	bit D	External Fault 8, input terminal S8 (EF8)
bit E	Cooling Fan Error (Fan)	
bit F	Reserved	



Register No.	Contents	
00C9H	Alarm Contents 3	
	bit 0 - bit 1	Reserved
	bit 2	Digital Operator Connection Fault (oPr)
	bit 3	MEMOBUS/Modbus Communication Error (CE)
	bit 4	Option Communication Error (bUS)
	bit 5	Serial Communication Transmission Error (CALL)
	bit 6	Reserved
	bit 7	Converter Overload (oL2)
	bit 8	Reserved
	bit 9	Option Card External fault (EF0)
	bit A - bit B	Reserved
	bit C	Serial Communication Transmission Error (CALL)
	bit D - bit E	Reserved
bit F	MEMOBUS/Modbus Test Mode Fault (SE)	
00CAH	Reserved	
00CBH	Alarm Contents 5	
	bit 0	MECHATROLINK Watchdog Timer Error (E5)
	bit 1	MECHATROLINK Station Address Setting Error (AEr)
	bit 2	MECHATROLINK Communication Cycle Setting Error (CyC)
	bit 3	High Current Alarm (HCA)
	bit 4	Cooling Fan Maintenance Time (LT-1)
	bit 5	Soft Charge Bypass Relay Maintenance Time (LT-2)
	bit 6	Reserved
	bit 7	SI-S EEPROM Error (EEP)
	bit 8	External Fault 1 (input terminal S1) (EF1)
	bit 9	External Fault 2 (input terminal S2) (EF2)
bit A - bit F	Reserved	
00CCH	Alarm Contents 6	
	bit 0 - bit 1	Reserved
	bit 2	Capacitor Maintenance Time (LT-3)
	bit 3 - bit E	Reserved
	bit F	Power Supply Undervoltage (AUv)
00CDH - 00CFH	Reserved	
00D0H	CPF Contents 1	
	bit 0, 1	Reserved
	bit 2	A/D Conversion Error (CPF02)
	bit 3	PWM Data Fault (CPF03)
	bit 4, 5	Reserved
	bit 6	EEPROM Memory Data Error (CPF06)
	bit 7	Terminal Board Connection Error (CPF07)
	bit 8	EEPROM Serial Communications Fault (CPF08)
	bit 9, A	Reserved
	bit B	RAM Fault (CPF11)
	bit C	FLASH Memory Fault (CPF12)
	bit D	Watchdog Circuit Exception (CPF13)
	bit E	Control Circuit Fault (CPF14)
bit F	Reserved	

## C.9 MEMOBUS/Modbus Data Table

Register No.	Contents	
00D1H	CPF Contents 2	
	bit 0	Clock Fault (CPF16)
	bit 1	Timing Fault (CPF17)
	bit 2	Control Circuit Fault (CPF18)
	bit 3	Control Circuit Fault (CPF19)
	bit 4	Hardware fault at power up (CPF20)
	bit 5	Hardware fault at communication start up (CPF21)
	bit 6	A/D Conversion Fault (CPF22)
	bit 7	PWM Feedback Fault (CPF23)
	bit 8	Unit Capacity Detect Fault (CPF24)
	bit 9	Terminal board is not properly connected. (CPF25)
	bit A	ASIC BB Circuit Error (CPF26)
	bit B	ASIC PWM Setting Register Error (CPF27)
	bit C	ASIC PWM Pattern Error (CPF28)
	bit D	ASIC On-delay Error (CPF29)
	00D2H	bit E
bit F		ASIC Code Error (CPF31)
bit 0		ASIC Start-up Error (CPF32)
bit 1		Watch-dog Error (CPF33)
bit 2		ASIC Power/Clock Error (CPF34)
bit 3		External A/D Converter Error (CPF35)
bit 4 - 7		Reserved
bit 8		Control Circuit Error (CPF40)
bit 9		Control Circuit Error (CPF41)
bit A		Control Circuit Error (CPF42)
bit B		Control Circuit Error (CPF43)
bit C	Control Circuit Error (CPF44)	
bit D	Control Circuit Error (CPF45)	
bit E, F	Reserved	
00D3H - 00D7H	Reserved	
00D8H	oFA0□ Contents (CN5-A)	
	bit 0	Option Compatibility Error (oFA00)
	bit 1	Option not properly connected (oFA01)
	bit 2	Same type of option card already connected (oFA02)
	bit 3, 4	Reserved
	bit 5	A/D Conversion Error (oFA05)
	bit 6	Option Response Error (oFA06)
	bit 7 - F	Reserved
00D9H	oFA1□ Contents (CN5-A)	
	bit 0	Option RAM Fault (oFA10)
	bit 1	Option Operation Mode Fault (SLMOD) (oFA11)
	bit 2	Converter Receive CRC Error (oFA12)
	bit 3	Converter Receive Frame Error (oFA13)
	bit 4	Converter Receive Abort Error (oFA14)
	bit 5	Option Receive CRC Error (oFA15)
	bit 6	Option Receive Frame Error (oFA16)
	bit 7	Option Receive Abort Error (oFA17)
	bit 8 - F	Reserved
00DAH - 00DBH	Reserved	

Register No.	Contents	
00DBH	oFA3□ Contents (CN5-A)	
	bit 0	Communication ID Error (oFA30)
	bit 1	Model Code Error (oFA31)
	bit 2	Sumcheck Error (oFA32)
	bit 3	Communication option timeout waiting for response (oFA33)
	bit 4	MEMOBUS/Modbus Timeout (oFA34)
	bit 5	Converter timeout waiting for response (oFA35)
	bit 6	CI Check Error (oFA36)
	bit 7	Converter timeout waiting for response (oFA37)
	bit 8	Control Command Selection Error (oFA38)
	bit 9	Converter timeout waiting for response (oFA39)
	bit A	Control Response Selection 1 Error (oFA40)
	bit B	Converter timeout waiting for response (oFA41)
	bit C	Control Response Selection 2 Error (oFA42)
	bit D	Control Response Selection Error (oFA43)
bit E, F	Reserved	
00DCH - 00FBH	Reserved	

<1> Communication error contents are saved until the fault is reset.

### ◆ Fault Trace Contents

The table below shows the fault codes that can be read out by MEMOBUS/Modbus commands from the U2-□□ monitor parameters.

**Table C.5 Fault Trace / History Register Contents**

Fault Code	Fault Name	Fault Code	Fault Name
0001H	DC Fuse Blowout (FUd)	0097H	A/D Conversion Fault (CPF22)
0002H	Undervoltage (Uv1)	0098H	PWM Feedback Fault (CPF23)
0003H	Control Power Supply Undervoltage (Uv2)	0099H	Unit Capacity Detect Fault (CPF24)
0004H	Soft Charge Circuit Fault (Uv3)	009AH	Terminal Board is Not Properly Connected. (CPF25)
0005H	IGBT Short Circuit (SC)	009BH	ASIC BB Circuit Error (CPF26)
0006H	Ground Fault (GF)	009CH	ASIC PWM Setting Register Error (CPF27)
0007H	Overcurrent (oC)	009DH	ASIC PWM Pattern Error (CPF28)
0008H	Overvoltage (ov)	009EH	ASIC On-delay Error (CPF29)
0009H	Heatsink Overheat (oH)	009FH	ASIC BBON Error (CPF30)
000AH	Overheat 1 (oH1)	00A0H	ASIC Code Error (CPF31)
000CH	Converter Overload (oL2)	00A1H	ASIC Start-up Error (CPF32)
0011H	External Fault at Input Terminal S3 (EF3)	00A2H	Watch-dog Error (CPF33)
0012H	External Fault at Input Terminal S4 (EF4)	00A3H	ASIC Power/Clock Error (CPF34)
0013H	External Fault at Input Terminal S5 (EF5)	00A4H	External A/D Converter Error (CPF35)
0014H	External Fault at Input Terminal S6 (EF6)	00A9H	Control Circuit Error (CPF40)
0015H	External Fault at Input Terminal S7 (EF7)	00AAH	Control Circuit Error (CPF41)
0016H	External Fault at Input Terminal S8 (EF8)	00ABH	Control Circuit Error (CPF42)
001EH	Digital Operator Connection (oPr)	00ACH	Control Circuit Error (CPF43)
001FH	EEPROM Write Error (Err)	00ADH	Control Circuit Error (CPF44)
0021H	MEMOBUS/Modbus Communication Error (CE)	00AEH	Control Circuit Error (CPF45)
0022H	Option Communication Error (bUS)	0101H	Option Compatibility Error (oFA00)
0027H	Option External Fault (EF0)	0102H	Option Not Properly Connected (oFA01)
0030H	Hardware Fault (including oF□)	0103H	Same Type of Option Card Already Connected (oFA02)
0042H	External Fault 1, Input Terminal S1 (EF1)	0106H	A/D Conversion Error (oFA05)

## C.9 MEMOBUS/Modbus Data Table

Fault Code	Fault Name	Fault Code	Fault Name
0043H	External Fault 2, Input Terminal S2 (EF2)	0107H	Option Response Error (oFA06)
0046H	Current Offset Fault (CoF)	0111H	Option RAM Fault (oFA10)
0047H	PLC Detection Error 1 (PE1)	0112H	Option Operation Mode Fault (SLMOD) (oFA11)
0048H	PLC Detection Error 2 (PE2)	0113H	Converter Receive CRC Error (oFA12)
0052H	Node Setup Fault (nSE)	0114H	Converter Receive Frame Error (oFA13)
0061H	Power Supply Module Undervoltage (Uv4)	0115H	Converter Receive Abort Error (oFA14)
0006B	Power Supply Undervoltage Pre-alarm	0116H	Option Receive CRC Error (oFA15)
0070H	AC Fuse Blowout (FUA)	0117H	Option Receive Frame Error (oFA16)
0071H	Power Supply Resonance Detection (vrE)	0118H	Option Receive Abort Error (oFA17)
0083H	A/D Conversion Error (CPF02)	0131H	Communication ID Error (oFA30)
0084H	PWM Data Fault (CPF03)	0132H	Model Code Error (oFA31)
0087H	EEPROM Memory Data Error (CPF06)	0133H	Sumcheck Error (oFA32)
0088H	Terminal Board Connection Error (CPF07)	0134H	Communication Option Timeout Waiting for Response (oFA33)
0089H	EEPROM Serial Communication Fault (CPF08)	0135H	MEMOBUS/Modbus Timeout (oFA34)
008CH	RAM Fault (CPF11)	0136H	Converter Timeout Waiting for Response (oFA35)
008DH	Flash Memory Circuit Exception (CPF12)	0137H	CI Check Error (oFA36)
008EH	Watchdog Circuit Exception (CPF13)	0138H	Converter Timeout Waiting for Response (oFA37)
008FH	Control Circuit Fault (CPF14)	0139H	Control Command Selection Error (oFA38)
0091H	Clock Fault (CPF16)	013AH	Converter Timeout Waiting for Response (oFA39)
0092H	Timing Fault (CPF17)	013BH	Control Response Selection 1 Error (oFA40)
0093H	Control Circuit Fault (CPF18)	013CH	Converter Timeout Waiting for Response (oFA41)
0094H	Control Circuit Fault (CPF19)	013DH	Control Response Selection 2 Error (oFA42)
0095H	Hardware Fault at Power Up (CPF20)	013EH	Control Response Selection Error (oFA43)
0096H	Hardware Fault at Communication Start Up (CPF21)	–	–

### ◆ Alarm Register Contents

The table below shows the alarm codes that can be read out from MEMOBUS/Modbus register 007FH.

**Table C.6 Alarm Register 007FH Contents**

Fault Code	Fault Name	Fault Code	Fault Name
0001H	Undervoltage (Uv)	0020H	MEMOBUS/Modbus Test Mode Fault (SE)
0002H	Overvoltage (ov)	0031H	MECHATROLINK Watchdog Timer Error (E5)
0003H	Heatsink Overheat (oH)	0032H	MECHATROLINK Station Address Setting Error (AEr)
0008H	Converter Baseblock (bb)	0033H	MECHATROLINK Communication Cycle Setting Error (CyC)
0009H	External Fault 3, input terminal S3 (EF3)	0034H	High Current Alarm (HCA)
000AH	External Fault 4, input terminal S4 (EF4)	0035H	Cooling Fan Maintenance Time (LT-1)
000BH	External Fault 5, input terminal S5 (EF5)	0036H	Capacitor Maintenance Time (LT-2)
000CH	External Fault 6, input terminal S6 (EF6)	0038H	SI-S EEPROM Error (EEP)
000DH	External Fault 7, input terminal S7 (EF7)	0039H	External Fault (input terminal S1) (EF1)
000EH	External Fault 8, input terminal S8 (EF8)	003AH	External Fault (input terminal S2) (EF2)
000FH	Cooling Fan Error (Fan)	003FH	PLC Alarm 1 (PA1)
0014H	MEMOBUS/Modbus Communication Error (CE)	0040H	PLC Alarm 2 (PA2)
0015H	Option Communication Error (bUS)	0043H	Soft Charge Bypass Relay Maintenance Time (LT-3)
0018H	Converter Overload (oL2)	006AH	Power Supply Resonance Detection (vrE)
001AH	Option Card External Fault (EF0)	006BH	Power Supply Undervoltage Pre-Alarm (PAUv)
001DH	Serial Communication Transmission Error (CALL)	–	–

## C.10 Enter Command

When writing parameters to the converter from the PLC using MEMOBUS/Modbus communication, parameter H5-11 determines whether an Enter command must be issued to enable these parameters. This section describes the types and functions of the Enter commands.

### ◆ Enter Command Types

The converter supports two types of Enter commands as shown in *Table C.7*. An Enter command is enabled by writing 0 to register numbers 0900H or 0910H. It is only possible to write to these registers; attempting to read from these registers will cause an error.

**Table C.7 Enter Command Types**

Register No.	Description
0900H	Simultaneously writes data into the EEPROM (non-volatile memory) of the converter and enables the data in RAM. Parameter changes remain after cycling power.
0910H	Writes data in the RAM only. Parameter changes are lost when the converter is shut off.

**Note:** The EEPROM can only be written to 100,000 times, so it is recommended to limit the number of times writing to the EEPROM. The Enter command registers are write-only and if these registers are read, the register address will be invalid (Error code: 02H). An Enter command is not required when reference or broadcast data are sent to the converter.

## C.11 Communication Errors

### ◆ MEMOBUS/Modbus Error Codes

A list of MEMOBUS/Modbus errors appears below.

When an error occurs, remove whatever caused the error and restart communications.

Error Code	Error Name
	Cause
01H	Function Code Error
	Attempted to set a function code from a PLC other than 03H, 08H, and 10H.
02H	Register Number Error
	<ul style="list-style-type: none"> <li>• A register number specified in the command message does not exist.</li> <li>• Attempted to send a broadcast message using other register numbers than 0001H or 0002H.</li> </ul>
03H	Bit Count Error
	<ul style="list-style-type: none"> <li>• Read data or write data is greater than 16 bits. Invalid command message quantity.</li> <li>• In a write message, the “Number of Data Items” contained within the message does not equal twice the amount of data words (i.e., the total of Data 1+ Data 2, etc.).</li> </ul>
21H	Data Setting Error
	<ul style="list-style-type: none"> <li>• Control data or parameter write data is outside the allowable setting range.</li> <li>• Attempted to write a contradictory parameter setting.</li> </ul>
22H	Write Mode Error
	<ul style="list-style-type: none"> <li>• During run, the user attempted to write a parameter that cannot be written to during run.</li> <li>• During an EEPROM memory data error (CPF06), the master attempted to write to a parameter other than A1-00 to A1-05, E1-03, or o2-04.</li> <li>• Attempted to write to read-only data.</li> </ul>
23H	DC Bus Undervoltage Write Error
	During an undervoltage situation, the master attempted to write to parameters that cannot be written to during undervoltage.
24H	Write Error During Parameter Process
	Master attempted writing to the converter while the converter was processing parameter data.

### ◆ Slave Not Responding

In the following situations, the slave converter will ignore the command message sent from the master, and not send a response message:

- When a communications error (overrun, framing, parity, or CRC-16) is detected in the command message.
- When the slave address in the command message and the slave address in the converter do not match (remember to set the slave address for the converter using H5-01).
- When the gap between two blocks (8-bit) of a message exceeds 24 bits.
- When the command message data length is invalid.

**Note:** If the slave address specified in the command message is 00H, all slaves execute the write function, but do not return response messages to the master.

## C.12 Self-Diagnostics

The converter has a built-in self-diagnosing function of the serial communication interface circuits. To perform the self-diagnosis function, use the following procedure.

**DANGER! Electrical Shock Hazard.** Do not connect or disconnect wiring while the power is on. Failure to comply will result in death or serious injury. Before servicing, disconnect all power to the equipment. The internal capacitor remains charged even after the power supply is turned off. The charge indicator LED will extinguish when the DC bus voltage is below 50 Vdc. To prevent electric shock, wait at least one minute after all indicators are OFF and measure the DC bus voltage level to confirm safe level.

1. Turn on the power to the converter.
2. Note the present terminal S6 function selection setting (H1-06) and set it for the communications test mode (H1-06 = 67).
3. Turn off the power to the converter.
4. With the power off, wire the converter as shown in **Figure C.9**, connecting terminals R+ and S+, R- and S-, and S6 and SC.

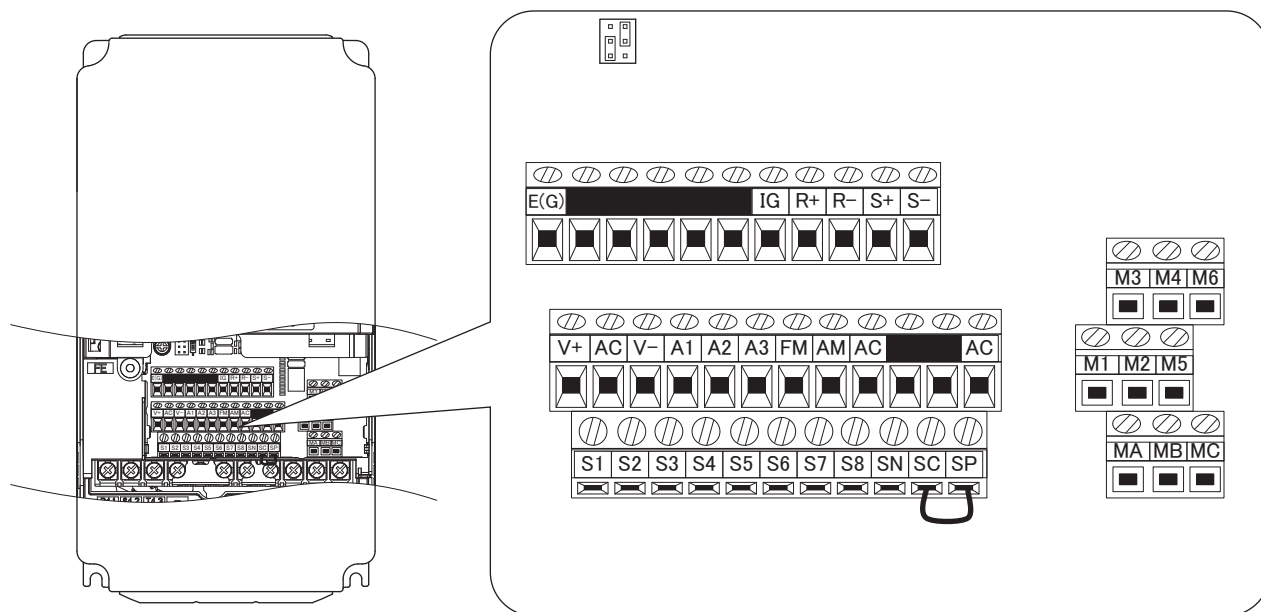

**Figure C.9 Terminal Connections for Communication Self-Diagnostics**

5. Set jumper S3 to source mode (internal power supply).
6. Turn the power to the converter back on.
7. During normal operation, the converter will display "Pass" to indicate that the communications test mode is operating normally.  
When a fault occurs, the converter will display "CE" on the keypad display.
8. Turn off the power supply.
9. Remove the wire jumpers from terminal R+, R-, S+, S-, and S6-SC. Reset jumper S3 to its original position and set terminal S6 to its original function.
10. Return to normal operation.





# Appendix: D

## Standards Compliance

---

This appendix explains the guidelines and criteria for maintaining CE and UL standards.

<b>D.1</b>	<b>SECTION SAFETY</b> .....	<b>234</b>
<b>D.2</b>	<b>EUROPEAN STANDARDS</b> .....	<b>236</b>
<b>D.3</b>	<b>UL STANDARDS</b> .....	<b>247</b>
<b>D.4</b>	<b>CSA STANDARDS COMPLIANCE</b> .....	<b>257</b>

## D.1 Section Safety

### WARNING

#### Electrical Shock Hazard

**Do not operate equipment with covers removed.**

Failure to comply could result in death or serious injury.

The diagrams in this section may show converters without covers or safety shields to show details. Be sure to reinstall covers or shields before operating the converters and run the converters according to the instructions described in this manual.

**Do not connect or disconnect wiring while the power is on.**

Failure to comply will result in death or serious injury.

**Always ground the motor-side grounding terminal.**

Improper equipment grounding could result in death or serious injury by contacting the motor case.

**Do not touch any terminals before the capacitors have fully discharged.**

Failure to comply could result in death or serious injury.

Before wiring terminals, disconnect all power to the equipment. The internal capacitor remains charged even after the power supply is turned off. After shutting off the power, wait for at least the amount of time specified on the converter before touching any components.

**Do not allow unqualified personnel to perform work on the converter.**

Failure to comply could result in death or serious injury.

Installation, maintenance, inspection, and servicing must be performed only by authorized personnel familiar with installation, adjustment, and maintenance of AC converters.

**Do not perform work on the converter while wearing loose clothing, jewelry, or lack of eye protection.**

Failure to comply could result in death or serious injury.

Remove all metal objects such as watches and rings, secure loose clothing, and wear eye protection before beginning work on the converter.

**Do not remove covers or touch circuit boards while the power is on.**

Failure to comply could result in death or serious injury.

#### Fire Hazard

**Tighten all terminal screws to the specified tightening torque.**

Loose electrical connections could result in death or serious injury by fire due to overheating of electrical connections.

**Do not use an improper voltage source.**

Failure to comply could result in death or serious injury by fire.

Verify that the rated voltage of the converter matches the voltage of the incoming power supply before applying power.

**Do not use improper combustible materials.**

Failure to comply could result in death or serious injury by fire.

Attach the converter to metal or other noncombustible material.

**NOTICE****Observe proper electrostatic discharge procedures (ESD) when handling the converter and circuit boards.**

Failure to comply may result in ESD damage to the converter circuitry.

**Never connect or disconnect the motor from the converter while the converter is outputting voltage.**

Improper equipment sequencing could result in damage to the converter.

**Do not use unshielded cable for control wiring.**

Failure to comply may cause electrical interference resulting in poor system performance. Use shielded twisted-pair wires and ground the shield to the ground terminal of the converter.

**Do not allow unqualified personnel to use the product.**

Failure to comply could result in damage to the converter.

**Do not modify the converter circuitry.**

Failure to comply could result in damage to the converter and will void warranty.

Yaskawa is not responsible for any modification of the product made by the user. This product must not be modified.

**Check all the wiring to ensure that all connections are correct after installing the converter and connecting any other devices.**

Failure to comply could result in damage to the converter.

**If a fuse is open or a Ground Fault Circuit Interrupter (GFCI) is tripped, check the wiring and the selection of the peripheral devices.**

Contact your supplier if the cause cannot be identified after checking the above.

**Do not restart the converter immediately operate the peripheral devices if a fuse is open or a GFCI is tripped.**

Check the wiring and the selection of peripheral devices to identify the cause. Contact your supplier before restarting the converter or the peripheral devices if the cause cannot be identified.

## D.2 European Standards



Figure D.1 CE Mark

The CE mark indicates compliance with European safety and environmental regulations. It is required for engaging in business and commerce in Europe.

European standards include the Machinery Directive for machine manufacturers, the Low Voltage Directive for electronics manufacturers, and the EMC guidelines for controlling electrical noise.

This converter displays the CE mark based on the EMC guidelines and the Low Voltage Directive.

- Low Voltage Directive: 2006/95/EC
- EMC Guidelines: 2004/108/EC

Devices used in combination with this converter must also be CE certified and display the CE mark. When using converter displaying the CE mark in combination with other devices, it is ultimately the responsibility of the user to ensure compliance with CE standards. After setting up the device, verify that conditions meet European standards.

### ◆ CE Low Voltage Directive Compliance

This converter has been tested according to European standard IEC/EN 61800-5-1, and it fully complies with the Low Voltage Directive.

To comply with the Low Voltage Directive, be sure to meet the following conditions when combining this converter with other devices:

#### ■ Area of Use

Do not use converter in areas with pollution higher than severity 2 and overvoltage category 3 in accordance with IEC664.

#### ■ Standard Configuration Devices

Install appropriate input fuses built into the input side of the harmonic filter module to protect converter wiring and prevent other secondary damage. Select harmonic filter module according to [Table D.1](#) to [Table D.3](#).

Refer to [Power Ratings on page 174](#) for details on the converter Input Current and Rated Output Current.

**NOTICE:** If a fuse is open or a Ground Fault Circuit Interrupter (GFCI) is tripped, check the wiring and the selection of peripheral devices to identify the cause. Contact Yaskawa before restarting the converter or the peripheral devices if the cause cannot be identified.

Table D.1 Recommended Standard Configuration Devices

Model	Harmonic Filter Module	Input Fuse			Three Phase Input AC Reactor		Three Phase Input Film Capacitor	
		Model	Manufacturer	Fuse Rating Ampere (A)	SAO ELECTRIC CORP.		Nichicon Corp.	
					Model	Ratings	Model	Ratings
<b>200 V Class</b>								
2A0005	EUJ71080□	350GH-25ULTC	HINODE	25	300-052-260	15 A, 0.81 mH, 264 V	EM161050S0UA1HN	160 VAC, 5 uF
2A0010	EUJ71081□	350GH-50ULTC	HINODE	50	300-052-261	29 A, 0.42 mH, 264 V	EM161090S0UA1HN	160 VAC, 9 uF
2A0020	EUJ71082□	350GH-125ULTC	HINODE	125	300-052-262	57 A, 0.21 mH, 264 V	EM161180S0UA1HS	160 VAC, 18 uF

Model	Harmonic Filter Module	Input Fuse			Three Phase Input AC Reactor		Three Phase Input Film Capacitor	
		Model	Manufacturer	Fuse Rating Ampere (A)	SAO ELECTRIC CORP.		Nichicon Corp.	
					Model	Ratings	Model	Ratings
2A0030	EUJ71083□	170M1369	BUSSMANN	160	300-052-263	83 A, 0.15 mH, 264 V	EM161370S1UA1HZ	160 VAC, 12.5 uF
2A0050	EUJ71084□	350GH-250ULTC	HINODE	250	300-052-264	140 A, 0.09 mH, 264 V	EM161281S1UA1HZ	160 VAC, 96 uF
2A0065	EUJ71085□	170M4012	BUSSMANN	400	300-052-265	200 A, 0.06 mH, 264 V	EM161421S1UA1HZ	160 VAC, 140 uF
2A0090	EUJ71086□	170M4013	BUSSMANN	450	300-052-266	270 A, 0.04 mH, 264 V	EM161551S1UA1HZ	160 VAC, 185 uF
2A0130	EUJ71087□	170M4017	BUSSMANN	700	300-052-267	400 A, 0.03 mH, 264 V	EM161421S1UA1HZ	160 VAC, 140 uF
<b>400 V Class</b>								
4A0005	EUJ71088□	660GH-16ULTC	HINODE	16	300-052-268	8 A, 3.31 mH, 528 V	EM3211R2S0UA1HP	320 VAC, 1.2 uF
4A0010	EUJ71089□	660GH-40ULTC	HINODE	40	300-052-269	16 A, 1.65 mH, 528 V	EM3217R5S1UA1HZ	320 VAC, 2.5 uF
4A0020	EUJ71090□	660GH-63ULTC	HINODE	63	300-052-270	30 A, 0.88 mH, 528 V	EM3217R5S1UA1HZ	320 VAC, 2.5 uF
4A0030	EUJ71091□	170M1368	BUSSMANN	125	300-052-271	43 A, 0.62 mH, 528 V	EM321090S1UA1HZ	320 VAC, 3 uF
4A0040	EUJ71092□	170M1369	BUSSMANN	160	300-052-272	58 A, 0.46 mH, 528 V	EM321270S1UA1HZ	320 VAC, 9 uF
4A0060	EUJ71093□	660GH-160ULTC	HINODE	160	300-052-273	86 A, 0.31 mH, 528 V	EM321390S1UA1HZ	320 VAC, 13 uF
4A0100	EUJ71094□	660GH-250ULTC	HINODE	250	300-052-274	145 A, 0.18 mH, 528 V	EM321151S1UA2HZ	320 VAC, 50 uF
4A0130	EUJ71095□	170M4012	BUSSMANN	400	300-052-275	210 A, 0.13 mH, 528 V	EM321101S1UA1HZ	320 VAC, 35 uF
4A0185	EUJ71096□	170M4015	BUSSMANN	550	300-052-276	300 A, 0.09 mH, 528 V	EM321151S1UA2HZ	320 VAC, 50 uF
4A0270	–	170M6011	BUSSMANN	700	300-052-252	410 A, 0.06 mH, 528 V	EF521291TYQ0976	528 VAC, 290 uF
4A0370	–	170M6014	BUSSMANN	1000	300-052-253	560 A, 0.05 mH, 528 V	EF521401TYQ0969	528 VAC, 402 uF
4A0630	–	170M6014	BUSSMANN	1000	300-052-254	1140 A, 0.02 mH, 528 V	EF521801TYQ0984	528 VAC, 800 uF

Table D.2 Three Phase Input AC Reactor 1

Model	SAO ELECTRIC CORP.	
	Model	Ratings
<b>200 V Class</b>		
2A0005	300-052-233	15 A, 2.45 mH, 264 V
2A0010	300-052-234	29 A, 1.27 mH, 264 V
2A0020	300-052-235	57 A, 0.64 mH, 264 V
2A0030	300-052-236	83 A, 0.44 mH, 264 V
2A0050	300-052-237	140 A, 0.26 mH, 264 V
2A0065	300-052-238	200 A, 0.18 mH, 264 V
2A0090	300-052-239	270 A, 0.14 mH, 264 V
2A0130	300-052-240	400 A, 0.09 mH, 264 V
<b>400 V Class</b>		
4A0005	300-052-241	8 A, 9.19 mH, 528 V
4A0010	300-052-242	16 A, 4.59 mH, 528 V
4A0020	300-052-243	30 A, 2.45 mH, 528 V

## D.2 European Standards

Model	SAO ELECTRIC CORP.	
	Model	Ratings
4A0030	300-052-244	43 A, 1.71 mH, 528 V
4A0040	300-052-245	58 A, 1.27 mH, 528 V
4A0060	300-052-246	86 A, 0.85 mH, 528 V
4A0100	300-052-247	145 A, 0.51 mH, 528 V
4A0130	300-052-248	210 A, 0.35 mH, 528 V
4A0185	300-052-249	300 A, 0.25 mH, 528 V
4A0270	300-052-250	410 A, 0.18 mH, 528 V
4A0370	300-052-251	560 A, 0.13 mH, 528 V
4A0630	300-052-251 (×2)	560 A, 0.13 mH, 528 V

Table D.3 Three Phase Input Reactor for Harmonics Filter

Model	SAO ELECTRIC CORP.	
	Model	Ratings
<b>400 V Class</b>		
4A0270	300-052-255	64 A, 0.0218 mH, 528 V
4A0370	300-052-256	87 A, 0.0158 mH, 528 V
4A0630	300-052-257	177 A, 0.0079 mH, 528 V

### ■ Grounding

The converter is designed to be used in T-N (grounded neutral point) networks. If installing the converter in other types of grounded systems, contact your Yaskawa representative for instructions.

### ■ Guarding Against Harmful Materials

When installing IP00/Open Type enclosure converters and standard configuration devices, use an enclosure that prevents foreign material from entering the converter and devices from above or below.

### ◆ EMC Guidelines Compliance

This converter is tested according to European standards IEC/EN 61800-3: 2004, and complies with the European standards IEC/EN 12015 (requires an optional AC reactor) and IEC/EN 12016.

### ■ EMC Filter Installation

The EMC filter must be installed using this installation method to ensure compliance with EMC guidelines. Refer to [EMC Filters on page 239](#) for EMC filter selection.

#### Installation Method

Verify the following installation conditions to ensure that other devices and machinery used in combination with this converter also comply with EMC guidelines.

1. Install an EMC noise filter to the input side specified by Yaskawa for compliance with European standards.
2. Place the converter and EMC noise filter in the same enclosure.
3. Use braided shield cable for the converter and motor wiring, or run the wiring through a metal conduit.
4. Keep wiring as short as possible. Ground the shield on both the converter side and the motor side.
5. Make sure the protective earthing conductor complies with technical standards and local safety regulations.

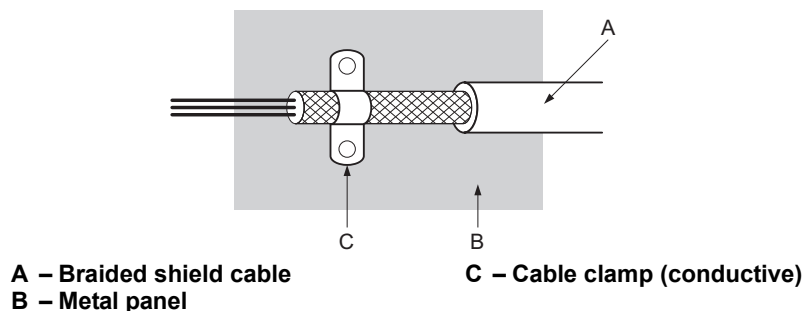

Figure D.2 Ground Area

Connection Diagram

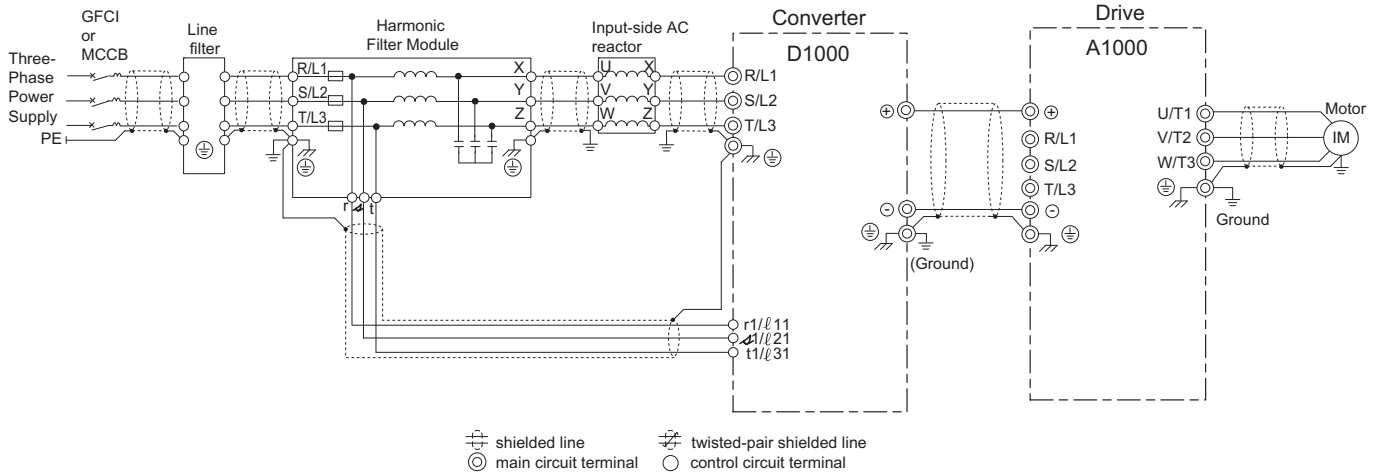

Figure D.3 Wiring Diagram for EMC (Models 2A0005 to 2A0130, 4A0005 to 4A0185)

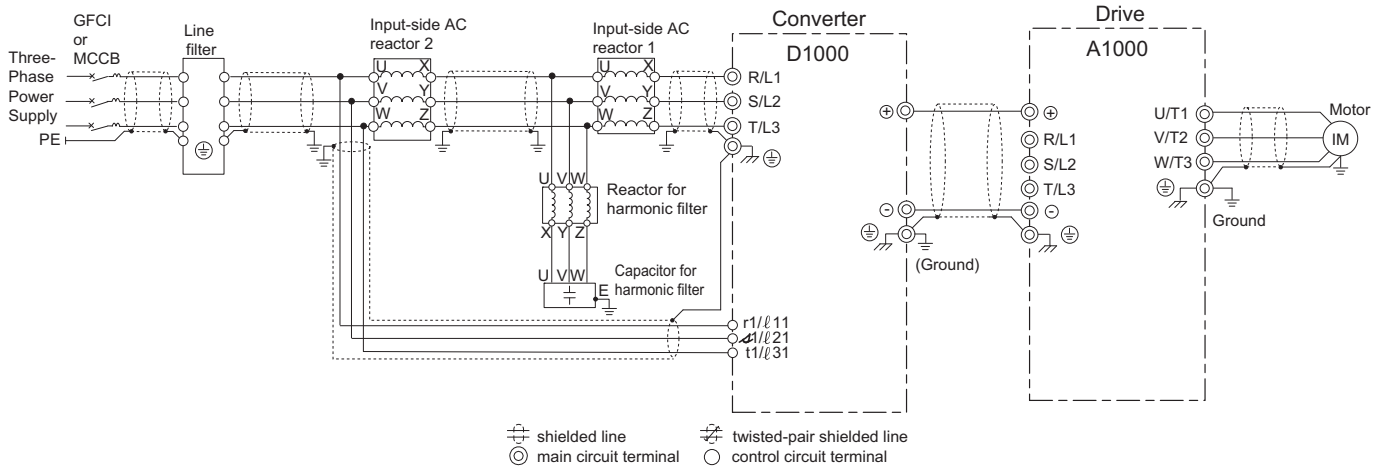

Figure D.4 Wiring Diagram for EMC (Models 4A0270, 4A0370)

■ EMC Filters

The converter should be installed with the EMC filters listed in [Table D.4](#) in order to comply with the IEC/EN 61800-3 requirements.

Table D.4 IEC/EN 61800-3 Filters

Model	Type	Manufacturer	Rated Current (A)	Weight (kg (lb))	Dimensions [W × H × D] mm (in)	Y × X mm (in)	Figure
<b>200 V Class</b>							
2A0005	RTEN-2030C6E3-00	TDK-Lambda	30	1.1 (1.2)	170 × 54 × 90 (5.7 × 1.7 × 2.8)	80 × 160 (2.4 × 5.1)	Figure D.5
2A0010	RTEN-2030C6E3-00	TDK-Lambda	30	1.1 (1.2)	170 × 54 × 90 (5.7 × 1.7 × 2.8)	80 × 160 (2.4 × 5.1)	Figure D.5
2A0020	RTEN-2080G6E2-00	TDK-Lambda	80	3.9 (8.6)	267 × 85 × 161 (10.5 × 3.3 × 6.3)	135 × 247 (5.3 × 9.7)	Figure D.6
2A0030	RTEN-2100G6E3-00	TDK-Lambda	100	5.1 (9.3)	285 × 79 × 152 (10.5 × 3.3 × 6.3)	126 × 265 (5.3 × 9.7)	Figure D.7
2A0050	RTEN-2150G6E2-00	TDK-Lambda	150	6.5 (14.3)	290 × 88 × 190 (11.4 × 3.5 × 7.5)	164 × 270 (6.5 × 10.6)	Figure D.8
2A0065	B84143B0320T176	EPCOS	320	20.7 (55)	605 × 140 × 220 (23.8 × 5.5 × 8.6)	200 × 450 (7.9 × 17.7)	Figure D.9

## D.2 European Standards

Model	Type	Manufacturer	Rated Current (A)	Weight kg (lb)	Dimensions [W × H × D] mm (in)	Y × X mm (in)	Figure
2A0090	B84143B0320T176	EPCOS	320	20.7 (55)	605 × 140 × 220 (23.8 × 5.5 × 8.6)	200 × 450 (7.9 × 17.7)	<i>Figure D.9</i>
2A0130	B84143B0400T176	EPCOS	400	20.9 (55)	605 × 140 × 220 (23.8 × 5.5 × 8.6)	200 × 450 (7.9 × 17.7)	<i>Figure D.9</i>
<b>400 V Class</b>							
4A0005	B84143A0020R106	EPCOS	20	0.6 (1.3)	150 × 58 × 57.5 (5.9 × 2.3 × 2.3)	28 × 132.5 (1.1 × 5.2)	<i>Figure D.10</i>
4A0010	B84143A0020R106	EPCOS	20	0.6 (1.3)	150 × 58 × 57.5 (5.9 × 2.3 × 2.3)	28 × 132.5 (1.1 × 5.2)	<i>Figure D.10</i>
4A0020	B84143A0035R106	EPCOS	35	0.9 (2)	200 × 71 × 72.5 (7.9 × 2.8 × 2.8)	50 × 142.5 (2 × 5.6)	<i>Figure D.11</i>
4A0030	B84143A0065R106	EPCOS	65	1.9 (4.2)	217 × 80 × 84.5 (8.5 × 3.1 × 3.3)	65 × 152.5 (2.6 × 6)	<i>Figure D.12</i>
4A0040	B84143A0065R106	EPCOS	65	1.9 (4.2)	217 × 80 × 84.5 (8.5 × 3.1 × 3.3)	65 × 152.5 (2.6 × 6)	<i>Figure D.12</i>
4A0060	B84143B0180S080	EPCOS	180	5 (11)	270 × 114 × 170 (10.6 × 4.5 × 6.7)	155 × 145 (6.1 × 5.7)	<i>Figure D.13</i>
4A0100	B84143B0180S080	EPCOS	180	5 (11)	270 × 114 × 170 (10.6 × 4.5 × 6.7)	155 × 145 (6.1 × 5.7)	<i>Figure D.13</i>
4A0130	B84143B0400S080	EPCOS	400	7.5 (16.5)	320 × 120 × 190 (12.6 × 4.7 × 7.5)	165 × 170 (6.5 × 6.7)	<i>Figure D.14</i>
4A0185	B84143B0400S080	EPCOS	400	7.5 (16.5)	320 × 120 × 190 (12.6 × 4.7 × 7.5)	165 × 170 (6.5 × 6.7)	<i>Figure D.14</i>
4A0270	B84143B1000S080	EPCOS	1000	18.5 (41)	410 × 140 × 260 (16.1 × 5.5 × 10.2)	235 × 240 (9.3 × 9.4)	<i>Figure D.15</i>
4A0370	B84143B1000S080	EPCOS	1000	18.5 (41)	410 × 140 × 260 (16.1 × 5.5 × 10.2)	235 × 240 (9.3 × 9.4)	<i>Figure D.15</i>
4A0630	B84143B1600S080	EPCOS	1600	24.5 (54)	490 × 140 × 260 (19.3 × 5.5 × 10.2)	235 × 240 (9.3 × 9.4)	<i>Figure D.16</i>



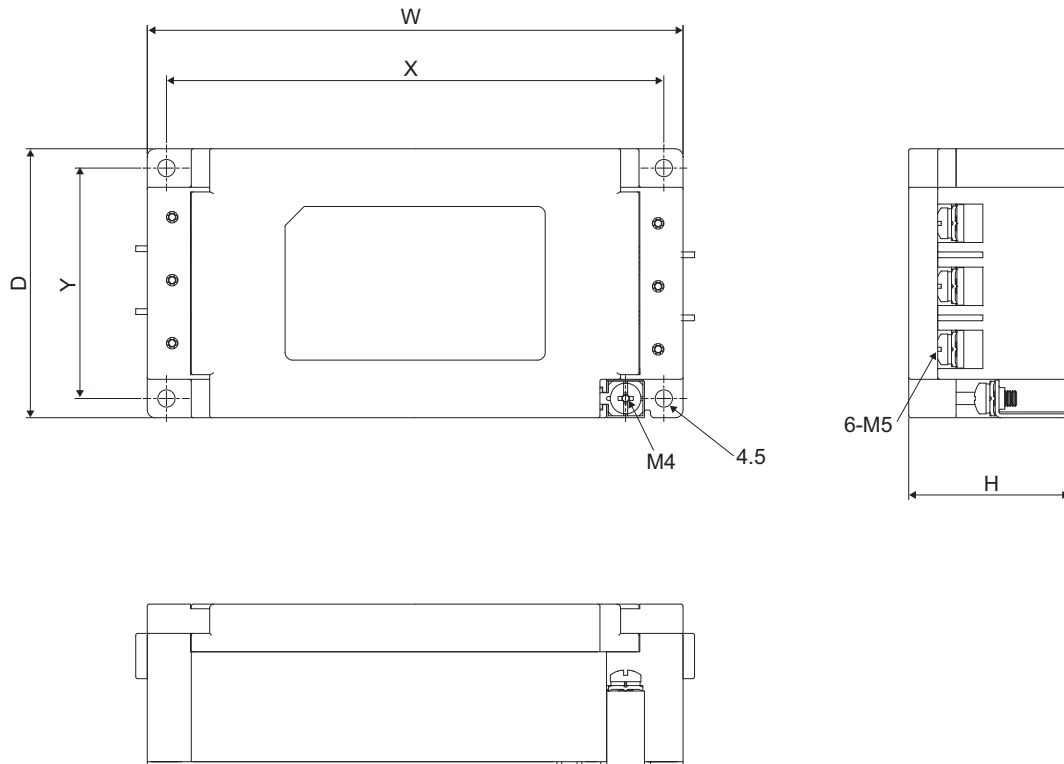

Figure D.5 EMC Filter Dimensions (2A0005, 2A0010)

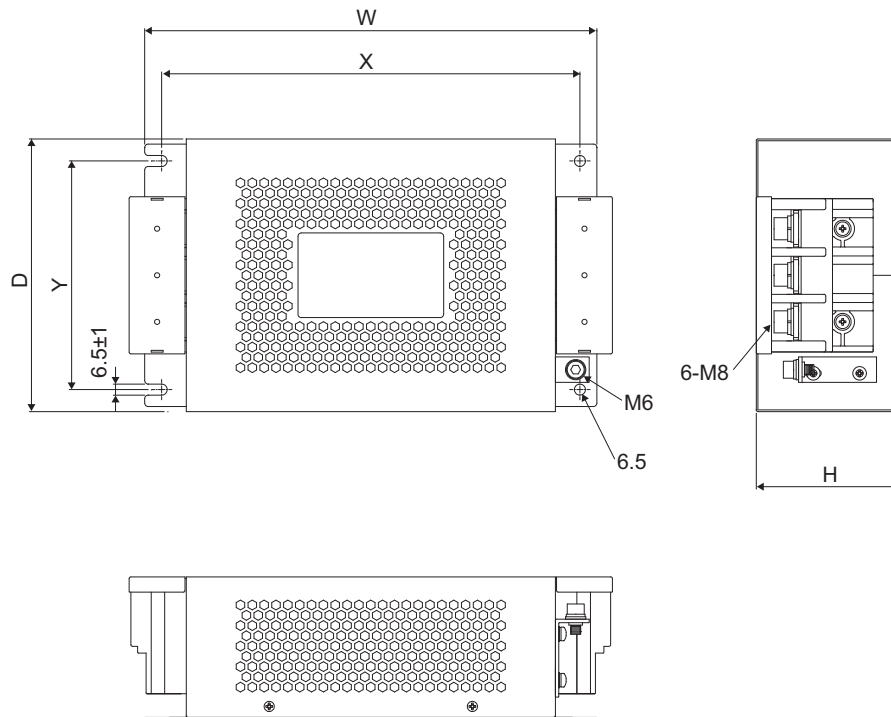

Figure D.6 EMC Filter Dimensions (2A0020)

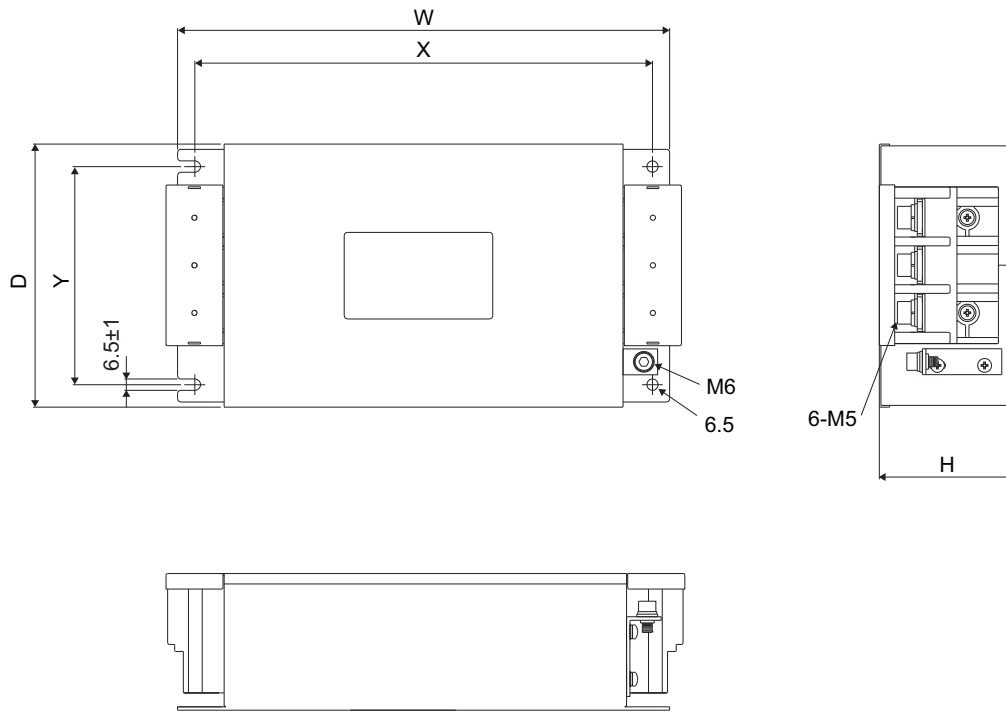

Figure D.7 EMC Filter Dimensions (2A0030)

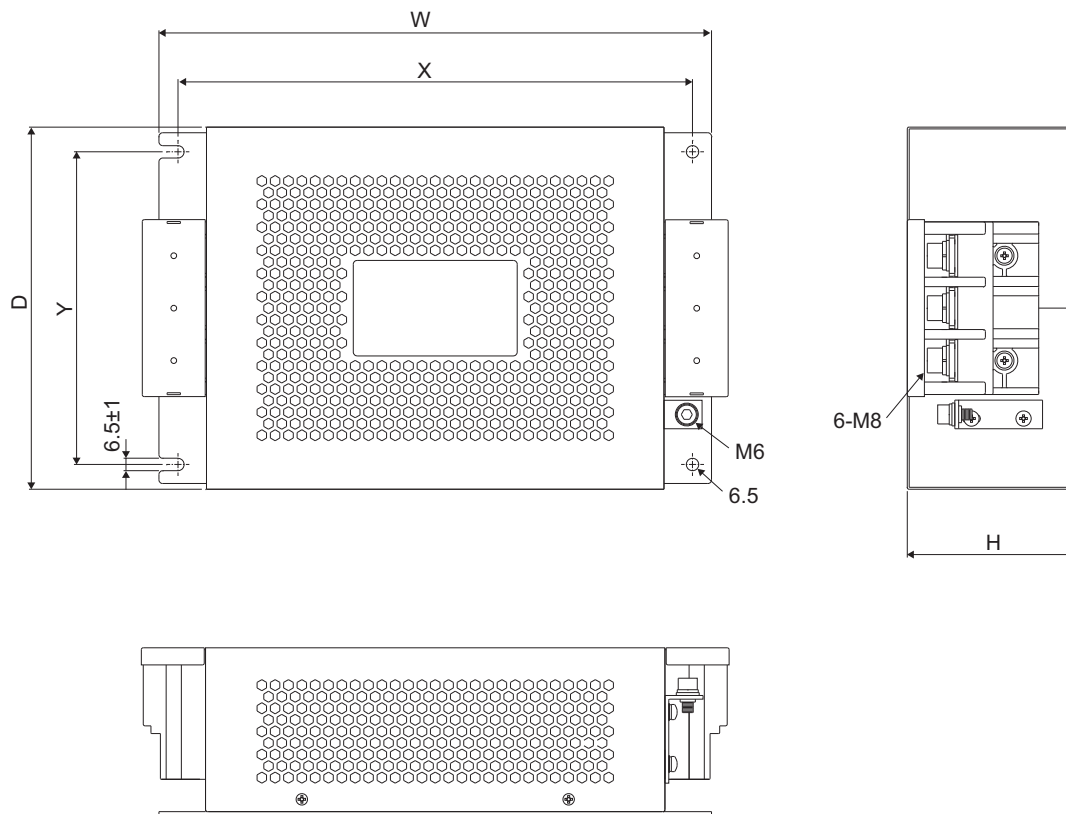

Figure D.8 EMC Filter Dimensions (2A0050)

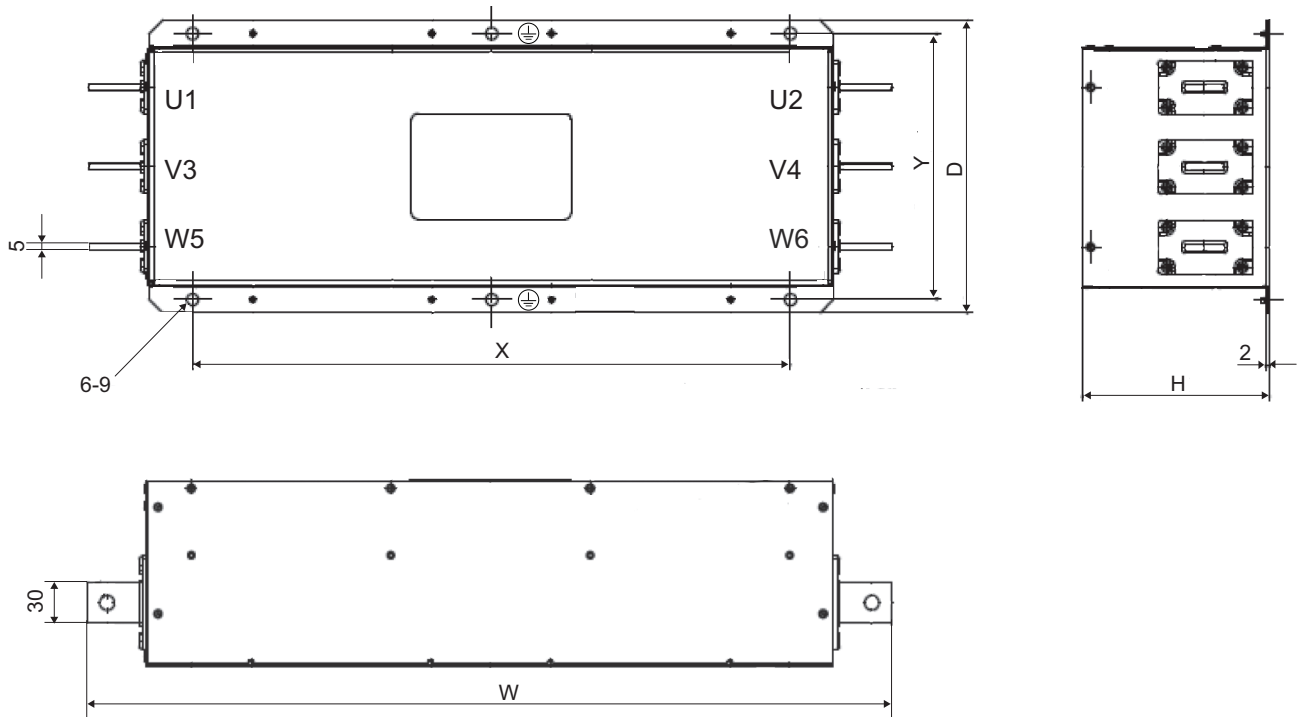

Figure D.9 EMC Filter Dimensions (2A0065 to 2A0130)

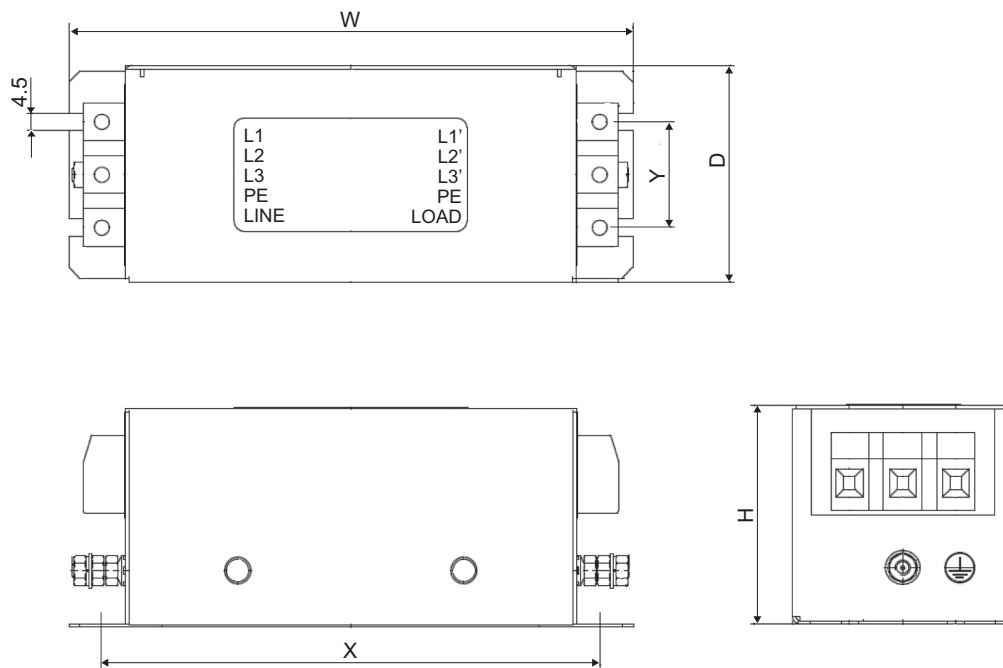

Figure D.10 EMC Filter Dimensions (4A0005, 4A0010)

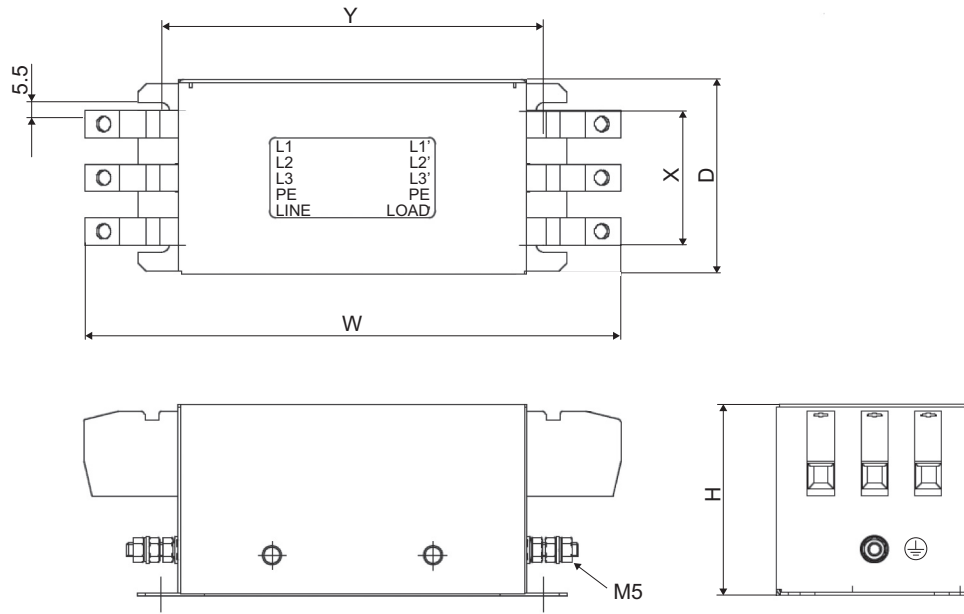

Figure D.11 EMC Filter Dimensions (4A0020)

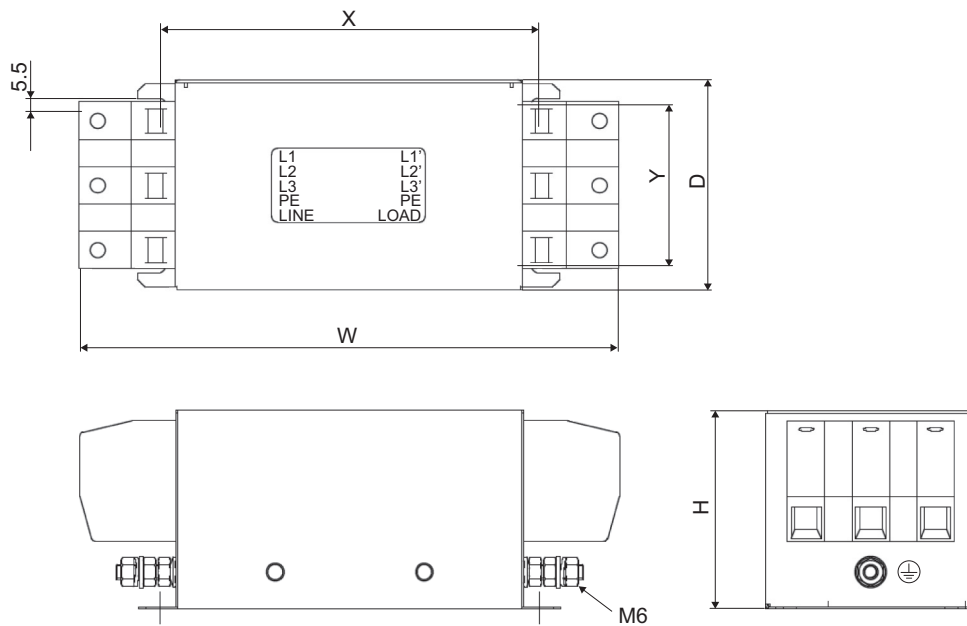

Figure D.12 EMC Filter Dimensions (4A0030, 4A0040)

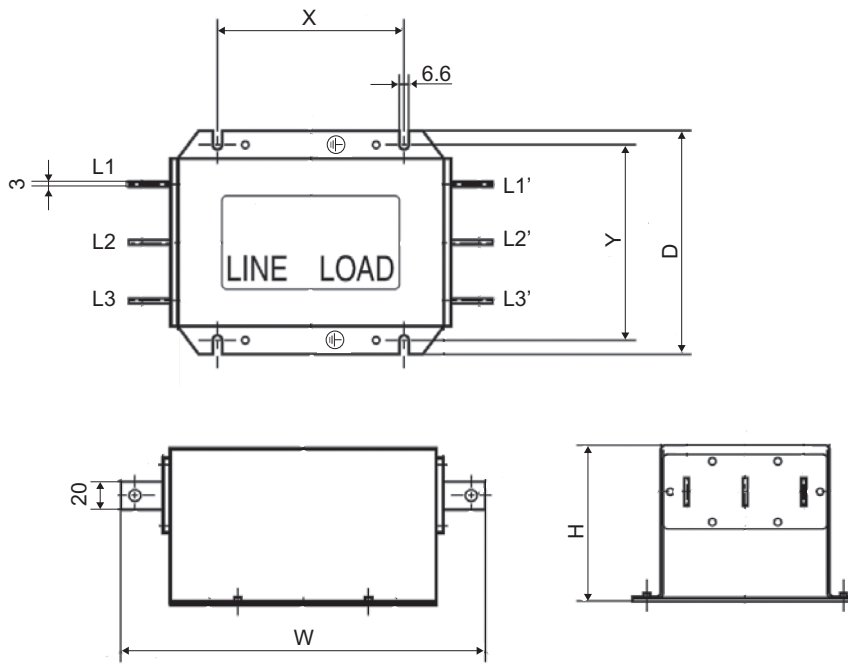

Figure D.13 EMC Filter Dimensions (4A0060, 4A0100)

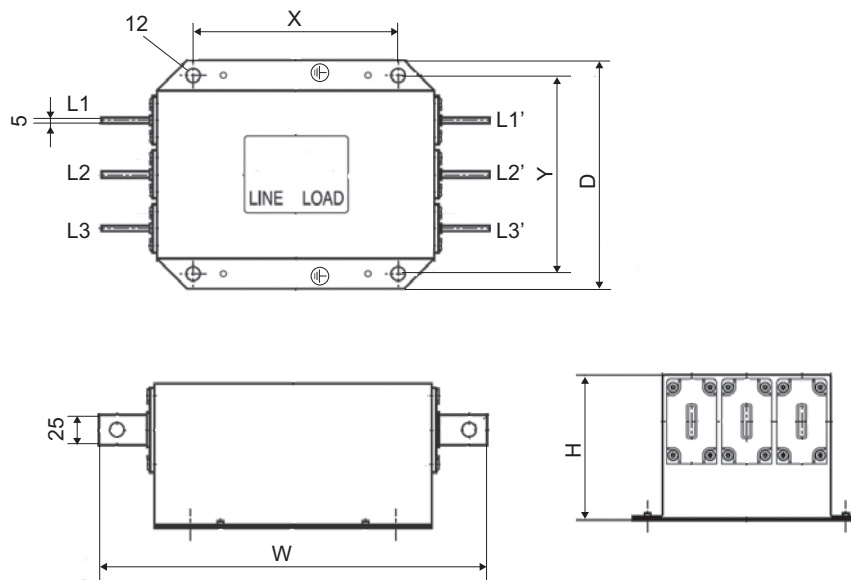

Figure D.14 EMC Filter Dimensions (4A0130, 4A0185)

## D.2 European Standards

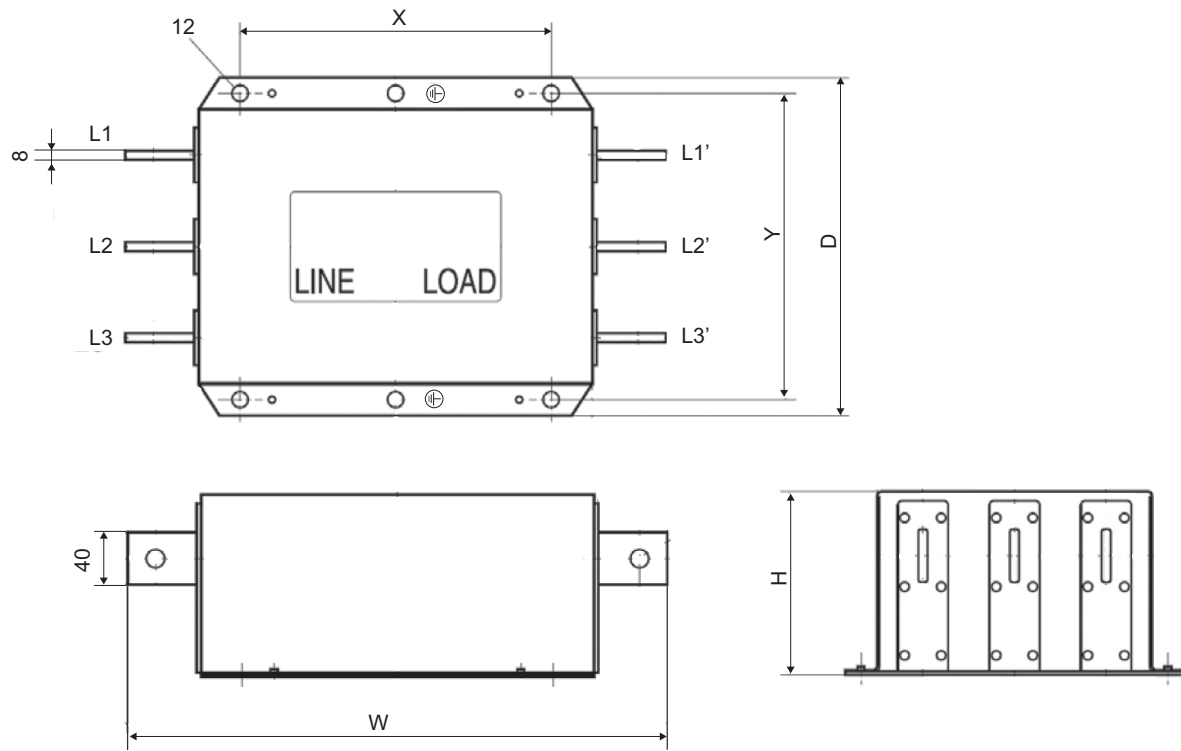

Figure D.15 EMC Filter Dimensions (4A0270, 4A0370)

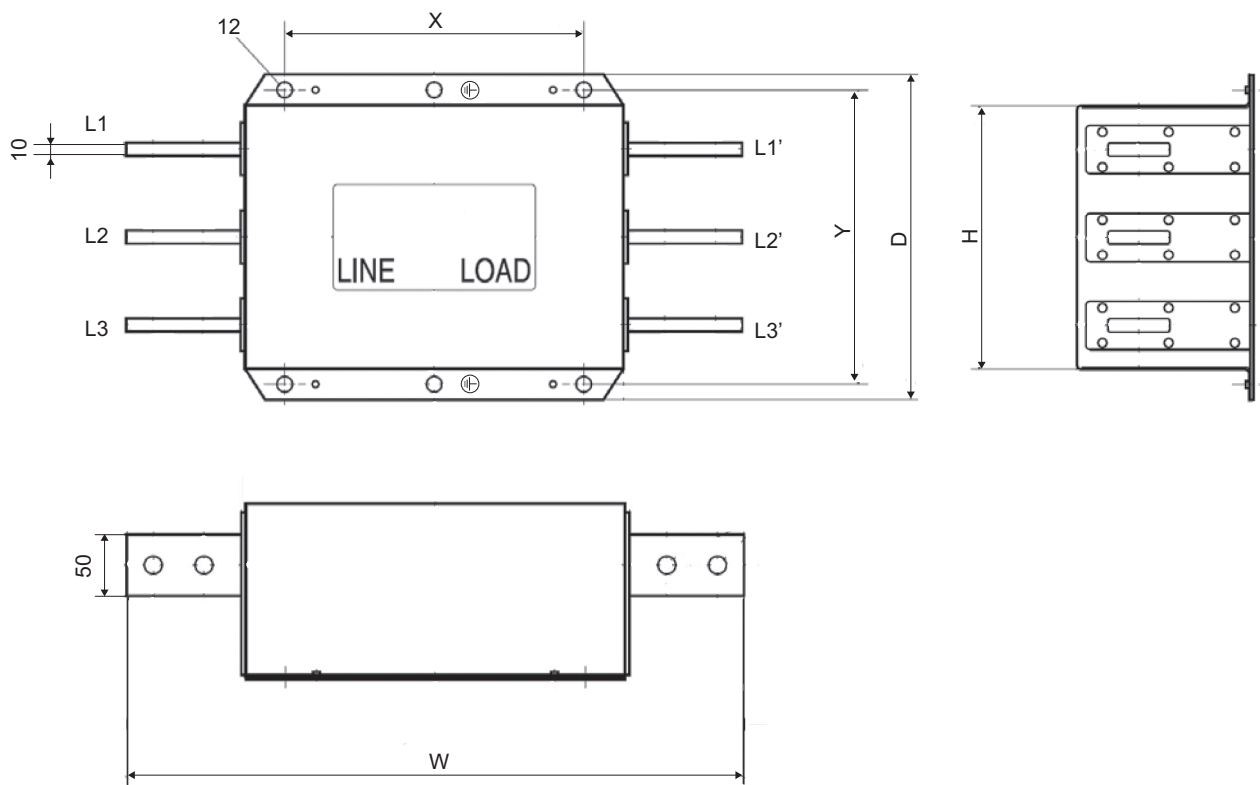

Figure D.16 EMC Filter Dimensions (4A0630)

## D.3 UL Standards

### ◆ UL Standards

The RU mark applies to products in the United States and Canada and it means that UL has performed product testing and evaluation and determined that their stringent standards for product safety have been met. For a product to receive UL certification, all components inside that product must also receive UL certification.



Figure D.17 RU Mark

### ◆ UL Standards Compliance

This converter is tested in accordance with UL standard UL508C and complies with UL requirements. To ensure continued compliance when using this converter in combination with other equipment, meet the following conditions:

#### ■ Conditions of Acceptability

1. The “3PH Input Harmonics Filter Module (3PH Input Reactor)”, “3PH Input Reactor 1”, “3PH Input Reactor For Harmonics Filter” and “3PH Input Capacitor For Harmonics Filter” shall be installed on the input of D1000 Series device.
2. The D1000 device and its peripherals shall be installed in a suitable enclosure in the end use.
3. The D1000 Series of Power Regenerative devices shall be connected to a VFD which incorporates Solid State Short Circuit Protection Circuitry and was found to comply with the High Fault Current Short Circuit Test without additional testing when:
  - a) The D1000 series uses solid state short circuit protection circuitry for compliance with the Short Circuit Test, Section 45 of UL508C, 3rd edition
  - b) The solid state short circuit protection circuitry is used in accordance with 45.1.3 of UL508C, 3rd edition.

#### ■ Installation Area

Do not install the converter to an area greater than pollution degree 2 (UL standard).

#### ■ Ambient Temperature

IP00/Open Type enclosure: -10°C to +50°C (14°F to 122°F)

IP20/Open Type enclosure: -10°C to +40°C (14°F to 104°F)

#### ■ Main Circuit Terminal Wiring

Yaskawa recommends using closed-loop crimp terminals on all converter models. To maintain UL/cUL or CSA approval, UL Listed or CSA Certified closed-loop crimp terminals are specifically required when wiring the converter main circuit terminals on models 2A0030 to 2A0130, 4A0030 to 4A0630. Use only the tools recommended by the terminal manufacturer for crimping. Refer to [Closed-Loop Crimp Terminal Recommendations on page 251](#) for closed-loop crimp terminal recommendations. The wire gauges listed in the following tables are Yaskawa recommendations. Refer to local codes for proper wire gauge selections.

**Note:** The mark ⊕ indicates the terminals for protective ground connection as defined in IEC/EN 60417-5019.  
 Grounding impedance:  
 200 V: 100 Ω or less  
 400 V: 10 Ω or less

## D.3 UL Standards

### Wire Gauges and Tightening Torques

Table D.5 Wire Gauge and Torque Specifications (Three-Phase 200 V Class)

Model	Terminal	Recomm. Gauge AWG, kcmil	Applicable Gauge AWG, kcmil	Screw Size	Tightening Torque N·m (lb·in.)
2A0005	R/L1, S/L2, T/L3	12	12 to 6	M4	2.1 to 2.3 (18.6 to 20.4)
	⊖, ⊕	12	12 to 6	M4	2.1 to 2.3 (18.6 to 20.4)
	r1/e11, $\sphericalangle$ 1/e21, t1/e31	14	14	M3.5	0.8 to 1.0 (7.1 to 8.9)
	⊕	10	16 to 10	M6	5.4 to 6.0 (47.8 to 53.1)
2A0010	R/L1, S/L2, T/L3	8	8 to 6	M4	2.1 to 2.3 (18.6 to 20.4)
	⊖, ⊕	8	8 to 6	M4	2.1 to 2.3 (18.6 to 20.4)
	r1/e11, $\sphericalangle$ 1/e21, t1/e31	14	14	M3.5	0.8 to 1.0 (7.1 to 8.9)
	⊕	10	12 to 10	M6	5.4 to 6.0 (47.8 to 53.1)
2A0020	R/L1, S/L2, T/L3	4	4 to 1	M6	3.6 to 4.0 (31.9 to 35.4)
	⊖, ⊕	4	4 to 1	M6	3.6 to 4.0 (31.9 to 35.4)
	r1/e11, $\sphericalangle$ 1/e21, t1/e31	14	14	M3.5	0.8 to 1.0 (7.1 to 8.9)
	⊕	6	8 to 6	M6	5.4 to 6.0 (47.8 to 53.1)
2A0030	R/L1, S/L2, T/L3	2	2 to 2/0	M8	5.4 to 6.0 (47.8 to 53.1)
	⊖, ⊕	2	2 to 2/0	M8	5.4 to 6.0 (47.8 to 53.1)
	r1/e11, $\sphericalangle$ 1/e21, t1/e31	14	14 to 10	M4	1.1 to 1.2 (9.7 to 10.6)
	⊕	4	6 to 4	M8	9.0 to 11 (79.7 to 97.4)
2A0050	R/L1, S/L2, T/L3	3 × 2P	3 to 2/0	M8	5.4 to 6.0 (47.8 to 53.1)
	⊖, ⊕	1/0 × 2P	1/0 to 2/0	M8	5.4 to 6.0 (47.8 to 53.1)
	r1/e11, $\sphericalangle$ 1/e21, t1/e31	14	14 to 10	M4	1.1 to 1.2 (9.7 to 10.6)
	⊕	4	4	M10	18 to 23 (159 to 204)
2A0065	R/L1, S/L2, T/L3	3/0 × 2P	3/0 to 300	M12	32 to 40 (283 to 354)
	⊖, ⊕	3/0 × 2P	3/0 to 300	M12	32 to 40 (283 to 354)
	r1/e11, $\sphericalangle$ 1/e21, t1/e31	14	14 to 10	M4	1.1 to 1.2 (9.7 to 10.6)
	⊕	1	1 to 1/0	M12	32 to 40 (283 to 354)



Model	Terminal	Recomm. Gauge AWG, kcmil	Applicable Gauge AWG, kcmil	Screw Size	Tightening Torque N·m (lb·in.)
2A0090	R/L1, S/L2, T/L3	3/0 × 2P	3/0 to 300	M12	32 to 40 (283 to 354)
	⊖, ⊕	3/0 × 2P	3/0 to 300	M12	32 to 40 (283 to 354)
	r1/ℓ11, s1/ℓ21, t1/ℓ31	14	14 to 10	M4	1.1 to 1.2 (9.7 to 10.6)
	⊕	1/0	1/0 to 4/0	M12	32 to 40 (283 to 354)
2A0130	R/L1, S/L2, T/L3	300 × 2P	300 to 600	M12	32 to 40 (283 to 354)
	⊖, ⊕	300 × 2P	300 to 600	M12	32 to 40 (283 to 354)
	r1/ℓ11, s1/ℓ21, t1/ℓ31	14	14 to 10	M4	1.1 to 1.2 (9.7 to 10.6)
	⊕	2/0	2/0 to 4/0	M12	32 to 40 (283 to 354)

Table D.6 Wire Gauge and Torque Specifications (Three-Phase 400 V Class)

Model	Terminal	Recomm. Gauge AWG, kcmil	Applicable Gauge AWG, kcmil	Screw Size	Tightening Torque N·m (lb·in.)
4A0005	R/L1, S/L2, T/L3	12	12 to 6	M4	2.1 to 2.3 (18.6 to 20.4)
	⊖, ⊕	12	12 to 6	M4	2.1 to 2.3 (18.6 to 20.4)
	r1/ℓ11, s1/ℓ21, t1/ℓ31	14	14	M3.5	0.8 to 1.0 (7.1 to 8.9)
	⊕	12	14 to 12	M6	5.4 to 6.0 (47.8 to 53.1)
4A0010	R/L1, S/L2, T/L3	12	12 to 6	M4	2.1 to 2.3 (18.6 to 20.4)
	⊖, ⊕	12	12 to 6	M4	2.1 to 2.3 (18.6 to 20.4)
	r1/ℓ11, s1/ℓ21, t1/ℓ31	14	14	M3.5	0.8 to 1.0 (7.1 to 8.9)
	⊕	10	12 to 10	M6	5.4 to 6.0 (47.8 to 53.1)
4A0020	R/L1, S/L2, T/L3	8	8 to 1	M6	3.6 to 4.0 (31.9 to 35.4)
	⊖, ⊕	8	8 to 1	M6	3.6 to 4.0 (31.9 to 35.4)
	r1/ℓ11, s1/ℓ21, t1/ℓ31	14	14	M3.5	0.8 to 1.0 (7.1 to 8.9)
	⊕	8	10 to 8	M6	5.4 to 6.0 (47.8 to 53.1)
4A0030	R/L1, S/L2, T/L3	6	6 to 2/0	M8	5.4 to 6.0 (47.8 to 53.1)
	⊖, ⊕	6	6 to 2/0	M8	5.4 to 6.0 (47.8 to 53.1)
	r1/ℓ11, s1/ℓ21, t1/ℓ31	14	14 to 10	M4	1.1 to 1.2 (9.7 to 10.6)
	⊕	6	8 to 6	M8	9.0 to 11 (79.7 to 97.4)

### D.3 UL Standards

Model	Terminal	Recomm. Gauge AWG, kcmil	Applicable Gauge AWG, kcmil	Screw Size	Tightening Torque N·m (lb·in.)
4A0040	R/L1, S/L2, T/L3	4	4 to 2/0	M8	5.4 to 6.0 (47.8 to 53.1)
	⊖, ⊕	4	4 to 2/0	M8	5.4 to 6.0 (47.8 to 53.1)
	r1/ℓ11, Ⓜ1/ℓ21, t1/ℓ31	14	14 to 10	M4	1.1 to 1.2 (9.7 to 10.6)
	⊕	6	6	M8	9.0 to 11 (79.7 to 97.4)
4A0060	R/L1, S/L2, T/L3	2	2 to 2/0	M8	5.4 to 6.0 (47.8 to 53.1)
	⊖, ⊕	2	2 to 2/0	M8	5.4 to 6.0 (47.8 to 53.1)
	r1/ℓ11, Ⓜ1/ℓ21, t1/ℓ31	14	14 to 10	M4	1.1 to 1.2 (9.7 to 10.6)
	⊕	6	6	M10	18 to 23 (159 to 204)
4A0100	R/L1, S/L2, T/L3	3 × 2P	3 to 2/0	M8	5.4 to 6.0 (47.8 to 53.1)
	⊖, ⊕	1/0 × 2P	1/0 to 2/0	M8	5.4 to 6.0 (47.8 to 53.1)
	r1/ℓ11, Ⓜ1/ℓ21, t1/ℓ31	14	14 to 10	M4	1.1 to 1.2 (9.7 to 10.6)
	⊕	3	3	M10	18 to 23 (159 to 204)
4A0130	R/L1, S/L2, T/L3	3/0 × 2P	3/0 to 600	M10	18 to 23 (159 to 204)
	⊖, ⊕	3/0 × 2P	3/0 to 600	M10	18 to 23 (159 to 204)
	r1/ℓ11, Ⓜ1/ℓ21, t1/ℓ31	14	14 to 10	M4	1.1 to 1.2 (9.7 to 10.6)
	⊕	1/0	1/0 to 2/0	M10	18 to 23 (159 to 204)
4A0185	R/L1, S/L2, T/L3	3/0 × 2P	3/0 to 600	M12	32 to 40 (283 to 354)
	⊖, ⊕	3/0 × 2P	3/0 to 600	M12	32 to 40 (283 to 354)
	r1/ℓ11, Ⓜ1/ℓ21, t1/ℓ31	14	14 to 10	M4	1.1 to 1.2 (9.7 to 10.6)
	⊕	1/0	1/0 to 4/0	M12	32 to 40 (283 to 354)
4A0270	R/L1, S/L2, T/L3	300 × 2P	300	M12	32 to 40 (283 to 354)
	⊖, ⊕	300 × 2P	300	M12	32 to 40 (283 to 354)
	r1/ℓ11, Ⓜ1/ℓ21, t1/ℓ31	14	14 to 10	M4	1.1 to 1.2 (9.7 to 10.6)
	⊕	2/0	2/0 to 4/0	M12	32 to 40 (283 to 354)

Model	Terminal	Recomm. Gauge AWG, kcmil	Applicable Gauge AWG, kcmil	Screw Size	Tightening Torque N·m (lb·in.)
4A0370	R/L1, S/L2, T/L3	4/0 × 4P	4/0 to 300	M12	32 to 40 (283 to 354)
	⊖, ⊕	4/0 × 4P	4/0 to 300	M12	32 to 40 (283 to 354)
	r1/ℓ11, s1/ℓ21, t1/ℓ31	14	14 to 10	M4	1.1 to 1.2 (9.7 to 10.6)
	⊕	4/0	2/0 to 300	M12	32 to 40 (283 to 354)
4A0630	R/L1, S/L2, T/L3	4/0 × 8P	4/0 to 300	M12	32 to 40 (283 to 354)
	⊖, ⊕	4/0 × 8P	4/0 to 300	M12	32 to 40 (283 to 354)
	r1/ℓ11, s1/ℓ21, t1/ℓ31	14	14 to 10	M4	1.1 to 1.2 (9.7 to 10.6)
	⊕	250	2/0 to 300	M12	32 to 40 (283 to 354)

### Closed-Loop Crimp Terminal Recommendations

Yaskawa recommends UL Listed or CSA Certified crimp terminals made by JST and Tokyo DIP (or equivalent) for the insulation cap. [Table D.7](#) matches the wire gauges and terminal screw sizes with Yaskawa-recommended crimp terminals, tools, and insulation caps. Refer to the appropriate Wire Gauge and Torque Specifications table for the wire gauge and screw size for your converter model. Place orders with a Yaskawa representative or the Yaskawa sales department. The closed-loop crimp terminal sizes and values listed in [Table D.7](#) are Yaskawa recommendations. Wire gauge values shown in [Table D.7](#) are the recommended values. Refer to local codes for proper selections.

**Table D.7 Closed-Loop Crimp Terminal Size**

Model	Wire Gauge (AWG, kcmil)		Screw Size	Crimp Terminal Model Number	Tool		Insulation Cap Model No.	Code <1>
	R/L1·S/L2·T/L3	⊖, ⊕			Machine No.	Die Jaw		
<b>200 V Class</b>								
2A0005	12		M4	R5.5-4	YA-4	AD-900	TP-005	100-054-029
	10			R5.5-4	YA-4	AD-900	TP-005	100-054-029
	8			8-4	YA-4	AD-901	TP-008	100-054-031
	6			14-NK4	YA-4	AD-902	TP-014	100-054-033
2A0010	8		M4	8-4	YA-4	AD-901	TP-008	100-054-031
	6			14-NK4	YA-4	AD-902	TP-014	100-054-033
2A0020	4		M6	R22-6	YA-5	AD-953	TP-022	100-051-262
	3			38-6	YA-5	AD-954	TP-038	100-092-577
	2			38-6	YA-5	AD-954	TP-038	100-092-577
	1			60-6	YA-5	AD-955	TP-060	100-092-578
2A0030	2		M8	R38-8	YA-5	AD-954	TP-038	100-051-264
	1			R60-8	YA-5	AD-955	TP-060	100-051-265
	1/0			R60-8	YA-5	AD-955	TP-060	100-051-265
	2/0			80-8	YF-1, YET-300-1	TD-323 TD-312	TP-080	100-092-579
2A0050	3 × 2P	–	M8	R38-8	YA-5	AD-954	TP-038	100-051-264
	2 × 2P	–		R38-8	YA-5	AD-954	TP-038	100-051-264
	1 × 2P	–		R60-8	YA-5	AD-955	TP-060	100-051-265
	1/0 × 2P	1/0 × 2P		R60-8	YA-5	AD-955	TP-060	100-051-265
	2/0 × 2P	2/0 × 2P		80-8	YF-1, YET-300-1	TD-323, TD-312	TP-080	100-092-579

### D.3 UL Standards

Model	Wire Gauge (AWG, kcmil)		Screw Size	Crimp Terminal Model Number	Tool		Insulation Cap Model No.	Code <†>
	R/L1·S/L2·T/L3	⊖, ⊕			Machine No.	Die Jaw		
2A0065	3/0 × 2P		M12	80-L12	YF-1, YET-300-1	TD-323, TD-312	TP-080	100-051-558
	4/0 × 2P			100-L12	YF-1, YET-300-1	TD-324, TD-312	TP-100	100-051-560
	250			150-L12	YF-1, YET-300-1	TD-325, TD-313	TP-150	100-051-562
	300			150-L12	YF-1, YET-300-1	TD-325, TD-313	TP-150	100-051-562
2A0090	3/0 × 2P		M12	80-L12	YF-1, YET-300-1	TD-323, TD-312	TP-080	100-051-558
	4/0 × 2P			100-L12	YF-1, YET-300-1	TD-324, TD-312	TP-100	100-051-560
	250 × 2P			150-L12	YF-1, YET-300-1	TD-325, TD-313	TP-150	100-051-562
	300 × 2P			150-L12	YF-1, YET-300-1	TD-325, TD-313	TP-150	100-051-562
<b>400 V Class</b>								
4A0005	12		M4	R5.5-4	YA-4	AD-900	TP-005	100-054-029
	10			R5.5-4	YA-4	AD-900	TP-005	100-054-029
	8			8-4	YA-4	AD-901	TP-008	100-054-031
	6			14-NK4	YA-4	AD-902	TP-014	100-054-033
4A0010	12		M4	R5.5-4	YA-4	AD-900	TP-005	100-054-029
	10			R5.5-4	YA-4	AD-900	TP-005	100-054-029
	8			8-4	YA-4	AD-901	TP-008	100-054-031
	6			14-NK4	YA-4	AD-902	TP-014	100-054-033
4A0020	8		M6	R8-6	YA-4	AD-901	TP-008	100-092-620
	6			R14-6	YA-4	AD-902	TP-014	100-051-261
	4			R22-6	YA-5	AD-953	TP-022	100-051-262
	3			38-6	YA-5	AD-954	TP-038	100-092-577
	2			38-6	YA-5	AD-954	TP-038	100-092-577
	1			60-6	YA-5	AD-955	TP-060	100-092-578
4A0030	6		M8	R14-8	YA-4	AD-902	TP-014	100-051-035
	4			R22-8	YA-5	AD-953	TP-022	100-051-263
	3			R38-8	YA-5	AD-954	TP-038	100-051-264
	2			R38-8	YA-5	AD-954	TP-038	100-051-264
	1			R60-8	YA-5	AD-955	TP-060	100-051-265
	1/0			R60-8	YA-5	AD-955	TP-060	100-051-265
	2/0			80-8	YF-1, YET-300-1	TD-323, TD-312	TP-080	100-092-579
4A0040	4		M8	R22-8	YA-5	AD-953	TP-022	100-051-263
	3			R38-8	YA-5	AD-954	TP-038	100-051-264
	2			R38-8	YA-5	AD-954	TP-038	100-051-264
	1			R60-8	YA-5	AD-955	TP-060	100-051-265
	1/0			R60-8	YA-5	AD-955	TP-060	100-051-265
	2/0			80-8	YF-1, YET-300-1	TD-323, TD-312	TP-080	100-092-579

Model	Wire Gauge (AWG, kcmil)		Screw Size	Crimp Terminal Model Number	Tool		Insulation Cap Model No.	Code <?>
	R/L1·S/L2·T/L3	⊖, ⊕			Machine No.	Die Jaw		
4A0060	2		M8	R38-8	YA-5	AD-954	TP-038	100-051-264
	1			R60-8	YA-5	AD-955	TP-060	100-051-265
	1/0			R60-8	YA-5	AD-955	TP-060	100-051-265
	2/0			80-8	YF-1, YET-300-1	TD-323, TD-312	TP-080	100-092-579
4A0100	3 × 2P	–	M8	R38-8	YA-5	AD-954	TP-038	100-051-264
	2 × 2P	–		R38-8	YA-5	AD-954	TP-038	100-051-264
	1 × 2P	–		R60-8	YA-5	AD-955	TP-060	100-051-265
	1/0 × 2P			R60-8	YA-5	AD-955	TP-060	100-051-265
	2/0 × 2P			80-8	YF-1, YET-300-1	TD-323, TD-312	TP-080	100-092-579
4A0130	3/0 × 2P		M10	80-L10	YF-1, YET-300-1	TD-323, TD-312	TP-080	100-051-557
	4/0 × 2P			100-L10	YF-1, YET-300-1	TD-324, TD-312	TP-100	100-051-559
	250 × 2P	250		150-L10	YF-1, YET-300-1	TD-325, TD-313	TP-150	100-051-561
	300			R150-10	YF-1, YET-300-1	TD-325, TD-313	TP-150	100-051-272
	350			200-10	YF-1, YET-300-1	TD-327, TD-314	TP-200	100-051-563
	400			200-10	YF-1, YET-300-1	TD-327, TD-314	TP-200	100-051-563
	500			325-10	YF-1, YET-300-1	TD-328, TD-315	TP-325	100-051-565
	600			325-10	YF-1, YET-300-1	TD-328, TD-315	TP-325	100-051-565
4A0185	3/0 × 2P		M12	80-L12	YF-1, YET-300-1	TD-323, TD-312	TP-080	100-051-557
	4/0 × 2P			100-L12	YF-1, YET-300-1	TD-324, TD-312	TP-100	100-051-559
	250 × 2P			150-L12	YF-1, YET-300-1	TD-325, TD-313	TP-150	100-051-562
	300 × 2P			150-L12	YF-1, YET-300-1	TD-325, TD-313	TP-150	100-051-562
	350 × 2P			200-L12	YF-1, YET-300-1	TD-327, TD-314	TP-200	100-051-564
	400 × 2P			200-L12	YF-1, YET-300-1	TD-327, TD-314	TP-200	100-051-564
	500			325-12	YF-1, YET-300-1	TD-328, TD-315	TP-325	100-051-277
	600			325-12	YF-1, YET-300-1	TD-328, TD-315	TP-325	100-051-277
4A0270	300 × 2P		M12	150-L12	YF-1, YET-300-1	TD-325, TD-313	TP-150	100-051-562
4A0370	4/0 × 4P		M12	100-L12	YF-1, YET-300-1	TD-324, TD-312	TP-100	100-051-559
	250 × 4P			150-L12	YF-1, YET-300-1	TD-325, TD-313	TP-150	100-051-562
	300 × 4P			150-L12	YF-1, YET-300-1	TD-325, TD-313	TP-150	100-051-562

## D.3 UL Standards

Model	Wire Gauge (AWG, kcmil)		Screw Size	Crimp Terminal Model Number	Tool		Insulation Cap Model No.	Code <1>
	R/L1·S/L2·T/L3	⊖, ⊕			Machine No.	Die Jaw		
4A0630	4/0 × 8P		M12	100-L12	YF-1, YET-300-1	TD-324, TD-312	TP-100	100-051-559
	250 × 8P			150-L12	YF-1, YET-300-1	TD-325, TD-313	TP-150	100-051-562
	300 × 8P			150-L12	YF-1, YET-300-1	TD-325, TD-313	TP-150	100-051-562

<1> Codes refer to a set of three crimp terminals and three insulation caps. Prepare input and output wiring using two sets for each connection.

Example 1: Model 4A0130 with 300 kcmil for both input and output require one set for input terminals and one set for output terminals, so the user should order two sets of [100-051-272].

Example 2: Model 4A0185 with 300 kcmil × 2P for both input and output require two sets for input terminals and two sets for output terminals, so the user should order four sets of [100-051-562].

**Note:** Use crimp insulated terminals or insulated shrink tubing for wiring connections. Wires should have a continuous maximum allowable temperature of 75°C 600 Vac UL-approved vinyl-sheathed insulation.

Model	Wire Gauge (AWG, kcmil)	Screw Size	Crimp Terminal Model Number	Tool		Insulation Cap Model No.	Code
	r1/l11, s1/l21, t1/l31			Machine No.	Die Jaw		
2A0005 to 2A0020, 4A0005 to 4A0020	14	M3.5	R2-3.5	YA-4	AD-900	TP-003	100-106-516
2A0030 to 2A0130, 4A0030 to 4A0630	14	M4	R2-4	YA-4	AD-900	TP-003	100-106-517

### ◆ Installing Standard Configuration Devices

**NOTICE:** If a fuse is open or a Ground Fault Circuit Interrupter (GFCI) is tripped, check the wiring and the selection of the peripheral devices. Check the wiring and the selection of peripheral devices to identify the cause. Contact Yaskawa before restarting the converter or the peripheral devices if the cause cannot be identified.

Refer to *Standard Configuration Devices on page 236* for details on the standard configuration devices.

### ■ Low Voltage Wiring for Control Circuit Terminals

Wire low voltage wires with NEC Class 1 circuit conductors. Refer to national state or local codes for wiring. The external power supply shall be a CSA certified or cUL Listed Class 2 power source only or equivalent.

**Table D.8 Control Circuit Terminal Power Supply**

Input / Output	Terminal Signal	Power Supply Specifications
Multi-function digital inputs	S1, S2, S3, S4, S5, S6, S7, S8, SC	Use the internal LVLC power supply of the converter. Use class 2 for external power supply.
Multi function analog inputs	+V, -V, A1, A2, A3, AC	

### ■ Converter Short-Circuit Rating

This converter is suitable for use on a circuit capable of delivering not more than 100,000 RMS symmetrical amperes, 240 Vac for 200 V class converters and 480 Vac for 400 V class converters, when protected by fuses as specified on the *Table D.8*.

### ◆ Precautionary Notes on External Heatsink (IP00/Open Type enclosure)

When using an external heatsink, UL compliance requires that exposed capacitors in the main circuit are covered to prevent injury to surrounding personnel.

The portion of the external heatsink that projects out can either be protected with the enclosure, or with the appropriate capacitor cover after converter installation is complete. Use the table below to match converter models and capacitor cover. Capacitor covers can be ordered from a Yaskawa representative or directly from the Yaskawa sales department. The table below lists available capacitor covers.

**Table D.9 Capacitor Cover**

Model	Code Number	Figure
2A0030	100-061-274	<i>Figure D.18</i>
2A0050	100-061-275	
2A0065	100-061-277	
2A0090	100-061-277	
2A0130	100-061-278	
4A0030	100-061-274	
4A0040	100-061-274	
4A0060	100-061-275	
4A0100	100-061-275	
4A0130	100-061-278	
4A0185	100-061-278	
4A0270	100-061-280	
4A0370	100-061-280	
4A0630	100-061-281 <1>	

<1> Requires two sets.

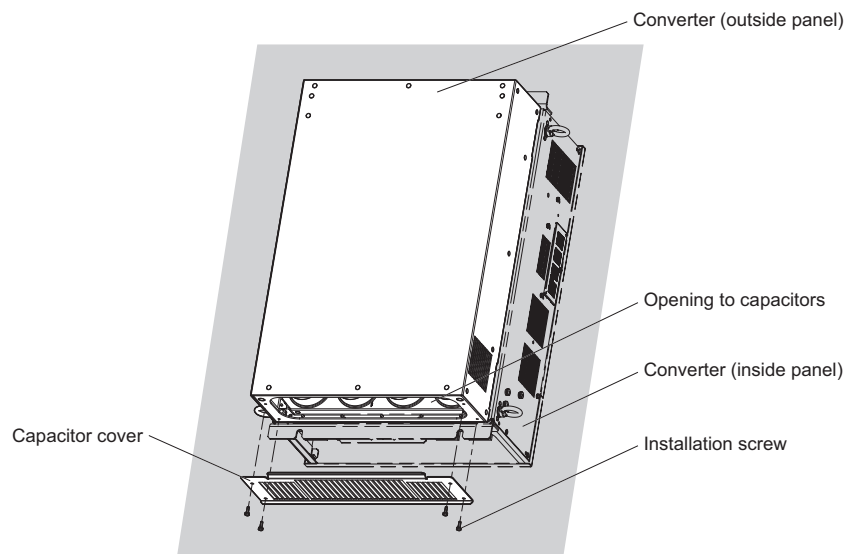

**Figure D.18 Capacitor Cover (2A0030 to 2A0130, 4A0030 to 4A0370)**

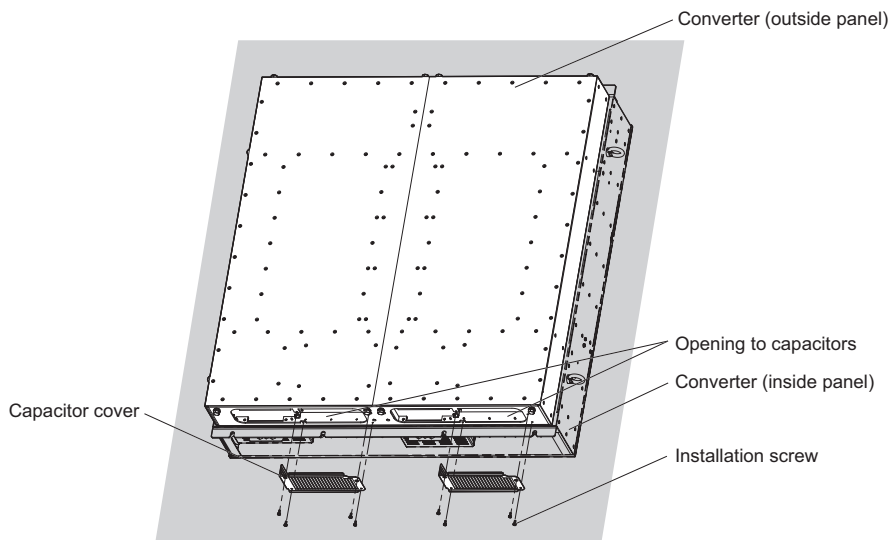

**Figure D.19 Capacitor Cover (4A0630)**



## D.4 CSA Standards Compliance

### ◆ Conditions of Acceptability

Refer to *Conditions of Acceptability on page 247*.

### ◆ Installing Standard Configuration Devices

Refer to *Standard Configuration Devices on page 236* for details on the standard configuration devices.

### ◆ Main Circuit Terminal Wiring

Yaskawa recommends using closed-loop crimp terminals on all converter models. To maintain UL/cUL or CSA approval, UL Listed or CSA Certified closed-loop crimp terminals are specifically required when wiring the converter main circuit terminals on models 2A0030 to 2A0130, 4A0030 to 4A0630. Use only the tools recommended by the terminal manufacturer for crimping. Refer to *Closed-Loop Crimp Terminal Recommendations on page 251* for closed-loop crimp terminal recommendations. The wire gauges listed in the following tables are Yaskawa recommendations. Refer to local codes for proper wire gauge selections.

The external power supply shall be a CSA certified or cUL Listed Class 2 power source only or equivalent. Refer to *Table D.8* for details.

### ◆ CSA for Industrial Control Equipment

The D1000 is CSA certified as Industrial Control Equipment Class 3211.

Specifically, the D1000 is certified to: CAN/CSA C22.2 No.0-10 and CAN/CSA C22.2 No.14-13.



Figure D.20 CSA Mark

### ◆ CSA for Elevator Equipment

The D1000 is tested and complies with CSA B44.1-11/ASME A17.5-2011 standard.

This standard is used by CSA to evaluate the D1000 to Class 2411 (Elevator Equipment).



CSA B44.1 /  
ASME A17.5

Figure D.21 CSA B44.1-11/ASME A17.5-2011 Mark

## Revision History

The revision dates and the numbers of the revised manuals appear on the bottom of the back cover.



MANUAL NO. TOEP C710656 07B

Published in Japan December 2013 13-7 

└─ Revision number

└─ Date of original publication

└─ Date of publication

Date of Publication	Revision Number	Section	Revised Content
January 2015		All	Revision: Reviewed and corrected the entire documentation.
		5.2	Revision: Cause and possible solutions for oC and ov
		B.2	Deletion: C6-02 (Carrier Frequency Selection) Addition: • H2-06 (kWh Monitor Pulse Output Unit Selection) • H2-□□ = 39 (Power Consumption), 3A (Regenerated Power) • L9-08 (DC5 Conveter Unit Replacement Selection) • L9-09 (DC3 Conveter Unit Replacement Selection)
		D.2	Revision: Standard Configuration Devices
		D.3	Addition: Conditions of Acceptability Revision: Installing Standard Configuration Devices Deletion: CSA Standards Compliance
		D.4	Addition: CSA Standards Compliance
		Back cover	Revision: Address
December 2013		All Chapter	Revision: Reviewed and corrected entire documentation.
		Appendix D	Revision: Recommended Branch Circuit Protection Addition: CSA Standard Compliance
July 2013	–	–	First Edition.

# YASKAWA D1000 Series

## Power Regenerative Converter

### Instruction Manual

---

**YASKAWA AMERICA, INC.**

2121, Norman Drive South, Waukegan, IL 60085, U.S.A.  
Phone: 1-800-YASKAWA (927-5292) or 1-847-887-7000 Fax: 1-847-887-7310  
<http://www.yaskawa.com>

**DRIVE CENTER (INVERTER PLANT)**

2-13-1, Nishimiyaichi, Yukuhashi, Fukuoka, 824-8511, Japan  
Phone: 81-930-25-3844 Fax: 81-930-25-4369  
<http://www.yaskawa.co.jp>

**YASKAWA ELECTRIC CORPORATION**

New Pier Takeshiba South Tower, 1-16-1, Kaigan, Minatoku, Tokyo, 105-6891, Japan  
Phone: 81-3-5402-4502 Fax: 81-3-5402-4580  
<http://www.yaskawa.co.jp>

**YASKAWA ELÉTRICO DO BRASIL LTDA.**

777, Avenida Piraporinha, Diadema, São Paulo, 09950-000, Brasil  
Phone: 55-11-3585-1100 Fax: 55-11-3585-1187  
<http://www.yaskawa.com.br>

**YASKAWA EUROPE GmbH**

185, Hauptstraße, Eschborn, 65760, Germany  
Phone: 49-6196-569-300 Fax: 49-6196-569-398  
<http://www.yaskawa.eu.com>

**YASKAWA ELECTRIC KOREA CORPORATION**

9F, Kyobo Securities Bldg., 26-4, Yeouido-dong, Yeongdeungpo-gu, Seoul, 150-737, Korea  
Phone: 82-2-784-7844 Fax: 82-2-784-8495  
<http://www.yaskawa.co.kr>

**YASKAWA ELECTRIC (SINGAPORE) PTE. LTD.**

151, Lorong Chuan, #04-02A, New Tech Park, 556741, Singapore  
Phone: 65-6282-3003 Fax: 65-6289-3003  
<http://www.yaskawa.com.sg>

**YASKAWA ELECTRIC (THAILAND) CO., LTD.**

252/125-126, 27th Floor, Muang Thai-Phatra Tower B, Rachadapisek Road, Huaykwang, Bangkok, 10310, Thailand  
Phone: 66-2693-2200 Fax: 66-2693-4200  
<http://www.yaskawa.co.th>

**YASKAWA ELECTRIC (CHINA) CO., LTD.**

22F, One Corporate Avenue, No.222, Hubin Road, Shanghai, 200021, China  
Phone: 86-21-5385-2200 Fax: 86-21-5385-3299  
<http://www.yaskawa.com.cn>

**YASKAWA ELECTRIC (CHINA) CO., LTD. BEIJING OFFICE**

Room 1011, Tower W3 Oriental Plaza, No. 1, East Chang An Ave.,  
Dong Cheng District, Beijing, 100738, China  
Phone: 86-10-8518-4086 Fax: 86-10-8518-4082

**YASKAWA ELECTRIC TAIWAN CORPORATION**

9F, 16, Nanking E. Rd., Sec. 3, Taipei, 104, Taiwan  
Phone: 886-2-2502-5003 Fax: 886-2-2505-1280

**YASKAWA INDIA PRIVATE LIMITED**

#17/A, Electronics City, Hosur Road, Bangalore, 560 100 (Karnataka), India  
Phone: 91-80-4244-1900 Fax: 91-80-4244-1901  
<http://www.yaskawaindia.in>



YASKAWA ELECTRIC CORPORATION

In the event that the end user of this product is to be the military and said product is to be employed in any weapons systems or the manufacture thereof, the export will fall under the relevant regulations as stipulated in the Foreign Exchange and Foreign Trade Regulations. Therefore, be sure to follow all procedures and submit all relevant documentation according to any and all rules, regulations and laws that may apply.

Specifications are subject to change without notice for ongoing product modifications and improvements.

© 2013-2015 YASKAWA ELECTRIC CORPORATION. All rights reserved.



\*TOEPC71065607\*

MANUAL NO. TOEP C710656 07C

Published in Japan January 2015 13-7   
14-10-13\_YAI