

HONDA

Power

Equipment

Owner's Manual

GENERATOR

EB3000c

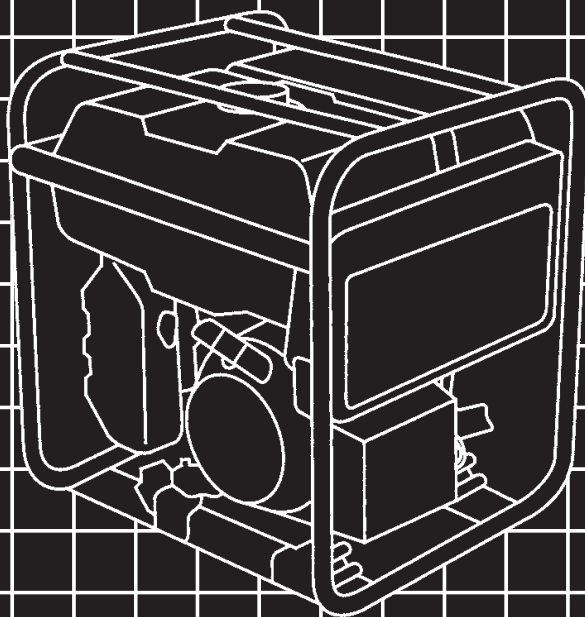



WARNING:



The engine exhaust from this product contains chemicals known to the State of California to cause cancer, birth defects or other reproductive harm.

California Proposition 65

This product contains or emits chemicals known to the state of California to cause cancer, birth defects or other reproductive harm

⚠ WARNING

Exhaust contains poisonous carbon monoxide gas that can build up to dangerous levels in closed areas. Breathing carbon monoxide can cause unconsciousness or death.

Never run the generator in a closed, or even partly closed area where people may be present.

Keep this owner's manual handy so that you can refer to it at any time. This owner's manual is considered a permanent part of the generator and should remain with the generator if resold.

The information and specifications included in this publication were in effect at the time of approval for printing. Honda Motor Co., Ltd. reserves the right, however, to discontinue or change specifications or design at any time without notice and without incurring any obligation whatsoever.

INTRODUCTION

Congratulations on your selection of a Honda generator. We are certain you will be pleased with your purchase of one of the finest generators on the market.

We want to help you get the best results from your new generator and to operate it safely. This manual contains all the information on how to do that; please read it carefully.

As you read this manual, you will find information preceded by a **NOTICE** symbol. That information is intended to help you avoid damage to your generator, other property, or the environment.

We suggest you read the *Distributor's Limited Warranty* to fully understand its coverage and your responsibilities of ownership. The *Distributor's Limited Warranty* is a separate document that should have been given to you by your dealer.

When your generator needs scheduled maintenance, keep in mind that your Honda servicing dealer is specially trained in servicing Honda generators and is supported by the parts and service divisions of American Honda. Your Honda servicing dealer is dedicated to your satisfaction and will be pleased to answer your questions and concerns.

Best Wishes,
Honda Motor Co., Ltd.

A FEW WORDS ABOUT SAFETY

Your safety and the safety of others are very important. And using this generator safely is an important responsibility.

To help you make informed decisions about safety, we have provided operating procedures and other information on labels and in this manual. This information alerts you to potential hazards that could hurt you or others.

Of course, it is not practical or possible to warn you about all the hazards associated with operating or maintaining a generator. You must use your own good judgment.

You will find important safety information in a variety of forms, including:

- **Safety Labels** — on the generator.
- **Safety Messages** — preceded by a safety alert symbol  and one of three signal words, DANGER, WARNING, or CAUTION.

These signal words mean:

 **DANGER**

You **WILL** be KILLED or SERIOUSLY HURT if you don't follow instructions.

 **WARNING**

You **CAN** be KILLED or SERIOUSLY HURT if you don't follow instructions.

 **CAUTION**

You **CAN** be HURT if you don't follow instructions.

- **Safety Headings** — such as *IMPORTANT SAFETY INFORMATION*.
- **Safety Section** — such as *GENERATOR SAFETY*.
- **Instructions** — how to use this generator correctly and safely.

This entire book is filled with important safety information — please read it carefully.

CONTENTS

GENERATOR SAFETY	6
IMPORTANT SAFETY INFORMATION	6
Operator Responsibility	6
Carbon Monoxide Hazards	6
Electric Shock Hazards.....	7
Fire and Burn Hazards	7
Refuel With Care	8
SAFETY LABEL LOCATIONS	9
CONTROLS & FEATURES	10
COMPONENT & CONTROL LOCATIONS	10
CONTROLS	12
Fuel Valve Lever	12
Engine Switch.....	12
Choke Rod	12
Recoil Starter.....	13
AC Circuit Protector	13
AC Circuit Breaker.....	14
Ground Fault Circuit Interrupter (GFCI)	15
FEATURES	16
Ground Terminal	16
Output Indicator.....	17
Oil Alert Indicator	18
Fuel Gauge	19
BEFORE OPERATION	20
ARE YOU READY TO GET STARTED?	20
Knowledge	20
IS YOUR GENERATOR READY TO GO?	20
Check the Engine	21
Check the GFCI.....	21

CONTENTS

OPERATION	22
SAFE OPERATING PRECAUTIONS	22
STARTING THE ENGINE	23
STOPPING THE ENGINE	25
GFCI OPERATION CHECK.....	26
AC OPERATION	28
AC Applications	30
STANDBY POWER.....	31
Connections to a Building’s Electrical System	31
System Ground	31
Special Requirements.....	31
SERVICING YOUR GENERATOR	32
THE IMPORTANCE OF MAINTENANCE	32
MAINTENANCE SAFETY	33
Safety Precautions	33
MAINTENANCE SCHEDULE	34
REFUELING.....	35
FUEL RECOMMENDATIONS.....	36
ENGINE OIL LEVEL CHECK	37
ENGINE OIL CHANGE	38
ENGINE OIL RECOMMENDATIONS	39
AIR CLEANER SERVICE.....	40
FOAM AIR FILTER CLEANING	41
SEDIMENT CUP CLEANING	42
SPARK PLUG SERVICE.....	44
SPARK ARRESTER SERVICE.....	46
STORAGE	47
STORAGE PREPARATION.....	47
Cleaning.....	47
Fuel.....	47
Engine Oil.....	50
STORAGE PRECAUTIONS	51
REMOVAL FROM STORAGE	51

CONTENTS

TRANSPORTING	52
TAKING CARE OF UNEXPECTED PROBLEMS	53
ENGINE WILL NOT START.....	53
ENGINE LACKS POWER	54
NO POWER AT THE AC RECEPTACLES	55
TECHNICAL INFORMATION	56
Serial Number Location	56
Carburetor Modification for High Altitude Operation.....	57
Emission Control System Information.....	58
Air Index	60
Specifications	61
Wiring Diagram	62
CONSUMER INFORMATION	63
Dealer Locator Information	63
Honda Publications.....	63
Customer Service Information.....	64
INITIAL USE INSTRUCTIONS	65
ENGINE OIL	65
FUEL	66
BEFORE OPERATION	67
REGISTRATION.....	67
INDEX	68
QUICK REFERENCE INFORMATION	Inside back cover

GENERATOR SAFETY

IMPORTANT SAFETY INFORMATION

Honda generators are designed for use with electrical equipment that has suitable power requirements. Other uses can result in injury to the operator or damage to the generator and other property.

Most injuries or property damage can be prevented if you follow all instructions in this manual and on the generator. The most common hazards are discussed below, along with the best way to protect yourself and others.

Operator Responsibility

- Know how to stop the generator quickly in case of emergency.
- Understand the use of all generator controls, output receptacles, and connections.
- Be sure that anyone who operates the generator receives proper instruction. Do not let children operate the generator without parental supervision.

Carbon Monoxide Hazards

A generator's exhaust contains toxic carbon monoxide, which you cannot see or smell. Breathing carbon monoxide can KILL YOU IN MINUTES. To avoid carbon monoxide poisoning, follow these instructions when operating a generator:

- Only run a generator OUTSIDE, far away from windows, doors, and vents.
- Never operate a generator inside a house, garage, basement, crawl space, or any enclosed or partially enclosed space.
- Never operate a generator near open doors or windows.
- Get fresh air and seek medical attention immediately if you suspect you have inhaled carbon monoxide.

Early symptoms of carbon monoxide exposure include headache, fatigue, shortness of breath, nausea, and dizziness. Continued exposure to carbon monoxide can cause loss of muscular coordination, loss of consciousness, and then death.

To alert you to potentially dangerous levels of carbon monoxide coming from a generator operating outside or from other sources, install battery operated carbon monoxide alarms or plug-in carbon monoxide alarms with battery back-up on every level of the home and outside sleeping areas, according to the manufacturer's instructions.

Electric Shock Hazards

- The generator produces enough electric power to cause a serious shock or electrocution if misused.
- Using a generator or electrical appliance in wet conditions, such as rain or snow, or near a pool or sprinkler system, or when your hands are wet, could result in electrocution. Keep the generator dry.
- If the generator is stored outdoors, unprotected from the weather, check the Ground Fault Circuit Interrupter (GFCI) receptacle and all other electrical components on the control panel before each use. Moisture or ice can cause a malfunction or short circuit in electrical components that could result in electrocution.

Fire and Burn Hazards

- The exhaust system gets hot enough to ignite some materials.
 - Keep the generator at least 3 feet (1 meter) away from buildings and other equipment during operation.
 - Do not enclose the generator in any structure.
 - Keep flammable materials away from the generator.
- The muffler becomes very hot during operation and remains hot for a while after stopping the engine. Be careful not to touch the muffler while it is hot. Let the engine cool before storing the generator indoors.

GENERATOR SAFETY

Refuel With Care

Gasoline is extremely flammable, and gasoline vapor can explode.

Allow the engine to cool if the generator has been in operation.

Refuel only outdoors in a well-ventilated area with the engine off.

Do not refuel during operation.

Do not overfill the fuel tank.

Never smoke near gasoline, and keep other flames and sparks away.



Always store gasoline in an approved container.





Make sure that any spilled fuel has been wiped up before starting the engine.

SAFETY LABEL LOCATIONS

These labels warn you of potential hazards that can cause serious injury. Read them carefully. If a label comes off or becomes hard to read, contact your Honda servicing dealer for a replacement.

⚠ WARNING	
<p>Operation of This Equipment May Create Sparks That Can Start Fires Around Dry Vegetation. A Spark Arrestor May be Required. The Operator Should Contact Local Fire Agencies For Laws or Regulations Relating to Fire Prevention Requirements.</p> <p><small>Per California Public Resources Code 4442.6</small></p>	
⚠ CAUTION	
	<p>A hot exhaust system can cause serious burns.</p> <p>■ Avoid contact if the engine has been running.</p>

⚠ DANGER	
<p>Using a generator indoors CAN KILL YOU IN MINUTES. Generator exhaust contains carbon monoxide. This is a poison you cannot see or smell.</p>	
	
<p>NEVER use inside a home or garage, EVEN IF doors and windows are open.</p>	<p>Only use OUTSIDE and far away from windows, doors, and vents.</p>

⚠ WARNING	
	<p>Gasoline is highly flammable and explosive. You could be burned or seriously injured if the gasoline is ignited.</p> <ul style="list-style-type: none"> ■ Before refueling, stop the engine and keep heat, sparks, and flame away. ■ Handle fuel only outdoors. ■ Do not fill the fuel tank above the upper limit line. ■ Wipe up spills immediately.
	<p>Exhaust contains poisonous carbon monoxide gas that can build up to dangerous levels in closed areas. Breathing carbon monoxide can cause unconsciousness or death.</p> <ul style="list-style-type: none"> ■ Never run the generator in a closed, or even partly closed area where people may be present.
	<p>Improper connections to a building can allow electrical current to backfeed into utility lines, creating an electrocution hazard.</p> <ul style="list-style-type: none"> ■ Connections to a building must isolate generator power from utility power and comply with all applicable laws and electrical codes.
	<p>The generator is a potential source of electrical shock if not kept dry or cover is removed.</p> <ul style="list-style-type: none"> ■ Do not expose the generator to moisture, rain or snow. ■ Do not operate the generator with wet hands. ■ Do not remove covers when engine is running.
	<p>Read owner's manual carefully before operation.</p>

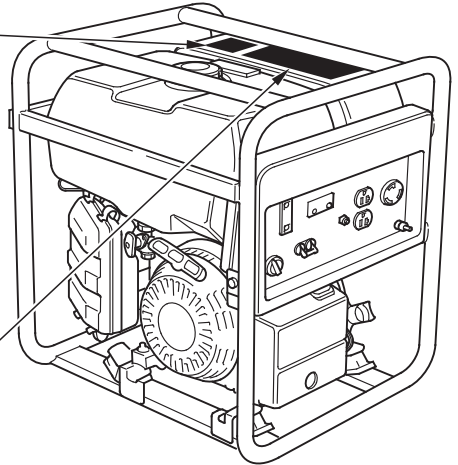

CONTROLS & FEATURES

COMPONENT & CONTROL LOCATIONS

Use the two illustrations on these pages to locate and identify the most frequently used controls.

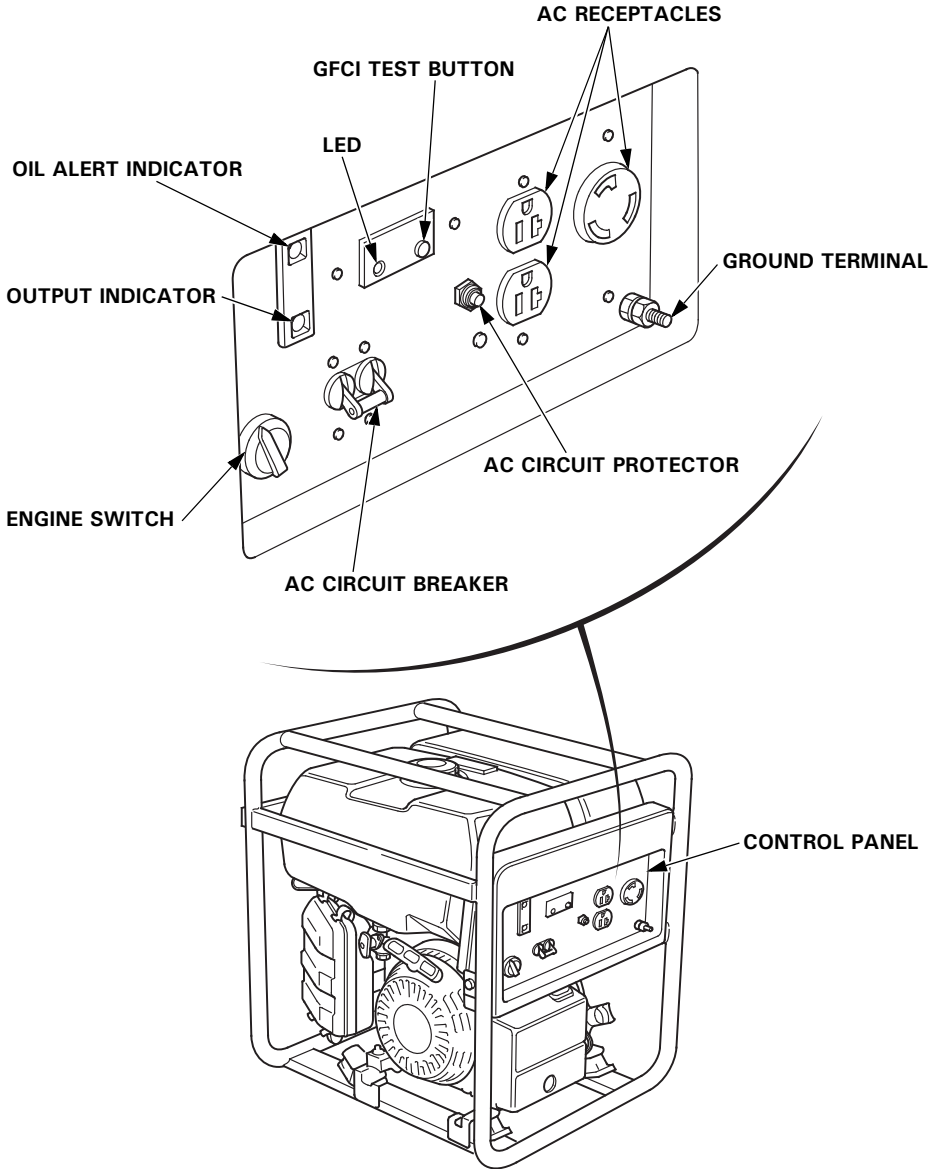

CONTROL & FEATURES

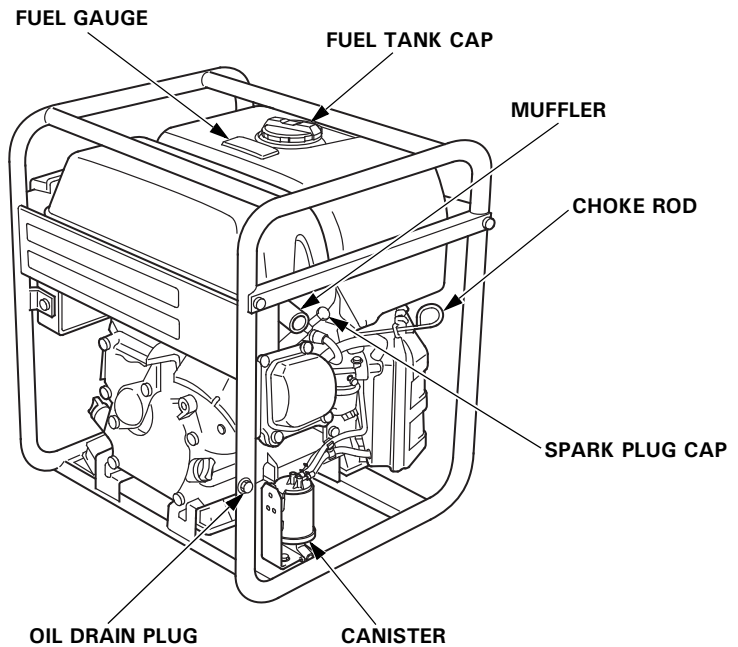
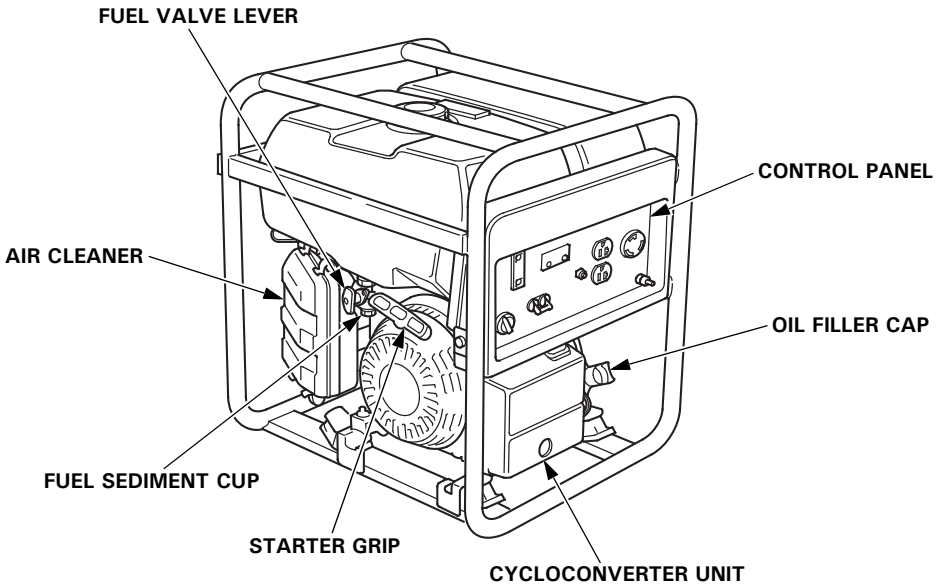

CONTROL & FEATURES

CONTROLS

Fuel Valve Lever

The fuel valve lever is located between the fuel tank and carburetor.

The fuel valve lever must be in the ON position for the engine to run.

After stopping the engine, turn the fuel valve lever to the OFF position.

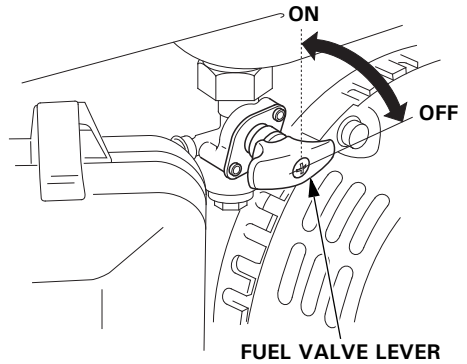

Engine Switch

The engine switch controls the ignition system.

OFF – Stops the engine.

ON – Running position, and for starting with the recoil starter.

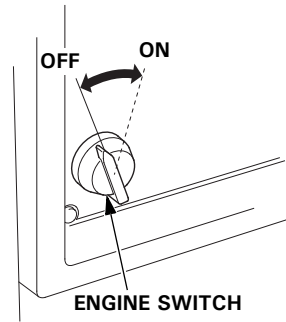

Choke Rod

The choke rod opens and closes the choke valve in the carburetor.

Pulling the choke rod to the CLOSED position enriches the fuel mixture for starting a cold engine.

Pushing the choke rod to the OPEN position provides the correct fuel mixture for operation after starting, and for restarting a warm engine.

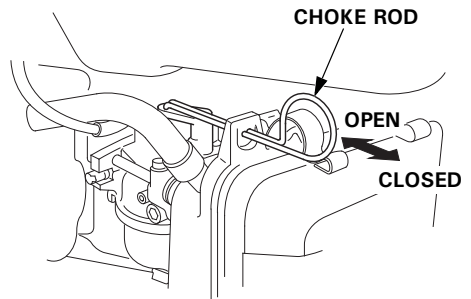

Recoil Starter

Pulling the starter grip operates the recoil starter to crank the engine for starting.

NOTICE

- *Do not allow the starter grip to snap back against the engine. Return it gently to prevent damage to the starter.*
- *Do not let the starter rope rub against the generator body, or the rope will wear out prematurely.*

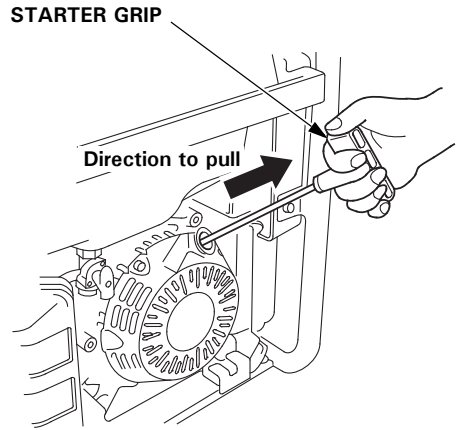

AC Circuit Protector

The AC circuit protector will automatically switch to OFF if there is a short circuit or a significant overload of the generator at each receptacle. If an AC circuit protector switches OFF automatically, check that the appliance is working properly and does not exceed the rated load capacity of the circuit before resetting the AC circuit protector ON.

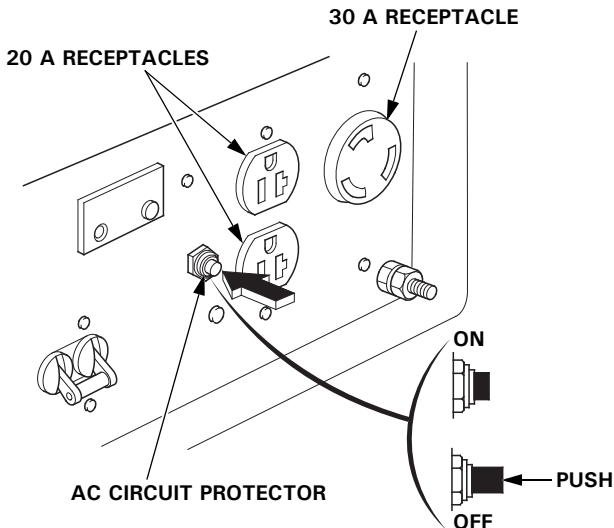

CONTROL & FEATURES

AC Circuit Breaker

The AC circuit breaker will automatically switch OFF if there is a short circuit or a significant overload at the receptacles, or if the ground fault circuit interrupter (GFCI) detects a ground fault current.

The AC circuit breaker may be used to switch the generator power ON or OFF.

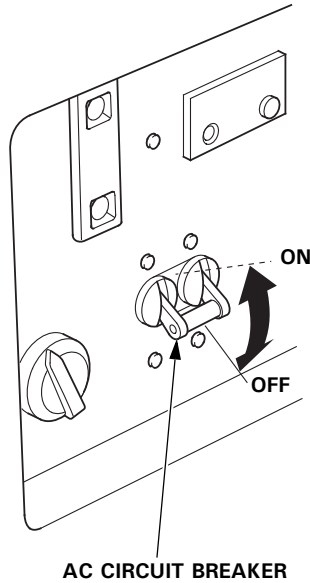

Ground Fault Circuit Interrupter (GFCI)

All receptacles on the generator are protected by a Ground Fault Circuit Interrupter (GFCI) for protection against the shock hazard of ground fault current. The GFCI has a TEST button and is connected to the AC circuit breaker.

An example of ground-fault current is the current that would flow through a person who is using an appliance with faulty insulation and, at the same time, is in contact with an electrical ground such as a plumbing fixture, wet floor, or earth. The GFCI will protect against current flowing through that person.

The GFCI will not protect against short circuits or overloads. The AC circuit breaker and AC circuit protector provide that protection (see pages 13 and 14).

GFCIs can be expected to interrupt power supply if there are ground faults or stray current imposed on the wiring by other electrical devices, wiring, or equipment. As a result there is a risk of interruption if used with critical systems such as life support equipment, so users should first carefully consider whether it is appropriate to use this portable generator to power such equipment.

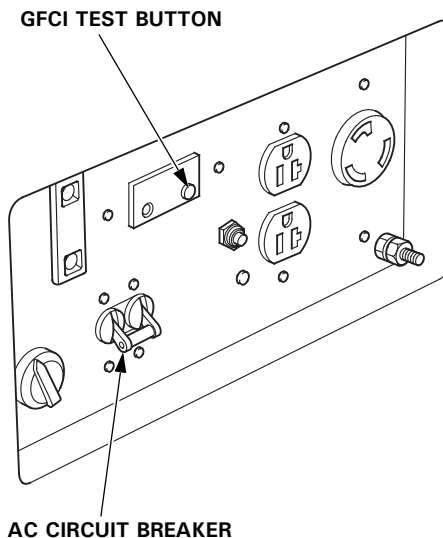

CONTROL & FEATURES

FEATURES

Ground Terminal

The ground terminal is connected to the frame of the generator, the metal non-current-carrying parts of the generator, and the ground terminals of each receptacle.

Before using the ground terminal, consult a qualified electrician, electrical inspector, or local agency having jurisdiction for local codes or ordinances that apply to the intended use of the generator.

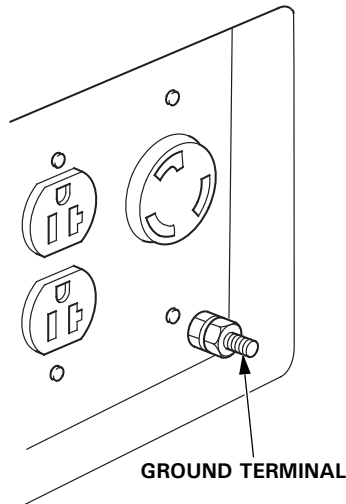

Output Indicator

The output indicator (green) will remain ON during normal operating conditions.

If there is a short circuit in a connected appliance or if the CycloConverter™ unit overheats, the output indicator (green) blinks and current to the connected appliance(s) will shut off. When this happens, disconnect the appliance(s) and stop the engine to investigate the problem.

Determine if the cause is a short circuit in a connected appliance or an overheated CycloConverter unit. Correct the problem and restart the engine.

If the output indicator (green) blinks again, consult your Honda generator dealer.

The output indicator (green) may blink at intervals of 2.5 seconds, depending on connected appliance(s) to the AC receptacles. It indicates that the output voltage has dropped slightly. It does not matter as long as the connected appliance(s) work properly.

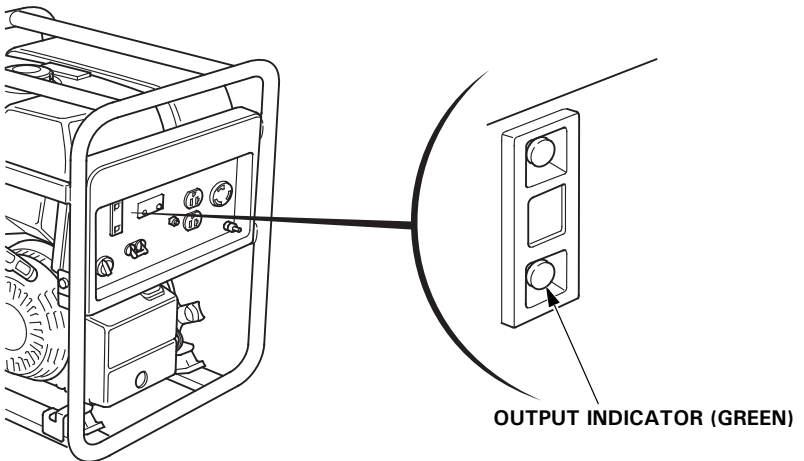

CONTROL & FEATURES

Oil Alert[®] Indicator

The Oil Alert[®] system is designed to prevent engine damage caused by an insufficient amount of oil in the crankcase. Before the oil level in the crankcase can fall below a safe limit, the Oil Alert indicator comes on, and the Oil Alert system automatically will stop the engine (the engine switch will remain in the ON position).

If the engine stops or the Oil Alert indicator comes on when you pull the starter grip, check the engine oil level (see page 37) before troubleshooting in other areas.

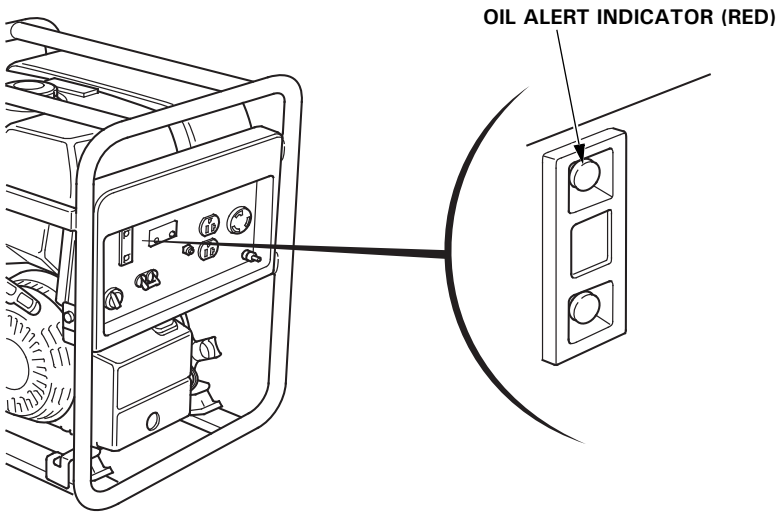

Fuel Gauge

The fuel gauge is a mechanical device that measures the fuel level in the tank. The red indicator in the window will reference the level in relation to full or empty. To provide increased operating time, start with a full tank before beginning operation. Check the fuel level with the generator on a level surface. Always refuel with the engine OFF and cool.

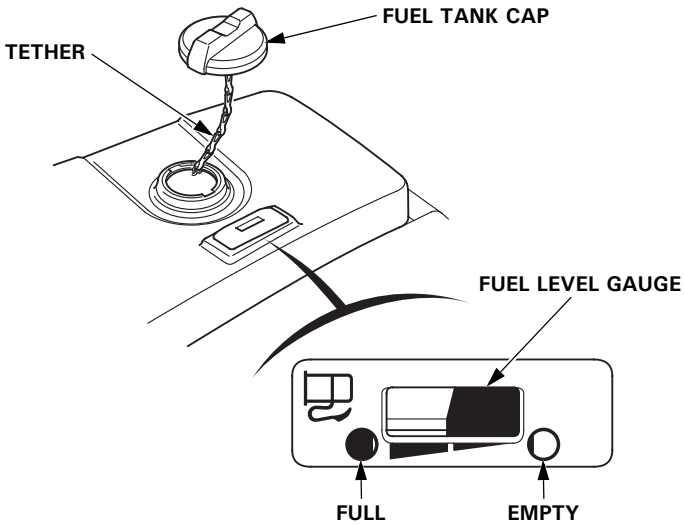

BEFORE OPERATION

ARE YOU READY TO GET STARTED?

Your safety is your responsibility. A little time spent in preparation will significantly reduce your risk of injury.

Knowledge

Read and understand this manual. Know what the controls do and how to operate them.

Familiarize yourself with the generator and its operation before you begin using it. Know how to quickly shut off the generator in case of an emergency.

If the generator is being used to power appliances, be sure that they do not exceed the generator's load rating (see page 30).

IS YOUR GENERATOR READY TO GO?

For your safety, to ensure compliance with environmental regulations, and to maximize the service life of your equipment, it is very important to take a few moments before you operate the generator to check its condition. Be sure to take care of any problem you find, or have your servicing dealer correct it, before you operate the generator.

WARNING

Improperly maintaining this generator, or failing to correct a problem before operation, could cause a malfunction in which you could be seriously injured.

Always perform a pre-operation inspection before each operation, and correct any problem.

To prevent a possible fire, keep the generator at least 3 feet (1 meter) away from building walls and other equipment during operation. Do not place flammable objects close to the engine.

Before beginning your pre-operation checks, be sure the generator is on a level surface and the engine switch is in the OFF position.

Check the Engine

- Before each use, look around and underneath the engine for signs of oil or gasoline leaks.
- Check the oil level (see page 37). A low oil level will cause the Oil Alert system to shut down the engine.
- Check the air filter (see page 40). A dirty air filter will restrict air flow to the carburetor, reducing engine and generator performance.
- Check the fuel level (see page 35). Starting with a full tank will help to eliminate or reduce operating interruptions for refueling.

Check the GFCI

Check the GFCI operation (see page 26) after starting the engine.

OPERATION

SAFE OPERATING PRECAUTIONS

Before operating the generator for the first time, review chapters *GENERATOR SAFETY* (see page 6) and *BEFORE OPERATION* (see page 20).

For your safety, do not operate the generator in an enclosed area such as a garage. Your generator's exhaust contains poisonous carbon monoxide gas that can collect rapidly in an enclosed area and cause illness or death.

⚠ WARNING

Exhaust contains poisonous carbon monoxide gas that can build up to dangerous levels in closed areas. Breathing carbon monoxide can cause unconsciousness or death.

Never run the generator in a closed, or even partly closed area where people may be present.

Before connecting an AC appliance or power cord to the generator:

- Use grounded 3-prong extension cords, tools, and appliances, or double-insulated tools and appliances.
- Inspect cords and plugs, and replace if damaged.
- Do not use cord lengths greater than 164 feet (50 meters), and do not use multiple tools and appliances with built-in noise filters. Such use may activate the GFCI and trip the circuit breaker.
- Make sure that the appliance is in good working order. Faulty appliances or power cords can create a potential for electric shock.
- Make sure the electrical rating of the tool or appliance does not exceed the rated power of the generator or the receptacle being used.
- Operate the generator at least 3 feet (1 meter) away from buildings and other equipment.
- Do not operate the generator in an enclosed structure.
- Do not place flammable objects close to the engine.

STARTING THE ENGINE

Refer to *SAFE OPERATING PRECAUTIONS* on page 22.

1. Make sure that the AC circuit breaker is in the OFF position. The generator may be hard to start if a load is connected.

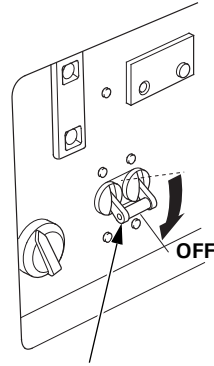

AC CIRCUIT BREAKER

2. Turn the fuel valve lever to the ON position.

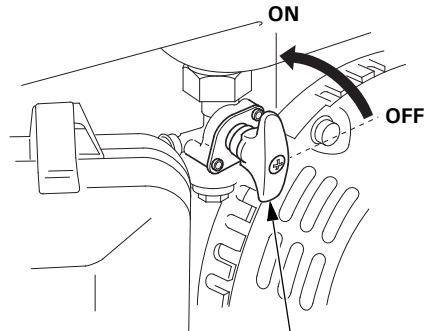

FUEL VALVE LEVER

3. Pull the choke rod to the CLOSED position to start a cold engine. Leave the choke rod in the OPEN position to start a warm engine.

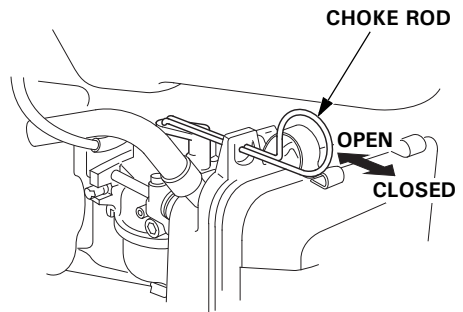

OPERATION

- Turn the engine switch to the ON position.

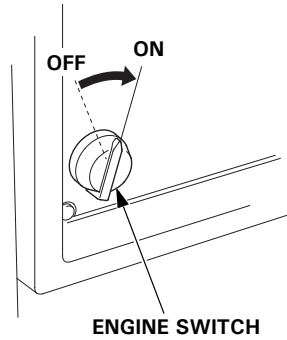

- Pull the starter grip lightly until resistance is felt, then pull briskly.

NOTICE

- Do not allow the starter grip to snap back against the engine. Return it gently to prevent damage to the starter.*
 - Do not let the starter rope rub against the generator body, or the rope will wear out prematurely.*
- If the choke rod was moved to the CLOSED position to start the engine, gradually push it to the OPEN position as the engine warms up.

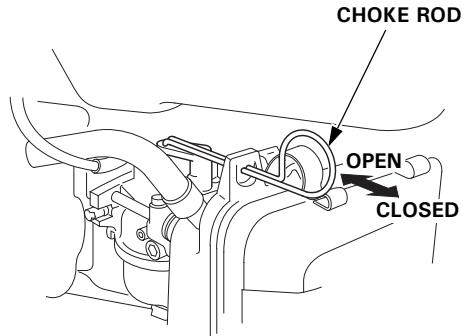
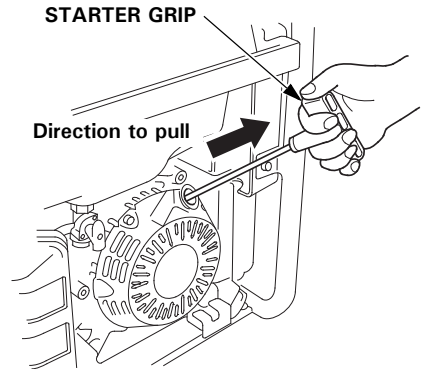

STOPPING THE ENGINE

To stop the engine in an emergency, simply turn the engine switch to the OFF position. Under normal conditions, use the following procedure.

1. Turn off or disconnect all appliances that are connected to the generator.
2. Switch the AC circuit breaker to the OFF position.

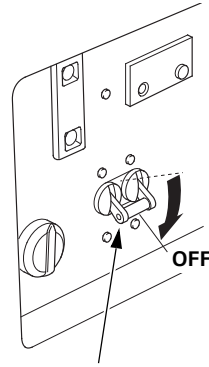

AC CIRCUIT BREAKER

3. Turn the engine switch to the OFF position.

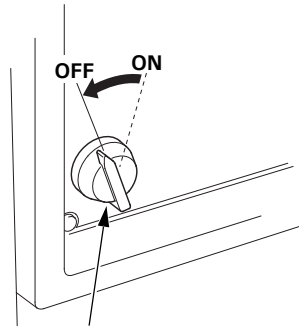

ENGINE SWITCH

4. Turn the fuel valve lever to the OFF position.

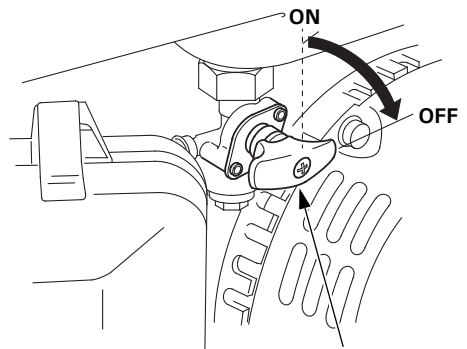

FUEL VALVE LEVER

OPERATION

GFCI OPERATION CHECK

Always check GFCI operation before using the generator.

⚠ WARNING

A faulty GFCI can cause electric shock which can seriously injure or kill you.

Always perform the GFCI inspection before using the generator. If the GFCI fails the test, the generator must be repaired by an authorized Honda servicing dealer before use.

1. Unplug all tools and appliances from the generator.
2. Start the engine (see page 23).
3. Turn the AC circuit breaker to the ON position.
4. Press the GFCI TEST button. The LED comes on, and the AC circuit breaker switches to the OFF position.

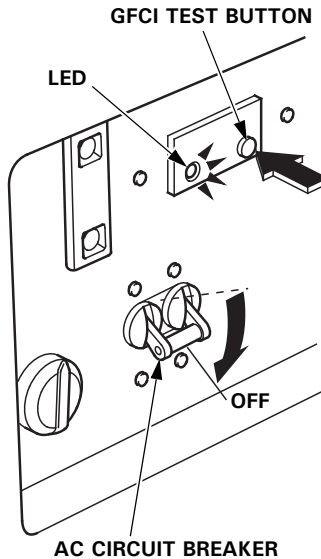

5. When you switch the AC circuit breaker to the ON position, LED will turn off.

If the GFCI and AC circuit breaker do not function as described, take the generator to an authorized Honda generator dealer for repair.

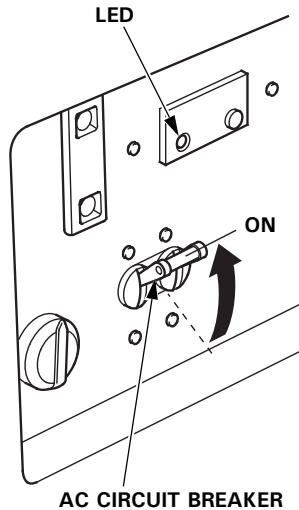

During generator use, if the AC circuit breaker trips, this usually indicates a faulty power tool, appliance, or cord.

If that occurs, perform test steps 1 through 5 to verify that the GFCI and AC circuit breaker are in proper working order. If the GFCI and AC circuit breaker do test correctly, then the fault is likely to be in the power tool, appliance, or cord. Repair or replace the faulty power tool, appliance, or cord before further use.

OPERATION

AC OPERATION

If an appliance begins to operate abnormally, becomes sluggish, or stops suddenly, turn it off immediately. Disconnect the appliance, and determine whether the problem is in the appliance or the rated load capacity of the generator has been exceeded.

NOTICE

Substantial overloading may damage the generator. Marginal overloading may shorten the service life of the generator.

1. Start the engine (see page 23) and make sure the output indicator (green) comes on.
2. Switch ON the AC circuit breaker.
3. Plug in the appliance.

Most motorized appliances require more than their rated wattage for startup.

Do not exceed the current limit specified for any one receptacle. If an overloaded circuit causes the AC circuit breaker to switch OFF, reduce the electrical load on the circuit, wait a few minutes and then reset the AC circuit breaker.

OUTPUT INDICATOR (GREEN)

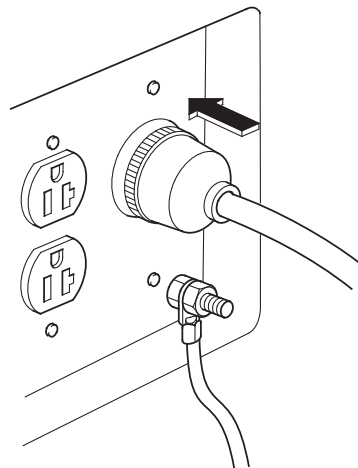
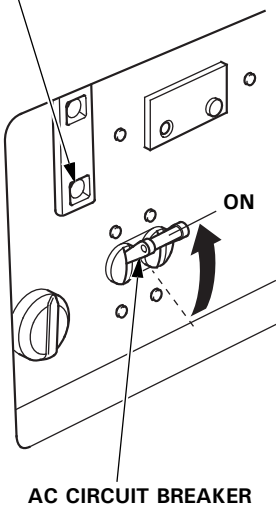

If there is a short circuit in a connected appliance, or if the inverter is overheated, the output indicator (green) will blink and current to the connected appliance(s) will shut off. Stop the engine and investigate the problem.

Determine if the cause is a short circuit in a connected appliance, or an overheated inverter. Correct the problem and restart the generator.

Before connecting an appliance to the generator, make sure that it is in good order and that its electrical rating does not exceed that of the generator. Then start the generator and connect the appliance power cord.

If the output indicator (green) blinks again, consult your Honda generator dealer.

OPERATION

AC Applications

Before connecting an appliance or power cord to the generator:

- Make sure that it is in good working order. A faulty appliance or power cord can create a potential for electrical shock.
- If an appliance begins to operate abnormally, becomes sluggish, or stops suddenly, turn it off immediately. Disconnect the appliance, and determine whether the problem is the appliance or the rated load capacity of the generator has been exceeded.

Most appliance motors require more than their rated wattage for startup.

Make sure the electrical rating of the tool or appliance does not exceed the maximum power rating of the generator.

Maximum power is:

3.0 kVA

For continuous operation, do not exceed the rated power.

Rated power is:

2.6 kVA

In either case, the total power requirements (VA) of all appliances connected must be considered. Appliance and power tool manufacturers usually list rating information near the model number or serial number.

NOTICE

Substantial overloading will open the circuit breaker. Slightly overloading the generator may not switch the circuit breaker OFF, but will shorten the service life of the generator.

STANDBY POWER

Connections to a Building's Electrical System

Do not connect an EB3000c generator to a home or building's electrical system.

The Honda EB3000c generator is designed for construction job site use and cannot be connected to a building's electrical system. This generator has the neutral bonded to ground to comply with OSHA job site temporary power regulation. Building main breaker boxes also have the neutral bonded to ground, so if an EB3000c generator is connected to a home or building electrical system, the GFCI relay will trip the generator's main circuit breaker.

System Ground

This generator has a system ground that connects generator frame components to ground terminals in the AC output receptacles. The system ground is connected to the AC neutral wire.

Special Requirements

There may be Federal or State Occupational Safety and Health Administration (OSHA) regulations, local codes, or ordinances that apply to the intended use of the generator. Please consult a qualified electrician, electrical inspector, or the local agency having jurisdiction.

- In some areas, generators are required to be registered with local utility companies.
- If the generator is used at a construction site, there may be additional regulations that must be observed.

SERVICING YOUR GENERATOR

THE IMPORTANCE OF MAINTENANCE

Good maintenance is essential for safe, economical, and trouble free operation. It will also help reduce air pollution.

To help you properly care for your generator, the following pages include a maintenance schedule, routine inspection procedures, and simple maintenance procedures using basic hand tools. Other service tasks that are more difficult or require special tools are best handled by professionals and are normally performed by a Honda technician or other qualified mechanic.

The maintenance schedule applies to normal operating conditions. If you operate your generator under unusual conditions, such as sustained high-load or high-temperature operation, or use it in dusty conditions, consult your servicing dealer for recommendations applicable to your individual needs and use.

⚠ WARNING

Improper maintenance, or failure to correct a problem before operation, can cause a malfunction in which you can be seriously hurt or killed.

Always follow the inspection and maintenance recommendations and schedules in this owner's manual.

Remember that an authorized Honda servicing dealer knows your generator best and is fully equipped to maintain and repair it.

To ensure the best quality and reliability, use only new, Honda Genuine parts or their equivalents for repair and replacement.

Maintenance, replacement, or repair of the emission control devices and systems may be performed by any engine repair establishment or individual, using parts that are "certified" to EPA standards.

MAINTENANCE SAFETY

Some of the most important safety precautions follow. However, we cannot warn you of every conceivable hazard that can arise in performing maintenance. Only you can decide whether or not you should perform a given task.

⚠ WARNING

Failure to properly follow maintenance instructions and precautions can cause you to be seriously hurt or killed.

Always follow the procedures and precautions in the owner's manual.

Safety Precautions

Make sure the engine is off before you begin any maintenance or repairs. This will eliminate several potential hazards:

- **Carbon monoxide poisoning from engine exhaust.**
Be sure there is adequate ventilation whenever you operate the engine.
- **Burns from hot parts.**
Let the engine and exhaust system cool before touching.
- **Injury from moving parts.**
Do not run the engine unless instructed to do so.
- Read the instructions before you begin, and make sure you have the tools and skills required.
- To reduce the possibility of fire or explosion, be careful when working around gasoline. Use only a non-flammable solvent, not gasoline, to clean parts. Keep cigarettes, sparks, and flames away from all fuel-related parts.

SERVICING YOUR GENERATOR

MAINTENANCE SCHEDULE

REGULAR SERVICE PERIOD (3) ITEM Perform at every indicated month or operating hour interval, whichever comes first.		Each use	First month or 20 Hrs.	Every 3 months or 50 Hrs.	Every 6 months or 100 Hrs.	Every year or 300 Hrs.	Page
Engine oil	Check level	o					37
	Change		o		o		38
Air cleaner	Check	o					40
	Clean			o (1)			41
	Replace					o (*)	40
GFCI operation	Check	o					26
Canister	Check	Every 2 years (Replace if necessary) (2)					—
Purge tube	Check	Every 2 years (Replace if necessary) (2)					—
Charge tube	Check	Every 2 years (Replace if necessary) (2)					—
Sediment cup	Clean				o		42
Spark plug	Check-adjust				o		44
	Replace					o	44
Spark arrester	Clean				o		46
Valve clearance	Check-adjust					o (2)	—
Combustion chamber	Clean	After every 500 Hrs. (2)					—
Fuel tank and filter	Clean					o (2)	—
Fuel tube	Check	Every 2 years (Replace if necessary) (2)					—

NOTE: (*) Replace paper element type only.

- (1) Service more frequently when used in dusty areas.
- (2) These items should be serviced by your servicing dealer, unless you have the proper tools and are mechanically proficient. Refer to the Honda shop manual for service procedures.
See "Honda Publications" on page 63 for ordering information.
- (3) For commercial use, log hours of operation to determine proper maintenance intervals.

Failure to follow this maintenance schedule could result in non-warrantable failures.

SERVICING YOUR GENERATOR

REFUELING

With the engine stopped, check the fuel level gauge. Refill the fuel tank if the fuel level is low.

⚠ WARNING

Gasoline is highly flammable and explosive.

You can be burned or seriously injured when handling fuel.

- Stop the engine and keep heat, sparks, and flame away.
- Handle fuel only outdoors.
- Wipe up spills immediately.

NOTICE

Fuel can damage paint and plastic. Be careful not to spill fuel when filling your fuel tank. Damage caused by spilled fuel is not covered under warranty.

Refuel in a well-ventilated area before starting the engine. If the engine has been running, allow it to cool. Refuel carefully to avoid spilling fuel. Do not fill the fuel tank above the upper level mark.

Never refuel the engine inside a building where gasoline fumes may reach flames or sparks. Keep gasoline away from appliance pilot lights, barbecues, electric appliances, power tools, etc.

Spilled fuel is not only a fire hazard, it causes environmental damage. Wipe up spills immediately.

SERVICING YOUR GENERATOR

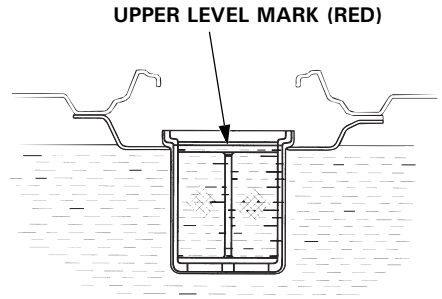
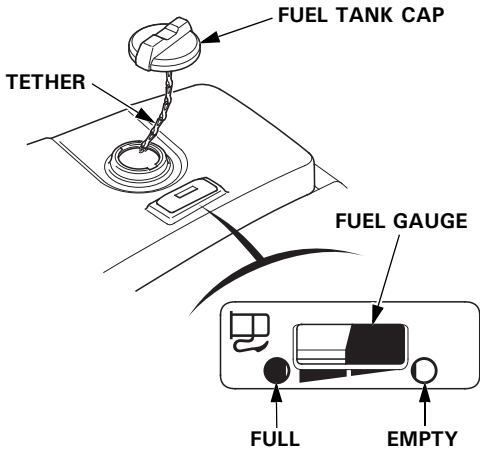

After refueling, reinstall the fuel tank cap securely.

FUEL RECOMMENDATIONS

This engine is certified to operate on regular unleaded gasoline with a pump octane rating of 86 or higher.

Never use stale or contaminated gasoline or an oil/gasoline mixture. Avoid getting dirt or water in the fuel tank.

You may use regular unleaded gasoline containing no more than 10% ethanol (E10) or 5% methanol by volume. In addition, methanol must contain cosolvents and corrosion inhibitors.

Use of fuels with content of ethanol or methanol greater than shown above may cause starting and/or performance problems. It may also damage metal, rubber, and plastic parts of the fuel system.

Engine damage or performance problems that result from using a fuel with percentages of ethanol or methanol greater than shown above are not covered under warranty.

If your equipment will be used on an infrequent or intermittent basis, please refer to the fuel section of the *STORAGE* chapter (see page 47) for additional information regarding fuel deterioration.

SERVICING YOUR GENERATOR

ENGINE OIL LEVEL CHECK

Check the engine oil level with the generator on a level surface and the engine stopped.

1. Remove the oil filler cap.
2. Check the oil level. If it is below the upper limit, fill with the recommended oil to the upper limit of the oil filler neck (see page 39).
3. Reinstall the oil filler cap securely.

OIL FILLER NECK

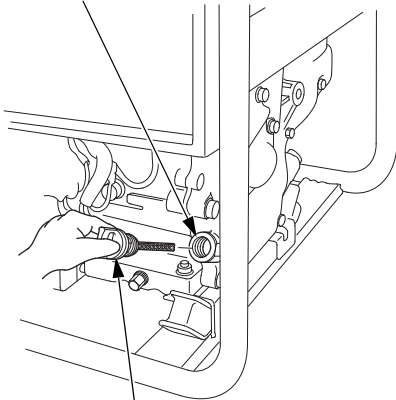

OIL FILLER CAP

UPPER LIMIT

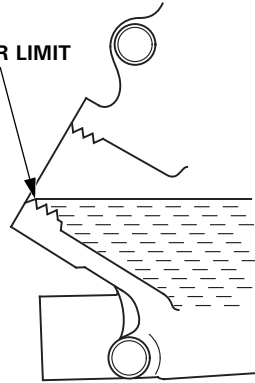

The Oil Alert system will automatically stop the engine before the oil level falls below safe limits. However, to avoid the inconvenience of an unexpected shutdown, check the oil level regularly.

SERVICING YOUR GENERATOR

ENGINE OIL CHANGE

Drain the oil while the engine is warm to assure rapid and complete draining.

1. Place a suitable container below the engine to catch the used oil, and then remove the oil filler cap, drain plug, and sealing washer.
2. Allow the used oil to drain completely, and then reinstall the drain plug and a new sealing washer. Tighten the plug securely.

NOTICE

Improper disposal of engine oil can be harmful to the environment. If you change your own oil, please dispose of the used oil properly. Put it in a sealed container, and take it to a recycling center. Do not discard it in a trash bin, dump it on the ground, or pour it down the drain.

3. With the generator in a level position, fill with the recommended oil to the upper limit of the oil filler neck (see page 39).

Maximum oil capacity: 18 oz (0.55 L)

4. Reinstall the oil filler cap securely.

Wash your hands with soap and water after handling used oil.

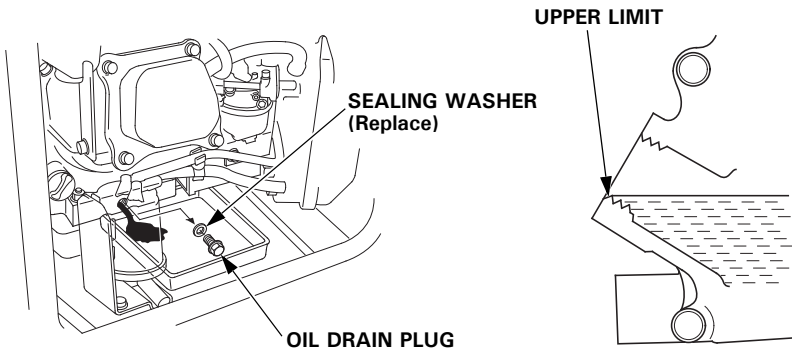

SERVICING YOUR GENERATOR

ENGINE OIL RECOMMENDATIONS

Oil is a major factor affecting performance and service life. Use 4-stroke automotive detergent oil.

SAE 10W-30 is recommended for general use. Other viscosities shown in the chart may be used when the average temperature in your area is within the recommended range.

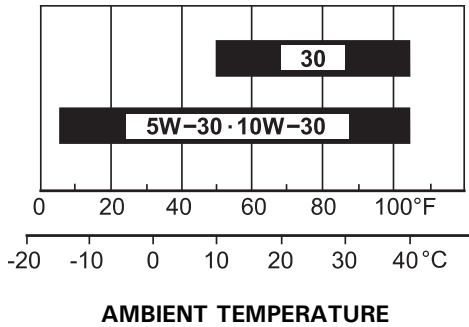

The SAE oil viscosity and service classification are in the API label on the oil container. Honda recommends that you use API service category SJ or later (or equivalent) oil.

SERVICING YOUR GENERATOR

AIR CLEANER SERVICE

1. Unsnap the air cleaner cover clips, and remove the air cleaner cover.

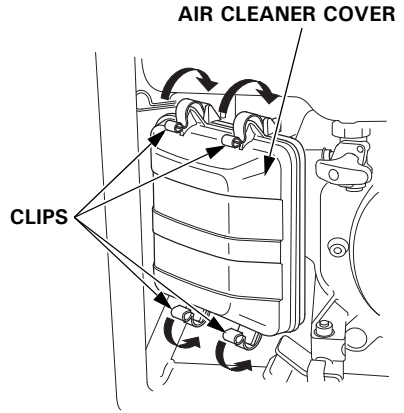

2. Check the foam air filter and paper air filter to be sure they are clean and in good condition. If the foam air filter is dirty, clean it as described on page 41. If the paper air filter is dirty, replace it with new one. Do not clean the paper air filter.

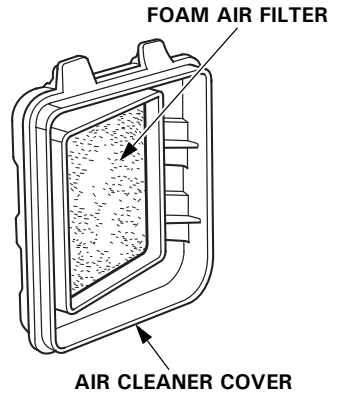

3. Reinstall the air cleaner cover.

NOTICE

Operating the engine without an air filter or with a damaged air filter will allow dirt to enter the engine, causing rapid engine wear. This type of damage is not covered by the Distributor's Limited Warranty.

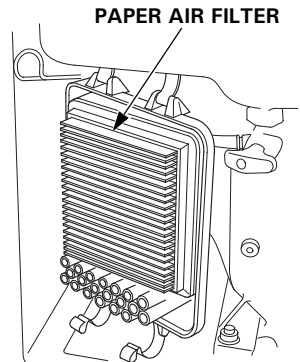

SERVICING YOUR GENERATOR

FOAM AIR FILTER CLEANING

A dirty foam air filter will restrict air flow to the carburetor, reducing engine performance. If you operate the generator in very dusty areas, clean the foam air filter more frequently than specified in the Maintenance Schedule.

1. Wash the foam air filter in a solution of household detergent and warm water, then rinse thoroughly, or wash in non-flammable or high flash point solvent. Allow the foam air filter to dry thoroughly.
2. Soak the foam air filter in clean engine oil and squeeze out the excess oil. The engine will smoke during initial startup if too much oil is left in the foam air filter.

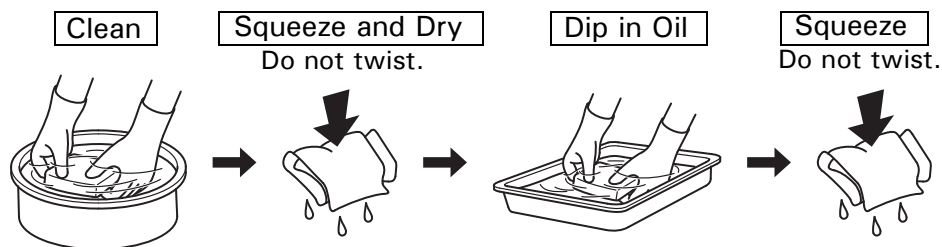

3. Wipe dirt from the air cleaner housing and cover using a moist rag. Be careful to prevent dirt from entering the air duct that leads to the carburetor.

SERVICING YOUR GENERATOR

SEDIMENT CUP CLEANING

The sediment cup prevents water that may be in the fuel tank from entering the carburetor. If the engine has not been run for a long time, the sediment cup should be cleaned.

1. Turn the engine switch to the OFF position.
2. Turn the fuel valve lever to the OFF position.
3. Unscrew the sediment cup.

⚠ WARNING

Gasoline is highly flammable and explosive.

You can be burned or seriously injured when handling fuel.

- Stop the engine and keep heat, sparks, and flame away.
- Handle fuel only outdoors.
- Wipe up spills immediately.

SERVICING YOUR GENERATOR

4. Clean the sediment cup in non-flammable or high flash point solvent.
5. Install the sediment cup and a new O-ring.
6. Turn the fuel valve to the ON position and check for leaks.

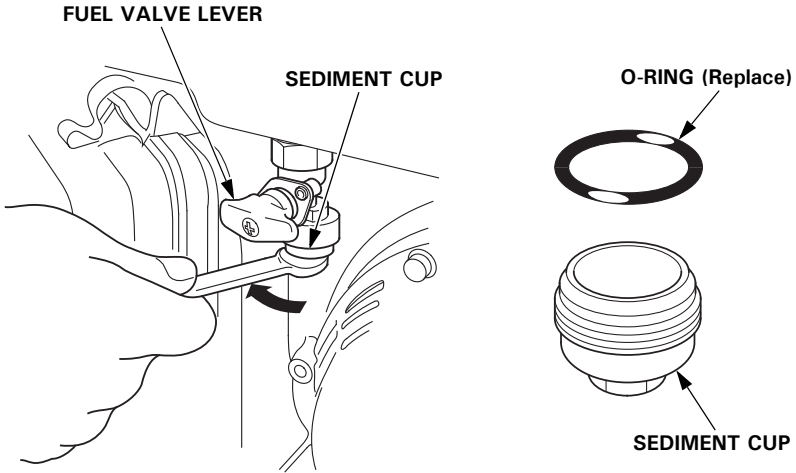

SERVICING YOUR GENERATOR

SPARK PLUG SERVICE

In order to service the spark plug, you will need a spark plug wrench (commercially available).

Recommended spark plugs: BPR6ES (NGK)
W20EPR-U (DENSO)

To ensure proper engine operation, the spark plug must be properly gapped and free of deposits.

NOTICE

An incorrect spark plug can cause engine damage.

If the engine is hot, allow it to cool before servicing the spark plug.

1. Remove the spark plug cap.
2. Clean any dirt from around the spark plug base.
3. Use a spark plug wrench to remove the spark plug.

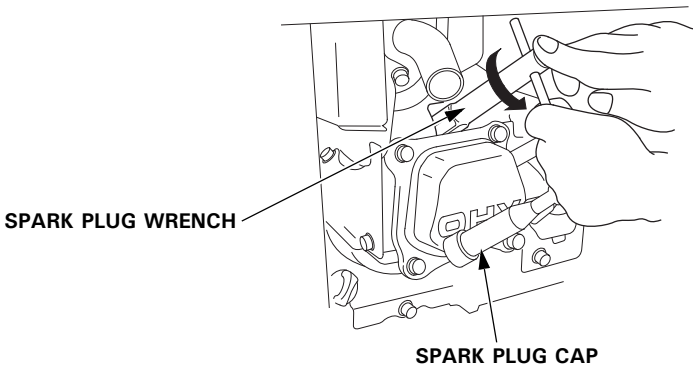

SERVICING YOUR GENERATOR

4. Visually inspect the spark plug. Replace it if the electrodes are worn or if the insulator is cracked, chipped, or fouled.
5. Measure the spark plug electrode gap with a wire-type feeler gauge. Correct the gap, if necessary, by carefully bending the side electrode. The gap should be:
0.028–0.031 in (0.7–0.8 mm)

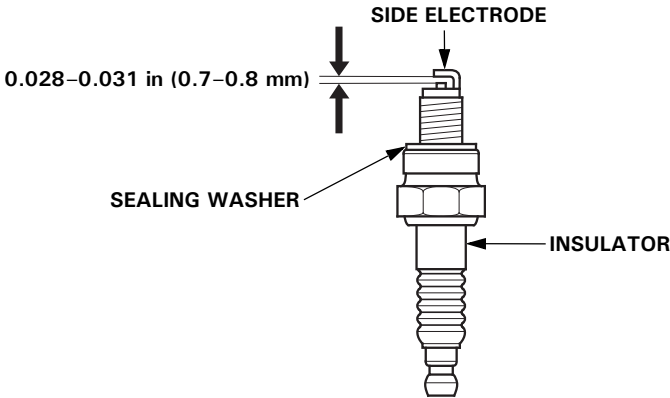

6. Check that the spark plug sealing washer is in good condition, and thread the spark plug in by hand to prevent cross-threading.
7. After the spark plug is seated, tighten with a spark plug wrench to compress the washer.

If installing a new spark plug, tighten 1/2 turn after the spark plug seats to compress the washer. If reinstalling a used spark plug, tighten 1/8–1/4 turn after the spark plug seats to compress the washer.

NOTICE

A loose spark plug can overheat and damage the engine. Overtightening the spark plug can damage the threads in the cylinder head.

8. Reinstall the spark plug cap on the spark plug securely.

SERVICING YOUR GENERATOR

SPARK ARRESTER SERVICE

If the generator has been running, the muffler will be very hot. Allow it to cool before proceeding.

The spark arrester must be serviced every 100 hours to maintain its efficiency.

1. Remove the 4 mm self-tapping screw, and remove the spark arrester from the muffler.

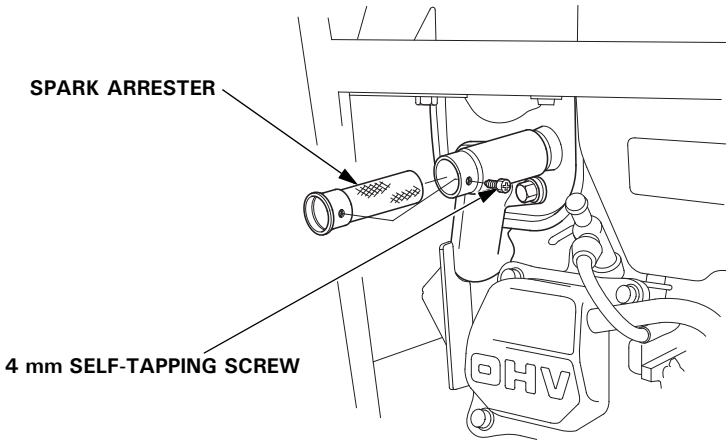

2. Use a brush to remove carbon deposits from the spark arrester screen.

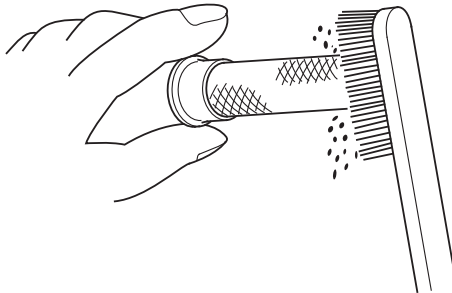

3. Inspect the screen for breaks or tears and replace it if necessary.
4. Install the spark arrester in the reverse order of removal.

STORAGE

STORAGE PREPARATION

Proper storage preparation is essential for keeping your generator trouble-free and looking good. The following steps will help to keep rust and corrosion from impairing your generator's function and appearance, and will make the engine easier to start when you use the generator again.

Cleaning

Wipe the generator with a moist cloth. After the generator has dried, touch up any damaged paint, and coat other areas that may rust with a light film of oil.

Fuel

NOTICE

Depending on the region where you operate your equipment, fuel formulations may deteriorate and oxidize rapidly. Fuel deterioration and oxidation can occur in as little as 30 days and may cause damage to the carburetor and/or fuel system. Please check with your servicing dealer for local storage recommendations.

Gasoline will oxidize and deteriorate in storage. Old gasoline will cause hard starting, and it leaves gum deposits that clog the fuel system. If the gasoline in your generator deteriorates during storage, you may need to have the carburetor and other fuel system components serviced or replaced.

The length of time that gasoline can be left in your fuel tank and carburetor without causing functional problems will vary with such factors as gasoline blend, your storage temperatures, and whether the fuel tank is partially or completely filled. The air in a partially filled fuel tank promotes fuel deterioration. Very warm storage temperatures accelerate fuel deterioration. Fuel deterioration problems may occur within a few months, or even less if the gasoline was not fresh when you filled the fuel tank.

The *Distributor's Limited Warranty* does not cover fuel system damage or engine performance problems resulting from neglected storage preparation.

You can extend fuel storage life by adding a gasoline stabilizer that is formulated for that purpose, or you can avoid fuel deterioration problems by draining the carburetor, sediment cup (if applicable) and/or fuel tank.

STORAGE

Service according to the table below:

STORAGE TIME	RECOMMENDED SERVICE PROCEDURE TO PREVENT HARD STARTING
Less than 1 month	No preparation required
1 to 2 months	Fill with fresh gasoline and add gasoline stabilizer*.
2 months to 1 year	Fill with fresh gasoline and add gasoline stabilizer*. Drain the carburetor float bowl (see page 49). Drain the fuel sediment cup (see page 42).
1 year or more	Fill with fresh gasoline and add gasoline stabilizer*. Drain the carburetor float bowl (see page 49). Drain the fuel sediment cup (see page 42). Remove the spark plug. Put a teaspoon of engine oil into the cylinder. Turn the engine slowly with the stater grip to distribute the oil. Reinstall the spark plug. Change the engine oil (see page 38). After removal from storage, drain the stored gasoline into a suitable container, and fill with fresh gasoline before starting.
*Use gasoline stabilizers that are formulated to extend storage life. Follow the manufacturer's instructions for use. Contact your authorized Honda generator dealer for stabilizer recommendations.	

Draining the Fuel Tank and Carburetor

⚠ WARNING

Gasoline is highly flammable and explosive.

You can be burned or seriously injured when handling fuel.

- Stop the engine and keep heat, sparks, and flame away.
- Handle fuel only outdoors.
- Wipe up spills immediately.

1. Place a suitable gasoline container below the carburetor.
2. Turn the fuel valve lever to the OFF position, loosen the carburetor drain bolt by turning 1 to 2 turns counterclockwise, and drain the fuel from the carburetor.
3. Remove the sediment cup (see page 42), and then turn the fuel valve lever to the ON position and drain the fuel from the fuel tank.
4. After all the fuel has drained into the container, tighten the carburetor drain bolt securely.
5. Install the sediment cup and a new O-ring.
6. Turn the fuel valve lever to the OFF position.

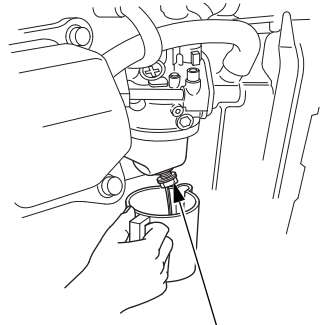

CARBURETOR DRAIN BOLT

STORAGE

Engine Oil

1. Change the engine oil (see page 38).
2. Remove the spark plug (see page 44).
3. Pour a teaspoon (5 cc) of clean engine oil into the cylinder.
4. Pull the starter rope several times to distribute the oil in the cylinder.
5. Reinstall the spark plug (see page 45).
6. Slowly pull the starter grip until resistance is felt. At this point, the piston is coming up on its compression stroke and both the intake and exhaust valves are closed. Storing the engine in this position will help to protect it from internal corrosion. Return the starter grip gently.

STORAGE PRECAUTIONS

If your generator will be stored with gasoline in the fuel tank and carburetor, it is important to reduce the hazard of gasoline vapor ignition.

Select a well ventilated storage area away from any appliance that operates with a flame, such as a furnace, water heater, or clothes dryer. Also avoid any area with a spark-producing electric motor, or where power tools are operated.

If possible, avoid storage areas with high humidity, because that promotes rust and corrosion.

Unless all fuel has been drained from the fuel tank, leave the fuel valve in the OFF position to reduce the possibility of leakage.

Place the generator on a level surface. Tilting can cause fuel or oil leakage.

With the engine and exhaust system cool, cover the generator to keep out dust. A hot engine and exhaust system can ignite or melt some materials.

Do not use sheet plastic as a dust cover. A nonporous cover will trap moisture around the generator, promoting rust and corrosion.

REMOVAL FROM STORAGE

Check your generator as described in the *BEFORE OPERATION* chapter of this manual.

If the generator was stored for 1 year or longer, drain the fuel tank (see page 49) and refuel with fresh gasoline. If you keep a container of gasoline for refueling, be sure that it contains only fresh gasoline. Gasoline oxidizes and deteriorates over time, causing hard starting.

If the cylinder was coated with oil during storage preparation, the engine may smoke briefly at startup. This is normal.

TRANSPORTING

NOTICE

Do not lay the generator on its side when moving, storing, or operating it. Oil or fuel may leak and damage the engine or your property.

If the generator has been used, allow it cool for at least 15 minutes before loading the generator on the transport vehicle. A hot engine and exhaust system can burn you and can ignite some material.

When transporting the generator, turn the engine switch and the fuel valve lever OFF, and keep the generator level to reduce the possibility of fuel leakage.

Take care not to drop or strike the generator when transporting. Do not place heavy objects on the generator.

TAKING CARE OF UNEXPECTED PROBLEMS

ENGINE WILL NOT START

Possible Cause	Correction
Fuel valve lever OFF.	Turn lever ON (see page 23).
Engine switch OFF.	Turn engine switch to ON (see page 24).
Out of fuel.	Refuel (see page 35).
Bad fuel; generator stored without treating or draining gasoline, or refueled with bad gasoline.	Drain fuel tank and carburetor (see page 49). Refuel with fresh gasoline (see page 35).
Low oil level caused Oil Alert to stop engine.	Add oil (see page 37). Turn engine switch to OFF and then restart the engine.
Spark plug faulty, fouled, or improperly gapped.	Gap or replace spark plug (see page 44).
Spark plug wet with fuel (flooded engine).	Dry and reinstall spark plug.
Fuel filter restricted, carburetor malfunction, ignition malfunction, valves stuck, etc.	Take the generator to an authorized Honda servicing dealer, or refer to the shop manual.

TAKING CARE OF UNEXPECTED PROBLEMS

ENGINE LACKS POWER

Possible Cause	Correction
Air filter restricted.	Clean or replace air filter (see pages 40, 41).
Bad fuel; generator stored without treating or draining gasoline, or refueled with bad gasoline.	Drain fuel tank and carburetor (see page 49). Refuel with fresh gasoline (see page 35).
Fuel filter restricted, carburetor malfunction, ignition malfunction, valves stuck, etc.	Take the generator to an authorized Honda servicing dealer, or refer to the shop manual.

TAKING CARE OF UNEXPECTED PROBLEMS

NO POWER AT THE AC RECEPTACLES

Possible Cause	Correction
Output indicator blinks.	Check AC load. Stop and restart the engine.
	Check the cooling air inlet. Stop and restart the engine.
AC circuit breaker left in the OFF position after starting.	Check AC load and reset AC circuit breaker (see page 28).
GFCI activated.	Test GFCI (see page 26) and reset AC circuit breaker. Replace faulty power tool or appliance.
AC circuit protector tripped.	Check AC load and reset circuit protector (see page 13).
Faulty power tool or appliance.	Replace or repair power tool or appliance. Stop and restart the engine.
Faulty generator.	Take the generator to an authorized Honda servicing dealer, or refer to the shop manual.

TECHNICAL INFORMATION

Serial Number Location

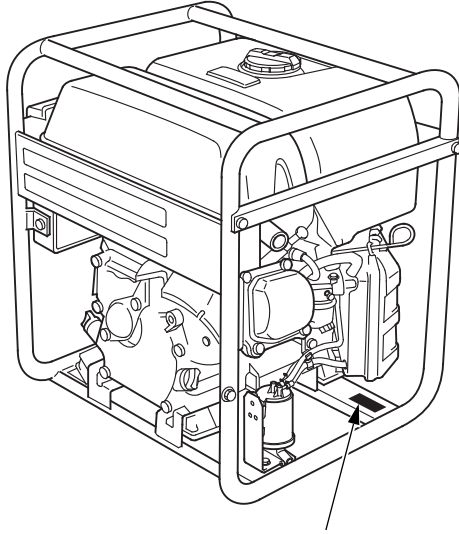

FRAME SERIAL NUMBER

Record the frame serial number in the space below. You will need this serial number when ordering parts, and when making technical or warranty inquiries.

Frame serial number: _____

Date purchased: _____

Carburetor Modification for High Altitude Operation

At high altitude, the standard carburetor air-fuel mixture will be too rich. Performance will decrease, and fuel consumption will increase. A very rich mixture will also foul the spark plug and cause hard starting. Operation at an altitude that differs from that at which this engine was certified, for extended periods of time, may increase emissions.

High altitude performance can be improved by specific modifications to the carburetor. If you always operate your generator at altitudes above 5,000 feet (1,500 meters), have your authorized Honda servicing dealer perform this carburetor modification. This engine, when operated at high altitude with the carburetor modifications for high altitude use, will meet each emission standard throughout its useful life.

Even with carburetor modification, engine horsepower will decrease about 3.5% for each 1,000-foot (300-meter) increase in altitude. The effect of altitude on horsepower will be greater than this if no carburetor modification is made.

NOTICE

When the carburetor has been modified for high altitude operation, the air/fuel mixture will be too lean for low altitude use. Operation at altitudes below 5,000 feet (1,500 meters) with a modified carburetor may cause the engine to overheat and result in serious engine damage. For use at low altitudes, have your servicing dealer return the carburetor to original factory specifications.

TECHNICAL INFORMATION

Emission Control System Information

Source of Emissions

The combustion process produces carbon monoxide, oxides of nitrogen, and hydrocarbons. Control of hydrocarbons and oxides of nitrogen are very important because, under certain conditions, they react to form photochemical smog when subjected to sunlight. Carbon monoxide does not react in the same way, but it is toxic.

Honda utilizes appropriate air/fuel ratios and other emissions control systems to reduce the emissions of carbon monoxide, oxides of nitrogen, and hydrocarbons.

Additionally, Honda fuel systems utilize components and control technologies to reduce evaporative emissions.

The U.S. and California Clean Air Acts

EPA and California regulations require all manufacturers to furnish written instructions describing the operation and maintenance of emission control systems.

The following instructions and procedures must be followed in order to keep the emissions from your Honda engine within the emission standards.

Tampering and Altering

NOTICE

Tampering is a violation of Federal and California law.

Tampering with or altering the emission control system may increase emissions beyond the legal limit. Among those acts that constitute tampering are:

- Removal or alteration of any part of the intake, fuel, or exhaust systems.
- Altering or defeating the governor linkage or speed-adjusting mechanism to cause the engine to operate outside its design parameters.

Problems That May Affect Emissions

If you are aware of any of the following symptoms, have your engine inspected and repaired by your authorized Honda servicing dealer.

- Hard starting or stalling after starting.
- Rough idle.
- Misfiring or backfiring under load.
- Afterburning (backfiring).
- Black exhaust smoke or high fuel consumption.

Replacement Parts

The emission control systems on your new Honda engine were designed, built, and certified to conform with EPA and California emission regulations. We recommend the use of genuine Honda parts whenever you have maintenance done. These original-design replacement parts are manufactured to the same standards as the original parts, so you can be confident of their performance. The use of replacement parts that are not of the original design and quality may impair the effectiveness of your emission control system.

A manufacturer of an aftermarket part assumes the responsibility that the part will not adversely affect emission performance. The manufacturer or rebuilder of the part must certify that use of the part will not result in a failure of the engine to comply with emission regulations.

Maintenance

Follow the *MAINTENANCE SCHEDULE* on page 34. Remember that this schedule is based on the assumption that your machine will be used for its designed purpose. Sustained high-load or high-temperature operation, or use in dusty conditions, will require more frequent service.

TECHNICAL INFORMATION

Air Index

(Models sold in California)

An Air Index Information label is applied to engines certified to an emission durability time period in accordance with the requirements of the California Air Resources Board.

The bar graph is intended to provide you, our customer, the ability to compare the emissions performance of available engines. The lower the Air Index, the less pollution.

The durability description is intended to provide you with information relating to the engine's emission durability period. The descriptive term indicates the useful life period for the engine's emission control system. See your *Emission Control System Warranty* for additional information.

Descriptive Term	Applicable to Emission Durability Period
Moderate	50 hours (0–80 cc, inclusive) 125 hours (greater than 80 cc)
Intermediate	125 hours (0–80 cc, inclusive) 250 hours (greater than 80 cc)
Extended	300 hours (0–80 cc, inclusive) 500 hours (greater than 80 cc) 1,000 hours (225 cc and greater)

TECHNICAL INFORMATION

Specifications

Dimensions

Model (Type)	EB3000c
Description code	EZGP
Length	17.5 in (445 mm)
Width	15.8 in (402 mm)
Height	18.9 in (480 mm)
Dry mass [weight]	71.0 lbs (32.2 kg)

Engine

Model	GX200T
Engine type	4-stroke, overhead valve, single cylinder
Displacement	12.0 cu-in (196 cm ³)
Bore × Stroke	2.68 × 2.13 in (68.0 × 54.0 mm)
Compression ratio	8.5:1
Engine speed	3,600 rpm
Cooling system	Forced air
Ignition system	Transistor magneto
Oil capacity	18 oz (0.55 L)
Fuel tank capacity	2.56 US gal (9.7 L)
Spark plug	BPR6ES (NGK) W20EPR-U (DENSO)

Generator

Model	EB3000c	
Type	A type	
AC output	Rated voltage	120 V
	Rated frequency	60 Hz
	Rated ampere	21.7 A
	Rated output	2.6 kVA
	Maximum output	3.0 kVA

Tuneup Specifications

ITEM	SPECIFICATION	MAINTENANCE
Spark plug gap	0.028–0.031 in (0.7–0.8 mm)	Refer to page: 45
Valve clearance (cold)	IN: 0.15 ± 0.02 mm EX: 0.20 ± 0.02 mm	See your authorized Honda dealer
Other specifications	No other adjustments needed.	

TECHNICAL INFORMATION

Wiring Diagram

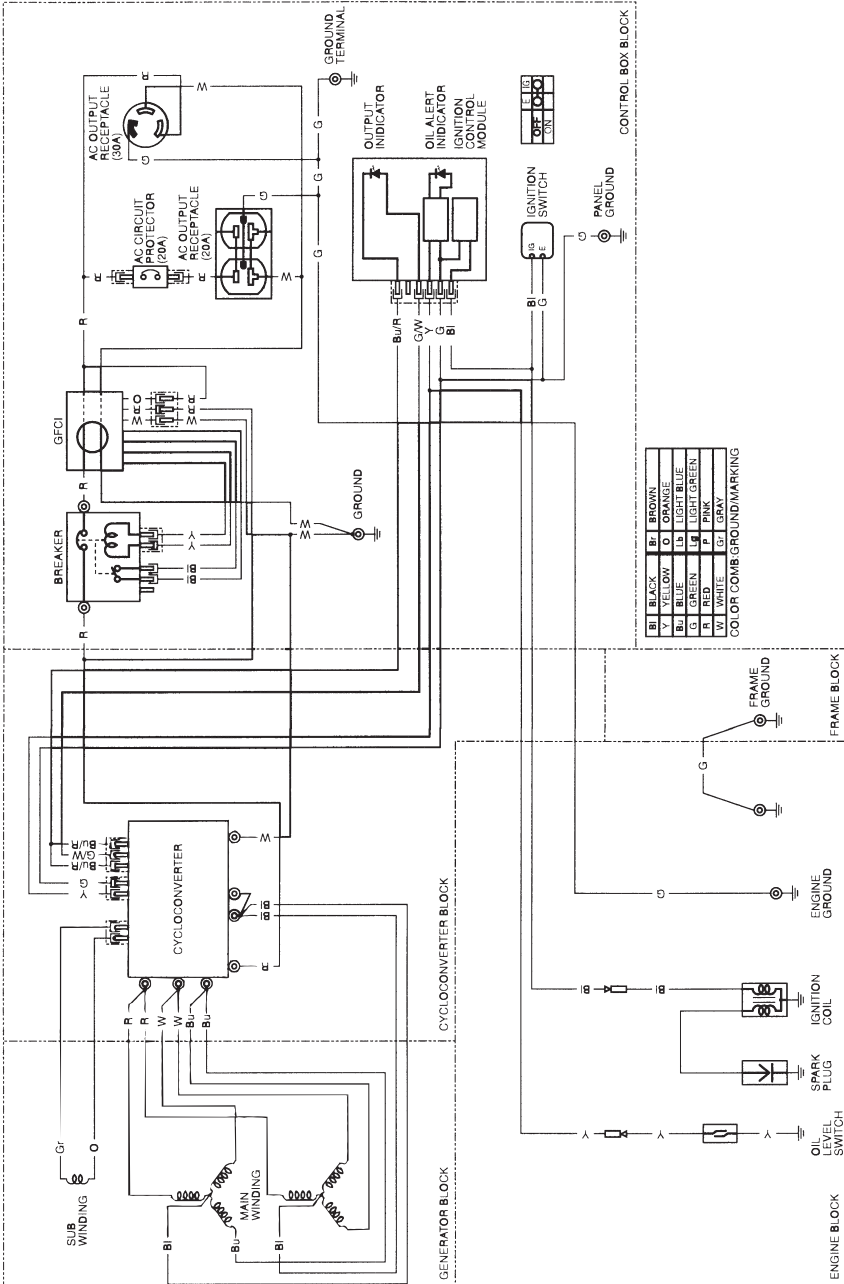

CONSUMER INFORMATION

Dealer Locator Information

To find an authorized Honda Servicing Dealer anywhere in the United States:

Visit our website:

<http://powerequipment.honda.com/dealer-locator>

Honda Publications

Shop Manual

This manual covers complete maintenance and overhaul procedures.

It is intended to be used by a skilled technician.

Available through your Honda dealer or visit

<http://powerequipment.honda.com/support/shop-manuals>

Parts Catalog

This manual provides complete, illustrated parts lists. Available through your Honda dealer.

CONSUMER INFORMATION

Customer Service Information

Honda Power Equipment dealership personnel are trained professionals. They should be able to answer any question you may have. If you encounter a problem that your dealer does not solve to your satisfaction, please discuss it with the dealership's management. The Service Manager or General Manager can help. Almost all problems are solved in this way.

If you are dissatisfied with the decision made by the dealership's management, contact the Honda Power Equipment Customer Relations Office. You can write:

American Honda Motor Co., Inc.
Power Equipment Division
Customer Relations Office
4900 Marconi Drive
Alpharetta, Georgia 30005-8847

Or telephone: (770) 497-6400 8:30 am to 7:00 pm ET

When you write or call, please give us this information:

- Model and serial numbers (see page 56)
- Name of the dealer who sold the generator to you
- Name and address of the dealer who services your generator
- Date of purchase
- Your name, address, and telephone number
- A detailed description of the problem

INITIAL USE INSTRUCTIONS

ENGINE OIL

The generator is shipped **WITHOUT OIL** in the engine.

1. Place the generator on a level surface.
2. Remove the oil filler cap.
3. Add enough oil to bring the oil level to the upper limit of the oil filler neck. SAE 10W-30 API service category SJ or later (or equivalent) is recommended for general use; for additional recommendations (see page 37).

Maximum oil capacity: 18 oz (0.55 L)

Do not overfill the engine with oil. If the engine is overfilled, the excess oil may be transferred to the air cleaner housing and air filter.

4. Reinstall the oil filler cap securely.

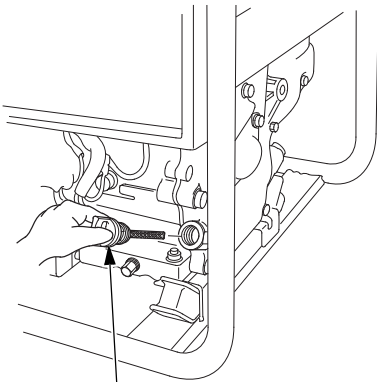

OIL FILLER CAP

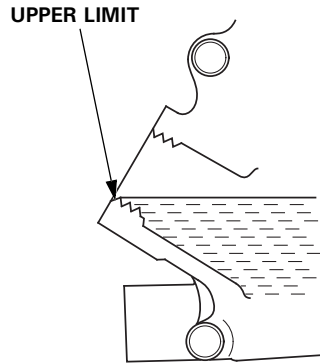

INITIAL USE INSTRUCTIONS

FUEL

Add fuel to the generator in a well-ventilated area. Never refuel the engine inside a building where gasoline fumes may reach flames or sparks. Keep gasoline away from appliance pilot lights, barbecues, electric appliances, power tools, etc. Spilled fuel is not only a fire hazard, it causes environmental damage. Wipe up spills immediately.

This engine is certified to operate on unleaded gasoline with a pump octane rating of 86 or higher. Refer to page 36 for additional fuel recommendations.

⚠ WARNING

Gasoline is highly flammable and explosive.

You can be burned or seriously injured when handling fuel.

- Stop the engine and keep heat, sparks, and flame away.
- Handle fuel only outdoors.
- Wipe up spills immediately.

1. Remove the fuel tank cap.
2. Fuel carefully to avoid spilling fuel. Do not fill the fuel tank above the upper level mark (red) on the fuel filter.
3. After refueling, reinstall the fuel tank cap securely.

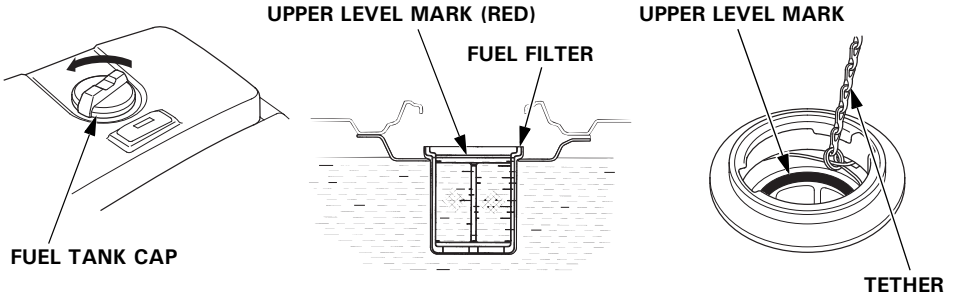

INITIAL USE INSTRUCTIONS

NOTICE

Fuel can damage paint and plastic. Be careful not to spill fuel when filling your fuel tank. Damage caused by spilled fuel is not covered under warranty.

Move the generator at least 10 feet (3 meters) away from the fueling source and site before starting the engine.

BEFORE OPERATION

Before using the generator, all generator operators must read the following chapters and sections:

- **GENERATOR SAFETY** (see pages 6 – 9)
- **CONTROLS & FEATURES** (see pages 10 – 19)
- **BEFORE OPERATION** (see pages 20 – 21)
- **OPERATION** (see page 22)
- **STARTING THE ENGINE** (see pages 23 – 24)
- **STOPPING THE ENGINE** (see page 25)
- **MAINTENANCE SCHEDULE** (see page 34)

REGISTRATION

Please Register Your Generator

If your dealer did not collect registration information from you, please take a few minutes and register your purchase with Honda. This allows us to contact you with any important updates regarding your generator. Please note registration is not required to obtain warranty service. You can register your generator by visiting the Honda Power Equipment website, <http://powerequipment.honda.com/support> and click on Product Registration. Your information will remain confidential. It will not be released to any other company or organization.

INDEX

A

AC Applications	30
AC Circuit Breaker	14
AC Circuit Protector	13
AC OPERATION	28
AIR CLEANER SERVICE	40
Air Index	60
ARE YOU READY TO GET STARTED?	20

B

BEFORE OPERATION	20, 67
------------------------	--------

C

Carbon Monoxide Hazards	6
Carburetor Modification for High Altitude Operation	57
Check the Engine	21
Check the GFCI	21
Choke Rod	12
Cleaning	47
COMPONENT & CONTROL LOCATIONS	10
Connections to a Building's Electrical System	31
CONSUMER INFORMATION	63
CONTENTS	3
CONTROLS	12
CONTROLS & FEATURES	10
Customer Service Information	64

D

Dealer Locator Information	63
----------------------------------	----

E

Electric Shock Hazards	7
Emission Control System Information	58
ENGINE LACKS POWER	54
Engine Oil	50, 65
ENGINE OIL CHANGE	38
ENGINE OIL LEVEL CHECK	37
ENGINE OIL RECOMMENDATIONS	39
Engine Switch	12
ENGINE WILL NOT START	53

F	
FEATURES	16
Fire and Burn Hazards	7
FOAM AIR FILTER CLEANING	41
Fuel	47, 66
Fuel Gauge	19
FUEL RECOMMENDATIONS.....	36
Fuel Valve Lever.....	12
G	
GENERATOR SAFETY	6
GFCI OPERATION CHECK.....	26
Ground Fault Circuit Interrupter (GFCI)	15
Ground Terminal	16
H	
Honda Publications	63
I	
IMPORTANT SAFETY INFORMATION	6
INDEX.....	68
INITIAL USE INSTRUCTIONS	65
IS YOUR GENERATOR READY TO GO?	20
K	
Knowledge	20

INDEX

M

MAINTENANCE SAFETY	33
MAINTENANCE SCHEDULE	34

N

NO POWER AT THE AC RECEPTACLES	55
--------------------------------------	----

O

Oil Alert Indicator	18
OPERATION.....	22
Operator Responsibility	6
Output Indicator	17

Q

QUICK REFERENCE INFORMATION	Inside back cover
-----------------------------------	-------------------

R

Recoil Starter	13
REFUELING.....	35
Refuel With Care	8
REGISTRATION.....	67
REMOVAL FROM STORAGE	51

S

SAFE OPERATING PRECAUTIONS	22
SAFETY LABEL LOCATIONS	9
Safety Precautions	33
SEDIMENT CUP CLEANING	42
Serial Number Location	56
SERVICING YOUR GENERATOR	32
SPARK ARRESTER SERVICE	46
SPARK PLUG SERVICE.....	44
Special Requirements	31
Specifications	61
STANDBY POWER.....	31
STARTING THE ENGINE	23
STOPPING THE ENGINE	25
STORAGE	47
STORAGE PRECAUTIONS	51
STORAGE PREPARATION.....	47
System Ground	31

T

TAKING CARE OF UNEXPECTED PROBLEMS	53
TECHNICAL INFORMATION	56
THE IMPORTANCE OF MAINTENANCE	32
TRANSPORTING	52

W

Wiring Diagram	62
----------------------	----

MEMO

QUICK REFERENCE INFORMATION

Fuel	Type	Unleaded gasoline with an ethanol content of no more than 10% and a pump octane rating of 86 or higher
Engine Oil	Type	SAE 10W-30, API SJ or later (or equivalent), for general use (see page 39)
Spark Plug	Type	BPR6ES (NGK) W20EPR-U (DENSO)
	Electrode Gap	0.028–0.031 in (0.7–0.8 mm)
Maintenance	Before each use	Check engine oil level. Check air filter. Check GFCI operation.
	First 20 hours	Change engine oil.
	Subsequent	See <i>MAINTENANCE SCHEDULE</i> (see page 34)

HONDA

The Power of Dreams

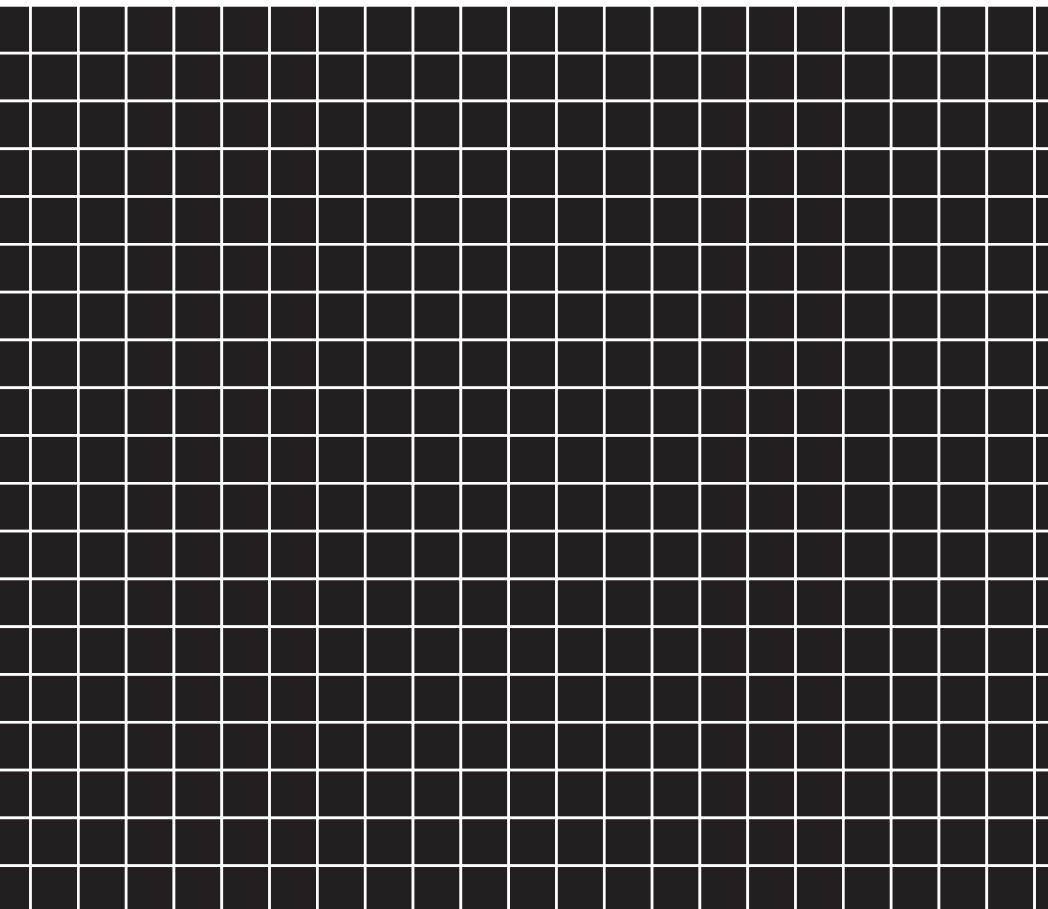

K2

31Z03721
00X31-Z03-7210

EM4

AH 英 N HC 3000.2014.02
Hi Printed in Japan