

Electronic Marshalling Overview

Electronic Marshalling is an innovative design for connecting field devices to a DeltaV™ Process Automation System. This document provides a detailed overview of what Electronic Marshalling is, as well as describes the benefits that it provides.

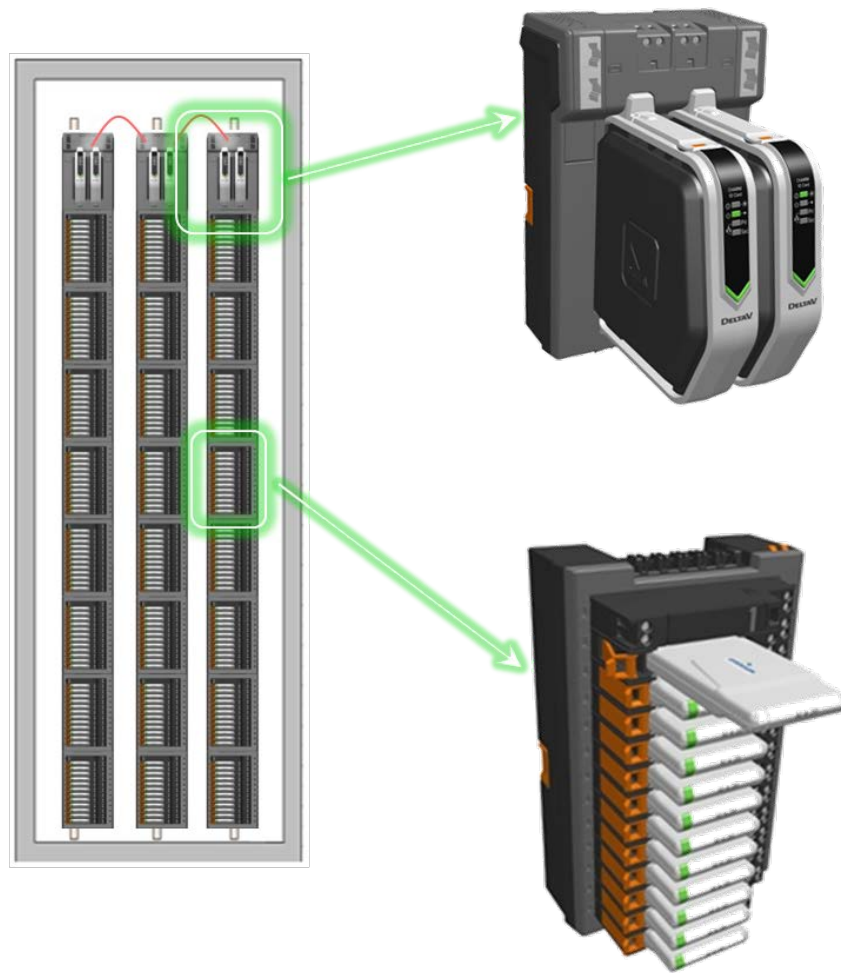

Table of Contents

Introduction..... 4

- Emerson’s Focus on Innovation – Never Been Done Before 4
- Complexity Paradox 4
- Human Centered Design..... 4

Project Challenges 5

- Project Work Flow 5
- Late Changes Come at a Price 6
- I/O on Demand..... 6

Current Industry Practice..... 7

- Bringing I/O into Control Today 7
- Problems with I/O Changes..... 8

A Better Way - Electronic Marshalling 9

Components of Electronic Marshalling 10

- Characterization Modules..... 10
- CHARM I/O Cards..... 10

Maximum Availability 11

- Redundancy 11
- Single Channel Integrity 11
- Communications 11

I/O Changes – No Problem! 12

- Late Changes – Different I/O Types 12
- Late Changes – I/O Additions 12

Additional Project Benefits	12
Footprint Reduction.....	12
Modernizing Traditional Control Systems.....	15
System Architecture Options	15
Current options.....	15
Where does Electronic Marshalling fit?	16

Introduction

Emerson's Focus on Innovation – Never Been Done Before

At Emerson Process Management, we truly believe that being first in the marketplace with technology innovations that change the landscape of the industries we serve is the way we differentiate and best meet our customer's needs. As a company, we spend close to US \$1 billion a year on such developments, and we even have targeted goals and metrics that make what's typically a subjective measure—innovation—into one that is much more objective. We go to great lengths to bring about innovations that have “Never Been Done Before”, and our business units are measured on the degree to which this is accomplished. First in a niche market, that's not bad, first in an industry, that's good, but first in the world, that's outstanding and will change the game for our end-users.

Complexity Paradox

Unfortunately, our customers have also reported back to us that they have a problem. Technology is not the answer in many cases. In fact, in many respects, ever advancing technologies can be more damaging than helpful. This is due to what we have termed “The Complexity Paradox”.

About four to five years ago, many of our customers, across almost all the market segments we serve, began coming to us and telling us about a very consistent concern and trend. Namely that finding and keeping experienced, skilled personnel to operate and maintain their facilities was becoming increasingly difficult. To make matters worse, today's process plants are more complex than ever and are being constructed in parts of the world that do not have abundant access to the rightly skilled labor force. So, if you take a seemingly ever-changing technology landscape, combined with fewer incoming skilled workers, you get the Complexity Paradox—a situation that innovation for the sake of innovation does nothing to solve.

Human Centered Design

With the Complexity Paradox in mind, several years ago, Emerson setup our Human Centered Design Institute. This group is dedicated to driving our innovations across all divisions to be very “Human Centered”. What does this mean? It means that Emerson strives to develop new technologies that focus on making tasks easier to accomplish, less complex, and that adapt to the human using the technology, instead of the other way around. At its core, Human Centered Design (HCD) is really built on three foundational principles:

- **Eliminating Unnecessary Work** – break a process down, analyze the tasks, and then eliminate as many as you can; that simplifies any process and saves time and money
- **Reduce Complexity** – for the remaining tasks that cannot be eliminated, make sure the technology simplifies the work, often this means removing features and functions, which is counter-intuitive to much innovation
- **Embed Knowledge** – directly improve the lack of skilled, trained workforce by making sure the technology embeds information from experts to be used by less-experienced workers

While the HCD philosophy sounds rather simple, when it is applied to all aspects of a control system, the results can be truly game changing. In fact, the topic of this white paper, Electronic Marshalling, was conceived by following the principles of HCD: take a common work flow, break it down into basic tasks, and see how innovation can eliminate steps, reduce complexity, and embed knowledge to change how the industry accomplishes the original work flow. In the coming sections, we will take a deeper look at how we feel this process has revolutionized the industry around marshalling of I/O.

Project Challenges

On-time, on-budget, on-schedule, safely - that is the most fundamental, basic goal faced by every process industry project or plant manager. Simple, and yet seeming impossible so much of the time. Part of the reason this becomes difficult is the aforementioned “Complexity Paradox” - more complexity and less experienced personnel to deal with the complexity. However, there are certainly other reasons that projects have become more difficult to manage:

- Schedules More Aggressive and Inflexible
- I&C Data Typically Late
- Typical Projects Assume Sequential Execution
- Projects Installed in “Hard-to-Staff” Locations
- On Job Realities and Unexpected Changes

All of these things drive work to be deferred to the field where it becomes upwards of ten times more expensive. One area that consistently plagues process automation projects are late change orders around I/O requirements. For example, perhaps an OEM package skid shows up to site with twenty-three additional I/O points, which previously were unaccounted. Or, maybe level transmitters show up on a skid where the design had called for level switches. Changes like this are common and can wreak havoc on an automation project, especially if they come in the field when a single day’s slip can cost millions of dollars.

Project Work Flow

Let us look at the most basic job of today’s automation systems like DeltaV™. Really the system is there to do a fairly straightforward task—bring a field measurement from the device into the control room so that an operator can take appropriate action. Of course this can take many forms, but this is the true gist of a modern day control system’s role. However, if we take a HCD focused look at this straightforward work process, it quickly unveils anything but simplicity. To accomplish this, there are many tasks, involving many individuals, requiring lots of work, lots of complexity. This is depicted in the figure below.

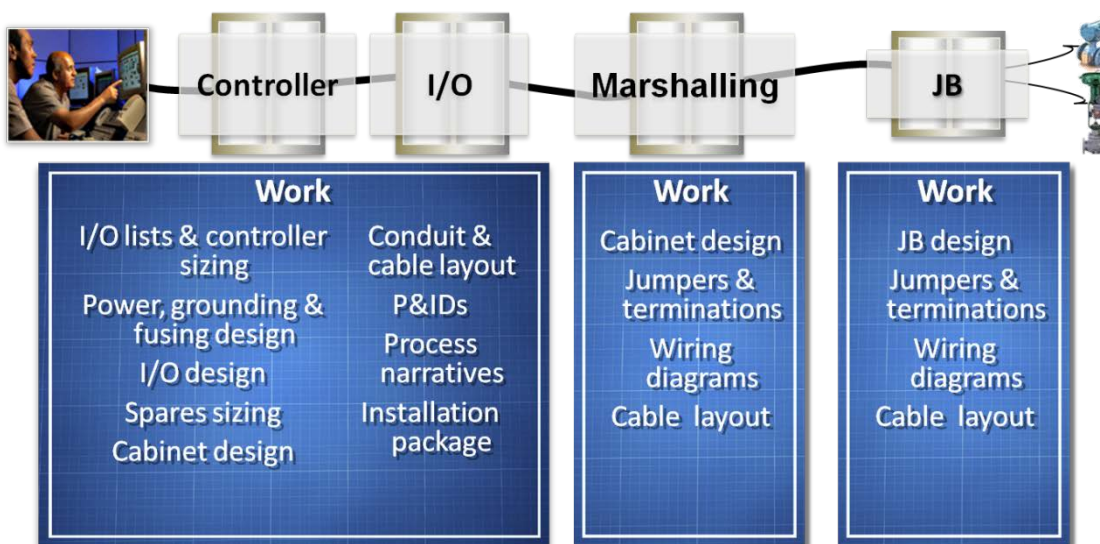

Figure 1 – Work Flow Diagram

Late Changes Come at a Price

What does the complexity shown in the above figure really mean? Well, it means that any late changes cost a lot of unbudgeted time and money. The amount of time spent modifying or changing a system goes up proportionally with that system's complexity, and when it comes to late changes around I/O requirements in an automation system, this fact is clearly born out.

Take the example of a skid that shows up with some additional, unexpected I/O, say 25 points. While most project teams would have planned for such an event and built in some "spares", there are several reasons why the changes can cause drastic re-work. First, there is a likelihood that the spares in place are not of the correct "type" of I/O (e.g. maybe the skid has extra 14 digital outputs, but there are only 8 available in the I/O subsystem for the skid). Further, there may not be enough room to expand by purchasing the correct type of card (DO card in this case). Even if there is room for additional I/O capacity from a card perspective, projects are under tremendous pressure to reduce costs up front, and therefore there may not be any room in the I/O cabinet itself. Lastly, after working through these complications, the drawings and wiring must be re-worked, which depending on skill sets and available resources, may or may not be possible, but will certainly be expensive in both time and costs.

The process of HCD forces one to ask, there has got to be a better way?

I/O on Demand

Emerson worked for several years on the above project challenge, specifically around that of late change orders associated with I/O requirements. We determined that system adaptability and flexibility of choice by the end-user is essential. So, with the latest release of our DeltaV Digital Automation System, we have announced the game changing DeltaV S-series with I/O on Demand. This new technology provides maximum choice and flexibility for performing an automation system's most basic task: getting field information into the control room so that good decisions can be made.

I/O on Demand is all about adaptability. It allows the end-user to have what type of I/O they want, when they want it, where ever they want it, or, more simply—I/O of any type, anytime, anywhere. With I/O on Demand, a project can bring the I/O into the control system in one of four distinct ways, selecting the best, most cost effective approach in each case.

- **Traditional Wiring** – basic 4-20ma signals, typically HART® enabled, utilizing long runs of bundled twisted pairs and associated "cross-marshalling" cabinets
- **Bussed** – multi-drop networks of devices allowing communications of not just process variables but also varying degrees of diagnostics
- **Wireless** – WirelessHART® or proprietary communication networks that allow the host system and field devices to communication measurements and diagnostics without the use of any wired connections
- **Electronic Marshalling** – a new, industry first, innovation that provides some of the benefits of bussed and wireless technologies to wired HART installation (the subject of this paper)

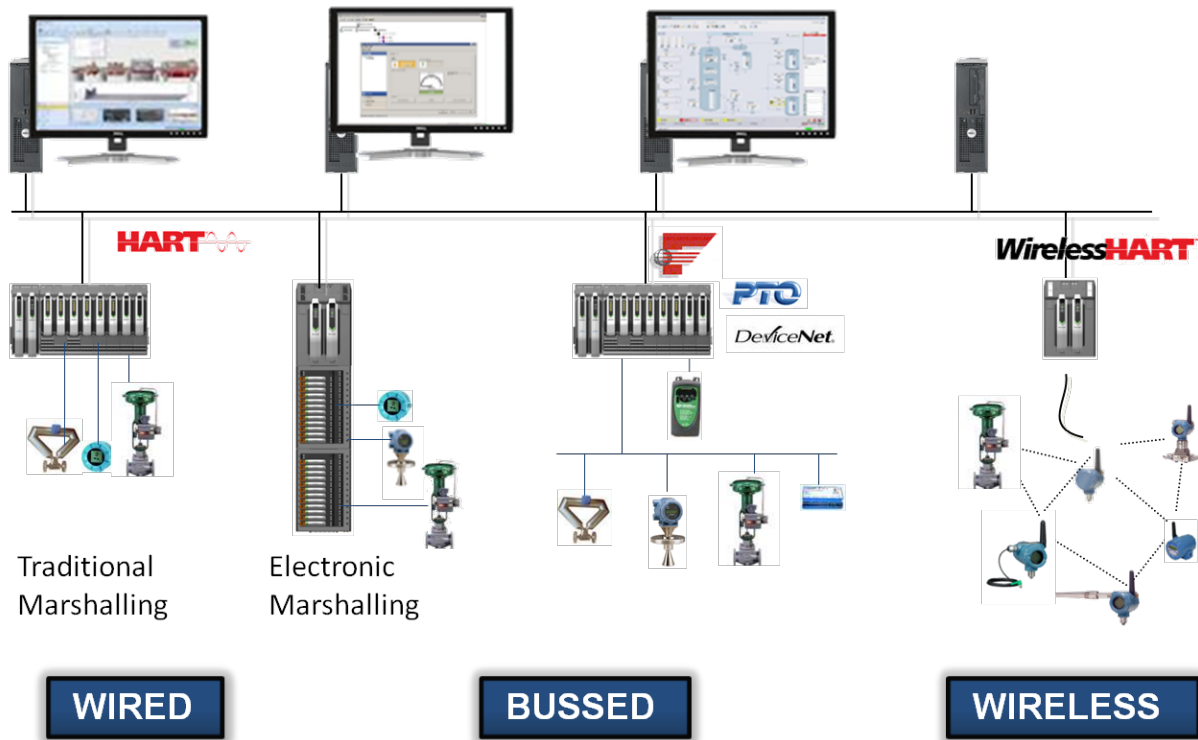

Figure 2 – System Diagram with I/O on Demand

Current Industry Practice

Bringing I/O into Control Today

For over 35 years the accepted industry practice of getting field devices connected to the Process Automation System has been by the means of traditional wired marshalling. Field technicians usually wire field devices to terminal blocks in marshalling panels in an I/O Room. The wires typically come from the field, through multi-core cables, to get them connected to the appropriate I/O cards in the controller cabinets. The wiring is cross-marshalled so the device gets connected to the appropriate I/O card and channel. While this has been the de facto industry practice, it has caused various problems that are frustrating for everyone involved in the project - technicians, integrators, control engineers, and project managers. For example, during cross-marshalling, it becomes harder and harder to keep track where wires are going from and to, which can cause human errors if wires are connected to wrong place or left out all together. When the cross-marshalling is done and tested out, we should be OK – that is, if there are no late I/O changes.

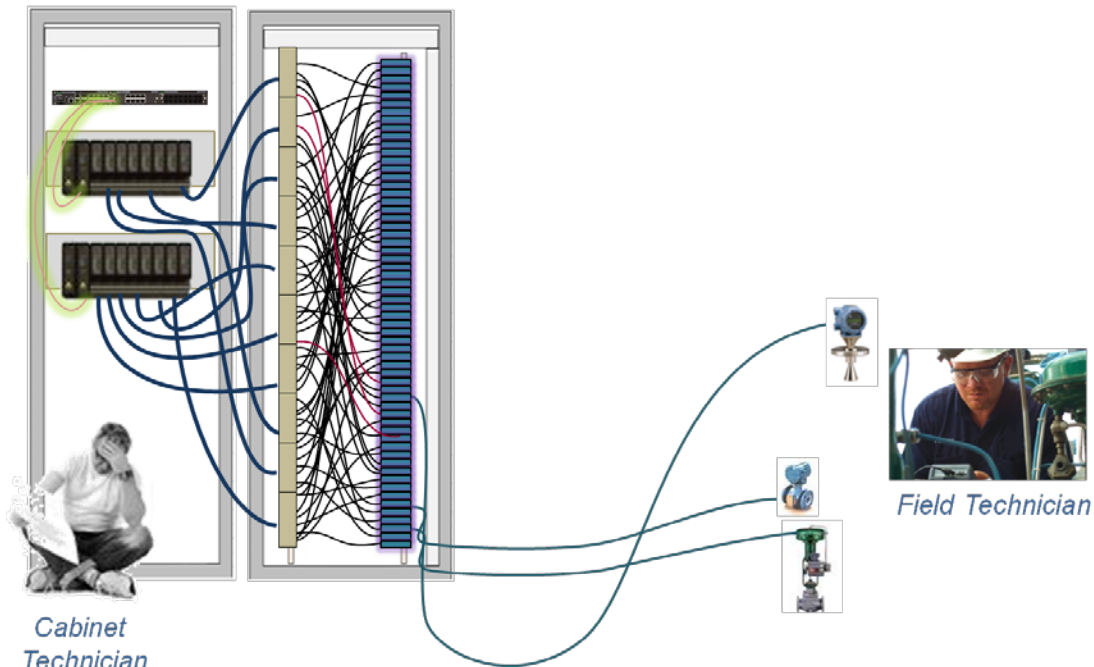

Figure 3 – Traditional Wired Marshalling

Problems with I/O Changes

Some of the largest frustrations with implementing process control system projects today are late changes around I/O requirements, which ripple through the entire implementation. I/O changes can mean rework on drawings, control system partitioning, moving wires, building new cabinets, and many other detailed tasks. These changes add cost, time, and most importantly, risk to the project. The practice of cross-marshalling only intensifies these problems. Let us look at some of these problems in detail.

Changes to I/O late in the project

Inevitably, I/O has to be added or changed late in the project. Maybe a pressure switch gets changed to a pressure transmitter, so a Discrete Input needs to be changed to an Analog Input. Or, maybe a skid has not been accounted for and suddenly the system has to accommodate for a number of new I/O points and a controller with spare I/O capacity has to be found. At a minimum, this means time consuming and frustrating rewiring of the cross-marshalling, a task that by itself can blow the project schedule and delay a critical startup. Additional costs may occur if there is not enough extra capacity in the cards.

Most importantly though, the fact that delays can happen increases the risk associated with the project. Many I/O changes, or sometimes for other reasons, it is necessary to split up a controller, which can cause additional delays to the project.

Splitting a controller

A controller may have to be 'split' if more I/O is required, but no single controller can handle the new I/O. This means that configuration and I/O for process equipment has to be moved from one controller to a new one. Control configuration is usually easy to reassign to a new controller, but physically moving I/O cards and cross-marshalling can be more complex. First of all, if I/O that has already been cross-marshalled needs to be moved to another controller, the multi core cables from the field have to be moved from one marshalling panel to another. Then the cross-marshalling has to be redone, which causes costly delays. This may also increase the need for panel space, and will definitely increase engineering time and result in changes to engineering drawings. Sometimes, it will be cheaper to just send the cabinet back to the factory to have it re-worked versus completing the work in the field.

A Better Way - Electronic Marshalling

Electronic Marshalling – part of Emerson Process Management’s “I/O on Demand” was developed to focus on the areas of commissioning a process automation system that are the most complex, involve many hours of labor, or that can disrupt a project the most. Electronic Marshalling offers some unique value propositions, which can help alleviate the pains previously discussed. As in wired marshalling, the multi core cables from the field still land on the right side of the terminal blocks in the marshalling cabinet, so there are no changes to the work done by technicians that wire up the multi core cables from the field. However, there are no cross-marshalling wires; all of the work, design, and engineering associated with cross-marshalling simply go away, because each individual I/O channel will be Electronically Marshalled to any controller in the system. This means that the I/O can be bound to specific controllers at any stage in the project. If late changes are made to I/O types, or new I/O is added, no adjustments to existing wiring or the cabinets must be made. New I/O can be added to the marshalling cabinets and Electronically Marshalled to the controllers that need the I/O.

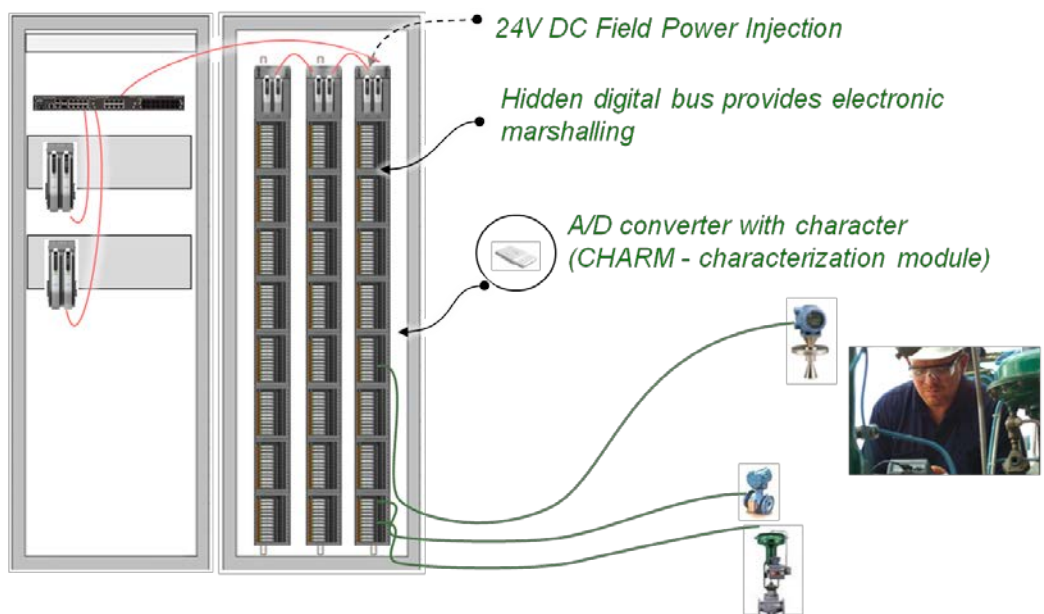

Figure 4 – Electronic Marshalling Overview

Components of Electronic Marshalling

Characterization Modules

CHARacterization Modules (CHARMs) are the components involved with Electronic Marshalling that allow the 'late characterization' of any type (AI, AO, DI, DO, RTD) of I/O signal. A CHARM is simply a component that includes a passive A/D converter and signal characterizer. CHARMs that are inserted onto the terminal block where field wires are landed. In fact, landing of field wires is much more forgiving, because the wires can be anywhere on the 'strip', without regard to a particular order or type of I/O. So, if wires for the following signals are landed: AI, AI, DI, DO, AO, DI, DO down the terminal strip, that is fine. After wiring, the technician sees the first channel is an AI, reaches into the bag of AI CHARMs, clicks in the CHARM and is done.

After the CHARM is in place, the channel is Electronically Marshalled to ANY controller in the system. The Electronically Marshalled cabinet with CHARMs is 100% functionally equivalent to the traditional Wired Marshalled cabinet. However, the work is done with many fewer wires, much less work, and, as we will see, with way more flexibility and a large reduction in change order hassles.

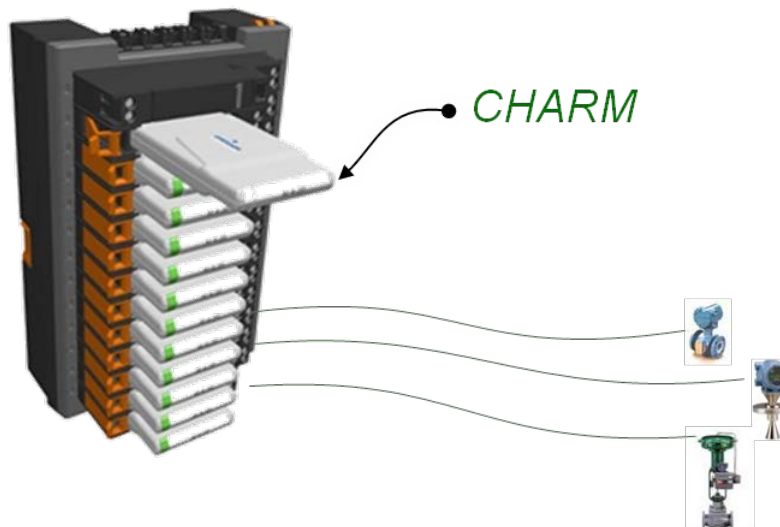

Figure 5 – Electronic Marshalling Base Plate and CHARMs, with CHARM shown partially removed

CHARMS are installed into individual terminal blocks, by simply clicking them into place. No screw driver is needed to remove either CHARM or the CHARM terminal block. The terminal blocks fit into a CHARM base plate, which holds 12 CHARM terminal blocks.

In the AI and AO CHARMs there is a HART modem per channel, which means faster HART communication than in traditional I/O cards where the HART modem is shared between channels. Electronic Marshalling with CHARMs also supports the newer v7 HART standard, giving more flexibility and richer diagnostics.

CHARM I/O Cards

The CHARM base plates are on a DIN rail, where a digital communication bus runs along the terminal strip to send device signal information to redundant CHARM I/O Cards (CIOC) at the top of the DIN rail. One CIOC can support 8 Base Plates, so there can be a total of 8 X 12 CHARMS on one CHARM I/O Card. It may help to think of it as a 96 channel I/O card with single channel integrity and single channel granularity (meaning you can pick and choose what I/O type you want).

The CIOC provides redundant communication to up to 4 individual DeltaV S-series controllers on the network. (Each controller can have up to 16 CHARMs assigned to it, making it flexible enough to easily facilitate any changes that are required.)

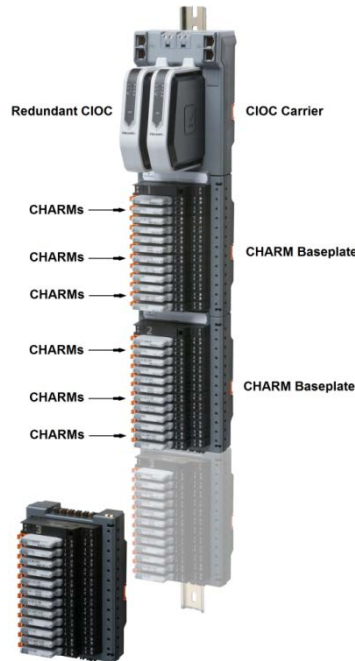

Figure 6 – Electronic marshalling details

Maximum Availability

The Electronic Marshalling solution has been designed and built for maximum availability.

Redundancy

All communications are completely redundant from the CHARM to the DeltaV S-series controller. The carrier for the redundant CIOCs has redundant communication modules for primary and secondary network connections. There is also a redundant power and communication backplane to the individual CHARMs.

Single Channel Integrity

With Electronic Marshalling (and the use of CHARMs), field problems are limited to a single channel, because CHARMs cannot be flashed, they are current limiting and they act as a fuse. A failure in one channel does not affect other I/O channels or the CIOC. With traditional I/O cards, one blown channel means that you will lose all other channels when the card is replaced. With CHARMs, you lose only the affected channel.

Communications

In the past, concerns have been raised about not having the I/O connected directly to the controller backplane and having to rely on Ethernet communications from I/O to controllers. This is not an issue of concern with Electronic Marshalling as the communication to S-series controllers has been improved to guarantee 250mS from screw terminal to screw terminal. An additional concern about loading of the control network is not an issue with Electronic Marshalling, as the DeltaV Control Network is built up on 100MB Ethernet with switches. Furthermore, the typical loading on the DeltaV Control Network is only around 3%, meaning that the “pipe” is virtually empty and has abundant bandwidth to accommodate more communication.

For more details on how Electronic Marshalling provides Maximum Availability, please see the Electronic Marshalling Robustness Whitepaper.

There is no loss of reliability or peace of mind with Electronic Marshalling. There *is* a flexible alternative to the cumbersome issues associated with I/O changes when systems are traditionally wired and cross-marshalled.

I/O Changes – No Problem!

Let's do a comparison how I/O changes are handled with Electronic Marshalling versus traditional wiring.

Late Changes – Different I/O Types

As mentioned earlier, there are always changes to I/O late in the project. One of our examples was a pressure switch that gets changed to a pressure transmitter, which means that wires originally connected to a DI card now must go to an AI card. The tedious tasks of finding the cross-marshalling wire for the signal (in the rat's nest) and relocating it to a new I/O card (assuming there are spares on the card) is the work done for traditional wiring. With Electronic Marshalling, a signal change from a DI to an AI is much simpler and faster. If the DI CHARM had already been installed, it simply needs to be replaced by an AI CHARM. No rewiring or searching for the right card type with 'spares'.

Late Changes – I/O Additions

Traditionally, the tasks are even more time consuming and frustrating when there are more numerous changes with I/O late in a project or during additions to a running facility. Large changes to an I/O system sometimes result in a controller having to be 'split'. However, with Electronic Marshalling, each individual CHARM (so, a single signal) can be assigned to *any* controller on the network. Need to add 2 AIs, 1AO, 4 DIs and 2 DOs? No problem! Just find a CHARM I/O card that has available base plates, wire the field wires to the terminal blocks and bind the I/O to the controller that needs it in the engineering software. Again, there is not a concern about finding space with the 'right' kind of I/O card. CHARMS are available for any type of signal, in any location on the DIN rail.

Neither of these late change examples requires a single wire to be relocated. That is impossible with a traditionally wired system. This means that late changes can be handled much more quickly, by eliminating rewiring and avoiding the time consuming task of splitting a controller in two and moving the I/O cables.

Additional Project Benefits

Some of the potential benefits to a project have been mentioned above and are the most obvious ones – less risk, more flexibility, capabilities for late I/O changes with little effort, less wiring and easier installation. Below we will discuss some more specific benefits to both Greenfield and Brownfield installations.

Footprint Reduction

It is easy to see that by eliminating cross-wiring, there will be a reduction in the amount of cabinet space required. A smaller space requirement can be beneficial for both new facilities and additions to existing facilities. We have been talking in general about Electronic Marshalling in cabinets that are in a designated climate-controlled I/O Room. However, Electronic Marshalling can just as easily be installed in junction boxes, in the field. Let's take a look at the footprint reduction for both of these options.

Electronic Marshalling in Cabinets

Traditional field wiring going to the I/O Room, with cross-marshalling, can have about 160 I/O signals wired in one standard-sized cabinet. The cabinet is full with just the field wires being terminated and cross-marshalled.

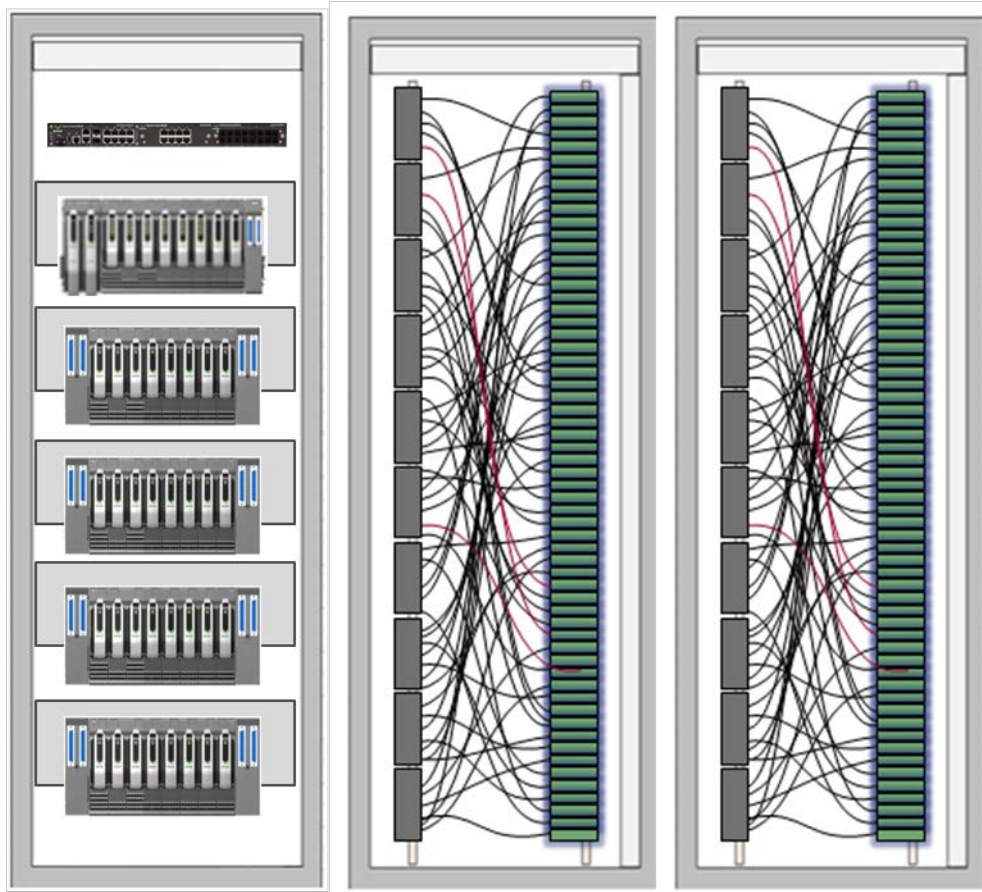

Figure 7 – Traditional Wiring of ~320 Signals, Classic I/O Cards with Cross-Marshalling

In contrast, with Electronic Marshalling and DeltaV Electronic Marshalling Cabinets, a cabinet with just front access can hold 288 I/O signals, as well as three pair of redundant CHARM I/O Cards. Those figures are doubled for a cabinet that has both front and rear access. (For details on the DeltaV Electronic Marshalling Cabinets, please refer to the [DeltaV Enclosures Whitepaper](#) and to the [CHARM Cabinets CTO Data Sheet](#)).

In addition to reduction in marshalling cabinet space requirements, there is a reduction in space requirements for I/O cards and backplanes, with Electronic Marshalling. CHARM I/O Cards can handle up to 96 I/O signals, and, with CHARMS Cabinets, they are mounted in the same cabinet as the field wiring and termination blocks. One CIOC could be replacing as many as 12 traditional I/O cards, which greatly reduces the I/O card footprint.

Comparing Figures 7 and 8, you can see that one cabinet is fully eliminated with Electronic Marshalling, even with nearly doubling the number of I/O signals. Also, the cabinet that would traditionally house the controller and I/O cards, now just has a couple of controllers. There is plenty of 'extra' room in that cabinet for network components, more controllers or other DeltaV cards (busses, traditional I/O).

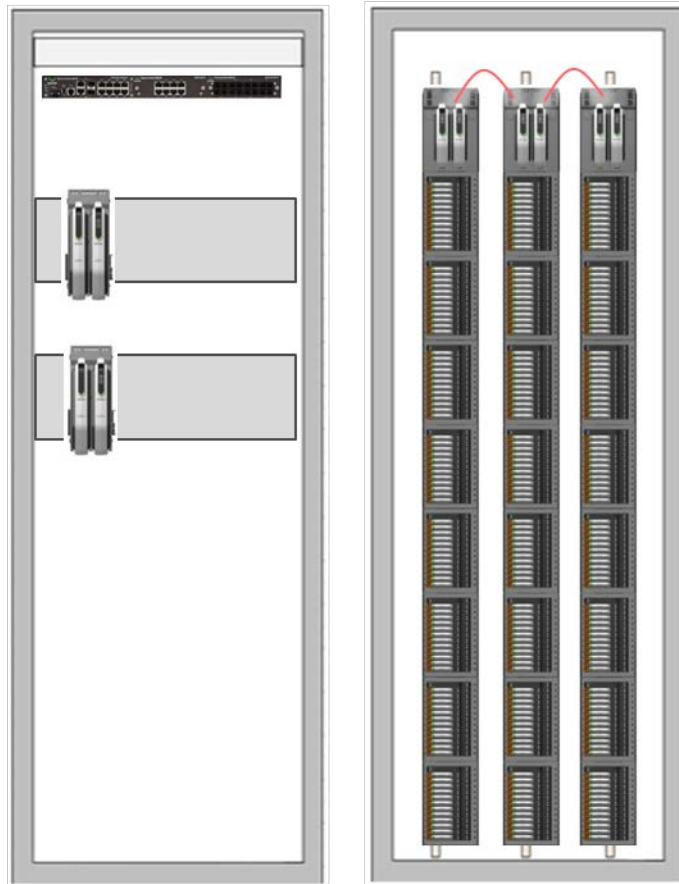

Figure 8 – Electronic Marshalling of ~580 Signals, CIOCs, Front and Rear Cabinet Access

Reduction in the number of cabinets required could significantly reduce project costs for a Greenfield installation, in that fewer cabinets requires less space, and the cost benefits trickle down to the bottom line.

There is generally very little space allocated in a project for any future expansion. So, adding I/O in a Brownfield installation could affect the existing system because cabinets or other components must be moved to make room for the expansion. Depending on the size of the expansion, additional building space may even be required. Being able to add controllers and I/O with such a small footprint is a huge benefit. Using Electronic Marshalling for a plant expansion may eliminate moving / rearranging of existing I/O cabinets or the need to for additional building space.

Electronic Marshalling in Field Enclosures

Electronic Marshalling panels can also be located in field Enclosures. This, of course, would reduce the system footprint requirements even more, only one cabinet would be needed in for the DeltaV controllers. CIOCs, CHARM backplanes, termination blocks and CHARMS can all be installed in a field Enclosure, close to the field devices. Copper or fiber optic wires are then run from the CIOCs to the controller cabinets.

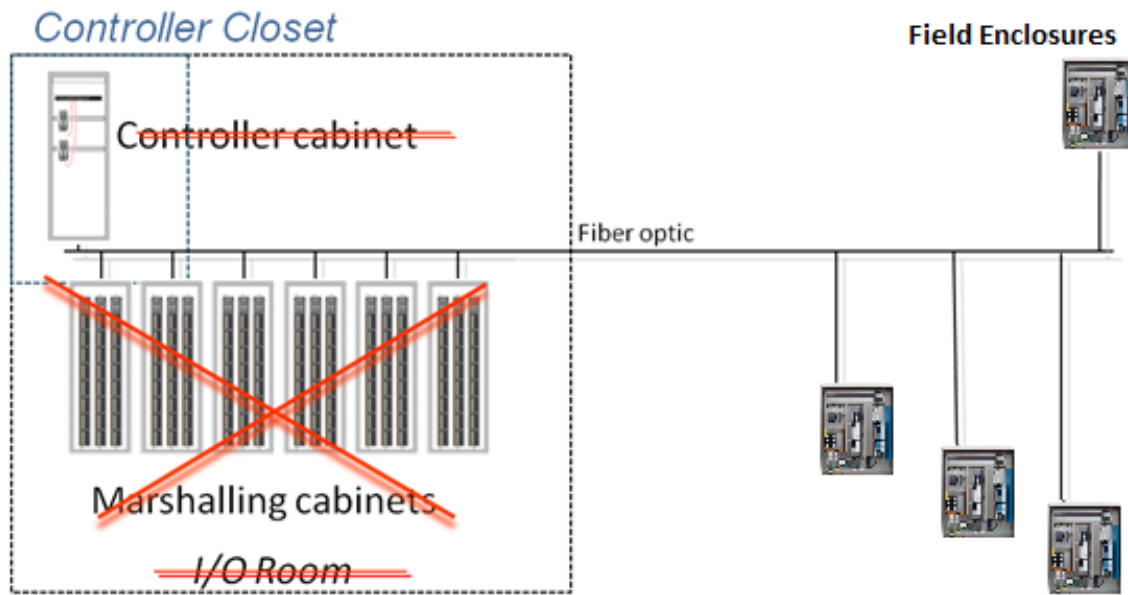

Figure 9 – Electronic Marshalling in Field Enclosures

What would have been an entire room for controllers and I/O cabinets can be just a closet for controller cabinets!

For a Greenfield Reduction, again, the project would see a significant reduction in the project cost due to reduced I/O room requirements. In addition, there would be a considerable decrease in costs due to the very few cabinets required.

As mentioned before, it is rare for existing facilities to have extra room allocated for any potential future expansions. With Electronic Marshalling in field Enclosures, users only have to 'find' space for the new controllers. Again, the expansion project would also see lower costs due to not having to purchase marshalling cabinets, not moving existing equipment or not having to add building space. (For details on the DeltaV Electronic Marshalling Field Enclosures, please refer to the [Field Enclosures CTO Data Sheet](#)).

Modernizing Traditional Control Systems

Electronic marshalling can also very effectively be used to simplify modernization and migration of legacy DCS system to the DeltaV Process Automation System. Please refer to the following whitepapers for more information about this topic. Please see [I/O on Demand Cost Study](#) and [Modernizing with I/O on Demand](#) whitepapers.

System Architecture Options

Emerson has always been a proponent of open standards and supports many ways of bringing field data into the DeltaV system. Electronic Marshalling is considered to complement the existing technologies, but it will offer more flexibility where traditional I/O and wired marshalling otherwise would have been used.

Current options

Previously we have discussed how wired field devices have been connected into a Process Automation System using wired marshalling panels. This section will discuss some of the other ways of bringing field devices into the process control system. HART, FOUNDATION Fieldbus, WirelessHART, and other bus technologies have allowed for rich diagnostics information from the devices to be brought to the Process Automation System.

Wired HART

Wired HART technology has been around since the mid 1980s and has delivered diagnostics to Process Automation Systems and Asset Management Systems. HART had 1200 baud communication speed and required host systems to request the information from the devices. This meant that the information was available, but the communication limitations could make the information flow slow. With HART v7, there are many new features that allow more information to be transferred from the devices.

Busses (discrete, device, field)

Ever since the late 1980s and early 1990s various bus technologies have emerged. DeltaV supports the most used bus technologies, such as AS-i bus, Profibus DP, DeviceNet, and FOUNDATION Fieldbus. Each bus technology has its own application and, except for Profibus DP and DeviceNet, none of the busses compete head to head against each other. The rich diagnostics information from the smart bussed devices provides rich diagnostics information that makes them invaluable in many applications. Emerson believes in the continued adoption of bussed technology and actually adds more functionality to our bus interface cards to improve usability. Two examples of this are the lately introduced H1 FOUNDATION Fieldbus device with integrated power and diagnostics and the redundant Profibus DP interface card.

Wireless

Wireless device networks have recently emerged as a new technology in the process automation market. Since the release of v10.3, DeltaV has supported native wireless device networks that adhere to the WirelessHART standard, the most adopted wireless standard in the market today with over 1000 installations globally. Initially, wireless technology offered a way to monitor measurement that previously had been too costly to bring in to the Process Control System. Wireless adoption is increasing and offers tremendous cost savings potential for installations worldwide, and is not only used for monitoring any longer, but also in control applications.

Where does Electronic Marshalling fit?

With all the technologies mentioned above, the following comes to mind: where does Electronic Marshalling fit? Will Electronic Marshalling displace bussed technologies or wireless technology? Emerson does not see these technologies as competing against each other, but rather as complementing technologies. Depending on different situations and customer preferences, each technology will have its ideal applications. For example, if a customer is well versed in FOUNDATION Fieldbus and is doing an expansion, FOUNDATION Fieldbus is probably the way to go. On the other hand if a customer has no experience with busses and does not want to adapt to the newer technology, Electronic Marshalling is a better solution that will offer some of the benefits of FOUNDATION Fieldbus. For example, there will be a decrease in wiring and diagnostics from the field devices, without the learning curve of changing work practices that are sometimes required when implementing bus technologies. Electronic Marshalling gives some of the benefits of bussed I/O, such as reduced wiring, reduced footprint, more diagnostics, and more flexibility to change or add devices, while still using traditionally wired HART devices.

This page intentionally left blank.

To locate a sales office near you, visit our website at:

www.EmersonProcess.com/DeltaV

Or call us at:

Asia Pacific: 65.6777.8211

Europe, Middle East: 41.41.768.6111

North America, Latin America: +1 800.833.8314 or
+1 512.832.3774

For large power, water, and wastewater applications

contact Power and Water Solutions at:

www.EmersonProcess-powerwater.com

Or call us at:

Asia Pacific: 65.6777.8211

Europe, Middle East, Africa: 48.22.630.2443

North America, Latin America: +1 412.963.4000

© Emerson Process Management 2013. All rights reserved. For Emerson Process Management trademarks and service marks, go to:
<http://www.emersonprocess.com/home/news/resources/marks.pdf>.

The contents of this publication are presented for informational purposes only, and while every effort has been made to ensure their accuracy, they are not to be construed as warranties or guarantees, express or implied, regarding the products or services described herein or their use or applicability. All sales are governed by our terms and conditions, which are available on request. We reserve the right to modify or improve the design or specification of such products at any time without notice.



DELTA V

www.DeltaV.com



EMERSON
Process Management