



SiFive U74-MC Manual
v19.08p3p0

© SiFive, Inc.

SiFive U74-MC Manual

Proprietary Notice

Copyright © 2019–2020, SiFive Inc. All rights reserved.

Information in this document is provided “as is,” with all faults.

SiFive expressly disclaims all warranties, representations, and conditions of any kind, whether express or implied, including, but not limited to, the implied warranties or conditions of merchantability, fitness for a particular purpose and non-infringement.

SiFive does not assume any liability arising out of the application or use of any product or circuit, and specifically disclaims any and all liability, including without limitation indirect, incidental, special, exemplary, or consequential damages.

SiFive reserves the right to make changes without further notice to any products herein.

Release Information

Version	Date	Changes
v19.08p3p0	April 30, 2020	<ul style="list-style-type: none"> • Fixed issue in which mcause values did not reset to 0 after reset • Added the "Disable Speculative I\$ Refill" bit to the Feature Disable CSR to partially mitigate undesired speculative accesses to the Memory Port • Fixed issue in which unused logic in asynchronous crossings (as found in the Debug connection to the core) would cause CDC lint warnings • Fixed issue in which a read of the L2 Cache via its sideband interface could fail to report an ECC error if the read occurred immediately after the corrupt data was written • Fixed issue in which a read of the L2 Cache via its sideband interface could erroneously report an ECC error if the read occurred immediately after data with good ECC was written • Fixed issue in which WFI did not gate the clock if the following instruction was a memory access • Fixed issue in which performance counters set to count both exceptions and other retirement events only counted the exceptions • Added a "Suppress Grant on Corrupt Data" bit to the Feature Disable CSR to mitigate issue in which it was impossible to clear an uncorrectable D-Cache ECC error from the core experiencing the error • Fixed issue in which possible livelock could occur in U7 cores during concurrent ITLB and DTLB misses • Fixed a potential bus hang when flushing L2 • Fixed an issue in which ITIM fetch data could be corrupted due to uninitialized I-Cache tags • Various documentation fixes and improvements
v19.08p2p0	December 06, 2019	<ul style="list-style-type: none"> • Fixed erratum in which stval/mtval CSRs are not sign-extended for instruction access/page fault exceptions • Fixed erratum in which the TDO pin may remain driven after reset

Version	Date	Changes
v19.08p1p0	November 08, 2019	<ul style="list-style-type: none"> • Fixed erratum in which Debug.SBCS had incorrect reset value for SBACCESS • Fixed typos and other minor documentation errors
v19.08p0	September 17, 2019	<ul style="list-style-type: none"> • The Debug Module memory region is no longer accessible in M-mode
v19.05p2	August 26, 2019	<ul style="list-style-type: none"> • Fix for errata on 7-series cores with L1 data caches or L2 caches in which CFLUSH.D.L1 followed by a load that is nack'd could cause core lockup. • Configuration of standard core parameters updated to match web specification. The cache parameters were updated. I\$ size is now 16 KiB, I\$ associativity is now 2, and L2 size is now 2 MiB.
v19.05p1	July 22, 2019	<ul style="list-style-type: none"> • SiFive Insight is enabled • Fix errata to enable debug halt from first instruction out of reset • Enable debugger reads of Debug Module registers when periphery is in reset • Fix errata to get illegal instruction exception executing DRET outside of debug mode
v19.05	June 09, 2019	<ul style="list-style-type: none"> • v19.05 release of the U74-MC Standard Core. No functional changes.
v19.02	February 28, 2019	<ul style="list-style-type: none"> • Early Access Release of the U74 • Note: The Early Access release of the U74 Standard Core contains a PLIC instead of a CLIC

Contents

1	Introduction	6
1.1	U74-MC Overview.....	6
1.2	S7 RISC-V Monitor Core	7
1.3	U7 RISC-V Application Cores.....	7
1.4	Debug Support	8
1.5	Interrupts	8
2	List of Abbreviations and Terms	9
3	S7 RISC-V Core	11
3.1	Instruction Memory System.....	11
3.2	Instruction-Fetch Unit	12
3.3	Execution Pipeline	13
3.4	Data Memory System.....	14
3.5	Atomic Memory Operations.....	14
3.6	Supported Modes	14
3.7	Physical Memory Protection (PMP).....	14
3.7.1	Functional Description	15
3.7.2	Region Locking	15
3.8	Hardware Performance Monitor.....	15
4	U7 RISC-V Core	17
4.1	Instruction Memory System.....	17
4.2	Instruction-Fetch Unit	18
4.3	Execution Pipeline	19
4.4	Data Memory System.....	20
4.5	Atomic Memory Operations.....	20
4.6	Floating-Point Unit (FPU).....	20
4.7	Virtual Memory Support	20

	2
4.8 Supported Modes	21
4.9 Physical Memory Protection (PMP).....	21
4.9.1 Functional Description	21
4.9.2 Region Locking	22
4.10 Hardware Performance Monitor	22
5 Memory Map	24
6 Interrupts	25
6.1 Interrupt Concepts	25
6.2 Interrupt Operation	26
6.2.1 Interrupt Entry and Exit	26
6.3 Interrupt Control Status Registers.....	27
6.3.1 Machine Status Register (mstatus)	27
6.3.2 Machine Trap Vector (mtvec).....	28
6.3.3 Machine Interrupt Enable (mie)	29
6.3.4 Machine Interrupt Pending (mip)	29
6.3.5 Machine Cause (mcause)	30
6.4 Supervisor Mode Interrupts.....	31
6.4.1 Delegation Registers (mideleg and medeleg)	32
6.4.2 Supervisor Status Register (sstatus).....	33
6.4.3 Supervisor Interrupt Enable Register (sie).....	34
6.4.4 Supervisor Interrupt Pending (sip).....	34
6.4.5 Supervisor Cause Register (scause).....	34
6.4.6 Supervisor Trap Vector (stvec)	35
6.4.7 Delegated Interrupt Handling.....	36
6.5 Interrupt Priorities	37
6.6 Interrupt Latency.....	37
7 Core-Local Interruptor (CLINT).....	38
7.1 CLINT Memory Map.....	38
7.2 MSIP Registers.....	39
7.3 Timer Registers	39

7.4	Supervisor Mode Delegation	39
8	Level 2 Cache Controller	40
8.1	Level 2 Cache Controller Overview.....	40
8.2	Functional Description	40
8.2.1	Way Enable and the L2 Loosely-Integrated Memory (L2 LIM).....	41
8.2.2	Way Masking and Locking.....	42
8.2.3	L2 Zero Device	42
8.2.4	Error Correcting Codes (ECC).....	43
8.3	Memory Map	43
8.4	Register Descriptions	44
8.4.1	Cache Configuration Register (Config).....	45
8.4.2	Way Enable Register (WayEnable)	45
8.4.3	ECC Error Injection Register (ECCInjectError).....	45
8.4.4	ECC Directory Fix Address (DirECCFix*).....	46
8.4.5	ECC Directory Fix Count (DirECCFixCount)	46
8.4.6	ECC Directory Fail Address (DirECCFail*).....	46
8.4.7	ECC Data Fix Address (DatECCFix*).....	46
8.4.8	ECC Data Fix Count (DatECCFixCount)	46
8.4.9	ECC Data Fail Address (DatECCFail*).....	46
8.4.10	ECC Data Fail Count (DatECCFailCount).....	47
8.4.11	Cache Flush Registers (Flush*).....	47
8.4.12	Way Mask Registers (WayMask*)	47
9	Platform-Level Interrupt Controller (PLIC)	49
9.1	Memory Map	49
9.2	Interrupt Sources	53
9.3	Interrupt Priorities	53
9.4	Interrupt Pending Bits.....	54
9.5	Interrupt Enables	54
9.6	Priority Thresholds.....	55
9.7	Interrupt Claim Process	55
9.8	Interrupt Completion.....	56

10 Custom Instructions	57
10.1 CFLASH.D.L1	57
10.2 CDISCARD.D.L1	57
10.3 Other Custom Instructions	58
10.4 SiFive Feature Disable CSR.....	58
11 Debug	59
11.1 Debug CSRs	59
11.1.1 Trace and Debug Register Select (tselect).....	59
11.1.2 Trace and Debug Data Registers (tdata1-3)	60
11.1.3 Debug Control and Status Register (dcsr)	61
11.1.4 Debug PC (dpc).....	61
11.1.5 Debug Scratch (dscratch)	61
11.2 Breakpoints	61
11.2.1 Breakpoint Match Control Register (mcontrol)	61
11.2.2 Breakpoint Match Address Register (maddress).....	63
11.2.3 Breakpoint Execution	63
11.2.4 Sharing Breakpoints Between Debug and Machine Mode	64
11.3 Debug Memory Map.....	64
11.3.1 Debug RAM and Program Buffer (0x300–0x3FF)	64
11.3.2 Debug ROM (0x800–0xFFFF)	64
11.3.3 Debug Flags (0x100–0x110, 0x400–0x7FF)	65
11.3.4 Safe Zero Address.....	65
11.4 Debug Module Interface.....	65
11.4.1 DM Registers	65
11.4.2 Abstract Commands	66
11.4.3 Multi-core Synchronization	66
11.4.4 System Bus Access	66
12 Error Correction Codes (ECC)	67
12.1 ECC Configuration	67
12.1.1 ECC Initialization	67

	5
12.2 ECC Interrupt Handling and Error Injection	68
12.3 Hardware Operation Upon ECC Error	68
13 References	69

Chapter 1

Introduction

SiFive's U74-MC is a full-Linux-capable, cache-coherent 64-bit RISC-V processor available as an IP block. The SiFive U74-MC is guaranteed to be compatible with all applicable RISC-V standards, and this document should be read together with the official RISC-V user-level, privileged, and external debug architecture specifications.



A summary of features in the U74-MC can be found in Table 1.

U74-MC Feature Set	
Feature	Description
Number of Harts	5 Harts.
S7 Core	1× S7 RISC-V core.
U7 Core	4× U7 RISC-V cores.
Level-2 Cache	2 MiB, 8-way L2 Cache.
PLIC Interrupts	127 Interrupt signals which can be connected to off core complex devices.
PLIC Priority Levels	The PLIC supports 7 priority levels.
Hardware Breakpoints	2 hardware breakpoints.
Physical Memory Protection Unit	PMP with 8 x regions and a minimum granularity of 4096 bytes.

Table 1: U74-MC Feature Set

1.1 U74-MC Overview

An overview of the SiFive U74-MC is shown in Figure 1. This RISC-V Core IP includes 5 x 64-bit RISC-V cores, including local and global interrupt support, and physical memory protection. The memory system consists of Data Cache, Data Tightly-Integrated Memory, Instruction

Cache, and Instruction Tightly-Integrated Memory. The U74-MC also includes a debug unit, one incoming Port, and three outgoing Ports.

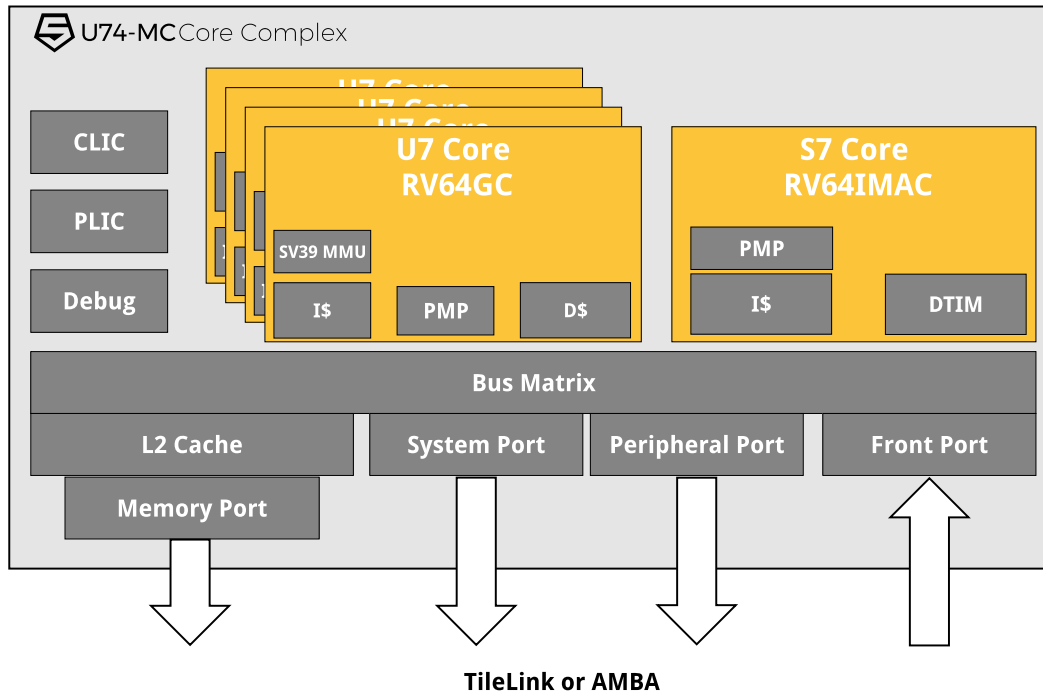

Figure 1: U74-MC Block Diagram

The U74-MC memory map is detailed in Chapter 5, and the interfaces are described in full in the U74-MC User Guide.

1.2 S7 RISC-V Monitor Core

The U74-MC includes a 64-bit S7 RISC-V core, which has a dual-issue, in-order execution pipeline, with a peak execution rate of two instructions per clock cycle. The S7 core supports Machine and User privilege modes, as well as standard Multiply, Atomic, and Compressed RISC-V extensions (RV64IMAC).

The monitor core is described in more detail in Chapter 3.

1.3 U7 RISC-V Application Cores

The U74-MC includes four 64-bit U7 RISC-V cores, which each have a dual-issue, in-order execution pipeline, with a peak execution rate of two instructions per clock cycle. Each U7 core supports Machine, Supervisor, and User privilege modes, as well as standard Multiply, Single-Precision Floating Point, Double-Precision Floating Point, Atomic, and Compressed RISC-V extensions (RV64GC).

The application cores are described in more detail in Chapter 4.

1.4 Debug Support

The U74-MC provides external debugger support over an industry-standard JTAG port, including 2 hardware-programmable breakpoints per hart.

Debug support is described in detail in Chapter 11, and the debug interface is described in the U74-MC User Guide.

1.5 Interrupts

This Core Complex includes a RISC-V standard Platform-Level Interrupt Controller (PLIC), which supports 136 global interrupts with 7 priority levels pre-integrated with the on-core-complex peripherals.

This Core Complex also provides the standard RISC-V machine-mode timer and software interrupts via the Core-Local Interruptor (CLINT).

Interrupts are described in Chapter 6. The CLINT is described in Chapter 7. The PLIC is described in Chapter 9.

Chapter 2

List of Abbreviations and Terms

Term	Definition
BHT	Branch History Table
BTB	Branch Target Buffer
RAS	Return-Address Stack
CLINT	Core-Local Interruptor. Generates per-hart software interrupts and timer interrupts.
CLIC	Core-Local Interrupt Controller. Configures priorities and levels for core local interrupts.
hart	HARdware Thread
DTIM	Data Tightly Integrated Memory
IJTP	Indirect-Jump Target Predictor
ITIM	Instruction Tightly Integrated Memory
JTAG	Joint Test Action Group
LIM	Loosely Integrated Memory. Used to describe memory space delivered in a SiFive Core Complex but not tightly integrated to a CPU core.
PMP	Physical Memory Protection
PLIC	Platform-Level Interrupt Controller. The global interrupt controller in a RISC-V system.
TileLink	A free and open interconnect standard originally developed at UC Berkeley.
RO	Used to describe a Read Only register field.
RW	Used to describe a Read/Write register field.
WO	Used to describe a Write Only registers field.
WARL	Write-Any Read-Legal field. A register field that can be written with any value, but returns only supported values when read.
WIRI	Writes-Ignored, Reads-Ignore field. A read-only register field reserved for future use. Writes to the field are ignored, and reads should ignore the value returned.
WLRL	Write-Legal, Read-Legal field. A register field that should only be written with legal values and that only returns legal value if last written with a legal value.
WPRI	Writes-Preserve Reads-Ignore field. A register field that might contain unknown information. Reads should ignore the value returned, but writes to the whole register should preserve the original value.

Chapter 3

S7 RISC-V Core

This chapter describes the 64-bit S7 RISC-V processor core used in the U74-MC. The S7 processor core comprises an instruction memory system, an instruction fetch unit, an execution pipeline, a data memory system, and support for global, software, and timer interrupts.

The S7 feature set is summarized in Table 2.

Feature	Description
ISA	RV64IMAC.
Instruction Cache	16 KiB 2-way instruction cache.
Data Tightly Integrated Memory	8 KiB DTIM.
ECC Support	Single error correction, double error detection on the Instruction Cache and DTIM.
Modes	The S7 supports the following modes: Machine Mode, User Mode.

Table 2: S7 Feature Set

3.1 Instruction Memory System

The instruction memory system consists of a dedicated 16 KiB 2-way set-associative instruction cache and a 16 KiB Instruction Tightly-Integrated Memory (ITIM). The access latency of all blocks in the instruction memory system is one clock cycle. The instruction cache is not kept coherent with the rest of the platform memory system. Writes to instruction memory must be synchronized with the instruction fetch stream by executing a FENCE.I instruction.

The instruction cache has a line size of 64 bytes, and a cache line fill triggers a burst access outside of the U74-MC. The core caches instructions from executable addresses, with the exception of the ITIM. See the U74-MC Memory Map in Chapter 5 for a description of executable address regions that are denoted by the attribute X.

Trying to execute an instruction from a non-executable address results in a synchronous trap.

3.2 Instruction-Fetch Unit

The S7 instruction-fetch unit (IFU) delivers up to 4 bytes of instructions per clock cycle to support superscalar instruction execution. The IFU contains sophisticated predictive hardware to mitigate the performance impact of control hazards within the instruction stream. The IFU is decoupled from the execution unit, so that correctly predicted control-flow events usually do not result in execution stalls.

- A 16-entry branch target buffer (BTB), which predicts the target of taken branches and direct jumps;
- A 8-entry indirect-jump target predictor (IJTP);
- A 6-entry return-address stack (RAS), which predicts the target of procedure returns;
- A 3.6 KiB branch history table (BHT), which predicts the direction of conditional branches. The BHT is a correlating predictor that supports long branch histories.

The BTB has one-cycle latency, so that correctly predicted branches and direct jumps result in no penalty, provided the target is 4-byte aligned.

Direct jumps that miss in the BTB result in a one-cycle fetch bubble. This event might not result in any execution stalls if the fetch queue is sufficiently full.

The BHT, IJTP, and RAS take precedence over the BTB. If these structures' predictions disagree with the BTB's prediction, a one-cycle fetch bubble results. Similar to direct jumps that miss in the BTB, the fetch bubble might not result in an execution stall.

Mispredicted branches usually incur a four-cycle penalty, but sometimes the branch resolves later in the execution pipeline and incurs a six-cycle penalty instead. Mispredicted indirect jumps incur a six-cycle penalty.

The S7 implements the standard Compressed (C) extension to the RISC-V architecture, which allows for 16-bit RISC-V instructions.

3.3 Execution Pipeline

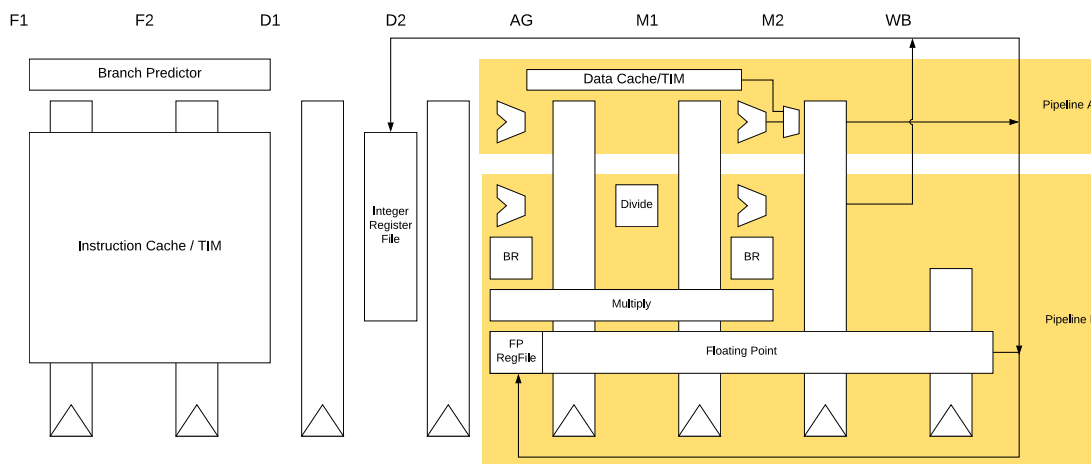

Figure 2: U74-MC Block Diagram

The S7 execution unit is a dual-issue, in-order pipeline. The pipeline comprises eight stages: two stages of instruction fetch (F1 and F2), two stages of instruction decode (D1 and D2), address generation (AG), two stages of data memory access (M1 and M2), and register write-back (WB). The pipeline has a peak execution rate of two instructions per clock cycle, and is fully bypassed so that most instructions have a one-cycle result latency:

- Integer arithmetic and branch instructions can execute in either the AG or M2 pipeline stage. If such an instruction's operands are available when the instruction enters the AG stage, then it executes in AG; otherwise, it executes in M2.
- Loads produce their result in the M2 stage. There is no load-use delay for most integer instructions. However, effective addresses for memory accesses are always computed in the AG stage. Hence, loads, stores, and indirect jumps require their address operands to be ready when the instruction enters AG. If an address-generation operation depends upon a load from memory, then the load-use delay is two cycles.
- Integer multiplication instructions consume their operands in the AG stage and produce their results in the M2 stage. The integer multiplier is fully pipelined.
- Integer division instructions consume their operands in the AG stage. These instructions have between a 3-cycle and 64-cycle result latency, depending on the operand values.
- CSR accesses execute in the M2 stage. CSR read data can be bypassed to most integer instructions with no delay. Most CSR writes flush the pipeline (a seven-cycle penalty).

The pipeline only interlocks on read-after-write and write-after-write hazards, so instructions may be scheduled to avoid stalls.

The pipeline implements a flexible dual-instruction-issue scheme. Provided there are no data hazards between a pair of instructions, the two instructions may issue in the same cycle, provided the following constraints are met:

- At most one instruction accesses data memory;
- At most one instruction is a branch or jump;
- At most one instruction is an integer multiplication or division operation;
- Neither instruction explicitly accesses a CSR.

3.4 Data Memory System

The S7 data memory system consists of a DTIM interface, which supports up to 8 KiB. The access latency from a core to its own DTIM is two clock cycles for full words and three clock cycles for smaller quantities. Memory requests from one core to any other core's DTIM are not as performant as memory requests from a core to its own DTIM. Misaligned accesses are not supported in hardware and result in a trap to allow software emulation.

Stores are pipelined and commit on cycles where the data memory system is otherwise idle. Loads to addresses currently in the store pipeline result in a five-cycle penalty.

3.5 Atomic Memory Operations

The S7 core supports the RISC-V standard Atomic (A) extension on the DTIM and the Peripheral Port. Atomic memory operations to regions that do not support them generate an access exception precisely at the core.

The load-reserved and store-conditional instructions are only supported on cached regions, thus generate an access exception on DTIM and other uncached memory regions.

See *The RISC-V Instruction Set Manual, Volume I: User-Level ISA, Version 2.1* for more information on the instructions added by this extension.

3.6 Supported Modes

The S7 supports RISC-V user mode, providing two levels of privilege: machine (M) and user (U). U-mode provides a mechanism to isolate application processes from each other and from trusted code running in M-mode.

See *The RISC-V Instruction Set Manual, Volume II: Privileged Architecture, Version 1.10* for more information on the privilege modes.

3.7 Physical Memory Protection (PMP)

The S7 includes a Physical Memory Protection (PMP) unit compliant with *The RISC-V Instruction Set Manual, Volume II: Privileged Architecture, Version 1.10*. PMP can be used to set memory access privileges (read, write, execute) for specified memory regions. The S7 PMP supports 8 regions with a minimum region size of 64 bytes.

This section describes how PMP concepts in the RISC-V architecture apply to the S7. The definitive resource for information about the RISC-V PMP is *The RISC-V Instruction Set Manual, Volume II: Privileged Architecture, Version 1.10*.

3.7.1 Functional Description

The S7 includes a PMP unit, which can be used to restrict access to memory and isolate processes from each other.

The S7 PMP unit has 8 regions and a minimum granularity of 64 bytes. Overlapping regions are permitted. The S7 PMP unit implements the architecturally defined `mpcfcfgX` CSR `mpcfcfg0`, supporting 8 regions. `mpcfcfg2` is implemented, but hardwired to zero. Access to `mpcfcfg1` or `mpcfcfg3` results in an illegal instruction exception.

The PMP registers may only be programmed in M-mode. Ordinarily, the PMP unit enforces permissions on U-mode accesses. However, locked regions (see Section 3.7.2) additionally enforce their permissions on M-mode.

3.7.2 Region Locking

The PMP allows for region locking whereby, once a region is locked, further writes to the configuration and address registers are ignored. Locked PMP entries may only be unlocked with a system reset. A region may be locked by setting the L bit in the `mpicfg` register.

In addition to locking the PMP entry, the L bit indicates whether the R/W/X permissions are enforced on M-Mode accesses. When the L bit is clear, the R/W/X permissions apply only to U-mode.

3.8 Hardware Performance Monitor

The U74-MC supports a basic hardware performance monitoring facility compliant with *The RISC-V Instruction Set Manual, Volume II: Privileged Architecture, Version 1.10*. The `mcycle` CSR holds a count of the number of clock cycles the hart has executed since some arbitrary time in the past. The `minstret` CSR holds a count of the number of instructions the hart has retired since some arbitrary time in the past. Both are 64-bit counters.

The hardware performance monitor includes two additional event counters, `mhpmcounter3` and `mhpmcounter4`. The event selector CSRs `mhpmevent3` and `mhpmevent4` are registers that control which event causes the corresponding counter to increment. The `mhpmcounter`s are 40-bit counters.

The event selectors are partitioned into two fields, as shown in Table 3: the lower 8 bits select an event class, and the upper bits form a mask of events in that class. The counter increments if the event corresponding to any set mask bit occurs. For example, if `mhpmevent3` is set to `0x4200`, then `mhpmcounter3` will increment when either a load instruction or a conditional branch instruction retires. An event selector of 0 means "count nothing."

Note that in-flight and recently retired instructions may or may not be reflected when reading or writing the performance counters or writing the event selectors.

Machine Hardware Performance Monitor Event Register	
Instruction Commit Events, mhpeventX[7:0] = 0	
Bits	Meaning
8	Exception taken
9	Integer load instruction retired
10	Integer store instruction retired
11	Atomic memory operation retired
12	System instruction retired
13	Integer arithmetic instruction retired
14	Conditional branch retired
15	JAL instruction retired
16	JALR instruction retired
17	Integer multiplication instruction retired
18	Integer division instruction retired
Microarchitectural Events , mhpeventX[7:0] = 1	
Bits	Meaning
8	Load-use interlock
9	Long-latency interlock
10	CSR read interlock
11	Instruction cache/ITIM busy
12	Data cache/DTIM busy
13	Branch direction misprediction
14	Branch/jump target misprediction
15	Pipeline flush from CSR write
16	Pipeline flush from other event
17	Integer multiplication interlock
Memory System Events, mhpeventX[7:0] = 2	
Bits	Meaning
8	Instruction cache miss
9	Memory-mapped I/O access

Table 3: mhpmevent Register Description

Chapter 4

U7 RISC-V Core

This chapter describes the 64-bit U7 RISC-V processor core used in the U74-MC. The U7 processor core comprises an instruction memory system, an instruction fetch unit, an execution pipeline, a data memory system, a floating-point unit, a memory management unit, and support for global, software, and timer interrupts.

The U7 feature set is summarized in Table 4.

Feature	Description
ISA	RV64GC.
Instruction Cache	32 KiB 8-way instruction cache.
Data Cache	32 KiB 8-way data cache.
ECC Support	Single error correction, double error detection on the Instruction Cache and Data Cache.
Virtual Memory Support	The U7 has support for Sv39 virtual memory support with a 39-bit virtual address space, 38-bit physical address space, and a 40-entry TLB.
Modes	The U7 supports the following modes: Machine Mode, Supervisor Mode, User Mode.

Table 4: U7 Feature Set

4.1 Instruction Memory System

The instruction memory system consists of a dedicated 32 KiB 8-way set-associative instruction cache. The access latency of all blocks in the instruction memory system is one clock cycle. The instruction cache is not kept coherent with the rest of the platform memory system. Writes to instruction memory must be synchronized with the instruction fetch stream by executing a FENCE.I instruction.

The instruction cache has a line size of 64 bytes, and a cache line fill triggers a burst access outside of the U74-MC. The core caches instructions from executable addresses. See the U74-MC Memory Map in Chapter 5 for a description of executable address regions that are denoted by the attribute X.

Trying to execute an instruction from a non-executable address results in a synchronous trap.

4.2 Instruction-Fetch Unit

The U7 instruction-fetch unit (IFU) delivers up to 4 bytes of instructions per clock cycle to support superscalar instruction execution. The IFU contains sophisticated predictive hardware to mitigate the performance impact of control hazards within the instruction stream. The IFU is decoupled from the execution unit, so that correctly predicted control-flow events usually do not result in execution stalls.

- A 16-entry branch target buffer (BTB), which predicts the target of taken branches and direct jumps;
- A 8-entry indirect-jump target predictor (IJTP);
- A 6-entry return-address stack (RAS), which predicts the target of procedure returns;
- A 3.6 KiB branch history table (BHT), which predicts the direction of conditional branches. The BHT is a correlating predictor that supports long branch histories.

The BTB has one-cycle latency, so that correctly predicted branches and direct jumps result in no penalty, provided the target is 4-byte aligned.

Direct jumps that miss in the BTB result in a one-cycle fetch bubble. This event might not result in any execution stalls if the fetch queue is sufficiently full.

The BHT, IJTP, and RAS take precedence over the BTB. If these structures' predictions disagree with the BTB's prediction, a one-cycle fetch bubble results. Similar to direct jumps that miss in the BTB, the fetch bubble might not result in an execution stall.

Mispredicted branches usually incur a four-cycle penalty, but sometimes the branch resolves later in the execution pipeline and incurs a six-cycle penalty instead. Mispredicted indirect jumps incur a six-cycle penalty.

The U7 implements the standard Compressed (C) extension to the RISC-V architecture, which allows for 16-bit RISC-V instructions.

4.3 Execution Pipeline

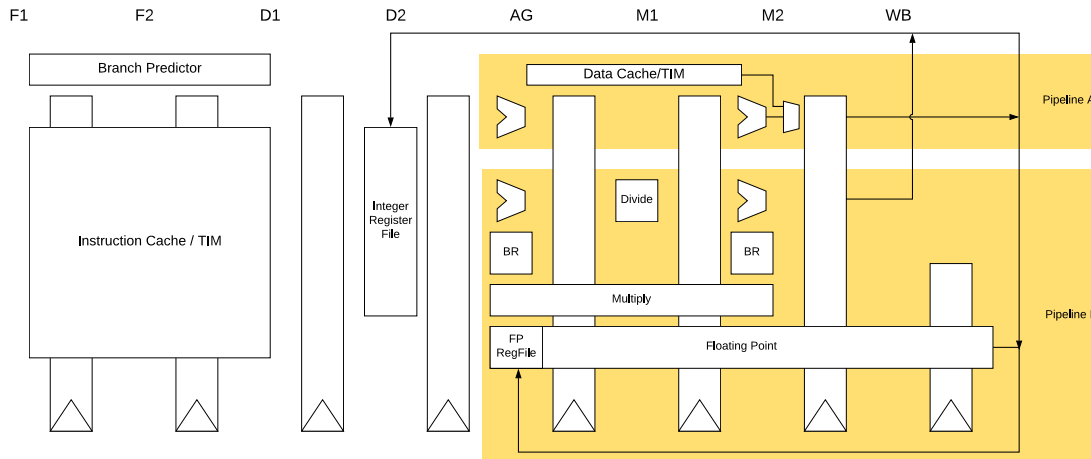

Figure 3: U74-MC Block Diagram

The U7 execution unit is a dual-issue, in-order pipeline. The pipeline comprises eight stages: two stages of instruction fetch (F1 and F2), two stages of instruction decode (D1 and D2), address generation (AG), two stages of data memory access (M1 and M2), and register write-back (WB). The pipeline has a peak execution rate of two instructions per clock cycle, and is fully bypassed so that most instructions have a one-cycle result latency:

- Integer arithmetic and branch instructions can execute in either the AG or M2 pipeline stage. If such an instruction's operands are available when the instruction enters the AG stage, then it executes in AG; otherwise, it executes in M2.
- Loads produce their result in the M2 stage. There is no load-use delay for most integer instructions. However, effective addresses for memory accesses are always computed in the AG stage. Hence, loads, stores, and indirect jumps require their address operands to be ready when the instruction enters AG. If an address-generation operation depends upon a load from memory, then the load-use delay is two cycles.
- Integer multiplication instructions consume their operands in the AG stage and produce their results in the M2 stage. The integer multiplier is fully pipelined.
- Integer division instructions consume their operands in the AG stage. These instructions have between a 3-cycle and 64-cycle result latency, depending on the operand values.
- CSR accesses execute in the M2 stage. CSR read data can be bypassed to most integer instructions with no delay. Most CSR writes flush the pipeline (a seven-cycle penalty).

The pipeline only interlocks on read-after-write and write-after-write hazards, so instructions may be scheduled to avoid stalls.

The pipeline implements a flexible dual-instruction-issue scheme. Provided there are no data hazards between a pair of instructions, the two instructions may issue in the same cycle, provided the following constraints are met:

- At most one instruction accesses data memory;
- At most one instruction is a branch or jump;
- At most one instruction is a floating-point arithmetic operation;
- At most one instruction is an integer multiplication or division operation;
- Neither instruction explicitly accesses a CSR.

4.4 Data Memory System

The U7 data memory system has a 8-way set-associative 32 KiB write-back data cache that supports 64-byte cache lines. The access latency is two clock cycles for words and double-words, and three clock cycles for smaller quantities. Misaligned accesses are not supported in hardware and result in a trap to support software emulation. The data caches are kept coherent with a directory-based cache coherence manager, which resides in the outer L2 cache.

Stores are pipelined and commit on cycles where the data memory system is otherwise idle. Loads to addresses currently in the store pipeline result in a five-cycle penalty.

4.5 Atomic Memory Operations

The U7 core supports the RISC-V standard Atomic (A) extension on the DTIM and the Peripheral Port. Atomic memory operations to regions that do not support them generate an access exception precisely at the core.

The load-reserved and store-conditional instructions are only supported on cached regions, thus generate an access exception on DTIM and other uncached memory regions.

See *The RISC-V Instruction Set Manual, Volume I: User-Level ISA, Version 2.1* for more information on the instructions added by this extension.

4.6 Floating-Point Unit (FPU)

The U7 FPU provides full hardware support for the IEEE 754-2008 floating-point standard for 32-bit single-precision and 64-bit double-precision arithmetic. The FPU includes a fully pipelined fused-multiply-add unit and an iterative divide and square-root unit, magnitude comparators, and float-to-integer conversion units, all with full hardware support for subnormals and all IEEE default values.

4.7 Virtual Memory Support

The U7 has support for virtual memory through the use of a Memory Management Unit (MMU). The MMU supports the Bare and Sv39 modes as described in *The RISC-V Instruction Set Manual, Volume II: Privileged Architecture, Version 1.10*.

The U7 MMU has a 39-bit virtual address space mapped to a 38-bit physical address space. A hardware page-table walker refills the address translation caches. Both first-level instruction and data address translation caches are fully associative and have 40 entries.

The MMU supports 2 MiB megapages and 1 GiB gigapages to reduce translation overheads for large contiguous regions of virtual and physical address space.

Note that the U7 does not automatically set the **Accessed** (A) and **Dirty** (D) bits in a Sv39 Page Table Entry (PTE). Instead, the U7 MMU will raise a page fault exception for a read to a page with PTE.A=0 or a write to a page with PTE.D=0.

4.8 Supported Modes

The U7 supports RISC-V supervisor and user modes, providing three levels of privilege: machine (M), supervisor (S) and user (U). U-mode provides a mechanism to isolate application processes from each other and from trusted code running in M-mode. S-mode adds a number of additional CSRs and capabilities.

See *The RISC-V Instruction Set Manual, Volume II: Privileged Architecture, Version 1.10* for more information on the privilege modes.

4.9 Physical Memory Protection (PMP)

The U7 includes a Physical Memory Protection (PMP) unit compliant with *The RISC-V Instruction Set Manual, Volume II: Privileged Architecture, Version 1.10*. PMP can be used to set memory access privileges (read, write, execute) for specified memory regions. The U7 PMP supports 8 regions with a minimum region size of 4096 bytes.

This section describes how PMP concepts in the RISC-V architecture apply to the U7. The definitive resource for information about the RISC-V PMP is *The RISC-V Instruction Set Manual, Volume II: Privileged Architecture, Version 1.10*.

4.9.1 Functional Description

The U7 includes a PMP unit, which can be used to restrict access to memory and isolate processes from each other.

The U7 PMP unit has 8 regions and a minimum granularity of 4096 bytes. Overlapping regions are permitted. The U7 PMP unit implements the architecturally defined `pmpcfgX` CSR `pmpcfg0`, supporting 8 regions. `pmpcfg2` is implemented, but hardwired to zero. Access to `pmpcfg1` or `pmpcfg3` results in an illegal instruction exception.

The PMP registers may only be programmed in M-mode. Ordinarily, the PMP unit enforces permissions on S-mode and U-mode accesses. However, locked regions (see Section 4.9.2) additionally enforce their permissions on M-mode.

4.9.2 Region Locking

The PMP allows for region locking whereby, once a region is locked, further writes to the configuration and address registers are ignored. Locked PMP entries may only be unlocked with a system reset. A region may be locked by setting the L bit in the `pmpicfg` register.

In addition to locking the PMP entry, the L bit indicates whether the R/W/X permissions are enforced on M-Mode accesses. When the L bit is clear, the R/W/X permissions apply to S-mode and U-mode.

4.10 Hardware Performance Monitor

The U74-MC supports a basic hardware performance monitoring facility compliant with *The RISC-V Instruction Set Manual, Volume II: Privileged Architecture, Version 1.10*. The `mcycle` CSR holds a count of the number of clock cycles the hart has executed since some arbitrary time in the past. The `minstret` CSR holds a count of the number of instructions the hart has retired since some arbitrary time in the past. Both are 64-bit counters.

The hardware performance monitor includes two additional event counters, `mhpmcounter3` and `mhpmcounter4`. The event selector CSRs `mhpmevent3` and `mhpmevent4` are registers that control which event causes the corresponding counter to increment. The `mhpmcounters` are 40-bit counters.

The event selectors are partitioned into two fields, as shown in Table 5: the lower 8 bits select an event class, and the upper bits form a mask of events in that class. The counter increments if the event corresponding to any set mask bit occurs. For example, if `mhpmevent3` is set to `0x4200`, then `mhpmcounter3` will increment when either a load instruction or a conditional branch instruction retires. An event selector of 0 means "count nothing."

Note that in-flight and recently retired instructions may or may not be reflected when reading or writing the performance counters or writing the event selectors.

Machine Hardware Performance Monitor Event Register	
Instruction Commit Events, mhpeventX[7:0] = 0	
Bits	Meaning
8	Exception taken
9	Integer load instruction retired
10	Integer store instruction retired
11	Atomic memory operation retired
12	System instruction retired
13	Integer arithmetic instruction retired
14	Conditional branch retired
15	JAL instruction retired
16	JALR instruction retired
17	Integer multiplication instruction retired
18	Integer division instruction retired
19	Floating-point load instruction retired
20	Floating-point store instruction retired
21	Floating-point addition retired
22	Floating-point multiplication retired
23	Floating-point fused multiply-add retired
24	Floating-point division or square-root retired
25	Other floating-point instruction retired
Microarchitectural Events , mhpeventX[7:0] = 1	
Bits	Meaning
8	Load-use interlock
9	Long-latency interlock
10	CSR read interlock
11	Instruction cache/ITIM busy
12	Data cache/DTIM busy
13	Branch direction misprediction
14	Branch/jump target misprediction
15	Pipeline flush from CSR write
16	Pipeline flush from other event
17	Integer multiplication interlock
18	Floating-point interlock
Memory System Events, mhpeventX[7:0] = 2	
Bits	Meaning
8	Instruction cache miss
9	Data cache miss or memory-mapped I/O access
10	Data cache writeback
11	Instruction TLB miss
12	Data TLB miss

Table 5: mhpevent Register Description

Chapter 5

Memory Map

The memory map of the U74-MC is shown in Table 6.

Base	Top	Attr.	Description
0x0000_0000	0x0000_0FFF	RWX A	Debug
0x0000_1000	0x00FF_FFFF		Reserved
0x0100_0000	0x0100_1FFF	RWX A	DTIM (8 KiB)
0x0100_2000	0x017F_FFFF		Reserved
0x0180_0000	0x0180_3FFF	RWX A	ITIM
0x0180_4000	0x01FF_FFFF		Reserved
0x0200_0000	0x0200_FFFF	RW A	CLINT
0x0201_0000	0x0201_0FFF	RW A	L2 Cache Controller
0x0201_1000	0x07FF_FFFF		Reserved
0x0800_0000	0x081F_FFFF	RWX A	L2 LIM
0x0820_0000	0x0BFF_FFFF		Reserved
0x0C00_0000	0x0FFF_FFFF	RW A	PLIC
0x1000_0000	0x1FFF_FFFF		Reserved
0x2000_0000	0x2FFF_FFFF	RWX A	Peripheral Port (256 MiB)
0x3000_0000	0x3FFF_FFFF		Reserved
0x4000_0000	0x4FFF_FFFF	RWX	System Port (256 MiB)
0x5000_0000	0x7FFF_FFFF		Reserved
0x8000_0000	0x9FFF_FFFF	RWXCA	Memory Port (512 MiB)
0xA000_0000	0xFFFF_FFFF		Reserved

Table 6: U74-MC Memory Map. Memory Attributes: **R** - Read, **W** - Write, **X** - Execute, **C** - Cacheable, **A** - Atomics

Chapter 6

Interrupts

This chapter describes how interrupt concepts in the RISC-V architecture apply to the U74-MC.

The definitive resource for information about the RISC-V interrupt architecture is *The RISC-V Instruction Set Manual, Volume II: Privileged Architecture, Version 1.10*.

6.1 Interrupt Concepts

The U74-MC supports Machine Mode and Supervisor Mode interrupts. It also has support for the following types of RISC-V interrupts: local and global.

Local interrupts are signaled directly to an individual hart with a dedicated interrupt value. This allows for reduced interrupt latency as no arbitration is required to determine which hart will service a given request and no additional memory accesses are required to determine the cause of the interrupt.

Software and timer interrupts are local interrupts generated by the Core-Local Interruptor (CLINT). The U74-MC contains no other local interrupt sources.

Global interrupts, by contrast, are routed through a Platform-Level Interrupt Controller (PLIC), which can direct interrupts to any hart in the system via the external interrupt. Decoupling global interrupts from the harts allow the design of the PLIC to be tailored to the platform, permitting a broad range of attributes like the number of interrupts and the prioritization and routing schemes.

By default, all interrupts are handled in machine mode. For harts that support supervisor mode, it is possible to selectively delegate interrupts to supervisor mode.

This chapter describes the U74-MC interrupt architecture.

Chapter 7 describes the Core-Local Interruptor.

Chapter 9 describes the global interrupt architecture and the PLIC design.

The U74-MC interrupt architecture is depicted in Figure 4.

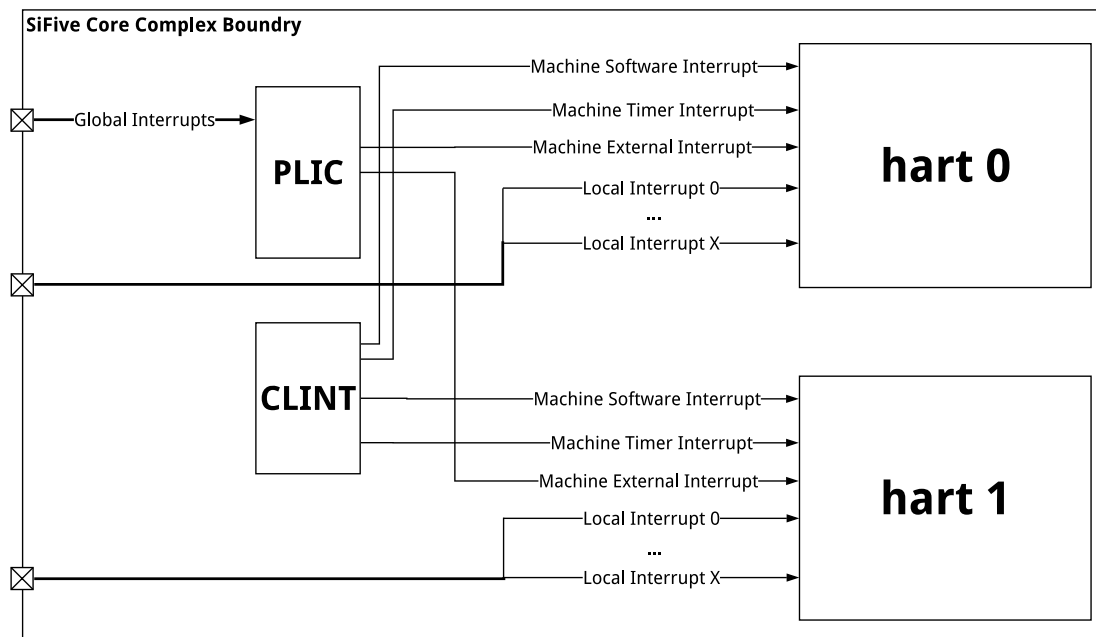

Figure 4: U74-MC Interrupt Architecture Block Diagram

6.2 Interrupt Operation

Within a privilege mode m , if the associated global interrupt-enable $\{ie\}$ is clear, then no interrupts will be taken in that privilege mode, but a pending-enabled interrupt in a higher privilege mode will preempt current execution. If $\{ie\}$ is set, then pending-enabled interrupts at a higher interrupt level in the same privilege mode will preempt current execution and run the interrupt handler for the higher interrupt level.

When an interrupt or synchronous exception is taken, the privilege mode is modified to reflect the new privilege mode. The global interrupt-enable bit of the handler's privilege mode is cleared.

6.2.1 Interrupt Entry and Exit

When an interrupt occurs:

- The value of `mstatus.MIE` is copied into `mcause.MPIE`, and then `mstatus.MIE` is cleared, effectively disabling interrupts.
- The privilege mode prior to the interrupt is encoded in `mstatus.MPP`.
- The current `pc` is copied into the `mepc` register, and then `pc` is set to the value specified by `mtvec` as defined by the `mtvec.MODE` described in Table 9.

At this point, control is handed over to software in the interrupt handler with interrupts disabled. Interrupts can be re-enabled by explicitly setting `mstatus.MIE` or by executing an MRET instruction to exit the handler. When an MRET instruction is executed, the following occurs:

- The privilege mode is set to the value encoded in `mstatus.MPP`.
- The global interrupt enable, `mstatus.MIE`, is set to the value of `mcause.MPIE`.
- The `pc` is set to the value of `mepc`.

At this point control is handed over to software.

The Control and Status Registers involved in handling RISC-V interrupts are described in Section 6.3.

6.3 Interrupt Control Status Registers

The U74-MC specific implementation of interrupt CSRs is described below. For a complete description of RISC-V interrupt behavior and how to access CSRs, please consult *The RISC-V Instruction Set Manual, Volume II: Privileged Architecture, Version 1.10*.

6.3.1 Machine Status Register (`mstatus`)

The `mstatus` register keeps track of and controls the hart's current operating state, including whether or not interrupts are enabled. A summary of the `mstatus` fields related to interrupts in the U74-MC is provided in Table 7. Note that this is not a complete description of `mstatus` as it contains fields unrelated to interrupts. For the full description of `mstatus`, please consult *The RISC-V Instruction Set Manual, Volume II: Privileged Architecture, Version 1.10*.

Machine Status Register			
CSR	mstatus		
Bits	Field Name	Attr.	Description
0	Reserved	WPRI	
1	SIE	RW	Supervisor Interrupt Enable
2	Reserved	WPRI	
3	MIE	RW	Machine Interrupt Enable
4	Reserved	WPRI	
5	SPIE	RW	Supervisor Previous Interrupt Enable
6	Reserved	WPRI	
7	MPIE	RW	Machine Previous Interrupt Enable
8	SPP	RW	Supervisor Previous Privilege Mode
[10:9]	Reserved	WPRI	
[12:11]	MPP	RW	Machine Previous Privilege Mode

Table 7: U74-MC `mstatus` Register (partial)

Interrupts are enabled by setting the MIE bit in `mstatus` and by enabling the desired individual interrupt in the `mie` register, described in Section 6.3.3.

6.3.2 Machine Trap Vector (`mtvec`)

The `mtvec` register has two main functions: defining the base address of the trap vector, and setting the mode by which the U74-MC will process interrupts. For Direct and Vectored modes, the interrupt processing mode is defined in the lower two bits of the `mtvec` register. The `mtvec` register is described in Table 9.

Machine Trap Vector Register			
CSR	mtvec		
Bits	Field Name	Attr.	Description
[1:0]	MODE	WARL	MODE Sets the interrupt processing mode. The encoding for the U74-MC supported modes is described in Table 9.
[63:2]	BASE[63:2]	WARL	Interrupt Vector Base Address. When operating in Direct Mode, requires 4 byte alignment. When operating in Vectored Mode, requires 4 × XLEN byte alignment.

Table 8: `mtvec` Register

MODE Field Encoding <code>mtvec.MODE</code>		
Value	Name	Description
0x0	Direct	All exceptions set <code>pc</code> to <code>BASE</code> .
0x1	Vectored	Asynchronous interrupts set <code>pc</code> to <code>BASE + 4 × mcause.EXCCODE</code> .
≥ 2	Reserved	

Table 9: Encoding of `mtvec.MODE`

See Table 8 for a description of the `mtvec` register. See Table 9 for a description of the `mtvec.MODE` field. See Table 13 for the U74-MC interrupt exception code values.

Mode Direct

When operating in direct mode all synchronous exceptions and asynchronous interrupts trap to the `mtvec.BASE` address. Inside the trap handler, software must read the `mcause` register to determine what triggered the trap.

When operating in Direct Mode, `BASE` must be 4-byte aligned.

Mode Vectored

While operating in vectored mode, interrupts set the `pc` to `mtvec.BASE + 4 × exception code (mcause.EXCCODE)`. For example, if a machine timer interrupt is taken, the `pc` is set to `mtvec.BASE + 0x1C`. Typically, the trap vector table is populated with jump instructions to transfer control to interrupt-specific trap handlers.

In vectored interrupt mode, `BASE` must be $4 \times XLEN$ byte aligned.

All machine external interrupts (global interrupts) are mapped to exception code of 11. Thus, when interrupt vectoring is enabled, the `pc` is set to address `mtvec.BASE + 0x2C` for any global interrupt.

6.3.3 Machine Interrupt Enable (`mie`)

Individual interrupts are enabled by setting the appropriate bit in the `mie` register. The `mie` register is described in Table 10.

Machine Interrupt Enable Register			
CSR	mie		
Bits	Field Name	Attr.	Description
0	Reserved	WPRI	
1	SSIE	RW	Supervisor Software Interrupt Enable
2	Reserved	WPRI	
3	MSIE	RW	Machine Software Interrupt Enable
4	Reserved	WPRI	
5	STIE	RW	Supervisor Timer Interrupt Enable
6	Reserved	WPRI	
7	MTIE	RW	Machine Timer Interrupt Enable
8	Reserved	WPRI	
9	SEIE	RW	Supervisor External Interrupt Enable
10	Reserved	WPRI	
11	MEIE	RW	Machine External Interrupt Enable
[63:12]	Reserved	WPRI	

Table 10: `mie` Register

6.3.4 Machine Interrupt Pending (`mip`)

The machine interrupt pending (`mip`) register indicates which interrupts are currently pending. The `mip` register is described in Table 11.

Machine Interrupt Pending Register			
CSR	mip		
Bits	Field Name	Attr.	Description
0	Reserved	WIRI	
1	SSIP	RW	Supervisor Software Interrupt Pending
2	Reserved	WIRI	
3	MSIP	RO	Machine Software Interrupt Pending
4	Reserved	WIRI	
5	STIP	RW	Supervisor Timer Interrupt Pending
6	Reserved	WIRI	
7	MTIP	RO	Machine Timer Interrupt Pending
8	Reserved	WIRI	
9	SEIP	RW	Supervisor External Interrupt Pending
10	Reserved	WIRI	
11	MEIP	RO	Machine External Interrupt Pending
[63:12]	Reserved	WIRI	

Table 11: mip Register

6.3.5 Machine Cause (mcause)

When a trap is taken in machine mode, `mcause` is written with a code indicating the event that caused the trap. When the event that caused the trap is an interrupt, the most-significant bit of `mcause` is set to 1, and the least-significant bits indicate the interrupt number, using the same encoding as the bit positions in `mip`. For example, a Machine Timer Interrupt causes `mcause` to be set to `0x8000_0000_0000_0007`. `mcause` is also used to indicate the cause of synchronous exceptions, in which case the most-significant bit of `mcause` is set to 0.

See Table 12 for more details about the `mcause` register. Refer to Table 13 for a list of synchronous exception codes.

Machine Cause Register			
CSR	mcause		
Bits	Field Name	Attr.	Description
[9:0]	Exception Code	WLRL	A code identifying the last exception.
[62:10]	Reserved	WLRL	
63	Interrupt	WARL	1 if the trap was caused by an interrupt; 0 otherwise.

Table 12: mcause Register

Interrupt Exception Codes		
Interrupt	Exception Code	Description
1	0	Reserved
1	1	Supervisor software interrupt
1	2	Reserved
1	3	Machine software interrupt
1	4	Reserved
1	5	Supervisor timer interrupt
1	6	Reserved
1	7	Machine timer interrupt
1	8	Reserved
1	9	Supervisor external interrupt
1	10	Reserved
1	11	Machine external interrupt
1	≥ 12	Reserved
0	0	Instruction address misaligned
0	1	Instruction access fault
0	2	Illegal instruction
0	3	Breakpoint
0	4	Load address misaligned
0	5	Load access fault
0	6	Store/AMO address misaligned
0	7	Store/AMO access fault
0	8	Environment call from U-mode
0	9	Environment call from S-mode
0	10	Reserved
0	11	Environment call from M-mode
0	12	Instruction page fault
0	13	Load page fault
0	14	Reserved
0	15	Store/AMO page fault
0	≥ 16	Reserved

Table 13: mcause Exception Codes

6.4 Supervisor Mode Interrupts

The U74-MC supports the ability to selectively direct interrupts and exceptions to supervisor mode, resulting in improved performance by eliminating the need for additional mode changes.

This capability is enabled by the interrupt and exception delegation CSRs; `mideleg` and `medeleg`, respectively. Supervisor interrupts and exceptions can be managed via supervisor versions of the interrupt CSRs, specifically: `stvec`, `sip`, `sie`, and `scause`.

Machine mode software can also directly write to the `sip` register, which effectively sends an interrupt to supervisor mode. This is especially useful for timer and software interrupts as it may be desired to handle these interrupts in both machine mode and supervisor mode.

The delegation and supervisor CSRs are described in the sections below. The definitive resource for information about RISC-V supervisor interrupts is *The RISC-V Instruction Set Manual, Volume II: Privileged Architecture, Version 1.10*.

6.4.1 Delegation Registers (`mideleg` and `medeleg`)

By default, all traps are handled in machine mode. Machine mode software can selectively delegate interrupts and exceptions to supervisor mode by setting the corresponding bits in `mideleg` and `medeleg` CSRs. The exact mapping is provided in Table 14 and Table 15 and matches the `mcause` interrupt and exception codes defined in Table 13.

Note that local interrupts may be delegated to supervisor mode.

Machine Interrupt Delegation Register			
CSR	mideleg		
Bits	Field Name	Attr.	Description
0	Reserved	WARL	
1	SSIP	RW	Delegate Supervisor Software Interrupt
[4:2]	Reserved	WARL	
5	STIP	RW	Delegate Supervisor Timer Interrupt
[8:6]	Reserved	WARL	
9	SEIP	RW	Delegate Supervisor External Interrupt
[63:10]	Reserved	WARL	

Table 14: `mideleg` Register

Machine Exception Delegation Register		
CSR	medeleg	
Bits	Attr.	Description
0	RW	Delegate Instruction Access Misaligned Exception
1	RW	Delegate Instruction Access Fault Exception
2	RW	Delegate Illegal Instruction Exception
3	RW	Delegate Breakpoint Exception
4	RW	Delegate Load Access Misaligned Exception
5	RW	Delegate Load Access Fault Exception
6	RW	Delegate Store/AMO Address Misaligned Exception
7	RW	Delegate Store/AMO Access Fault Exception
8	RW	Delegate Environment Call from U-Mode
9	RW	Delegate Environment Call from S-Mode
[11:0]	WARL	Reserved
12	RW	Delegate Instruction Page Fault
13	RW	Delegate Load Page Fault
14	WARL	Reserved
15	RW	Delegate Store/AMO Page Fault Exception
[63:16]	WARL	Reserved

Table 15: medeleg Register

6.4.2 Supervisor Status Register (sstatus)

Similar to machine mode, supervisor mode has a register dedicated to keeping track of the hart's current state called `sstatus`. `sstatus` is effectively a restricted view of `mstatus`, described in Section 6.3.1, in that changes made to `sstatus` are reflected in `mstatus` and vice-versa, with the exception of the machine mode fields, which are not visible in `sstatus`.

A summary of the `sstatus` fields related to interrupts in the U74-MC is provided in Table 16. Note that this is not a complete description of `sstatus` as it also contains fields unrelated to interrupts. For the full description of `sstatus`, consult the *The RISC-V Instruction Set Manual, Volume II: Privileged Architecture, Version 1.10*.

Supervisor Status Register			
CSR	sstatus		
Bits	Field Name	Attr.	Description
0	Reserved	WPRI	
1	SIE	RW	Supervisor Interrupt Enable
[4:2]	Reserved	WPRI	
5	SPIE	RW	Supervisor Previous Interrupt Enable
[7:6]	Reserved	WPRI	
8	SPP	RW	Supervisor Previous Privilege Mode
[12:9]	Reserved	WPRI	

Table 16: U74-MC `sstatus` Register (partial)

Interrupts are enabled by setting the SIE bit in sstatus and by enabling the desired individual interrupt in the sie register, described in Section 6.4.3.

6.4.3 Supervisor Interrupt Enable Register (sie)

Supervisor interrupts are enabled by setting the appropriate bit in the sie register. The U74-MC sie register is described in Table 17.

Supervisor Interrupt Enable Register			
CSR	sie		
Bits	Field Name	Attr.	Description
0	Reserved	WPRI	
1	SSIE	RW	Supervisor Software Interrupt Enable
[4:2]	Reserved	WPRI	
5	STIE	RW	Supervisor Timer Interrupt Enable
[8:6]	Reserved	WPRI	
9	SEIE	RW	Supervisor External Interrupt Enable
[63:10]	Reserved	WPRI	

Table 17: sie Register

6.4.4 Supervisor Interrupt Pending (sip)

The supervisor interrupt pending (sip) register indicates which interrupts are currently pending. The U74-MC sip register is described in Table 18.

Supervisor Interrupt Pending Register			
CSR	sip		
Bits	Field Name	Attr.	Description
0	Reserved	WIRI	
1	SSIP	RW	Supervisor Software Interrupt Pending
[4:2]	Reserved	WIRI	
5	STIP	RW	Supervisor Timer Interrupt Pending
[8:6]	Reserved	WIRI	
9	SEIP	RW	Supervisor External Interrupt Pending
[63:10]	Reserved	WIRI	

Table 18: sip Register

6.4.5 Supervisor Cause Register (scause)

When a trap is taken in supervisor mode, scause is written with a code indicating the event that caused the trap. When the event that caused the trap is an interrupt, the most-significant bit of scause is set to 1, and the least-significant bits indicate the interrupt number, using the same encoding as the bit positions in sip. For example, a Supervisor Timer Interrupt causes scause to be set to 0x8000_0000_0000_0005.

scause is also used to indicate the cause of synchronous exceptions, in which case the most-significant bit of scause is set to 0. Refer to Table 20 for a list of synchronous exception codes.

Supervisor Cause Register			
CSR	scause		
Bits	Field Name	Attr.	Description
[62:0]	Exception Code (EXCCODE)	WLRL	A code identifying the last exception.
63	Interrupt	WARL	1 if the trap was caused by an interrupt; 0 otherwise.

Table 19: scause Register

Supervisor Interrupt Exception Codes		
Interrupt	Exception Code	Description
1	0	Reserved
1	1	Supervisor software interrupt
1	2 – 4	Reserved
1	5	Supervisor timer interrupt
1	6 – 8	Reserved
1	9	Supervisor external interrupt
1	≥ 10	Reserved
0	0	Instruction address misaligned
0	1	Instruction access fault
0	2	Illegal instruction
0	3	Breakpoint
0	4	Reserved
0	5	Load access fault
0	6	Store/AMO address misaligned
0	7	Store/AMO access fault
0	8	Environment call from U-mode
0	9 – 11	Reserved
0	12	Instruction page fault
0	13	Load page fault
0	14	Reserved
0	15	Store/AMO Page Fault
0	≥ 16	Reserved

Table 20: scause Exception Codes

6.4.6 Supervisor Trap Vector (stvec)

By default, all interrupts trap to a single address defined in the stvec register. It is up to the interrupt handler to read scause and react accordingly. RISC-V and the U74-MC also support the ability to optionally enable interrupt vectors. When vectoring is enabled, each interrupt defined in sie will trap to its own specific interrupt handler.

Vectored interrupts are enabled when the MODE field of the stvec register is set to 1.

Supervisor Trap Vector Register			
CSR	stvec		
Bits	Field Name	Attr.	Description
[1:0]	MODE	WARL	MODE determines whether or not interrupt vectoring is enabled. The encoding for the MODE field is described in Table 22.
[63:2]	BASE[63:2]	WARL	Interrupt Vector Base Address. Must be aligned on a 128-byte boundary when MODE=1. Note, BASE[1:0] is not present in this register and is implicitly 0.

Table 21: stvec Register

MODE Field Encoding stvec.MODE		
Value	Name	Description
0	Direct	All exceptions set pc to BASE
1	Vectored	Asynchronous interrupts set pc to BASE + 4 × scause.EXCCODE
≥ 2	Reserved	

Table 22: Encoding of stvec.MODE

If vectored interrupts are disabled (stvec.MODE=0), all interrupts trap to the stvec.BASE address. If vectored interrupts are enabled (stvec.MODE=1), interrupts set the pc to stvec.BASE + 4 × exception code (scause.EXCCODE). For example, if a supervisor timer interrupt is taken, the pc is set to stvec.BASE + 0x14. Typically, the trap vector table is populated with jump instructions to transfer control to interrupt-specific trap handlers.

In vectored interrupt mode, BASE must be 128-byte aligned.

All supervisor external interrupts (global interrupts) are mapped to exception code of 9. Thus, when interrupt vectoring is enabled, the pc is set to address stvec.BASE + 0x24 for any global interrupt.

See Table 21 for a description of the stvec register. See Table 22 for a description of the stvec.MODE field. See Table 20 for the U74-MC supervisor mode interrupt exception code values.

6.4.7 Delegated Interrupt Handling

Upon taking a delegated trap, the following occurs:

- The value of sstatus.SIE is copied into sstatus.SPIE, then sstatus.SIE is cleared, effectively disabling interrupts.

- The current pc is copied into the sepc register, and then pc is set to the value of stvec. In the case where vectored interrupts are enabled, pc is set to $\text{stvec} . \text{BASE} + 4 \times \text{exception code (scause} . \text{EXCCODE)}$.
- The privilege mode prior to the interrupt is encoded in `sstatus.SPP`.

At this point, control is handed over to software in the interrupt handler with interrupts disabled. Interrupts can be re-enabled by explicitly setting `sstatus.SIE` or by executing an SRET instruction to exit the handler. When an SRET instruction is executed, the following occurs:

- The privilege mode is set to the value encoded in `sstatus.SPP`.
- The value of `sstatus.SPIE` is copied into `sstatus.SIE`.
- The pc is set to the value of sepc.

At this point, control is handed over to software.

6.5 Interrupt Priorities

Individual priorities of global interrupts are determined by the PLIC, as discussed in Chapter 9.

U74-MC interrupts are prioritized as follows, in decreasing order of priority:

- Machine external interrupts
- Machine software interrupts
- Machine timer interrupts
- Supervisor external interrupts
- Supervisor software interrupts
- Supervisor timer interrupts

6.6 Interrupt Latency

Interrupt latency for the U74-MC is 4 cycles, as counted by the number of cycles it takes from signaling of the interrupt to the hart to the first instruction fetch of the handler.

Global interrupts routed through the PLIC incur additional latency of 3 cycles where the PLIC is clocked by `clock`. This means that the total latency, in cycles, for a global interrupt is: $4 + 3 \times (\text{core_clock}_0 \text{ Hz} \div \text{clock Hz})$. This is a best case cycle count and assumes the handler is cached or located in ITIM. It does not take into account additional latency from a peripheral source.

Chapter 7

Core-Local Interruptor (CLINT)

The CLINT block holds memory-mapped control and status registers associated with software and timer interrupts. The U74-MC CLINT complies with *The RISC-V Instruction Set Manual, Volume II: Privileged Architecture, Version 1.10*.

7.1 CLINT Memory Map

Table 23 shows the memory map for CLINT on SiFive U74-MC.

Address	Width	Attr.	Description	Notes
0x0200_0000	4B	RW	msip for hart 0	MSIP Registers (1 bit wide)
0x0200_0004	4B	RW	msip for hart 1	
0x0200_0008	4B	RW	msip for hart 2	
0x0200_000C	4B	RW	msip for hart 3	
0x0200_0010	4B	RW	msip for hart 4	
0x0200_0014			Reserved	
...				
0x0200_3FFF				
0x0200_4000	8B	RW	mtimecmp for hart 0	
0x0200_4008	8B	RW	mtimecmp for hart 1	
0x0200_4010	8B	RW	mtimecmp for hart 2	
0x0200_4018	8B	RW	mtimecmp for hart 3	
0x0200_4020	8B	RW	mtimecmp for hart 4	
0x0200_4028			Reserved	
...				
0x0200_BFF7				
0x0200_BFF8	8B	RW	mtime	Timer Register
0x0200_C000			Reserved	

Table 23: CLINT Register Map

7.2 MSIP Registers

Machine-mode software interrupts are generated by writing to the memory-mapped control register `msip`. Each `msip` register is a 32-bit wide **WARL** register where the upper 31 bits are tied to 0. The least significant bit is reflected in the MSIP bit of the `mip` CSR. Other bits in the `msip` registers are hardwired to zero. On reset, each `msip` register is cleared to zero.

Software interrupts are most useful for interprocessor communication in multi-hart systems, as harts may write each other's `msip` bits to effect interprocessor interrupts.

7.3 Timer Registers

`mtime` is a 64-bit read-write register that contains the number of cycles counted from the `rtc_toggle` signal described in the U74-MC User Guide. A timer interrupt is pending whenever `mtime` is greater than or equal to the value in the `mtimecmp` register. The timer interrupt is reflected in the `mtip` bit of the `mip` register described in Chapter 6.

On reset, `mtime` is cleared to zero. The `mtimecmp` registers are not reset.

7.4 Supervisor Mode Delegation

By default, all interrupts trap to machine mode, including timer and software interrupts. In order for supervisor timer and software interrupts to trap directly to supervisor mode, supervisor timer and software interrupts must first be delegated to supervisor mode.

Please see Section 6.4 for more details on supervisor mode interrupts.

Chapter 8

Level 2 Cache Controller

This chapter describes the functionality of the Level 2 Cache Controller used in the U74-MC.

8.1 Level 2 Cache Controller Overview

The SiFive Level 2 Cache Controller is used to provide access to fast copies of memory for masters in a Core Complex. The Level 2 Cache Controller also acts as a directory-based coherency manager.

The SiFive Level 2 Cache Controller offers extensive flexibility as it allows for several features in addition to the Level 2 Cache functionality. These include memory-mapped access to L2 Cache RAM for disabled cache ways, scratchpad functionality, way masking and locking, ECC support with error tracking statistics, error injection, and interrupt signaling capabilities.

These features are described in Section 8.2.

8.2 Functional Description

The U74-MC L2 Cache Controller is configured into 2 banks. Each bank contains 2048 sets of 8 ways and each way contains a 64-byte block. This subdivision into banks helps facilitate increased available bandwidth between CPU masters and the L2 Cache as each bank has its own dedicated 64-bit TL-C inner port. As such, multiple requests to different banks may proceed in parallel.

The outer port of the L2 Cache Controller is a 128-bit TL-C port shared among all banks and typically connected to a DDR controller. The outer Memory port(s) of the L2 Cache Controller is shared among all banks and typically connected to cacheable memory. The overall organization of the L2 Cache Controller is depicted in Figure 5.

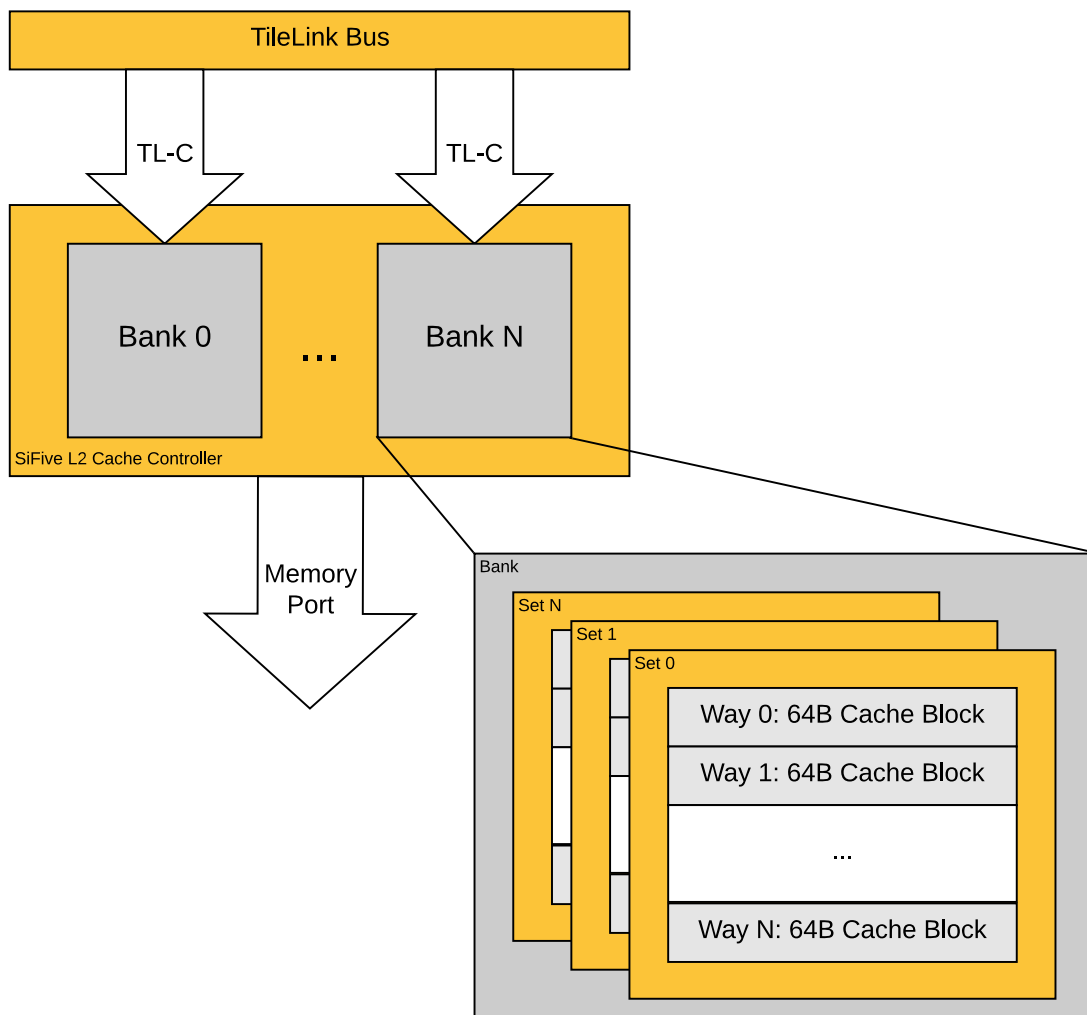

Figure 5: Organization of the SiFive L2 Cache Controller

8.2.1 Way Enable and the L2 Loosely-Integrated Memory (L2 LIM)

Similar to the ITIM discussed in Chapter 4, the SiFive Level 2 Cache Controller allows for its SRAMs to act either as direct addressed memory in the Core Complex address space or as a cache that is controlled by the L2 Cache Controller and which can contain a copy of any cacheable address.

When cache ways are disabled, they are addressable in the L2 Loosely-Integrated Memory (L2 LIM) address space as described in the U74-MC memory map in Chapter 5. Fetching instructions or data from the L2 LIM provides deterministic behavior equivalent to an L2 cache hit, with no possibility of a cache miss. Accesses to L2 LIM are always given priority over cache way accesses, which target the same L2 cache bank.

Out of reset, all ways, except for way 0, are disabled. Cache ways can be enabled by writing to the `wayEnable` register described in Section 8.4.2. Once a cache way is enabled, it cannot be

disabled unless the U74-MC is reset. The highest numbered L2 Cache Way is mapped to the lowest L2 LIM address space, and way 1 occupies the highest L2 LIM address range. As L2 cache ways are enabled, the size of the L2 LIM address space shrinks. The mapping of L2 cache ways to L2 LIM address space is shown in Figure 6.

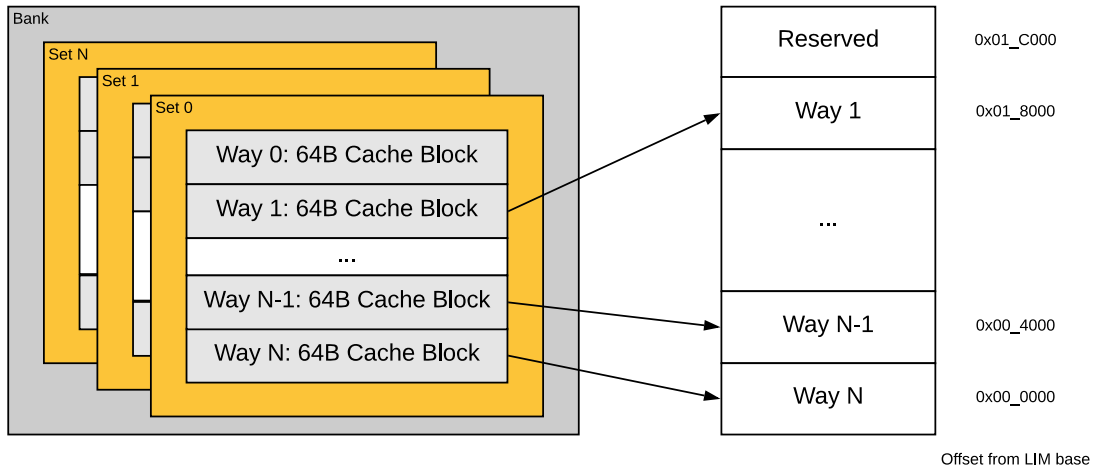

Figure 6: Mapping of L2 Cache Ways to L2 LIM Addresses

8.2.2 Way Masking and Locking

The SiFive L2 Cache Controller can control the amount of cache memory a CPU master is able to allocate into by using the wayMaskX register described in Section 8.4.12. Note that wayMaskX registers only affect allocations, and reads can still occur to ways that are masked. As such, it becomes possible to lock down specific cache ways by masking them in all wayMaskX registers. In this scenario, all masters can still read data in the locked cache ways but cannot evict data.

8.2.3 L2 Zero Device

The SiFive L2 Cache Controller has a dedicated scratchpad address region that allows for allocation into the cache using an address range which is not memory backed. This address region is denoted as the L2 Zero Device in the Memory Map in Chapter 5. Writes to the scratchpad region allocate into cache ways that are enabled and not masked. Care must be taken with the scratchpad, however, as there is no memory backing this address space. Cache evictions from addresses in the scratchpad result in data loss.

The main advantage of the L2 Zero Device over the L2 LIM is that it is a cacheable region allowing for data stored to the scratchpad to also be cached in a master's L1 data cache resulting in faster access.

The recommended procedure for using the L2 Zero Device is as follows:

1. Use the wayEnable register to enable the desired cache ways.

2. Designate a single master that will allocate into the scratchpad. For this procedure, we designate this master as Master S. All other masters (CPU and non-CPU) are denoted as Masters X.
3. Masters X: Write to the wayMaskX register to mask the ways that are to be used for the scratchpad. This prevents Masters X from evicting cache lines in the designated scratchpad ways.
4. Master S: Write to the wayMaskX register to mask all ways *except* the ways that are to be used for the scratchpad. At this point, Master S should only be able to allocate into the cache ways meant to be used as a scratchpad.
5. Master S: Write scratchpad data into the L2 Zero Device address range.
6. Master S: Repeat steps 4 and 5 for each way to be used as scratchpad.
7. Master S: Use the wayMaskX register to mask the scratchpad ways for Master S so that it is no longer able to evict cache lines from the designated scratchpad ways.
8. At this point, the scratchpad ways should contain the scratchpad data, with all masters able to read, write, and execute from this address space, and no masters able to evict the scratchpad contents.

8.2.4 Error Correcting Codes (ECC)

The SiFive Level 2 Cache Controller supports ECC. ECC is applied to both categories of SRAM used, the data SRAMs and the metadata SRAMs (index, tag, and directory information). The data SRAMs use Single-Error Correcting, Double-Error Detecting (SECCDED). The metadata SRAMs use Single-Error Correcting, Double-Error Detecting (SECCDED).

Whenever a correctable error is detected, the cache immediately repairs the corrupted bit and writes it back to SRAM. This corrective procedure is completely invisible to application software. However, to support diagnostics, the cache records the address of the most recently corrected metadata and data errors. Whenever a new error is corrected, a counter is increased and an interrupt is raised. There are independent addresses, counters, and interrupts for correctable metadata and data errors.

DirFail, DirError, DataError, and DataFail signals are used to indicate that an L2 metadata, data, or uncorrectable L2 data error has occurred, respectively. These signals are connected to the PLIC as described in Chapter 9 and are cleared upon reading their respective count registers.

8.3 Memory Map

The L2 Cache Controller memory map is shown in Table 24.

Offset	Name	Description
0x000	Config	Information about the Cache Configuration
0x008	WayEnable	The index of the largest way which has been enabled. May only be increased.
0x040	ECCInjectError	Inject an ECC Error
0x100	DirECCFixLow	The low 32-bits of the most recent address to fail ECC
0x104	DirECCFixHigh	The high 32-bits of the most recent address to fail ECC
0x108	DirECCFixCount	Reports the number of times an ECC error occurred
0x120	DirECCFailLow	The low 32-bits of the most recent address to fail ECC
0x124	DirECCFailHigh	The high 32-bits of the most recent address to fail ECC
0x128	DirECCFailCount	Reports the number of times an ECC error occurred
0x140	DatECCFixLow	The low 32-bits of the most recent address to fail ECC
0x144	DatECCFixHigh	The high 32-bits of the most recent address to fail ECC
0x148	DatECCFixCount	Reports the number of times an ECC error occurred
0x160	DatECCFailLow	The low 32-bits of the most recent address to fail ECC
0x164	DatECCFailHigh	The high 32-bits of the most recent address to fail ECC
0x168	DatECCFailCount	Reports the number of times an ECC error occurred
0x200	Flush64	Flush the physical address equal to the 64-bit written data from the cache
0x240	Flush32	Flush the physical address equal to the 32-bit written data << 4 from the cache
0x800	WayMask0	Master 0 way mask register
0x808	WayMask1	Master 1 way mask register
0x810	WayMask2	Master 2 way mask register
0x818	WayMask3	Master 3 way mask register
0x820	WayMask4	Master 4 way mask register
0x828	WayMask5	Master 5 way mask register
0x830	WayMask6	Master 6 way mask register
0x838	WayMask7	Master 7 way mask register
0x840	WayMask8	Master 8 way mask register
0x848	WayMask9	Master 9 way mask register
0x850	WayMask10	Master 10 way mask register
0x858	WayMask11	Master 11 way mask register
0x860	WayMask12	Master 12 way mask register
0x868	WayMask13	Master 13 way mask register
0x870	WayMask14	Master 14 way mask register

Table 24: Register offsets within the L2 Cache Controller Control Memory Map

8.4 Register Descriptions

This section describes the functionality of the memory-mapped registers in the Level 2 Cache Controller.

8.4.1 Cache Configuration Register (Config)

The Config Register can be used to programmatically determine information regarding the cache size and organization.

Config Register				
Register Offset		0x0		
Bits	Field Name	Attr.	Rst.	Description
[7:0]	Banks	RO	0x2	Number of banks in the cache
[15:8]	Ways	RO	0x8	Number of ways per bank
[23:16]	lgSets	RO	0xB	Base-2 logarithm of the sets per bank
[31:24]	lgBlockBytes	RO	0x6	Base-2 logarithm of the bytes per cache block

Table 25: Information about the Cache Configuration

8.4.2 Way Enable Register (WayEnable)

The WayEnable register determines which ways of the Level 2 Cache Controller are enabled as cache. Cache ways that are not enabled are mapped into the U74-MC's L2 LIM (Loosely-Integrated Memory) as described in the memory map in Chapter 5.

This register is initialized to 0 on reset and may only be increased. This means that, out of reset, only a single L2 cache way is enabled, as one cache way must always remain enabled. Once a cache way is enabled, the only way to map it back into the L2 LIM address space is by a reset.

WayEnable Register				
Register Offset		0x8		
Bits	Field Name	Attr.	Rst.	Description
[7:0]	WayEnable	RW	0x0	The index of the largest way which has been enabled. May only be increased.

Table 26: The index of the largest way which has been enabled. May only be increased.

8.4.3 ECC Error Injection Register (ECCInjectError)

The ECCInjectError register can be used to insert an ECC error into either the backing data or metadata SRAM. This function can be used to test error correction logic, measurement, and recovery.

ECCInjectError Register				
Register Offset		0x40		
Bits	Field Name	Attr.	Rst.	Description
[7:0]	ECCToggleBit	RW	0x0	Toggle (corrupt) this bit index on the next cache operation
[15:8]	Reserved			
16	ECCToggleType	RW	0x0	Toggle (corrupt) a bit in 0=data or 1=directory
[31:17]	Reserved			

Table 27: Inject an ECC Error

8.4.4 ECC Directory Fix Address (DirECCFix*)

The DirECCFixHigh and DirECCFixLow registers are read-only registers that contain the address of the most recently corrected metadata error. This field supplies only the portions of the address that correspond to the affected set and bank, since all ways are corrected together.

8.4.5 ECC Directory Fix Count (DirECCFixCount)

The DirECCFixCount register is a read-only register that contains the number of corrected L2 metadata errors.

Reading this register clears the DirError interrupt signal described in Section 8.2.4.

8.4.6 ECC Directory Fail Address (DirECCFail*)

The DirECCFailLow and DirECCFailHigh registers are read-only registers that contains the address of the most recent uncorrected L2 metadata error.

8.4.7 ECC Data Fix Address (DatECCFix*)

The DatECCFixLow and DatECCFixHigh registers are read-only registers that contain the address of the most recently corrected L2 data error.

8.4.8 ECC Data Fix Count (DatECCFixCount)

The DataECCFixCount register is a read-only register that contains the number of corrected data errors.

Reading this register clears the DataError interrupt signal described in Section 8.2.4.

8.4.9 ECC Data Fail Address (DatECCFail*)

The DatECCFailLow and DatECCFailHigh registers are a read-only registers that contain the address of the most recent uncorrected L2 data error.

8.4.10 ECC Data Fail Count (DatECCFailCount)

The DatECCFailCount register is a read-only register that contains the number of uncorrected data errors.

Reading this register clears the DataFail interrupt signal described in Section 8.2.4.

8.4.11 Cache Flush Registers (Flush*)

The U74-MC L2 Cache Controller provides two registers that can be used for flushing specific cache blocks.

Flush64 is a 64-bit write-only register that flushes the cache block containing the address written. Flush32 is a 32-bit write-only register that flushes a cache block containing the written address left shifted by 4 bytes. In both registers, all bits must be written in a single access for the flush to take effect.

8.4.12 Way Mask Registers (wayMask*)

The wayMaskX register allows a master connected to the L2 Cache Controller to specify which L2 cache ways can be evicted by master X. Masters can still access memory cached in masked ways. The mapping between masters and their L2 master IDs is shown in Table 29.

At least one cache way must be enabled. It is recommended to set/clear bits in this register using atomic operations.

wayMask0 Register				
Register Offset		0x800		
Bits	Field Name	Attr.	Rst.	Description
0	WayMask0[0]	RW	0x1	Enable way 0 for Master 0
1	WayMask0[1]	RW	0x1	Enable way 1 for Master 0
2	WayMask0[2]	RW	0x1	Enable way 2 for Master 0
3	WayMask0[3]	RW	0x1	Enable way 3 for Master 0
4	WayMask0[4]	RW	0x1	Enable way 4 for Master 0
5	WayMask0[5]	RW	0x1	Enable way 5 for Master 0
6	WayMask0[6]	RW	0x1	Enable way 6 for Master 0
7	WayMask0[7]	RW	0x1	Enable way 7 for Master 0

Table 28: Master 0 way mask register

Master ID	Description
0	Hart 0 Fetch Unit
1	Hart 0 D---Cache MMIO
2	Hart 1 Fetch Unit
3	Hart 1 D---Cache
4	Hart 2 Fetch Unit
5	Hart 2 D---Cache
6	Hart 3 Fetch Unit
7	Hart 3 D---Cache
8	Hart 4 Fetch Unit
9	Hart 4 D---Cache
10	Debug
11	AXI4 Front Port ID#0
12	AXI4 Front Port ID#1
13	AXI4 Front Port ID#2
14	AXI4 Front Port ID#3

Table 29: Master IDs in the L2 Cache Controller

Chapter 9

Platform-Level Interrupt Controller (PLIC)

This chapter describes the operation of the platform-level interrupt controller (PLIC) on the U74-MC. The PLIC complies with *The RISC-V Instruction Set Manual, Volume II: Privileged Architecture, Version 1.10* and can support a maximum of 136 external interrupt sources with 7 priority levels.

The U74-MC PLIC resides in the `c1ock` timing domain, allowing for relaxed timing requirements. The latency of global interrupts, as perceived by a hart, increases with the ratio of the `core_clock_0` frequency and the `c1ock` frequency.

9.1 Memory Map

The memory map for the U74-MC PLIC control registers is shown in Table 30. The PLIC memory map only supports aligned 32-bit memory accesses.

PLIC Register Map				
Address	Width	Attr.	Description	Notes
0x0C00_0000			Reserved	
0x0C00_0004	4B	RW	source 1 priority	See Section 9.3 for more information
...				
0x0C00_0220	4B	RW	source 136 priority	
0x0C00_0224			Reserved	
...				
0x0C00_1000	4B	RO	Start of pending array	See Section 9.4 for more information
...				
0x0C00_1010	4B	RO	Last word of pending array	
0x0C00_1014			Reserved	
...				
0x0C00_2000	4B	RW	Start Hart 0 M-Mode interrupt enables	See Section 9.5 for more information
...				
0x0C00_2010	4B	RW	End Hart 0 M-Mode interrupt enables	
0x0C00_2014			Reserved	
...				
0x0C00_2080	4B	RW	Start Hart 1 M-Mode interrupt enables	See Section 9.5 for more information
...				
0x0C00_2090	4B	RW	End Hart 1 M-Mode interrupt enables	
0x0C00_2094			Reserved	
...				
0x0C00_2100	4B	RW	Start Hart 1 S-Mode interrupt enables	See Section 9.5 for more information
...				
0x0C00_2110	4B	RW	End Hart 1 S-Mode interrupt enables	
0x0C00_2114			Reserved	
...				
0x0C00_2180	4B	RW	Start Hart 2 M-Mode interrupt enables	See Section 9.5 for more information
...				
0x0C00_2190	4B	RW	End Hart 2 M-Mode interrupt enables	
0x0C00_2194			Reserved	
...				
0x0C00_2200	4B	RW	Start Hart 2 S-Mode interrupt enables	See Section 9.5 for more information

Table 30: PLIC Register Map

PLIC Register Map				
...				
0x0C00_2210	4B	RW	End Hart 2 S-Mode interrupt enables	
0x0C00_2214			Reserved	
...				
0x0C00_2280	4B	RW	Start Hart 3 M-Mode interrupt enables	See Section 9.5 for more information
...				
0x0C00_2290	4B	RW	End Hart 3 M-Mode interrupt enables	
0x0C00_2294			Reserved	
...				
0x0C00_2300	4B	RW	Start Hart 3 S-Mode interrupt enables	See Section 9.5 for more information
...				
0x0C00_2310	4B	RW	End Hart 3 S-Mode interrupt enables	
0x0C00_2314			Reserved	
...				
0x0C00_2380	4B	RW	Start Hart 4 M-Mode interrupt enables	See Section 9.5 for more information
...				
0x0C00_2390	4B	RW	End Hart 4 M-Mode interrupt enables	
0x0C00_2394			Reserved	
...				
0x0C00_2400	4B	RW	Start Hart 4 S-Mode interrupt enables	See Section 9.5 for more information
...				
0x0C00_2410	4B	RW	End Hart 4 S-Mode interrupt enables	
0x0C00_2414			Reserved	
...				
0x0C20_0000	4B	RW	Hart 0 M-Mode priority threshold	See Section 9.6 for more information
0x0C20_0004	4B	RW	Hart 0 M-Mode claim/complete	See Section 9.7 for more information
0x0C20_0008			Reserved	
...				
0x0C20_1000	4B	RW	Hart 1 M-Mode priority threshold	See Section 9.6 for more information

Table 30: PLIC Register Map

PLIC Register Map				
0x0C20_1004	4B	RW	Hart 1 M-Mode claim/com- plete	See Section 9.7 for more information
0x0C20_1008			Reserved	
...				
0x0C20_2000	4B	RW	Hart 1 S-Mode priority threshold	See Section 9.6 for more information
0x0C20_2004	4B	RW	Hart 1 S-Mode claim/com- plete	See Section 9.7 for more information
0x0C20_2008			Reserved	
...				
0x0C20_3000	4B	RW	Hart 2 M-Mode priority threshold	See Section 9.6 for more information
0x0C20_3004	4B	RW	Hart 2 M-Mode claim/com- plete	See Section 9.7 for more information
0x0C20_3008			Reserved	
...				
0x0C20_4000	4B	RW	Hart 2 S-Mode priority threshold	See Section 9.6 for more information
0x0C20_4004	4B	RW	Hart 2 S-Mode claim/com- plete	See Section 9.7 for more information
0x0C20_4008			Reserved	
...				
0x0C20_5000	4B	RW	Hart 3 M-Mode priority threshold	See Section 9.6 for more information
0x0C20_5004	4B	RW	Hart 3 M-Mode claim/com- plete	See Section 9.7 for more information
0x0C20_5008			Reserved	
...				
0x0C20_6000	4B	RW	Hart 3 S-Mode priority threshold	See Section 9.6 for more information
0x0C20_6004	4B	RW	Hart 3 S-Mode claim/com- plete	See Section 9.7 for more information
0x0C20_6008			Reserved	
...				
0x0C20_7000	4B	RW	Hart 4 M-Mode priority threshold	See Section 9.6 for more information
0x0C20_7004	4B	RW	Hart 4 M-Mode claim/com- plete	See Section 9.7 for more information
0x0C20_7008			Reserved	
...				
0x0C20_8000	4B	RW	Hart 4 S-Mode priority threshold	See Section 9.6 for more information

Table 30: PLIC Register Map

PLIC Register Map				
0x0C20_8004	4B	RW	Hart 4 S-Mode claim/com- plete	See Section 9.7 for more information
0x0C20_8008			Reserved	
...				
0x1000_0000			End of PLIC Memory Map	

Table 30: PLIC Register Map

9.2 Interrupt Sources

The U74-MC has 136 interrupt sources. 127 of these are external global interrupts. The remainder are driven by various on-chip devices as listed in Table 31. These signals are positive-level triggered.

In the PLIC, as specified in *The RISC-V Instruction Set Manual, Volume II: Privileged Architecture, Version 1.10*, Global Interrupt ID 0 is defined to mean "no interrupt," hence `global_interrupts[0]` corresponds to PLIC Interrupt ID 1.

See the U74-MC User Guide for a description of global interrupts.

Source Start	Source End	Source
1	127	External Global Interrupts
128	131	L2 Cache

Table 31: PLIC Interrupt Source Mapping

9.3 Interrupt Priorities

Each PLIC interrupt source can be assigned a priority by writing to its 32-bit memory-mapped priority register. The U74-MC supports 7 levels of priority. A priority value of 0 is reserved to mean "never interrupt" and effectively disables the interrupt. Priority 1 is the lowest active priority, and priority 7 is the highest. Ties between global interrupts of the same priority are broken by the Interrupt ID; interrupts with the lowest ID have the highest effective priority. See Table 32 for the detailed register description.

PLIC Interrupt Priority Register (priority)				
Base Address		0x0C00_0000 + 4 × Interrupt ID		
Bits	Field Name	Attr.	Rst.	Description
[2:0]	Priority	RW	X	Sets the priority for a given global interrupt.
[31:3]	Reserved	RO	0	

Table 32: PLIC Interrupt Priority Register

9.4 Interrupt Pending Bits

The current status of the interrupt source pending bits in the PLIC core can be read from the pending array, organized as 5 words of 32 bits. The pending bit for interrupt ID N is stored in bit $(N \bmod 32)$ of word $(N/32)$. As such, the U74-MC has 5 interrupt pending registers. Bit 0 of word 0, which represents the non-existent interrupt source 0, is hardwired to zero.

A pending bit in the PLIC core can be cleared by setting the associated enable bit then performing a claim as described in Section 9.7.

PLIC Interrupt Pending Register 1 (pending1)				
Base Address		0x0C00_1000		
Bits	Field Name	Attr.	Rst.	Description
0	Interrupt 0 Pending	RO	0	Non-existent global interrupt 0 is hardwired to zero
1	Interrupt 1 Pending	RO	0	Pending bit for global interrupt 1
2	Interrupt 2 Pending	RO	0	Pending bit for global interrupt 2
...				
31	Interrupt 31 Pending	RO	0	Pending bit for global interrupt 31

Table 33: PLIC Interrupt Pending Register 1

PLIC Interrupt Pending Register 5 (pending5)				
Base Address		0x0C00_1010		
Bits	Field Name	Attr.	Rst.	Description
0	Interrupt 128 Pending	RO	0	Pending bit for global interrupt 128
...				
8	Interrupt 136 Pending	RO	0	Pending bit for global interrupt 136
[31:9]	Reserved	WIRI	X	

Table 34: PLIC Interrupt Pending Register 5

9.5 Interrupt Enables

Each global interrupt can be enabled by setting the corresponding bit in the enables registers. The enables registers are accessed as a contiguous array of 5×32 -bit words, packed the same way as the pending bits. Bit 0 of enable word 0 represents the non-existent interrupt ID 0 and is hardwired to 0.

64-bit and 32-bit word accesses are supported by the enables array in SiFive RV64 systems.

PLIC Interrupt Enable Register 1 (enable1) for Hart 0 M-Mode				
Base Address		0x0C00_2000		
Bits	Field Name	Attr.	Rst.	Description
0	Interrupt 0 Enable	RO	0	Non-existent global interrupt 0 is hard-wired to zero
1	Interrupt 1 Enable	RW	X	Enable bit for global interrupt 1
2	Interrupt 2 Enable	RW	X	Enable bit for global interrupt 2
...				
31	Interrupt 31 Enable	RW	X	Enable bit for global interrupt 31

Table 35: PLIC Interrupt Enable Register 1 for Hart 0 M-Mode

PLIC Interrupt Enable Register 5 (enable5) for Hart 4 S-Mode				
Base Address		0x0C00_2410		
Bits	Field Name	Attr.	Rst.	Description
0	Interrupt 128 Enable	RW	X	Enable bit for global interrupt 128
...				
8	Interrupt 136 Enable	RW	X	Enable bit for global interrupt 136
[31:9]	Reserved	RO	0	

Table 36: PLIC Interrupt Enable Register 5 for Hart 4 S-Mode

9.6 Priority Thresholds

The U74-MC supports setting of an interrupt priority threshold via the `threshold` register. The `threshold` is a **WARL** field, where the U74-MC supports a maximum threshold of 7.

The U74-MC masks all PLIC interrupts of a priority less than or equal to `threshold`. For example, a `threshold` value of zero permits all interrupts with non-zero priority, whereas a value of 7 masks all interrupts.

PLIC Interrupt Priority Threshold Register (<code>threshold</code>)				
Base Address		0x0C20_0000		
[2:0]	Threshold	RW	X	Sets the priority threshold
[31:3]	Reserved	RO	0	

Table 37: PLIC Interrupt Threshold Register

9.7 Interrupt Claim Process

A U74-MC hart can perform an interrupt claim by reading the `claim/complete` register (Table 38), which returns the ID of the highest-priority pending interrupt or zero if there is no pending

interrupt. A successful claim also atomically clears the corresponding pending bit on the interrupt source.

A U74-MC hart can perform a claim at any time, even if the MEIP bit in its mip (Table 11) register is not set.

The claim operation is not affected by the setting of the priority threshold register.

9.8 Interrupt Completion

A U74-MC hart signals it has completed executing an interrupt handler by writing the interrupt ID it received from the claim to the claim/complete register (Table 38). The PLIC does not check whether the completion ID is the same as the last claim ID for that target. If the completion ID does not match an interrupt source that is currently enabled for the target, the completion is silently ignored.

PLIC Claim/Complete Register (claim)				
Base Address		0x0C20_0004		
[31:0]	Interrupt Claim/Complete for Hart 0 M-Mode	RW	X	A read of zero indicates that no interrupts are pending. A non-zero read contains the id of the highest pending interrupt. A write to this register signals completion of the interrupt id written.

Table 38: PLIC Interrupt Claim/Complete Register for Hart 0 M-Mode

Chapter 10

Custom Instructions

These custom instructions use the SYSTEM instruction encoding space, which is the same as custom CSR encoding space, but with `funct3=0`.

10.1 `CFLUSH.D.L1`

- Implemented as state machine in L1 D\$, for cores with data caches.
- Only available in M-mode.
- Opcode `0xFC000073`: with optional `rs1` field in bits 19:15.
- When `rs1 = x0`, `CFLUSH.D.L1` writes back and invalidates all lines in the L1 D\$.
- When `rs1 != x0`, `CFLUSH.D.L1` writes back and invalidates the L1 D\$ line containing the virtual address in integer register `rs1`.
- If the effective privilege mode does not have write permissions to the address in `rs1`, then a store access or store page-fault exception is raised.
- If the address in `rs1` is in an uncacheable region with write permissions, the instruction has no effect but raises no exceptions.
- Note that if the PMP scheme write-protects only part of a cache line, then using a value for `rs1` in the write-protected region will cause an exception, whereas using a value for `rs1` in the write-permitted region will write back the entire cache line.

10.2 `CDISCARD.D.L1`

- Implemented as state machine in L1 D\$, for cores with data caches.
- Only available in M-mode.
- Opcode `0xFC200073`: with optional `rs1` field in bits 19:15.
- When `rs1 = x0`, `CDISCARD.D.L1` invalidates, but does not write back, all lines in the L1 D\$. Dirty data within the cache is lost.

- When $rs1 \neq x0$, `CDISCARD.D.L1` invalidates, but does not write back, the L1 D\$ line containing the virtual address in integer register $rs1$. Dirty data within the cache line is lost.
- If the effective privilege mode does not have write permissions to the address in $rs1$, then a store access or store page-fault exception is raised.
- If the address in $rs1$ is in an uncacheable region with write permissions, the instruction has no effect but raises no exceptions.
- Note that if the PMP scheme write-protects only part of a cache line, then using a value for $rs1$ in the write-protected region will cause an exception, whereas using a value for $rs1$ in the write-permitted region will invalidate and discard the entire cache line.

10.3 Other Custom Instructions

Other custom instructions may be implemented, but their functionality is not documented further here and they should not be used in this version of the U74-MC.

10.4 SiFive Feature Disable CSR

SiFive custom M-mode CSRs are provided to enable and disable some microarchitectural features. In the U74-MC CSR 0x7C1 has been allocated for this purpose.

These CSRs are designed such that a zero value in a field indicates the associated feature is fully enabled.

On reset, all dynamic features should be disabled. The boot loader is responsible for turning on all required features, and can simply write zero to the corresponding CSRs to turn on the maximal set of features.

If a particular core does not support dynamic disabling of a feature, the corresponding field is hardwired to zero.

Chapter 11

Debug

This chapter describes the operation of SiFive debug hardware, which follows *The RISC-V Debug Specification, Version 0.13*. Currently only interactive debug and hardware breakpoints are supported.

11.1 Debug CSRs

This section describes the per-hart trace and debug registers (TDRs), which are mapped into the CSR space as follows:

CSR Name	Description	Allowed Access Modes
tselect	Trace and debug register select	D, M
tdata1	First field of selected TDR	D, M
tdata2	Second field of selected TDR	D, M
tdata3	Third field of selected TDR	D, M
dcsr	Debug control and status register	D
dpc	Debug PC	D
dscratch	Debug scratch register	D

Table 39: Debug Control and Status Registers

The dcsr, dpc, and dscratch registers are only accessible in debug mode, while the tselect and tdata1-3 registers are accessible from either debug mode or machine mode.

11.1.1 Trace and Debug Register Select (tselect)

To support a large and variable number of TDRs for tracing and breakpoints, they are accessed through one level of indirection where the tselect register selects which bank of three tdata1-3 registers are accessed via the other three addresses.

The tselect register has the format shown below:

Trace and Debug Select Register			
CSR	tselect		
Bits	Field Name	Attr.	Description
[31:0]	index	WARL	Selection index of trace and debug registers

Table 40: tselect CSR

The index field is a **WARL** field that does not hold indices of unimplemented TDRs. Even if index can hold a TDR index, it does not guarantee the TDR exists. The type field of tdata1 must be inspected to determine whether the TDR exists.

11.1.2 Trace and Debug Data Registers (tdata1-3)

The tdata1-3 registers are XLEN-bit read/write registers selected from a larger underlying bank of TDR registers by the tselect register.

Trace and Debug Data Register 1			
CSR	tdata1		
Bits	Field Name	Attr.	Description
[27:0]	TDR-Specific Data		
[31:28]	type	RO	Type of the trace & debug register selected by tselect

Table 41: tdata1 CSR

Trace and Debug Data Registers 2 and 3			
CSR	tdata2/3		
Bits	Field Name	Attr.	Description
[31:0]	TDR-Specific Data		

Table 42: tdata2/3 CSRs

The high nibble of tdata1 contains a 4-bit type code that is used to identify the type of TDR selected by tselect. The currently defined types are shown below:

Type	Description
0	No such TDR register
1	Reserved
2	Address/Data Match Trigger
≥ 3	Reserved

Table 43: tdata Types

The dmode bit selects between debug mode (dmode=0) and machine mode (dmode=1) views of the registers, where only debug mode code can access the debug mode view of the TDRs. Any

attempt to read/write the `tdata1-3` registers in machine mode when `dmode=1` raises an illegal instruction exception.

11.1.3 Debug Control and Status Register (`dcsr`)

This register gives information about debug capabilities and status. Its detailed functionality is described in *The RISC-V Debug Specification, Version 0.13*.

11.1.4 Debug PC (`dpc`)

When entering debug mode, the current PC is copied here. When leaving debug mode, execution resumes at this PC.

11.1.5 Debug Scratch (`dscratch`)

This register is generally reserved for use by Debug ROM in order to save registers needed by the code in Debug ROM. The debugger may use it as described in *The RISC-V Debug Specification, Version 0.13*.

11.2 Breakpoints

The U74-MC supports two hardware breakpoint registers per hart, which can be flexibly shared between debug mode and machine mode.

When a breakpoint register is selected with `tselect`, the other CSRs access the following information for the selected breakpoint:

CSR Name	Breakpoint Alias	Description
<code>tselect</code>	<code>tselect</code>	Breakpoint selection index
<code>tdata1</code>	<code>mcontrol</code>	Breakpoint match control
<code>tdata2</code>	<code>maddress</code>	Breakpoint match address
<code>tdata3</code>	N/A	Reserved

Table 44: TDR CSRs when used as Breakpoints

11.2.1 Breakpoint Match Control Register (`mcontrol`)

Each breakpoint control register is a read/write register laid out in Table 45.

Breakpoint Control Register (mcontrol)				
Register Offset		CSR		
Bits	Field Name	Attr.	Rst.	Description
0	R	WARL	X	Address match on LOAD
1	W	WARL	X	Address match on STORE
2	X	WARL	X	Address match on Instruction FETCH
3	U	WARL	X	Address match on User Mode
4	S	WARL	X	Address match on Supervisor Mode
5	Reserved	WPRI	X	Reserved
6	M	WARL	X	Address match on Machine Mode
[10:7]	match	WARL	X	Breakpoint Address Match type
11	chain	WARL	0	Chain adjacent conditions.
[15:12]	action	WARL	0	Breakpoint action to take.
[17:16]	szelo	WARL	0	Size of the breakpoint. Always 0.
18	timing	WARL	0	Timing of the breakpoint. Always 0.
19	select	WARL	0	Perform match on address or data. Always 0.
20	Reserved	WPRI	X	Reserved
[26:21]	maskmax	RO	4	Largest supported NAPOT range
27	dmode	RW	0	Debug-Only access mode
[31:28]	type	RO	2	Address/Data match type, always 2

Table 45: Test and Debug Data Register 3

The type field is a 4-bit read-only field holding the value 2 to indicate this is a breakpoint containing address match logic.

The action field is a 4-bit read-write **WARL** field that specifies the available actions when the address match is successful. The value 0 generates a breakpoint exception. The value 1 enters debug mode. Other actions are not implemented.

The R/W/X bits are individual **WARL** fields, and if set, indicate an address match should only be successful for loads/stores/instruction fetches, respectively, and all combinations of implemented bits must be supported.

The M/S/U bits are individual **WARL** fields, and if set, indicate that an address match should only be successful in the machine/supervisor/user modes, respectively, and all combinations of implemented bits must be supported.

The match field is a 4-bit read-write **WARL** field that encodes the type of address range for breakpoint address matching. Three different match settings are currently supported: exact, NAPOT, and arbitrary range. A single breakpoint register supports both exact address matches and matches with address ranges that are naturally aligned powers-of-two (NAPOT) in size. Breakpoint registers can be paired to specify arbitrary exact ranges, with the lower-numbered breakpoint register giving the byte address at the bottom of the range and the higher-numbered

breakpoint register giving the address 1 byte above the breakpoint range, and using the `chain` bit to indicate both must match for the action to be taken.

NAPOT ranges make use of low-order bits of the associated breakpoint address register to encode the size of the range as follows:

address	Match type and size
a...aaaaaa	Exact 1 byte
a...aaaaa0	2-byte NAPOT range
a...aaaa01	4-byte NAPOT range
a...aaa011	8-byte NAPOT range
a...aa0111	16-byte NAPOT range
a...a01111	32-byte NAPOT range
...	...
a01...1111	2^{31} -byte NAPOT range

Table 46: NAPOT Size Encoding

The `maskmax` field is a 6-bit read-only field that specifies the largest supported NAPOT range. The value is the logarithm base 2 of the number of bytes in the largest supported NAPOT range. A value of 0 indicates that only exact address matches are supported (1-byte range). A value of 31 corresponds to the maximum NAPOT range, which is 2^{31} bytes in size. The largest range is encoded in `address` with the 30 least-significant bits set to 1, bit 30 set to 0, and bit 31 holding the only address bit considered in the address comparison.

To provide breakpoints on an exact range, two neighboring breakpoints can be combined with the `chain` bit. The first breakpoint can be set to match on an address using `action` of 2 (greater than or equal). The second breakpoint can be set to match on address using `action` of 3 (less than). Setting the `chain` bit on the first breakpoint prevents the second breakpoint from firing unless they both match.

11.2.2 Breakpoint Match Address Register (`maddress`)

Each breakpoint match address register is an XLEN-bit read/write register used to hold significant address bits for address matching and also the unary-encoded address masking information for NAPOT ranges.

11.2.3 Breakpoint Execution

Breakpoint traps are taken precisely. Implementations that emulate misaligned accesses in software will generate a breakpoint trap when either half of the emulated access falls within the address range. Implementations that support misaligned accesses in hardware must trap if any byte of an access falls within the matching range.

Debug-mode breakpoint traps jump to the debug trap vector without altering machine-mode registers.

Machine-mode breakpoint traps jump to the exception vector with "Breakpoint" set in the `mcause` register and with `badaddr` holding the instruction or data address that caused the trap.

11.2.4 Sharing Breakpoints Between Debug and Machine Mode

When debug mode uses a breakpoint register, it is no longer visible to machine mode (that is, the `tdrtype` will be 0). Typically, a debugger will leave the breakpoints alone until it needs them, either because a user explicitly requested one or because the user is debugging code in ROM.

11.3 Debug Memory Map

This section describes the debug module's memory map when accessed via the regular system interconnect. The debug module is only accessible to debug code running in debug mode on a hart (or via a debug transport module).

11.3.1 Debug RAM and Program Buffer (0x300–0x3FF)

The U74-MC has 16 32-bit words of program buffer for the debugger to direct a hart to execute arbitrary RISC-V code. Its location in memory can be determined by executing `aiupc` instructions and storing the result into the program buffer.

The U74-MC has two 32-bit words of debug data RAM. Its location can be determined by reading the `DMHARTINFO` register as described in the RISC-V Debug Specification. This RAM space is used to pass data for the Access Register abstract command described in the RISC-V Debug Specification. The U74-MC supports only general-purpose register access when harts are halted. All other commands must be implemented by executing from the debug program buffer.

In the U74-MC, both the program buffer and debug data RAM are general-purpose RAM and are mapped contiguously in the Core Complex memory space. Therefore, additional data can be passed in the program buffer, and additional instructions can be stored in the debug data RAM.

Debuggers must not execute program buffer programs that access any debug module memory except defined program buffer and debug data addresses.

The U74-MC does not implement the `DMSTATUS.anyhavereset` or `DMSTATUS.allhavereset` bits.

11.3.2 Debug ROM (0x800–0xFFF)

This ROM region holds the debug routines on SiFive systems. The actual total size may vary between implementations.

11.3.3 Debug Flags (0x100–0x110, 0x400–0x7FF)

The flag registers in the debug module are used for the debug module to communicate with each hart. These flags are set and read used by the debug ROM and should not be accessed by any program buffer code. The specific behavior of the flags is not further documented here.

11.3.4 Safe Zero Address

In the U74-MC, the debug module contains the addresses 0x0 through 0xFFF in the memory map. Memory accesses to these addresses raise access exceptions, unless the hart is in debug mode. This property allows a "safe" location for unprogrammed parts, as the default mtvec location is 0x0.

11.4 Debug Module Interface

The SiFive Debug Module (DM) conforms to *The RISC-V Debug Specification, Version 0.13*. A debug probe or agent connects to the Debug Module through the Debug Module Interface (DMI). The following sections describe notable spec options used in the implementation and should be read in conjunction with the RISC-V Debug Specification.

11.4.1 DM Registers

dmstatus register

dmstatus holds the DM version number and other implementation information. Most importantly, it contains status bits that indicate the current state of the selected hart(s).

dmcontrol register

A debugger performs most hart control through the dmcontrol register.

Control	Function
dmactive	This bit enables the DM and is reflected in the dmactive output signal. When dmactive=0, the clock to the DM is gated off.
ndmreset	This is a read/write bit that drives the ndreset output signal.
resethaltreq	When set, the DM will halt the hart when it emerges from reset.
hartreset	Not Supported
hartsel	This field selects the hart to operate on
hase1	When set, additional hart(s) in the hart array mask register are selected in addition to the one selected by hartsel.

Table 47: Debug Control Register

hawindow register

This register contains a bitmap where bit 0 corresponds to hart 0, bit 1 to hart 1, etc. Any bits set in this register select the corresponding hart in addition to the hart selected by hartsel.

11.4.2 Abstract Commands

Abstract commands provide a debugger with a path to read and write processor state. Many aspects of Abstract Commands are optional in the RISC-V Debug Spec and are implemented as described below.

Cmdtype	Feature	Support
Access Register	GPR registers	Access Register command, register number 0x1000 - 0x101f
	CSR registers	Not supported. CSRs are accessed using the Program Buffer.
	FPU registers	Not supported. FPU registers are accessed using the Program Buffer.
	Autoexec	Both autoexecprogbuf and autoexecdata are supported.
	Post-increment	Not supported.
Quick Access		Not supported.
Access Memory		Not supported. Memory access is accomplished using the Program Buffer.

Table 48: Debug Abstract Commands**11.4.3 Multi-core Synchronization**

The DM is configured with one Halt Group which may be programmed to synchronize execution between harts or between hart(s) and external logic such as a cross-trigger matrix. The Halt Group is configured using the dmcs2 register.

11.4.4 System Bus Access

System Bus Access (SBA) provides an alternative method to access memory. SBA operation conforms to the RISC-V Debug Spec and the description is not duplicated here. Comparing Program Buffer memory access and SBA:

Program Buffer Memory Access	SBA Memory Access
Virtual address	Physical Address
Subject to Physical Memory Protection (PMP)	Not subject to PMP
Cache coherent	Cache coherent
Hart must be halted	Hart may be halted or running

Table 49: System Bus VS Program Buffer Comparison

Chapter 12

Error Correction Codes (ECC)

Error correction codes (ECC) are implemented on various memories within the U74-MC, allowing for the detection and, in some cases, correction of memory errors. The following SRAM blocks on the U74-MC support ECC:

- Instruction Cache
- Data Cache
- L2 Cache

The minimal case of an ECC error is a single bit error that is detected, reported via interrupt handler, and corrected automatically by hardware without any software intervention. More difficult scenarios involve double or multi-bit errors that are still reported and tracked in hardware but are not correctable. The ECC hardware includes logic for detection and correction, in addition to 7 redundant bits per 32-bit codeword or 8 redundant bits per 64-bit codeword.

12.1 ECC Configuration

All blocks with ECC support are enabled globally through the Bus Error Unit (BEU) configuration registers. The BEU is used to configure ECC reporting and enable interrupt handling via the global or local interrupt controller. The global interrupt controller is the Platform-Level Interrupt Controller (PLIC). The local interrupt controller is the Core-Local Interruptor (CLINT). The BEU registers `PLIC_interrupt` and `LOCAL_interrupt` are used to route the errors to the respective interrupt controller. Additionally, the BEU can be used for TileLink bus errors.

12.1.1 ECC Initialization

Any SRAM block or cache memory containing ECC functionality needs to be initialized prior to use. ECC will correct defective bits based on memory contents, so if memory is not first initialized to a known state, then the ECC will not operate as expected. It is recommended to use a DMA, if available, to write the entire SRAM or cache to zeros prior to enabling ECC reporting. If no DMA is present, use store instructions issued from the processor. Initializing memory with

ECC from an external bus is not recommended. After initialization, ECC-related registers can be written to zero, and then ECC reporting can be enabled. 64-bit aligned writes are recommended.

12.2 ECC Interrupt Handling and Error Injection

Single bit errors are automatically repaired by the hardware.

The `plic_interrupt` register indicates which accrued events should generate an interrupt to the PLIC. An interrupt is generated when any bit is set in both accrued and `plic_interrupt`, i.e., when $(\text{accrued} \ \& \ \text{plic_interrupt}) \neq 0$.

The `local_interrupt` register indicates which accrued events should generate an interrupt directly to the hart associated with this Bus Error Unit. An interrupt is generated when any bit is set in both accrued and `local_interrupt`, i.e., when $(\text{accrued} \ \& \ \text{local_interrupt}) \neq 0$.

BEU errors are always enabled and thus do not have a control bit in `mie` (Machine Interrupt Enable) CSR. Likewise, there is no dedicated control bit for BEU errors in the `mideleg` (Machine Interrupt Delegation) CSR, so it cannot be delegated to a lower privilege mode than M-mode.

Monitoring overall ECC events can be accomplished in software via the interrupt handler.

The L2 Cache Controller contains hardware counters to track ECC events, and optionally inject ECC errors to test the software handling of ECC events. The L2 Cache Controller is further described in Chapter 8.

The exception code value is located in the `mcause` (Machine Trap Cause) CSR. When BEU interrupts are routed through the PLIC, the default exception code value will be 11 (0xB). When ECC interrupts are routed through the CLINT, the default exception code value will be 128 (0x80). These exception codes are further detailed in Section 6.3.5.

12.3 Hardware Operation Upon ECC Error

Hardware will operate differently depending on which memory type encounters an ECC error:

- Instruction Cache: The error is corrected and the cache line is flushed.
- Data Cache: The error is corrected and the cache line is invalidated and written back to the next level of memory.
- L2 Cache: Single bit correction for L2 data and metadata (metadata includes index, tag, and directory information). Double bit detection only on the L2 data array.

Double bit errors are reported at the Core Complex boundary via the `halt_from_tile_X` signal that, if asserted, remains high until reset.

Chapter 13

References

Visit the SiFive forums for support and answers to frequently asked questions:
<https://forums.sifive.com>

[1] A. Waterman and K. Asanovic, Eds., The RISC-V Instruction Set Manual, Volume I: User-Level ISA, Version 2.2, June 2019. [Online]. Available: <https://riscv.org/specifications/>

[2] —, The RISC-V Instruction Set Manual Volume II: Privileged Architecture Version 1.11, June 2019. [Online]. Available: <https://riscv.org/specifications/privileged-isa>

[3] —, SiFive TileLink Specification Version 1.8.0, August 2019. [Online]. Available: <https://sifive.com/documentation/tilelink/tilelink-spec>

[4] A. Chang, D. Barbier, and P. Dabbelt, RISC-V Platform-Level Interrupt Controller (PLIC) Specification. [Online]. Available: <https://github.com/riscv/riscv-plic-spec>