

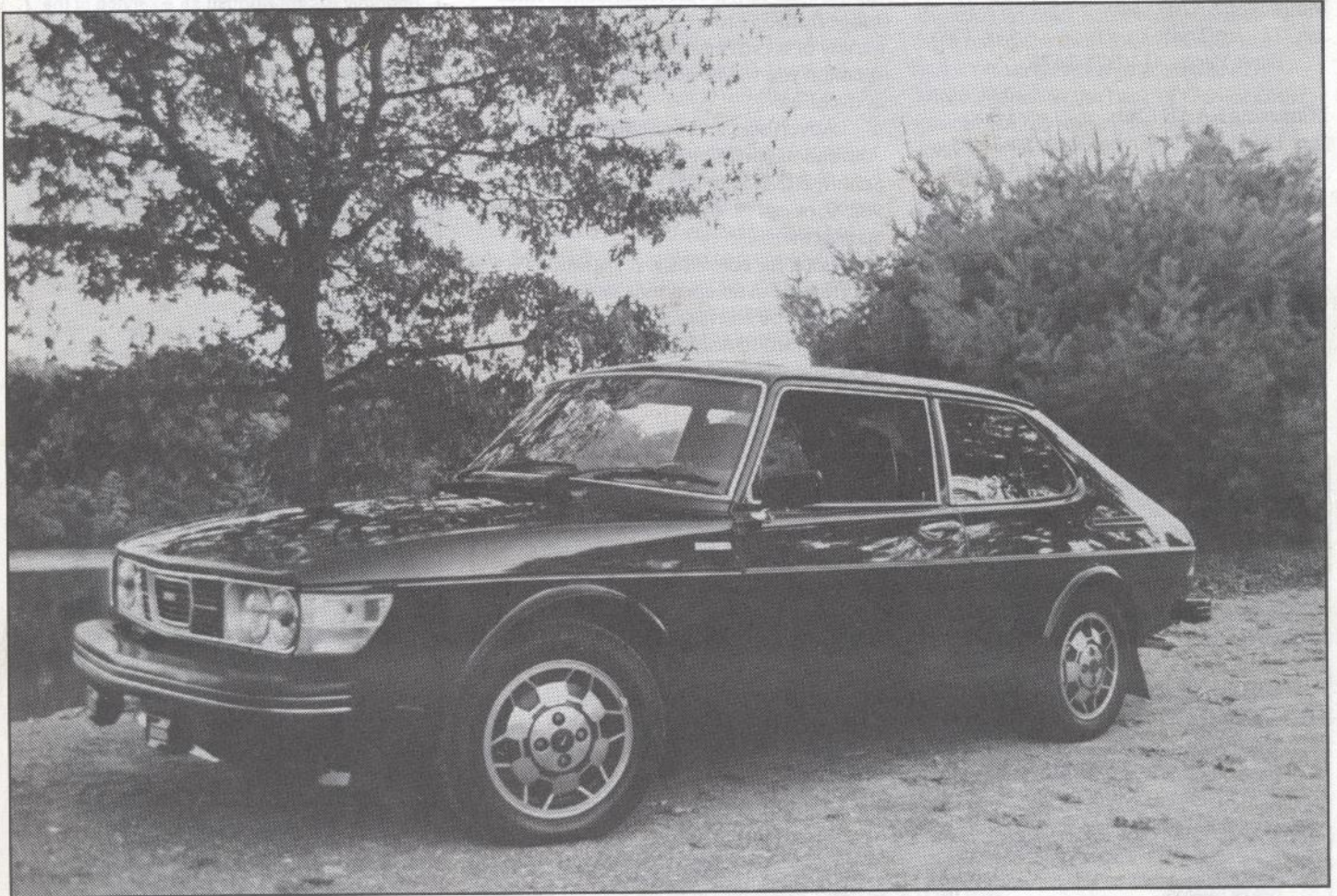

# NINES

THE SAAB CLUB NEWSLETTER

\$2.50  
December  
1990  
no. 198



The Mystery EMS, see page 2

New brake pad recommendation page 6

Tips for saving gasoline page 12

Stereo upgrades pages 18-19

*Behind the wheel of the 9000 Turbo 2.3 in Germany*  
- page 9





# Regional Club News

## Great Lakes SAAB Club

Jan. 19 - Winter Party at the home of Jim and Mary Laman. Dinner, SAAB videos, etc.  
Jim Laman, 616/ 335-5215.

## Milwaukee SAAB Club

Jan. 27 - Ice Trials  
Dave Parps, 414/ 375-2676.

## Minnesota SAAB Club

Jan. 12 - Press-On-Over-Obstacles-Or-Open-Roads Winter Rallye, Duluth.  
Tim Winker, 218/ 724-1336.

## '91 SONG Update

Planning for next summer's SAAB Owners' National Convention to be held August 2-4 at Crystal Mountain Resort near Seattle in Washington state is well along.

Lodging reservations and information may be obtained by contacting Phyllis at Crystal Mountain Resort, P.O. Box 1, Crystal Mountain, Wash. 98022, or calling (206)633-2558 or 1-800-852-1444 (Washington state only). Accommodation rates range from \$53 to \$120 per night for a variety of rooms and suites. Be sure to mention you will be attending the SAAB convention.

Advertisers and exhibitors interested in convention participation should contact Skip Schott, 20220-80th S.E., Snohomish, Wash. 98290, or call (206)486-1351 for details and arrangements.

Look for convention registration information in an upcoming issue of NINES. The Northwest SAAB Owners look forward to hosting a great event in this most dramatic natural setting.

SAAB Club of North America  
2416 London Road, Unit 900  
Duluth, MN 55812-2221

218/ 525-1248, 9am - 6pm Mon - Sat  
Fax number: 218/ 728-6307

NINES Editor & Publisher:  
Tim Winker

Membership / Business Manager  
Marketta Mannoja

NINES is published eleven times a year (monthly except August) as a service of the SAAB Club of North America. The SAAB Club is not affiliated with Saab Cars USA, Inc. or Saab Automobile AB.

All material copyright 1990, SAAB Club of North America. Material may be reproduced with proper credit to the author and to "NINES, the SAAB Club Newsletter". The opinions and views expressed in articles are not necessarily those of the SAAB Club and its newsletter, NINES.

Editorial contributions are welcome. All material submitted is assumed to be for publication unless clearly labeled otherwise. Double-spaced typewritten articles are preferred, but most anything is acceptable. We cannot answer every inquiry and reserve the right to edit materials submitted.

Those wishing to submit articles or letters on 5 1/4" IBM-formatted disks (360K or 1.2 Mb), please convert to ASCII text files (<filename>.TXT). Please include a printed hard copy, and a SASE if you want the disk returned.

**CHANGE OF ADDRESS:** Eight weeks notice is required for change of address. Please send new address and old address, including zip codes, to the SAAB Club at the address above.

**RETURNED CHECKS:** There will be a fee of \$10.00 charged for checks returned for any reason.

## Clubs & Contacts

**Appalachian SAAB Club**  
Stuart Sadikoff  
Route 4, Box 1590  
Sweetwater, TN 37874  
615/ 337-5424.

**SAAB Club of Arizona**  
Meets: 2nd Saturday  
P.O. Box 573  
Scottsdale, AZ 85252  
Steve Bolander, 602/ 946-1865.

**Central Illiana SAAB Club**  
Margrit Adler  
1507 W. University Ave.  
Champaign, IL 61821  
217/ 356-9244.

**Central Penn SAAB Club**  
Meets: 1st Tuesday, Bube's Brewery,  
Mt Joy, PA. Social hour at 6:30pm,  
Meeting at 8:00pm.  
George Basehore  
477 E. Main St.  
Middletown, PA 17057  
717/ 944-2915.

**Central New York SAAB Club**  
Eileen Kolynich  
102 Armstrong Road  
Lansing, NY 14882  
607/ 533-4073.

**Delaware Valley SAAB Club**  
Meets: 2nd Thursday, 7:30pm  
Pat Bolmeyer  
1407 Oak Hill Road  
Wilmington, DE 19805  
302/ 695-3125 or  
302/ 994-6357

**Great Lakes SAAB Club**  
(Western Michigan)  
Jim Laman  
617 Beechwood  
Holland, MI 49423  
616/ 335-5215.

**Milwaukee SAAB Club**  
Meets: 4th Monday, 7:30pm  
Ian Simpson  
3046 N. 46th St.  
Milwaukee, WI 53210  
414/ 873-0818

**Minnesota SAAB Club**  
Meets: 1st Thur, 8pm, Professors,  
HarMar Mall, Roseville, MN.  
Dean Nelson  
612/ 636-3771.

**Montreal SAAB Club**  
E. Peter McLoughlin  
c/o Dormer Laboratories  
6600 Trans Canada Hwy  
Pointe Claire, Quebec H9R 4S2  
514/ 451-5165.

**New England Sonett Club**  
Meets: 1st weekend in March, June,  
Sept. & Dec.  
P.O. Box 4362  
Manchester, NH 03108.

**New Jersey SAAB Club**  
Herb Hirsch  
34 Paul Ave.  
Kendall Park, NJ 08824.  
212/ 730-3835 days  
201/ 821-8284 eves.

**Northern Illinois SAAB Club**  
24 hour Events Hotline:  
312/ 763-4752.

**SAAB Club National Capital Area**  
Meets: at Bethesda Regional Library,  
Bethesda, MD.  
Toby Turpin  
14901 Peach Orchard Rd.  
Silver Spring, MD 20904  
301/ 384-6732.

**SAAB Clubs of Georgia**  
Meets: 1st Monday.  
P.O. Box 52122  
Atlanta, GA 30355-2122

**SAAB Owners Club of Canada, Inc.**  
P.O. Box 578  
Bradford, Ontario L3Z 2B1  
Chris Teixeira, 416/ 737-5827.

**Southern California SAAB Club**  
Paul Florence  
126-1/2 Main St.  
Seal Beach, CA 90740  
213/ 493-6707.

**Tulsa SAAB Club**  
Ray Kurr, 918/ 451-2899.

**Vintage SAAB Club of Washington State**  
Rich Roberts, 206/ 771-7100 days  
Skip Schott, 206/ 486-1351.

**West Mountain SAAB Club**  
(New England/New York)  
David Sullivan  
314 Union Ave.  
Framingham, MA 01701-6319  
508/ 879-8288 after 6pm.

**Western Pennsylvania SAAB Club**  
Andy Bittenbinder  
9433 Katherine Dr.  
Allison Park, PA 15101  
412/ 364-4780.

## Cover - The Mystery EMS

Concours judging at this years convention was done without the owners having to fill out a separate registration. The judge, John Moss of Saab, announced the winners by license plate number. The winning 99 was listed in the September issue as "Unknown - MA lic #232 BAE".

Jeff Becker of Neeham, Mass., has come forward as the owner of the pristine '78 EMS. He writes: "I was forced to leave Sturbridge after the fun Road Rally and could not attend the banquet."

Jeff's EMS "has 58,000 miles and is totally original in all respects including its original Cardinal Red skin."



## Letters to NINES

### We do try

It was with some relief that I read your November issue of NINES magazine and discovered a letter from Mr. Mark Klitzke. It is good to see that both the bad and good come to light in your publication.

It is our philosophy in business as a Saab dealer to do whatever we possibly can to assist our customers with their service and parts needs for the Saab automobile. It is my belief that our staff's efforts are tireless to that end. There are occasions in the service business when one fails to achieve success. At Sports & Specialist Cars, I like to make it my personal business to follow through on those occasions. Kathy Naymola's letter [in the September issue] was especially upsetting because by name she does not appear in any of our service records. This is particularly frustrating as the bulk of her complaints seem to be aimed at another dealer and we appear to be mentioned in a third party fashion. In any event, if she would like to contact us regarding a problem with our dealership, I would be delighted to handle the matter first hand.

In the meantime, good luck with your publication and your club and look forward to our continued participation with your organization.

Rob Burt, President  
Sports & Specialist Cars, Inc.  
Trenton, NJ

### Lemon-Aid

The "Lemon Laws" of the various states are applicable to new motor vehicles and Mel Meer is absolutely correct that liability for a non-conforming vehicle rests with the manufacturer and not the dealer. In fact, the Ohio law specifically excludes the dealer from any liability under the "Lemon Law" section.

Nobody should be subjected to returning a car 23 times for warranty work. To my estimate, 45 states have "Lemon Laws" with various liability thresholds and definitions of "Lemon". Once your car meets that definition, it is presumed your car is a "Lemon".

Ohio, unlike Pennsylvania and

Maryland, is very pro-consumer and only three attempts are allowed the manufacturer (through its dealer) to repair a single non-conformity, not four. Also, the Ohio law mandates refund of the full purchase price (not just invoice) including taxes, interest paid, undercoating and options, and of course, attorney fees may be awarded the consumer. Notice I said the full purchase price with no offset or credit to the manufacturer for depreciation or mileage put on by the consumer, the "Mickey Mouse Mediation" procedure of the Better Business Bureau presently utilized by a large manufacturer.

If in fact Saab is disregarding consumer complaints as alleged by Mr. Meer, it is doing so at its financial peril.

Personally, I have no complaints, but, as a friend of Saab and an owner of Saabs, I hope Saab could better monitor its dealers and service people and nip in the bud warranty problems before they bloom and mature into citrus fruit.

The "Lemon Law" works; believe me!  
Adelbert A. Balunek  
Attorney at Law  
Lorain, OH

### Buying a SAAB in Europe

My first year as a member has been very interesting, helpful and rewarding. I've met terrific people through reader responses, I've learned many helpful technical ideas, I'm more inspired to begin my goal of someday restoring a Sonett, and I'm impressed by your quality work in producing a fine newsletter.

I would like to relate my experience in searching for and purchasing a used SAAB in Europe, which I finally chose to do rather than ship our 900 over there, not knowing if we would be here for nine months or two years. My family and I arranged to arrive in Luxembourg in time for the International SAAB Club Meeting, so I could attend in hopes of easily locating a SAAB. In spite of the relentless jet-lag and a little rain, the beautiful country of Luxembourg was a great choice for us. I attended the banquet held at the Sheraton, plus several informal lunches and a gathering or two of parking lot socials, taking in lots of vintage SAABs and others. There were several very early 92s, a rather hot 99 with a neat 16-valve turbo engine, several excellent examples of

Sonetts and a few "perfect" late (1980) 96s.

But the highlight of my attendance was the chance to meet some really wonderful people, especially the president of the Luxembourg SAAB Club. Jacques Fisch immediately took me under his wing to help locate a car and, even with his broken English, helped translate my needs to others. He even invited my family and me into his home for a barbecue dinner. He also took an hour in his busy schedule to drive me to the local SAAB dealer near his home whom he deals with extensively. There, hidden in the back of *Garage Grun*, was our SAAB waiting for our 3,500 U.S. dollars.

It is a 1982 99GL two-door, Indigo Blue, in near perfect condition with about 73,000 miles on it. It's strictly a European model, with one carburetor, no catalyst, non-operable rear side windows, European headlights with wipers, and rear fog lights. It's a curious combination of the old 99 and later accessories, such as the 900-style bumpers and outside rear-view mirrors, 900-type seats and "H" engine, but only a four-speed with no power options.

We loaded the car down with all our "stuff", drove down through France, across southern Germany to Austria, where we stayed in a small city called Lienz for a few days. Then we drove down to Yugoslavia and on to the south to Skopje. It's good to know we are in a safe, reliable car. Drivers here like to take unnecessary risks all the time, and it's pretty hairy just in everyday driving. At night, there are horse-drawn carts which are very difficult to see, and some drivers don't bother to turn on their headlights. We have to remove the windshield wipers and radio antenna whenever we're away from the car for very long. Apparently these items are in short supply here and tend to disappear quite easily from cars. By the way, the SAAB is quite fancy by Skopje standards.

We plan on driving the SAAB back to the Luxembourg/Belgium area when we're finished here, probably in June of 1991, and try to sell the car before returning to the U.S. In the meantime, I look forward to keeping in touch through NINES.

Ben Bundy  
Skopje, Yugoslavia



## Snigglets

The Snigglet for the universal gesture of greeting oncoming Saabs by flashing your highbeams is quite obvious: SAABLINKING (pronounced *saa-blinking* or *saab-linking*, depending on what part of the country you are from).

When the oncoming Saaber is of the opposite sex: SAABWINKING (only one pronunciation).

What do you call a driver caught in the act of Saabwinking? A SAABWINKER.

Which, of course, begs the question: What is the Snigglet definition of a TIMWINKER?

Tony Gounalis  
Endicott, NY

## Thanks, Mr. Ashcraft

I am the owner of a 1974 green (the best color!) Sonett III equipped with driving lights. In the two years I have owned the car only once for a brief moment did all four lights work correctly. You can imagine the sheer joy when I opened the November issue and found Jack Ashcraft's Sonett III frond end wiring layout. I can finally laugh at the time I got my hand stuck in the opening between the pop-up light and the body. This happened while I was working on the wiring not knowing exactly what wire

went where. (Nice alliteration, eh?)

I'd like to thank Jack Ashcraft for the diagram and all his articles and pictures dealing with Sonetts. I really look forward to all his work printed in NINES, especially that which will save me pain, mental anguish and body parts, both mine and the car's.

Kevin Baumgart  
Cottage Grove, MN

## Warranty cold start fix

During the past summer, I noticed a cold start problem at temperatures above 60°F affecting my 1988 900 8-valve. The engine would fast idle at 1500 RPM, then stall. After several attempts it would idle normally.

My Saab dealer, Brownell Motors in

Fishkill, New York, attempted to find a solution but could not, alluding that all 8-valve 900s experienced this problem. A call to Saab in Connecticut revealed that a factory fix was planned and that my dealer would be notified of the procedure.

The car received new fuel injectors and auxiliary air valve, and mixture and timing adjustments, and now runs perfectly. The entire repair was covered under warranty.

I would advise that all owners of 1988 900s with the 8-valve motor call their dealer and request the above repair, affording easier cold starts in warm weather. I must also congratulate Saab for their prompt attention and rapid repair of my annoying problem.

Andrew Caponi  
Poughkeepsie, NY

## NEW SONNEETT DETAILS!

It is hard to imagine a car more different from the big plastic pig than the new sports car The Factory is going to produce in the St. Louis plant. Due to the limitations of those production facilities, the new Sonneett's body will be fiberglass but otherwise it is as different from the pig as can be imagined.

As mentioned in an earlier column, The Source says that the incredible new car will be mechanically similar to the Monte Carlo Three by Three by Three model. That is the suspension, brakes and the exciting reborn three-speed transmission will be carried over without significant modification. Naturally, the new three speed axle is also part of the package. The Mighty Three engine will be almost identical, triple-intercooled turbo, etc., but to fit under the streamliner's hood, it will have three special carbs. Also because of the hood's rakish angle, the radiator will return to its classic position behind the engine and in front of the firewall. This requires the return of another classic feature of The Factory's cars - an overhead fan shaft.

All this mechanical perfection is going to be wrapped in a super slick new body. The Source flashed various pictures which showed very interesting lines. The hood slopes to the front bumper, the tail is cut off sharply in the current style, and the cabin features fastback styling with the rear window wrapping around from fender to fender. The wheels are to be a very fancy alloy similar to many show cars currently making the rounds. In fact it would be fair to say that the car looks like what it is -- an exotic two passenger grand touring sports car. The Sonneett's greatest strength is that it has impressive engineering; the Mighty Three, the three-speed column shifted transmission, the three-speed axle, free wheel, etc., with the looks and pedigree one usually associates with frivolous boy-toys.

Next time, more engine rumours. Until then, best wishes.

*Simon Du Stroke*

**Exclusive**

**SAAB**

**Parts Center**

The area's most extensive  
inventory at  
competitive discounts

**(215) 886-8660**

Free delivery locally  
or Standard UPS

**SAAB**

**VICTOR**

Exclusively SAAB since 1958

1125-35 Easton Road • Abington, PA 19001  
Facsimile (215) 572-5030



## Doktor Nio's SAAB Klinik

Submit your questions with as complete information on the problem as possible, also giving the year and model of SAAB. Problems of general interest will be answered here. No requests for personal replies please. Questions which would require modification of, or would defeat Federally required emissions systems will not be answered. For a proper diagnosis, it is recommended that you contact an authorized SAAB dealer or repair shop.

Send your questions to: SAAB KLINIK, 2416 London Road, Unit 900, Duluth, MN 55812-2221

I would like to add a CD changer to the trunk of my 1988 9000S, but have been unable to find the pin-out of the signal cable coming off the back of the stock radio.

James DeBruycker  
Nashua NH

*Before I describe where to tap into the Clarion sound system, please allow me to offer a much simpler alternative. The Pioneer model CDX-FM55 CD changer mounts in the trunk and broadcasts through the coaxial antenna lead. It plays back on the FM of your Clarion radio. We've used them with great results. It is a clean installation and sound quality is admirable.*

*If you must tap into the Clarion system, go into the pre-amp signals to the equalizer. They are accessed as follows: Pin #7 (grey, R line-out), and pin #8 (green, L line-out), pin #11 (white/brown, R line-in) and pin #12 (white/red, L line-in). You can then wire a DPDT (double pole-double throw) switch to allow switching between the radio/cassette input or the CD changer input.*

I have a 1982 900 Turbo 3-door with 170,000 miles. For the last 3 to 4 years, the fuel gauge has moved from FULL to EMPTY even though the tank is still half full. The sending unit was replaced with the new, updated version with no improvement.

Lon Herman  
Granville OH

*Saab Service Information 11/83-700 mentions an adapter kit, P/N 85-46-491, to be used in conjunction with the wiring kit for Recall #257. This bulletin is four pages long and rather involved. (It is available by sending \$4.00 to the SAAB Club.)*

*Double check the wiring against the diagram in the bulletin. Test the sender after removing it from the tank and plugging it back into the harness. Lower it into the tank and watch the gauge for changes. A sudden drop in the level sounds more like a fault in the sender or the wiring.*

I own a 1987 9000 Turbo with 63,000 miles on it. My problem is that it starts and runs very rough for the first few minutes. After that it runs well, but when slowing

down from any type of high RPMs, it dips down to about 500 RPM and gives serious consideration to stalling. Can I fix this myself cheaply?

Chris Harris  
Yucaipa CA

*The best advice I can offer is to insure that all vacuum hoses and inlet pipes are attached and not leaking. Be sure to check for cracks and loose hose clamps.*

*Remove the AIC (automatic idle control) valve and check the shutter for free movement when quickly rotated by hand. Using a de-varnish carb cleaner, clean the shutter area and re-check for smooth shutter operation. The valve is clamped at the center of the intake manifold, and has one large electrical plug and two rubber hoses connected to it.*

*Next, thoroughly clean the throttle throat and butterfly after removing the intake hose. Ensure that the hoses leading from the AIC valve to the throttle body are cleaned, too.*

*If the problem persists, have a Saab technician check the basic idle and set it. Be sure he checks the throttle switch adjustment before he's finished. He may tell you a new AIC valve is needed, but it won't cost you thousands of dollars.*

There is very little clutch upon initial start-up in my 1989 9000 Turbo (17,000 miles) if the car has been sitting eight hours or more. After a few miles, the clutch becomes progressively better. By the time I drive to the dealer (16 miles) the clutch is good enough for them to claim "no problem found." Lately the problem has been getting worse, but still clears up enough to fool the dealer. I'm not enthused about leaving the car overnight at the dealer unless I have no other choice.

Robert Lomitola  
Cocoa FL

*I have experienced a soft clutch pedal on both of my 9000s, one an "S", the other a Turbo. Neither car had over 6,000 miles when this occurred. By pressure bleeding the slave cylinder and refilling with Castrol LMA brake fluid, the problems disappeared. Be sure you have flushed all the old fluid out.*

How do I know if my 1987 900S with 53,000 highway miles needs new shock absorbers? My tires seem to be wearing evenly, and since the factory-installed gas shocks are firm, bouncing the corners of the car does not tell me anything.

I'm happy with the ride, so am I worrying over nothing?

Aavo Harju  
Somerset NJ

*The OE gas shocks are of very high quality. As long as there is no evidence of fluid leakage, the shock is probably fine. Gas shocks seem to work consistently until they either seize or blow-out, that is lose all their damping power. You may be worried over nothing. Put a new set on before your Saab hits 100,000 miles, just to be on the safe side.*

At 116,000 miles, my 1981 900S 5-speed developed an occasional misfire which worsened over a few days to barely driveable. It would start and run fine until it was warmed up. As all ignition parts except plugs were original, I replaced plugs, HT wires, cap and rotor, with no improvement. I also checked most of the electrical components, even disconnected the oxygen sensor. Still no improvement. As the problem was temperature related, I disconnected the electrical plug of the warm-up regulator. Almost instantly the car settled down and ran smoothly. It now starts and runs fine, cold or warm. If I reconnect this plug, power loss and missing resume. What's up Dok?

Wes Verkaart  
Duxbury MA

*Once the warm-up regulator is disconnected, the mixture will begin to richen up as with a cold engine. Since the problem seems to go away with a richer than normal control pressure, there may be a vacuum leak causing the lean mixture. It may be best to begin with a test of fuel pressure values, line and control pressures. You'll need a special pressure gauge and valve to perform these tests. The fuel pump could be worn enough that line pressure slowly drops as the pump heats up and loses efficiency.*



# SERVICE SUBJECTS



## FROM SAAB

### Brake Pad Recommendations

Application: 1988-on 900 models,  
1986-on 9000 models

PSI 08/90-0017, S-5/P.1

Supersedes: S.I. 07/87-986

The primary front brake pad recommendation for 1987-89 9000 naturally aspirated, 1986-87 9000 Turbo models and all 1988-on 900 models has been changed to a DM 127 composition pad set. These new pads, P/N 41 07 116, provide the best available combination of pad/rotor wear and

performance characteristics.

For 1990-on 9000 naturally aspirated models, and 1988-on 9000 Turbo models, the front brake pad set remains the Textar

474 set (P/N 89 68 976).

The recommended rear pads for 1988-on 900 models and all 9000 models remains P/N 89 68 026.

### Brake Pad Application Chart

900 1988-, 9000 1986-

Application	Lining I.D.	Part Number	Remarks
<b>Front Brake Pads*</b>			
900 1988- All models 9000 1987-89 Naturally-aspirated 9000 1986-87 Turbo	DM 127	41 07 116**	Primary recommendation.
900 1988- All models 9000 1987-89 Naturally-aspirated 9000 1986-87 Turbo	TEXTAR 474	89 68 018	Superseded by 41 07 116.
9000 1990- Naturally-aspirated 9000 1988- Turbo	TEXTAR 474	89 68 976	
<b>Rear Brake Pads*</b>			
900 1988- All models 9000 1986- All models	DB 870	89 68 026	

\* All brake pads supplied by Saab are asbestos free.

\*\* These pads may require greater pedal effort to be used, particularly on cars with ABS brakes. DM 127 front pads were introduced into 900 production as from VIN's: L3007005-, L5002289-, L7018796-.

Orders Only \$25.00 Minimum 1-800-999-1820 MC/Visa/Amex		<b>IMPORT MOTOR PARTS</b>		Information & Technical Help 1-719-542-7025	
		110 WEST 12TH ST., PUEBLO, CO 81003 ** Same Day Shipping **			
<b>BOSCH ALTERNATORS (EXCHANGED)</b>					
AL35X	78-83 Turbo & 81-83 900s	162.25			
AL36X	5/78-80 99 Non Turbo	147.35			
AL69X	85-86 900T, 86 9000 Turbo	204.95			
AL95X	67-74 95, 96, Sonett	68.15			
AL96X	74-4/78 99	102.25			
AL112X	79-80 900 Non Turbo	103.35			
AL128X	84-85 900 Non Turbo	186.95			
<b>BOSCH FUEL PUMPS</b>					
GFP202	82-86 900, 82-84 Turbo	225.06			
GFP213	75-81 99, 900, & Turbo	169.95			
GFP270	69-74 99E, 99 EMS	135.86			
GFP288	1985 900 Turbo 16V	143.88			
GFP294	86 900 16v, 9000 Turbo	167.04			
<b>BOSCH STARTERS (EXCHANGED)</b>					
SR32X	85-87 900, 9000 & Turbos	214.45			
SR77X	70-74 99	86.30			
SR78X	75-84 99, 900 & Turbos	93.45			
SR79X	69-73 95, 96 & 71-74 Sonett	83.55			
SR80X	67-68 95, 96 & 68-70 Sonett	87.95			
<b>IGNITION CONTROL UNITS</b>					
00014	99, 900 78-81	232.13			
00139	900 82-84	109.01			
<b>BOSCH LAMBDA SENSORS</b>					
01051	77-86 1 Wire	38.95			
03006	86 900 16V	112.46			
03009	84-4/85 900 Turbo 16V	134.33			
03028	5/85-on All Turbo 16V	144.07			
<b>BOSCH IDLE SPEED REGULATORS</b>					
40502	85-86 16V	134.94			
<b>BOSCH FUEL INJECTORS</b>					
50045	71-74 99 All 1.7, 2.0	35.62			
02004	75-80 99, 900 Exc 78 99T	20.81			
02012	81-86 900 All 8 Valve	22.50			
<b>BOSCH COLD START VALVES</b>					
70401	75-80 All	35.94			
70406	81-86 All 8 Valve	42.69			
<b>CONSTANT VELOCITY JOINTS</b>					
8921728	75-80 99, 900 Outer Jnt	137.95			
8942633	81-85 900 Outer Joint	137.95			
8945735	69-84 All Inner Tripod	49.95			
<b>BOSCH WARMUP REGULATORS</b>					
40013	1975 99 All	134.94			
40020	76-80 99, 900 Non Tbo	85.86			
40032	76-80 99, 900 Calif cars	106.22			
40051	78-80 All Tbos.	106.22			
40084	81-83 900 & Tbos.	179.95			
40136	84-86 900 & Tbos.	110.82			
<b>BOSCH FILTERS</b>					
05005	Fuel 75-77 99	14.57			
05021	Fuel 78-79 99, 900 & Tbos	10.96			
05401	Fuel 80-4/85 900, Turbo	15.12			
05601	Fuel 5/85-86 900, 16V, & Tbo	16.58			
72101	Oil 67-88 Saab All	3.71			
73228	Air 75-86 2.0 exc 16V	5.50			
<b>BOSCH MISCELLANEOUS ITEMS</b>					
00044	12 Volt Universal	14.23			
03010	Dist Cap - Most Saabs	5.18			
04038	Rotor 78-80 99, 900 Tbo.	4.55			
04125	Rotor 1981 900, Turbo	6.27			
04144	Rotor 82-85 900T; 82-87 900	9.52			
04168	Rotor 1985 900	7.80			
09105	Wires 72-80 All 99s, 900s	12.95			
09106	Wires 81-87 900, 900 Turbos	12.95			
<b>TIMING BELTS &amp; PIECES</b>					
7500697	Chain 85on 16Vs	28.69			
7871403	Chain 73-80 99, 900	29.75			
8346785	Crank Gear 73-80 99, 900	37.95			
8346793	Idler Gear 73-80 99, 900	34.95			
8346801	Cam Gear 73-80 99, 900	41.25			
8347874	Tensioner 73-80 99, 900	26.65			
8817405	Tensioner 81-88 900 8V	19.98			
9359779	Chain 81-88 900 8V	19.98			
<b>COUNTERSHAFT</b>					
8358509	73-80 99; 79-80 900 2.0	225.00			
<b>RADIATORS &amp; WATER PUMPS</b>					
7540503	Radiator 1977-80 99s	175.00			
7541063	Radiator 79on 900s	179.95			
7541071	Radiator 79on 900 Tbo	169.95			
8358491	Pump 75-76 99 12 Cog	69.95			
8367674	Pump 77-80 99, 900 (Kit)	79.95			
8389058	Pump 69-76 99 (Kit)	32.95			
8389751	Radiator 69-76 99s	189.95			
8814591	Pump 67-74 95, 96, Sonett	29.95			
8817819	Radiator 78-80 99 Tbo	189.95			
8817900	Pump 81-88 900 8 Valves	36.95			
9382649	Radiator 86on 9000 5sp	297.00			
<b>MUFFLERS</b>					
7282007	67-73 95, 96 V4s Front	39.95			
7533631	69-88 All 8V NonT Rear	39.90			
8838005	67-73 95, 96 V4s Rear	31.39			
9326463	81-83 900 Turbos Rear	63.35			
9349143	86on 900 NonT 16V Center	69.50			
9349176	1986 900 Rear	65.95			
9349192	84on 900 Turbos Rear	82.89			
9361817	1979 900 exc CA Front	49.99			
9365511	78-80 99 Turbo Rear	63.98			
<b>POWER STEERING RACKS</b>					
26 980	79&on 900s (Short)	179.95			
26 1980	79&on 900s (Long Rack)	229.95			
<b>REPCO METALMASTER PADS</b>					
111M	76&on 99, 900s (Rear)	21.95			
226M	99, 900 Front Brake Pads	21.95			
<b>KYB GAS-A-JUST SHOCKS</b>					
Lifetime Warranty for most Import and American cars including Saab 21.95 ea					
<b>KONI SHOCKS</b>					
Adjustable Shock (most Saabs) 58.95 ea					
<b>BILSTEIN SHOCKS</b>					
HD Setting for 900 8 valves 66.85 ea					
<b>MISCELLANEOUS ITEMS</b>					
0260257	Wind Deflector 900s	47.50			
8307498	Clutch Disc 99, 900 4sp NT	34.95			
8704116	Clutch Cover 99, 900 NonT	39.95			
8722209	Clutch Slave Cyl 76-85	79.95			
8904575	Brake Disc 69-74 99 F&R	36.95			
8939589	Front Caliper 75-85 All	199.80			
8941981	Frt Brake Rotor 81on 900	36.95			
8944977	Clutch Master Cyl 79-85	66.15			
8948127	Master Cyl 75-85 All	138.25			
8985384	Ball Joints 99, 900	22.95			
9746322	900 Heater Control Valve	80.95			



**900 Service Manual**

PSI 10/90-0030, S-13/P.4

Complete sets of service manuals are pre-assembled. Some recently distributed editions of section booklets may need to be ordered to make the set current.

Complete service manual sets or individual sections may be ordered through your Saab dealer's parts department.

**Complete 6 volume set - 900****03 20 051**

<u>Section</u>	<u>Description</u>	<u>Part Number</u>
0	News M 1991	03 42 600
0	News M 1990	03 39 838
0	Technical Data 79-80	03 36 727
0	Technical Data -88	03 38 509
1	Service 79-83	03 24 210
1:1	PDI/Break-In 89	03 19 624
1:1	PDI/Break-In 90	03 40 216
1:1	PDI/Break-In 91	03 42 782
1:2	Service 85-88	03 38 525
1:2	Service 90-	03 40 224
2	"B" Engine 79-80	03 21 265
2:1	1981-88 Basic Engine	03 38 533
2:3	Fuel System 81-88	03 38 541
2:4	Exhaust, Cooling Systems, Turbo 81-86	03 31 058
3:1	Electrical Systems, Instruments 79-86	03 31 066
3:1	Electrical Systems, Instruments 87	03 35 455
3:2	Electrical System Diagrams 84-86	03 31 074
3:2	Electrical System, Diagrams 87-88	03 38 558
3:2	Electrical System 89	03 19 673
3:4	Wiring Diagrams 87-88	03 38 632
3:4	Wiring Diagrams 89	03 19 681
4	Manual Transmission 79-85	03 26 959
4:1	Manual Gearbox 89-	03 19 772
4:2	Automatic Transmission 79-	03 28 930
5	Brakes 79-	03 31 082
5:2	ABS	03 40 265
6	Front end 79-88	03 38 574
7	Suspension 79-	03 26 967
8	Body	03 25 365
8:2	Interior 79-86-	03 35 505
8:3	Heating, AC 79-86-	03 35 513
8:5	Convertible 86	03 27 981
8:6	Air Bag	03 40 257
9:1	Accessories 79-83	03 14 278
9:1	Accessories 84-88	03 38 608

**Obsolete Individual Sections - 900**

These sections are available while supplies last for customers with older cars for which they are applicable. They do not contain the latest information and should not be used in the dealership context.

<u>Section</u>	<u>Description</u>	<u>Part Number</u>
0	News M 1988	03 36 628
0	News M 1989	03 19 608
1:1	PDI/Break-In 85-86	03 31 017
1:1	PDI/Break-In 87	03 35 414
1:1	PDI/Break-In 88	03 38 517
3:2	Wiring Diagrams 87	03 35 463

**9000 Service Manual**

PSI 10/90-0030, S-13/P.5

**Complete 6 volume set - 9000****03 26 629**

<u>Section</u>	<u>Description</u>	<u>Part Number</u>
0	News M 1991	03 42 691
0	News M 1990	03 39 929
0	Technical Data 86-88	03 37 154
1:1	PDI/Break-In 89	03 13 825
1:1	PDI/Break-In 90	03 41 156
1:1	PDI/Break-In 91	03 42 873
1:2	Service 86-88	03 37 170
1:2	Service 1990	03 41 164
1:4	ISAT (Preliminary)	02 14 254
2:1	Service Manual 86-88-	03 39 408
2:3	LH Fuel Injection System	03 13 858
2:4	Exhaust, Turbo, Cooling Systems 86-87-	03 34 045
2:6	DI/APC	03 41 198
3:1	Electrical Systems 86	03 26 488
3:1	Electrical Systems 87	03 34 052
3:1	Electrical System 88	03 37 188
3:1	Programmable EDU (Preliminary)	02 14 387
3:2	Wiring System Diagrams 86	03 26 496
3:2	Wiring System Diagrams 87	03 34 060
3:2	Wiring System Diagrams 88	03 37 196
3:2	Wiring System Diagrams 89	03 13 874
3:4	Comprehensive Wiring Diagrams 87-88	03 37 295
3:4	Comprehensive Wiring Diagrams 89	03 13 882
4	B234 News Supplement	02 14 601
4:1	Manual Transmission 86-87	03 34 078
4:2	Automatic Transmission Stage 2 86-88-	03 35 596
5	Brakes 86-	03 26 512
5:2	Anti-Lock Braking System 88-	03 37 212
6	Front End 86-	03 26 520
7	Suspension 86-	03 26 538
8	Body 4-door	03 39 580
8:1	Body 88	03 37 238
8:2	Interior 86-87-	03 34 110
8:3	Heating and Ventilation, AC 1985-88	03 37 246
8:3	ACC Version 2 (Preliminary)	02 14 395
8:6	Air Bag	03 13 510
9	Accessories 86-	03 37 261

**Obsolete Individual Sections - 9000**

0	News M 1988	03 36 529
0	News M 1989	03 13 809
1:1	PDI/Break-In 87	03 34 011
1:1	PDI/Break-In 88	03 37 162

**V4 Service Manuals**

Reprints of the following service manuals for V4 models are available and can be ordered from a Saab dealer:

V4 Drivetrain - 95/96/97, 1968-74	02 90 908	\$15.50
Sonett III (97) - 1970-74	01 01 501	\$7.00

Saab Parts & Service Information updates are provided to NINES to assist Saab owners in the maintenance of their cars by Daniel L. David, director, service and technical, and Sten O. Helling, President and COO of Saab Cars USA, Inc.



### Exclusive Offering

Surround yourself and your family with the prestige of SAAB in the warmth of wool. Each garment is individually knitted in sizes to fit all ages, in your choice of colors.

Hats feature a "no-itch" lining at \$14.95.  
Scarves are five feet long at \$16.95.  
Prices include shipping and handling.



Sizes of hats	Colors
Newborn	White with Black design
Toddler (1-4)	Black with White design
Child (5-9)	Navy with White design
Adult	Crimson w/White design

Make check payable to:

**Spectrum Industries**

1083 Waterloo-Geneva Road  
Waterloo, New York 13165

412-238-0900, Parts line  
412-238-0099, Fax line

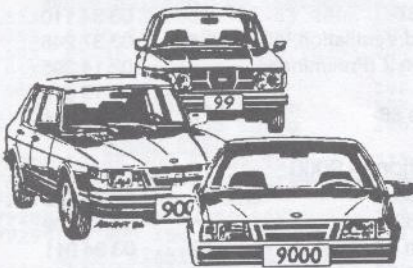

**DENNIS SWEENEY**  
ROAD TESTED SAAB PARTS  
RD 1, Box 410,  
Ligonier, PA 15658

Buying SAAB parts cars and late-model rebuilders every month.

- Computerized inventory -  
Same day shipping on most items.

Used mechanical and electrical parts, interiors, accessories, sheet metal, rebuilt steering racks, wheels, heads, transmissions.

### SAAB NEWS

#### Changes in Saab's future model lineup

The next 900 will be based on an Opel chassis, and a GM-built V6 should be available in the 9000 series as early as 1993 according to an article in the December *CAR* magazine.

Correspondent Georg Kacher claims that Saab's designers have scrapped the former chassis and will instead utilize the Opel Vectra/Vauxhall Cavalier platform. Saab says the new model will only use "some common chassis components." Quoting Saab Automobile AB president David Herman, Kacher writes: "The new car is not a Vectra in disguise. It's very much a Saab, using Saab engines, a typical Saab interior and unique Saab sheet metal."

"The platform is from Opel but the suspension is ours.... [The difference] is at least as obvious as that between the Citroën XM and the Peugeot 605."

The engine for the new 900 will be the current Saab 16-valve four, though whether it will be mounted in-line or transverse has not been revealed. The body, now code-named Project 104, is expected to be offered in three-door, five-door and convertible form. Designed by Saab's Bjorn Envall, look for it in 1993.

Saab's version of the new British-built General Motors V6 should be available as an option in the current 9000 in 1993. It will displace 2.7 liters, with a two-valve edition expected to develop 175 hp and a four-valve version projected at 225 hp. Saab's Direct Ignition, APC, and Saab-designed intake and exhaust manifolds will further "Saab-ize" the V6.

The 9000 replacement, currently called Project 106, is scheduled for the 1995 model year. The hatchback and notchback body styles will continue.

The new top-o-the-line Saab to compete with the Mercedes S-class, Jaguar XJ140 and BMW 7-series, should appear in 1996. In addition to the GM V6, look for it to have rear-wheel drive with all-wheel drive as an option. A V8 engine, possibly GM's new North Star V8 slated for introduction by Cadillac, will also be optional on the big Saab.

#### New tax hits highest priced Saabs

A new "luxury car tax" that goes into effect January 1st could add over \$300 to the price of some new Saabs. The new tax affects all cars priced over \$30,000. Saab has three cars that fall under the new tax -- the 900 Turbo Convertible, the 9000 Turbo, and the 9000 CD Turbo. The surcharge will be 10 percent on the amount of a car transaction that exceeds \$30,000.

The highest priced Saab, the 9000 CD Turbo, has a suggested retail of \$33,995. That translates to a tax of \$339.95.

"It isn't a real problem for us since only a small portion of our line is affected, says Steven Rossi, Saab's PR manager. "We aren't happy with it since the tax is obviously biased toward European cars. There aren't many, if any, American made cars that will be affected by the luxury car tax."

#### U.S. Saab headquarters centralized in one building

Saab Cars USA, Inc. has completed a move that puts all employees at the company's national headquarters under one roof. The modern, 66,000 square foot facility in Orange, Connecticut, is situated next to Saab's former headquarters building.

The older headquarters was built in 1972 and had 44,000 square-feet for office space, with the parts distribution warehouse attached. As Saab-Scania of America grew in the early 1980s, it was evident that larger facilities would be necessary, and planning began for a new "Saab campus" in nearby Meriden. The first of those buildings, a new parts and accessories distribution center, opened in 1986. Eventually, Saab hopes to construct a new national headquarters facility on other land it owns in Meriden.

The new national office is three stories and houses 225 employees. According to Vice President, Finance and Administration, Kenneth F. Adams, "The synergy and creativity of our national and regional staffs will be utilized to their full advantage now that our administrative activities are under one roof."

The old office building and warehouse are for sale.



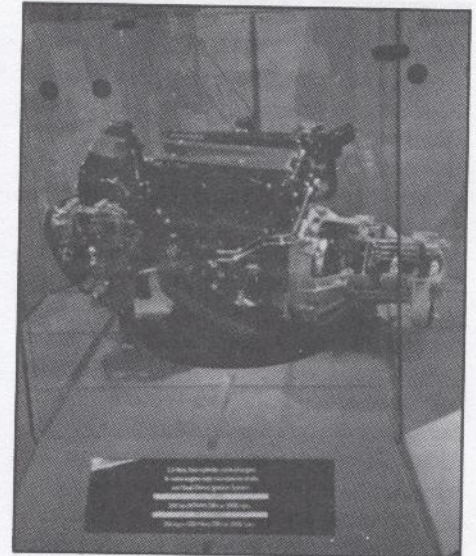

## Don't read this, Mrs. Rossi

"I can't believe it! I'm still high!" said Steve Rossi as we cruised toward lunch at *Zur alten Brauerei* in Fulda, Germany. Steve's adrenalin level had been raised again by a sudden acceleration experience on the autobahn.

We had been traveling in the left lane, waiting for traffic ahead to complete a pass, a Porsche Carrera behind us. When the lane emptied, Steve leaned on the go pedal and began to pull away from the Porsche. It was obvious the Porsche driver was giving it his all as the separation between the two cars grew slowly, but grow it did. Just another case of Teutonic engineering shamed by a Swedish sedan.

There were several such encounters during the two days spent traveling in Germany; encounters with a BMW 750, an Alfa Romeo 164, a Mercedes 190 2.3 Cosworth.

"Don't tell my mother," begged Steve. "She worries that I drive too fast."

Don't read any further, Mrs. Rossi.

As you have read in the October issue of *NINES*, and will probably read in the February and March issues of other publications, the 2.3 liter 9000 Turbo is FAST! To allow magazine writers to experience the new Turbo at its best, Saab took them to the German autobahns, famed for lack of speed limits. Prior to that, our group spent three days in Paris for *Mondial l'Automobile et du Transport*, the Paris Motor Show.

Along for the junket were Paul Lienert, who writes for *Automobile* magazine and

the *Detroit Free Press*; *AutoWeek*'s Wes Raynal; Bob Nagy of *Motor Trend*; *Playboy*'s automotive correspondent, Ken Gross; Mike Allen of *Popular Mechanics*; Fred Abatemarco from *Popular Science*; and John Lamm of *Road & Track*. Bob Sinclair and Steve Rossi were on hand to represent Saab's U.S. distribution arm.

The adventure began when my flight from Minneapolis was delayed on takeoff due to heavy air traffic in Newark, where our group would catch an Air France flight to Paris. There were big doings at the United Nations and all the heads-of-state were landing at Newark, adding to an already full traffic pattern.

The Air France ticketing agent at Newark was cordial as she announced the plane was full. "I'm sorry, but we will have to bump you to Premier Class."

There was more room in Premier Class than in my garage! And none of your typical airline food either. After all, this was not only First Class accommodations, but Air France! I gritted my teeth and accepted the adversity.

Ken Gross took me under his wing for the first day as he had been to Paris before. Our first stop was the *Centre International de l'Automobile* (25, rue d'Estienne d'Orves, Pantin; admission 40F), an auto museum set up like an art museum with several galleries. At the time we were there, the galleries featured the designs of Luigi Colani, a hall of Hispano-Suiza vehicles, a salon of BMW powerplants (motorcycle,

Above left: David Herman holds a news conference at the Saab display.  
Above right: A cutaway of the 2.3 Turbo  
Below: Art in a heap -- at Centre International de l'Automobile



aircraft and automotive), several Gordinis, and a display of famous Renault race and rally cars. The museum also has a restaurant with hundreds of scale model cars in plexiglass cases, and minicars such as a Simca Topolino and an Austin 7 on the floor.

From there it was the nickel (oops, 25 centime) tour of Notre Dame and the Left



Bank, then back to the hotel for some rest before dinner.

Our accommodations were at the *Hotel le Meridien Paris Etoile*. The lounge at the Meridien was called "Jazz Club Lionel Hampton" and the band playing the week we were there was Ellingtonia. Other than MTV on the hotel's cable TV, much of the music heard in Paris, and in Germany for that matter, was American Big Band and older Jazz.

Tuesday morning most of our group took the Metro (subway) to the Parc des Expositions. You can read about the new cars and show cars introduced at the Paris Motor Show in any number of other car magazines, so I'll stick to the Saab exhibit.

It wasn't terribly large and there were only four cars on display, but Saab does not currently sell many cars in France. There were cutaways of the new 2.3 Turbo engine and a short film punctuated with the European advertising slogan, "My Saab and me."

Saab was actually in a corner of the larger General Motors exhibition. Next to Saab were the American-built GM cars and light trucks, across the aisle was Lotus, and just beyond that was Opel, with the Calibra holding center stage.

Several Saab officials were on hand for the show, including Erik Carlsson, Torsten Åman, and Peter Salzer of Saab's PR department; engine development specialist Per Gillbrand; and chief stylist Björn Envall.

David Herman, president and CEO of Saab Automobile AB, held a news conference where he described the first few

months of the Saab/GM joint venture. Herman emphasized that Saab would "continue to operate as an independent car maker, with its own engineering, production and marketing operations," with the advantage that it now has added access to GM's vast resources.

That night (Tuesday, October 2), our group, joined by journalists from Australia and Japan, dined at *Cafe Procope*, "the oldest cafe in Paris," where Voltaire's table is enshrined. At midnight, Mr. Herman toasted the reunification of Germany.

Following dinner, Bob Sinclair decided he wanted to take a late night walking tour of Paris and would anybody like to join him? Sure, why not! Several of our group hiked down the Boulevard Saint Germain ending up in front of the *Deux Magots* cafe, where Bob recognized a couple of automotive business friends and joined them. The rest of us caught a cab back to the hotel.

Driving in Paris is not for the faint hearted, or even the stout hearted, but the

rude and pushy seem to get along fine. Lanes are a mere suggestion, and whoever can get a bumper ahead has right-of-way. Virtually all of the cars I saw had scuffed bumper guards or dimpled fenders. Stick with the Metro or taxis if you're trying to get around in Paris.

Wednesday was another day at the Motor Show, but spent exploring the other facets - the accessory booths and the classic car exhibition. A couple dozen LeMans veterans were the centerpiece of the classic display, but there were also several hundred "collectibles" to be auctioned off later in the week. Among them were plenty of sports cars, a BMW 2002 Turbo, some Alfa Romeo Montreals, a DeTomaso Mangusta, a Lamborghini Countach, plus a Dodge Dart and a Buick Skyhawk, cars you don't see much in Europe.

After dinner at *La Mere Catherine*, a restaurant near Mont Marte, we decided to try the famous Harry's New York Cafe for post-dinner libations. Harry's is one of Ernie Hemingway's old hangouts. It looks much like an American bar, with oak paneling and pennants from American colleges hung around the perimeter.

Somehow we all managed to meet Thursday morning to catch a plane to Luxembourg (the very tired among us slept



Left: Flying past another Trabant  
Below left: Hotel Schloss Wolfsbrunnen  
Below right: Bob Sinclair tries an EMW motorcycle on for size.





on the bus to the airport, in the terminal, and/or on the plane), where we collected our 9000 Turbos for the trip through Germany. Lunch at *La Gastronomie* in Hosert, then off to the autobahn.

By comparison to the freeways in the U.S., the German autobahn is excellent. People are courteous, though with reunification only a few days old, the underpowered East European cars on the road dictated a need for some extra caution.

Those famous little Trabants that we've read about as the freedom transport of East Germans seemed to be everywhere, more common than VWs or Fiats. Several had been abandoned and stripped in rest areas along the autobahns. Those that were motivating along the highway (all of 26hp from 594cc's, top speed - 66mph) were moving chicanes, almost like in a video game, so it was necessary to keep extra alert. The braking power of the 9000 was tested on several occasions when a Trabbie suddenly pulled into the left lane to attempt a pass on a Skoda or Dacia. (For a road test on the Trabant, see the December issue of *Car and Driver*.)

We worked our way across the country to Meinhard-Schwebda, where Saab had booked rooms in the *Hotel Schloss Wolfsbrunnen*, a 20th century castle converted to an inn. Another excellent dinner followed by drinks (pilseners of the Rhine valley, in my case) in the lounge.

Friday began with a trip to Eisenach, in the former East German sector, to see the Wartburg Car Museum. In addition to several famous Wartburgs were several famous EMWs. Yes, that's EMW - Eisenach Motor Werks.

After World War II, the BMW factory in Eisenach found itself in the Eastern zone. They continued to produce several BMW models including motorcycles, but under the EMW banner, and with a red-and-white roundel logo instead of blue-and-white. In the mid-50s the factory switched to production of new designs under the Wartburg name.

We also met Hermann Hanf, who had been a rally driver for Wartburg in the days when Erik Carlsson was driving two-strokers for the SAAB factory. Carlsson and Hanf embraced upon their reunion after nearly thirty years, and reminisced about the good-old-days of rallying.

Bob Sinclair and Paul Lienert stopped at the Wartburg car factory, hoping to get a quick look at the assembly line, but

Chancellor Helmut Kohl was due later in the day to drive a new model off the line, so security was particularly tight.

The 9000s we drove were European spec, and some had Saab's Traction Control System (TCS), an option in the European market. Saab isn't ready to release TCS in the U.S. as it is currently available only with the manual transmission. Saab Cars USA wants to be able to offer TCS on all models, including 9000s with automatic gearboxes (very important in the American market), before making it available here. (Look for a technical description of the Saab Traction Control System in a future issue.)

In European trim, the 9000 does not have an airbag in the steering wheel, but it does have a very comfortable leather-covered version of the three-spoke steering wheel. One of those would sure feel nice on my '85 900 Turbo. Unfortunately, Saab doesn't offer it through the U.S. accessories catalog.

Speaking of the automatic, when you go to take your test drive in the 2.3 Turbo (and you really should give this one a try), drive one with A/T first. (*I never thought I'd ever suggest driving an automatic!*) There is so much torque available that even with a power-robbing automatic (not that the 9000's 4-speed drains a lot of power) there is more get-up-and-go than most drivers will ever need.

Though there are still some who seem to think performance is measured strictly by how fast a car can get from 0-to-60 (any gumhead can drive fast in a straight line), the 9000 integrates a taught suspension with excellent stopping power. Of course, the 9000 remains luxuriously comfortable, and with the improved torque range of the 2.3 turbo, represents continued refinement of a world class European sedan.

Most auto manufacturers have introduced new models since the 9000 first arrived in 1985, but the newest version of Saab's "big car" can and does compete with the best of them, especially when you consider the economical but powerful powerplant. There aren't many V6s that can match the strength and reliability of the Saab 16-valve, four-cylinder.

Just as the Saab two-stroke cars of the '50s and '60s delivered safety and economy in that era, the 2.3 9000 Turbo puts Saab in a good spot heading into the '90s. The tag-line may have been dropped, but it is still "the Most Intelligent Car Ever Built."

*Tim Winker*

## BAD TURBO? REPLACE IT WITH ONE THAT WILL LAST

### WATER COOLED TURBO CONVERSIONS

FROM  
**\$499**

We use the same Garrett Airesearch water cooled bearing housing that Saab uses on the new models and combine it with aircraft quality plumbing to offer you an elegant and highly functional replacement alternative to the outdated air cooled turbocharger.

# SWEDEKIT®

SWEDISH REFINEMENTS, INC.

191 WESTON ROAD, BOX 622

LINCOLN, MA 01773

**800-726-7740**

Dealer inquiries welcomed

## Specialty Car Care Products

### zymöl

We are a new company, but a long time SAAB enthusiast. ZYMÖL is a non-abrasive car care system, using all natural ingredients.

Here is a partial list of ZYMÖL products:

Cream Wax	8oz.	\$25.95
Carbon Wax (for dark colors)	8oz.	\$27.95
Detail Wax (for hard plastic)	2oz.	\$4.95
Saab Wax (endorsed by Bob Sinclair)	8oz.	\$27.95
Cleanse	4oz.	\$5.95
Brite (wheel cleaner)	4oz.	\$5.95
Treat (leather conditioner and treatment)	8oz.	\$10.95
Vinyl	4oz.	\$5.95
	8oz.	\$10.95

ZYMÖL Starter Kit - includes wax (specify), 8oz. HD-Cleanse, 8oz. Clear, Car Care booklet, towel, applicator, window decal, jacket patch. \$54.95

Complete ZYMÖL Kit - an assortment of products plus detail brushes, schpritzer & carry case \$129.95

Postage and taxes included in prices.

We accept Visa & MasterCard

**1-800-245-2546** USA & Canada

24-hour answering machine

We will call back

## Specialty Car Care Products

786 Baylor Road  
Rochester Hills, MI 48309



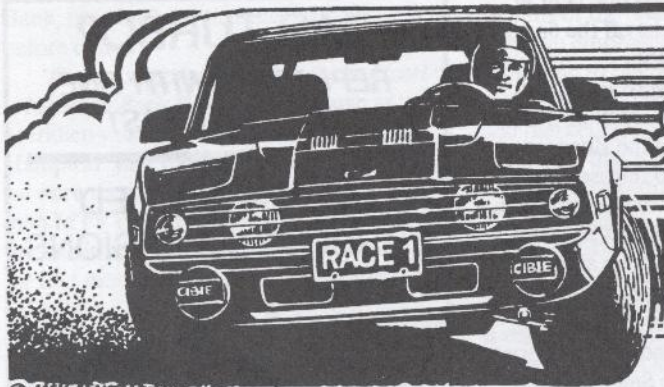

# SHIFTIN' GEARS

by Jack Ashcraft

© JACK ASHCRAFT '90



A few years ago I illustrated a little book called, "Mike Greer's Guide to Greater Gas Mileage". It poked fun at a great many highly touted mileage "improvers" that either did nothing at all or actually wasted gas. Fear-Freddy, shown here, was the reader's guide through the book. As gas prices climb dramatically due to the Mid-east crisis and attendant oil company price gouging, many purveyors of these useless gadgets have dusted them off and are once again happily bilking the public with their great "inventions" that the oil companies have tried to keep off the market". I hope you are not one of those bilked.

## FEARLESS FREDDY'S FANTASTIC FUEL SAVING FRUMPMOBILE FOUR!

A FRIEND OF MINE IS A GAS SAVER GADGET FREAK. HE'S TRIED EVERY DEVICE EVER OFFERED TO CUT CONSUMPTION, MOST OF WHICH DIDN'T WORK. SOME TOOK MORE GAS AND A COUPLE WERE PLAIN DISASTER FOR FREDDY'S ENGINE! THE WATCHWORD FOR YOU SHOULD BE CLEAR, EVEN WRITTEN IN LATIN: CAVEAT EMPTOR - "LET THE BUYER BEWARE!"

- OTHER MILEAGE MAKERS, OUT OF SIGHT IN THE CAR:
- FIVE SPEED GEARBOX.
  - TWO SPEED REAR END.
  - SPACE SAVER SPARE.
  - MAGNESIUM WHEELS.
  - VENTED DISC BRAKES.
  - FIBERGLASS FENDERS.
  - FIBERGLASS BUMPERS.
  - AIR HYDRAULIC SUSPENSION.

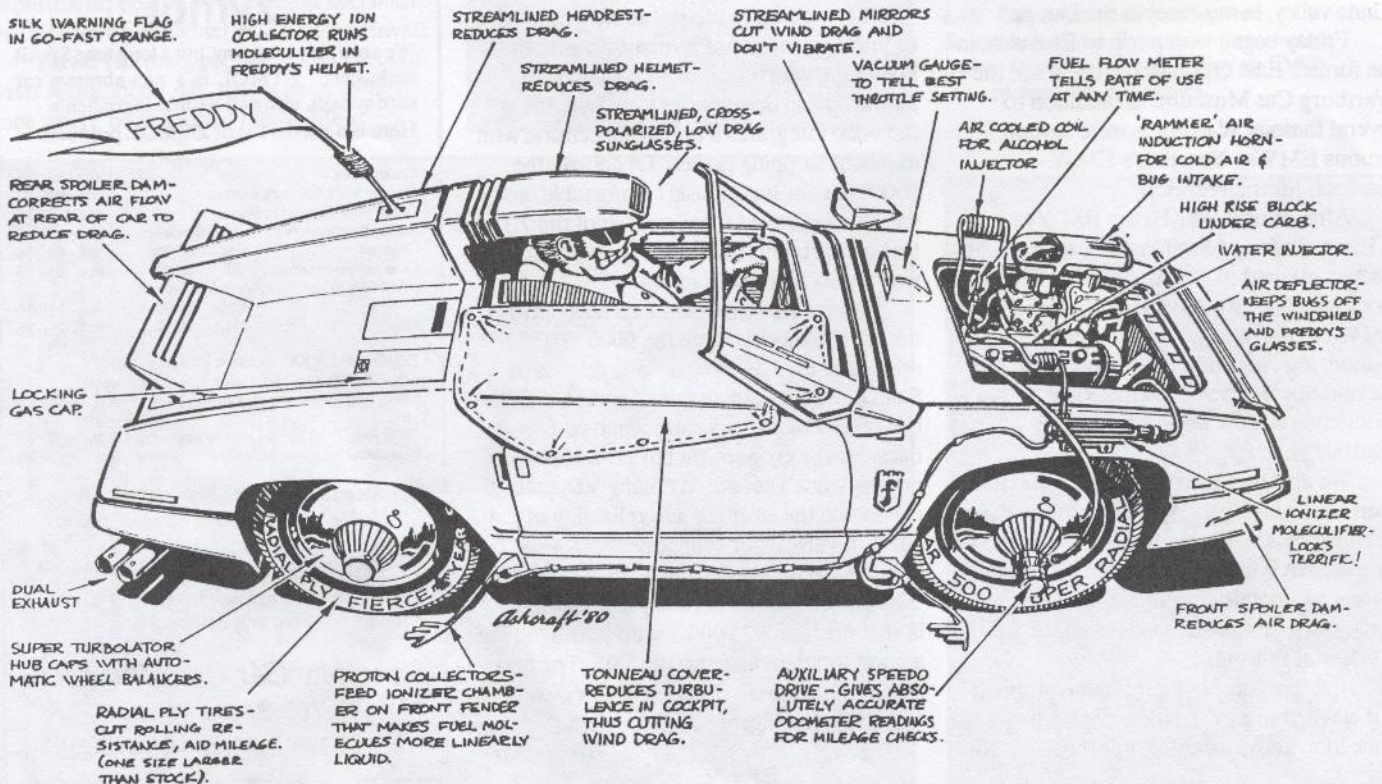



## SOME FUEL SAVING TIPS THAT WORK:

While most gadgets **don't** save gas, there are some things you do to make your car a bit more miserly, including:

- 1--Keep it tuned up. New plugs, plug wires, and points if your car has 'em, will help a lot to get at least the mileage the car was designed to give.
- 2--Change the air filter. One partly plugged chokes the engine and even the fuel injection computer can't compensate for it after awhile. **Check it!**
- 3--Keep the front **and** rear ends aligned. Energy is wasted if wheels don't point where they were designed to point!
- 4--Keep the tires pumped up! Some smart professor recently estimated that a million gallons of gas are wasted **daily** in this country due to underinflated tires. **Checked yours lately?**
- 5--Leave your junk at home. I have a friend who has a couple hundred pounds of junk in his trunk all the time and bitches because his fat aunt Mildred screws up his gas mileage when she rides to church with him. **Clean out the trunk!**
- 6--Take off the ski rack! A lot of yuppies want everyone to know they own skis even if it costs them 3-5 mpg to prove it! **Take it off!**
- 7--Extended morning warm-ups. Makes the car comfortable but gas mileage is zero. Give it 3 or 4 minutes unless the temp is sub-zero, then drive off. Wear a sweater and don't lug or rev the engine up very much until the gauge says "N". If you are faced with **COLD** weather, have a block heater installed and plug the sucker in at night!
- 8--Watch your driving habits. Ease away from lights. Flow with the traffic. Watch 'way ahead of yourself. Try to hit the lights without stopping. It all helps to save gas. Be smooth.

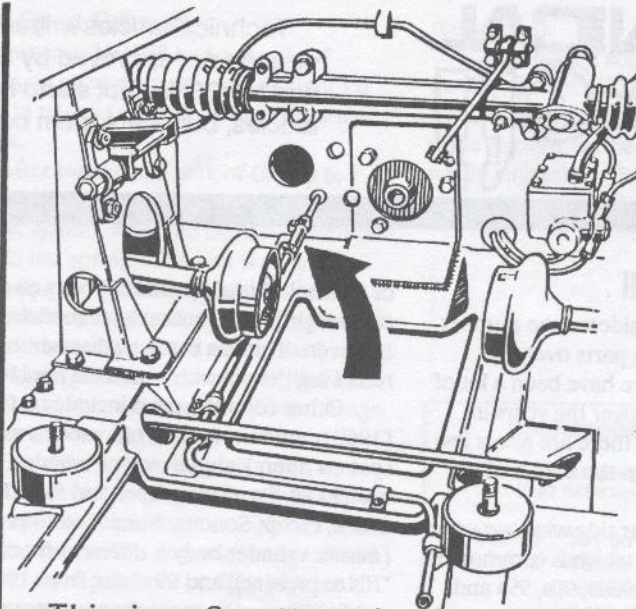

## SONETT FUEL HOSE FIX

This is a Sonett engine bay with the engine and transaxle **out**. The arrow points to a fuel hose that deteriorates with time and is sometimes the source of a hard-to-locate fuel leak. The rule of thumb here is if you can see it, **change it!** Once the transaxle is back in, it is **extremely difficult** even to see, let alone to **change!**

## SONETT III HOOD PIN REPLACEMENT

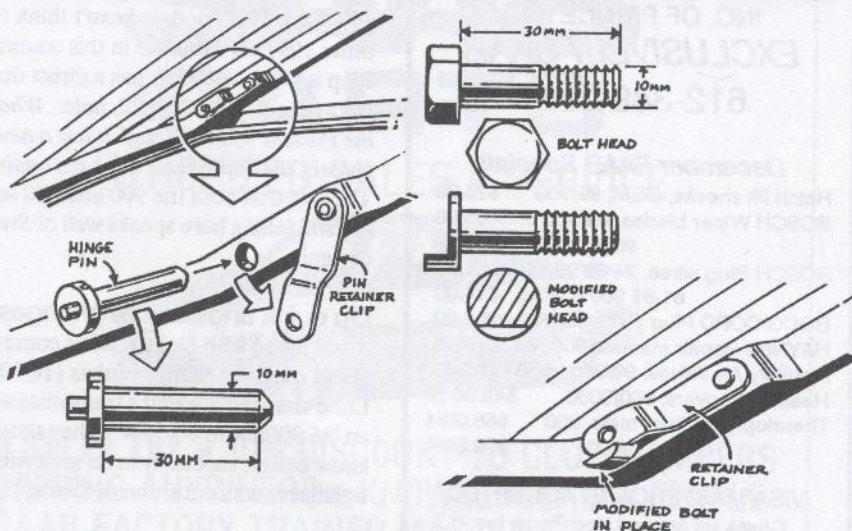

Lost Sonett III hood hinge pins can easily be made up by grinding down the head of a 10mm bolt as shown. The retainer clip mounted on the hood now holds the modified bolt in place just as securely as the original pin. You may wish to paint the bolt head to prevent rust, and to coat the rest of the bolt with light grease, which will prevent rust and make the hood open smoothly.



# TECHNICAL TALK



Technical articles written by subscribers may recommend procedures or parts not approved by Saab-Scania of America, Inc. The SAAB Club and NINES cannot stand behind the correctness of information in these articles, but offers them based solely on the experiences of the writers.

## One part fits all

Have you ever considered the number of interchangeable Saab parts over the years? Yes, I know there have been a lot of changes/improvements over the years in parts for these cars, but there are also a few holdouts from the '60s in the design of the 1991 900!

The three-door rear side windows open with a latch mechanism which is common to all two- and three-door 900s, 90s, 99s and 96s dating back to at least 1963. My neighbor recently needed a new latch for his '83 900 Turbo, and in checking my multi-colored collection of 96 windows I found the '63 was the same as the '83 except that the later one had better chrome. The Saab part number - #716656 - was consistent for 20 years of models! The last link (#8401150)

of the multi-hinged latch that bolts on the car is slightly different on later models, however. This can easily be disassembled by removing the pin with a suitable punch.

Other common parts include oil filters (1967 to present four-stroke models with spin-on filters), clutch master cylinder rebuild kit fits all two, three and four digit Saabs, except Sonetts, from 1969 to present (master cylinder body is different from mid-'70s to present), and 99 doors from 1969 will fit 900 models more than twenty years later.

Thanks to Saab mechanic/whiz Eric Nelson for the following item: Upper control arm bushings are the same from the 93 through the 900 series. What foresight those Saab engineers had in the early '50s when they designed the 93!

It is interesting to note that of new cars, only the Saab 900 series and the Volvo 240 series have direct linkages to cars designed in the 1960s. The 99 was introduced in 1969 after years of testing. The first Volvo 140 was a 1967 model. I can't think of any other 1991 car available in this country (the Jeep is not a car!) that has a direct design linkage to the 1960s. [Ed. note: *What about the Porsche 911? Though it has a new chassis, the body shape has been retained.*] The fact that both the 900 and 240 series are still selling here speaks well of Swedish design!

### On quick and thick oil changes...

I agree with Doktor Nio's comments about quick oil change outlets (10/90). Jiffy Lube changed a friend's transmission oil on an '86 900S with 80-90W. They should know better, especially in an area with a significant concentration of Saabs.

### On the Real Long Run...

Shep Siegal, who wrote about his long term dedication to driving the '82 900, was concerned about salt damage around the wheel wells. Removal of the trim pieces around the opening may slow or reduce corrosion in the future. If they must be left

on, I recommend removing the trim, cleaning the trim and the fender arch, and remounting with a coating of clear silicone caulking. Once the trim is on, carefully wipe off excess caulking, but leave a barely perceptible trace at the trim edge all the way around. Make sure no salt water can get under the trim or rest at the trim edge, and the salt will look elsewhere to cause problems - tops of mudflaps, inside jackports, etc.

My 1971 95-V4 has been in my ownership for almost twelve years and now has over 233,000 miles; going strong on a rebuilt engine and transmission. Camshaft and rear wheel bearings, and most balljoints are still original. The Original balance shaft bearings lasted just over 200,000 miles! I attribute long life on the water pump, fan shaft bearings and alternator bearings (mine have lasted over 110,000 miles) to not over-tightening the fan belt. See the Saab recommendation in the manual of 7mm belt play.

### On clean connections...

Our '79 99GL refused to start one recent day. Given prior experience with fuel pump relays and fuel pump replacement, I noticed the pump wasn't sounding as I turned the key and the starter cranked the engine. Checked fuel pump and relay contacts - fine. With the relay removed, I jumped across the 12 o'clock and 6 o'clock located relay terminals (this can be done with a paper clip in an emergency) and still no pump action.

I studied the wiring diagram and found the current must flow through one contact of the ignition relay (a shorter relay located adjacent to the fuel pump relay). I removed the ignition relay and found corrosion, cleaned the prongs, and the pump did its thing once again. In the past I have found the fuel pump relay contacts to cause the same problem.

Roger S. Harris  
Springfield, MA

# andrews

INC. OF PRINCETON  
EXCLUSIVELY SAAB

612-389-3805

### December SAAB Specials

Hatch lift shocks, OEM, 99/900	\$25.00
BOSCH Wiper blades, 99/900	\$5.00
9000	\$6.50
BOSCH Plug wires, 74-80 99/900	\$11.00
81-87 900 8 valve	\$14.00
BOUGICORD Plug wires, all 16v.	\$55.00
HAYNES Repair manual, 900 -88	\$19.95
Auxiliary Air Valves, 99/900	\$50 - \$60.00
Headlight covers, 900/9000	\$45.00/pr
Thermoplastic floor mats, 900	\$68.00/4
9000	\$90.00/4

VISA/MASTERCARD ACCEPTED

Check us out on Used Parts, too.  
All prices plus shipping

TOLL FREE PARTS LINE

1-800-882-7220

(Fax#: 612-389-3875)

Route 4, Box 247

Princeton, MN 55371



## 900 wiper repair

Doktor Nio's claim in the October NINES that the driver's side windshield wiper mechanism can not be repaired in the car is false; I did it twice last winter on my wife's '85 900T.

If one removes the driver side wiper arm and then removes the rubber boot at the base, just enough of the cable/cam mechanism is accessible to re-install the cam on the spline and wrap the cable about the cam. A very small (jeweler's size) screwdriver is needed, as well as a pair of needlenose pliers (or a small open box wrench - 5mm?). The pliers and screwdriver are needed to loosen the lock nut at the end of the cable so there is enough slack to wrap it about the cam and then tighten it.

**WARNING:** You need a lot of patience to do this due to the limited access, but it is not impossible.

Why did I end up repairing the wipers twice, you ask? Well, I lost my patience and failed to tighten the cable sufficiently, and the blasted thing slipped off again two days later (yes, we get lots of rain). So far, it has held.

## 9000 Sport Exhaust

Previous NINES had a couple of articles on sport exhausts, so I thought I'd throw in my two cents now that I have a chance.

After talking to Frank of Group 6, I decided to go with his non-stainless Sport exhaust system, which he had advertised in NINES last spring. The unit is a chromed dual-tailpipe ANSA unit, with the usual horsepower and gas mileage improvement claims. I honestly can not claim that I can detect the eight extra horsepower, but I don't live at the redline either. Gas mileage appears to be about three percent better, which means that the thing will pay for itself in about 3.2 years at the current gas prices and at my annual mileage.

The system was very easy to install and the fit to the stock from muffler pipe and rear hangers was excellent. The only problem was in clearing the rear valence. Since the hole for the stock tailpipe is narrower than the sport exhaust, the corners of the valence will rest on the new tailpipe, so it's necessary to trim the hole. Once properly installed, the chrome tips look

really sharp.

How does it sound? Sounds fast and throaty. However, at low rpm (1500-1800) there is a deep rumble that can be annoying while bucking traffic in 1st and 2nd, so I would suggest city folk to save your stock rear muffler for awhile.

Tony Gounalis  
Endicott, NY

### hakkapeliitta snow tires

THANK YOU FOR YOUR  
PAST PATRONAGE AND SUPPORT

185/65-15	\$61.00	165SR-15	\$56.00
185/70-13	\$51.00	185/70-14	\$60.00
18 other sizes available CALL FOR PRICES			

185/65-15 & 165-15 Nokia Rollsters

G & G Service

4073 Hubertus Rd

Hubertus, WI 53033

414-628-1716

## J & B Imports

Saab & Volvo  
Service & Repair

(714) 282-7378

Factory-trained technicians  
with over 45 years  
combined experience

Specializing in:

- All years
- All models
- Turbo repairs
- Turbo performance
- Two-stroke engine repair

We've moved recently  
Visit our new location

2296-A North Batavia  
Orange, California 92665

# SAAB PARTS

AUTHORIZED SALES • SERVICE

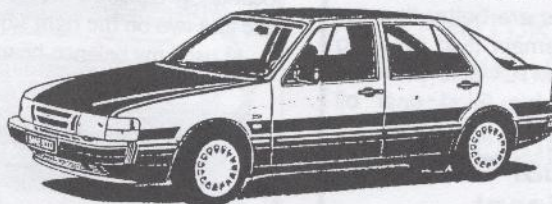

NO SALES TAX • 10% DISCOUNT TO CLUB MEMBERS  
SHIPPING ANYWHERE • KNOWLEDGEABLE PEOPLE  
SAAB FACTORY TRAINED MASTER TECHNICIANS

ALL MAJOR CREDIT CARDS ACCEPTED

**Monte Shelton**

MOTOR COMPANY

1638 WEST BURNSIDE • PORTLAND, OR • 503/224-3232

ROLLS ROYCE • JAGUAR • SAAB





## TOUGH SHIFT?

In order for a transmission to shift properly, the oil must be squeezed from between the synchros and the slipperiness of the oil must be overcome so that the synchros can come to equal speeds. Oils which are too thick or too slippery will cause shifting difficulty. Modern motor oils contain additives to enhance slipperiness and improve fuel economy, which slows synchronization. In order to speed cold shiftability, SAAB recommends low viscosity lubricants such as 10W30 or 10W40 motor oils or 75W gear oils. These lubricants are generally too slippery and the shearing forces of the gear teeth reduce the viscosity of these lubricants to the viscosity of an ATF within a few thousand miles. This reduction in viscosity causes gear whine and accelerates gear wear.

Red Line MTL<sup>®</sup> significantly improves many of the shiftability and noise problems found in SAAB transmissions. It is an 80W (almost 85W) GL-4 gear oil which provides the same high temperature viscosity as a 10W30, but it will not lose half its viscosity like a 10W30 motor oil. The low temperature characteristics are better than an ATF and it will remain fluid down to -50°F. Red Line MTL<sup>®</sup> also provides gear protection of a GL-4 gear oil which is far superior to a motor oil.

### MTL<sup>®</sup> - Manual Transaxle Lubricant

- Perfect synchro friction coefficient
- Eliminates notchy shifting
- Excellent shifting even when cold
- High-performance gear protection
- Eliminates gear whine
- Non-corrosive to synchronizers

Red Line Synthetic Oil Corporation  
3450 Pacheco Blvd, Martinez, CA 94553  
(800) 624-7958  
Call or write for technical literature

## Low cost B-engine pistons

Two-liter Ford Pinto pistons can be made to replace standard Saab 2.0-liter pistons (B-engine, 1973 thru '80) at less cost. I did this in my '76 99 and have so far been satisfied with the results. Standard 2-liter Pinto pistons are about 30-thousandths larger than the standard Saab units. My machine shop did the bore job to the Pinto specs without any problem.

Some modification was required to complete the substitution, however. The Pinto piston wrist pins are a press fit onto the connecting rod small end, whereas Saab pistons are retained by circlips. I had eight small "buttons" made that fit the ends of the wrist pins to keep the pins centrally located. These "buttons" were made from Teflon rod that was machined to insert into the pin ends and then radiused flush to the piston outer diameter.

The second modification required removing a portion of the piston skirt that interfered with the rotation of the crankshaft on the downstroke. I solved this problem by grinding away a section of the skirt that was in the way of the counterweight. It was easy enough to see what needed to be removed by inserting the piston into the cylinder and loosely bolting the rod to the crank, turning the crank, and marking the portion that was in the way. To do the grind, all I used was an electric drill with a small grinding stone that I got at Sears. I carefully removed the metal down to where there was no longer any interference with crank rotation. Less than 50-percent of the circumference of the skirt was involved. Owing to counterweight location, two pistons are ground on the left side and two on the right side.

I used my balance-beam kitchen scale

to balance the pistons assemblies. I found the lightest of the four pistons then balanced the remaining three to that weight. To do this I turned the piston upside down and with a 3/8" drill bit removed metal from the bottom of the piston crown. I made shallow dimples (kinda like on a golf ball) until I had removed enough metal to balance each piston assembly (piston, conrod, pin & buttons) to approximately (within a few grams) the weight of the lightest assembly.

The pistons cost me \$16 (I got a deal), rings cost \$32 per set, the buttons were \$9 each. My total outlay not counting labor, was \$120. This is less than I was quoted for just one Saab piston with rings and pin.

After ten months on the road as my regular going-to-work car, I have not had any problems with this set up. I believe this would also work with V4 and 900 engines, but I have yet to attempt it.

John Ogilvy  
Durham NC

*[Andy Buc outlined how to use Capri 2600cc V6 and Pinto 2000cc pistons in the Aug./Sept. 1988 issue. - TW]*

**NICHOLAS PELLEGRINO**  
FOREIGN MOTOR REPAIR

SALES **SAAB** SERVICE

282 ENFIELD MAIN RD. ITHACA, NY 14850  
607/272-8259

PORSCHE SAAB AUDI BMW	<b>AUTO SPORTS</b> UNLIMITED	MERCEDES-BENZ VOLVO VOLKSWAGEN JAGUAR
--------------------------------	---------------------------------	--

**EUROPEAN AUTO PARTS**

**616-457-6790      1-800-624-EURO**

SAME DAY SHIPPING

0774 CHICAGO DR - JENISON, MICHIGAN 49428



## Throttle body "cooling"

I have experimented with disconnecting the coolant hoses and bypassing the water jacket in the throttle body in my 16-valve 900 Turbo. The hot coolant flowing through the jacket heats up the throttle body and subsequently the intake air that has been cooled in the intercooler.

My reasoning is this: Bypassing the jacket would lower the temperature of the intake air to the cylinders and thus improve engine performance. It appeared to me that the temperature of the incoming air would rise the most at small throttle openings (i.e. city and moderate speed highway driving).

This theory does work in practice. The throttle "tip in" is improved and the engine will pull from lower revs than before. Second gear starts are not a problem; use second gear as you would first. To date I have not had any problems with the throttle shaft/blade freezing. The engine cylinder head heat transferred to the intake manifold prevents that.

The engine is positively torquey at low speeds. The fuel economy is unaffected. In addition, the boost builds up quicker to higher levels, especially after some slow city driving. Lacking sophisticated thermocouple instrumentation, I popped the hood and touched the intake manifold to check the experiment. It was positively cool to the

touch. I have no idea how emissions are affected by this modification.

Jacek Filitkowski  
Gig Harbor WA



# SAAB

93 95 96 97:  
RESTORATION & REPAIR  
USED PARTS \* TECH INFO  
BODY WORK \* PAINTING \*  
MOTOR & TRANS. WORK \*  
RUST REPAIR & WELDING

**Nordic Motors** everything for the 90's!

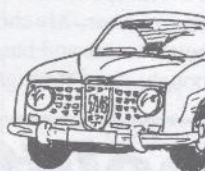

(617) 861-7451

## CAMPBELL/NELSON Auto Wrecking

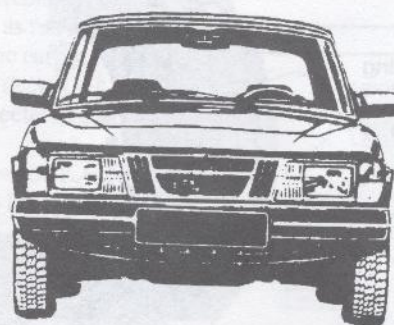

# SAAB

### USED PARTS CENTER

205th & Aurora, P.O. Box 220  
Edmonds, WA 98020  
1-206-771-4931  
1-800-552-2999  
(Out of State)

## OVERSEAS AUTO PARTS

KYB GAS SHOCK \$23.40

99/900 MUFFLERS WITH  
CONNECTOR PIPE \$52.82

MANN OIL FILTERS \$6.26

BALL JOINTS \$25.95

REPCO METAL MASTER  
BRAKE PADS-  
FROM \$19.94

NGK SPARK PLUGS \$1.65

HALOGEN BULBS-H9004  
\$9.95

AIR FILTERS \$5.95  
99 & 900 NON TURBO

REBUILT STARTERS,  
ALTERNATORS, CALIPERS,  
BOSCH IGN. & F.I. PARTS  
AND LOTS MORE!!!!  
AT DISCOUNT PRICES

M/C AND VISA WELCOME  
WE SHIP ANYWHERE

OFF BRIDGE STREET  
BRATTLEBORO, VT 05301

U.S. (800)544-4600

## BOB YATES IMPORT CAR SPECIALISTS

### Clearance Sale!

- Gislaved Snows w/steel wheels \$125. ea
- 15x5½ 15-spoke take off wheels,  
'88 on 900/9000 \$125. ea
- 15x6 Cartech Gold 5-spoke alloys,  
all 9000 & '88-on 900 \$750./set
- Nevada Brown armrest, 9000 \$150.00
- Rocker panel trim kits, 9000CD \$99.00
- Bilstein R2000 Paint Sealant or  
Fabric Protector 2 for \$8.00
- Fold down armrest, 900 \$99.00

Call for more specials!

TOLL-FREE PARTS LINE  
1-800-669-SAAB

Fax# 215/752-5614

Discount to SAAB Club members

Rt. 1 & I-95  
Langhorne, PA 19047



## Replacing the OE 900 speakers

Thinking of upgrading the speakers in your 900? There is very little room for a standard size speaker, so Saab installs long, narrow speakers, 4" by 10", in the parcel shelf supports just under the C-pillar. You can easily see them from the trunk area. Some earlier 900s were delivered with a 4" speaker with a square mounting pattern.

The rear speakers in my used '85 900 Turbo were 50 watt triaxials (P/N 85-99-441 according to the label on them). I don't know if they are Original Equipment or Saab replacement speakers. To my ears they sounded "muddy", pretty good bass, but not much treble.

I thought it would be a simple job to remove the old speakers and install the new ones, just remove the four screws that held each speaker to the body. Wrong! The speakers are attached with bolts and nuts, and the nuts aren't welded into place. That means it is necessary to remove some of the interior trim.

Start by peeling the weatherstrip rubber that surrounds the hatch, beginning

at the rear of the parcel shelf support. This exposes the piece that covers the interior of the C-pillar, the one covered with headliner material.

There are two plastic "rivets" holding the speaker grille to the shelf supports. Carefully pop those off with a flat head screwdriver, remembering that you'll have to re-use them. Slide the speaker grille piece carefully out. You may have to lift a little to get over the ends of the speaker bolts, and you may have to remove the plastic cover over the parcel shelf stop. Rotate the grille piece forward a quarter turn, twisting the rear seat belt where it comes through the grille piece.

The bolts and nuts are both 7mm. Use a socket from underneath and a wrench on the top side to remove them.

The choice of speakers is somewhat limited, though the Crutchfield catalog (800-336-5566) lists a half dozen possibilities. I ended up with a pair of Pioneer TS-4133s, a coaxial rated at 120 watts maximum power. My choice was based on better treble and bass sound. By the way, I bought them through a local retailer and

not mail order. This gave me the chance to hear them compared to several others. (Note: I also tried Pyle K-P4116Ds, but thought they sounded "soft".)

The rubber spacer on the Pioneers was thinner than on the Saab speakers, so I put the bolts in from the top with washers and nuts on the bottom. Otherwise the bolt ends would have torn the speaker grilles.

The front speakers are "hidden" in the dash next to the defrosters. The speaker size is 4" Square (not to be confused with 4" which implies a circular mounting surface).

The plates that hold the speakers may have either Philips or Torx T-10 screws. Check both sides before you proceed (believe it or not, they could be different). Lift on the back, the edge closest to you (you may need to use a flathead screwdriver as a prybar), and slide the plate back toward you and out.

The speakers are held into place with metal clips. Carefully remove these with a flathead screwdriver, lift the old speaker from its plastic pegs, and replace it with a new speaker.

Though I tried a couple of different speakers in the dash, (Pioneer TS-1001 and Sony XS-1021) neither sounded better than the OE Saab speakers (made by Luxor in Sweden), so the old pair was returned to their homes.

My suggestions here have been limited to replacing the stock speakers in their stock locations. According to the folks at Saab, several different 4x10s were tried in an effort to clean up the sound, but the problem has more to do with the limited area where speakers can be mounted. Speaker location has more to do with good audio sound than most other variables, so you may consider mounting more speakers in the rear parcel shelf, back seat side (or door) panels or front door panels.

There are, of course, other ways to get better quality audio in your Saab, such as adding an amplifier (or two), or an equalizer/booster, or upgrading the radio itself. Speaker replacement in my car was in preparation to replacing the receiver/cassette player sometime next year.

Write and let other Saab owners know what you've tried -- what works and what doesn't.

Tim Winker  
Duluth, MN



## Hakkapeliitta® 10

The world's best snow tire just got better!

### Hakka 10

- Three or four longitudinal grooves give stability in slush and snow.
- Low frequency zigzag of grooves gives driving comfort and stability in traffic grooves.
- Carefully designed, open sipes balance the grip in all directions cornering and driving.
- Special design of the pattern maintains excellent side grip.
- Special block pattern with Hakkapeliitta appearance.
- Directional pattern gives excellent behavior in slush and snow.



Also available mounted and balanced on Saab 900 and Saab 9000 original equipment steel wheels.

Tire studding available. Lowest prices.

SAFETY, PERFORMANCE and QUALITY from FINLAND

Now in stock for VINTAGE SAABS:  
Nokia Lapponia 155SR-15  
summer tires

For more information and to order: GREER ENTERPRISES



1810 E. Jarvis  
Milwaukee, WI 53211  
(414) 964-7463



## Kenwood sound system

Recently I decided to upgrade my 1986 SAAB 900's stereo system. The first change consisted of adding two new head units -- a Kenwood KRC-858 cassette receiver and a Kenwood KDC-80 Compact Disc player. Both of these units are mounted in the center console. I chose this location to prevent easy visibility from people walking by. To achieve this I removed the pocket and slightly notched out the sides to allow for the second chassis to fit. Below that I mounted a Kenwood KGC-4400 equalizer to fine tune the variety of music I listen to.



The biggest problem I was faced with was coming up with a speaker arrangement that would not involve cutting holes in the interior to maintain a factory appearance. The speakers I chose for the dash were the Kenwood P104 kit. It contains a pair of four-inch midrange in the factory spot in the dash, plus a pair of one-inch tweeters. I placed a second pair of defrost vents behind the factory defrost vents and mounted the tweeters under them using a hot glue gun. This allows for excellent front imaging and fill.

For the rear deck I chose a pair of Kenwood W210 subwoofers and a pair of Kenwood W108s to use as midrange. Here I was faced with another problem, coming up with a way to mount the speakers on my already sagging rear deck. Seeing no other alternative, I built a new rear deck from 5/8" particle board. The new deck is a two-piece unit due to the enormous speaker weight.

The original deck was outlined on the sheet of particle board, then I cut it out. I placed the speakers on the deck to get the general layout. Then, allowing enough room, I cut the speakers to be placed under, and hinged the two pieces together.

I carpeted the deck over the hinges and speaker holes to prevent them from being seen. The carpet was purchased from an auto carpet specialty company, which referred to it as "stretch carpet." Spray adhesive holds it in place. The same carpet was used to recover the the side panels on either side of the deck.

I placed a pair of Kenwood T101 one-inch tweeters on the side panels that hold the deck.

The power plants for this system are two Kenwood KAC-8070s with a 210-watt maximum output, and a Kenwood KAC-9020 that

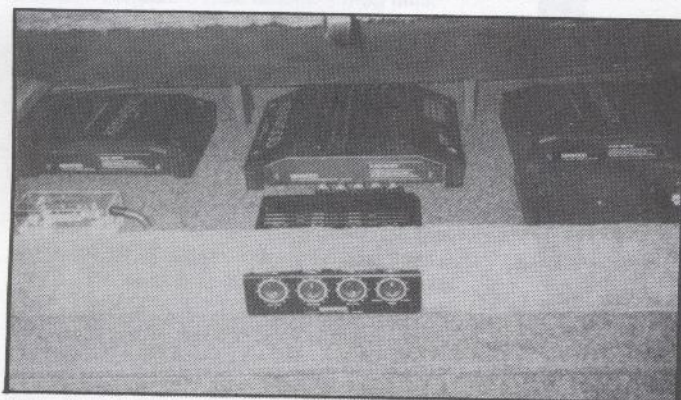

Amps are hidden under a false floor in the trunk.

has a 320-watt maximum output. These are all controlled by a Kenwood KEC-300 active crossover. With this system I have a sound pressure level of 136, with a maximum power output of 740 watts.

The possibilities for sound systems in Saabs are really only limited by the individual. For instance, in the March/April 1989 issue of Car Stereo Review there is a 1988 SAAB 900 Convertible with a 960-watt system that ballparks for around \$13,000. Mine on the other hand, including a phone and alarm, cost less than \$3,000 and is very equal in sound quality and component quality. Don't think that a quality system is out of reach, because it isn't.

Todd Campisano  
Louisville, KY

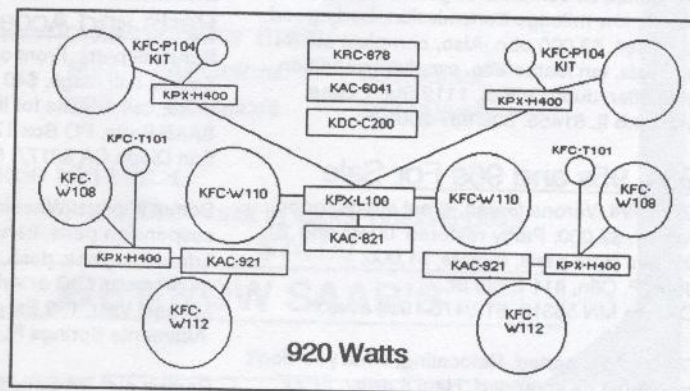
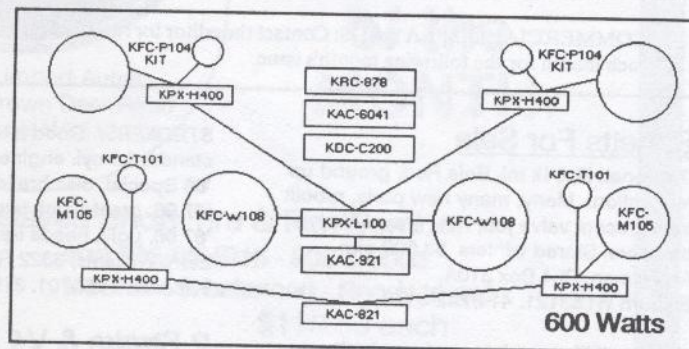
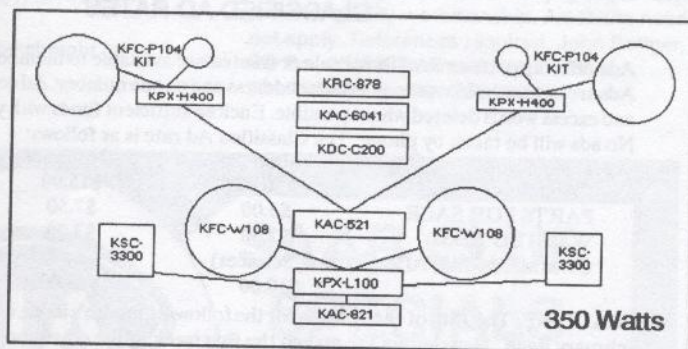

### Three possible systems using Kenwood components

KRC-878	Cassette-Tuner with CD control	KFC-P104	1" Tweeter & 4" Midrange Kit
KDC-C200	Multiple CD Player (optional)	KFC-T101	1" Tweeter
KAC-6041	Parametric Graphic Equalizer	KFC-M105	5" Midrange
KAC-521	Stereo Power Amplifier	KFC-W108	8" Subwoofer
KAC-821	Stereo Power Amplifier	KFC-W110	10" Subwoofer
KAC-921	Stereo Power Amplifier	KFC-W112	12" Subwoofer
KPX-L100	Low Freq. Passive Crossover	KSC-3300	Plate-type Speaker System
KPX-H400	High Freq. Passive Crossover		



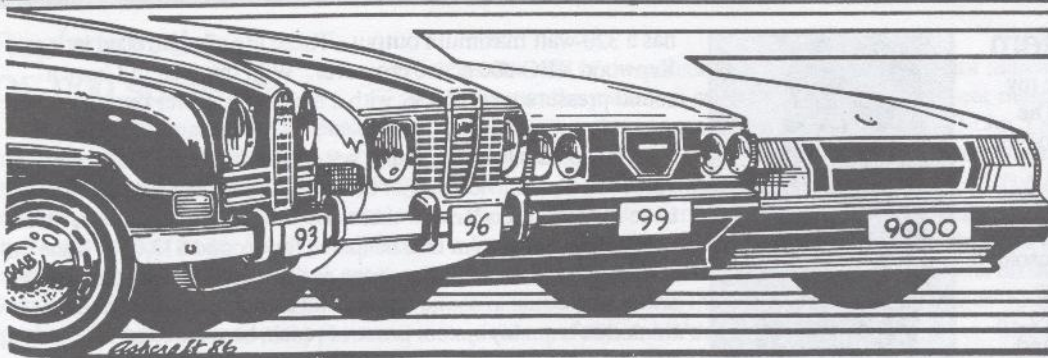

# SAAB SWAP

CLASSIFIED ADS

## CLASSIFIED AD RATES

Ads offering parts or SAABs for sale or wanted are available to members and non-members. Ads are limited to 25 words, plus name address and phone number. Ad copy will be abbreviated and excess words deleted where possible. Enclose sufficient funds with your ad, we do not bill. No ads will be taken by phone. The Classified Ad rate is as follows:

	Members	Non-members
CARS FOR SALE	\$10.00	\$15.00
PARTS FOR SALE	\$5.00	\$7.50
WANTED ADS.	\$2.00	\$3.00
COMMERCIAL ADS (Parts & Services)	\$10.00	\$15.00

DEADLINE: The 15th of each month for the following month's issue, e.g. January 15th for the February issue. Newsletters are mailed the first week of the cover month.

COMMERCIAL DISPLAY ADS: Contact the editor for rates and info. Deadline, the 10th of each month for the following month's issue.

## Sonetts For Sale

'73 Sonett III, 84k mi, Baja Red, ground up restoration. Many, many new parts, rebuilt trans, recent valve job, new tires, old-style bumpers. Stored winters. \$3,500 obo. Art Tillman, Rt 4 Box 310A, Elkhorn WI 53121. 414/742-3179.\*

'72 Sonett III, complete engine rebuilt, new clutch, low mileage transmission, body good. Must sell, \$3,000 obo. Also, complete set '71 96 seats, tan leatherette, excellent condition, best offer. Judy Griffith, 1119 Stacy Lane, Macomb IL 61455. 309/837-2588.\*

## 93s, 95s and 96s For Sale

'73 96-V4, Verona Green, great shape, good runner, \$2,000. Partly restored '60 93 and '61 96 plus extra parts, motors, \$1,000. John P. Olin, 411 E 6th St, Chaska MN 55318. 612/476-1995 eves.\*

'71 96, 75% parted. Relocating, what you don't take must be scrapped. Haul it away, FREE. Busch Concarovs, 52 Alexander Rd, Colchester CT 06415. 203/537-4990 before 9pm EST.

'67 95 wagon, 2-stroke, NO rust, RF fender dented, 105k mi, everything works, \$3,000. Good '72 95-V4, stuck in 2nd, \$1,200. John P. Olin, 411 E 6th St, Chaska MN 55318. 612/448-6855 days.\*

**STROKERS!** Good interiors, solid bodies, standard 3-cyl. engines. I need the space!  
'66 Special, disc brakes, 4-bolt wheels, \$1,696.  
'67 96, great paint, late seats, \$2,696.  
'67 96, ugly, needs freewheel, \$696.  
Larry Williams, 3322 Rosehill, Waterloo IA 50701. 319/235-0275.

## 2-Stroke & V4

### Parts and Accessories

Sonett III parts: Front or rear fiberglass, \$200. Soccer ball mags, \$40 ea. Doors, \$30. Many more, call or write for list. SAAB Parts, PO Box 17796, San Diego CA 92177. 619/273-7042.

Sonett III parts: Wheels, engine and suspension parts, transmission, gas tank, '74 bumpers, glass, dash, controls, instruments, much more. Call or write for list. Michael Vest, 139 Escondido, Altamonte Springs FL 32701. 407/834-0923.

Parting out: '74 Sonett III, selling all parts large and small. Mark School, 313 E Greenfield St, Appleton WI 54911. 414/731-5289.\*

## 99s, 900s and 9000s For Sale

'87 9000S, 34k mi, auto trans, all the goodies. \$12,000. Tom Higgs, 1837 Gloucester Pl, Clinton MS 39056. 601/354-1686 7am-5pm.

'85 900 SPG, excellent cond, never hit, 92k mi. New Konis, sport exh, replaced turbo, Euro headlights, K&N. Oil changes/3k, service/15k. \$9,850 obo. Doug Smith, 32 Murphy Rd, Wilmington DE 19803. 302/652-0220.

'84 900S 4dr, 68k mi, Grey w/Burgundy velour, So Calif car, fresh AT. \$5,495 obo or trade for equally nice 5-spnd SAAB, not necessarily Turbo. Ken Edwards, Rt 3 Box 114, Jonesborough TN 37659. 615/753-3153.

'83 900 Turbo 3dr, 5spnd, Black, 125k mi. Shelby wheels, console w/VDO gauges, AC, AM/FM stereo tape, sheepskins, manuals, tools, well maintained. \$3,800 obo. Michael Vest, 139 Escondido, Altamonte Springs FL 32701. 407/834-0923.

'83 900S 3dr, Auto, 96k mi, Silver w/Lt Blue interior, AC, aluminum wheels, SR deflector. Delivery assistance. \$2,600 obo, will consider trade for Sonett. Michael Vest, 139 Escondido, Altamonte Springs FL 32701. 407/834-0923.

'76 99GL 4dr, Green, 145k mi, very good condition, 2 new tires, AC, hitch. Needs 4spnd rebuilt. \$300. W.F. Meiklejohn, 401 S 15th, Rocky Ford CO 81067. 719/254-6280.

'75 99LE Wagonback, 69k mi, Orange w/Dk Brown interior. Very good body, bad engine. \$300. John Machuta, 24419 Westmoreland, Farmington Hills MI 48336. 313/476-5258 after 6pm or leave message.

'75 99LE, 85k mi, White w/Brown vinyl top, Tan 900 interior, rebuilt AT, AM/FM, tinted windows, no rust. New headliner, P3s & battery. \$2,495 obo. Photos, \$5. Can deliver. Ken Edwards, Rt 3 Box 114, Jonesborough TN 37659. 615/753-3153.

'73 99EMS 2dr, 1st year, Yellow w/B&W side stripes, driven daily. Leather covered steering wheel, tach, soccerball mags, Tan interior, carbureted. \$2,495 obo, photos \$5. Can deliver. Ken Edwards, Rt 3 Box 114, Jonesborough TN 37659. 615/753-3153.



**99, 900 & 9000**

**Parts & Accessories**

99 & 900 OEM parts, wholesale prices to SAAB Club members. Aftermarket parts, engines, transmission, large assortment of used parts. New cylinder heads, 81+; new-style heater control valve; new-style outer CV joint. Call for price and availability. Installation and service available. Mastercard/Visa accepted. Trollhattan Motors Inc., 310 George Ave, Baltimore MD 21221. 301/682-4688 or 1-800-32-TROLL. Evening and Saturday hours.

99 & 900 Headliner Kit, comes with glue, 3 1/2 yards of material and complete instructions, \$87.50. Other parts available. Trollhattan Motors Inc., 310 George Ave, Baltimore MD 21221. 301/682-4688 or 1-800-32-TROLL. Evening and Saturday hours.

Your SAAB manual transmissions rebuilt from \$795. Includes replacement of bearings and seals, and set to factory specs. Why buy used and not be sure? Call for details. Freight additional. Mastercard and Visa accepted. Trollhattan Motors Inc., 310 George Ave, Baltimore MD 21221. 301/682-4688 or 1-800-32-TROLL. Evening and Saturday hours.

Parting out: twelve 99s and seventeen 900s, 1973 thru 1988. New OE sunroof deflectors, 9000 only, \$39.00. Quantity discounts. Rod Beckner, 604 E First St, Albany OR 97321. Tele/fax 503/928-6351.

2 Gislaved snows on rims w/hubs. Used 3 months only. Greg Citarella, #5 Old Rte 9, Wappinger Falls NY 12590. 914/297-7693.

Parting out: '79 thru '86 900s. 8-valve, 16-valve, Turbos, SPGs. Drivetrain, interior, body, suspension, wheels, rblt transmssions & more. Mike Caro, Wallingford CT. 203/284-8989.

Maroon sheepskins, factory accessory, \$75/pr. Elect antenna motor, needs shaft & cable, \$35. J. Swansey, PO Box 6117, Kingston NY 12401. 914/757-3201.

'79 900T parts: Complete 5-dr interior, seats in excellent condition, Rust Brown. 4 mag rims, \$100. Whale tail, \$100. Misc parts. Jim Iverson, Cedar Rapids IA. 319/364-2683 eves.

99 parts: two New Bilstein rear shocks, #B46-395, in original boxes, \$37 ea. One used front Bilstein shock, excellent, \$15. Additional misc parts, write or call. Sheldon Rabin, 10 Cambridge Rd, East Hanover NJ 07936. 201/887-9075.

Tan leather interior from '84 900 4dr. '80 900 turbo engine, AC system, front axles, grille, green 5-dr interior, bumpers. 99 trailer hitch. John Eaton, 2245 Carter Ave, St. Paul MN 55108. 612/646-3335.

**Wanted, All Models**

For '83 900 Turbo: trailer hitch, bolt-on, light duty. Sheepskin seat covers, natural or tan color. 84-86 side bumper extensions. LF turn signal lens. J. Swansey, PO Box 6117, Kingston NY 12401. 914/757-3201.

'88 or later SPG 3-spoke alloy wheels, will trade for my 9000 OE alloys, even up or +\$? Phillip Niemann, 7620 W 52nd St, Overland Park KS 66202. 913/262-5966 after 4pm.

SPG lower appearance group panels (not the dealer installed aerodynamic pkg) to fit '86 900T. Brent Christensen, 790 Southampton, Farmington UT 84025. 801/451-0834.

Two SPG wheels, must be straight. Frank. 1-800-999-1820.

Lug bolts for late-style Sonett III mag wheels. Rich Haslachner, 843 Acacia Dr, Burlingame CA 94010. 415/344-2921.

Rear seat cushion for '80 900T 5dr, blue cloth. 900 factory shop manuals, sick 5-speeds, repairable Turbo grilles, aluminum gear lever housing for '85 900 5spd. Jim Iverson, Cedar Rapids IA. 319/364-2683 eves.

Saab service manuals for '88 9000 Turbo 5spd. Jerry Supino, 1292 Karth Lake Cir, Arden Hills MN 55112. 612/636-4361.

I need someone able and willing to mechanically restore my 1959 93B. I will pay reasonable rates for quality workmanship. Amateurs need not apply. References required. John Bottger, PO Box 25133, Richmond VA 23260. 804/359-4840 w, 804/288-7697 h.



**C.I.A.**  
Capitol Import Autos  
9201 W. Brown Deer Road  
Milwaukee, WI 53224

## SAAB CLUB SPECIALS of the MONTH

**Gislaved Snow Tire & Rim Combo**  
size 185/65HR15 - 900 & 9000  
Mounted & balanced - Ready to go!  
**\$119.50 each**

**Thermoplastic floor mats**

9000	All Colors	\$85.00/set
900	All Colors	\$67.00/set

**Thule Ski Rack**  
900, 9000 - built in locks, holds 6 pairs  
**\$74.00**

**WE KNOW SAAB'S**

Prices subject to change without notice.  
Expires Month End.

**1-800-225-2528**  
**FAX 414-355-7831**









Open 8 am to 6 pm  
Monday thru Friday



## Int'l Meet in Luxembourg

About 140 people and 60+ SAABs were in attendance at the 1990 International SAAB Clubs Meet held this past September in Luxembourg. We convened at a local pizzeria for registration and lunch. We then had the opportunity to do some sightseeing around the local area before gathering at the Sheraton Aerogolf Hotel for dinner.

After dinner, Jacques Fisch, president of the Luxembourg SAAB Club, presented each family attending a small plaque in recognition of their attendance. My wife, Maureen, and I plus one other couple [see Ben Bundy's letter on page 3] were the only SAABers from the USA to attend.

On Sunday morning, buses were provided to take attendees from the Sheraton to downtown for a walking tour of the old part of Luxembourg city.

We thoroughly enjoyed our visit to Luxembourg and thought the Luxembourg Club put on a good event.

Hope to see you in Seattle next year.

Richard Hansen  
Vancouver, WA

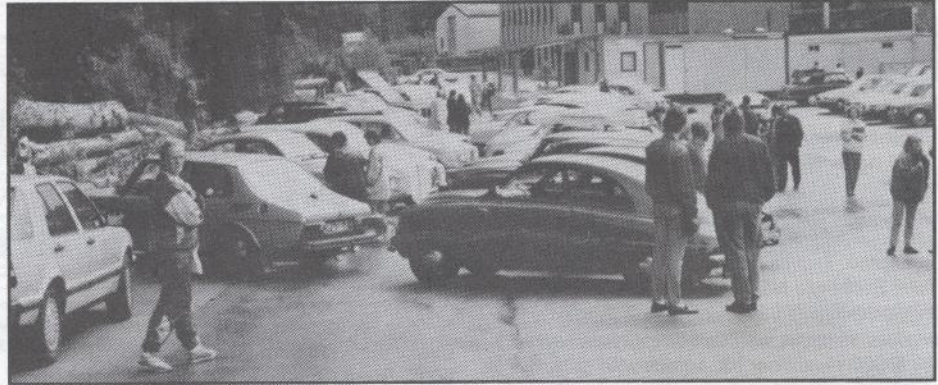

Above: Saabs from across northern Europe congregated in Luxembourg.



Right: A SAAB 92 that traveled 2,000 km from Norway.

photos by Richard Hansen.

## CHRISTMAS STOCKING STUFFERS!

### BOOKS



**SAAB ELECTRICS FOR EVERYONE**--Understand Saab wiring & more--  
\$40 ppd, USA, Canada  
\$44 ppd, Overseas

**SAAB STARTER, ALTERNATOR OVERHAUL MANUAL**--  
Covers 65-90 Saabs  
\$20 ppd, USA, Canada  
\$22 ppd, Overseas

**DREAMS & DEATAILS, 30 Years With Saabs**--A Great coffee table art book on Saabs!  
\$24 ppd, USA, Canada  
\$26 ppd, Overseas

**SAAB SOURCES**--Parts Interchange manual For 95, 96, Sonett--  
\$15 ppd, USA, Canada  
\$17 ppd, Overseas

### MAG WHEEL MOUNT STUDS

Makes changing wheels on Sonetts a snap. Triple chromed--\$12 +firt.

### FREE CATALOG

For the hard-to-get items for your Saab 95, 96 or Sonett. Over 40 items now available and more coming soon! FREE!

### GREAT GIFT IDEAS!

#### SWEATSHIRTS

Check out these new sweat shirts with new Saab art! Sizes tend to run small.

#### GIFT CERTIFICATES

When you can't figure out what to give. Call for details or send a check for the amount. We'll send the gift certificate pronto!



#### COMMUTER SURVIVAL PARTS KITS

Have the parts with you to fix 95% of the troubles that happen on the road to your 95, 96 or Sonett III! Don't go thru the woods to G'ma's house without one! Specify model--\$240 + firt.

CALL FOR DELIVERY BY XMAS!

**JACK ASHCRAFT  
AUTOMOTIVE DESIGN**  
2201 Woodlawn Drive, Medford, OR 97504  
503-779-0731



**THE 900 TURBO**

**NOW AVAILABLE!**  
2 NEW SWEATSHIRTS!  
Top quality. Great winter wear!  
Specify 900 or Sonett, Med, L or Ext L. Only \$19.95 Postpaid USA, Canada \$24 Postpaid Overseas





## MEMBERSHIP/SUBSCRIPTION

(Use also for Change of Address)

NAME \_\_\_\_\_

ADDRESS \_\_\_\_\_

CITY/STATE/ZIP \_\_\_\_\_

HOME PHONE \_\_\_\_\_ WORK PHONE \_\_\_\_\_

SAABS CURRENTLY OWNED \_\_\_\_\_

(i.e. '84 900 S 4dr. automatic / '78 99 GLE 5dr. 4-spd / '72 Sonett III / '68 96-V4 Deluxe)

Annual Membership fees for the SAAB Club of North America/NINES are as follows:

- First Year \$23.00  
 Renewal \$20.00

- Canadian add \$3.00U.S.  
 International add \$7.00U.S.  
Please check appropriate box(es)

(Canadian and International -- Money order or check payable on a U.S. bank only. Cash OK.)

First year members receive two recent back issues of NINES and two SAAB Club stickers.

MAKE CHECKS PAYABLE TO "THE SAAB CLUB"

- Address change only

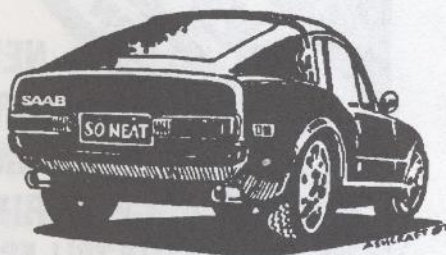

## Rear View

Celebrate! That word is almost abused at this time of year, but here at SAAB Club H.Q. there is plenty to celebrate as we enter 1991.

This is the fifth anniversary of my editorship. I look back at what the newsletter was five years ago, then contemplate what it can become in the next five.

When I became editor, membership had dropped to about 2,600. This month over 4,000 newsletters go out in our regular mailing, plus another 250 outside the U.S.

In 1986, the SAAB Club Newsletter was 12 pages, today it is 24, and may grow more in the next year. Contributions are up, advertising is up, and the enthusiasm of the SAAB Club members is keeping this newsletter strong.

You will note that this is issue number 198. February and March will be the double-sized newsletter I suggested last month, issue #200 (and #201)! The numbering system goes back to the days of the SAAB Owners Club of Chicago, predecessor to the SAAB Club of North America, and includes several single page flyers issued back in the early '70s.

March is also the 20th anniversary for the Saab Owners Club of Chicago. That group held its formative meeting in March, 1971. Dick Grossman took over as editor

for the Chicago club's newsletter, *Up Front*, in March, 1973, and added the title "Compact Front Wheel Drive Club of America" to the masthead in July, 1974. It was also about that time that Grossman began advertising the SAAB Club newsletter in *Road & Track* magazine, establishing it as the national independent publication about SAABs.

On top of all this celebration, there are expansion plans: A new computer has become a necessity to handle the latest, more complicated versions of Windows and PageMaker, and the old AT will be turned over to mailing list and bookkeeping chores (before the 5-year-old Commodore 128 goes Tango Uniform); some remodeling of office space so I'm not working out of boxes all the time, and maybe some staff additions so you can get better service.

We hope to be able to offer more merchandise in the next few months. Look for license plate frames (last month's ad was a bit premature; they'll be here in January), a new shirt design, and we hope to publish some books on older model SAABs.

All is not roses, however. As the newsletter grows, so does the work. The word "recession" is heard daily on the news. Our biggest expenses, printing and postage, are rising faster than inflation. The business side of the newsletter is a rather tight at the moment, despite a little more income from more subscriptions and advertising.

A price increase has become necessary to continue offering the quality of newsletter you have come to expect, and to make it even better. Printing costs have risen over 30 percent this year alone; postage is expected to take a 20 percent leap in a few months. Since this enterprise has always run with minimal profit, it can't absorb those increases. Our last price hike was nearly three years ago, coupled with the last rise in

postage.

Effective March 1st, renewal will be \$25.00, a new membership will be \$29.00. Canadian and overseas rates will rise as well, but the amount hasn't been established; it will depend on how much postage goes up. As with past increases, we'll allow you to renew for up to two years at the current rate prior to March 1.

Even at \$25.00, NINES is a bargain. It remains the lowest priced marque newsletter, and one of the most informative at any price. Don't look for color photos or glossy paper in this publication (unless the cost becomes competitive with black and white, and the paper can be recycled). Do look for a continuation of easily understood tech information for all SAAB cars. NINES is big on content, not flash.

With recession looming, more of you will be trying to do your own work to save a few dollars. NINES will continue to offer the technical help and parts sources you need, at a fraction of the hourly-rate at your local repair shop.

A happy holiday season to you from  
Tim & Vigen.

Tim Winker, editor

## NOTICE

Did you take video (or audio) tapes of tech sessions at the '90 National Convention? The SAAB Club would like copies of the tech sessions and performance panel discussion for our archives, or for possible inclusion in a book. Also seeking good originals of early SAAB factory shop manuals (model 93, 95/96/GT thru '64, 95/96-V4, Sonett II & V4). Contact Tim Winker, 218/724-1336.



# NINES

The SAAB Club Newsletter  
2416 London Road, Unit 900  
Duluth, MN 55812-2221

Exp: 90 12 RZ

FIRST CLASS

U.S. POSTAGE

PAID

PERMIT NO. 1909  
DULUTH, MINN.

Forwarding and  
Address Correction Requested

December 1990

FIRST CLASS MAIL

## Swedish Motors, Inc.

Essex & Decatur Streets  
Marietta, PA 17547  
717 - 426-2202



COMPUTERIZED INVENTORY OF  
NEW & USED SAAB & VOLVO PARTS

Best Prices on used engines, body,  
trans, interiors, glass & more

Oldest Nokia Tyre Dealer in U.S.

VISA/MC Accepted - UPS Shipping Daily

## SAAB ACCESSORIES

### SAAB PARKING ONLY

Parking sign \$24.95

### EURO STYLE HEADLIGHT COVERS

protects lights and gives your  
SAAB a clean, finished look \$49.50

DEAD PEDAL - fits all 900s & 9000s,  
provides a comfortable foot rest. \$24.00

FREE CATALOG AVAILABLE

(404) 587- 1356



8351 Roswell Rd, Suite 140  
Atlanta, GA 30350

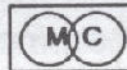

ROADSPORT

**SAAB**  
**CAMPBELL/NELSON**

**NEW  
FACTORY  
PARTS AND  
ACCESSORIES**

50 STATE TOLL FREE  
**1-800-552-2999**

Edmonds, WA (206) 778-1131  
Visa, M/Card, AMX  
RICH ROBERTS, SAAB PARTS MANAGER



# GOLDWING USED SAAB PARTS WAREHOUSE

Nationwide Shipping UPS - COD

- Alternators
- Starters
- Axles
- Calipers
- Antennas
- Radios
- Wheels
- Tires
- Tail Lights
- Window Motors
- Rack-n-Pinions

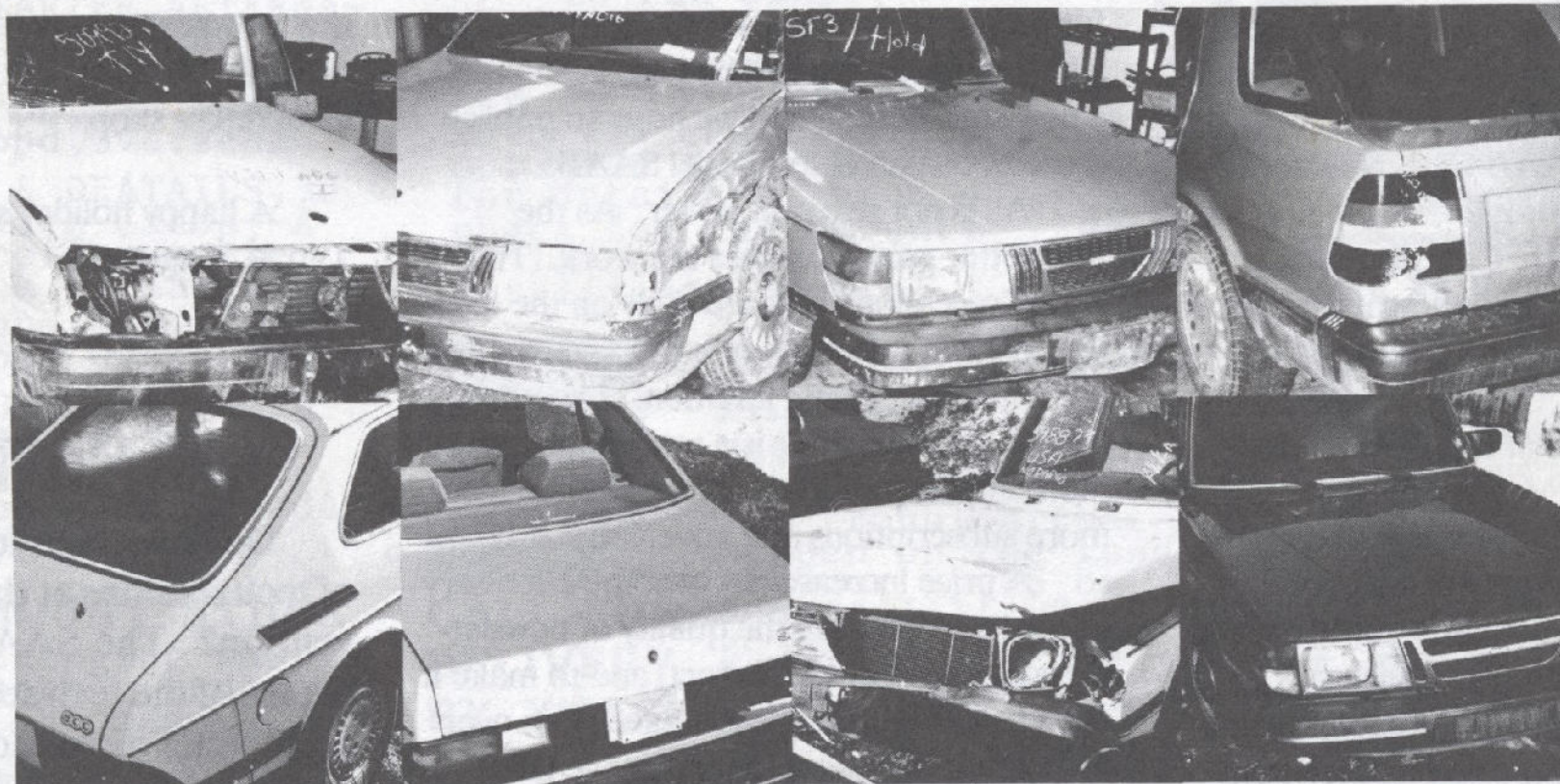

- Transmissions
- Engines
- Radiators
- Grills
- Fenders
- Turbos
- Bumpers
- Air Compressors
- Cyl. Hds.
- Seats

Call 1-800-SAAB137 or (315) 676-3311  
Rt. 11 Hastings, NY 13076